



X10DSC-TP4S

USER'S MANUAL

Revision 1.0a

The information in this user's manual has been carefully reviewed and is believed to be accurate. The vendor assumes no responsibility for any inaccuracies that may be contained in this document and makes no commitment to update or keep current the information in this manual nor to notify any person or organization of updates. **Please note: For the most up-to-date version of this manual, please see our website at www.supermicro.com.**

Super Micro Computer, Inc. ("Supermicro") reserves the right to make changes to the product described in this manual at any time and without notice. This product, including software and documentation, is the property of Supermicro and/or its licensors and is supplied only under a license. Any use or reproduction of this product is not allowed, except as expressly permitted by the terms of said license.

IN NO EVENT WILL SUPER MICRO COMPUTER, INC. BE LIABLE FOR DIRECT, INDIRECT, SPECIAL, INCIDENTAL, SPECULATIVE, OR CONSEQUENTIAL DAMAGES ARISING FROM THE USE OR INABILITY TO USE THIS PRODUCT OR DOCUMENTATION, EVEN IF ADVISED OF THE POSSIBILITY OF SUCH DAMAGES. IN PARTICULAR, SUPER MICRO COMPUTER, INC. SHALL NOT BE LIABLE FOR ANY HARDWARE, SOFTWARE, OR DATA STORED OR USED WITH THE PRODUCT, INCLUDING THE COSTS OF REPAIRING, REPLACING, INTEGRATING, INSTALLING, OR RECOVERING SUCH HARDWARE, SOFTWARE, OR DATA.

Any disputes arising between the manufacturer and the customer shall be governed by the laws of Santa Clara County in the State of California, USA. The State of California, County of Santa Clara shall be the exclusive venue for the resolution of any such disputes. Supermicro's total liability for all claims will not exceed the price paid for the hardware product.

FCC Statement: This equipment has been tested and found to comply with the limits for a Class A digital device pursuant to Part 15 of the FCC Rules. These limits are designed to provide reasonable protection against harmful interference when the equipment is operated in industrial environment. This equipment generates, uses, and can radiate radio frequency energy and, if not installed and used in accordance with the manufacturer's instruction manual, may cause harmful interference with radio communications. Operation of this equipment in a residential area is likely to cause harmful interference, in which case you will be required to correct the interference at your own expense.

California Best Management Practices Regulations for Perchlorate Materials: This Perchlorate warning applies only to products containing CR (Manganese Dioxide) Lithium coin cells. "Perchlorate Material-special handling may apply. See www.dtsc.ca.gov/hazardouswaste/perchlorate.



WARNING: This product can expose you to chemicals including lead, known to the State of California to cause cancer and birth defects or other reproductive harm. For more information, go to www.P65Warnings.ca.gov.

Manual Revision 1.0a

Release Date: January 31, 2020

Unless you request and receive written permission from Super Micro Computer, Inc., you may not copy any part of this document.

Information in this document is subject to change without notice. Other products and companies referred to herein are trademarks or registered trademarks of their respective companies or mark holders.

Copyright © 2020 by Super Micro Computer, Inc.
All rights reserved.

Printed in the United States of America

Preface

This manual is written for system integrators, PC technicians, and knowledgeable PC users. It provides information for the installation and use of the X10DSC-TP4S motherboard.

About This Motherboard

The Super X10DSC-TP4S motherboard supports dual Intel® E5-2600 v3/v4 Series processors (Socket R3) which offer the new Intel® microarchitecture 22nm (v3)/14nm (v4) processing technology with QuickPath Interconnect (QPI) speeds of up to 9.6 GT/s, delivering system performance and feature sets required for next-generation storage platforms. With the PCH C612 built in, the X10DSC-TP4S motherboard supports up to 512 GB of DDR4 2400 MHz DIMM memory, 90-bay 4U storage, three SAS expander capability, and 10G-SFP/LAN networking connectivity. This motherboard is ideal for near-line storage server platforms. Please refer to our website (<http://www.supermicro.com>) for CPU and memory support updates.

Manual Organization

Chapter 1 describes the features, specifications, and performance of the motherboard. It also provides detailed information about the Intel® PCH C612 chipset.

Chapter 2 provides hardware installation instructions. Read this chapter when installing the processor, memory modules, and other hardware components into the system. If you encounter any problems, see **Chapter 3**, which describes troubleshooting procedures for video, memory, and system setup stored in the CMOS.

Chapter 4 includes an introduction to BIOS and provides detailed information on running the BIOS Setup utility.

Appendix A defines the BIOS error beep codes.

Appendix B lists software installation instructions.

Appendix C contains UEFI BIOS recovery instructions.

Conventions Used in the Manual

Pay special attention to the following symbols for proper system installation:

Warning: Important information given to ensure proper system installation or to prevent damage to the components or injury to yourself;



Note: Additional information given to differentiate between models or instructions provided for proper system setup.

Contacting Supermicro

Headquarters

Address: Super Micro Computer, Inc.
980 Rock Ave.
San Jose, CA 95131 U.S.A.

Tel: +1 (408) 503-8000

Fax: +1 (408) 503-8008

Email: marketing@supermicro.com (General Information)
support@supermicro.com (Technical Support)

Website: www.supermicro.com

Europe

Address: Super Micro Computer B.V.
Het Sterrenbeeld 28, 5215 ML
's-Hertogenbosch, The Netherlands

Tel: +31 (0) 73-6400390

Fax: +31 (0) 73-6416525

Email: sales@supermicro.nl (General Information)
support@supermicro.nl (Technical Support)
rma@supermicro.nl (Customer Support)

Website: www.supermicro.nl

Asia-Pacific

Address: Super Micro Computer, Inc.
3F, No. 150, Jian 1st Rd.
Zhonghe Dist., New Taipei City 235
Taiwan (R.O.C)

Tel: +886-(2) 8226-3990

Fax: +886-(2) 8226-3992

Email: support@supermicro.com.tw

Website: www.supermicro.com.tw

Table of Contents

Preface

About This Motherboard.....	3
Manual Organization	3
Conventions Used in the Manual.....	4
Contacting Supermicro.....	5

Chapter 1 Overview

1-1 Overview	1-1
Checklist.....	1-1
X10DSC-TP4S Quick Reference	1-4
Motherboard Features.....	1-7
1-2 Processor and Chipset Overview.....	1-11
1-3 Special Features	1-12
Recovery from AC Power Loss.....	1-12
1-4 System Health Monitoring.....	1-12
Fan Status Monitor with Firmware Control	1-12
Environmental Temperature Control	1-12
System Resource Alert	1-12
1-5 ACPI Features.....	1-13
1-6 Power Supply.....	1-13
1-7 Advanced Power Management.....	1-14
Intel® Intelligent Power Node Manager (NM) (Available when the Supermicro Power Manager [SPM] is installed).....	1-14
Management Engine (ME).....	1-14

Chapter 2 Installation

2-1 Standardized Warning Statements	2-1
Battery Handling.....	2-1
Product Disposal	2-3
2-2 Static-Sensitive Devices.....	2-4
Precautions	2-4
Unpacking	2-4
2-3 Motherboard Installation.....	2-5
Tools Needed	2-5
Location of Mounting Holes	2-5
Installing the Motherboard	2-6
2-4 Processor and Heatsink Installation.....	2-7
Installing the LGA2011 Processor	2-7

	Installing a Passive CPU Heatsink	2-11
	Removing the CPU and the Heatsink	2-12
2-5	Installing and Removing the Memory Modules.....	2-13
	Installing & Removing DIMMs.....	2-13
	Removing Memory Modules	2-13
2-6	Control Panel Connectors and I/O Ports	2-16
	Back Panel Connectors and I/O Ports.....	2-16
	Back Panel I/O Port Locations and Definitions	2-16
	Serial/COM Ports	2-17
	Video Connection	2-17
	Universal Serial Bus (USB).....	2-18
	IPMI-Dedicated LAN Port.....	2-19
	SFP/LAN Port 1 - SFP/LAN Port 4	2-19
	Unit Identifier Switch/UID LED Indicators	2-20
	Front Panel Control Connector	2-21
2-7	Connecting Cables.....	2-22
	Power Connectors	2-22
	Power Distribution Board	2-22
	Internal Speaker	2-23
	Chassis Intrusion	2-23
	TPM/Port 80 Header	2-24
	SIOM Connector Header (Optional).....	2-24
	SAS AOM Connector Header.....	2-25
2-8	Jumper Settings	2-26
	Explanation of Jumpers	2-26
	Onboard LAN Enable	2-26
	VGA Enable.....	2-26
	CMOS Clear.....	2-27
	3008 SAS Controller Enable	2-27
	Manufacturer Mode Select	2-28
	BMC Enable	2-28
2-9	Onboard LED Indicators	2-29
	IPMI-Dedicated LAN LEDs.....	2-29
	SAS Heartbeat LEDs	2-29
	Onboard Power LED	2-30
	BMC Heartbeat LED	2-30
	SFP/LAN1 - SFP/LAN4 LED Indicators.....	2-31
2-10	SATA Connections.....	2-32
	I-SATA 0-3 Connections	2-32

Chapter 3 Troubleshooting

3-1	Troubleshooting Procedures	3-1
	Before Power On	3-1
	No Power	3-1
	No Video	3-2
	System Boot Failure	3-2
	Losing the System's Setup Configuration	3-2
	Memory Errors	3-3
	When the System Becomes Unstable	3-3
3-2	Technical Support Procedures	3-5
	Battery Installation	3-6
3-3	Battery Removal and Installation	3-6
	Battery Removal	3-6
	Proper Battery Disposal	3-6
3-4	Frequently Asked Questions	3-7
3-5	Returning Merchandise for Service	3-9

Chapter 4 BIOS

4-1	Introduction	4-1
	Starting BIOS Setup Utility	4-1
	How To Change the Configuration Data	4-1
	How to Start the Setup Utility	4-2
4-2	Main Setup	4-2
4-3	Advanced Setup Configurations	4-4
4-4	Event Logs	4-35
4-5	IPMI	4-37
4-6	Security Settings	4-39
4-7	Boot Settings	4-41
4-8	Save & Exit	4-43

Appendix A BIOS POST Error Beep Codes

A-1	BIOS POST Error Beep Codes	A-1
-----	----------------------------------	-----

Appendix B Software Installation Instructions

B-1	Installing Software Programs	B-1
B-2	Installing SuperDoctor5	B-2
B-3	Logging into the BMC (Baseboard Management Controller)	B-3

Appendix C UEFI BIOS Recovery Instructions

C-1	An Overview to the UEFI BIOS	C-1
C-2	How to Recover the UEFI BIOS Image (-the Main BIOS Block)	C-1
C-3	To Recover the Main BIOS Block Using a USB-Attached Device	C-1

Chapter 1

Overview

1-1 Overview

Checklist

Congratulations on purchasing your computer motherboard from an acknowledged leader in the industry. Supermicro motherboards are designed with the utmost care and attention to detail to provide you with the highest standards in quality and performance.

Please check that the following items have all been included with your motherboard. If anything listed here is damaged or missing, contact your retailer.

The X10DSC-TP4S motherboard was designed to be a part of an integrated server solution, and will not be sold as an independent, standalone product. Motherboard shipping package will not be included in your shipment.

 **Note 1:** For your system to work properly, please follow the links below to download all necessary drivers and utilities and the user's manual for your motherboard.

- Supermicro product manuals: <http://www.supermicro.com/support/manuals/>
- Product drivers and utilities: <ftp://ftp.supermicro.com/>

 **Note 2:** For safety considerations, please refer to the complete list of safety warnings posted on the Supermicro website at http://www.supermicro.com/about/policies/safety_information.cfm.

If you have any questions, please contact our support team at support@supermicro.com.

Motherboard Image

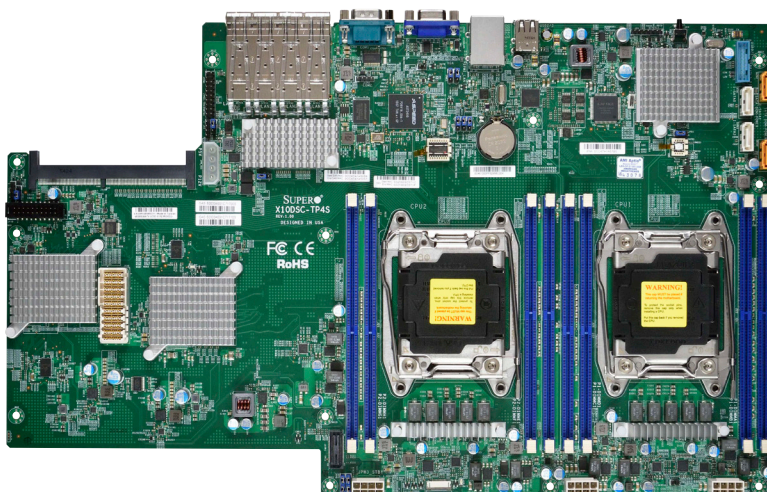

 **Note:** All graphics shown in this manual were based upon the latest PCB revision available at the time of publishing this manual. The motherboard you've received may or may not look exactly the same as the graphics shown in this manual.

Motherboard Layout

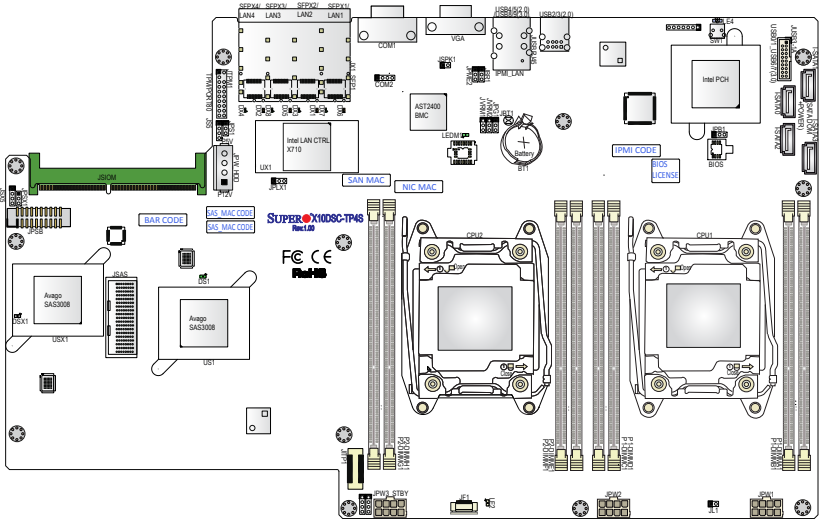

 **Note:** For the latest CPU/Memory updates, please refer to our website at <http://www.supermicro.com/products/motherboard/> for details.

X10DSC-TP4S Quick Reference

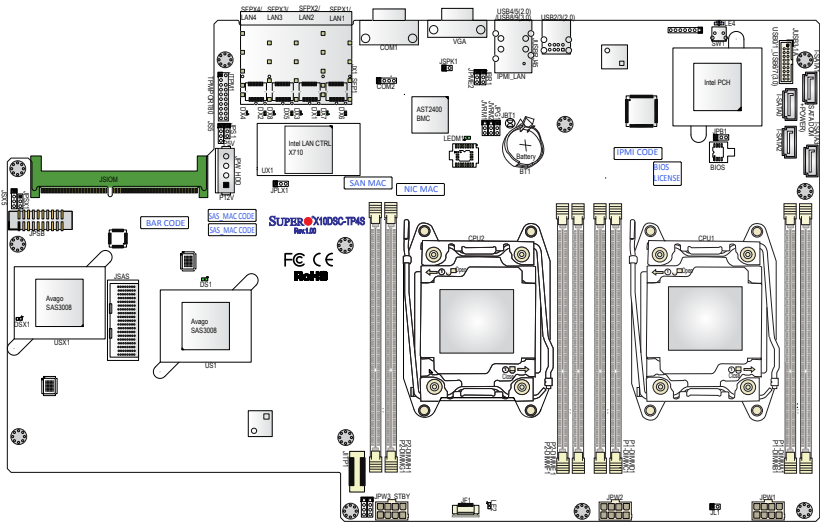

 **Notes:**

- See Chapter 2 for detailed information on jumpers, I/O ports, and JF1 front panel connections.
- "■" indicates the location of pin 1.
- Jumpers/LED indicators not indicated are used for testing only.
- Use only the correct type of onboard CMOS battery as specified by the manufacturer. Do not install the onboard battery upside down to avoid possible explosion.

X10DSC-TP4S Jumpers

Jumper	Description	Default Setting
JBT1	Clear CMOS/Reset BIOS Configuration	See Chapter 2
JPB1	BMC (Baseboard Management Controller) Enable	Pins 1-2 (Enabled)
JPG1	VGA Enable	Pins 1-2 (Enabled)
JPLX1	Onboard LAN Enable (for the X710 LAN controller located at UX1)	Pins 1-2 (Enabled)
JPME2	Manufacture (ME) Mode Select	Pins 1-2 (Normal)
JPS1	SAS Enable for the 3008 SAS controller located at US1	Pins 1-2 (Enabled)
JPSX1	SAS Enable for the 3008 SAS controller located at USX1	Pins 1-2 (Enabled)

X10DSC-TP4S Connectors

Connectors	Description
Battery (BT1)	Onboard CMOS battery (See Chpt. 3 for Used Battery Disposal)
COM1/COM2	Backplane COM port (COM1)/4-pin onboard serial port header (COM2)
JF1	Front Panel Control connector
JL1	Chassis intrusion header
JPSB	Power distribution board header (Part No: PDB-PT946-S386)
JPW1/2	12V 8-pin power connectors
JPW3_STBY	8-pin power connector for onboard 12V power and 12V standby power
JPW_HDD	4-pin (+5V/+12V) power connector for HDD use
JSAS	SAS 3008 add-on module connector used for SAS expanders (Part No: AOC-SAS3-946E90)
JSIOM	Supermicro I/O module connector (SIOM) for SIOM card use
JSPK1	Internal speaker/buzzer
JTPM1	TPM (Trusted Platform Module)/Port 80 header
IPMI_LAN	IPMI_dedicated LAN support by the ASpeed AST2400 controller
I-SATA 0-3	I-SATA 3.0 connections (0-3) supported by Intel PCH (I-SATA1 & I-SATA 3 support SMCI SuperDOM connections w/power pins built-in)
SFP/LAN1-SFP/LAN4 (JX1_SFP1)	10G SFP (small form-factor pluggable) Networking/LAN ports 1-4
SW1 (UID)	UID (Unit Identification) switch
(BP) USB 2/3 (2.0)	Backpanel USB 2.0 ports 2/3, 4/5 (USB1)
USB0/1 (2.0)/USB6/7 (3.0) (JUSB3-1A) (Optional)	USB 2.0 connections 0/1 or USB 3.0 connections 6/7 (optional)
USB4/5 (2.0)/USB8/9 (3.0) (JUSBRJ45)	Backpanel USB 2.0 ports 4/5 or USB 3.0 ports 8/9
VGA	Backpanel VGA port

X10DSC-TP4S Onboard LED Indicators

LED	Description	State	Status
DS1	SAS Heartbeat LED for SAS connections supported by the 3008 SAS controller located at US1	Green: Blinking	SAS Normal
DSX1	SAS Heartbeat LED for SAS connections supported by the SAS 3008 controller located at USX1	Green: Blinking	SAS Normal
DX1, 2, 5, 6	SFP/LAN1-SFP/LAN4 Link LEDs	Green: On	10Gb Link
DX3, 4, 7, 8	SFP/LAN1-SFP/LAN4 Activity LEDs	Green: Blinking	LAN Active
LE2	Onboard PWR LED	On	Power On
LE4	Rear UID LED	Blue: On	Unit Identified
LEDM1	BMC Heartbeat LED	Green: Blinking	BMC Normal

Motherboard Features

CPU	<ul style="list-style-type: none"> Dual Intel® E5-2600 v3/v4 Series processors (Socket R3-LGA 2011); each processor supports dual full-width Intel QuickPath Interconnect (QPI) links (of up to 9.6 GT/s one direction per QPI) 	
Memory	<ul style="list-style-type: none"> Integrated memory controller supports up to 1 TB of Registered (RDIMM) and Load Reduced (LRDIMM) DDR4 (288-pin) ECC 2400/2133/1866/1600/1333 modules in 16 slots <p> Note 1: Memory speed support depends on the processors used in the system.</p> <p>Note 2: For the latest CPU/memory updates, please refer to our website at http://www.supermicro.com/products/motherboard.</p>	
	DIMM Sizes	
	<ul style="list-style-type: none"> DIMM <p style="text-align: center;">Up to 64GB at 1.2V</p>	
Chipset	<ul style="list-style-type: none"> Intel® PCH C612 	
I/O Expansion	<ul style="list-style-type: none"> Supermicro proprietary I/O module connector for SIOM card use (optional) 	
Graphics	<ul style="list-style-type: none"> Graphics controller via ASpeed AST2400 BMC 	
	<ul style="list-style-type: none"> ASpeed AST2400 Baseboard Controller (BMC) supports IPMI 2.0 	
I/O Devices	SATA/SAS Connections	
	<ul style="list-style-type: none"> SATA 3.0 	<ul style="list-style-type: none"> Four (4) SATA 3.0 ports (2 SATA + 2 DOMs) supported by Intel PCH (S-SATA 0-3; I-SATA1/3 support SuperDOMs with power pins built-in)
	<ul style="list-style-type: none"> RAID (PCH) 	RAID 0, 1, 10

	<ul style="list-style-type: none"> SAS 3.0 	<ul style="list-style-type: none"> Two (2) onboard 3008 SAS controllers One (1) SAS add-on card header w/support of Supermicro proprietary SAS add-on card (AOC-SAS3-946E90), which is capable of supporting three (3) SAS expanders (JSAS)
	<ul style="list-style-type: none"> RAID 	Hardware RAID & Software RAID support
	IPMI 2.0	
	<ul style="list-style-type: none"> IPMI 2.0 supported by ASpeed AST2400 	
	Serial (COM) Port	
	<ul style="list-style-type: none"> One (1) Fast UART 16550 port on the I/O back panel One serial port header (COM2) 	
Peripheral Devices	USB Devices	
	<ul style="list-style-type: none"> Two (2) USB 3.0 ports on the rear I/O panel (USB 8/9), or two (2) USB 2.0 on the rear I/O panel (USB 4/5) Two (2) USB 2.0 ports on the rear I/O panel (USB 2/3) Two (2) USB 3.0 ports optional (USB 6/7), or two (2) USB 2.0 ports optional (USB 0/1) optional (JUSB3-1A) 	
BIOS	<ul style="list-style-type: none"> 16 MB SPI AMI BIOS® SM Flash UEFI BIOS 	
	<ul style="list-style-type: none"> ACPI 3.0/4.0, USB keyboard, Plug-and-Play (PnP), Riser card auto detection support, BIOS rescue hotkey, riser-card auto detect, Dual BootBlock support, PCI F/W 3.0, and SMBIOS 2.7 or later 	
Power Management	<ul style="list-style-type: none"> ACPI Power Management w/S1, S5 	
	<ul style="list-style-type: none"> Power-on mode for AC power recovery 	
	<ul style="list-style-type: none"> Main switch override mechanism 	
	<ul style="list-style-type: none"> Power-on mode for AC power recovery 	
	<ul style="list-style-type: none"> Intel® Intelligent Power Node Manager 3.0 (available when the Supermicro Power Manager [SPM] is installed and a special power supply is used. See the note on Page 1-14.) 	
	<ul style="list-style-type: none"> Management Engine (ME) 	

System Health Monitoring	System Health/CPU Monitoring
	<ul style="list-style-type: none"> Onboard voltage monitoring for 1.8V, +3.3V, 3.3V standby, +5V, +5V standby, +12V, CPU core, memory, chipset, BMC, PCH, and battery voltages
	<ul style="list-style-type: none"> CPU/system overheat LED and control
	<ul style="list-style-type: none"> CPU Thermal Trip support
	<ul style="list-style-type: none"> Status monitor for speed control
	<ul style="list-style-type: none"> CPU Thermal Design Power (TDP) support of up to 145W (See Note 1 below.)
	Fan Control
	<ul style="list-style-type: none"> Fan status monitoring via IPMI connections
	<ul style="list-style-type: none"> Single cooling zone
	<ul style="list-style-type: none"> Low-noise fan speed control
System Management	<ul style="list-style-type: none"> Pulse Width Modulation (PWM) fan control
	<ul style="list-style-type: none"> PECI (Platform Environment Control Interface) 2.0 support
	<ul style="list-style-type: none"> UID (Unit Identification)/Remote UID
	<ul style="list-style-type: none"> IPMIView, SMCIIIPMITOOL, IPMICFG
	<ul style="list-style-type: none"> Redundant power supply unit detection sensor
	<ul style="list-style-type: none"> System resource alert via SuperDoctor® 5
	<ul style="list-style-type: none"> SuperDoctor® 5
	<ul style="list-style-type: none"> Server platform service
Dimensions	<ul style="list-style-type: none"> Chassis intrusion header and detection
	<ul style="list-style-type: none"> RoHS
	<ul style="list-style-type: none"> 10.47" (L) x 16.97" (W) (265.94 mm x 431.04 mm)

 **Note 1:** The CPU maximum thermal design power (TDP) is subject to chassis and heatsink cooling restrictions. For proper thermal management, please check the chassis and heatsink specifications for proper CPU TDP sizing.

Note 2: For IPMI configuration instructions, please refer to the Embedded IPMI Configuration User's Guide available at <http://www.supermicro.com/support/manuals/>.

Note 3: It is strongly recommended that you change BMC log-in information upon initial system power-on. The manufacture default username is ADMIN and the password is ADMIN. For BMC setup, refer to http://www.supermicro.com/products/info/files/IPMI/Best_Practices_BMC_Security.pdf

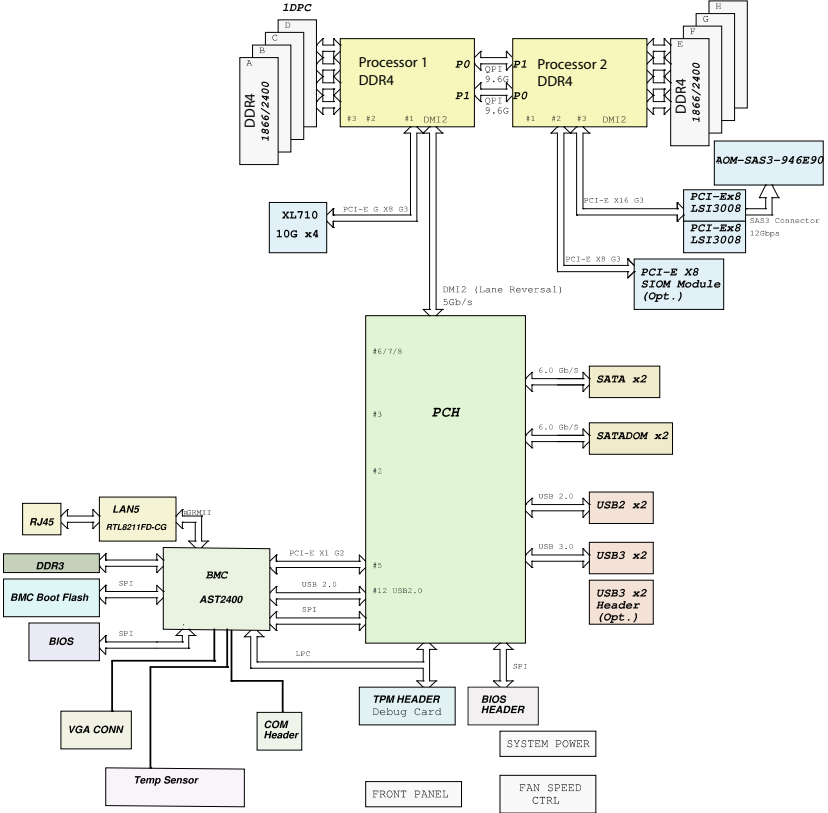

System Block Diagram

 **Note 1:** This is a general block diagram and may not exactly represent the features on your motherboard. See the Motherboard Features pages for the actual specifications of each motherboard.

Note 2: Both CPUs need to be installed for full access to the PCI-E slots, DIMM slots, and onboard controllers. Refer to the block diagram above to determine which slots or devices may be affected.

1-2 Processor and Chipset Overview

Built upon the functionality and capability of the Intel E5-2600 v3/v4 Series processors (Socket R3) and the Intel C612 PCH, the X10DSC-TP4S motherboard provides system performance, power efficiency, and feature sets to address the needs of next-generation computer users.

With support of the new Intel microarchitecture 22nm (v3)/14nm (v4) process technology, the X10DSC-TP4S drastically increases system performance for a multitude of server applications.

The PCH C612 chip provides Enterprise SMBus support, including the following features:

- DDR4 288-pin memory support on Socket R3
- Support for MCTP Protocol
- Support for Management Engine (ME)
- Improved I/O capabilities to high-storage-capacity configurations
- SPI enhancements
- Intel® Node Manager 3.0 for advanced power monitoring, capping, and management for BMC enhancement
- The BMC supports remote management, virtualization, and the security package for enterprise platforms



Note: Node Manager 3.0 support is dependent on the power supply used in the system.

1-3 Special Features

Recovery from AC Power Loss

The Basic I/O System (BIOS) provides a setting that determines how the system will respond when AC power is lost and then restored to the system. You can choose for the system to remain powered off (in which case you must press the power switch to turn it back on) or for it to automatically return to the power-on state. See the Advanced BIOS Setup section for this setting. The default setting is **Last State**.

1-4 System Health Monitoring

This section describes the features of system health monitoring of the motherboard. This motherboard has an onboard Baseboard Management Controller (BMC) that supports system health monitoring. An onboard voltage monitor will scan the following onboard voltages continuously: +1.8V, +3.3V, 3.3V standby, +5V, +5V standby, +12V, CPU core, memory, chipset, BMC, PCH, and battery voltages. Once a voltage becomes unstable, a warning is given or an error message is sent to the screen. The user can adjust the voltage thresholds to define the sensitivity of the voltage monitor.

Fan Status Monitor with Firmware Control

System health monitoring support provided by the BMC controller can check the RPM status of a cooling fan. The onboard CPU and chassis fans are controlled by IPMI Thermal Management.

Environmental Temperature Control

System health sensors in the BMC monitors temperatures and voltage settings of onboard processors and the system in real time via the IPMI interface. Whenever the temperature of the CPU or the system exceeds a user-defined threshold, system/CPU cooling fans will be turned on to prevent the CPU or system from overheating.

 **Note:** To avoid possible system overheating, please be sure to provide adequate airflow to your system.

System Resource Alert

This feature is available when used with SuperDoctor 5, which is used to monitor system hardware and notify the user of certain system events. For example, you can configure SuperDoctor 5 to warn you when the system temperature, CPU temperatures, voltages, or fan speeds go beyond a predefined range.

1-5 ACPI Features

ACPI stands for *Advanced Configuration and Power Interface*. The ACPI specification defines a flexible and abstract hardware interface that provides a standard way to integrate power management features throughout a system, including its hardware, operating system, and application software. This enables the system to automatically turn on and off peripherals such as network cards, hard-disk drives, and printers.

In addition to power management directed by the operating system, the ACPI also provides a generic system event mechanism for Plug-and-Play and interface (independent of the operating system) for configuration control. ACPI leverages the Plug-and-Play BIOS data structures, while providing implementation that is independent of the processor architecture and compatible with Windows 8/R2, Windows 2012/R2, and Windows 10 Operating Systems.

1-6 Power Supply

As with all computer products, a stable power source is necessary for proper and reliable operation. This is even more important for processors that have high CPU clock rates.

The X10DSC-TP4S motherboard accommodates two 8-pin 12V power connectors, one 8-pin 12V/12V Standby power connector, one 4-pin 12V_&_5V HDD power connector, and one power-distribution board. Although most power supplies generally meet the specifications required by the CPU, some are inadequate. Please connect all the power connectors to your power supply to ensure that adequate power is provided to your system.

It is strongly recommended that you use a high-quality power supply that meets the ATX power supply specification 2.02 or above. It must also be SSI-compliant. (For more information, please refer to the website at <http://www.ssiforum.org/>.) Additionally, in areas where noisy power transmission is present, you may choose to install a line filter to shield the computer from noise. It is recommended that you also install a power surge protector to help avoid problems caused by power surges.

1-7 Advanced Power Management

The following new advanced power management features are supported by this motherboard:

Intel® Intelligent Power Node Manager (NM) (Available when the Supermicro Power Manager [SPM] is installed)

The Intel® Intelligent Power Node Manager 3.0 (IPNM) provides your system with real-time thermal control and power management for maximum energy efficiency. Although IPNM Specification Version 2.0/3.0 is supported by the BMC (Baseboard Management Controller), your system must also have IPNM-compatible Management Engine (ME) firmware installed to use this feature.

 **Note:** Support for IPNM Specification Version 2.0 or Version 3.0 is dependent on the power supply used in the system.

Management Engine (ME)

The Management Engine, which is an ARC controller embedded in the PCH, provides Server Platform Services (SPS) to your system. The services provided by SPS are different from those provided by the ME on client platforms.

Chapter 2

Installation

2-1 Standardized Warning Statements

The following statements are industry-standard warnings, provided to warn the user of situations which might result in bodily injury. Should you have any questions or experience difficulty, contact Supermicro's Technical Support Department for assistance. Only certified technicians should attempt to install/change components or configure system settings.

Read this section in its entirety before installing/changing components or configuring system settings.

Battery Handling



Warning!

There is a danger of explosion if the battery is replaced incorrectly. Replace the battery only with the same or an equivalent type recommended by the manufacturer. Dispose of used batteries according to the manufacturer's instructions.

電池の取り扱い

電池交換が正しく行われなかった場合、破裂の危険性があります。交換する電池はメーカーが推奨する型、または同等のものを使用下さい。使用済電池は製造元の指示に従って処分して下さい。

警告

電池更換不當會有爆炸危險。請只使用同類電池或制造商推薦的功能相當的電池更換原有電池。請按製造商的說明處理廢舊電池。

警告

電池更換不當會有爆炸危險。請使用製造商建議之相同或功能相當的電池更換原有電池。請按照製造商的說明指示處理廢棄舊電池。

Warnung

Bei Einsetzen einer falschen Batterie besteht Explosionsgefahr. Ersetzen Sie die Batterie nur durch den gleichen oder vom Hersteller empfohlenen Batterietyp. Entsorgen Sie die benutzten Batterien nach den Anweisungen des Herstellers.

Attention

Danger d'explosion si la pile n'est pas remplacée correctement. Ne la remplacer que par une pile de type semblable ou équivalent, recommandée par le fabricant. Jeter les piles usagées conformément aux instructions du fabricant.

¡Advertencia!

Existe peligro de explosión si la batería se reemplaza de manera incorrecta. Reemplazar la batería exclusivamente con el mismo tipo o el equivalente recomendado por el fabricante. Desechar las baterías gastadas según las instrucciones del fabricante.

אזהרה!

קיימת סכנת פיצוץ של הסוללה במידה והוחלפה בדרך לא תקינה. יש להחליף את הסוללה בסוג התואם מחברת יצרן מומלצת.

סילוק הסוללות המשומשות יש לבצע לפי הוראות היצרן.

هناك خطر من التيار الكهربائي أو الطاقة الموجودة على اللوحة عندما يكون النظام يعمل كن حذرا عند خدمة هذا الجهاز

경고!

배터리가 올바르게 교체되지 않으면 폭발의 위험이 있습니다. 기존 배터리와 동일하거나 제조사에서 권장하는 동등한 종류의 배터리로만 교체해야 합니다. 제조사의 안내에 따라 사용된 배터리를 처리하여 주십시오.

Waarschuwing

Er is ontploffingsgevaar indien de batterij verkeerd vervangen wordt. Vervang de batterij slechts met hetzelfde of een equivalent type die door de fabrikant aanbevolen wordt. Gebruikte batterijen dienen overeenkomstig fabrieksvoorschriften afgevoerd te worden.

Product Disposal



Warning!

Ultimate disposal of this product should be handled according to all national laws and regulations.

製品の廃棄

この製品を廃棄処分する場合、国の関係する全ての法律・条例に従い処理する必要があります。

警告

本产品的废弃处理应根据所有国家的法律和规章进行。

警告

本產品的廢棄處理應根據所有國家的法律和規章進行。

Warnung

Die Entsorgung dieses Produkts sollte gemäß allen Bestimmungen und Gesetzen des Landes erfolgen.

¡Advertencia!

Al deshacerse por completo de este producto debe seguir todas las leyes y reglamentos nacionales.

Attention

La mise au rebut ou le recyclage de ce produit sont généralement soumis à des lois et/ou directives de respect de l'environnement. Renseignez-vous auprès de l'organisme compétent.

סילוק המוצר

אזהרה!
סילוק סופי של מוצר זה חייב להיות בהתאם להנחיות וחוקי המדינה.

عند التخلص النهائي من هذا المنتج ينبغي التعامل معه وفقا لجميع القوانين واللوائح الوطنية

경고!

이 제품은 해당 국가의 관련 법규 및 규정에 따라 폐기되어야 합니다.

Waarschuwing

De uiteindelijke verwijdering van dit product dient te geschieden in overeenstemming met alle nationale wetten en reglementen.

2-2 Static-Sensitive Devices

Electrostatic Discharge (ESD) can damage electronic components. To avoid damaging your motherboard, it is important to handle it very carefully. The following measures are generally sufficient to protect your equipment from ESD.

Precautions

- Use a grounded wrist strap designed to prevent static discharge.
- Touch a grounded metal object before removing the motherboard from the antistatic bag.
- Handle the motherboard by its edges only; do not touch its components, peripheral chips, memory modules, or gold contacts.
- When handling chips or modules, avoid touching their pins.
- Put the motherboard and peripherals back into their antistatic bags when not in use.
- For grounding purposes, make sure that your system chassis provides excellent conductivity between the power supply, case, mounting fasteners, and the motherboard.

Unpacking

The motherboard is shipped in antistatic packaging to avoid static damage. When unpacking the motherboard, make sure that the person handling it is static-protected.

2-3 Motherboard Installation

All motherboards have standard mounting holes to fit different types of chassis. Make sure that the locations of all mounting holes for both motherboard and chassis match. Although a chassis may have both plastic and metal mounting fasteners, metal ones are recommended because they ground the motherboard to the chassis. Make sure that the metal standoffs click in or are screwed in properly. Then use a screwdriver to secure the motherboard onto the motherboard tray.

Tools Needed

- Phillips screwdriver
- Panhead screws (12 pieces)
- Standoffs (12 pieces, if needed)

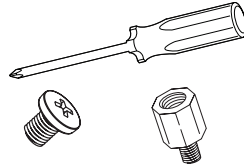

Location of Mounting Holes

There are twelve (12) mounting holes on this motherboard as indicated by the arrows.

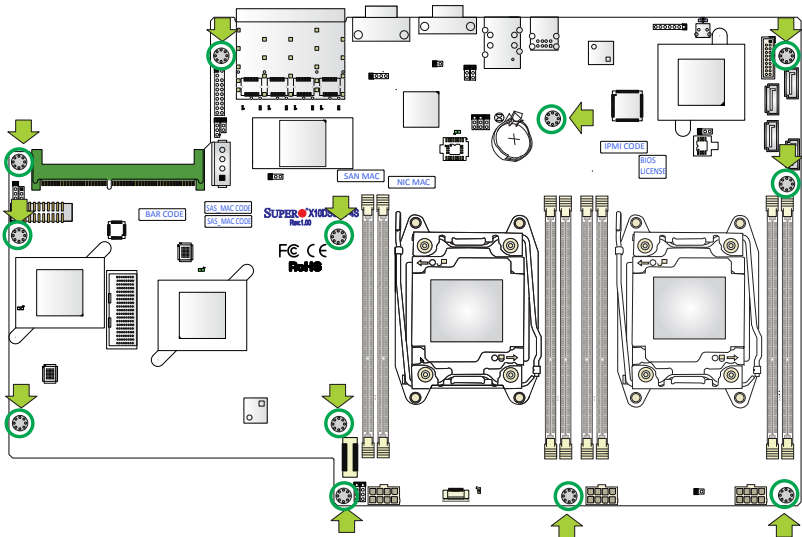

Caution: 1) To avoid damaging the motherboard and its components, do not use a force greater than 8 lb/inch on each mounting screw during motherboard installation. 2) Some components are very close to the mounting holes. Please use caution to prevent damage to these components when installing the motherboard to the chassis.

Installing the Motherboard

 **Note:** Always connect the power cord last, and always remove it before adding, removing, or changing any hardware components.

1. Install the I/O shield into the chassis.

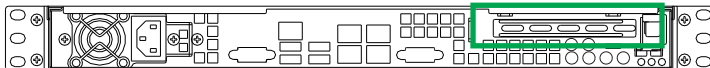

2. Locate the mounting holes on the motherboard.
3. Locate the matching mounting holes on the chassis. Align the mounting holes on the motherboard against the mounting holes on the chassis.
4. Install standoffs in the chassis if needed.

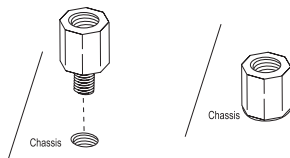

5. Install the motherboard into the chassis carefully to avoid damaging motherboard components.
6. Using the Phillips screwdriver, insert a panhead #6 screw into a mounting hole on the motherboard and its matching mounting hole on the chassis.

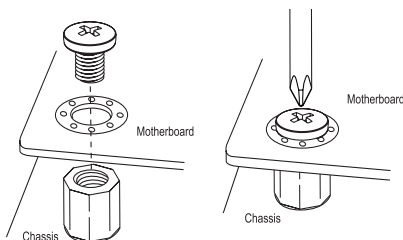

7. Repeat Step 5 to insert #6 screws into all mounting holes.
8. Make sure that the motherboard is securely placed in the chassis.

 **Note:** Images displayed are for illustration only. Your chassis or components might look different from those shown in this manual.

2-4 Processor and Heatsink Installation

Warning: When handling the processor package, avoid placing direct pressure on the label area. Also, improper CPU installation and socket/pin misalignment may cause serious damage to the CPU or the motherboard that will require RMA repairs. Be sure to read and follow all instructions thoroughly before installing your CPU and heatsink.

 **Notes:**

Always connect the power cord last, and always remove it before adding, removing, or changing any hardware components. Make sure that you install the processor into the CPU socket before you install the CPU heatsink.

If you buy a CPU separately, make sure that you use an Intel-certified multidirectional heatsink only.

Make sure to install the motherboard into the chassis before you install the CPU heatsink.

If you receive a motherboard without a processor pre-installed, make sure that the plastic CPU socket cap is in place and that none of the socket pins are bent; otherwise, contact your retailer immediately.

Refer to the Supermicro website for updates on CPU support.

Installing the LGA2011 Processor

1. There are two load levers on the LGA2011 socket. To open the socket cover, first press and release the load lever labeled "Open 1st."

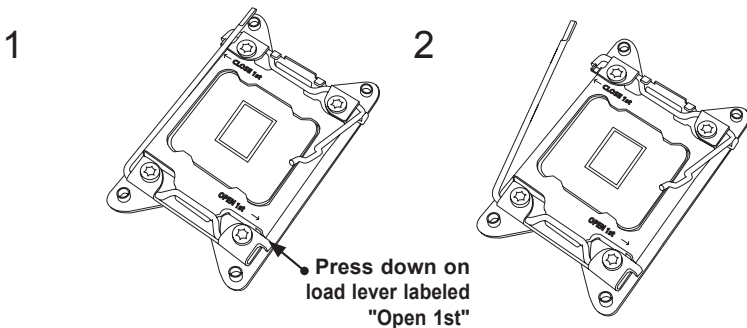

 **Note:** All graphics, drawings, and pictures shown in this manual are for illustration only. The components that came with your machine may or may not look exactly the same as those shown in this manual.

2. Press the second load lever labeled "Close 1st" to release the load plate that covers the CPU socket from its locking position.

1 **Press down on load lever "Close 1st"**

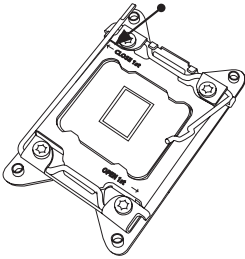

2 **Pull lever away from socket**

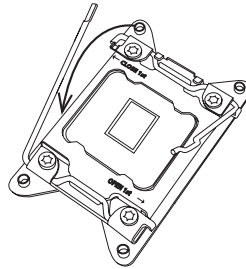

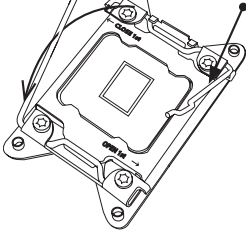

3. With the lever labeled "Close 1st" fully retracted, gently push down on the lever labeled "Open 1st" to open the load plate. Lift the load plate to open it completely.

1 **Gently push down to pop the load plate open**

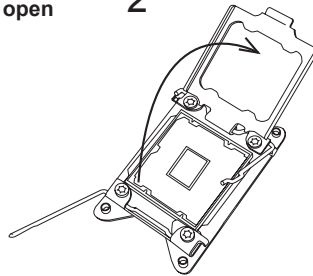

2



 **Note:** All graphics, drawings and pictures shown in this manual are for illustration only. The components that came with your machine may or may not look exactly the same as those shown in this manual.

- Use your thumb and index finger to loosen the lever and open the load plate.

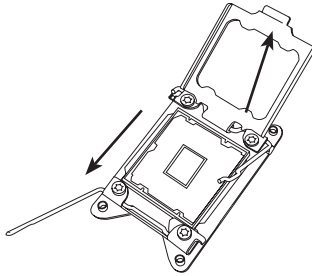

- Using your thumb and index finger, hold the CPU by its edges. Align the CPU keys, which are semicircle notches, against the socket keys.

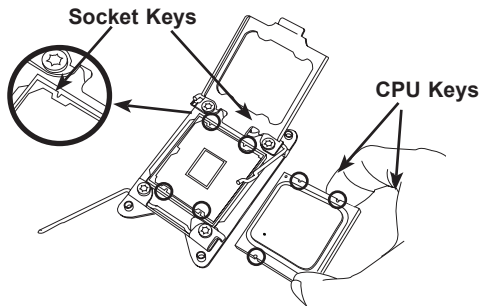

- Once they are aligned, carefully lower the CPU straight down into the socket. Do not drop the CPU on the socket or move the CPU horizontally or vertically. Do not rub the CPU against the surface or against any of the socket pins to avoid damaging the CPU or the socket.

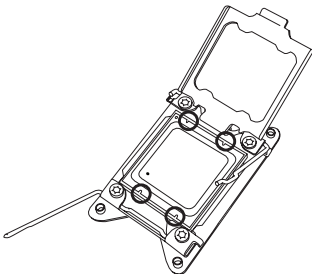

Warning: You can only install the CPU inside the socket in one direction. Make sure that it is properly inserted into the CPU socket before closing the load plate. If it doesn't close properly, do not force it as this may damage your CPU. Instead, open the load plate again to make sure that the CPU is aligned properly.

7. With the CPU inside the socket, inspect the four corners of the CPU to make sure that the CPU is properly installed.

1 Gently close the load plate

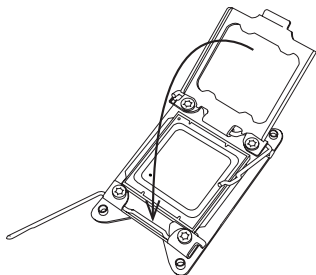

2 Push down and lock the lever labeled "Close 1st"

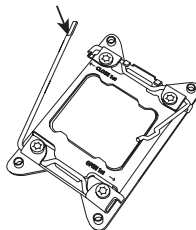

8. Close the load plate with the CPU inside the socket. Lock the lever labeled "Close 1st" first, then lock the lever labeled "Open 1st" second. Using your thumb, gently push the load levers down to the lever locks.

3

Lever Lock

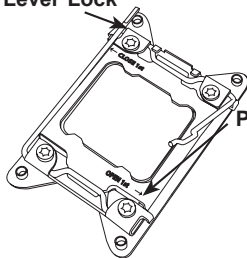

Push down and lock the lever labeled "Open 1st"

4

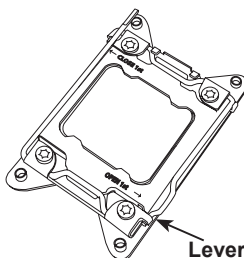

Lever Lock

Installing a Passive CPU Heatsink

1. Do not apply any thermal grease to the heatsink or the CPU die -- the required amount has already been applied.
2. Place the heatsink on top of the CPU so that the four mounting holes are aligned with those on the motherboard and the heatsink bracket underneath.
3. Screw in two diagonal screws (e.g., the #1 and the #2 screws) until just snug. Do not over-tighten the screws to avoid damaging the CPU and the motherboard.
4. Finish the installation by fully tightening all four screws.

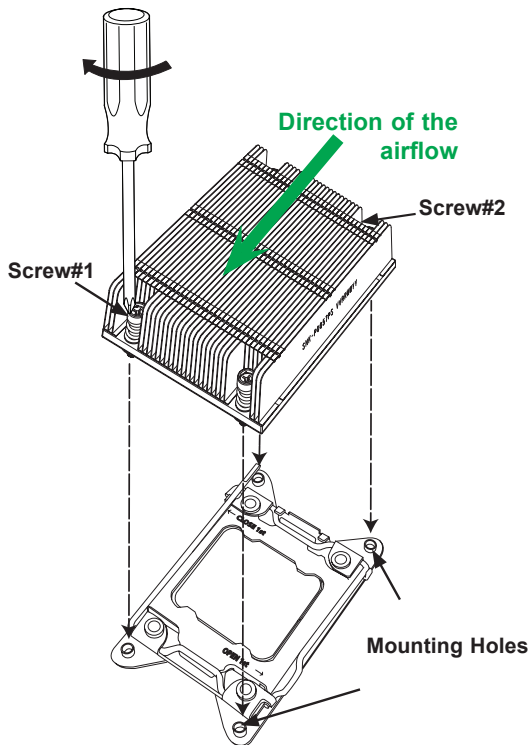



 **Note:** For optimal airflow, please follow the airflow direction of your chassis to correctly install the CPU heatsink. Graphic drawings included in this manual are for reference only. They might look different from the components installed in your system.

Removing the CPU and the Heatsink

Warning: We do not recommend that the CPU or the heatsink be removed. However, if you do need to uninstall the CPU or the heatsink, please follow the instructions below for heatsink/CPU removal to avoid damaging the CPU or the motherboard.

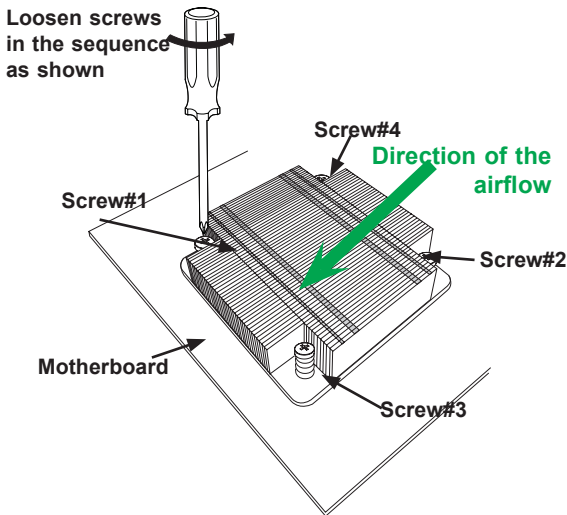
1. Unscrew the heatsink screws from the motherboard in the sequence as shown in the illustration below.
2. Gently wriggle the heatsink to loosen it from the CPU socket. Do not use excessive force when loosening the heatsink!
3. Once the heatsink is loosened, remove the heatsink from the socket. Once the heatsink is removed, remove the CPU from the socket as needed.
4. Remove the used thermal grease and clean the surface of the CPU and the heatsink. Reapply the proper amount of thermal grease on the surface before reinstalling the CPU and the heatsink as needed.



 **Notes:** 1.) For optimized airflow, please follow your chassis airflow direction to properly install the heatsink. 2.) Graphics shown in this manual are for reference only. They may or may not look the same as the components installed in your system.

2-5 Installing and Removing the Memory Modules

Note: Check Supermicro's website for a list of recommended memory modules.

CAUTION

Exercise extreme care when installing or removing DIMM modules to avoid damaging the DIMM modules or the motherboard.

Installing & Removing DIMMs

1. Insert the desired number of DIMMs into the memory slots, starting with P1-DIMMA1. For best performance, please use DIMM modules of the same type and speed in the same bank.
2. Push the release tabs outwards on both ends of the DIMM slot to unlock it.

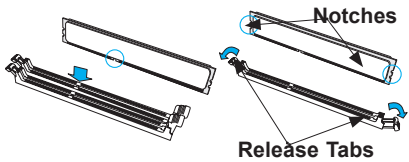
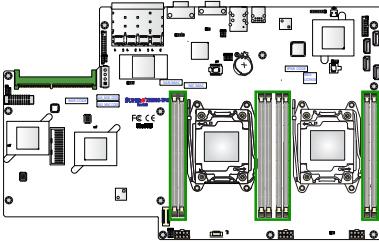

3. Align the key of the DIMM module with the receptive point on the memory slot.
4. Align the notches on both ends of the module against the receptive points at each side of the slot.
5. With your thumbs, press the notches on both ends of the module straight down into the slot until the module snaps into place.
6. Press the release tabs to their locking positions to secure the DIMM into the slot.

Press both notches straight down into the memory slot at the same time.

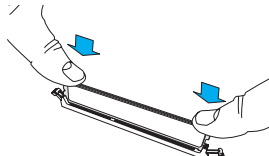

Removing Memory Modules

Press both release tabs on the ends of the DIMM to unlock it. Once the DIMM is loosened from the memory slot, remove it from the motherboard.

Memory Support for the X10DSC-TP4S Motherboard

The X10DSC-TP4S motherboard supports up to 512 GB of Registered (RDIMM), and Load Reduced (LRDIMM) DDR4 (288-pin) ECC 2400/2133/1866/1600/1333 MHz modules in 8 slots. Memory speed support depends on the CPUs installed in the motherboard. For the latest memory updates, please refer to our website at <http://www.supermicro.com/products/motherboard>.

Processor & Memory Module Population Configuration

For the memory to work properly, follow the tables below for memory installation.

Populating RDIMM/LRDIMM/NV-DIMM ECC Memory Modules

Processors and the Corresponding Memory Modules				
CPU#	Corresponding DIMM Modules			
CPU 1 P1-DIMM-	A1	B1	C1	D1
CPU2 P2-DIMM-	E1	F1	G1	H1

Processor and Memory Module Population for Optimal Performance	
Number of CPUs+DIMMs	CPU and Memory Population Configuration Table (For memory to work properly, please follow this table.)
1 CPU & 2 DIMMs	CPU1 P1-DIMMA1/P1-DIMMB1
1 CPU & 4 DIMMs	CPU1 P1-DIMMA1/P1-DIMMB1, P1-DIMMC1/P1-DIMMD1
2 CPUs & 4 DIMMs	CPU1 + CPU2 P1-DIMMA1/P1-DIMMB1, P2-DIMME1/P2-DIMMF1
2 CPUs & 6 DIMMs	CPU1 + CPU2 P1-DIMMA1/P1-DIMMB1/P1-DIMMC1/P1-DIMMD1, P2-DIMME1/P2-DIMMF1
2 CPUs & 8 DIMMs	CPU1 + CPU2 P1-DIMMA1/P1-DIMMB1/P1-DIMMC1/P1-DIMMD1, P2-DIMME1/P2-DIMMF1/P2-DIMMG1/P2-DIMMH1

Installing DDR4 Memory Modules

Populating RDIMM/LRDIMM DDR4 Memory Modules					
Type	Ranks Per DIMM and Data Width	DIMM Capacity (GB)		Speed (MT/s); Voltage (V); Slots per Channel (SPC) and DIMMs per Channel (DPC)	
				1 Slot per Channel	
				1 DPC	
				E5-2600 V3	E5-2600 V4
				1.2 V	1.2 V
RDIMM	SRx4	8 GB	16 GB	2133	2400
RDIMM	SRx8	4 GB	8 GB	2133	2400
RDIMM	DRx8	8 GB	16 GB	2133	2400
RDIMM	DRx4	16 GB	32 GB	2133	2400
LRDIMM	QRx4	32 GB	64 GB	2133	2400
LRDIMM 3DS	8Rx4	64 GB	128 GB	2133	2400

2-6 Control Panel Connectors and I/O Ports

The I/O ports are color-coded in conformance with the industry standards. See the picture below for the colors and locations of the various I/O ports.

Back Panel Connectors and I/O Ports

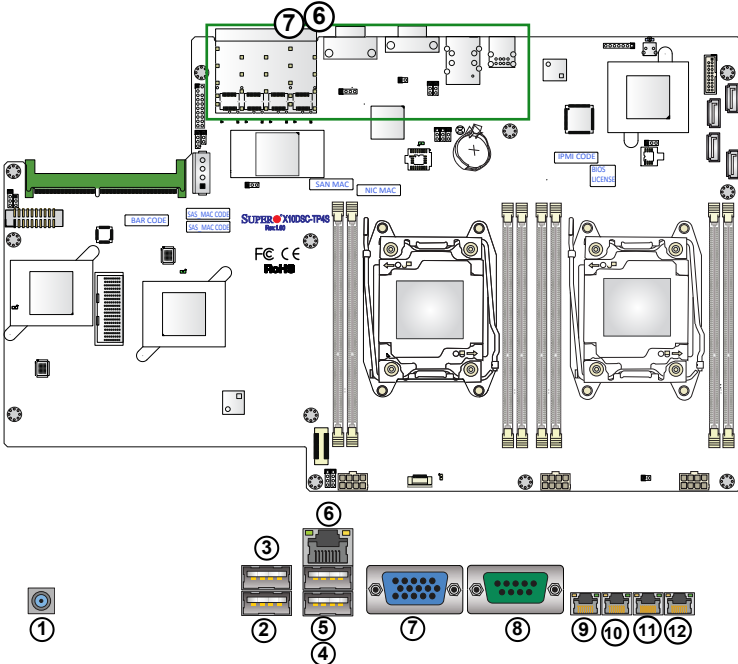

Back Panel I/O Port Locations and Definitions

1. UID (SW1)
2. USB 2 (USB 2.0)
3. USB 3 (USB 2.0)
4. USB 4 (USB 2.0) or USB 8 (USB 3.0)
5. USB 5 (USB 2.0) or USB 9 (USB 3.0)
6. IPMI_LAN
7. VGA
8. COM1
9. SFP+/LAN1
10. SFP+/LAN2
11. SFP+/LAN3
12. SFP+/LAN4

Serial/COM Ports

Two serial/COM connections are located on the motherboard. COM1 is located on the I/O backpanel, and COM2 header is located next to the Aspeed AST2400 BMC chip on the motherboard. Refer to the table below for COM2 pin definitions. Also, see the layout below for COM1 and COM2 locations.

COM Port 2 (COM2) Header Pin Definitions	
Pin#	Definition
1	RX
2	Ground
3	TX
4	Vref. 1.8V

Video Connection

A Video (VGA) port is located next to COM Port 1 on the I/O back panel. Refer to the board layout below for the location.



Universal Serial Bus (USB)

There are four USB ports located on the I/O backpanel. USB ports 2/3 support USB 2.0 connections. The other two USB ports located next to USB ports 2/3 can support both USB 2.0 or USB 3.0 connections. When used for USB 2.0 support, these two ports are labelled as USB 4/5 (USB 2.0). When used for USB 3.0 connections, these ports are labelled as USB 8/9 (USB 3.0). In addition, an onboard header, located next to the Intel PCH chip, also supports USB 2.0 or USB 3.0 connections. When this header is used for USB 2.0 support, it is labelled as USB 0/1 (USB 2.0). When used for 3.0 support, this header is labelled as USB 6/7 (USB 3.0) (Cables are not included.) See the tables on below for pin definitions.

Back Panel USB 2/3, 4/5 (2.0) Pin Definitions			
Pin#	Definition	Pin#	Definition
1	+5V	5	+5V
2	USB_PN1	6	USB_PN0
3	USB_PP1	7	USB_PP0
4	Ground	8	Ground

Onboard USB 0/1 (2.0) Pin Definitions			
Pin #	Definition	Pin #	Definition
1	+5V	2	+5V
3	USB_PN2	4	USB_PN3
5	USB_PP2	6	USB_PP3
7	Ground	8	Ground
9	Key	10	Ground

Back Panel USB 8/9 (3.0) Onboard USB 6/7 (3.0) Pin Definitions	
Pin#	Description
1	VBUS
2	SSRX-
3	SSRX+
4	Ground
5	SSTX-
6	SSTX+
7	GND_DRAIN
8	D-
9	D+

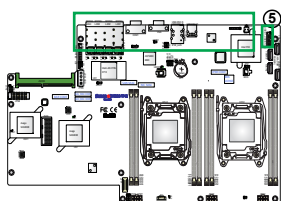

1. Back Panel USB2 (USB2.0)
2. Back Panel USB3 (USB2.0)
3. Back Panel USB4 (USB2.0)/USB8 (USB 3.0)
4. Back Panel USB5 (USB2.0)/USB9 (USB 3.0)
5. Onboard USB0/1 (USB2.0)/USB6/7 (USB 3.0)

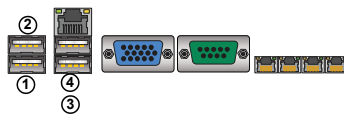

IPMI-Dedicated LAN Port

An IPMI-dedicated LAN, supported by the ASpeed AST2400 Baseboard Controller (BMC), is located above USB ports 4/5 on the I/O backpanel. Connect a RJ45 cable here for IPMI LAN support. Please refer to the LED Indicator section for LAN LED information.

SFP/LAN Port 1 - SFP/LAN Port 4

In addition to the IPMI_LAN, four SFP (Small Form-factor Pluggable) networking devices/LAN ports are also located on the I/O backplane. SFP/LAN port 1 - SFP/LAN port 4, supported by the Intel 710 controller, provide 10 gigabit LAN support for complex telecommunication and data communications applications. Appropriate cables are required for these connections. See the layout below for SFP/LAN1 - 4 locations.

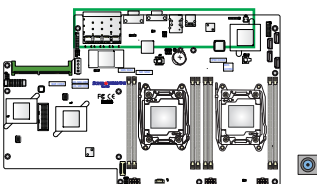

1. IPMI LAN
2. SFP/LAN1
3. SFP/LAN2
4. SFP/LAN3
5. SFP/LAN4

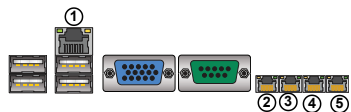

Unit Identifier Switch/UID LED Indicators

A rear Unit Identifier (UID) switch (SW1) and a rear UID LED (LE4) are located next to the Intel PCH chip on the motherboard. When you press the UID switch, the rear UID LED will be turned on. Press the UID switch again to turn off the LED indicator. The UID indicator provides easy identification of a system unit that may be in need of service.

 **Note:** UID can also be triggered via IPMI on the motherboard. For more information on IPMI, please refer to the IPMI user's guide posted on our website @ <http://www.supermicro.com>.

UID Switch	
Pin#	Definition
1	Ground
2	Ground
3	Button In
4	Ground

UID LED Status	
Color/State	Status
Blue: On	Unit Identified

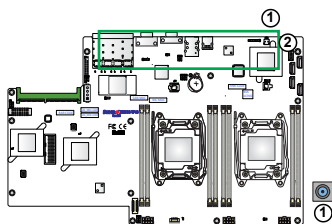

1. UID Switch
2. Rear UID LED



Front Panel Control Connector

A Supermicro proprietary front panel control connector is located at JF1. JF1 contains header pins and LED indicators that offer various functions for front panel access and system control. Please connect an appropriate cable to this header for user interface and system management. Refer to the layout below for the location of JF1.

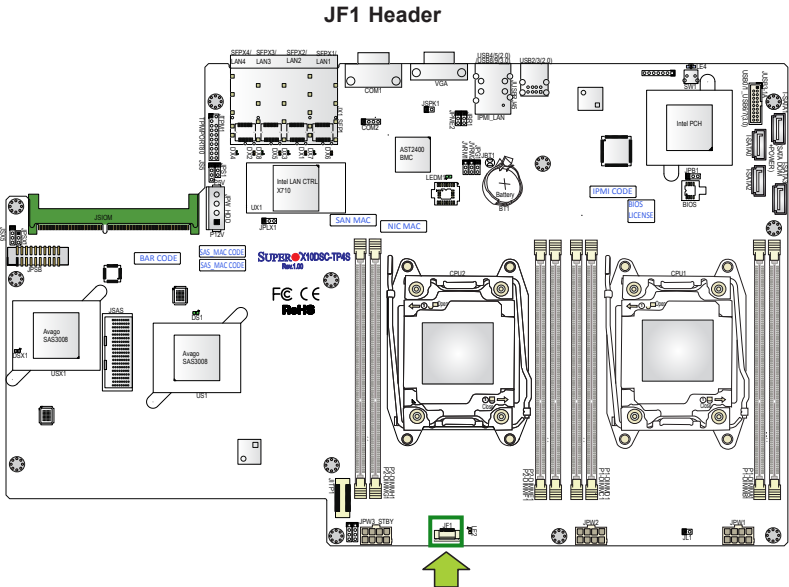

2-7 Connecting Cables

Power Connectors

Two 8-pin 12V power supply connectors (JPW1/JPW2) and an 8-pin 12V/12V standby power connector (JPW3-STBY) are located on the motherboard. In addition, a 4-pin power connector, located at JPW_HDD, provides 5V and 12V power to the onboard HDD devices. These power connectors meet the SSI EPS specifications and must be connected to your power supply to provide adequate power to the system. See the tables below for pin definitions.

8-pin 12V Power Connector (JPW1/2) Pin Definitions	
Pins	Definition
1 through 4	Ground
5 through 8	+12V

8-pin 12V/12V Standby Power Connector (JPW3_STBY) Pin Definitions	
Pins	Definition
Pins 1 - 4	Ground
Pin 5	12V Standby
Pins 6 - 8	+12V

4-pin 12V/5V Power Connector (JPW_HDD) Pin Definitions	
Pins	Definition
Pins 1	12V
Pin 2-3	Ground
Pins 4	5V

Power Distribution Board

A power distribution board header is located at JPSB on the motherboard. Install a Supermicro power distribution board (part number: PDB-PT946-S386) on this header to maximize power efficiency and enhance power management. See the layout below for the location.

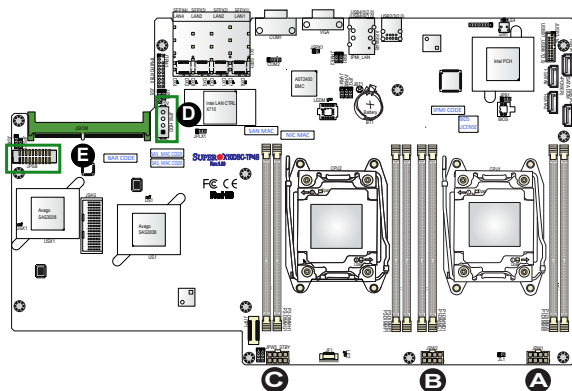

- A. JPW1: 8-Pin 12V PWR (required)
- B. JPW2: 8-Pin 12V PWR (required)
- C. JPW3: 8-Pin 12V/12V Standby (required)
- D. JPW_HDD: 4-Pin 12V/5V HDD PWR (required)

Internal Speaker

The Internal Speaker (JSPK1) can be used to provide audible notifications using various beep codes. See the table on the right for pin definitions. Refer to the layout below for the location of the internal buzzer.

Internal Buzzer Pin Definition		
Pin#	Definitions	
Pin 1	Pos. (+)	Beep In
Pin 2	Neg. (-)	Alarm Speaker

Chassis Intrusion

A Chassis Intrusion header is located at JL1 on the motherboard. Attach an appropriate cable from the chassis to inform you of a chassis intrusion when the chassis is opened.

Chassis Intrusion Pin Definitions	
Pin#	Definition
1	Intrusion Input
2	Ground

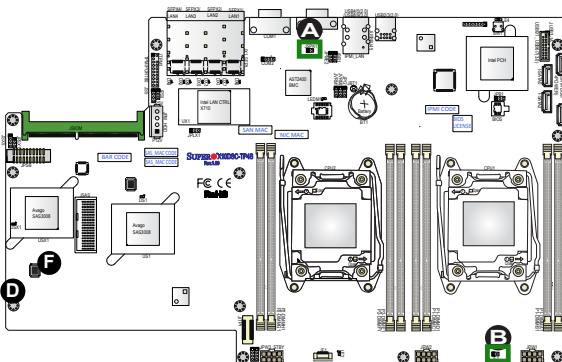

A. Internal Speaker

B. Chassis Intrusion

TPM/Port 80 Header

A Trusted Platform Module (TPM)/Port 80 header is located at JTPM1 on the motherboard to provide TPM support and a Port 80 connection. Use this header to enhance system performance and data security. See the table on the right for pin definitions.

TPM/Port 80 Header Pin Definitions			
Pin #	Definition	Pin #	Definition
1	LCLK	2	GND
3	LFRAME#	4	<(KEY)>
5	LRESET#	6	No Connection
7	LAD 3	8	LAD 2
9	+3.3V	10	LAD1
11	LAD0	12	GND
13	No Connection	14	No Connection
15	+3V STBY	16	SERIRQ
17	GND	18	CLKRUN#
19	LPCPD#	20	No Connection

SIOM Connector Header (Optional)

An optional Supermicro I/O Module (SIOM) connector header is located on the motherboard. Use this header to enhance system I/O expansion. See the layout below for the location.

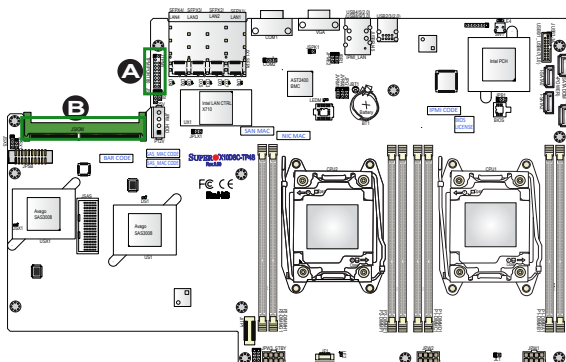

- A. TPM/Port 80
- B. SIOM (optional)

SAS AOM Connector Header

A 3008 Add-On Module (AOM) connector is located at JSAS on the motherboard. Install a Supermicro SAS Expander add-on card (Part Number: AOC-SAS3-946E90) on this header to use SAS expanders. When the AOC-SAS3-946E90 add-on card is installed, onboard 3008 SAS controllers will be enabled. The AOC-SAS3-946E90 supports up to three SAS expanders. See the layout below for the location.

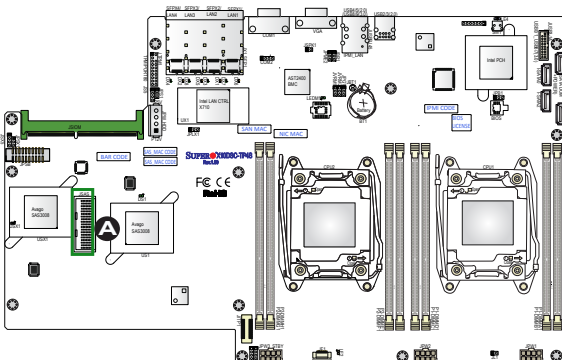

A. JSAS

2-8 Jumper Settings

Explanation of Jumpers

To modify the operation of the motherboard, jumpers can be used to choose between optional settings. Jumpers create shorts between two pins to change the function of the connector. Pin 1 is identified with a square solder pad on the printed circuit board. See the motherboard layout pages for jumper locations.

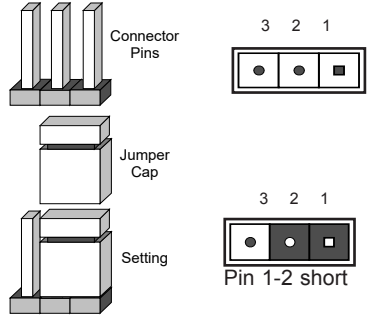

Note: On two-pin jumpers, "closed" means the jumper is on the pins, and "open" means the jumper is off them.

Onboard LAN Enable

Close pins 1 & 2 of Jumper JPLX1 to enable the onboard 710 LAN controller located at UX1. See the table on the right for jumper settings.

Onboard LAN Enable Jumper Settings	
Jumper Setting	Definition
1-2	Enabled (Default)
2-3	Disabled

VGA Enable

Jumper JPG1 allows the user to enable the onboard VGA connector. The default setting is 1-2 to enable the connection. See the table on the right for jumper settings.

VGA Enable Jumper Settings	
Jumper Setting	Definition
1-2	Enabled (Default)
2-3	Disabled

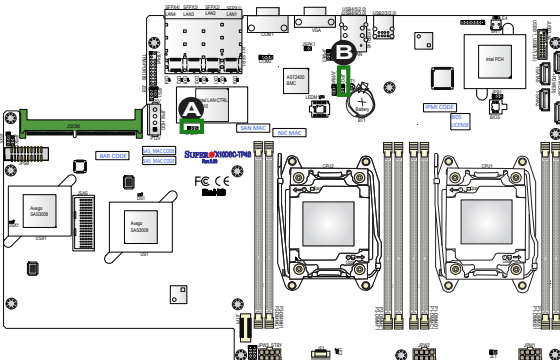

- A. Onboard LAN Enable
- B. VGA Enable

CMOS Clear

JBT1 is used to clear the CMOS. Instead of pins, this "jumper" consists of contact pads to prevent accidental clearing of the CMOS. To clear the CMOS, use a metal object such as a small screwdriver to touch both pads at the same time to short the connection.

 **Note:** Be sure to completely shut down the system, and then short JBT1 to clear the CMOS.

3008 SAS Controller Enable

Use Jumper JPS1 to enable or disable the 3008 SAS controller located at US1, and use Jumper JPSX1 for the SAS controller located at USX1. See the tables on the right for jumper settings.

SAS 3008 Controller Enable Jumper Assignments	
Jumper	Controller Supported
JPS1	for SAS Controller located at US1
JPSX1	for SAS Controller located at USX1

SAS 3008 Controller Enable Jumper Settings	
Jumper Setting	Definition
Pins 1-2	SAS Enable (Default)
Pins 2-3	SAS Disabled

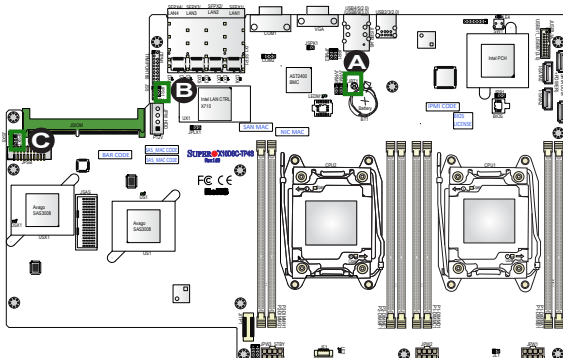

A. Clear CMOS

B. JPS1

C. JPSX1

Manufacturer Mode Select

Close pin 2 and pin 3 of Jumper JPME2 to bypass SPI flash security and force the system to operate in the manufacturer mode, which will allow the user to flash the system firmware from a host server for system setting modifications. See the table on the right for jumper settings.

ME Mode Select Jumper Settings	
Jumper Setting	Definition
1-2	Normal (Default)
2-3	Manufacture Mode

BMC Enable

Jumper JPB1 allows you to enable the embedded ASpeed AST2400 Baseboard Management Controller (BMC) to provide IPMI 2.0/KVM support on the motherboard. See the table on the right for jumper settings.

BMC Enable Jumper Settings	
Jumper Setting	Definition
Pins 1-2	BMC Enable (Default)
Pins 2-3	BMC Disabled

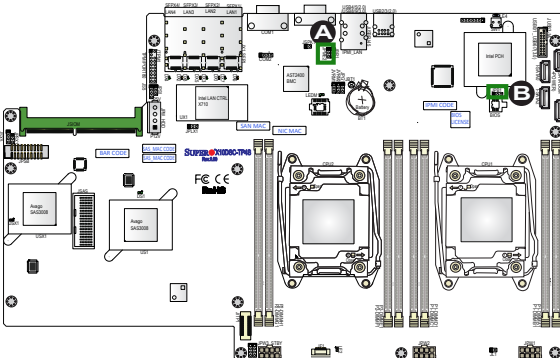

A. Manufacture Mode Select

B. BMC Enable

2-9 Onboard LED Indicators

IPMI-Dedicated LAN LEDs

An IPMI LAN is located on the I/O backpanel. The amber LED on the right indicates activity, while the green LED on the left indicates the speed of the connection. See the table at right for more information.



IPMI LAN Link LED (Left) & Activity LED (Right)		
	Color/State	Definition
Link (Left)	Green: Solid Amber: Solid	100 Mbps 1 Gbps
Activity (Right)	Amber: Blinking	Active

SAS Heartbeat LEDs

Two SAS Heartbeat LEDs are located on the motherboard. DS1 indicates the heartbeat status for the SAS connections supported by the SAS controller located at US1, while DSX1 is used to show the heartbeat state for the SAS connections supported by the SAS controller located at USX1. See the table at right for more information.

SAS Heartbeat LEDs LED States		
LED	Color/State	Definition
DS1	Green: Blinking	SAS connections supported by the SAS Controller at US1: Normal
DSX1	Green: Blinking	SAS connections supported by the SAS Controller at USX1: Normal

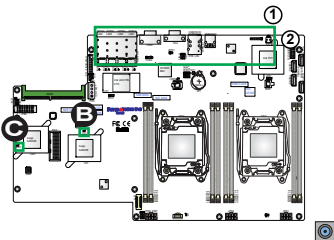

A. IPMI LAN LEDs

B. DS1

C. DSX1



Onboard Power LED

The Onboard Power LED is located at LE2 on the motherboard. When this LED is on, the system is on. Be sure to turn off the system and unplug the power cord before removing or installing components. See the tables at right for more information.

Onboard PWR LED Indicator LED States	
LED Color	Definition
Off	System Off (PWR cable not connected)
Green	System On

BMC Heartbeat LED

A BMC (Baseboard Management Controller) Heartbeat LED is located at LEDM1 on the motherboard. When LEDM1 is blinking, BMC functions normally. See the table at right for more information.

BMC Heartbeat LED States	
Color/State	Definition
Green: Blinking	BMC: Normal

 **Note:** Refer to Page 2-20 for information on the rear UID LED (LE4).

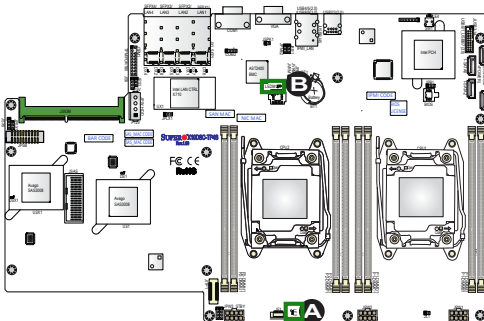

- A. PWR LED
- B. BMC Heartbeat LED

SFP/LAN1 - SFP/LAN4 LED Indicators

The Link LED indicators for SFP/LAN1-SFP/LAN4 indicators are located at DX1, DX2, DX5, DX6 on the motherboard. These Link LEDs indicate the speeds of SFP/LAN connections. The Activity LED indicators for SFP/LAN1-SFP/LAN4 indicators are located at DX3, DX4, DX7, DX8. See the tables on the right for more information.

SFP/LAN1-SFP/LAN4 Link LEDs Corresponding LED Status		
LED	Corresponding SFP/LAN Port	Link Speeds
DX1	SFP/LAN2	Green: 10Gbps, Amber: 1Gbps Off: No Connection, 10 or 100 Mbps
DX2	SFP/LAN4	Green: 10Gbps, Amber: 1Gbps Off: No Connection, 10 or 100 Mbps
DX5	SFP/LAN3	Green: 10Gbps, Amber: 1Gbps Off: No Connection, 10 or 100 Mbps
DX6	SFP/LAN1	Green: 10Gbps, Amber: 1Gbps Off: No Connection, 10 or 100 Mbps

SFP/LAN1-SFP/LAN4 Activity LEDs Corresponding LED Status		
LED	Corresponding SFP/LAN Port	Activity Status
DX3	SFP/LAN2	Green: Blinking: Active
DX4	SFP/LAN4	Green: Blinking: Active
DX7	SFP/LAN1	Green: Blinking: Active
DX8	SFP/LAN3	Green: Blinking: Active

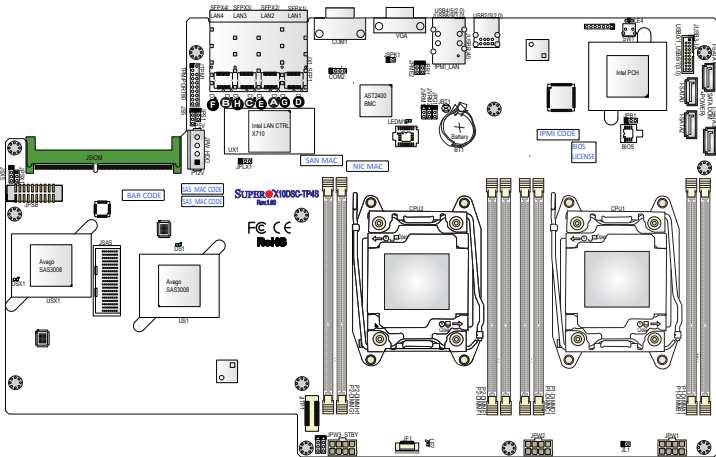

- A. DX1
- B. DX2
- C. DX5
- D. DX6
- E. DX3
- F. DX4
- G. DX7
- H. DX8

2-10 SATA Connections

I-SATA 0-3 Connections

Four I-SATA 3.0 connections are located on the motherboard. I-SATA (0-3) ports are supported by the Intel PCH chip. In addition, I-SATA 1/ I-SATA 3, colored in yellow, are used with Supermicro SuperDOM (Disk-on-Module) connectors with power-pins built in. The SuperDOM connectors are backward-compatible with regular SATA HDDs and SATA DOMs. All SATA ports provide serial-link signal connections, which are faster than the connections of Parallel ATA.

 **Note 1:** Supermicro SuperDOMs are yellow SATADOM connectors with power pins built in and do not require separate external power cables. These connectors are backward-compatible with non-Supermicro SATA-DOMs that require an external power supply.

Note 2: For more information on the SATA HostRAID configuration, please refer to the Intel SATA HostRAID user's guide posted on our website @ <http://www.supermicro.com>.

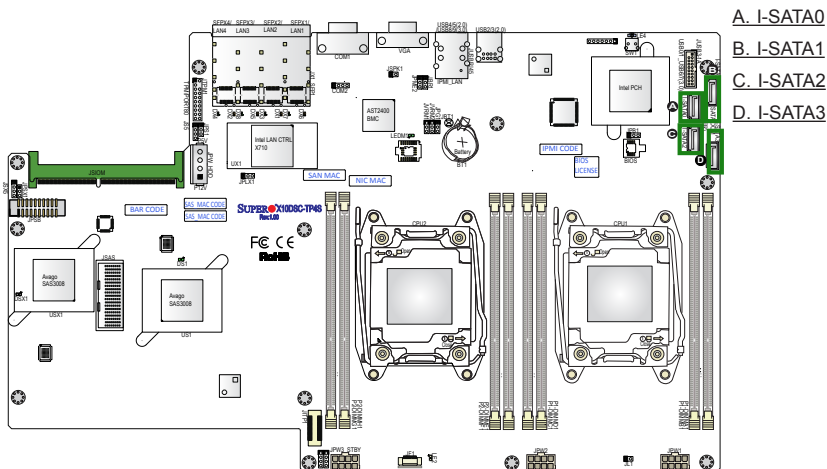

Chapter 3

Troubleshooting

3-1 Troubleshooting Procedures

Use the following procedures to troubleshoot your system. If you have followed all of the procedures below and still need assistance, refer to the "Technical Support Procedures" and/or "Returning Merchandise for Service" section(s) in this chapter.

Before Power On

1. Make sure that there are no short circuits between the motherboard and chassis.
2. Disconnect all ribbon/wire cables from the motherboard, including those for the keyboard and mouse.
3. Remove all add-on cards.
4. Install CPU 1 first (making sure it is fully seated) and connect the front panel connectors to the motherboard.

No Power

1. Make sure that there are no short circuits between the motherboard and the chassis.
2. Make sure that the ATX power connectors are properly connected.
3. Check that the 115V/230V switch, if available, on the power supply is properly set.
4. Turn the power switch on and off to test the system, if applicable.
5. The battery on your motherboard may be old. Check to verify that it still supplies ~3VDC. If it does not, replace it with a new one.

No Video

1. If the power is on but you have no video, remove all add-on cards and cables.
2. Use the speaker to determine if any beep codes are present. Refer to Appendix A for details on beep codes.

System Boot Failure

If the system does not display POST (Power On Self Test) or does not respond after the power is turned on, check the following:

1. Check for any error beep from the motherboard speaker.
 - If there is no error beep, try to turn on the system without DIMM modules installed. If there is still no error beep, try to turn on the system again with only one processor installed in CPU Socket 1. If there is still no error beep, replace the motherboard.
 - If there are error beeps, clear the CMOS settings by unplugging the power cord and contacting both pads on the CMOS Clear Jumper (JBT1). (Refer to the Jumper section in Chapter 2.)
2. Remove all components from the motherboard, especially the DIMM modules. Make sure that system power is on and that memory error beeps are activated.
3. Turn on the system with only one DIMM module installed. If the system boots, check for bad DIMM modules or slots by following the Memory Errors Troubleshooting procedure in this Chapter.

Losing the System's Setup Configuration

1. Make sure that you are using a high-quality power supply. A poor-quality power supply may cause the system to lose the CMOS setup information. Refer to the Connecting Cables section for details on recommended power supplies.
2. The battery on your motherboard may be old. Check to verify that it still supplies ~3VDC. If it does not, replace it with a new one.
3. If the above steps do not fix the setup configuration problem, contact your vendor for repairs.

Memory Errors

When a no-memory beep code is issued by the system, check the following:

1. Make sure that the memory modules are compatible with the system and that the DIMMs are properly and fully installed. (For memory compatibility, refer to the memory compatibility chart posted on our website @ <http://www.supermicro.com>.)
2. Check if different speeds of DIMMs have been installed. It is strongly recommended that you use the same RAM type and speed for all DIMMs in the system.
3. Make sure that you are using the correct type of Registered (RDIMM)/Load Reduction (LRDIMM) ECC DDR4 DIMM modules recommended by the manufacturer.
4. Check for bad DIMM modules or slots by swapping a single module among all memory slots and check the results.
5. Make sure that all memory modules are fully seated in their slots. Follow the instructions given in the memory support section in Chapter 2.
6. Please follow the instructions given in the DIMM population tables listed in the memory support section to install your memory modules.

When the System Becomes Unstable

A. If the system becomes unstable during or after OS installation, check the following:

1. CPU/BIOS support: Make sure that your CPU is supported and that you have the latest BIOS installed in your system.
2. Memory support: Make sure that the memory modules are supported by testing the modules using memtest86 or a similar utility.

 **Note:** Refer to the product page on our website @ <http://www.supermicro.com> for memory and CPU support and updates.
3. HDD support: Make sure that all hard disk drives (HDDs) work properly. Replace the bad HDDs with good ones.
4. System cooling: Check the system cooling to make sure that all heatsink fans and CPU/system fans, etc., work properly. Check the hardware monitoring

settings in the IPMI to make sure that the CPU and system temperatures are within the normal range. Also check the front panel Overheat LED and make sure that it is not on.

5. Adequate power supply: Make sure that the power supply provides adequate power to the system. Make sure that all power connectors are connected. Please refer to our website for more information on the minimum power requirements.
6. Proper software support: Make sure that the correct drivers are used.

B. If the system becomes unstable before or during OS installation, check the following:

1. Source of installation: Make sure that the devices used for installation are working properly, including boot devices such as CD/DVD.
2. Cable connection: Check to make sure that all cables are connected and working properly.
3. Using the minimum configuration for troubleshooting: Remove all unnecessary components (starting with add-on cards first), and use the minimum configuration (but with a CPU and a memory module installed) to identify the trouble areas. Refer to the steps listed in Section A above for proper troubleshooting procedures.
4. Identifying bad components by isolating them: If necessary, remove a component in question from the chassis, and test it in isolation to make sure that it works properly. Replace a bad component with a good one.
5. Check and change one component at a time instead of changing several items at the same time. This will help isolate and identify the problem.
6. To find out if a component is good, swap this component with a new one to see if the system will work properly. If so, then the old component is bad. You can also install the component in question in another system. If the new system works, the component is good and the old system has problems.

3-2 Technical Support Procedures

Before contacting Technical Support, please take the following steps. Also, please note that as a motherboard manufacturer, Supermicro also sells motherboards through its channels, so it is best to first check with your distributor or reseller for troubleshooting services. They should know of any possible problems with the specific system configuration that was sold to you.

1. Please go through the Troubleshooting Procedures and Frequently Asked Questions (FAQ) sections in this chapter or see the FAQs on our website (<http://www.supermicro.com/>) before contacting Technical Support.
2. BIOS upgrades can be downloaded from our website (<http://www.supermicro.com>).
3. If you still cannot resolve the problem, include the following information when contacting Supermicro for technical support:
 - Motherboard model and PCB revision number
 - BIOS release date/version (This can be seen on the initial display when your system first boots up.)
 - System configuration
4. An example of a Technical Support form is on our website at <http://www.supermicro.com/RmaForm/>.
 - Distributors: For immediate assistance, please have your account number ready when placing a call to our Technical Support department. We can be reached by email at support@supermicro.com.

3-3 Battery Removal and Installation

Battery Removal

To remove the onboard battery, follow the steps below:

1. Power off your system and unplug your power cable.
2. Locate the onboard battery as shown below.
3. Using a tool such as a pen or a small screwdriver, push the battery lock outwards to unlock it. Once unlocked, the battery will pop out from the holder.
4. Remove the battery.

Proper Battery Disposal

Warning! Please handle used batteries carefully. Do not damage the battery in any way; a damaged battery may release hazardous materials into the environment. Do not discard a used battery in the garbage or a public landfill. Please comply with the regulations set up by your local hazardous waste management agency to dispose of your used battery properly.

Battery Installation

To install an onboard battery, follow the steps below:

1. Power off your system and unplug your power cable.
2. Locate the onboard battery as shown below.
3. Identify the battery's polarity. The positive (+) side should be facing up.
4. Insert the battery into the battery holder and push it down until you hear a click to ensure the battery is securely locked.

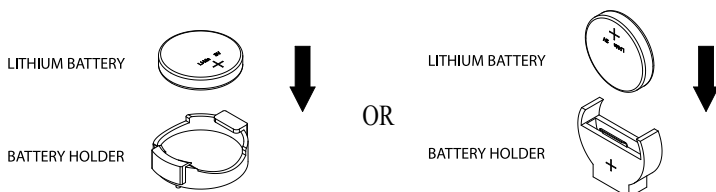

Note: When replacing a battery, be sure to only replace it with the same type.

3-4 Frequently Asked Questions

Question: What are the various types of memory that my motherboard can support?

Answer: The motherboard supports Registered (RDIMM)/Load Reduction (LRDIMM) ECC DDR4 DIMM modules. To enhance memory performance, do not mix memory modules of different speeds and sizes. Please follow all memory installation instructions given in the memory support section in Chapter 2.

Question: How do I update my BIOS under DOS?

It is recommended that you **do not** upgrade your BIOS if you are not experiencing any problems with your system. Updated BIOS files are located on our website at <http://www.supermicro.com>. Please check our BIOS warning message and the information on how to update your BIOS on our website. Select your motherboard model and download the BIOS file to your computer. Also, check the current BIOS revision to make sure that it is newer than your BIOS before downloading. You can choose from the zip file and the .exe file. If you choose the zip BIOS file, please unzip the BIOS file onto a bootable USB device. Run the batch file using the format FLASH.BAT filename.rom from your bootable USB device to flash the BIOS. Then, your system will automatically reboot.

Warning: Do not shut down or reset the system while updating the BIOS to prevent possible system boot failure!

 **Note:** The SPI BIOS chip used on this motherboard cannot be removed. Send your motherboard back to our RMA Department at Supermicro for repair. For BIOS Recovery instructions, please refer to the AMI BIOS Recovery Instructions posted at <http://www.supermicro.com>.

Question: How do I update my BIOS under UEFI Shell?

 **Note:** We do not recommend that you update your BIOS if you are not experiencing a BIOS-related problem. If you need to update your BIOS, please follow the steps below to properly update your BIOS under UEFI Shell.

1. Download and save the BIOS update package to your computer.
2. Extract the files from the UEFI folder of the BIOS package to a USB stick.

 **Note:** The USB stick doesn't have to be bootable; however, it has to be formatted with the FAT/FAT32 file system.

3. Insert the USB stick into a USB port, boot to the Build-In UEFI Shell, and type `FLASH.nsh BIOSname#.###` to start the BIOS update.

4. Enter the following commands:

```
Shell> fs0:
```

```
fs0:\> cd UEFI
```

```
fs0:\UEFI> flash.nsh BIOSname#.###
```

5. The FLASH.NSH script will compare the Flash Descriptor Table (FDT) code in the new BIOS with the existing one in the motherboard:

a. If a different FDT is found

- A new file, `STARTUP.NSH`, will be created, and the system will automatically reboot in 10 seconds without you pressing any key. BIOS will be updated after the system reboots.
- You can also press `<Y>` to force an immediate system reboot to shorten the process. During system reboot, press the `<F11>` key to invoke the boot menu and boot into the build-in UEFI Shell. Your BIOS will be updated automatically.

b. If the FDT is the same

- BIOS update will be immediately performed without a system reboot initiated.

Warning: Do not shut down or reset the system while updating the BIOS to prevent possible boot failure!

6. Perform an A/C power cycle after the message indicating the BIOS update has completed.

7. Go to the BIOS setup utility, and restore the BIOS settings.

Question: How do I handle the used battery?

Answer: Please handle used batteries carefully. Do not damage the battery in any way; a damaged battery may release hazardous materials into the environment. Do not discard a used battery in the garbage or a public landfill. Please comply with the regulations set up by your local hazardous waste management agency to dispose of your used battery properly.

3-5 Returning Merchandise for Service

A receipt or copy of your invoice marked with the date of purchase is required before any warranty service will be rendered. You can obtain service by calling your vendor for a Returned Merchandise Authorization (RMA) number. When returning the motherboard to the manufacturer, the RMA number should be prominently displayed on the outside of the shipping carton, and the shipping package is mailed prepaid or hand-carried. Shipping and handling charges will be applied for all orders that must be mailed when service is complete. For faster service, You can also request a RMA authorization online (<http://www.supermicro.com/RmaForm/>).

This warranty only covers normal consumer use and does not cover damages incurred in shipping or from failure due to the alternation, misuse, abuse or improper maintenance of products.

During the warranty period, contact your distributor first for any product problems.

Chapter 4

BIOS

4-1 Introduction

This chapter describes the AMI BIOS setup utility for the X10DSC-TP4S. The BIOS is stored in a Flash EEPROM and can be easily updated. This chapter describes the basic navigation of the AMI BIOS setup utility.

 **Note:** For AMI BIOS recovery, please refer to the UEFI BIOS Recovery Instructions in Appendix C.

Starting BIOS Setup Utility

To enter the AMI BIOS setup utility, press the <Delete> key while the system is booting up.

 **Note:** In most cases, the <Delete> key is used to invoke the AMI BIOS setup utility.

Each main BIOS menu option is described in this manual. The AMI BIOS setup menu screen has two main frames. The left frame displays all the options that can be configured. Grayed-out options cannot be configured. Options in blue can be configured by the user. The right frame displays the key legend. Above the key legend is an area reserved for a text message. When an option is selected in the left frame, it is highlighted in white. Often a text message will accompany it.

 **Note:** the AMI BIOS has default text messages built in. Supermicro retains the option to include, omit, or change any of these text messages.

The AMI BIOS setup utility uses a key-based navigation system called "hot keys." Most of the AMI BIOS setup utility "hot keys" can be used at any time during the setup navigation process. These keys include <F1>, <F4>, <Enter>, <Esc>, arrow keys, etc.

 **Note:** Options printed in **Bold** are default settings.

How To Change the Configuration Data

The configuration data that determines the system parameters may be changed by entering the AMI BIOS setup utility. This setup utility can be accessed by pressing at the appropriate time during system boot.

How to Start the Setup Utility

Normally, the only visible Power-On Self-Test (POST) routine is the memory test. As the memory is being tested, press the <Delete> key to enter the main menu of the AMI BIOS setup utility. From the main menu, you can access the other setup screens. An AMI BIOS identification string is displayed at the left bottom corner of the screen below the copyright message.

Warning: Do not upgrade the BIOS unless your system has a BIOS-related issue. Flashing the wrong BIOS can cause irreparable damage to the system. In no event shall Supermicro be liable for direct, indirect, special, incidental, or consequential damages arising from a BIOS update. If you have to update the BIOS, do not shut down or reset the system while the BIOS is updating to avoid possible boot failure.

4-2 Main Setup

When you first enter the AMI BIOS setup utility, you will enter the Main setup screen. You can always return to the Main setup screen by selecting the Main tab on the top of the screen. The Main BIOS setup screen is shown below.

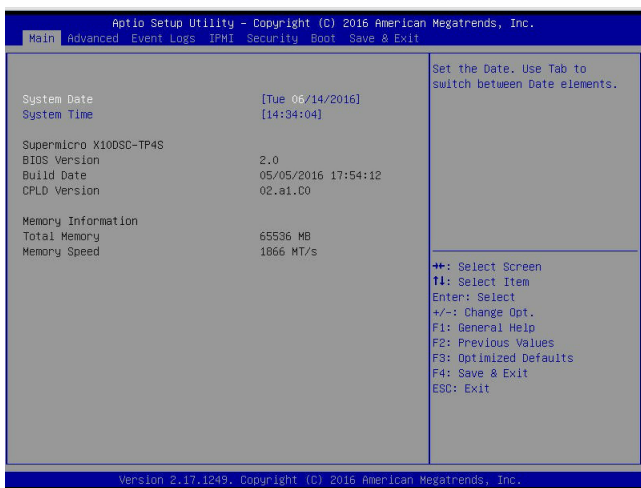

The following Main menu items will be displayed:

System Date/System Time

Use this option to change the system date and time. Highlight *System Date* or *System Time* using the arrow keys. Enter new values using the keyboard. Press the <Tab> key or the arrow keys to move between fields. The date must be entered in MM/DD/YYYY format. The time is entered in HH:MM:SS format.



Note: The time is in the 24-hour format. For example, 5:30 P.M. appears as 17:30:00.

Supermicro X10DSC-TP4S

BIOS Version: This item displays the version of the BIOS ROM used in the system.

Build Date: This item displays the date when the version of the BIOS ROM used in the system was built.

CPLD (Complex Programmable Logic Device) Version: This item displays the CPLD version used in the system.

Memory Information

Total Memory: This item displays the total size of memory available in the system.

Memory Speed: This item displays the default speed of the memory modules installed in the system.

4-3 Advanced Setup Configurations

Use the arrow keys to select Advanced setup and press <Enter> to access the submenu items:

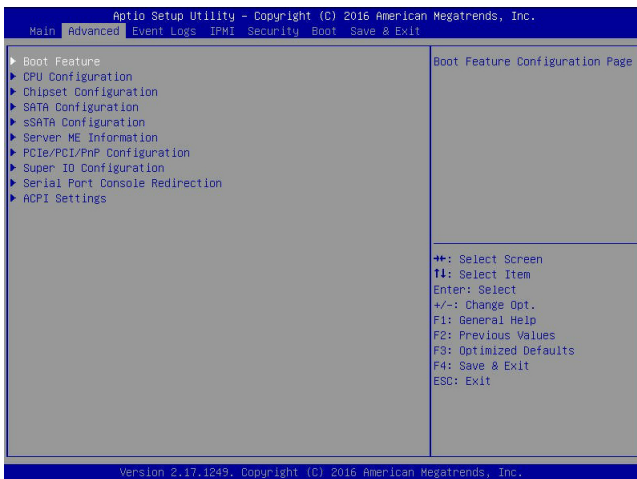

Warning: Take Caution when changing the Advanced settings. An incorrect value, a very high DRAM frequency or an incorrect BIOS timing setting may cause the system to malfunction. When this occurs, restore the setting to the manufacture default setting.

► Boot Feature

Quiet Boot

Use this item to select the screen display between POST messages or the OEM logo at bootup. Select Disabled to display the POST messages. Select Enabled to display the OEM logo instead of the normal POST messages. The options are **Enabled** and Disabled.

CSM Support

Select Enabled to support Compatibility Support Module (CSM) to enhance system security. The options are **Enabled** and Disabled.

AddOn ROM Display Mode

Use this item to set the display mode for the Option ROM. Select Keep Current to use the current AddOn ROM display setting. Select Force BIOS to use the Option ROM display mode set by the system BIOS. The options are **Force BIOS** and Keep Current.

Bootup Num-Lock State

Use this item to set the Power-on state for the Numlock key. The options are Off and **On**.

Wait For 'F1' If Error

Select Enabled to force the system to wait until the <F1> key is pressed when an error occurs. The options are Disabled and **Enabled**.

Interrupt 19 Capture

Interrupt 19 is the software interrupt that handles the boot disk function. When this item is set to Immediate, the ROM BIOS of the host adaptors will "capture" Interrupt 19 at bootup immediately and allow the drives that are attached to the host adaptors to function as bootable disks. If this item is set to Postponed, the ROM BIOS of the host adaptors will not capture Interrupt 19 immediately to allow the drives attached to the adaptors to function as bootable devices at bootup. The options are **Immediate** and Postponed.

Re-try Boot

Select EFI Boot to allow the BIOS to automatically reboot the system from an EFI boot device after the initial boot failure. Select Legacy Boot to allow the BIOS to automatically reboot the system from a Legacy boot device after its initial boot failure. The options are **Disabled**, Legacy Boot, and EFI Boot.

Power Configuration**Watch Dog Function**

Select Enabled to allow the Watch Dog timer to reboot the system when it is inactive for more than 5 minutes. The options are Enabled and **Disabled**.

Power Button Function

This feature controls how the system shuts down when the power button is pressed. Select 4 Seconds Override for the system to power off after the user presses and holds the power button for 4 seconds or longer. Select Instant Off to instantly power off the system as soon as the user presses the power button. The options are 4 Seconds Override and **Instant Off**.

Restore on AC Power Loss

Use this feature to set the power state after a power outage. Select Power Off for the system power to remain off after a power loss. Select Power On for the system power to be turned on after a power loss. Select Last State to allow the system to resume its last power state before a power loss. The options are Power On, Stay Off, and **Last State**.

►CPU Configuration

This submenu displays the following CPU information as detected by the BIOS. It also allows the user to configure CPU settings.

- Processor Socket
- Processor ID
- Processor Frequency
- Processor Max Ratio
- Processor Min Ratio
- Microcode Revision
- L1 Cache RAM
- L2 Cache RAM
- L3 Cache RAM
- Processor 0 Version
- Processor 1 Version

Clock Spread Spectrum

Select Enabled to allow the BIOS to attempt to reduce the level of Electromagnetic Interference caused by the components whenever needed. The options are **Disabled** and Enabled.

Hyper-Threading (All)

Select Enable to support Intel's Hyper-threading Technology to enhance CPU performance. The options are **Enable** and Disable.

Cores Enabled

This feature allows the user to determine the number of CPU cores to be enabled. Enter "0" to enable all cores. The default setting is **0**, which enables all CPU cores in the system.

Execute Disable Bit (Available if supported by the OS & the CPU)

Select Enable for Execute Disable Bit Technology support, which will allow the processor to designate areas in the system memory where an application code can execute and where it cannot, thus preventing a worm or a virus from flooding

illegal codes to overwhelm the processor to damage the system during an attack. The options are **Enable** and Disable. (Refer to Intel's and Microsoft's websites for more information.)

PPIN Control

Select Unlock/Enable to use the Protected-Processor Inventory Number (PPIN) control in the system. The options are **Unlock/Enable** and Unlock/Disable.

Hardware Prefetcher (Available when supported by the CPU)

If set to Enable, the hardware prefetcher will prefetch streams of data and instructions from the main memory to the L2 cache to improve CPU performance. The options are Disable and **Enable**.

Adjacent Cache Prefetch (Available when supported by the CPU)

Select Enable for the CPU to prefetch both cache lines for 128 bytes as comprised. Select Disable for the CPU to prefetch both cache lines for 64 bytes. The options are Disable and **Enable**.

 **Note:** Please reboot the system for the changes made on this setting to take effect. Please refer to Intel's website for detailed information.

DCU (Data Cache Unit) Streamer Prefetcher (Available when supported by the CPU)

If set to Enable, the DCU Streamer prefetcher will prefetch data streams from the cache memory to the DCU (Data Cache Unit) to speed up data accessing and processing to enhance CPU performance. The options are Disable and **Enable**.

DCU IP Prefetcher

If set to Enable, the IP prefetcher in the DCU (Data Cache Unit) will prefetch IP addresses to improve network connectivity and system performance. The options are **Enable** and Disable.

Direct Cache Access (DCA)

Select Enable to use Intel DCA (Direct Cache Access) Technology to improve the efficiency of data transferring and accessing. The options are **Auto**, Enable, and Disable.

X2APIC (Advanced Programmable Interrupt Controller)

Based on Intel's Hyper-Threading architecture, each logical processor (thread) is assigned 256 APIC IDs (APIDs) in 8-bit bandwidth. When this feature is set to Enable, the APIC ID will expand(X2) from 8 bits to 16 bits to provide 512 APIDs to each thread to enhance CPU performance. The options are **Disable** and Enable.

AES-NI

Select Enable to use the Intel Advanced Encryption Standard (AES) New Instructions (NI) to ensure data security. The options are **Enable** and Disable.

Intel Virtualization Technology

Select Enable to use Intel Virtualization Technology for Direct I/O VT-d support by reporting the I/O device assignments to the VMM (Virtual Machine Monitor) through the DMAR ACPI tables. This feature offers fully-protected I/O resource sharing across Intel platforms, providing greater reliability, security and availability in networking and data-sharing. The options are **Enable** and Disable.

► Advanced Power Management Configuration

Advanced Power Management Configuration

Power Technology

Select Energy Efficient to support power-saving mode. Select Custom to customize system power settings. Select Disable to disable power-saving settings. The options are Disable, **Energy Efficient**, and Custom.

Energy Performance Tuning

Select Enable for energy-performance tuning support to enhance energy efficiency, which might compromise system performance. The options are Enable and **Disable**.

Energy Performance BIAS Setting

Use this feature to select an appropriate power setting and performance level for the system. Select Performance to maximize system performance by using maximum amount of power. Select Balanced Performance to downgrade system performance a notch by using less power. Select Power to maximize power saving, which may greatly compromise system performance as a result. Select Balanced Power to downgrade power saving a notch and allow the system to use more power to boost system performance. The options are Performance, **Balanced Performance**, Balanced Power, and Power.

Energy Efficiency Turbo

Select Enable for the system to operate at turbo mode with reduced power consumption so that your machine can achieve maximum system performance with the maximum power efficiency possible. The options are **Enable** and Disable.

**If the option is set to Custom, the following items will display:*

► CPU P State Control (Available when Power Technology is set to Custom)

EIST (P-states)

EIST (Enhanced Intel SpeedStep Technology) allows the system to automatically adjust processor voltage and core frequency to reduce power consumption and heat dissipation. The options are Disable and **Enable**.

Turbo Mode

Select Enable to use the Turbo Mode to boost system performance. The options are **Enable** and Disable.

P-state Coordination

This item is used to change the P-state (Power-Performance State) coordination type. P-state is also known as "SpeedStep" for Intel processors. Select HW_ALL to change the P-state coordination type for hardware components only. Select SW_ALL to change the P-state coordination type for all software installed in the system. Select SW_ANY to change the P-state coordination type for a software program in the system. The options are **HW_All**, SW_ALL, and SW_ANY.

► CPU C State Control (Available when Power Technology is set to Custom)

Package C State limit

Use this item to set the limit on the C-State package register. The options are C0/1 state, C2 state, **C6 (non-Retention) state**, and C6 (Retention) state.

CPU C3 Report

Select Enable to allow the BIOS to report the CPU C3 state (ACPI C2) to the operating system. During the CPU C3 state, the CPU clock generator is turned off. The options are Enable and **Disable**.

CPU C6 Report (Available when Power Technology is set to Custom)

Select Enable to allow the BIOS to report the CPU C6 state (ACPI C3) to the operating system. During the CPU C6 state, power to all cache is turned off. The options are **Enable** and Disable.

Enhanced Halt State (C1E)

Select Enable to use the "Enhanced Halt State" feature, which will significantly reduce the CPU's power consumption by reducing CPU's clock cycle and voltage during a "Halt State." The options are Disable and **Enable**.

▶ CPU T State Control (Available when Power Technology is set to Custom)

ACPI (Advanced Configuration Power Interface) T-States

If this item is set to Enable, CPU throttling will be supported by the operating system to reduce power consumption. The options are **Enable** and Disable.

▶ Chipset Configuration

Warning! Please set the correct settings for the items below. A wrong configuration setting may cause the system to malfunction.

▶ North Bridge

This feature allows the user to configure the settings for the Intel North Bridge.

▶ IIO Configuration

EV DFX (Device Function On-Hide) Features

When this feature is set to Enable, the EV_DFX Lock Bits that are located on a processor will always remain clear during electric tuning. The options are **Disable** and Enable.

Snoop Response Hold Off

Use this option to set the snoop response hold-off value. The default setting is **6 Cycles**.

▶ IIO0 Configuration/IIO1 Configuration

IOU2 (IIO PCIe Port 1)

This item configures the PCI-E port Bifurcation setting for a PCI-E port specified by the user. The options are x4x4, **x8**, and Auto.

IOU0 (IIO PCIe Port 2)

This item configures the PCI-E port Bifurcation setting for a PCI-E port specified by the user. The options are x4x4x4x4, x4x4x8, x8x4x4, x8x8, **x16**, and Auto.

IOU1 (IIO PCIe Port 3)

This item configures the PCI-E port Bifurcation setting for a PCI-E port specified by the user. The options are x4x4x4x4, x4x4x8, x8x4x4, **x8x8**, x16, and Auto. The default setting for IIO0 IOU1 (IIO PCI-E Port 3) is **x16**, and the default setting of IIO1 IOU1 (IIO PCI-E Port 3) is **x8x8**.

► Socket 0 PciD00F0 - Port 0/DMI (for IIO0 Configuration)**► Socket 1 PciD00F0 - Port 0/DMI (for IIO1 Configuration)****PCI-E Port (Available for the IIO1 Configuration only)**

Select Enable to enable a PCI-E port specified by the user. Select Disable to de-activate a PCI-E port specified by the user. Select Auto for the BIOS ROM to automatically discard a PCI-E port specified by the user when there is no HP-compatible device connected to this port or when there is no error detected in this port. The options are **Auto**, Enable, and Disable.

Hot Plug Capable (Available for the IIO1 Configuration only)

Use this item to enable or disable Hot-Plug support for a port specified by the user. The options are **Disable** and Enable.

PCI-E Port Link (Available for the IIO1 Configuration only)

Use this item to disable the physical link connected to a PCI-E port specified by a user so that no training will take place on the component-level while the PCI-E configuration commands are still in full force. The options are **Enable** and Disable.

Link Speed

This item configures the link speed of a PCI-E port specified by the user. The options are Gen 1 (Generation 1) (2.5 GT/s), Gen 2 (Generation 2) and **Auto**.

Override Max Link Width

Use this item to enter a value that overrides the maximum link width set by PCI-E bifurcation for a PCI-E port specified by the user. The options are x1, x2, x4, x8, x16, and **Auto**.

PCI-E Port DeEmphasis

This item configures the De-Emphasis Control (LANKCON2 [6]) setting for this computer. The options are **-0.6 dB** and -3.5 dB.

PCI-E Port L0s Exit Latency

Use this feature to set the length of time required for the port specified by the user to complete the transition from L0s to L0. The default setting is **4uS - 8uS**.

PCI-E Port L1 Exit Latency

Use this feature to set the length of time required for the port specified by the user to complete the transition from L1 to L0. The options are: <1uS, 1uS - 2uS, 2uS - 4uS, 4uS - 8uS, **8uS - 16uS**, 16uS - 32uS, 32uS - 64uS, and >64uS.

Fatal Err (Error) Over

Select Enable to force a fatal error that has occurred to the port specified by the user to be prorogated to the IIO core error logic. The options are **Disable** and Enable.

Non-Fatal Err (Error) Over

Select Enable to force a non-fatal error that has occurred to the port specified by the user to be prorogated to the IIO core error logic. The options are **Disable** and Enable.

Corr Err (Correctable Error) Over

Select Enable to force a correctable error that has occurred to the port specified by the user to be prorogated to the IIO core error logic. The options are **Disable** and Enable.

L0s Support

When this item is set to Disable, IIO will not put its transmitter in the L0s state. The options are **Disable** and Enable.

▶Socket 0 PceiD01F0 - Port 1A/Socket 0 PceiD02F0 - Port 2A/Socket 0 PceiD03F0 - Port 3A (for IIO0 Configuration)

▶Socket 1 PceiD01F0 - Port 1A/Socket 1 PceiD02F0 - Port 2A/Socket 1 PceiD03F0 - Port 3A/Socket 1 PceiD03F2 - Port 3C (for IIO1 Configuration)

PCI-E Port (Available for the IIO1 Configuration only)

Select Enable to enable a PCI-E port specified by the user. Select Disable to de-activate a PCI-E port specified by the user. Select Auto for the BIOS ROM to automatically discard a PCI-E port specified by the user when there is no HP-compatible device connected to this port or when there is no error detected in this port. The options are **Auto**, Enable, and Disable.

Hot Plug Capable (Available for the IIO1 Configuration only)

Use this item to enable or disable Hot-Plug support for a port specified by the user. The options are **Disable** and Enable.

PCI-E Port Link (Available for the IIO1 Configuration only)

Use this feature to disable the physical link connected to a PCI-E port specified by a user so that no training will take place on the component-level while the PCI-E configuration commands are still in full force. The options are **Enable** and Disable.

Link Speed

This item configures the link speed of a PCI-E port specified by the user. The options are Gen 1 (Generation 1) (2.5 GT/s), Gen 2 (Generation 2) and **Auto**.

Override Max Link Width

Use this item to enter a value that overrides the maximum link width set by PCI-E bifurcation for a PCI-E port specified by the user. The options are x1, x2, x4, x8, x16, and **Auto**.

PCI-E Port DeEmphasis

This item configures the De-Emphasis Control (LANKCON2 [6]) setting for this computer. The options are **-0.6 dB** and -3.5 dB.

PCI-E Port L0s Exit Latency

Use this feature to set the length of time required for the port specified by the user to complete the transition from L0s to L0. The default setting is **4uS - 8uS**.

PCI-E Port L1 Exit Latency

Use this feature to set the length of time required for the port specified by the user to complete the transition from L1 to L0. The options are: <1uS, 1uS - 2uS, 2uS - 4uS, 4uS - 8uS, **8uS - 16uS**, 16uS - 32uS, 32uS - 64uS, and >64uS.

Fatal Err (Error) Over

Select Enable to force a fatal error that has occurred to the port specified by the user to be prorogated to the IIO core error logic. The options are **Disable** and Enable.

Non-Fatal Err (Error) Over

Select Enable to force a non-fatal error that has occurred to the port specified by the user to be prorogated to the IIO core error logic. The options are **Disable** and Enable.

Corr Err (Correctable Error) Over

Select Enable to force a correctable error that has occurred to the port specified by the user to be prorogated to the IIO core error logic. The options are **Disable** and Enable.

L0s Support

When this item is set to Disable, IIO will not put its transmitter in the L0s state. The options are **Disable** and Enable.

PM ACPI Mode

Select Enable to generate an _HPGPE message on a PM ACPI event. Select Disable to generate an MSI message. The options are **Disable** and Enable.

Gen3 (Generation 3) Eq (Equalization) Mode

Use this item to set PCI-E Gen3 Adaptive Equalization mode. The options are **Auto**, Enable Phase 0, 1, 2, 3; Disable Phase 0, 1, 2, 3; Enable Phase 1 Only, Enable Phase 0, 1 Only, Advanced, Enable MMM Offset West, and Alt Short Channel.

Gen3 (Generation 3) Spec (Specifics) Mode

Use this item to set the Specifics mode for a PCI-E Gen. 3 device. The options are **Auto**, 0.70 July, 0.70 Sept and 071 Sept.

Gen3 (Generation 3) Phase2 Mode

Use this feature to configure the Loop-count settings for PCI-E Gen3 Phase 2. The options are **Hardware Adaptive** and Manual.

Gen3 DN Tx Preset

Use this item to select the preset setting for a downstream component transmitter. The options are P0 (-6.0/0.0 dB), P1 (-3.5/0.0 dB), P2 (-4.5/0.0 dB), P3 (-2.5/0.0 dB), P4 (0.0/0.0 dB), P5 (0.0/-2.0 dB), P6 (0.0/-2.5 dB), P7 (-6.0/-3.5 dB), P8 (-3.5/-3.5 dB), P9 (0.0/-3.5 dB), and **Auto**.

Gen3 DN Rx Preset Hint

Use this item to select a preset setting for a downstream component receiver. The options are P0 (-6.0 dB), P1 (-7.0 dB), P2 (-8.0 dB), P3 (-9.0 dB), P4 (-10.0 dB), P5 (-11.0 dB), P6 (-12.0 dB), and **Auto**.

Gen3 UP Tx Preset

Use this item to select the preset setting for an upstream component transmitter. The options are P0 (-6.0/0.0 dB), P1 (-3.5/0.0 dB), P2 (-4.5/0.0 dB), P3 (-2.5/0.0 dB), P4 (0.0/0.0 dB), P5 (0.0/-2.0 dB), P6 (0.0/-2.5 dB), P7 (-6.0/-3.5 dB), P8 (-3.5/-3.5 dB), P9 (0.0/-3.5 dB), and **Auto**.

Hide Port?

Use this item to hide the root port from the operating system. The options are **No** and yes.

IOU0 Non-Posted Prefetch/IOU1 Non-Posted Prefetch/IOU2 Non-Posted Prefetch

Select Enable to enable Non-Posted Prefetch support for a PCI-E slot specified by the user. The options are **Disable** and Enable.

► IOAT Configuration

Enable IOAT

Select Enable to enable Intel I/OAT (I/O Acceleration Technology, which significantly reduces CPU overhead by leveraging CPU architectural improvements and freeing the system resource for other tasks. The options are **Enable** and Disable.

No Snoop

Select Enable to support no-snoop mode for each CB device. The options are **Disable** and Enable.

Relaxed Ordering

Select Enable for relaxed ordering support, which will allow certain transactions to be processed and completed prior to other transactions that have already been queued by overriding the strict ordering rules of PCI processing. The options are **Disable** and Enable.

► Intel VT for Directed I/O (VT-d)

Intel VT for Directed I/O (VT-d)

Select Enable to use the Intel Virtualization Technology for Direct I/O VT-d support by reporting the I/O device assignments to the VMM (Virtual Machine Monitor) through the DMAR ACPI tables. This feature offers fully-protected I/O resource sharing across Intel platforms, providing greater reliability, security and availability in networking and data-sharing. The options are **Enable** and Disable.

ACS Control

This item determines how to use the Access Control Service (ACS) in the system. ACS control provides an easy way of authenticating and authorizing for the user to gain access to web applications and services. Select Enable to achieve ACS Control via software programming. Select Disable to obtain ACS control by managing PCI-E bridge connections. The options are **Enable** and Disable.

Interrupt Remapping

Select Enable for Interrupt Remapping support to enhance system performance. The options are **Enable** and Disable.

► QPI (Quick Path Interconnect) Configuration

► QPI General Configuration

► QPI Status

The following information will display:

- Number of CPU
- Number of IIO
- Current QPI Link Speed
- Current QPI Link Frequency
- QPI Global MMIO Low Base/Limit
- QPI Global MMIO High Base/Limit
- QPI PCIe Configuration Base/Size

Link Frequency Select

Use this item to select the desired frequency for QPI Link connections. The options are 6.4GB/s, 8.0GB/s, 9.6GB/s, **Auto**, and Auto Limited.

Link L0p Enable

Select Enable for Link L0p support to reduce power consumption. The options are **Enable** and Disable.

Link L1 Enable

Select Enable for Link L1 support to reduce power consumption. The options are **Enable** and Disable.

Early Snoop (Available when the OS and the CPU support this feature)

Select Enable for Early Snoop support to enhance system performance. The options are Enable, Disable, and **Auto**.

Home Dir (Direct) Snoop with IVT-Style OSB (Available when the OS and the CPU support this feature)

Home Dir Snoop with IVT-Style OSB (Available when the OS and the CPU support this feature)

Select Enable for Home-Direct Snoop with IVT-Style_OSB support to enhance system performance. The options are Enable, Disable, and **Auto**.

Isoc Mode

Select Enable for Isochronous support to meet QoS (Quality of Service) requirements. This feature is especially important for Intel's Virtualization Technology. The options are Enable and **Disable**.

►Memory Configuration

This submenu allows the user to configure Integrated Memory Controller (IMC) settings.

Enforce POR

Select Enabled to enforce POR restrictions on DDR4 frequency and voltage programming. The options are **Enabled** and Disabled.

Memory Frequency

Use this item to set the maximum memory frequency for onboard memory modules. The options are **Auto**, 1333, 1400, 1600, 1800, 1867, 2000, 2133, 2200, 2400, 2600, 2667, 2800, 2933, 3000, 3200, and Reserved.

Data Scrambling

Select Enabled to enable data scrambling to enhance system performance and data integrity. The options are **Auto**, Disabled and Enabled.

Enable ADR

Select Enabled for ADR (Automatic Diagnostic Repository) support to enhance memory performance. The options are **Enabled** and Disabled.

Erase-Arm NVDIMMs (Non-Volatile DIMMs)

Non-volatile memory modules use flash memory to save data by erasing the old data first before. When this item is set to Enabled, BIOS will erase the flash memory of NVDIMMs and make NVDIMMs ready to save data. The options are **Enabled** and Disabled.

Restore NVDIMMs (Non-Volatile DIMMs)

Select Enabled for the NVDIMM modules to be automatically restored. The options are **Enabled** and Disabled.

Interleave NVDIMMs (Non-Volatile DIMMs)

Select Enabled for interleaving mode support for the onboard NVDIMM modules. The options are **Disabled** and Enabled.

ACPI Shutdown Trigger ADR

If this feature is set to Enabled, the AMI BIOS will issue a command to the Baseboard controller (BMC), which will allow the BMC to override the 4-second gracefully shutdown default setting and to trigger the ADR (Automatic Diagnostic Repository) command. The options are **Disabled** and Enabled.

DRAM RAPL (Running Average Power Limit) Baseline

Use this feature to set the run-time power-limit baseline for DRAM modules. The options are Disable, DRAM RAPL Mode 0, and **DRAM RAPL Mode 1**.

Set Throttling Mode

Throttling improves CPU reliability and reduces power consumption via automatic-voltage control during CPU idle states. The options are Disabled and **CLTT** (Closed Loop Thermal Throttling).

Socket Interleave Below 4GB

Select Enable for the memory above the 4G Address space to be split between two sockets. The options are **Disable** and Enable.

A7 Mode

Select Enable to support A7 (Addressing) mode to improve memory performance. The options are **Enable** and Disable.

►DIMM Information

This item displays the status of a DIMM module as detected by the AMI BIOS.

- P1 DIMMA1 ~ P2 DIMMH1

►Memory RAS (Reliability_Availability_Serviceability) Configuration

Use this submenu to configure the following Memory RAS settings.

RAS Mode

When Mirror is selected, the motherboard maintains two identical copies of all data in memory for data backup. When Lockstep is selected, the motherboard uses two areas of memory to run the same set of operations in parallel to boost performance. Select Disable to disable Mirror and Lockstep mode support. The options are **Disable**, Mirror, and Lockstep Mode.

Memory Rank Sparing

Select Enable to enable memory-sparing support for memory ranks to improve memory performance. The options are **Disabled** and **Enabled**.

Patrol Scrub

Patrol Scrubbing is a process that allows the CPU to correct correctable memory errors detected on a memory module and send the corrections to the requestor (the original source). When this item is set to Enable, the IO hub will read and write back one cache line every 16K cycles if there is no delay caused by internal processing. By using this method, roughly 64 GB of memory behind the IO hub will be scrubbed every day. The options are **Enable** and **Disable**.

Patrol Scrub Interval

This feature allows you to decide how many hours the system should wait before the next complete patrol scrub is performed. Use the keyboard to enter a value from 0-24. The Default setting is **24**.

Demand Scrub

Demand Scrubbing is a process that allows the CPU to correct correctable memory errors found on a memory module. When the CPU or I/O issues a demand-read command, and the read data from memory turns out to be a correctable error, the error is corrected and sent to the requestor (the original source). Memory is updated as well. Select Enable to use Demand Scrubbing for ECC memory correction. The options are **Enable** and **Disable**.

Device Tagging

Select Enable to support device tagging. The options are **Disable** and **Enable**.

►South Bridge Configuration

The following South Bridge information will display:

►USB Configuration

- USB Module Version
- USB Devices

Legacy USB Support

Select Enabled to support onboard legacy USB devices. Select Auto to disable legacy support when there are no legacy USB devices present. Select Disabled to have all USB devices available for EFI applications only. The options are **Enabled**, **Disabled** and **Auto**.

XHCI Hand-Off

This is a work-around solution for operating systems that do not support XHCI (Extensible Host Controller Interface) hand-off. The XHCI ownership change should be claimed by the XHCI driver. The settings are **Enabled** and Disabled.

EHCI Hand-Off

This item is for operating systems that do not support Enhanced Host Controller Interface (EHCI) hand-off. When this item is enabled, EHCI ownership change will be claimed by the EHCI driver. The settings are Enabled and **Disabled**.

Port 60/64 Emulation

Select Enabled to support I/O port 60h/64h emulation, which will provide complete legacy USB keyboard support for the operating systems that do not support legacy USB devices. The options are Disabled and **Enabled**.

USB 3.0 Support

Select Enabled for USB 3.0 support. The options are Smart Auto, **Auto**, Enabled, and Disabled.

►SATA Configuration

When this submenu is selected, AMI BIOS automatically detects the presence of the SATA devices that are supported by the Intel PCH chip and displays the following items:

SATA Controller

This item enables or disables the onboard SATA controller supported by the Intel PCH chip. The options are **Enabled** and Disabled.

Configure SATA as

Select IDE to configure a SATA drive specified by the user as an IDE drive. Select AHCI to configure a SATA drive specified by the user as an AHCI drive. Select RAID to configure a SATA drive specified by the user as a RAID drive. The options are IDE, **AHCI**, and RAID.

**If the item above "Configure SATA as" is set to AHCI, the following items will display:*

SATA Port 0~ Port 5

This item displays the information detected on the installed SATA drive on the particular SATA port.

- Model number of drive and capacity
- Software Preserve Support

Port 0~ Port 5

Select Enabled to enable a SATA port specified by the user. The options are Disabled and **Enabled**.

Port 0 ~ Port 5 Hot Plug

Select Enabled to enable hot-plugging for a port specified by the user, which will allow the user to replace a SATA disk drive installed on this port without shutting down the system. The options are **Enabled** and Disabled.

Port 0 ~ Port 5 Spin Up Device

On an edge detect from 0 to 1, set this item to allow the PCH to initialize the device. The options are Enabled and **Disabled**.

Port 0 ~ Port 5 SATA Device Type

Use this item to specify if the SATA port specified by the user should be connected to a Solid State drive or a Hard Disk Drive. The options are **Hard Disk Drive** and Solid State Drive.

**If the item above "Configure SATA as" is set to IDE, the following items will display:*

Serial ATA Port 0~ Port 5

This item indicates if a SATA port specified by the user is installed (present) or not.

Port 0 ~ Port 5 SATA Device Type (Available when a SATA port is detected)

Use this item to specify if the SATA port specified by the user should be connected to a Solid State drive or a Hard Disk Drive. The options are **Hard Disk Drive** and Solid State Drive.

**If the item above "Configure SATA as" is set to RAID, the following items will display:*

SATA RAID Option ROM/UEFI Driver

Select EFI to load the EFI driver for system boot. Select Legacy to load a legacy driver for system boot. The options are Disabled, EFI, and **Legacy**.

SATA/sSATA RAID Boot Select

Select SATA Controller to boot the system from a SATA RAID device. Select sSATA Controller to boot the system from a sSATA RAID device. Select Both to boot the system either from a SATA RAID device or from an sSATA RAID device. Please note that the option-Both is not supported by the Windows Server 2012/R2 OS. The options are None, Both, SATA Controller, and **sSATA Controller**.

►sSATA Configuration

When this submenu is selected, AMI BIOS automatically detects the presence of the s-SATA devices that are supported by the PCH-sSATA controller and displays the following items:

sSATA Controller

This item enables or disables the onboard SATA controller supported by the Intel PCH chip. The options are **Enabled** and Disabled.

Configure sSATA as

Select IDE to configure an sSATA drive specified by the user as an IDE drive. Select AHCI to configure an sSATA drive specified by the user as an AHCI drive. Select RAID to configure an sSATA drive specified by the user as a RAID drive. The options are IDE, **AHCI**, and RAID.

**If the item above "Configure sSATA as" is set to AHCI, the following items will display:*

sSATA Port 0~ Port 3

This item displays the information detected on the installed on the sSATA port. specified by the user.

- Model number of drive and capacity

sSATA Port 0~ Port 3

Select Enabled to enable an sSATA port specified by the user. The options are Disabled and **Enabled**.

sSATA Port 0 ~ Port 3 Hot Plug

Select Enabled to enable hot-plugging support for a port specified by the user, which will allow the user to replace a sSATA disk drive installed on this port without shutting down the system. The options are **Enabled** and Disabled.

Configure as eSATA (Available for the sSATA Port 0 Only)

Select Enabled to configure sSATA Port 0 as an external sSATA port. The options are Enabled and **Disabled**.

sSATA Port 0 ~ Port 3 Spin Up Device

On an edge detect from 0 to 1, set this item to allow the PCH to start a COMRESET initialization to the device. The options are Enabled and **Disabled**.

Port 0 ~ Port 3 sSATA Device Type

Use this item to specify if the sSATA port specified by the user should be connected to a Solid State drive or a Hard Disk Drive. The options are **Hard Disk Drive** and Solid State Drive.

**If the item above "Configure sSATA as" is set to IDE, the following items will display:*

sSATA Port 0~ Port 3

This item indicates that an sSATA port specified by the user is installed (present) or not.

Port 0~ Port 3 sSATA Device Type (Available when a sSATA port is detected)

Use this item to specify if the sSATA port specified by the user should be connected to a Solid State drive or a Hard Disk Drive. The options are **Hard Disk Drive** and Solid State Drive.

**If the item above "Configure sSATA as" is set to RAID, the following items will display:*

sSATA RAID Option ROM/UEFI Driver

Select EFI to load the EFI driver for system boot. Select Legacy to load a legacy OPROM for system boot. The options are Disabled, EFI, and **Legacy**.

SATA/sSATA RAID Boot Select

Select SATA Controller to boot the system from a SATA RAID device. Select sSATA Controller to boot the system from a sSATA RAID device. Select Both to boot the system either from a SATA RAID device or from an sSATA RAID device. Please note that the option-Both is not supported by the Windows Server 2012/R2 OS. The options are None, Both, SATA Controller, and **sSATA Controller**.

sSATA Port 0 ~ Port 3 Hot Plug

Select Enabled to enable hot-plugging support for a port specified by the user, which will allow the user to replace a sSATA disk drive installed on this port without shutting down the system. The options are **Enabled** and Disabled.

Configure as eSATA (Available for the sSATA Port 0 Only)

Select Enabled to configure sSATA Port 0 as an external sSATA port. The options are Enabled and **Disabled**.

sSATA Port 0 ~ Port 3 Spin Up Device

On an edge detect from 0 to 1, set this item to allow the PCH to start a COMRESET initialization to the device. The options are Enabled and **Disabled**.

Port 0 ~ Port 3 sSATA Device Type

Use this item to specify if the sSATA port specified by the user should be connected to a Solid State drive or a Hard Disk Drive. The options are **Hard Disk Drive** and Solid State Drive.

► Server ME (Management Engine) Configuration

This feature displays the following system ME configuration settings.

- General ME Configuration
- Operational Firmware Version
- ME Firmware Type
- Recovery Firmware Version
- ME Firmware Features
- ME Firmware Status #1
- ME Firmware Status #2
 - Current State
 - Error Code

► PCIe/PCI/PnP Configuration

PCI Latency Timer

Use this item to configure the PCI latency timer for a device installed on a PCI bus. Select 32 to set the PCI latency timer to 32 PCI clock cycles. The options are **32**, 64, 96, 128, 160, 192, 224 and 248 (PCI Bus Clocks).

PERR# Generation

Select Enabled for the BIOS to generate a PERR (PCI/PCI-E Parity Error) number. The options are Enabled and **Disabled**.

SERR# Generation

Select Enabled for the BIOS to generate a SERR (System Error) number. The options are Enabled and **Disabled**.

PCI PERR/SERR Support

Select Enabled to support PERR (PCI/PCI-E Parity Error)/SERR (System Error) runtime error reporting for a PCI/PCI-E slot. The options are Enabled and **Disabled**.

Above 4G Decoding (Available if the system supports 64-bit PCI decoding)

Select Enabled to decode a PCI device that supports 64-bit in the space above 4G Address. The options are Enabled and **Disabled**.

SR-IOV (Available if the system supports Single-Root Virtualization)

Select Enabled for Single-Root IO Virtualization support. The options are Enabled and **Disabled**.

Maximum Payload

Select Auto for the system BIOS to automatically set the maximum payload value for a PCI-E device to enhance system performance. The options are **Auto**, 128 Bytes, and 256 Bytes.

Maximum Read Request

Select Auto for the system BIOS to automatically set the maximum size for a read request for a PCI-E device to enhance system performance. The options are **Auto**, 128 Bytes, 256 Bytes, 512 Bytes, 1024 Bytes, 2048 Bytes, and 4096 Bytes.

ASPM Support

Use this item to set the Active State Power Management (ASPM) level for a PCI-E device. Select Auto for the system BIOS to automatically set the ASPM level based on the system configuration. Select Disabled to disable ASPM support. The options are **Disabled** and Auto.

Warning: Enabling ASPM support may cause some PCI-E devices to fail!

MMIOHBase

Use this item to select the I/O base memory size according to memory-address mapping for the PCH chip. The base memory size must be between 4032G to 4078G. The options are **56TB**, 40TB, 24T, 3T, 2T, and 1TB.

MMIO High Size

Use this item to select the high I/O memory size according to memory-address mapping for the PCH chip. The options are **256G**, 128G, 512G, and 1024G.

PCI Devices Option ROM Settings

Slot1 PCI-E OPROM

Use this item to select the Option ROM type for a device installed on PCI-E Slot1 for system boot. The options are Disabled, **Legacy**, and EFI.

Onboard Video Option ROM

Use this item to select the Option ROM type for the onboard video device for system boot. The options are Disabled, **Legacy**, and EFI.

VGA Priority

Use this item to select the graphics device to be used as the primary video display for system boot. The options are **Onboard** and Offboard.

Onboard LAN OPROM Type

This item allows the user to select Option ROM type for the network (LAN) connections. The options are **Legacy** and EFI.

Onboard LAN1 OPROM (Option ROM)/Onboard LAN2 OPROM (Option ROM)/Onboard LAN3 OPROM (Option ROM)/Onboard LAN4 OPROM (Option ROM)

Use this item to select the type of device installed in a LAN port specified by the user for system boot. The default setting for LAN1 Option ROM is **Enabled**. The default settings for LAN2-LAN4 Option ROMs are **Disabled**.

Onboard SAS OPROM Type

Use this item to select the Option ROM type for the SAS device specified by the user for system boot. The options are Disabled, **Legacy**, and EFI.

Network Stack

Select Enabled to enable PXE (Preboot Execution Environment) or UEFI (Unified Extensible Firmware Interface) for network stack support. The options are **Disabled** and Enabled. If this item is set to Enabled, the following items will display:

IPv4 PXE Support (Available when Network Stack is set to Enabled)

Set this item to Enabled to activate IPv4 PXE Support. The options are **Enabled** and Disabled.

IPv6 PXE Support (Available when Network Stack is set to Enabled)

Set this item to Enabled to activate IPv6 PXE Support. The options are Enabled and **Disabled**.

PXE Boot Wait Time(Available when Network Stack is set to Enabled)

Use this item to set the wait time for the BIOS to hold back PXE-boot from being executed when the user presses the ESC key. The default setting is **0**.

►Super IO Configuration**Super IO Chip AST2400****►Serial Port 1 Configuration/Serial Port 2 Configuration****Serial Port**

Select Enabled to enable the onboard serial port specified by the user. The options are **Enabled** and Disabled.

Device Settings

This item displays the base I/O port address and the Interrupt Request address for a serial port specified by the user. The default setting for Serial Port 1 is IO=3F8h IRQ=4, and for Serial Port 2 is IO=2F8h IRQ=3.

Change Port (1) Settings

This feature specifies the base I/O port address and the Interrupt Request address of Serial Port 1. Select **Auto** for the BIOS to automatically assign the base I/O and IRQ address to a serial port specified.

The options for Serial Port 1 are **Auto**, (IO=3F8h; IRQ=4), (IO=3F8h; IRQ=3, 4, 5, 6, 7, 10, 11, 12), (IO=2F8h; IRQ=3, 4, 5, 6, 7, 10, 11, 12); (IO=3E8h; IRQ=3, 4, 5, 6, 7, 10, 11, 12), and (IO=2E8h; IRQ=3, 4, 5, 6, 10, 11, 12).

The options for Serial Port 2 are **Auto**, (IO=2F8h; IRQ=3), (IO=3F8h; IRQ=3, 4, 5, 6, 7, 10, 11, 12), (IO=2F8h; IRQ=3, 4, 5, 6, 7, 10, 11, 12); (IO=3E8h; IRQ=3, 4, 5, 6, 7, 10, 11, 12), and (IO=2E8h; IRQ=3, 4, 5, 6, 7, 10, 11, 12).

Device Mode

Use this item to select the SUART Clock source for a serial port specified by the user. The options are **24MHz/13** and 24MHz.

Serial Port 2 Attribute (Available on the Serial Port 2 Configuration Only)

Select SOL to use COM Port 2 as a Serial_Over_LAN (SOL) port for console redirection. The options are COM and **SOL**.

►Serial Port Console Redirection

COM 1 Console Redirection

(COM 1) Console Redirection

Select Enabled to enable COM Port 1 Console Redirection, which will allow a client machine to be connected to a host machine at a remote site for networking. The options are **Disabled** and Enabled.

**If the item above set to Enabled, the following items will become available for configuration:*

►(COM1) Console Redirection Settings

Terminal Type

Use this item to select the target terminal emulation type for Console Redirection. Select VT100 to use the ASCII Character set. Select VT100+ to add color and function key support. Select ANSI to use the Extended ASCII Character set. Select VT-UTF8 to use UTF8 encoding to map Unicode characters into one or more bytes. The options are ANSI, VT100, **VT100+**, and VT-UTF8.

Bits Per second

Use this item to set the transmission speed for a serial port used in Console Redirection. Make sure that the same speed is used in the host computer and the client computer. A lower transmission speed may be required for long and busy lines. The options are 9600, 19200, 38400, 57600 and **115200** (bits per second).

Data Bits

Use this item to set the data transmission size for Console Redirection. The options are 7 (Bits) and **8 (Bits)**.

Parity

A parity bit can be sent along with regular data bits to detect data transmission errors. Select Even if the parity bit is set to 0, and the number of 1's in data bits is even. Select Odd if the parity bit is set to 0, and the number of 1's in data bits is odd. Select None if you do not want to send a parity bit with your data bits in transmission. Select Mark to add a mark as a parity bit to be sent along with the data bits. Select Space to add a Space as a parity bit to be sent with your data bits. The options are **None**, Even, Odd, Mark and Space.

Stop Bits

A stop bit indicates the end of a serial data packet. Select 1 Stop Bit for standard serial data communication. Select 2 Stop Bits if slower devices are used. The options are **1** and 2.

Flow Control

Use this item to set the flow control for Console Redirection to prevent data loss caused by buffer overflow. Send a "Stop" signal to stop sending data when the receiving buffer is full. Send a "Start" signal to start sending data when the receiving buffer is empty. The options are **None** and Hardware RTS/CTS.

VT-UTF8 Combo Key Support

Select Enabled to enable VT-UTF8 Combination Key support for ANSI/VT100 terminals. The options are **Enabled** and Disabled.

Recorder Mode

Select Enabled to capture the data displayed on a terminal and send it as text messages to a remote server. The options are **Disabled** and Enabled.

Resolution 100x31

Select Enabled for extended-terminal resolution support. The options are Disabled and **Enabled**.

Legacy OS Redirection Resolution

Use this item to select the number of rows and columns used in Console Redirection for legacy OS support. The options are **80x24 and 80x25**.

Putty KeyPad

Use this item to select Function Keys and KeyPad settings for Putty, which is a terminal emulator designed for the Windows OS. The options are **VT100**, LINUX, XTERMR6, SCO, ESCN, and VT400.

Redirection After BIOS Post

Use this item to enable or disable legacy Console Redirection after BIOS POST (Power-On Self-Test). When "Bootloader" is selected, legacy Console Redirection is disabled before booting the OS. When "Always Enable" is selected, legacy Console Redirection remains enabled while the OS boots up. The options are **Always Enable** and Bootloader.

COM2/SOL Console Redirection

(COM2/SOL) Console Redirection

Select Enabled to use the SOL port for Console Redirection. The options are **Enabled** and Disabled.

**If the item above set to Enabled, the following items will become available for user's configuration:*

►(COM2/SOL) Console Redirection Settings

Use this feature to specify how the host computer will exchange data with the client computer, which is the remote computer used by the user.

Terminal Type

Use this feature to select the target terminal emulation type for Console Redirection. Select VT100 to use the ASCII Character set. Select VT100+ to add color and function key support. Select ANSI to use the Extended ASCII Character Set. Select VT-UTF8 to use UTF8 encoding to map Unicode characters into one or more bytes. The options are ANSI, VT100, **VT100+**, and VT-UTF8.

Bits Per second

Use this feature to set the transmission speed for a serial port used in Console Redirection. Make sure that the same speed is used in the host computer and the client computer. A lower transmission speed may be required for long and busy lines. The options are 9600, 19200, 38400, 57600 and **115200** (bits per second).

Data Bits

Use this feature to set the data transmission size for Console Redirection. The options are 7 (Bits) and **8 (Bits)**.

Parity

A parity bit can be sent along with regular data bits to detect data transmission errors. Select Even if the parity bit is set to 0, and the number of 1's in data bits is even. Select Odd if the parity bit is set to 0, and the number of 1's in data bits is odd. Select None if you do not want to send a parity bit with your data bits in transmission. Select Mark to add a mark as a parity bit to be sent along with the data bits. Select Space to add a Space as a parity bit to be sent with your data bits. The options are **None**, Even, Odd, Mark and Space.

Stop Bits

A stop bit indicates the end of a serial data packet. Select 1 Stop Bit for standard serial data communication. Select 2 Stop Bits if slower devices are used. The options are **1** and 2.

Flow Control

Use this feature to set the flow control for Console Redirection to prevent data loss caused by the overflow in the buffer. Send a "Stop" signal to stop sending data when the receiving buffer is full. Send a "Start" signal to start data-sending when the receiving buffer is empty. The options are **None** and Hardware RTS/CTS.

VT-UTF8 Combo Key Support

Select Enabled to enable VT-UTF8 Combination Key support for ANSI/VT100 terminals. The options are **Enabled** and Disabled.

Recorder Mode

Select Enabled to capture the data displayed on a terminal and send it as text messages to a remote server. The options are **Disabled** and Enabled.

Resolution 100x31

Select Enabled for extended-terminal resolution support. The options are Disabled and **Enabled**.

Legacy OS Redirection Resolution

Use this feature to select the number of rows and columns used in Console Redirection for legacy OS support. The options are **80x24 and 80x25**.

Putty KeyPad

This feature selects Function Keys and KeyPad settings for Putty, which is a terminal emulator designed for the Windows OS. The options are **VT100**, LINUX, XTERMR6, SCO, ESCN, and VT400.

Redirection After BIOS Post

Use this feature to enable or disable legacy Console Redirection after BIOS POST (Power-On Self-Test). When this feature is set to Bootloader, legacy Console Redirection is disabled before booting the OS. When this feature is set to Always Enable, legacy Console Redirection remains enabled upon OS boot. The options are **Always Enable** and Bootloader.

Serial Port for Out-of-Band Management/Windows Emergency Management Services (EMS)

The submenu allows the user to configure Console Redirection settings to support Out-of-Band Serial Port management.

(EMS) Console Redirection

Select Enabled to use a COM port selected by the user for EMS Console Redirection. The options are Enabled and **Disabled**.

*If the item above set to Enabled, the following items will become available for user's configuration:

►EMS Console Redirection Settings (Available when EMS Console Redirection is enabled)

Use this feature to specify how the host computer will exchange data with the client computer, which is the remote computer used by the user.

Out-of-Band Management Port

The feature selects a serial port in a client server to be used by the Windows Emergency Management Services (EMS) to communicate with a remote host server. The options are COM1 (Console Redirection) and **COM2/SOL (Console Redirection)**.

Terminal Type

Use this feature to select the target terminal emulation type for Console Redirection. Select VT100 to use the ASCII character set. Select VT100+ to add color and function key support. Select ANSI to use the extended ASCII character set. Select VT-UTF8 to use UTF8 encoding to map Unicode characters into one or more bytes. The options are ANSI, VT100, VT100+, and **VT-UTF8**.

Bits Per Second

This item sets the transmission speed for a serial port used in Console Redirection. Make sure that the same speed is used in both host computer and the client computer. A lower transmission speed may be required for long and busy lines. The options are 9600, 19200, 57600, and **115200** (bits per second).

Flow Control

Use this item to set the flow control for Console Redirection to prevent data loss caused by buffer overflow. Send a "Stop" signal to stop data-sending when the receiving buffer is full. Send a "Start" signal to start data-sending when the receiving buffer is empty. The options are **None**, Hardware RTS/CTS, and Software Xon/Xoff.

The following settings will be displayed:

Data Bits, Parity, Stop Bits

► Enabling TPM in the BIOS

The steps below describe the proper procedure on how to enable the TPM in the BIOS. This process is necessary to activate support in the system before you can start using the TPM.

1. Enter the BIOS setup screen. You may do this either from the IPMI remote console or from the server directly using KVM. Reboot the system and press the key as the system boots until you reach the BIOS screen.
2. You will be presented with the BIOS setup main screen. Using the arrow keys, navigate to the Advanced tab. From there, navigate down and select the "CPU Configuration" option as shown below. Press <Enter>.

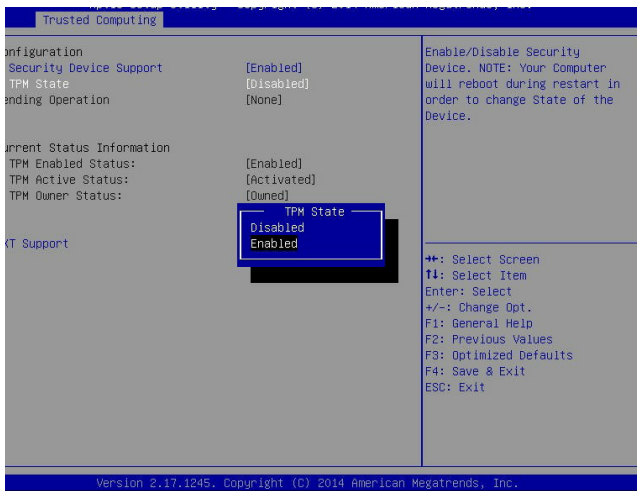

3. You will be taken to the CPU Configuration page. Using the arrow keys, navigate down to the "Intel Virtualization Technology" option and press <Enter>. Select "Enable" and press <Enter>.
4. Once you have enabled Virtualization support, press your <Esc> key until you are back to the Advanced tab. Navigate down to the "Trusted Computing" option and press <Enter>.
5. The Trusted Computing window will appear. Select "TPM State" and press <Enter>.
6. From the window that pops up, select "Enabled" and press <Enter>.
7. You must save your changes and reset for the changes to take effect. Scroll to the Save & Exit tab and select "Save Changes and Reset."

►Intel TXT (LT-SX) Configuration

This submenu allows the user to configure the following TXT settings.

TXT Support

Select Enabled to enable Intel Trusted Execution Technology (TXT) support. The options are **Disabled** and Enabled.

 **Note:** If the option for this item (TXT Support) is set to Enabled, be sure to disable EV DFX (Device Function On-Hide) support for the system to work properly. (EV DFX is under "I/O Configuration" in the "Chipset/ North Bridge" submenu. For more information on TPM, please refer to the TPM manual at http://www.supermicro.com/manuals/other/AOM-TPM-9655V_9655H.pdf

►ACPI Settings

WHEA Support

Select Enabled to support the Windows Hardware Error Architecture (WHEA) platform and provide a common infrastructure for the system to handle hardware errors within the Windows OS environment to reduce system crashes and to enhance system recovery and health monitoring. The options are **Enabled** and Disabled.

High Precision Event Timer

Select Enabled to activate the High Precision Event Timer (HPET) that produces periodic interrupts at a much higher frequency than a Real-time Clock (RTC) does in synchronizing multimedia streams, providing smooth playback and reducing the dependency on other timestamp calculation devices, such as an x86 RDTSC Instruction embedded in the CPU. The High Performance Event Timer is used to replace the 8254 Programmable Interval Timer. The options are **Enabled** and Disabled.

NUMA (Available when the OS supports this feature)

Select Enabled to enable Non-Uniform Memory Access support to enhance system performance. The options are **Enabled** and Disabled.

4-4 Event Logs

This submenu allows the user to configure Event Log settings.



► Change SMBIOS Event Log Settings

This feature allows the user to configure SMBIOS Event settings.

Enabling/Disabling Options

SMBIOS Event Log

Select Enabled to enable SMBIOS (System Management BIOS) Event Logging during system boot. The options are **Enabled** and Disabled.

Runtime Error Logging Support

Select Enable to support Runtime Error logging. The options are **Enabled** and Disabled. If this item is set to Enabled, the following item will be available for configuration:

Erasing Settings

Erase Event Log

Select Yes to erase all error events in the SMBIOS (System Management BIOS) log before an event logging is initialized at bootup. The options are **No**, Yes, Next reset, and Yes, every reset.

When Log is Full

Select Erase Immediately to immediately erase all errors in the SMBIOS event log when the event log is full. Select Do Nothing for the system to do nothing when the SMBIOS event log is full. The options are **Do Nothing** and Erase Immediately.

SMBIOS Event Log Standard Settings

Log System Boot Event

Select Enabled to log system boot events. The options are **Disabled** and Enabled.

MECI (Multiple Event Count Increment)

Enter the increment value for the multiple event counter. Enter a number between 1 to 255. The default setting is 1.

METW (Multiple Event Count Time Window)

This item is used to determine how long (in minutes) the multiple event counter should wait before generating a new event log. Enter a number between 0 to 99. The default setting is 60.



Note: Please reboot the system for the changes to take effect.

►View SMBIOS Event Log

This item allows the user to view the event in the SMBIOS event log. The following categories are displayed:

Date/Time/Error Code/Severity

4-5 IPMI

This submenu allows the user to configure IPMI settings.



The following items will be displayed:

- IPMI Firmware Revision
- Status of BMC

► System Event Log

Enabling/Disabling Options

SEL Components

Select Enabled to enable all system event logging support at bootup. The options are **Enabled** and Disabled.

Erasing Settings

Erase SEL

Select Yes, On next reset to erase all system event logs upon next system reboot.
 Select Yes, On every reset to erase all system event logs upon each system reboot.
 Select No to keep all system event logs after each system reboot. The options are **No**, Yes, On next reset, and Yes, On every reset.

When SEL is Full

This feature allows the user to determine what the AMI BIOS should do when the system event log is full. Select Erase Immediately to erase all events in the log when the system event log is full. The options are **Do Nothing** and Erase Immediately.

 **Note:** After making changes on a setting, be sure to reboot the system for the changes to take effect.

Custom EFI Logging Options

Log EFI Status Codes

Use this item to select the type of events to log. The options are Disabled, Both, **Error Code**, and Progress Codes.

 **Note:** After making changes on a setting, be sure to reboot the system for the changes to take effect.

►BMC Network Configuration

The following items will be displayed:

- IPMI LAN Selection
- IPMI Network Link Status

Update IPMI LAN Configuration

Select Yes for the system BIOS to automatically reset the following IPMI settings upon next system boot. The options are Yes and **No**.

Configuration Address Source (Available when the item above - Update IPMI LAN Configuration is set to Yes)

Use this item to select the IP address source for this computer. If Static is selected, you will need to know the IP address of this computer and enter it to the system manually in the field. If DHCP is selected, AMI BIOS will search for a DHCP (Dynamic Host Configuration Protocol) server attached to the network and request the next available IP address for this computer. The options are **DHCP** and Static.

Station IP Address

This item displays the Station IP address for this computer. This should be in decimal and in dotted quad form (i.e., 192.168.10.253).

Subnet Mask

This item displays the sub-network that this computer belongs to. The value of each three-digit number is separated by dots and it should not exceed 255.

Station MAC Address

This item displays the Station MAC address for this computer. Mac addresses are 6 two-digit hexadecimal numbers.

Gateway IP Address

This item displays the Gateway IP address for this computer. This should be in decimal and in dotted quad form (i.e., 192.168.10.253).

VLAN

Select Enabled to enable onboard LAN connections to be used for Intel Virtualization Technology. The options are Enable and **Disable**.

4-6 Security Settings

This submenu allows the user to configure the following security settings for the system.

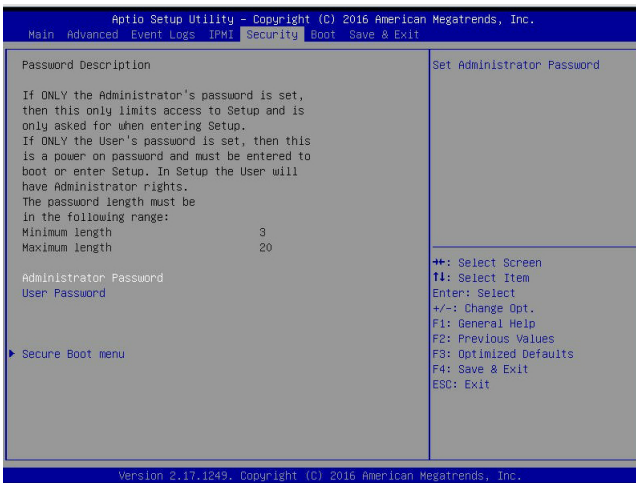

Password Check

Select Setup for the system to prompt for a password upon entering the BIOS setup utility. Select Always for the system to prompt for a password at bootup and upon entering the BIOS Setup utility. The options are **Setup** and Always.

Administrator Password

Use this feature to set the administrator password which is required before entering the BIOS setup utility. The length of the password should be from 3 characters to 20 characters long.

User Password (Available after an Administrator Password is entered)

Use this feature to set the user password which is required to enter the BIOS setup utility. The length of the password should be from 3 characters to 20 characters long.

►Secure Boot Menu

The following items will display:

- System Mode
- Secure Boot
- Vendor Keys

Secure Boot

Select Enable for secure boot support to ensure system security at bootup. The options are Enabled and **Disabled**.

Secure Boot Mode

This item allows the user to select the desired secure boot mode for the system. The options are Standard and **Custom**.

►Key Management

Provision Factory Default Keys

Select Enable to install all manufacturer default keys for the system security settings. The options are **Disabled** and Enabled.

►Enroll All Factor Default Keys

Select Enable to install all manufacturer defaults for the system security settings. The options are **Yes** and No.

►Save All Secure Boot Variables

This feature allows the user to set and save the Secure Boot Variable settings:

►Platform Key (PK)

This feature allows the user to configure and save platform key settings.

► Key Exchange Key

This feature allows the user to configure and save Key-Exchange-Key settings.

► Authorized Signatures

This feature allows the user to set and save authorized signatures and grant access to those whose names appear on the list.

► Forbidden Signatures

This feature allows the user to set and save the forbidden signatures and deny the access to those whose names appear on the list.

► Authorized TimeStamps

This feature allows the user to set and save the timestamps for authorized signatures to indicate when these signatures were entered into the system.

4-7 Boot Settings

This submenu allows the user to configure Boot settings for this system:

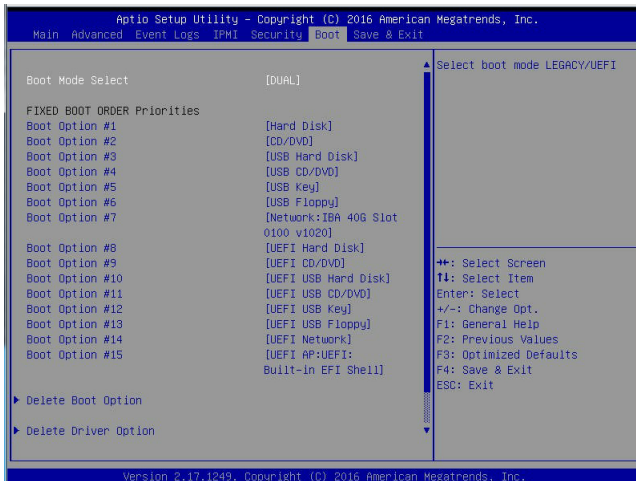

Boot Configuration

Boot Mode Select

Use this item to select the type of device to be used for system boot. The options are Legacy, UEFI, and **Dual**.

Fixed Boot Order Priorities

This option prioritizes the order of bootable devices from which the system will boot. Press <Enter> on each entry from top to bottom to select devices.

When the item above -"Boot Mode Select" is set to **Dual** (default), the following items will be displayed for configuration:

- Boot Option #1 - Boot Option #15

When the item above -"Boot Mode Select" is set to Legacy, the following items will be display for configuration:

- Boot Option #1 - Boot Option #7

When the item above -"Boot Mode Select" is set to UEFI, the following items will be display for configuration:

- Boot Option #1 - Boot Option #8

►Add New Boot Option

Use this item to select a new boot device to add to the boot priority list.

Add New Boot Option

Use this feature to select the target boot device to add to the boot priority list.

Path for Boot Option

Use this feature to create a new path for boot option.

Boot Option File Path

Use this feature to set a new file path for boot option.

Create

Use this feature to create a new boot option for the new device.

►Delete Boot Option

Use this item to select a boot device to delete from the boot priority list.

Delete Boot Option

Select the target boot device to delete from the boot priority list.

▶ Hard Disk Drive BBS Priorities

- Legacy Boot Order #1

▶ Network Drive BBS Priorities

- Legacy Boot Order #1 - # 8

▶ USB Key Drive BBS Priorities

- Legacy Boot Order #1

▶ UEFI USB Key Drive BBS Priorities

- UEFI Boot Order #1

4-8 Save & Exit

This submenu allows the user to configure the following Save & Exit settings:

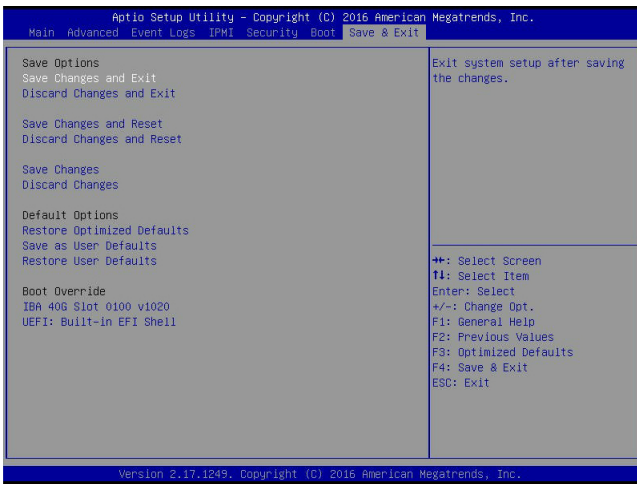

Save Options

Save Changes and Exit

Select this item to save the changes you've made and to exit from the BIOS setup. For the changes to take effect, please reboot your computer.

Discard Changes and Exit

Select this item to exit from the BIOS setup without making any changes to the system setup configuration, and reboot the computer.

Save Changes and Reset

When you have completed the system configuration changes, select this item to leave the BIOS setup utility and reboot the computer for the new system configuration parameters to take effect.

Save Changes

When you have completed the system configuration changes, select this item to save all changes made. This will not reset (reboot) the system.

Discard Changes

Select this item to discard all the changes and return to the AMI BIOS setup utility. Select Yes and press <Enter> to discard all changes made.

Default Options

Restore Optimized Defaults

Select this item and press <Enter> to load the manufacture default settings which are designed for maximum system performance but not for maximum stability.

Save As User Defaults

Select this item and press <Enter> to save the current BIOS settings as user's default settings for future use.

Restore User Defaults

Select this item and press <Enter> to retrieve the user-defined default settings that were previously saved to be used as current default settings.

Boot Override

This feature allows the user to override the boot priority sequence in the Boot sub-menu and immediately boot the system with another device specified by the user. This is a one-time override.

Appendix A

BIOS POST Error Beep Codes

During the POST (Power-On Self-Test) routines, which are performed upon each system boot, errors may occur.

Non-fatal errors are those which, in most cases, allow the system to continue to boot. These error messages normally appear on the screen.

Fatal errors will not allow the system to continue with bootup. If a fatal error occurs, you should consult with your system manufacturer for possible repairs.

These fatal errors are usually communicated through a series of audible beeps. The numbers on the fatal error list correspond to the number of beeps for the corresponding error.

A-1 BIOS POST Error Beep Codes

BIOS POST Error Beep Codes		
Beep Code/LED	Error Message	Description
1 beep	Refresh	Ready to boot
5 short beeps + 1 long beep	Memory error	No memory detected in the system
5 beeps	No con-in or con-out devices	Con-in includes USB or PS/2 keyboard, PCI or serial console redirection, and IPMI KVM or SOL. Con-out includes the video controller, PCI or serial console redirection, and IPMI SOL.
1 beep per device	Refresh	1 beep for each USB device detected
IPMI Error Codes		
1 Continuous beep	System OH	System overheat

Notes

Appendix B

Software Installation Instructions

B-1 Installing Software Programs

The Supermicro FTP site contains drivers and utilities for your system at <ftp://ftp.supermicro.com>. Some of these must be installed, such as the chipset driver.

After accessing the FTP site, go into the CDR_Images directory and locate the ISO file for your motherboard. Download this file to create a CD/DVD of the drivers and utilities it contains. (You may also use a utility to extract the ISO file if preferred.)

Another option is to go to the Supermicro website at <http://www.supermicro.com/products/>. Find the product page for your motherboard here, where you may download individual drivers and utilities.

After creating a CD/DVD with the ISO files, insert the disk into the CD/DVD drive on your system, and the following screen should appear.



Driver/Tool Installation Display Screen

 **Note 1:** Click the icons showing a hand writing on paper to view the readme files for each item. Click the computer icons to the right of these items to install each item (from top to the bottom) one at a time. **After installing each item, you must reboot the system before moving on to the next item on the list.** The bottom icon with a CD on it allows you to view the entire contents.

Note 2: When making a storage driver diskette by booting into a driver CD, please set the SATA configuration to *Compatible Mode*, and configure the SATA as IDE in the BIOS setup. After making the driver diskette, be sure to change the SATA settings back to your original settings.

B-2 Installing SuperDoctor5

The Supermicro SuperDoctor® 5 is a hardware monitoring program that functions in a command-line or web-based interface in Windows and Linux operating systems. The program monitors system health information, such as CPU temperature, system voltages, system power consumption, and fan speed, and provides alerts via email or the Simple Network Management Protocol (SNMP).

SuperDoctor 5 comes in local and remote management versions and can be used with Nagios to maximize your system monitoring needs. With the SuperDoctor 5 Management Server (SSM Server), you can remotely control the power status and reset chassis intrusion for multiple systems with SuperDoctor 5 or IPMI. SD5 Management Server monitors HTTP, FTP, and SMTP services to optimize the efficiency of your operation.

 **Note:** The default username and password for SuperDoctor 5 is admin/admin.

SuperDoctor 5 Interface Display Screen (Health Information)

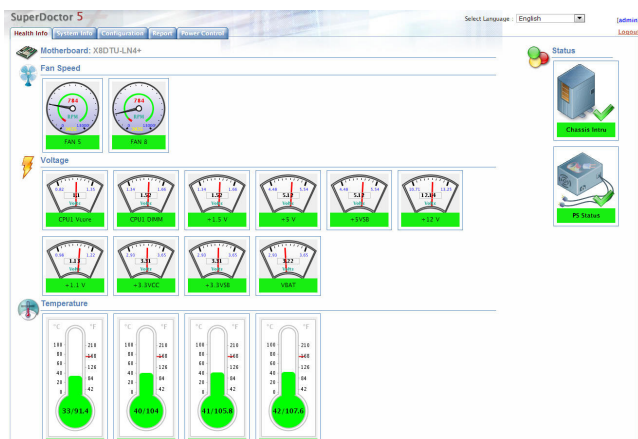

 **Note:** The SuperDoctor 5 program and user's manual can be downloaded from the Supermicro web site at http://www.supermicro.com/products/nfo/sms_sd5.cfm.

B-3 Logging into the BMC (Baseboard Management Controller)

Supermicro ships standard products with a unique password for the BMC user. This password can be found on a label on the motherboard.

When logging in to the BMC for the first time, please use the unique password provided by Supermicro to log in. You can change the unique password to a user name and password of your choice for subsequent logins.

For more information regarding BMC passwords, please visit our website at <http://www.supermicro.com/bmcpassword>.

Appendix C

UEFI BIOS Recovery Instructions

Warning: Do not upgrade the BIOS unless your system has a BIOS-related issue. Flashing the wrong BIOS can cause irreparable damage to the system. In no event shall Supermicro be liable for direct, indirect, special, incidental, or consequential damages arising from a BIOS update. If you need to update the BIOS, do not shut down or reset the system while the BIOS is updating to avoid possible boot failure.

C-1 An Overview to the UEFI BIOS

The Unified Extensible Firmware Interface (UEFI) provides a software-based interface between the operating system and the platform firmware in the pre-boot environment. The UEFI specification supports an architecture-independent mechanism for add-on card initialization to allow the UEFI OS loader, which is stored in the add-on card, to boot the system. The UEFI offers a clean, hands-off control to a computer system at bootup.

C-2 How to Recover the UEFI BIOS Image (-the Main BIOS Block)

A UEFI BIOS flash chip consists of a recovery BIOS block and a main BIOS block (a main BIOS image). The boot block contains critical BIOS codes, including memory detection and recovery codes for the user to flash a new BIOS image if the original main BIOS image is corrupted. When the system power is on, the boot block codes execute first. Once it is completed, the main BIOS code will continue with system initialization and bootup.



Note: Follow the BIOS recovery instructions below for BIOS recovery when the main BIOS boot crashes.

C-3 To Recover the Main BIOS Block Using a USB-Attached Device

This feature allows the user to recover a BIOS image using a USB-attached device without additional utilities used. A USB flash device such as a USB Flash Drive, or a USB CD/DVD ROM/RW device can be used for this purpose. However, a USB Hard Disk drive cannot be used for BIOS recovery at this time.

The file system supported by UEFI is FAT (including FAT12, FAT16, and FAT32) installed on a bootable or non-bootable USB-attached device. However, the BIOS might need several minutes to locate the SUPER.ROM file if the media size becomes too large because it contains too many folders and files.

To perform UEFI BIOS recovery using a USB-attached device, follow the instructions below.

1. Using a different machine, copy the "Super.ROM" binary image file into the disc Root "\\" Directory of a USB device or a writeable CD/DVD.

 **Note:** If you cannot locate the "Super.ROM" file in your driver disk, visit our website at www.supermicro.com to download the BIOS image into a USB flash device and rename it "Super.ROM" for BIOS recovery use.

2. Insert the USB device that contains the new BIOS image ("Super.ROM") into your USB drive and power on the system
3. While powering on the system, please keep pressing <Ctrl> and <Home> simultaneously on your keyboard *until the following screen (or a screen similar to the one below) displays.*

Warning!! Please **stop** pressing the <Ctrl> and <Home> keys immediately when you see the screen (or a similar screen) below; otherwise, it will trigger a system reboot.



 **Note:** On the other hand, if the following screen displays, please load the "Super.ROM" file to the root folder and connect this folder to the system. (You can do so by inserting a USB device that contains the new "Super.ROM" image to your machine for BIOS recovery.)



- After locating the new BIOS binary image, the system will enter the BIOS Recovery menu as shown below.



Note: At this point, you may decide if you want to start with BIOS recovery. If you decide to proceed with BIOS recovery, follow the procedures below.

```

Aptio Setup Utility - Copyright (C) 2010 American Megatrends, Inc.
Main  Advanced  Event Logs  IPMI  Boot  Security  Exit  Recovery

WARNING! BIOS Recovery mode has been detected

Flash Update Parameters
Reset NVRAM                               [Enabled]

▶ Proceed with flash update

Select this to start flash update

+-: Select Screen
TI: Select Item
Enter: Select
+/-: Change Opt.
F1: General Help
F2: Previous Values
F3: Optimized Defaults
F4: Save & Exit
ESC: Exit

Version 2.10.1208, Copyright (C) 2010 American Megatrends, Inc.

```

- When the screen as shown above displays, using the arrow key, select the item "Proceed with flash update" and press the <Enter> key. You will see the progress of BIOS recovery as shown in the screen below.



Note: Do not interrupt the process of BIOS flashing until it is completed.

```

Aptio Setup Utility - Copyright (C) 2010 American Megatrends, Inc.
Recovery

WARNING! System firmware is being updated.
Keyboard is locked.
DO NOT TURN THE POWER OFF !!!
Once firmware update is completed
press any key to reboot the system

Flash update progress           15 %

+-: Select Screen
TI: Select Item
Enter: Select
+/-: Change Opt.
F1: General Help
F2: Previous Values
F3: Optimized Defaults
F4: Save & Exit
ESC: Exit

Version 2.10.1208, Copyright (C) 2010 American Megatrends, Inc.

```

6. After the process of BIOS recovery is completed, press any key to reboot the system.

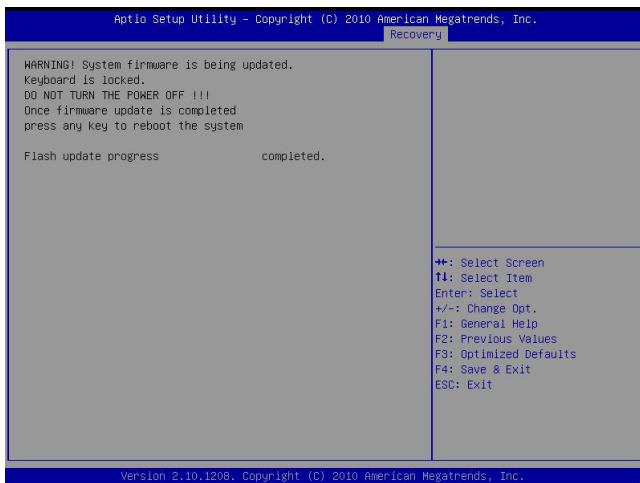

7. Using a different system, extract the BIOS package into a bootable USB flash drive.
8. When a DOS prompt appears, enter FLASH.BAT BIOSName.### at the prompt.



Note: *Do not interrupt this process* until BIOS flashing is completed.

9. After seeing the message that BIOS update is completed, unplug the AC power cable from the power supply to clear the CMOS, and then plug the AC power cable in the power supply again to power on the system.
10. Press continuously to enter the BIOS Setup utility.
11. Press <F3> to load default settings.
12. After loading default settings, press <F4> to save the settings and exit the BIOS Setup utility.

(Disclaimer Continued)

The products sold by Supermicro are not intended for and will not be used in life support systems, medical equipment, nuclear facilities or systems, aircraft, aircraft devices, aircraft/emergency communication devices or other critical systems whose failure to perform be reasonably expected to result in significant injury or loss of life or catastrophic property damage. Accordingly, Supermicro disclaims any and all liability, and should buyer use or sell such products for use in such ultra-hazardous applications, it does so entirely at its own risk. Furthermore, buyer agrees to fully indemnify, defend and hold Supermicro harmless for and against any and all claims, demands, actions, litigation, and proceedings of any kind arising out of or related to such ultra-hazardous use or sale.