

# SUPER<sup>®</sup>

X9SRH-7F  
X9SRH-7TF

## USER'S MANUAL

Revision 1.0a

---

---

The information in this User's Manual has been carefully reviewed and is believed to be accurate. The vendor assumes no responsibility for any inaccuracies that may be contained in this document, makes no commitment to update or to keep current the information in this manual, or to notify any person or organization of the updates. **Please Note: For the most up-to-date version of this manual, please see our web site at [www.supermicro.com](http://www.supermicro.com).**

Super Micro Computer, Inc. ("Supermicro") reserves the right to make changes to the product described in this manual at any time and without notice. This product, including software and documentation, is the property of Supermicro and/or its licensors, and is supplied only under a license. Any use or reproduction of this product is not allowed, except as expressly permitted by the terms of said license.

IN NO EVENT WILL SUPER MICRO COMPUTER, INC. BE LIABLE FOR DIRECT, INDIRECT, SPECIAL, INCIDENTAL, SPECULATIVE OR CONSEQUENTIAL DAMAGES ARISING FROM THE USE OR INABILITY TO USE THIS PRODUCT OR DOCUMENTATION, EVEN IF ADVISED OF THE POSSIBILITY OF SUCH DAMAGES. IN PARTICULAR, SUPER MICRO COMPUTER, INC. SHALL NOT HAVE LIABILITY FOR ANY HARDWARE, SOFTWARE, OR DATA STORED OR USED WITH THE PRODUCT, INCLUDING THE COSTS OF REPAIRING, REPLACING, INTEGRATING, INSTALLING OR RECOVERING SUCH HARDWARE, SOFTWARE, OR DATA.

Any disputes arising between manufacturer and customer shall be governed by the laws of Santa Clara County in the State of California, USA. The State of California, County of Santa Clara shall be the exclusive venue for the resolution of any such disputes. Supermicro's total liability for all claims will not exceed the price paid for the hardware product.

FCC Statement: This equipment has been tested and found to comply with the limits for a Class B digital device pursuant to Part 15 of the FCC Rules. These limits are designed to provide reasonable protection against harmful interference in a residential installation. This equipment generates, uses, and can radiate radio frequency energy and, if not installed and used in accordance with the manufacturer's instruction manual, may cause interference with radio communications. However, there is no guarantee that interference will not occur in a particular installation. If this equipment does cause harmful interference to radio or television reception, which can be determined by turning the equipment off and on, you are encouraged to try to correct the interference by one or more of the following measures:

- Reorient or relocate the receiving antenna.
- Increase the separation between the equipment and the receiver.
- Connect the equipment into an outlet on a circuit different from that to which the receiver is connected.
- Consult the dealer or an experienced radio/television technician for help.

California Best Management Practices Regulations for Perchlorate Materials: This Perchlorate warning applies only to products containing CR (Manganese Dioxide) Lithium coin cells. "Perchlorate Material-special handling may apply. See [www.dtsc.ca.gov/hazardouswaste/perchlorate](http://www.dtsc.ca.gov/hazardouswaste/perchlorate)".

**WARNING: Handling of lead solder materials used in this product may expose you to lead, a chemical known to the State of California to cause birth defects and other reproductive harm.**

---

Manual Revision 1.0a

Release Date: October 8, 2014

Unless you request and receive written permission from Super Micro Computer, Inc., you may not copy any part of this document. Information in this document is subject to change without notice. Other products and companies referred to herein are trademarks or registered trademarks of their respective companies or mark holders.

Copyright © 2014 by Super Micro Computer, Inc. All rights reserved.  
**Printed in the United States of America**

## Preface

This manual is written for system integrators, IT technicians and knowledgeable end users. It provides information for the installation and use of the **SUPER**® X9SRH Motherboard Series motherboard.

### About This Motherboard

The **SUPER**® X9SRH Motherboard Series supports a single Intel® E5-1600/E5-2600 series processor (2011-pin, Socket R). With the Intel® C602J chipset built in, the X9SRH Motherboard series offers top-of-the-line server performance and storage capability. Features such as fourteen (14) SAS/SATA ports, dual 10 Gb LAN ports, support for up to 256GB of memory, and IPMI support make the X9SRH series ideal for high end server platforms.

Please refer to our website (<http://www.supermicro.com/products/>) for processor and memory support updates.

\*This product is intended to be installed and serviced by professional technicians.

### Manual Organization

**Chapter 1** describes the features, specifications and performance of the motherboard, and provides detailed information on the Intel® Patsburg chipset.

**Chapter 2** provides hardware installation instructions. Read this chapter when installing the processor, memory modules and other hardware components into the system. If you encounter any problems, see **Chapter 3**, which describes troubleshooting procedures for video, memory and system setup stored in the CMOS.

**Chapter 4** includes an introduction to the BIOS, and provides detailed information on running the CMOS Setup utility.

**Appendix A** provides BIOS Error Beep Codes.

**Appendix B** lists software program installation instructions.

**Appendix C** contains the UEFI BIOS Recovery instructions.

## Conventions Used in the Manual:

Special attention should be given to the following symbols for proper installation and to prevent damage done to the components or injury to yourself:

**Danger/Caution:** Instructions to be strictly followed to prevent catastrophic system failure or to avoid bodily injury

**Warning:** Critical information to prevent damage to the components or data loss.

**Important:** Important information given to ensure proper system installation.



**Note:** Additional Information given to differentiate various models or provides information for correct system setup.

## Safety Information

The link to the website below contain statements that are industry standard warnings, provided to warn the user of situations which have the potential for bodily injury. Should you have questions or experience difficulty, please contact Supermicro's Technical Support department for assistance. Only certified technicians should attempt to install or configure components.

Read the files completely before installing or configuring components in your Supermicro hardware.

## Contacting Supermicro

### Headquarters

Address: Super Micro Computer, Inc.  
980 Rock Ave.  
San Jose, CA 95131 U.S.A.

Tel: +1 (408) 503-8000

Fax: +1 (408) 503-8008

Email: [marketing@supermicro.com](mailto:marketing@supermicro.com) (General Information)  
[support@supermicro.com](mailto:support@supermicro.com) (Technical Support)

Website: [www.supermicro.com](http://www.supermicro.com)

### Europe

Address: Super Micro Computer B.V.  
Het Sterrenbeeld 28, 5215 ML  
's-Hertogenbosch, The Netherlands

Tel: +31 (0) 73-6400390

Fax: +31 (0) 73-6416525

Email: [sales@supermicro.nl](mailto:sales@supermicro.nl) (General Information)  
[support@supermicro.nl](mailto:support@supermicro.nl) (Technical Support)  
[rma@supermicro.nl](mailto:rma@supermicro.nl) (Customer Support)

Website: [www.supermicro.nl](http://www.supermicro.nl)

### Asia-Pacific

Address: Super Micro Computer, Inc.  
3F, No. 150, Jian 1st Rd.  
Zhonghe Dist., New Taipei City 235  
Taiwan (R.O.C)

Tel: +886-(2) 8226-3990

Fax: +886-(2) 8226-3992

Email: [support@supermicro.com.tw](mailto:support@supermicro.com.tw)

Website: [www.supermicro.com.tw](http://www.supermicro.com.tw)

# Table of Contents

## **Preface**

About This Motherboard.....	iii
Manual Organization .....	iii
Conventions Used in the Manual:.....	iv
Safety Information .....	iv
Contacting Supermicro.....	v

## **Chapter 1 Introduction**

1-1 Overview .....	1-1
Checklist.....	1-1
Motherboard Features.....	1-7
1-2 Chipset Overview .....	1-11
Intel C602J Chipset Series Features.....	1-11
1-3 Special Features .....	1-12
Recovery from AC Power Loss.....	1-12
1-4 PC Health Monitoring.....	1-12
Fan Status Monitor with Firmware Control .....	1-12
Environmental Temperature Control .....	1-12
System Resource Alert .....	1-12
1-5 ACPI Features.....	1-13
Slow Blinking LED for Suspend-State Indicator .....	1-13
1-6 Power Supply .....	1-13
1-7 Super I/O.....	1-14
1-8 Overview of the Nuvoton WPCM450 Controller .....	1-14

## **Chapter 2 Installation**

2-1 Static-Sensitive Devices.....	2-1
Precautions .....	2-1
Unpacking .....	2-1
2-2 Processor and Heatsink Installation.....	2-2
The LGA2011 Socket .....	2-2
Opening the LGA2011 Socket .....	2-3
Installing the LGA2011 Processor .....	2-5
Installing a Passive CPU Heatsink .....	2-7
Removing the Heatsink.....	2-8
2-3 Installing DDR3 Memory.....	2-9
DIMM Installation .....	2-9
Removing Memory Modules .....	2-9
Memory Support.....	2-10

---

	Memory Population Guidelines .....	2-11
2-4	Motherboard Installation.....	2-12
	Tools Needed .....	2-12
	Location of Mounting Holes .....	2-12
	Installing the Motherboard .....	2-13
2-5	Connectors/IO Ports.....	2-14
	Motherboard I/O Backpanel .....	2-14
	ATX PS/2 Keyboard/Mouse Ports .....	2-15
	Universal Serial Bus (USB).....	2-16
	Ethernet Ports .....	2-17
	Serial Ports.....	2-18
	Video Port.....	2-19
	Front Control Panel.....	2-20
	Front Control Panel Pin Definitions.....	2-21
	Power LED .....	2-21
	HDD LED.....	2-21
	Power Fail LED .....	2-21
	NIC1/NIC2 (LAN1/LAN2).....	2-22
	Overheat (OH)/Fan Fail / UID LED .....	2-22
	NMI Button .....	2-23
	Reset Button .....	2-23
	Power Button .....	2-23
2-6	Connecting Cables & Optional Devices.....	2-24
	ATX Main PWR (JPW1) & CPU PWR Connectors (JPW2).....	2-24
	Fan Headers (FAN1~4, FANA) .....	2-25
	Chassis Intrusion (JL1) .....	2-25
	Speaker (JD1) .....	2-26
	Internal Buzzer (SP1).....	2-26
	Wake-On-LAN (JSTBY1).....	2-26
	Power Supply I <sup>2</sup> C (JPI2C1).....	2-27
	DOM PWR Connector (JSD1).....	2-27
	T-SGPIO 1/2 & 6-SGPIO 1/2 Headers.....	2-28
	TPM Header (JTPM1) .....	2-28
	Unit ID Switch (UID SW).....	2-29
	Overheat/Fan Fail LED (JOH1).....	2-29
	System Management Bus (JIPMB1).....	2-30
	Wake-On-Ring.....	2-30
	RAID Key Header (JRK1).....	2-31
2-7	Jumper Settings .....	2-32

---

	Explanation of Jumpers .....	2-32
	LAN Port Enable/Disable (JPL1~2).....	2-32
	CMOS Clear (JBT1).....	2-33
	PCI-E Slot SMB Enable (JI2C1/JI2C2).....	2-33
	VGA Enable (JPG1).....	2-34
	Watch Dog Reset (JWD1).....	2-34
	USB Wake-Up (JPUSB1).....	2-35
	BMC Enable/Disable (JPB1).....	2-35
	ME Recovery (JPME1).....	2-36
	ME Manufacturing Mode (JPME2).....	2-36
	SAS Enable/Disable (JPS1).....	2-36
2-8	Onboard Indicators.....	2-37
	LAN Port LEDs.....	2-37
	IPMI Dedicated LAN LEDs .....	2-37
	Rear Unit ID LED (UID LED) .....	2-38
	IPMI Heartbeat LED (DP3).....	2-38
	Onboard Power LED (DP2).....	2-38
2-9	SATA and SAS Connections.....	2-39
	SATA/SAS Connections .....	2-39

**Chapter 3 Troubleshooting**

3-1	Troubleshooting Procedures .....	3-1
	Before Power On .....	3-1
	No Power .....	3-1
	No Video .....	3-2
	Memory Errors .....	3-2
	When You Lose the System's Setup Configuration.....	3-2
3-2	Technical Support Procedures.....	3-3
3-3	Frequently Asked Questions.....	3-4
3-4	Battery Removal and Installation.....	3-6
	Battery Removal.....	3-6
	Proper Battery Disposal .....	3-6
	Battery Installation.....	3-6
3-5	Returning Merchandise for Service.....	3-7

**Chapter 4 BIOS**

4-1	Introduction.....	4-1
	Starting BIOS Setup Utility.....	4-1
	How to Start the Setup Utility .....	4-2
4-2	Main Setup.....	4-3
	System Overview: The following BIOS information will be displayed:.....	4-3

	System Date/System Time .....	4-3
	Supermicro X9SRH-7F/7TF .....	4-3
	Memory Information .....	4-3
	Total Memory.....	4-3
4-3	Advanced Setup Configurations.....	4-4
	▶BOOT Feature.....	4-4
	Quiet Boot .....	4-4
	AddOn ROM Display Mode.....	4-4
	Bootup Num-Lock.....	4-4
	Wait For 'F1' If Error.....	4-4
	Interrupt 19 Capture .....	4-4
	Retry Boot .....	4-5
	Watch Dog Function.....	4-5
	Power Button Function.....	4-5
	Restore on AC Power Loss.....	4-5
	▶CPU Configuration .....	4-5
	▶Socket 1 CPU Information.....	4-5
	Clock Spread Spectrum .....	4-5
	Hyper Threading.....	4-6
	Active Processor Cores.....	4-6
	Limit CPUID Maximum.....	4-6
	Execute-Disable Bit (if supported by the OS and the CPU).....	4-6
	Intel® AES-NI (If supported by the CPU).....	4-6
	MLC Streamer Prefetcher (if supported by the CPU).....	4-6
	MLC Spatial Prefetch (if supported by the CPU).....	4-6
	DCU Streamer Prefetcher .....	4-6
	DCU IP Prefetcher.....	4-6
	Intel® Virtualization Technology (if supported by the CPU).....	4-7
	▶CPU Power Management Configuration .....	4-7
	Power Technology .....	4-7
	EIST.....	4-7
	Turbo Mode (Available when EIST is set to Enabled).....	4-7
	C1E Support.....	4-7
	CPU C3 Report, CPU C6, CPU C7 Report .....	4-7
	Package C State Limit .....	4-7
	Energy/Performance Bias .....	4-8
	Long duration power limit .....	4-8
	▶Chipset Configuration.....	4-8
	▶North Bridge Configuration.....	4-8

▶Integrated IO Configuration .....	4-8
Intel® VT-d .....	4-8
Intel® I/OAT .....	4-8
DCA Support .....	4-8
MMCFG BASE .....	4-9
IIO 1 PCIe Port Bifurcation Control.....	4-9
CPU1 Slot 3 PCI-E 3.0 x8 (in x16) Link Speed.....	4-9
CPU1 Slot 6 PCI-E 3.0 x16 Link Speed .....	4-9
▶DIMM Configuration.....	4-9
Memory Configuration .....	4-9
▶DIMM Information .....	4-9
Memory Mode .....	4-9
DRAM RAPL Mode .....	4-9
DDR Speed .....	4-10
Channel Interleaving .....	4-10
Rank Interleaving .....	4-10
Patrol Scrub.....	4-10
Demand Scrub .....	4-10
Data Scrambling .....	4-10
Device Tagging .....	4-10
Thermal Throttling .....	4-11
▶South Bridge Configuration .....	4-11
All USB Devices .....	4-11
EHCI Controller 1 / EHCI Controller 2 .....	4-11
Legacy USB Support.....	4-11
Port 60/64 Emulation.....	4-11
EHCI Hand-Off .....	4-11
▶SATA Configuration .....	4-11
SATA Port0~Port5 .....	4-11
SATA Mode.....	4-12
IDE Mode .....	4-12
Serial-ATA Controller 0~1 .....	4-12
AHCI Mode.....	4-12
Aggressive Link Power Management.....	4-12
Port 0~5 Hot Plug.....	4-12
Port 0~5 Staggered Spin Up.....	4-12
RAID Mode.....	4-12
SATA RAID Option ROM/UEFI Driver.....	4-12
Port 0~5 Hot Plug.....	4-12

▶PCIe/PCI/PnP Configuration .....	4-13
Launch Storage OpROM Policy .....	4-13
PCI Latency Timer .....	4-13
PERR# Generation .....	4-13
SERR# Generation .....	4-13
Maximum Payload .....	4-13
Maximum Read Request .....	4-13
ASPM Support .....	4-13
Above 4G Decoding .....	4-13
Slot1 PCI 33MHZ OPROM	
Slot2 PCI 33MHZ OPROM	
CPU1 Slot3 PCI-E 3.0 x8 (in x16) OPROM	
Slot4 PCI 33MHz OPROM (X9SRH-7F only)	
PCH Slot5 PCI-E 2.0 x4 OPROM	
CPU1 Slot6 PCI-E 3.0 x16 OPROM .....	4-14
Onboard LAN Option ROM Select .....	4-14
Load Onboard LAN1 Option ROM / Load Onboard LAN2 Option ROM .....	4-14
VGA Priority .....	4-14
Network Stack .....	4-14
IPv4 PXE Support (Available when Network Stack is set to Enabled)....	4-14
▶Super IO Device Configuration .....	4-14
▶Serial Port 1 Configuration / Serial Port 2 Configuration .....	4-14
Serial Port 1 / Serial Port 2 .....	4-14
Serial Port 1 Settings / Serial Port 2 Settings .....	4-14
▶Serial Port Console Redirection .....	4-15
▶ACPI Settings .....	4-16
High Precision Event Timer .....	4-16
▶Trusted Computing .....	4-17
▶Intel TXT(LT-SX) Configuration .....	4-17
CPU/Chipset TXT Feature .....	4-17
TXT Support .....	4-17
Intel TXT(LT-SX) Dependencies .....	4-17
▶ME Subsystem .....	4-18
▶iSCSI Configuration .....	4-18
iSCSI Initiator Name .....	4-18
Add an Attempt .....	4-18
Delete Attempts .....	4-19
Change Attempt Order .....	4-19
Intel(R) Intel Ethernet Controller X540-AT2/	
Intel(R) Intel Ethernet Controller X540-AT2 .....	4-19
NIC Configuration .....	4-19

	Link Speed .....	4-19
	Wake On LAN .....	4-19
	Blink LEDs (Range 0-15 seconds).....	4-19
	Port Configuration Information .....	4-19
4-4	Event Logs .....	4-20
	▶Change SmbIOS Event Log Settings .....	4-20
	Smbios Event Log .....	4-20
	Runtime Error Logging Support .....	4-20
	Memory Correction Error Threshold.....	4-20
	PCI Error Logging Support.....	4-20
	Erase Event Log.....	4-20
	When Log is Full .....	4-20
	Log System Boot Event .....	4-21
	MECI.....	4-21
	METW.....	4-21
	View SmbIOS Event Log .....	4-21
4-5	IPMI .....	4-22
	▶System Event Log .....	4-22
	When SEL is Full.....	4-22
	▶BMC Network Configuration .....	4-22
	Update IPMI LAN Configuration.....	4-22
	Configuration Address Source .....	4-23
4-6	Boot Settings.....	4-24
	Set Boot Priority .....	4-24
	1st Boot Device, 2nd Boot Device, 3rd Boot Device, etc. ....	4-24
	▶Add Boot Option.....	4-24
	Network Devices, USB Device BBS Priorities, Hard Disk Drives.....	4-24
4-7	Security Settings .....	4-25
	Password Check .....	4-25
	Administrator Password .....	4-25
4-8	Save & Exit .....	4-26
	Discard Changes and Exit .....	4-26
	Save Changes and Reset .....	4-26
	Save Changes.....	4-26
	Discard Changes.....	4-26
	Restore Optimized Defaults .....	4-27
	Save As User Defaults .....	4-27
	Restore User Defaults.....	4-27
	Boot Override .....	4-27

---

---

**Appendix A BIOS Error Beep Codes**

A-1	BIOS Error Beep Codes .....	A-1
-----	-----------------------------	-----

**Appendix B Software Installation Instructions**

B-1	Installing Drivers.....	B-1
-----	-------------------------	-----

B-2	Configuring SuperDoctor® III.....	B-2
-----	-----------------------------------	-----

**Appendix C UEFI BIOS Recovery Instructions**

	An Overview to the UEFI BIOS.....	C-1
--	-----------------------------------	-----

	How to Recover the UEFI BIOS Image (the Main BIOS Block).....	C-1
--	---	-----

	To Recover the Main BIOS Block Using a USB-Attached Device.....	C-1
--	---	-----

## **Notes**

# Chapter 1

## Introduction

### 1-1 Overview

#### Checklist

Congratulations on purchasing your computer motherboard from an acknowledged leader in the industry. Supermicro boards are designed with the utmost attention to detail to provide you with the highest standards in quality and performance.

Please check that the following items have all been included with your motherboard. If anything listed here is damaged or missing, contact your retailer.

The following items are included in the retail box.

- One (1) Supermicro Mainboard
- Six (6) SATA cables
- One (1) I/O shield



**Note:** For your system to work properly, please follow the links below to download all necessary drivers/utilities and the user's manual for your motherboard.

- SMCI product manuals: <http://www.supermicro.com/support/manuals/>
- Product Drivers and utilities: <ftp://ftp.supermicro.com/>



**Warning:** For safety considerations, please refer to the complete list of safety warnings posted on the Supermicro website at [http://www.supermicro.com/about/policies/safety\\_information.cfm](http://www.supermicro.com/about/policies/safety_information.cfm).

If you have any questions, please contact our support team at [support@supermicro.com](mailto:support@supermicro.com).

SUPER X9SRH-7F Motherboard Series Image

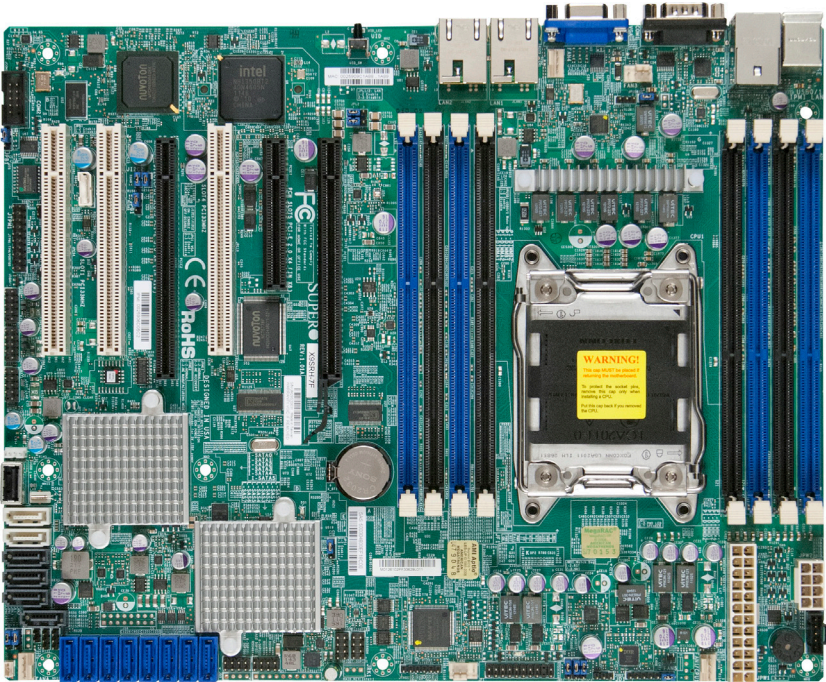

**Note:** All graphics shown in this manual were based upon the latest PCB Revision available at the time of publishing of the manual. The motherboard you've received may or may not look exactly the same as the graphics shown in this manual.

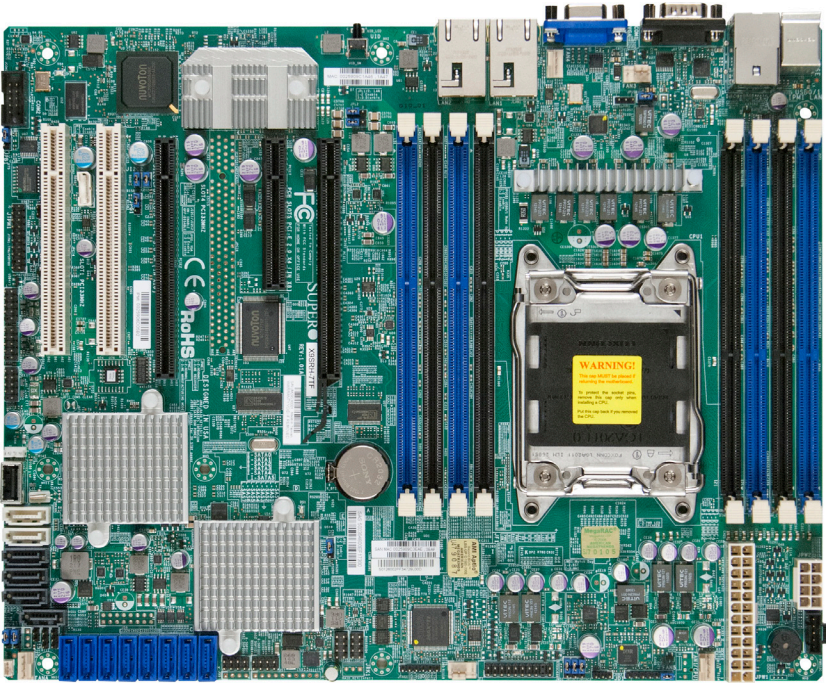
**SUPER** X9SRH-7TF Motherboard Series Image

**Note:** All graphics shown in this manual were based upon the latest PCB Revision available at the time of publishing of the manual. The motherboard you've received may or may not look exactly the same as the graphics shown in this manual.



## X9SRH Motherboard Series Quick Reference

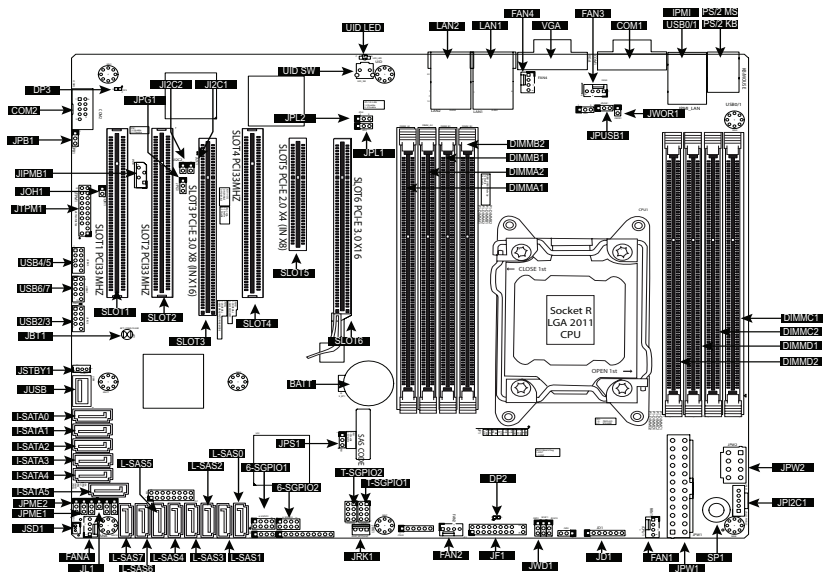

## X9SRH Motherboard Series Jumpers

Jumper	Description	Default
JPB1	BMC Enable (for "F" models only)	Pins 1-2 (Enabled)
JWD1	Watch Dog Reset	Pins 1-2 (Reset)
JUSB1	USB Power Select	Pins 1-2 (Dual Power)
JPG1	Onboard VGA Enable	Pins 1-2 (Enabled)
JSTBY1	Wake on LAN Enable	Pins 1-3 (Enabled)
J12C1/J12C2	SMB to PCI-E Slots	On (Enabled)
JPL1/JPL2	LAN1/LAN2 Enable	Pins 1-2 (Enabled)
JPME1	ME Recovery	Pins 1-2 (Normal)
JPME2	Intel ME Mode Select	Pins 1-2 (Normal)
JBT1	CMOS Clear	See Chapter 2

## X9SRH Motherboard Series LED Indicators

LED	Description	Color/State	Status
DP3	IPMI Heartbeat	Green/Blinking	BMC/IPMI Normal
UID LED	UID (Unit ID) LED	Blue: Solid On	UID: On
DP2	Power On LED	Green: Solid On	System is On

<b>X9SRH Motherboard Series Headers/Connectors</b>	
<b>Connector</b>	<b>Description</b>
COM1, COM2	COM1 Backpanel Serial Port, COM2 Serial Port Header
JIPMB1	System Management Bus Header for the IPMI Slot
JTPM1	Trusted Platform Module (TPM) Header
USB 2/3, 4/5, 6/7	Front Accessible USB Connections (via 3 Headers)
USB 0, USB 1	Backpanel USB Ports 0, 1
JOH1	Overheat LED/Fan Fail
JWOR	Wake-On-Ring Header
6-SGPIO1, 6-SGPIO2	Serial General Purpose I/O Headers for SAS
JUSB	Internal Type A USB port
L-SAS0-L-SAS7	Internal Serial-Attached SCSI (SAS2, 6Gb/s) ports via LSI 2308 chipset
FAN A, FAN 1~4	Internal Fan headers (Fan 1~4), I/O Fan (Fan A)
I-SATA 0/1	SATA 3.0 ports (6Gb/s) via PCH
I-SATA 2~5	SATA 2.0 ports (3Gb/s) via PCH
T-SGPIO1, T-SGPIO2	Serial Link General Purpose I/O 1/2 Headers (5V Gen1/Gen 2)
JF1	Front Panel Control Header
JD1	Power LED / Speaker Header (Pins 4~7: External Speaker)
JL1	Chassis Intrusion Header
JPI2C1	Power Supply SMBus I2C Header
JPW2	8-pin Secondary Power Connector
JPW1	24-pin Main ATX Power Connector
PS/2 MS	Backpanel PS/2 Mouse Port
PS/2 KB	Backpanel PS/2 Keyboard Port
IPMI	IPMI LAN Port
VGA	Backpanel VGA Port
LAN1, LAN2	Backpanel Gbit LAN Ports 1, 2 (10Gbit LAN for X9SRH-7TF)
UID SW	Unit ID Switch
JSD1	Disk On Module (DOM) Power
JRK1	RAIDkey Header
SPK1	Internal Speaker/Buzzer
BATT	Internal Battery
SLOT1/SLOT2/SLOT4	PCI-32 Expansion Slot (SLOT4 is available on the X9SRH-7F Only)
SLOT3	PCI-Express 3.0 x8 (in x16) Slot
SLOT5	PCI-Express 2.0 x4 (in x8) Slot
SLOT6	PCI-Express 3.0 x16 Slot
DIMMA1~DIMMD2	DDR3 UDIMM Memory Slots

## Motherboard Features

<b>CPU</b>	Single Intel® Xeon® E5-1600/E5-2600 series processor, up to 8 cores, 135W (LGA 2011 pin, Socket-R)	
<b>Memory</b>	Eight (8) DIMM slots support up to 256GB of DDR3, ECC RDIMM memory or 64GB of DDR3 Unbuffered, non-ECC UDIMM memory, up to 1600MHz.	
	Supports dual-channel memory bus	
	<b>DIMM sizes</b>	
	UDIMM	1GB, 2GB, 4GB, 8GB
	RDIMM/LRDIMM	2GB, 4GB, 8GB, 16GB, 32GB
<b>Chipset</b>	Intel® C602J	
<b>Expansion Slots</b>	<b>X9SRH-7F Series Only</b>	
	Three (3) PCI-32 Slots	
	One (1) PCI-Express 3.0 x16 Slot	
	One (1) PCI-Express 3.0 x8 in x16 Slot	
	One (1) PCI-Express 2.0 x4 in x8 Slot	
	<b>X9SRH-7TF Series</b>	
	Two (2) PCI-32 Slots	
	One (1) PCI-Express 3.0 x16 Slot	
	One (1) PCI-Express 3.0 x8 in x16 Slot	
	One (1) PCI-Express 2.0 x4 in x8 Slot	
<b>Integrated Graphics</b>	Matrox® G200eW (on BMC controller)	
<b>Network Connections</b>	X9SRH-7F: Two (2) Gbit LAN Ports (1x Intel i350)	
	X9SRH-7TF: Two (2) 10Gbit LAN Ports (1x Intel x540)	
<b>I/O Devices</b>	<b>SAS2/SATA Connections</b>	
	SAS2 Ports, 6Gb/s	Eight (8)
	RAID Support	RAID 0, 1, 10, 5 (option)
	SATA 3.0 Ports, 6Gb/s	Two (2)
	RAID Support	RAID 0, 1, 5, 10
	SATA 2.0 Ports, 3Gb/s	Four (4)
	RAID Support	RAID 0, 1, 5, 10
	<b>Integrated IPMI 2.0</b>	
	IPMI 2.0 supported by the WPCM450 Server BMC	
	<b>USB Devices</b>	
	Two (2) USB ports on the rear I/O panel	
	Six (6) USB headers for front access	
	One (1) Type A internal connector	

	<p><b>Keyboard/Mouse</b></p> <p>One (1) each PS/2 KB and PS/2 Mouse port</p> <p><b>Serial (COM) Ports</b></p> <p>Two (2) Fast UART 16550 connections: one 9-pin RS-232 port (Backpanel COM1 port) and one header (COM2)</p> <p><b>Super I/O</b></p> <p>Winbond Super I/O NCT6776F</p>
<b>BIOS</b>	<p>64 Mb SPI AMI BIOS® SM Flash BIOS</p> <p>Plug &amp; Play, APM 1.2, DMI 2.3, PCI 2.2, ACPI 1.0/2.0, RTC, HW Virus protection, USB Keyboard, SMBIOS 2.3</p>
<b>Power Configuration</b>	<p>ACPI/ACPM Power Management</p> <p>Wake On LAN (WOL) Header</p> <p>Keyboard Wake-up from Soft-Off</p> <p>CPU Fan Auto-off in Sleep Mode</p> <p>Power-on mode for AC power recovery</p>
<b>PC Health Monitoring</b>	<p><b>CPU Monitoring</b></p> <p>Onboard voltage monitors for CPU core, 1.8V, +3.3V, +5V, +/-12V, 3.3V Stby, +5V Stby, VBAT, HT, Memory, Chipset</p> <p>CPU 5-phase switching voltage regulator</p> <p>CPU/System overheat LED and control</p> <p>CPU Thermal Trip support</p> <p>CPU &amp; Chassis Environment</p> <p><b>Fan Control</b></p> <p>Fan status monitoring with firmware 4-pin (Pulse Width Modulation) fan speed control</p> <p>Low noise fan speed control</p>
<b>System Management</b>	<p>PECI (Platform Environment Configuration Interface) 2.0 support</p> <p>System resource alert via SuperDoctor® III</p> <p>SuperDoctor® III (available via download), Watchdog, NMI</p> <p>Chassis Intrusion header and detection</p> <p>Intel Node Manager Support</p>
<b>CD Utilities</b>	<p>BIOS flash upgrade utility</p> <p>Drivers and software for Intel® C602J chipset utilities</p>
<b>Other</b>	<p>ROHS 6/6 (Full Compliance, Lead Free)</p>
<b>Dimensions</b>	<p>ATX form factor (12" x 9.6")</p>



**Note:** For IPMI Configuration Instructions, please refer to the Embedded IPMI Configuration User's Guide available @ <http://www.supermicro.com/support/manuals/>.

<b>X9SRH Motherboard Features Comparison</b>								
Model	SAS	SATA (2.0/3.0)	IPMI	LAN	PCI-32 Slots	PCI-E 3.0 x16	PCI-E 3.0 x8 on x16	PCI-E 2.0 x4 on x8
X9SRH-7F	8 (6Gb/s)	4/2	Yes	1Gb	3	1	1	1
X9SRH-7TF	8 (6Gb/s)	4/2	Yes	10Gb	2	1	1	1

X9SRH Motherboard Series Block Diagram

X9SRH

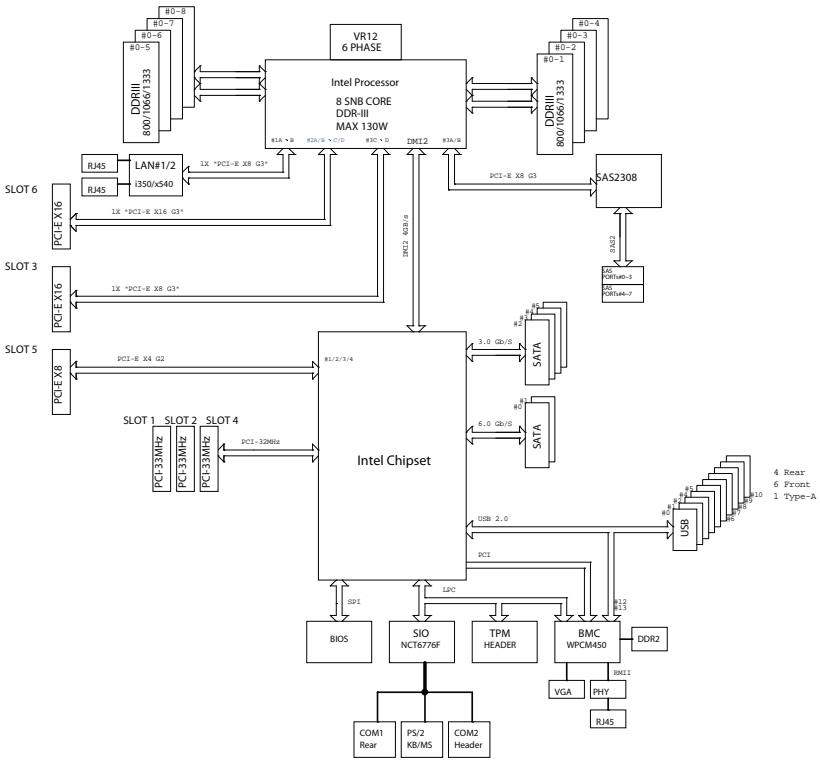

System Block Diagram



**Note:** This is a general block diagram and may not exactly represent the features on your motherboard. See the Motherboard Features pages for the actual specifications of each motherboard.

## 1-2 Chipset Overview

The Intel® C602J is a single chip solution that is designed for dedicated servers and workstations. It supports high-speed SAS, SATA and advanced requirements for Intel® Xeon platforms.

### **Intel C602J Chipset Series Features**

- Direct Media Interface (up 20 Gb/s each direction, Full Duplex)
- Intel® Matrix Storage Technology and Intel Rapid Storage Technology
- Intel® I/O Virtualization (VT-d) Support
- Intel® Trusted Execution Technology Support
- PCI Express 2.0 Interface (up to 5.0 GT/s)
- PCI Express 3.0 Interface (up to 8.0 GT/s)
- 4 SATA 2.0 ports, 2 SATA 3.0 ports (up to 6 Gb/s)
- Advanced Host Controller Interface (AHCI)

## 1-3 Special Features

### Recovery from AC Power Loss

Basic I/O System (BIOS) provides a setting for you to determine how the system will respond when AC power is lost and then restored to the system. You can choose for the system to remain powered off (in which case you must press the power switch to turn it back on), or for it to automatically return to a power-on state. See the Advanced BIOS Setup section to change this setting. The default setting is **Last State**.

## 1-4 PC Health Monitoring

This section describes the PC health monitoring features of the board. All have an onboard System Hardware Monitoring chip that supports PC health monitoring. An onboard voltage monitor will scan these onboard voltages continuously: CPU Vcore, 12V Scale, DIMM, 1.5V, 3.3V Vcc(V), Vcc5V, CPU VTT, 3.3VSB, and Battery Voltage. Once a voltage becomes unstable, a warning is given, or an error message is sent to the screen. The user can adjust the voltage thresholds to define the sensitivity of the voltage monitor.

### Fan Status Monitor with Firmware Control

PC health monitoring in the BIOS can check the RPM status of the cooling fans. The onboard CPU and chassis fans are controlled by Thermal Management via BIOS (under the Hardware Monitoring section in the Advanced Setting).

### Environmental Temperature Control

The thermal control sensor monitors the CPU temperature in real time and will turn on the thermal control fan whenever the CPU temperature exceeds a user-defined threshold. The overheat circuitry runs independently from the CPU. Once the thermal sensor detects that the CPU temperature is too high, it will automatically turn on the thermal fans to prevent the CPU from overheating. The onboard chassis thermal circuitry can monitor the overall system temperature and alert the user when the chassis temperature is too high.



**Note:** To avoid possible system overheating, please be sure to provide adequate airflow to your system.

### System Resource Alert

This feature is available when the system is used with SuperDoctor<sup>®</sup> III in the

Windows OS environment or used with SuperDoctor II in Linux. SuperDoctor is used to notify the user of certain system events. For example, you can also configure SuperDoctor to provide you with warnings when the system temperature, CPU temperatures, voltages and fan speeds go beyond predefined thresholds.

## 1-5 ACPI Features

ACPI stands for Advanced Configuration and Power Interface. The ACPI specification defines a flexible and abstract hardware interface that provides a standard way to integrate power management features throughout a PC system, including its hardware, operating system and application software. This enables the system to automatically turn on and off peripherals such as CD-ROMs, network cards, hard disk drives and printers.

In addition to enabling operating system-directed power management, ACPI also provides a generic system event mechanism for Plug and Play, and an operating system-independent interface for configuration control. ACPI leverages the Plug and Play BIOS data structures, while providing a processor architecture-independent implementation that is compatible with Windows XP, Windows Vista and Windows 2008 Operating Systems.

### **Slow Blinking LED for Suspend-State Indicator**

When the CPU goes into a suspend state, the chassis power LED will start to blink to indicate that the CPU is in suspend mode. When the user presses any key, the CPU will "wake up", and the LED will automatically stop blinking and remain on.

## 1-6 Power Supply

As with all computer products, a stable power source is necessary for proper and reliable operation. It is even more important for processors that have high CPU clock rates.

This motherboard accommodates 24-pin ATX power supplies. Although most power supplies generally meet the specifications required by the CPU, some are inadequate. In addition, the 12V 8-pin power connector located at JPW2 is also required to ensure adequate power supply to the system. Also your power supply must supply 1.5A for the Ethernet ports.

It is strongly recommended that you use a high quality power supply that meets ATX power supply Specification 2.02 or above. It must also be SSI compliant. (For more information, please refer to the web site at <http://www.ssiforum.org/>). Additionally, in areas where noisy power transmission is present, you may choose to install a line

filter to shield the computer from noise. It is recommended that you also install a power surge protector to help avoid problems caused by power surges.

## 1-7 Super I/O

The Super I/O supports two high-speed, 16550 compatible serial communication ports (UARTs). Each UART includes a 16-byte send/receive FIFO, a programmable baud rate generator, complete modem control capability and a processor interrupt system. Both UARTs provide legacy speed with baud rate of up to 115.2 Kbps as well as an advanced speed with baud rates of 250 K, 500 K, or 1 Mb/s, which support higher speed modems.

The Super I/O provides functions that comply with ACPI (Advanced Configuration and Power Interface), which includes support of legacy and ACPI power management through an SMI or SCI function pin. It also features auto power management to reduce power consumption.

## 1-8 Overview of the Nuvoton WPCM450 Controller

The Nuvoton WPCM450R Controller is a Baseboard Management Controller (BMC) that supports 2D/VGA-compatible Graphics cores, Virtual Media, and Keyboard/Video/Mouse Redirection (KVMR) modules. With blade-oriented Super I/O capability built in, the WPCM450R Controller is ideal for legacy-reduced server platforms.

The WPCM450R interfaces with a host system via PCI interface to communicate with the Graphics core. It supports USB 2.0 and 1.1 for remote keyboard/mouse/virtual media emulation. It also provides LPC interface to control Super IO functions. The WPCM450R is connected to the network via an external Ethernet PHY module.

The WPCM450R communicates with onboard components via six SMBus interfaces, fan control, and Platform Environment Control Interface (PECI) buses.



**Note:** For more information on IPMI configuration, please refer to the Embedded IPMI User's Guide posted on our Website @ <http://www.supermicro.com/support/manuals/>.

## Chapter 2

### Installation

#### 2-1 Static-Sensitive Devices

Electrostatic-Discharge (ESD) can damage electronic components. To avoid damaging your system board, it is important to handle it very carefully. The following measures are generally sufficient to protect your equipment from ESD.

##### **Precautions**

- Use a grounded wrist strap designed to prevent static discharge.
- Touch a grounded metal object before removing the board from the antistatic bag.
- Handle the board by its edges only; do not touch its components, peripheral chips, memory modules or gold contacts.
- When handling chips or modules, avoid touching their pins.
- Put the motherboard and peripherals back into their antistatic bags when not in use.
- For grounding purposes, make sure your computer chassis provides excellent conductivity between the power supply, the case, the mounting fasteners and the motherboard.
- Use only the correct type of onboard CMOS battery. Do not install the onboard battery upside down to avoid possible explosion.
- Please read the Standardized Warning Statements at Supermicro's website: [http://www.supermicro.com/about/policies/safety\\_information.cfm](http://www.supermicro.com/about/policies/safety_information.cfm).

##### **Unpacking**

The motherboard is shipped in antistatic packaging to avoid static damage. When unpacking the board, make sure that the person handling it is static protected.

## 2-2 Processor and Heatsink Installation

**Warning:** When handling the processor package, avoid placing direct pressure on the label area.



**Notes:**

Always connect the power cable last, and always remove it before adding, removing or changing any hardware components. Make sure that you install the processor into the CPU socket before you install the CPU heatsink.

If you buy a CPU separately, make sure that you use an Intel-certified multi-directional heatsink only.

Make sure to install the system board into the chassis before you install the CPU heatsink.

When receiving a server board without a processor pre-installed, make sure that the plastic CPU socket cap is in place and none of the socket pins are bent; otherwise, contact your retailer immediately.

Refer to the Supermicro website for updates on CPU support.

Please proceed to the following pages for instructions on processor and heatsink installation.

### The LGA2011 Socket

Currently, there are two kinds of LGA2011 socket mounted on Supermicro motherboards, a 'regular' and a 'narrow' sized socket. Though they may look slightly different from one another, however the labeling, operation of the hardware, mounting of the CPU are similar on both types. The 'narrow' type socket is installed on this motherboard (X9SRH series)

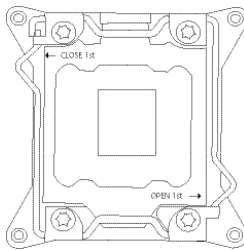

Regular LGA2011 Socket

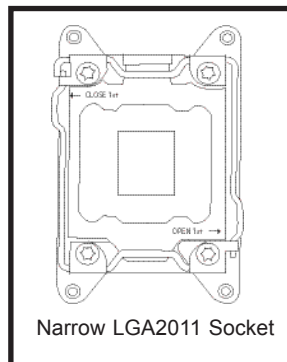

Narrow LGA2011 Socket

## Opening the LGA2011 Socket

The instructions on the following pages will show the 'regular' type socket. However, they also apply to the 'narrow' type as well. The drawings are provided for illustration purposes only.

1. Before opening the LGA2011 socket, remove the black 'IMPORTANT!' plastic protective cap using your fingers and save it for future use.

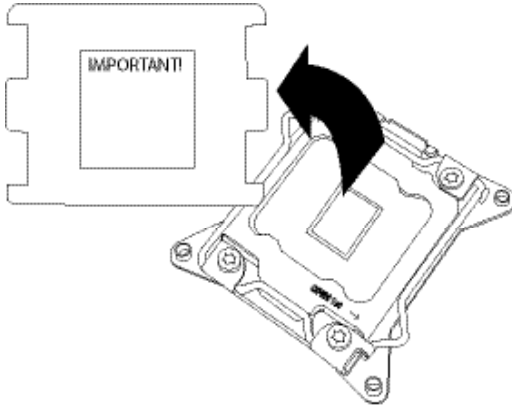

2. There are two load levers on the LGA2011 socket. To open the socket cover, first press and release the load lever labeled 'Open 1st'.

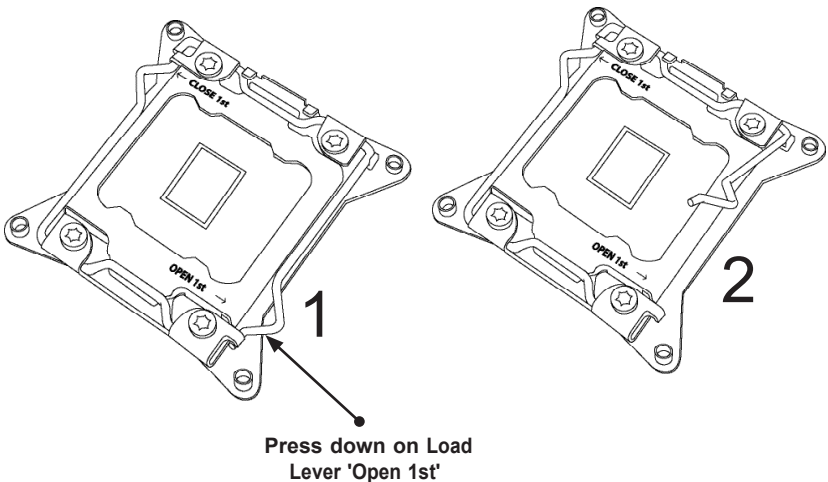

1. Press the second load lever labeled 'Close 1st' to release the load plate which covers the CPU socket from its locking position.

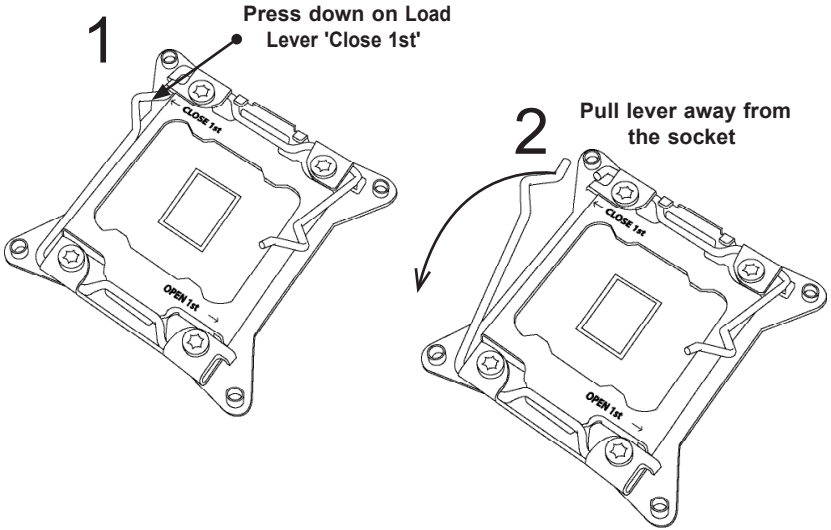

2. With the 'Close 1st' lever fully retracted, gently push down on the 'Open 1st' lever to open the load plate. Lift the load plate to open it completely.

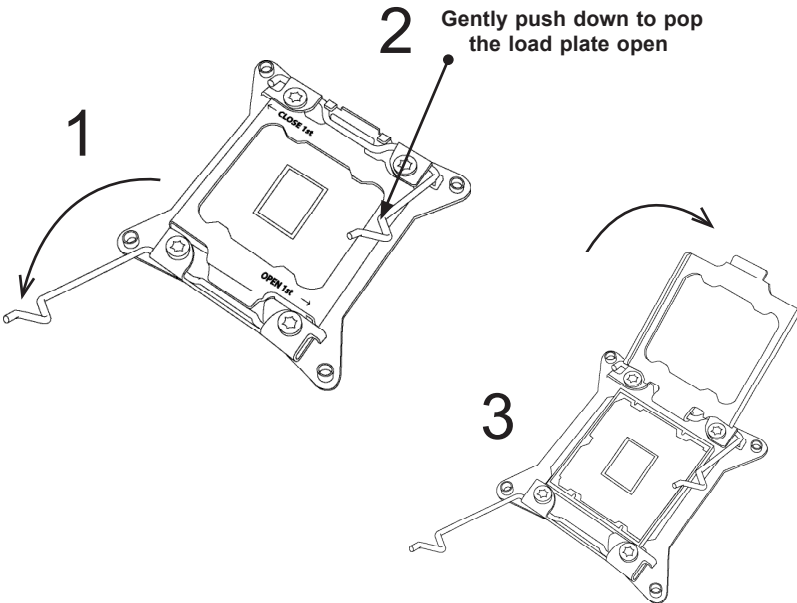

## Installing the LGA2011 Processor

1. Use your thumb and index finger to hold the CPU on its edges. Align the CPU keys (semi-circle cutouts) against the socket keys.

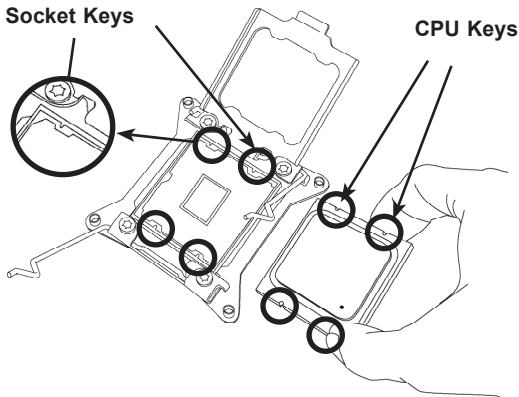

2. Once it is aligned, carefully lower the CPU straight down into the socket. (Do not drop the CPU on the socket. Do not move the CPU horizontally or vertically.)

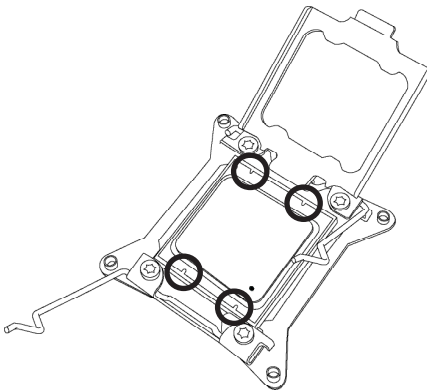

**Warning:** You can only install the CPU inside the socket in one direction. Make sure that it is properly inserted into the CPU socket before closing the load plate. If it doesn't close properly, do not force it as it may damage your CPU. Instead, open the load plate again and double-check that the CPU is aligned properly.

1. Do not rub the CPU against the surface or against any pins of the socket to avoid damaging the CPU or the socket.)
2. With the CPU inside the socket, inspect the four corners of the CPU to make sure that the CPU is properly installed.
3. To close and lock the socket, close the load plate with the CPU. Lock the 'Close 1st' lever first, then lock the 'Open 1st' lever second. Use your thumb to gently push the load levers down to the lever locks.

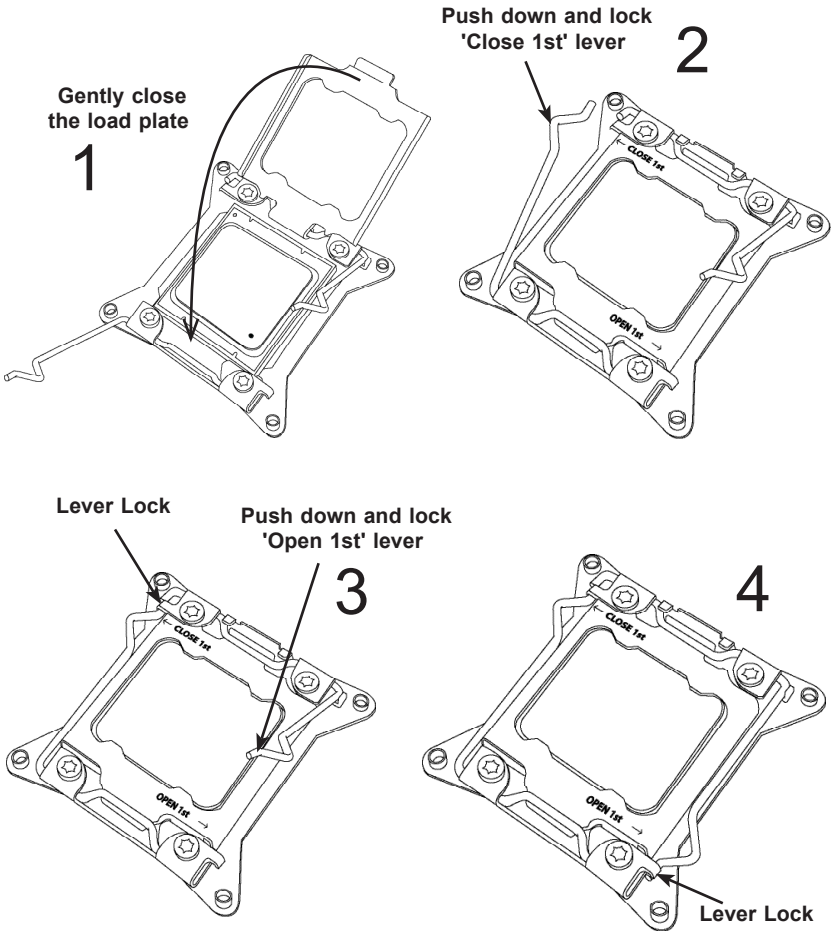

## Installing a Passive CPU Heatsink

1. Do not apply any thermal grease to the heatsink or the CPU die -- the required amount has already been applied.
2. Place the heatsink on top of the CPU so that the four mounting holes are aligned with those on the Motherboard's and the Heatsink Bracket underneath.
3. Screw in two diagonal screws (i.e., the #1 and the #2 screws) until just snug (do not over-tighten the screws to avoid possible damage to the CPU.)
4. Finish the installation by fully tightening all four screws.

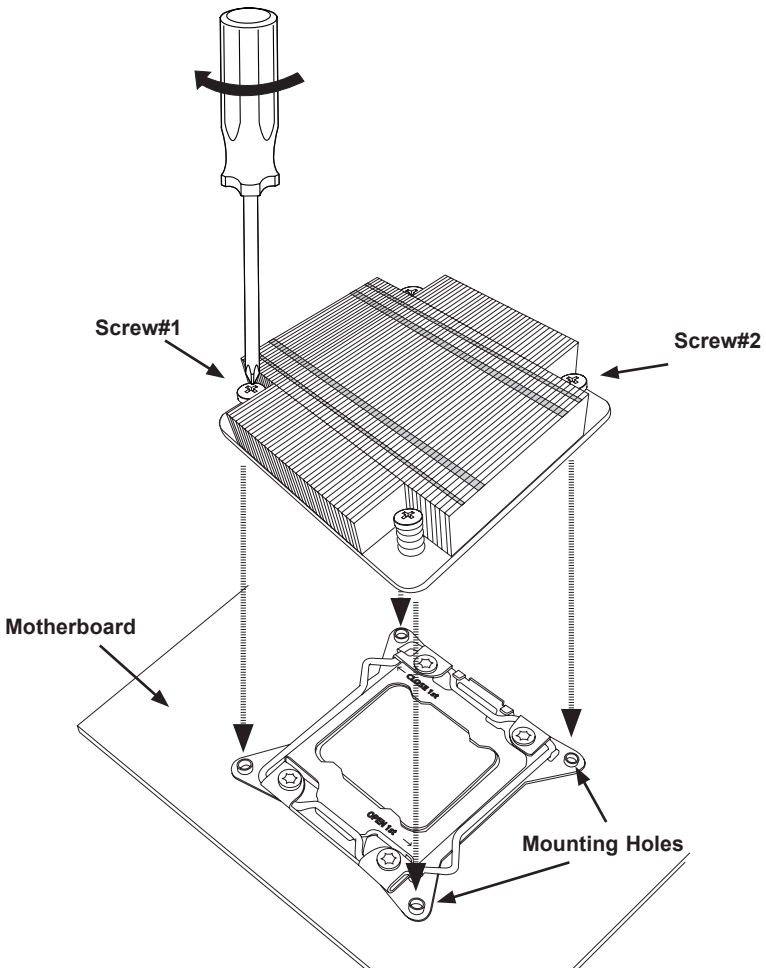

## Removing the Heatsink

**Warning:** We do not recommend that the CPU or the heatsink be removed. However, if you do need to uninstall the heatsink, please follow the instructions below to uninstall the heatsink to prevent damage done to the CPU or the CPU socket.

1. Unscrew the heatsink screws from the motherboard in the sequence as shown in the illustration below.
2. Gently wriggle the heatsink to loosen it from the CPU. (Do not use excessive force when wriggling the heatsink!!)
3. Once the heatsink is loosened, remove the heatsink from the CPU socket.
4. Clean the surface of the CPU and the heatsink, removing the used thermal grease. Re-apply the proper amount of thermal grease on the surface before re-installing the CPU and the heatsink.

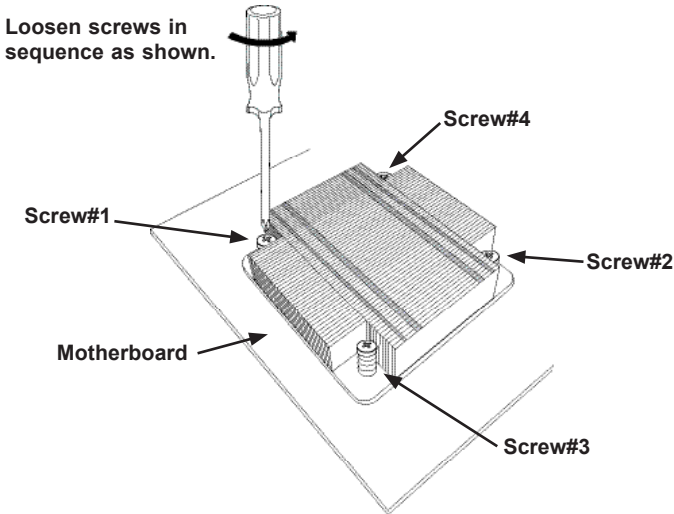

## 2-3 Installing DDR3 Memory



**Note:** Check the Supermicro website for recommended memory modules.

### CAUTION

Exercise extreme care when installing or removing DIMM modules to prevent any possible damage.

### DIMM Installation

1. Insert the desired number of DIMMs into the memory slots, starting with DIMM1A (see the next page for the location). For best performance, please use the memory modules of the same type and speed in the same bank.
2. Push the release tabs outwards on both ends of the DIMM slot to unlock it.
3. Align the key of the DIMM module with the receptive point on the memory slot.
4. Align the notches on both ends of the module against the receptive points on the ends of the slot.
5. Use two thumbs together to press the notches on both ends of the module straight down into the slot until the module snaps into place.
6. Press the release tabs to the lock positions to secure the DIMM module into the slot.

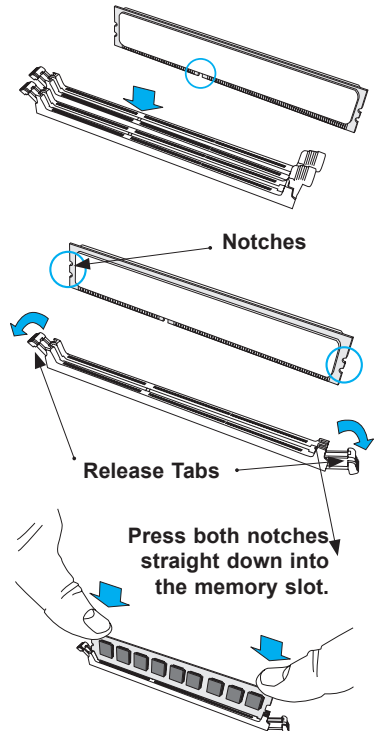
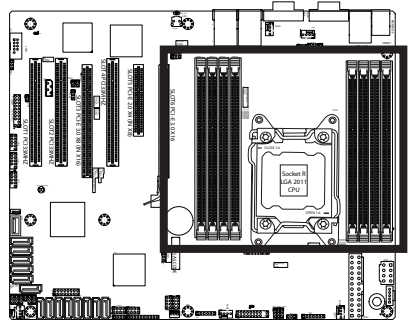

### Removing Memory Modules

Reverse the steps above to remove the DIMM modules from the motherboard.

## Memory Support

The X9SRH motherboard series supports up to 256GB of 1600/1066/1333/1600 MHz ECC/Non-ECC DDR3 DIMMs in eight (8) memory slots (UDIMM/RDIMM). Populating these DIMM modules with a pair of memory modules of the same type and same size will result in interleaved memory, which will improve memory performance. Please refer to the table below:

Edge of the motherboard 

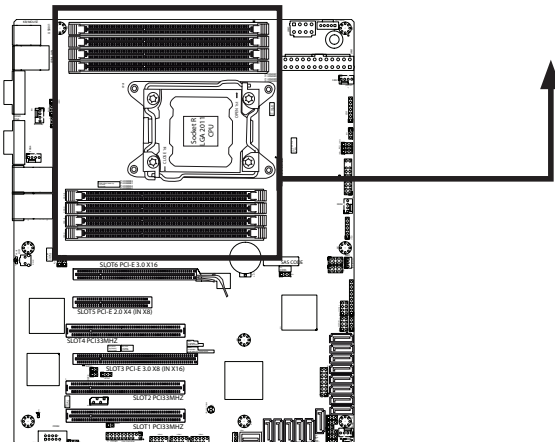
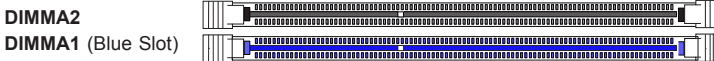
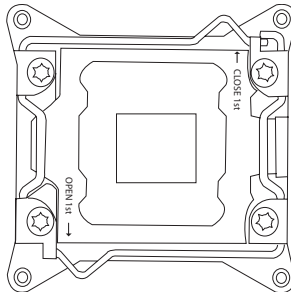
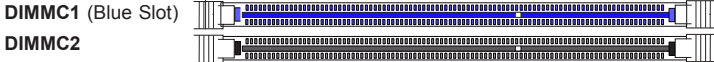

## Memory Population Guidelines

When installing memory modules, the DIMM slots should be populated in the following order: DIMMA1, DIMMB1, DIMMC1, DIMMD1 then DIMMA2, DIMMB2, DIMMC2, DIMMD2.

- Always use DDR3 DIMM modules of the same size, type and speed.
- Mixed DIMM speeds can be installed. However, all DIMMs will run at the speed of the slowest DIMM.
- The motherboard will support odd-numbered modules installed (1 ,3 ,5 ,or 7 modules). However, for best memory performance, install DIMM modules in pairs.

Recommended Population (Balanced)								
DIMMA1	DIMMB1	DIMMC1	DIMMD1	DIMMA2	DIMMB2	DIMMC2	DIMMD2	Total System Memory
2GB	2GB							4GB
2GB	2GB	2GB	2GB					8GB
2GB	2GB	2GB	2GB	2GB	2GB			12GB
2GB	2GB	2GB	2GB	2GB	2GB	2GB	2GB	16GB
4GB	4GB							8GB
4GB	4GB	4GB	4GB					16GB
4GB	4GB	4GB	4GB	4GB	4GB			24GB
4GB	4GB	4GB	4GB	4GB	4GB	4GB	4GB	32GB
8GB	8GB							16GB
8GB	8GB	8GB	8GB					32GB
8GB	8GB	8GB	8GB	8GB	8GB			48GB
8GB	8GB	8GB	8GB	8GB	8GB	8GB	8GB	64GB
16GB	16GB							32GB
16GB	16GB	16GB	16GB					64GB
16GB	16GB	16GB	16GB	16GB	16GB			96GB
16GB	16GB	16GB	16GB	16GB	16GB	16GB	16GB	128GB
32GB	32GB							64GB
32GB	32GB	32GB	32GB					128GB
32GB	32GB	32GB	32GB	32GB	32GB			192GB
32GB	32GB	32GB	32GB	32GB	32GB	32GB	32GB	256GB



**Note:** Up to 256GB of memory are supported using ECC QR (Quad Rank or 4-Rank) registered DIMM technology at 1600/1333/1066/800 MHz. Up to 64GB of memory are supported using non-ECC UDIMMs.

## 2-4 Motherboard Installation

All motherboards have standard mounting holes to fit different types of chassis. Make sure that the locations of all the mounting holes for both motherboard and chassis match. Although a chassis may have both plastic and metal mounting fasteners, metal ones are highly recommended because they ground the motherboard to the chassis. Make sure that the metal standoffs click in or are screwed in tightly. Then use a screwdriver to secure the motherboard onto the motherboard tray.

### Tools Needed



### Location of Mounting Holes

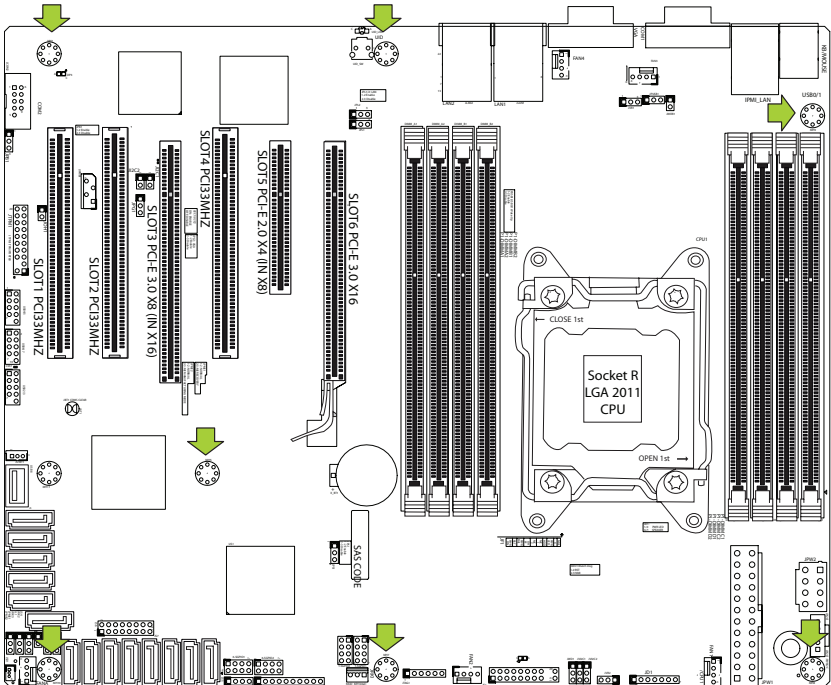

**Caution:** 1) To prevent damage to the motherboard and its components, please do not use a force greater than 8 lb/inch on each mounting screw during motherboard installation. 2) Some components are very close to the mounting holes. Please take precautionary measures to avoid damaging these components when installing the motherboard to the chassis.

## Installing the Motherboard

1. Install the I/O shield into the chassis.

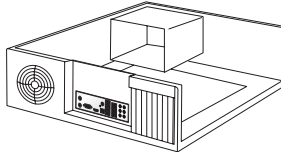

2. Locate the mounting holes on the motherboard.
3. Locate the matching mounting holes on the chassis. Align the mounting holes on the motherboard against the mounting holes on the chassis.
4. Install standoffs in the chassis as needed.

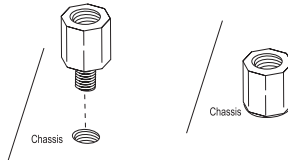

5. Install the motherboard into the chassis carefully to avoid damaging motherboard components.
6. Using the Philips screwdriver, insert a Pan head #6 screw into a mounting hole on the motherboard and its matching mounting hole on the chassis.

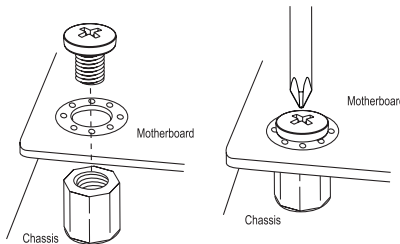

7. Repeat Step 5 to insert #6 screws into all mounting holes.
8. Make sure that the motherboard is securely placed in the chassis.



**Note:** Images displayed are for illustration only. Your chassis or components might look different from those shown in this manual.

## 2-5 Connectors/I/O Ports

The I/O ports are color coded in conformance with the industry standards. See the figure below for the colors and locations of the various I/O ports.

### Motherboard I/O Backpanel

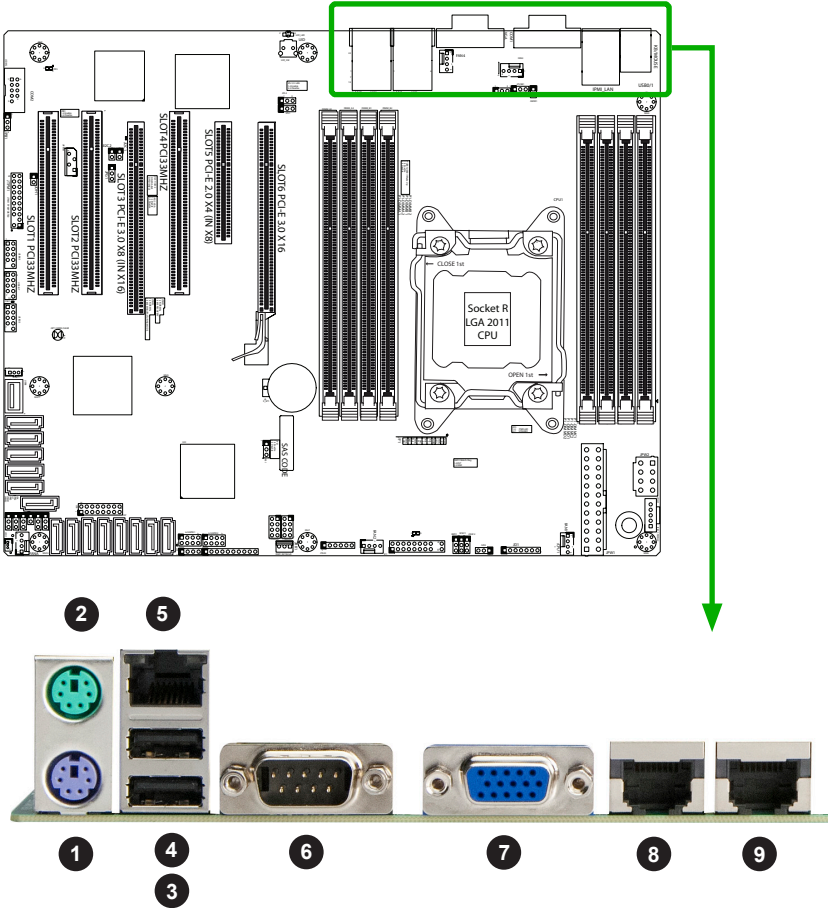

Motherboard I/O Backpanel	
1. Keyboard (Purple)	7. VGA
2. PS/2 Mouse (Green)	8. LAN1*
3. USB Port 0	9. LAN2*
4. USB Port 1	*10Gb LAN ports on the X9SRH-7TF
5. IPMI LAN	
6. COM1	

## ATX PS/2 Keyboard/Mouse Ports

The ATX PS/2 keyboard and PS/2 mouse are located next to the Back Panel USB Ports 0/1 on the motherboard. See the table at right for pin definitions.

PS/2 Keyboard/Mouse Pin Definitions			
PS2 Keyboard		PS2 Mouse	
Pin#	Definition	Pin#	Definition
1	KBDAT_R	7	MSDAT_R
2	No Connection	8	No Connection
3	Ground	9	Ground
4	P5V_DUAL	10	P5V_DUAL
5	KBCLK_R	11	MSCLK_R
6	No Connection	12	No Connection
13	Ground	17	Ground
14	Ground		
15	Ground		
16	Ground		

### Mouse

1. Keyboard (Purple)

2. Mouse (Green)

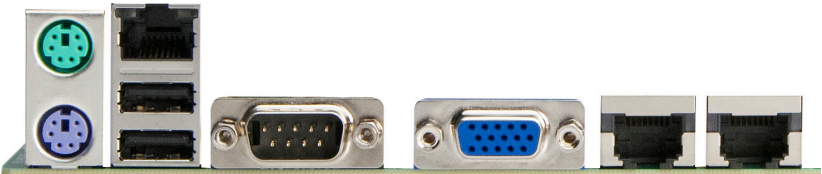

### Keyboard

### Universal Serial Bus (USB)

Two Universal Serial Bus ports (USB 0/1) are located on the I/O back panel. In addition, six USB headers (USB 2/3, USB 4/5, USB 6/7) are used to provide front chassis access. There is also one Type A internal USB port located on USB 8. (USB Cables are not included). See the tables on the right for pin definitions.

1. [Backpanel USB 0](#)
2. [Backpanel USB 1](#)
3. [Front Panel USB 4/5](#)
4. [Front Panel USB 6/7](#)
5. [Front Panel USB 2/3](#)
6. [Type A USB 8](#)

Back Panel USB Ports Pin Definitions			
Pin#	Definition	Pin#	Definition
1	+5V	5	+5V
2	USB_PN0	6	USB_PN1
3	USB_PP0	7	USB_PP1
4	Ground	8	Ground

Front Panel USB Headers Pin Definitions			
Pin#	Definition	Pin#	Definition
1	+5V	6	USB_PP5
2	+5V	7	Ground
3	USB_PN4	8	Ground
4	USB_PN5	9	Key
5	USB_PP4	10	No Connection

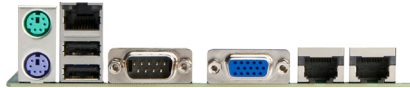

- 2
- 1

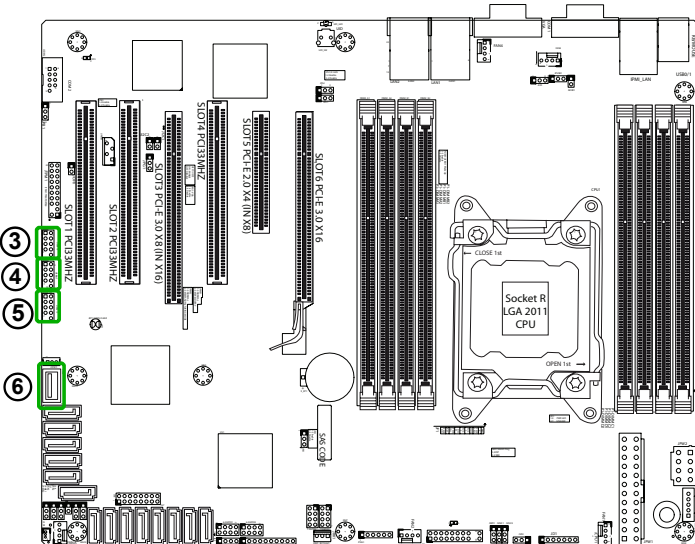

## Ethernet Ports

Two Ethernet ports (LAN1/LAN2) are located next to the VGA port on the I/O Backpanel. In addition, an IPMI Dedicated LAN port is also located above USB 0/1 to provide a dedicated network connection for IPMI 2.0 on the motherboard.

LAN Connection Speeds:

X9SRH-7F: 1Gb/sec

X9SRH-7TF: 10Gb/sec

LAN Ports Pin Definition			
Pin#	Definition	Pin#	Definition
1	TRCT2	13	IETCT
2	TRD2+	14	IET+
3	TRD2-	15	IET-
4	TRD3+		
5	TRD3-	17	L1-COMMON
6	TRCT3	18	L1-GRE-
7	TRCT1	19	L2-YEL
8	TRD1+	20	L2-COMMON
9	TRD1-	21	L2-GRE-
10	TRD4+	22	CG1
11	TRD4-	23	CG2
12	TRCT4	24	

(NC: No Connection)

1. LAN1

2. LAN2

3. IPMI Dedicated LAN

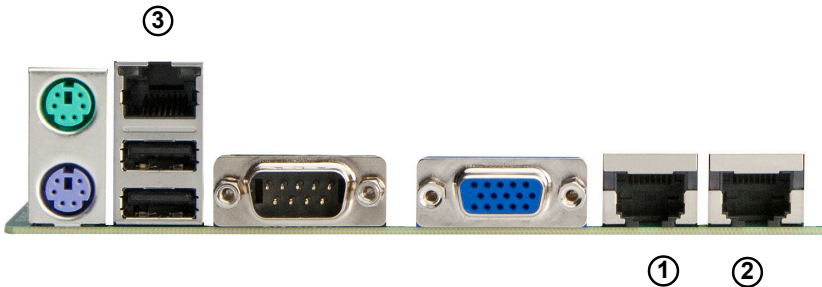



## Video Port

A Video (VGA) port is located next to the COM Port on the I/O backpanel. This port is used to provide a connection for video and graphics display. Refer to the board layout below for the location.

VGA Pin Definitions			
Pin#	Definition	Pin#	Definition
1	Red	10	Ground
2	Green	11	NC
3	Blue	12	MS1: SDA (DDC Data)
4	NC	13	HSYNC
5	Ground	14	VSYSNC
6	Ground	15	MS3: SCL (DDC CLK)
7	Ground	16	Case
8	Ground	17	Case
9	5V		

NC= No Connection

### 1. VGA

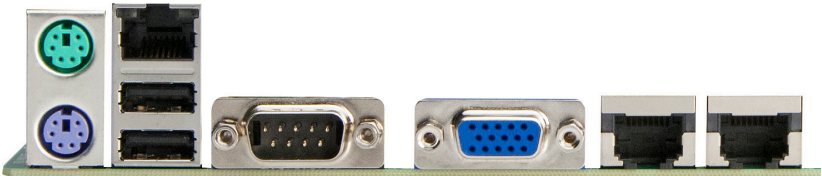

①

## Front Control Panel

JF1 contains header pins for various buttons and indicators that are normally located on a control panel at the front of the chassis. These connectors are designed specifically for use with Supermicro server chassis. See the figure below for the descriptions of the various control panel buttons and LED indicators. Refer to the following section for descriptions and pin definitions.

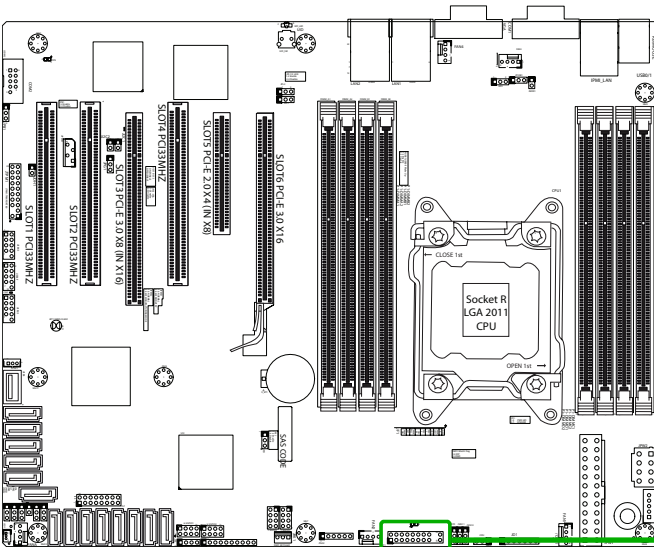
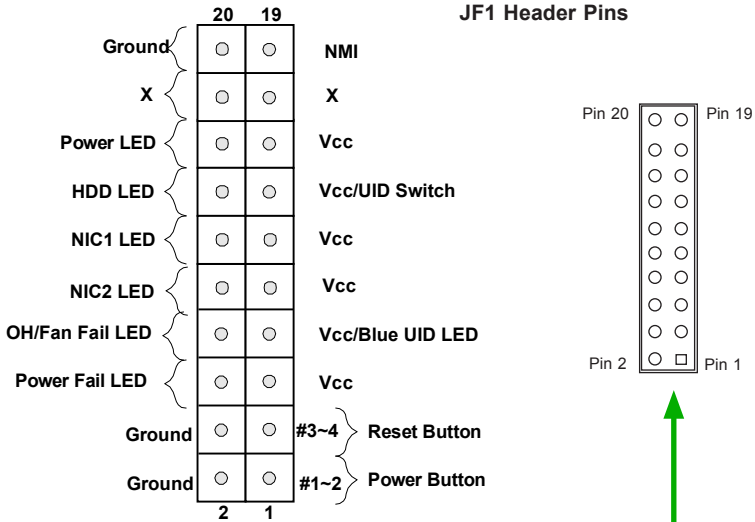

## Front Control Panel Pin Definitions

### Power LED

The Power LED connection is located on pins 15 and 16 of JF1. Refer to the table on the right for pin definitions.

Power LED Pin Definitions (JF1)	
Pin#	Definition
15	+3.3V
16	Ground

### HDD LED

The HDD LED connection is located on pins 13 and 14 of JF1. Attach a cable here to indicate the status of HDD-related activities, including IDE, SATA activities. See the table on the right for pin definitions.

HDD LED Pin Definitions (JF1)	
Pin#	Definition
13	+3.3V
14	HD Active

### Power Fail LED

The Power Fail LED connection is located on pins 5 and 6 of JF1. Refer to the table on the right for pin definitions.

PWR Fail LED Pin Definitions (JF1)	
Pin#	Definition
5	Vcc
6	Ground

A. PWR LED

B. HDD LED

C. PWR Fail LED

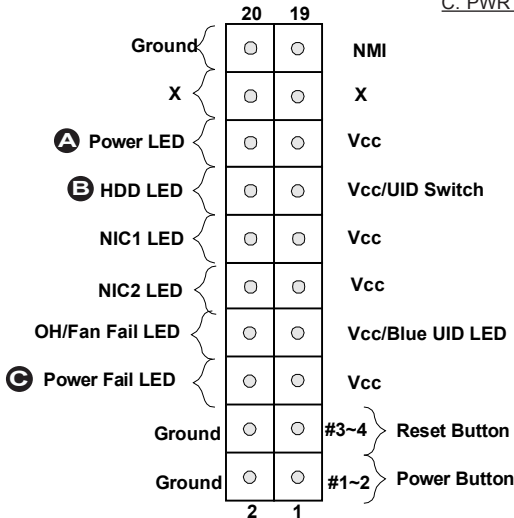

**NIC1/NIC2 (LAN1/LAN2)**

The NIC (Network Interface Controller) LED connection for LAN port 1 is located on pins 11 and 12 of JF1, and the LED connection for LAN Port 2 is on Pins 9 and 10. NIC1 LED and NIC2 LED are 2-pin NIC LED headers. Attach NIC LED cables to NIC1 and NIC2 LED indicators to display network activities. Refer to the table on the right for pin definitions.

LAN1/LAN2 LED Pin Definitions (JF1)	
Pin#	Definition
9/11	Vcc
10/12	LAN Active

**Overheat (OH)/Fan Fail / UID LED**

Connect an LED cable to the OH/Fan Fail connections on pins 7 and 8 of JF1 to display signals or to provide advanced warnings for chassis overheat/fan failure. Refer to the table on the right for pin definitions. The UID LED is used together with the UID Switch.

OH/Fan Fail LED Pin Definitions (JF1)	
Pin#	Definition
7	Vcc/Blue UID LED
8	OH/Fan Fail LED

OH/Fan Fail Indicator Status	
State	Definition
Off	Normal
On	Overheat
Flashing	Fan Fail

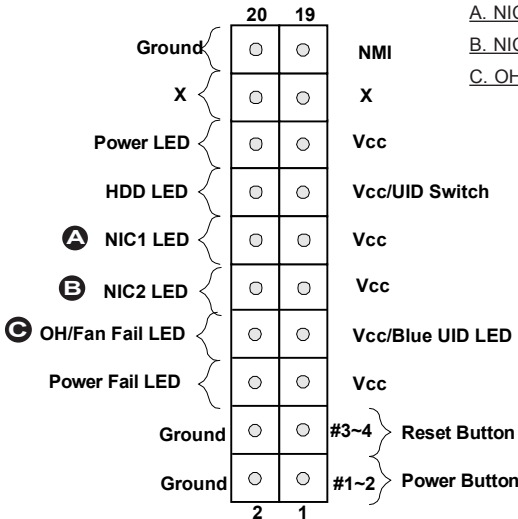

- A. NIC1 LED
- B. NIC2 LED
- C. OH/Fan Fail / UID LED

## NMI Button

The non-maskable interrupt button header is located on pins 19 and 20 of JF1. Refer to the table on the right for pin definitions.

NMI Button Pin Definitions (JF1)	
Pin#	Definition
19	Control
20	Ground

## Reset Button

The Reset Button connection is located on pins 3 and 4 of JF1. Attach it to a hardware reset switch on the computer case to reset the system. Refer to the table on the right for pin definitions.

Reset Button Pin Definitions (JF1)	
Pin#	Definition
3	Reset
4	Ground

## Power Button

The Power Button connection is located on pins 1 and 2 of JF1. Momentarily contacting both pins will power on/off the system. This button can also be configured to function as a suspend button (with a setting in the BIOS - see Chapter 4). To turn off the power in the suspend mode, press the button for at least 4 seconds. Refer to the table on the right for pin definitions.

Power Button Pin Definitions (JF1)	
Pin#	Definition
1	Signal
2	Ground

[A. NMI Button](#)

[B. Reset Button](#)

[C. PWR Button](#)

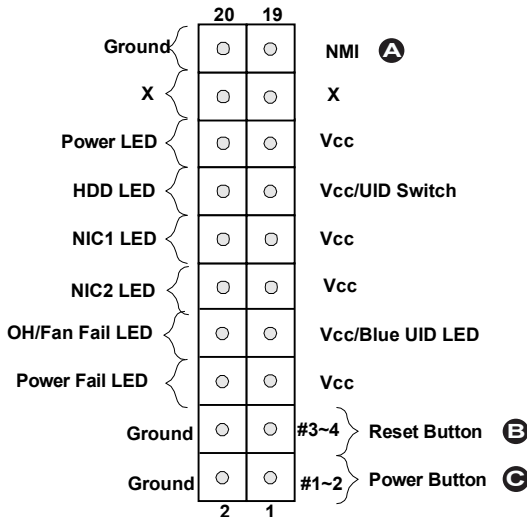

## 2-6 Connecting Cables & Optional Devices

This section provides brief descriptions and pin-out definitions for onboard headers and connectors. Be sure to use the correct cable for each header or connector.

### ATX Main PWR (JPW1) & CPU PWR Connectors (JPW2)

The 24-pin main power connector (JPW1) is used to provide power to the motherboard. The 8-pin CPU PWR connector (JPW2) is also required for the processor. These power connectors meet the SSI EPS 12V specification. See the table on the right for pin definitions.

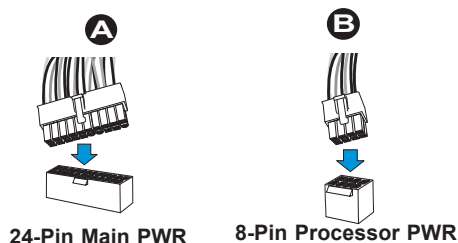

A. 24-Pin ATX Main PWR

B. 8-Pin Processor PWR

ATX Power 24-pin Connector Pin Definitions (JPW1)			
Pin#	Definition	Pin #	Definition
13	+3.3V	1	+3.3V
14	-12V	2	+3.3V
15	Ground	3	Ground
16	PS_ON	4	+5V
17	Ground	5	Ground
18	Ground	6	+5V
19	Ground	7	Ground
20	-5V	8	PWR_OK
21	+5V	9	5VSB
22	+5V	10	+12V
23	+5V	11	+12V
24	Ground	12	+3.3V

12V 8-pin Power Connector Pin Definitions	
Pins	Definition
1 through 4	Ground
5 through 8	+12V

(Required)

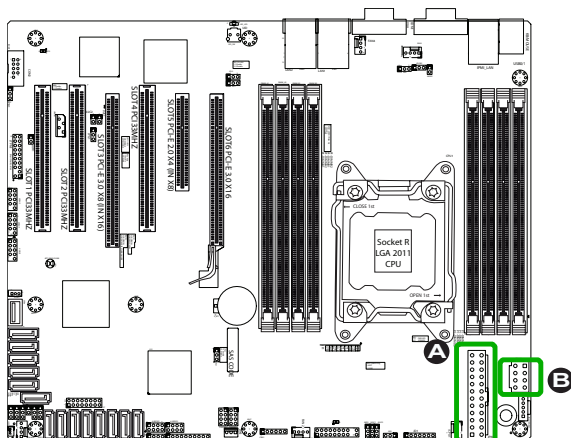

## Fan Headers (FAN1~4, FANA)

The X9SRH series has five fan headers (Fan 1~Fan 4 and Fan A). These fans are 4-pin fan headers. Pins 1-3 of these fan headers are backward compatible with the traditional 3-pin fans. However, the fan speed control setting in the BIOS Hardware Monitoring section will only work with 4-pin fans. This allows the BIOS to automatically set fan speeds based on the system temperature. Refer to the table on the right for pin definitions and fan usage.

 **Note:** We recommend that 4-pin fans are used on the motherboard.

Fan Header Pin Definitions	
Pin#	Definition
1	Ground (Black)
2	+12V (Red)
3	Tachometer
4	PWM_Control

Fan Usage	
FAN#	Use for
1~4	System/CPU
A	I/O Cards

## Chassis Intrusion (JL1)

A Chassis Intrusion header is located at JL1 on the motherboard. Attach the appropriate cable from the chassis to inform you of a chassis intrusion when the chassis is opened.

Chassis Intrusion Pin Definitions (JL1)	
Pin#	Definition
1	Intrusion Input
2	Ground

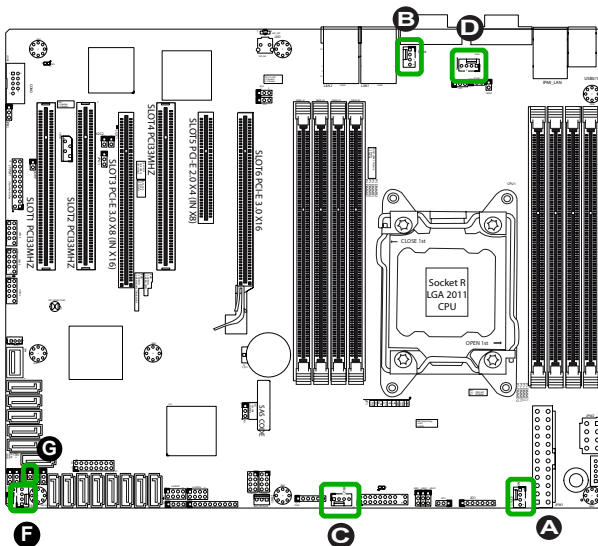

- A. Fan 1
- B. Fan 4
- C. Fan 2
- D. Fan 3
- F. Fan A
- G. Chassis Intrusion

**Speaker (JD1)**

On the JD1 header, Pins 6~7 are used for the internal speaker. Close Pins 6~7 with a jumper or cap to use the onboard speaker. If you wish to use an external speaker, attach the external speaker's cable to Pins 1~4. See the table on the right for pin definitions.

Speaker Connector Pin Definitions	
Pin Setting	Definition
Pins 6~7	Internal Speaker
Pins 1~3	PWR LED
Pins 4~7	External Speaker

**Internal Buzzer (SP1)**

The Internal Buzzer (SP1) can be used to provide audible indications for various beep codes. See the table on the right for pin definitions.

Internal Buzzer Pin Definition		
Pin#	Definitions	
Pin 1	Pos. (+)	Beep In
Pin 2	Neg. (-)	Alarm Speaker

**Wake-On-LAN (JSTBY1)**

The Wake-On-LAN header is located at JSTBY1 on the motherboard. See the table on the right for pin definitions. (You must also have a LAN card with a Wake-On-LAN connector and cable to use this feature.)

Wake-On-LAN Pin Definitions	
Pin#	Definition
1	+5V Standby
2	Ground
3	Wake-up

- A. Internal Buzzer
- B. Speaker Header
- C. Wake On LAN

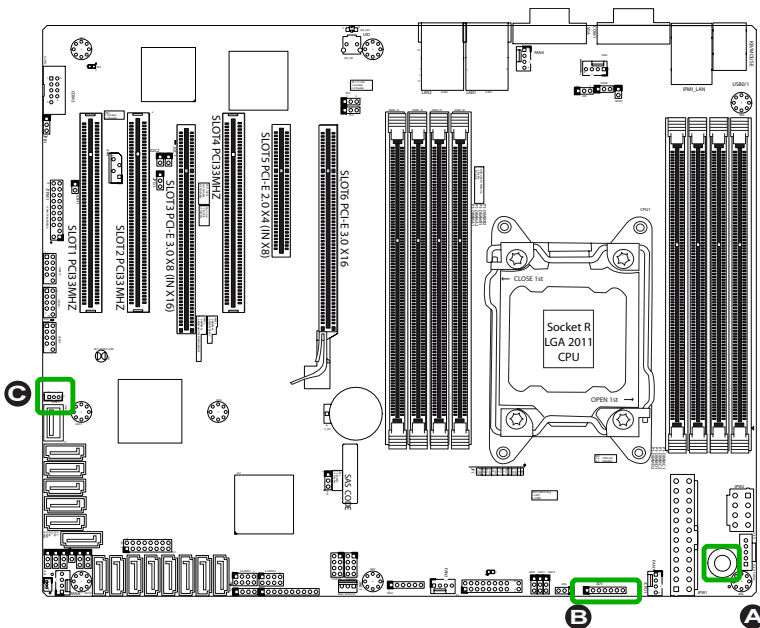

### Power Supply I<sup>2</sup>C (JPI2C1)

The Power Supply I2C Connector, located at JPI2C, monitors the status of the power supply, fan and system temperature. See the table on the right for pin definitions.

PWR Supply I <sup>2</sup> C Pin Definitions	
Pin#	Definition
1	Clock
2	Data
3	PWR Fail
4	Ground
5	3.3V

### DOM PWR Connector (JSD1)

The Disk-On-Module (DOM) power connector, located at JSD1, provides 5V (Gen1/Gen) power to a solid\_state DOM storage device connected to one of the SATA ports. See the table on the right for pin definitions.

DOM PWR Pin Definitions	
Pin#	Definition
1	5V
2	Ground
3	Ground/NC*

#### A. Power Supply I<sup>2</sup>C

#### B. DOM Power

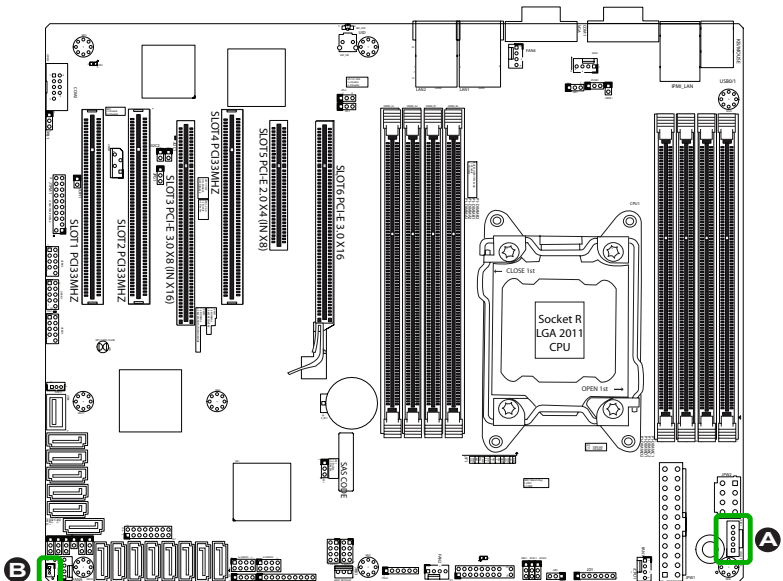

**T-SGPIO 1/2 & 6-SGPIO 1/2 Headers**

Two T-SGPIO (Serial-Link General Purpose Input/Output) headers are located next to the I-SATA Ports on the motherboard. Additionally, two 6-SGPIO ports (for SAS2) are also located next to the SAS ports. These headers are used to communicate with the enclosure management chip in the system. See the table on the right for pin definitions. Refer to the board layout below for the locations of the headers.

Serial_Link-SGPIO Pin Definitions			
Pin#	Definition	Pin	Definition
1	NC	2	NC
3	Ground	4	DATA Out
5	Load	6	Ground
7	Clock	8	NC

NC: No Connections

**TPM Header (JTPM1)**

This header is used to connect a Trusted Platform Module (TPM), which is available from a third-party vendor. A TPM is a security device that supports encryption and authentication in hard drives. It enables the motherboard to deny access if the TPM associated with the hard drive is not installed in the system. See the table on the right for pin definitions.

Trusted Platform Module Header Pin Definitions			
Pin #	Definition	Pin #	Definition
1	LCLK	2	GND
3	LFRAME	4	No Pin
5	LRESET	6	VCC5
7	LAD3	8	LAD2
9	VCC3	10	LAD1
11	LAD0	12	GND
13	SMBCLK	14	SMBDAT
15	SB3V	16	SERIRQ
17	GND	18	CLKRUN
19	LPCPD	20	LDRQ1

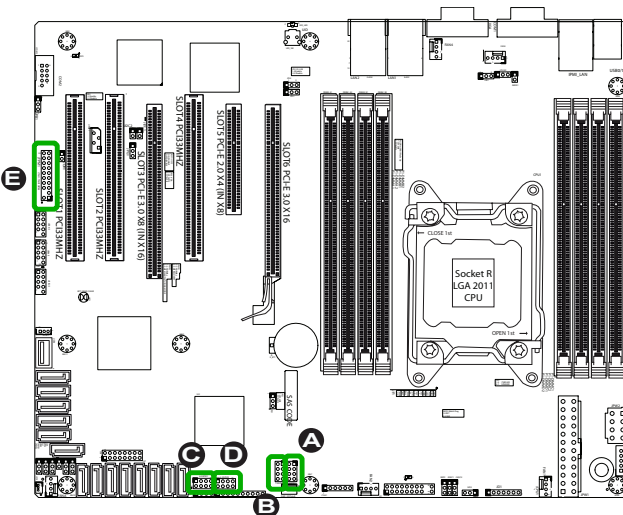

- A. T-SGPIO 1
- B. T-SGPIO 2
- C. 6-SGPIO 1
- D. 6-SGPIO 2
- E. TPM Header

## Unit ID Switch (UID SW)

The rear UID switch, the rear UID LED and front UID LED on JF1 are designed to work together. When the user pushes the rear UID switch, the blue backpanel UID LED and front UID LED will turn on. Push the rear UID switch again to turn off UID LED and the front UID LED. This provides easy identification of a system unit that may be in need of service.

UID Switch	
Pin#	Definition
1	Button In
2	Ground
3	Ground
4	Ground

Overheat LED Pin Definitions	
Pin#	Definition
1	P3V3
2	OH Active

## Overheat/Fan Fail LED (JOH1)

The JOH1 header is used to connect an LED to provide warnings of chassis overheat. This LED will also blink to indicate a fan failure. Refer to the table on right for pin definitions.

OH/Fan Fail LED Pin Definitions	
State	Message
Solid	Overheat
Blinking	Fan Fail

### A. UID Switch

### B. Overheat/Fan Fail LED

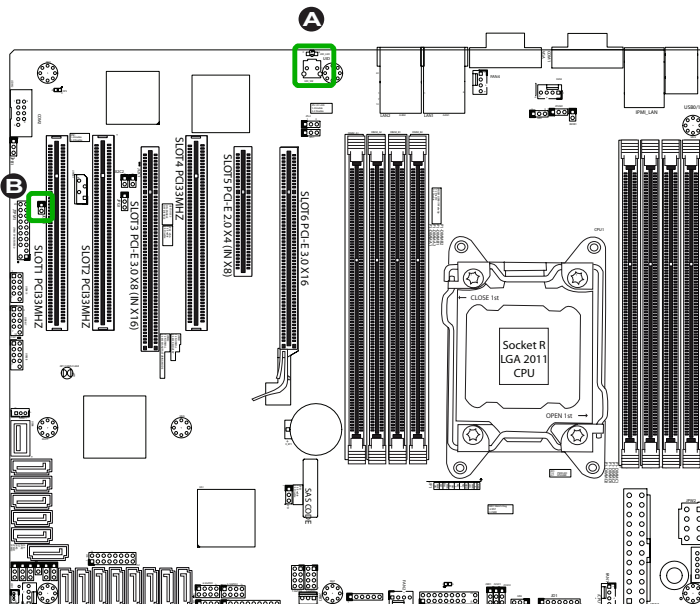

### System Management Bus (JIPMB1)

A System Management Bus header for the IPMI slot is located at IPMB. Connect the appropriate cable here to use the IPMB I2C connection on your system.

System Management Bus	
Pin#	Definition
1	Clock
2	Ground
3	Data
4	No Connection

### Wake-On-Ring

The Wake-On-Ring header is designated JWOR1. This function allows your computer to wake up when receiving an incoming call to the modem when in the suspend state. See the table on the right for pin definitions. You must have a Wake-On-Ring card and cable to use this feature.

Wake-On-Ring Pin Definitions (JWOR1)	
Pin#	Definition
1	Ground
2	Wake-up

A. System Management Bus

B. Wake On Ring

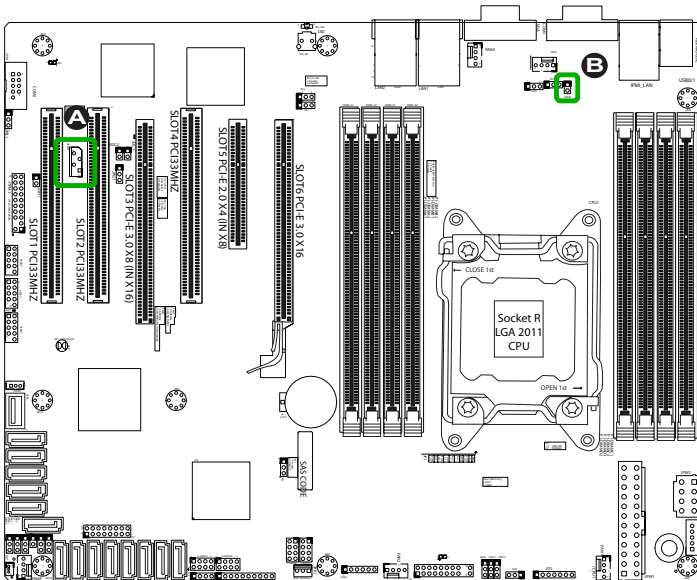

## RAID Key Header (JRK1)

The RAID key header supports an optional RAID key (available separately). When plugged into this header, it will allow the user to enable the onboard SAS controller for software RAID 5 support (Intel or LSI).

 **Note:** Install an Intel RAID key on pins 1-2 and an LSI RAID Key on pins 2-3.

RAID Key Header (Intel/LSI)	
Pin#	Definition
1	RAID Key (Intel)
2	GND
3	RAID Key (LSI)

A. RAIDKey Header

A. RAIDKey Header

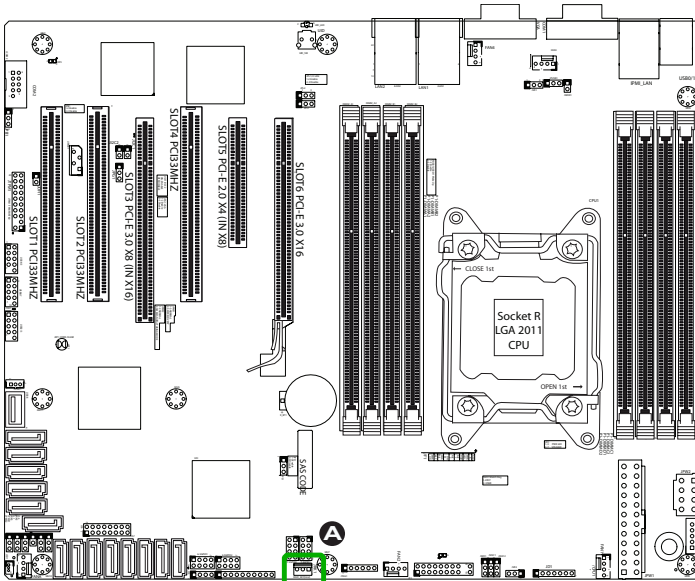

## 2-7 Jumper Settings

### Explanation of Jumpers

To modify the operation of the motherboard, jumpers can be used to choose between optional settings. Jumpers create shorts between two pins to change the function of the connector. Pin 1 is identified with a square solder pad on the printed circuit board.

 **Note:** On two-pin jumpers, "Closed" means the jumper is on, and "Open" means the jumper is off the pins.

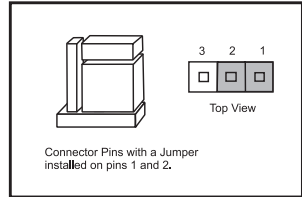
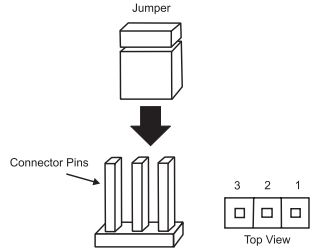

### LAN Port Enable/Disable (JPL1~2)

Jumpers JPL1/JPL2 enable or disable LAN Port 1/LAN Port 2 on the motherboard. See the table on the right for jumper settings. The default setting is enabled.

GLAN Enable Jumper Settings	
Pin#	Definition
1-2	Enabled (default)
2-3	Disabled

A. LAN Port 1 Enable

B. LAN Port 2 Enable

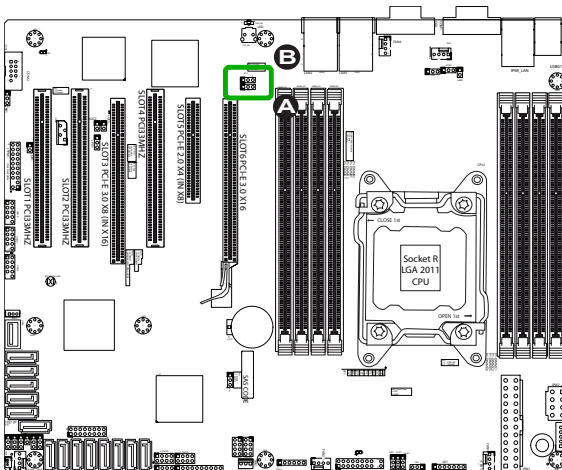

## CMOS Clear (JBT1)

JBT1 is used to clear CMOS. Instead of pins, this "jumper" consists of contact pads to prevent accidental clearing of CMOS. To clear CMOS, use a metal object such as a small screwdriver to touch both pads at the same time to short the connection. Always remove the AC power cable from the system before clearing CMOS.

**Important:** For an ATX power supply, you must completely shut down the system, remove the AC power cable and then short JBT1 to clear CMOS.

## PCI-E Slot SMB Enable (JI2C1/JI2C2)

Use Jumpers JI2C1/JI2C2 to enable PCI-E SMB (System Management Bus) support to improve system management for the PCI-E slots. See the table on the right for jumper settings.

PCI-E Slot SMB Enable Jumper Settings	
Jumper Setting	Definition
Short	Enabled
Open (Default)	Disabled

A. Clear CMOS

B. JI2C2

C. JI2C1

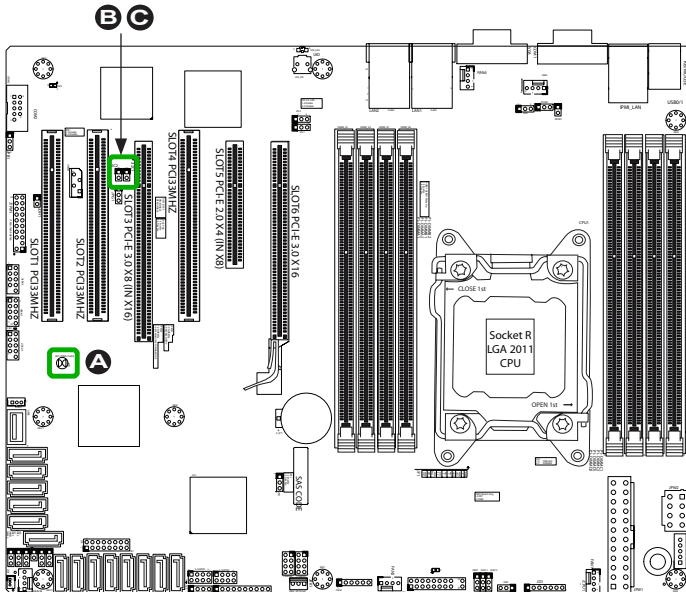

**VGA Enable (JPG1)**

JPG1 allows you to enable or disable the onboard VGA connector. The default position is on pins 1 and 2 to enable VGA. See the table on the right for jumper settings.

VGA Enable/Disable Jumper Settings (JPG1)	
Both Jumpers	Definition
Pins 1-2	Enabled (Default)
Pins 2-3	Disabled

**Watch Dog Reset (JWD1)**

Watch Dog (JWD1) is a system monitor that can reboot the system when a software application hangs. Close pins 1-2 to reset the system if an application hangs. Close Pins 2-3 to generate a non-maskable interrupt signal for the application that hangs. See the table on the right for jumper settings. Watch Dog must also be enabled in the BIOS.

Watchdog Enable/Disable Jumper Settings (JWD1)	
Jumpers	Definition
Pins 1-2	Reset (Default)
Pins 2-3	NMI

A. VGA Enable

B. Watch Dog Reset

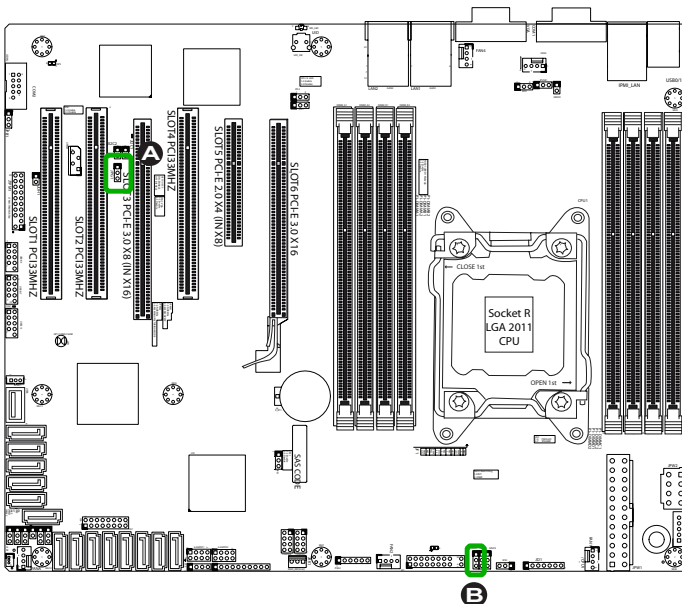

## USB Wake-Up (JPUSB1)

Use the jumper JPUSB1 to "wake-up" your system by pressing a key on a USB keyboard or clicking the USB mouse connected to the backpanel USB Ports 0/1. JPUSB1 is used together with a USB Wake-Up feature in the BIOS. Enable this jumper and the USB support in the BIOS to wake up your system via USB devices.

 **Note:** When the USB is set to Enabled in the BIOS, and JPUSB1 is set to Disabled, remove the USB devices from Backplane USB Ports 0/1 before the system goes into the standby mode.

## BMC Enable/Disable (JPB1)

JPB1 is used to enable or disable the BMC (Baseboard Management Control) chip and the onboard IPMI connection. This jumper is used together with the IPMI settings in the BIOS. See the table on the right for jumper settings.

USB 0/1 Wake-up Enable Jumper Settings	
Pin#	Definition
1-2	Enabled (Default)
2-3	Disabled

BMC IPMI Enable/Disable Jumper Settings	
Settings	Definition
Pins 1-2	Enabled (Default)
Pins 2-3	Disabled

A. USB 0/1 Wake-up

B. BMC Enable/Disable

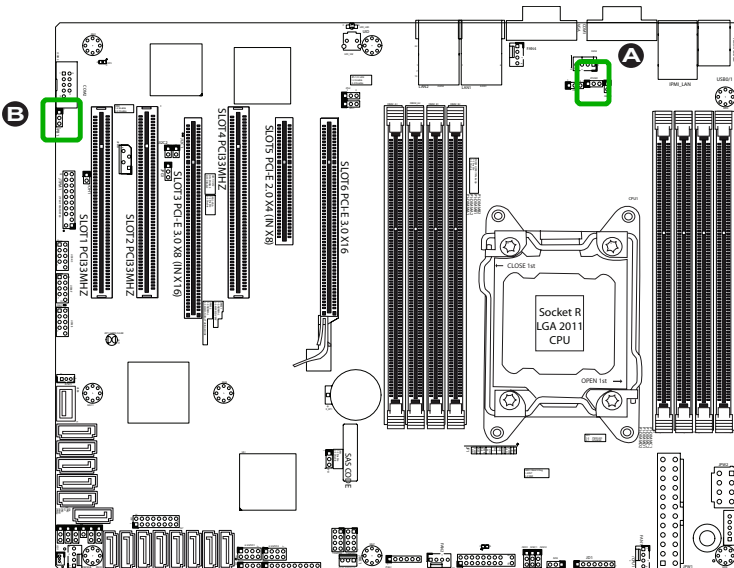



## 2-8 Onboard Indicators

### LAN Port LEDs

The LAN ports are located on the I/O backpanel of the motherboard. Each Ethernet LAN port has two LEDs. A blinking Activity LED indicates there is data passing through the port, while the Link LED may be green, amber, or off to indicate the speed of the connection. See the tables at right for more information.

### IPMI Dedicated LAN LEDs

In addition to the LAN ports, an IPMI Dedicated LAN port is also located on X9SRH series. The yellow LED on the right indicates activity, while the green LED on the left indicates the speed of the connection. See the tables at right for more information.

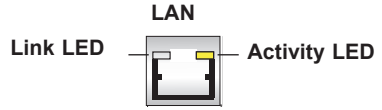

LAN Link LEDs (Green/Amber/Off)	
LED Color	Definition
Off	100 Mbps
Amber	1 Gbps
Green	10 Gbps (if supported)

 Note: 10 Mbps is not supported. 10Gbps is only supported on some motherboards.

IPMI LAN Link LED (Left) & Activity LED (Right)		
Status	Color	Definition
Link (Left)	Green: Solid	100 Mbps
Activity (Right)	Yellow: Blinking	Active

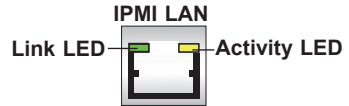

A. LAN1

B. LAN2

C. IPMI Dedicated LAN

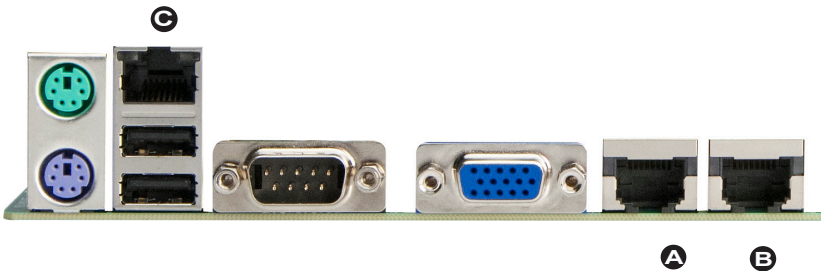

Motherboard I/O Backpanel

**Rear Unit ID LED (UID LED)**

The rear Unit ID LED is located at UID LED on the backpanel. This LED is used in conjunction with the rear UID switch to provide easy identification of a system that might be in need of service.

Rear UID LED LED Settings	
Blue: Solid	UID Toggled On

**IPMI Heartbeat LED (DP3)**

The IPMI Heartbeat LED is located at DP3. When DP3 blinks, the IPMI feature is functioning properly. Refer to the table on the right for details. Also see the layout below for the LED location. This is supported on the X9SRI-3F/X9SRE-3F only.

IPMI Heartbeat LED Indicator LED Settings	
Green: Blinking	IPMI is ready for use

**Onboard Power LED (DP2)**

An Onboard Power LED is located at PWR LED on the motherboard. When PWR LED is on, it means that the AC power cable is connected, the power supply switch and soft switch are on, and the system is running.

Onboard PWR LED (DP2) LED Status	
Status	Definition
Off	System Off (Soft Switch)
On	System is Running

- A. Rear Unit ID LED
- B. IPMI Heartbeat LED
- C. Power LED

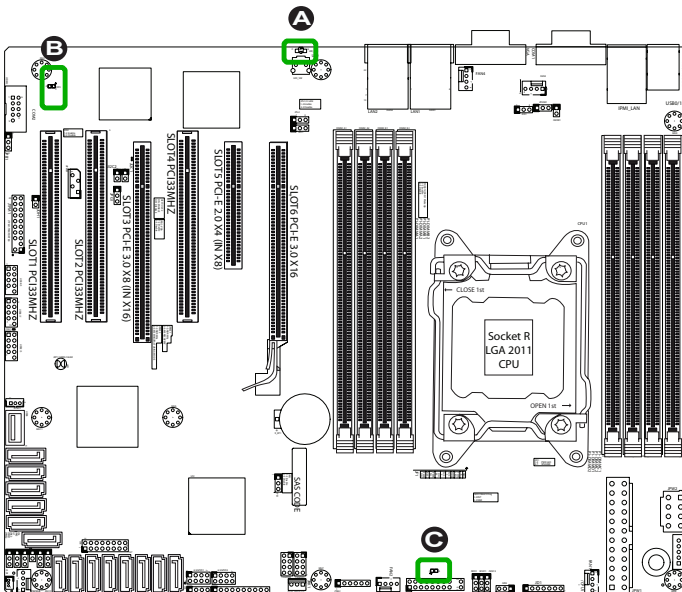

## 2-9 SATA and SAS Connections

### SATA/SAS Connections

Six Serial ATA (SATA) connectors (I-SATA 0~5) are located on the motherboard. I-SATA 0/1 supports data transfer rates of up to 6Gb/s (SATA 3.0), while I-SATA 2~5 supports data transfer rates of up to 3Gb/s (SATA 2.0). Please see the pin definitions on the right table.

In addition to these six SATA ports, eight 3Gb/s SAS connections (Serial-Attached SCSI) are also located on the motherboard.

SATA/SAS Connectors Pin Definitions	
Pin#	Signal
1	Ground
2	SATA_TXP
3	SATA_TXN
4	Ground
5	SATA_RXN
6	SATA_RXP
7	Ground

- |                          |                  |
|--------------------------|------------------|
| <u>1. I-SATA 0 (3.0)</u> | <u>A. L-SAS0</u> |
| <u>2. I-SATA 1 (3.0)</u> | <u>B. L-SAS1</u> |
| <u>3. I-SATA 2 (2.0)</u> | <u>C. L-SAS2</u> |
| <u>4. I-SATA 3 (2.0)</u> | <u>D. L-SAS3</u> |
| <u>5. I-SATA 4 (2.0)</u> | <u>E. L-SAS4</u> |
| <u>6. I-SATA 5 (2.0)</u> | <u>F. L-SAS5</u> |
|                          | <u>G. L-SAS6</u> |
|                          | <u>H. L-SAS7</u> |

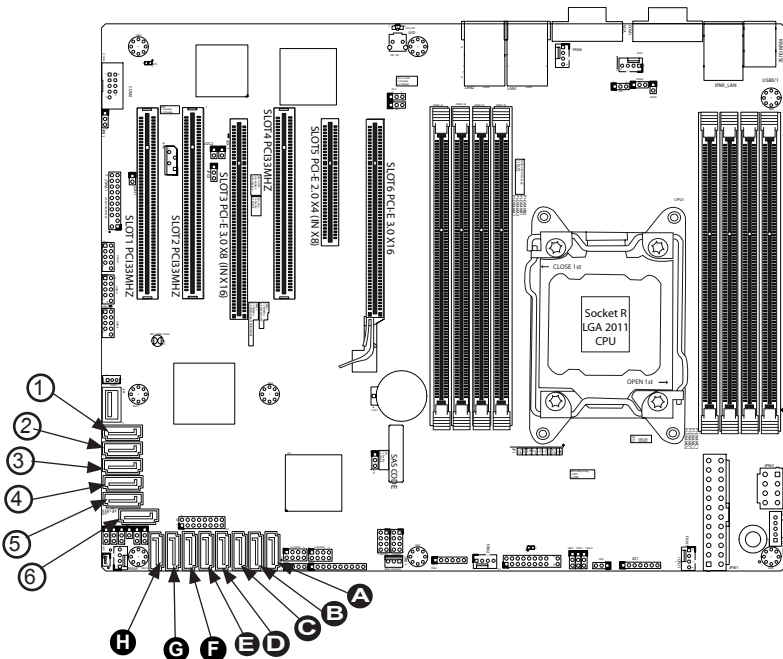



## Chapter 3

# Troubleshooting

### 3-1 Troubleshooting Procedures

Use the following procedures to troubleshoot your system. If you have followed all of the procedures below and still need assistance, refer to the 'Technical Support Procedures' and/or 'Returning Merchandise for Service' section(s) in this chapter. Always disconnect the AC power cable before adding, changing or installing any hardware components.

#### Before Power On

1. Make sure that the Standby is not on. (**Note:** If it is on, the onboard power is on. Be sure to unplug the power cable before installing or removing the components.)
2. Make sure that there are no short circuits between the motherboard and chassis.
3. Disconnect all ribbon/wire cables from the motherboard, including those for the keyboard and mouse. Also, be sure to remove all add-on cards.
4. Install a CPU and heatsink (-be sure that it is fully seated) and then connect the chassis speaker and the power LED to the motherboard. Check all jumper settings as well.

#### No Power

1. Make sure that there are no short circuits between the motherboard and chassis.
2. Make sure that all jumpers are set to their default positions.
3. Check if the 115V/230V switch on the power supply is properly set.
4. Turn the power switch on and off to test the system.
5. The battery on your motherboard may be old. Check to make sure that it still supplies ~3VDC. If it does not, replace it with a new one.

## **No Video**

1. If the power is on, but you have no video--in this case, you will need to remove all the add-on cards and cables first.
2. Use the speaker to determine if any beep codes exist. (Refer to Appendix A for details on beep codes.)
3. Remove all memory modules and turn on the system. (If the alarm is on, check the specs of memory modules, reset the memory or try a different one.)

## **Memory Errors**

1. Make sure that the DIMM modules are properly installed and fully seated in the slots.
2. You should be using memory recommended by Supermicro (see Section 2-3). Also, it is recommended that you use the memory modules of the same type and speed for all DIMMs in the system. Do not use memory modules of different sizes, different speeds and different types on the same motherboard.
3. Check for bad DIMM modules or slots by swapping modules between slots to see if you can locate the faulty ones.
4. Check the switch of 115V/230V power supply.

## **When You Lose the System's Setup Configuration**

1. Please be sure to use a high quality power supply. A poor quality power supply may cause the system to lose CMOS setup information. Refer to Section 1-6 for details on recommended power supplies.
2. The battery on your motherboard may be old. Check to verify that it still supplies ~3VDC. If it does not, replace it with a new one.
3. If the above steps do not fix the Setup Configuration problem, contact your vendor for repairs.

---

## 3-2 Technical Support Procedures

Before contacting Technical Support, please make sure that you have followed all the steps listed below. Also, Note that as a motherboard manufacturer, Supermicro does not sell directly to end users, so it is best to first check with your distributor or reseller for troubleshooting services. They should know of any possible problem(s) with the specific system configuration that was sold to you.

1. Please go through the 'Troubleshooting Procedures' and 'Frequently Asked Question' (FAQ) sections in this chapter or see the FAQs on our website (<http://www.supermicro.com/support/faqs/>) before contacting Technical Support.
2. BIOS upgrades can be downloaded from our website at (<http://www.supermicro.com/support/bios/>).



**Note:** Not all BIOS can be flashed. Some cannot be flashed; it depends on the boot block code of the BIOS.

3. If you've followed the instructions above to troubleshoot your system, and still cannot resolve the problem, then contact Supermicro's technical support and provide them with the following information:
  - Motherboard model and PCB revision number
  - BIOS release date/version (this can be seen on the initial display when your system first boots up)
  - System configuration
  - An example of a Technical Support form is on our website at (<http://www.supermicro.com/support/contact.cfm>).
4. Distributors: For immediate assistance, please have your account number ready when placing a call to our technical support department. We can be reached by e-mail at [support@supermicro.com](mailto:support@supermicro.com), by phone at: (408) 503-8000, option 2, or by fax at (408)503-8019.

### 3-3 Frequently Asked Questions

**Question:** What type of memory does my motherboard support?

**Answer:** Please see Section 2-3 for a comprehensive answer.

**Question:** How do I update my BIOS?

**Answer:** It is recommended that you **do not** upgrade your BIOS if you are not experiencing any problems with your system. Updated BIOS files are located on our website at <http://www.supermicro.com/support/bios/>. Please check our BIOS warning message and the information on how to update your BIOS on our website. Select your motherboard model and download the BIOS ROM file to your computer. Also, check the current BIOS revision to make sure that it is newer than your BIOS before downloading. Please unzip the BIOS file onto a bootable device or a USB pen/thumb drive. To flash the BIOS, run the batch file named "ami.bat" with the new BIOS ROM file from your bootable device or USB pen/thumb drive. Use the following format:

```
F:\> ami.bat BIOS-ROM-filename.xxx <Enter>
```

**Important:** Always use the file named "ami.bat" to update the BIOS, and insert a space between "ami.bat" and the filename. The BIOS-ROM-filename will bear the motherboard name (i.e., X9SRH) and build version as the extension. For example, "X9SRH1.218". When completed, your system will automatically reboot.

When the BIOS flashing screen is completed, the system will reboot and will show "Press F1 or F2". At this point, you will need to load the BIOS defaults. Press <F1> to go to the BIOS setup screen, and press <F9> to load the default settings. Next, press <F10> to save and exit. The system will then reboot.

**Warning:** Do not shut down or reset the system while updating the BIOS to prevent possible system boot failure!



**Note:** The SPI BIOS chip installed on this motherboard is not removable. To repair or replace a damaged BIOS chip, please send your motherboard to RMA at Supermicro for service.

**Question:** I think my BIOS is corrupted. How can I recover my BIOS?

**Answer:** Please see Appendix C-BIOS Recovery for detailed instructions.

**Question:** What's on the CD that came with my motherboard?

**Answer:** The supplied compact disc has quite a few drivers and programs that will greatly enhance your system. We recommend that you review the CD and install the applications you need. Applications on the CD include chipset drivers for Windows, security programs, and audio drivers.

**Question:** Why do I get an error message "IASTOR.SYS read error" and "press F6 to install Intel RAID driver" when installing Windows on my motherboard?

**Answer:** To solve this issue, disable the IPMI jumper. Another solution is to use a USB floppy drive instead of the onboard floppy drive. For the IPMI jumper location, please check Chapter 1.

**Question:** What is the heatsink part number for my X9SRH Series motherboard?

**Answer:** For the 1U passive heatsink, ask for SNK-P0046P (back plate is included). For the 2U active heatsink, use SNK-P0046A4.

**Question:** Why can't I recover the BIOS even when I've followed the instructions in the user's manual for the motherboard?

**Answer:** Please disable the IPMI jumper and try it again. For the jumper location, please check Chapter 1.

### 3-4 Battery Removal and Installation

#### Battery Removal

To remove the onboard battery, follow the steps below:

1. Power off your system and unplug your power cable.
2. Locate the onboard battery as shown below.
3. Using a tool such as a pen or a small screwdriver, push the battery lock outwards to unlock it. Once unlocked, the battery will pop out from the holder.
4. Remove the battery.

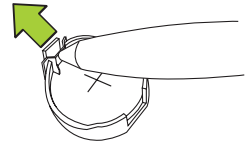
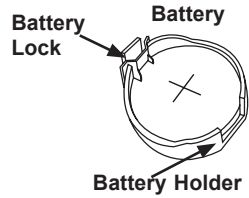

#### Proper Battery Disposal

**Warning:** Please handle used batteries carefully. Do not damage the battery in any way; a damaged battery may release hazardous materials into the environment. Do not discard a used battery in the garbage or a public landfill. Please comply with the regulations set up by your local hazardous waste management agency to dispose of your used battery properly.

#### Battery Installation

1. To install an onboard battery, follow the steps 1 & 2 above and continue below:
2. Identify the battery's polarity. The positive (+) side should be facing up.
3. Insert the battery into the battery holder and push it down until you hear a click to ensure that the battery is securely locked.

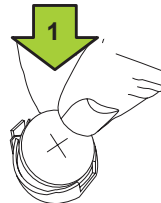
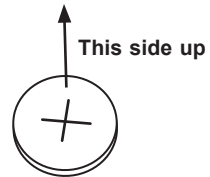

**Press down until you hear a click.**

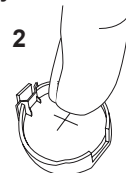

**Warning:** When replacing a battery, be sure to only replace it with the same type.

### **3-5 Returning Merchandise for Service**

A receipt or copy of your invoice marked with the date of purchase is required before any warranty service will be rendered. You can obtain service by calling your vendor for a Returned Merchandise Authorization (RMA) number. For faster service, you may also obtain RMA authorizations online (<http://www.supermicro.com/RmaForm/>). When you return the motherboard to the manufacturer, the RMA number should be prominently displayed on the outside of the shipping carton, and mailed prepaid or hand-carried. Shipping and handling charges will be applied for all orders that must be mailed when service is complete.

This warranty only covers normal consumer use and does not cover damages incurred in shipping or from failure due to the alteration, misuse, abuse or improper maintenance of products.

During the warranty period, contact your distributor first for any product problems.

## Notes

---

---

## Chapter 4

### BIOS

#### 4-1 Introduction

This chapter describes the AMI BIOS Setup Utility for the X9SRH Motherboard Series. The AMI ROM BIOS is stored in a Flash EEPROM and can be easily updated. This chapter describes the basic navigation of the AMI BIOS Setup Utility setup screens.



**Note:** For instructions on BIOS recovery, please refer to the instruction guide posted at <http://www.supermicro.com/support/manuals/>.

#### Starting BIOS Setup Utility

To enter the AMI BIOS Setup Utility screens, press the <Delete> key while the system is booting up.



**Note:** In most cases, the <Delete> key is used to invoke the AMI BIOS setup screen. There are a few cases when other keys are used, such as <F1>, <F2>, etc.

Each main BIOS menu option is described in this manual. The Main BIOS setup menu screen has two main frames. The left frame displays all the options that can be configured. Grayed-out options cannot be configured. Options in blue can be configured by the user. The right frame displays the key legend. Above the key legend is an area reserved for a text message. When an option is selected in the left frame, it is highlighted in white. Often a text message will accompany it. (**Note:** the AMI BIOS has default text messages built in. Supermicro retains the option to include, omit, or change any of these text messages.)

The AMI BIOS Setup Utility uses a key-based navigation system called "hot keys". Most of the AMI BIOS setup utility "hot keys" can be used at any time during the setup navigation process. These keys include <F3>, <F4>, <Enter>, <ESC>, arrow keys, etc.



**Note 1:** <F3> is used to load optimal default settings. <F4> is used to save the settings and exit the setup utility.

**Note 2:** Options printed in **Bold** are default settings.

## How To Change the Configuration Data

The configuration data that determines the system parameters may be changed by entering the AMI BIOS Setup utility. This Setup utility can be accessed by pressing <Del> at the appropriate time during system boot.

### How to Start the Setup Utility

Normally, the only visible Power-On Self-Test (POST) routine is the memory test. As the memory is being tested, press the <Delete> key to enter the main menu of the AMI BIOS Setup Utility. From the main menu, you can access the other setup screens. An AMI BIOS identification string is displayed at the left bottom corner of the screen, below the copyright message.

**Warning:** Do not upgrade the BIOS unless your system has a BIOS-related issue. Flashing the wrong BIOS can cause irreparable damage to the system. In no event shall Supermicro be liable for direct, indirect, special, incidental, or consequential damages arising from a BIOS update. If you have to update the BIOS, do not shut down or reset the system while the BIOS is updating. This is to avoid possible boot failure.

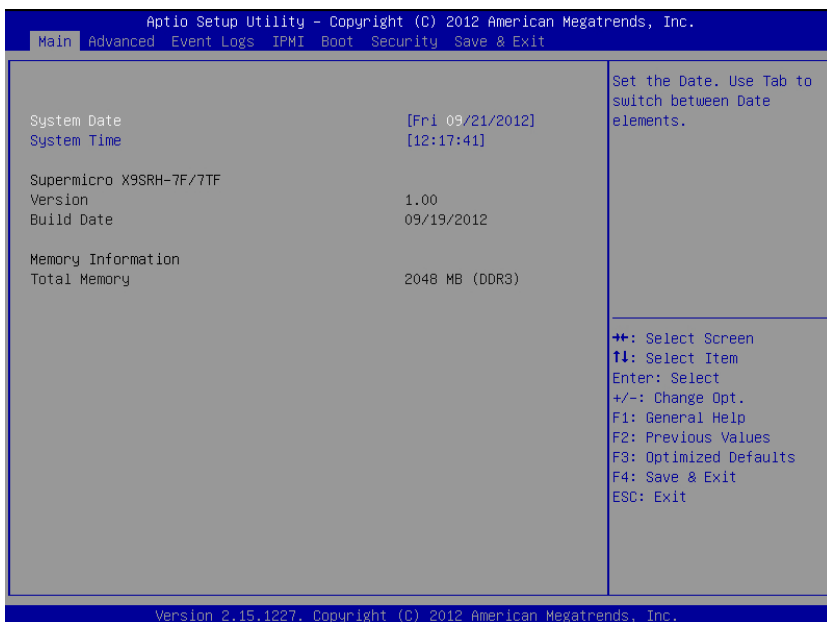

## 4-2 Main Setup

When you first enter the AMI BIOS Setup Utility, you will enter the Main setup screen. You can always return to the Main setup screen by selecting the Main tab on the top of the screen. The Main BIOS Setup screen is shown below.

**System Overview:** The following BIOS information will be displayed:

### **System Date/System Time**

Use this option to change the system time and date. Highlight *System Time* or *System Date* using the arrow keys. Enter new values through the keyboard. Press the <Tab> key or the arrow keys to move between fields. The date must be entered in Day MM/DD/YY format. The time is entered in HH:MM:SS format. (**Note:** The time is in the 24-hour format. For example, 5:30 P.M. appears as 17:30:00.)

### **Supermicro X9SRH-7F/7TF**

Version: This item displays the version of the BIOS used in the system.

Build Date: This item displays the day this version of BIOS was built.

### **Memory Information**

#### **Total Memory**

This displays the size of memory available in the system:

## 4-3 Advanced Setup Configurations

Use the arrow keys to select Boot Setup and hit <Enter> to access the submenu items:

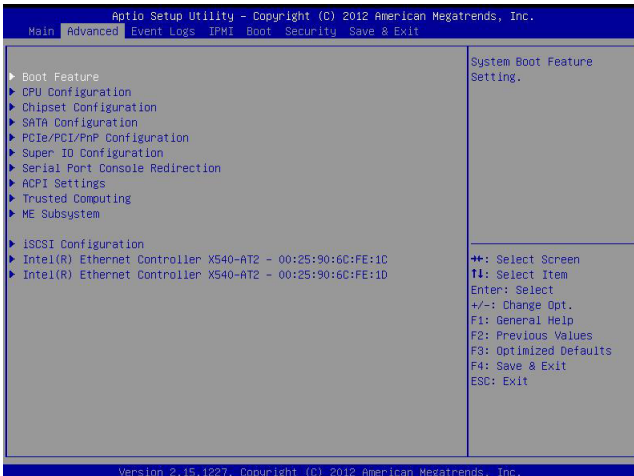

### ►BOOT Feature

#### Quiet Boot

This option allows the bootup screen options to be modified between POST messages or the OEM logo. Select Disabled to display the POST messages. Select Enabled to display the OEM logo instead of the normal POST messages. The options are **Enabled** and Disabled.

#### AddOn ROM Display Mode

This sets the display mode for Option ROM. The options are **Force BIOS** and Keep Current.

#### Bootup Num-Lock

This feature selects the Power-on state for Numlock key. The options are Off and **On**.

#### Wait For 'F1' If Error

This forces the system to wait until the 'F1' key is pressed if an error occurs. The options are Disabled and **Enabled**.

#### Interrupt 19 Capture

Interrupt 19 is the software interrupt that handles the boot disk function. When this item is set to Enabled, the ROM BIOS of the host adaptors will "capture" Interrupt

19 at boot and allow the drives that are attached to these host adaptors to function as bootable disks. If this item is set to Disabled, the ROM BIOS of the host adaptors will not capture Interrupt 19, and the drives attached to these adaptors will not function as bootable devices. The options are **Enabled** and Disabled.

### **Retry Boot**

If enabled, this feature will automatically retry to boot if the previous attempt fails. The options are Enabled and **Disabled**.

### **Watch Dog Function**

If enabled, the Watch Dog Timer will allow the system to reboot when it is inactive for more than 5 minutes. The options are Enabled and **Disabled**.

### **Power Button Function**

This feature controls how the system shuts down when the power button is pressed. Select 4-Seconds Override to force the user to press and hold the Power Button for 4 seconds before the system turns off. Select Instant Off if you want the system to instantly power off when the Power Button is pressed. The options are 4 Seconds Override and **Instant Off**.

### **Restore on AC Power Loss**

Use this feature to set the power state after a power outage. Select Power-Off for the system power to remain off after a power loss. Select Power-On for the system power to be turned on after a power loss. Select Last State to allow the system to resume its last state before a power loss. The options are Power-On, Stay-Off and **Last State**.

## **►CPU Configuration**

**Warning:** Take Caution when changing the Advanced settings. An incorrect value, a very high DRAM frequency or incorrect DRAM timing may cause system to become unstable. When this occurs, revert to the default setting.

### **►Socket 1 CPU Information**

This item is for informational purposes only and displays CPU information including type, speed, number of cores, etc.

### **Clock Spread Spectrum**

Select Enable to use the feature of Clock Spectrum, which will allow the BIOS to monitor and attempt to reduce the level of Electromagnetic Interference caused by the components whenever needed. Select Disabled to enhance system stability. The options are **Disabled** and Enabled.

### **Hyper Threading**

Set to Enabled to use the processor's Hyper Threading Technology feature. The options are **Enabled** and Disabled.

### **Active Processor Cores**

Set to Enabled to use a processor's Second Core and beyond. (Please refer to Intel's web site for more information.) The options are **All**, 1, 2, 4 and 6. **Note:** The options displayed here depends on the type of processor that is installed.

### **Limit CPUID Maximum**

This feature allows the user to set the maximum CPU ID value. Enable this function to boot the legacy operating systems that cannot support processors with extended CPUID functions. The options are Enabled and **Disabled** (for the Windows OS.).

### **Execute-Disable Bit (if supported by the OS and the CPU)**

Set to Enabled to enable the Execute Disable Bit which will allow the processor to designate areas in the system memory where an application code can execute and where it cannot, thus preventing a worm or a virus from flooding illegal codes to overwhelm the processor or damage the system during an attack. The default is **Enabled**. (Refer to Intel and Microsoft Web Sites for more information.)

### **Intel® AES-NI (If supported by the CPU)**

Set to Enabled to use the processor's Advanced Encryption Standard (AES) feature. The options are **Enabled** and Disabled.

### **MLC Streamer Prefetcher (if supported by the CPU)**

If set to Enabled, the hardware pre fetcher will pre fetch streams of data and instructions from the main memory to the L2 cache in the forward or backward manner to improve CPU performance. The options are Disabled and **Enabled**.

### **MLC Spatial Prefetch (if supported by the CPU)**

The CPU fetches the cache line for 64 bytes if this option is set to Disabled. The CPU fetches both cache lines for 128 bytes as comprised if **Enabled**.

### **DCU Streamer Prefetcher**

This feature enables prefetch of the next L1 data line based on multiple loads in the same cache line. The options are **Enabled** and Disabled.

### **DCU IP Prefetcher**

Set this feature to Enabled to activate the L1 Data Prefetcher based on sequential load history. The options are **Enabled** and Disabled.

---

---

### Intel® Virtualization Technology (if supported by the CPU)

Select Enabled to use the feature of Virtualization Technology to allow one platform to run multiple operating systems and applications in independent partitions, creating multiple "virtual" systems in one physical computer. The options are **Enabled** and Disabled.



**Note:** If there is any change to this setting, you will need to power off and restart the system for the change to take effect. Please refer to Intel's web site for detailed information.

### ► CPU Power Management Configuration

#### Power Technology

This feature determines what power-saving scheme the motherboard uses. The options are Disabled, **Energy Efficient** and Custom. If Custom is selected, the following options become available:

##### EIST

EIST (Enhanced Intel SpeedStep Technology) allows the system to automatically adjust processor voltage and core frequency in an effort to reduce power consumption and heat dissipation. **Please refer to Intel's web site for detailed information.** The options are Disabled and **Enabled**.

##### Turbo Mode (Available when EIST is set to Enabled)

This feature allows processor cores to run faster than marked frequency in specific conditions. The options are Disabled and **Enabled**.

##### C1E Support

Select Enabled to use the "Enhanced Halt State" feature. C1E significantly reduces the CPU's power consumption by reducing the CPU's clock cycle and voltage during a "Halt State." The options are Disabled and **Enabled**.

##### CPU C3 Report, CPU C6, CPU C7 Report

This BIOS feature enables or disables C3 (ACPI C2), C6 (ACPI C3), C7 (ACPI C3) reporting to the operating system. The options for C3 are **Disabled** and Enabled. The options for C6 and C7 are Disabled and **Enabled**.

##### Package C State Limit

If set to Auto, the AMI BIOS will automatically set the limit on the C-State package register. The options are C0, C2, **C6**, and No Limit.

### **Energy/Performance Bias**

This feature sets the optimization balance between performance and power savings. The options are Performance, **Balanced Performance**, Balanced Energy and Energy Efficient.

### **Long duration power limit**

This feature is the processor power consumption limit (in Watts) during a long duration time window.

### **Long duration maintained**

This feature is the time in milliseconds where the Long Duration Power Limit is maintained.

### **Short duration power limit**

During Turbo Mode, the system may exceed the processor's default power setting and exceed the Short Duration Power limit. By increasing this value, the processor can provide better performance for a short duration.

## **►Chipset Configuration**

**WARNING:** Setting the wrong values in the following sections may cause the system to malfunction.

### **►North Bridge Configuration**

This item displays the current IO chipset Revision.

#### **►Integrated IO Configuration**

##### **Intel® VT-d**

Select Enabled to enable Intel's Virtualization Technology support for Direct I/O VT-d by reporting the I/O device assignments to VMM through the DMAR ACPI Tables. This feature offers fully-protected I/O resource-sharing across the Intel platforms, providing the user with greater reliability, security and availability in networking and data-sharing. The settings are **Enabled** and Disabled.

##### **Intel® I/OAT**

The Intel I/O AT (I/O Acceleration Technology) significantly reduces CPU overhead by leveraging CPU architectural improvements, freeing resources for more other tasks. The options are Disabled and **Enabled**.

##### **DCA Support**

This feature accelerates the performance of I/O devices using Direct Cache Access. The options are **Enabled** and Disabled.

**MMCFG BASE**

This feature allows the user to specify a base address computation (for ACPI base address reporting) for regions that do not start at bus 0. The options are **0x80000000**, **0xA0000000**, and **0xC0000000**.

**IIO 1 PCIe Port Bifurcation Control****CPU1 Slot 3 PCI-E 3.0 x8 (in x16) Link Speed**

This feature enables the user to select the target link speed for this slot. The options are GEN1, GEN2 and **GEN3**.

**CPU1 Slot 6 PCI-E 3.0 x16 Link Speed**

This feature enables the user to select the target link speed for this slot. The options are GEN1, GEN2 and **GEN3**.

**► DIMM Configuration****Memory Configuration**

This section displays memory status such as Current Memory Mode, Memory Speed, Mirroring and Sparing information.

**► DIMM Information**

This feature displays information regarding the installed memory.

**Memory Mode**

The options are **Independent**, Mirroring, Lockstep and Sparing.

**Independent** - All DIMMs are available to the operating system.

**Mirroring** - The motherboard maintains two identical copies of all data in memory for redundancy.

**Lockstep** - The motherboard uses two areas of memory to run the same set of operations in parallel.

**Sparing** - Memory sparing occurs when on-demand inactive memory is automatically activated by the system to temporarily replace failed memory until a service action can be performed.



**Note:** The options may vary depending on the number of DIMMs installed per channel.

**DRAM RAPL Mode**

RAPL which stands for Running Average Power Limit is a feature that provides mechanisms to enforce power consumption limits on supported

processors The options are DRAM RAPL MODE0 , **DRAM RAPL MODE1**, and Disabled.

### **DDR Speed**

Use this option to force the system memory to run at a different frequency than the default frequency. The available options are **Auto**, Force DDR-800, Force DDR-1066, Force DDR-1333, Force DDR3-1600 and Force SPD.

### **Channel Interleaving**

This feature selects from the different channel memory interleaving methods. The options are **Auto**, 1 Way, 2 Way, 3 Way and 4 Way.

### **Rank Interleaving**

This feature selects from the different rank memory interleaving methods. The options are **Auto**, 1 Way, 2 Way, 3 Way, 4 Way and 8 Way.

### **Patrol Scrub**

Patrol Scrubbing is a process that allows the CPU to correct correctable memory errors detected on a memory module and send the correction to the requestor (the original source). When this item is set to Enabled, the North Bridge will read and write back one cache line every 16K cycles, if there is no delay caused by internal processing. By using this method, roughly 64 GB of memory behind the North Bridge will be scrubbed every day. The options are **Enabled** and Disabled.

### **Demand Scrub**

Demand Scrubbing is a process that allows the CPU to correct correctable memory errors found on a memory module. When the CPU or I/O issues a demand-read command, and the read data from memory turns out to be a correctable error, the error is corrected and sent to the requestor (the original source). Memory is updated as well. Select Enabled to use Demand Scrubbing for ECC memory correction. The options are Enabled and **Disabled**.

### **Data Scrambling**

This feature enables Data Scrambling. The options are **Enabled** and Disabled.

### **Device Tagging**

This feature enables Device Tagging. The options are Enabled and **Disabled**.

### **Thermal Throttling**

This feature selects from the different throttling methods. The options are Disabled and **CLTT** (Closed Loop Thermal Throttling).

### **►South Bridge Configuration**

This item displays the current South Bridge Revision.

#### **All USB Devices**

This feature enables all USB ports/devices. The options are **Enabled** and Disabled.

#### **EHCI Controller 1 / EHCI Controller 2**

This feature enables the Enhanced Host Controller Interface (EHCI). The options are **Enabled** and Disabled.

#### **Legacy USB Support**

This feature enables support for legacy USB devices. Select Auto to disable legacy support if USB devices are not present. Select Disable to have USB devices available only for EFI applications. The options are **Enabled**, Disabled and Auto.

#### **Port 60/64 Emulation**

This feature enables I/O port 60h/64h emulation support. This should be enabled for complete USB keyboard legacy support for non-USB aware Operating Systems. The options are **Enabled**, and Disabled.

#### **EHCI Hand-Off**

This item is for Operating Systems that does not support Enhanced Host Controller Interface (EHCI) hand-off. When enabled, EHCI ownership change will be claimed by the EHCI driver. The settings are Enabled and **Disabled**.

### **►SATA Configuration**

When this submenu is selected, the AMI BIOS automatically detects the presence of the IDE Devices and displays the following items:

#### **SATA Port0~Port5**

This item displays the information detected on the installed SATA drives on the particular SATA port.

## **SATA Mode**

This item selects the mode for the installed drives. The options are Disabled, IDE Mode, **AHCI Mode** and RAID Mode. The following are displayed depending on your selection:

### **IDE Mode**

The following items are displayed when IDE Mode is selected:

#### **Serial-ATA Controller 0~1**

This feature is used to activate/deactivate the SATA controller, and sets the compatibility mode. The options for Serial-ATA Controller 0 are Disabled, Enhanced and **Compatible**. The options for Serial-ATA Controller 1 are Disabled and **Enhanced**.

### **AHCI Mode**

The following items are displayed when AHCI Mode is selected:

#### **Aggressive Link Power Management**

When Enabled, the SATA AHCI controller manages the power usage of the SATA link. The controller will put the link in a low power mode during extended periods of I/O inactivity, and will return the link to an active state when I/O activity resumes. The options are **Enabled** and Disabled.

#### **Port 0~5 Hot Plug**

Set this item to Enabled to enable hot-plugging for the particular port. The options are **Enabled** and Disabled.

#### **Port 0~5 Staggered Spin Up**

Set this item to Enabled to enable Staggered Spin-up support. The options are Enabled and **Disabled**.

### **RAID Mode**

The following items are displayed when RAID Mode is selected:

#### **SATA RAID Option ROM/UEFI Driver**

Use this feature to enable the onboard SATA Option ROM or EFI driver. The options are **Enabled** and Disabled.

#### **Port 0~5 Hot Plug**

Set this item to Enabled to enable hot-plugging for the particular port. The options are **Enabled** and Disabled.

---

---

## ►PCIe/PCI/PnP Configuration

This feature allows the user to set the PCI/PnP configurations for the following items:

### Launch Storage OpROM Policy

In case of multiple Option ROMs (Legacy and UEFI-compatible), this feature specifies what ROM to launch. The options are **Legacy Only** and UEFI Only.

### PCI Latency Timer

This feature sets the latency Timer of each PCI device installed on a PCI bus. Select 64 to set the PCI latency to 64 PCI clock cycles. The options are 32 PCI Bus Clocks, **64 PCI Bus Clocks**, 96 PCI Bus Clocks, 128 PCI Bus Clocks, 160 PCI Bus Clocks, 192 PCI Bus Clocks, 224 PCI Bus Clocks and 248 PCI Bus Clocks.

### PERR# Generation

Set this item to Enabled to allow PCI devices to generate PERR# error codes. The options are Enabled and **Disabled**.

### SERR# Generation

Set this item to Enabled to allow PCI devices to generate SERR# error codes. The options are Enabled and **Disabled**.

### Maximum Payload

This feature selects the setting for the PCIe maximum payload size. The options are **Auto**, 128 Bytes, and 256 Bytes.

### Maximum Read Request

This feature selects the setting for the PCIe maximum Read Request size. The options are **Auto**, 128 Bytes, 256 Bytes, 512 Bytes, 1024 Bytes, 2048 Bytes, and 4096 Bytes.

### ASPM Support

Set this item to the desired ASPM (Active State Power Management) level. The options are **Disabled**, Auto and Force L0s.

### Above 4G Decoding

Set this item to Enabled to activate 64-bit capable devices to be decoded above the 4G address space. This works only if the system supports 64-bit PCI decoding. The options are Enabled and **Disabled**.

**Slot1 PCI 33MHZ OPROM**  
**Slot2 PCI 33MHZ OPROM**  
**CPU1 Slot3 PCI-E 3.0 x8 (in x16) OPROM**  
**Slot4 PCI 33MHZ OPROM (X9SRH-7F only)**  
**PCH Slot5 PCI-E 2.0 x4 OPROM**  
**CPU1 Slot6 PCI-E 3.0 x16 OPROM**

Use this feature to enable or disable PCI-E slot Option ROMs. The options are Disabled and **Enabled**.

#### **Onboard LAN Option ROM Select**

This feature selects whether to load the iSCSI or PXE onboard LAN option ROM. The options are iSCSI and **PXE**.

#### **Load Onboard LAN1 Option ROM / Load Onboard LAN2 Option ROM**

This feature is to enable or disable the onboard option ROMs. The options are Disabled and Enabled. The default for LAN 1 is **Enabled**. Default for LAN 2 is **Disabled**.

#### **VGA Priority**

This option allows the user to specify which graphics controller to be used as the primary boot device. The options are **Onboard** and Offboard.

#### **Network Stack**

Use this feature to enable or disable the network stack (PXE and UEFI). The options are **Disabled** and Enabled.

#### **IPv4 PXE Support (Available when Network Stack is set to Enabled)**

Set this item to Enabled to activate IPv4 PXE Support. The options are **Enabled** and Disabled.

### **► Super IO Device Configuration**

#### **► Serial Port 1 Configuration / Serial Port 2 Configuration**

##### **Serial Port 1 / Serial Port 2**

Select Enabled to enable the onboard serial port. The options are **Enabled** and Disabled.

##### **Serial Port 1 Settings / Serial Port 2 Settings**

This option specifies the base I/O port address and the Interrupt Request address of Serial Port 1 and Serial Port 2. Select Disabled to prevent the serial port from accessing any system resources. When this option is set to Disabled, the serial port becomes unavailable.

The options for Serial Port 1 are:

**Auto,**

IO=3F8h; IRQ=4;

IO=3F8h; IRQ=3, 4, 5, 6, 7, 9, 10, 11, 12;

IO=2F8h; IRQ=3, 4, 5, 6, 7, 9, 10, 11, 12;

IO=3E8h; IRQ=3, 4, 5, 6, 7, 9, 10, 11, 12;

IO=2E8h; IRQ=3, 4, 5, 6, 7, 9, 10, 11, 12;

The options for Serial Port 2 are:

**Auto,**

IO=2F8h; IRQ=3;

IO=3F8h; IRQ=3, 4, 5, 6, 7, 9, 10, 11, 12;

IO=2F8h; IRQ=3, 4, 5, 6, 7, 9, 10, 11, 12;

IO=3E8h; IRQ=3, 4, 5, 6, 7, 9, 10, 11, 12;

IO=2E8h; IRQ=3, 4, 5, 6, 7, 9, 10, 11, 12;

**►Serial Port Console Redirection****COM1, COM2, or SOL Console Redirection**

Use this feature to enable console redirection for COM1, COM2, and SOL ports. The options are Enabled and Disabled. The default for COM1 and COM2 is **Disabled**. The default for SOL is **Enabled**.

**►Console Redirection Settings**

Configure the following options for the Console Redirection Settings. The most common settings are set as default:

Terminal Type : Select ANSI, VT100, **VT100+**, or VT-UTF8Bits per Second (BPS): 9600, 19200, 38400, 57600, or **115200**Data Bits: **8** or 7Parity: **None**, Even, Odd, Mark, or SpaceStop Bits: **1** or 2Flow Control: **None** or Hardware RTS/CTSVT-UTF8 Combo Key Support: **Enabled** or DisabledRecorder Mode: **Disabled** or Enabled

Resolution 100x31: Disabled or **Enabled**

Legacy OS Redirection Resolution: 80x24 or **80x25**

PuTTY Keypad: **VT100**, Linux, XTerm86, SCO, ESCN, VT400

Redirection After BIOS POST: **Always Enable**, Bootloader

### **Serial Port for Out-of-Band Management / Windows Emergency Management Services (EMS)**

Use this feature to enable console redirection.

#### **EMS Console Redirection**

Use this feature to enable console redirection for Serial Port Out-of-Band Management / Windows Emergency Management Services (EMS) ports. The options are Enabled and **Disabled**.

##### **► Console Redirection Settings**

Configure the following options for the Console Redirection Settings. The most common settings are set as default:

Out-of-Band Mgmt Port: **COM1**, COM2, and SOL

Terminal Type: Select ANSI, VT100, **VT100+**, or VT-UTF8

Bits per Second (BPS): 9600, 19200, 57600, or **115200**

Flow Control: **None**, Hardware RTS/CTS, Software Xon/Xoff

Data Bits: **8** or 7

Parity: **None**, Even, Odd, Mark, or Space

Stop Bits: **1** or 2

##### **► ACPI Settings**

Use this feature to configure Advanced Configuration and Power Interface (ACPI) power management settings for your system.

#### **ACPI Sleep State**

This setting allows you to configure the ACPI (Advanced Configuration and Power Interface) sleep state for your system when it is in the Suspend mode. The options are Suspend Disabled, **S1 (CPU Stop Clock)**.

#### **High Precision Event Timer**

Select Enabled to activate the High Performance Event Timer (HPET) that produces periodic interrupts at a much higher frequency than a Real-time Clock (RTC) does in

---

synchronizing multimedia streams, providing smooth playback and reducing the dependency on other timestamp calculation devices, such as an x86 RDTSC Instruction embedded in the CPU. The High Performance Event Timer is used to replace the 8254 Programmable Interval Timer. The options are **Enabled** and Disabled.

## ►Trusted Computing

### TPM Support (if a TPM device is installed)

Select Enable to activate support for trusted platforms (TPM 1.1/1.2) and allow the BIOS to automatically download the drivers needed to provide support for the platforms specified. The options are **Enable** and Disable.

### TPM State

This feature enables or disables the installed security device. The options are Enabled and **Disabled**.

### Pending Operation

This section will display any operation that is pending. Any of the following messages are displayed: **None**, Enable Take Ownership, Disable Take Ownership and TPM clear.

If TPM Support is set to Enable, the TPM Status will appear:

**TPM Enabled Status** - any of the following status messages are shown:  
Enabled or Disabled.

**TPM Active Status** - any of the following status messages are shown:  
Activated or Deactivated.

**TPM Owner Status**- any of the following status messages are shown:  
Owned or Unowned.

## ►Intel TXT(LT-SX) Configuration

### CPU/Chipset TXT Feature

This section appears if the TXT Feature is supported by the CPU and/or chipset.

### TXT Support

Intel TXT (Trusted Execution Technology) helps protect against software-based attacks and ensures protection, confidentiality and integrity of data stored or created on the system. The options are Enabled and **Disabled**.

### Intel TXT(LT-SX) Dependencies

This section displays any features that must be enabled/supported on the motherboard prior to enabling Intel TXT.

## ►ME Subsystem

This item displays the ME Subsystem information.

## ►iSCSI Configuration

When sharing the iSCSI devices on this machine (iSCSI target), this section is used to enter the worldwide unique name of an iSCSI initiator. An iSCSI initiator application must be configured on the machine that will access the iSCSI drives in this machine. **Note:** This section will only appear if the Intel iSCSI driver is integrated into the BIOS..

### iSCSI Initiator Name

Only IQN (iSCSI Qualified Names) names are accepted. Please research RFC 3720 and RFC 3721 at the Internet Engineering Task Force website (IETF -- [www.ietf.org](http://www.ietf.org)) for more information on iSCSI.

### Add an Attempt

The settings on this section are setup parameters to connect to a remote iSCSI device.

**iSCSI Attempt Name** - assigns a unique name to this attempt.

**iSCSI Mode** - select Enabled or **Disabled**.

**Internet Protocol** - select **IP4**, **IP6** or **Autoconfigure**.

**Connection Retry Count** - if the initial connection fails or times out, this is how many times an attempt will be made to connect.

**Connection Establishing Timeout** - This is the time in milliseconds the system will wait for a connection until it times out. The minimum is 100ms and the maximum is 20 secs.

**ISID** - This is the OUI-format ISID. The default value is taken from the device's MAC address. Only the last 3 bytes are configurable.

**Enable DHCP** - Select Enabled to allow a DHCP server to assign the IP addresses for this attempt. If this is set to **Disabled**, then you need to manually enter the Initiator IP Address, Initiator Subnet Mask and Gateway.

**Get target info via DHCP** - select Enabled to allow the system to retrieve the target device information through the DHCP server. The options are Enabled and **Disabled**

**Target Name** - Enter the qualified domain name of the target iSCSI device.

**Target IP Address** - Enter the IP Address of the target iSCSI device.

**Target Port** - Enter the port address of the target iSCSI device.

**Boot LUN** - This is the target's LU number in Hexadecimal format.

**Authentication Type** - Select **CHAP** or None.

If CHAP is selected above:

**CHAP Type** - Select **One Way** or Mutual.

**CHAP Name** - Assign a name for this authentication.

**CHAP Secret** - Assign a secret word that is also defined in the target iSCSI device. Minimum length is 12 bytes and maximum is 16 bytes.

When finished, select Save Changes and select Back to Previous Page.

### **Delete Attempts**

This feature deletes previously defined attempts as above.

### **Change Attempt Order**

This feature changes the order in which several iSCSI connection attempts are made.

### **Intel(R) Intel Ethernet Controller X540-AT2/**

### **Intel(R) Intel Ethernet Controller X540-AT2**

#### **NIC Configuration**

##### **Link Speed**

Use this feature to select the link speed to be used. The options are **AutoNeg**, 10 Mbps Half, 10 Mbps Full, 100 Mbps Half and 100 Mbps Full.

##### **Wake On LAN**

Use this feature to activate the Wake On LAN (WOL) feature. The options are Enabled, and Disabled.

##### **Blink LEDs (Range 0-15 seconds)**

Please specifies the blink rate of the NIC LED. Select from 1-15 second intervals.

##### **Port Configuration Information**

This section displays the current configuration of the Network Interface.

## 4-4 Event Logs

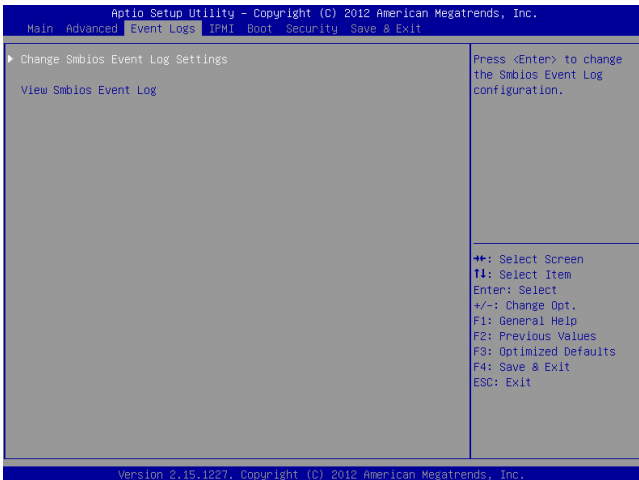

### ►Change SmbIOS Event Log Settings

#### Smbios Event Log

Change this item to enable or disable all features of the Smbios Event Logging during boot. The options are **Enabled** and Disabled.

#### Runtime Error Logging Support

Change this item to enable or disable runtime error logging. The options are **Enabled** and Disabled.

#### Memory Correction Error Threshold

Change this item to define the system's memory correction error threshold. Directly enter a numeric value. The default value is **10**.

#### PCI Error Logging Support

Change this item to enable or disable runtime error logging. The options are Enabled and **Disabled**.

#### Erase Event Log

This option erases all logged events. The options are **No**, Yes, Next reset and Yes, Every reset.

#### When Log is Full

This option automatically clears the Event Log memory of all messages when it is full. The options are **Do Nothing** and Erase Immediately.

**Log System Boot Event**

This option toggles the System Boot Event logging to enabled or disabled. The options are **Disabled** and Enabled.

**MECI**

The Multiple Event Count Increment (MECI) counter counts the number of occurrences a duplicate event must happen before the MECI counter is incremented. This is a numeric value. The default value is **1**.

**METW**

The Multiple Event Time Window (METW) defines number of minutes must pass between duplicate log events before MECI is incremented. This is in minutes, from 0 to 99. The default value is **60**.

**View SmbIOS Event Log**

This feature displays the contents of the SmbIOS Event Log.

## 4-5 IPMI

Intelligent Platform Management Interface (IPMI) is a set of common interfaces that IT administrators can use to monitor system health and to manage the system as a whole. For more information on the IPMI specifications, please visit Intel's website at [www.intel.com](http://www.intel.com).

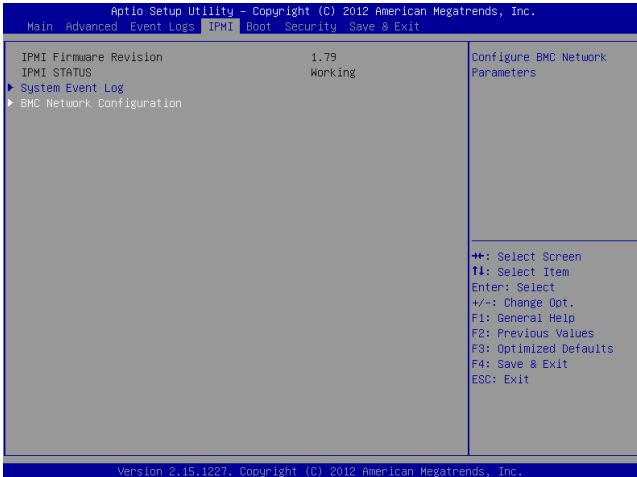

### ►System Event Log

This feature is used to change the System Event Log (SEL) configuration.

**SEL Components** - Change this item to enable or disable all features of System Event Logging. The options are **Enabled** and Disabled. When Enabled, the following can be configured:

**Erase SEL** - This option erases all logged SEL events. The options are **No**, Yes, On Next reset and Yes, On Every reset.

#### When SEL is Full

This option automatically clears the System Event Log memory of all messages when it is full. The options are **Do Nothing** and Erase Immediately.

### ►BMC Network Configuration

Set this feature to configure the IPMI LAN adapter with a network address.

#### Update IPMI LAN Configuration

This feature allows the user to decide if the BIOS should configure the IPMI setting at next system boot. The options are **No** and Yes. If the option is set to Yes, the user is allowed to configure the IPMI settings at next system boot.

### Configuration Address Source

This feature selects whether the IP address, Subnet Mask and Gateway Address are automatically assigned by the network's DHCP server (Dynamic Host and Configuration Protocol) "Dynamic" or manually entered by the user "Static". If Static is selected, the IP Address, Subnet Mask and Gateway Address must be manually entered below. When Dynamic is selected, all the options below are automatically assigned to the system by itself or by an external DHCP server.

The options are Static and **DHCP**. The following items are displayed when Static is selected:

**Station IP Address** - Enter the IP address for this machine. This should be in decimal and in dotted quad form (i.e., 192.168.10.253). The value of each three-digit number separated by dots should not exceed 255.

**Subnet Mask** - Subnet masks tell the network which subnet this machine belongs to. The value of each three-digit number separated by dots should not exceed 255.

**Station MAC Address** - MAC addresses are 6 two-digit hexadecimal numbers (Base 16, 0 ~ 9, A, B, C, D, E, F) separated by dots (i.e., 00.30.48.D0.D4.60).

**Gateway IP Address** - Enter the Gateway or Router address this machine will use (i.e., 192.168.10.1).

## 4-6 Boot Settings

Use this feature to configure Boot Settings:

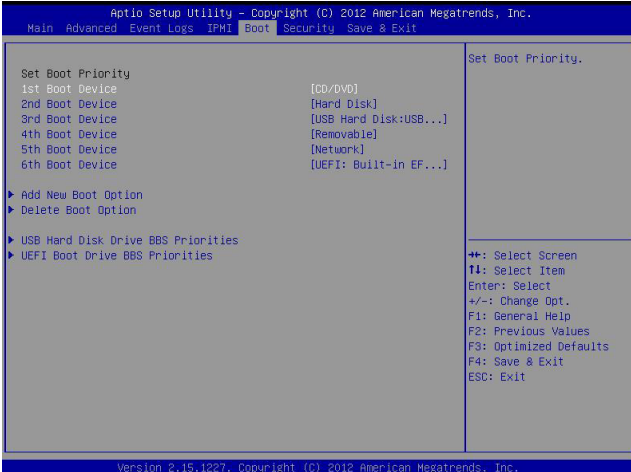

### Set Boot Priority

#### 1st Boot Device, 2nd Boot Device, 3rd Boot Device, etc.

Use these items to specify the sequence of boot device priority.

#### ►Add Boot Option

This feature appears if the BIOS detects UEFI-capable devices. This allows the user to define a boot device from which the systems boots during startup.

**Add Boot Option** - Specifies the name of the new boot option

**Path for boot option** - the path to the boot option in the format fsx:\path\filename.efi

**Create** - Choose this after defining both above to create the boot option.

#### ►Delete Boot Option

This feature allows the user to delete a previously defined boot device from which the systems boots during startup.

The options are **Built-in EFI Shell**, and [any other pre-defined boot device]

#### Network Devices, USB Device BBS Priorities, Hard Disk Drives

The above options appear when detected by the BIOS. Use these options to set the order of the legacy network, USB, and Hard Disk Drive devices detected.

## 4-7 Security Settings

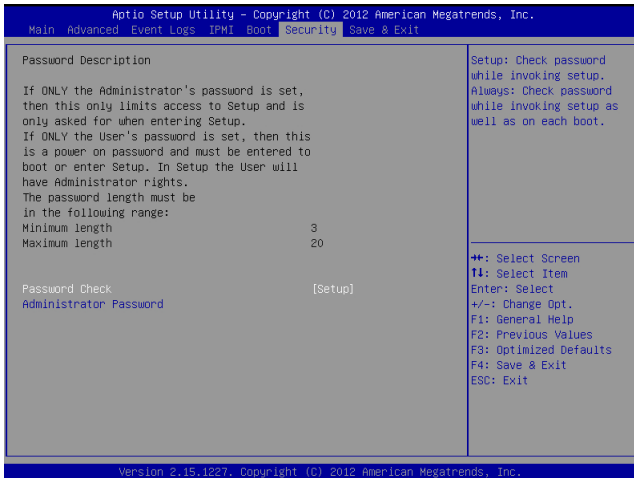

### Password Check

Use this feature to determine when a password entry is required. Select Setup to require the password only when entering setup. Select Always to require the password when entering setup and on each boot. The options are **Setup** and Always.

### Administrator Password

Use this feature to set the Administrator Password which is required to enter the BIOS setup utility. The length of the password should be from 3 characters to 20 characters long.

## 4-8 Save & Exit

Select the Exit tab from the BIOS Setup Utility screen to enter the Exit BIOS Setup screen.

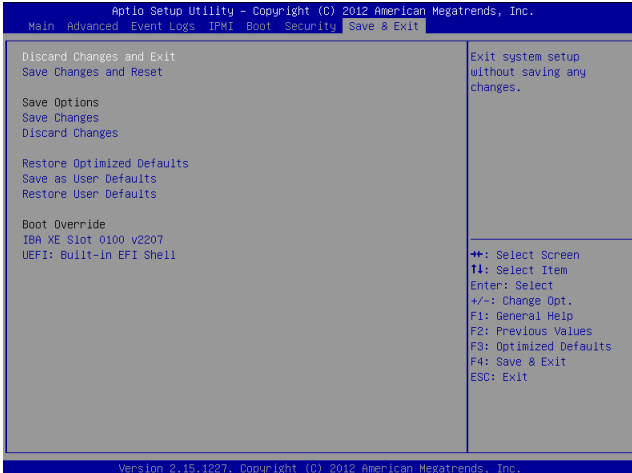

### Discard Changes and Exit

Select this option to quit the BIOS Setup without making any permanent changes to the system configuration, and reboot the computer. Select Discard Changes and Exit from the Exit menu and press <Enter>.

### Save Changes and Reset

When you have completed the system configuration changes, select this option to leave the BIOS Setup Utility and reboot the computer, so the new system configuration parameters can take effect. Select Save Changes and Exit from the Exit menu and press <Enter>.

### Save Changes

When you have completed the system configuration changes, select this option to save any changes made. This will not reset (reboot) the system.

### Discard Changes

Select this option and press <Enter> to discard all the changes and return to the AMI BIOS Utility Program.

### **Restore Optimized Defaults**

To set this feature, select Restore Defaults from the Exit menu and press <Enter>. These are factory settings designed for maximum system stability, but not for maximum performance.

### **Save As User Defaults**

To set this feature, select Save as User Defaults from the Exit menu and press <Enter>. This enables the user to save any changes to the BIOS setup for future use.

### **Restore User Defaults**

To set this feature, select Restore User Defaults from the Exit menu and press <Enter>. Use this feature to retrieve user-defined settings that were saved previously.

### **Boot Override**

This feature allows the user to override the Boot Option Priorities setting in the Boot menu, and instead immediately boot the system with one of the listed devices. This is a one-time override.

## Notes

---

---

## Appendix A

### BIOS Error Beep Codes

During the POST (Power-On Self-Test) routines, which are performed each time the system is powered on, errors may occur.

**Non-fatal errors** are those which, in most cases, allow the system to continue with bootup. The error messages normally appear on the screen.

**Fatal errors** will not allow the system to continue to bootup. If a fatal error occurs, you should consult with your system manufacturer for possible repairs.

These fatal errors are usually communicated through a series of audible beeps. The numbers on the fatal error list correspond to the number of beeps for the corresponding error.

#### A-1 BIOS Error Beep Codes

BIOS Error Beep Codes		
Beep Code/LED	Error Message	Description
1 beep	Refresh	Circuits have been reset. (Ready to power up)
5 short beeps + 1 long beep	Memory error	No memory detected in the system
5 beeps	Display memory read/write error	Video adapter missing or with faulty memory
OH LED On	System OH	System Overheat

## Notes

## Appendix B

### Software Installation Instructions

#### B-1 Installing Drivers

After you've installed the Windows Operating System, a screen as shown below will appear. You are ready to install software programs and drivers that have not yet been installed. To install these software programs and drivers, click the icons to the right of these items. (**Note:** To install the Windows Operating System, please refer to the instructions posted on our website at <http://www.supermicro.com/support/manuals/>.)

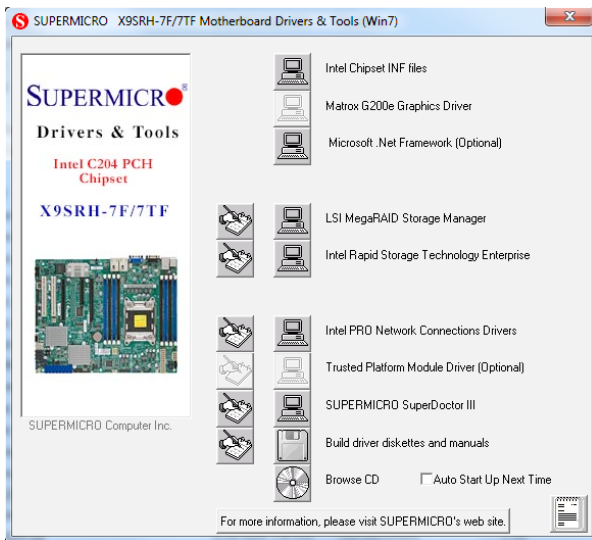

#### Driver/Tool Installation Display Screen



**Note 1:** Click the icons showing a hand writing on the paper to view the readme files for each item. Click on a computer icon to the right of an item to install this item (from top to the bottom), one at a time. After installing each item, you must reboot the system before proceeding with the next item on the list. The bottom icon with a CD on it allows you to view the entire contents of the CD.

**Note 2:** When making a storage driver diskette by booting into a Driver CD, please set the SATA Configuration to "Compatible Mode" and configure SATA as IDE in the BIOS Setup. After making the driver diskette, be sure to change the SATA settings back to your original settings.

## B-2 Configuring SuperDoctor<sup>®</sup> III

The SuperDoctor III program is a Web-based management tool that supports remote management capability. It includes Remote and Local Management tools. The local management tool is called the SD III Client. The SuperDoctor III program included on the CDROM that came with your motherboard allows you to monitor the environment and operations of your system. SuperDoctor III displays crucial system information such as CPU temperature, system voltages and fan status. See the Figure below for a display of the SuperDoctor III interface.



**Note 1:** The default user name and password are ADMIN.

**Note 2:** In the Windows OS environment, the SuperDoctor III settings take precedence over the BIOS settings. When first installed, SuperDoctor III adopts the temperature threshold settings previously set in BIOS. Any subsequent changes to these thresholds must be made within SuperDoctor, since the settings override the BIOS settings. For the Windows OS to adopt the BIOS temperature threshold settings, please change the SD III Client settings to be the same as those set in BIOS.

### SuperDoctor<sup>®</sup> III Interface Display Screen-I (Health Information)

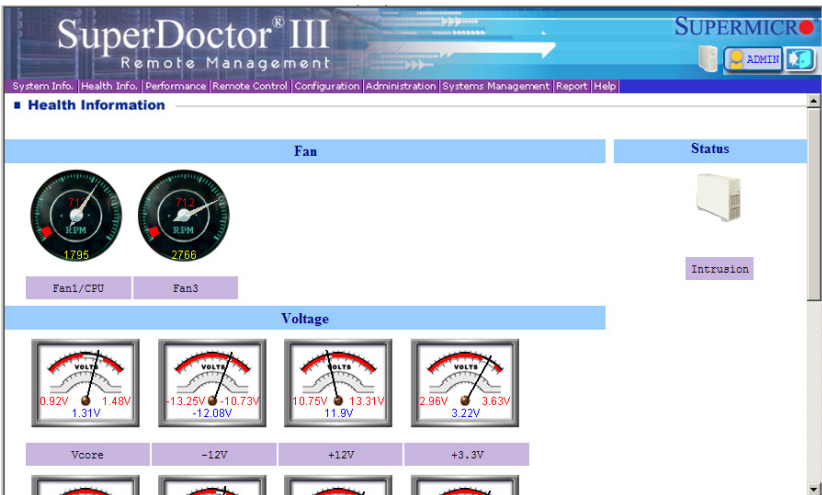

**SuperDoctor® III Interface Display Screen-II (Remote Control)**

**Remote Control**

**Graceful power control (cancelable)**

Super Doctor III allows a user to inform the OS to reboot or shut down the system within 30 seconds. On the system console, a pop-up window will appear with a message telling the local user to save his working files. Before the system reboots or shuts down, it's allowed to cancel the action either locally or remotely.

**Power control (noncancelable)**

Super Doctor III allows a user to inform the OS to reboot or shut down the system right away. The system will reboot or shut down without any warning messages. It's not allowed to cancel the action.



**Note:** The SuperDoctor III software and manual may be downloaded from our Website at:

<http://www.supermicro.com/products/accessories/software/SuperDoctorIII.cfm>.

For Linux, we still recommend that you use SuperDoctor II, this version is also available for download at the link above.

## Notes

## Appendix C

### UEFI BIOS Recovery Instructions

**Warning!** Do not upgrade the BIOS unless your system has a BIOS-related issue. Flashing the wrong BIOS can cause irreparable damage to the system. In no event shall Supermicro be liable for direct, indirect, special, incidental, or consequential damages arising from a BIOS update. If you need to update the BIOS, do not shut down or reset the system while the BIOS is updating to avoid possible boot failure.

#### An Overview to the UEFI BIOS

The Unified Extensible Firmware Interface (UEFI) specification provides a software-based interface between the operating system and the platform firmware in the pre-boot environment. The UEFI specification supports an architecture-independent mechanism for add-on card initialization to allow the UEFI OS loader, which is stored in the add-on card, to boot up the system. UEFI offers a clean, hand-off control to a computer system at bootup.

#### How to Recover the UEFI BIOS Image (the Main BIOS Block)

An AMIBIOS flash chip consists of a boot sector block and a main BIOS code block (a main BIOS image). The boot sector block contains critical BIOS codes, including memory detection and recovery codes for the user to flash a new BIOS image if the original BIOS image is corrupted. When the system power is on, the boot sector codes execute first. Once it is completed, the main BIOS code will continue with system initialization and bootup.



**Note:** Follow the BIOS Recovery instructions below for BIOS recovery when the main BIOS block crashes. However, when the BIOS Boot sector crashes, you will need to send the motherboard back to Supermicro for RMA repair.

#### To Recover the Main BIOS Block Using a USB-Attached Device

This feature allows the user to recover a BIOS image using a USB-attached device without additional utilities used. A USB flash device such as a USB Flash Drive, or a USB CD/DVD ROM/RW device can be used for this purpose. However, a USB Hard Disk drive cannot be used for BIOS recovery at this time.

To perform UEFI BIOS recovery using a USB-attached device, follow the instructions below.

1. Using a different machine, copy the "Super.ROM" binary image file into the disc Root "\\" Directory of a USB device or a writeable CD/DVD.



**Note:** If you cannot locate the "Super.ROM" file in your driver disk, visit our website at [www.supermicro.com](http://www.supermicro.com) to download the BIOS image into a USB flash device and rename it to "Super.ROM" for BIOS recovery use.

2. Insert the USB device that contains the new BIOS image ("Super.Rom") into your USB drive and power on the system
3. While powering on the system, keep pressing <Ctrl> and <Home> simultaneously on your PS2 or USB keyboard until you hear two short beeps. This may take from a few seconds to one minute.
4. After locating the new BIOS binary image, the system will enter the BIOS Recovery page as shown below.

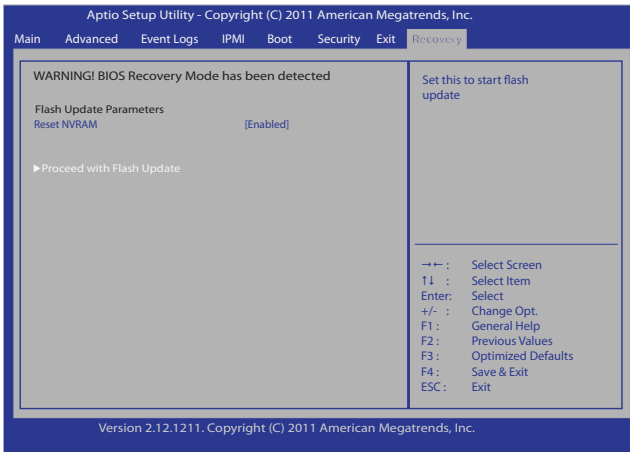

**Note:** At this point, you may decide if you want to start with BIOS Recovery. If you decide to proceed with BIOS Recovery, follow the procedures below.

5. When the screen as shown above displays, using the arrow key, select the item- "Proceed with flash update" and press the <Enter> key. You will see the progress of BIOS Recovery as shown in the screen below.

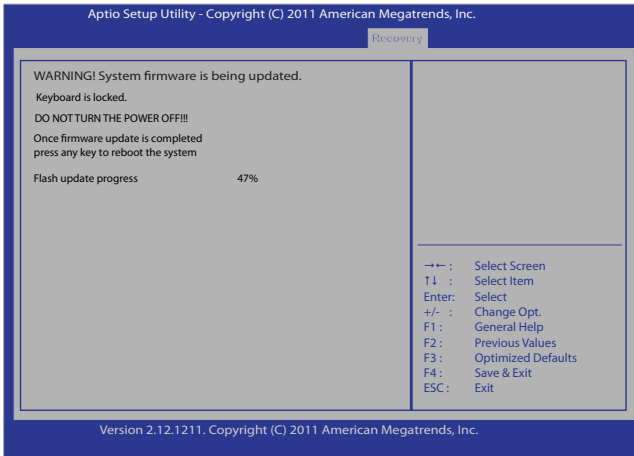

**Note:** Do not interrupt the process of BIOS flashing until it is completed.

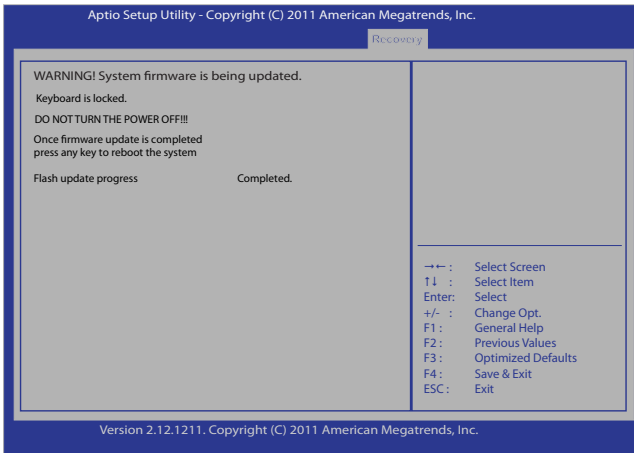

6. After the process of BIOS Recovery is complete, press any key to reboot the system.
7. Using a different system, extract the BIOS package into a bootable USB flash drive.

8. When a DOS prompt appears, type AMI.BAT BIOSname.### at the prompt.



**Note:** Do not interrupt this process until BIOS flashing is completed.

9. After seeing the message that BIOS update is completed, unplug the AC power cable to clear CMOS, and then plug in the AC power cable to power on the system.
10. Press <Del> continuously to enter the BIOS Setup utility.
11. Press <F3> to load default settings.
12. After loading default settings, press <F4> to save the settings and exit the BIOS Setup utility.

(Disclaimer Continued)

The products sold by Supermicro are not intended for and will not be used in life support systems, medical equipment, nuclear facilities or systems, aircraft, aircraft devices, aircraft/emergency communication devices or other critical systems whose failure to perform be reasonably expected to result in significant injury or loss of life or catastrophic property damage. Accordingly, Supermicro disclaims any and all liability, and should buyer use or sell such products for use in such ultra-hazardous applications, it does so entirely at its own risk. Furthermore, buyer agrees to fully indemnify, defend and hold Supermicro harmless for and against any and all claims, demands, actions, litigation, and proceedings of any kind arising out of or related to such ultra-hazardous use or sale.