



# X10QBL-4CT X10QBL-4

USER'S MANUAL

Revision 1.0

---

The information in this user's manual has been carefully reviewed and is believed to be accurate. The vendor assumes no responsibility for any inaccuracies that may be contained in this document, and makes no commitment to update or to keep current the information in this manual, or to notify any person or organization of the updates. **Please Note: For the most up-to-date version of this manual, please see our website at [www.supermicro.com](http://www.supermicro.com).**

Super Micro Computer, Inc. ("Supermicro") reserves the right to make changes to the product described in this manual at any time and without notice. This product, including software and documentation, is the property of Supermicro and/or its licensors, and is supplied only under a license. Any use or reproduction of this product is not allowed, except as expressly permitted by the terms of said license.

IN NO EVENT WILL SUPER MICRO COMPUTER, INC. BE LIABLE FOR DIRECT, INDIRECT, SPECIAL, INCIDENTAL, SPECULATIVE OR CONSEQUENTIAL DAMAGES ARISING FROM THE USE OR INABILITY TO USE THIS PRODUCT OR DOCUMENTATION, EVEN IF ADVISED OF THE POSSIBILITY OF SUCH DAMAGES. IN PARTICULAR, SUPER MICRO COMPUTER, INC. SHALL NOT HAVE LIABILITY FOR ANY HARDWARE, SOFTWARE, OR DATA STORED OR USED WITH THE PRODUCT, INCLUDING THE COSTS OF REPAIRING, REPLACING, INTEGRATING, INSTALLING OR RECOVERING SUCH HARDWARE, SOFTWARE, OR DATA.

---

Any disputes arising between the manufacturer and the customer shall be governed by the laws of Santa Clara County in the State of California, USA. The State of California, County of Santa Clara shall be the exclusive venue for the resolution of any such disputes. Supermicro's total liability for all claims will not exceed the price paid for the hardware product.

---

FCC Statement: This equipment has been tested and found to comply with the limits for a Class A digital device pursuant to Part 15 of the FCC Rules. These limits are designed to provide reasonable protection against harmful interference when the equipment is operated in a commercial environment. This equipment generates, uses, and can radiate radio frequency energy and, if not installed and used in accordance with the manufacturer's instruction manual, may cause harmful interference with radio communications. Operation of this equipment in a residential area is likely to cause harmful interference, in which case you will be required to correct the interference at your own expense.

---

California Best Management Practices Regulations for Perchlorate Materials: This Perchlorate warning applies only to products containing CR (Manganese Dioxide) Lithium coin cells. "Perchlorate Material-special handling may apply. See [www.dtsc.ca.gov/hazardouswaste/perchlorate](http://www.dtsc.ca.gov/hazardouswaste/perchlorate)".

**WARNING:** Handling of lead solder materials used in this product may expose you to lead, a chemical known to the State of California to cause birth defects and other reproductive harm.

---

Manual Revision 1.0

Release Date: Oct. 14, 2015

Unless you request and receive written permission from Super Micro Computer, Inc., you may not copy any part of this document.

Information in this document is subject to change without notice. Other products and companies referred to herein are trademarks or registered trademarks of their respective companies or mark holders.

Copyright © 2015 by Super Micro Computer, Inc.  
All rights reserved.

**Printed in the United States of America**

## Preface

This manual is written for system integrators, IT professionals, and knowledgeable end-users. It provides information for the installation and use of the X10QBL-4CT/X10QBL-4 motherboard.

### About This Motherboard

The Super X10QBL-4(CT) motherboard supports four Intel E7-4800 V3 (Socket R1) series processors that offer the new Intel Microarchitecture 22nm Processing technology, delivering the best balanced solution for the diverse needs of next-generation data centers. With the PCH C602J built in, the X10QBL-4(CT) motherboard supports MCTP Protocol, and Intel® Node Manager 3.0. This motherboard is optimized for high-performance, cost-effective, cloud-computing systems. Please refer to our website (<http://www.supermicro.com>) for CPU and memory support updates.

### Manual Organization

**Chapter 1** describes the features, specifications and performance of the motherboard. It also provides detailed information about the Intel PCH C602J chipset.

**Chapter 2** provides hardware installation instructions. Read this chapter when installing the processor, memory modules and other hardware components into the system. If you encounter any problems, see **Chapter 3**, which describes troubleshooting procedures for video, memory, and system setup stored in the CMOS.

**Chapter 4** includes an introduction to the BIOS, and provides detailed information on running the CMOS Setup utility.

**Appendix A** provides BIOS Error Beep codes.

**Appendix B** lists software installation instructions.

**Appendix C** contains UEFI BIOS Recovery instructions.

## Conventions Used in the Manual

Pay special attention to the following symbols for proper system installation:

**Warning:** Important information given to ensure proper system installation or to prevent damage to the components or injury to yourself;



**Note:** Additional information given to differentiate between models or instructions provided for proper system setup.

## Contacting Supermicro

### Headquarters

Address: Super Micro Computer, Inc.  
980 Rock Ave.  
San Jose, CA 95131 U.S.A.

Tel: +1 (408) 503-8000

Fax: +1 (408) 503-8008

Email: [marketing@supermicro.com](mailto:marketing@supermicro.com) (General Information)  
[support@supermicro.com](mailto:support@supermicro.com) (Technical Support)

Web Site: [www.supermicro.com](http://www.supermicro.com)

### Europe

Address: Super Micro Computer B.V.  
Het Sterrenbeeld 28, 5215 ML  
's-Hertogenbosch, The Netherlands

Tel: +31 (0) 73-6400390

Fax: +31 (0) 73-6416525

Email: [sales@supermicro.nl](mailto:sales@supermicro.nl) (General Information)  
[support@supermicro.nl](mailto:support@supermicro.nl) (Technical Support)  
[rma@supermicro.nl](mailto:rma@supermicro.nl) (Customer Support)

Web Site: [www.supermicro.nl](http://www.supermicro.nl)

### Asia-Pacific

Address: Super Micro Computer, Inc.  
3F, No. 150, Jian 1st Rd.  
Zhonghe Dist., New Taipei City 235  
Taiwan (R.O.C)

Tel: +886-(2) 8226-3990

Fax: +886-(2) 8226-3992

Email: [support@supermicro.com.tw](mailto:support@supermicro.com.tw)

Web Site: [www.supermicro.com.tw](http://www.supermicro.com.tw)

# Table of Contents

## Preface

### Chapter 1 Overview

1-1	Overview .....	1-1
1-2	Processor and Chipset Overview.....	1-11
1-3	Special Features .....	1-12
1-4	System Health Monitoring.....	1-12
1-5	ACPI Features.....	1-13
1-6	Power Supply .....	1-13
1-7	Advanced Power Management.....	1-14
	Intel® Intelligent Power Node Manager (NM) (Available when the Supermicro Power Manager [SPM] is Installed) .....	1-14
	Management Engine (ME) .....	1-14

### Chapter 2 Installation

2-1	Standardized Warning Statements .....	2-1
2-2	Static-Sensitive Devices.....	2-4
2-3	Motherboard Installation.....	2-5
2-4	Processor and Heatsink Installation.....	2-7
2-5	Installing and Removing the Memory Modules.....	2-13
	Installing & Removing DIMMs.....	2-13
	Removing Memory Modules .....	2-13
2-6	Control Panel Connectors and I/O Ports .....	2-16
	Back Panel Connectors and I/O Ports.....	2-16
	Back Panel I/O Port Locations and Definitions .....	2-16
	COM Port/Serial Connection Header .....	2-17
	Universal Serial Bus (USB).....	2-17
	Video Connection .....	2-18
	Ethernet Ports .....	2-18
	Unit Identifier Switches/UID LED Indicators.....	2-19
	Front Control Panel.....	2-20
	Front Control Panel Pin Definitions.....	2-21
	NMI Button .....	2-21
	Power LED .....	2-21
	HDD/UID LED .....	2-22
	NIC1/NIC2 LED Indicators .....	2-22
	Overheat (OH)/Fan Fail/PWR Fail/UID LED .....	2-23
	Power Fail LED .....	2-23

	Reset Button .....	2-24
	Power Button .....	2-24
2-7	Connecting Cables.....	2-25
	Power Connectors .....	2-25
	Fan Headers.....	2-26
	IPMB.....	2-26
	TPM/Port 80 Header .....	2-27
	SATA DOM Power Connectors .....	2-27
	Chassis Intrusion .....	2-28
	Internal Speaker.....	2-28
	I-SGPIO 1/2 Headers.....	2-29
	Power LED/Speaker.....	2-29
	Standby Power Header.....	2-30
	Power SMB (I <sup>2</sup> C) Connector .....	2-30
2-8	Jumper Settings .....	2-31
	Explanation of Jumpers .....	2-31
	LAN Enable/Disable .....	2-31
	CMOS Clear.....	2-32
	Watch Dog Enable/Disable .....	2-32
	VGA Enable.....	2-33
	BMC Enable .....	2-33
	I <sup>2</sup> C Bus to PCI-Exp. Slots .....	2-34
	TPM Support Enable.....	2-34
	Manufacturer Mode Select.....	2-35
	SAS Enable (for X10QBL-4CT only).....	2-35
	SAS HDD Status Support Enable (for X10QBL-4CT only).....	2-36
2-9	Onboard LED Indicators .....	2-37
	LAN LEDs.....	2-37
	IPMI_LAN LEDs .....	2-37
	Onboard Power LED .....	2-38
	BMC Heartbeat LED .....	2-38
	SAS Heartbeat LED (for X10QBL-4CT only).....	2-39
	SAS Activity LED (for X10QBL-4CT only).....	2-39
2-10	SATA/SAS 3.0 Connections .....	2-40
	SATA 3.0 Ports .....	2-40
	SAS 3.0 Ports (for X10QBL-4CT only) .....	2-40
<b>Chapter 3 Troubleshooting</b>		
3-1	Troubleshooting Procedures .....	3-1

3-2 Technical Support Procedures ..... 3-5  
3-3 Battery Removal and Installation ..... 3-6  
3-4 Frequently Asked Questions ..... 3-7  
3-5 Returning Merchandise for Service..... 3-8

**Chapter 4 BIOS**

4-1 Introduction..... 4-1  
4-2 Main Setup ..... 4-2  
4-3 Advanced Setup Configurations..... 4-4  
4-4 Event Logs ..... 4-33  
4-5 IPMI ..... 4-35  
4-6 Security ..... 4-37  
4-7 Boot ..... 4-38  
4-8 Save & Exit ..... 4-40

**Appendix A BIOS Error Beep Codes**

A-1 BIOS Error Beep Codes ..... A-1

**Appendix B Software Installation Instructions**

B-1 Installing Software Programs ..... B-1  
B-2 Configuring SuperDoctor 5 ..... B-2

**Appendix C UEFI BIOS Recovery Instructions**

C-1 An Overview to the UEFI BIOS ..... C-1  
C-2 How to Recover the UEFI BIOS Image (-the Main BIOS Block)..... C-1  
C-3 To Recover the Main BIOS Block Using a USB-Attached Device..... C-1

# Chapter 1

## Overview

### 1-1 Overview

#### Checklist

Congratulations on purchasing your computer motherboard from an acknowledged leader in the industry. Supermicro boards are designed with the utmost attention to detail to provide you with the highest standards in quality and performance.

 **Note 1:** The X10QBL-4(CT) motherboard was designed to be used with a Supermicro-proprietary chassis as an integrated server platform. It is not to be used as a stand-alone product and will not be shipped independently in a retail box. No motherboard shipping package will be provided in your shipment.

 **Note 2:** For your system to work properly, please follow the links below to download all necessary drivers/utilities and the user's manual for your system.

- Supermicro product manuals: <http://www.supermicro.com/support/manuals/>
- Product Drivers and utilities: <ftp://ftp.supermicro.com/>

 **Note 3:** For safety considerations, please refer to the complete list of safety warnings posted on the Supermicro website at [http://www.supermicro.com/about/policies/safety\\_information.cfm](http://www.supermicro.com/about/policies/safety_information.cfm).

If you have any questions, please contact our support team at [support@supermicro.com](mailto:support@supermicro.com).

## SUPER<sup>®</sup> X10QBL-4(CT) Motherboard Image

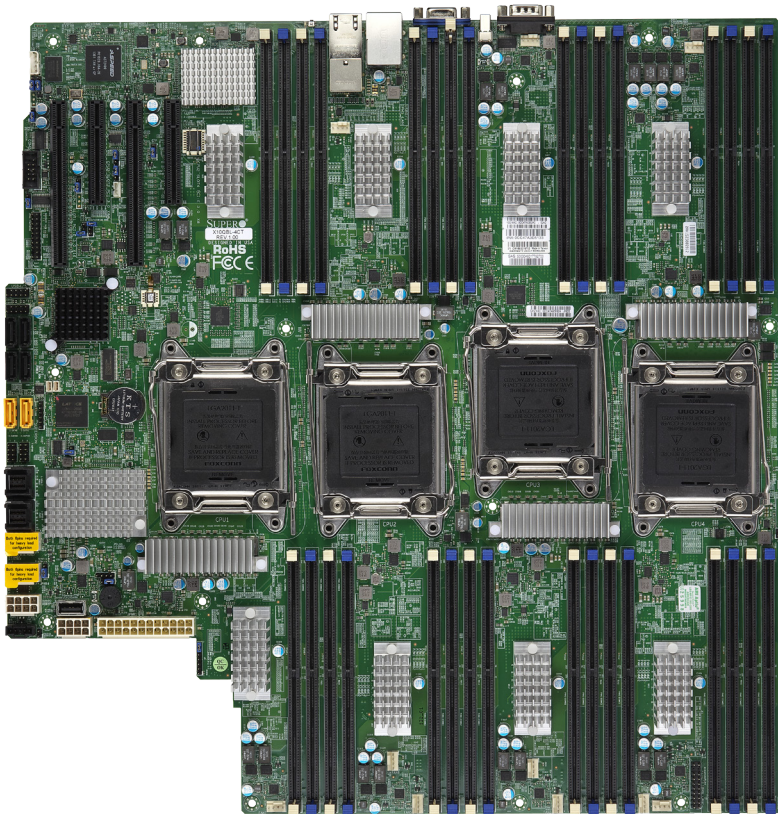

**Note:** All graphics shown in this manual were based upon the latest PCB revision available at the time of publishing of the manual. The motherboard you've received may or may not look exactly the same as the graphics shown in this manual.

## X10QBL-4(CT) Motherboard Layout

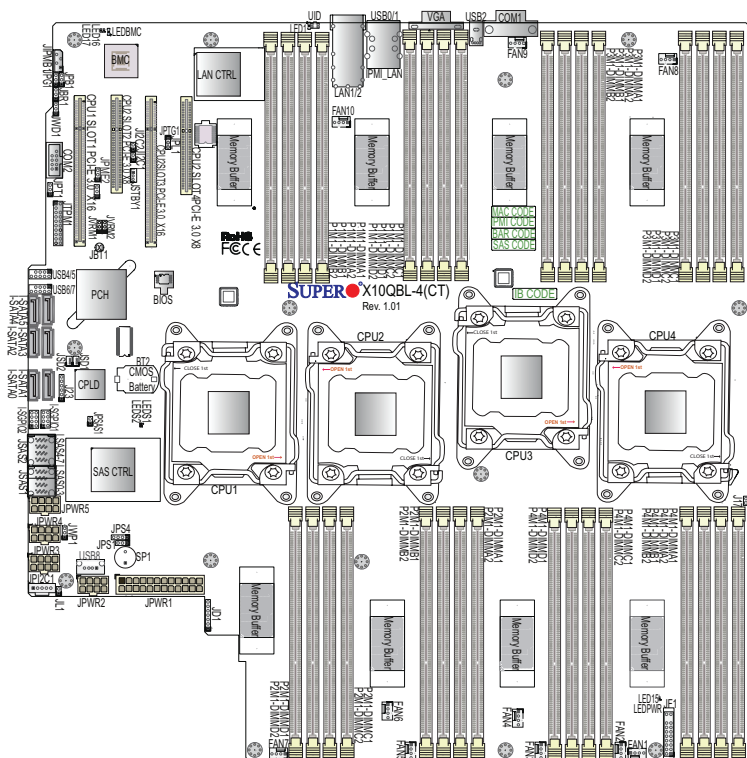

## Differences between the X10QBL-4CT and the X10QBL-4

Item/Description	X10QBL-4CT	X10QBL-4
SAS Support	Yes	No
LSI SAS Controller 3008	Yes	No
SAS0-3 (JSAS1)	Supported	No
SAS4-7 (JSAS2)	Supported	No
LAN Connection Speed	10G (TGLAN) supported	1G (GLAN) supported
LAN Controller	Intel NIC X540	Intel NIC i350
Platform	High-end platform	Entry-level, cost-effective

 **Note:** For the latest CPU/memory updates, please refer to our website at <http://www.supermicro.com/products/motherboard/> for details.

X10QBL-4(CT) Quick Reference

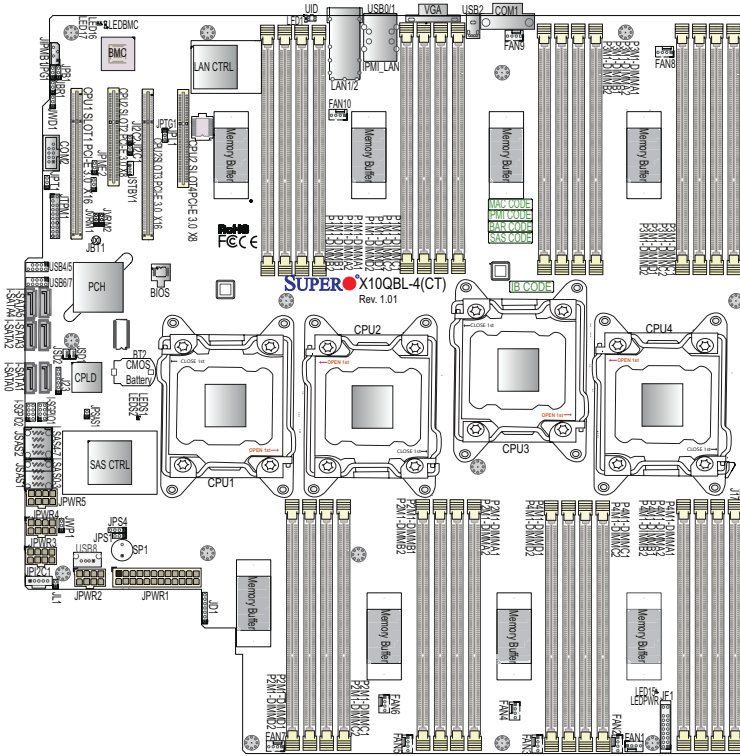

 **Notes:**

- See Chapter 2 for detailed information on jumpers, I/O ports and JF1 front panel connections.
- "■" indicates the location of "Pin 1".
- Jumpers/LED Indicators not indicated are for internal testing only.
- Use only the correct type of onboard CMOS battery as specified by the manufacturer. Do not install the onboard battery upside down to avoid possible explosion.

**X10QBL-4(CT) Jumpers**

<b>Jumper</b>	<b>Description</b>	<b>Default Setting</b>
JBT1	Clear CMOS	See Chapter 2
JI <sup>2</sup> C1/JI <sup>2</sup> C2	SMB to PCI-E slots	Pins 2-3 (Disabled)
JPB1	BMC Enable	Pins 1-2 (Enabled)
JPG1	VGA Enable	Pins 1-2 (Enabled)
JPL1	GLAN1/GLAN2 Enable (X10QBL-4)	Pins 1-2 (Enabled)
JPTG1	10G-LAN1/ 10G-LAN2 Enable (X10QBL-4CT)	Pins 1-2 (Enabled)
JPME2	Manufacture Mode (ME) Select	Pins 1-2 (Normal)
JPS1	SAS Enable (For X10QBL-4CT)	Pins 1-2 (Enabled)
JPSAS1	SAS HDD Status Support Enable (For X10QBL-4CT)	Off (Disabled)
JPT1	Trusted-Platform Module (TPM) Enable	Pins 1-2 (Enabled)
JWD1	Watch-Dog Timer Enable	Pins 1-2 (Reset)

**X10QBL-4(CT) Connectors**



<b>Connectors</b>	<b>Description</b>
BT2 (Battery)	Onboard CMOS Battery (See Chpt. 3 for used battery disposal.)
COM1/COM2	Back panel COM port 1/Serial port 2 header
FAN1-FAN10	CPU/System fan headers
I-SATA0/1	Intel SATA 3.0 ports 0/1 used as SuperDOM (Self-powered SATA Disk-on-module devices with power-pins built-in) (supported by Intel PCH)
I-SATA2-5	Intel SATA 3.0/2.0 ports 0-5 (I-SATA 3.0 ports 0/1, I-SATA 2.0 ports 2-5) (supported by Intel PCH)
JD1	Speaker/Power LED header
JF1	Front Panel Control header
JIPMB1	4-pin external BMC I <sup>2</sup> C header (for IPMI-card support)
JL1	Chassis intrusion header
JPI <sup>2</sup> C1	Power System Management Bus (SMB) header
JPWR1	24-pin power connection header
JPWR2/3/4/5	8-pin power connectors
JVRM1/JVRM2	CPU VRM headers
LAN1/2 (for X10QBL-4)	Gigabit Ethernet LAN ports 1/2 (supported by Intel i350 LAN controller)
LAN1/2 (for X10QBL-4CT)	10G-LAN (TLAN) ports 1/2 (supported by Intel X540 LAN controller)

IPMI_LAN	Gigabit IPMI-dedicated LAN on the I/O back panel (supported by the BMC for IPMI use)
L-SAS0-3, L-SAS4-7 (for X10QBL-4CT)	SAS ports 0-3, 4-7 (supported by LSI 3008 SAS controller)
JSD1/JSD2	SATA DOM (Device-On-Module) power connectors 1/2
JSTBY1	Standby power connection header
JTPM1	TPM (Trusted Platform Module)/Port 80 header
(CPU1) Slot1	PCI-Exp. 3.0x16 slot (supported by CPU1)
(CPU2) Slot2/4	PCI-Exp. 3.0x8 slots (supported by CPU2)
(CPU2) Slot3	PCI-Exp. 3.0x16 slot (supported by CPU2)
SP1	Internal speaker/buzzer
I-SGPIO1/2	Serial_Link General-purpose I/O connectors 1/2 for I-SATA 0-5 support
(BP)USB0/1	Rear USB 2.0 ports 0/1 on the I/O back panel
(BP)USB2	Rear USB 2.0 port 2 on the I/O back panel
USB4/5	USB 2.0 connections 4/5 header for front access
USB6/7	USB 2.0 connections 6/7 header for front access
USB8	Type A USB 2.0 header 8
UID	Unit-Identification (UID) button
VGA	Back panel VGA port

**X10QBL-4(CT) LED Indicators**

LED	Description	State	Status
LED1	Rear UID LED	Blue: On	Unit Identified
LED15 (LEDPWR)	Onboard Power LED	On	Power On
LEDBMC	BMC Heartbeat LED	Green: Blinking	BMC Normal
LEDS1 (X10QBL-4CT)	SAS Heartbeat LED	Green: On	SAS Normal
		Red: On	SAS Failed
LEDS2 (for X10QBL-4CT)	SAS Activity LED	Green: Blinking	SAS Active

## Motherboard Features

<b>CPU</b>	<ul style="list-style-type: none"> <li>Quad Intel® E7-4800 V3 (Socket R1) series processors; each processor supports dual full-width Intel QuickPath Interconnect (QPI) links (of up to 8.0 GT/s one direction per QPI)</li> </ul> <p> <b>Note:</b> For the latest CPU support updates, please refer to our website at <a href="http://www.supermicro.com/products/motherboard">http://www.supermicro.com/products/motherboard</a>.</p>	
<b>Memory</b>	<ul style="list-style-type: none"> <li>Integrated memory controller supports: Up to 1TB of Registered (RDIMM) or up to 4TB of Load Reduced (LRDIMM) DDR4 (288-pin) ECC 1866/1600/1333 MHz memory modules in 32 slots (2 DIMMs per channel).</li> </ul> <p> <b>Note:</b> Memory speed support is pending on the CPUs installed in the system. For the latest memory updates, please refer to our website at <a href="http://www.supermicro.com/products/motherboard">http://www.supermicro.com/products/motherboard</a>.</p>	
	<b>DIMM sizes</b>	
	<ul style="list-style-type: none"> <li>DIMM</li> </ul>	Up to 128 GB @ 1.2V
<b>Chipset</b>	<ul style="list-style-type: none"> <li>Intel® PCH C602J</li> </ul>	
<b>Expansion Slots</b>	<ul style="list-style-type: none"> <li>Two (2) PCI-E 3.0 x16 slots (CPU1 Slot1, CPU2 Slot3)</li> </ul>	
	<ul style="list-style-type: none"> <li>Two (2) PCI-E 3.0 x8 slots (CPU2 Slot2, CPU2 Slot4)</li> </ul>	
<b>Graphics</b>	<ul style="list-style-type: none"> <li>Graphics controller via ASpeed AST2400 BMC (Baseboard Controller)</li> </ul>	
<b>Network</b>	<ul style="list-style-type: none"> <li>Intel i350 Gigabit (10/100/1000 Mb/s) Ethernet controller for LAN Port 1/Port 2 (X10QBL-4 only),</li> <li>Intel X540 10-Gigabit Ethernet controller for 10G-LAN (TLAN) Port1/Port 2 (X10QBL-4CT only)</li> </ul>	
	<ul style="list-style-type: none"> <li>ASpeed 2400 Baseboard Controller (BMC) supports IPMI_LAN 2.0</li> </ul>	
<b>I/O Devices</b>	<b>SATA Connections</b>	
	<ul style="list-style-type: none"> <li>SATA Ports</li> </ul>	<ul style="list-style-type: none"> <li>Two (2) SATA 3.0 ports w/ SuperDOM support (I-SATA 1/2) (from Intel PCH)</li> <li>Four (4) SATA 2.0 connections (I-SATA 2-5) (from Intel PCH)</li> </ul>

	<ul style="list-style-type: none"> <li>RAID</li> </ul>	RAID 0, 1, 5, 10
	<b>SAS Connections (For X10QBL-4CT only)</b>	
	<ul style="list-style-type: none"> <li>SAS 3.0</li> </ul>	<ul style="list-style-type: none"> <li>SAS 0-3 (JSAS1),</li> <li>SAS 4-7 (JSAS2)</li> </ul> <p>supported by the LSI 3008 SAS controller</p>
	<ul style="list-style-type: none"> <li>RAID</li> </ul>	RAID 0, 1, 10
	<b>IPMI 2.0</b>	
	<ul style="list-style-type: none"> <li>IPMI 2.0 supported by ASpeed AST 2400</li> </ul>	
	<b>Serial Port &amp; COM Port Header</b>	
	<ul style="list-style-type: none"> <li>One (1) Fast UART 16550 serial port header for front access (COM2),</li> <li>One (1) COM port (COM1) on the IO back panel</li> </ul>	
<b>Peripheral Devices</b>	<b>USB Devices</b>	
	<ul style="list-style-type: none"> <li>Two (2) USB 2.0 ports on the I/O back panel (USB 0/1)</li> <li>One (1) USB 2.0 on the I/O back panel (USB 2)</li> </ul>	
	<ul style="list-style-type: none"> <li>Two (2) USB 2.0 headers provide four USB 2.0 connections for front access support (USB 4/5, USB 6/7)</li> <li>One (1) USB 2.0 Type A for front access support (USB 8)</li> </ul>	
<b>BIOS</b>	<ul style="list-style-type: none"> <li>16 MB SPI AMI BIOS® SM Flash UEFI BIOS</li> </ul>	
	<ul style="list-style-type: none"> <li>APM 1.2, ACPI 3.0/4.0, USB keyboard, Plug &amp; Play (PnP), BIOS rescue hotkey, riser card auto-detection, RTC (Real-Time Clock) wake-up, PCI Firmware 3.0, SPI dual/quad speed support, and SMBIOS 2.7 &amp; later</li> </ul>	
<b>Power Management</b>	<ul style="list-style-type: none"> <li>ACPI/ACPM power management</li> </ul>	
	<ul style="list-style-type: none"> <li>S4, S5 support</li> </ul>	
	<ul style="list-style-type: none"> <li>Wake-on-Ring (WOR) &amp; Wake-on-LAN (WOL) support</li> </ul>	
	<ul style="list-style-type: none"> <li>Power-on mode for AC power recovery</li> </ul>	
	<ul style="list-style-type: none"> <li>Main switch override mechanism</li> </ul>	

	<ul style="list-style-type: none"> <li>• Power-on mode for AC power recovery</li> <li>• Intel® Intelligent Power Node Manager 3.0 (Available when the Supermicro Power Manager [SPM] is installed and special power supply is used.)</li> <li>• Management Engine (ME)</li> </ul>
<b>System Health Monitoring</b>	<b>System Health/CPU Monitoring</b>
	<ul style="list-style-type: none"> <li>• Onboard voltage monitoring for +1.2V, +3.3V, 3.3V standby, +5V, +5V standby, +/-12V, CPU core, memory, chipset, and battery voltages</li> </ul>
	<ul style="list-style-type: none"> <li>• CPU/System overheat LED and control</li> </ul>
	<ul style="list-style-type: none"> <li>• 6+1 switch-phase voltage regulator</li> </ul>
	<ul style="list-style-type: none"> <li>• CPU Thermal Trip support</li> </ul>
	<ul style="list-style-type: none"> <li>• Status Monitor for speed control</li> </ul>
	<ul style="list-style-type: none"> <li>• Status Monitor for On/Off control</li> </ul>
	<b>Fan Control</b>
	<ul style="list-style-type: none"> <li>• Fan status monitoring via IPMI connections</li> </ul>
	<ul style="list-style-type: none"> <li>• Single Cooling Zone</li> </ul>
	<ul style="list-style-type: none"> <li>• Low noise fan speed control</li> </ul>
	<ul style="list-style-type: none"> <li>• Pulse Width Modulation (PWM) fan control</li> </ul>
<b>System Management</b>	<ul style="list-style-type: none"> <li>• PECEI (Platform Environment Configuration Interface) 2.0/TSI support</li> </ul>
	<ul style="list-style-type: none"> <li>• Chassis intrusion auto detection</li> </ul>
	<ul style="list-style-type: none"> <li>• UID (Unit Identification)/Remote UID</li> </ul>
	<ul style="list-style-type: none"> <li>• System resource alert via SuperDoctor® 5</li> </ul>
	<ul style="list-style-type: none"> <li>• SuperDoctor 5, Watch Dog, NMI</li> </ul>
	<ul style="list-style-type: none"> <li>• Chassis Intrusion header and detection</li> </ul>
<b>Dimensions</b>	<ul style="list-style-type: none"> <li>• 16.40" (L) x 16.79" (W) (426.47 mm x 424.18 mm)</li> </ul>

 **Note:** For IPMI Configuration instructions, please refer to the Embedded IPMI Configuration User's Guide available @ <http://www.supermicro.com/support/manuals/>.

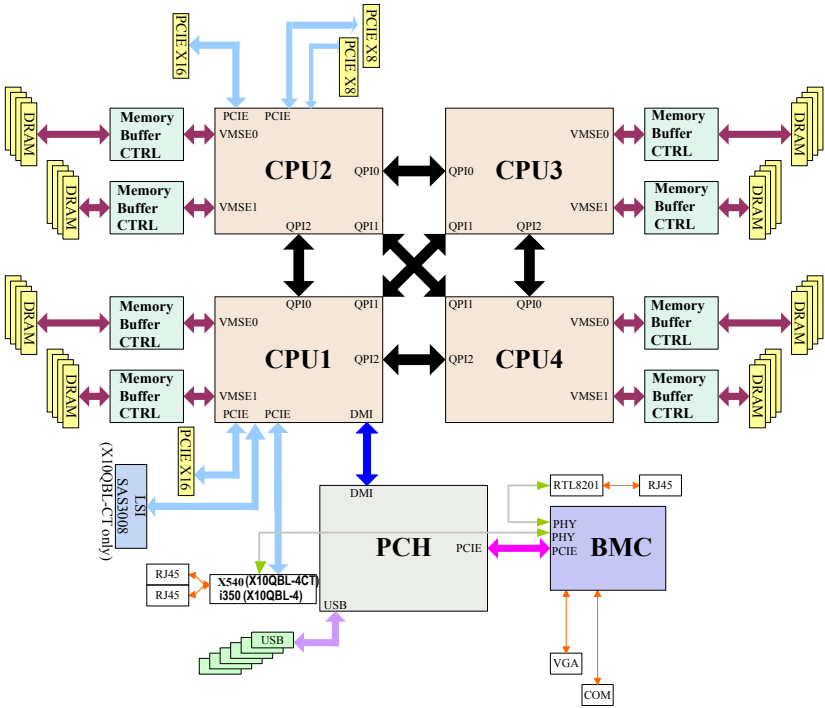

### System Block Diagram



**Note:** This is a general block diagram and may not represent the features on your motherboard. See the "Motherboard Features" pages for the actual specifications of each motherboard.

## 1-2 Processor and Chipset Overview

Built upon the functionality and capability of the Intel E7-4800 V3 processors (Socket R1) and the Intel C602J PCH, the X10QBL-4(CT) motherboard provides the best solution for cost-effective, high-performance, cloud-computing platforms.

With support of the new Intel Microarchitecture 22nm Processing technology, the X10QBL-4(CT) dramatically increases performance for a multitude of server applications.

The PCH C602J chip provides enterprise System Management Bus (SMBus) and MCTP support with the following features included:

- DDR4 288-pin memory support on Socket R1
- Support for MCTP protocol and ME
- Support of SMBus speeds of up to 1 MHz for BMC connectivity
- GSX capable of GPIO expansion
- Improved I/O capabilities to high-storage-capacity configurations
- SPI Enhancements
- Intel® Node Manager 3.0 for advanced power monitoring
- BMC supports remote management, virtualization, and the security package for enterprise platforms

## 1-3 Special Features

### Recovery from AC Power Loss

The Basic I/O System (BIOS) provides a setting that determines how the system will respond when AC power is lost and then restored to the system. You can choose for the system to remain powered off (in which case you must press the power switch to turn it back on), or for it to automatically return to the power-on state. See the Advanced BIOS Setup section for this setting. The default setting is **Last State**.

## 1-4 System Health Monitoring

This section describes the features of system health monitoring of the motherboard. This motherboard has an onboard BaseBoard Management Controller (BMC) chip that monitors system health. An onboard voltage monitor will scan the following onboard voltages continuously: +1.2 V, +3.3V, 3.3V standby, +5V, +5V standby, +/-12V, CPU core, memory, chipset, and battery voltages. Once the voltage becomes unstable, a warning is given, or an error message is sent to the screen. The user can adjust the voltage thresholds to define the sensitivity of the voltage monitor.

### Fan Status Monitor with Firmware Control

The system health monitoring support provided by the BMC controller can check the RPM status of a cooling fan. The onboard CPU and chassis fan speeds are controlled by IPMI thermal management.

### Environmental Temperature Control

A thermal control sensor in the BMC monitors the CPU temperatures in real time and will turn on the thermal control fan whenever the CPU temperature exceeds a user-defined threshold. Once it detects that the CPU temperature is too high, it will automatically turn on the thermal fan control to prevent the CPU from overheating. The onboard BMC can monitor the overall system temperature and alert the user when the chassis temperature is too high.

 **Note:** To avoid possible system overheating, please be sure to provide adequate airflow to your system.

### System Resource Alert

This feature is available when used with SuperDoctor 5. SuperDoctor 5 is used to notify the user of certain system events. For example, you can configure SuperDoctor 5 to provide you with warnings when the system temperature, CPU

temperatures, voltages, and fan speeds go beyond a predefined range.

## 1-5 ACPI Features

ACPI stands for Advanced Configuration and Power Interface. The ACPI specification defines a flexible and abstract hardware interface that provides a standard way to integrate power management features throughout a system, including its hardware, operating system and application software. This enables the system to automatically turn on and off peripherals such as, network cards, hard disk drives and printers.

In addition to operating system-directed power management, ACPI also provides a generic system event mechanism for Plug and Play, and an operating system-independent interface for configuration control. ACPI leverages the Plug and Play BIOS data structures, while providing a processor architecture-independent implementation that is compatible with the Windows 2008/R2 and Windows 2012/R2 operating systems.

## 1-6 Power Supply

As with all computer products, a stable power source is necessary for proper and reliable operation. It is even more important for processors that have high CPU clock rates.

The X10QBL-4(CT) motherboard accommodates a 24-pin ATX main power (JPWR1) and four 8-pin 12V power connectors (JPWR2-5). To provide adequate power to your system, be sure to connect all these power connectors to your power supply. Also, be sure to use the power supply recommended for this motherboard by Supermicro.

It is recommended that you also install a power surge protector to help avoid problems caused by power surges.

## 1-7 Advanced Power Management

The following new advanced power management features are supported by this motherboard:

### **Intel<sup>®</sup> Intelligent Power Node Manager (NM) (Available when the Supermicro Power Manager [SPM] is Installed)**

The Intel<sup>®</sup> Intelligent Power Node Manager 3.0 (IPNM) provides your system with real-time thermal control and power management for maximum energy efficiency. Although IPNM Specification Version 1.5/2.0 is supported by the BMC (Baseboard Management Controller), your system must also have IPNM-compatible Management Engine (ME) firmware installed to use this feature.



**Note:** Support for IPNM Specification Version 1.5 or Vision 2.0 depends on the power supply used in the system.

### **Management Engine (ME)**

Management Engine, an ARC controller embedded in the PCH, provides Server Platform Services (SPS) support to your system. The services provided by SPS are different from those provided by the ME on the client platforms.

---

---

## Chapter 2

### Installation

#### 2-1 Standardized Warning Statements

The following statements are industry-standard warnings, provided to warn the user of situations which may cause bodily injury. Should you have questions or experience difficulty, contact Supermicro Technical Support for assistance. Only certified technicians should attempt to install or configure components.

Read this section in its entirety before installing or configuring components in the Supermicro chassis.

#### Battery Handling



##### Warning!

There is a danger of explosion if the battery is replaced incorrectly. Replace the battery only with the same or equivalent type recommended by the manufacturer. Dispose of used batteries according to the manufacturer's instructions

##### 電池の取り扱い

電池交換が正しく行われなかった場合、破裂の危険性があります。交換する電池はメーカーが推奨する型、または同等のものを使用下さい。使用済電池は製造元の指示に従って処分して下さい。

##### 警告

電池更換不當會有爆炸危險。請只使用同類電池或製造商推薦的功能相當的電池更換原有電池。請按製造商的說明處理廢舊電池。

##### 警告

電池更換不當會有爆炸危險。請使用製造商建議之相同或功能相當的電池更換原有電池。請按照製造商的說明指示處理廢棄舊電池。

##### Warnung

Bei Einsetzen einer falschen Batterie besteht Explosionsgefahr. Ersetzen Sie die Batterie nur durch den gleichen oder vom Hersteller empfohlenen Batterietyp. Entsorgen Sie die benutzten Batterien nach den Anweisungen des Herstellers.

Attention

Danger d'explosion si la pile n'est pas remplacée correctement. Ne la remplacer que par une pile de type semblable ou équivalent, recommandée par le fabricant. Jeter les piles usagées conformément aux instructions du fabricant.

¡Advertencia!

Existe peligro de explosión si la batería se reemplaza de manera incorrecta. Reemplazar la batería exclusivamente con el mismo tipo o el equivalente recomendado por el fabricante. Desechar las baterías gastadas según las instrucciones del fabricante.

**אזהרה!**

קיימת סכנת פיצוץ של הסוללה במידה והוחלפה בדרך לא תקינה. יש להחליף את הסוללה בסוג התואם מחברת יצרן מומלצת.

סילוק הסוללות המשומשות יש לבצע לפי הוראות היצרן.

هناك خطر من انفجار في حالة استبدال البطارية بطريقة غير صحيحة فعليك استبدال البطارية فقط بنفس النوع أو ما يعادلها كما أوصت به الشركة المصنعة تخلص من البطاريات المستعملة وفقا لتعليمات الشركة الصانعة

경고!

배터리가 올바르게 교체되지 않으면 폭발의 위험이 있습니다. 기존 배터리와 동일하거나 제조사에서 권장하는 동등한 종류의 배터리로만 교체해야 합니다. 제조사의 안내에 따라 사용된 배터리를 처리하여 주십시오.

Waarschuwing

Er is ontploffingsgevaar indien de batterij verkeerd vervangen wordt. Vervang de batterij slechts met hetzelfde of een equivalent type die door de fabrikant aanbevolen wordt. Gebruikte batterijen dienen overeenkomstig fabrieksvorschriften afgevoerd te worden.

## Product Disposal



### Warning!

Ultimate disposal of this product should be handled according to all national laws and regulations.

### 製品の廃棄

この製品を廃棄処分する場合、国の関係する全ての法律・条例に従い処理する必要があります。

### 警告

本产品的废弃处理应根据所有国家的法律和规章进行。

### 警告

本產品的廢棄處理應根據所有國家的法律和規章進行。

### Warnung

Die Entsorgung dieses Produkts sollte gemäß allen Bestimmungen und Gesetzen des Landes erfolgen.

### ¡Advertencia!

Al deshacerse por completo de este producto debe seguir todas las leyes y reglamentos nacionales.

### Attention

La mise au rebut ou le recyclage de ce produit sont généralement soumis à des lois et/ou directives de respect de l'environnement. Renseignez-vous auprès de l'organisme compétent.

## סילוק המוצר

### אזהרה!

סילוק סופי של מוצר זה חייב להיות בהתאם להנחיות וחוקי המדינה.

عند التخلص النهائي من هذا المنتج ينبغي التعامل معه وفقا لجميع القوانين واللوائح الوطنية

경고!

이 제품은 해당 국가의 관련 법규 및 규정에 따라 폐기되어야 합니다.

Waarschuwing

De uiteindelijke verwijdering van dit product dient te geschieden in overeenstemming met alle nationale wetten en reglementen.

## 2-2 Static-Sensitive Devices

Electrostatic Discharge (ESD) can damage electronic components. To avoid damaging your motherboard, it is important to handle it very carefully. The following measures are generally sufficient to protect your equipment from ESD.

### Precautions

- Use a grounded wrist strap designed to prevent static discharge.
- Touch a grounded metal object before removing the motherboard from the antistatic bag.
- Handle the motherboard by its edges only; do not touch its components, peripheral chips, memory modules or gold contacts.
- When handling chips or modules, avoid touching their pins.
- Put the motherboard and peripherals back into their antistatic bags when not in use.
- For grounding purposes, make sure that your system chassis provides excellent conductivity between the power supply, the case, the mounting fasteners and the motherboard.

### Unpacking

The motherboard is shipped in antistatic packaging to avoid static damage. When unpacking the motherboard, make sure that the person handling it is static protected.

## 2-3 Motherboard Installation

All motherboards have standard mounting holes to fit different types of chassis. Make sure that the locations of all the mounting holes for both motherboard and chassis match. Although a chassis may have both plastic and metal mounting fasteners, metal ones are highly recommended because they ground the motherboard to the chassis. Make sure that the metal standoffs click in or are screwed in tightly. Then use a screwdriver to secure the motherboard onto the motherboard tray.

### Tools Needed

- Phillips Screwdriver
- Pan head screws (14 pieces)
- Standoffs (14 pieces, if needed)

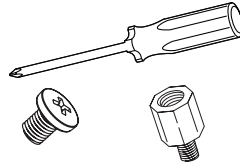

### Location of Mounting Holes

There are fourteen (14) mounting holes on this motherboard indicated by the circles.

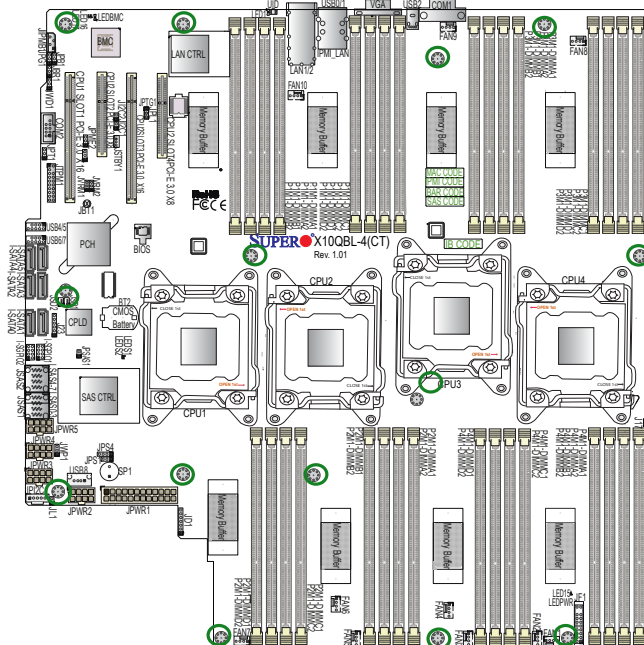

**Caution:** 1) To avoid damaging the motherboard and its components, please do not use a force greater than 8 lb/inch on each mounting screw during motherboard installation. 2) Some components are very close to the mounting holes. Please take precautionary measures to prevent damaging those components when installing the motherboard to the chassis.

## Installing the Motherboard

 **Note:** Always connect the power cord last, and always remove it before adding, removing or changing any hardware components.

1. Install the I/O shield into the chassis.

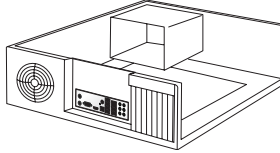

2. Locate the mounting holes on the motherboard.
3. Locate the matching mounting holes on the chassis. Align the mounting holes on the motherboard against the mounting holes on the chassis.
4. Install standoffs in the chassis as needed.

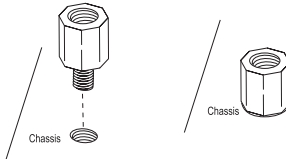

5. Install the motherboard into the chassis carefully to avoid damaging motherboard components.
6. Using the Phillips screwdriver, insert a Pan head #6 screw into a mounting hole on the motherboard and its matching mounting hole on the chassis.

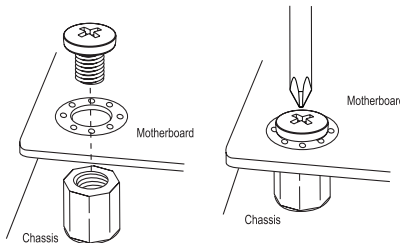

7. Repeat Step 5 to insert #6 screws into all mounting holes.
8. Make sure that the motherboard is securely placed in the chassis.

 **Note:** All graphics, drawings and pictures shown in this manual are for illustration only. The components that came with your machine may or may not look exactly the same as those shown in this manual.

## 2-4 Processor and Heatsink Installation

**Warning:** When handling the processor package, avoid placing direct pressure on the label area. Also, improper CPU installation or socket/pin misalignment can cause serious damage to the CPU or the motherboard and may result in RMA repairs. Be sure to read and follow all instructions thoroughly before installing your CPU and heatsink.

 **Notes:**

Always connect the power cord last, and always remove it before adding, removing or changing any hardware components. Make sure that you install the processor into the CPU socket before you install the CPU heatsink.

If you buy a CPU separately, make sure that you use an Intel-certified multi-directional heatsink only.

Make sure to install the motherboard into the chassis before you install the CPU heatsink.

When receiving a motherboard without a processor pre-installed, make sure that the plastic CPU socket cap is in place, and none of the socket pins are bent; otherwise, contact your retailer immediately.

Refer to the Supermicro website for updates on CPU support.

### Installing the E7-4800 V3 Series Processor

1. There are two load levers on the processor socket. To open the socket lever, first press and release the load lever labeled 'Open 1st'.

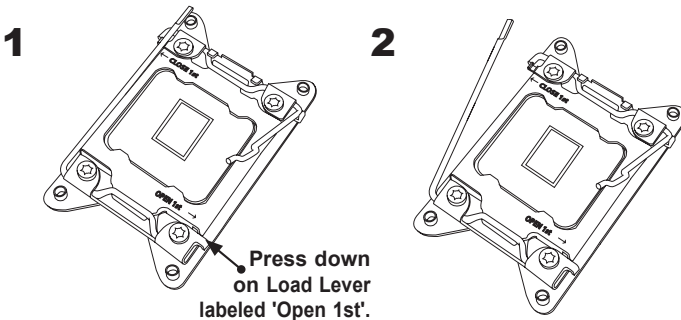

 **Note:** All graphics, drawings and pictures shown in this manual are for illustration only. The components that came with your machine may or may not look exactly the same as those shown in this manual.

2. Press the second load lever labeled 'Close 1st' to release the load plate that covers the CPU socket from its locking position.

**1** Press down on the Load Lever labeled 'Close 1st'

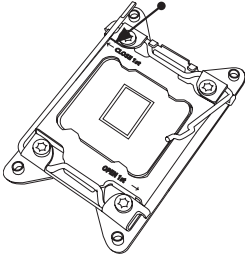

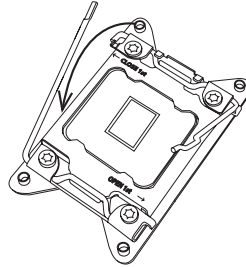

**2** Pull the lever away from the socket

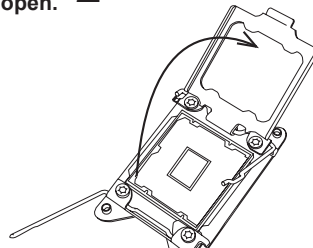
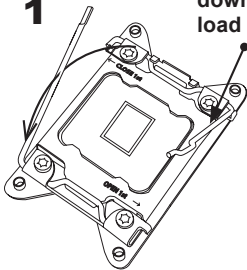

3. With the lever labeled 'Close 1st' fully retracted, gently push down on the lever labeled 'Open 1st' to open the load plate. Lift the load plate to open it completely.

**1** Gently push down to pop the load plate open. **2**



 **Note:** All graphics, drawings and pictures shown in this manual are for illustration only. The components that came with your machine may or may not look exactly the same as those shown in this manual.

- Use your thumb and the index finger to loosen the lever and open the load plate.

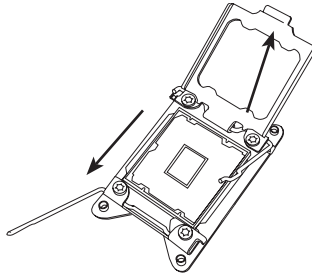

- Using your thumb and index finger, hold the CPU on its edges. Align the CPU keys, which are semi-circle cutouts, against the socket keys.

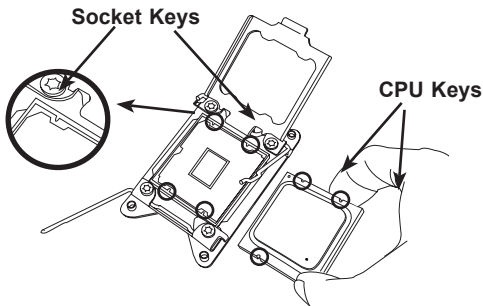

- Once they are aligned, carefully lower the CPU straight down into the socket. (Do not drop the CPU on the socket. Do not move the CPU horizontally or vertically. Do not rub the CPU against the surface or against any pins of the socket to avoid damaging the CPU or the socket.)

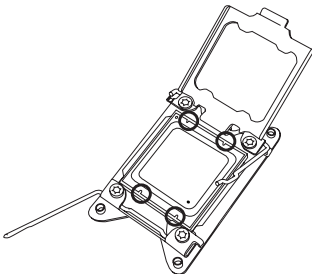

**Warning:** You can only install the CPU inside the socket in one direction. Make sure that it is properly inserted into the CPU socket before closing the load plate. If it doesn't close properly, do not force it as it may damage your CPU. Instead, open the load plate again to make sure that the CPU is aligned properly.

7. With the CPU inside the socket, inspect the four corners of the CPU to make sure that the CPU is properly installed.

**1** Gently close the load plate.

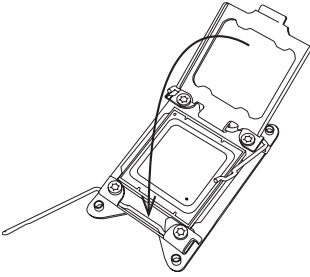

**2** Push down and lock the lever labeled 'Close 1st'.

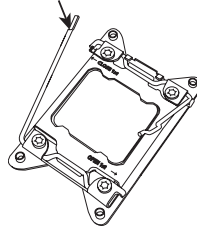

8. Close the load plate with the CPU inside the socket. Lock the lever labeled 'Close 1st' first, then lock the lever labeled 'Open 1st' second. Using your thumb gently push the load levers down to the lever locks.

**3**

Lever Lock

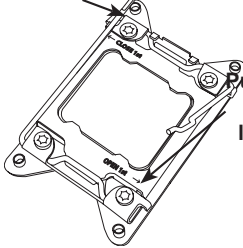

Push down and lock the lever labeled 'Open 1st'.

**4**

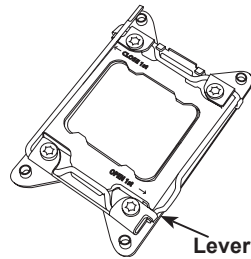

## Installing a Passive CPU Heatsink

1. Do not apply any thermal grease to the heatsink or the CPU die -- the required amount has already been applied.
2. Place the heatsink on top of the CPU so that the four mounting holes are aligned with those on the motherboard and the heatsink bracket underneath.
3. Screw in two diagonal screws (i.e., the #1 and the #2 screws) until just snug (-do not over-tighten the screws to avoid possible damage to the CPU.)
4. Finish the installation by fully tightening all four screws.

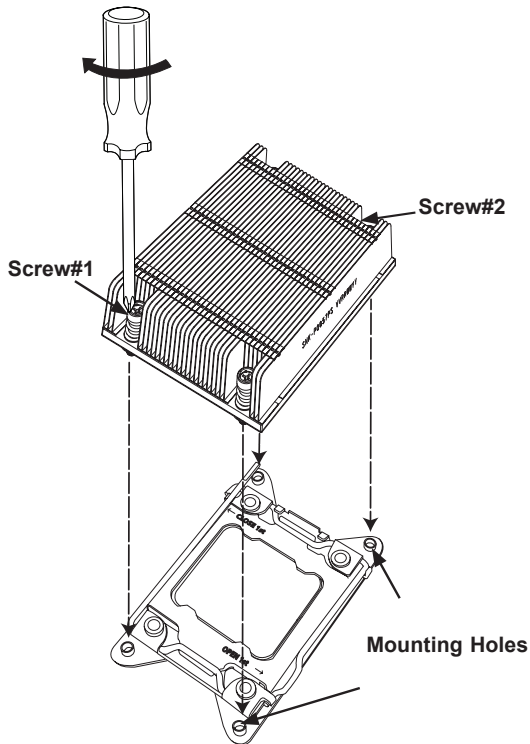

## Removing the Heatsink

**Warning:** We do not recommend that the heatsink be removed. However, if you do need to uninstall the heatsink, please follow the instructions below to uninstall the heatsink to prevent damage done to the CPU, the CPU socket or the heatsink.

1. Unscrew the heatsink screws from the motherboard in the sequence as shown in the illustration below.
2. Gently wriggle the heatsink to loosen it from the CPU socket. (Do not use excessive force when wriggling the heatsink!)
3. Once the heatsink is loosened from the socket, remove it from the CPU socket.
4. To reinstall the heatsink, remove the used thermal grease and clean the surface of the CPU and the heatsink, reapply the proper amount of thermal grease on the surface before reinstalling the heatsink.

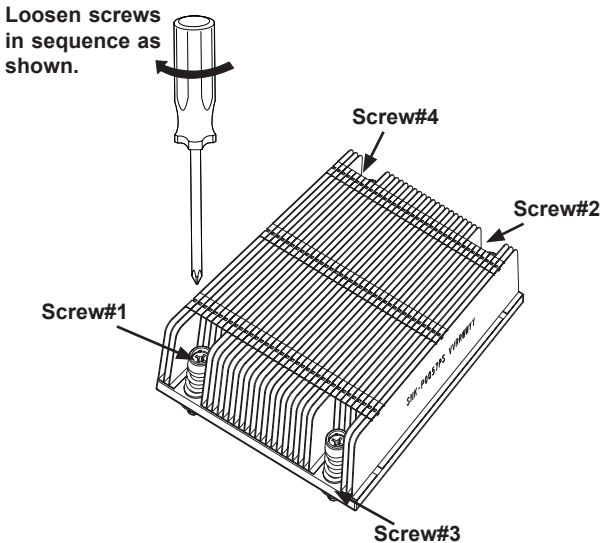

 **Note:** All graphics, drawings and pictures shown in this manual are for illustration only. The components that came with your machine may or may not look exactly the same as those shown in this manual.

## 2-5 Installing and Removing the Memory Modules

**Note:** Check Supermicro's website for recommended memory modules.

### CAUTION

Exercise extreme care when installing or removing DIMM modules to prevent any possible damage.

### Installing & Removing DIMMs

1. Insert the desired number of DIMMs into the memory slots, starting with P1M1-DIMMA1. (For best performance, please use the memory modules of the same type and speed in the same bank.)
2. Push the release tabs outwards on both ends of the DIMM slot to unlock it.

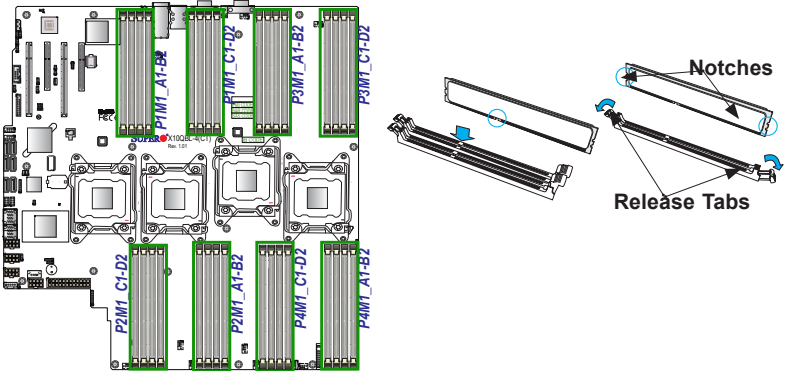

3. Align the key of the DIMM module with the receptive point on the memory slot.
4. Align the notches on both ends of the module against the receptive points on the ends of the slot.
5. Use two thumbs together to press the notches on both ends of the module straight down into the slot until the module snaps into place.
6. Press the release tabs to the locking positions to secure the DIMM module into the slot.

Press both notches straight down into the memory slot at the same time.

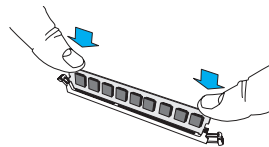

### Removing Memory Modules

Press both notches on the ends of the DIMM module to unlock it. Once the DIMM module is loosened, remove it from the memory slot.

### Memory Support for the X10QBL-4(CT) Motherboard

The X10QBL-4(CT) Motherboard supports 288-pin DDR4 ECC memory of up to 1TB of Registered (RDIMM) or up to 4TB of Load Reduced (LRDIMM) 1866/1600/1333 MHz modules in 32 slots (2 DIMMs per channel). For the latest memory updates, please refer to our website at <http://www.supermicro.com/products/motherboard>.

#### Processor & Memory Module Population Configuration

For memory to work properly, follow the tables below for memory installation.

##### Fully-Populated Configuration

Please follow the instructions below to populate all DIMM slots:

Processors and their Corresponding Memory Modules				
CPU#	Corresponding DIMM Modules for Full-Populated Configuration			
<b>CPU 1 (P1M1-)</b>	P1M1-DIMM A1/B1	P1M1-DIMM C1/D1	P1M1-DIMM A2/B2	P1M1-DIMM C2/D2
<b>CPU2 (P2M1-)</b>	P2M1-DIMM A1/B1	P2M1-DIMM C1/D1	P2M1-DIMM A2/B2	P2M1-DIMM C2/D2
<b>CPU3 (P3M1-)</b>	P3M1-DIMM A1/B1	P3M1-DIMM C1/D1	P3M1-DIMM A2/B2	P3M1-DIMM C2/D2
<b>CPU4 (P4M1-)</b>	P4M1-DIMM A1/B1	P4M1-DIMM C1/D1	P4M1-DIMM A2/B2	P4M1-DIMM C2/D2

##### Half-Populated Configuration

Please follow the instructions below to populate half of the DIMM slots:

Processors and their Corresponding Memory Modules		
CPU#	Corresponding DIMM Modules for Full-Populated Configuration	
<b>CPU 1 (P1M1-)</b>	P1M1-DIMM A1/B1	P1M1-DIMM C1/D1
<b>CPU2 (P2M1-)</b>	P2M1-DIMM A1/B1	P2M1-DIMM C1/D1
<b>CPU3 (P3M1-)</b>	P3M1-DIMM A1/B1	P3M1-DIMM C1/D1
<b>CPU4 (P4M1-)</b>	P4M1-DIMM A1/B1	P4M1-DIMM C1/D1

- **An Important Note:** For the memory modules to work properly, please install DIMM modules of the same type, same speed, and same operating frequency

**RDIMM/LRDIMM DDR4 ECC in Performance Mode (2:1)**

<b>DDR4 RDIMM+LRDIMM (2:1)</b>					
Type	Ranks Per DIMM & Data Width (x8 is supported, but not listed) SR=Single Rank DR=Dual Rank QR=Quad Rank	Max DIMM Capacity (GB)		Max Speed (MT/s); Voltage (V); Slot Per Channel (SPC) and DIMM Per Channel (DPC)	
				2SPC	
		4Gb	8Gb	1DPC	2DPC
RDIMM	SRx4	8GB	16GB	1600	1600
RDIMM	DRx4	16GB	32GB	1600	1600
LRDIMM	QRx4	32GB	64GB	1600	1600
LRDIMM 3DS	8Rx4	64GB	128GB	1600	1600

**RDIMM/LRDIMM DDR4 ECC in Lockstep Mode (1:1)**

<b>DDR4 RDIMM+LRDIMM (1:1)</b>					
Type	Ranks Per DIMM & Data Width (x8 is supported, but not listed) SR=Single Rank DR=Dual Rank QR=Quad Rank	Max DIMM Capacity (GB)		Max Speed (MT/s); Voltage (V); Slot Per Channel (SPC) and DIMM Per Channel (DPC)	
				2SPC	
		4Gb	8Gb	1DPC	2DPC
RDIMM	SRx4	8GB	16GB	1866	1866
RDIMM	DRx4	16GB	32GB	1866	1866
LRDIMM	QRx4	32GB	64GB	1866	1866
LRDIMM 3DS	8Rx4	64GB	128GB	1866	1866

## 2-6 Control Panel Connectors and I/O Ports

The I/O ports are color coded in conformance with the industry standards. See the picture below for the colors and locations of the various I/O ports.

### Back Panel Connectors and I/O Ports

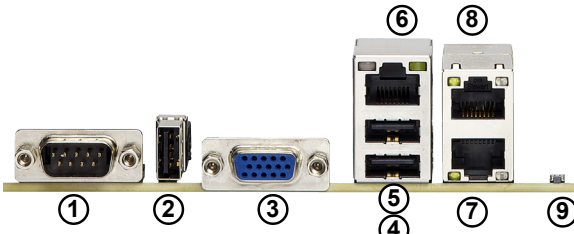
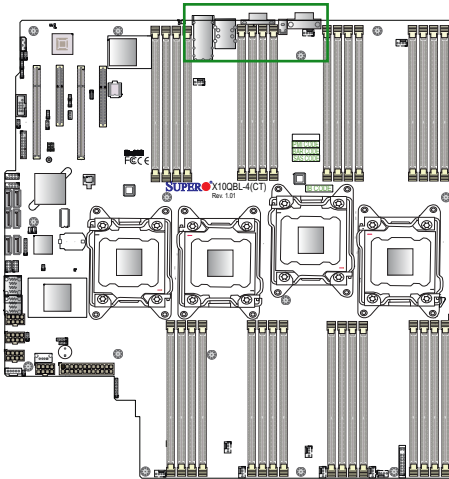

### Back Panel I/O Port Locations and Definitions

1. COM Port 1
2. Back Panel (Vertical) USB 2.0 Port 2
3. VGA (Blue)
4. Back Panel USB 2.0 Port 0
5. Back Panel USB 2.0 Port 1
6. IPMI_LAN
7. Gigabit_LAN 1 (X10QBL-4CT), 10G-LAN (TLAN) 1 (X10QBL-4)
8. Gigabit_LAN 2 (X10QBL-4CT), 10G-LAN (TLAN) 2 (X10QBL-4)
9. UID Switch/UID LED (LED1)

## COM Port/Serial Connection Header

A COM port (COM1) is located next to USB 2 on the I/O back panel. In addition, a serial port connection header (COM2) is located next to the PCI-E 3.0 x16 slot (CPU1 Slot1) on the motherboard. See the table on the right for pin definitions.

COM Port/Serial Header Pin Definitions			
Pin #	Definition	Pin #	Definition
1	DCD	6	DSR
2	RXD	7	RTS
3	TXD	8	CTS
4	DTR	9	RI
5	Ground	10	N/A

## Universal Serial Bus (USB)

Three USB2.0 ports (USB 0/1, USB 2) are located on the I/O back panel. Two internal USB headers, located next to the I-SATA ports 4/5, provide four USB 2.0 connections (USB 4/5, 6/7) for front access. In addition, a Type A USB header, located close to the 24-pin main power (JPWR1), also provides USB 2.0 connection (USB 8) for front panel support. (Cables are not included). See the tables below for pin definitions.

Back Panel USB 2.0 (USB 0/1) Pin Definitions			
Pin#	Definition	Pin#	Definition
1	+5V	5	+5V
2	USB_PN1	6	USB_PN0
3	USB_PP1	7	USB_PP0
4	Ground	8	Ground

Back panel USB 2 (2.0) Pin Definitions	
Pin#	Definition
1	+5V
2	PO-
3	PO+
4	Ground
5	NA

Front Panel USB 2.0 (USB 4/5, 6/7, 8) Pin Definitions			
Pin #	Definition	Pin #	Definition
1	+5V	2	+5V
3	USB_PN2	4	USB_PN3
5	USB_PP2	6	USB_PP3
7	Ground	8	Ground
9	Key	10	Ground

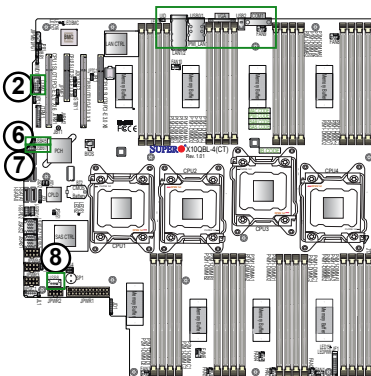

1. COM Port 1 (COM1)
2. Serial Port Header (COM2)
3. Backpanel USB0 (USB2.0)
4. Backpanel USB1 (USB2.0)
5. Backpanel USB2 (Vertical USB2.0)
6. Backpanel USB4/5 (USB2.0)
7. Backpanel USB6/7 (USB2.0)
8. Type A USB8 (USB 2.0)

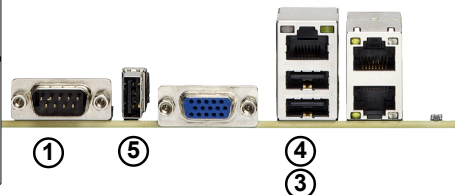

### Video Connection

A Video (VGA) port is located next to USB Port 2 on the I/O back panel. Refer to the motherboard layout below for the location.

### Ethernet Ports

Two Ethernet ports (LAN1, LAN2) are located on the I/O back panel. These Ethernet ports support 10G-LAN (TLAN) connections (10G-LAN 1/2) on the X10QBL-4CT, and gigabit LAN connections (GLAN 1/2) on the X10QBL-4. In addition, an IPMI\_LAN located on the back panel provides support for IPMI 2.0 interface. All Ethernet ports accept RJ45 type cables. Please refer to the LED Indicator section for LAN LED information.

LAN Ports Pin Definition			
Pin#	Definition		
1	P2V5SB	10	SGND
2	TD0+	11	Act LED
3	TD0-	12	P3V3SB
4	TD1+	13	Link 100 LED (Yellow, +3V3SB)
5	TD1-	14	Link 1000 LED (Yellow, +3V3SB)
6	TD2+	15	Ground
7	TD2-	16	Ground
8	TD3+	17	Ground
9	TD3-	18	Ground

(NC: No Connection)

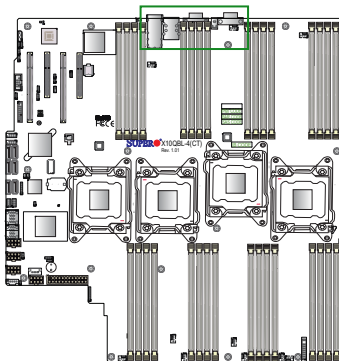

1. COM Port1
2. LAN1 (10G-LAN for X10QBL-4CT, GLAN for X10QBL-4)
3. LAN2 (10G-LAN for X10QBL-4CT, GLAN for X10QBL-4)
4. IPMI\_LAN (GLAN for X10QBL-4(CT))

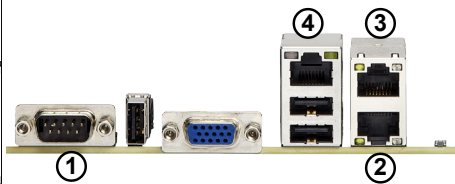

## Unit Identifier Switches/UID LED Indicators

A rear Unit Identifier (UID) switch (JUIDB1) and a rear LED (LE1) are located close to LAN ports 1/2 on the rear side of the motherboard. The front UID switch is located at pin 13 of the Front Control Panel (JF1), while the front UID LED is located on pin 7 of JF1. When you press the front UID switch or the rear one, both front and rear UID LEDs will be turned on. Press the UID button again to turn off the LED indicator. The UID Indicators provide easy identification of a system unit that may be in need of service.

 **Note:** UID can also be triggered via IPMI on the motherboard. For more information on IPMI, please refer to the IPMI User's Guide posted on our website @<http://www.supermicro.com>.

UID Switch	
Pin#	Definition
1	Ground
2	Ground
3	Button In
4	Ground

UID LED Status	
Color/State	Status
Blue: On	Unit Identified

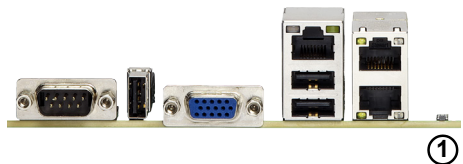
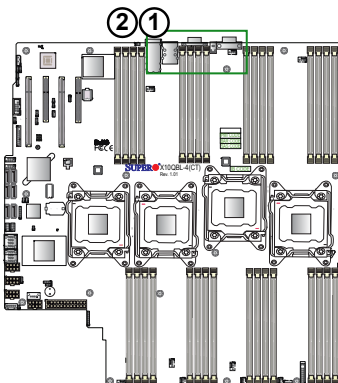
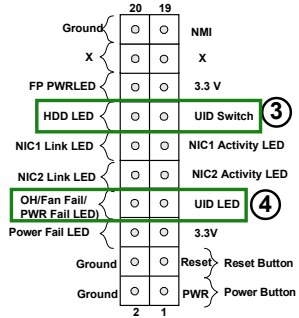

1. Rear UID Switch
2. Rear UID LED
3. Front UID Switch
4. Front UID LED

## Front Control Panel

JF1 contains header pins for various buttons and indicators that are normally located on a control panel at the front of the chassis. These connectors are designed specifically for use with Supermicro's server chassis. See the figure below for the descriptions of the various control panel buttons and LED indicators. Refer to the following section for descriptions and pin definitions.

### JF1 Header Pins

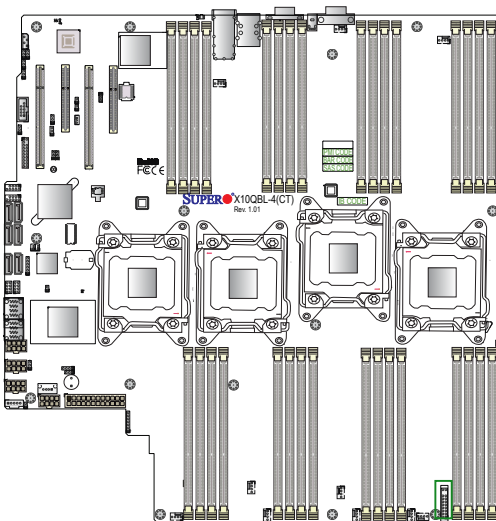
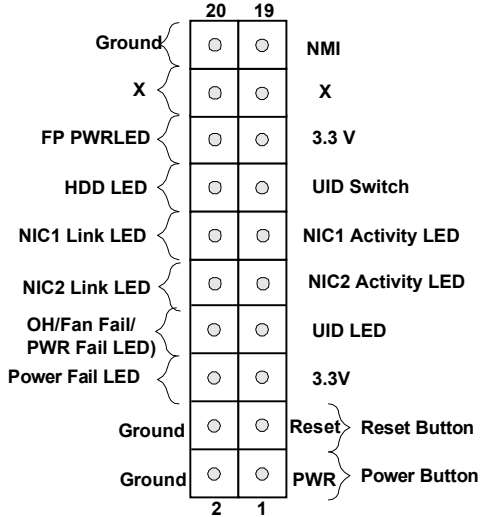

## Front Control Panel Pin Definitions

### NMI Button

The non-maskable interrupt button header is located on pins 19 and 20 of JF1. Refer to the table on the right for pin definitions.

NMI Button Pin Definitions (JF1)	
Pin#	Definition
19	Control
20	Ground

### Power LED

The Power LED connection is located on pins 15 and 16 of JF1. Refer to the table on the right for pin definitions.

Power LED Pin Definitions (JF1)	
Pin#	Definition
15	3.3V
16	PWR LED

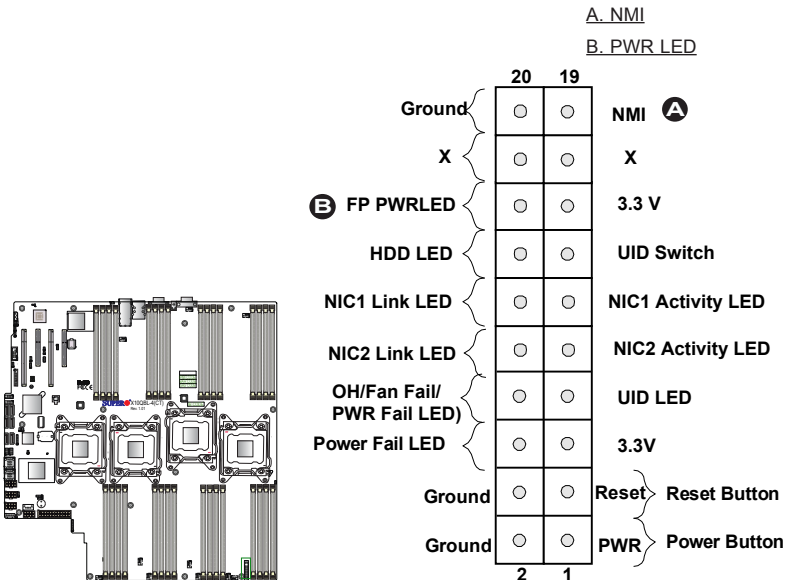

**HDD/UID LED**

The HDD LED connection is located on pins 13 and 14 of JF1. Attach a cable here to indicate HDD activity and UID status. See the table on the right for pin definitions.

HDD LED Pin Definitions (JF1)	
Pin#	Definition
13	UID LED
14	HD Active

**NIC1/NIC2 LED Indicators**

The NIC (Network Interface Controller) LED connection for LAN port 1 is located on pins 11 and 12 of JF1, and the LED connection for LAN port 2 is on pins 9 and 10. Attach the NIC LED cables here to display network activity. Refer to the table on the right for pin definitions.

GLAN1/2 LED Pin Definitions (JF1)	
Pin#	Definition
9	NIC 2 Activity LED
10	NIC 2 Link LED
11	NIC 1 Activity LED
12	NIC 1 Link LED

A. HDD/UID LED

B. NIC1 LED

C. NIC2 LED

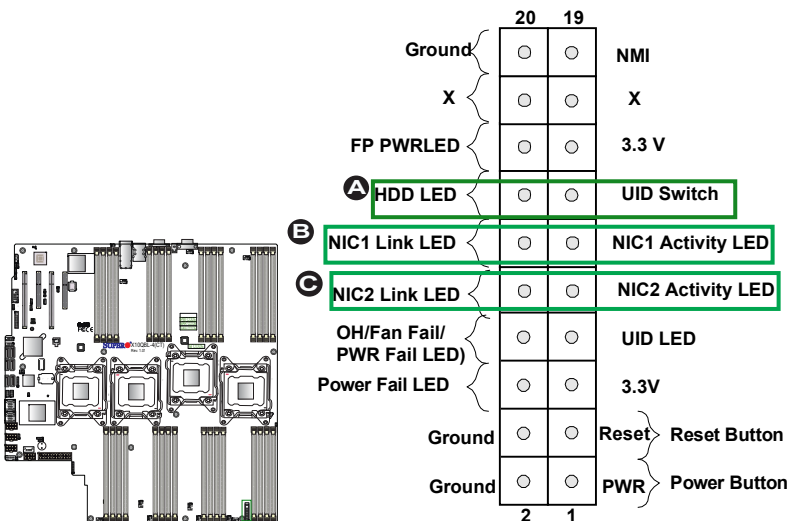

### Overheat (OH)/Fan Fail/PWR Fail/UID LED

Connect an LED cable to pins 7 and 8 of JF1 to use the Overheat/Fan Fail/Power Fail and UID LED connections. The red LED on pin 8 provides warnings for overheating, fan failure or power failure. The blue LED on pin 7 works as the front panel UID LED indicator. Refer to the table on the right for pin definitions.

OH/Fan Fail/ PWR Fail/Blue_UID LED Pin Definitions (JF1)	
Pin#	Definition
7	Blue_UID LED
8	OH/Fan Fail/Power Fail

OH/Fan Fail/PWR Fail LED Status (Red LED)	
State	Definition
Off	Normal
On	Overheat
Flashing	Fan Fail

### Power Fail LED

The Power Fail LED connection is located on pins 5 and 6 of JF1. Refer to the table on the right for pin definitions.

PWR Fail LED Pin Definitions (JF1)	
Pin#	Definition
5	3.3V
6	PWR Supply Fail

A. OH/Fail/PWR Fail LED

B. PWR Supply Fail

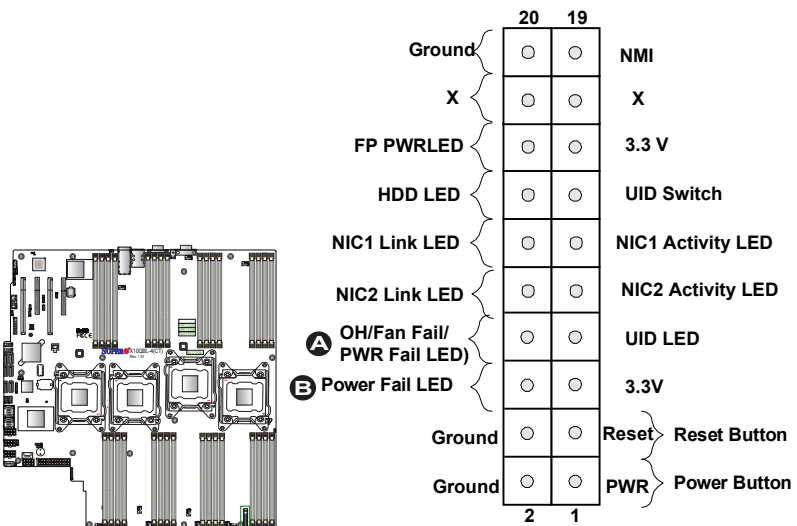

**Reset Button**

The Reset Button connection is located on pins 3 and 4 of JF1. Attach it to a hardware reset switch on the computer case. Refer to the table on the right for pin definitions.

Reset Button Pin Definitions (JF1)	
Pin#	Definition
3	Reset
4	Ground

**Power Button**

The Power Button connection is located on pins 1 and 2 of JF1. Momentarily contacting both pins will power on/off the system. To turn on or off the system power, press the button for 4 seconds or longer. Refer to the table on the right for pin definitions.

Power Button Pin Definitions (JF1)	
Pin#	Definition
1	Signal
2	Ground

A. Reset Button

B. PWR Button

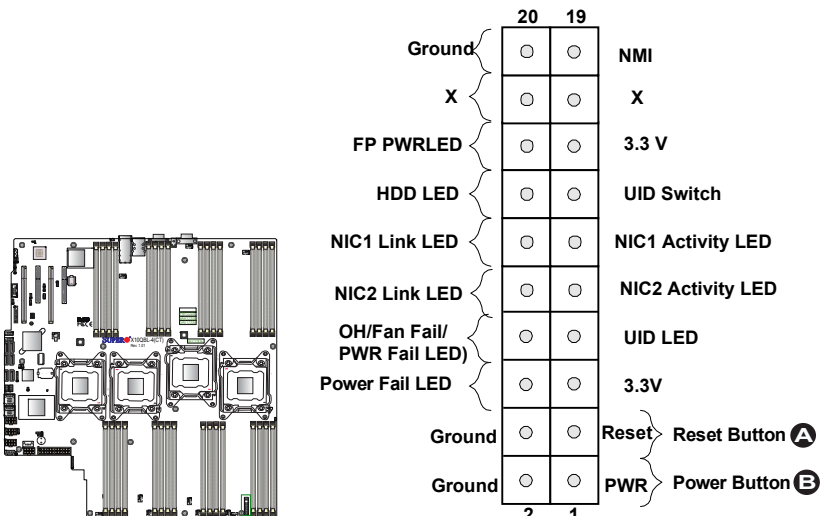

## 2-7 Connecting Cables

### Power Connectors

A 24-pin main power supply connector (JPWR1), and four 8-pin CPU power connectors (JPWR2/JPWR3/JPWR4/JPWR5) are located on the motherboard. These power connectors meet the SSI EPS 12V specification and must be connected to your power supply to provide adequate power to the system. See the tables on the right for pin definitions.

**Warning:** To provide adequate power supply to the motherboard, be sure to connect the 24-pin ATX PWR (JPWR1), and the *four* 8-pin PWR connectors (JPWR2/3/4/5) to the power supply. Failure to do so may void the manufacturer warranty on your power supply and motherboard.

ATX Power 24-pin Connector Pin Definitions			
Pin#	Definition	Pin #	Definition
13	+3.3V	1	+3.3V
14	-12V	2	+3.3V
15	GND	3	GND
16	PS_ON	4	+5V
17	GND	5	GND
18	GND	6	+5V
19	GND	7	GND
20	-5V	8	PWR_OK
21	+5V	9	5VSB
22	+5V	10	+12V
23	+5V	11	+12V
24	GND	12	+3.3V

12V 8-pin Power Connector Pin Definitions	
Pins	Definition
1 through 4	Ground
5 through 8	+12V

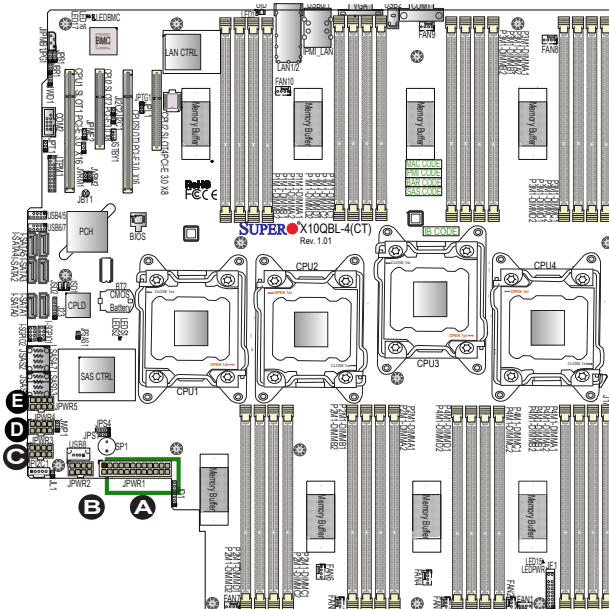

- A. JPWR1 (24-pin PWR)
- B. JPWR2 (8-pin PWR)
- C. JPWR3 (8-pin PWR)
- D. JPWR4 (8-pin PWR)
- E. JPWR5 (8-pin PWR)

**Fan Headers**

This motherboard has ten system/CPU fan headers (Fan1-Fan10) on the motherboard. These 4-pin fan headers are backward compatible with the traditional 3-pin fans. However, fan speed control is available for 4-pin fans only by thermal management via IPMI 2.0 interface. See the table on the right for pin definitions.

Fan Header Pin Definitions	
Pin#	Definition
1	Ground
2	+12V
3	Tachometer
4	PWR Modulation

**IPMB**

A System Management Bus header for IPMI 2.0 is located at JIPMB1. Connect an appropriate cable here to use the IPMB I<sup>2</sup>C connection on your system.

IPMB Header Pin Definitions	
Pin#	Definition
1	Data
2	Ground
3	Clock
4	No Connection

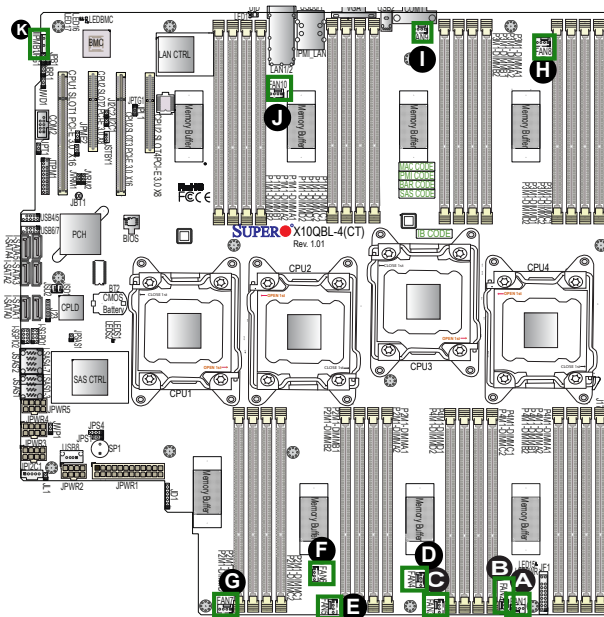

- A. Fan 1
- B. Fan 2
- C. Fan 3
- D. Fan 4
- E. Fan 5
- F. Fan 6
- G. Fan 7
- H. Fan 8
- I. Fan 9
- J. Fan 10
- K. JIPMB1

### TPM/Port 80 Header

A Trusted Platform Module/Port 80 header, located at JTPM1, provides TPM support and Port 80 connection. Use this header to enhance system performance and data security. See the table on the right for pin definitions.

TPM/Port 80 Header Pin Definitions			
Pin #	Definition	Pin #	Definition
1	LCLK	2	GND
3	LFRAME#	4	<(KEY)>
5	LRESET#	6	+5V (X)
7	LAD 3	8	LAD 2
9	+3.3V	10	LAD1
11	LAD0	12	GND
13	SMB_CLK4	14	SMB_DAT4
15	+3V_DUAL	16	SERIRQ
17	GND	18	CLKRUN# (X)
19	LPCPD#	20	LDRQ# (X)

### SATA DOM Power Connectors

Two power connectors for SATA DOM (Disk\_On\_Module) devices are located at JSD1/JSD2. Connect appropriate cables here to provide power support for your Serial-Link DOM devices.

DOM PWR Pin Definitions	
Pin#	Definition
1	+5V
2	Ground
3	Ground

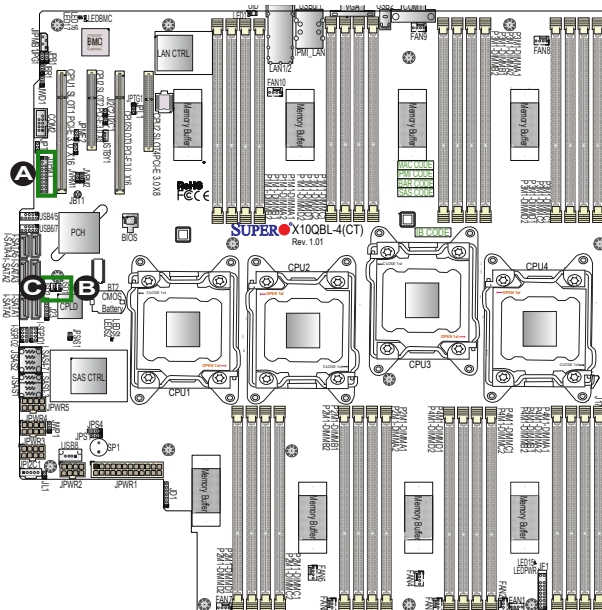

A. TPM/80 Port

B. JSD1

C. JSD2

**Chassis Intrusion**

A Chassis Intrusion header is located at JL1 on the motherboard. Attach an appropriate cable from the chassis to inform you of a chassis intrusion when the chassis is opened.

Chassis Intrusion Pin Definitions	
Pin#	Definition
1	Intrusion Input
2	Ground

**Internal Speaker**

The Internal Speaker (SP1) can be used to provide audible indications for various beep codes. See the table on the right for pin definitions. Refer to the layout below for the location of the internal buzzer.

Internal Buzzer Pin Definition		
Pin#	Definitions	
Pin 1	Pos. (+)	Power (5V)
Pin 2	Neg. (-)	Alarm Speaker

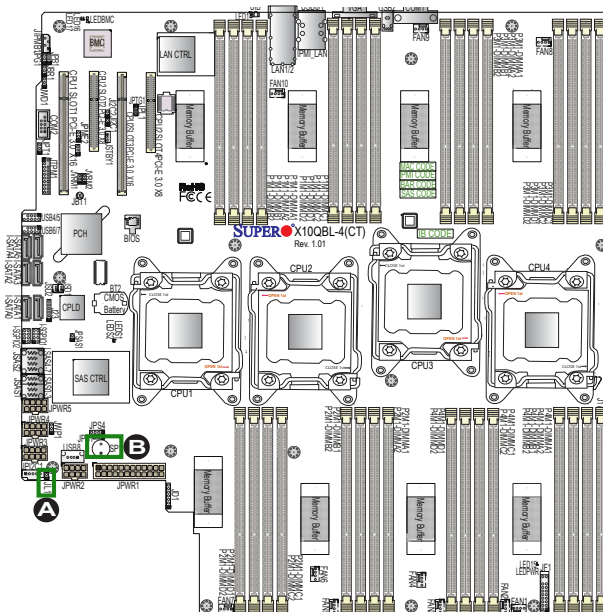

A. Chassis Intrusion

B. Internal Speaker

### I-SGPIO 1/2 Headers

Two SGPIO (Serial\_Link General Purpose Input/Output) headers are located on the motherboard. I-SGPIO1/2 supports onboard SATA connections on the X10QBL-4(CT). See the table on the right for pin definitions.

I-SGPIO Headers Pin Definitions			
Pin#	Definition	Pin	Definition
1	NC	2	NC
3	Ground	4	Data
5	Load	6	Ground
7	Clock	8	NC

**Note:** NC= No Connection

### Power LED/Speaker

Pins 1-3 of JD1 are used for power LED indication, and pins 4-7 are for the speaker. Please note that the speaker connector pins (4-7) are used with an external speaker. To use the onboard speaker, please close pins 6-7 with a cap. See the tables on the right for pin definitions.

PWR LED Connector Pin Definitions	
Pin Setting	Definition
Pin 1	JD1_PIN1
Pin 2	FP_PWR_LED
Pin 3	FP_PWR_LED

Speaker Connector Pin Settings	
Pin Setting	Definition
Pin 4	P5V
Pin 5	Key
Pin 6	R_SPKPIN_N
Pin 7	R_SPKPIN

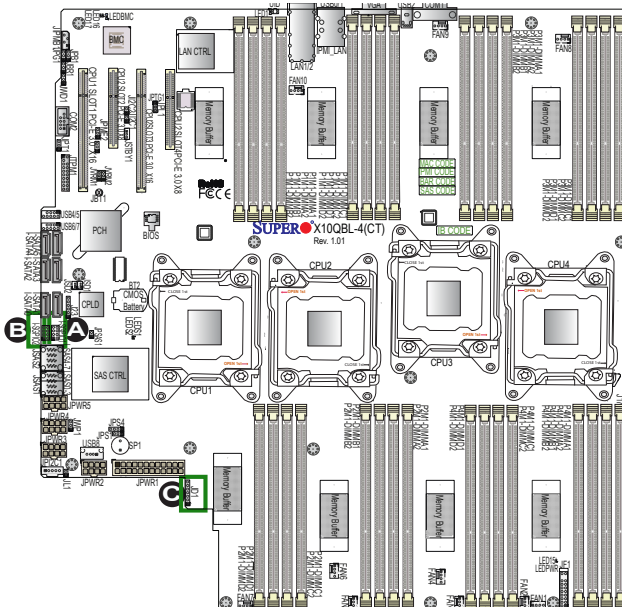

A. I-SGPIO1

B. I-SGPIO2

C. JD1

**Standby Power Header**

The +5V Standby Power header is located at JSTBY1 on the motherboard. See the table on the right for pin definitions. (You must also have a card with a standby power connector and a cable to use this feature.)

Standby PWR Pin Definitions	
Pin#	Definition
1	+5V Standby
2	Ground
3	No Connection

**Power SMB (I<sup>2</sup>C) Connector**

Power System Management Bus (I<sup>2</sup>C) connector (JPI<sup>2</sup>C1) monitors power supply, fan and system temperatures. See the table on the right for pin definitions.

PWR SMB Pin Definitions	
Pin#	Definition
1	Clock
2	Data
3	PMBUS_Alert
4	Ground
5	+3.3V

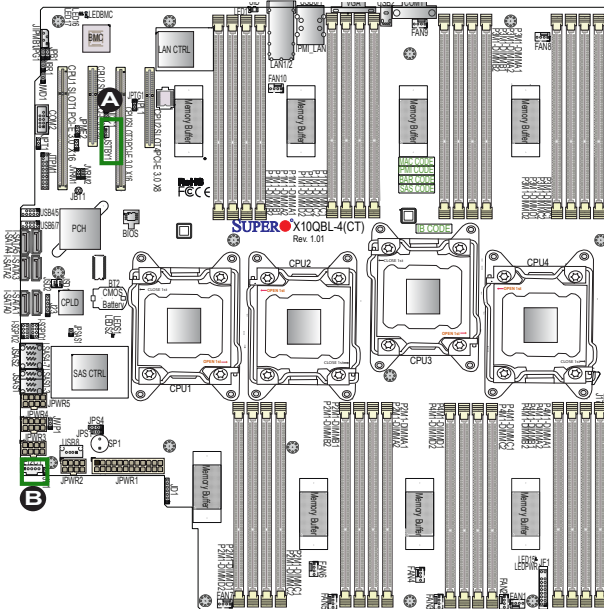



- A. STBY1
- B. JPI<sup>2</sup>C1

## 2-8 Jumper Settings

### Explanation of Jumpers

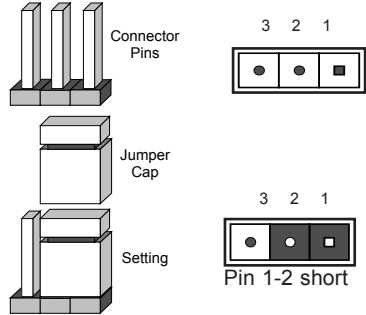
To modify the operation of the motherboard, jumpers can be used to choose between optional settings. Jumpers create shorts between two pins to change the function of the connector. Pin 1 is identified with a square solder pad on the printed circuit board. See the motherboard layout pages for jumper locations.



 **Note:** On two pin jumpers, "Closed" means the jumper is on, and "Open" means the jumper is off the pins.

### LAN Enable/Disable

JPL1 enables or disables Gigabit\_LAN ports on the X10QBL-4CT, while JPTG1 enables or disables 10G-LAN ports on the X10QBL-4-T. See the table on the right for jumper settings. The default setting is Enabled.

LAN Enable Jumper Settings	
Jumper Setting	Definition
Pins 1-2	Enabled (default)
Pins 2-3	Disabled

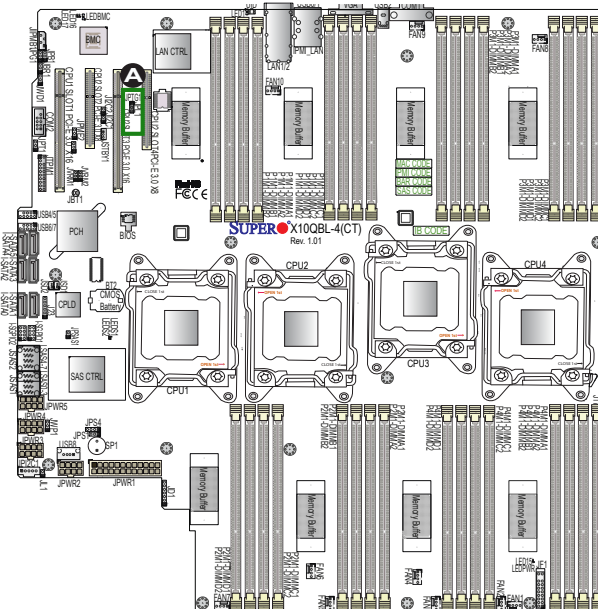

- A. JPL1: GLAN1/2 Enable (X10QBL-4)
- A. JPTG1: 10G-LAN1/2 Enable (X10QBL-4CT)

### CMOS Clear

JBT1 is used to clear CMOS. Instead of pins, this "jumper" consists of contact pads to prevent accidental clearing of CMOS. To clear CMOS, use a metal object such as a small screwdriver to touch both pads at the same time to short the connection.

 **Note.** You must completely shut down the system, and then short JBT1 to clear CMOS.



### Watch Dog Enable/Disable

Watch Dog (JWD1) is a system monitor that will reboot the system when a software application hangs. Close pins 1-2 to reset the system if an application hangs. Close pins 2-3 to generate a non-maskable interrupt signal for the application that hangs. See the table on the right for jumper settings. Watch Dog must also be enabled in the BIOS.

Watch Dog Jumper Settings	
Jumper Setting	Definition
Pins 1-2	Reset (default)
Pins 2-3	NMI
Open	Disabled

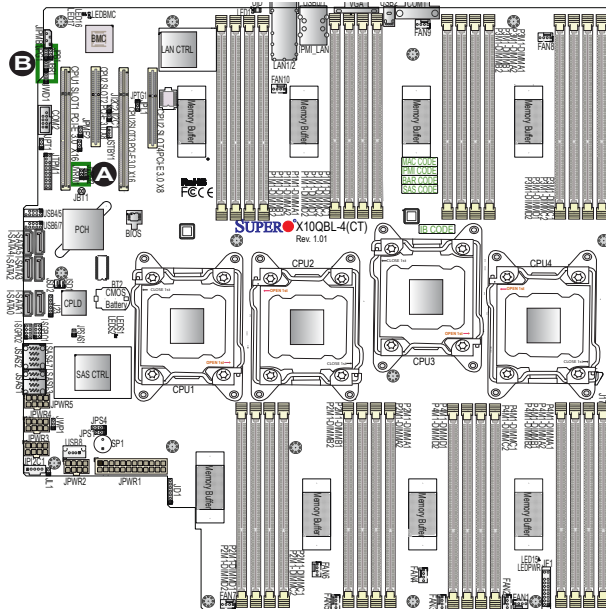

- A. Clear CMOS
- B. Watch Dog Enable

## VGA Enable

Jumper JPG1 allows the user to enable the onboard VGA connector. The default setting is on pins 1-2 to enable the connection. See the table on the right for jumper settings.

VGA Enable Jumper Settings	
Jumper Setting	Definition
Pins 1-2	Enabled (Default)
Pins 2-3	Disabled

## BMC Enable

Jumper JPB1 is used to enable or disable the embedded ASpeed AST2400 BMC (Baseboard Management Controller) that provides IPMI 2.0/KVM support on the motherboard. See the table on the right for jumper settings.

BMC Enable Jumper Settings	
Jumper Setting	Definition
Pins 1-2	BMC Enable (Default)
Pins 2-3	Disabled

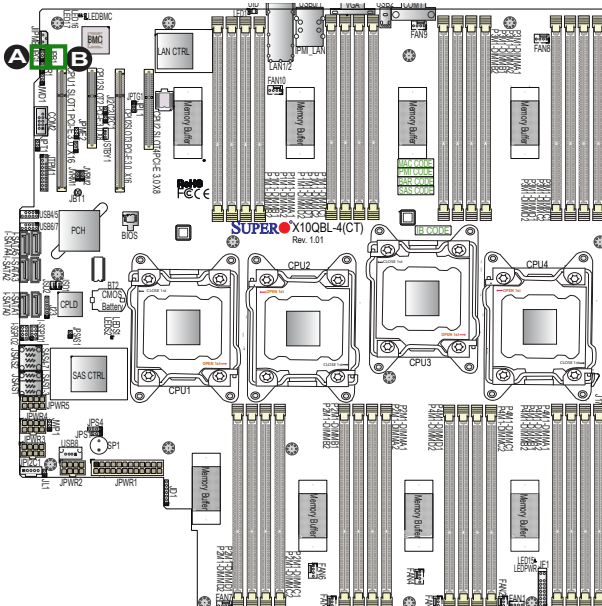

A. VGA Enabled

B. BMC Enabled

**I<sup>2</sup>C Bus to PCI-Exp. Slots**

Use Jumpers JI<sup>2</sup>C1 and JI<sup>2</sup>C2 to connect the System Management Bus (I<sup>2</sup>C) to the PCI-Express slots to improve PCI performance. These two jumpers are to be set at the same time. The default setting is pins 2-3 to disable the connection for normal operations. See the table on the right for jumper settings.

I <sup>2</sup> C for PCI-E slots Jumper Settings	
Jumper Setting	Definition
Pins 1-2	Enabled
Pins 2-3	Disabled (Default)

**TPM Support Enable**

JPT1 allows the user to enable TPM (Trusted Platform Modules) support to enhance data integrity and system security. See the table on the right for jumper settings. The default setting is enabled.

TPM Enable Jumper Settings	
Jumper Setting	Definition
Pins 1-2	Enabled (Default)
Pins 2-3	Disabled

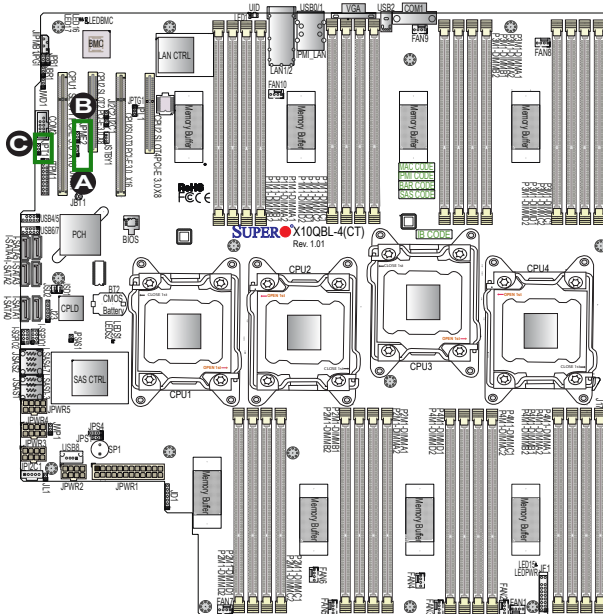

- A. JI<sup>2</sup>C1
- B. JI<sup>2</sup>C2
- C. JPT1

### Manufacturer Mode Select

Close pin 2 and pin 3 of Jumper JPME2 to bypass SPI flash security and force the system to operate in the Manufacturer mode, which will allow the user to flash the system firmware from a host server for system setting modifications. See the table on the right for jumper settings.

ME Mode Select Jumper Settings	
Jumper Setting	Definition
Pins 1-2	Normal (Default)
Pins 2-3	Manufacture Mode

### SAS Enable (for X10QBL-4CT only)

Use Jumper JPS1 to enable or disable onboard SAS connections (L-SAS 0-3, 4-7) on the X10QBL-4CT. The default setting is on pins 1/2 to enable SAS support. See the table on the right for jumper settings.

SAS Enable Jumper Settings	
Jumper Setting	Definition
Pins 1-2	Enabled (Default)
Pins 2-3	Disabled

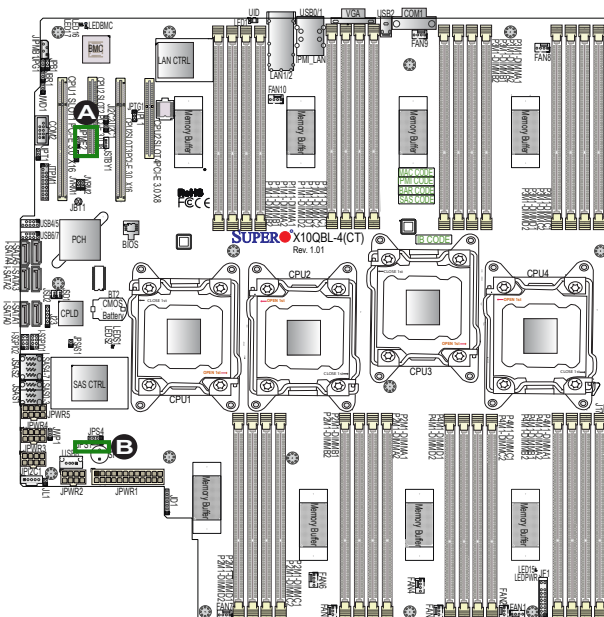

A. JPME2

B. JPS1 (X10QBL-4CT only)

**SAS HDD Status Support Enable  
(for X10QBL-4CT only)**

Put a cap on Jumper JPSAS1 to enable onboard SAS HDD status support on the X10QBL-4CT. The default setting is to disable this function by keeping the cap off from the jumper. See the table on the right for jumper settings.

SAS HDD Status Support Enable Jumper Settings	
Jumper Setting	Definition
On	Enabled
Off	Disabled (Default)

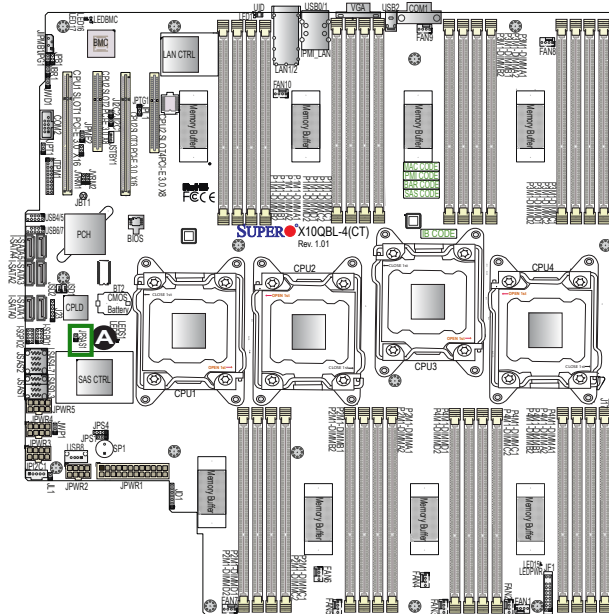

A. JPSAS1  
(X10QBL-4CT  
only)

## 2-9 Onboard LED Indicators

### LAN LEDs

Two LAN ports (LAN1/LAN2) are located on the IO back panel on the motherboard. Each Ethernet LAN port has two LEDs. The yellow LED indicates activity. Link LED, located on the left side of the LAN port, may be green, amber or off indicating the speed of the connection. See the tables at right for more information.



**Rear View** (when facing the rear side of the chassis)

GLAN Activity Indicator (Left) LED Settings		
Color	Status	Definition
Yellow	Flashing	Active

10G-LAN Link LEDs LED Settings (for X10QBL-4CT)	
LED Color	Definition
Off	No Connection, 10 or 100 Mbps
Green	10 Gbps
Amber	1 Gbps

GLAN Link LEDs LED Settings (for X10QBL-4)	
LED Color	Definition
Off	No Connection, or 10 Mbps
Green	100 Mbps
Amber	1 Gbps

### IPMI\_LAN LEDs

In addition to LAN 1/LAN 2, an IPMI-dedicated LAN is located on the I/O back panel of the motherboard. The amber LED on the right indicates activity, while the green LED on the left indicates the speed of the connection. See the tables at right for more information.

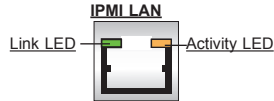

IPMI LAN Link LED (Left) & Activity LED (Right)		
	Color/State	Definition
Link (Left)	Green: Solid: 100 Mbps Amber: Solid: 1 Gbps	
Activity (Right)	Amber: Blinking	Active

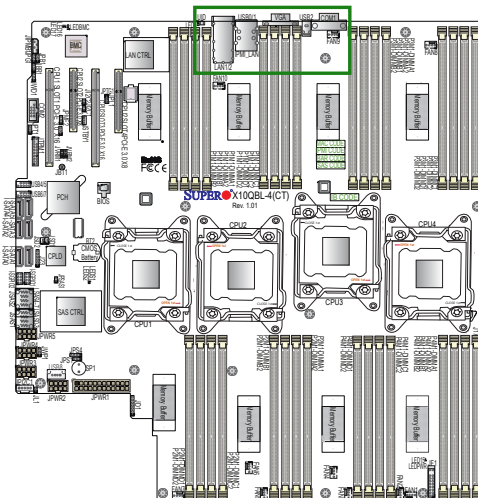

A. LAN1/2 LEDs

B. IPMI LAN LEDs



**Onboard Power LED**

An Onboard Power LED indicator is located at LED15 (LEDPWR) on the motherboard. When this LED is on, the system is on. Be sure to turn off the system and unplug the power cord before removing or installing components. See the tables at right for more information.

Onboard PWR LED Indicator LED States	
LED Color	Definition
Off	System Off (PWR cable not connected)
Green	System On

**BMC Heartbeat LED**

A BMC Heartbeat LED is located at LEDBMC on the motherboard. When LEDBMC is blinking, BMC functions normally. See the table at right for more information.

BMC Heartbeat LED States	
Color/State	Definition
Green: Blinking	BMC: Normal

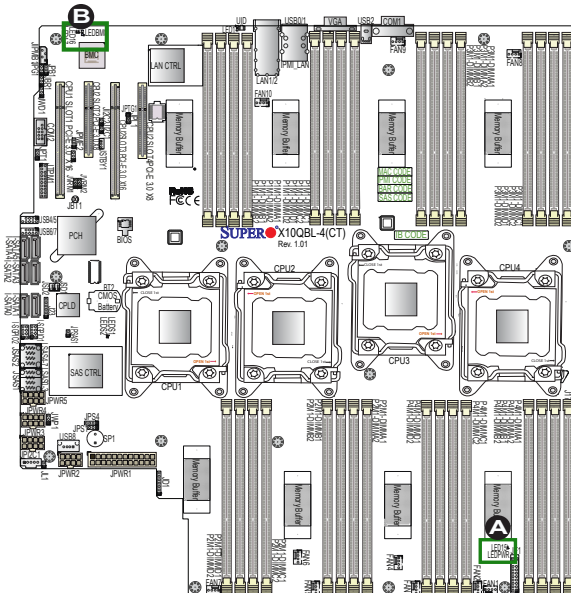

A. PWR LED

B. BMC LED

### SAS Heartbeat LED (for X10QBL-4CT only)

A SAS Heartbeat LED is located at LEDS1 on the motherboard. When LEDS1 is blinking, the SAS is functioning normally. See the table at right for more information.

SAS Heartbeat LED Status	
Color/State	Definition
Green: On	SAS: Normal
Red: On	SAS: Failed

### SAS Activity LED (for X10QBL-4CT only)

A SAS Activity LED is located at LEDS2 on the motherboard. When LEDS2 is blinking, the SAS is active.

SAS Activity LED States	
Color/State	Definition
Green: Blinking	SAS: Active

 **Note:** Refer to Page 2-19 for information on the UID LED (UID\_LED1).

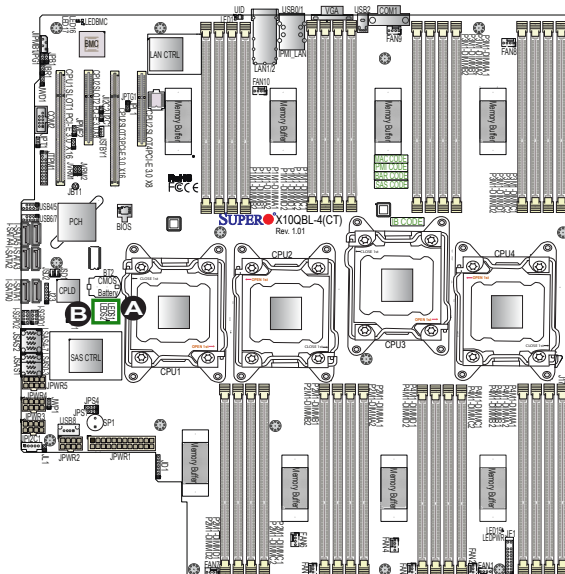

A. SAS Heartbeat LED (X10QBL-4CT)  
B. SAS Activity LED (X10QBL-4CT)

## 2-10 SATA/SAS 3.0 Connections

### SATA 3.0 Ports

Six SATA connections supported by Intel PCH 602 are located on the motherboard. I-SATA ports 0/1 support SATA 3.0 connections, while I-SATA ports 2-5 support SATA 2.0. In addition, I-SATA0/1 are used with Supermicro SuperDOM (Disk-on-Module) connectors, which are yellow SATADOM connectors with power pins built-in and do not require separate external power cables. These connectors are back-compatible with non-Supermicro SATADOMs that require external power supply. SATA ports provide serial-link connections, which are faster than the connections of Parallel ATA. These SATA connectors provide serial-link connections, which are faster than Parallel ATA connections. See the table on the right for pin definitions.

SATA 2.0/3.0 Pin Definitions	
Pin#	Signal
1	Ground
2	SATA_TXP
3	SATA_TXN
4	Ground
5	SATA_RXN
6	SATA_RXP
7	Ground

### SAS 3.0 Ports (for X10QBL-4CT only)

Eight SAS 3.0 connections (L-SAS 0-3, 4-7) supported by the LSI 3008 SAS controller are located on the motherboard. The SAS connections are faster than traditional SATA connections.



**Note:** For more information on SATA HostRAID configuration, please refer to the Intel SATA HostRAID User's Guide posted on our website @ <http://www.supermicro.com>.

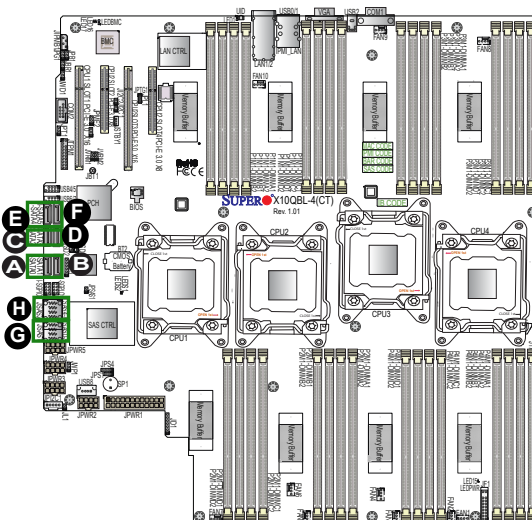

- A. I-SATA0
- B. I-SATA1
- C. I-SATA2
- D. I-SATA3
- E. I-SATA4
- F. I-SATA5
- G. L-SAS0-3  
(X10QBL-4CT Only)
- H. L-SAS4-7  
(X10QBL-4CT Only)

## Chapter 3

# Troubleshooting

### 3-1 Troubleshooting Procedures

Use the following procedures to troubleshoot your system. If you have followed all of the procedures below and still need assistance, refer to the "Technical Support Procedures" and/or "Returning Merchandise for Service" section(s) in this chapter.



**Note:** Always disconnect the power cord before adding, changing, or installing any hardware components.

#### Before Power On

1. Make sure that there are no short circuits between the motherboard and chassis.
2. Disconnect all ribbon/wire cables from the motherboard, including those for the keyboard and mouse.
3. Remove all add-on cards.
4. Install CPU 1 first (making sure it is fully seated) and connect the front panel connectors to the motherboard.

#### No Power

1. Make sure that there are no short circuits between the motherboard and the chassis.
2. Make sure that the ATX power connectors are properly connected.
3. Check that the 115V/230V switch on the power supply is properly set, if available.
4. Turn the power switch on and off to test the system, if applicable.
5. The battery on your motherboard may be old. Check to verify that it still supplies ~3VDC. If it does not, replace it with a new one.

## **No Video**

1. If the power is on but you have no video, remove all the add-on cards and cables.
2. Use the speaker to determine if any beep codes exist. Refer to Appendix A for details on beep codes.

## **System Boot Failure**

If the system does not display POST or does not respond after the power is turned on, check the following:

1. Check for any error beep from the motherboard speaker.
  - If there is no error beep, try to turn on the system without DIMM modules installed. If there is still no error beep, try to turn on the system again with only one processor installed in CPU Socket#1. If there is still no error beep, replace the motherboard.
  - If there are error beeps, clear the CMOS settings by unplugging the power cord and contacting both pads on the CMOS Clear Jumper (JBT1). (Refer to Section 2-8 in Chapter 2.)
2. Remove all components from the motherboard, especially the DIMM modules. Make sure that system power is on, and that memory error beeps are activated.
3. Turn on the system with only one DIMM module installed. If the system boots, check for bad DIMM modules or slots by following the Memory Errors Troubleshooting procedure in this Chapter.

## **Losing the System's Setup Configuration**

1. Make sure that you are using a high-quality power supply. A poor-quality power supply may cause the system to lose the CMOS setup information. Refer to Section 1-6 for details on recommended power supplies.
2. The battery on your motherboard may be old. Check to verify that it still supplies ~3VDC. If it does not, replace it with a new one.
3. If the above steps do not fix the setup configuration problem, contact your vendor for repairs.

## Memory Errors

If a "no memory" beep code is issued by the system, check the following:

1. Make sure that the memory modules are compatible with the system and that the DIMM modules are properly and fully installed. (For memory compatibility, refer to the Memory Compatibility Chart posted on our website @ <http://www.supermicro.com>.)
2. Check if different speeds of DIMMs have been installed. It is strongly recommended that you use the same RAM type and speed for all DIMMs in the system.
3. Make sure that you are using the correct type of Registered (RDIMM)/Load Reduction (LRDIMM) DDR4 ECC modules recommended by the manufacturer.
4. Check for bad DIMM modules or slots by swapping a single module among all memory slots and check the results.
5. Make sure that all memory modules are fully seated in their slots. Follow the instructions given in Section 2-5 in Chapter 2.
6. Please follow the instructions given in the DIMM population tables listed in Section 2-5 to install your memory modules.

## When the System Becomes Unstable

***A. If the system becomes unstable during or after OS installation, check the following:***

1. CPU/BIOS support: Make sure that your CPU is supported and you have the latest BIOS installed in your system.
2. Memory support: Make sure that the memory modules are supported by testing the modules using memtest86 or a similar utility.



**Note:** Refer to the product page on our website <http://www.supermicro.com> for memory and CPU support and updates.

3. HDD support: Make sure that all hard disk drives (HDDs) work properly. Replace the bad HDDs with good ones.
4. System cooling: Check system cooling to make sure that all heatsink fans, and CPU/system fans, etc., work properly. Check hardware monitoring set-

tings in the IPMI to make sure that the CPU and system temperatures are within the normal range. Also check the front-panel Overheat LED is not on.

5. Adequate power supply: Make sure that the power supply provides adequate power to the system. Make sure that all power connectors are connected. Please refer to our website for more information on minimum power requirements.
6. Proper software support: Make sure that the correct drivers are used.

***B. When the system becomes unstable before or during OS installation, check the following:***

1. Source of installation: Make sure that the devices used for installation are working properly, including boot devices such as CD/DVD disc.
2. Cable connection: Check to make sure that all cables are connected and working properly.
3. Using minimum configuration for troubleshooting: Remove all unnecessary components (starting with add-on cards first), and use minimum configuration (with a CPU and a memory module installed) to identify the trouble areas. Refer to the steps listed in Section A above for proper troubleshooting procedures.
4. Identifying bad components by isolating them: If necessary, remove a component in question from the chassis, and test it in isolation to make sure that it works properly. Replace a bad component with a good one.
5. Check and change one component at a time instead of changing several items at the same time. This will help isolate and identify the problem.
6. To find out if a component is good, swap this component with a new one to see if the system will work properly. If so, then the old component is bad. You can also install the component in question in another system. If the new system works, the component is good and the old system has problems.

## 3-2 Technical Support Procedures

Before contacting Technical Support, please take the following steps. Also, please note that as a motherboard manufacturer, Supermicro also sells motherboards through its channels, so it is best to first check with your distributor or reseller for troubleshooting services. They should know of any possible problem(s) with the specific system configuration that was sold to you.

1. Please go through the "Troubleshooting Procedures" and "Frequently Asked Question" (FAQ) sections in this chapter or see the FAQs on our website (<http://www.supermicro.com/>) before contacting Technical Support.
  2. BIOS upgrades can be downloaded from our website (<http://www.supermicro.com>).
  3. If you still cannot resolve the problem, include the following information when contacting Supermicro for technical support:
    - Motherboard model and PCB revision number
    - BIOS release date/version (This can be seen on the initial display when your system first boots up.)
    - System configuration
  4. An example of a Technical Support form is on our website at (<http://www.supermicro.com>).
- Distributors: For immediate assistance, please have your account number ready when placing a call to our technical support department. We can be reached by e-mail at [support@supermicro.com](mailto:support@supermicro.com).

### 3-3 Battery Removal and Installation

#### Battery Removal

To remove the onboard battery, follow the steps below:

1. Power off your system and unplug your power cable.
2. Locate the onboard battery as shown below.
3. Using a tool such as a pen or a small screwdriver, push the battery lock outwards to unlock it. Once unlocked, the battery will pop out from the holder.
4. Remove the battery.

#### Proper Battery Disposal

**Warning:** Please handle used batteries carefully. Do not damage the battery in any way; a damaged battery may release hazardous materials into the environment. Do not discard a used battery in the garbage or a public landfill. Please comply with the regulations set up by your local hazardous waste management agency to dispose of your used battery properly.

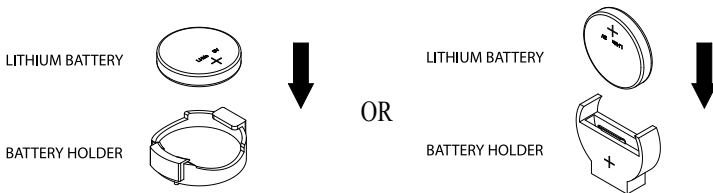

## 3-4 Frequently Asked Questions

**Question: What are the various types of memory that my board can support?**

**Answer:** The board supports Registered (RDIMM)/Load Reduction (LRDIMM) ECC DDR4 DIMM modules. To enhance memory performance, do not mix memory modules of different speeds and sizes. Please follow all memory installation instructions given on Section 2-5 in Chapter 2.

**Question: How do I update my BIOS?**

It is recommended that you **do not** upgrade your BIOS if you are not experiencing any problems with your system. Updated BIOS files are located on our website at <http://www.supermicro.com>. Please check our BIOS warning message and the information on how to update your BIOS on our website. Select your motherboard model and download the BIOS file to your computer. Also, check the current BIOS revision to make sure that it is newer than your BIOS before downloading. You can choose from the zip file and the .exe file. If you choose the zip BIOS file, please unzip the BIOS file onto a bootable USB device. Run the batch file using the format FLASH.bat filename.rom from your bootable USB device to flash the BIOS. Then your system will automatically reboot.

**Warning:** Do not shut down or reset the system while updating the BIOS to prevent possible system boot failure!



**Note:** The SPI BIOS chip used on this motherboard cannot be removed. Send your motherboard back to our RMA Department at Supermicro for repair. For BIOS recovery instructions, please refer to the AMI BIOS Recovery Instructions posted at <http://www.supermicro.com>.

**Question: How do I handle the used battery?**

**Answer:** Please handle used batteries carefully. Do not damage the battery in any way; a damaged battery may release hazardous materials into the environment. Do not discard a used battery in the garbage or a public landfill. Please comply with the regulations set up by your local hazardous waste management agency to dispose of your used battery properly.

### 3-5 Returning Merchandise for Service

A receipt or copy of your invoice marked with the date of purchase is required before any warranty service will be rendered. You can obtain service by calling your vendor for a Returned Merchandise Authorization (RMA) number. When returning the motherboard to the manufacturer, the RMA number should be prominently displayed on the outside of the shipping carton, and the shipping package is mailed prepaid or hand-carried. Shipping and handling charges will be applied for all orders that must be mailed when service is complete. For faster service, you can also request an RMA authorization online (<http://www.supermicro.com/RmaForm/>).

This warranty only covers normal consumer use and does not cover damages incurred in shipping or from failure due to the alternation, misuse, abuse, or improper maintenance of products.

During the warranty period, contact your distributor first for any product problems.

## Chapter 4

# BIOS

### 4-1 Introduction

This chapter describes the AMI BIOS setup utility for the X10QBL-4CT/X10QBL-4. It also provides the instructions on how to navigate the AMI BIOS setup utility screens. The AMI ROM BIOS is stored in a Flash EEPROM and can be easily updated.

#### Starting BIOS Setup Utility

To enter the AMI BIOS setup utility screens, press the <Del> key while the system is booting up.

 **Note:** In most cases, the <Del> key is used to invoke the AMI BIOS setup screen. There are a few cases when other keys are used, such as <F3>, <F4>, etc.

Each main BIOS menu option is described in this manual. The Main BIOS setup menu screen has two main frames. The left frame displays all the options that can be configured. Grayed-out options cannot be configured. Options in blue can be configured by the user. The right frame displays the key legend. Above the key legend is an area reserved for informational text. When an option is selected in the left frame, it is highlighted in white. Often informational text will accompany it.

 **Note:** The AMI BIOS has default informational messages built in. The manufacturer retains the option to include, omit, or change any of these informational messages.

The AMI BIOS setup utility uses a key-based navigation system called "hot keys." Most of the AMI BIOS setup utility "hot keys" can be used at any time during setup navigation. These keys include <F3>, <F4>, <Enter>, <ESC>, arrow keys, etc.

 **Note 1:** Options printed in **Bold** are default settings.

**Note 2:** <F3> is used to load optimal default settings. <F4> is used to save the settings and exit the setup utility.

## How To Change the Configuration Data

The configuration data that determines the system parameters may be changed by entering the AMI BIOS setup utility. This setup utility can be accessed by pressing <Delete> at the appropriate time during system boot.

 **Note:** For AMI UEFI BIOS Recovery, please refer to the UEFI BIOS Recovery User Guide posted @ <http://www.supermicro.com/support/manuals/>.

## Starting the Setup Utility

Normally, the only visible Power-On Self-Test (POST) routine is the memory test. As the memory is being tested, press the <Delete> key to enter the main menu of the AMI BIOS setup utility. From the main menu, you can access the other setup screens. An AMI BIOS identification string is displayed at the left bottom corner of the screen below the copyright message.

**Warning:** Do not upgrade the BIOS unless your system has a BIOS-related issue. Flashing the wrong BIOS can cause irreparable damage to the system. In no event shall the manufacturer be liable for direct, indirect, special, incidental, or consequential damage arising from a BIOS update. If you have to update the BIOS, do not shut down or reset the system while the BIOS is being updated to avoid possible boot failure.

## 4-2 Main Setup

When you first enter the AMI BIOS setup utility, you will enter the Main setup screen. You can always return to the Main setup screen by selecting the Main tab on the top of the screen. The Main BIOS Setup screen is shown below.



The AMI BIOS Main menu displays the following information:

**System Date/System Time**

Use this option to change the system date and time using the arrow keys. Enter new values through the keyboard and press <Enter>. Press the <Tab> key to move between fields. The date must be entered in Day MM/DD/YYYY format. The time is entered in HH:MM:SS format. (**Note:** The time is in the 24-hour format. For example, 5:30 P.M. appears as 17:30:00.).

**Supermicro X10QBL-4CT****BIOS Version**

This item displays the SMC version of the BIOS ROM used in this system.

**Build Date**

This item displays the date that the BIOS setup utility was built.

**CPLD Version**

This item displays the version of 'Complex Programmable Logic Device' (CPLD) used in this system.

**Memory Information****Total Memory**

This item displays the amount of memory that is available in the system.

## 4-3 Advanced Setup Configurations

Select the Advanced tab to access the following submenu items.

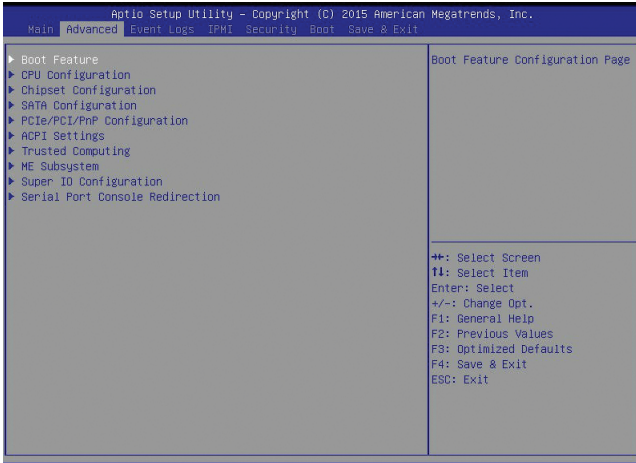

### ► Boot Features

#### Boot Configuration

##### Quiet Boot

Use this item to select bootup screen display between POST messages and the OEM logo. Select Disabled to display the POST messages. Select Enabled to display the OEM logo instead of the normal POST messages. The options are **Enabled** and Disabled.

##### AddOn ROM Display Mode

Use this item to set the display mode for the Option ROM. Select Keep Current to use the current AddOn ROM Display setting. Select Force BIOS to use the Option ROM display set by the system BIOS. The options are **Force BIOS** and Keep Current.

##### Bootup Num-Lock

Use this item to set the power-on state for the Numlock key. The options are Off and **On**.

##### Wait For 'F1' If Error

Select Enabled to force the system to wait until the 'F1' key is pressed when an error occurs. The options are Disabled and **Enabled**.

### **INT19 (Interrupt 19) Trap Response**

Interrupt 19 is the software interrupt that handles the boot disk function. When this item is set to Immediate, the BIOS ROM of the host adaptors will immediately capture Interrupt 19 at bootup and allow the drive that is attached to the host adaptor to function as the bootable disk. If this item is set to Postponed, the BIOS ROM of the host adaptors will only capture Interrupt 19 during bootup from a legacy device. The options are **Immediate** and Postponed.

### **Re-try Boot**

Select Legacy Boot for the BIOS to continuously attempt to boot from the legacy boot drive. Select EFI Boot for the BIOS to continuously attempt to boot from the EFI boot drive. The options are **Disabled**, Legacy Boot, and EFI Boot.

## **Power Configuration**

### **Watch Dog Function**

If enabled, the Watch Dog timer will allow the system to automatically reboot when a non-recoverable error that lasts for more than five minutes occurs. The options are Enabled and **Disabled**.

### **Power Button Function**

If this feature is set to Instant Off, the system will power off immediately as soon as the user presses the power button. If this feature is set to 4 Seconds Override, the system will power off when the user presses the power button for 4 seconds or longer. The options are **Instant Off** and 4 Seconds Override.

### **Restore on AC Power Loss**

Use this item to set the power state after a power outage. Select Stay Off for the system power to remain off after a power outage. Select Power On to turn on the system power after a power outage. Select Last State to allow the system to resume its last power state before a power outage. The options are Power On, Stay Off, and **Last State**.

## ►CPU Configuration

This submenu displays the following CPU information as detected by the BIOS. It also allows the user to configure CPU settings.

### ►Processor 0/Processor 1/Processor 2/Processor 3

This submenu displays the following information of the CPU installed a CPU socket detected by the BIOS.

- Processor Socket
  
- Processor ID
  
- Processor Frequency
  
- Microcode Revision
  
- L1 Cache RAM
  
- L2 Cache RAM
  
- L3 Cache RAM
  
- Processor Socket
  
- Processor ID
  
- Processor Frequency
  
- Microcode Revision
  
- L1 Cache RAM
  
- L2 Cache RAM
  
- L3 Cache RAM
  
- Processor 0 Version
  
- Processor 1 Version
  
- Processor 2 Version
  
- Processor 3 Version

### Clock Spread Spectrum

Select Enable to allow the BIOS to monitor and attempt to reduce the level of Electromagnetic Interference caused by the components whenever needed. The options are **Disable** and Enable.

### Hyper-Threading (All)

Select Enable to support Intel's Hyper-threading Technology to enhance CPU performance. The options are **Enable** and Disable.

### Cores Enabled

This feature allows the user to set the number of CPU cores to enable. Enter "0" to enable all cores. The default setting is **0**.

 **Note:** To set a valid core number for your system, please refer to the help window on the right side of the BIOS screen, which will prompt you for a valid core number and will also provide a warning when an invalid core number is used.

### Performance/Watt

Select Power Optimized to enable Intel® Turbo Boost Technology support when the Power Performance State-P0 has lasted more than two seconds. The options are **Traditional** and Power Optimized.

### Execute Disable Bit (Available if supported by the OS & the CPU)

Select Enable to support Intel® Execute Disable Bit Technology, which will allow the processor to designate areas in the system memory where an application code can be executed and where it cannot, thus preventing a worm or a virus from flooding illegal codes to overwhelm the processor or damage the system during an attack.

The default setting is **Enable**. (Refer to Intel and Microsoft websites for more information.)

### Intel® Virtualization Technology (Available when supported by the CPU)

Select Enabled to support Intel Virtualization Technology, which will allow one platform to run multiple operating systems and applications in independent partitions, creating multiple "virtual" systems in one physical computer. The options are **Enabled** and Disabled.

### Hardware Prefetcher (Available when supported by the CPU)

If set to Enabled, the hardware prefetcher will prefetch streams of data and instructions from the main memory to the L2 cache to improve CPU performance. The options are Disabled and **Enabled**.

### Adjacent Cache Prefetch (Available when supported by the CPU)

Select Enable for the CPU to prefetch both cache lines for 128 bytes as comprised. Select Disable for the CPU to prefetch both cache lines for 64 bytes. The options are Disable and **Enable**.

 **Note:** Please reboot the system for changes on this setting to take effect. Please refer to Intel's web site for detailed information.

### DCU (Data Cache Unit) Streamer Prefetcher (Available when supported by the CPU)

If this item is set to Enable, the DCU Streamer Prefetcher will prefetch data streams from the cache memory to the DCU (Data Cache Unit) to speed up data accessing and processing for CPU performance enhancement. The options are Disable and **Enable**.

### DCU IP Prefetcher

If this feature is set to Enable, the IP prefetcher in the DCU (Data Cache Unit) will prefetch IP addresses to improve network connectivity and system performance. The options are **Enable** and Disable.

### DCU Mode

Use this feature to set the data-prefetching mode for the DCU (Data Cache Unit). The options are **32KB 8Way Without ECC** and 16KB 4Way With ECC.

### Direct Cache Access (DCA)

Select Enable to use Intel DCA (Direct Cache Access) Technology to improve the efficiency of data transferring and accessing. The options are **Enable** and Disable.

### AES-NI (New Encryption Standard-New Instructions)

Select Enable to use the Intel Advanced Encryption Standard (AES) New Instructions (NI) to ensure data security. The options are **Enable** and Disable.

### PPIN

Select Yes to use the Protected-Processor Inventory Number (PPIN) in the system. The options are **No** and Yes.

---

## ► Advanced Power Management Configuration

This section is used to configure the following CPU Power Management settings.

### Power Technology

Select Energy Efficiency to support power-saving mode. Select Custom to customize system power settings. Select Disabled to disable power-saving settings. The options are Disable, **Energy Efficiency**, and Custom.

If the above is set to 'Custom' the following options are displayed:

## ► CPU P State Control (Available when Power Technology is set to Customer)

### EIST

EIST (Enhanced Intel SpeedStep Technology) allows the system to automatically adjust processor voltage and core frequency to reduce power consumption and heat dissipation. The options are Disable, and **Enable**.

### Turbo Mode (Available when Intel® EIST Technology is enabled)

Select Enable to use the Turbo Mode to boost system performance. The options are **Enable** and Disable.

### P-State Coordination

This feature allows the user to change the P-State (Power-Performance State) coordination type. P-State is also known as "SpeedStep" for Intel processors. Select HW\_ALL to change the P-State coordination type for hardware components only. Select SW\_ALL to change the P-State coordination type for all software installed in the system. Select SW\_ANY to change the P-State coordination type for a software program in the system. The options are **HW\_All**, SW\_ALL, and SW\_ANY.

### SINGLE\_PCTL

Select Yes for SINGLE\_PCTL support to improve processor power management. The options are **No** and Yes.

### Config TDP

Select Enable to allow the user to configure the Thermal Design Power (TDP) settings for the system. The TDP refers to the maximum amount of power allowed for running "real applications" without triggering an overheating event. The options are **Disable** and Enable.

## ► CPU C State Control (Available when Power Technology is set to Customer)

### C2C3TT

This feature allows the user to set the C2 to C3 Transition timer. The default setting is **0 (for Auto setting)**.

### Package C-State limit

This feature allows the user to set the limit on the C-State package register. The options are C0/C1 State, C2 State, C6 (Non Retention) State, and **C6 (Retention) State**.

### CPU C3 Report

Select Enabled to allow the BIOS to report the CPU C3 State (ACPI C2) to the operating system. During the CPU C3 State, the CPU clock generator is turned off. The options are Enable and **Disable**.

### CPU C6 Report

Select Enabled to allow the BIOS to report the CPU C6 State (ACPI C3) to the operating system. During the CPU C6 State, the power to all cache is turned off. The options are **Enable** and Disable.

### Enhanced Halt State (C1E)

Select Enabled to use Enhanced Halt-State technology, which will significantly reduce the CPU's power consumption by reducing the CPU's clock cycle and voltage during a Halt-state. The options are Disable and **Enable**.

### Monitor/Mwait

Select Enabled to enable the Monitor/MWait instructions. The Monitor instruction monitors a region of memory for writes, and MWait instructions instruct the CPU to stop until the monitored region begins to write. The options are **Enable** and Disable.

## ► CPU T State Control (Available when Power Technology is set to Customer)

### ACPI (Advanced Configuration Power Interface) T-States

Select Enable to support CPU throttling by the operating system to reduce power consumption. The options are **Enable** and Disable.

---

## ▶ CPU Advanced PM Turning (Available when Power Technology is set to Customer)

### ▶ Energy Perf BIAS

#### Energy Perf BIAS

##### Energy Performance Tuning

Use this feature to select whether the BIOS or operating system chooses energy performance BIAS Tuning. The options are OS and **BIOS**.

##### Energy Performance BIAS Setting.

Use this item to set the energy performance bias, which overrides the operating system setting. The options are Performance, **Balanced Performance**, Balanced Power, and Power.

##### Workload Configuration

Use this item to optimize the workload characterization. The recommended setting is Balanced. The options are **Balanced** and I/O sensitive.

## ▶ Chipset Configuration

### ▶ North Bridge

This feature is used to configure Intel North Bridge settings.

### ▶ Integrated IO Configuration

#### EV DFX (Device Function On-Hide) Features

When this feature is set to Enable, the EV\_DFX Lock Bits that are located inside a processor will always remain clear during electric tuning. The options are **Disable** and Enable.

### ▶ IIO0 Configuration

#### ▶ CPU1 SLOT1 PCI-E 3.0 X16

Use the items below to configure the PCI-E settings for a PCI-E port specified by the user.

The following items will display:

- PCI-E Port Link Status

- PCI-E Port Link Max
- PCI-E Port Link Speed

### **Link Speed**

Use this item to select the PCI-E link speed for the PCI-E port specified by the user. The options are Auto, GEN1 (2.5 GT/s), **GEN2 (5 GT/s)**, and GEN3 (8 GT/s).

### **PCI-E ASPM Support**

Select Enable to support the Active State Power Management (ASPM) level for a PCI-E port specified by the user. Select Disabled to disable ASPM support. The options are Auto, Disable, and **L1 Only**.

## **►LAN1/2**

Use the items below to configure the PCI-E settings for a PCI-E device installed on a LAN connection specified by the user.

The following items will display:

- PCI-E Port Link Status
- PCI-E Port Link Max
- PCI-E Port Link Speed

### **Link Speed**

Use this item to select the PCI-E link speed for the PCI-E port specified by the user. The options are GEN1 (2.5 GT/s), GEN2 (5 GT/s), GEN3 (8 GT/s), and **Auto**.

### **PCI-E ASPM Support**

Select Enable to support the Active State Power Management (ASPM) level for a PCI-E port specified by the user. Select Disabled to disable ASPM support. The options are Auto, Disable, and **L1 Only**.

## **►L-SAS0-3(JSAS1)/L-SAS4-7(JASA2)**

Use the items below to configure the PCI-E settings for a PCI-E device installed on a SAS connection specified by the user.

The following items will display:

- PCI-E Port Link Status
- PCI-E Port Link Max
- PCI-E Port Link Speed

### **Link Speed**

Use this item to select the PCI-E link speed for the PCI-E port specified by the user. The options are GEN1 (2.5 GT/s), GEN2 (5 GT/s), GEN3 (8 GT/s), and **Auto**.

## **► I/O1 Configuration**

### **No PCIe Port Active ECO**

Use this feature to select a workaround setting to implement the engineering-change order (ECO) on the system when PCI ports are not active. The options are PCU Squelch exit ignore option, and **Reset the SQ FLOP by CSR option**.

## **► CPU2 SLOT3 PCI-E 3.0 X16/CPU2 SLOT2 PCI-E 3.0 X8/ CPU2 SLOT4 PCI-E 3.0 X8**

Use the items below to configure the PCI-E settings for a PCI-E port specified by the user.

The following items will display:

- PCI-E Port Link Status
- PCI-E Port Link Max
- PCI-E Port Link Speed

### **Link Speed**

Use this item to select the PCI-E link speed for the PCI-E port specified by the user. The options are **Auto**, GEN1 (2.5 GT/s), **GEN2 (5 GT/s)**, and GEN3 (8 GT/s).

## ► IOAT (Intel® IO Acceleration) Configuration

### Enable IOAT

Select Enable to enable Intel I/OAT (I/O Acceleration Technology) support, which will significantly reduce CPU overhead by leveraging CPU architectural improvements and freeing the system resource for other tasks. The options are **Enable** and Disable.

### No Snoop

Select Enable to support no-snoop mode for each CB device. The options are **Disable** and Enable.

### Disable TPH (TLP Processing Hint).

If this item is set to Enable, TLP Processing Hint will be disabled. The options are Disable and **Enable**.

## ► Intel VT for Directed I/O (VT-d)

### Intel VT for Direct I/O (VT-d)

Select Enable to use Intel Virtualization Technology support for Direct I/O VT-d support by reporting the I/O device assignments to the VMM (Virtual Machine Monitor) through the DMAR ACPI Tables. This feature offers fully-protected I/O resource sharing across Intel platforms, providing greater reliability, security and availability in networking and data-sharing. The options are **Enable** and Disable.

### Interrupt Remapping

Select Enable to support Interrupt Remapping to enhance system performance. The options are **Enable** and Disable.

## PCI Express Global Options

### Power Down Unused Ports

Select Enable to disable the PCI-E ports that are inactive. The options are **Disable**, Enable, HSX Disable Unused Ports (No IIO Clock Gating), and HSX Disable Unused Ports (IIO Clock Gating)

## ► QPI (Quick Path Interconnect) Configuration

### ► QPI General Configuration

#### ► QPI Status

The following information will display:

- Number of CPU
- Number of IIO
- Link Speed
- Current QPI Link Frequency
- QPI Global MMIO Low Base/Limit
- QPI Global MMIO High Base/Limit
- QPI Pci-e Configuration Base/Siz (Size)

#### Link Speed Mode

Use this feature to select the data transfer speed for QPI Link connections. The default setting is **Fast**.

#### Link Frequency Select

Use this feature to select the desired frequency for QPI Link connections. The options are 6.4GB/s, 7.2GB/s, 8.0GB/s, 9.6GB/s, **Auto**, Auto Limited, and Use Per Link Setting.

#### Link L0p Enable

Select Enable for Link L0p support. The options are **Enable** and Disable.

#### Link L1 Enable

Select Enable for Link L1 support. The options are **Enable** and Disable.

#### Legacy VGA Socket

Enter the VGA socket number (from 0-7) that will be used to support legacy VGA. The default setting is **0**.

## ► QPI Per Socket Configuration

### ► CPU 1/CPU 2

#### IO Resource Allocation Ratio

Use this feature to set the IO resource-allocation ratio (from 0-8). The default setting is **3**.

#### MMIOL Resource Allocation Ratio

Use this feature to set the Memory-Mapped IO resource-allocation ratio (from 0-8). The CPU1 default setting is **3**, and for CPU2 is **1**.

#### IIO UniPhy Disable

Select Yes to hide the entire UNIFY in the L2 cache. The options are **No**, Yes, and Yes w/Memory Hot Add.

## ► Memory Configuration

This section displays the following Integrated Memory Controller (IMC) information.

#### DDR Speed

Use this feature to force a DDR4 memory module to run at a frequency other than what is specified in the specification. The options are **Auto**, 1067, 1333, 1600, 1867, and 2133.

#### ODT (On-Die Termination) Timing Mode

Use this feature to configure the timing mode setting for the ODT (On-Die Termination) where the termination resistor for impedance matching in transmission lines is located inside a chip instead of on a printed circuit board. The options are **Aggressive Timing** and Conservative Timing.

#### MaxB Rank Sharing Mapping

Use this feature to select the address-mapping setting for memory-rank sharing to enhance extended multimedia platform performance. The options are **Maximum Performance** and Maximum Margin.

#### LRDIMM (Load-Reduction DIMM) Module Delay

When this item is set to Disabled, the MRC (Memory Regulator Controller) will not use SPD bytes 90-95 for module delay on LRDIMM memory. The options are **Disabled** and Auto.

**Data Scrambling**

Select Enabled to enable data scrambling to enhance system performance and data integrity. The options are Disabled and **Enabled**.

**VMSE Lockstep Mode**

Select Enabled to support the VMSE Lockstep mode, which will support Lock step mode for the Intel Scalable Memory Interconnect 2 (Intel SMI 2) controller. The options are 1 vs 1, and **Mode 2 vs 1 Mode**.

**HA (Hash Mode) Early Write Post Mode**

Select Enable to support memory hash-method-comparison mode when the system is running at the early stage of POST (Power-On-Self-Test). The options are **Enable** and Disabled.

**Command 2 Data Tuning**

Select Enabled to fine-tune electrical command paths from the host system to the memory-extension buffer (MXB). The options are **Enabled** and Disabled.

**Closed Loop Thermal Throttling**

Select Enabled to support Closed-Loop Thermal Throttling which will improve reliability and reduces CPU power consumption via automatic voltage control while the CPU are in idle states. The options are Disabled and **Enabled**.

**Normal Operation Duration**

Use this feature to select the normal operation duration interval. The default value is 1024.

**VMSE Clock Stop**

Select Enabled to de-activate the clock driver for the Intel Scalable Memory Interconnect 2 (Intel SMI 2) controller. The options are **Enabled** and Disabled.

**►Memory Topology**

This item displays the status of each DIMM module as detected by the BIOS.

- Jordon Creek Revision ID
  
- Node
  
- Channel
  
- DIMM Frequency

## ► **Memory RAS (Reliability\_Availability\_Serviceability) Configuration (Available when a DIMM module is detected in a memory slot specified)**

Use this submenu to configure the following Memory RAS settings.

### **Memory RAS Configuration Setup**

#### **Current Memory Mode**

This item displays the current memory mode. The default setting is **Independent**.

#### **Mirroring**

This item indicates if memory mirroring is supported by the motherboard. Memory mirroring creates a duplicate copy of the data stored in the memory to enhance data security. This feature is currently not available for this motherboard.

#### **Sparing**

This item indicates if memory sparing is supported by the motherboard. Memory sparing enhances system performance.

#### **Memory Rank Sparing**

This item indicates if memory rank sparing is supported by the motherboard. Memory rank sparing enhances system memory performance. The options are **Enabled** and **Disabled**.

#### **Spare Error/Memory Correctable Thr (Threshold)**

Use this feature to set the correctable error threshold for spare memory modules. The default setting is **10**.

#### **Leaky Bucket Low Bit**

Use this feature to set the Low Bit value for the Leaky Bucket algorithm which is used to check the data transmissions between CPU sockets and the memory controller. The default setting is **40**.

#### **Leaky Bucket High Bit**

Use this feature to set the High Bit value for the Leaky Bucket algorithm which is used to check the data transmissions between CPU sockets and the memory controller. The default setting is **41**.

#### **CPU1 MC1 Spare/CPU2 MC1 Spare/CPU3 MC1 Spare/CPU4 MC1 Spare (Available when Memory Rank Sparing is set to Enabled)**

Select **Enabled** to enable memory sparing support for a memory module installed on a memory channel specified by a user for memory performance enhancement. The options are **Enabled** and **Disabled**.

### Memory Interleaving

Use this feature to set the DIMM memory interleaving mood. The options are NUMA (1-way) Node Interleave, **2-way Node Interleave**, 4-way Interleave, 8 Way Interleaving, Inter-socket, and Auto.

### Socket Interleave Below 4GB

Select Enabled for the memory above the 4G Address space to be split between two sockets. The options are Enable and **Disable**.

### Channel Interleaving

Use this feature to set the DIMM channel interleaving mood. The options are **Auto**, 1-Way Interleave, 2-Way Interleave, 3-Way Interleave, and 4-Way Interleave.

### Rank Interleaving

Use this feature to select a rank memory interleaving method. The options are **Auto**, 1-Way Interleave, 2-Way Interleave, 3-Way Interleave, 4-Way Interleave, and 8-Way Interleave.

### Patrol Scrub (Available when it is supported by the hardware components)

Patrol Scrubbing is a process that allows the CPU to correct correctable memory errors detected on a memory module and send the correction to the requestor (the original source). When this item is set to Enable, read-and-write will be performed every 16K cycles per cache line if there is no delay caused by internal processing. The options are **Enable** and Disable.

### Demand Scrub

Demand Scrubbing is a process that allows the CPU to correct correctable memory errors found on a memory module. When the CPU or I/O issues a demand-read command, and the read data from memory turns out to be a correctable error, the error is corrected and sent to the requestor (the original source). Memory is updated as well. Select Enable to use Demand Scrubbing for ECC memory correction. The options are **Enable** and Disable.

### Device Tagging

Select Enable to support device tagging. The options are **Disable**, Rank SDDC, and Bank SDDC.

### A7 Mode

Select Enabled to support A7 (Addressing) Mode to improve memory performance. The options are **Disable** and Enable.

### **DDDC Support**

Select Enabled to enable Double-Device Data Correction (DDDC) support for the error-correction codes to correct memory errors caused by two failed DRAM devices. The options are **Disabled**, Rank DDDC, and Bank DDDC.

### **DDDC Wirekill (Available when DDDC support is set to Rank DDDC)**

Select Enabled for Double-Device Data Correction (DDDC) Wire-kill support which will disable the wire connection between two DRAM devices when they fail. The options are **Disabled** and Enabled.

### **DDDC Wirekill (Wire-Kill) Threshold (Available when DDDC support is set to Rank DDDC, and DDDC Wirekill is set to Enabled)**

Use this feature to set the DDDC Wirekill threshold. When the memory errors reach the threshold, wire-connections between the failed DRAM modules will be disconnected. The Default setting is **2**.

### **Memory Mirroring**

Select Enable to enable memory-mirroring support which will create a duplicate copy of the data stored in the memory to enhance data security. The options are **Disable** and Full CH Mirroring.

### **Mirror Scrub (Available when Memory Mirroring is set to Enable)**

Select Enable for Mirror Scrubbing support which will allow the CPU to correct correctable memory errors found on a memory module when the memory scheme is set to Memory Mirroring. The options are **Enable** and Disable.

### **CPU1 MC1 Mirror/CPU2 MC1 Mirror/CPU3 MC1 Mirror/CPU4 MC1 Mirror (Unavailable when Memory Mirror is set to Disabled)**

Select Enabled to enable memory sparing support for a memory module installed on a memory channel specified by a user for memory performance enhancement. The options are Enabled and **Disabled**.

## **► South Bridge**

This feature is used to configure Intel South Bridge settings.

## **► USB Configuration**

The following USB items will display.

- USB Module Version
- USB Devices

**Legacy USB Support (Available when USB Functions is not Disabled)**

Select Enabled to support legacy USB devices. Select Auto to disable legacy support if USB devices are not present. Select Disabled to have USB devices available for EFI (Extensive Firmware Interface) applications only. The settings are Disabled, **Enabled** and Auto.

**USB 2.0 Controller Mode**

Select HiSpeed for the USB 2.0 controller to operate at the HiSpeed mode (480Mb per second). Select FullSpeed for the USB 2.0 controller to operate at the Full Speed mode (12Mb per second). The options are Full Speed, and **HiSpeed**.

**EHCI Hand-Off**

This item is for operating systems that do not support Enhanced Host Controller Interface (EHCI) hand-off. When this item is enabled, EHCI ownership change will be claimed by the EHCI driver. The settings are Enabled and **Disabled**.

**Port 60/64 Emulation**

Select Enabled for I/O port 60h/64h emulation support which will provide complete USB keyboard legacy support for the operating system that does not support Legacy USB devices. The options are Disabled and **Enabled**.

**USB Controller 0 Enable**

Select Enabled to enable USB Controller 0 which supports USB Port 0 to Port 7. The options are Disabled and **Enabled**.

**USB Controller 1 Enable**

Select Enabled to enable USB Controller 1 which supports USB Port 8 to Port 13. The options are Disabled and **Enabled**.

**►SATA Configuration**

When this submenu is selected, the AMI BIOS automatically detects the presence of the SATA devices that are supported by the Intel PCH chip and displays the following items:

**SATA Controller**

This item enables or disables the onboard SATA controller supported by the Intel PCH chip. The options are **Enabled** and Disabled.

**Configure SATA as**

Select IDE to configure a SATA drive specified by the user as an IDE drive. Select AHCI to configure a SATA drive specified by the user as an AHCI drive. Select

RAID to configure a SATA drive specified by the user as a RAID drive. The options are IDE, **AHCI**, and RAID.

***\*If the item above "Configure SATA as" is set to AHCI, the following items will display:***

**SATA Port 0~ Port 5**

This item displays the information detected on the installed SATA drive on the particular SATA port.

- Display of drive number and capacity as detected by the BIOS

**Port 0~ Port 5**

Select Enabled to enable a SATA port specified by the user. The options are Disabled and Enabled.

**Port 0 ~ Port 5 Hot Plug**

This feature designates the port specified for hot plugging. Set this item to Enabled for hot-plugging support, which will allow the user to replace a SATA disk drive without shutting down the system. The options are **Enabled** and Disabled.

**Port 0 ~ Port 5 Spin Up Device**

On an edge detect from 0 to 1, set this item to allow the PCH to initialize the device. The options are Enabled and **Disabled**.

***\*If the item above "Configure SATA as" is set to IDE, the following items will display:***

**Serial ATA Port 0~ Port 5**

This item indicates that a SATA port specified by the user is not installed or not present.

- Display of drive number and capacity as detected by the BIOS

***\*If the item above "Configure SATA as" is set to RAID, the following items will display:***

**SATA RAID Option ROM Type**

Use this item to select the device type for onboard SATA RAID Option ROM for system boot. The options are EFI and **Legacy**.

**Serial ATA Port 0~ Port 5**

This item displays the information detected on the installed SATA drives on the particular SATA port.

- Display of drive number and capacity as detected by the BIO

**Port 0~ Port 5**

Select Enabled to enable a SATA port specified by the user. The options are Disabled and Enabled.

**Hot Plug**

This feature designates this port for hot plugging. Set this item to Enabled for hot-plugging support, which will allow the user to replace a SATA drive without shutting down the system. The options are Enabled and **Disabled**.

**Spin Up Device**

On an edge detect from 0 to 1, set this item to allow the PCH to start a COMRESET initialization to the device. The options are Enabled and **Disabled**.

**► PCIe/PCI/PnP Configuration****PERR# Generation**

Select Enabled to allow a PCI/PCI-E device to generate a PCI/PCI-E Parity-Error (PERR) number for a PCI Bus Signal Error Event. The options are Enabled and **Disabled**.

**SERR# Generation**

Select Enabled to allow a PCI/PCI-E device to generate a System-Error (SERR) number for a PCI Bus Signal Error Event. The options are Enabled and **Disabled**.

**PCI AER (Advanced Error-Reporting) Support**

Select Enabled to support Advanced Error-Reporting for onboard PCI devices. The options are **Disabled** and Enabled.

**Above 4G Decoding (Available if the system supports 64-bit PCI decoding)**

Select Enabled to decode a PCI device that supports 64-bit in the space above 4G Address. The options are Enabled and **Disabled**.

**SR-IOV Support (Available if the system supports Single-Root Virtualization)**

Select Enabled for Single-Root IO Virtualization support. The options are **Enabled** and Disabled.

**Maximum Payload**

Select Auto to allow the system BIOS to automatically set the maximum payload value for a PCI-E device to enhance system performance. The options are **Auto**, 128 Bytes, 256 Bytes, 512 Bytes, 1024 Bytes, 2048 Bytes, and 4096 Bytes.

### Maximum Read Request

Select Auto to allow the system BIOS to automatically set the maximum Read Request size for a PCI-E device to enhance system performance. The options are **Auto**, 128 Bytes, 256 Bytes, 512 Bytes, 1024 Bytes, 2048 Bytes, and 4096 Bytes.

### ASPM Support

This feature allows the user to set the Active State Power Management (ASPM) level for a PCI-E device. Select Force L0s to force all PCI-E links to operate at L0s state. Select Auto to allow the system BIOS to automatically set the ASPM level for the system. Select Disabled to disable ASPM support. The options are **Disabled**, Force L0s, and Auto.

### PCI-E ASPM (Global)

Select Per-Port to support the Active State Power Management (ASPM) level for all PCI-E ports on the motherboard. Select L1 to force all PCI-E links to operate at L1 state. The options are **L1 Only**, and Per-Port

### MMIOH Size PerIIO

Use this item to set the MMIO (Memory-Mapped I/O Hub) size for each IIO device. The options are 0x8\_00000000 (32GB), 0x10\_00000000 (64GB), **0x20\_00000000 (128GB)**, 0x40\_00000000 (256GB), 0x80\_00000000 (512GB), and 0x100\_00000000 (1024GB).

### MMIOHBase

Use this item to select the base memory size according to memory-address mapping for the IO hub. The base memory size must be between 4032G to 4078G. The options are **0x3800\_00000000 (56T)**, 0x2800\_00000000 (40T), and 0x1800\_00000000 (24T).

### Resource Auto Adjust

Select Enable for the PCI resource-requests for each CPU socket to be automatically adjusted on a need basis when the PCI resource allocator fails. The options are **Enable** and Disable.

**Warning:** Enabling ASPM support may cause some PCI-E devices to fail!

### PCI Devices Option ROM Setting

**CPU1 SLOT1 PCI-E 3.0 x16 OPROM/CPU1 SLOT2 PCI-E 3.0 x8 OPROM/  
CPU2 SLOT3 PCI-E 3.0 x16 OPROM/CPU2 SLOT4 PCI-E 3.0 x8 OPROM/**

Use this feature to select the type of device installed on a slot specified by the user for the system to boot from. The options are EFI, **Legacy** and Disabled.

### Video

This feature controls how the system executes UEFI (Unified Extensible Firmware Interface), and legacy Option ROM. Select Legacy Only to boot the system using a legacy video device. The options are Do not launch, UEFI Only and **Legacy Only**.

### VGA Priority

This feature allows the user to select the graphics adapter to be used as the primary boot device. The options are **Onboard** and Offboard.

### Onboard LAN Option ROM Type

Use this item to select the device type for onboard LAN Option ROM for system boot. The options are EFI and **Legacy**.

### Onboard LAN 1 OPROM/Onboard LAN 2 OPROM

Select iSCSI to use the iSCSI Option ROM to boot the computer using a iSCSI network device. Select PXE (Preboot Execution Environment) to use an PXE Option ROM to boot the computer using a PXE network device. The default option for Onboard LAN 1 is **PXE and for Onboard LAN 2 is Disabled**.

## ▶ACPI Settings

### High Precision Event Timer

Select Enabled to activate the High Precision Event Timer (HPET) that produces periodic interrupts at a much higher frequency than a Real-time Clock (RTC) does in synchronizing multimedia streams, providing smooth playback, reducing the dependency on other timestamp calculation devices, such as an x86 RDTSC Instruction embedded in the CPU. The High Performance Event Timer is used to replace the 8254 Programmable Interval Timer. The options are **Enabled** and Disabled.

### WHEA Support

Select Enabled to support the Windows Hardware Error Architecture (WHEA) platform and provide a common infrastructure for the system to handle hardware errors within the Windows OS environment to reduce system crashes and to enhance system recovery and health monitoring. The options are **Enabled** and Disabled.

## ► Trusted Computing (Available when a TPM device is detected by the BIOS)

### Configuration

#### Security Device Support

Select Enabled on this item and enable the TPM jumper on the motherboard to enable onboard security devices to improve data integrity and network security. The options are **Enabled** and Disabled.

#### TPM (Trusted-Platform Module) State

Select Enabled to enable TPM security settings to improve data integrity and network security. The options are Disabled and **Enabled**.

### Pending Operation

Use this item to schedule an operation for the security device. The options are **None**, Enable Take Ownership, Disable Take Ownership, and TPM Clear.

 **Note:** The computer will reboot in order to execute the pending commands and change the state of the security device.

**Current Status Information:** This item displays the information regarding the current TPM status.

#### TPM Enable Status

This item displays the status of TPM Support to indicate if TPM is currently enabled or disabled.

#### TPM Active Status

This item displays the status of TPM Support to indicate if TPM is currently active or deactivated.

#### TPM Owner Status

This item displays the status of TPM Ownership.

### TXT Support

Select Enabled for Trusted Execution Technology support. The options are Enabled and **Disabled**.

## ► ME (Management Engine) Subsystem

This feature displays the following ME Subsystem Configuration settings.

General ME Configuration

Operational Firmware Version

Recovery Firmware Version  
ME Firmware Features  
ME Firmware Status #1  
ME Firmware Status #2  
Current State  
Error Code

## ► Super IO Configuration

**Super IO Chip:** This item displays the Super IO chip used in the motherboard.

## ► Serial Port 1 Configuration

### Serial Port

Select Enabled to enable a serial port specified by the user. The options are **Enabled** and Disabled.

### Device Settings

This item displays the settings of Serial Port 1 (COM).

### Change Port 1 Settings

This option specifies the base I/O port address and the Interrupt Request address of Serial Port 1 (COM). Select Disabled to prevent the serial port from accessing any system resources. When this option is set to Disabled, the serial port becomes unavailable. The options are **Auto**, IO=3F8h; IRQ=4; IO=3F8h; IRQ=3, 4, 5, 6, 7, 9, 10, 11, 12; IO=2F8h; IRQ=3, 4, 5, 6, 7, 9, 10, 11, 12; IO=3E8h; IRQ=3, 4, 5, 6, 7, 9, 10, 11, 12; IO=2E8h; IRQ=IRQ=3, 4, 5, 6, 7, 9, 10, 11, 12.

## ► Serial Port 2 Configuration

### Serial Port

Select Enabled to enable a serial port specified by the user. The options are **Enabled** and Disabled.

### Change Port 2 Settings

This option specifies the base I/O port address and the Interrupt Request address of Serial Port 2 (SOL). Select Disabled to prevent the serial port from accessing any system resources. When this option is set to Disabled, the serial port becomes unavailable. The options are **Auto**, O=2F8h; IRQ=4; IO=3F8h; IRQ=3, 4, 5, 6, 7, 9, 10, 11, 12; IO=2F8h; IRQ=3, 4, 5, 6, 7, 9, 10, 11, 12; IO=3E8h; IRQ=3, 4, 5, 6, 7, 9, 10, 11, 12; IO=2E8h; IRQ=IRQ=3, 4, 5, 6, 7, 9, 10, 11, 12.

### Serial Port 2 Attribute

Use this feature to select the attribute for this serial port. The options are **SOL** (Serial Over LAN), and **COM**.

## ► Serial Port Console Redirection

### COM 1

#### COM 1 Console Redirection

Select Enabled to enable COM Port 1 Console Redirection, which will allow a client machine to be connected to a host machine at a remote site for networking. The options are **Disabled** and **Enabled**.

*\*If the item above set to Enabled, the following items will become available for configuration:*

## ► COM1 Console Redirection Settings

### Terminal Type

This feature allows the user to select the target terminal emulation type for Console Redirection. Select VT100 to use the ASCII Character set. Select VT100+ to add color and function key support. Select ANSI to use the Extended ASCII Character Set. Select VT-UTF8 to use UTF8 encoding to map Unicode characters into one or more bytes. The options are ANSI, VT100, **VT100+**, and VT-UTF8.

### Bits Per second

Use this item to set the transmission speed for a serial port used in Console Redirection. Make sure that the same speed is used in the host computer and the client computer. A lower transmission speed may be required for long and busy lines. The options are 9600, 19200, 38400, 57600 and **115200** (bits per second).

### Data Bits

Use this feature to set the data transmission size for Console Redirection. The options are 7 (Bits) and **8 (Bits)**.

### Parity

A parity bit can be sent along with regular data bits to detect data transmission errors. Select Even if the parity bit is set to 0, and the number of 1's in data bits is even. Select Odd if the parity bit is set to 0, and the number of 1's in data bits is odd. Select None if you do not want to send a parity bit with your data bits in transmission. Select Mark to add a mark as a parity bit to be sent along with the data bits. Select Space to add a Space as a parity bit to be sent with your data bits. The options are **None**, Even, Odd, Mark and Space.

### Stop Bits

A stop bit indicates the end of a serial data packet. Select 1 Stop Bit for standard serial data communication. Select 2 Stop Bits if slower devices are used. The options are **1** and **2**.

### Flow Control

Use this item to set the flow control for Console Redirection to prevent data loss caused by buffer overflow. Send a "Stop" signal to stop sending data when the receiving buffer is full. Send a "Start" signal to start sending data when the receiving buffer is empty. The options are **None** and Hardware RTS/CTS.

### VT-UTF8 Combo Key Support

Select Enabled to enable VT-UTF8 Combination Key support for ANSI/VT100 terminals. The options are **Enabled** and Disabled.

### Recorder Mode

Select Enabled to capture the data displayed on a terminal and send it as text messages to a remote server. The options are **Disabled** and Enabled.

### Resolution 100x31

Select Enabled for extended-terminal resolution support. The options are Disabled and **Enabled**.

### Legacy OS Redirection Resolution

Use this item to select the number of rows and columns used in Console Redirection for legacy OS support. The options are **80x24** and 80x25.

### Putty KeyPad

This feature selects Function Keys and KeyPad settings for Putty, which is a terminal emulator designed for the Windows OS. The options are **VT100**, LINUX, XTERMR6, SCO, ESCN, and VT400.

### Redirection After BIOS POST

Use this feature to enable or disable legacy Console Redirection after BIOS POST. When the option-Bootloader is selected, legacy Console Redirection is disabled before booting the OS. When the option- Always Enable is selected, legacy Console Redirection remains enabled upon OS bootup. The options are **Always Enable** and Bootloader.

## SOL/COM2

### Console Redirection

Select Enabled to use the SOL port for Console Redirection. The options are **Enabled** and Disabled.

*\*If the item above set to Enabled, the following items will become available for user's configuration:*

## ► SOL/COM2 Console Redirection Settings

Use this feature to specify how the host computer will exchange data with the client computer, which is the remote computer used by the user.

### Terminal Type

Use this feature to select the target terminal emulation type for Console Redirection. Select VT100 to use the ASCII Character set. Select VT100+ to add color and function key support. Select ANSI to use the Extended ASCII Character Set. Select VT-UTF8 to use UTF8 encoding to map Unicode characters into one or more bytes. The options are ANSI, VT100, **VT100+**, and VT-UTF8.

### Bits Per second

Use this feature to set the transmission speed for a serial port used in Console Redirection. Make sure that the same speed is used in the host computer and the client computer. A lower transmission speed may be required for long and busy lines. The options are 9600, 19200, 38400, 57600 and **115200** (bits per second).

### Data Bits

Use this feature to set the data transmission size for Console Redirection. The options are 7 (Bits) and **8 (Bits)**.

### Parity

A parity bit can be sent along with regular data bits to detect data transmission errors. Select Even if the parity bit is set to 0, and the number of 1's in data bits is even. Select Odd if the parity bit is set to 0, and the number of 1's in data bits is odd. Select None if you do not want to send a parity bit with your data bits in transmission. Select Mark to add a mark as a parity bit to be sent along with the data bits. Select Space to add a Space as a parity bit to be sent with your data bits. The options are **None**, Even, Odd, Mark and Space.

### Stop Bits

A stop bit indicates the end of a serial data packet. Select 1 Stop Bit for standard serial data communication. Select 2 Stop Bits if slower devices are used. The options are **1** and 2.

### Flow Control

Use this feature to set the flow control for Console Redirection to prevent data loss caused by buffer overflow. Send a "Stop" signal to stop sending data when the receiving buffer is full. Send a "Start" signal to start data-sending when the receiving buffer is empty. The options are **None** and Hardware RTS/CTS.

### VT-UTF8 Combo Key Support

Select Enabled to enable VT-UTF8 Combination Key support for ANSI/VT100 terminals. The options are **Enabled** and Disabled.

### Recorder Mode

Select Enabled to capture the data displayed on a terminal and send it as text messages to a remote server. The options are **Disabled** and Enabled.

### Resolution 100x31

Select Enabled for extended-terminal resolution support. The options are Disabled and **Enabled**.

### Legacy OS Redirection Resolution

Use this feature to select the number of rows and columns used in Console Redirection for legacy OS support. The options are **80x24** and 80x25.

### Putty KeyPad

This feature selects Function Keys and KeyPad settings for Putty, which is a terminal emulator designed for the Windows OS. The options are **VT100**, LINUX, XTERMR6, SCO, ESCN, and VT400.

### Redirection After BIOS POST

Use this feature to enable or disable legacy Console Redirection after BIOS POST (Power-On Self-Test). When this feature is set to Bootloader, legacy Console Redirection is disabled before booting the OS. When this feature is set to Always Enable, legacy Console Redirection remains enabled upon OS boot. The options are **Always Enable** and Bootloader.

## ► EMS Console Redirection Settings

### Out-of-Band Management Port

The feature selects a serial port in a client server to be used by the Windows Emergency Management Services (EMS) to communicate with a remote host server. The options are **COM1 (Console Redirection)** and COM2/SOL (Console Redirection).

### Terminal Type

Use this feature to select the target terminal emulation type for Console Redirection. Select VT100 to use the ASCII character set. Select VT100+ to add color and function key support. Select ANSI to use the extended ASCII character set. Select VT-UTF8 to use UTF8 encoding to map Unicode characters into one or more bytes. The options are ANSI, VT100, VT100+, and **VT-UTF8**.

### Bits Per Second

This item sets the transmission speed for a serial port used in Console Redirection. Make sure that the same speed is used in both host computer and the client computer. A lower transmission speed may be required for long and busy lines. The options are 9600, 19200, 57600, and **115200** (bits per second).

### Flow Control

Use this item to set the flow control for Console Redirection to prevent data loss caused by buffer overflow. Send a "Stop" signal to stop data-sending when the receiving buffer is full. Send a "Start" signal to start data-sending when the receiving buffer is empty. The options are **None**, Hardware RTS/CTS, and Software Xon/Xoff.

The setting for each these features is displayed:

### Data Bits, Parity, Stop Bits

## 4-4 Event Logs

Select the Event Logs tab to access the following submenu items.

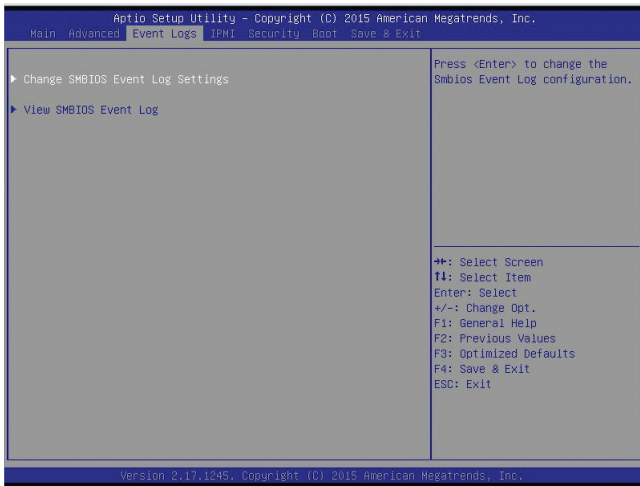

### ► Change SMBIOS Event Log Settings

This feature allows the user to configure SMBIOS Event settings.

#### Runtime Error Logging Support

Select Enabled to enable runtime error logging upon system boot. The options are Auto, Enabled, and **Disabled**.

#### PCI-Ex Error Enable (Available 2hen the item above-Runtime Error Logging Support is set to Enabled)

Select Enabled for the BIOS to correct errors occurred in the PCI-E slots. The options are Enabled and **Disabled**.

#### Enabling/Disabling Options

##### SMBIOS Event Log

Select Enabled to enable SMBIOS (System Management BIOS) event logging during system boot. The options are **Enabled** and Disabled.

#### Erasing Settings

##### Erase Event Log

Select Enabled to erase the SMBIOS (System Management BIOS) event log, which is completed before a event logging is initialized upon system reboot. The options are **No**, Yes, Next reset, and Yes, Every reset.

### **When Log is Full**

Select Erase Immediately to immediately erase SMBIOS error event logs that exceed the limit when the SMBIOS event log is full. Select Do Nothing for the system to do nothing when the SMBIOS event log is full. The options are **Do Nothing** and Erase Immediately.

### **SMBIOS Event Log Standard Settings**

#### **Log System Boot Event**

Select Enabled to log system boot events. The options are **Disabled** and Enabled.

#### **MECI (Multiple Event Count Increment)**

Enter the increment value for the multiple event counter. Enter a number from 1 to 255. The default setting is 1.

#### **METW (Multiple Event Count Time Window)**

This item allows the user to decide how long (in minutes) should the multiple event counter wait before generating a new event log. Enter a number from 0 to 99. The default setting is **60**.

### **►View SMBIOS Event Log**

This item allows the user to view the event in the SMBIOS event log. Select this item and press <Enter> to view the status of an event in the log. The following categories are displayed:

- Date
- Time
- Error Code
- Severity

## 4-5 IPMI

Select the IPMI (Intelligent Platform Management Interface) tab to access the following submenu items.

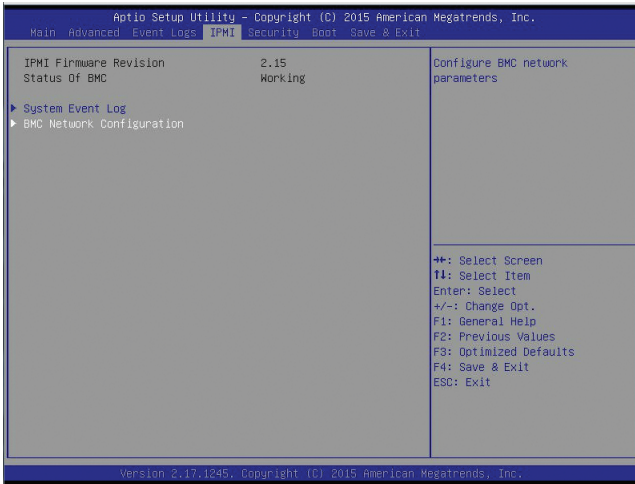

These items indicates your system IPMI firmware revisions, number and status.

- IPMI Firmware Revision
- Status of BMC

### ► System Event Log

#### Enabling/Disabling Options

##### SEL Components

Select Enabled to enable all system event logging support at bootup. The options are **Enabled** and Disabled.

##### Erasing Settings

##### Erase SEL

Select Yes, On next reset to erase all system event logs upon next system reboot.  
 Select Yes, On every reset to erase all system event logs upon each system reboot.  
 Select No to keep all system event logs after each system reboot. The options are **No**, Yes, On next reset, and Yes, On every reset.

### When SEL is Full

This feature allows the user to determine what the BIOS should do when the system event log is full. Select Erase Immediately to erase all events in the log when the system event log is full. The options are **Do Nothing** and Erase Immediately.



**Note:** Reboot the system for the changes to take effect.

## ►BMC Network Configuration

The following items will be displayed:

- IPMI LAN Selection
- IPMI Network Link Status

### Update IPMI LAN Configuration

Select Yes for the system BIOS to automatically reset the following IPMI settings at next system boot. The options are Yes and **No**.

#### **Configuration Address Source (Available when the item above - Update IPMI LAN Configuration is set to Yes)**

Use this item to select the IP address source for this computer. If Static is selected, you will need to know the IP address of this computer and enter it to the system manually in the field. If DHCP is selected, AMI BIOS will search for a DHCP (Dynamic Host Configuration Protocol) server attached to the network and request the next available IP address for this computer. The options are **DHCP** Unspecified, and Static.

#### **Station IP Address**

This item displays the Station IP address for this computer. This should be in decimal and in dotted quad form (i.e., 192.168.10.253).

#### **Subnet Mask**

This item displays the sub-network that this computer belongs to. The value of each three-digit number is separated by dots and it should not exceed 255.

#### **Station MAC Address**

This item displays the Station MAC address for this computer. Mac addresses are 6 two-digit hexadecimal numbers.

#### **Gateway IP Address**

This item displays the Gateway IP address for this computer. This should be in decimal and in dotted quad form (i.e., 10.132.0.250).

## 4-6 Security

This menu allows the user to configure the following security settings for the system.

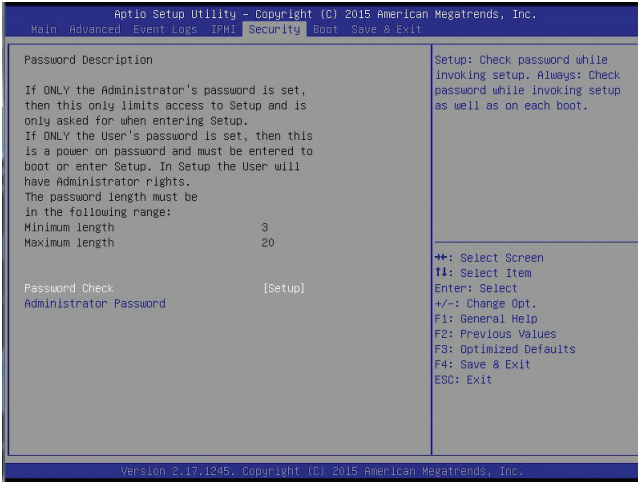

### Password Check

Select Setup for the system to prompt for a password when the user's entering the BIOS setup utility. Select Always for the system to prompt for a password at bootup and when the user's entering the BIOS Setup utility. The options are **Setup** and Always.

### Administrator Password

Use this item to set the administrator password which is required to enter the BIOS setup utility. The length of the password should be from 3 characters to 20 characters long.

### User Password

Use this item to set a user password which is required to log into the system and to enter the BIOS setup utility. The length of the password should be from 3 characters to 20 characters long.

## 4-7 Boot

This submenu allows the user to configure the following boot settings for the system.

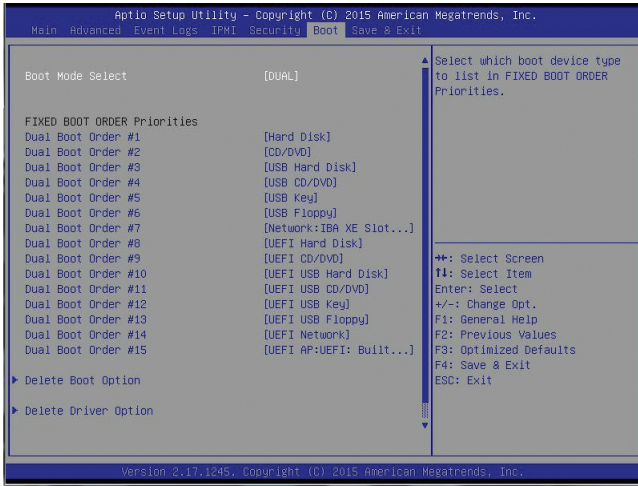

### Boot Mood Select

Use this item to configure boot mood select settings for the machine. The options are Legacy, UEFI, and **Dual**.

### Fixed Boot Order Priorities

This option prioritizes the order of bootable devices that the system to boot from. Press [Enter] on each entry from top to bottom to select devices.

- Boot Order #1 through #15

#### ►Delete Boot Option

Use this item to select a boot device to delete from the boot priority list.

#### Delete Boot Option

Select the target boot device to delete from the boot option list.

#### ►Delete Driver Option

Use this item to select a driver to delete from the boot priority list.

#### Delete Driver Option

Select the target driver to delete.

**► Network Drive BBS Priorities (Available when a device is installed in this drive)**

This item sets the boot sequence of available network boot drives.

- Boot Order #1

**► UEFI Application Boot Priorities (Available when a device is installed in this drive)**

- UEFI Boot Order #1

## 4-8 Save & Exit

This submenu allows the user to configure the Save and Exit settings for the system.

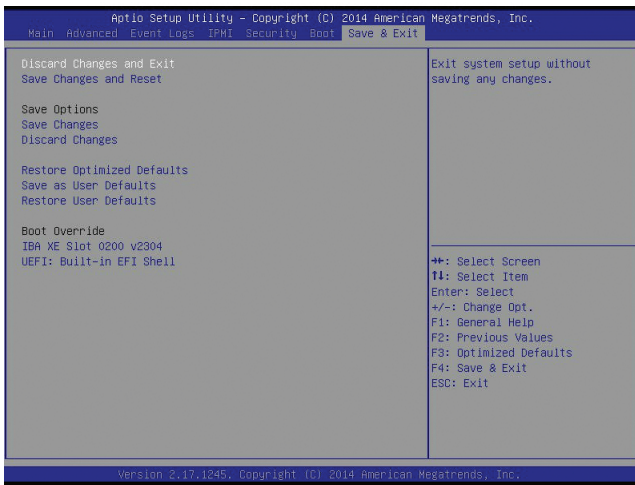

### Discard Changes and Exit

Select this option to quit the BIOS setup without making any changes to the system configuration. Select Discard Changes and Exit, and press <Enter>. When the dialog box appears, asking you if you want to exit the BIOS setup without saving, select **Yes** to quit BIOS without saving the changes.

### Save Changes and Reset

When completing the system configuration changes, select this option to save the changes and reboot the computer so that the new system configuration settings can take effect.

### Save Options

#### Save Changes

Select this option and press <Enter> to save all changes you've made so far and return to the AMI BIOS utility. When the dialog box appears, asking you if you want to save configuration, select **Yes** to save the changes, or select **No** to return to the BIOS without making changes.

#### Discard Changes

Select this feature and press <Enter> to discard all the changes and return to the BIOS setup. When the dialog box appears, asking you if you want to load previ-

ous values, select **Yes** to load the values previous saved, or select No to keep the changes you've made so far.

**Restore Optimized Defaults**

Select this feature and press <Enter> to load the optimized default settings that help optimize system performance. When the dialog box appears, asking you if you want to load the factory defaults, select **Yes** to load the optimized default settings, or select No to abandon optimized defaults.

**Save as User Defaults**

Select this feature and press <Enter> to save the current settings as the user's defaults. When the dialog box appears, asking you if you want to save values as user's defaults, select **Yes** to save the current values as user's default settings, or select No to keep the defaults previously saved as the user's defaults.

**Restore User Defaults**

Select this feature and press <Enter> to load the user's defaults previously saved in the system. When the dialog box appears, asking you if you want to restore user's defaults, select **Yes** to restore the user's defaults previously saved in the system, or select No to abandon the user's defaults that were previously saved.

**Boot Override**

This feature allows the user to override the Boot Option Priority sequence set in the Boot menu, and boot the system with one of the listed devices instead.

## Notes

## Appendix A

### BIOS Error Beep Codes

During the POST (Power-On Self-Test) routines, which are performed at each system boot, errors may occur.

**Non-fatal errors** are those which, in most cases, allow the system to continue to boot. The error messages normally appear on the screen.

**Fatal errors** will not allow the system to continue with bootup procedure. If a fatal error occurs, you should consult with your system manufacturer for possible repairs.

These fatal errors are usually communicated through a series of audible beeps. The numbers on the fatal error list correspond to the number of beeps for the corresponding error.

#### A-1 BIOS Error Beep Codes

Motherboard BIOS Error Beep Codes		
Beep Code/LED	Error Message	Description
1 beep	Refresh	Ready to boot
5 short beeps + 1 long beep	Memory error	No memory detected in the system
5 beeps	No Con-In or No Con-Out devices	Con-In includes USB or PS/2 keyboard, PCI or Serial Console Redirection, IPMI KVM or SOL.  Con-Out includes Video Controller, PCI or Serial Console Redirection, IPMI SOL.
1 beep per device	Refresh	1 beep or each USB device detected
<b>IPMI Error Codes</b>		
1 Continuous Beep	System OH	System Overheat

## Notes

## Appendix B

### Software Installation Instructions

#### B-1 Installing Software Programs

The Supermicro ftp site contains drivers and utilities for your system at <ftp://ftp.supermicro.com>. Some of these must be installed, such as the chipset driver.

After accessing the ftp site, go into the CDR\_Images directory and locate the ISO file for your motherboard. Download this file to create a CD/DVD of the drivers and utilities it contains. (You may also use a utility to extract the ISO file if preferred.)

Another option is to go to the Supermicro Website at <http://www.supermicro.com/products/>. Find the product page for your motherboard here, where you may download individual drivers and utilities.

After creating a CD/DVD with the ISO files, insert the disk into the CD/DVD drive on your system and the display shown below should appear.

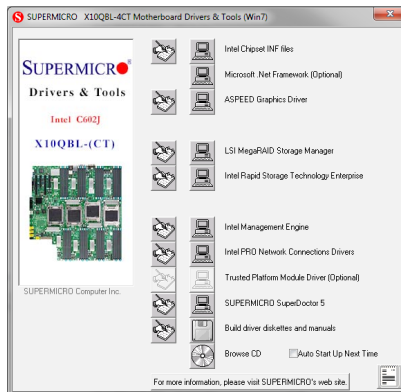

#### Driver/Tool Installation Display Screen



**Note 1:** Click the icons showing a hand writing on paper to view the readme files for each item. Click the computer icons to the right of these items to install each item (from top to the bottom) one at a time. **After installing each item, you must re-boot the system before moving on to the next item on the list.** The bottom icon with a CD on it allows you to view the entire contents.

**Note 2:** When making a storage driver diskette by booting into a Driver CD, please set the SATA Configuration to "Compatible Mode" and configure SATA as IDE in the BIOS Setup. After making the driver diskette, be sure to change the SATA settings back to your original settings.

## B-2 Configuring SuperDoctor 5

The Supermicro SuperDoctor 5 is a hardware monitoring program that functions in a command-line or web-based interface in Windows and Linux operating systems. The program monitors system health information such as CPU temperature, system voltages, system power consumption, fan speed, and provides alerts via email or Simple Network Management Protocol (SNMP).

SuperDoctor 5 comes in local and remote management versions and can be used with Nagios to maximize your system monitoring needs. With SuperDoctor 5 Management Server (SSM Server), you can remotely control power on/off and reset chassis intrusion for multiple systems with SuperDoctor 5 or IPMI. SD5 Management Server monitors HTTP, FTP, and SMTP services to optimize the efficiency of your operation.



**Note:** The default User Name and Password for SuperDoctor 5 is admin/admin.



**Note:** The SuperDoctor 5 program and User's Manual can be downloaded from the Supermicro web site at [http://www.supermicro.com/products/info/sms\\_sd5.cfm](http://www.supermicro.com/products/info/sms_sd5.cfm). For Linux, we recommend that you use the SuperDoctor II application instead.

## Appendix C

### UEFI BIOS Recovery Instructions

**Warning:** Do not upgrade the BIOS unless your system has a BIOS-related issue. Flashing the wrong BIOS can cause irreparable damage to the system. In no event shall Supermicro be liable for direct, indirect, special, incidental, or consequential damages arising from a BIOS update. If you need to update the BIOS, do not shut down or reset the system while the BIOS is updating to avoid possible boot failure.

#### C-1 An Overview to the UEFI BIOS

The Unified Extensible Firmware Interface (UEFI) provides a software-based interface between the operating system and the platform firmware in the pre-boot environment. The UEFI specification supports an architecture-independent mechanism for add-on card initialization to allow the UEFI OS loader, which is stored in the add-on card, to boot the system. The UEFI offers a clean, hands-off control to a computer system at bootup.

#### C-2 How to Recover the UEFI BIOS Image (-the Main BIOS Block)

A UEFI BIOS flash chip consists of a recovery BIOS block and a main BIOS block (a main BIOS image). The boot block contains critical BIOS codes, including memory detection and recovery codes for the user to flash a new BIOS image if the original main BIOS image is corrupted. When the system power is on, the boot block codes execute first. Once it is completed, the main BIOS code will continue with system initialization and bootup.



**Note:** Follow the BIOS recovery instructions below for BIOS recovery when the main BIOS boot crashes. However, when the BIOS boot block crashes, you will need to follow the procedures below for BIOS recovery.

#### C-3 To Recover the Main BIOS Block Using a USB-Attached Device

This feature allows the user to recover a BIOS image using a USB-attached device without additional utilities used. A USB flash device such as a USB Flash Drive, or a USB CD/DVD ROM/RW device can be used for this purpose. However, a USB Hard Disk drive cannot be used for BIOS recovery at this time.

The file system supported by UEFI is FAT (including FAT12, FAT16, and FAT32) installed on a bootable or non-bootable USB-attached device. However, the BIOS might need several minutes to locate the SUPER.ROM file if the media size becomes too large because it contains too many folders and files.

To perform UEFI BIOS recovery using a USB-attached device, follow the instructions below.

1. Using a different machine, copy the "Super.ROM" binary image file into the disc Root "\\" Directory of a USB device or a writeable CD/DVD.

 **Note:** If you cannot locate the "Super.ROM" file in your driver disk, visit our website at [www.supermicro.com](http://www.supermicro.com) to download the BIOS image into a USB flash device and rename it "Super.ROM" for BIOS recovery use.

2. Insert the USB device that contains the new BIOS image ("Super.ROM") into your USB drive and power on the system
3. While powering on the system, please keep pressing <Ctrl> and <Home> simultaneously on your keyboard *until the following screen (or a screen similar to the one below) displays.*

**Warning!!** Please **stop** pressing the <Ctrl> and <Home> keys immediately when you see the screen (or a similar screen) below; otherwise, it will trigger a system reboot.



 **Note:** On the other hand, if the following screen displays, please load the "Super.ROM" file to the root folder and connect this folder to the system. (You can do so by inserting a USB device that contains the new "Super.ROM" image to your machine for BIOS recovery.)



- After locating the new BIOS binary image, the system will enter the BIOS Recovery menu as shown below.



**Note:** At this point, you may decide if you want to start with BIOS recovery. If you decide to proceed with BIOS recovery, follow the procedures below.

```

Aptio Setup Utility - Copyright (C) 2010 American Megatrends, Inc.
Main  Advanced  Event Logs  IPMI  Boot  Security  Exit  Recovery

WARNING! BIOS Recovery mode has been detected

Flash Update Parameters
Reset NVRAM                               [Enabled]

▶ Proceed with flash update

Select this to start flash update

+-: Select Screen
TI: Select Item
Enter: Select
+/-: Change Opt.
F1: General Help
F2: Previous Values
F3: Optimized Defaults
F4: Save & Exit
ESC: Exit

Version 2.10.1208, Copyright (C) 2010 American Megatrends, Inc.

```

- When the screen as shown above displays, using the arrow key, select the item "Proceed with flash update" and press the <Enter> key. You will see the progress of BIOS recovery as shown in the screen below.



**Note:** Do not interrupt the process of BIOS flashing until it is completed.

```

Aptio Setup Utility - Copyright (C) 2010 American Megatrends, Inc.
Recovery

WARNING! System firmware is being updated.
Keyboard is locked.
DO NOT TURN THE POWER OFF !!!
Once firmware update is completed
press any key to reboot the system

Flash update progress           15 %

+-: Select Screen
TI: Select Item
Enter: Select
+/-: Change Opt.
F1: General Help
F2: Previous Values
F3: Optimized Defaults
F4: Save & Exit
ESC: Exit

Version 2.10.1208, Copyright (C) 2010 American Megatrends, Inc.

```

6. After the process of BIOS recovery is completed, press any key to reboot the system.

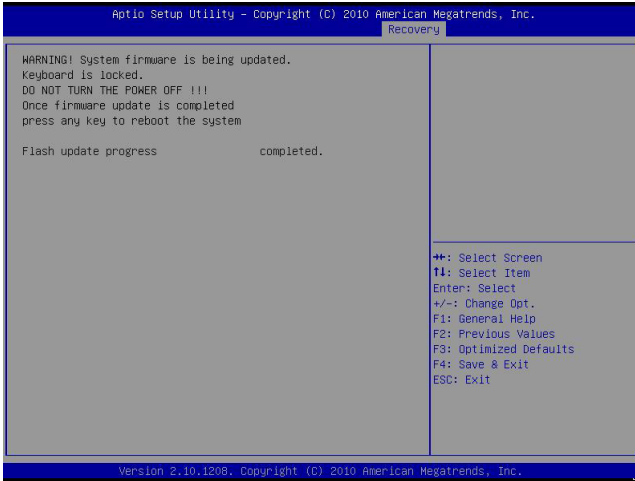

7. Using a different system, extract the BIOS package into a bootable USB flash drive.
8. When a DOS prompt appears, enter FLASH.BAT BIOSName.### at the prompt.



**Note:** *Do not interrupt this process* until BIOS flashing is completed.

9. After seeing the message that BIOS update is completed, unplug the AC power cable from the power supply to clear the CMOS, and then plug the AC power cable in the power supply again to power on the system.
10. Press <Del> continuously to enter the BIOS Setup utility.
11. Press <F3> to load default settings.
12. After loading default settings, press <F4> to save the settings and exit the BIOS Setup utility.

(Disclaimer Continued)

The products sold by Supermicro are not intended for and will not be used in life support systems, medical equipment, nuclear facilities or systems, aircraft, aircraft devices, aircraft/emergency communication devices or other critical systems whose failure to perform be reasonably expected to result in significant injury or loss of life or catastrophic property damage. Accordingly, Supermicro disclaims any and all liability, and should buyer use or sell such products for use in such ultra-hazardous applications, it does so entirely at its own risk. Furthermore, buyer agrees to fully indemnify, defend and hold Supermicro harmless for and against any and all claims, demands, actions, litigation, and proceedings of any kind arising out of or related to such ultra-hazardous use or sale.