

# SUPERO<sup>®</sup>

## SUPER X5DPA-8GG

### USER'S MANUAL

Revision 1.0a

---

The information in this User's Manual has been carefully reviewed and is believed to be accurate. The vendor assumes no responsibility for any inaccuracies that may be contained in this document, makes no commitment to update or to keep current the information in this manual, or to notify any person or organization of the updates.

**Please Note: For the most up-to-date version of this manual, please see our web site at [www.supermicro.com](http://www.supermicro.com).**

SUPERMICRO COMPUTER reserves the right to make changes to the product described in this manual at any time and without notice. This product, including software, if any, and documentation may not, in whole or in part, be copied, photocopied, reproduced, translated or reduced to any medium or machine without prior written consent.

IN NO EVENT WILL SUPERMICRO COMPUTER BE LIABLE FOR DIRECT, INDIRECT, SPECIAL, INCIDENTAL, OR CONSEQUENTIAL DAMAGES ARISING FROM THE USE OR INABILITY TO USE THIS PRODUCT OR DOCUMENTATION, EVEN IF ADVISED OF THE POSSIBILITY OF SUCH DAMAGES. IN PARTICULAR, THE VENDOR SHALL NOT HAVE LIABILITY FOR ANY HARDWARE, SOFTWARE, OR DATA STORED OR USED WITH THE PRODUCT, INCLUDING THE COSTS OF REPAIRING, REPLACING, INTEGRATING, INSTALLING OR RECOVERING SUCH HARDWARE, SOFTWARE, OR DATA.

Any disputes arising between manufacturer and customer shall be governed by the laws of Santa Clara County in the State of California, USA. The State of California, County of Santa Clara shall be the exclusive venue for the resolution of any such disputes. Supermicro's total liability for all claims will not exceed the price paid for the hardware product.

---

Unless you request and receive written permission from SUPER MICRO COMPUTER, you may not copy any part of this document.

Information in this document is subject to change without notice. Other products and companies referred to herein are trademarks or registered trademarks of their respective companies or mark holders.

Copyright © 2003 by SUPER MICRO COMPUTER INC.  
All rights reserved.

**Printed in the United States of America**

# Preface

## About This Manual

This manual is written for system integrators, PC technicians and knowledgeable PC users. It provides information for the installation and use of the X5DPA-8GG mainboard. The X5DPA-8GG supports single or dual Intel® 604 and 603-pin Xeon™ processors at a 533/400 MHz front side bus. Please refer to the support section of our web site (<http://www.supermicro.com/TechSupport.htm>) for a complete listing of supported processors. This product is intended to be professionally installed.

## Manual Organization

**Chapter 1** begins with a checklist of what should be included in your mainboard box, describes the features, specifications and performance of the motherboard and provides detailed information about the chipset.

**Chapter 2** begins with instructions on handling static-sensitive devices. Read this chapter when you want to install the processor and DIMM memory modules and when mounting the mainboard in the chassis. Also refer to this chapter to connect the floppy and hard disk drives, SCSI drives, the IDE interfaces, the parallel and serial ports, the keyboard and mouse, the power supply and various control panel buttons and indicators.

If you encounter any problems, see **Chapter 3**, which describes troubleshooting procedures for the video, the memory and the setup configuration stored in CMOS. For quick reference, a general FAQ [Frequently Asked Questions] section is provided. Instructions are also included for contacting technical support. In addition, you can visit our web site (at [www.supermicro.com/techsupport.htm](http://www.supermicro.com/techsupport.htm)) for more detailed information.

**Chapter 4** includes an introduction to BIOS and provides detailed information on running the CMOS Setup utility.

**Appendix A** gives information on BIOS POST messages.

**Appendix B** provides BIOS POST codes.

**Appendix C** provides Software Installation Instructions.

---



---

## Table of Contents

### Preface

About This Manual .....	iii
Manual Organization .....	iii

### Chapter 1: Introduction

1-1 Overview .....	1-1
Checklist .....	1-1
Contacting Supermicro .....	1-2
Super X5DPA-8GG Image .....	1-3
Super X5DPA-8GG Layout .....	1-4
Super X5DPA-8GG Quick Reference .....	1-5
Motherboard Features .....	1-6
Intel E7501 Chipset: System Block Diagram .....	1-8
1-2 Chipset Overview .....	1-9
1-3 Special Features .....	1-9
ATI Graphics Controller .....	1-9
Recovery from AC Power Loss .....	1-9
1-4 PC Health Monitoring .....	1-11
1-5 ACPI Features .....	1-12
1-6 Power Supply .....	1-13
1-7 Super I/O .....	1-14

### Chapter 2: Installation

2-1 Static-Sensitive Devices .....	2-1
Precautions .....	2-1
Unpacking .....	2-1
2-2 PGA Processor and Heatsink Installation .....	2-2
2-3 Installing DIMMs .....	2-5
2-4 I/O Ports/Control Panel Connectors .....	2-6
2-5 Connecting Cables .....	2-8
ATX Power Connection .....	2-8
PWR_SEC Connection .....	2-8
Power LED .....	2-9
NMI Button .....	2-9
HDD LED .....	2-9
NIC1 LED .....	2-10
NIC2 LED .....	2-10
Overheat LED .....	2-10

Reset Button .....	2-11
Power Button .....	2-11
Power Fail Button .....	2-11
Back Panel Universal Serial Bus (USB0/1) .....	2-12
Front Panel Universal Serial Bus Headers (USB0/1) and USB2 ...	2-12
Serial Ports .....	2-13
GLAN1/2 (Ethernet Ports) .....	2-13
Fan Headers .....	2-14
SMB (System Management Bus) .....	2-14
Power LED/Speaker/NMI Header (JD1) .....	2-15
ATX PS/2 Keyboard and Mouse Ports .....	2-15
Wake-On-LAN .....	2-16
Wake-On-Ring .....	2-16
Keylock .....	2-17
Chassis Intrusion .....	2-17
2-6 Jumper Settings .....	2-18
Explanation of Jumpers .....	2-18
CMOS Clear .....	2-19
GLAN Enable/Disable .....	2-20
VGA Enable/Disable .....	2-20
Front Side Bus Speed .....	2-21
Watch Dog Enable/Disable .....	2-21
SCSI Enable/Disable .....	2-22
SCSI Termination Enable/Disable .....	2-22
Force-Power-On Enable/Disable .....	2-23
2-7 Onboard Indicators .....	2-23
GLAN1/GLAN2 LEDs .....	2-23
2-8 Parallel Port, Floppy/Hard Disk Drive and IPMI Connections .....	2-24
IPMI Socket .....	2-24
Floppy Connector .....	2-24
SCSI Connectors .....	2-25
IDE Connectors .....	2-26

## Chapter 3: Troubleshooting

3-1 Troubleshooting Procedures .....	3-1
Before Power On .....	3-1
No Power .....	3-1
No Video .....	3-1
Memory Errors .....	3-2

Losing the System's Setup Configuration .....	3-2
3-2 Technical Support Procedures .....	3-2
3-3 Frequently Asked Questions .....	3-3
3-4 Returning Merchandise for Service .....	3-4

## **Chapter 4: BIOS**

4-1 Introduction .....	4-1
4-2 MainSetup .....	4-2
4-3 Advanced BIOS Setup .....	4-5
4-4 Boot Setup .....	4-18
4-5 Security Setup .....	4-20
4-6 Exit Options .....	4-21

## **Appendices:**

Appendix A: BIOS POST Messages .....	A-1
Appendix B: BIOS POST Codes .....	B-1
Appendix C: Software Installation Instructions .....	C-1

# Chapter 1

## Introduction

### 1-1 Overview

#### Checklist

Congratulations on purchasing your computer motherboard from an acknowledged leader in the industry. Supermicro boards are designed with the utmost attention to detail to provide you with the highest standards in quality and performance.

Please check that the following items have been included with your motherboard. If anything listed here is damaged or missing, contact your retailer.

One (1) Supermicro Mainboard

One (1) ribbon cable for IDE devices

One (1) floppy ribbon cable

One (1) USB cable

One (1) COM Port Cable with Bracket

One (1) SCSI cable (034-u320)

One (1) I/O backpanel shield

One (1) Supermicro CD or diskettes containing drivers and utilities

One (1) User's/BIOS Manual

Two (2) CPU/Heatsink Plates (SKT-120-P) and two (2) heatsink retention clips (SKT-095-604 E)

## Contacting Supermicro

### Headquarters

Address: SuperMicro Computer, Inc.  
980 Rock Ave.  
San Jose, CA 95131 U.S.A.

Tel: +1 (408) 503-8000

Fax: +1 (408) 503-8008

Email: [marketing@supermicro.com](mailto:marketing@supermicro.com) (General Information)  
[support@supermicro.com](mailto:support@supermicro.com) (Technical Support)

Web Site: [www.supermicro.com](http://www.supermicro.com)

### Europe

Address: SuperMicro Computer B.V.  
Het Sterrenbeeld 28, 5215 ML  
's-Hertogenbosch, The Netherlands

Tel: +31 (0) 73-6400390

Fax: +31 (0) 73-6416525

Email: [sales@supermicro.nl](mailto:sales@supermicro.nl) (General Information)  
[support@supermicro.nl](mailto:support@supermicro.nl) (Technical Support)  
[rma@supermicro.nl](mailto:rma@supermicro.nl) (Customer Support)

### Asia-Pacific

Address: SuperMicro, Taiwan  
D5, 4F, No. 16 Chien-Ba Road  
Chung-Ho 235, Taipei Hsien, Taiwan, R.O.C.

Tel: +886-(2) 8226-3990

Fax: +886-(2) 8226-3991

Web Site: [www.supermicro.com.tw](http://www.supermicro.com.tw)

Technical Support:

Email: [support@supermicro.com.tw](mailto:support@supermicro.com.tw)

Tel: 886-2-8228-1366, ext.132 or 139

Figure 1-2. SUPER X5DPA-8GG Image



**Figure 1-5. SUPER X5DPA-8GG Layout\***  
(not drawn to scale)

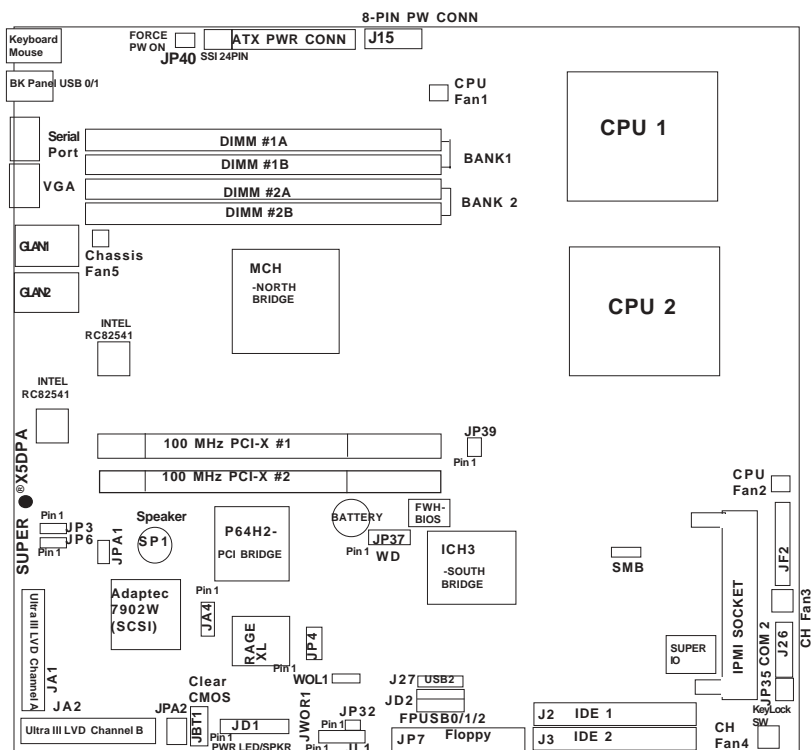

**Notes:**

1. The CPU sockets are designed for the 604-Pin Xeon Processors; however, the 603-Pin CPUs are also supported. When one CPU is used, please install it in CPU Socket #1.
2. DIMM memory modules have to be used in pairs. When one pair of DIMMs are used, please install them in the Bank #1.

## X5DPA-8GG Quick Reference

<b><u>Jumper</u></b>	<b><u>Description</u></b>	<b><u>Default Setting</u></b>
JBT1	CMOS Clear Pad	See Jumper Section
JD1	PWR LED/Speaker Header	Pins 6-7 (Onboard Speaker)
JA4	SCSI Enable/Disable	Pins 1-2 (Enabled)
JP3,JP6	GLAN1/GLAN2 Enable/Disable	Pins 1-2 (Enabled)
JP4	VGA Enable/Disable	Pins 1-2 (Enabled)
JP37	Watch Dog (Reset NMI*)	Pins 2-3 NMI>(*Note)
JP39	CPU Clock	Pins 1-2 (Auto)
JP40	Force Power ON	Open (Disabled)
JPA1	SCSI Channel A Termination	Enable/Disable Open (Enabled)
JPA2	SCSI Channel B Termination	Enable/Disable Open (Enabled)

<b><u>Connector</u></b>	<b><u>Description</u></b>
ATX PWR CONN	Primary ATX Power Connector
DIMM#1A-DIMM#2B	Memory (RAM) Slots
CPU/Chassis FAN(5)	CPU1Fan, CPU2 Fan, Chassis Fan3/4/5
LAN1,LAN2	GLAN1, GLAN2(Gigabit Ethernet Port 1 & 2)
J2,J3	IDE#1(J2), IDE#2(J3) HDD Connectors
J4	VGA Connector
J8, J26	COM1(SerialPort1-J8),COM2(SerialPort2-J26)
J10,J11	Back Panel USB 0/1Ports (J10:USB 0, J11: USB 1)
JD2, J27	Front Panel USB Ports (JD2: FPUSB0/1, J27:USB2)
J15	Secondary ATX Power (8-Pin) Connector
J22	IPMI Socket
J28	PS/2 Keyboard & PS/2 Mouse
JA1,JA2	Ultra III LVD Channel A, Channel B
JF2	Front Control Panel Connector
JK1, JK5	GLAN RJ45 Connectors
JL1	Chassis Intrusion Header
JP7	Floppy Disk Drive Connector
JP24	SMB Header
JP35	Keylock Switch Connector
JWOR1	Wake-on-Ring Header
WOL1	Wake-on-LAN Header

(\*Note: NMI: Non Maskable Interrupt)

## Motherboard Features

### CPU

- Single or dual Intel® 604-Pin Xeon™ processors at a 533/400 MHz front side (system) bus speed. (603-Pin Xeon supported) **Note:** Please refer to the support section of our web site for a complete listing of supported processors (<http://www.supermicro.com/TechSupport.htm>).

### Memory

- Four 184-pin DIMM sockets supporting up to 8 GB of registered ECC DDR-266/200 SDRAM

#### (\*Note:

1. Interleaved memory; requires memory modules to be installed in pairs. DDR-266 memory must be used with 533 MHz FSB speed processors. See Section 2-3 for details.
2. DDR 266(PC2100) memory is supported, but will only run at 200MHz if 400MHz FSB CPUs are used.
3. Non-ECC, unbuffered memory modules are not supported.)

### Chipset

- Intel E7501 chipset

### Expansion Slots

- TWO 64-bit, 133/100/66 MHz PCI-X (3.3 V)

### BIOS

- 4 Mb AMI Flash ROM
- APM 1.2, DMI 2.1, PCI 2.2, ACPI 1.0, Plug and Play (PnP), SMBIOS 2.3

### PC Health Monitoring

- Onboard voltage monitors for CPU cores, 3.3V,+12V,-12V and 3.3V standby
- Fan status monitor with firmware/software on/off control
- CPU/chassis temperature monitors
- Environmental temperature monitor and control
- CPU fan auto-off in sleep mode
- CPU slow-down on temperature overheat
- CPU overheat LED header
- Power-up mode control for recovery from AC power loss

- Auto-switching voltage regulator for CPU core
- System overheat LED and control
- Chassis intrusion detection
- System resource alert

#### **ACPI Features (optional)**

- Microsoft OnNow
- Slow blinking LED for suspend state indicator
- Main switch override mechanism

#### **Onboard I/O**

- Integrated ATI Rage XL graphics controller
- Intel Gigabit LAN (Ethernet) 82541 controller (\* two GLAN ports on the X5DPA-8GG)
- 2 EIDE Ultra DMA/100 bus master interfaces
- Adaptec 7902 Dual Channel Ultra 320 SCSI
- 1 floppy port interface (up to 2.88 MB)
- 2 Fast UART 16550A compatible serial port and header
- PS/2 mouse and PS/2 keyboard ports
- Up to 5 USB (Universal Serial Bus) ports

#### **Other**

- Internal/external modem ring-on
- Wake-on-LAN (WOL)
- Console redirection
- IPMI supported

#### **CD/Diskette Utilities**

- BIOS flash upgrade utility and device drivers

#### **Dimensions**

- ATX: 12" x 10" (304.8 x 254 mm)

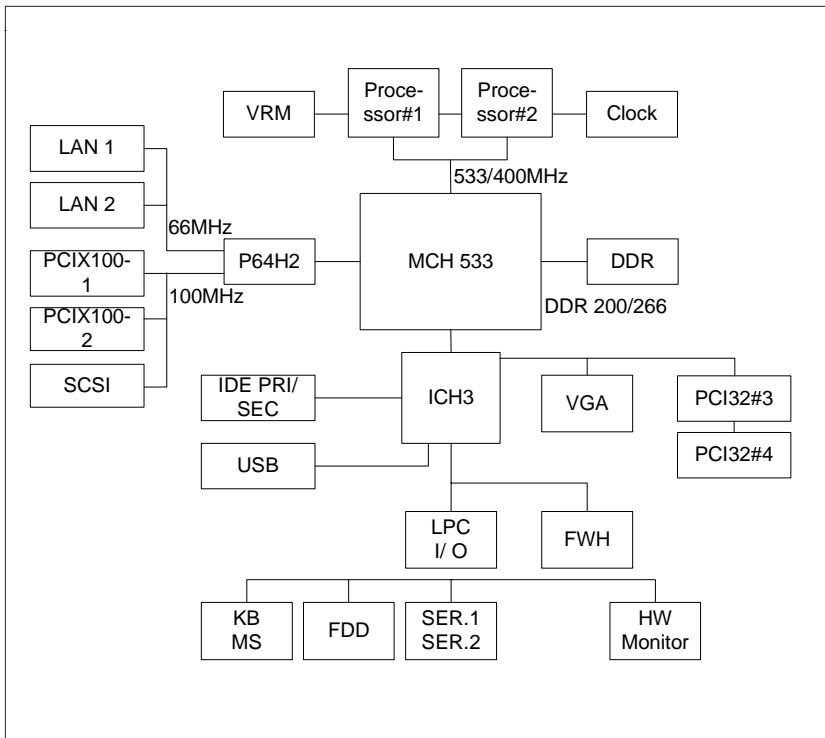

Figure 1-5. X5DPA: Intel E7501 Chipset Block Diagram

**Note:** This is a general block diagram. Please see the previous Motherboard Features pages for details on the features of each motherboard.

## 1-2 Intel E7501 Chipset Overview

The Intel E7501 chipset is a high-performance chipset with a performance and feature-set designed for mid-range, dual processor servers. The E7501 chipset consists of four major components: the Memory Controller Hub (MCH), the I/O Controller Hub 3 (ICH3), the PCI-X 64-bit Hub 2.0 (P64H2) and the FW82801CA FIRMWARE Controller.

The MCH has four hub interfaces, one to communicate with the ICH3 and three for high-speed I/O communications. The MCH employs a 144-bit wide memory bus for a DDR-266 memory interface, which provides a total bandwidth of 3.2 GB/s. The ICH3 interface is a 266 MB/sec point-to-point connection using an 8-bit wide, 66 MHz base clock at a 4x data transfer rate. The P64H2 interface is a 1 GB/s point-to-point connection using a 16-bit wide, 66 MHz base clock at a 8x data transfer rate.

The ICH3 I/O Controller Hub provides various integrated functions, including a two-channel UDMA100 bus master IDE controller, USB host controllers, a System Management Bus controller and an AC'97 compliant interface.

The P64H2 PCI-X Hub provides a 16-bit connection to the MCH for high-performance I/O capability and two 64-bit PCI-X interfaces.

## 1-3 Special Features

### ATI Graphics Controller

The X5DPA-8GG has an integrated ATI video controller based on the Rage XL graphics chip. The Rage XL fully supports sideband addressing and AGP texturing. This onboard graphics package can provide a bandwidth of up to 512 MB/sec over a 32-bit graphics memory bus.

### Recovery from AC Power Loss

BIOS provides a setting for you to determine how the system will respond when AC power is lost and then restored to the system. You can choose for the system to remain powered off (in which case you must hit the power switch to turn it back on) or for it to automatically return to a power-on state. See the Power Lost Control setting in the AMI BIOS Utility to change this setting.

## **64-bit PCI/PCI-X Interface**

- PCI-X Rev. 1.0 Compliant 64-bit bus, up to 133MHz
- Supports 64-bit addressing via Dual Address Cycle (DAC) Transactions
- Compliant with PCI Power Management (PMG)

### **Features**

- Supports up to four split transactions (PCI-X)
- Supports UP TO 4 MB expansion ROM for add-in cards
- Serial EPROM initialization interface
- PCI Plug-and-Play support

## 1-4 PC Health Monitoring

This section describes the PC health monitoring features of the SUPER X5DPA-8GG. All have an onboard System Hardware Monitor chip that supports PC health monitoring.

### **Onboard Voltage Monitors for the CPU Cores,+3.3V,+12V,-12V and +3.3V Standby**

An onboard voltage monitor will scan these voltages continuously. Once a voltage becomes unstable, a warning is given or an error message is sent to the screen. Users can adjust the voltage thresholds to define the sensitivity of the voltage monitor.

### **Fan Status Monitor with Firmware/Software On/Off Control**

The PC health monitor can check the RPM status of the cooling fans. The onboard 3-pin CPU and chassis fans are controlled by the power management functions.

### **Environmental Temperature Control**

The thermal control sensor monitors the CPU temperature in real time and will turn on the thermal control fan whenever the CPU temperature exceeds a user-defined threshold. The overheat circuitry runs independently from the CPU. It can continue to monitor for overheat conditions even when the CPU is in sleep mode. Once it detects that the CPU temperature is too high, the Overheat buzzer and the LED will be automatically activated. The onboard chassis thermal circuitry can monitor the overall system temperature and alert users when the chassis temperature is too high.

### **CPU Fan Auto-Off in Sleep Mode**

The CPU fan activates when the power is turned on. It continues to operate when the system enters Standby mode. When in sleep mode, the CPU will not run at full power, thereby generating less heat.

### **CPU Overheat LED and Control**

This feature is available when the user enables the CPU overheat warning function in the BIOS. This allows the user to define an overheat temperature. When this temperature is exceeded, both the overheat buzzer and the warning LED are triggered.

---

## **Auto-Switching Voltage Regulator for the CPU Core**

The auto-switching voltage regulator for the CPU core can support up to 20A current and auto-sense voltage IDs ranging from 1.4V to 3.5V. This will allow the regulator to run cooler and thus make the system more stable.

## **1-5 ACPI Features**

ACPI stands for Advanced Configuration and Power Interface. The ACPI specification defines a flexible and abstract hardware interface that provides a standard way to integrate power management features throughout a PC system, including its hardware, operating system and application software. This enables the system to automatically turn on and off peripherals such as CD-ROMs, network cards, hard disk drives and printers. This also includes consumer devices connected to the PC such as VCRs, TVs, telephones and stereos.

In addition to enabling operating system-directed power management, ACPI provides a generic system event mechanism for Plug and Play and an operating system-independent interface for configuration control. ACPI leverages the Plug and Play BIOS data structures while providing a processor architecture-independent implementation that is compatible with both Windows 2000 and Windows NT 5.0.

### **Microsoft OnNow**

The OnNow design initiative is a comprehensive, system-wide approach to system and device power control. OnNow is a term for a PC that is always on but appears to be off and responds immediately to user or other requests.

### **Slow Blinking LED for Suspend-State Indicator**

When the CPU goes into a suspend state, the chassis power LED will start blinking to indicate that the CPU is in suspend mode. When the user presses any key, the CPU will wake-up and the LED will automatically stop blinking and remain on.

## **Main Switch Override Mechanism**

When an ATX power supply is used, the power button can function as a system suspend button to make the system enter a SoftOff state. The monitor will be suspended and the hard drive will spin down. Depressing the power button again will cause the whole system to wake-up. During the SoftOff state, the ATX power supply provides power to keep the required circuitry in the system alive. In case the system malfunctions and you want to turn off the power, just depress and hold the power button for 4 seconds. This option can be set in the "BIOS features" under the "Advanced Menu."

## **External Modem Ring-On**

Wake-up events can be triggered by a device such as the external modem ringing when the system is in the SoftOff state. Note that external modem ring-on can only be used with an ATX 2.01 (or above) compliant power supply.

## **Wake-On-LAN (WOL)**

Wake-On-LAN is defined as the ability of a management application to remotely power up a computer that is powered off. Remote PC setup, updates and asset tracking can occur after hours and on weekends so that daily LAN traffic is kept to a minimum and users are not interrupted. The motherboards have a 3-pin header (WOL) to connect to the 3-pin header on a Network Interface Card (NIC) that has WOL capability. Wake-On-LAN must be enabled in BIOS. Note that Wake-On-Lan can only be used with an ATX 2.01 (or above) compliant power supply.

## **1-6 Power Supply**

As with all computer products, a stable power source is necessary for proper and reliable operation. It is even more important for processors that have high CPU clock rates.

The SUPER X5DPA-8GG accommodates ATX power supplies. Although most power supplies generally meet the specifications required by the CPU, some are inadequate. You should use one that will supply at least 350W of power and includes the additional +12V, 8-pin power connector - an even higher wattage power supply is recommended for high-load configurations. Also your power supply must supply 1.5A for LAN1 and LAN2.

## (\*NOTES:

Auxiliary 12v power (J15) is necessary to support Intel Xeon CPUs. Failure to provide this extra power will result in the CPUs becoming unstable after only a few minutes of operation. See Section 2-5 for details on connecting the power supply cables.

It is strongly recommended that you use a high quality power supply that meets ATX power supply Specification 2.02 or above. It must also be SSI compliant (info at <http://www.ssiforum.org/>). Additionally, in areas where noisy power transmission is present, you may choose to install a line filter to shield the computer from noise. It is recommended that you also install a power surge protector to help avoid problems caused by power surges.

## 1-7 Super I/O

The disk drive adapter functions of the Super I/O chip include a floppy disk drive controller that is compatible with industry standard 82077/765, a data separator, write pre-compensation circuitry, decode logic, data rate selection, a clock generator, drive interface control logic and interrupt and DMA logic. The wide range of functions integrated onto the Super I/O greatly reduces the number of components required for interfacing with floppy disk drives. The Super I/O supports 360 K, 720 K, 1.2 M, 1.44 M or 2.88 M disk drives and data transfer rates of 250 Kb/s, 500 Kb/s or 1 Mb/s. It also provides two high-speed, 16550 compatible serial communication ports(UARTs), one of which supports serial infrared communication. Each UART includes a 16-byte send/receive FIFO, a programmable baud rate generator, complete modem control capability and a processor interrupt system. Each UART includes a 16-byte send/receive FIFO, a programmable baud rate generator, complete modem control capability and a processor interrupt system. Both UARTs provide legacy speed with baud rate of up to 115.2 Kbps as well as an advanced speed with baud rates of 250 K, 500 K, or 1 Mb/s, which support higher speed modems.

The Super I/O provides functions that comply with ACPI (Advanced Configuration and Power Interface), which includes support of legacy and ACPI power management through an SMI or SCI function pin. It also features auto power management to reduce power consumption.

The IRQs, DMAs and I/O space resources of the Super I/O can flexibly adjust to meet ISA PnP requirements, which support ACPI and APM (Advanced Power Management).

## Chapter 2 Installation

### 2-1 Static-Sensitive Devices

Electric-Static-Discharge (ESD) can damage electronic components. To prevent damage to your system board, it is important to handle it very carefully. The following measures are generally sufficient to protect your equipment from ESD.

#### Precautions

- Use a grounded wrist strap designed to prevent static discharge.
- Touch a grounded metal object before removing the board from the anti-static bag.
- Handle the board by its edges only; do not touch its components, peripheral chips, memory modules or gold contacts.
- When handling chips or modules, avoid touching their pins.
- Put the motherboard and peripherals back into their antistatic bags when not in use.
- For grounding purposes, make sure your computer chassis provides excellent conductivity between the power supply, the case, the mounting fasteners and the motherboard.

#### Unpacking

The motherboard is shipped in antistatic packaging to avoid static damage. When unpacking the board, make sure the person handling it is static protected.

## 2-2 PGA Processor and Heatsink Installation



*When handling the processor package, avoid placing direct pressure on the label area of the fan. Also, do not place the motherboard on a conductive surface, which can damage the BIOS battery and prevent the system from booting up.*

**IMPORTANT:** Always connect the power cord last and always remove it before adding, removing or changing any hardware components. Make sure that you install the processor into the CPU socket **before** you install the CPU heat sink.

1. Locate the following components, which are included in the shipping package.

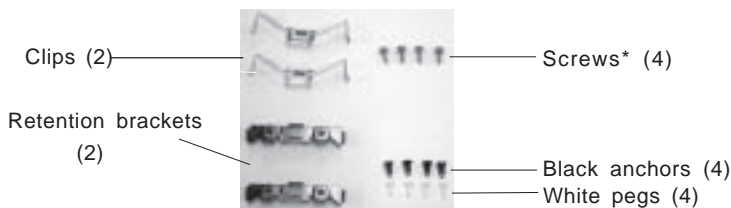

\*These screws are for mounting the motherboard to the back panel of a chassis that has four mounting holes (as shown on right).

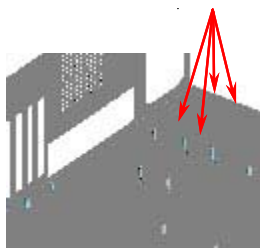

For chassis that do not have four mounting holes, use the anchor/peg assemblies:

2. Insert the white pegs into the black anchors. Do not force the white pegs all the way in - only about 1/3 of the way into the black anchors.

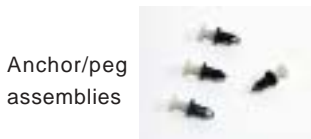

Anchor/peg assemblies  
Two pegs in position

3. Place a retention bracket in the proper position and secure it by pressing pegs into two of the retention holes until you hear a \*click\*. The clicking sound indicates that the peg is locked and secured.

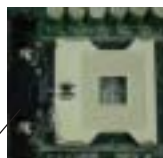

One retention bracket in position

4. Secure the other retention bracket into position by repeating Step 3.



5. Lift the lever on the CPU socket: lift the lever completely and fully (\*120° to 135° for Xeon CPUs as shown on right), or you will damage the CPU socket when power is applied. (Install CPU1 first.)

Socket lever



Open 120° to 135° for Xeon CPUs

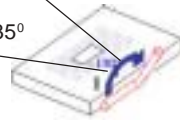

6. Install the CPU in the socket. Make sure that pin 1 of the CPU is seated on pin 1 of the socket (both corners are marked). When using only one CPU, install it into CPU socket #1 (CPU socket #2 is automatically disabled if only one CPU is used).

Pin 1

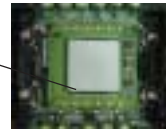

7. Press the lever down until you hear it \*click\* into the locked position.

Heatsink

8. Apply the proper amount of thermal glue to the CPU die and place the heatsink and fan on top of the CPU.

Fan

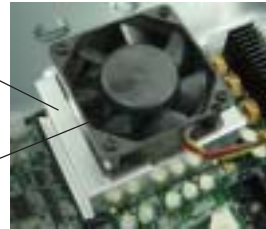

9. Secure the heatsink by locking the retention clips into their proper position.

Retention clip



10. Connect the three wires of the CPU fan to the respective CPU fan connector.

CPU fan wires

CPU fan connector

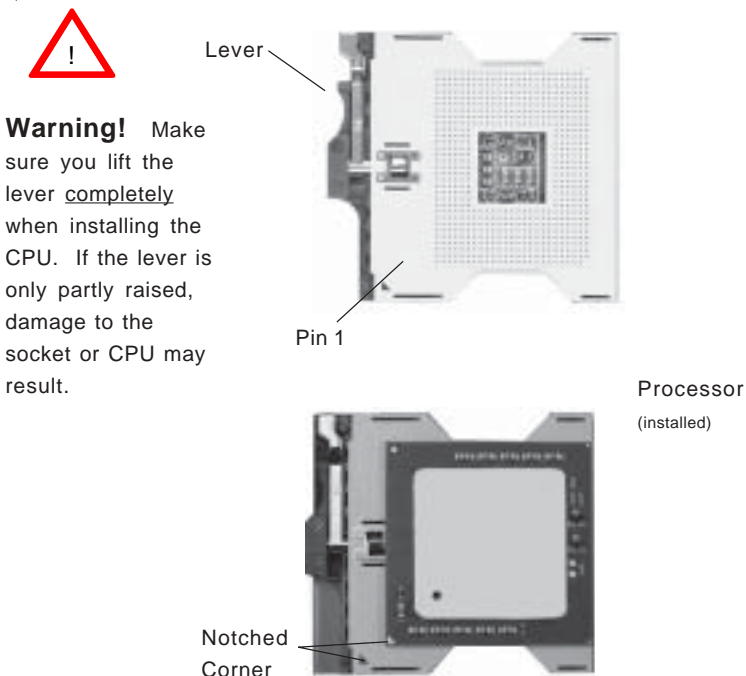

**Figure 2-1. PGA604 Socket: Empty and with Processor Installed**

### Mounting the Motherboard in the Chassis

All motherboards have standard mounting holes to fit different types of chassis. Make sure the location of all the mounting holes for both the motherboard and the chassis match. Although a chassis may have both plastic and metal mounting fasteners, metal ones are highly recommended because they ground the motherboard to the chassis. Make sure the metal standoffs click in or are screwed in tightly. Then use a screwdriver to secure the motherboard onto the motherboard tray.

## 2-3 Installing DIMMs

**Note:** Check the Supermicro web site for recommended memory modules:  
[http://www.supermicro.com/TECHSUPPORT/FAQs/Memory\\_vendors.htm](http://www.supermicro.com/TECHSUPPORT/FAQs/Memory_vendors.htm)

### CAUTION

Exercise extreme care when installing or removing DIMM modules to prevent any possible damage. Also note that the memory is interleaved to improve performance (see step 1).

### DIMM Installation (See Figure 2-2)

1. Insert the desired number of DIMMs into the memory slots, starting with Bank 1. The memory scheme is interleaved so you must install two modules at a time, beginning with Bank 1, then Bank 2.
2. Insert each DIMM module vertically into its slot. Pay attention to the notch along the bottom of the module to prevent inserting the DIMM module incorrectly.
3. Gently press down on the DIMM module until it snaps into place in the slot. Repeat for all modules (see step 1 above).

### Memory Support

The X5DPA-8GG only supports ECC registered DDR-266/200 MHz SDRAM memory. If you are using 533 MHz front side bus processor(s), you must use DDR-266 SDRAM. If you are using 400 MHz front side bus processor(s), you may use either DDR-266 or DDR-200 SDRAM. However, if 400 MHz FSB CPUs are used, DDR-266 will run at 200 MHz.

**Figure 2-2. Installing and Removing DIMMs**

**To Install:**  
 Insert module vertically and press down until it snaps into place. Pay attention to the alignment notch at the bottom.

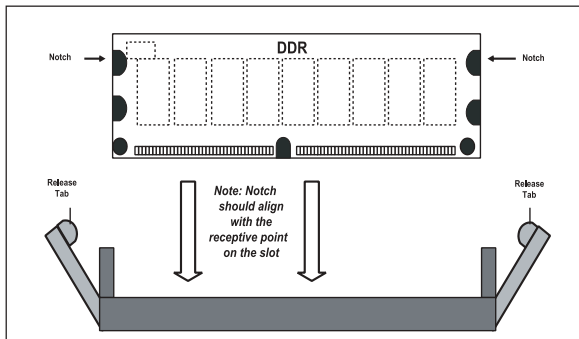

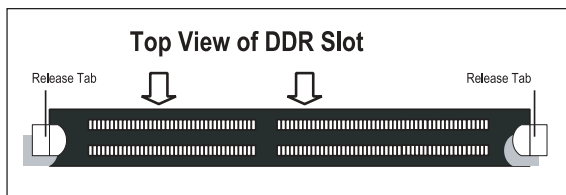

**To Remove:**

Use your thumbs to gently push near the edge of both ends of the module. This should release it from the slot.

## 2-4 I/O Ports/Control Panel Connectors

The I/O ports are color coded in conformance with the PC 99 specification. See Figure 2-3 below for the colors and locations of the various I/O ports.

**Figure 2-3. I/O Port Locations and Definitions**



**Notes:** COM2 is a header located on the motherboard - see the motherboard layout pages in Chapter 1 for location.

## Front Control Panel

JF2 contains header pins for various buttons and indicators that are normally located on a control panel at the front of the chassis. These connectors are designed specifically for use with Supermicro server chassis. See Figure 2-4 for the descriptions of the various control panel buttons and LED indicators. Refer to the following section for descriptions and pin definitions.

**Figure 2-4. JF2 Header Pins**

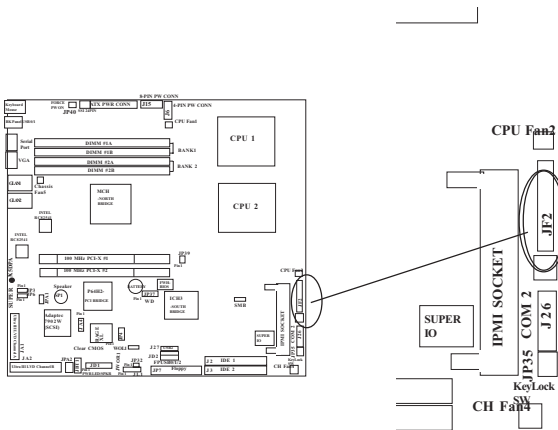
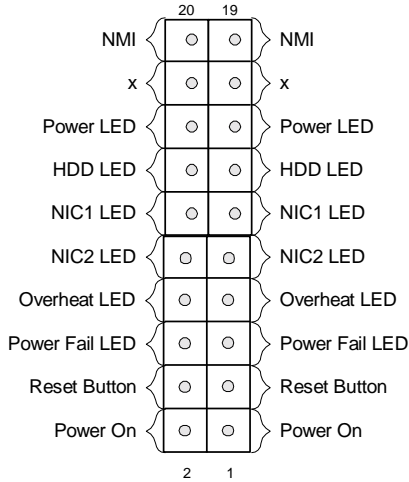

## 2-5 Connecting Cables

### ATX Power Connection

The X5DPA-8GG power supply connector meets the SSI (Superset ATX) 24-pin specification, however it also supports a 20-pin power supply connector. Make sure that the orientation of the PS connector is correct. The X5DPA-8GG has the 24-pin connector. See the tables on the right for pin definitions.

ATX Power Supply 24-pin Connector Pin Definitions

Pin Number	Definition	Pin Number	Definition
13	+3.3V	1	+3.3V
14	-12V	2	+3.3V
15	COM	3	COM
16	PS_ON#	4	+5V
17	COM	5	COM
18	COM	6	+5V
19	COM	7	COM
20	Res(NC)	8	PWR_OK
21	+5V	9	5VSB
22	+5V	10	+12V
23	+5V	11	+12V
24	COM	12	+3.3V

### PWR\_SEC Connection

In addition to the Primary ATX power connector (above), the Secondary 12v 8-pin J15 connector must also be connected to your power supply. See the table on the right for pin definitions.

8-Pin +12v Power Supply Connector (J15)

Pins	Definition
1 thru 4	Ground
5 thru 8	+12v

JF2

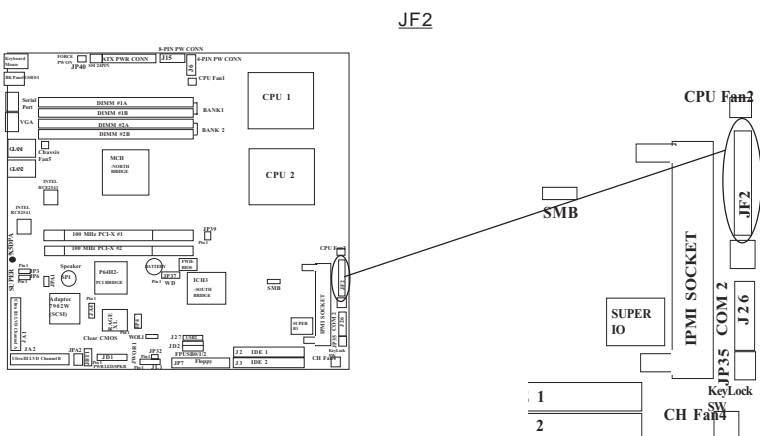

## Power LED

The Power LED connection is located on pins 15 and 16 of JF2. Refer to the table on the right for pin definitions.

**PWR\_LED Pin Definitions (JF2)**

Pin Number	Definition
15	Vcc
16	Control

## NMI Button

The non-maskable interrupt button header is located on pins 19 and 20 of JF2. Refer to the table on the right for pin definitions.

**NMI Button Pin Definitions (JF2)**

Pin Number	Definition
19	Control
20	Ground

## HDD LED

The HDD LED (for IDE and SCSI Disk Drives) connection is located on pins 13 and 14 of JF2. Attach the IDE hard drive LED cable to these pins to display disk activity. Refer to the table on the right for pin definitions.

**HDD LED Pin Definitions (JF2)**

Pin Number	Definition
13	Vcc
14	HD Active

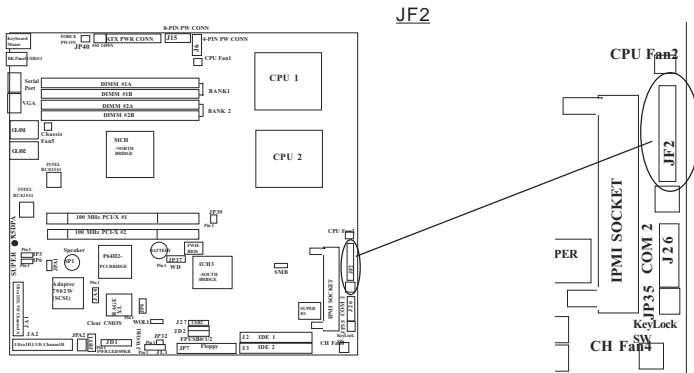

### NIC1 LED

The NIC1 (Network Interface Controller) LED connection is located on pins 11 and 12 of JF2. Attach the NIC1 LED cable to display network activity. Refer to the table on the right for pin definitions.

**NIC1 LED Pin Definitions (JF2)**

Pin Number	Definition
11	Vcc
12	GND

### NIC2 LED

The NIC2 (Network Interface Controller) LED connection is located on pins 9 and 10 of JF2. Attach the NIC2 LED cable to display network activity. Refer to the table on the right for pin definitions.

**NIC2 LED Pin Definitions (JF2)**

Pin Number	Definition
9	Vcc
10	GND

### Overheat LED (OH)

Connect an LED to the OH connection on pins 7 and 8 of JF2 to provide advanced warning of chassis overheating. Refer to the table on the right for pin definitions.

**Overheat (OH) LED Pin Definitions (JF2)**

Pin Number	Definition
7	Vcc
8	GND

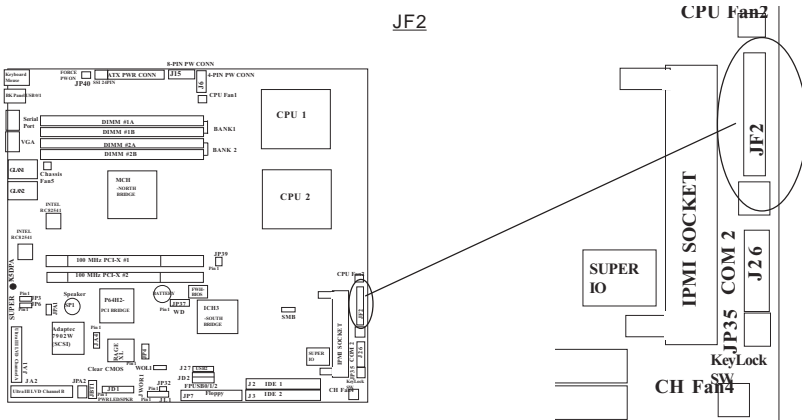

## Reset Button

The Reset Button connection is located on pins 3 and 4 of JF2. Attach it to the hardware reset switch on the computer case. Refer to the table on the right for pin definitions.

**Reset Pin Definitions (JF2)**

Pin Number	Definition
3	Reset
4	Ground

## Power Button

The Power Button connection is located on pins 1 and 2 of JF2. Momentarily contacting both pins will power on/off the system. This button can also be configured to function as a suspend button (see the Power Button Mode setting in BIOS). To turn off the power when set to suspend mode, depress the button for at least 4 seconds. Refer to the table on the right for pin definitions.

**Power Button Connector Pin Definitions (JF2)**

Pin Number	Definition
1	PW_ON
2	Ground

## Power Fail LED

The Power Fail LED connection is located on pins 5 and 6 of JF2. Refer to the table on the right for pin definitions.

**Power Fail LED Pin Definitions (JF2)**

Pin Number	Definition
5	Vcc
6	GND

JF2

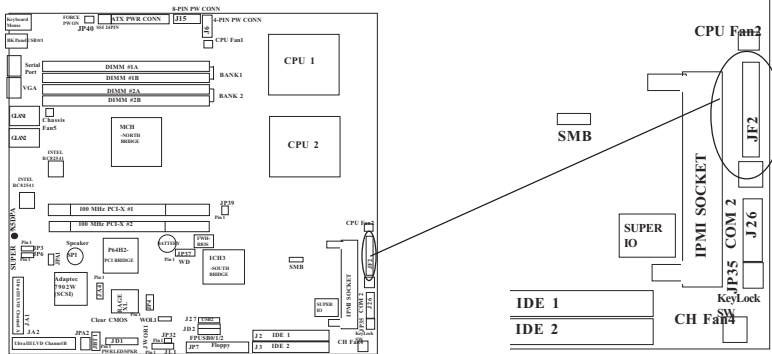

## Back Panel Universal Serial Bus (USB0/1)

Two Universal Serial Bus ports (J10, J11) are located beside the PS/2 keyboard/mouse ports. USB0 is the bottom connector and USB1 is the top connector. See the table on the right for pin definitions.

Back Panel Universal Serial Bus Pin Definitions (J10, J11)

USB0		USB1	
Pin Number	Definition	Pin Number	Definition
1	+5V	1	+5V
2	P0-	2	P0-
3	P0+	3	P0+
4	Ground	4	Ground

## Front Panel USB 0/1 & USB 2

Three Front Panel USB Headers (JD2, J27) can be used for front side USB access. These USB headers are located next to the Floppy Disk Connector. You will need a USB cable (CBL 031 included) to use either connection. Refer to the tables on the right for pin definitions.

Front Panel Universal Serial Bus Pin Definitions  
USB0/1(JD2)      USB2(J27)

USB0/1(JD2)		USB2(J27)	
Pin Number	Definition	Pin Number	Definition
1	+5V	1	+5V
2	P0-	2	P0-
3	P0+	3	P0+
4	Ground	4	Ground
5	Key	5	N/A

## Back Panel Universal Serial Bus (USB0/1)

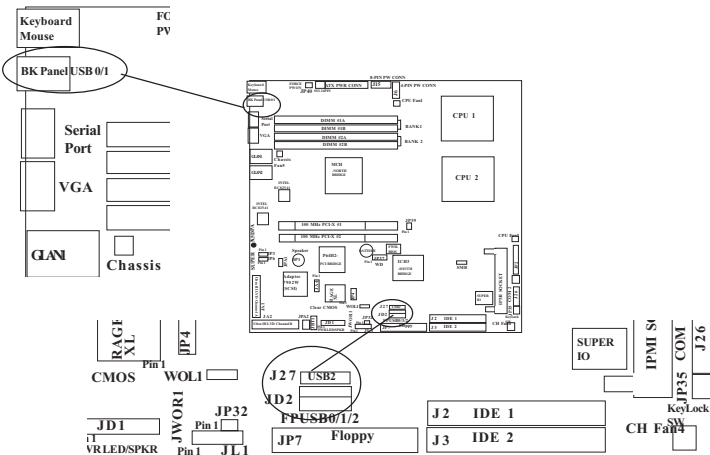

Front Panel USB 0/1 & USB 2

## Serial Ports

The COM1(J8) serial port is located next to the USB 0/1 ports. COM 2 is located at the corner near PCI-33 Slots. (See MB layouts in Chapter 1). See the table on the right for pin definitions. The COM2(J26) connector is a header on the motherboard (see pp. 1-6, 1-8 for location).

**Serial Port Pin Definitions  
(COM1, COM2)**

Pin Number	Definition	Pin Number	Definition
1	CD	6	DSR
2	RD	7	RTS
3	TD	8	CTS
4	DTR	9	RI
5	Ground	10	NC

**Note:** Pin 10 is included on the header but not on the port.

## Ethernet Ports GLAN1/2

Two Ethernet ports (designated GLAN1 and GLAN2) are located beside the VGA port on the IO backplane. These ports accept RJ45 type cables.



### COM1(J8) serial port

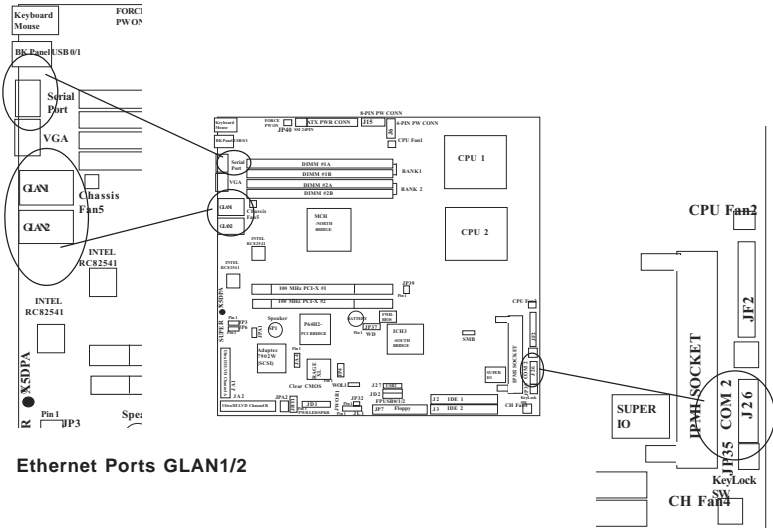

Ethernet Ports GLAN1/2

COM2(J26) serial port

## Fan Headers

The X5DPA-8GG has five CPU, chassis fan headers. Designations include CPU1Fan, CPU2Fan, Chassis Fan3, Chassis Fan4, and Chassis Fan5. See the table on the right for pin definitions.

**Fan Header Pin Definitions**

Pin Number	Definition
1	Ground (black)
2	+12V (red)
3	Tachometer

Caution: These fan headers are DC power.

## SMB

A System Management Bus header is located at J24. Connect the appropriate cable here to utilize SMB on your system.

**SMB Header Pin Definitions (J24)**

Pin Number	Definition
1	Data
2	Ground
3	Clock
4	No Connection

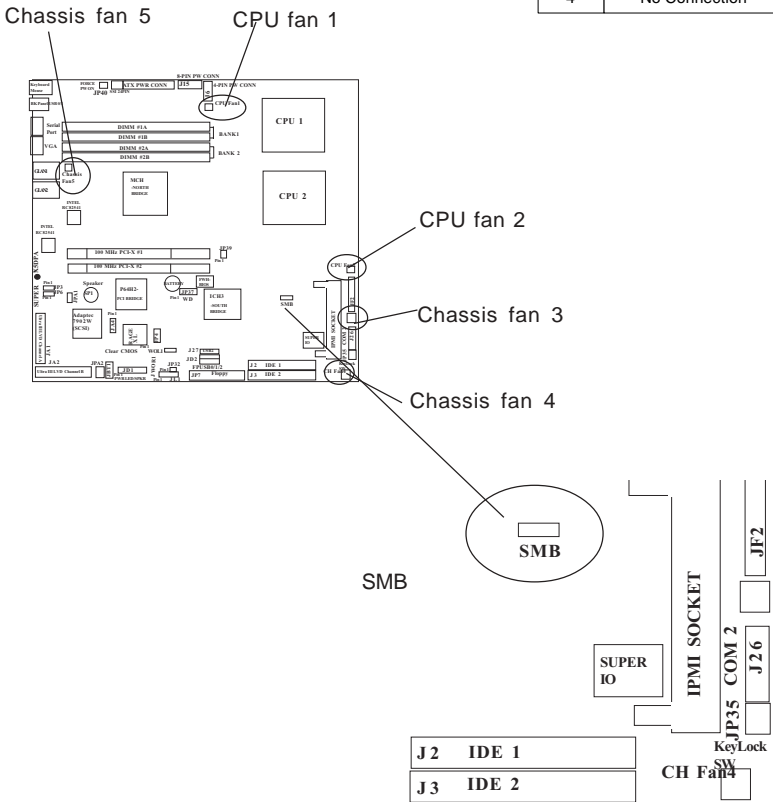

## Power LED/Speaker/NMI

On the JD1 header, pins 1-3 are for a Power LED, pins 4-7 are for the speaker. See the table on the right for speaker pin definitions. **Note:** The speaker connector pins are for use with an external speaker. If you wish to use the onboard speaker, you should close pins 6-7 with a jumper.

**Speaker Connector Pin Definitions (JD1)**

Pin Number	Function	Definition
4	+ Key	Red wire, Speaker data
5		No connection
6		Key
7		Speaker data

## ATX PS/2 Keyboard and PS/2 Mouse Ports

The ATX PS/2 keyboard and PS/2 mouse are located on J28 on the X5DPA-8GG. See the table at right for pin definitions. (See Figure 2-3 for the locations of each.)

**PS/2 Keyboard and Mouse Port Pin Definitions (J28)**

Pin Number	Definition
1	Data
2	NC
3	Ground
4	VCC
5	Clock
6	NC

## Keyboard and PS/2 Mouse

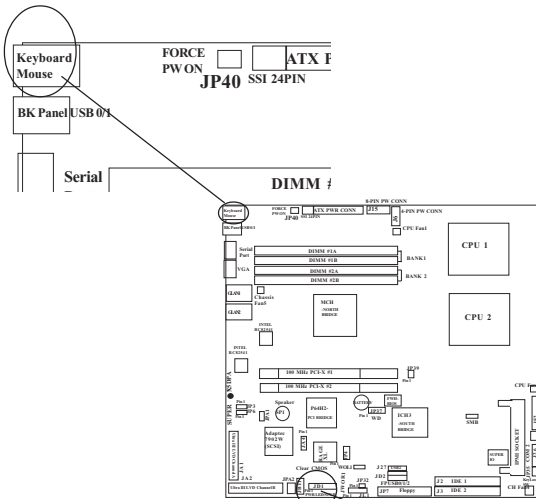

**Power LED/Speaker/NMI**

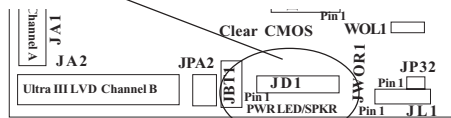

### Wake-On-LAN

The Wake-On-LAN header is designated WOL1. See the table on the right for pin definitions. You must enable the LAN Wake-Up setting in BIOS to use this feature. You must also have a LAN card with a Wake-on-LAN connector and cable.

**Wake-On-LAN Pin Definitions (WOL1)**

Pin Number	Definition
1	+5V Standby
2	Ground
3	Wake-up

### Wake-On-Ring

The Wake-On-Ring header is designated JWOR1. This function allows your computer to receive and "wake-up" by an incoming call to the modem when in suspend state. See the table on the right for pin definitions. You must have a Wake-On-Ring card and cable to use this feature.

**Wake-on-Ring Pin Definitions (JWOR1)**

Pin Number	Definition
1	Ground
2	Wake-up

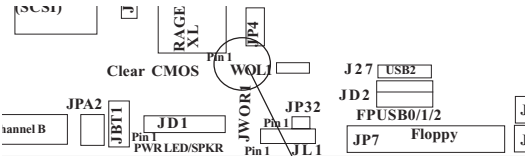

### Wake-On-LAN

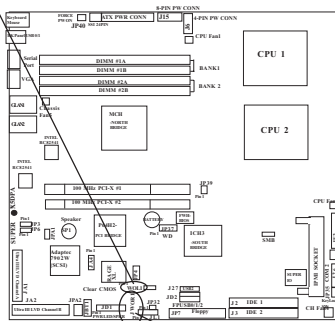

### Wake-On-Ring

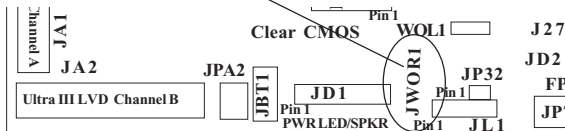

## Keylock

The keyboard lock connection is located on JP35. Utilizing this header allows you to inhibit any actions made on the keyboard, effectively "locking" it.

## Chassis Intrusion

A Chassis Intrusion header is located at JL1. Attach the correct connector here to inform you of a chassis intrusion condition.

**Chassis Intrusion  
Pin Definitions (JL1)**

Pin Number	Definition
1	Intrusion Input
2	Ground

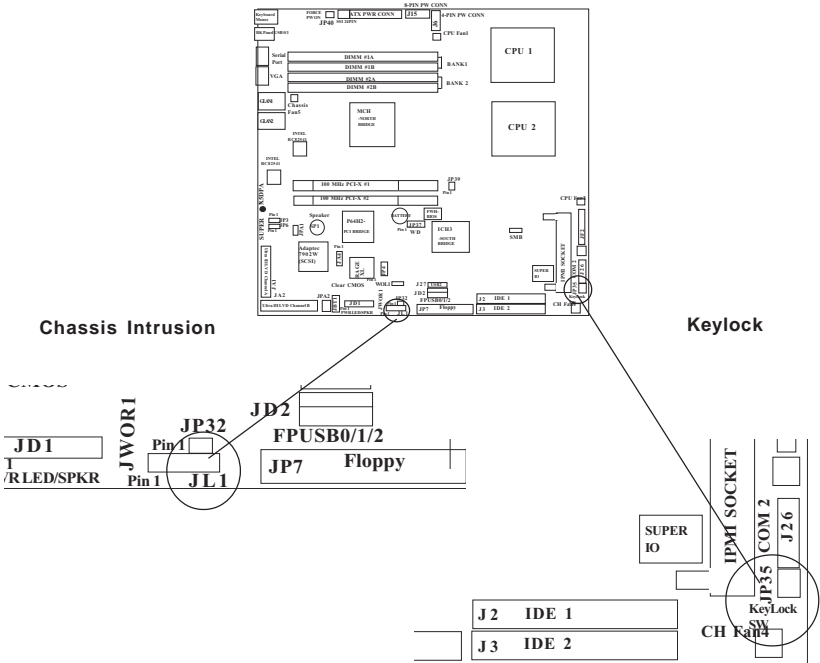

## 2-6 Jumper Settings

### Explanation of Jumpers

To modify the operation of the motherboard, jumpers can be used to choose between optional settings. Jumpers create shorts between two pins to change the function of the connector. Pin 1 is identified with a square solder pad on the printed circuit board. See the motherboard layout pages for jumper locations.

**Note:** On two pin jumpers, "Closed" means the jumper is on and "Open" means the jumper is off the pins.

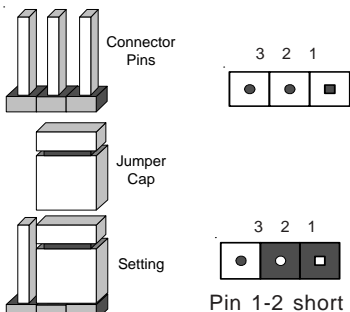

## CMOS Clear

JBT1 is not literally a jumper but consists of two contact pads. To clear the contents of CMOS, short these pads together by touching them both with a metal conductor such as the head of a small screwdriver. For ATX power supplies, you must completely shut down the system and remove the AC power cord before clearing CMOS.

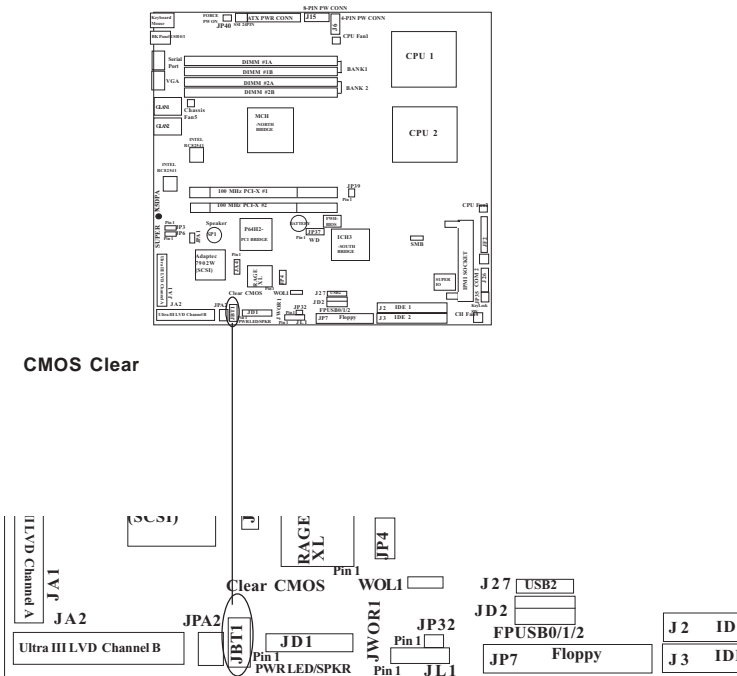

### GLAN Enable/Disable

Change the setting of JP3 to enable or disable the onboard GLAN1. Change the setting of JP6 to enable or disable the onboard GLAN2. See the table on the right for jumper settings. The default setting is enabled.

**LAN Enable/Disable Jumper Settings (JP3: LAN 1, JP6: LAN2)**

Jumper Position	Definition
Pins 1-2	Enabled
Pins 2-3	Disabled

### VGA Enable/Disable

JP4 allows you to enable or disable the VGA port. The default position is on pins 1 and 2 to enable VGA. See the table on the right for jumper settings.

**VGA Enable/Disable Jumper Settings (JP4)**

Jumper Position	Definition
1-2	Enabled
2-3	Disabled

### GLAN Enable/Disable

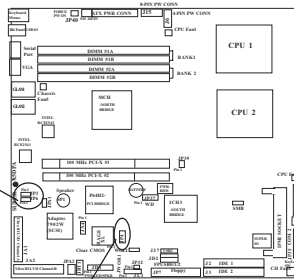
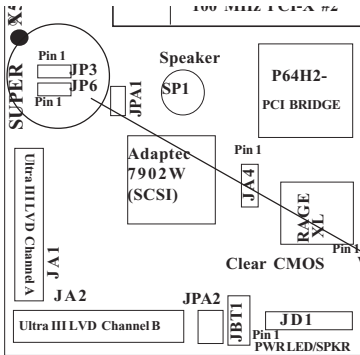

### VGA Enable/Disable

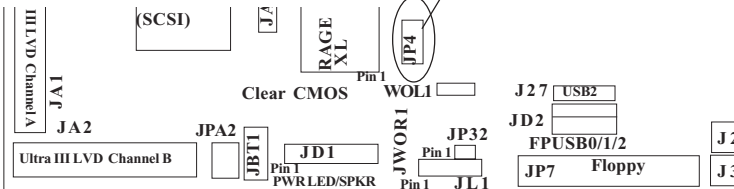

## Front Side Bus Speed

JP39 (see motherboard layout ) is used to set the system (front side) bus speed for the processors. It is best to keep this jumper set to Auto. This jumper is used together with the CPU Clock setting in BIOS. See the table on the right for jumper settings.

**Front Side Bus Speed Jumper Settings (JP39)**

Jumper Position	Definition
Pins 1-2	Auto
Pins 2-3	400 MHz
Open	533 MHz

## Watch Dog Enable/Disable

JP37 allows you to enable or disable the functions of Watch Dog. See the table on the right for jumper settings. Close Pins 1-2 for reset. Close Pins 2-3 to activate the function of NMI (Non Maskable Interrupt).

**Watch Dog Enable/Disable Jumper Settings (JP37)**

Jumper Position	Definition
1-2	Reset
2-3	NMI

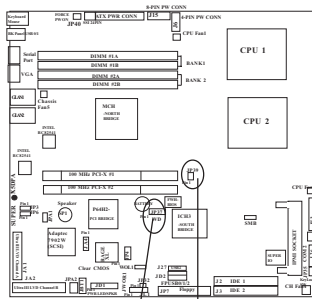

**Front Side Bus Speed**

## Watch Dog Enable/Disable

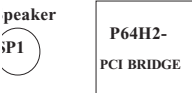
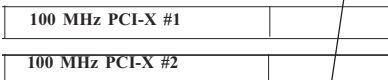

### SCSI Enable/Disable

The SCSI Enable/Disable jumper at JA4 allows you to enable or disable the onboard SCSI. The normal (default) position is on pins 1-2 to enable SCSI. See the table on the right for jumper settings.

**SCSI Enable/Disable Jumper Settings (JA4)**

Jumper Position	Definition
Pins 1-2	Enabled
Pins 2-3	Disabled

### SCSI Termination Enable/Disable

Jumpers JPA1 and JPA2 allow you to enable or disable termination for the SCSI connectors. Jumper JPA1 controls SCSI channel A and JPA2 is for SCSI channel B. The default setting is open to enable (terminate) both SCSI channels. See the table on the right for jumper settings.

**SCSI Channel Termination Enable/Disable Jumper Settings (JPA1, JPA2)**

Jumper Position	Definition
Open	Enabled
Closed	Disabled

### SCSI Enable/Disable

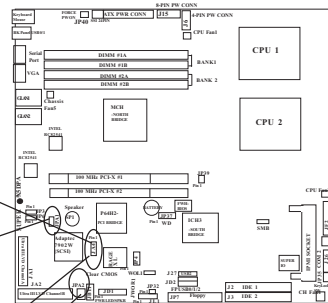

### SCSI Termination Enable/Disable

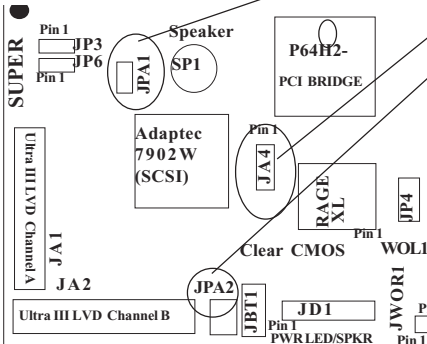

## Force-Power-On Enable/Disable

Jumper JP40 allow you to enable or disable the function of Force-Power-On. If enabled, the power will always stay on automatically. If this function disabled, the user needs to press the power button to power on the system.

**Force-Power-On Enable/Disable Jumper Settings (JP40)**

Jumper Position	Definition
Open	Enabled
Closed	Disabled

## 2-7 Onboard Indicators

### GLAN1/GLAN2 LEDs

The Ethernet ports (located beside the VGA port) have two LEDs. See the table on the right for the functions associated with these LEDs. On each GLAN port, the yellow LED indicates activity while the other LED may be green, orange or off to indicate the speed of the connection.

**GLAN LED Indicators**

LED Color	Definition
Off	No Connection
Green	100 MHz
Orange	1 GHz

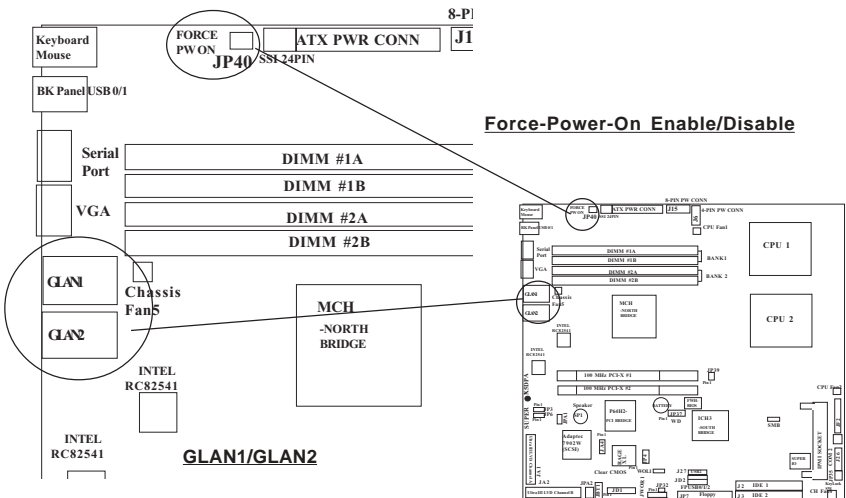

## 2-8 Floppy/Hard DiskDrive, IPMI and SCSI Connections

Note the following when connecting the floppy and hard disk drive cables:

- The floppy disk drive cable has seven twisted wires.
- A red mark on a wire typically designates the location of pin 1.
- A single floppy disk drive ribbon cable has 34 wires and two connectors to provide for two floppy disk drives. The connector with twisted wires always connects to drive A, and the connector that does not have twisted wires always connects to drive B.

### IPMI

J22 is designated as the IPMI Socket for the X5DPA-8GG Motherboard.

Floppy Connector Pin Definitions (JP7)

### Floppy Connector

The floppy connector is located on JP7. See the table below for pin definitions.

Pin Number	Function	Pin Number	Function
1	GND	2	FDHDIN
3	GND	4	Reserved
5	Key	6	FDEDIN
7	GND	8	Index-
9	GND	10	Motor Enable
11	GND	12	Drive Select B-
13	GND	14	Drive Select A-
15	GND	16	Motor Enable
17	GND	18	DIR-
19	GND	20	STEP-
21	GND	22	Write Data-
23	GND	24	Write Gate-
25	GND	26	Track 00-
27	GND	28	Write Protect-
29	GND	30	Read Data-
31	GND	32	Side 1 Select-
33	GND	34	Diskette

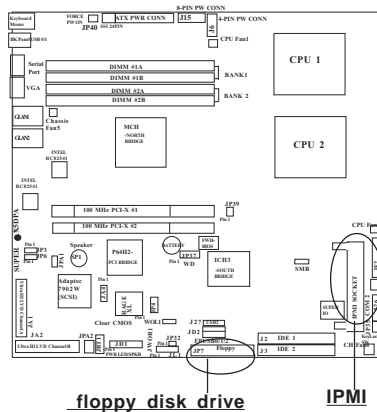

## Ultra320 SCSI Connectors

Refer to the table below for the pin definitions of the Ultra320 SCSI connectors located at JA1 and JA2.

68-pin Ultra320 SCSI Connectors (JA1 and JA2)

Connector Contact Number	Signal Names	Connector Contact Number	Signal Names
1	+DB(12)	35	-DB(12)
2	+DB(13)	36	-DB(13)
3	+DB(14)	37	-DB(14)
4	+DB(15)	38	-DB(15)
5	+DB(P1)	39	-DB(P1)
6	+DB(0)	40	-DB(0)
7	+DB(1)	41	-DB(1)
8	+DB(2)	42	-DB(2)
9	+DB(3)	43	-DB(3)
10	+DB(4)	44	-DB(4)
11	+DB(5)	45	-DB(5)
12	+DB(6)	46	-DB(6)
13	+DB(7)	47	-DB(7)
14	+DB(P)	48	-DB(P)
15	GROUND	49	GROUND
16	DIFFSENS	50	GROUND
17	TERMPWR	51	TERMPWR
18	TERMPWR	52	TERMPWR
19	RESERVED	53	RESERVED
20	GROUND	54	GROUND
21	+ATN	55	-ATN
22	GROUND	56	GROUND
23	+BSY	57	-BSY
24	+ACK	58	-ACK
25	+RST	59	-RST
26	+MSG	60	-MSG
27	+SEL	61	-SEL
28	+C/D	62	-C/D
29	+REQ	63	-REQ
30	+I/O	64	-I/O
31	+DB(8)	65	-DB(8)
32	+DB(9)	66	-DB(9)
33	+DB(10)	67	-DB(10)
34	+DB(11)	68	-DB(11)

### SCSI Connectors

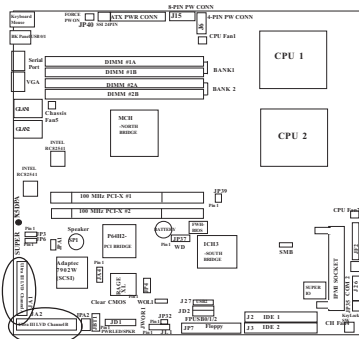

## IDE Connectors

There are no jumpers to configure the onboard IDE#1(J2) and IDE#2 (J3) connectors. See the table on the right for pin definitions.

IDE Connector Pin Definitions  
(IDE#1, IDE#2)

Pin Number	Function	Pin Number	Function
1	Reset IDE	2	GND
3	Host Data 7	4	Host Data 8
5	Host Data 6	6	Host Data 9
7	Host Data 5	8	Host Data 10
9	Host Data 4	10	Host Data 11
11	Host Data 3	12	Host Data 12
13	Host Data 2	14	Host Data 13
15	Host Data 1	16	Host Data 14
17	Host Data 0	18	Host Data 15
19	GND	20	Key
21	DRQ3	22	GND
23	I/O Write	24	GND
25	I/O Read	26	GND
27	IOCHRDY	28	BALE
29	DACK3-	30	GND
31	IRQ14	32	IOCS16-
33	Addr 1	34	GND
35	Addr 0	36	Addr 2
37	Chip Select 0	38	Chip Select 1-
39	Activity	40	GND

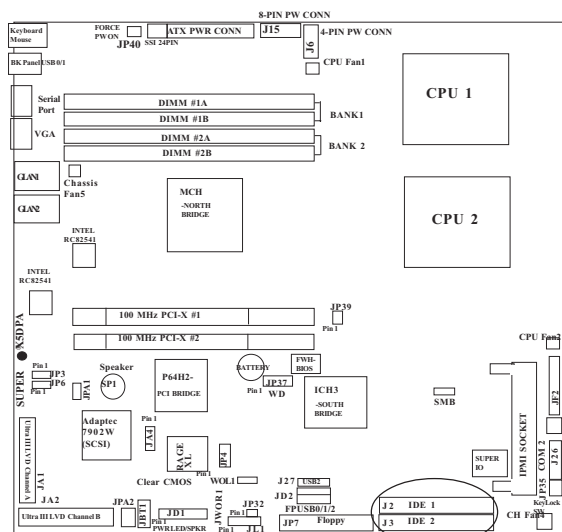

IDE Connectors

(\*Note: For software installation instructions, please refer to Appendix C.)

## Chapter 3

# Troubleshooting

### 3-1 Troubleshooting Procedures

Use the following procedures to troubleshoot your system. If you have followed all of the procedures below and still need assistance, refer to the 'Technical Support Procedures' and/or 'Returning Merchandise for Service' section(s) in this chapter.

**Note: Always disconnect the power cord before adding, changing or installing any hardware components.**

#### Before Power On

1. Make sure no short circuits exist between the motherboard and chassis.
2. Disconnect all ribbon/wire cables from the motherboard, including those for the keyboard and mouse.
3. Remove all add-on cards.
4. Install one CPU (making sure it is fully seated) and connect the chassis speaker and the power LED to the motherboard. (Check all jumper settings as well.)

#### No Power

1. Make sure no short circuits exist between the motherboard and the chassis.
2. Verify that all jumpers are set to their default positions.
3. Check that the 115V/230V switch on the power supply is properly set.
4. Turn the power switch on and off to test the system.
5. The battery on your motherboard may be old. Check to verify that it still supplies ~3VDC. If it does not, replace it with a new one.

#### No Video

1. If the power is on but you have no video, remove all the add-on cards and cables.
2. Use the speaker to determine if any beep codes exist. Refer to the Appendix for details on beep codes.

### **NOTE**

If you are a system integrator, VAR or OEM, a POST diagnostics card is recommended. For I/O port 80h codes, refer to App. B.

---

## **Memory Errors**

1. Make sure the DIMM modules are properly and fully installed.
2. Determine if different speeds of DIMMs have been installed and verify that the BIOS setup is configured for the fastest speed of RAM used. It is recommended to use the same RAM speed for all DIMMs in the system.
3. Make sure you are using registered ECC, DDR-266 or DDR-200 SDRAM. (\*Non ECC, unbuffered memory modules are not supported.) If using 533 MHz processors, you must use DDR-266 memory (DDR-200 is not supported at a 533 MHz front side bus speed). However, if 400 FSB processors are used, DDR-266 memory will run at 200 MHz.
4. Check for bad DIMM modules or slots by swapping a single module between two slots and noting the results.
5. Make sure all memory modules are fully seated in their slots. As an interleaved memory scheme is used, you must install two modules at a time, beginning with Bank 1, then Bank 2, and so on (see Section 2-3).
6. Check the power supply voltage 115V/230V switch.

## **Losing the System's Setup Configuration**

1. Ensure that you are using a high quality power supply. A poor quality power supply may cause the system to lose the CMOS setup information. Refer to Section 1-6 for details on recommended power supplies.
2. The battery on your motherboard may be old. Check to verify that it still supplies ~3VDC. If it does not, replace it with a new one.
3. If the above steps do not fix the Setup Configuration problem, contact your vendor for repairs.

## **3-2 Technical Support Procedures**

Before contacting Technical Support, please take the following steps. Also, note that as a motherboard manufacturer, Super Micro does not sell directly to end-users, so it is best to first check with your distributor or reseller for troubleshooting services. They should know of any possible problem(s) with the specific system configuration that was sold to you.

---

1. Please go through the 'Troubleshooting Procedures' and 'Frequently Asked Question' (FAQ) sections in this chapter or see the FAQs on our web site (<http://www.supermicro.com/TECHSUPPORT/techsupport.htm>) before contacting Technical Support.
2. BIOS upgrades can be downloaded from our web site at <http://www.supermicro.com/techsupport/download.htm>.  
***Note: Not all BIOS can be flashed depending on the modifications to the boot block code.***
3. If you still cannot resolve the problem, include the following information when contacting Super Micro for technical support:
  - Motherboard model and PCB revision number
  - BIOS release date/version (this can be seen on the initial display when your system first boots up)
  - System configurationAn example of a Technical Support form is on our web site at [http://www.supermicro.com/techsupport/contact\\_support.htm](http://www.supermicro.com/techsupport/contact_support.htm).
4. Distributors: For immediate assistance, please have your account number ready when placing a call to our technical support department. We can be reached by e-mail at [support@supermicro.com](mailto:support@supermicro.com) or by fax at: (408) 503-8000, option 2.

### 3-3 Frequently Asked Questions

**Question: What are the various types of memory that my motherboard can support?**

**Answer:** The X5DPA-8GG has four DIMM slots that support 184-pin, registered ECC DDR-266 or DDR-200 SDRAM DIMM modules. If using 533 MHz processors, you must use DDR-266 memory (DDR-200 is not supported at a 533 MHz front side bus speed). It is strongly recommended that you do not mix memory modules of different speeds and sizes. Unbuffered SDRAM, non-ECC memory and PC100/133 SDRAM modules are not supported.

**Question: How do I update my BIOS?**

**Answer:** It is recommended that you do not upgrade your BIOS if you are experiencing no problems with your system. Updated BIOS files are located on our web site at <http://www.supermicro.com>. Please check our BIOS warning message and the info on how to update your BIOS on our web

site. Also, check the current BIOS revision and make sure it is newer than your BIOS before downloading.

**Question: What's on the CD that came with my motherboard?**

**Answer:** The supplied compact disc has quite a few drivers and programs that will greatly enhance your system. We recommend that you review the CD and install the applications you need. Applications on the CD include chipset drivers for Windows and security and audio drivers.

**Question: Why can't I turn off the power using the momentary power on/off switch?**

**Answer:** The instant power off function is controlled in BIOS by the Power Button Mode setting. When the On/Off feature is enabled, the motherboard will have instant off capabilities as long as the BIOS has control of the system. When the Standby or Suspend feature is enabled or when the BIOS is not in control such as during memory count (the first screen that appears when the system is turned on), the momentary on/off switch must be held for more than four seconds to shut down the system. This feature is required to implement the ACPI features on the motherboard.

### **3-4 Returning Merchandise for Service**

A receipt or copy of your invoice marked with the date of purchase is required before any warranty service will be rendered. You can obtain service by calling your vendor for a Returned Merchandise Authorization (RMA) number. When returning to the manufacturer, the RMA number should be prominently displayed on the outside of the shipping carton, and mailed prepaid or hand-carried. Shipping and handling charges will be applied for all orders that must be mailed when service is complete.

This warranty only covers normal consumer use and does not cover damages incurred in shipping or from failure due to the alternation, misuse, abuse or improper maintenance of products.

During the warranty period, contact your distributor first for any product problems.

# Chapter 4

## AMIBIOS

### 4-1 Introduction

This chapter describes the AMIBIOS for the X5DPA-8GG. The AMI ROM BIOS is stored in a Flash EEPROM and can be easily upgraded using a floppy disk-based program. This chapter describes the basic navigation of the AMI BIOS Setup Utility setup screens.

#### Starting BIOS Setup Utility

To enter the AMI BIOS Setup Utility screens, hit the <Delete> key while the system is booting-up.

(\*Note: In most cases, the <Delete> key is used to invoke the BIOS setup screen. There are a few cases when other keys are used, such as <F1>, <F2>, and so on.)

Each main BIOS menu option is described in this user's guide. The Main BIOS setup menu screen has two main frames. The left frame displays all the options that can be configured. "Grayed-out" options cannot be configured. Options in blue can be configured by the user. The right frame displays the key legend. Above the key legend is an area reserved for a text message. When an option is selected in the left frame, it is highlighted in white. Often a text message will accompany it.

(\*Note: AMIBIOS has default text messages built in. Supermicro retains the option to include, omit, or change any of these text messages.)

The AMI BIOS setup/utility uses a key-based navigation system called hot keys. Most of the BIOS setup utility hot keys can be used at any time during the setup navigation process. These keys include <F1>, <F10>, <Enter>, <ESC>, <Arrow> keys, and so on.

(\*Note: Options printed in **Bold** are default settings.)

## 4-2 Main Setup

When you first enter the BIOS Setup Utility, you will enter the Main setup screen. You can always return to the Main setup screen by selecting the **Main** tab on the top of the screen. The Main BIOS Setup screen is shown below.



### System Time/System Date

Use this option to change the system time and date. Highlight *System Time* or *System Date* using the <Arrow> keys. Enter new values through the keyboard. Press the <Tab> key or the <Arrow> keys to move between fields. The date must be entered in MM/DD/YY format. The time is entered in HH:MM:SS format.

**\*Note:** The time is in 24-hour format. For example, 5:30 A.M. appears as 05:30:00, and 5:30P.M. as 17:30:00.

### Floppy Diskette Device

Move the cursor to these fields via up and down <arrow> keys. Select the floppy type. The options are "Disabled", "360 KB 5 1/4", "1.2 MB 5 1/4", "720 KB 3 1/2", "1.44 MB 3 1/2", and "2.88 MB 3 1/2".

## ► Primary IDE Master/Slave, Secondary IDE Master/Slave Sub Menu

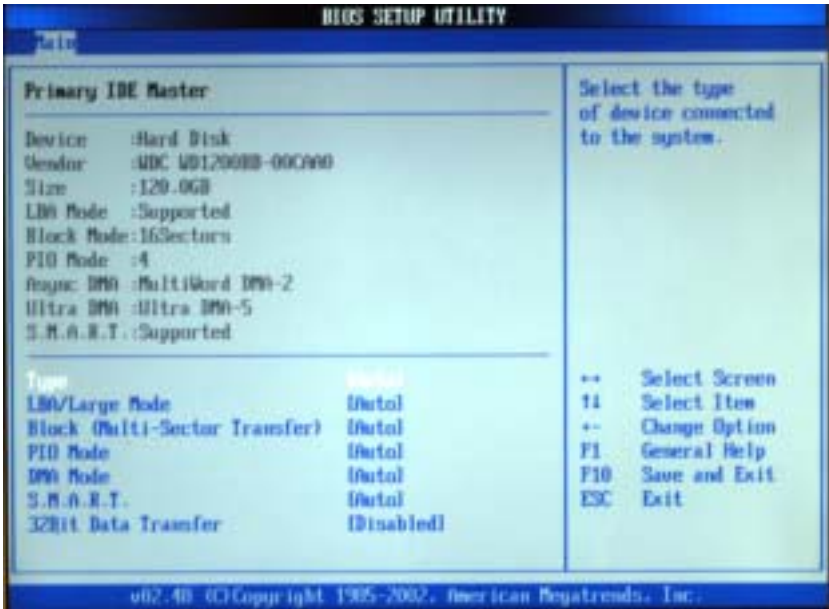

### ► Primary and Secondary IDE Master and Slave Settings

From the Main Setup screen, press <Enter> to access the sub menu for the primary and secondary IDE master and slave drives. Use this screen to select options for the Primary and Secondary IDE drives. Use the up and down <Arrow> keys to select an item. Use the <Plus> and <Minus> keys to change the value of the selected option. The settings are described on the following pages. The screen for the Primary IDE Master is shown below.

#### Type

Select the type of device connected to the system. The options are "Not Installed", "**Auto**", "CDROM" and "ARMD".

#### LBA/Large Mode

LBA (Logical Block Addressing) is a method of addressing data on a disk drive. In LBA mode, the maximum drive capacity is 137 GB. For drive capacities over 137 GB, your system must be equipped with 48-bit LBA mode addressing. If not, contact your manufacturer or install an ATA/133 IDE controller card that supports 48-bit LBA mode. The options are "Disabled" or "**Auto**".

### **Block (Multi-Sector Transfer)**

Block mode boosts IDE drive performance by increasing the amount of data transferred. Only 512 bytes of data can be transferred per interrupt if block mode is not used. Block mode allows transfers of up to 64 KB per interrupt. Select "Disabled" to allow the data to be transferred from and to the device one sector at a time. Select "Auto" to allow the data transfer from and to the device occur multiple sectors at a time if the device supports it. The options are "**Auto**" and "Disabled".

### **PIO Mode**

IDE PIO (Programmable I/O) mode programs timing cycles between the IDE drive and the programmable IDE controller. As the PIO mode increases, the cycle time decreases. The options are "**Auto**", "0", "1", "2", "3", and "4". Select Auto to allow the BIOS to auto detect the PIO mode. Use this value if the IDE disk drive support cannot be determined. Select 0 to allow the BIOS to use PIO mode 0. It has a data transfer rate of 3.3 MBs. Select 1 to allow the BIOS to use PIO mode 1. It has a data transfer rate of 5.2 MBs. Select 2 to allow the BIOS to use PIO mode 2. It has a data transfer rate of 8.3 MBs. Select 3 to allow the BIOS to use PIO mode 3. It has a data transfer rate of 11.1 MBs. Select 4 to allow the BIOS to use PIO mode 4. It has a data transfer rate of 16.6 MBs. This setting generally works with all hard disk drives manufactured after 1999. For other disk drives, such as IDE CD-ROM drives, check the specifications of the drive.

### **DMA Mode**

Select Auto to allow the BIOS to auto detect the DMA mode. Use this value if the IDE disk drive support cannot be determined. Select SWDMA0 to allow the BIOS to use Single Word DMA mode 0. It has a data transfer rate of 2.1 MBs. Select SWDMA1 to allow the BIOS to use Single Word DMA mode 1. It has a data transfer rate of 4.2 MBs. Select SWDMA2 to allow the BIOS to use Single Word DMA mode 2. It has a data transfer rate of 8.3 MBs. Select MWDMA0 to allow the BIOS to use Multi Word DMA mode 0. It has a data transfer rate of 4.2 MBs. Select MWDMA1 to allow the BIOS to use Multi Word DMA mode 1. It has a data transfer rate of 13.3 MBs. Select MWDMA2 to allow the BIOS to use Multi-Word DMA mode 2. It has a data transfer rate of 16.6 MBs. Select UDMA0 to allow the BIOS to use Ultra DMA mode 0. It has a data transfer rate of 16.6 MBs. It has the same transfer rate as PIO mode 4 and Multi Word DMA mode 2. Select UDMA1 to allow the BIOS to use Ultra DMA mode 1. It has a data transfer rate of 25 MBs. Select UDMA2 to allow the BIOS to use Ultra DMA mode 2. It has a data transfer rate of 33.3 MBs.

The Options are "**Auto**", "SWDMA0", "SWDMA1", "SWDMA2", "MWDMA0", "MWDMA1", "MWDMA2", "UDMA0", "UDMA1", and "UDMA2".

### S.M.A.R.T. For Hard disk drives

Self-Monitoring Analysis and Reporting Technology (SMART) can help predict impending drive failures. Select "Auto" to allow BIOS to auto detect hard disk drive support. Select "Disabled" to prevent the BIOS from using the S.M.A.R.T. Select "Enabled" to allow the BIOS to use the S.M.A.R.T. to support hard drive disk. The options are "Disabled", "Enabled", and "**Auto.**"

### 32Bit Data Transfer

Select "Enabled" to activate the function of 32-Bit data transfer. Select "Disabled" to deactivate the function. The options are "Enabled" and "**Disabled**".

### System Memory

When AMI BIOS auto detects the System Memory, it will automatically display the size of the memory.

## 4-3 Advanced BIOS Setup

The Advanced BIOS Setup screen is shown below. The sub menus are described on the following pages.

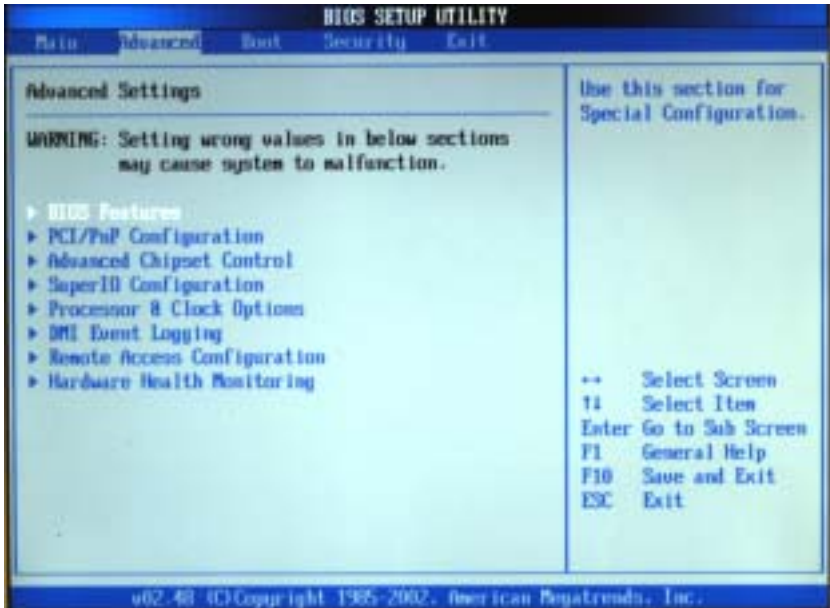

## ► BIOS Features

### ► Boot Settings Configuration

This item allows the user to configure the system's boot settings.



#### Quick Boot

The default setting is "**Enabled**". Select "Disabled" to allow the BIOS to perform all POST tests. Select "Enabled" to allow the BIOS to skip certain POST tests to reduce the time needed for the system to boot up.

#### Quiet Boot

Set this value to allow the boot up screen options to be modified between POST messages or OEM logo. The default setting is **Enabled**. Select Disabled to allow the computer system to display the POST messages. Select Enabled to allow the computer system to display the OEM logo.

#### Add-On ROM Display Mode

Set this option to display add-on ROM (read-only memory) messages. The default setting is **Force BIOS**. Select "Force BIOS" to allow the computer system to force a third party BIOS to display during system boot. Select "Keep Current" to allow the computer system to display the BIOS information during system boot. The options are "Force BIOS" and "Keep Current".

### **Bootup Num-Lock**

Set this value to allow the Number Lock setting to be modified during boot up. The default setting is **"On."** The options are "On" and "Off".

### **PS/2 Mouse Support**

Set this value to allow the PS/2 mouse support to be modified. The default setting is **Enabled.** The options are "Enabled" and "Disabled".

### **Wait for 'F1' If Error**

Select Enable to activate the function of Wait for "F1" if Error. The options are **"Enabled"** and "Disabled".

### **Hit 'DEL' Message Display**

Select "Enabled" to display Setup Message when the user hits the DEL key. The options are **"Enabled"** and "Disabled".

### **Interrupt 19 Capture**

Select "Enabled" to allow ROMs to trap Interrupt 19. The options are "Enabled" and **"Disabled."**

## **▶ACPI Configuration**

This item allows the user to enable or disable ACPI support for the operating system.

### **ACPI Aware O/S**

Select "Yes" if the operating system supports ACPI. Select "No" if the operating system does not support ACPI. The options are "No" and **"Yes."**

## **▶Advanced ACPI Configuration**

### **ACPI 2.0 Features**

Select "Yes" to allow RSDP pointers to point to the 64-bit Fixed System Description Tables. Select "No" to deactivate this function. The options are "Yes" and **"No."**

### **ACPI APIC Support**

Select "Enabled" to allow the ACPI APIC Table Pointer to be included in the RSDP pointer list. The options are "**Enabled**", and "Disabled".

### **AMI OEMB Table**

Select "Enabled" to allow the OEMB Table Pointer to be included in the R(x)SDT pointer lists. The options are "**Enabled**", and "Disabled".

### **Headless Mode**

Select "Enabled" to activate the Headless Operation Mode through ACPI. The options are "Enabled", and "**Disabled**".

### **Power Button Instant Off**

Select "Enabled" to activate the function of "Power Button Instant off". The options are "**Enabled**", and "Disabled".

### **Power Lost Control**

Select "Stay Off" if you want the system to remain off when the power recovers from an outage. Select "Power On" if you want the system to be automatically turned on when the power recovers from an outage. Select "Last State" if you want to system to resume its last state when the power recovers from an outage. The options are "Stay Off", "Power On" and "**Last State**".

### **PXE Option ROM**

This feature allows the user to disable or enable the PXE Option ROM. The options are "**Enabled**" and "Disabled".

### **Wake On LAN from S5**

Select "Enabled" to allow the BIOS to Wake Up LAN from S5. The options are "**Enabled**", and "Disabled".

### **Wake On Ring from S5**

Select "Enabled" to activate the function of "Wake On Ring from S5". The options are "**Enabled**", and "Disabled".

### **Watch Dog Timer**

Select "Enabled" to activate Watch Dog Timer. The options are "**Enabled**" or "Disabled".

## Keyboard Clock Setting

Select "Enabled" to allow the user set the keyboard clock Setting. The options are "Enabled", and "**Disabled**".

## ►System Frequency Display

This feature allows the BIOS to display the status, and the frequency of Front Side Bus, Memory and PCI slots.

## ►PCI/PnP Configuration

### Plug & Play O/S

Select "Yes" to allow the operating system to configure Plug & Play devices that are not required when booting up the system, if the function of Plug & Play is supported by the OS. Select "No" to allow the BIOS to configure Plug & Play devices when the system is booting up. The options are "Yes", and "**No**".

## PCI Latency Timer

This option sets the latency of all PCI devices on the PCI bus. The default setting is "64." Select "32" to set the PCI latency to 32 PCI clock cycles. Select "64" to set the PCI latency to 64 PCI clock cycles. Select "96" to set the PCI latency to 96 PCI clock cycles. Select "128" to set the PCI latency to 128 PCI clock cycles. Select "160" to set the PCI latency to 160 PCI clock cycles. Select "192" to set the PCI latency to 192 PCI clock cycles. Select "224" to set the PCI latency to 224 PCI clock cycles. Select "248" to set the PCI latency to 248 PCI clock cycles.

## Allocate IRQ to PCI VGA

Set this value to allow or restrict the system from giving the VGA adapter card an interrupt address. The options are "**Yes**" and "No".

## Palette Snooping

Set this value to allow the system to modify the Palette Snooping settings. The default setting is "Disabled". This setting should not be changed unless the VGA card manufacturer indicates otherwise. Select "Enabled" to inform the PCI devices that an ISA based Graphics device is installed in the system so that the ISA based Graphics card will function correctly. Always check with your adapter card's manuals first, before modifying the default settings in the BIOS. The options are "Enabled" and "**Disabled**".

### PCI IDE BusMaster

Set this value to allow or prevent the use of PCI IDE busmastering. Select "Enabled" to allow the BIOS to use PCI busmaster for reading and writing to IDE drives. The options are "**Disabled**" and "Enabled".

### OffBoard PCI/ISA IDE Card

Set this value to allow the OffBoard PCI/ISA IDE Card to be selected. Select "Auto" to allow the BIOS to automatically select the location of an OffBoard PCI IDE adapter card. Select "PCI Slot1" only when there is an IDE adapter card installed in PCI Slot 1. Select "PCI Slot2" only when there is an IDE adapter card installed in PCI Slot 2. Select "PCI Slot 3" only when there is an IDE adapter card installed in PCI Slot 3. Select "PCI Slot 4" only if there is an IDE adapter card installed in PCI Slot 4. The default setting is "**Auto**".

### IRQ

Set this value to allow the IRQ settings to be modified. The default setting is "**Available**". Select "Available" to allow the specified IRQ to be used by a PCI/PnP device. The options are "**Available**" and "Reserved" for the following IRQs. Select "Reserved" to allow the specified IRQ to be used by a legacy ISA device.

IRQ3

IRQ4

IRQ5

IRQ7

IRQ9

IRQ10

IRQ11

IRQ14

IRQ15

## DMA

Select "Available" to allow the specified DMA to be used by PCI/PnP device. Select "Reserved" to allow the specified DMA to be used by a legacy ISA device. The options are "**Available**" and "Reserved".

DMA Channel 0

DMA Channel 1

DMA Channel 3

DMA Channel 5

DMA Channel 6

DMA Channel 7

## Reserved Memory Size

This item allows the system to reserve memory that is used by ISA devices. Select "Disabled" to prevent BIOS from reserving memory to ISA devices. Select "16K" to allow the system to reserve 16K of the system memory for the ISA devices. Select "32K" to allow the system to reserve 32K of the system memory for the ISA devices. Select "64K" to allow the system for reserve 64K of the system memory to the ISA devices. The default setting is "**Disabled**".

## ►Advanced Chipset Control

### ►Intel E7500/7501 NorthBridge Configuration

This feature allows the user to configure the settings for Intel E7500/E7501 NorthBridge chipset.

#### Chipset Memory Remap Feature

Select "Enabled" to allow remapping of overlapped PCI memory above the total physical memory. The options are "**Enabled**" and "Disabled."

#### Memory Hole

Select "Enabled" to allow the memory hole to be set from 15M to 16M. The options are "**Disabled**" and "enabled."

## ► Intel ICH3 SouthBridge Configuration

This feature allows the user to configure the settings for Intel ICH3 SouthBridge chipset.

### ICH3 Dev31 Func1, IDE

Select "Enabled" to enable the ICH3 IDE Controller. The options are "**Enabled**" and "Disabled."

### ICH3 Dev31 Func3, SMBUS

Select "Enabled" to enable the ICH3 SMBUS Controller. The options are "**Enabled**" and "Disabled."

### ICH3 Dev29 Func0, USB#1

Select "Enabled" to enable the ICH3 USB Host Controller#1. The options are "**Enabled**" and "Disabled."

### ICH3 Dev29 Func1, USB#2

Select "Enabled" to enable the ICH3 USB Host Controller#2. The options are "**Disabled**" and "Enabled."

### ICH3 Dev29 Func2, USB#3

Select "Enabled" to enable the ICH3 USB Host Controller#3. The options are "**Disabled**" and "Enabled."

### ICH3 Positive Decode

Select "Enabled" to activate the function of Positive Decode in ICH3. Select "Enabled" only when the optional Onboard PCI/ISA Bridge is present. The options are "**Disabled**" and "Enabled."

### IOAPIC

Select "Enabled" to enable IOAPIC in ICH3. The options are "**Enabled**" and "Disabled."

### Extended IOAPIC

Select "Enabled" to enable the extended mode of IOAPIC in ICH3. The options are "**Enabled**" and "Disabled."

### CPU B.I.S.T.

Select "Enabled" to enable the function of CPU Built In Self Test. The options are "**Enabled**" and "Disabled."

### **ICH3 DMA Collection**

Select "Enabled" to enable the DMA Collection buffer. The options are "**Enabled**" and "Disabled."

### **DMA Type**

Select the type of DMA performed on this channel. The options are "**LPC DMA**" and "PC/PCI".

DMA-0 Type

DMA-1 Type

DMA-2 Type

DMA-3 Type

DMA-5 Type

DMA-6 Type

DMA-7 Type

### **► Intel PCI-64 Hub 2 Configuration**

This feature allows the user to configure the settings for Intel PCI-64 Hub2 PCIHub chipset.

### **HotPlug Inhibit Bus Connect**

Select "Enabled" to enable the function of "Inhibit Bus Connect Status" in HotPlug Controller. The options are "**Enabled**" and "Disabled."

### **PCI Slot1 & Slot2 Frequency**

This feature allows the user to set the maximum PCI bus speed to be programmed. When set to "Auto", the bus speed will be decided based on the capabilities of the device on that particular bus. The options are "**Auto**", "33 MHz", "66 MHz", "100 MHz", and "133 MHz".

## ► USB Configuration

This feature allows the user to configure USB settings.

### Legacy USB Support

Select "Enabled" to enable the support for USB Legacy. The options are "Disabled", and "**Enabled**."

## ► USB Mass Storage Device Configuration

This feature allows the user to configure USB Mass Storage Device settings.

### USB Mass Storage Reset Delay

This feature allows the user to set the reset delay for USB Mass Storage. The options are "**10 Sec**", "20 Sec", "30 Sec" and "40 Sec".

## ► Super IO Configuration

### OnBoard Floppy Controller

Select "Enabled" to enable the Onboard Floppy Controller. The options are "Disabled", and "**Enabled**."

### Serial Port1 Address

This option specifies the base I/O port address and Interrupt Request address of serial port 1. Select "Disabled" to prevent the serial port from accessing any system resources. When this option is set to *Disabled*, the serial port physically becomes unavailable. Select "3F8/IRQ4" to allow the serial port to use 3F8 as its I/O port address and IRQ 4 for the interrupt address. The options are "Disabled", "**3F8/IRQ4**", "3E8/IRQ4", "2E8/IRQ3".

### Serial Port2 Address

This option specifies the base I/O port address and Interrupt Request address of serial port 2. Select "Disabled" to prevent the serial port from accessing any system resources. When this option is set to "Disabled", the serial port physically becomes unavailable. Select "2F8/IRQ3" to allow the serial port to use 2F8 as its I/O port address and IRQ 3 for the interrupt address. The options are "Disabled", "**2F8/IRQ3**", "3E8/IRQ4", "2E8/IRQ3".

### Serial Port2 Mode

This feature sets Serial Port2 Mode. The options are "Normal", "IrDA", and "ASK IR". The default setting is "**Normal**".

### **Parallel Port Address**

This option specifies the I/O address used by the parallel port. Select "Disabled" to prevent the parallel port from accessing any system resources. When the value of this option is set to "Disabled", the printer port becomes unavailable. Select "378" to allow the parallel port to use 378 as its I/O port address. The majority of parallel ports on computer systems use IRQ7 and I/O Port 378H as the standard setting. Select "278" to allow the parallel port to use 278 as its I/O port address. Select "3BC" to allow the parallel port to use 3BC as its I/O port address. The default setting is "**378**."

### **Parallel Port Mode**

This feature sets Parallel Port Mode. The options are "Normal", "Bi-Directional", "EPP" and "ECP". The default setting is "**Normal**".

### **Parallel Port IRQ**

This feature sets Parallel Port IRQ. The options are "IRQ 5" and "IRQ 7". The default setting is "**IRQ 7**".

## ►Processor & Clock Options

### Hyper Threading

Select "Enabled" to enable the function of Hyper Threading for HT supported processor(s). The Options are "**Enabled**" or "Disabled."

### Ratio CMOS Setting

This feature allows the user to set the ratio between CPU Core Clock and the FSB Frequency. The default setting is "8".

### Spread Spectrum

Select "Enabled" to activate the function of "Spread Spectrum" in order to reduce the possibility of Electromagnetic Interference. The options are "Enabled" and "**Disabled**."

## ►DMI Event Logging

### View Event Log

Highlight this item and press <Enter> to view the contents of the event log.

### Mark All Events as Read

Highlight this item and press <Enter> to mark the DMI events as read.

### Clear Event Logs

This setting will clear all event logs when set to "OK". Options are "OK" and "**Cancel**".

### Event Log Statistics

This setting allows you to view Event Log Statistics.

## ►Remote Access Configuration

You can use this screen to select options for the Remote Access Configuration. Use the up and down <Arrow> keys to select an item. Use the <Plus> and <Minus> keys to change the value of the selected option.

### Remote Access

This feature allows the user to disable the function of Remote Access. If "Disabled" is not select, then you can select a Remote Access type. The options are "Disabled" or "**Serial**".

### Serial Port Number

Select the serial port you want to use for console redirection. You can set the value for this option to either "**COM1**" or "COM2".

## Serial Port Mode

Select the baud rate you want the serial port to use for console redirection. Select "115200 8,n,1" to select 115200 as the baud rate (transmitted bits per second) of the serial port. Select "57600 8,n,1" to set 57600 as the baud rate (transmitted bits per second) of the serial port. Select "19200 8,n,1" to set 19200 as the baud rate (transmitted bits per second) of the serial port. The default setting is "**115200 8,n,1**".

## Flow Control

Select the flow control for console redirection. You can set the value for this option to either "**None**" or "Hardware".

## Terminal Type

This feature allows you to select the target terminal type. You can set the value for this option to either "**ANSI**" or "VT100".

## Send Carriage Return

Select "Enabled" if the target terminal type has more than 80 columns or does not have the function of "Word Wrap". The options are "Enabled" and "**Disabled**".

## Redirection After BIOS POST

Select "Disabled" to turn off the function of Console Redirection after POST. Select "Boot Loader" to keep the function of Redirection active during POST and during Boot Load. Select "Always" to keep the function of "Redirection" active all the time. If "Always" is selected, some operating systems might not function well. The default setting is "**Boot Loader**".

## ► Hardware Health Monitoring

### H/W Health Function

Select "Enabled" to enable the function of Hardware Health Monitoring Device. The Options are "**Enabled**" and "Disabled".

### Overheat Temperature Trips

The feature allows the user to set the CPU temperature threshold. The options are "72°C", "**78°C**" and "85°C".

### Hardware Health Event Monitoring

The feature allows the BIOS to display the status of Hardware Health Event Monitoring. Items displayed include: the temperatures of CPUs, the speed of system fans and Processor Vcore.

## 4-4 Boot Settings

### Boot Settings Configuration

Use this screen to select options for the Boot Settings Configuration. The settings are described on the following pages. The screen is shown below.



#### ► Boot Device Priority

This feature allows the user to specify the sequence of priority for the Boot Device.

The settings are "1st Floppy Drive", "CD ROM", "ATAPI CDROM", and "Disabled." The default settings are:

- 1st boot device – 1st Floppy Drive
- 2nd boot device – CD ROM
- 3rd boot device – ATAPI CDROM
- 4th boot device – IBA 1.0.15 Slot 04

#### ► Hard Disk Drives

This feature allows the user to specify the Boot sequence from available Hard Drives.

### **1st Drive**

Specify the boot sequence for 1st Hard Drive. The Options are "**PM-ST340016A**" and "Disabled".

### **►Removable Drives**

This feature allows the user to specify the Boot sequence from available Removable Drives.

#### **1st Drive**

Specify the boot sequence for 1st Removable Drive. The Options are "**1st Floppy Drive**" and "Disabled".

### **►ATAPI Drives**

This feature allows the user to specify the boot sequence from available ATAPI CDROM Drives.

#### **1st Drive**

Specify the boot sequence for 1st Hard Drive. The Options are "**CD ROM**" and "Disabled".

## 4-5 Security Settings

AMI BIOS provides a Supervisor and a User password. If you use both passwords, the Supervisor password must be set first.

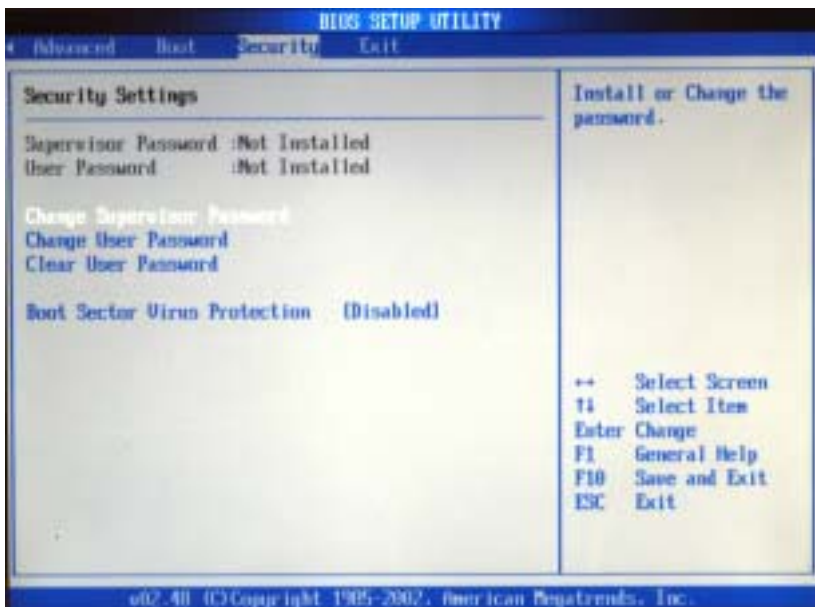

### Change Supervisor Password

Select this option and press <Enter> to access the sub menu, and then, type in the password.

### Change User Password

Select this option and press <Enter> to access the sub menu, and then, type in the password.

### Clear User Password

Select this option and press <Enter> to access the sub menu. You can use the sub menu to clear the user password.

### Boot Sector Virus Protection

This option is near the bottom of the Security Setup screen. Select "Disabled" to deactivate the Boot Sector Virus Protection. Select "Enabled" to enable boot sector protection. When "Enabled", AMI BIOS displays a warning when any program (or virus) issues a Disk Format command or attempts to write to the boot sector of the hard disk drive. The options are "Enabled" and "Disabled".

## 4-6 Exit Options

Select the Exit tab from the BIOS Setup Utility screen to enter the Exit BIOS Setup screen.

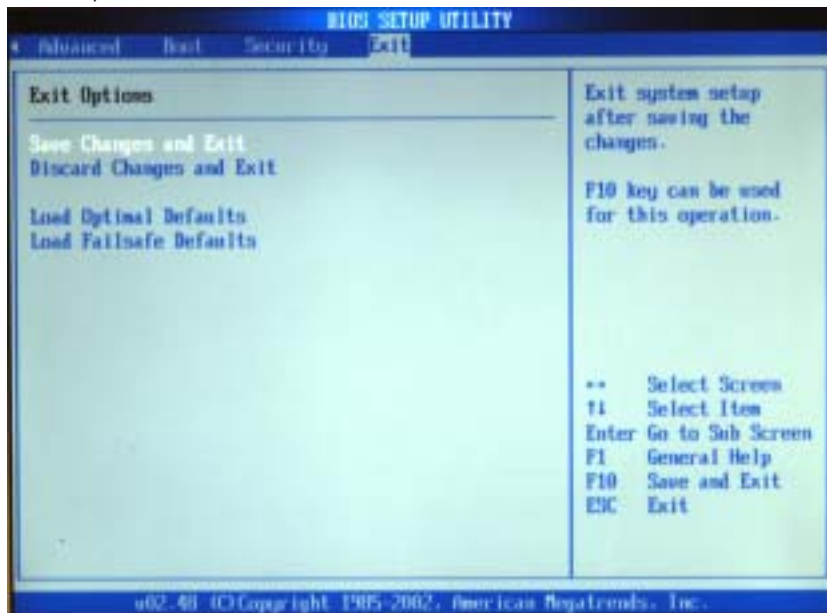

### Save Changes and Exit

When you have completed the system configuration changes, select this option to leave BIOS Setup and reboot the computer, so the new system configuration parameters can take effect. Select Save Changes and Exit from the Exit menu and press <Enter>.

### Discard Changes and Exit

Select this option to quit BIOS Setup without making any permanent changes to the system configuration and reboot the computer. Select Discard Changes and Exit from the Exit menu and press <Enter>.

### Discard Changes

Select this option to discard any changes done so far to any of BIOS Setup. Select Discard Changes from the Exit menu and press <Enter>.

### **Load Optimal Defaults**

To set this feature, select Load Optimal Defaults from the Exit menu and press <Enter>. Then, Select "OK" to allow BIOS to automatically load Optimal Defaults to BIOS Settings. The Optimal settings are designed for maximum system performance, but may not work best for all computer applications.

### **Load Fail-Safe Defaults**

To set this feature, select Load Fail-Safe Defaults from the Exit menu and press <Enter>. The Fail-Safe settings are designed for maximum system stability, but not maximum performance.

## Appendix A

# BIOS Error Beep Codes

During the POST (Power-On Self-Test) routines, which are performed each time the system is powered on, errors may occur.

**Non-fatal errors** are those which, in most cases, allow the system to continue the boot-up process. The error messages normally appear on the screen.

**Fatal errors** are those which will not allow the system to continue the boot-up procedure. If a fatal error occurs, you should consult with your system manufacturer for possible repairs.

These fatal errors are usually communicated through a series of audible beeps. The numbers on the fatal error list, on the following page, correspond to the number of beeps for the corresponding error. All errors listed, with the exception of Beep Code 8, are fatal errors.

POST codes may be read on the debug LEDs located beside the LAN port on the motherboard backplane. See the description of the Debug LEDs (LED1 and LED2) in Section 2-6.

### A-1 AMIBIOS Error Beep Codes

Beep Code	Error Message	Description
1 beep	Refresh	Circuits have been reset. (Ready to power up.)
5 short, 1 long	Memory error	No memory detected in system
8 beeps	Display memory read/write error	Video adapter missing or with faulty memory

**Notes**

## Appendix B

# BIOS POST Checkpoint Codes

When AMIBIOS performs the Power On Self Test, it writes checkpoint codes to I/O port 0080h. If the computer cannot complete the boot process, diagnostic equipment can be attached to the computer to read I/O port 0080h.

### B-1 Uncompressed Initialization Codes

The uncompressed initialization checkpoint codes are listed in order of execution:

<b>Checkpoint</b>	<b>Code</b>	<b>Description</b>
D0h		The NMI is disabled. Power on delay is starting. Next, the initialization code checksum will be verified.
D1h		Initializing the DMA controller, performing the keyboard controller BAT test, starting memory refresh, and entering 4 GB flat mode next.
D3h		Starting memory sizing next.
D4h		Returning to real mode. Executing any OEM patches and setting the Stack next.
D5h		Passing control to the uncompressed code in shadow RAM at E000:0000h. The initialization code is copied to segment 0 and control will be transferred to segment 0.
D6h		Control is in segment 0. Next, checking if <Ctrl> <Home> was pressed and verifying the system BIOS checksum. If either <Ctrl> <Home> was pressed or the system BIOS checksum is bad, next will go to checkpoint code E0h. Otherwise, going to checkpoint code D7h.

## B-2 Bootblock Recovery Codes

The bootblock recovery checkpoint codes are listed in order of execution:

<b>Checkpoint</b>	<b>Code</b>	<b>Description</b>
E0h		The onboard floppy controller if available is initialized. Next, beginning the base 512 KB memory test.
E1h		Initializing the interrupt vector table next.
E2h		Initializing the DMA and Interrupt controllers next.
E6h		Enabling the floppy drive controller and Timer IRQs. Enabling internal cache memory.
Edh		Initializing the floppy drive.
Eeh		Looking for a floppy diskette in drive A:. Reading the first sector of the diskette.
Efh		A read error occurred while reading the floppy drive in drive A:.
F0h		Next, searching for the AMIBOOT.ROM file in the root directory.
F1h		The AMIBOOT.ROM file is not in the root directory.
F2h		Next, reading and analyzing the floppy diskette FAT to find the clusters occupied by the AMIBOOT.ROM file.
F3h		Next, reading the AMIBOOT.ROM file, cluster by cluster.
F4h		The AMIBOOT.ROM file is not the correct size.
F5h		Next, disabling internal cache memory.
FBh		Next, detecting the type of flash ROM.
FCh		Next, erasing the flash ROM.
FDh		Next, programming the flash ROM.
FFh		Flash ROM programming was successful. Next, restarting the system BIOS.

## B-3 Uncompressed Initialization Codes

The following runtime checkpoint codes are listed in order of execution.

These codes are uncompressed in F0000h shadow RAM.

<b>Checkpoint</b>	<b>Code</b>	<b>Description</b>
03h		The NMI is disabled. Next, checking for a soft reset or a power on condition.
05h		The BIOS stack has been built. Next, disabling cache memory.
06h		Uncompressing the POST code next.
07h		Next, initializing the CPU and the CPU data area.
08h		The CMOS checksum calculation is done next.
0Ah		The CMOS checksum calculation is done. Initializing the CMOS status register for date and time next.
0Bh		The CMOS status register is initialized. Next, performing any required

---

---

	initialization before the keyboard BAT command is issued.
0Ch	The keyboard controller input buffer is free. Next, issuing the BAT command to the keyboard controller.
0Eh	The keyboard controller BAT command result has been verified. Next, performing any necessary initialization after the keyboard controller BAT command test.
0Fh	The initialization after the keyboard controller BAT command test is done. The keyboard command byte is written next.
10h	The keyboard controller command byte is written. Next, issuing the Pin 23 and 24 blocking and unblocking command.
11h	Next, checking if <End or <Ins> keys were pressed during power on. Initializing CMOS RAM if the <i>Initialize CMOS RAM in every boot</i> AMIBIOS POST option was set in AMIBCP or the <End> key was pressed.
12h	Next, disabling DMA controllers 1 and 2 and interrupt controllers 1 and 2.
13h	The video display has been disabled. Port B has been initialized. Next, initializing the chipset.
14h	The 8254 timer test will begin next.
19h	The 8254 timer test is over. Starting the memory refresh test next.
1Ah	The memory refresh line is toggling. Checking the 15 second on/off time next.
2Bh	Passing control to the video ROM to perform any required configuration before the video ROM test.
2Ch	All necessary processing before passing control to the video ROM is done. Looking for the video ROM next and passing control to it.
2Dh	The video ROM has returned control to BIOS POST. Performing any required processing after the video ROM had control.
23h	Reading the 8042 input port and disabling the MEGAKEY Green PC feature next. Making the BIOS code segment writable and performing any necessary configuration before initializing the interrupt vectors.
24h	The configuration required before interrupt vector initialization has completed. Interrupt vector initialization is about to begin.

---

<b>Checkpoint</b>	<b>Code</b>	<b>Description</b>
25h		Interrupt vector initialization is done. Clearing the password if the POST DIAG switch is on.
27h		Any initialization before setting video mode will be done next.
28h		Initialization before setting the video mode is complete. Configuring the monochrome mode and color mode settings next.
2Ah		Bus initialization system, static, output devices will be done next, if present. See the last page for additional information.
2Eh		Completed post-video ROM test processing. If the EGA/VGA controller is not found, performing the display memory read/write test next.
2Fh		The EGA/VGA controller was not found. The display memory read/write test is about to begin.
30h		The display memory read/write test passed. Look for retrace checking next.
31h		The display memory read/write test or retrace checking failed. Performing the alternate display memory read/write test next.
32h		The alternate display memory read/write test passed. Looking for alternate display retrace checking next.
34h		Video display checking is over. Setting the display mode next.
37h		The display mode is set. Displaying the power on message next.
38h		Initializing the bus input, IPL, general devices next, if present. See the last page of this chapter for additional information.
39h		Displaying bus initialization error messages. See the last page of this chapter for additional information.
3Ah		The new cursor position has been read and saved. Displaying the <i>Hit &lt;DEL&gt;</i> message next.
3Bh		The <i>Hit &lt;DEL&gt;</i> message is displayed. The protected mode memory test is about to start.
40h		Preparing the descriptor tables next.
42h		The descriptor tables are prepared. Entering protected mode for the memory test next.
43h		Entered protected mode. Enabling interrupts for diagnostics mode next.
44h		Interrupts enabled if the diagnostics switch is on. Initializing data to check memory wraparound at 0:0 next.
45h		Data initialized. Checking for memory wraparound at 0:0 and finding the total system memory size next.
46h		The memory wraparound test is done. Memory size calculation has been done. Writing patterns to test memory next.
47h		The memory pattern has been written to extended memory. Writing patterns to the base 640 KB memory next.

---

<b>Checkpoint</b>	<b>Code</b>	<b>Description</b>
48h		Patterns written in base memory. Determining the amount of memory below 1 MB next.
49h		The amount of memory below 1 MB has been found and verified. Determining the amount of memory above 1 MB memory next.
4Bh		The amount of memory above 1 MB has been found and verified. Checking for a soft reset and clearing the memory below 1 MB for the soft reset next. If this is a power on situation, going to checkpoint 4Eh next.
4Ch		The memory below 1 MB has been cleared via a soft reset. Clearing the memory above 1 MB next.
4Dh		The memory above 1 MB has been cleared via a soft reset. Saving the memory size next. Going to checkpoint 52h next.
4Eh		The memory test started, but not as the result of a soft reset. Displaying the first 64 KB memory size next.
4Fh		The memory size display has started. The display is updated during the memory test. Performing the sequential and random memory test next.
50h		The memory below 1 MB has been tested and initialized. Adjusting the displayed memory size for relocation and shadowing next.
51h		The memory size display was adjusted for relocation and shadowing. Testing the memory above 1 MB next.
52h		The memory above 1 MB has been tested and initialized. Saving the memory size information next.
53h		The memory size information and the CPU registers are saved. Entering real mode next.
54h		Shutdown was successful. The CPU is in real mode. Disabling the Gate A20 line, parity, and the NMI next.
57h		The A20 address line, parity, and the NMI are disabled. Adjusting the memory size depending on relocation and shadowing next.
58h		The memory size was adjusted for relocation and shadowing. Clearing the <i>Hit &lt;DEL&gt;</i> message next.
59h		The <i>Hit &lt;DEL&gt;</i> message is cleared. The <i>&lt;WAIT...&gt;</i> message is displayed. Starting the DMA and interrupt controller test next.

---

<b>Checkpoint</b>	<b>Code</b>	<b>Description</b>
60h		The DMA page register test passed. Performing the DMA Controller 1 base register test next.
62h		The DMA controller 1 base register test passed. Performing the DMA controller 2 base register test next.
65h		The DMA controller 2 base register test passed. Programming DMA controllers 1 and 2 next.
66h		Completed programming DMA controllers 1 and 2. Initializing the 8259 interrupt controller next.
67h		Completed 8259 interrupt controller initialization.
7Fh		Extended NMI source enabling is in progress.
80h		The keyboard test has started. Clearing the output buffer and checking for stuck keys. Issuing the keyboard reset command next.
81h		A keyboard reset error or stuck key was found. Issuing the keyboard controller interface test command next.
82h		The keyboard controller interface test completed. Writing the command byte and initializing the circular buffer next.
83h		The command byte was written and global data initialization has completed. Checking for a locked key next.
84h		Locked key checking is over. Checking for a memory size mismatch with CMOS RAM data next.
85h		The memory size check is done. Displaying a soft error and checking for a password or bypassing WINBIOS Setup next.
86h		The password was checked. Performing any required programming before WINBIOS Setup next.
87h		The programming before WINBIOS Setup has completed. Uncompressing the WINBIOS Setup code and executing the AMIBIOS Setup or WINBIOS Setup utility next.
88h		Returned from WINBIOS Setup and cleared the screen. Performing any necessary programming after WINBIOS Setup next.
89h		The programming after WINBIOS Setup has completed. Displaying the power on screen message next.
8Bh		The first screen message has been displayed. The <WAIT...> message is displayed. Performing the PS/2 mouse check and extended BIOS data area allocation check next.
8Ch		Programming the WINBIOS Setup options next.
8Dh		The WINBIOS Setup options are programmed. Resetting the hard disk controller next.
8Fh		The hard disk controller has been reset. Configuring the floppy drive controller next.
91h		The floppy drive controller has been configured. Configuring the hard disk drive controller next.

---

<b>Checkpoint</b>	<b>Code</b>	<b>Description</b>
95h		Initializing the bus option ROMs from C800 next. See the last page of this chapter for additional information.
96h		Initializing before passing control to the adaptor ROM at C800.
97h		Initialization before the C800 adaptor ROM gains control has completed. The adaptor ROM check is next.
98h		The adaptor ROM had control and has now returned control to BIOS POST. Performing any required processing after the option ROM returned control.
99h		Any initialization required after the option ROM test has completed. Configuring the timer data area and printer base address next.
9Ah		Set the timer and printer base addresses. Setting the RS-232 base address next.
9Bh		Returned after setting the RS-232 base address. Performing any required initialization before the Coprocessor test next.
9Ch		Required initialization before the Coprocessor test is over. Initializing the Coprocessor next.
9Dh		Coprocessor initialized. Performing any required initialization after the Coprocessor test next.
9Eh		Initialization after the Coprocessor test is complete. Checking the extended keyboard, keyboard ID, and Num Lock key next. Issuing the keyboard ID command next.
A2h		Displaying any soft errors next.
A3h		The soft error display has completed. Setting the keyboard typematic rate next.
A4h		The keyboard typematic rate is set. Programming the memory wait states next.
A5h		Memory wait state programming is over. Clearing the screen and enabling parity and the NMI next.
A7h		NMI and parity enabled. Performing any initialization required before passing control to the adaptor ROM at E000 next.
A8h		Initialization before passing control to the adaptor ROM at E000h completed. Passing control to the adaptor ROM at E000h next.
A9h		Returned from adaptor ROM at E000h control. Performing any initialization required after the E000 option ROM had control next.
Aah		Initialization after E000 option ROM control has completed. Displaying the system configuration next.
Abh		Uncompressing the DMI data and executing DMI POST initialization next.
B0h		The system configuration is displayed.
B1h		Copying any code to specific areas.
00h		Code copying to specific areas is done. Passing control to INT 19h boot loader next.

---

**Notes**

## Appendix C

### Installing Software Programs and Drivers

#### C-1 Installing Windows Operating System

After all the hardware has been installed, you must first install the operating system, and then, other software drivers. The necessary drivers are all included on the Supermicro CDs that came packaged with your motherboard.



**Driver/Tool Installation Display Screen**

(\*Note: Click the icons showing a hand writing on paper to view the readme files for each item. Click the computer icons to the right of these items to install each item (from top to the bottom) one at a time. **After installing each item, you must re-boot the system before moving on to the next item on the list.** You should install everything here except for the SUPER Doctor utility, Intel LDCM and the LAN/SCSI driver diskettes, which are optional. The bottom icon with a CD on it allows you to view the entire contents of the CD. )

## C-2 Supero Doctor III

The Supero Doctor III program is a Web base management tool that supports remote management capability. It includes Remote and Local Management tools. The local management is called SD III Client. The Supero Doctor III program included on the CDROM that came with your motherboard allows you to monitor the environment and operations of your system. Supero Doctor III displays crucial system information such as CPU temperature, system voltages and fan status. See the Figure below for a display of the Supero Doctor III interface.

### Supero Doctor III Interface Display Screen-I (Health Information)



## Supero Doctor III Interface Display Screen-II (Remote Control)



(\*Note: SD III Software Revision 1.0 can be downloaded from our Website at: [ftp://ftp.supermicro.com/utility/Supero\\_Doctor\\_III/](ftp://ftp.supermicro.com/utility/Supero_Doctor_III/). You can also download SDIII User's Guide at: <http://www.supermicro.com/PRODUCT/Manuals/SDIII/UserGuide.pdf>. For Linux, we will still recommend Supero Doctor II.)

**Notes**