

SUPER[®]

SUPER[®] X6DA3-G2
SUPER[®] X6DAi-G2

USER'S MANUAL
Revision 1.0

The information in this User's Manual has been carefully reviewed and is believed to be accurate. The vendor assumes no responsibility for any inaccuracies that may be contained in this document, makes no commitment to update or to keep current the information in this manual, or to notify any person or organization of the updates.

Please Note: For the most up-to-date version of this manual, please see our web site at www.supermicro.com.

SUPERMICRO COMPUTER reserves the right to make changes to the product described in this manual at any time and without notice. This product, including software, if any, and documentation may not, in whole or in part, be copied, photocopied, reproduced, translated or reduced to any medium or machine without prior written consent.

IN NO EVENT WILL SUPERMICRO COMPUTER BE LIABLE FOR DIRECT, INDIRECT, SPECIAL, INCIDENTAL, OR CONSEQUENTIAL DAMAGES ARISING FROM THE USE OR INABILITY TO USE THIS PRODUCT OR DOCUMENTATION, EVEN IF ADVISED OF THE POSSIBILITY OF SUCH DAMAGES. IN PARTICULAR, THE VENDOR SHALL NOT HAVE LIABILITY FOR ANY HARDWARE, SOFTWARE, OR DATA STORED OR USED WITH THE PRODUCT, INCLUDING THE COSTS OF REPAIRING, REPLACING, INTEGRATING, INSTALLING OR RECOVERING SUCH HARDWARE, SOFTWARE, OR DATA.

Any disputes arising between manufacturer and customer shall be governed by the laws of Santa Clara County in the State of California, USA. The State of California, County of Santa Clara shall be the exclusive venue for the resolution of any such disputes. Supermicro's total liability for all claims will not exceed the price paid for the hardware product.

Unless you request and receive written permission from SUPER MICRO COMPUTER, you may not copy any part of this document.

Information in this document is subject to change without notice. Other products and companies referred to herein are trademarks or registered trademarks of their respective companies or mark holders.

Copyright © 2005 by SUPER MICRO COMPUTER INC.
All rights reserved.

Printed in the United States of America

Preface

About This Manual

This manual is written for system integrators, PC technicians and knowledgeable PC users. It provides information for the installation and use of the **SUPER** X6DA3-G2/X6DAi-G2 motherboard. The X6DA3-G2/X6DAi-G2 supports single or dual Intel® Xeon 64-bit processors at a 800 MHz front side bus. Based on Intel's Xeon EM64T Processor (800 MHz) and the E7525 chipset, the X6DA3-G2/X6DAi-G2 supports Intel's Hyper-Threading Technology (HT), the EM64T Technology, the Enhanced Intel SpeedStep Technology (EIST) and is ideal for high performance server environments with up to two processors on one system bus. The **SUPER** motherboard is intended to be professionally installed.

Manual Organization:

Chapter 1 describes the features, specifications and performance of the mainboard and provides detailed information about the chipset.

Chapter 2 provides hardware installation instructions. Read this chapter when installing the processor, memory modules and other hardware components into the system. If you encounter any problems, see **Chapter 3**, which describes troubleshooting procedures for the video, the memory and the system setup stored in CMOS.

Chapter 4 includes an introduction to BIOS and provides detailed information on running the CMOS Setup utility.

Appendix A provides BIOS POST Messages.

Appendix B lists BIOS POST Codes.

Appendix C lists Software Installation Instructions.

Conventions Used in the Manual:

Special attention should be given to the following symbols for proper installation and to prevent damage done to the components or injury to yourself:



Danger/Caution: Instructions to be strictly followed to prevent catastrophic system failure or to avoid bodily injury.



Warning: Important information given to ensure proper system installation or to prevent damage to the components.

(***Note**): **Note:** Additional Information given to differentiate various models or to ensure correct system setup.

Table of Contents

Preface

About This Manual	iii
Manual Organization	iii
Conventions Used in the Manual	iii

Chapter 1: Introduction

1-1 Overview	1-1
Checklist	1-1
Contacting Supermicro	1-2
SUPER [®] X6DA3-G2/X6DAi-G2 Image	1-3
SUPER [®] X6DA3-G2/X6DAi-G2 Layout	1-4
Quick Reference	1-5
Motherboard Features.....	1-6
Intel E7525 Chipset: System Block Diagram	1-8
1-2 Chipset Overview	1-9
1-3 Special Features	1-10
1-4 PC Health Monitoring	1-10
1-5 ACPI Features	1-11
1-6 Power Supply	1-12
1-7 Super I/O	1-12

Chapter 2: Installation

2-1 Static-Sensitive Devices	2-1
Precautions.....	2-1
Unpacking	2-1
2-2 Xeon Processor and Heatsink Installation	2-2
2-3 Installing DIMMs	2-6
2-4 Control Panel Connectors/I/O Ports.....	2-7
A. Back Panel Connectors/IO Ports	2-7
B. Front Control Panel	2-8
C. Front Control Panel Pin Definitions.....	2-9
NMI Button	2-9
Power LED	2-9
HDD LED	2-10
NIC1/NIC2 LED	2-10
OH/Fan Fail LED	2-11
Power Fail LED	2-11
Reset Button	2-12
Power Button	2-12

2-5	Connecting Cables	2-13
	ATX Power Connector	2-13
	Processor Power Connector	2-13
	Universal Serial Bus (USB).....	2-14
	Chassis Intrusion.....	2-14
	Fan Headers	2-15
	Keylock.....	2-15
	ATX PS/2 Keyboard and Mouse Ports.....	2-16
	Serial Ports	2-16
	Wake-On-Ring.....	2-17
	Wake-On-LAN	2-17
	GLAN (Ethernet Ports).....	2-18
	Power LED/Speaker Header (JD1)	2-18
	Power Fault	2-19
	Alarm Reset.....	2-19
	Overheat/Fan Fail LED	2-20
	SMB	2-20
	SMB PWR Connector	2-21
	SAS SMB PWR Connector	2-21
	AC'97 Audio & Audio Enable.....	2-22
	CD Connectors.....	2-22
	Audio Enable/Disable	2-22
2-6	Jumper Settings	2-23
	Explanation of Jumpers	2-23
	GLAN Enable/Disable	2-23
	CMOS Clear	2-24
	SAS Control Enable	2-24
	Watch Dog Enable	2-25
	3rd Power Supply Power Fault Detect.....	2-26
	Power Force On Enable.....	2-26
2-8	Onboard Indicators	2-27
	GLAN LEDs.....	2-27
	Backpanel SAS Activity LED Header.....	2-27
	Onboard SAS Activity LED Indicators.....	2-28
2-9	Parallel Port, Floppy/Hard Disk Drive, IPMI 2.0 and SAS Connections	2-29
	Parallel Port Connector	2-29

Floppy Connector	2-30
IPMI 2.0 Socket.....	2-30
IDE Connectors	2-31
SAS Connectors.....	2-32

Chapter 3: Troubleshooting

3-1 Troubleshooting Procedures	3-1
Before Power On.....	3-1
No Power.....	3-1
No Video	3-1
Memory Errors.....	3-2
Losing the System's Setup Configuration	3-2
3-2 Technical Support Procedures	3-2
3-3 Frequently Asked Questions	3-3
3-4 Returning Merchandise for Service	3-4

Chapter 4: BIOS

4-1 Introduction	4-1
4-2 Running Setup	4-2
4-3 Main BIOS Setup	4-2
4-4 Advanced Setup	4-7
4-5 Security Setup	4-19
4-6 Boot Setup.....	4-21
4-7 Exit.....	4-22

Appendices:

Appendix A: BIOS POST Error Messages.....	A-1
Appendix B: BIOS POST Codes.....	B-1
Appendix C: Installing Software Drivers and the Operating System	C-1

Chapter 1

Introduction

1-1 Overview

Checklist

Congratulations on purchasing your computer motherboard from an acknowledged leader in the industry. Supermicro boards are designed with the utmost attention to detail to provide you with the highest standards in quality and performance. Check that the following items have all been included with your motherboard. If anything listed here is damaged or missing, contact your retailer. All included with Retail Box.

One (1) Supermicro Mainboard

One (1) ribbon cable for IDE devices (CBL-036)

One (1) floppy ribbon cable (CBL-022)

Two (2) SAS cables (CBL-097) (*For the X6DA3-G2 only)

One (1) I/O backpanel shield (CSE-PT-53)

One (1) Supermicro CD containing drivers and utilities (CDR-x6)

One (1) User's/BIOS Manual

Two (2) CPU Mounting Brackets (SKT-0158) (pre-installed)

Contacting Supermicro

Headquarters

Address: SuperMicro Computer, Inc.
980 Rock Ave.
San Jose, CA 95131 U.S.A.

Tel: +1 (408) 503-8000
Fax: +1 (408) 503-8008
Email: marketing@supermicro.com (General Information)
support@supermicro.com (Technical Support)
Web Site: www.supermicro.com

Europe

Address: SuperMicro Computer B.V.
Het Sterrenbeeld 28, 5215 ML
's-Hertogenbosch, The Netherlands

Tel: +31 (0) 73-6400390
Fax: +31 (0) 73-6416525
Email: sales@supermicro.nl (General Information)
support@supermicro.nl (Technical Support)
rma@supermicro.nl (Customer Support)

Asia-Pacific

Address: SuperMicro, Taiwan
4F, No. 232-1 Liancheng Road
Chung-Ho 235, Taipei County, Taiwan, R.O.C.

Tel: +886-(2) 8226-3990
Fax: +886-(2) 8226-3991
Web Site: www.supermicro.com.tw

Technical Support:
Email: support@supermicro.com.tw
Tel: 886-2-8228-1366, ext.132 or 139

Figure 1-1. SUPER[®] X6DA3-G2/X6DAi-G2 Image

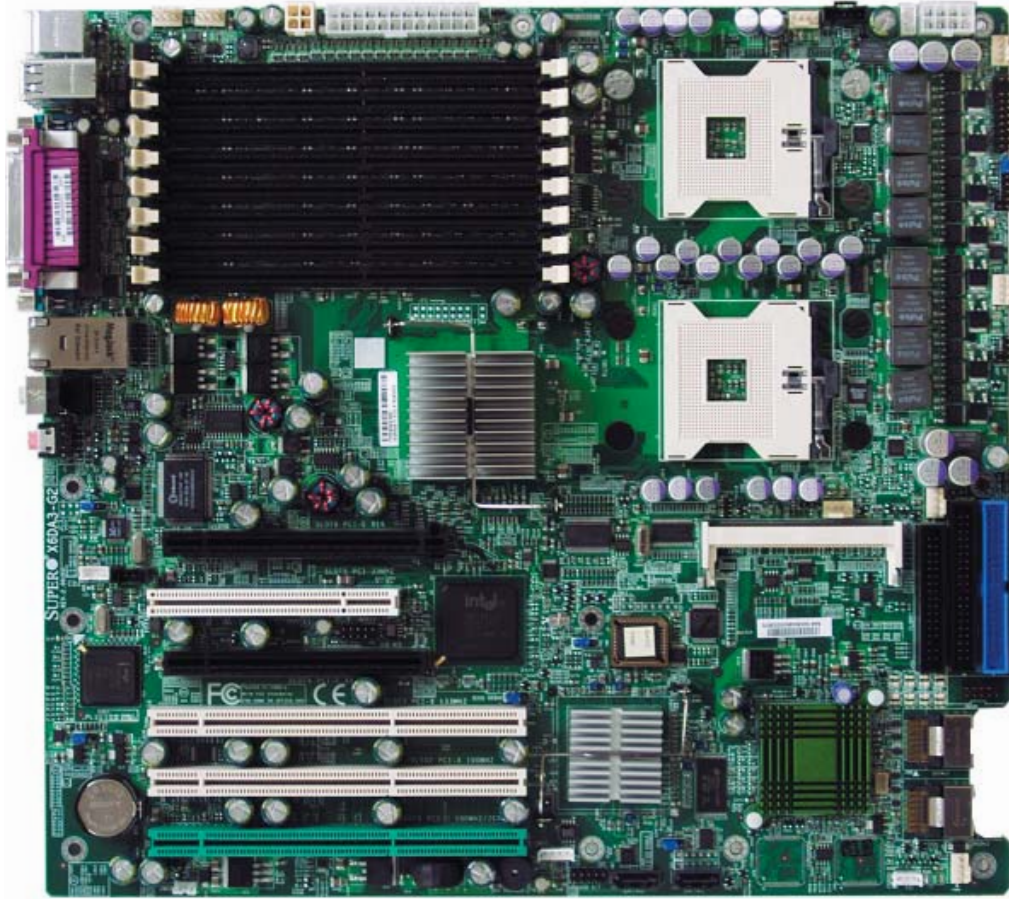
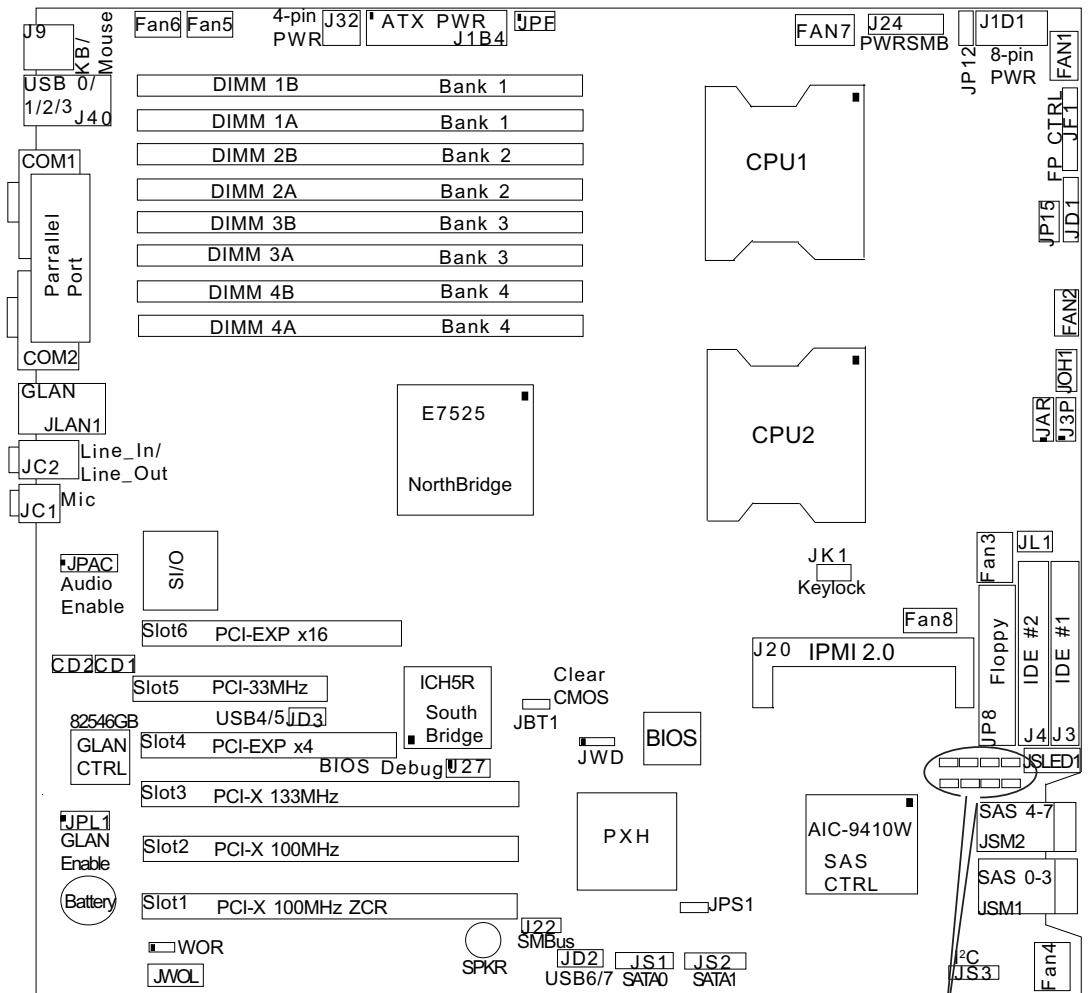
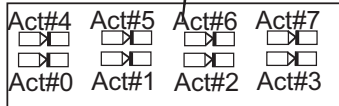

Figure 1-2. SUPER X6DA3-G2/X6DAi-G2 Motherboard Layout
(not drawn to scale)



Onboard SAS_Activity_LED Indicators (*Note: Act=Active)

Act#	Definition	Act#	Definition
Act#0	SAS0:Act	Act#4	SAS4:Act
Act#1	SAS1:Act	Act#5	SAS5:Act
Act#2	SAS2:Act	Act#6	SAS6:Act
Act#3	SAS3:Act	Act#7	SAS7:Act



Notes:

1. Jumpers not indicated are for test purposes only.
2. See Chapter 2 for detailed information on jumpers, I/O ports and JF1 front panel connections.
3. "■" indicates the location of Pin 1.
- 4 The graphics shown in this manual were based upon the latest PCB Revision available at the time of publishing of this manual. The motherboard you've received may or may not look exactly the same as the graphics shown in this manual.
5. All components, features and functionality related to SAS are available on the X6DA3-G2 only.

Quick Reference

Jumper	Description	Default Setting
J3P	3rd PWR Supply Failure Enable	Open (Disabled)
JBT1	CMOS Clear	(See Chapter 2)
JPAC	Audio Enable/Disable	Pins 1-2 (Enabled)
JPF	Force Power	Open (Disabled)
JPL1	Giga-bit LAN Enable/Disable	Pins 1-2 (Enabled)
JPS1	SAS Enable/Disable	Pins 1-2 (Enabled)(* <u>Note</u>)
JWD	Watch Dog Enable	Pins 1-2 (Reset)

Connector	Description
ATX PWR (J1B4)	Primary 24-pin ATX PWR Connector
12V PWR (J1D1, J32)	12V 8-pin PWR/12V 4-pin CPU PWR Connectors
Chassis Intru. (JL1)	Chassis Intrusion Header
COM1 (J6)/COM2 (J38)	COM1/COM2 Serial Port Connectors
DIMM#1A-#4B	Memory (RAM) Slots#(1A,1B, 2A,2B, 3A,3B,4A,4B)
FAN #1-#8	CPU Fans1/2 (Fans 7/8) /Chassis Fans Headers
Floppy (JP8)	Floppy Disk Drive Connector
FP CTRL (JF1)	Front Panel Control
I ² C (J24)	PWR System Management Bus
IDE1(J3), IDE2(J4)	IDE1/2 Hard Disk Drive Connectors
IPMI (J20)	IPMI 2.0 Socket
KB/MOUSE (J9)	Keyboard/Mouse
Keylock (JK1)	Keylock Connection
LAN (JLAN1)	G-bit Ethernet Ports
Line_In/Line_Out/Mic	Audio Line_In/Line_Out (JC2), Microphone (JC1)
OH LED (JOH1)	Overheat LED
Printer (J23)	Parallel (Printer) Port
PWR LED/SPKR(JD1)	PWR LED (Pins1-3), Speaker (Pins 4-7)
PWR Fault (JP12)	Power Fault Connector
PWR Alarm Reset (JAR)	PWR Fail Alarm Reset
SATA0/1 (JS1/JS2)	Serial ATA0/Serial ATA1 Headers
SAS 0/3,4/7 (JSM1/JSM2)	Serial Attached SCSI Connectors(SAS 0-3/4-7)(* <u>Note</u>)
SAS I ² C (JS3)	SAS PWR System Management Bus (* <u>Note</u>)
SAS LEDs (Act#0-Act#7)	Onboard SAS Activity and Status LED Indicators(* <u>Note</u>)
SAS LED (JSLED1)	Backpanel SAS Activity LED Indicators (* <u>Note</u>)
SMB (J22)	System Management Bus Connector
SPKR	Internal Buzzer
WOL (JWOL)	Wake-on-LAN Header
WOR (JWOR)	Wake-on-Ring Header
USB#0-3 (J40)	(Back Panel) Universal Serial Bus Ports
USB#4-5,6-7(JD3, JD2)	(Front Panel) Universal Serial Bus Headers

(*Note: for the X6DA3-G2 only.)

Motherboard Features

CPU

- Single or dual Intel® Xeon™ 64-bit processors at 800 MHz front side (system) bus speed with support of Hyper-Threading (HT), EM64T and Enhanced Intel SpeedStep (EIST)

Using the EM64T Feature

- Install a 64-bit OS (Windows XP Professional x64 Ed, Server 2003x64 Ed.)
- Install a 64-bit OS (Windows XP Professional x64 Ed, Server 2003x64 Ed.)
- Install the 64-bit drivers for all MB components, devices and add-on cards

Using the Hyper-Threading (HT) Technology

- Install an OS that supports HT, including Windows XP/2003 Server and Linux 2.4x. (Under Linux, use the HT compiler to compile the code. For other operating systems, be sure to disable the HT feature in the BIOS.)
- Enable the HT feature in the BIOS (under "Advanced" Setting) before installing a supported OS. (*Note: visit www.Intel.com for CPU support and driver updates.)

Memory

- Eight 240-pin DIMM sockets supporting up to 16 GB Registered ECC DDRII-400 (PC3200) SDRAM (*Memory must be populated in pairs.)

Chipset

- Intel E7525 (North Bridge)+ ICH5R (South Bridge) + PHX (PCI Controller Hub)

Expansion Slots

- One PCI-Express x16 slot (Slot 6)
- One PCI-Express x4 (Slot 4) (using x16 physical slot)
- Three 64-bit PCI-X slots (*One 64-bit PCI-X-133 slot: Slot 3, one PCI-X-100 slot: Slot 2, One PCI-X-100MHz ZCR: Slot 1)
- One 32-bit 33MHz PCI slot (w/PCI Graphic Card support): Slot 5

BIOS

- 8 Mb Phoenix BIOS ROM
- APM 1.2, DMI 2.3, PCI 2.2, ACPI 1.0, Plug and Play (PnP), SMBIOS 2.3

PC Health Monitoring

- Onboard voltage monitors for CPU cores, chipset voltage, 3.3V, +5V, +12V, -12V and 3.3V standby, VBAT
- Fan status monitor by Thermal Management via BIOS
- CPU/chassis temperature monitors
- Environmental temperature monitor via Supero Doctor III
- CPU 4-phase-switching voltage regulator

- CPU thermal trip support for processor protection, +5V standby alert LED
- Power-up mode control for recovery from AC power loss
- System overheat LED and control
- Chassis intrusion detection
- System resource alert via Super Doctor III
- Status Monitor for Fan Speed Control
- Low noise fan control with Pulse Width Modulation (PWM)
- I²C Temperature sensing logic
- Thermal Monitor 2 (TM2) support

ACPI Features

- ACPI/ACPM PWR Management with Main Switch Override Mechanism
- Wake-On-Ring (WOR) and Wake-On-LAN (WOL) Headers
- PWR-On mode for AC power recovery
- Internal/external modem ring-on
- STR-Suspend to RAM

Onboard I/O

- Adaptec AIC 9410W 8-port Serial Attached SCSI Controller (SAS) (*X6DA3-G2 only) (RAID 0, 1)
- One IPMI 2.0 Socket
- One dual-port Intel 82546GB Gigabit Ethernet controller
- 2 EIDE Ultra DMA/100 bus master interfaces
- 1 floppy port interface (up to 2.88 MB)
- 1 EPP/ECP Parallel Port
- PS/2 mouse and PS/2 keyboard ports
- Up to eight USB 2.0 (Universal Serial Bus): (4 ports, 4 headers)
- 2 serial ports
- 2 Serial ATA support (w/RAID 0/RAID 1 support)

Other

- CPU/System Overheat LED
- Suspend-state Indicator
- Console redirection

CD/Diskette Utilities

- BIOS flash upgrade utility and device drivers

Dimensions

- ATX Ext. 12" x 13.05" (304.8 x 331.5 mm)

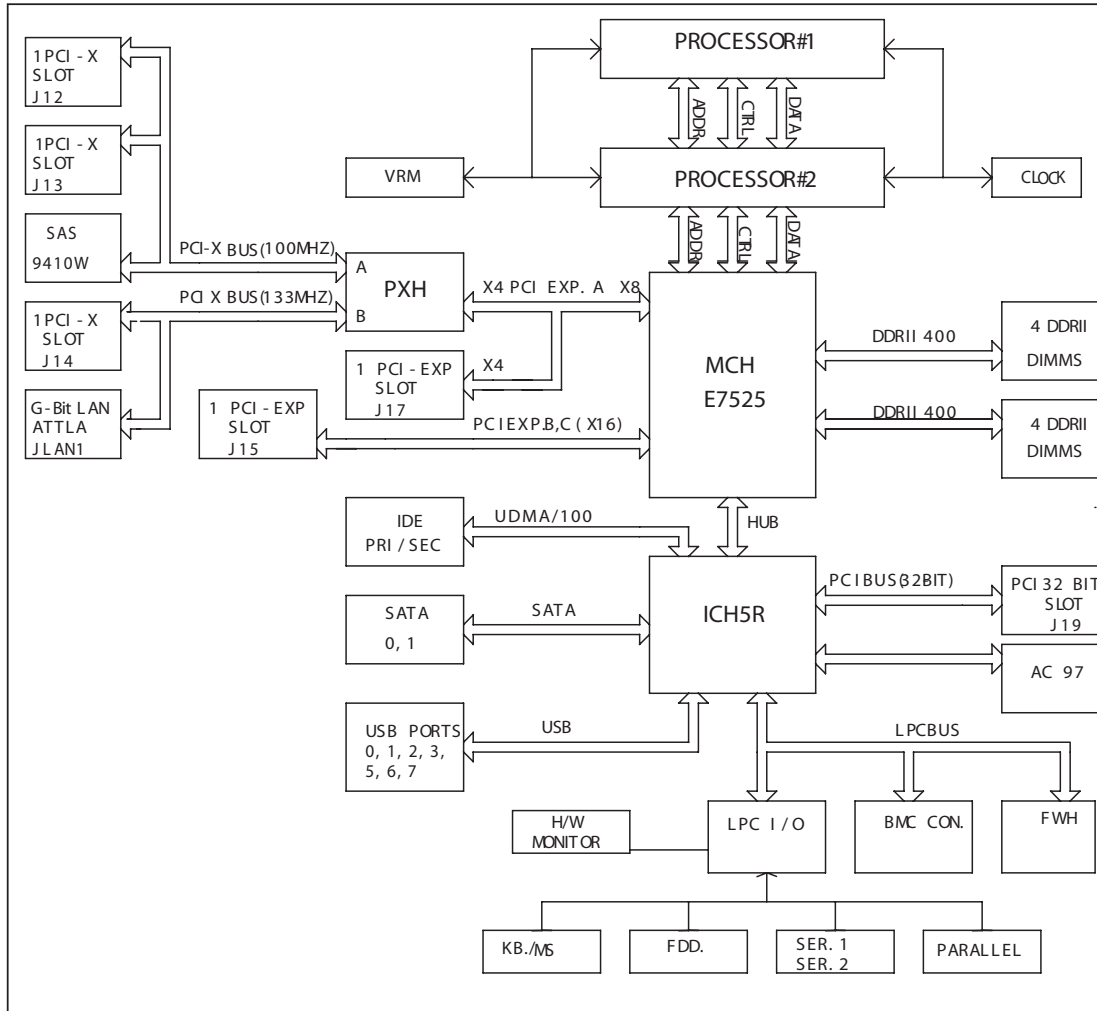

Figure 1-9. Block Diagram of the E7525 Chipset

Note: This is a general block diagram. Please see the previous Motherboard Features pages for details on the features of the motherboard.

1-2 Chipset Overview

Built upon the functionality and the capability of the E7525 chipset, the X6DA3-G2 motherboard provides the performance and feature set required for dual processor-based computer systems, with configuration options optimized for communications, storage, computation or database applications. The Intel E7525 chipset consists of the following components: the E7525 Memory Controller Hub (MCH), the I/O Controller Hub (ICH5R), and the PCI-X Hub (PXH).

The E7525 MCH supports single or dual Xeon EM64T processors with Front Side Bus speeds of up to 800 MHz. Its memory controller provides direct connection to two channels of registered DDR 266/333 or DDRII 400 with a marched system bus address and data bandwidths of up to 2.67 GB/s (DDR 333) or 3.2 GB/s (DDRII-400) per channel. The E7525 also supports the new PCI Express high speed serial I/O interface for superior I/O bandwidth. The MCH provides configurable x16 PCI Express interfaces which may alternatively be configured as two independent x8 PCI Express interfaces. These interfaces support connection of the MCH to a variety of other bridges that are compliant with the PCI Express Interface Specification, Rev. 1.0a. The MCH interfaces with the ICH5R ICH I/O Controller Hub via HI 1.5 Hub Interface. The PXH can be configured to support for 32- or 64-bit PCI devices running at 33 MHz, 66 MHz, 100 MHz, and 133 MHz.

ICH5R System Features

In addition to providing the I/O subsystem with access to the rest of the system, the ICH5R I/O Controller Hub integrates many I/O functions.

The ICH5 I/O Controller Hub integrates: 2-channel Ultra ATA/100 Bus Master IDE Controller, two Serial ATA (SATA) Host w/RAID0, RAID1 support, SMBus 2.0 Controller, LPC/Flash BIOS Interface, PCI 2.2 Interface and System Management Controller.

1-3 Special Features

Recovery from AC Power Loss

BIOS provides a setting for you to determine how the system will respond when AC power is lost and then restored to the system. You can choose for the system to remain powered off (in which case you must hit the power switch to turn it back on) or for it to automatically return to a power-on state. See the Power Lost Control setting in the Advanced BIOS Setup section (Boot Features) to change this setting. The default setting is Last State.

Serial Attached SCSI (SAS) (*SAS: for X6DA3-G2 only)

Serial Link Data Transferring offers cutting-edge technology in data connectivity and scalability. With the AIC 9410W SAS controller built-in, the X6DA3-G2 offers unprecedented I/O throughput, reliability and expandability to the IT Industry. Combined with the capability provided by the onboard ICH5R Chip, the X6DA3-G2 offers a dynamic serial-link transmission infrastructure, supporting both SATA and SAS without any bridging, providing the user with unparalleled data storage expansion and inter-connectivity capability.

1-4 PC Health Monitoring

This section describes the PC health monitoring features of the X6DA3-G2/X6DAi-G2. All have an onboard System Hardware Monitor chip that supports PC health monitoring.

Onboard Voltage Monitors for the CPU Cores, Chipset Voltage, +3.3V, +5V, +12V, -12V, +3.3V Standby, and +5V Standby

An onboard voltage monitor will scan these voltages continuously. Once a voltage becomes unstable, a warning is given or an error message is sent to the screen. Users can adjust the voltage thresholds to define the sensitivity of the voltage monitor.

Fan Status Monitor with Firmware Control

The PC health monitor can check the RPM status of the cooling fans. The onboard 4-pin CPU and chassis fans are controlled by the power management functions. The thermal fan is controlled by the overheat detection logic.

Environmental Temperature Control via Supero DoctorIII

The thermal control sensor monitors the CPU temperature in real time and will turn on the thermal control fan whenever the CPU temperature exceeds a user-defined threshold. The overheat circuitry runs independently from the CPU. It can continue to monitor for overheat conditions even when the CPU is in sleep mode. Once it detects that the CPU temperature is too high, it will automatically turn on the thermal control fan to prevent any overheat damage to the CPU. The onboard chassis

thermal circuitry can monitor the overall system temperature and alert users when the chassis temperature is too high.

CPU Overheat LED and Control

This feature is available when the user enables the CPU overheat warning function in the BIOS. This allows the user to define an overheat temperature. When this temperature is exceeded, both the overheat fan and the warning LED are triggered.

Auto-Switching Voltage Regulator for the CPU Core

The auto-switching voltage regulator can auto-detect and regulate power supply to the CPU. This will allow the regulator to run cooler and thus make the system more stable.

Thermal Management II (TM2)/CPU VRM

When the CPU's temperature reaches a pre-defined threshold, the CPU will slow down, CPU voltage will decrease to reduce CPU's power consumption and heat dissipation to protect the CPU from overheat.

1-5 ACPI Features

ACPI stands for Advanced Configuration and Power Interface. The ACPI specification defines a flexible and abstract hardware interface that provides a standard way to integrate power management features throughout a PC system, including its hardware, operating system and application software. This enables the system to automatically turn on and off peripherals such as CD-ROMs, network cards, hard disk drives and printers. This also includes consumer devices connected to the PC such as VCRs, TVs, telephones and stereos.

In addition to enabling operating system-directed power management, ACPI provides a generic system event mechanism for Plug and Play and an operating system-independent interface for configuration control. ACPI leverages the Plug and Play BIOS data structures while providing a processor architecture-independent implementation that is compatible with Windows 2000, Windows XP, Windows NT 5.0 and Windows 2003.

Slow Blinking LED for Suspend-State Indicator

When the CPU goes into a suspend state, the chassis power LED will start blinking to indicate that the CPU is in suspend mode. When the user presses any key, the CPU will wake-up and the LED will automatically stop blinking and remain on.

Main Switch Override Mechanism

When an ATX power supply is used, the power button can function as a system suspend button to make the system enter a SoftOff state. The monitor will be

suspended and the hard drive will spin down. Depressing the power button again will cause the whole system to wake-up. During the SoftOff state, the ATX power supply provides power to keep the required circuitry in the system alive. In case the system malfunctions and you want to turn off the power, just depress and hold the power button for 4 seconds. This option can be set in the Power section of the BIOS Setup routine.

External Modem Ring-On (WOR)

Wake-up events can be triggered by a device such as the external modem ringing when the system is in the SoftOff state. Note that external modem ring-on can only be used with an ATX 2.01 (or above) compliant power supply.

1-6 Power Supply

As with all computer products, a stable power source is necessary for proper and reliable operation. It is even more important for processors that have high CPU clock rates.

The SUPER X6DA3-G2/X6DAi-G2 accommodates ATX power supplies. Although most power supplies generally meet the specifications required by the CPU, some are inadequate. You should use one that will supply at least 500W of power (***Note: the 12V 8-pin power connector (J1D1) is required for CPU power consumption, and an additional 12V 4-pin power connection (J32) is also required for adequate power supply to the system.**) Also your power supply must supply 1.5A for the Ethernet ports. It is strongly recommended that you use a high quality power supply that meets ATX power supply Specification 2.02 or above. It must also be SSI compliant (info at <http://www.ssiforum.org/>). Additionally, in areas where noisy power transmission is present, you may choose to install a line filter to shield the computer from noise. It is recommended that you also install a power surge protector to help avoid problems caused by power surges.

1-7 Super I/O

The disk drive adapter functions of the Super I/O chip include a floppy disk drive controller that is compatible with industry standard 82077/765, a data separator, write pre-compensation circuitry, decode logic, data rate selection, a clock generator, drive interface control logic and interrupt and DMA logic. The wide range of functions integrated onto the Super I/O greatly reduces the number of components required for interfacing with floppy disk drives. The Super I/O supports 360 K, 720 K, 1.2 M, 1.44 M or 2.88 M disk drives and data transfer rates of 250 Kb/s, 500 Kb/s or 1 Mb/s. It also provides two high-speed, 16550 compatible serial communication ports (UARTs), one of which supports serial infrared communication. Each UART includes a 16-byte send/receive FIFO, a programmable baud rate generator, complete modem control capability and a processor interrupt system. Both UARTs provide

legacy speed with baud rate of up to 115.2 Kbps as well as an advanced speed with baud rates of 250 K, 500 K, or 1 Mb/s, which support higher speed modems.

The Super I/O supports one PC-compatible printer port (SPP), Bi-directional Printer Port (BPP) , Enhanced Parallel Port (EPP) or Extended Capabilities Port (ECP).

The Super I/O provides functions that comply with ACPI (Advanced Configuration and Power Interface), which includes support of legacy and ACPI power management through an SMI or SCI function pin. It also features auto power management to reduce power consumption.

The IRQs, DMAs and I/O space resources of the Super I/O can flexibly adjust to meet ISA PnP requirements, which support ACPI and APM (Advanced Power Management).

Notes

Chapter 2

Installation

2-1 Static-Sensitive Devices

Electric-Static-Discharge (ESD) can damage electronic components. To prevent damage to your system board, it is important to handle it very carefully. The following measures are generally sufficient to protect your equipment from ESD.

Precautions

- Use a grounded wrist strap designed to prevent static discharge.
- Touch a grounded metal object before removing the board from the antistatic bag.
- Handle the board by its edges only; do not touch its components, peripheral chips, memory modules or gold contacts.
- When handling chips or modules, avoid touching their pins.
- Put the motherboard and peripherals back into their antistatic bags when not in use.
- For grounding purposes, make sure your computer chassis provides excellent conductivity between the power supply, the case, the mounting fasteners and the motherboard.
- Use only the correct type of onboard CMOS battery as specified by the manufacturer. Do not install the onboard battery upside down to avoid possible explosion.

Unpacking

The motherboard is shipped in antistatic packaging to avoid static damage. When unpacking the board, make sure the person handling it is static protected.

2-2 Xeon EM64T Processor and Heatsink Installation



When handling the processor package, avoid placing direct pressure on the label area of the fan. Also, do not place the motherboard on a conductive surface, which can damage the BIOS battery and prevent the system from booting up.

IMPORTANT: Always connect the power cord last and always remove it before adding, removing or changing any hardware components. Make sure that you install the processor into the CPU socket **before** you install the CPU heat sink.

Installing Retention Brackets

(*CPU Retention Plates are pre-installed. Pictures shown on right are for reference only.)

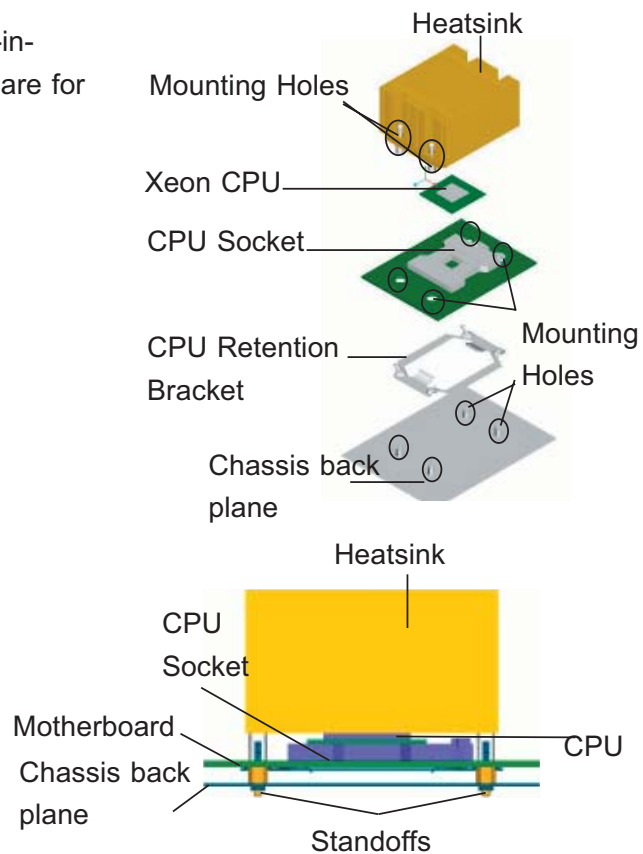

CPU Installation

1. Lift the lever on the CPU socket: lift the lever completely as shown on the picture on the right; otherwise, you will damage the CPU socket when power is applied. (Install CPU1 first.)



Socket lever

2. Insert the CPU in the socket, making sure that pin 1 of the CPU aligns with pin 1 of the socket (both corners are marked with a triangle). When using only one CPU, install it into CPU socket #1 (socket #2 is automatically disabled if only one CPU is used).



Pin 1

3. Press the lever down until you hear the *click*, so you can be sure that the CPU is securely installed in the CPU socket.



Socket lever in the locking Position

Heatsink Installation

1. Do not apply any thermal compound to the heatsink or the CPU die since the required amount has already been applied.

2. Place the heatsink on top of the CPU so that the four mounting holes are aligned with those on the retention mechanism.

3. Screw in two diagonal screws (ie the #1 and the #2 screws) until just snug (-do not fully tighten the screws to avoid possible damage to the CPU.)

4. Finish the installation by fully tightening all four screws.

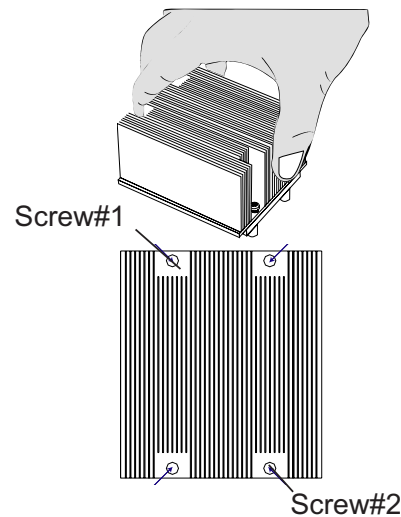

To Un-install the Heatsink

(Caution! We do not recommend that the CPU or the heatsink be removed. However, if you do need to un-install the heatsink, please follow the instructions below to uninstall the heatsink to prevent damage done to the CPU or the CPU socket.)

1. Unscrew and remove the heatsink screws from the motherboard in the sequence as show in the picture on the right.

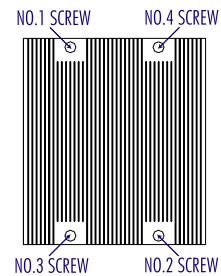

2. Hold the heatsink in the way as show in the picture on the right and gently wriggle the heatsink to loosen it from the CPU. (Do not use excessive force when wriggling the heatsink!!)

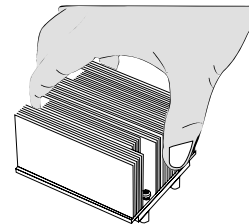

3. Once the CPU is loosened from the heatsink, remove the heatsink from the CPU socket.

4. Clean the surface of the CPU and the heatsink to get rid of the old thermal grease. Reapply the proper amount of thermal grease on the surface before you re-install the CPU and the heatsink.

Figure 2-1. PGA604 Socket: Empty and with Processor Installed



Warning! Make sure you lift the lever completely when installing the CPU. If the lever is only partly raised, damage to the socket or CPU may occur.

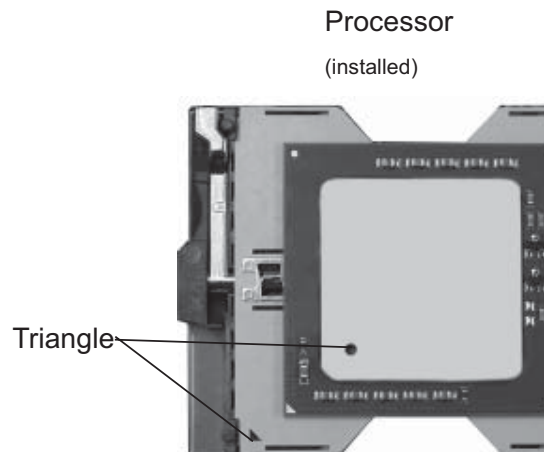
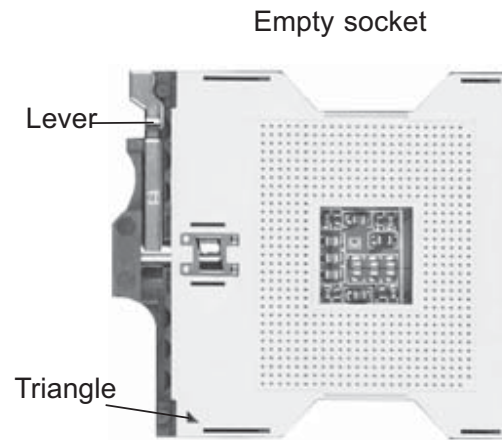

Mounting the Motherboard in the Chassis

All motherboards have standard mounting holes to fit different types of chassis. Make sure that the locations of all the mounting holes for both motherboard and chassis match. Make sure that the metal standoffs click in or are screwed in tightly. Then, use a screwdriver to secure the motherboard onto the motherboard tray. (*Note: some components are very close to the mounting holes. Please take precautionary measures to prevent damage done to these components when you install the motherboard to the chassis.)

2-3 Installing DIMMs

Note: Check the Supermicro web site for recommended memory modules.



CAUTION

Exercise extreme care when installing or removing DIMM modules to prevent any possible damage. Also note that the memory is interleaved to improve performance (see step 1).

DIMM Installation (See Figure 2-2)

1. Insert the desired number of DIMMs into the memory slots, starting with DIMM #1A. The memory scheme is interleaved so you must install two modules at a time, beginning with DIMM #1A, then DIMM #1B, and so on.
2. Insert each DIMM module vertically into its slot. Pay attention to the notch along the bottom of the module to prevent inserting the DIMM module incorrectly.
3. Gently press down on the DIMM module until it snaps into place in the slot. Repeat for all modules (see step 1 above).

Memory Support

The X6DA3-G2/X6DAi-G2 supports up to 16GB of dual channel ECC Registered DDR II 400 SDRAM. This motherboard supports Interleaved memory. Populating DIMM#1A, DIMM#1B, and/or DIMM#2A, DIMM#2B with a pair (or pairs) of memory modules that are of the same size and of the same type will result in dual channel, two-way interleaved memory.

Notes: 1. Single rank memory is recommended for configurations with 6 or more modules. 2. Due to OS limitations, some operating systems may not support more than 4 GB of memory.

Figure 2-2. Installing and Removing DIMMs

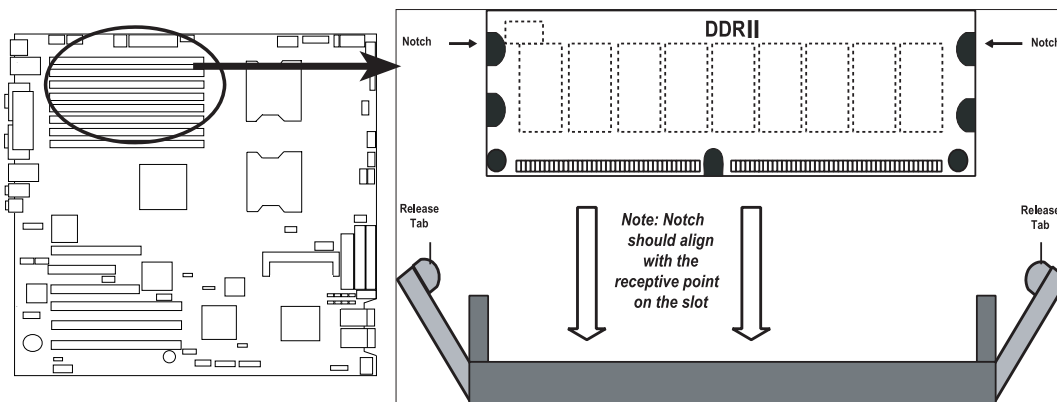

To Install: Insert module vertically and press down until it snaps into place. Pay attention to the alignment notch at the bottom.

To Remove:

Use your thumbs to gently push the release tabs near both ends of the module. This should release it from the slot.

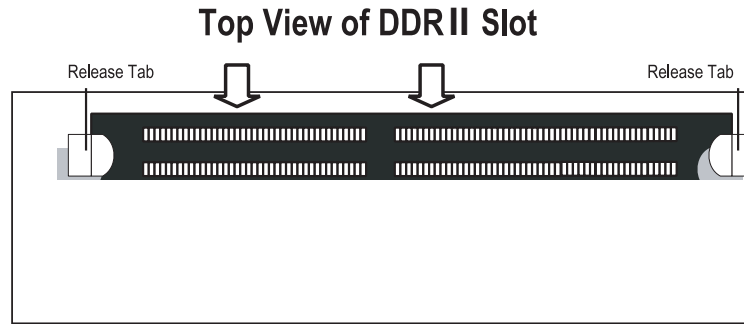

2-4 Control Panel Connectors/I/O Ports

The I/O ports are color coded in conformance with the PC 99 specification. See Figure 2-3 below for the colors and locations of the various I/O ports.

A. Back Panel Connectors/I/O Ports

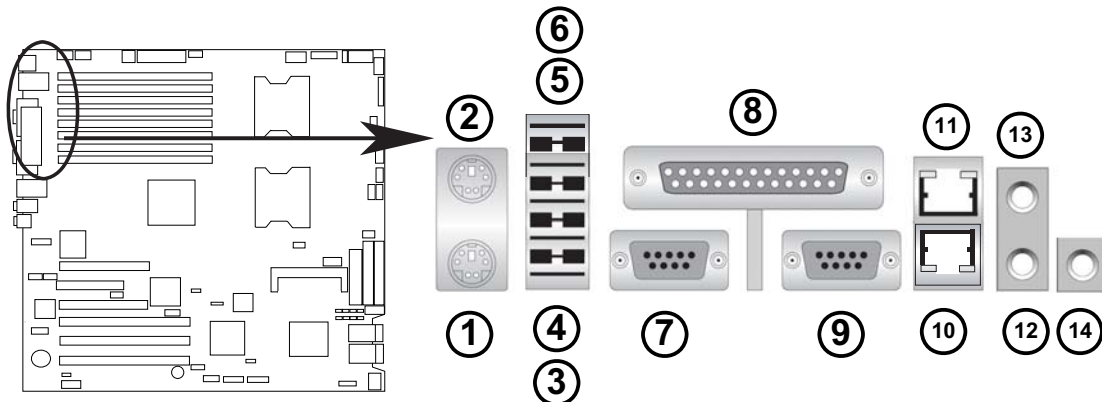

Figure 2-3. Back Panel I/O Port Locations and Definitions

Back Panel Connectors

1. Keyboard (Purple)
2. PS/2 Mouse (Green)
3. Back Panel USB Port 0
4. Back Panel USB Port 1
5. Back Panel USB Port 2
6. Back Panel USB Port 3
7. COM Port 1 (Turquoise)
8. Parallel Port (Printer)
9. COM Port 2 (Turquoise)
10. Gigabit LAN 2
11. Gigabit LAN 1
12. Line-In
13. Line-Out
14. Mic.

(*See Section 2-5 for details.)

B. Front Control Panel

JF1 contains header pins for various buttons and indicators that are normally located on a control panel at the front of the chassis. These connectors are designed specifically for use with Supermicro server chassis. See Figure 2-4 for the descriptions of the various control panel buttons and LED indicators. Refer to the following section for descriptions and pin definitions.

Figure 2-4. JF1 Header Pins

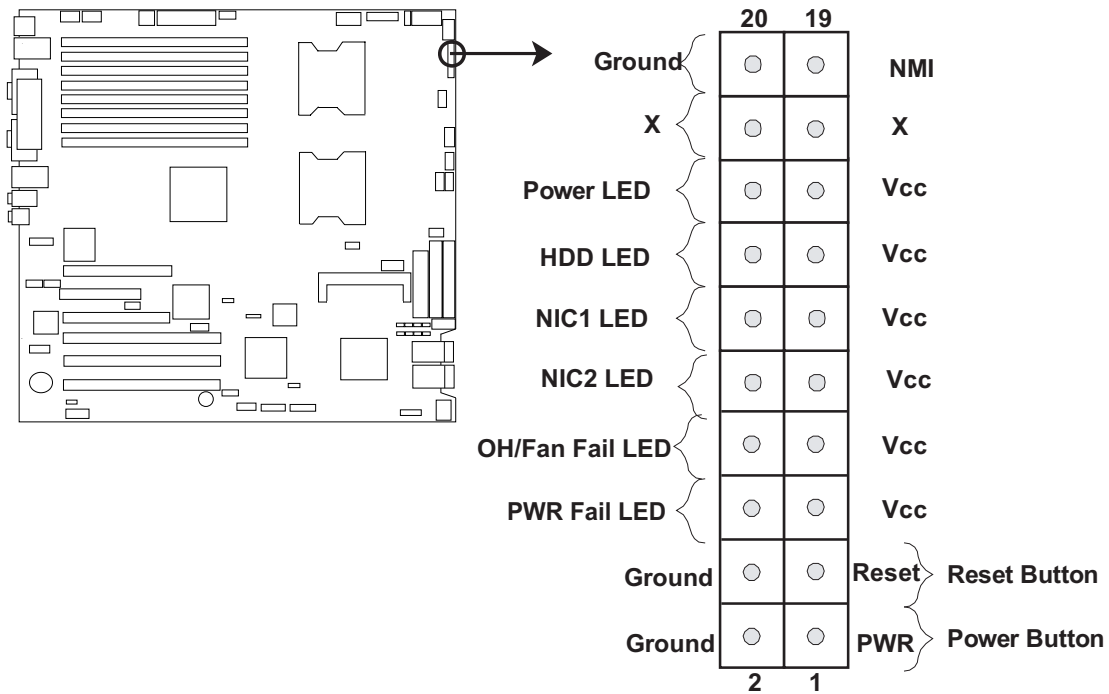

C. Front Control Panel Pin Definitions

NMI Button

The non-maskable interrupt button header is located on pins 19 and 20 of JF1. Refer to the table on the right for pin definitions.

NMI Button Pin Definitions (JF1)	
Pin#	Definition
19	Control
20	Ground

Power LED

The Power LED connection is located on pins 15 and 16 of JF1. Refer to the table on the right for pin definitions.

Power LED Pin Definitions (JF1)	
Pin#	Definition
15	+5V
16	Ground

A. NMI

B. PWR LED

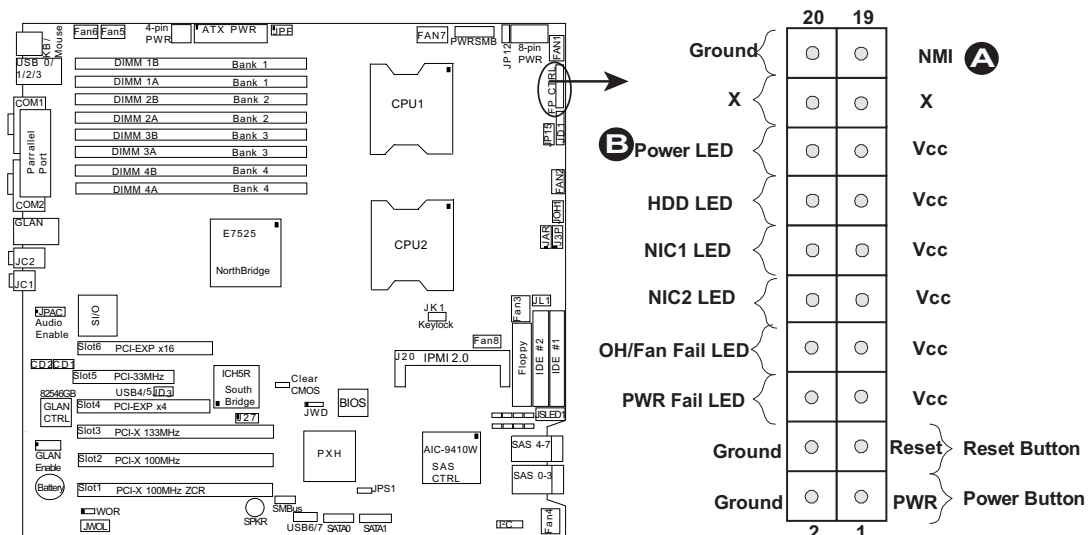

HDD LED

The HDD LED connection is located on pins 13 and 14 of JF1. Attach the hard drive LED cable here to display disk activity (for any hard drives on the system, including SAS, Serial ATA and IDE). See the table on the right for pin definitions.

HDD LED Pin Definitions (JF1)	
Pin#	Definition
13	+5V
14	HD Active

NIC1/NIC2 LED Indicators

The NIC (Network Interface Controller) LED connection for GLAN port1 is located on pins 11 and 12 of JF1 and the LED connection for GLAN Port2 is on Pins 9 and 10. Attach the NIC LED cables to display network activity. Refer to the table on the right for pin definitions.

GLAN1/2 LED Pin Definitions (JF1)	
Pin#	Definition
9/11	Vcc
10/12	Ground

- A. HDD LED
- B. NIC1 LED
- C. NIC2 LED

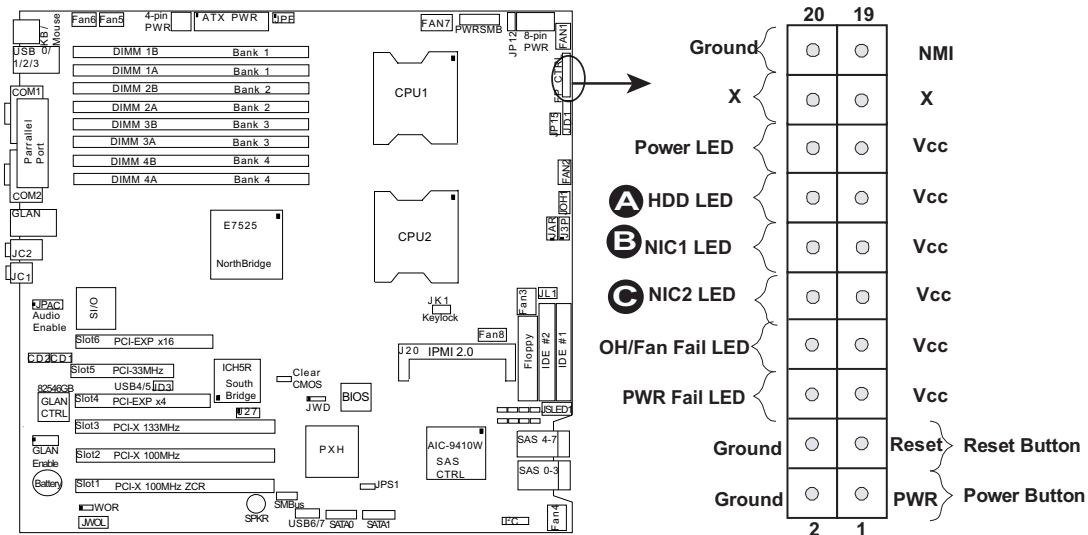

Overheat/Fan Fail LED (OH)

Connect an LED to the OH/Fan Fail connection on pins 7 and 8 of JF1 to provide advanced warning of chassis overheating or fan failure. Refer to the table on the right for pin definitions.

OH/Fan Fail LED Pin Definitions (JF1)	
Pin#	Definition
7	Vcc
8	Ground

OH/Fan Fail Indicator Status	
State	Definition
Off	Normal
On	Overheat
Flashing	Fan Fail

Power Fail LED

The Power Fail LED connection is located on pins 5 and 6 of JF1. Refer to the table on the right for pin definitions.

PWR Fail LED Pin Definitions (JF1)	
Pin#	Definition
5	Vcc
6	Ground

A. OH/Fan Fail LED

B. PWR Supply Fail

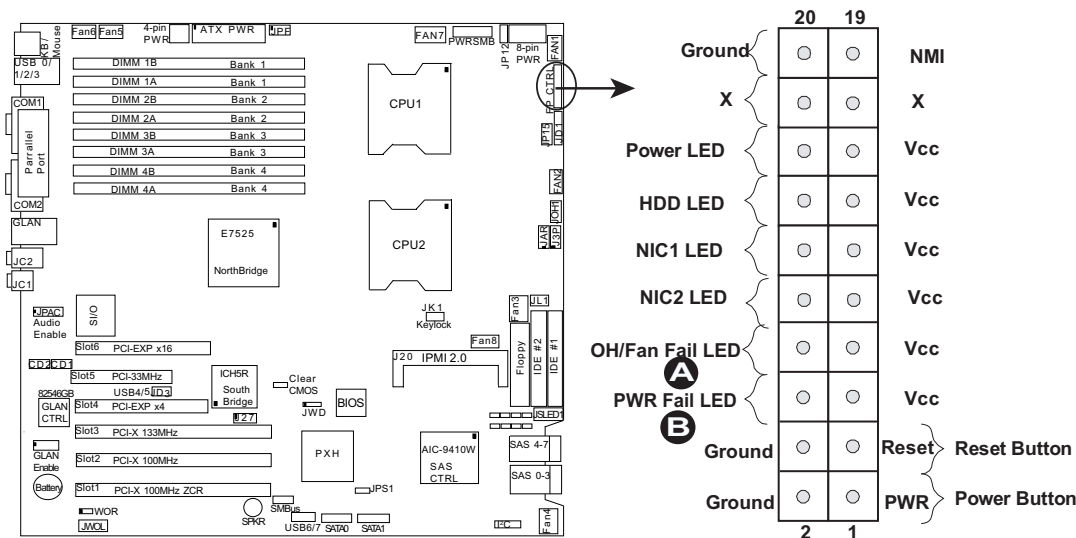

Reset Button

The Reset Button connection is located on pins 3 and 4 of JF1. Attach it to the hardware reset switch on the computer case. Refer to the table on the right for pin definitions.

Reset Button Pin Definitions (JF1)	
Pin#	Definition
3	Reset
4	Ground

Power Button

The Power Button connection is located on pins 1 and 2 of JF1. Momentarily contacting both pins will power on/off the system. This button can also be configured to function as a suspend button (with a setting in BIOS - see Chapter 4). To turn off the power when set to suspend mode, depress the button for at least 4 seconds. Refer to the table on the right for pin definitions.

Power Button Pin Definitions (JF1)	
Pin#	Definition
1	Signal
2	+3V Standby

A. Reset Button

B. PWR Button

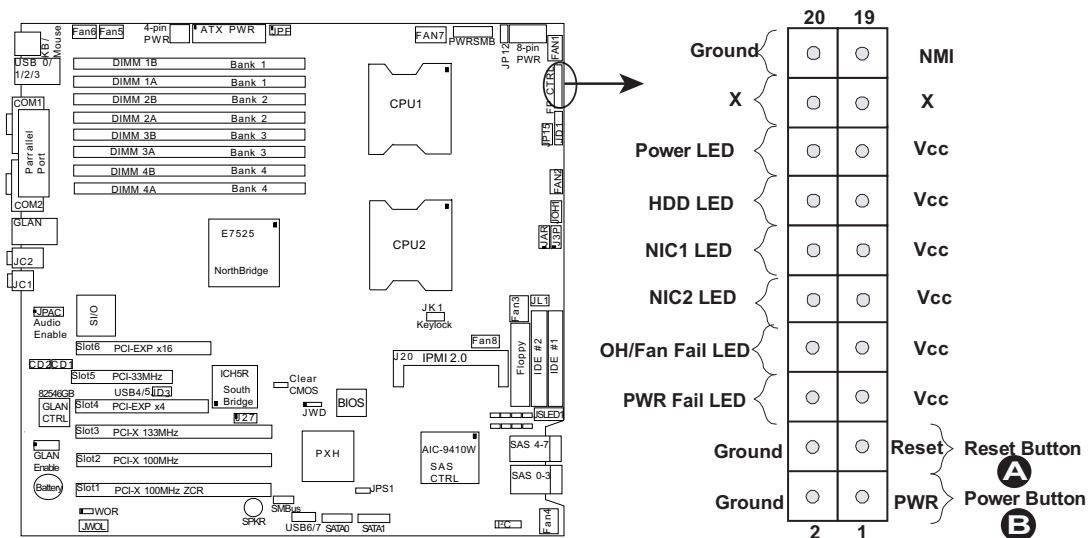

2-5 Connecting Cables

ATX Power Connector

There are a 24-pin main power supply connector(PW1:J1B4) and a 4-pin CPU PWR connector (J32) on the motherboard. These power connectors meet the SSI EPS 12V specification. The 4-pin 12V PWR supply is required to provide adequate power to the system. See the table on the right for pin definitions. For CPU PWR (J1D1), please refer to the item listed below.

Pin#	Definition	Pin #	Definition
13	+3.3V	1	+3.3V
14	-12V	2	+3.3V
15	COM	3	COM
16	PS_ON	4	+5V
17	COM	5	COM
18	COM	6	+5V
19	COM	7	COM
20	Res (NC)	8	PWR_OK
21	+5V	9	5VSB
22	+5V	10	+12V
23	+5V	11	+12V
24	COM	12	+3.3V

Processor Power Connector

In addition to the Primary ATX power connector (above), the 12V 8-pin CPU PWR connector at J1D1 must also be connected to your power supply. See the table on the right for pin definitions.

Required Connection

Pins	Definition
1 and 2	Ground
3 and 4	+12V

Required Connection

Pins	Definition
1 through 4	Ground
5 through 8	+12V

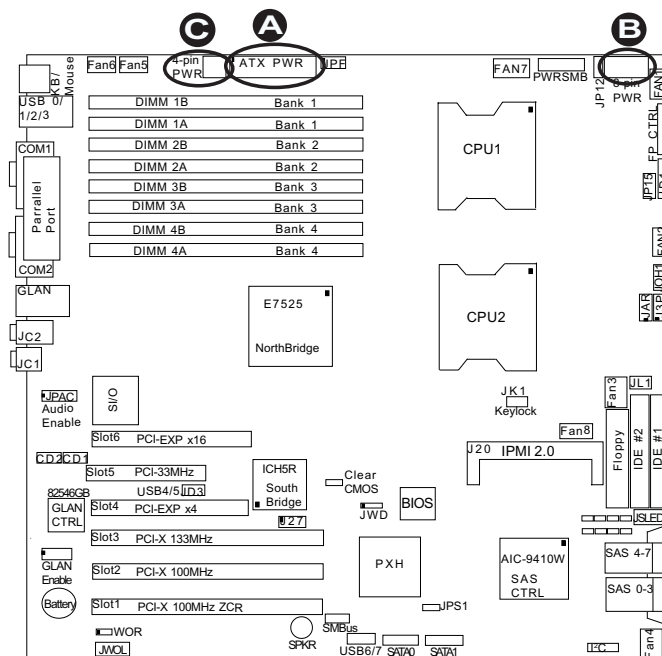

A. 24-pin ATX PWR

B. 8-pin Processor PWR

C. 4-pin PWR

Universal Serial Bus (USB)

There are eight USB 2.0 (Universal Serial Bus) ports/headers on the motherboard. Four of them are Back Panel USB ports (USB#0-3: J40), and the other four are Front Panel USB headers (USB#4,5-JD3, USB#6,7-JD2). See the tables on the right for pin definitions.

Back Panel USB (USB0/1/2/3)	
Pin#	Definitions
1	+5V
2	PO-
3	PO+
4	Ground
5	N/A

Front Panel USB (USB6/7)	
Pin#	Definition
1	Vcc
2	Data-
3	Data+
4	Ground
5	NA

Front Panel USB Pin Definitions (USB4/5)			
USB4		USB5	
Pin #	Definition	Pin #	Definition
1	+5V	1	+5V
2	PO-	2	PO-
3	PO+	3	PO+
4	Ground	4	Ground
5	Key	5	No connection

Chassis Intrusion

A Chassis Intrusion header (JL1) is located next to the IDE ports on the motherboard. Attach the appropriate cable from the chassis to inform you of a chassis intrusion when the chassis is opened.

Chassis Intrusion Pin Definitions (JL1)	
Pin#	Definition
1	Intrusion Input
2	Ground

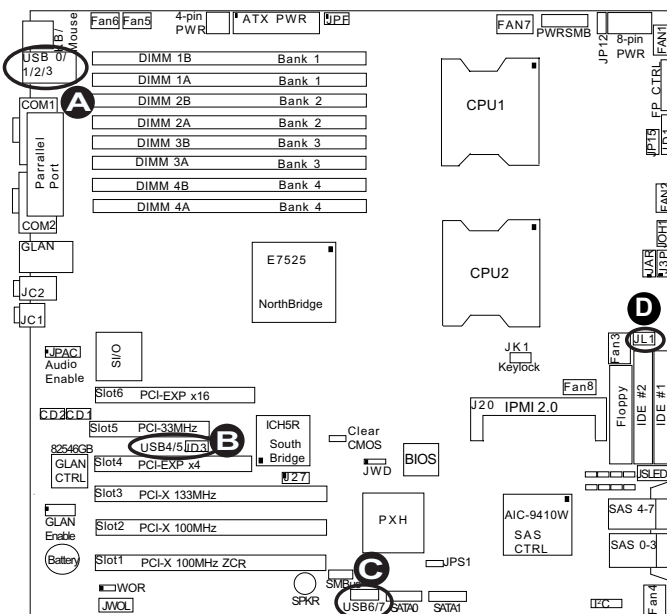

- A. Backpanel USB 0-3
- B. Front Panel USB 4-5
- C. Front Panel USB 6-7
- D. Chassis Intrusion

Fan Headers

The X6DA3-G2/X6DAi-G2 has six chassis/system fan headers (Fan1 to Fan6) and two CPU Fans (Fans 7/8). (*Note: all these fans are 4-pin fans. However, Pins 1-3 of the fan headers are backward compatible with the traditional 3-pin fans.) See the table on the right for pin definitions. (*The onboard fan speeds are controlled by Thermal Management via BIOS Hardware Monitor in the Advanced Setting. Note: Default: Disabled, When using Thermal Management setting, please use all 3-pin fans or all 4-pin fans on the motherboard.)

Fan Header Pin Definitions (Fan1-8)	
Pin#	Definition
1	Ground
2	+12V
3	Tachometer
4	PWR Modulation

Keylock

The keyboard lock connection is designated JK1. Utilizing this header allows you to inhibit any actions made on the keyboard, effectively "locking" it.

Keylock Pin Definitions	
Pin#	Definition
1	Ground
2	Keylock R-N

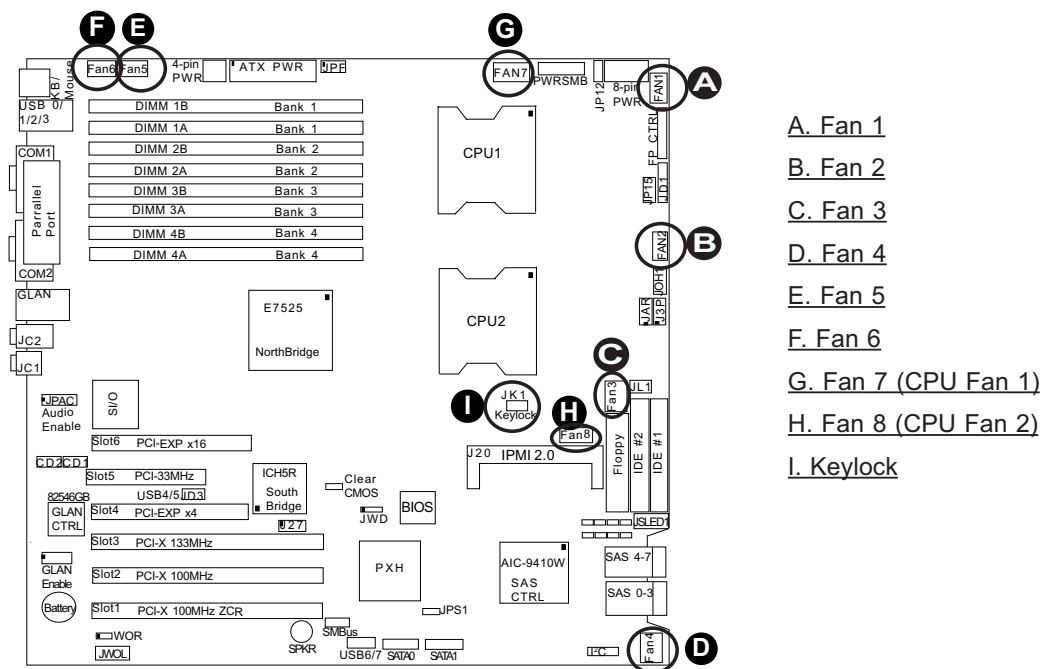

ATX PS/2 Keyboard and PS/2 Mouse Ports

The ATX PS/2 keyboard and the PS/2 mouse are located at J9. See the table on the right for pin definitions. (The mouse port is above the keyboard port. See the table on the right for pin definitions.)

Pin#	Definition
1	Data
2	NC
3	Ground
4	VCC
5	Clock
6	NC

Serial Ports

COM Port1(J6) and COM Port2(J38) are located on the IO Backpanel. See the table on the right for pin definitions.

Pin #	Definition	Pin #	Definition
1	CD	6	DSR
2	RD	7	RTS
3	TD	8	CTS
4	DTR	9	RI
5	Ground		

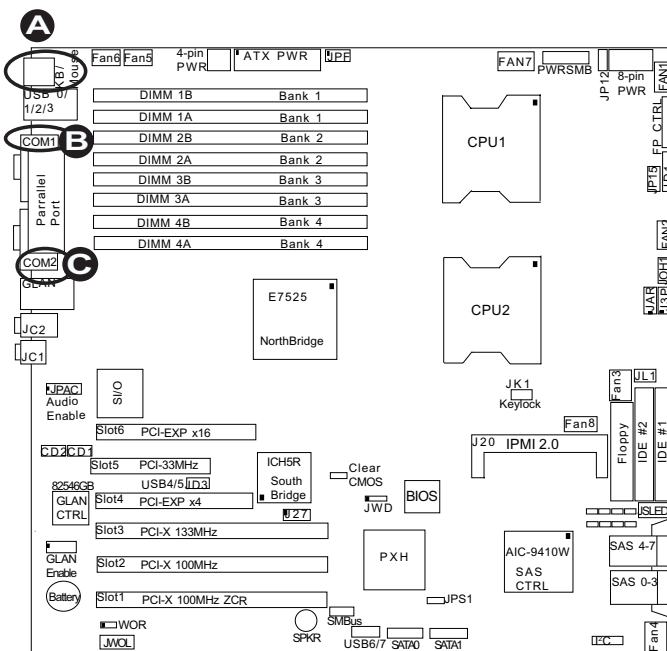

A. Keyboard/Mouse

B. COM1

C. COM2

Wake-On-Ring

The Wake-On-Ring header is designated JWOR. This function allows your computer to receive and "wake-up" by an incoming call to the modem when in suspend state. See the table on the right for pin definitions. You must have a Wake-On-Ring card and cable to use this feature.

Wake-On-LAN Pin Definitions (JWOL)	
Pin#	Definition
1	+5V Standby
2	Ground
3	Wake-up

Wake-On-LAN

The Wake-On-LAN header is located at JWOL on the motherboard. See the table on the right for pin definitions. (You must also have a LAN card with a Wake-On-LAN connector and cable to use this feature.)

Wake-On-Ring Pin Definitions (JWOR)	
Pin#	Definition
1	Ground
2	Wake-up

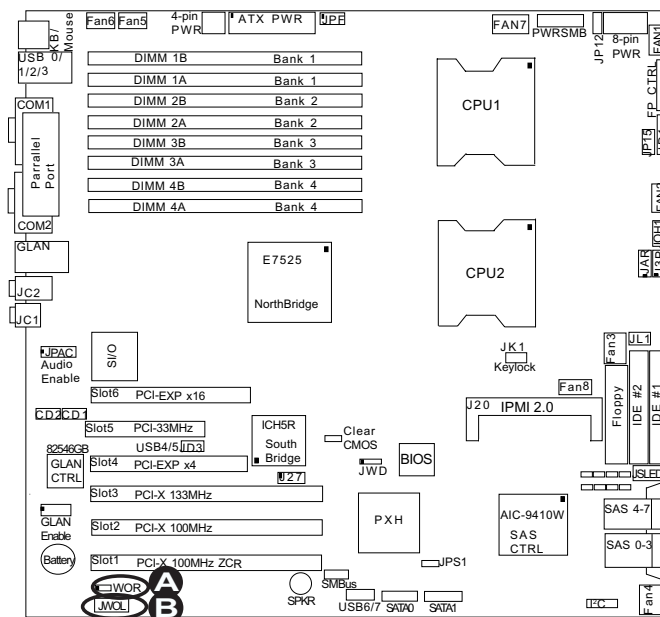

A. WOR

B. WOL

GLAN 1/2 (Giga-bit Ethernet Ports)

Two G-bit Ethernet ports are designated JLAN1 on the IO backplane. This port accepts RJ45 type cables.



Power LED/Speaker

On the JD1 header, pins 1-3 are for a power LED and pins 4-7 are for the speaker. See the table on the right for speaker pin definitions. **Note:** The speaker connector pins are for use with an external speaker. If you wish to use the onboard speaker, you should close pins 6-7 with a jumper.

Speaker Connector	
Pin Setting	Definition
Pins 6-7	Internal Speaker
Pins 4-7	External Speaker

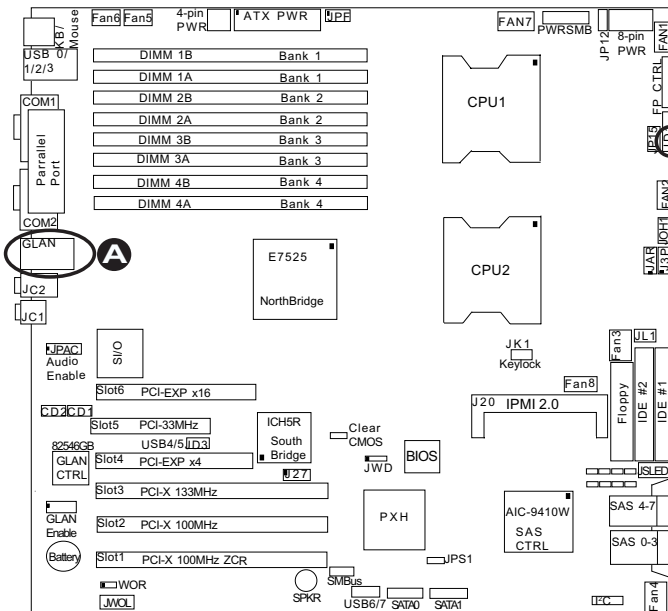

- A. GLAN1/2
- B. PWR LED/Speaker

Power Fault

Connect a cable from your power supply to the Power Fail header (JP12) to provide warning of power supply failure. This warning signal is passed through the PWR_LED pin to indicate of a power failure on the chassis. See the table on the right for pin definitions.

PWR Supply Fail LED Pin Definitions	
Pin#	Definition
1	PWR 1: Fail
2	PWR 2: Fail
3	PWR 3: Fail
4	Signal: Alarm Reset

Note: This feature is only available when using Supermicro redundant power supplies.

Alarm Reset

If three power supplies are installed and Alarm Reset (JAR) is enabled, the system will notify you when any of the three power modules fails. Connect JAR to a micro-switch to enable you to turn off the alarm that is activated when a power module fails. See the table on the right for pin definitions.

Alarm Reset	
Pin Setting	Definition
Pin 1	Ground
Pin 2	+5V

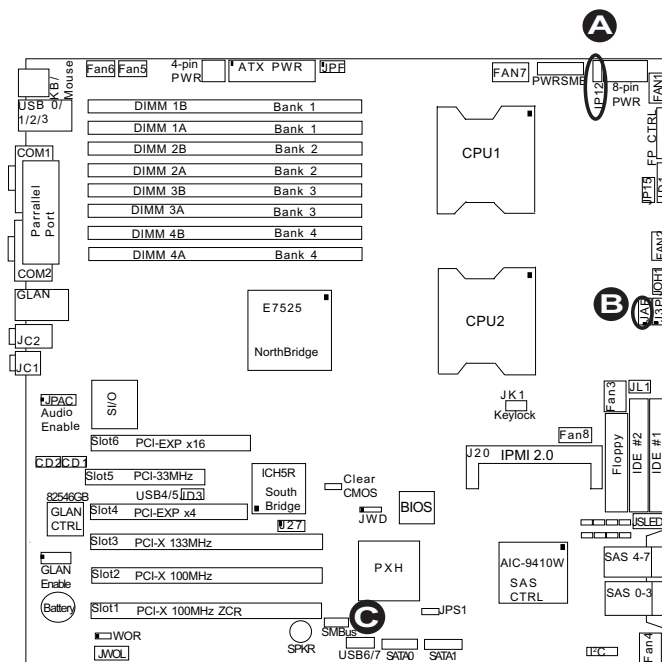

A. Power Fault
 B. Alarm Reset

Overheat LED/Fan Fail (JOH1)

The JOH1 header is used to connect an LED to provide warning of chassis overheating. This LED will blink to indicate a fan failure. Refer to the table on right for pin definitions.

Overheat LED Pin Definitions	
Pin#	Definition
1	5vDC
2	OH Active

OH/Fan Fail LED	
State	Message
Solid	Overheat
Blinking	Fan Fail

SMB

A System Management Bus header is located at J22. Connect the appropriate cable here to utilize SMB on your system.

SMB Header Pin Definitions	
Pin#	Definition
1	Data
2	Ground
3	Clock
4	No Connection

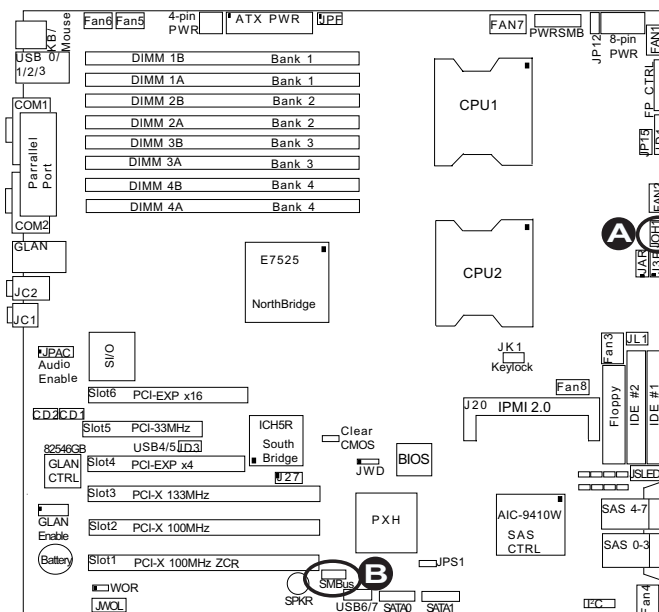

A. OH/Fan Fail LED

B. SMB

Power SMB (I² C) Connector

Power SMB (I² C) Connector (J24) monitors the status of PWR Supply, Fan and system temperature. See the table on the right for pin definitions.

PWR SMB Pin Definitions	
Pin#	Definition
1	Clock
2	Data
3	PWR Fail
4	Ground
5	+3.3V

SAS SMB Power (I²C) Connector (*X6DA3-G2 only)

Adaptec SAS I²C Connector (JS3) monitors the status of Power Supply System Management Bus for SAS ports 0-7. See the table on the right for pin definitions.

SAS SMB PWR Pin Definitions	
Pin#	Definition
1	TWSI_SDA
2	Ground
3	TWSI_SCK

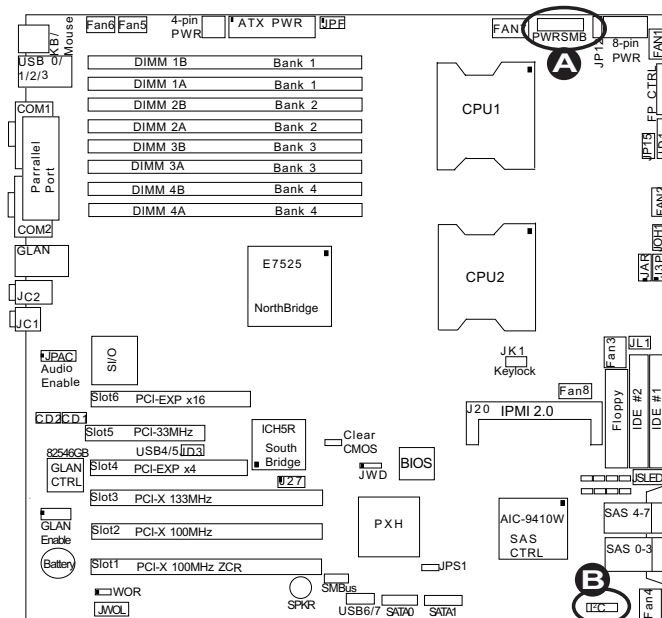

- A. PWR SMB
- B. SAS SMB PWR

AC'97 Audio & Audio Enable

AC'97 provides high quality onboard audio. The X6DA3-G2/X6DAi-G2 features 6-channel sound for front L&R, rear L&R, center and subwoofer speakers. This feature is activated with the Advanced software (in the CD-ROM included with your motherboard). Sound is then output through the Line In, Line Out and MIC jacks (see at right). To activate the Onboard Audio, please enable the Jumper: JPAC. See the table on right for pin definitions.

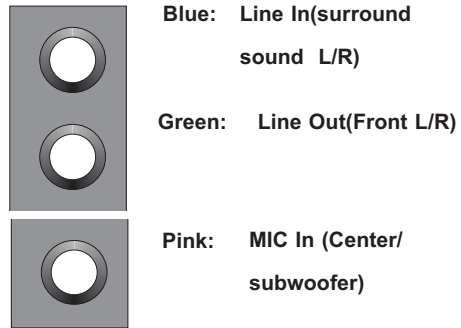

CD1 Pin Definition	
Pin#	Definition
1	Left
2	Ground
3	Ground
4	Right

CD2 Pin Definition	
Pin#	Definition
1	Right
2	Ground
3	Left
4	Ground

CD Connectors

Two CD connectors (CD1, CD2) are located next to the GLAN Controller. See the tables on the right for pin definitions.

Audio Enable/Disable

JPAC enables or disables Audio Controller on the motherboard. See the table on the right for jumper settings. The default setting is enabled.

Audio Enable(JPAC)	
Pin#	Definition
1-2	Enabled (*default)
2-3	Disabled

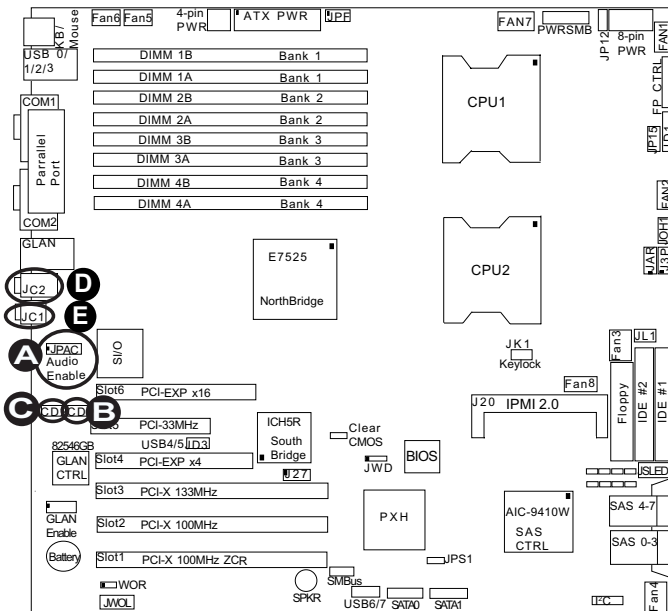

- A. Audio Enable (JPAC)
- B. CD1
- C. CD2
- D. Lin In/Lin Out
- E. Mic.

2-6 Jumper Settings

Explanation of Jumpers

To modify the operation of the motherboard, jumpers can be used to choose between optional settings. Jumpers create shorts between two pins to change the function of the connector. Pin 1 is identified with a square solder pad on the printed circuit board. See the motherboard layout pages for jumper locations.

Note: On two pin jumpers, "Closed" means the jumper is on and "Open" means the jumper is off the pins.

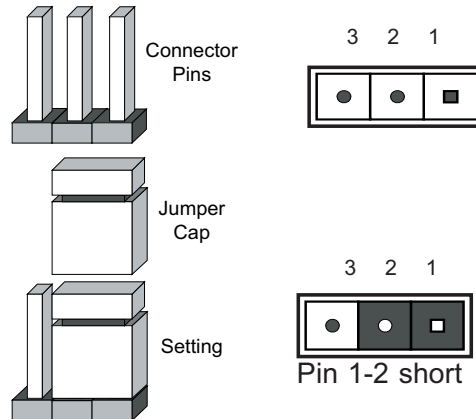

GLAN Enable/Disable

JPL1 enables or disables the GLAN port on the motherboard. See the table on the right for jumper settings. The default setting is enabled.

GLAN Enable	
Pin#	Definition
1-2	Enabled (*default)
2-3	Disabled

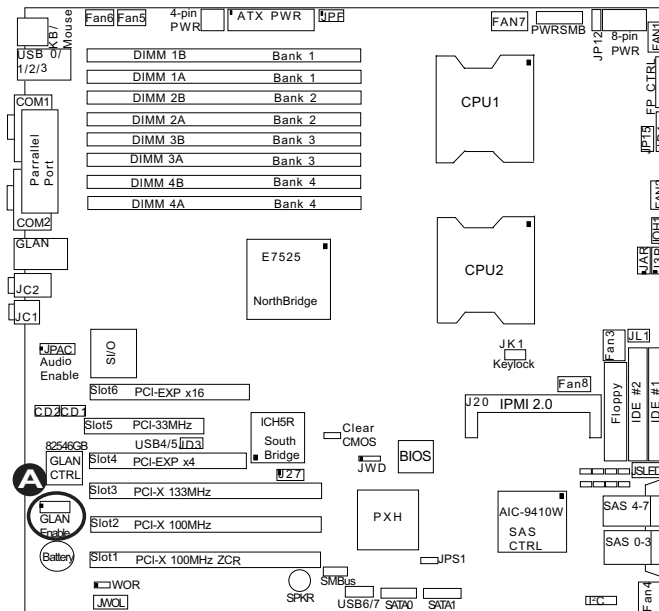

A. GLAN Enable

CMOS Clear

JBT1 is used to clear CMOS. Instead of pins, this "jumper" consists of contact pads to prevent the accidental clearing of CMOS. To clear CMOS, use a metal object such as a small screwdriver to touch both pads at the same time to short the connection. Always remove the AC power cord from the system before clearing CMOS. **Note:** For an ATX power supply, you must completely shut down the system, remove the AC power cord and then short JBT1 to clear CMOS.



SAS Controller Enable/ Disable (*X6DA3-G2 only)

JPS1 enables or disables the AIC 9140W Adaptec SAS Controller on the motherboard. See the table on the right for jumper settings. The default setting is enabled.

SAS Controller Enable Jumper Settings	
Jumper Setting	Definition
Pins 1-2	Enabled (*default)
Pins 2-3	Disabled

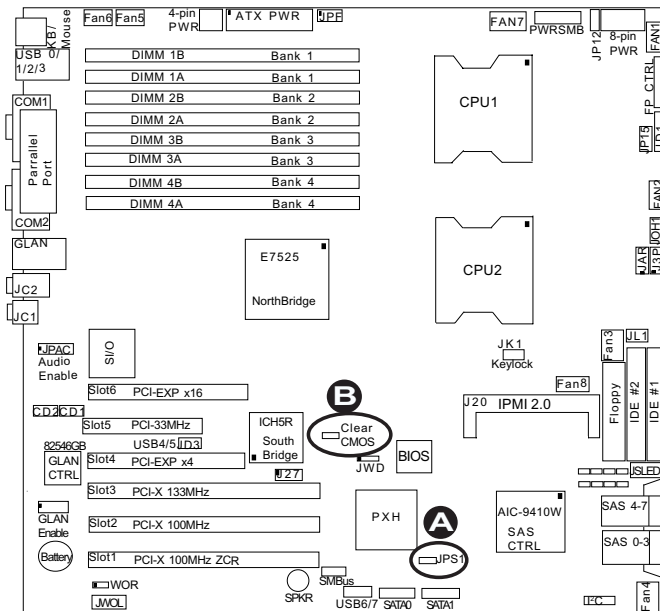

- A. SAS Enable
- B. Clear CMOS

Watch Dog Enable/Disable

JWD controls the Watch Dog function. Watch Dog is a system monitor that can reboot the system when a software application is “hung up”. Pins 1-2 will cause WD to reset the system if an application is hung up. Pins 2-3 will generate a non-maskable interrupt signal for the application that is hung up. See the table on the right for jumper settings. Watch Dog must also be enabled in BIOS.

Watch Dog Jumper Settings (JWD)	
Jumper Setting	Definition
Pins 1-2	Reset (*default)
Pins 2-3	NMI
Open	Disabled

Note: When enabled, the user needs to write their own application software in order to disable the Watch Dog Timer.

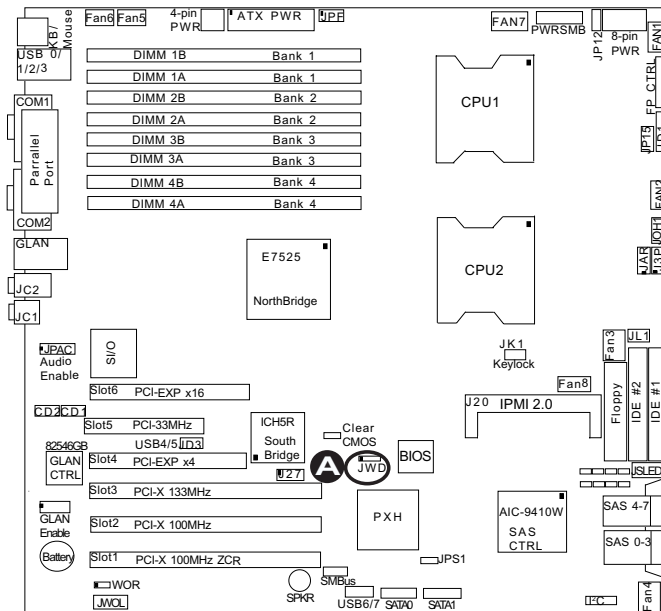

A. Watch Dog

3rd PWR Supply PWR Fault Detect (J3P)

The system can notify you in the event of a power supply failure. This feature available when three power supply units are installed in the chassis with one acting as a backup. If you only have one or two power supply units installed, you should disable this (the default setting) with J3P to prevent false alarms.

3rd PWR Supply PWR Fault Jumper Settings	
Jumper Setting	Definition
Closed	Enabled
Open	Disabled (*Default)

Power Force On Enable/Disable

Jumper JPF allows you to enable (force on) or disable the Power Force-On function. If enabled, the power will always stay on automatically. If this function is disabled (the normal setting), the user needs to press the power button to power on the system.

Power Force On Enable/Disable Jumper Settings (JPF)	
Jumper Setting	Definition
Open	Normal (*default)
Closed	Force On

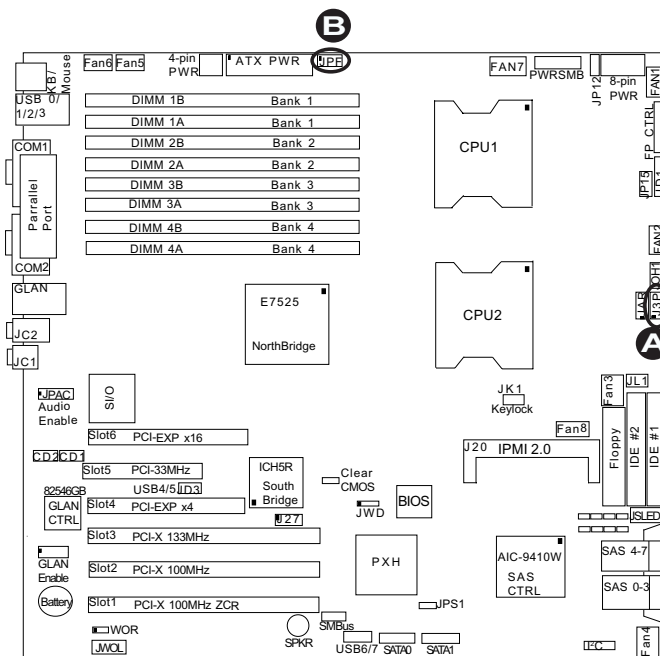

- A. 3rd PWR Fail
- B. PWR Force On

2-8 Onboard Indicators

GLAN LEDs

There are two GLAN ports on the motherboard. Each Gigabit Ethernet LAN port has two LEDs. The green LED indicates activity, while the power LED may be green, orange or off to indicate the speed of the connection. See the table at right for the status associated with the second LED.

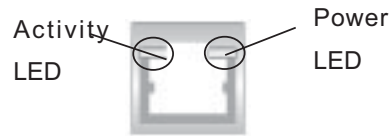

GLAN Activity Indicator	
LED Color	Definition
Green	GLAN Active

GLAN Power Indicator	
LED Color	Definition
Off	No Connection
Green	10/100 Mbps
Amber	1 Gbps

Backpanel SAS Activity LED Header (*X6DA3-G2 only)

Backpanel SAS Activity LED Header (JSLED1), located next to IDE1, indicates SAS Activity status. See the table on the right for pin definitions. (*Note: SAS Common LED will be activated when any of SAS0 to SAS7 LEDs is activated.)

Backpanel SAS_ACT_Output Pin Definitions			
Pin#	Definition	Pin#	Definition
1	SAS0:Act	6	SAS4:Act
2	SAS1:Act	7	SAS5:Act
3	SAS2:Act	8	SAS6:Act
4	SAS3:Act	9	SAS7:Act
5	*SAS Common	10	NC

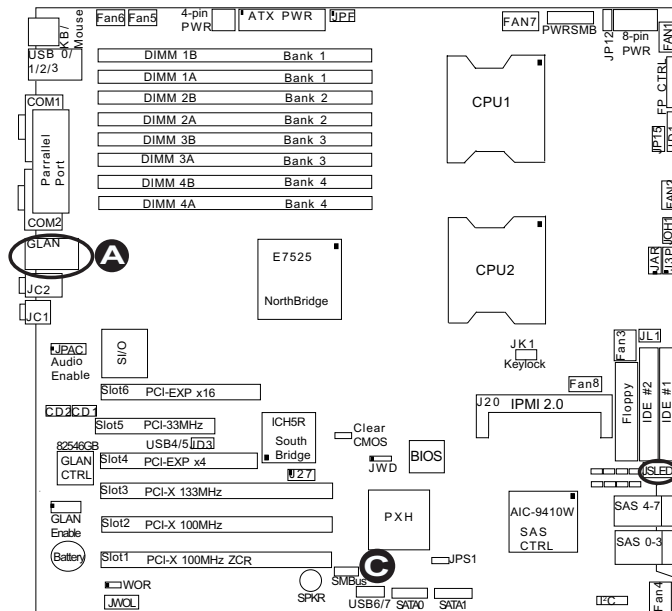

A. GLAN LEDs

B. Backpanel SAS LEDs

Onboard SAS Activity LED Indicators (*X6DA3-G2 only)

There are eight Onboard SAS Activity LED indicators on the X6DA3-G2. LED Indicators Act#0 to Act#7 indicate the activity status of onboard SAS connectors. See the table on the right for LED settings.

Act#	Definition	Act#	Definition
Act#0	SAS0:Act	Act#4	SAS4:Act
Act#1	SAS1:Act	Act#5	SAS5:Act
Act#2	SAS2:Act	Act#6	SAS6:Act
Act#3	SAS3:Act	Act#7	SAS7:Act

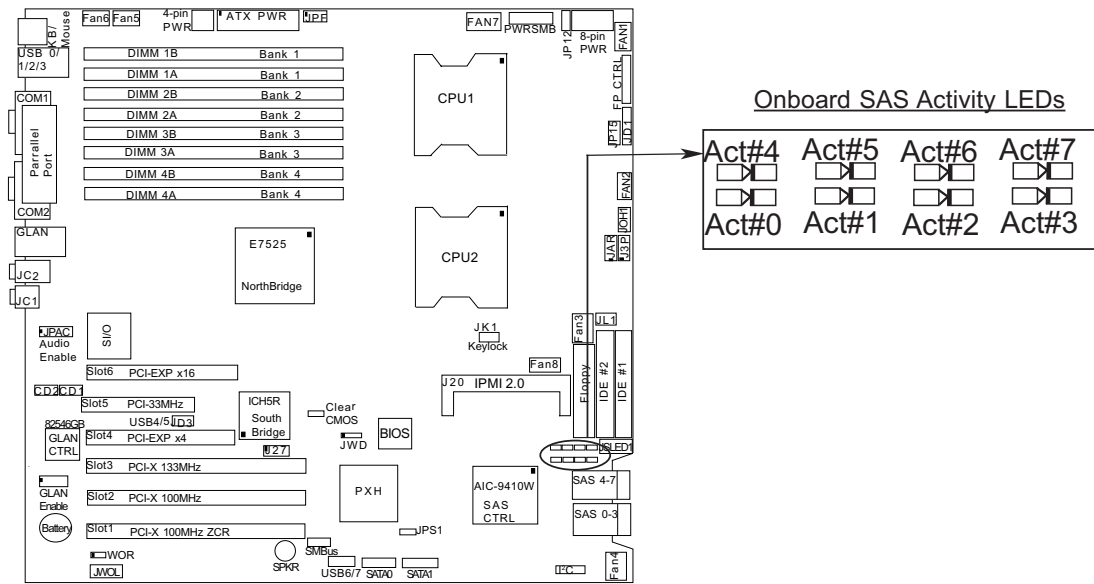

2-9 Parallel Port, Floppy Drive, Hard Disk Drive, IPMI 2.0 and SAS Connections

Note the following when connecting the floppy and hard disk drive cables:

- The floppy disk drive cable has seven twisted wires.
- A red mark on a wire typically designates the location of pin 1.
- A single floppy disk drive ribbon cable has 34 wires and two connectors to provide for two floppy disk drives. The connector with twisted wires always connects to drive A, and the connector that does not have twisted wires always connects to drive B.

Parallel (Printer) Port Connector

The parallel (printer) port is located on J23. See the table on the right for pin definitions.

Parallel (Printer) Port Connector Pin Definitions (J11)			
Pin#	Definition	Pin #	Definition
1	Strobe-	2	Auto Feed-
3	Data Bit 0	4	Error-
5	Data Bit 1	6	Init-
7	Data Bit 2	8	SLCT IN-
9	Data Bit 3	10	GND
11	Data Bit 4	12	GND
13	Data Bit 5	14	GND
15	Data Bit 6	16	GND
17	Data Bit 7	18	GND
19	ACK	20	GND
21	BUSY	22	Write Data
23	PE	24	Write Gate
25	SLCT	26	NC

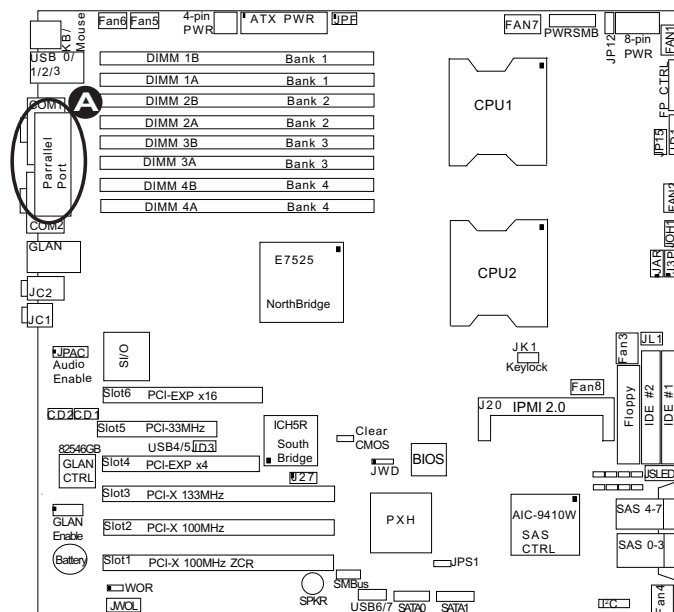

A. Parallel Port

Floppy Connector

The floppy connector is located on JP8. See the table below for pin definitions.

Floppy Drive Connector Pin Definitions (Floppy)			
Pin#	Definition	Pin #	Definition
1	Ground	2	FDHDIN
3	Ground	4	Reserved
5	Key	6	FDEDIN
7	Ground	8	Index
9	Ground	10	Motor Enable
11	Ground	12	Drive Select B
13	Ground	14	Drive Select B
15	Ground	16	Motor Enable
17	Ground	18	DIR
19	Ground	20	STEP
21	Ground	22	Write Data
23	Ground	24	Write Gate
25	Ground	26	Track 00
27	Ground	28	Write Protect
29	Ground	30	Read Data
31	Ground	32	Side 1 Select
33	Ground	34	Diskette

IPMI 2.0 Socket

There is an IPMI 2.0 Socket on the motherboard. Refer to the layout below for the IPMI Socket location.

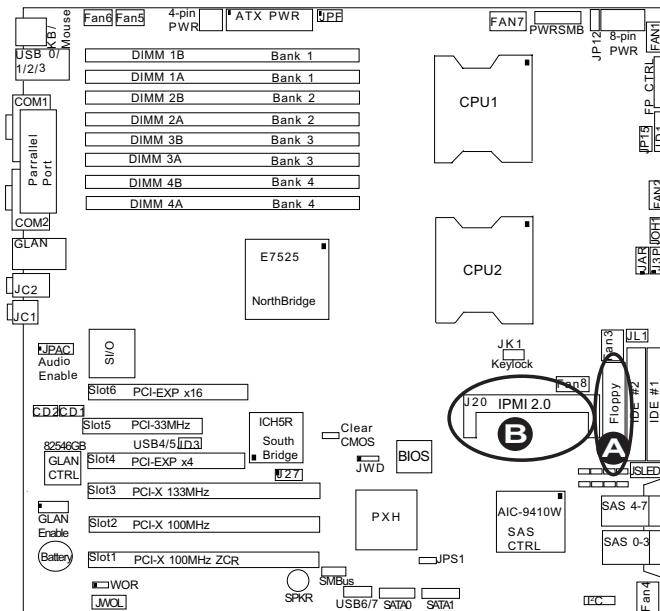

- A. Floppy
- B. IPMI 2.0

IDE Connectors

IDE#1 and IDE#2 connectors are located next to IPMI 2.0 Socket (at J3 and J4, respectively). See the table on the right for pin definitions.

IDE Drive Connectors Pin Definitions			
Pin#	Definition	Pin #	Definition
1	Reset IDE	2	Ground
3	Host Data 7	4	Host Data 8
5	Host Data 6	6	Host Data 9
7	Host Data 5	8	Host Data 10
9	Host Data 4	10	Host Data 11
11	Host Data 3	12	Host Data 12
13	Host Data 2	14	Host Data 13
15	Host Data 1	16	Host Data 14
17	Host Data 0	18	Host Data 15
19	Ground	20	Key
21	DRQ3	22	Ground
23	I/O Write	24	Ground
25	I/O Read	26	Ground
27	IOCHRDY	28	BALE
29	DACK3	30	Ground
31	IRQ14	32	IOCS16
33	Addr1	34	Ground
35	Addr0	36	Addr2
37	Chip Select 0	38	Chip Select 1
39	Activity	40	Ground

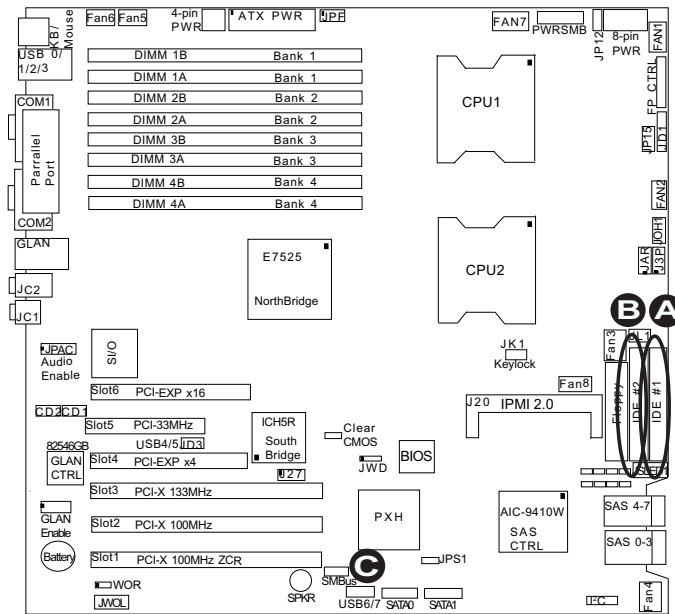

- A. IDE#1
- B. IDE#2

SAS Connectors (*X6DA3-G2 only)

There are eight Serial Attached SCSI (SAS0-3, SAS4-7) on the motherboard. See the tables on the right for pin definitions.

SAS Connector Pin Definitions			
Pin#	Definition	Pin #	Definition
A1	Ground	B1	Ground
A2	RX 0+	B2	TX 0+
A3	RX 0-	B3	TX 0-
A4	Ground	B4	Ground
A5	RX 1+	B5	TX 1+
A6	RX 1-	B6	TX 1-
A7	Ground	B7	Ground
A8	SB7	B8	SB0
A9	SB3	B9	SB1
A10	SB4	B10	SB2
A11	SB5	B11	SB6
A12	Ground	B12	Ground
A13	RX 2+	B13	TX 2+
A14	RX 2-	B14	TX 2-
A15	Ground	B15	Ground
A16	RX 3+	B16	TX 3+
A17	RX 3-	B17	TX 3-
A18	Ground	B18	Ground

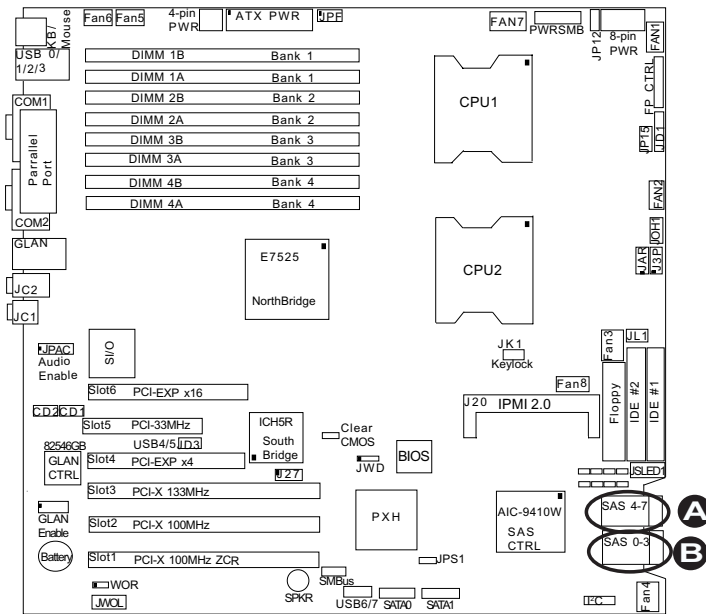

A. SAS 4-7

B. SAS 0-3

Chapter 3

Troubleshooting

3-1 Troubleshooting Procedures

Use the following procedures to troubleshoot your system. If you have followed all of the procedures below and still need assistance, refer to the 'Technical Support Procedures' and/or 'Returning Merchandise for Service' section(s) in this chapter.

Note: Always disconnect the power cord before adding, changing or installing any hardware components.

Before Power On

1. Make sure no short circuits exist between the motherboard and chassis.
2. Disconnect all ribbon/wire cables from the motherboard, including those for the keyboard and mouse.
3. Remove all add-on cards.
4. Install one CPU (making sure it is fully seated) and connect the chassis speaker and the power LED to the motherboard. (Check all jumper settings as well.)
5. Use the correct type of onboard CMOS battery as recommended by the Manufacturer. Do not install the onboard battery upside down to avoid possible explosion.

No Power

1. Make sure no short circuits exist between the motherboard and the chassis.
2. Verify that all jumpers are set to their default positions.
3. Check that the 115V/230V switch on the power supply is properly set.
4. Turn the power switch on and off to test the system.
5. The battery on your motherboard may be old. Check to verify that it still supplies ~3VDC. If it does not, replace it with a new one.

No Video

1. If the power is on but you have no video, remove all the add-on cards and cables.
2. Use the speaker to determine if any beep codes exist. Refer to the Appendix for details on beep codes.
3. Make sure that memory speeds and jumper settings are set correctly.

NOTE

If you are a system integrator, VAR or OEM, a POST diagnostics card is recommended. For I/O port 80h codes, refer to App. B.

Memory Errors

1. Make sure the DIMM modules are properly and fully installed.
2. Determine if different speeds of DIMMs have been installed and verify that the BIOS setup is configured for the fastest speed of RAM used. It is recommended to use the same RAM speed for all DIMMs in the system.
3. Make sure you are using the correct type of Registered, ECC DDRII 400 (PC3200) SDRAM (*recommended by the manufacturer.) (*Please refer to Chapter 2 for DDR memory support.)
4. Check for bad DIMM modules or slots by swapping a single module between two slots and noting the results.
5. Make sure all memory modules are fully seated in their slots. As an interleaved memory scheme is used, you must install two modules at a time, beginning with DIMM #1A, then DIMM #1B, and so on (see Section 2-3).

Losing the System's Setup Configuration

1. Make sure that you are using a high quality power supply. A poor quality power supply may cause the system to lose the CMOS setup information. Refer to Section 1-6 for details on recommended power supplies.
2. The battery on your motherboard may be old. Check to verify that it still supplies ~3VDC. If it does not, replace it with a new one.
3. If the above steps do not fix the Setup Configuration problem, contact your vendor for repairs.

3-2 Technical Support Procedures

Before contacting Technical Support, please take the following steps. Also, note that as a motherboard manufacturer, Super Micro does not sell directly to end-users, so it is best to first check with your distributor or reseller for troubleshooting services. They should know of any possible problem(s) with the specific system configuration that was sold to you.

1. Please go through the 'Troubleshooting Procedures' and 'Frequently Asked Question' (FAQ) sections in this chapter or see the FAQs on our web site (<http://www.supermicro.com/support/faqs/>) before contacting Technical Support.

2. BIOS upgrades can be downloaded from our web site at [\(http://www.supermicro.com/support/bios/\)](http://www.supermicro.com/support/bios/).

Note: *Not all BIOS can be flashed depending on the modifications to the boot block code.*

3. If you still cannot resolve the problem, include the following information when contacting Super Micro for technical support:

- Motherboard model and PCB revision number
- BIOS release date/version (this can be seen on the initial display when your system first boots up)
- System configuration

An example of a Technical Support form is on our web site at <http://www.supermicro.com/support/contact.cfm>.

4. Distributors: For immediate assistance, please have your account number ready when placing a call to our technical support department. We can be reached by e-mail at support@supermicro.com, by phone at: (408) 503-8000, option 2, or by fax at (408)503-8019.

3-3 Frequently Asked Questions

Question: What are the various types of memory that my motherboard can support?

Answer: The X6DA3-G2/X6DAi-G2 has eight 240-pin DIMM slots that support registered ECC DDR2 400 (PC3200) SDRAM modules. It is strongly recommended that you do not mix memory modules of different speeds and sizes. Please refer to Chapter 2 for instructions on memory support.

Question: How do I update my BIOS?

Answer: It is recommended that you **do not** upgrade your BIOS if you are experiencing no problems with your system. Updated BIOS files are located on our web site at <http://www.supermicro.com>. Please check our BIOS warning message and the information on how to update your BIOS on our web site. Also, check the current BIOS revision and make sure it is newer than your BIOS before downloading. (***Note:** There is no BIOS Recovery function available for the motherboard. Should a problem occur after you flash the BIOS, you will need to change the BIOS chip.)

Question: What's on the CD that came with my motherboard?

Answer: The supplied compact disc has quite a few drivers and programs that will greatly enhance your system. We recommend that you review the CD and install the applications you need. Applications on the CD include chipset drivers for Windows and security and audio drivers.

3-4 Returning Merchandise for Service

A receipt or copy of your invoice marked with the date of purchase is required before any warranty service will be rendered. You can obtain service by calling your vendor for a Returned Merchandise Authorization (RMA) number. When returning to the manufacturer, the RMA number should be prominently displayed on the outside of the shipping carton, and mailed prepaid or hand-carried. Shipping and handling charges will be applied for all orders that must be mailed when service is complete.

This warranty only covers normal consumer use and does not cover damages incurred in shipping or from failure due to the alteration, misuse, abuse or improper maintenance of products.

During the warranty period, contact your distributor first for any product problems.

Chapter 4

Phoenix BIOS

4-1 Introduction

This chapter describes the Phoenix BIOS™ Setup utility for the X6DA3-G2/X6DAi-G2. The Phoenix ROM BIOS is stored in a flash chip and can be easily upgraded using a floppy disk-based program.

Note: Due to periodic changes to the BIOS, some settings may have been added or deleted and might not yet be recorded in this manual. Please refer to the Manual Download area of the Supermicro web site <<http://www.supermicro.com>> for any changes to the BIOS that may not be reflected in this manual.

System BIOS

The BIOS is the Basic Input Output System used in all IBM® PC, XT™, AT®, and PS/2® compatible computers. The Phoenix BIOS flash chip stores the system parameters, types of disk drives, video displays, etc. in the CMOS. The CMOS memory requires very little electrical power. When the computer is turned off, a back-up battery provides power to the CMOS Memory in RTC Logic, enabling it to retain system parameters. Each time the computer is powered-on the computer is configured with the values stored in the CMOS Memory by the system BIOS, which gains control at boot-up.

How To Change the Configuration Data

The CMOS information that determines the system parameters may be changed by entering the BIOS Setup utility. This Setup utility can be accessed by pressing the <Delete> key at the appropriate time during system boot. (See below.)

Starting the Setup Utility

Normally, the only visible POST (Power On Self Test) routine is the memory test. As the memory is being tested, press the <Delete> key to enter the main menu of the BIOS Setup utility. From the main menu, you can access the other setup screens, such as the Security and Power menus. Beginning with Section 4-3, detailed descriptions are given for each parameter setting in the Setup utility.



Warning: Do not shut down or reset the system while updating BIOS to prevent possible boot failure.

4-2 Running Setup

**Default settings are in bold text unless otherwise noted.*

The BIOS setup options described in this section are selected by choosing the appropriate text from the main BIOS Setup screen. All displayed text is described in this section, although the screen display is often all you need to understand how to set the options (See the next page).

When you first power on the computer, the Phoenix BIOS™ is immediately activated.

While the BIOS is in control, the Setup program can be activated in one of two ways:

1. By pressing <Delete> immediately after turning the video on, or
2. When the message shown below appears briefly at the bottom of the screen during the POST (Power On Self-Test), press the <Delete> key to activate the main Setup menu:

Press the <Delete> key to enter Setup

4-3 Main BIOS Setup

All main Setup options are described in this section. The main BIOS Setup screen is displayed below.

Use the Up/Down arrow keys to move between the different settings in each menu. Use the Left/Right arrow keys to move between the different setup screens.

Press the <Esc> key to exit the CMOS Setup Menu or a submenu. The next section describes in detail how to navigate through the menus. Press <+> and <-> keys to change the value of a setting.

Items that use submenus are indicated with the ► icon. With the item highlighted, press the <Enter> key to access the submenu.

Main BIOS Setup Menu

PhoenixBIOS Setup – Copyright 1985–2004 Phoenix Technologies Ltd.				
Main	Advanced	Security	Boot	Exit
System Time:	[17:30:58]	Item Specific Help <Tab>, <Shift-Tab>, or <Enter> selects field.		
System Date:	[10-17-2005]			
BIOS Date				
Legacy Diskette A:	[1.44/1.25 MB 3½"]			
Parallel ATA:	[Both]			
Serial ATA:	[Enabled]			
SATA RAID Enable	[Disabled]			
Native Mode Operation:	[Auto]			
▶ IDE Channel 0 Master				
▶ IDE Channel 0 Slave				
▶ IDE Channel 1 Master				
▶ IDE Channel 1 Slave				
▶ IDE Channel 2 Master				
▶ IDE Channel 3 Master				
System Memory:	[XXXX KB]			
Extended Memory:	[XXXX KB]			
F1 Help ↑↓ Select Item -/+ Change Values F9 Setup Defaults Esc Exit ←→ Select Menu Enter Select ▶ Sub-Menu F10 Previous Values				

Main Setup Features

System Time

To set the system date and time, key in the correct information in the appropriate fields. Then press the <Enter> key to save the data.

System Date

Using the arrow keys, highlight the month, day, and year fields, and enter the correct data. Press the <Enter> key to save the data.

BIOS Date

This field displays the date when this version of BIOS was built.

Legacy Diskette A

This setting allows the user to set the type of floppy disk drive installed as diskette A. The options are Disabled, 360Kb 5.25 in, 1.2MB 5.25 in, 720Kb 3.5 in, **1.44/1.25MB**, 3.5 in, and 2.88MB 3.5 in.

Parallel ATA

This setting allows the user to enable or disable the function of Parallel ATA. The options are Disabled, Channel 0, Channel 1, and **Both**.

Serial ATA

This setting allows the user to enable or disable the function of Serial ATA. The options are Disabled and **Enabled**.

Serial ATA RAID Enable

Select Enable to enable Serial ATA RAID Functions. (*For the Windows OS environment, use the RAID driver if this feature is set to Enabled. If set to **Disabled**, use the Non-RAID driver.)

Native Mode Operation

Select the native mode for ATA. The options are: Parallel ATA, Serial ATA, Both, and **Auto**.

►IDE Channel 0 Master/Slave, IDE Channel 1 Master/Slave, IDE Channel 2 Master, IDE Channel 3 Master

These settings allow the user to set the parameters of IDE Channel 0 Master/Slave, IDE Channel 1 Master/Slave, IDE Channel 2 Master, IDE Channel 3 Master slots. Hit <Enter> to activate the following sub-menu screen for detailed options of these items. Set the correct configurations accordingly. The items included in the sub-menu are:

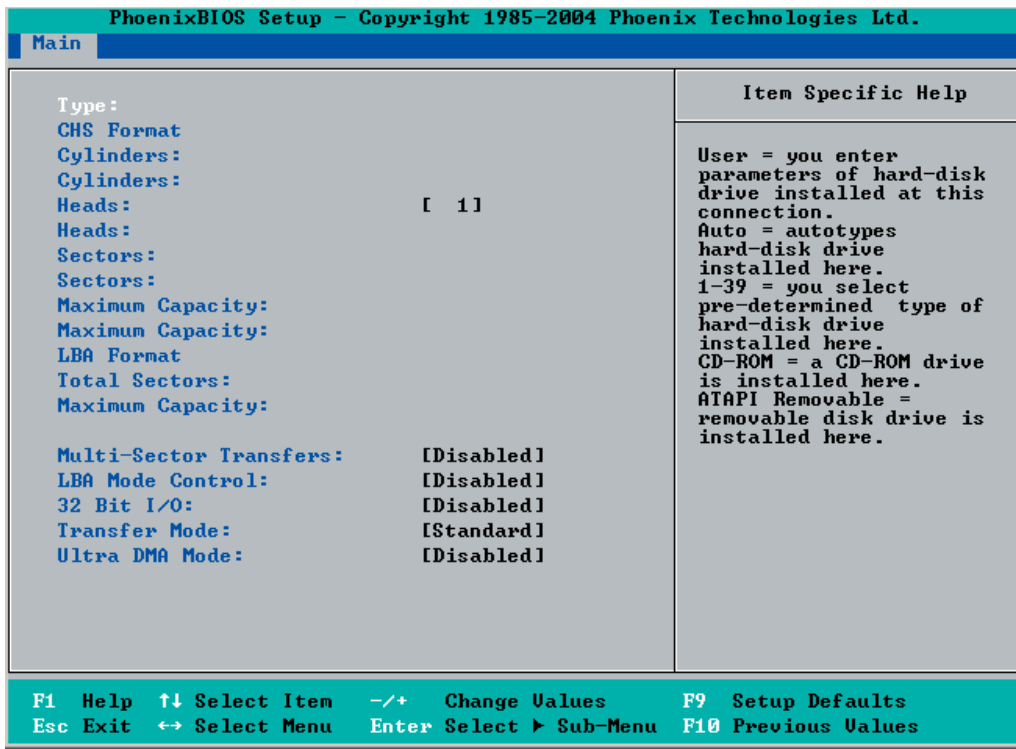

Type

Selects the type of IDE hard drive. The options are **Auto**, (which allows BIOS to automatically determine the hard drive's capacity, number of heads, etc.), a number from 1-39 to select a predetermined type of hard drive, CDROM and ATAPI Removable. The option "User" will allow the user to enter the parameters of the HDD installed at this connection. The option "Auto" will allow BIOS to automatically configure the parameters of the HDD installed at the connection. Choose the option 1-39 to select a predetermined HDD type. Select CDROM if a CDROM drive is installed. Select ATAPI if a removable disk drive is installed.

CHS Format

The following items will be displayed by the BIOS:

TYPE: This item displays the type of CPU.

Cylinders: This item indicates the status of Cylinders.

Headers: This item indicates the number of headers.

Sectors: This item displays the number of sectors.

Maximum Capacity: This item displays the maximum storage capacity of the system.

LBA Format

The following items will be displayed by the BIOS:

Total Sectors: This item displays the number of total sectors available in the LBA Format.

Maximum Capacity: This item displays the maximum capacity in the LBA Format.

Multi-Sector Transfer

This item allows the user to specify the number of sectors per block to be used in multi-sector transfer. The options are **Disabled**, 4 Sectors, 8 Sectors, and 16 Sectors.

LBA Mode Control

This item determines whether Phoenix BIOS will access the IDE Channel 0 Master Device via the LBA mode. The options are Enabled and **Disabled**.

32 Bit I/O

This option allows the user to enable or disable the function of 32-bit data transfer. The options are Enabled and **Disabled**.

Transfer Mode

This feature allows the user to select the transfer mode. The options are **Standard**, Fast PIO1, Fast PIO2, Fast PIO3, Fast PIO4, FPIO3/DMA1, and FPIO4/DMA2.

Ultra DMA (Direct Memory Access) Mode

This feature allows the user to select Ultra DMA Modes. DMA Modes allow peripheral devices (such as sound cards, floppy disks) to transfer data directly to and from the memory modules without going through the CPU. With double transition clocking, UDMA (Ultra DMA) allows data to be transferred on both rising and falling edges of the clock, doubling data throughput for any given clock speed. The options are Disabled, Mode 0, Mode 1, Mode 2, Mode 3, Mode 4, and Mode 5. Please refer to the table below for detailed information. Selects Ultra DMA Mode. The options are **Disabled**, Mode 0, Mode 1, Mode 2, Mode 3, Mode 4 and Mod5.

Ultra DMA Mode	Cycle Time (Nanoseconds)	Maximum Transfer Rate (MB/s)
Mode 0	240	16.7
Mode 1	160	25.0
Mode 2	120	33.3
Mode 3	90	44.4
Mode 4	60	66.7
Mode 5	40	100

System Memory

This display informs you how much system memory is recognized and detected in the system.

Extended Memory

This display informs you how much extended memory is recognized and detected in the system.

4-4 Advanced Setup

Choose Advanced from the Phoenix BIOS Setup Utility main menu with the arrow keys. You should see the following display. An item with a triangle beside it has a sub menu that can be accessed by highlighting the item and pressing <Enter>. Options for PIR settings are displayed by highlighting the setting option by using the arrow keys and pressing <Enter>. All Advanced BIOS Setup options are described in this section.

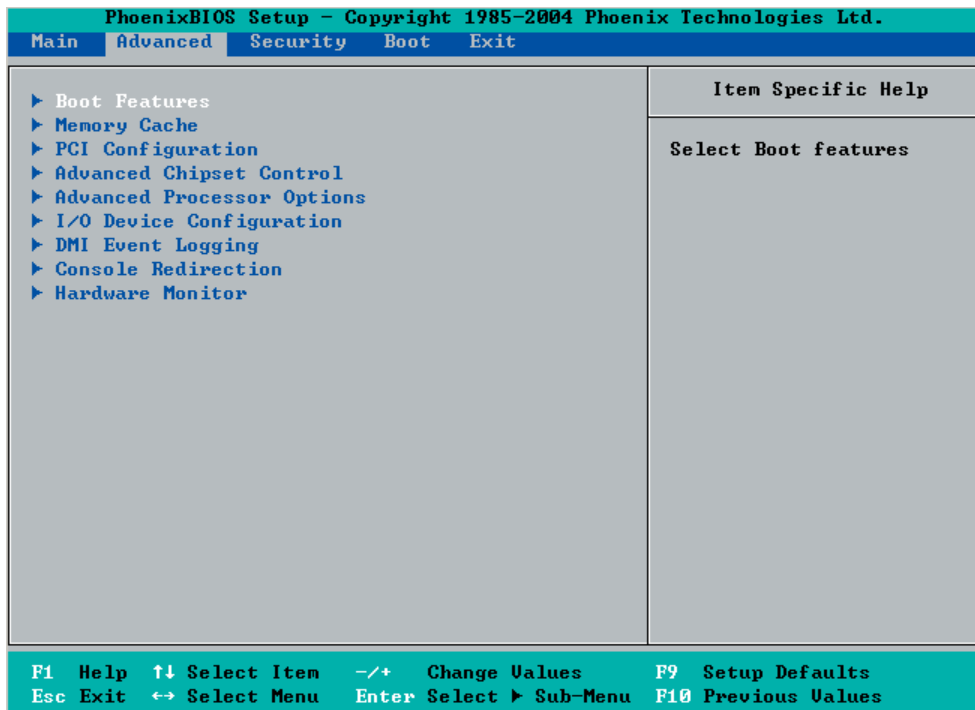

▶ Boot Features

Access the submenu to make changes to the following settings.

Quick Boot Mode

If enabled, this feature will speed up the POST (Power On Self Test) routine by skipping certain tests after the computer is turned on. The settings are **Enabled** and Disabled. If Disabled, the POST routine will run at the normal speed.

Quiet Boot

When Enabled, the system will switch to the graphic mode and display OEM's logo during boot-up. The system will automatically switch to the text mode if an error occurs. The settings are **Enabled** and Disabled.

ACPI Mode

Use this setting to determine if you want to employ ACPI (Advanced Configuration and Power Interface) power management on your system. The options are **Yes** and No.

ACPI Sleep Mode

This option allows you to select the sleep mode for ACPI. The options are **S1(-Stanby)** and **S3 (-Suspend to RAM)**.

Power Button Behavior

This setting allows you to choose how the system powers down when the user presses the power button. Select Instant-Off to power off the system as soon as the power button is pressed. Select 4-sec override to allow the system to wait for 4 seconds before power-off when the power button is pressed. The options are **Instant-Off** and 4-sec override.

Resume On Modem Ring

Select On to “wake your system up” when an incoming call is received by your modem. The options are On and **Off**.

Keyboard on Now Function

This option allows you to select how the system may be resumed from the S3-S5 state. The options are Space (by pressing the sapce bar), Password (by entering a password), and **Disabled**.

Set Power On Password

Enter up to 5 digits of letters and numbers to set a Power On Password to allow the user to power on the system.

Power Loss Control

This setting allows you to choose how the system will react when power returns after an unexpected loss of power. The options are Stay Off, Power On and **Last State**.

Watch Dog

This setting is for enabling the Watch Dog feature. The The options are Enabled and **Disabled**.

Summary Screen

This setting allows you to **Enable** or Disable the summary screen which displays the system configuration during bootup.

► Memory Cache

Cache System BIOS Area

This setting allows you to designate a reserve area in the system memory to be used as a System BIOS buffer to allow the BIOS to write (cache) its data into this reserved memory area. Select "**Write Protect**" to enable this function, and this area will be reserved for the BIOS ROM access only. Select "Uncached" to disable this function and make this area available for other devices.

Cache Video BIOS Area

This setting allows you to designate a reserve area in the system memory to be used as a Video BIOS buffer to allow the BIOS to write (cache) its data into this reserved memory area. Select "**Write Protect**" to enable the function and this area will be reserved for the BIOS ROM access only. Select "Uncached" to disable this function and make this area available for other devices.

Cache Base 0-512K

If enabled, this feature will allow the data stored in the base memory area of Block 0-512K to be cached (written) into the system memory or into L1, L2, L3 cache area inside the CPU to speed up CPU operations. Select "Uncached" to disable this function. Select "Write Through" to allow data to be cached into the system memory and into L1, L2, L3 cache area of the CPU at the same time. Select "Write Protect" to prevent data from being cached into the system memory area of Block 0-512K. Select "Write Back" to allow CPU to write data back directly from the L1, L2, L3 cache inside the CPU without writing data to the System Memory for fast CPU data processing and operation. The options are "Uncached", "Write Through", "Write Protect", and "**Write Back**".

Cache Base 512K-640K

If enabled, this feature will allow the data cached in the memory area of Block 512K-640K or to into L1, L2, L3 cache inside the CPU to speed up CPU operations. Select "Uncached" to disable this function. Select "Write Through" to allow data to be cached into the CPU L1, L2, L3 cache area and into the system memory at the same time. Select "Write Protect" to prevent data from being written into the base memory area of Block 512K-640K. Select "Write Back" to allow CPU to write data back directly from L1, L2, L3 Cache area inside the CPU without writing data to the System Memory for fast CPU data processing and operation. The options are "Uncached", "Write Through", "Write Protect", and "**Write Back**".

Cache Extended Memory

If enabled, this feature will allow the data cached in the system memory area above 1 MB or to be cached into L1, L2, L3 cache inside the CPU to speed up CPU operations. Select "Uncached" to disable this function. Select "Write Through" to allow data to be cached into the system memory and into L1, L2, L3 cache area in the CPU at the same time. Select "Write Protect" to prevent data from being written into the system memory above 1MB. Select "Write Back" to allow the CPU to write data back directly from L1, L2, L3 Cache area inside the CPU without writing data to the System Memory for fast CPU data processing and operation. The options are "Uncached", "Write Through", "Write Protect", and "**Write Back**".

Discrete MTRR Allocation

If enabled, MTRRs (-Memory Type Range Registers) are configured as distinct, separate units and cannot be overlapped. If enabled, the user can achieve better graphic effects when using a Linux graphic driver that requires the write-combining configuration with 4GB or more memory. The options are Enabled and **Disabled**.

► PCI Configuration

Access the submenu to make changes to the following settings for PCI devices.

Onboard GLAN (Gigabit- LAN) OPROM Configure

Enabling this option provides the capability to boot from GLAN. The options are Enabled and **Disabled**.

Onboard SCSI OPROM Configure

Enabling this option provides the capability to boot from SCSI HDD. The options are Disabled and **Enabled**.

Default Primary Video Adapter

This item allows the user to select the Primary Video Adapter between two adapters instead of selecting among three or more adapters. The options are Other and **Onboard Video**.

PCI Parity Error Forwarding

Enable this item to forward the PCI errors occurring behind P2P bridges to South Bridge, so NMI can be asserted. The options are Enabled and **Disabled**.

ROM Scan Ordering

This feature allows the user to decide which Option ROM to be activated first. The options are **Onboard Option ROM first** and the Add-On Option ROM first.

Reset Configuration Data

If set to Yes, this setting clears the Extended System Configuration Data- (ESCD) area. The options are Yes and **No**.

Frequency for PCIX#1-#2/MASS (*Note: MASS=Mass Storage Devices: SATA, SAS and SCSI. SAS is available on the X6DA3-G2 only.

This option allows the user to change the bus frequency for the devices installed in the slot indicated. The options are **Auto**, PCI 66 MHz, PCI-X 66 MHz, PCI-X 100 MHz, and PCI-X 133 MHz.

Frequency for PCIX#3/G-LAN

This option allows the user to change the bus frequency of the devices installed in the slot indicated. The options are **Auto**, PCI 66 MHz, PCI-X 66 MHz, PCI-X 100 MHz, and PCI-X 133 MHz.

Frequency for PCI-X#1 On Riser, Frequency for PCI-X#2-#3 On Riser (*Available when a 2U Active Riser Card is present.

This option allows the user to change the bus frequency of the devices installed in the slot indicated. The options are **Auto**, PCI 33 MHz, PCI 66 MHz, PCI-X 66 MHz, PCI-X 100 MHz, and PCI-X 133 MHz.

► PCI-X 100MHz ZCR Slot#1/PCI-X 100MHz Slot#2/PCI-X 133MHz Slot#3/PCI-E X4 Slot#4/PCI 33MHz Slot#5/PCI-E X16 Slot#6

Access the submenu for each of the settings above to make changes to the following:

Option ROM Scan

When enabled, this setting will initialize the device expansion ROM. The options are **Enabled** and Disabled.

Enable Master

This setting allows you to enable the selected device as the PCI bus master. The options are **Enabled** and Disabled.

Latency Timer

This setting allows you to set the clock rate for Bus Master. A high-priority, high-throughput device may benefit from a greater Clock rate. The options are **Default**, 0020h, 0040h, 0060h, 0080h, 00A0h, 00C0h, and 00E0h. For Unix, Novell and other Operating Systems, please select the option:"Other". If a drive fails after the installation of a new software, you might want to change this setting and try again. Different OS requires different Bus Master clock rate.

Large Disk Access Mode

This setting determines how large hard drives are to be accessed. The options are **DOS** or Other (for Unix, Novell NetWare and other operating systems).

► Advanced Chipset Control

Access the submenu to make changes to the following settings.

Force Compliance Mode Entry

If enabled, this feature sets the device specified to comply with the PCI-Express Compliance 1.0 Mode. The options are: **Disabled** and **Enabled**.

Memory RAS Feature Control

Select this option to enable Memory RAS (Reliability/ Availability/Serviceability) Feature Control. The Options are **Standard**, **Sparing**, and **Mirroring**. Select **Sparing** (RAID 0) to increase the performance of data transfer by simultaneously writing data to two drives. Select **Mirroring** (RAID 1) to increase data protection by writing identical data on two drives.

Clock Spectrum Feature

If "Enabled", BIOS will sensor and attempt to reduce the Electromagnetic Interference caused by the components. The options are **Enabled** and **Disabled**.

Memory Remap Function Control

PCI memory resources will overlap with the physical memory if 4GB of memory or above is installed on the motherboard. When this occurs, **enable** this function to reallocate the overlapped physical memory to a location above 4GB to resolve the memory overlapping situation.

Delayed Transaction Discard

Select **Disabled** to set the ESB P2P Bridge Secondary Discard Timer to 32 micro-seconds for the PCI-32 bus. Select **Enabled** to set the ESB P2P Bridge Secondary Discard Timer to 4 micro-seconds for the PCI-32 bus.

DRAM Data Integrity Mode

If enabled, this feature allows the data stored in the DRMA memory to be integrated for faster data processing. The options are **72-bit ECC**, **144-bit ECC**, **Auto** and **Disabled**.

ECC Error Type

This setting lets you select which type of interrupt to be activated as a result of an ECC error. The options are **None**, **NMI** (Non-Maskable Interrupt), **SMI** (System Management Interrupt) and **SCI** (System Control Interrupt.)

SERR (System Error) Signal Condition

This setting specifies the conditions required to be qualified as an ECC error. The options are **None**, **Single Bit**, **Multiple Bit** and **Both**.

Enabling Multi-Media Timer

Select Yes to activate a set of timers that are alternative to the traditional 8254 timers for the OS use. The options are Yes and **No**.

USB Function

This setting allows you to **Enable** or Disable all functions for the USB devices specified.

Legacy USB Support

This setting allows you to enable support for Legacy USB devices. The settings are **Enabled** and Disabled.

► Advanced Processor Options

Access the submenu to make changes to the following settings.

CPU Speed

This is a display that indicates the speed of the installed processor.

Hyper-threading (*Available when supported by the CPU.)

Set to Enabled to use the Hyper-Threading Technology, which will result in increased CPU performance. The options are Disabled or **Enabled**.

Machine Checking (*Available when supported by the CPU.)

Set to Enabled to activate the function of Machine Checking and allow the CPU to detect and report hardware (machine) errors via a set of model-specific registers (MSRs). The options are Disabled or **Enabled**.

C1 Enhanced Mode (*Available when supported by the CPU.)

Set to Enabled to enable Enhanced Halt State to lower CPU voltage/frequency to prevent overheat. The options are Enabled and **Disabled**. (***Note:** please refer to Intel's web site for detailed information.)

No Execute Mode Memory Protection (*Available when supported by the CPU and the OS.)

Set to **Enabled** to enable Execute Disable Bit and allow the processor to classify areas in memory where an application code can execute and where it can not, and thus, preventing a worm or a virus from inserting and creating a flood of codes to overwhelm the processor or damage the system during an attack. (***Note:** this feature is available when your OS and your CPU support the function of Execute Disable Bit.) The options are Disabled and **Enabled**. (Note: For more information regarding hardware/software support for this function, please refer to Intel's and Microsoft's web sites.)

Thermal Management 2 (*Available when supported by the CPU.)

Set to Enabled to use Thermal Management 2 (TM2) which will lower CPU voltage and frequency when the CPU temperature reaches a pre-defined overheat threshold. Set to **Disabled** to use Thermal Manager 1 (TM1), allowing CPU clocking to be regulated via CPU Internal Clock modulation when the CPU temperature reaches the overheat threshold.

Adjacent Cache Line Prefetch (*Available when supported by the CPU.)

The CPU fetches the cache line for 64 bytes if this option is set to Disabled. The CPU fetches both cache lines for 128 bytes as comprised if Enabled. The options are Disabled and **Enabled**.

Processor Power Management

This feature allows the user to determine the processor power management mode. The options are **Disabled** and C States Only. If set to Disabled, C States and GV1/GV3 are disabled. If set to C States only, the processor power will be controlled through CPU power states in the APCI setting.

► I/O Device Configuration

Access the submenu to make changes to the following settings.

KBC Clock input

This setting allows you to set the clock frequency for the Keyboard Clock. The options are 6MHz, 8MHz, and **12 MHz**.

Onboard COM1

This setting allows you to assign control of serial port A. The options are **Enabled** (user defined), Disabled, Auto (BIOS controlled) and OS Controlled.

Base I/O Address

This setting allows you to select the base I/O address for serial port A. The options are **3F8**, 2F8, 3E8 and 2E8.

Interrupt

This setting allows you to select the IRQ (interrupt request) for the parallel port. The options are IRQ3 and **IRQ4**.

Onboard COM2

This setting allows you to assign control of serial port B. The options are **Enabled** (user defined), Disabled, Auto (BIOS controlled) and OS Controlled.

Mode

This setting allows you to specify the type of device that will be connected to serial port B. The options are **Normal**, IR (for an infrared device) and ASK-IR.

Base I/O Address

This setting allows you to select the base I/O address for serial port B. The options are 3F8, **2F8**, 3E8 and 2E8.

Interrupt

This setting allows you to select the IRQ (interrupt request) for the parallel port. The options are **IRQ3** and IRQ4.

Parallel Port

This setting allows you to assign control of the parallel port. The options are **Enabled** (user defined), Disabled and Auto (BIOS controlled).

Base I/O Address

This setting allows you to select the base I/O address for the parallel port. The options are **378**, 278 and 3BC.

Interrupt

This setting allows you to select the IRQ (interrupt request) for the parallel port. The options are IRQ5 and **IRQ7**.

Mode

This setting allows you to specify the parallel port mode. The options are Output, Bi-directional, **ECP** and EPP.

DMA Channel

This setting allows you to specify the DMA channel mode. The options are DMA1 and **DMA3**.

Floppy Disk Controller

This setting allows you to assign control of the floppy disk controller. The options are **Enabled** (user defined), Disabled, Auto (BIOS controlled) and OS Controlled.

Base I/O Address

This setting allows you to select the base I/O address for the Floppy port. The options are **Primary** and Secondary.

► Console Redirection

Access the submenu to make changes to the following settings.

COM Port Address

This setting allows you to specify the port you want to redirect the console to: On-board COM A or On-board COM B. This setting can also be **Disabled**.

BAUD Rate

This setting allows you to select the BAUD rate for console redirection. The options are 300, 1200, 2400, 9600, **19.2K**, 38.4K, 57.6K and 115.2K.

Console Type

This setting allows you to choose from the available options to select the console type for console redirection. The options are VT100, VT100,8bit, PC-ANSI, 7bit, **PC ANSI**, VT100+, VT-UTF8.

Flow Control

This setting allows you to choose from the available options to select the flow control for console redirection. The options are: None, XON/XOFF, and **CTS/RTS**.

Console Connection

This feature allows you to select the console connection: either **Direct** or Via Modem.

Continue CR after POST

This feature allows you to choose whether to continue with console redirection after the POST routine. The options are On and **Off**.

► DMI Event Logging

Access the submenu to make changes to the following settings.

Event Log Validity

This is a display, not a setting, informing you of the event log validity.

Event Log Capacity

This is a display, not a setting, informing you of the event log capacity.

View DMI Event Log

Highlight this item and press <Enter> to view the contents of the event log.

Event Logging

This setting allows you to **Enable** or Disable event logging.

ECC Event Logging

This setting allows you to **Enable** or Disable ECC event logging.

Mark DMI Events as Read

Highlight this item and press <Enter> to mark the DMI events as read.

Clear All DMI Event Logs

Select Yes and press <Enter> to clear all DMI event logs.

► Hardware Monitor Logic

CPU Temperature Threshold

This option allows the user to set a CPU temperature threshold that will activate the alarm system when the CPU temperature reaches this pre-set temperature threshold. The options are 70°C, **75°C**, 80°C and 85°C.

Highlight this and hit <Enter> to see monitor data for the following items:

CPU1 Temperature: This item displays CPU1 Temperature.

CPU2 Temperature: This item displays CPU2 Temperature.

System Temperature: This item displays the System Temperature.

Fan Speed Control Modes

This feature allows the user to decide how the system controls the speeds of the onboard fans. The CPU temperature and the fan speed are correlative. When the CPU on-die temperature increases, the fan speed will also increase, and vice versa. If the option is set to “3-pin fan”, the fan speed is controlled by voltage. If the option is set to “4-pin”, the fan speed will be controlled by Pulse Width Modulation (PWM). Select “3-pin” if your chassis came with 3-pin fan headers. Select “4-pin” if your chassis came with 4-pin fan headers. Select “Workstation” if your system is used as a Workstation. Select “Server” if your system is used as a Server. Select “Disable” to disable the fan speed control function to allow the onboard fans to run at the full speed (12V) at all the time. The Options are: **1. Disable**, 2. 3-pin (Server), 3. 3-pin (Workstation), 4. 4-pin (Server) and 5. 4-pin (Workstation).

Fan 1 to Fan 6 (chassis fans), Fan 7 (CPU Fan 1), Fan 8 (CPU Fan2): If the feature of Auto Fan Control is enabled, BIOS will automatically display the status of the fans indicated in this item.

Vcore A/Vcore B: These items display the Voltage status of CPU A and CPU B.

P3V3: This item displays the +3.3V voltage status.

P5V: This item displays the +5V voltage status.

N12V: This item displays the -12V voltage status.

P12V: This item displays the +12V voltage status.

VDD: This item displays the VDD status.

P5Vsb: This item displays the voltage status of +5V Standby power.

P3P3Vsb: This item displays the voltage status of +3.3V Standby power.

4-5 Security

Choose Security from the Phoenix BIOS Setup Utility main menu with the arrow keys. You should see the following display. Security setting options are displayed by highlighting the setting using the arrow keys and pressing <Enter>. All Security BIOS settings are described in this section.

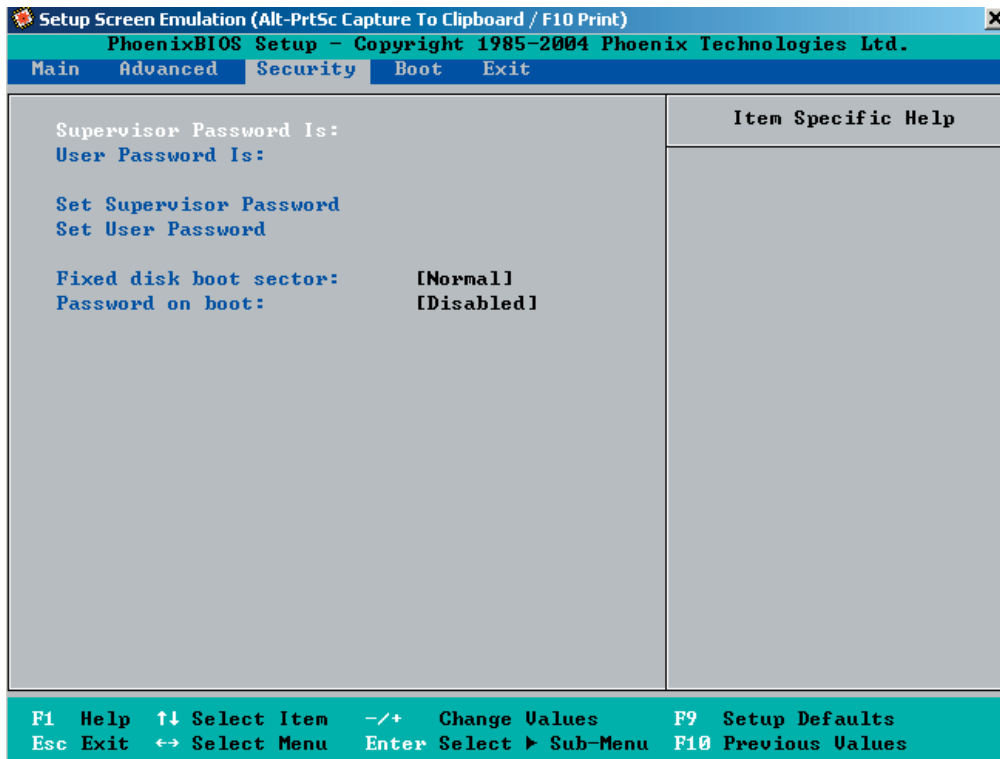

Supervisor Password Is:

This displays whether a supervisor password has been entered for the system. Clear means such a password has not been used and Set means a supervisor password has been entered for the system.

User Password Is:

This displays whether a user password has been entered for the system. Clear means such a password has not been used and Set means a user password has been entered for the system.

Set Supervisor Password

When the item "Set Supervisor Password" is highlighted, hit the <Enter> key. When prompted, type the Supervisor's password in the dialogue box to set or to change supervisor's password, which allows access to the BIOS.

Set User Password

When the item "Set User Password" is highlighted, hit the <Enter> key. When prompted, type the user's password in the dialogue box to set or to change the user's password, which allows access to the system at boot-up.

Fixed Disk Boot Sector

This setting may offer some protection against viruses when set to Write Protect, which protects the boot sector on the hard drive from having a virus written to it. The other option is **Normal**.

Password on Boot

This setting allows you to require a password to be entered when the system boots up. The options are Enabled (password required) and Disabled (password not required).

4-6 Boot

Choose Boot from the Phoenix BIOS Setup Utility main menu with the arrow keys. You should see the following display. Highlighting a setting with a + or - will expand or collapse that entry. See details on how to change the order and specs of boot devices in the Item Specific Help window. All Boot BIOS settings are described in this section.

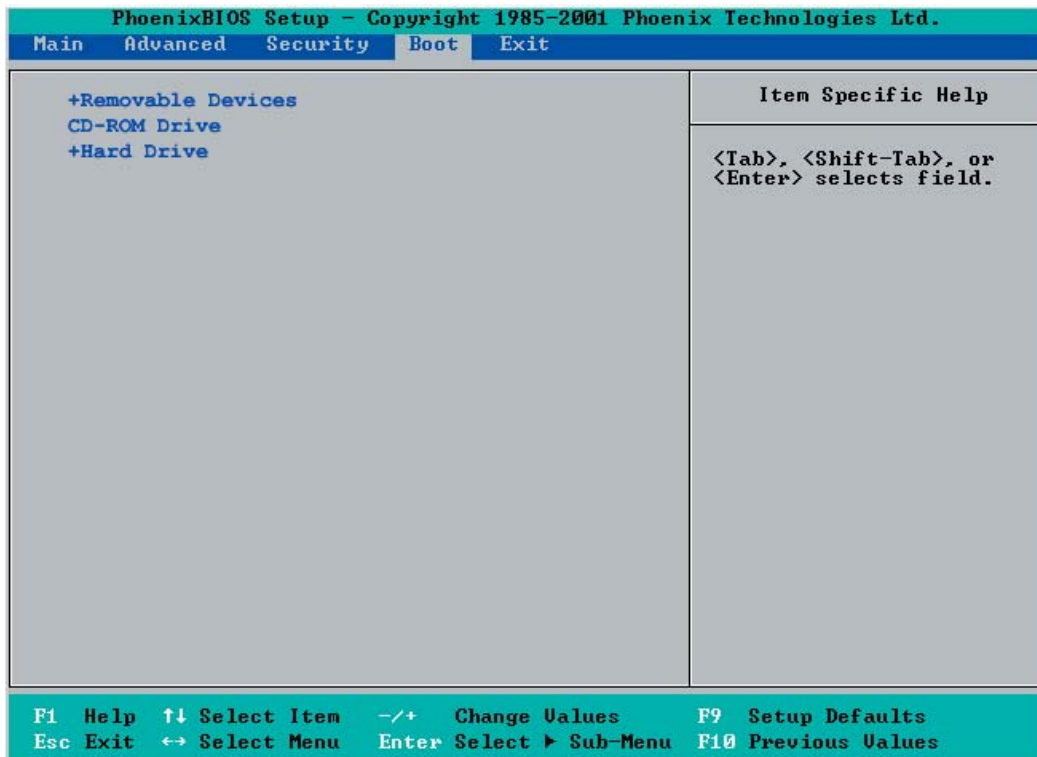

+Removable Devices

Highlight and press <Enter> to expand the field. See details on how to change the order and specs of devices in the Item Specific Help window.

CD-ROM Drive

See details on how to change the order and specs of the CD-ROM drive in the Item Specific Help window.

+Hard Drive

Highlight and press <Enter> to expand the field. See details on how to change the order and specs of hard drives in the Item Specific Help window.

4-7 Exit

Choose Exit from the Phoenix BIOS Setup Utility main menu with the arrow keys. You should see the following display. All Exit BIOS settings are described in this section.

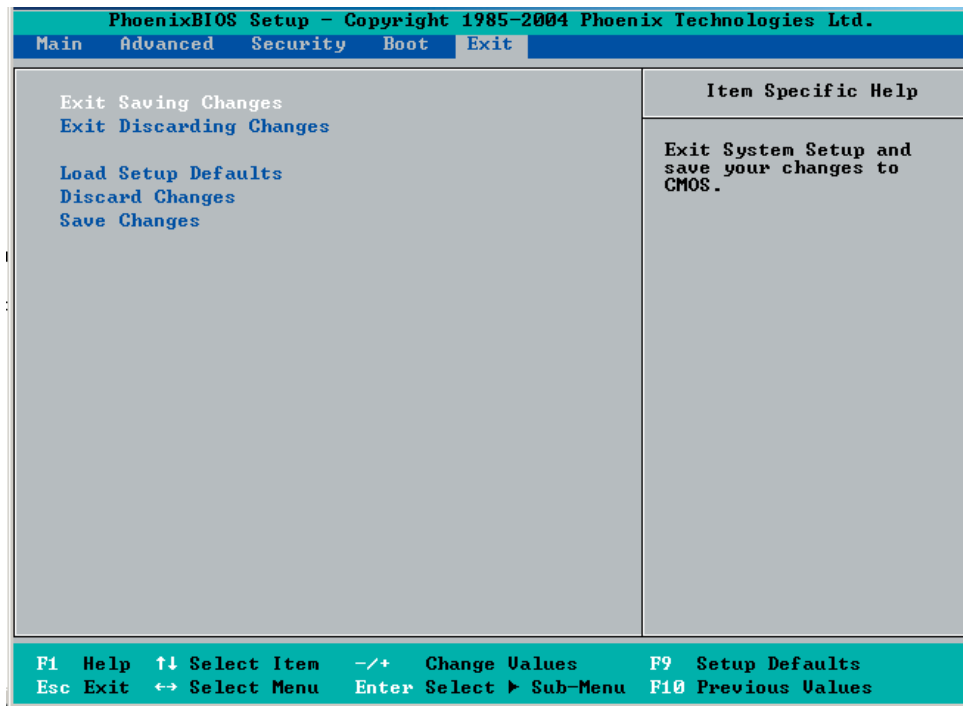

Exit Saving Changes

Highlight this item and hit <Enter> to save any changes you made and to exit the BIOS Setup utility.

Exit Discarding Changes

Highlight this item and hit <Enter> to exit the BIOS Setup utility without saving any changes you may have made.

Load Setup Defaults

Highlight this item and hit <Enter> to load the default settings for all items in the BIOS Setup. These are the safest settings to use.

Discard Changes

Highlight this item and hit <Enter> to discard (cancel) any changes you made. You will remain in the Setup utility.

Save Changes

Highlight this item and hit <Enter> to save any changes you made. You will remain in the Setup utility.

Appendix A

BIOS POST Error Messages

During the Power-On Self-Test (POST), the BIOS will check for problems. If a problem is found, the BIOS will activate an alarm or display a message. The following is a list of such BIOS messages.

Failure Fixed Disk

Fixed disk is not working or not configured properly. Check to see if fixed disk is attached properly. Run Setup. Find out if the fixed-disk type is correctly identified.

Stuck key

Stuck key on keyboard.

Keyboard error

Keyboard not working.

Keyboard Controller Failed

Keyboard controller failed test. May require replacing keyboard controller.

Keyboard locked - Unlock key switch

Unlock the system to proceed.

Monitor type does not match CMOS - Run SETUP

Monitor type not correctly identified in Setup

Shadow Ram Failed at offset: nnnn

Shadow RAM failed at offset **nnnn** of the 64k block at which the error was detected.

System RAM Failed at offset: nnnn

System RAM failed at offset **nnnn** of in the 64k block at which the error was detected.

Extended RAM Failed at offset: nnnn Extended memory not working or not configured properly at offset **nnnn**.

System battery is dead - Replace and run SETUP

The CMOS clock battery indicator shows the battery is dead. Replace the battery and run Setup to reconfigure the system.

System CMOS checksum bad - Default configuration used

System CMOS has been corrupted or modified incorrectly, perhaps by an application program that changes data stored in CMOS. The BIOS installed Default Setup Values. If you do not want these values, enter Setup and enter your own values. If the error persists, check the system battery or contact your dealer.

System timer error

The timer test failed. Requires repair of system board.

Real time clock error

Real-Time Clock fails BIOS hardware test. May require board repair.

Check date and time settings

BIOS found date or time out of range and reset the Real-Time Clock. May require setting legal date (1991-2099).

Previous boot incomplete - Default configuration used

Previous POST did not complete successfully. POST loads default values and offers to run Setup. If the failure was caused by incorrect values and they are not corrected, the next boot will likely fail. On systems with control of **wait states**, improper Setup settings can also terminate POST and cause this error on the next boot. Run Setup and verify that the waitstate configuration is correct. This error is cleared the next time the system is booted.

Memory Size found by POST differed from CMOS

Memory size found by POST differed from CMOS.

Diskette drive A error

Diskette drive B error

Drive A: or B: is present but fails the BIOS POST diskette tests. Check to see that the drive is defined with the proper diskette type in Setup and that the diskette drive is attached correctly.

Incorrect Drive A type - run SETUP

Type of floppy drive A: not correctly identified in Setup.

Incorrect Drive B type - run SETUP

Type of floppy drive B: not correctly identified in Setup.

System cache error - Cache disabled

RAM cache failed and BIOS disabled the cache. On older boards, check the cache jumpers. You may have to replace the cache. See your dealer. A disabled cache slows system performance considerably.

CPU ID:

CPU socket number for Multi-Processor error.

EISA CMOS not writeable

ServerBIOS2 test error: Cannot write to EISA CMOS.

DMA Test Failed

ServerBIOS2 test error: Cannot write to extended **DMA** (Direct Memory Access) registers.

Software NMI Failed

ServerBIOS2 test error: Cannot generate software NMI (Non-Maskable Interrupt).

Fail-Safe Timer NMI Failed

ServerBIOS2 test error: Fail-Safe Timer takes too long.

device Address Conflict

Address conflict for specified **device**.

Allocation Error for: device

Run ISA or EISA Configuration Utility to resolve resource conflict for the specified **device**.

CD ROM Drive

CD ROM Drive identified.

Entering SETUP ...

Starting Setup program

Failing Bits: nnnn

The hex number **nnnn** is a map of the bits at the RAM address which failed the memory test. Each 1 (one) in the map indicates a failed bit. See errors 230, 231, or 232 above for offset address of the failure in System, Extended, or Shadow memory.

Fixed Disk n

Fixed disk n (0-3) identified.

Invalid System Configuration Data

Problem with NVRAM (CMOS) data.

I/O device IRQ conflict

I/O device IRQ conflict error.

PS/2 Mouse Boot Summary Screen:

PS/2 Mouse installed.

nnnn kB Extended RAM Passed

Where nnnn is the amount of RAM in kilobytes successfully tested.

nnnn Cache SRAM Passed

Where nnnn is the amount of system cache in kilobytes successfully tested.

nnnn kB Shadow RAM Passed

Where nnnn is the amount of shadow RAM in kilobytes successfully tested.

nnnn kB System RAM Passed

Where nnnn is the amount of system RAM in kilobytes successfully tested.

One or more I2O Block Storage Devices were excluded from the Setup Boot Menu

There was not enough room in the IPL table to display all installed I2O block-storage devices.

Operating system not found

Operating system cannot be located on either drive A: or drive C:. Enter Setup and see if fixed disk and drive A: are properly identified.

Parity Check 1 nnnn

Parity error found in the system bus. BIOS attempts to locate the address and display it on the screen. If it cannot locate the address, it displays ?????. Parity is a method for checking errors in binary data. A parity error indicates that some data has been corrupted.

Parity Check 2 nnnn

Parity error found in the I/O bus. BIOS attempts to locate the address and display it on the screen. If it cannot locate the address, it displays **????**.

Press <F1> to resume, <F2> to Setup, <F3> for previous

Displayed after any recoverable error message. Press <F1> to start the boot process or <F2> to enter Setup and change the settings. Press <F3> to display the previous screen (usually an initialization error of an **Option ROM**, i.e., an add-on card). Write down and follow the information shown on the screen.

Press <F2> to enter Setup

Optional message displayed during POST. Can be turned off in Setup.

PS/2 Mouse:

PS/2 mouse identified.

Run the I2O Configuration Utility

One or more unclaimed block storage devices have the Configuration Request bit set in the LCT. Run an I2O Configuration Utility (e.g. the SAC utility).

System BIOS shadowed

System BIOS copied to shadow RAM.

UMB upper limit segment address: nnnn

Displays the address *nnnn* of the upper limit of **Upper Memory Blocks**, indicating released segments of the BIOS which can be reclaimed by a virtual memory manager.

Video BIOS shadowed

Video BIOS successfully copied to shadow RAM.

Notes

Appendix B

BIOS POST Codes

This section lists the POST (Power On Self Test) codes for the PhoenixBIOS. POST codes are divided into two categories: recoverable and terminal.

Recoverable POST Errors

When a recoverable type of error occurs during POST, the BIOS will display an POST code that describes the problem. BIOS may also issue one of the following beep codes:

1 long and two short beeps - video configuration error

1 repetitive beep - no memory detected

Terminal POST Errors

If a terminal type of error occurs, BIOS will shut down the system. Before doing so, BIOS will write the error to port 80h.

The following is a list of codes that may be written to port 80h.

POST Code	Description
02h	Verify Real Mode
03h	Disable Non-Maskable Interrupt (NMI)
04h	Get CPU type
06h	Initialize system hardware
07h	Disable shadow and execute code from the ROM.
08h	Initialize chipset with initial POST values
09h	Set IN POST flag
0Ah	Initialize CPU registers
0Bh	Enable CPU cache
0Ch	Initialize caches to initial POST values
0Eh	Initialize I/O component
0Fh	Initialize the local bus IDE
10h	Initialize Power Management
11h	Load alternate registers with initial POST values
12h	Restore CPU control word during warm boot
13h	Initialize PCI Bus Mastering devices
14h	Initialize keyboard controller
16h	1-2-2-3 BIOS ROM checksum
17h	Initialize cache before memory Auto size

POST Code	Description
18h	8254 timer initialization
1Ah	8237 DMA controller initialization
1Ch	Reset Programmable Interrupt Controller
20h	1-3-1-1 Test DRAM refresh
22h	1-3-1-3 Test 8742 Keyboard Controller
24h	Set ES segment register to 4 GB
28h	Auto size DRAM
29h	Initialize POST Memory Manager
2Ah	Clear 512 kB base RAM
2Ch	1-3-4-1 RAM failure on address line xxxx*
2Eh	1-3-4-3 RAM failure on data bits xxxx* of low byte of memory bus
2Fh	Enable cache before system BIOS shadow
32h	Test CPU bus-clock frequency
33h	Initialize Phoenix Dispatch Manager
36h	Warm start shut down
38h	Shadow system BIOS ROM
3Ah	Auto size cache
3Ch	Advanced configuration of chipset registers
3Dh	Load alternate registers with CMOS values
41h	Initialize extended memory for RomPilot
42h	Initialize interrupt vectors
45h	POST device initialization
46h	2-1-2-3 Check ROM copyright notice
47h	Initialize I20 support
48h	Check video configuration against CMOS
49h	Initialize PCI bus and devices
4Ah	Initialize all video adapters in system
4Bh	QuietBoot start (optional)
4Ch	Shadow video BIOS ROM
4Eh	Display BIOS copyright notice
4Fh	Initialize MultiBoot
50h	Display CPU type and speed
51h	Initialize EISA board
52h	Test keyboard
54h	Set key click if enabled
55h	Enable USB devices
58h	2-2-3-1 Test for unexpected interrupts
59h	Initialize POST display service
5Ah	Display prompt "Press F2 to enter SETUP"
5Bh	Disable CPU cache

POST Code	Description
5Ch	Test RAM between 512 and 640 kB
60h	Test extended memory
62h	Test extended memory address lines
64h	Jump to UserPatch1
66h	Configure advanced cache registers
67h	Initialize Multi Processor APIC
68h	Enable external and CPU caches
69h	Setup System Management Mode (SMM) area
6Ah	Display external L2 cache size
6Bh	Load custom defaults (optional)
6Ch	Display shadow-area message
6Eh	Display possible high address for UMB recovery
70h	Display error messages
72h	Check for configuration errors
76h	Check for keyboard errors
7Ch	Set up hardware interrupt vectors
7Dh	Initialize Intelligent System Monitoring
7Eh	Initialize coprocessor if present
80h	Disable onboard Super I/O ports and IRQs
81h	Late POST device initialization
82h	Detect and install external RS232 ports
83h	Configure non-MCD IDE controllers
84h	Detect and install external parallel ports
85h	Initialize PC-compatible PnP ISA devices
86h	Re-initialize onboard I/O ports.
87h	Configure Motherboard Configurable Devices (optional)
88h	Initialize BIOS Data Area
89h	Enable Non-Maskable Interrupts (NMIs)
8Ah	Initialize Extended BIOS Data Area
8Bh	Test and initialize PS/2 mouse
8Ch	Initialize floppy controller
8Fh	Determine number of ATA drives (optional)
90h	Initialize hard-disk controllers
91h	Initialize local-bus hard-disk controllers
92h	Jump to UserPatch2
93h	Build MPTABLE for multi-processor boards
95h	Install CD ROM for boot
96h	Clear huge ES segment register
97h	Fix up Multi Processor table
98h	1-2 Search for option ROMs. One long, two short beeps on checksum failure

POST Code	Description
99h	Check for SMART Drive (optional)
9Ah	Shadow option ROMs
9Ch	Set up Power Management
9Dh	Initialize security engine (optional)
9Eh	Enable hardware interrupts
9Fh	Determine number of ATA and SCSI drives
A0h	Set time of day
A2h	Check key lock
A4h	Initialize typematic rate
A8h	Erase F2 prompt
AAh	Scan for F2 key stroke
ACh	Enter SETUP
AEh	Clear Boot flag
B0h	Check for errors
B1h	Inform RomPilot about the end of POST.
B2h	POST done - prepare to boot operating system
B4h	1 One short beep before boot
B5h	Terminate QuietBoot (optional)
B6h	Check password (optional)
B7h	Initialize ACPI BIOS
B9h	Prepare Boot
BAh	Initialize SMBIOS
BBh	Initialize PnP Option ROMs
BCh	Clear parity checkers
BDh	Display MultiBoot menu
BEh	Clear screen (optional)
BFh	Check virus and backup reminders
C0h	Try to boot with INT 19
C1h	Initialize POST Error Manager (PEM)
C2h	Initialize error logging
C3h	Initialize error display function
C4h	Initialize system error handler
C5h	PnPnd dual CMOS (optional)
C6h	Initialize note dock (optional)
C7h	Initialize note dock late
C8h	Force check (optional)
C9h	Extended checksum (optional)
CAh	Redirect Int 15h to enable remote keyboard
CBh	Redirect Int 13h to Memory Technologies Devices such as ROM, RAM, PCMCIA, and serial disk
CCh	Redirect Int 10h to enable remote serial video

POST Code	Description
CDh	Re-map I/O and memory for PCMCIA
CEh	Initialize digitizer and display message
D2h	Unknown interrupt

The following are for boot block in Flash ROM

POST Code	Description
E0h	Initialize the chipset
E1h	Initialize the bridge
E2h	Initialize the CPU
E3h	Initialize system timer
E4h	Initialize system I/O
E5h	Check force recovery boot
E6h	Checksum BIOS ROM
E7h	Go to BIOS
E8h	Set Huge Segment
E9h	Initialize Multi Processor
EAh	Initialize OEM special code
EBh	Initialize PIC and DMA
ECh	Initialize Memory type
EDh	Initialize Memory size
EEh	Shadow Boot Block
EFh	System memory test
F0h	Initialize interrupt vectors
F1h	Initialize Run Time Clock
F2h	Initialize video
F3h	Initialize System Management Manager
F4h	Output one beep
F5h	Clear Huge Segment
F6h	Boot to Mini DOS
F7h	Boot to Full DOS

* If the BIOS detects error 2C, 2E, or 30 (base 512K RAM error), it displays an additional word-bitmap (xxxx) indicating the address line or bits that failed. For example, "2C 0002" means address line 1 (bit one set) has failed. "2E 1020" means data bits 12 and 5 (bits 12 and 5 set) have failed in the lower 16 bits. The BIOS also sends the bitmap to the port-80 LED display. It first displays the checkpoint code, followed by a delay, the high-order byte, another delay, and then the loworder byte of the error. It repeats this sequence continuously.

Notes

Appendix C

Installing Software Drivers and the Windows Operating System

C-1 The Adaptec EmCedded SAS/SATA with HostRAID Controller Driver

Introduction to SATA (Serial ATA) and SAS (Serial Attached SCSI) (*SAS is available on the X6DA3-G2 only)

Serial ATA(SATA) is a physical storage interface. It uses a single cable with a minimum of four wires to create a point-to-point connection between devices. It is a serial link which supports SATA transfer rates from 150MBps. Because the serial cables used in SATA are thinner than the traditional cables used in Parallel ATA (PATA), SATA systems provide more efficient system cooling, faster data transfer and better functionality than Parallel ATA.

With the functionality provided by the onboard SAS controller, the Supermicro X6DA3-G2 offers unprecedented I/O throughput, reliability and scalability to the IT industry. In addition, with a dynamic SAS infrastructure built-in, the X6DA3-G2 supports both SATA and SAS without any bridging, providing the user with unparalleled data storage expansion and inter-connectivity capability. (**Note:** The onboard SAS Controller supports both SATA and SAS RAID configuration; however, "mixing-and-matching" SATA and SAS in the configuration is not recommended.)

Using the Adaptec RAID Configuration Utility (ARC)

(*Note: Please also refer to the following sections for SATA RAID Configuration.)

The onboard SAS Controller is enabled by default. To disable it, please set Jumper JPS1 to Pins 2-3 (See Page 2-19 in Chapter 2 for details.)

* Upon detecting the SAS Controller BIOS, please make sure that the Adapter WWN address is listed. This is a 16-digit number. If this number is not shown, you will not be able to use the controller.

* Once the WWN address is listed, press the <Ctrl> and <A> simultaneously when prompted to access the Adaptec SAS RAID BIOS. (**Note:** To select an option, use the arrow keys to highlight the item and then press <Enter> to select it. To return to the previous menu, press <ESC>.)

The Adaptec RAID Configuration Utility is an embedded BIOS Utility, including:

*Array Configuration Utility: Use this utility to create, configure and manage arrays.

* SerialSelect Utility: Use this option to configure SAS/SATA RAID drives.

* Disk Utilities: Use this option to format or verify disks.

A. Using the Array Configuration Utility

The Array Configuration Utility enables you to create, manage, and delete arrays from the controller's BIOS, add and delete spare drives, and initialize drives. During the system startup, press <Ctrl> and <A> simultaneously to display the main menu.

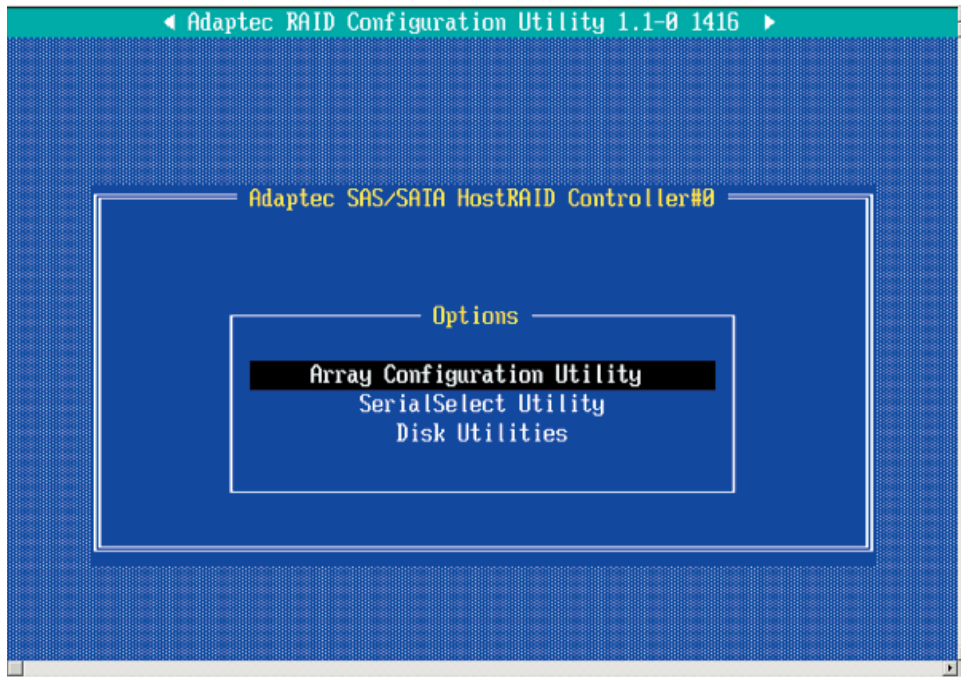

Managing Arrays

Select this option to view array properties, and delete arrays. The following sections describe the operations Of "Managing Arrays".

To select this option, use the arrow keys and the <enter> key to select "Managing Arrays" from the main menu (as shown above).

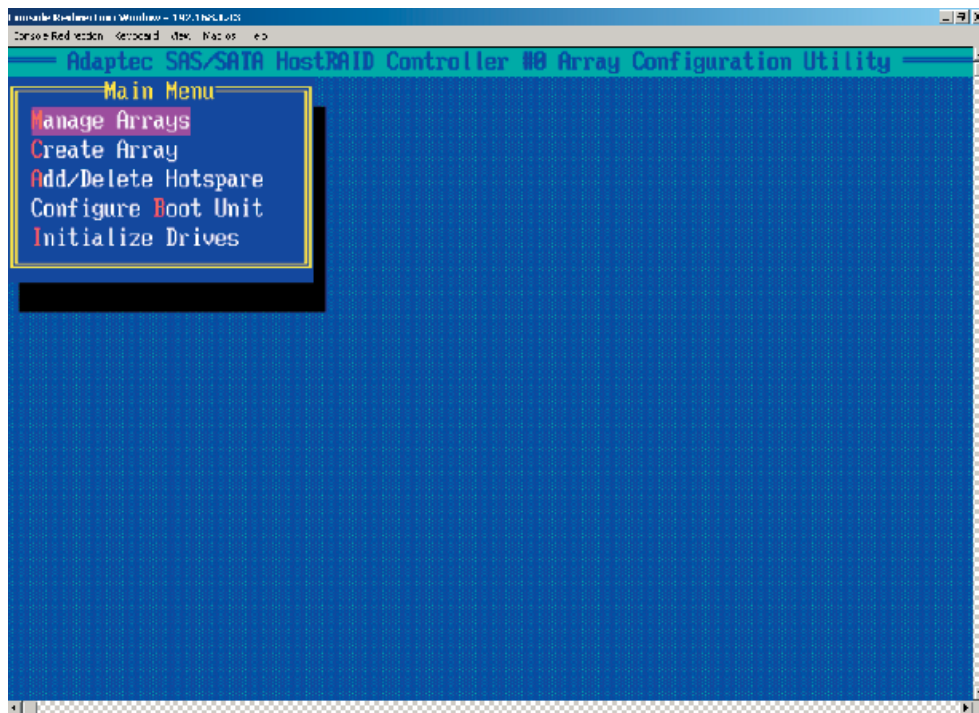

Viewing Array Properties

To view the properties of an existing array:

1. At the BIOS prompt, press **Ctrl+A**.
2. From the Adaptec RAID Configuration Utility menu, select **Array Configuration Utility**.
3. From the Array Configuration Utility menu, select **Manage Arrays** (as shown on the previous screen.)
4. From the List of Arrays dialog box, select the array you want to view and press **Enter**.

The Array Properties dialog box appears, showing detailed information on the array. The physical disks associated with the array are displayed here.

5. Press **Esc** to return to the previous menu.

Deleting Arrays

**Warning: Back up the data on an array before you delete it to prevent the loss of data. Deleted arrays cannot be restored.*

To delete an existing array:

1. Turn on your computer and press **Ctrl+A** when prompted to access the Adaptec RAID Configuration Utility.
2. From the Adaptec RAID Configuration Utility main menu, select **Array Configuration Utility**.
3. From the Array Configuration Utility menu, select **Manage Arrays**.
4. Select the array you wish to delete and press **Delete**.
5. In the Array Properties dialog box, select **Delete** and press **Enter**. The following prompt is displayed:

**Warning!! Deleting the array will render array unusable. Do you want to delete the array?(Yes/No):*

RAID 1 only—the following prompt is also displayed:

Deleting the partition will result in data loss! Do you also want to delete the partition? (Yes/No):

6. Press **Yes** to delete the array or partition or **No** to return to the previous menu.
7. Press **Esc** to return to the previous menu.

Creating Arrays

Before creating arrays, make sure the disks for the array are connected and installed in your system. Note that disks with no usable space, or disks that are uninitialized are shown in gray and cannot be used. Refer to the section: [Initializing Disk Drives](#).

To create an array:

- 1 Turn on your computer and press **Ctrl+A** when prompted to access the Adaptec RAID Configuration Utility.
- 2 From the Adaptec RAID Configuration Utility menu, select **Array Configuration Utility Main Menu**.
- 3 From the Array Configuration Utility menu, select **Create Array**.
- 4 Select the disks for the new array and press Insert (as the screen shown below).
 (*Note: To deselect any disk, highlight the disk and press **Delete**.)

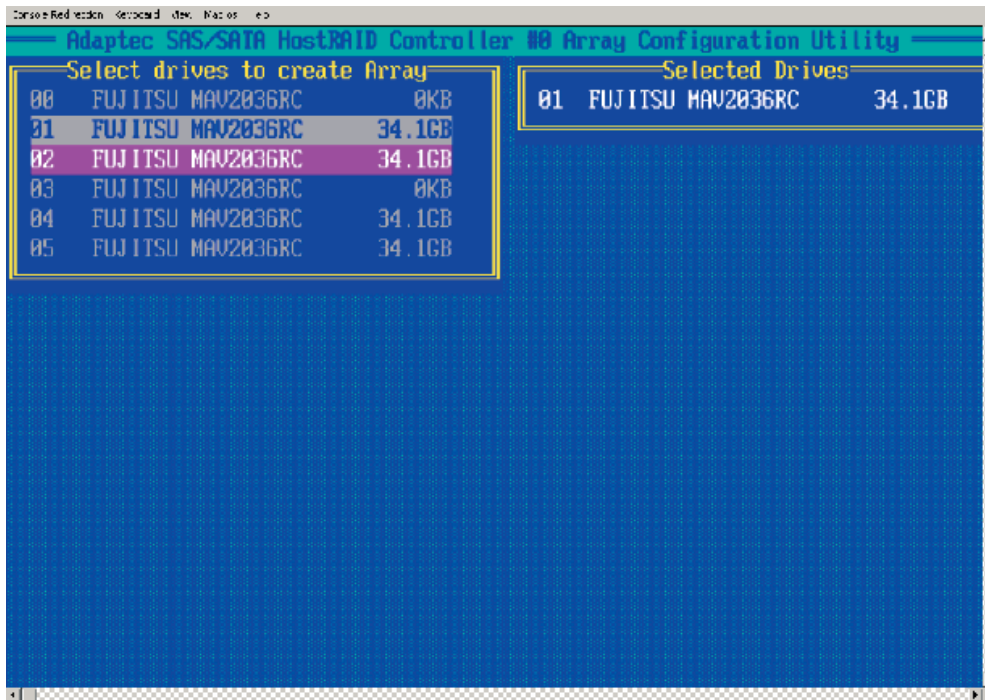

- 5 After both disks for the new array are selected, press Enter. The Array Properties menu displays (as the screen shown below).

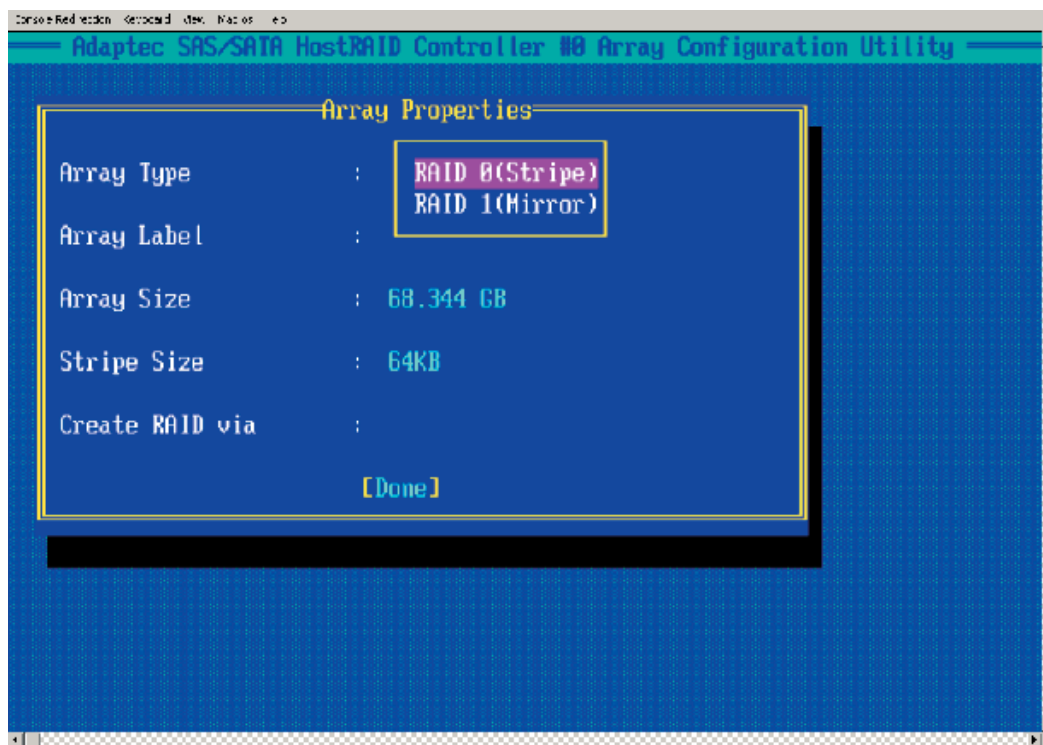

Assigning Array Properties

Once you've create a new array, you are ready to assign the properties to the array.

***Caution:** Once the array is created and its properties are assigned, you cannot change the array properties using the Array Configuration Utility. You will need to use the Adaptec Storage Manager. (Refer to Adaptec's User's Guide in the enclosed CD.)

To assign properties to the new array:

1. In the Array Properties menu (as shown in the screen below), select an array type and press **Enter**.

Note that only the available array types: RAID 0, and RAID1, are displayed on the screen. (*RAID 0 or RAID 1 requires two drives.)

2. Under the item "**Arrays Label**", type in an label and press **Enter**. (***Note:** The label shall not be more than 15 characters.)

3. For RAID 0, select the desired stripe size. (***Note:** Available stripe sizes are 16, 32, and 64 KB-default. It is recommended that you *do not* change the default setting.)

4. The item: "**Create RAID via**" allows you to select between the different creating methods for RAID 0 and RAID 1.

The following table gives examples of when each is appropriate.

Raid Level	Create Via	When Appropriate
RAID 0	No Init	Creating a RAID 0 on new drives
RAID 1	Build	Any time you wish to create a RAID 1, but especially if you have data on one drive that you wish to preserve
RAID 1	Clear	Creating a RAID 1 on new drives, or when you want to ensure that the array contains no data after creation.
RAID 1	Quick	Fastest way to create a RAID 1. Appropriate when using new drives
RAID 1	Init	

5. When you are finished, press **Done (as shown in the previous screen)**.

Notes:

1. Before adding a new drive to an array, back up any data contained on the new drive. Otherwise, all data will be lost.
2. If you stop the Build or Clear process on a RAID 1 from Array Configuration Utility, you can restart it by pressing Ctrl+R.
3. A RAID 1 created using the Quick Init option may return some data mis-compare if you later run a consistency check. This is normal and is not a cause for concern.
4. The Array Configuration Utility allows you to use drives of different sizes in a RAID. However, during a build operation, only the smaller drive can be selected as the source or first drive.
5. When migrating from single volume to RAID 0, migrating from a larger drive to a smaller drive is allowed. However, the destination drive must be at least half the capacity of the source drive.
6. Adaptec does not recommend that you migrate or build an array on Windows dynamic disks (volumes), as it will result in data loss.

Warning: Do not interrupt the creation of a RAID 0 using the Migrate option. If you do, you will not be able to restart, or to recover the data that was on the source drive.

Adding a Bootable Array

To make an array bootable:

1. From the Main menu, select **Configure Boot Unit** and press Enter. The following screen displays.

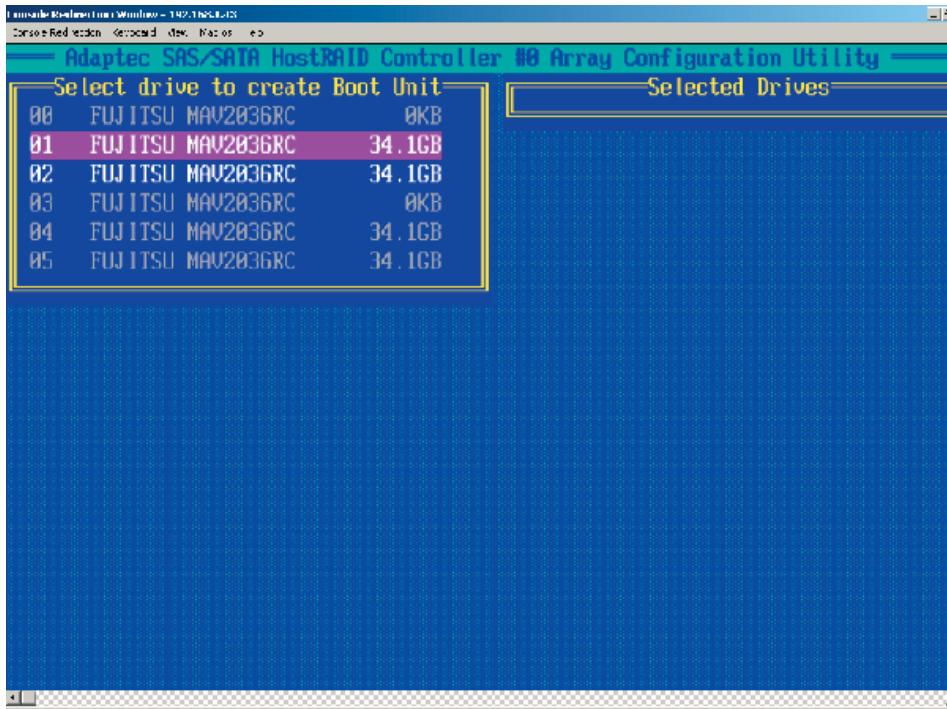

2. From the "Select Drive to Create Boot Unit" list, select the drive you wish to **Configure Boot Unit** and press Insert. The Drive you have selected appears in the right window as shown in the screen below:

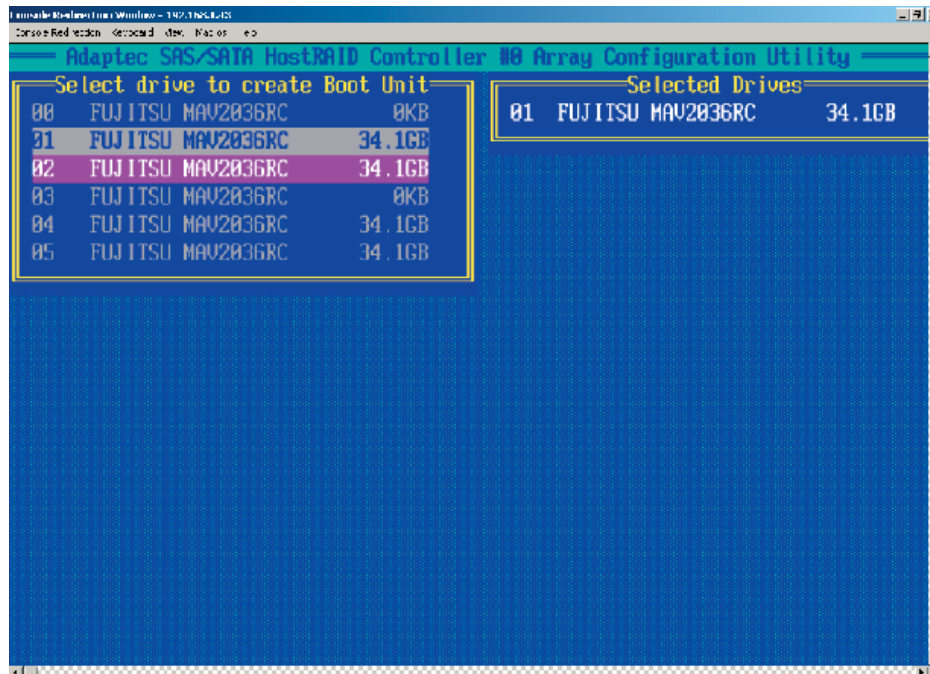

3. Select the disk drive you wish to configure as a bootable drive from the "Selected Drives" List (in the right window) and press Enter. The next screen appears.

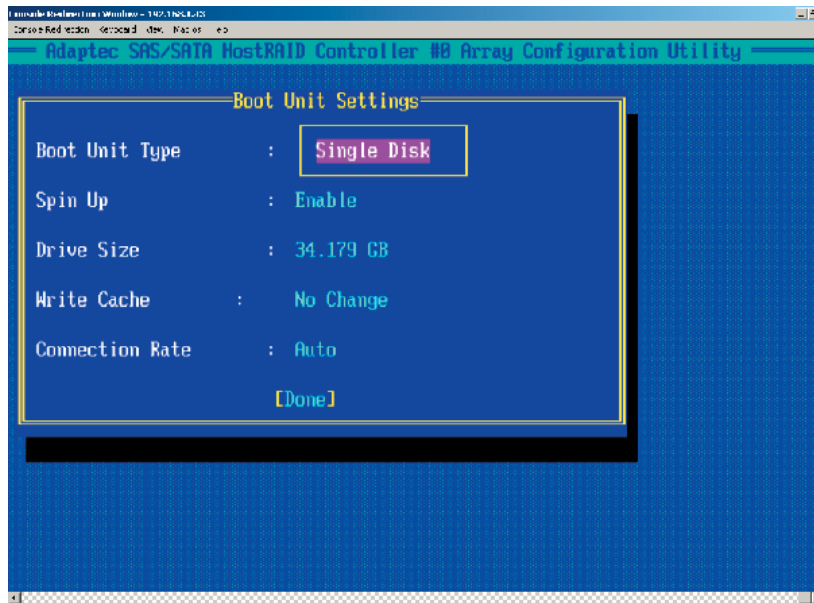

Deleting a Bootable Array

To delete a bootable array:

1. From the Main menu, select **Configure Boot Unit** and press Enter.
2. From the "Select the Boot Unit" list (in the right window), select the bootable drive you wish to delete and press Delete. The following screen appears:

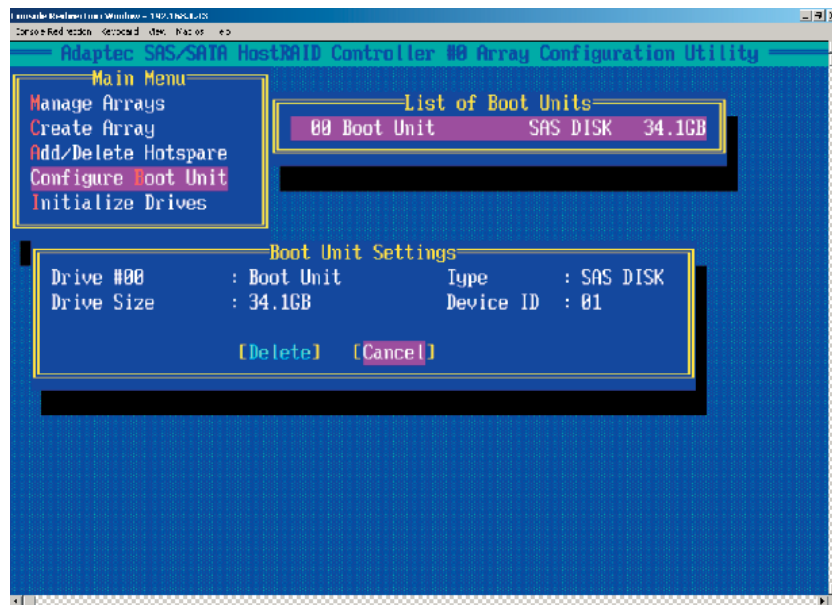

3. When the screen shown above appears, select Delete and press Enter.
4. Enter Y to delete a bootable array when the following message is displayed: "Do you want to delete the Bootable uUnit? (Yes/No):" Then, the bootable array will be deleted.

Adding/Deleting Hotspares

(*Note: In order to rebuild a RAID (RAID 0 or RAID 1), you would need to add a new HDD as a hotspare.)

1. Turn on your computer and press Ctrl+A as prompted to access the ARC Utility.
2. From the ARC menu, select Array Configuration Utility.
3. From the ACU menu, select **Add/Delete Hotspares** and press <Enter>. The following screen appears:

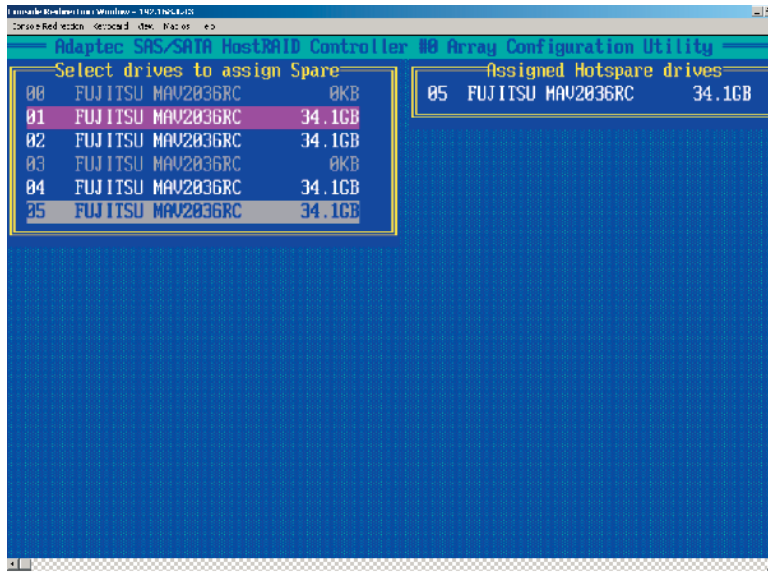

To Add a HotSpare Drive

4. Use the up and down arrow keys to highlight and select the disk you want to designate as a Hotspare, and press <Insert>, and then, press <Enter>.
5. Press yes when the following prompt is displayed: "Do you want to create spare?" (Yes/No?)

The spare you have selected will appear in the Select Drive Menu.

To Delete a HotSpare Drive

4. From the List of "Assigned HotSpare Drives" (in the right window), select the hotspare drive you want to delete, and press <Delete> and <Enter>.
5. Press yes when the following prompt is displayed: "Do you want to Delete the Hotspare?" (Yes/No?)

The hotspare drive you have selected will be deleted.

Initializing Disk Drives

If an installed disk does not appear in the disk selection list for creating a new array, or if it appears grayed out, you may have to initialize it before you can use it as part of an array. Drives attached to the controller must be initialized before they can be used in an array.

Caution: Initializing a disk overwrites the partition table on the disk and makes any data on the disk inaccessible. If the drive is used in an array, you may not be able to use the array again.

Do not initialize a disk that is part of a boot array. To determine which disks are associated with a particular array, Please refer to [Viewing Array Properties](#).

To initialize drives:

1. Turn on your computer and press **Ctrl+A** when prompted to access the Adaptec RAID Configuration utility.
2. From the Adaptec RAID Configuration Utility menu, select **Array Configuration Utility** (as shown in the screen below).

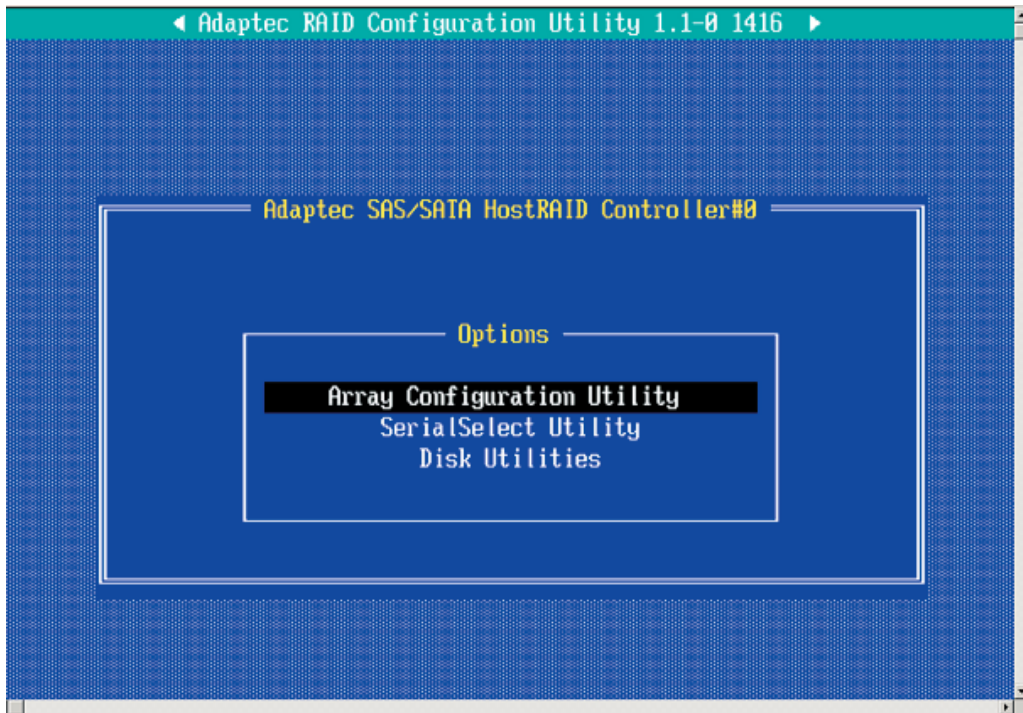

3. From the screen below, select **Initialize Drives** and press <Enter>.

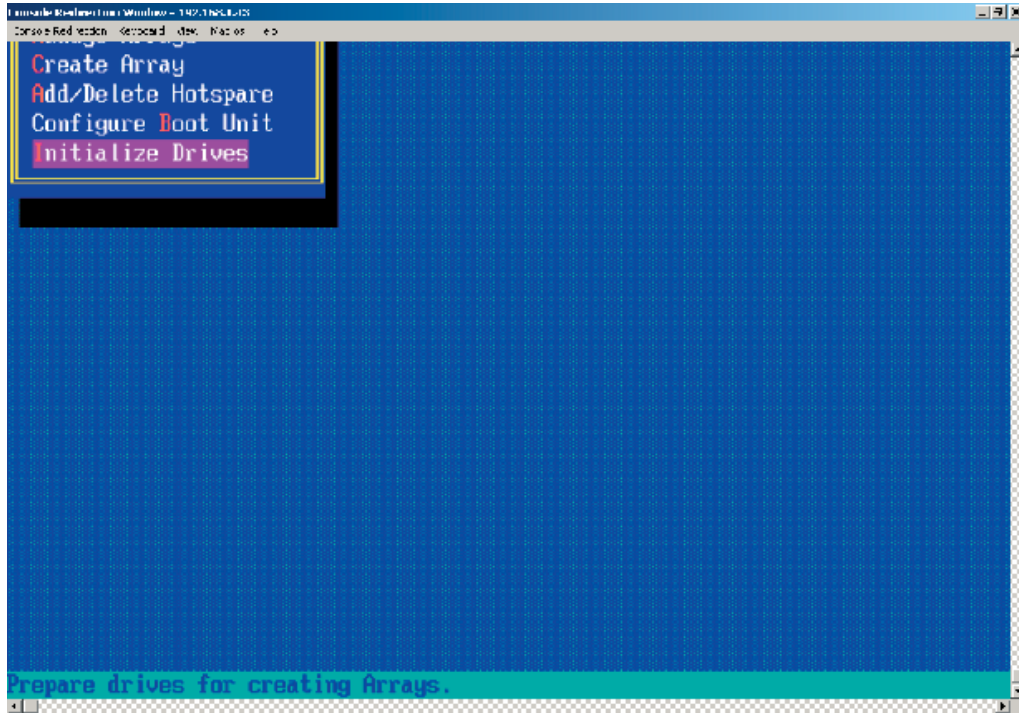

4. From the "Select drives for initialization" list (on the left screen), select the disk you wish to initialize and press Insert. The drive you've selected will appear on the "Selected Drives" list as show below:

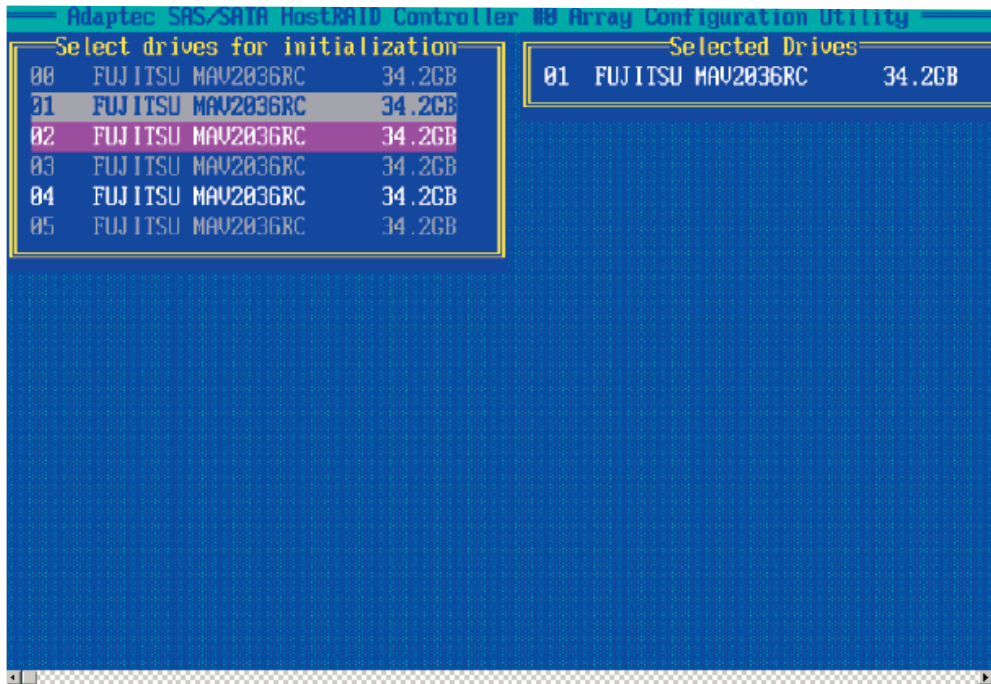

5. Repeat [Step 4](#) so that both drives to be initialized are selected and press <Enter>.

6. When the following message appears, make sure that you have selected the correct drive for initialization and press <Y> to initialize the drive or press <N> to quit.

Warning: Initialization will configure the drive(s) as simple volume disk(s). Do you want to continue? (Yes/No):

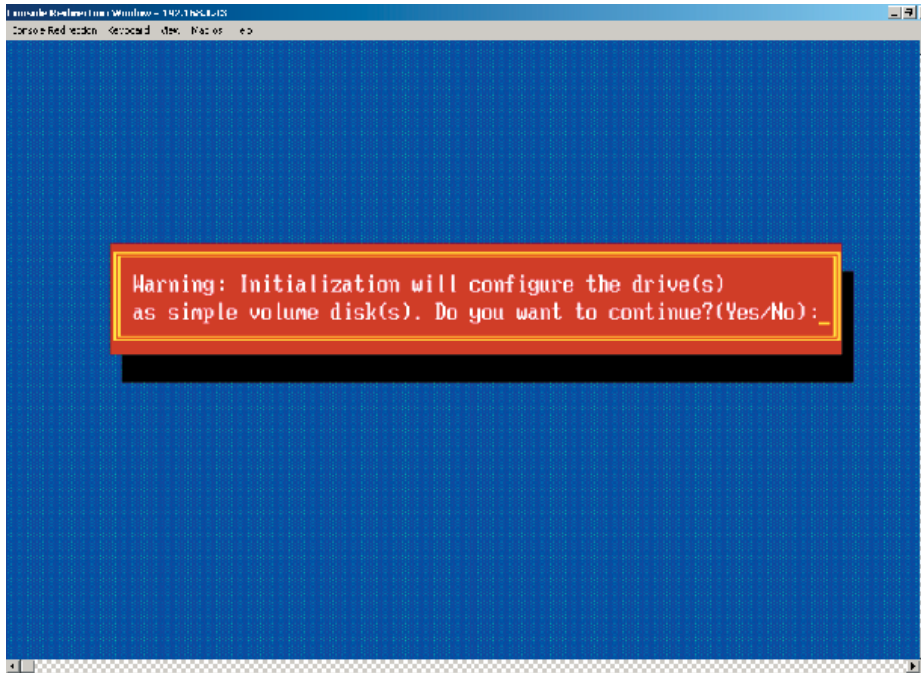

Rebuilding Arrays

***Note 1:** Rebuilding applies to Fault Tolerant array (RAID 1) only.

If an array Build process (or initialization) is interrupted or critical with one member missing, you must perform a Rebuild to get the array to Optimal status. For a critical array Rebuild operation, the optimal drive is the source drive.

***Note 2:** If no spare array exists and a hard disk drive fails, you need to create a spare before you can rebuild an array.

To Rebuild an array:

1 From the Main Menu, select **Manage Arrays** (as shown in the screen below). From the List of Arrays, select the array you want to Rebuild.

2 Press **Ctrl+R** to Rebuild.

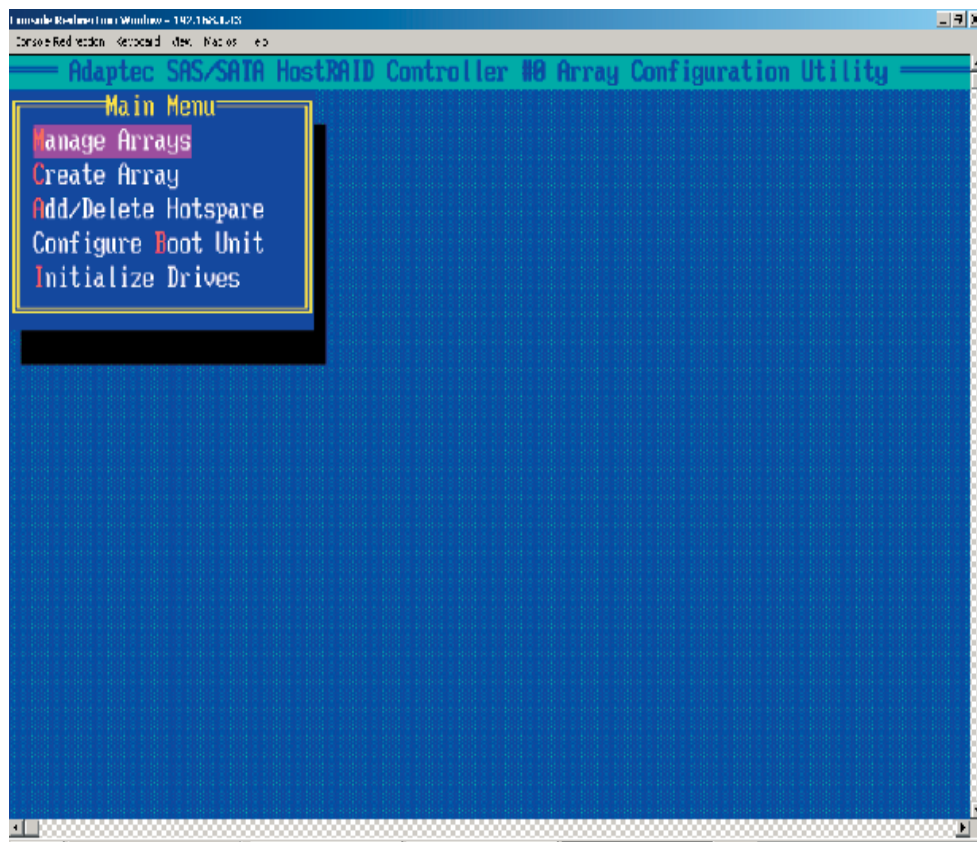

Using the SerialSelect Utility to Configure SAS Settings

The SerialSelect Utility enables you to configure SAS disk drive settings.

To access the SAS utilities:

1. Turn on your computer and press Ctrl+A when prompted to access the Adaptec RAID Configuration Utility. (as shown in the screen below.)

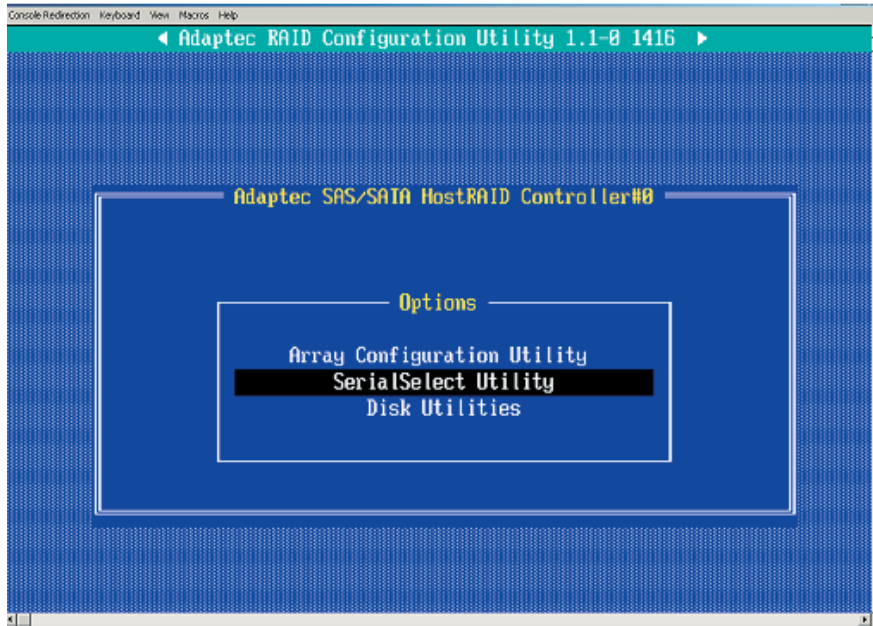

2. Use the arrow keys to select "SerialSelect Utility" and press <Enter> to access the Controller Configuration submenu:

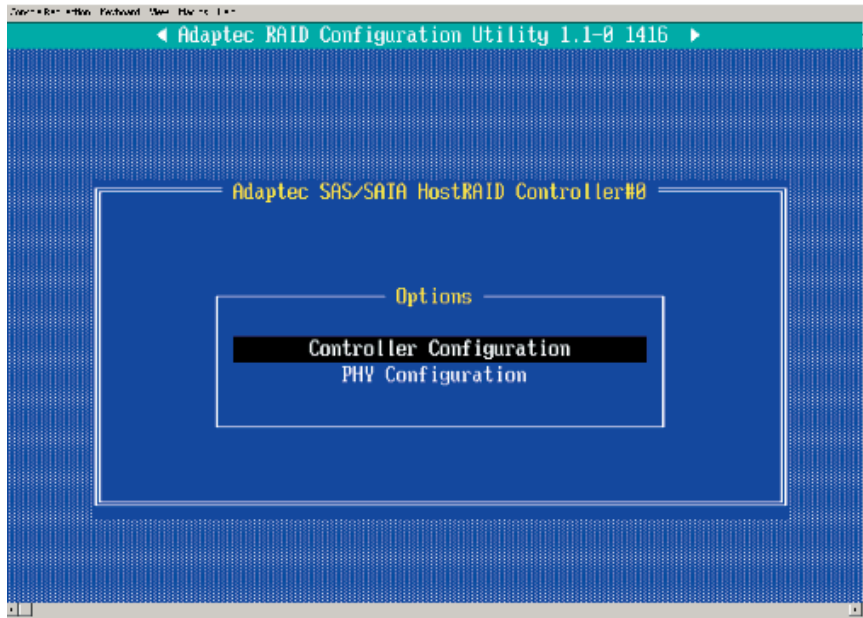

To Set Controller Configuration:

3. Select "Controller Configuration" and press <Enter> to access the submenu as shown below:

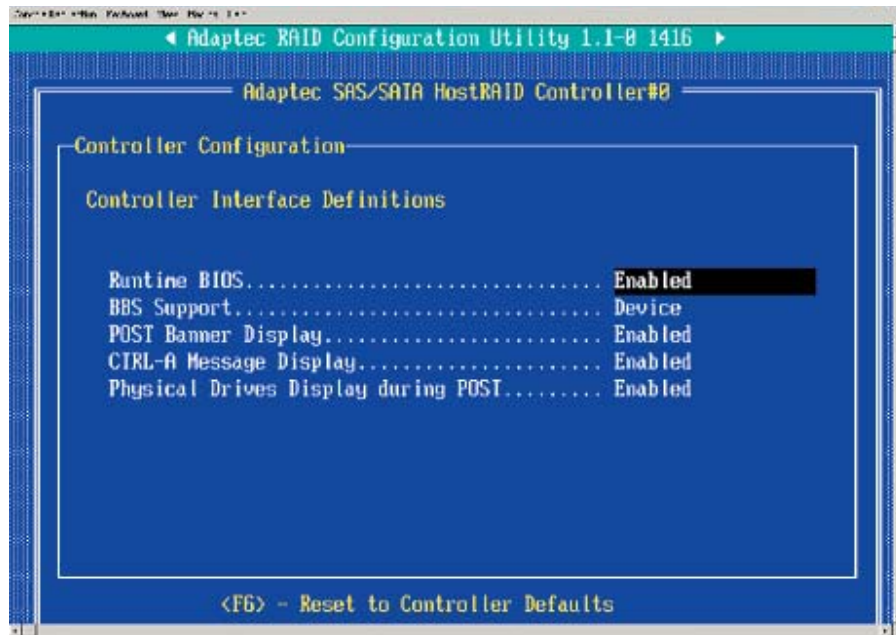

4. Use the arrow keys to select an item. Then, press <Enter> and the arrow keys to configure the setting for the item selected.

5. To load the default settings, press <F6>.

(*Note: The default setting for each item is listed below:

Runtime BIOS: Enabled,

BBS Support: Device,

POST Banner Display: Enabled,

CTRL-A Message Display: Enabled,

Physical Drives Display during POST: Enabled,)

6. Press <Esc> to return to the previous menu and to exit the utility.

To Set Physical Configuration:

1. Turn on your computer and press **Ctrl+A** when prompted to access the Adaptec RAID Configuration Utility.
2. Use the arrow keys to select "SerialSelect Utility" and press <Enter> to access the Physical Configuration submenu as shown below:

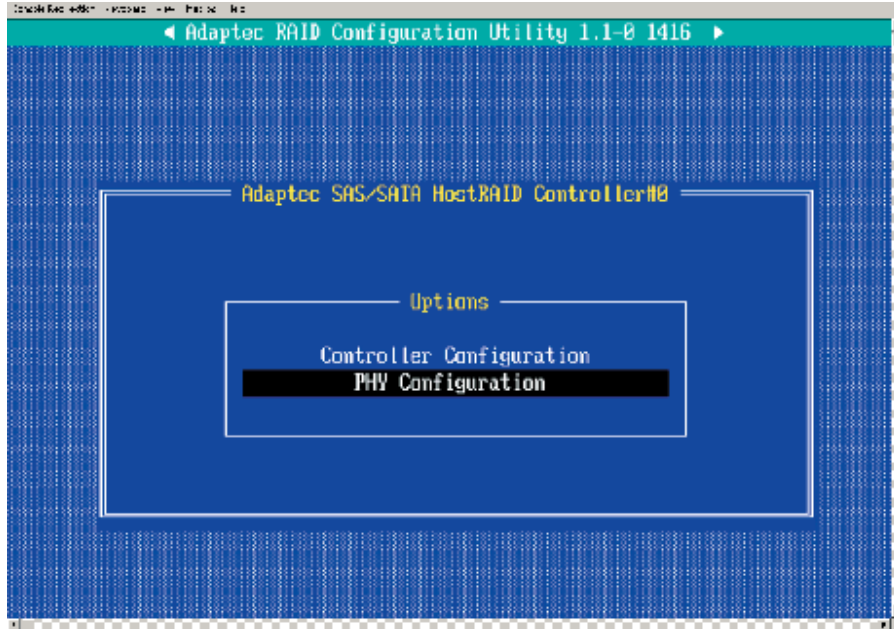

3. Select "Physical Configuration" and press <Enter> to access SAS Device Configuration submenu as shown below:

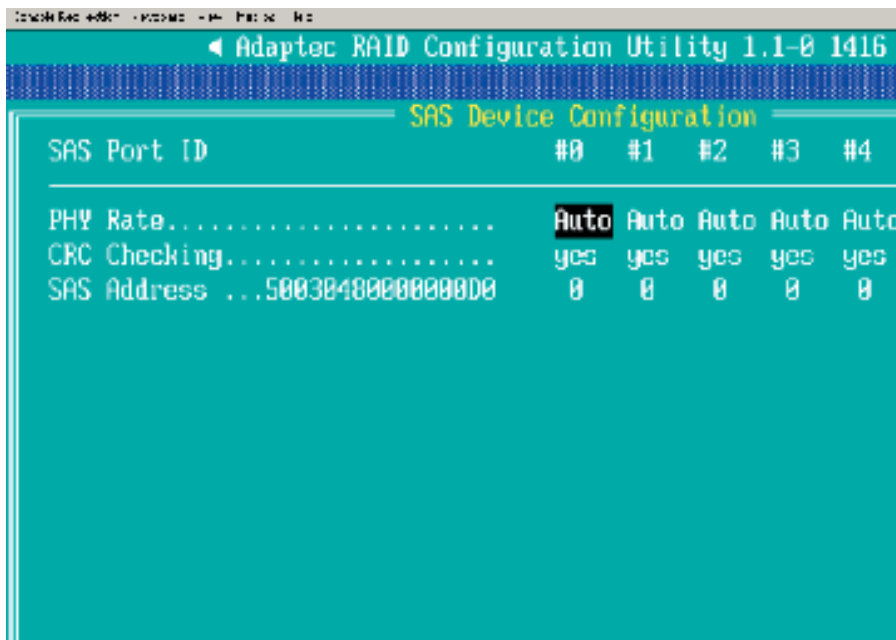

4. Use the arrow keys to select an item. Then, press <Enter> and the arrow keys to configure the item selected.
5. To load default settings, press <F6>.
6. Press <Esc> to return to the previous menu and to exit the utility.

Using the Disk Utilities

The Disk Utilities enable you to format or verify the media of your Serial ATA hard disks.

To access the disk utilities:

1. Turn on your computer and press **Ctrl+A** when prompted to access the Adaptec RAID Configuration Utility (as shown in the screen below.)

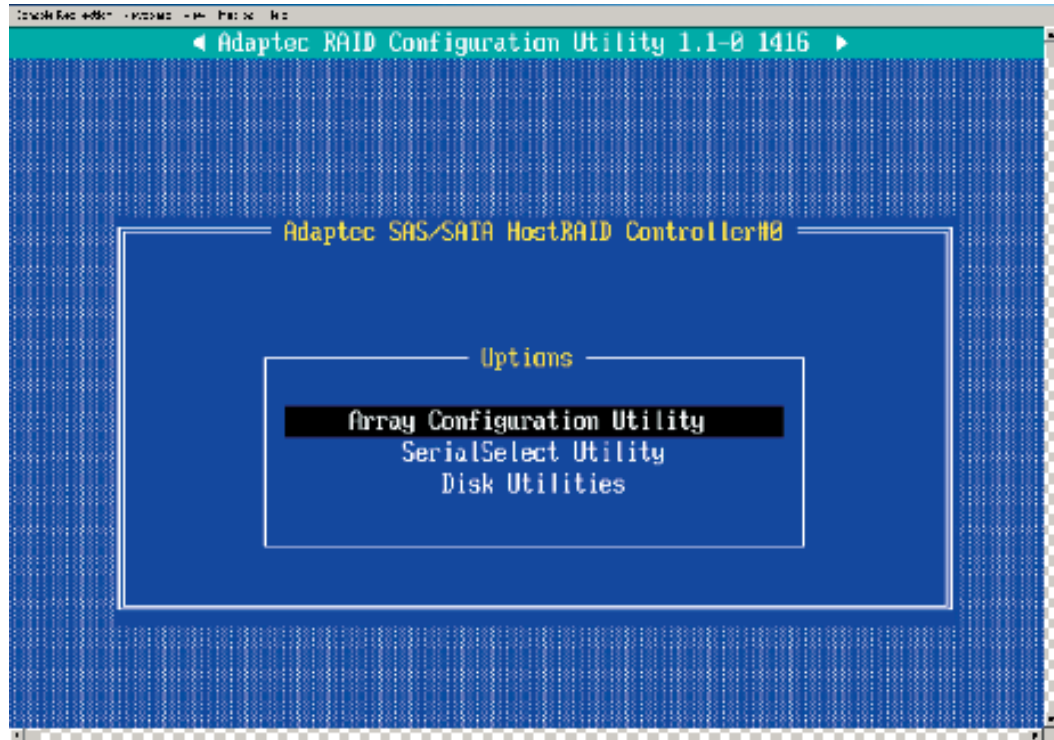

2. From the Adaptec RAID Configuration Utility menu, select **Disk Utilities** from the screen as shown above and press Enter.
3. When the submenu appears, select the desired disk and press **Enter**.

The following options are available:

1. **Format Disk**—Simulates a low-level format of the hard drive by writing zeros to the entire disk. (*Note: Serial ATA drives are low-level formatted at the factory and do not need to be low-level formatted again.)

(***Caution:** Formatting disk erases all data on the drive. Be sure to back up your data before performing this operation.)

2. **Verify Disk Media**—Scans the media of a disk drive for defects.

To Exit Adaptec RAID Configuration Utility

1. Once you have completed RAID array configurations, press **ESC** to exit. The following screen will appear.
2. Press **Yes** to exit the Utility.

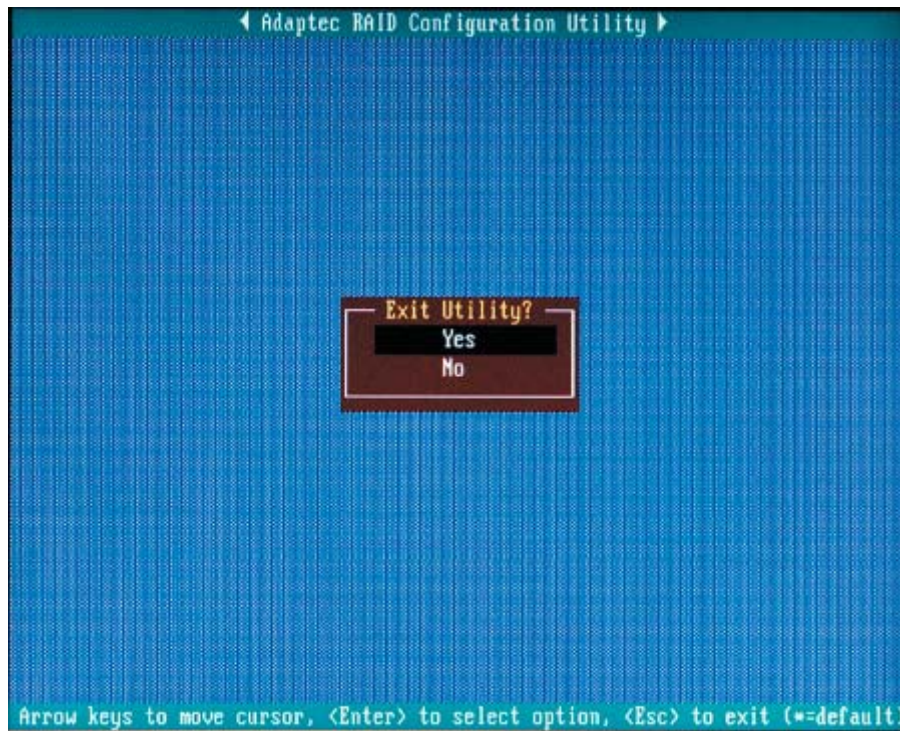

(*For more information regarding Adaptec RAID Utility, please refer to Adaptec's User's Guide in the CD included in your shipping package. You can also download a copy of Adaptec User's Guide from our web site at: www.supermicro.com.)

C-2 Installing the ICH5R/SAS Driver and the OS

- a. Insert Supermicro's bootable CD that came with the package into the CD Drive during the system reboot, and the screen: "Super Micro Driver Diskette Maker" will appear.
- b. From the list displayed on the screen, choose the item: "Intel 6300 ESB/ICH5R Driver by 3rd Party (Adaptec)" or "SAS" and press <ENTER>.
- c. From the next screen displayed, choose the OS driver you want to install and press <Enter>.
- d. Insert a formatted diskette into drive A: and press <Enter> as prompted.
- e. Exit the program after the process is completed. Then, reboot the system.
- f. Insert Microsoft Windows OS Setup CD in the CD Driver, and the system will start to boot up from CD.
- g. Press the <F6> key when the message-"Press F6 if you need to install a third party SCSI or RAID driver" displays.
- h. When the Windows OS Setup screen appears, press "S" to specify additional device(s).
- i. Insert the driver diskette-"Adaptec Embedded Serial ATA Raid Controller Driver" into Drive A: and press the <Enter> key.
- j. Choose Adaptec Embedded Host Serial ATA Raid Controller from the list indicated in the Windows OS Setup Screen, and press the <Enter> key.
- k. Press the <Enter> key to continue the installation process. (If you need to specify any additional devices to be installed, do it at this time.) Once all devices are specified, press the <Enter> key to continue with the installation.
- l. From the Windows OS Setup screen, press the <Enter> key. The OS Setup will automatically load all device files, and, then, continue the Windows OS installation.
- m. After Windows OS Installation is completed, the system will automatically reboot.

C-3 Installing Other Software Programs and Drivers

A. Installing Drivers other than Adaptec Embedded Serial ATA RAID Controller Driver

After you've installed Windows Operating System, a screen as shown below will appear. You are ready to install software programs and drivers that have not yet been installed. To install these software programs and drivers, click the icons to the right of these items.

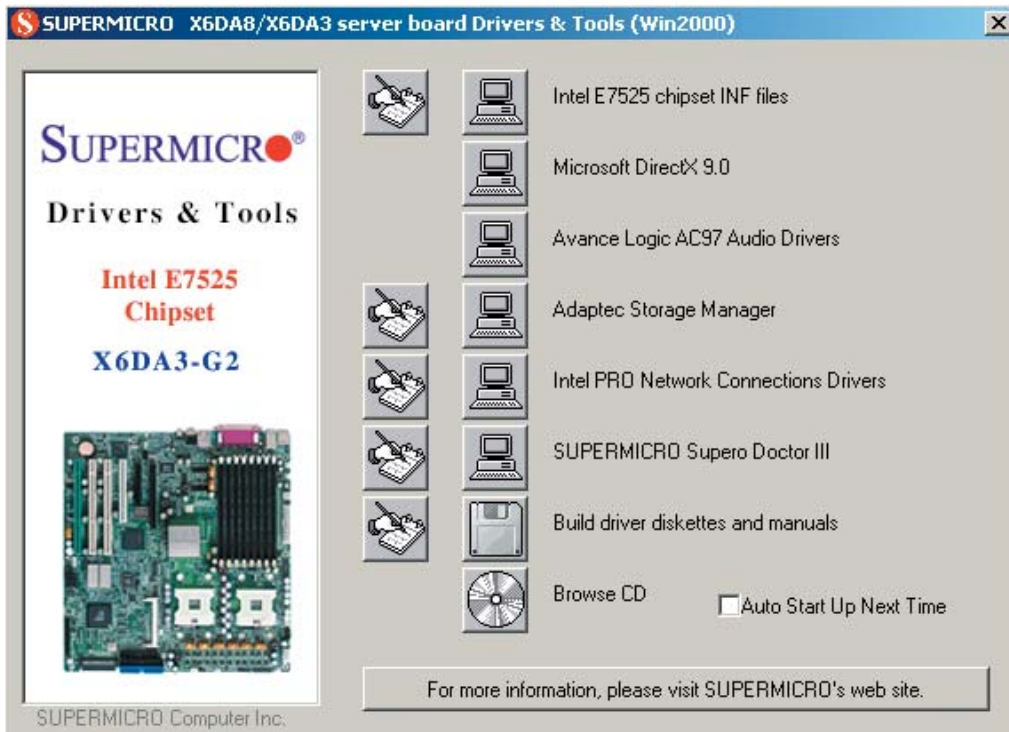

Driver/Tool Installation Display Screen

(*Note: Click the icons showing a hand writing on paper to view the readme files for each item. Click the computer icons to the right of these items to install each item (from top to the bottom) one at a time. **After installing each item, you must re-boot the system before moving on to the next item on the list.** You should install everything here except for the Supero Doctor utility, Intel LDCM and the LAN/SCSI driver diskettes, which are optional. The bottom icon with a CD on it allows you to view the entire contents of the CD.)

(*Please refer to the Adaptec User's Guide for the installation of Adaptec's Serial ATA RAID Controller Driver. Adaptec's User's Guide is included in the CD. You can also download a copy of the user's guide from our web site.)

Supero Doctor III

The Supero Doctor III program is a Web base management tool that supports remote management capability. It includes Remote and Local Management tools. The local management is called SD III Client. The Supero Doctor III program included on the CDROM that came with your motherboard allows you to monitor the environment and operations of your system. Supero Doctor III displays crucial system information such as CPU temperature, system voltages and fan status. See the Figure below for a display of the Supero Doctor III interface.

Supero Doctor III Interface Display Screen-I (Health Information)

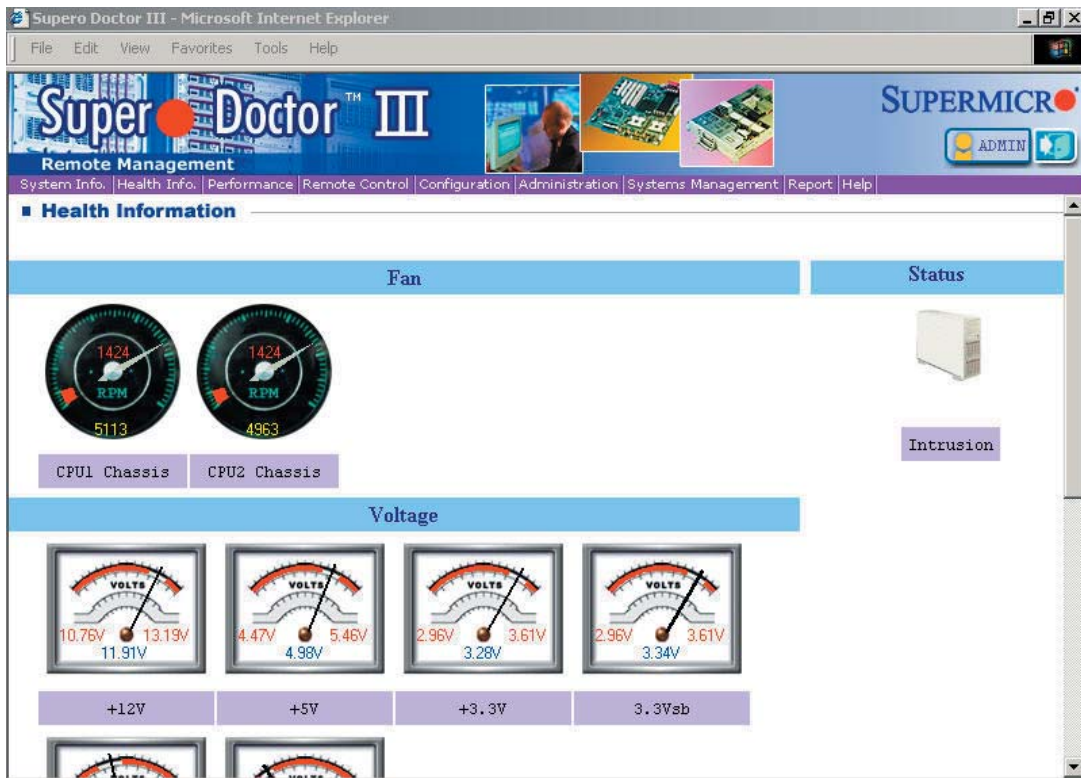

Supero Doctor III Interface Display Screen-II (Remote Control)



Remote Control

System Info | Health Info | Performance | Remote Control | Configuration | Administration | Systems Management | Report | Help

Graceful power control

Supero Doctor III allows a user to inform the OS to reboot or shut down within a specified time (the default is 30 seconds). Before the system reboots or shuts down, it's allowed to cancel the action.

Requirements

Keep Supero SD3Service Daemon running at all times on this system.
Provide TCP/IP connectivity.

Power control

(*Notes: 1. SD III Software Revision 1.0 can be downloaded from our Web site at: ftp://ftp.supermicro.com/utility/Supero_Doctor_III/. You can also download SDIII User's Guide at: <http://www.supermicro.com/PRODUCT/Manuals/SDIII/UserGuide.pdf>. For Linux, we will still recommend Supero Doctor II. 2. For detailed information on Adaptec's SCSI SATA RAID Utility, please refer to the CDs that came with your motherboard.)