



H12DGO-6

USER'S MANUAL

Revision 1.0b

The information in this User's Manual has been carefully reviewed and is believed to be accurate. The vendor assumes no responsibility for any inaccuracies that may be contained in this document, and makes no commitment to update or to keep current the information in this manual, or to notify any person or organization of the updates. **Please Note: For the most up-to-date version of this manual, please see our website at [www.supermicro.com](http://www.supermicro.com).**

Super Micro Computer, Inc. "Supermicro" reserves the right to make changes to the product described in this manual at any time and without notice. This product, including software and documentation, is the property of Supermicro and/or its licensors, and is supplied only under a license. Any use or reproduction of this product is not allowed, except as expressly permitted by the terms of said license.

IN NO EVENT WILL Super Micro Computer, Inc. BE LIABLE FOR DIRECT, INDIRECT, SPECIAL, INCIDENTAL, SPECULATIVE OR CONSEQUENTIAL DAMAGES ARISING FROM THE USE OR INABILITY TO USE THIS PRODUCT OR DOCUMENTATION, EVEN IF ADVISED OF THE POSSIBILITY OF SUCH DAMAGES. IN PARTICULAR, SUPER MICRO COMPUTER, INC. SHALL NOT HAVE LIABILITY FOR ANY HARDWARE, SOFTWARE, OR DATA STORED OR USED WITH THE PRODUCT, INCLUDING THE COSTS OF REPAIRING, REPLACING, INTEGRATING, INSTALLING OR RECOVERING SUCH HARDWARE, SOFTWARE, OR DATA.

Any disputes arising between manufacturer and customer shall be governed by the laws of Santa Clara County in the State of California, USA. The State of California, County of Santa Clara shall be the exclusive venue for the resolution of any such disputes. Supermicro's total liability for all claims will not exceed the price paid for the hardware product.

FCC Statement: This equipment has been tested and found to comply with the limits for a Class A or Class B digital device pursuant to Part 15 of the FCC Rules. These limits are designed to provide reasonable protection against harmful interference when the equipment is operated in industrial environment for Class A device or in residential environment for Class B device. This equipment generates, uses, and can radiate radio frequency energy and, if not installed and used in accordance with the manufacturer's instruction manual, may cause harmful interference with radio communications. Operation of this equipment in a residential area is likely to cause harmful interference, in which case you will be required to correct the interference at your own expense.

California Best Management Practices Regulations for Perchlorate Materials: This Perchlorate warning applies only to products containing CR Manganese Dioxide Lithium coin cells. "Perchlorate Material-special handling may apply. See [www.dtsc.ca.gov/hazardouswaste/perchlorate](http://www.dtsc.ca.gov/hazardouswaste/perchlorate)".



**WARNING:** This product can expose you to chemicals including lead, known to the State of California to cause cancer and birth defects or other reproductive harm. For more information, go to [www.P65Warnings.ca.gov](http://www.P65Warnings.ca.gov).

The products sold by Supermicro are not intended for and will not be used in life support systems, medical equipment, nuclear facilities or systems, aircraft, aircraft devices, aircraft/emergency communication devices or other critical systems whose failure to perform be reasonably expected to result in significant injury or loss of life or catastrophic property damage. Accordingly, Supermicro disclaims any and all liability, and should buyer use or sell such products for use in such ultra-hazardous applications, it does so entirely at its own risk. Furthermore, buyer agrees to fully indemnify, defend and hold Supermicro harmless for and against any and all claims, demands, actions, litigation, and proceedings of any kind arising out of or related to such ultra-hazardous use or sale.

Manual Revision 1.0b

Release Date: March 30, 2021

Unless you request and receive written permission from Super Micro Computer, Inc., you may not copy any part of this document. Information in this document is subject to change without notice. Other products and companies referred to herein are trademarks or registered trademarks of their respective companies or mark holders.

Copyright © 2021 by Super Micro Computer, Inc.  
All rights reserved.

**Printed in the United States of America**

# Preface

## About This Manual

This manual is written for system integrators, IT technicians and knowledgeable end users. It provides information for the installation and use of the H12DGO-6 motherboard.

## About This Motherboard

Built upon the functionality and capability of the Dual AMD EPYC® 7002/7003\* series processor, the H12DGO-6 motherboard provides superior graphics capability and system performance while consuming little power. Please note that this motherboard is intended to be installed and serviced by professional technicians only. For processor/memory updates, please refer to our website at <http://www.supermicro.com/products/>.

\*AMD EPYC 7003 series processor support requires BIOS version 2.0 or newer.

## Conventions Used in the Manual

Special attention should be given to the following symbols for proper installation and to prevent damage done to the components or injury to yourself:



**Warning!** Indicates important information given to prevent equipment/property damage or personal injury.



**Warning!** Indicates high voltage may be encountered when performing a procedure.

## Contacting Supermicro

### Headquarters

Address: Super Micro Computer, Inc.  
980 Rock Ave.  
San Jose, CA 95131 U.S.A.

Tel: +1 (408) 503-8000

Fax: +1 (408) 503-8008

Email: [marketing@supermicro.com](mailto:marketing@supermicro.com) (General Information)  
[support@supermicro.com](mailto:support@supermicro.com) (Technical Support)

Website: [www.supermicro.com](http://www.supermicro.com)

### Europe

Address: Super Micro Computer B.V.  
Het Sterrenbeeld 28, 5215 ML  
's-Hertogenbosch, The Netherlands

Tel: +31 (0) 73-6400390

Fax: +31 (0) 73-6416525

Email: [sales@supermicro.nl](mailto:sales@supermicro.nl) (General Information)  
[support@supermicro.nl](mailto:support@supermicro.nl) (Technical Support)  
[rma@supermicro.nl](mailto:rma@supermicro.nl) (Customer Support)

Website: [www.supermicro.nl](http://www.supermicro.nl)

### Asia-Pacific

Address: Super Micro Computer, Inc.  
3F, No. 150, Jian 1st Rd.  
Zhonghe Dist., New Taipei City 235  
Taiwan (R.O.C)

Tel: +886-(2) 8226-3990

Fax: +886-(2) 8226-3992

Email: [support@supermicro.com.tw](mailto:support@supermicro.com.tw)

Website: [www.supermicro.com.tw](http://www.supermicro.com.tw)

---

---

# Table of Contents

## **Chapter 1 Introduction**

1.1 Quick Reference.....	11
Quick Reference Table.....	12
Motherboard Features.....	13
1.2 Processor and Chipset Overview.....	16
1.3 Special Features .....	16
Recovery from AC Power Loss.....	16
1.4 System Health Monitoring.....	17
Onboard Voltage Monitors .....	17
Fan Status Monitor with Firmware Control .....	17
Environmental Temperature Control .....	17
System Resource Alert.....	17
1.5 ACPI Features.....	18
1.6 Power Supply .....	18
1.7 Super I/O .....	18

## **Chapter 2 Installation**

2.1 Static-Sensitive Devices.....	19
Precautions .....	19
Unpacking .....	19
2.2 Motherboard Installation.....	20
Location of Mounting Holes .....	20
Installing the Motherboard.....	22
2.3 Processor and Heatsink Installation.....	23
2.4 Memory Support and Installation .....	31
Memory Support.....	31
DIMM Module Population Sequence .....	32
DIMM Installation .....	33
DIMM Removal .....	33
2.5 Connectors .....	34
2.6 Jumper Settings .....	36

How Jumpers Work.....	36
2.7 LED Indicators.....	38
<b>Chapter 3 Troubleshooting</b>	
3.1 Troubleshooting Procedures .....	39
Before Power On .....	39
No Power .....	39
No Video .....	40
System Boot Failure.....	40
Memory Errors .....	40
What to do if the System is Losing the Setup Configuration.....	41
When the System Becomes Unstable .....	41
3.2 Technical Support Procedures .....	42
3.3 Frequently Asked Questions .....	43
3.4 Returning Merchandise for Service.....	47
3.5 Battery Removal and Installation .....	47
Battery Removal.....	47
Proper Battery Disposal .....	47
Battery Installation.....	48
<b>Chapter 4 UEFI BIOS</b>	
4.1 Introduction.....	49
Starting the Setup Utility .....	49
4.2 Main Setup .....	50
4.3 Advanced.....	52
4.4 IPMI .....	74
4.5 Event Logs .....	76
4.6 Security Settings .....	78
4.7 Boot Settings.....	82
4.8 Save & Exit.....	84
<b>Appendix A Software</b>	
A.1 Microsoft Windows OS Installation.....	86
A.2 Driver Installation.....	88
A.3 SuperDoctor® 5.....	89
A.4 IPMI .....	89

**Appendix B Standardized Warning Statements**

B.1 Battery Handling .....	90
B.2 Product Disposal .....	92

**Appendix C UEFI BIOS Recovery**

C.1 Overview .....	93
C.2 Recovering the UEFI BIOS Image .....	93
C.3 Recovering the BIOS Block with a USB Device .....	93

# Chapter 1

## Introduction

Congratulations on purchasing your computer motherboard from an industry leader. Supermicro boards are designed to provide you with the highest standards in quality and performance. In addition to the motherboard, several important parts that are included with the system are listed below. If anything listed is damaged or missing, please contact your retailer.

### Important Links

For your system to work properly, please follow the links below to download all necessary drivers/utilities and the user's manual for your server.

- Supermicro product manuals: <http://www.supermicro.com/support/manuals/>
- Product drivers and utilities: <https://www.supermicro.com/wdl/driver/>
- Product safety info: [http://www.supermicro.com/about/policies/safety\\_information.cfm](http://www.supermicro.com/about/policies/safety_information.cfm)
- A secure data deletion tool designed to fully erase all data from storage devices can be found at our website: [https://www.supermicro.com/about/policies/disclaimer.cfm?url=/wftp/utility/Lot9\\_Secure\\_Data\\_Deletion\\_Utility](https://www.supermicro.com/about/policies/disclaimer.cfm?url=/wftp/utility/Lot9_Secure_Data_Deletion_Utility)
- If you have any questions, please contact our support team at: [support@supermicro.com](mailto:support@supermicro.com)

This manual may be periodically updated without notice. Please check the Supermicro website for possible updates to the manual revision level.

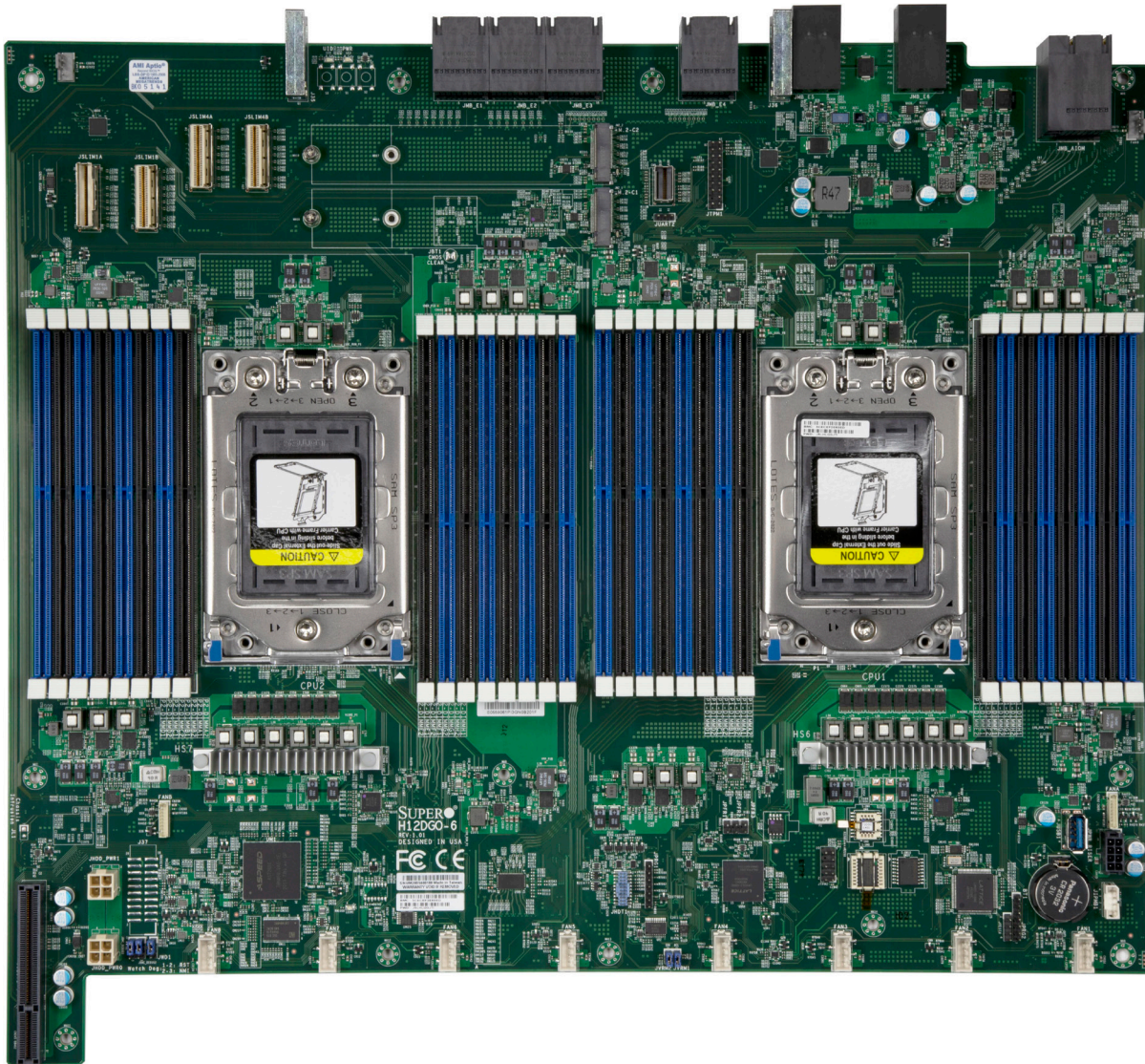

Figure 1-1. H12DGO-6 Motherboard Image

**Note:** All graphics shown in this manual were based upon the latest PCB revision available at the time of publication of the manual. The motherboard you received may or may not look exactly the same as the graphics shown in this manual.

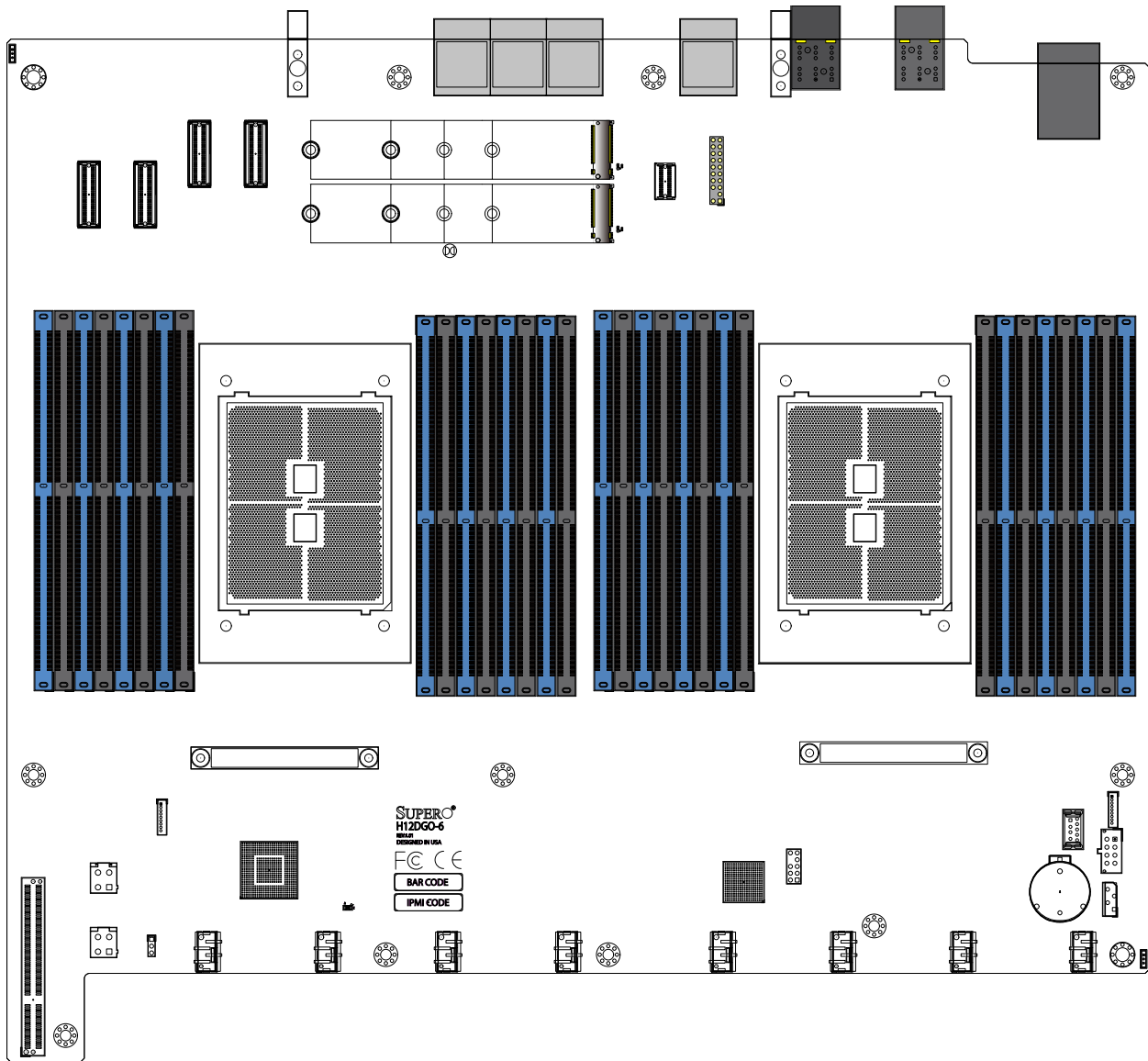
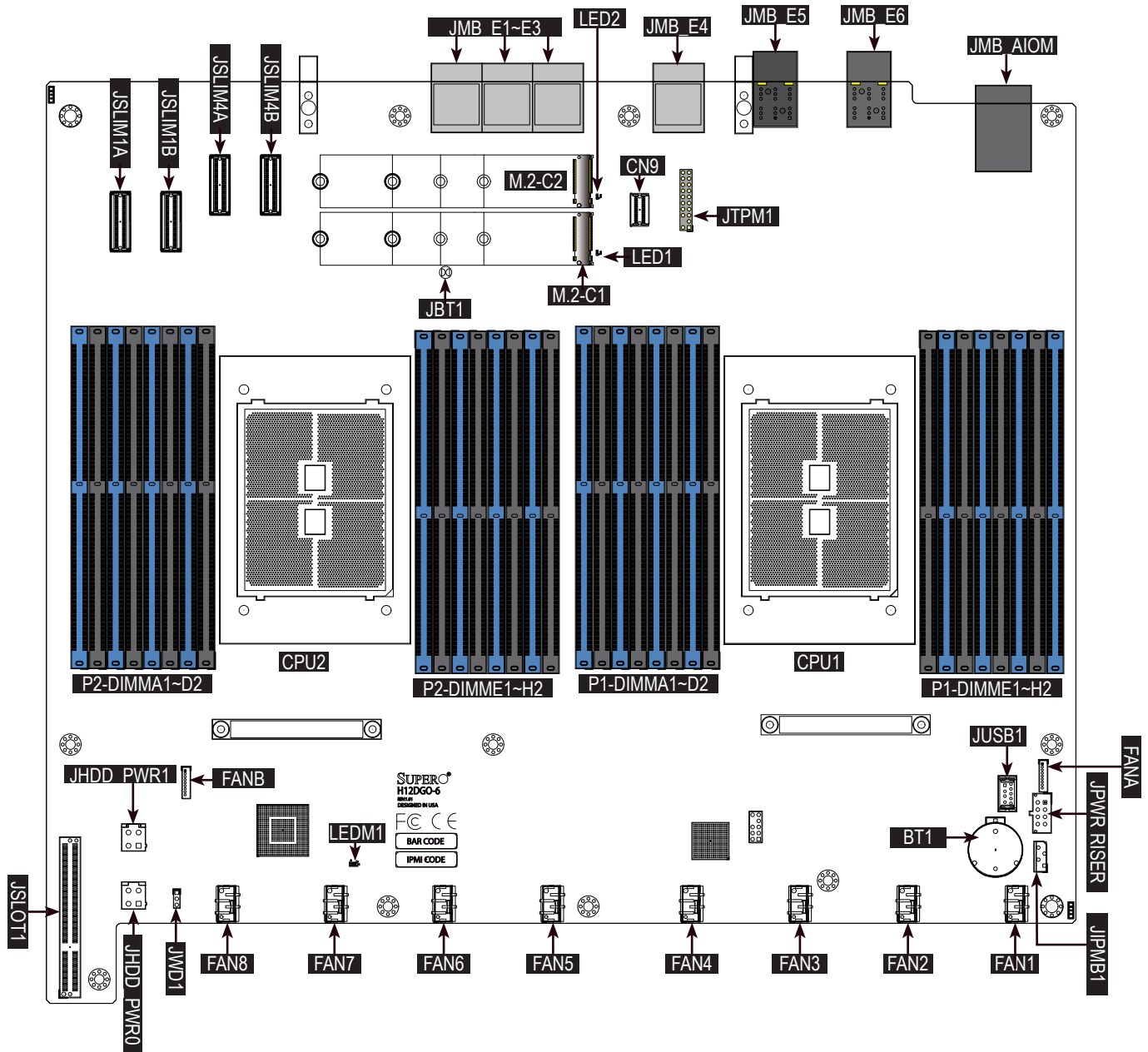

Figure 1-2. H12DGO-6 Motherboard Layout

**Note:** Components not documented are for internal testing only.

## 1.1 Quick Reference



### Notes:

- See Chapter 2 for detailed information on jumpers, I/O ports, and connections.
- Jumpers/LED indicators not indicated are used for testing only.
- Use only the correct type of onboard CMOS battery as specified by the manufacturer. Do not install the onboard battery upside down to avoid possible explosion.

## Quick Reference Table

Jumper	Description	Default Setting
JBT1	CMOS Clear	Open (Normal)
JWD1	Watch Dog Timer Enable	Pins 1-2 (Reset to System)

LED	Description	Status
LEDM1	BMC Heartbeat LED	Green: Blinking (BMC Normal) Green: Fast blinking (BMC Initializing)
LED1	M.2-C1 Active LED	On: M.2-C1 Active
LED2	M.2-C2 Active LED	On: M.2-C2 Active

Connector	Description
JIPMB1	4-pin External I <sup>2</sup> C Header (for an IPMI Card)
BT1	Onboard CMOS Battery Socket
JSLOT1	Supermicro I/O Riser Slot (AOM-DGO-IO)
JMB_AIOM	Supermicro Advanced I/O Module (AIOM) Slot via AOM-438G-AIOM
JMB_E1~JMB_E4	PCIe Connectors (Connect to Middle Plate BPN-GPU-438G)
JMB_E5~JMB_E6	Power Connectors (Connect to Middle Plate BPN-GPU-438G)
M.2-C1, M.2-C2	PCIe M.2 Slots
FANA, FANB	CPU Waterpump Header
FAN1~FAN8	System Fan Headers
JSLIM1A	Processor 2 NVME 4.0 x8
JSLIM1B	
JSLIM4A	Processor 2 PCIe 4.0 x8
JSLIM4B	
JUSB1	Type A USB 3.0 Socket
JPWR_RISER	Power for Riser Cards RSC-G-66G4
CN9	SlimSAS (PCIe 4.0 x4) interface for 4 SATA 3.0 ports
JHDD_PWR0, JHDD_PWR1	Power for SATA/NVMe Backplane BPN-NVMe4-228N-S4
JTPM1	LPC Trusted Platform Module/Port 80 Connector

**Note:** Jumpers in the table not described are for manufacturing testing purposes only and are not covered in this manual.

## Motherboard Features

### Motherboard Features

#### CPU

- Dual AMD EPYC® 7002/7003 series processor in SP3 sockets

#### Memory

- Up to 8TB of ECC DDR4 3200 MHz speed, RDIMM/LRDIMM/3DS/NVDIMM memory in thirty-two slots

#### DIMM Size

- Up to 256GB size at 1.2V

#### Chipset

- System on Chip

#### Expansion Slots

- 16-lane PCIe 4.0 SlimSAS interface to AIOM module (AOM-438G-AIOM) to support Supermicro Advanced I/O Module (AIOM) Networking Adapters
- 24-lane PCIe 4.0 SlimSAS interface to Riser Card (RSC-G-66G4) to support 1 PCIe x16 slot with PCIe x16 signal and 1 PCIe x16 slot with PCIe x8 signal
- 64-lane PCIe 4.0 connected to Middle Plate and Switch Boards to support GPU board and provide extra PCIe x16 slots

#### Graphics

- ASPEED AST2600 BMC chip with one VGA port via AOM-DGO-IO

#### I/O Devices

- One COM Port Connector on front I/O panel
- Two internal NVMe (PCIe 4.0 x4) ports via 1 SlimSAS (PCIe 4.0 x8) interface
- Four SATA 3.0 ports (SATA0~SATA3) via SlimSAS (PCIe 4.0 x4) interface

#### Peripheral Devices

- Two USB 3.0 ports on the front I/O panel (USB2/3)

#### BIOS

- 256Mb SPI AMI BIOS® SM Flash UEFI BIOS
- ACPI 6.2, SMBIOS 3.1.1, Plug-and-Play (PnP), RTC (Real Time Clock) wakeup, Riser Card Auto-Detection support

## Motherboard Features

### Power Management

- ACPI power management (S5)
- Power button override mechanism
- Power-on mode for AC power recovery

### System Health Monitoring

- Onboard voltage monitoring for +3.3V, +3.3V Standby, +5V, +5V Standby, +12V, VBAT, Vcore, Vsoc, and Memory
- Onboard temperature monitoring for CPU, System, and Memory
- CPU switching phase voltage regulator
- CPU Thermal Trip support
- CPU Thermal Design Power (TDP) support of up to 280W (See Note at the bottom)

### Fan Control

- Dual cooling zone
- Low-noise fan speed control
- Pulse Width Modulation (PWM) fan control

### System Management

- Trusted Platform Module (TPM) support
- System resource alert via SuperDoctor® 5
- Power Supply Monitoring
- SuperDoctor® 5, Watch Dog, NMI
- SPM, SUM-InBand, SUM-OOB, IPMICFG, IPMIView, SMCIPMITOOL

### LED Indicators

- BMC Heartbeat Indicator
- M.2 Active LED
- Power State Indicator (via Front I/O Panel AOM-DGO-IO)
- Fan Failure (via Front I/O Panel AOM-DGO-IO)
- LAN Activity (via Front I/O Panel AOM-DGO-IO)
- UID/Remote UID (via Front I/O Panel AOM-DGO-IO)

### Dimensions

- 16.86" (L) x 15.11" (W) (428.24 mm x 383.79 mm)

**Note:** The CPU maximum thermal design power (TDP) is subject to chassis and heatsink cooling restrictions. For proper thermal management, please check the chassis and heatsink specifications for proper CPU TDP sizing.

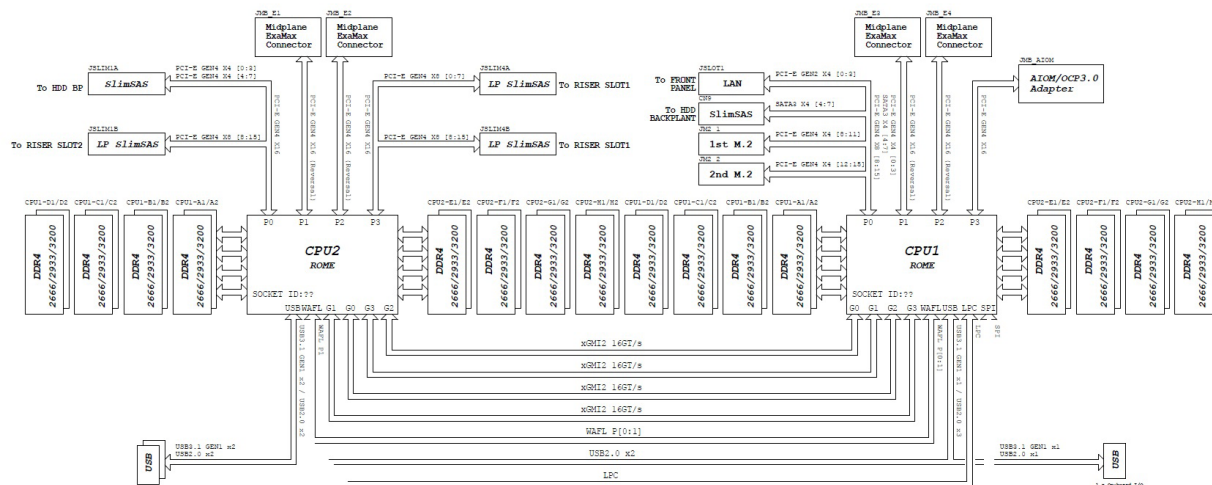

Figure 1-3. System Block Diagram

**Note:** This is a general block diagram and may not exactly represent the features on your motherboard. See the previous pages for the actual specifications of your motherboard.

## 1.2 Processor and Chipset Overview

Built upon the functionality and capability of the Dual AMD EPYC® 7002/7003 series processor in an SP3 socket. The H12DGO-6 motherboard offers maximum I/O expendability, energy efficiency, and data reliability in a 7nm process architecture, and is optimized for embedded storage solutions, networking applications, or cloud-computing platforms.

With support of the new microarchitecture 7nm process technology, the H12DGO-6 drastically increases system performance for a multitude of server applications.

The Dual AMD EPYC® 7002/7003 series processor supports the following features:

- ACPI Power Management Logic Support Rev. 6.2
- Adaptive Thermal Management/Monitoring
- PCIe 4.0 w/transfer rate of up to 16.0 GT/s
- System Management Bus (SMBus) Specification Version 3.1.1

## 1.3 Special Features

This section describes the health monitoring features of the H12DGO-6 motherboard. The motherboard has an onboard System Hardware Monitor chip that supports system health monitoring.

### **Recovery from AC Power Loss**

The Basic I/O System (BIOS) provides a setting that determines how the system will respond when AC power is lost and then restored to the system. You can choose for the system to remain powered off (in which case you must press the power switch to turn it back on), or for it to automatically return to the power-on state. See the Advanced BIOS Setup section for this setting. The default setting is Last State.

## 1.4 System Health Monitoring

This section describes the health monitoring features of the H12DGO-6 motherboard. The motherboard has an onboard chip that supports system health monitoring. Once a voltage becomes unstable, a warning is given or an error message is sent to the screen. The user can adjust the voltage thresholds to define the sensitivity of the voltage monitor.

### Onboard Voltage Monitors

The onboard voltage monitor will continuously scan crucial voltage levels. Once a voltage becomes unstable, it will give a warning or send an error message to the screen. Users can adjust the voltage thresholds to define the sensitivity of the voltage monitor. Real time readings of these voltage levels are all displayed in BMC.

### Fan Status Monitor with Firmware Control

PC health monitoring in the BIOS can check the RPM status of the cooling fans. The onboard CPU and chassis fans are controlled by Thermal Management.

### Environmental Temperature Control

The thermal control sensor monitors the CPU temperature in real time and will turn on the thermal control fan whenever the CPU temperature exceeds a user-defined threshold. The overheat circuitry runs independently from the CPU. Once the thermal sensor detects that the CPU temperature is too high, it will automatically turn on the thermal fans to prevent the CPU from overheating. The onboard chassis thermal circuitry can monitor the overall system temperature and alert the user when the chassis temperature is too high.

**Note:** To avoid possible system overheating, please be sure to provide adequate airflow to your system.

### System Resource Alert

This feature is available when used with SuperDoctor 5<sup>®</sup>. SuperDoctor 5 is used to notify the user of certain system events. For example, you can configure SuperDoctor 5 to provide you with warnings when the system temperature, CPU temperatures, voltages and fan speeds go beyond a predefined range.

## 1.5 ACPI Features

ACPI stands for Advanced Configuration and Power Interface. The ACPI specification defines a flexible and abstract hardware interface that provides a standard way to integrate power management features throughout a computer system including its hardware, operating system and application software. This enables the system to automatically turn on and off peripherals such as network cards, hard disk drives and printers.

In addition to enabling operating system-directed power management, ACPI also provides a generic system event mechanism for Plug and Play and an operating system-independent interface for configuration control. ACPI leverages the Plug and Play BIOS data structures while providing a processor architecture-independent implementation that is compatible with Windows Server 2019 operating systems.

## 1.6 Power Supply

As with all computer products, a stable power source is necessary for proper and reliable operation. It is even more important for processors that have high CPU clock rates. In areas where noisy power transmission is present, you may choose to install a line filter to shield the computer from noise. It is recommended that you also install a power surge protector to help avoid problems caused by power surges.

## 1.7 Super I/O

The Super I/O (Aspeed AST2600 chip) includes a data separator, write pre-compensation circuitry, decode logic, data rate selection, a clock generator, drive interface control logic and interrupt and DMA logic. The wide range of functions integrated onto the Super I/O greatly reduces the number of components required for interfacing with floppy disk drives.

The Super I/O provides one high-speed, 16550 compatible serial communication port (UART), which supports serial infrared communication. This UART includes a 16-byte send/receive FIFO, a programmable baud rate generator, complete modem control capability and a processor interrupt system. This UART provides legacy speed with baud rate of up to 115.2 Kbps as well as an advanced speed with baud rates of 250 K, 500 K, or 1 Mb/s, which support higher speed modems.

The Super I/O provides functions that comply with ACPI (Advanced Configuration and Power Interface), which includes support of legacy and ACPI power management through a SMI or SCI function pin. It also features auto power management to reduce power consumption.

The IRQs, DMAs and I/O space resources of the Super I/O can be flexibly adjusted to meet ISA PnP requirements, which support ACPI and APM (Advanced Power Management).

# Chapter 2

## Installation

### 2.1 Static-Sensitive Devices

Electrostatic Discharge (ESD) can damage electronic components. To prevent damage to your motherboard, it is important to handle it very carefully. The following measures are generally sufficient to protect your equipment from ESD.

#### Precautions

- Use a grounded wrist strap designed to prevent static discharge.
- Touch a grounded metal object before removing the board from the antistatic bag.
- Handle the board by its edges only; do not touch its components, peripheral chips, memory modules or gold contacts.
- When handling chips or modules, avoid touching their pins.
- Put the motherboard and peripherals back into their antistatic bags when not in use.
- For grounding purposes, make sure that your chassis provides excellent conductivity between the power supply, the case, the mounting fasteners and the motherboard.
- Use only the correct type of CMOS onboard battery as specified by the manufacturer. Do not install the CMOS battery upside down, which may result in a possible explosion.

#### Unpacking

The motherboard is shipped in antistatic packaging to avoid static damage. When unpacking the motherboard, make sure that the person handling it is static protected.

## 2.2 Motherboard Installation

All motherboards have standard mounting holes to fit different types of chassis. Make sure that the locations of all the mounting holes for both the motherboard and the chassis match. Although a chassis may have both plastic and metal mounting fasteners, metal ones are highly recommended because they ground the motherboard to the chassis. Make sure that the metal standoffs click in or are screwed in tightly.



Philips Screwdriver (1)



Philips Screws (13)



Standoffs (13)  
Only if Needed

### Tools Needed

### Location of Mounting Holes

#### Notes:

1. To avoid damaging the motherboard and its components, please do not use a force greater than 8 lb/inch on each mounting screw during motherboard installation.
2. Some components are very close to the mounting holes. Please take precautionary measures to avoid damaging these components when installing the motherboard to the chassis.

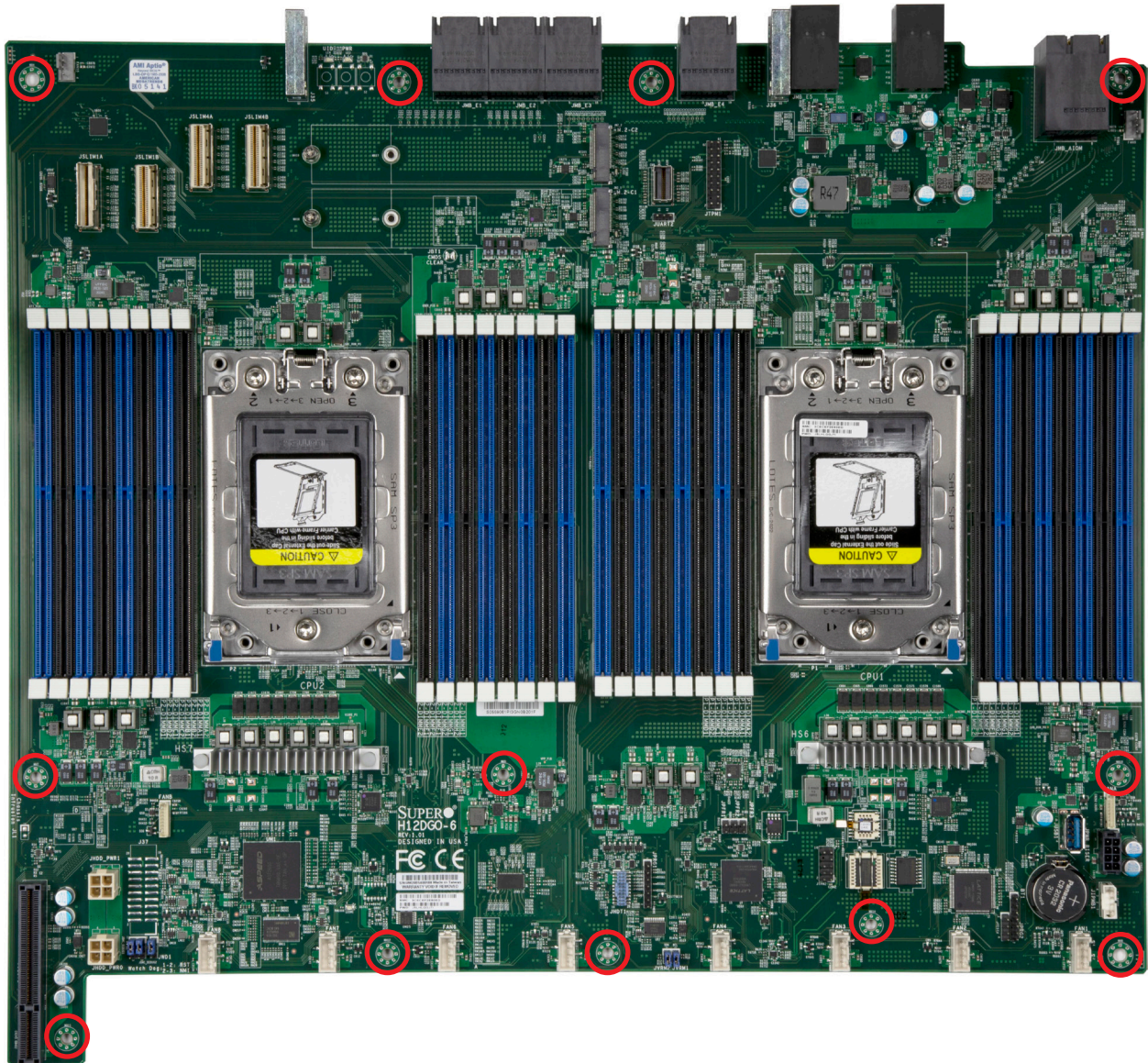
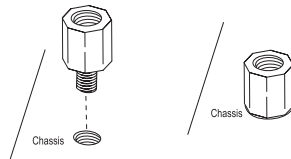

Figure 2-1. Motherboard Mounting Holes

## Installing the Motherboard

**Note:** Always connect the power cord last, and always remove it before adding, removing, or changing any hardware components. Install the I/O shield into the chassis.

1. Locate the mounting holes on the motherboard. See the previous page for the location.
2. Locate the matching mounting holes on the chassis. Align the mounting holes on the motherboard against the mounting holes on the chassis.
3. Install standoffs in the chassis as needed.



4. Install the motherboard into the chassis carefully to avoid damaging other motherboard components.
5. Using the Phillips screwdriver, insert a Phillips head #6 screw into a mounting hole on the motherboard and its matching mounting hole on the chassis.

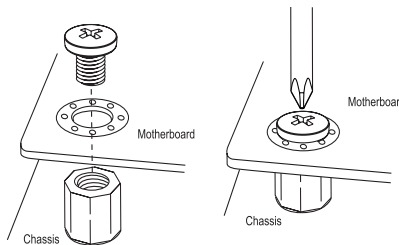

6. Repeat Step 5 to insert #6 screws into all mounting holes.
7. Make sure that the motherboard is securely placed in the chassis.

**Note:** Images displayed are for illustration only. Your chassis or components might look different from those shown in this manual.

## 2.3 Processor and Heatsink Installation

**Warning:** When handling the processor package, avoid placing direct pressure on the label area of the fan.

### Important:

- For the Processor/Heatsink installation you need to use a T20 screwdriver when opening/closing the CPU socket.
- Always connect the power cord last, and always remove it before adding, removing or changing any hardware components. Make sure that you install the processor into the CPU socket before you install the CPU heatsink.
- If you buy a CPU separately, make sure that you use an AMD-certified multi-directional heatsink only.
- Make sure to install the motherboard into the chassis before you install the CPU heatsink.
- When receiving a motherboard without a processor pre-installed, make sure that the plastic CPU socket cap is in place and none of the socket pins are bent; otherwise, contact your retailer immediately.
- Refer to the Supermicro website for updates on CPU support.

### Installing the Processor and Heatsink

1. Unscrew the screws holding down Force Frame in the sequence of 3-2-1. The screws are numbered on the Force Frame next to each screw hole.

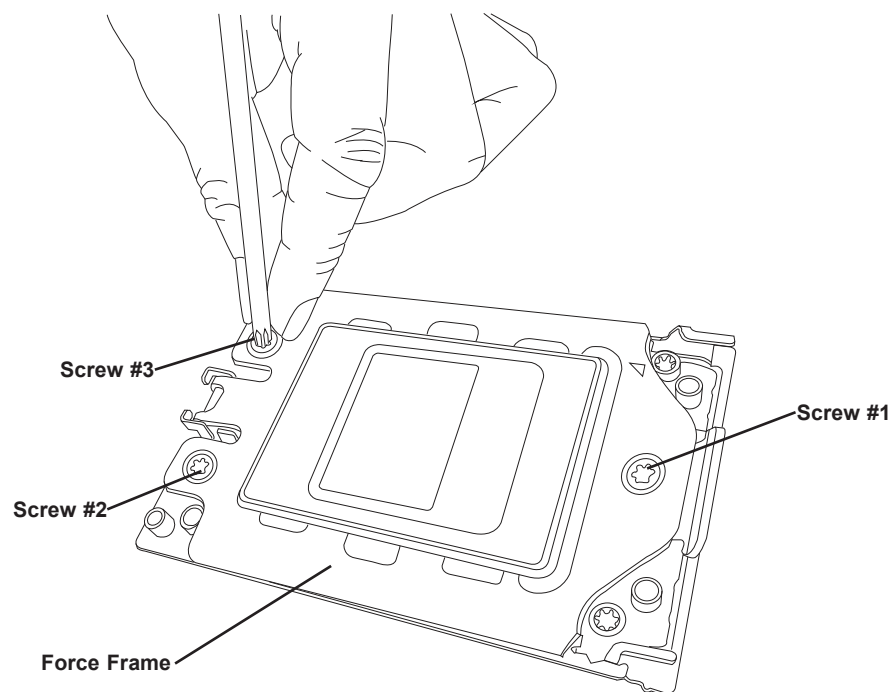

2. The spring-loaded Force Frame will raise up after the last screw securing it (#1) is removed. Gently allow it to lift up to its stopping position.

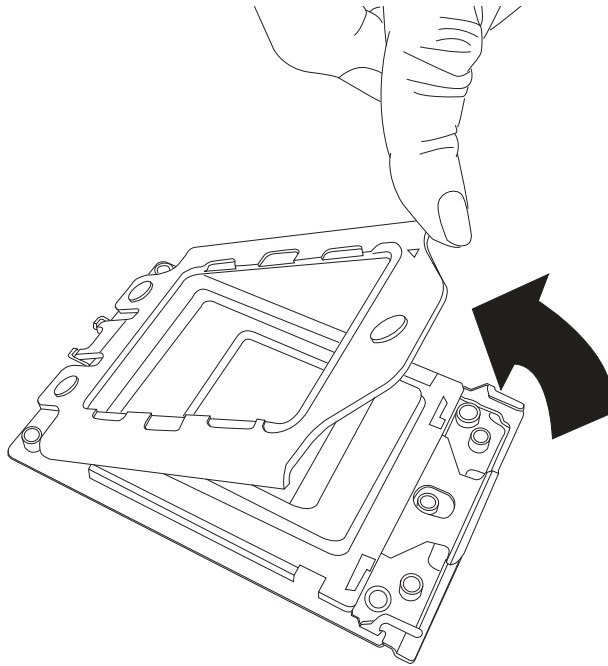

3. Lift the Rail Frame up by gripping the lift tabs near the front end of the rail frame. While keeping a secure grip of the Rail Frame, lift it to a position so you can do the next step of removing the External Cap.
4. **Note:** The Rail Frame is spring loaded, so keep a secure grip on it as you lift it so it does not snap up.

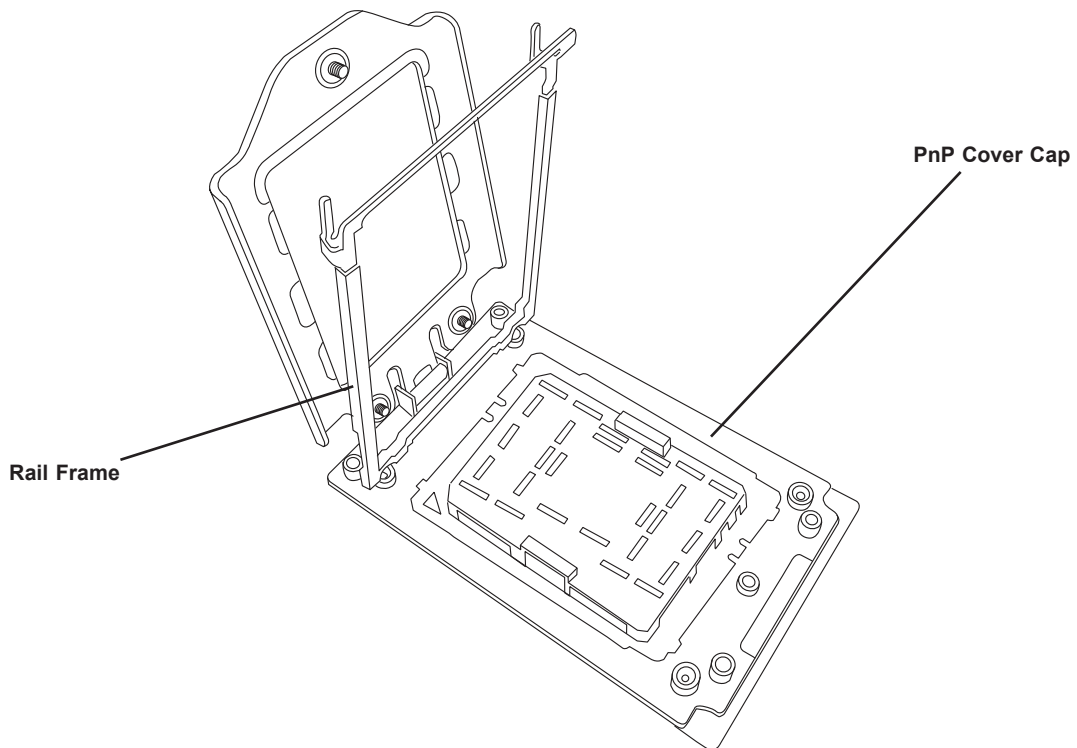

5. Remove the External Cap from the Rail Frame by pulling it upwards through the rail guides on the Rail Frame.

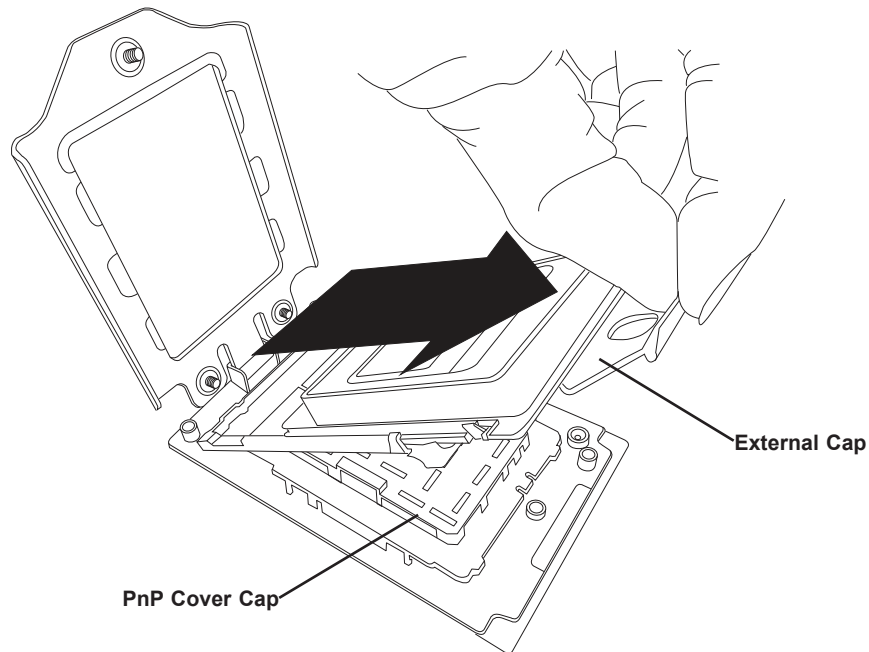

6. The CPU Package is shipped from the factory with the Carrier Frame pre-assembled. Grip the handle of the Carrier Frame/CPU Package assembly from its shipping tray, and while gripping the handle, align the flanges of the Carrier Frame onto the rails of the Rail Frame so its pins will be at the bottom when the Rail Frame is lowered later.
7. Slide the Carrier Frame/CPU Package downwards to the bottom of the Rail Frame. Ensure the flanges are secure on the rails as you lower it downwards.

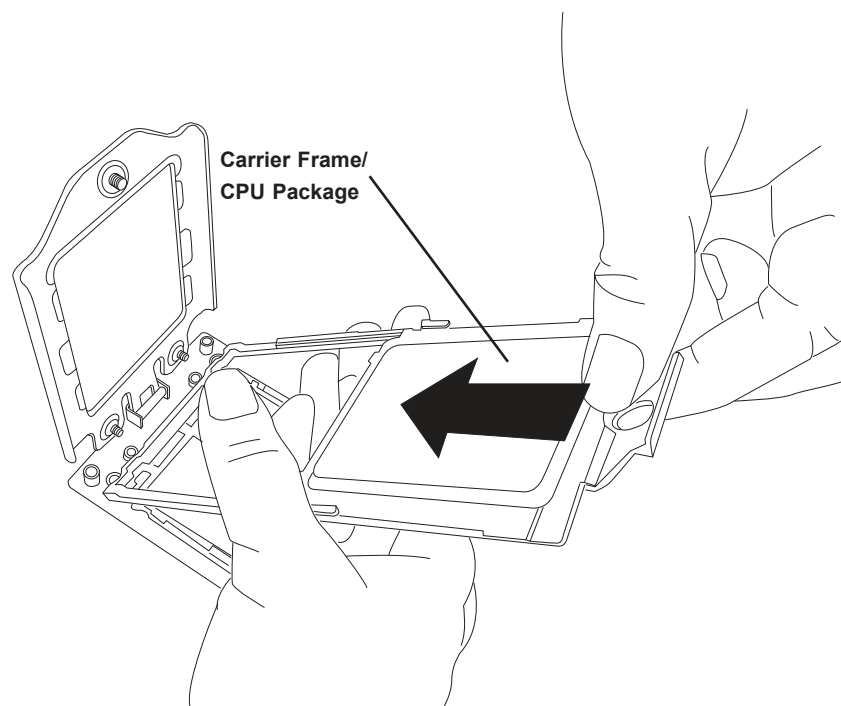

**Note:** You can only install the CPU inside the socket in one direction with the handle at the top. Make sure that it is properly inserted into the CPU socket before closing the Rail Frame plate. If it doesn't close properly, do not force it as it may damage your CPU. Instead, open the Rail Frame plate again, and double-check that the CPU is aligned properly.

8. Lift up the Rail Frame till it securely rests in upright position. Then remove the PnP Cover Cap from the CPU socket below. Grip the two lift tabs marked "Remove" at the middle of the cap and pull vertically upwards to remove the PnP Cover Cap.

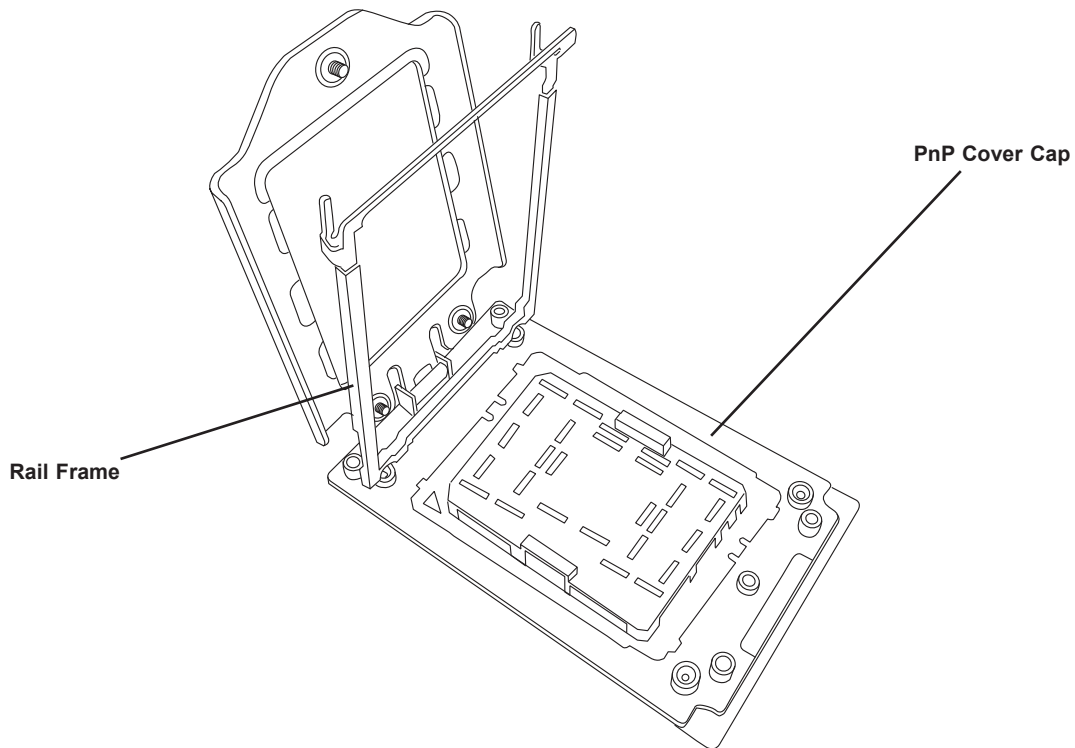

**Warning!** The exposed socket contacts are extremely vulnerable and can be damaged easily. Do not touch or drop objects onto the contacts and be careful removing the PnP Cover Cap and when placing the Rail Frame over the socket.

9. Gently lower the Rail Frame down onto the socket until the latches on the Rail Frame engage with the Socket housing, and it rests in place. DO NOT force it into place!

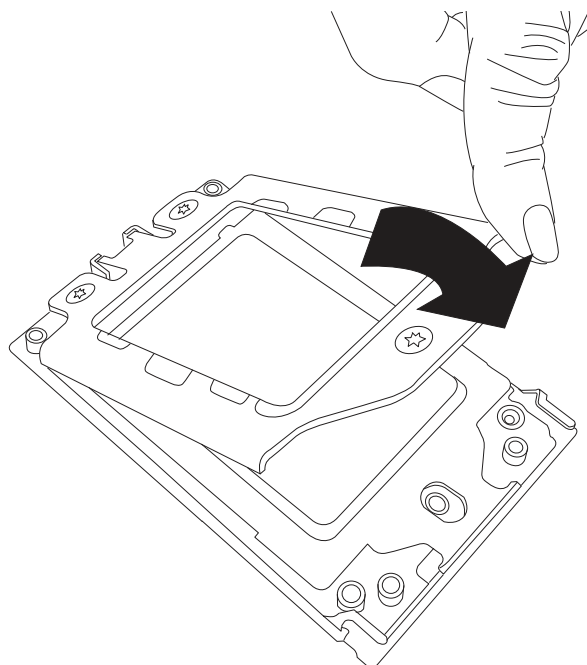

10. Gently lower the Force Frame down onto the Rail Frame and hold it in place until it is seated in the Socket housing. Note that the Force Frame is spring loaded and has to be held in place before it is secured. **Important: Use a torque screwdriver, set it at 16.1 kgf-cm (14.0 lbf-in) with a Torx T20 screw head bit, to prevent damage to the CPU.**

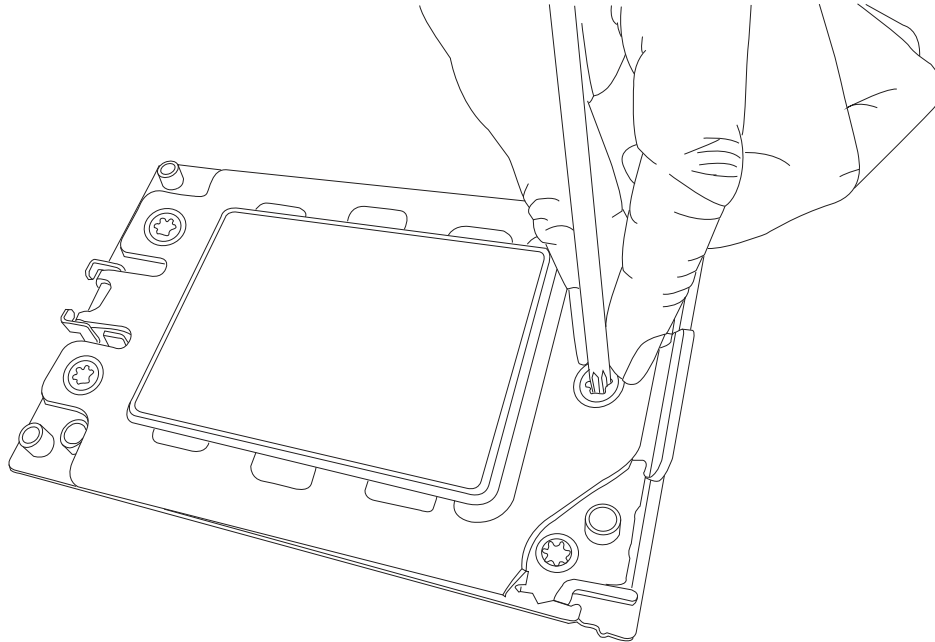

11. Place and re-screw the screws in the reverse order to the way you removed them (holes 1-2-3 in order). When finished, the Force Frame will be secure over both the Rail Frame and CPU Package.

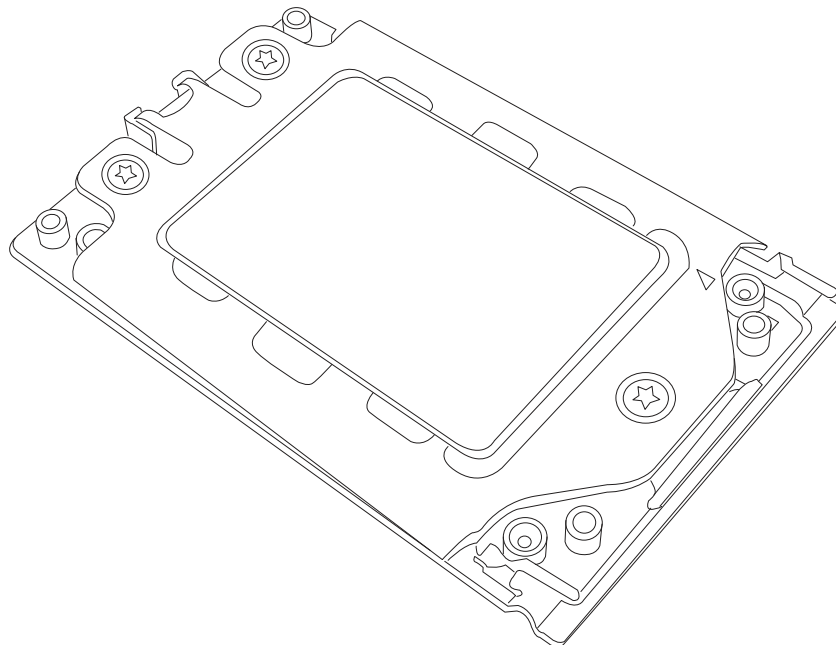

- After the Force Frame is secured and the CPU package is in place, now you must install the heatsink to the frame. Lower the heatsink down till it rests securely over the four screw holes on CPU Package on the socket frame.

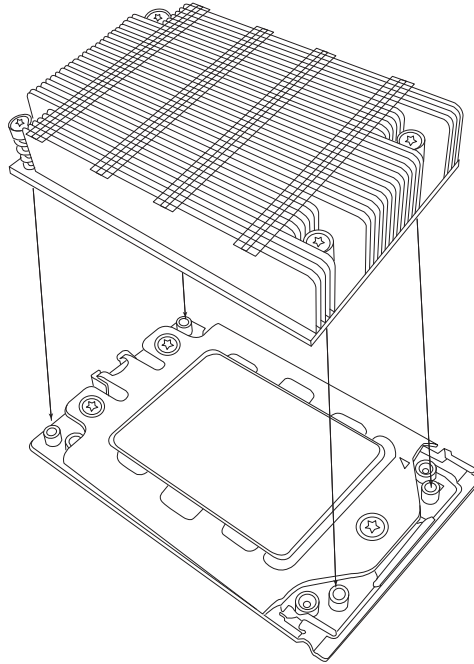

- Using a diagonal pattern, tighten the four screws down on the heatsink in a clockwise fashion till it is secure. The heatsink will now be secured and you have finished installing the processor and heatsink onto the motherboard. Repeat this procedure for any remaining CPU sockets on the Motherboard.

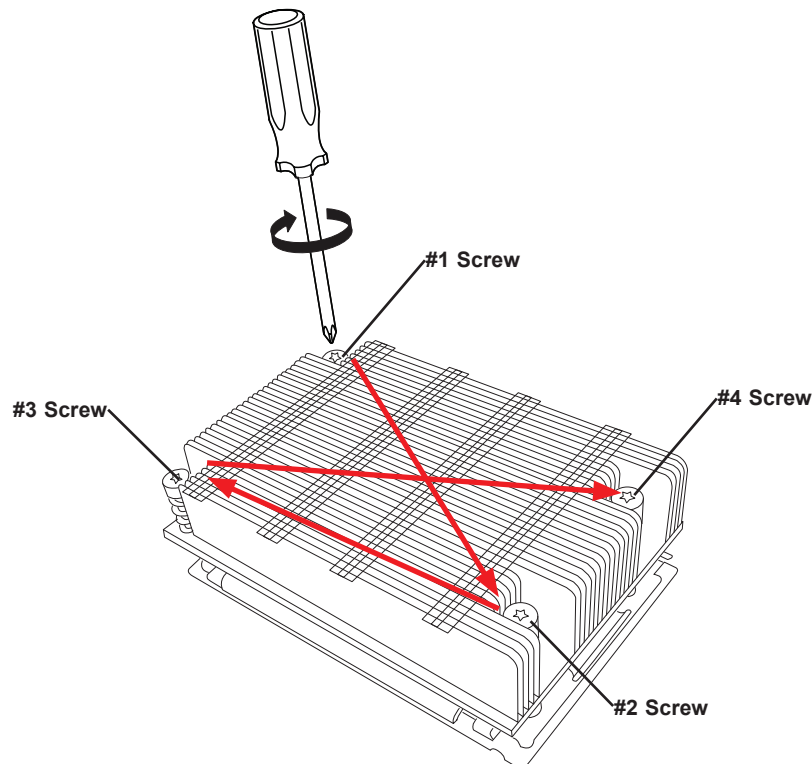

### **Un-installing the Processor and Heatsink**

1. Remove the heatsink attached to the top of the CPU Package by reversing the installation procedure.
2. Clean the Thermal grease left by the heatsink on the CPU package lid to limit the risk of it contaminating the CPU package land pads or contacts in the socket housing.
3. Reverse the procedure for installing the Force Frame onto the socket, unscrewing the plate in the 3-2-1 screw order and lift the Force Frame to the vertical position.
4. Lift the Rail Frame using the lift tabs near the front end of the Rail Frame. Note that the Rail Frame is spring loaded, so be careful lifting it up into a vertical position.
5. Grip the handle of the Carrier Frame and pull upwards to extract it from the Rail Frame. Return the Carrier Frame/CPU Package to its original shipping container.
6. Grip the handle on the External Cap and return it to the Rail Frame sliding it downwards till it rests in the frame.
7. Gripping the Rail Frame, rotate it downwards till it rests above and locks over the socket housing in its horizontal position.
8. Push and rotate down the Force Frame till it is over the External Cap and Rail Frame into a horizontal position.
9. While holding down the Force Frame, secure it back to the socket frame by securing screw 1 in place. Note that without a CPU Package in place, it is not necessary to tighten down screws 2 and 3 at this time.

## 2.4 Memory Support and Installation

**Note:** Check the Supermicro website for recommended memory modules.

**Important:** Exercise extreme care when installing or removing DIMM modules to prevent any possible damage.

### Memory Support

The H12DGO-6 supports up to 8TB of ECC DDR4 3200 MHz speed, RDIMM/LRDIMM/3DS/NVDIMM memory in thirty-two slots. Refer to the table below for additional memory information.

Processors and their Corresponding Memory Modules																
CPU#	Channel 1		Channel 2		Channel 3		Channel 4		Channel 5		Channel 6		Channel 7		Channel 8	
<b>8 DIMMS</b>																
CPU1		A2		B2		C2		D2		E2		F2		G2		H2
<b>16 DIMMS</b>																
CPU1	A1	A2	B1	B2	C1	C2	D1	D2	E1	E2	F1	F2	G1	G2	H1	H2
<b>16 DIMMS</b>																
CPU1		A2		B2		C2		D2		E2		F2		G2		H2
CPU2		A2		B2		C2		D2		E2		F2		G2		H2
<b>32 DIMMS</b>																
CPU1	A1	A2	B1	B2	C1	C2	D1	D2	E1	E2	F1	F2	G1	G2	H1	H2
CPU2	A1	A2	B1	B2	C1	C2	D1	D2	E1	E2	F1	F2	G1	G2	H1	H2

Populating RDIMM/RDIMM 3DS/LRDIMM/LRDIMM 3DS DDR4 Memory Modules with 7002/7003 Processors					
Type	DIMM Population		Maximum DIMM Capacity (GB)		Maximum Frequency (MHz)
	DIMM1	DIMM2	1 Channel	8 Channel	
RDIMM		1R	32GB	256GB	3200
	1R	1R	64GB	512GB	2933
		2R or 2DR	64GB	512GB	3200
	1R	2R or 2DR	96GB	768GB	2933
	2R or 2DR	2R or 2DR	128GB	1TB	2933
LRDIMM dual die package		4DR	128GB	1TB	3200
	4DR	4DR	256GB	2TB	2933
LRDIMM 3DS		2S2R	128GB	1TB	3200
		2S4R	256GB	2TB	3200
	2S2R	2S2R	256GB	2TB	2933
	2S2R	2S4R	384GB	3TB	2933
	2S4R	2S4R	512GB	4TB	2933
3DS RDIMM		2S2R	128GB	1TB	2933
	2S2R	2S2R	256GB	2TB	2666
		2S4R	256GB	2TB	2933
	2S2R	2S4R	384GB	3TB	2666
	2S4R	2S4R	512GB	4TB	2666

## DIMM Module Population Sequence

When installing memory modules, the DIMM slots should be populated in the following order: DIMMA2, DIMMB2, DIMMC2, DIMMD2, DIMME2, DIMMF2, DIMMG2, DIMMH2, then DIMMA1, DIMMB1, DIMMC1, DIMMD1, DIMME1, DIMMF1, DIMMG1, DIMMH1.

- The blue slots must be populated first.
- Always use DDR4 DIMM modules of the same type, size and speed.
- The motherboard will support odd-numbered modules (1 or 3 modules installed). However, to achieve the best memory performance, fully populate the motherboard with validated memory modules.

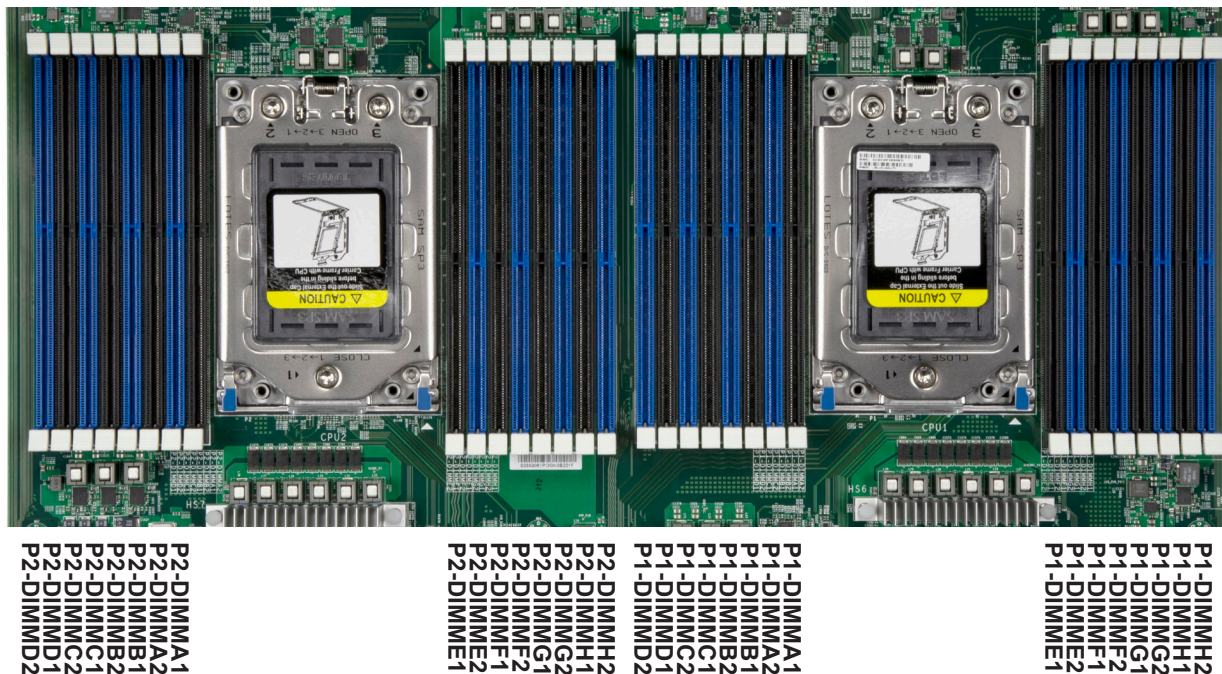
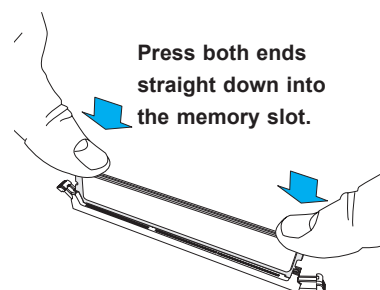
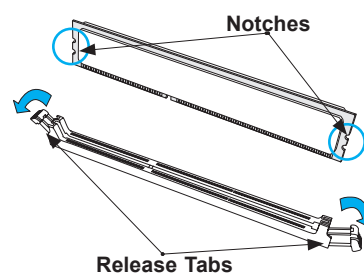
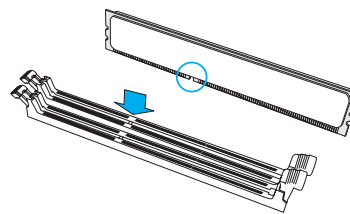

Figure 2-2. DIMM Numbering

## DIMM Installation

1. Insert the desired number of DIMMs into the memory slots, starting with DIMMA2, DIMMB2, DIMMC2, DIMMD2, DIMME2, DIMMF2, DIMMG2, DIMMH2, then DIMMA1, DIMMB1, DIMMC1, DIMMD1, DIMME1, DIMMF1, DIMMG1, DIMMH1. For best performance, please use the memory modules of the same type and speed.
2. Push the release tabs outwards on both ends of the DIMM slot to unlock it.
3. Align the key of the DIMM module with the receptive point on the memory slot.
4. Align the notches on both ends of the module against the receptive points on the ends of the slot.
5. Press both ends of the module straight down into the slot until the module snaps into place.
6. Press the release tabs to the lock positions to secure the DIMM module into the slot.



## DIMM Removal

Press both release tabs on the ends of the DIMM module to unlock it. Once the DIMM module is loosened, remove it from the memory slot.

## 2.5 Connectors

### Backplane 12V and 5V 8-pin Power Connectors

JHDD\_PWR0 and JHDD\_PWR1 are 4-pin 12V and 5V DC power inputs for the system's backplane. Refer to the table below for pin definitions.

Backplane 8-pin Power Pin Definitions			
Pin#	Definition	Pin#	Definition
1	Ground	3	+5V
2	Ground	4	+12V

### TPM Header/Port 80 Connector

The JTPM1 header is used to connect a Trusted Platform Module (TPM), which is available from a third-party vendor. A TPM is a security device that supports encryption and authentication in hard drives. It enables the motherboard to deny access if the TPM associated with the hard drive is not installed in the system.

Please go to the following link for more information on TPM: <http://www.supermicro.com/manuals/other/TPM.pdf>.

Trusted Platform Module Header Pin Definitions			
Pin#	Definition	Pin#	Definition
1	LCLK	2	GND
3	LFRAME#	4	
5	LRESET#	6	NC
7	LAD3	8	LAD2
9	3.3V	10	LAD1
11	LAD0	12	GND
13	NC	14	NC
15	3.3V_STBY	16	SERIRQ
17	GND	18	NC
19	NC	20	NC

### SATA Ports

The H12DGO-6 supports four SATA 3.0 ports through CN9 port and HDD backplane board BPN-NVMe4-F418-B6S6 with a specific cable.

## NVM Express Connections

Two NVM Express ports are located on the serverboard (from CPU2). These ports provide high-speed, low-latency PCIe 4.0 x4 connections directly from the CPU to NVMe Solid State Drives (SSD). This greatly increases SSD data-throughput performance and significantly reduces PCIe latency by simplifying driver/software requirements resulted from direct PCIe interface from the CPU to the NVMe SSD drives.

## Fan Headers

There are eight fan headers on the motherboard. These are 4-pin fan headers; pins 1-3 are backward compatible with traditional 3-pin fans. The onboard fan speeds are controlled by Fan Mode in the BMC. When using Fan Mode setting, please use all 4-pin fans.

Fan Header Pin Definitions	
Pin#	Definition
1	Ground (Black)
2	+12V (Red)
3	Tachometer (Yellow)
4	PWM control (Blue)

## IPMB System Management Bus Header

A System Management Bus header for IPMI 2.0 is located at JIPMB1. Connect the appropriate cable here to use the IPMB I<sup>2</sup>C connection on your system.

IPMB Header Pin Definitions	
Pin#	Definition
1	Data
2	Ground
3	Clock
4	No Connection

## 2.6 Jumper Settings

### How Jumpers Work

To modify the operation of the motherboard, jumpers can be used to choose between optional settings. Jumpers create shorts between two pins to change the function of the connector. Pin 1 is identified with a square solder pad on the printed circuit board. See the diagram below for an example of jumping pins 1 and 2. Refer to the motherboard layout page for jumper locations.

**Note:** On two-pin jumpers, "Closed" means the jumper is on and "Open" means the jumper is off the pins.

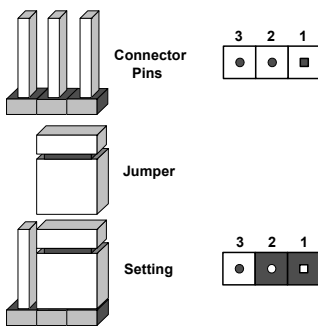

### CMOS Clear

JBT1 is used to clear CMOS, which will also clear any passwords. Instead of pins, this jumper consists of contact pads to prevent accidentally clearing the contents of CMOS.

#### To Clear CMOS

1. First power down the system and unplug the power cord(s).
2. Remove the cover of the chassis to access the motherboard.
3. Remove the CMOS battery from the motherboard.
4. Short the CMOS pads with a metal object such as a small screwdriver for at least four seconds.
5. Remove the screwdriver (or shorting device).
6. Re-install the CMOS battery on the motherboard.
7. Replace the cover, reconnect the power cord(s), and power on the system.

**Note:** Clearing CMOS will also clear all passwords.



## Watch Dog

JWD1 controls the Watch Dog function. Watch Dog is a monitor that can reboot the system when a software application hangs. Jumping pins 1-2 will cause Watch Dog to reset the system if an application hangs. Jumping pins 2-3 will generate a non-maskable interrupt (NMI) signal for the application that hangs. Watch Dog must also be enabled in BIOS. The default setting is Reset.

**Note:** When Watch Dog is enabled, the user needs to write their own application software to disable it.

Watch Dog Jumper Settings	
Jumper Setting	Definition
Pins 1-2	Reset (Default)
Pins 2-3	NMI
Open	Disabled

## 2.7 LED Indicators

### LAN Port LEDs

The IPMI Ethernet port has two LED indicators. The Activity LED is yellow and indicates connection and activity. The Link LED may be green, amber, or off to indicate the speed of the connection. Refer to the tables below for more information.

LAN1/2 LED (Connection Speed Indicator)	
LED Color	Definition
Off	10 Mb/s
Green	100 Mb/s
Amber	1 Gb/s

Activity Indicator		
Color	Status	Definition
Off	No Connection	
Yellow	Flashing	Active

### Front Power LED

When this LED is lit, it means system is in power-on state, and the onboard power status is ok. Turn off the system and unplug the power cord before removing or installing components.

Front Power LED Indicator	
LED Color	Definition
Off	System Off (power cable not connected)
Green	System On, Power OK

### BMC Heartbeat LED

A BMC Heartbeat LED is located at LED2 on the serverboard. When LED2 is blinking, BMC functions normally. See the table below for more information.

BMC Heartbeat LED States		
Color	State	Definition
Green	Solid On	BMC is not ready.
Green	Blinking	BMC Normal
Green	Fast Blinking	BMC: Initializing

### Unit Identified LED

The front UID LED is located next to the UID switch. The UID indicators provide easy identification of a system unit that may be in need of service.

UID LED Status	
LED State	Status
Solid On	Local Unit Identified
Blinking	Remote Unit Identified

# Chapter 3

## Troubleshooting

### 3.1 Troubleshooting Procedures

Use the following procedures to troubleshoot your system. If you have followed all of the procedures below and still need assistance, refer to the 'Technical Support Procedures' and/or 'Returning Merchandise for Service' section(s) in this chapter. Always disconnect the AC power cord before adding, changing or installing any non hot-swap hardware components.

#### **Before Power On**

1. Check that LED2 is blinking before the motherboard is turned on.
2. Check that LED6 on the motherboard is on.
3. Make sure that the power connector is connected to your power supply.
4. Make sure that no short circuits exist between the motherboard and chassis.
5. Disconnect all cables from the motherboard, including those for the keyboard and mouse.
6. Remove all add-on cards.
7. Install a CPU, a heatsink\*, and at least one DIMM on the motherboard. Check all jumper settings properly. \*Make sure that the heatsink is fully seated.
8. Use the correct type of onboard CMOS battery (CR2032) as recommended by the manufacturer. To avoid possible explosion, do not install the CMOS battery upside down.

#### **No Power**

1. Make sure that no short circuits exist between the motherboard and the chassis.
2. Verify that all jumpers are set to their default positions.
3. Check that the 115V/230V switch on the power supply is properly set.
4. Turn the power switch on and off to test the system.

5. The CMOS battery on your motherboard may be old. Check to verify that it still supplies ~3V DC. If it does not, replace it with a new one.

### **No Video**

1. Check that the VGA cable is connected properly, and the monitor is on.
2. Check if you follow the guidelines to install the memory module (see DIMM Module Population in chapter 2).
3. Reseat the memory DIMM module.

### **System Boot Failure**

If the system does not display POST (Power-On-Self-Test) or does not respond after the power is turned on, check the following:

1. Clear the CMOS settings by unplugging the power cord and contacting both pads on the CMOS Clear Jumper (JBT1). Refer to chapter 2.
2. Remove all components from the motherboard, especially the DIMM modules.
3. Turn on the system with only one DIMM module installed. If the system boots, check for bad DIMM modules or slots by following the Memory Errors Troubleshooting procedure in this Chapter.

### **Memory Errors**

1. Make sure that the DIMM modules are properly and fully installed.
2. Confirm that you are using the correct memory. Also, it is recommended that you use the same memory type and speed for all DIMMs in the system. See Section 2.4 for memory details.
3. Check for bad DIMM modules or slots by swapping modules between slots and noting the results.
4. Check the power supply voltage 115V/230V switch.

## What to do if the System is Losing the Setup Configuration

1. Make sure that you are using a high quality power supply. A poor quality power supply may cause the system to lose the CMOS setup information. Refer to Section 1 for details on power supplies.
2. The battery on your motherboard may be old. Check to verify that it still supplies ~3V DC. If it does not, replace it with a new one.
3. If the above steps do not fix the setup configuration problem, contact your vendor for repairs.

## When the System Becomes Unstable

### ***A. If the system becomes unstable during or after OS installation, check the following:***

1. CPU/BIOS support: Make sure that your CPU is supported and that you have the latest BIOS installed in your system.
2. Memory support: Make sure that the memory modules are supported by testing the modules using memtest86 or a similar utility.  
**Note:** Refer to the product page on our website at <http://www.supernmicro.com> for memory and CPU support and updates.
3. HDD support: Make sure that all hard disk drives (HDDs) work properly. Replace the bad HDDs with good ones.
4. System cooling: Check the system cooling to make sure that all heatsink fans and CPU/system fans, etc., work properly. Check the hardware monitoring settings in the IPMI to make sure that the CPU and system temperatures are within the normal range. Also check the front panel Overheat LED and make sure that it is not on.
5. Adequate power supply: Make sure that the power supply provides adequate power to the system. Make sure that all power connectors are connected. Please refer to our website for more information on the minimum power requirements.
6. Proper software support: Make sure that the correct drivers are used.

### ***B. If the system becomes unstable before or during OS installation, check the following:***

1. Source of installation: Make sure that the devices used for installation are working properly, including boot devices such as CD/DVD and CD/DVD-ROM.
2. Cable connection: Check to make sure that all cables are connected and working properly.
3. Using the minimum configuration for troubleshooting: Remove all unnecessary components (starting with add-on cards first), and use the minimum configuration (but

with a CPU and a memory module installed) to identify the trouble areas. Refer to the steps listed in Section A above for proper troubleshooting procedures.

4. Identifying bad components by isolating them: If necessary, remove a component in question from the chassis, and test it in isolation to make sure that it works properly. Replace a bad component with a good one.
5. Check and change one component at a time instead of changing several items at the same time. This will help isolate and identify the problem.
6. To find out if a component is good, swap this component with a new one to see if the system will work properly. If so, then the old component is bad. You can also install the component in question in another system. If the new system works, the component is good and the old system has problems.

## 3.2 Technical Support Procedures

Before contacting Technical Support, please take the following steps. Also, note that as a motherboard manufacturer, we do not sell directly to end-users, so it is best to first check with your distributor or reseller for troubleshooting services. They should know of any possible problem(s) with the specific system configuration that was sold to you.

1. Please review the 'Troubleshooting Procedures' and 'Frequently Asked Questions' (FAQs) sections in this chapter or see the FAQs on our website before contacting Technical Support.
2. BIOS upgrades can be downloaded from our website.  
**Note:** Not all BIOS can be flashed depending on the modifications to the boot block code.
3. If you still cannot resolve the problem, include the following information when contacting us for technical support:
  - Motherboard model and PCB revision number
  - BIOS release date/version (this can be seen on the initial display when your system first boots up)
  - System configuration

An example of a Technical Support form is posted on our website.

Distributors: For immediate assistance, please have your account number ready when contacting our technical support department by e-mail.

### 3.3 Frequently Asked Questions

**Question: What type of memory does my motherboard support?**

**Answer:** The H12DGO-6 motherboard supports up to 8TB of ECC DDR4 3200 MHz speed, RDIMM/LRDIMM/3DS/NVDIMM memory in thirty-two (32) slots. See Section 2.4 for details on installing memory.

**Question: How do I update my BIOS?**

**Answer:** It is recommended that you **do not** upgrade your BIOS if you are not experiencing any problems with your system. Updated BIOS files are located on our website at <http://www.supermicro.com>. Please check our BIOS warning message and the information on how to update your BIOS on our website. Select your motherboard model and download the BIOS file to your computer. Also, check the current BIOS revision to make sure that it is newer than your BIOS before downloading. You can choose from the zip file and the .exe file. If you choose the zip BIOS file, please unzip the BIOS file onto a bootable USB device. Run the batch file using the format FLASH.BAT filename.rom from your bootable USB device to flash the BIOS. Then, your system will automatically reboot.

**Question: Why can't I turn off the power using the momentary power on/off switch?**

**Answer:** The instant power off function is controlled in BIOS by the Power Button Mode setting. When the On/Off feature is enabled, the motherboard will have instant off capabilities as long as the BIOS has control of the system. When the 4 Seconds Override feature is enabled or when the BIOS is not in control such as during memory count (the first screen that appears when the system is turned on), the momentary on/off switch must be held for more than four seconds to shutdown the system. This feature is required to implement the ACPI features on the motherboard.

**Question: For the AMD EPYC platform, we found that the Windows Server 2012/2016 OS would not install properly. It however works fine with Linux OS, any suggestions?**

**Answer:** This issue is due to Windows server OS' compatibility with the virtualization function, we suggest to disable IOMMU (Input/Output Memory Management Unit) before installing the Windows Server OS. After installing the OS and hot fix update is finished, then you could enable the IOMMU in BIOS.

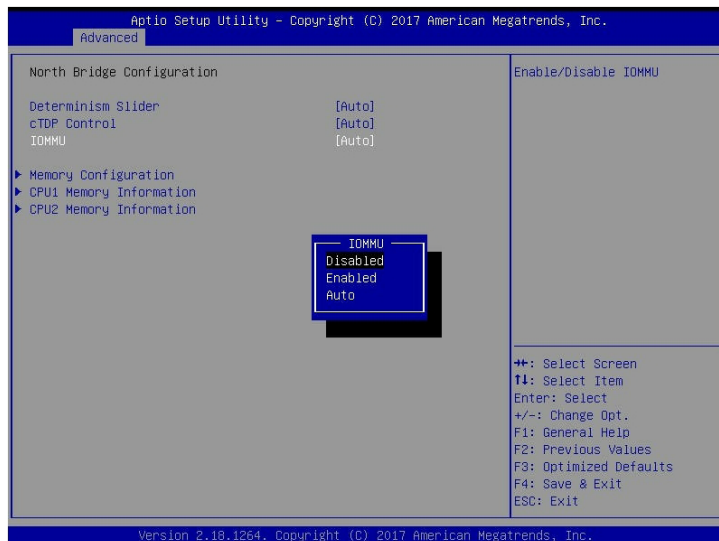

BIOS >> Advanced >> NB Configuration >> IOMMU >> Change from Auto to Disabled.

Microsoft KB: 4022723

Enabled machines with AMD I/O Virtualization Technology (IOMMU) to boot without BIOS restriction.

<https://support.microsoft.com/en-us/help/4022723/windows-10-update-kb4022723>

**Question: Why did the system freeze and fail to begin installation when I tried to install Windows Server 2016?**

**Answer:** Windows Sever 2016 support is limited to less than 255 logical processors, and it does not support x2APIC. Follow the steps to solve the problem.

1. Disable SMT in BIOS. (BIOS >> Advanced >> CPU Configuration >> SMT Control >> Disabled)
2. Set the option of Local APIC Mode to be xAPIC in BIOS. (BIOS >> Advanced >> CPU Configuration >> Local APIC Mode >> xAPIC)
3. Install Windows Server 2016 again.

**Question: Why did I fail to install Windows Server 2019 on a system with more than 255 logical processors?**

**Answer:** Follow the steps to solve the problem.

1. Disable SMT in BIOS. (BIOS >> Advanced >> CPU Configuration >> SMT Control >> Disabled)
2. Enable IOMMU in BIOS. (BIOS>>Advanced>>NB Configuration >>IOMMU>>Enable)
3. Install Windows Server 2019.
4. Install any required updates to ensure your installed Windows Server 2019 is up to date.
5. Ensure patch KB4512534 is now installed, reboot the system, and enter the BIOS setup utility.
6. Set the option of Local APIC Mode to be x2APIC in BIOS. (BIOS >> Advanced >> CPU Configuration >> Local APIC Mode >> x2APIC)
7. Enable SMP in BIOS. (BIOS >> Advanced >> CPU Configuration >> SMT Control >> Enabled)
8. All logical cores are available for use.

**Question: Why are not all 256 CPU cores displayed on Linux?**

**Answer:** This issue is due to that your Linux kernel does not support 256 CPU cores. Make sure that your Linux kernel version is equal to or higher than 4.19x, and enable IOMMU (Input/Output Memory Management Unit) in BIOS.

**Question: When I ran the executable file setup.exe to install the AMD SP3 I/O driver on Windows, the following message appeared:**

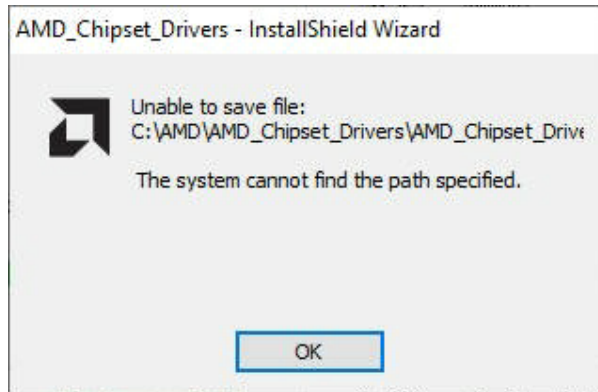

**Answer:** It happens in some environments. To solve this problem, click OK and save the installation package to the location you specify. The driver is then installed automatically.

**Question: The DIMM slots (DIMM1 as blue and DIMM2 as black) in the H12DGO-6 R1.01 layout look different from those in the other H12 products. Does the motherboard design differ?**

**Answer:** The DIMM slot colors on the motherboard were mistakenly reversed and have been corrected in H12DGO-6 R1.01A. Please note that black DIMMs are designated as DIMM1 and blue DIMMs as DIMM2.

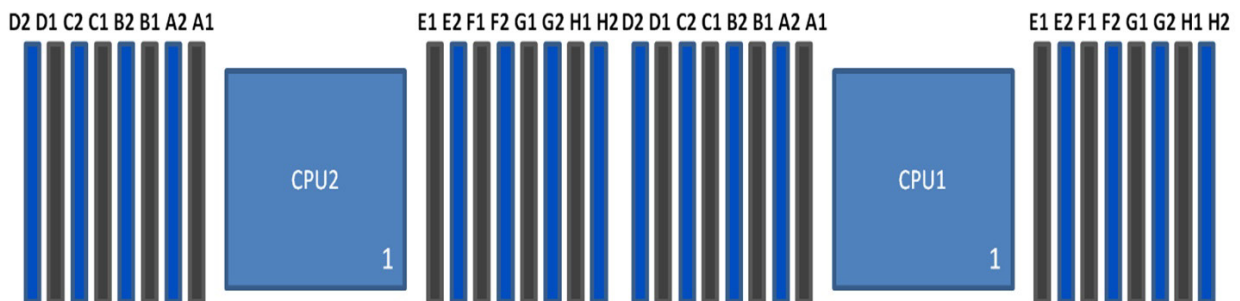

## 3.4 Returning Merchandise for Service

A receipt or copy of your invoice marked with the date of purchase is required before any warranty service will be rendered. You can obtain service by calling your vendor for a Returned Merchandise Authorization (RMA) number. When returning to the manufacturer, the RMA number should be prominently displayed on the outside of the shipping carton and mailed prepaid or hand-carried. Shipping and handling charges will be applied for all orders that must be mailed when service is complete.

For faster service, RMA authorizations may be requested online (<http://www.supermicro.com/support/rma/>).

This warranty only covers normal consumer use and does not cover damages incurred in shipping or from failure due to the alteration, misuse, abuse or improper maintenance of products.

During the warranty period, contact your distributor first for any product problems.

## 3.5 Battery Removal and Installation

### Battery Removal

To remove the onboard battery, follow the steps below:

1. Power off your system and unplug your power cable.
2. Locate the onboard battery as shown below.
3. Using a tool such as a pen or a small screwdriver, push the battery lock outwards to unlock it. Once unlocked, the battery will pop out from the holder.
4. Remove the battery.

### Proper Battery Disposal

Please handle used batteries carefully. Do not damage the battery in any way; a damaged battery may release hazardous materials into the environment. Do not discard a used battery in the garbage or a public landfill. Please comply with the regulations set up by your local hazardous waste management agency to dispose of your used battery properly.

## Battery Installation

1. To install an onboard battery, follow the steps 1 & 2 above and continue below:
2. Identify the battery's polarity. The positive (+) side should be facing up.
3. Insert the battery into the battery holder and push it down until you hear a click to ensure that the battery is securely locked.

**Important:** When replacing a battery, be sure to only replace it with the same type.

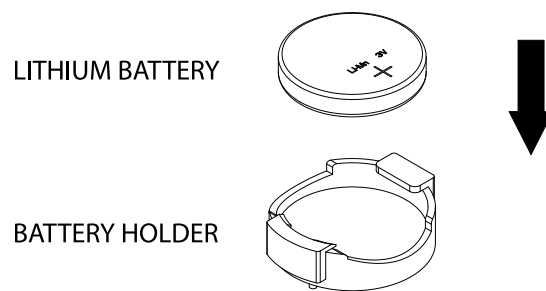

**Figure 3-1. Installing the Onboard Battery**

# Chapter 4

## UEFI BIOS

### 4.1 Introduction

This chapter describes the AMIBIOS™ setup utility for the H12DGO-6 motherboard. The BIOS is stored on a chip and can be easily upgraded using a flash program.

**Note:** Due to periodic changes to the BIOS, some settings may have been added or deleted and might not yet be recorded in this manual. Please refer to the Manual Download area of our website for any changes to the BIOS that may not be reflected in this manual.

#### Starting the Setup Utility

To enter the BIOS setup utility, press the <Delete> key while the system is booting-up. (In most cases, the <Delete> key is used to invoke the BIOS setup screen. There are a few cases when other keys are used, such as <F1>, <F2>, etc.) Each main BIOS menu option is described in this manual.

The Main BIOS screen has two main frames. The left frame displays all the options that can be configured. "Grayed-out" options cannot be configured. The right frame displays the key legend. Above the key legend is an area reserved for a text message. When an option is selected in the left frame, it is highlighted in white. Often a text message will accompany it. (Note that BIOS has default text messages built in. We retain the option to include, omit, or change any of these text messages.) Settings printed in **Bold** are the default values.

A "►" indicates a submenu. Highlighting such an item and pressing the <Enter> key will open the list of settings within that submenu.

The BIOS setup utility uses a key-based navigation system called hot keys. Most of these hot keys (<F1>, <F2>, <F3>, <F4>, <Enter>, <ESC>, <Arrow> keys, etc.) can be used at any time during the setup navigation process.

## 4.2 Main Setup

When you first enter the AMI BIOS setup utility, you will see the Main setup screen. You can always return to the Main setup screen by selecting the Main tab on the top of the screen. The Main BIOS setup screen is shown below.

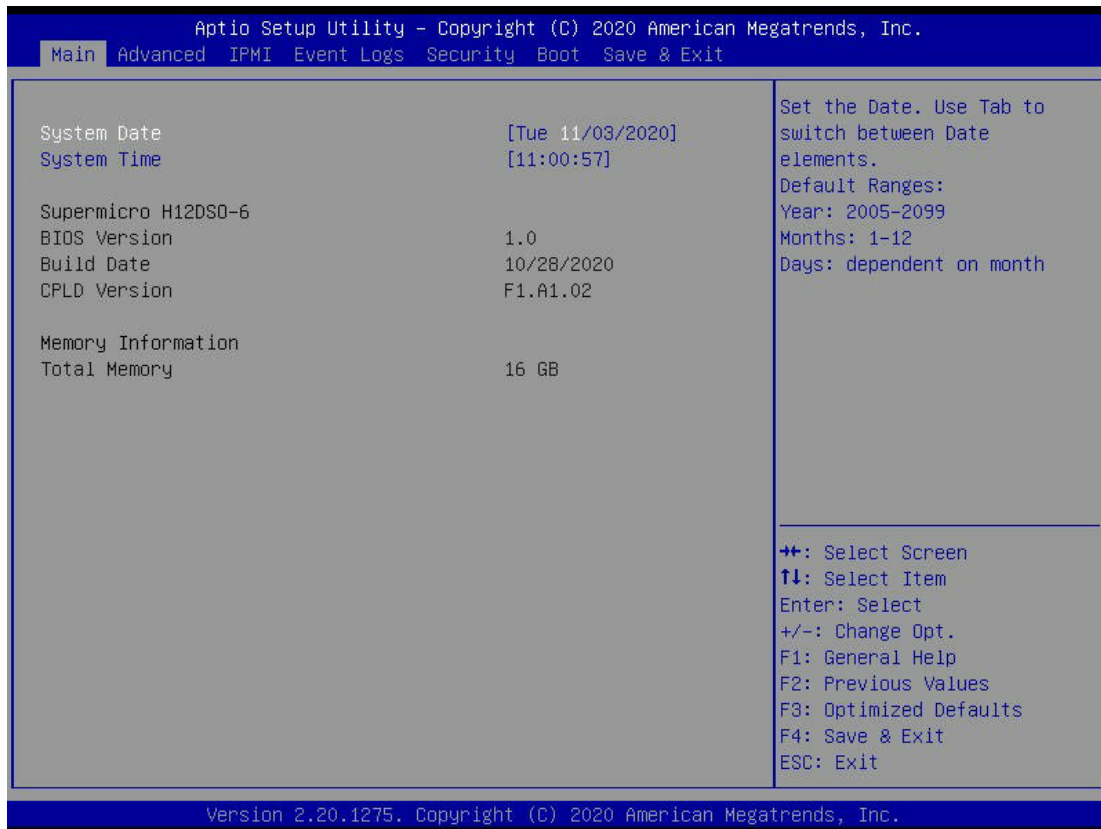

### System Date/System Time

Use this item to change the system date and time. Highlight *System Date* or *System Time* using the arrow keys. Enter new values using the keyboard. Press the <Tab> key or the arrow keys to move between fields. The date must be entered in Day MM/DD/YYYY format. The time is entered in HH:MM:SS format.

**Note:** The time is in the 24-hour format. For example, 5:30 P.M. appears as 17:30:00. The date's default value is the BIOS build date after the RTC (Real Time Clock) reset.

### Supermicro H12DGO-6

#### BIOS Version

This feature displays the version of the BIOS ROM used in the system.

**Build Date**

This feature displays the date when the version of the BIOS ROM used in the system was built.

**CPLD Version**

This feature displays the version of the CPLD (Complex-Programmable Logical Device) used in the system.

**Memory Information**

**Total Memory**

This feature displays the total size of memory available in the system.

## 4.3 Advanced

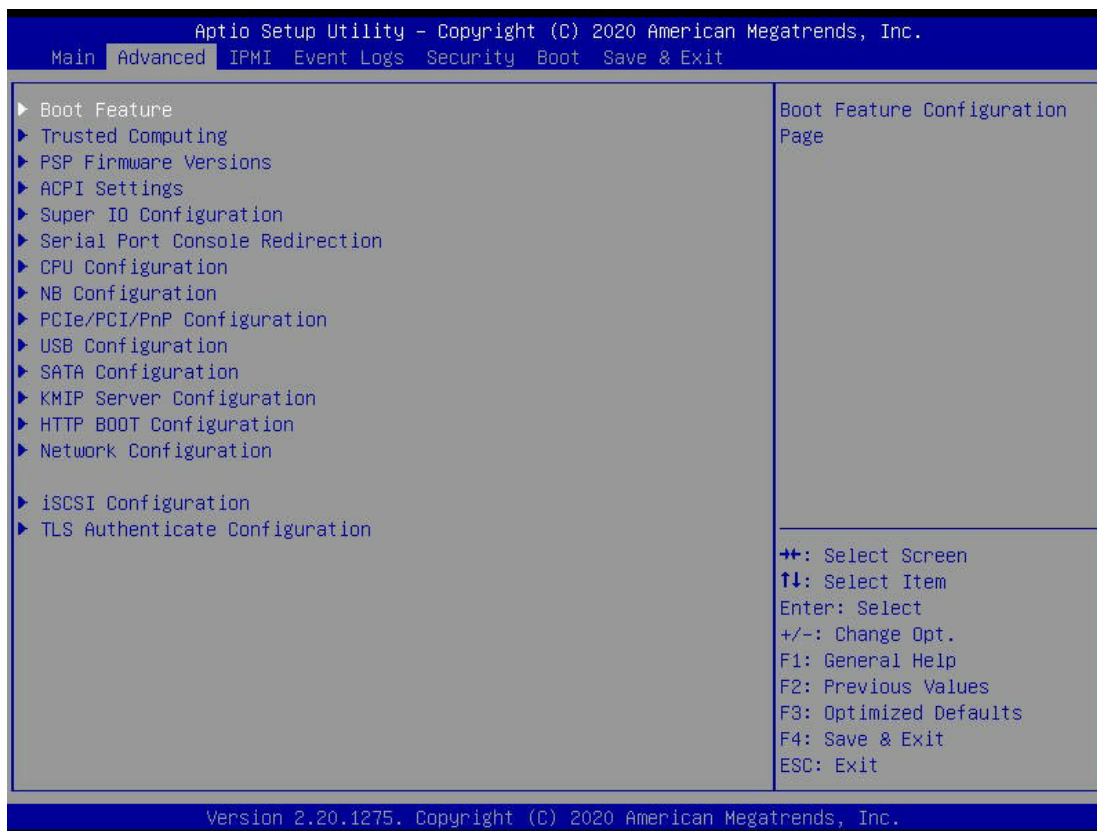

**Warning:** Take caution when changing the Advanced settings. An incorrect value, a very high DRAM frequency, or an incorrect DRAM timing setting may make the system unstable. When this occurs, revert to the default to the manufacture default settings.

### ▶ Boot Feature

#### Quiet Boot

Use this feature to select the screen display between the POST messages and the OEM logo upon bootup. Select Disabled to display the POST messages. Select Enabled to display the OEM logo instead of the normal POST messages. The options are Disabled and **Enabled**.

#### Option ROM Messages

Use this feature to set the display mode for the Option ROM. Select Keep Current to display the current AddOn ROM setting. Select Force BIOS to use the Option ROM display set by the system BIOS. The options are **Force BIOS** and Keep Current.

**Bootup NumLock State**

Use this feature to set the Power on state for the <Numlock> key. The options are **On** and Off.

**Wait For "F1" If Error**

Use this feature to force the system to wait until the 'F1' key is pressed if an error occurs. The options are Disabled and **Enabled**.

**INT19 (Interrupt 19) Trap Response**

Interrupt 19 is the software interrupt that handles the boot disk function. When this item is set to Immediate, the ROM BIOS of the host adaptors will "capture" Interrupt 19 at bootup immediately and allow the drives that are attached to these host adaptors to function as bootable disks. If this item is set to Postponed, the ROM BIOS of the host adaptors will not capture Interrupt 19 immediately and allow the drives attached to these adaptors to function as bootable devices at bootup. The options are **Immediate** and Postponed.

**Re-try Boot**

If this item is enabled, the BIOS will automatically reboot the system from a specified boot device after its initial boot failure. The options are **Disabled**, Legacy Boot, and EFI Boot.

**Power Configuration****Watch Dog Function**

If enabled, the Watch Dog Timer will allow the system to reset or generate NMI based on jumper settings when it is expired for more than 5 minutes. The options are **Disabled** and Enabled.

**Restore on AC Power Loss**

Use this feature to set the power state after a power outage. Select Stay-Off for the system power to remain off after a power loss. Select Power-On for the system power to be turned on after a power loss. Select Last State to allow the system to resume its last power state before a power loss. The options are Stay Off, Power On, and **Last State**.

**Power Button Function**

This feature controls how the system shuts down when the power button is pressed. Select 4 Seconds Override for the user to power off the system after pressing and holding the power button for 4 seconds or longer. Select Instant Off to instantly power off the system as soon as the user presses the power button. The options are **Instant Off** and 4 Seconds Override.

## ► Trusted Computing

### Configuration

#### Security Device Support

If this feature and the TPM jumper on the motherboard are both set to Enabled, onboard security devices will be enabled for TPM (Trusted Platform Module) support to enhance data integrity and network security. Please reboot the system for a change on this setting to take effect. The options are Disabled and **Enabled**.

## ► PSP Firmware Versions

This section displays the Platform Security Processor (PSP) firmware versions.

#### PSP Directory Level 1 (Fixed)

- PSP Recovery BL Ver
- SMU FW Version
- ABL Version

#### PSP Directory Level 2 (Updateable)

- PSP Bootloader Version
- SMU FW Version
- ABL Version

## ► ACPI Settings

#### PCI AER Support

The options are **Disabled** and Enabled.

#### High Precision Event Timer

The High Precision Event Timer (HPET) can produce periodic interrupts and is used to synchronize multimedia streams, providing smooth playback and reducing the need to use other timestamp calculations. The options are Disabled and **Enabled**.

#### NUMA Node Per Socket

This feature specifies the number of desired Non-Uniform Memory Access (NUMA) nodes per socket. Setting this to zero will attempt to interleave the two sockets together. The options are NPS0, NPS1, NPS2, NPS4 and **Auto**.

## ACPI SRAT L3 Cache As NUMA Domain

Use this setting to enable/disable ACPI SRAT L3 Cache As NUMA Domain. The options are Disabled, Enabled and **Auto**.

## ► Super IO Configuration

The following Super IO information will display:

Super IO Chip           AST2600

### ► Serial Port 1 Configuration

#### Serial Port

Select Enabled to enable the selected onboard serial port. The options are Disabled and **Enabled**.

#### Device Settings

This item displays the status of a serial part specified by the user.

#### Change Settings

This feature specifies the base I/O port address and the Interrupt Request address of a serial port specified by the user. Select Auto to allow the BIOS to automatically assign the base I/O and IRQ address. The options are **Auto**, IO=3F8h; IRQ=4, IO=3F8h; IRQ=3, 4, 5, 6, 7, 9, 10, 11, 12, IO=2F8h; IRQ=3, 4, 5, 6, 7, 9, 10, 11, 12, IO=3E8h; IRQ=3, 4, 5, 6, 7, 9, 10, 11, 12, and IO=2E8h; IRQ=3, 4, 5, 6, 7, 9, 10, 11, 12.

### ► SOL Configuraiton

#### Serial Port

Select Enabled to enable the selected onboard serial port. The options are Disabled and **Enabled**.

#### Device Settings

This item displays the status of a serial part specified by the user.

#### Change SOL Settings

This feature specifies the base I/O port address and the Interrupt Request address of a serial port specified by the user. Select Auto to allow the BIOS to automatically assign the base I/O and IRQ address. The options are **Auto**, IO=2F8h; IRQ=3, IO=3F8h; IRQ=3, 4, 5, 6, 7, 9, 10, 11, 12, IO=2F8h; IRQ=3, 4, 5, 6, 7, 9, 10, 11, 12, IO=3E8h; IRQ=3, 4, 5, 6, 7, 9, 10, 11, 12, and IO=2E8h; IRQ=3, 4, 5, 6, 7, 9, 10, 11, 12.

### Serial Port 2 Attribute

The options are **SOL** and COM.

## ► Serial Port Console Redirection

### COM1

#### Console Redirection

Select Enabled to enable console redirection support for a serial port specified by the user. The options are **Disabled** and Enabled.

*\*If the item above set to Enabled, the following items will become available for user's configuration:*

### ► Console Redirection Settings

#### Terminal Type

This feature allows the user to select the target terminal emulation type for Console Redirection. Select VT100 to use the ASCII Character set. Select VT100+ to add color and function key support. Select ANSI to use the Extended ASCII Character Set. Select VT-UTF8 to use UTF8 encoding to map Unicode characters into one or more bytes. The options are VT100, **VT100+**, VT-UTF8, and ANSI.

#### Bits per second

Use this feature to set the transmission speed for a serial port used in Console Redirection. Make sure that the same speed is used in the host computer and the client computer. A lower transmission speed may be required for long and busy lines. The options are 9600, 19200, 38400, 57600 and **115200** (bits per second).

#### Data Bits

Use this feature to set the data transmission size for Console Redirection. The options are 7 and **8**.

#### Parity

A parity bit can be sent along with regular data bits to detect data transmission errors. Select Even if the parity bit is set to 0, and the number of 1's in data bits is even. Select Odd if the parity bit is set to 0, and the number of 1's in data bits is odd. Select None if you do not want to send a parity bit with your data bits in transmission. Select Mark to add a mark as a parity bit to be sent along with the data bits. Select Space to add a Space as a parity bit to be sent with your data bits. The options are **None**, Even, Odd, Mark, and Space.

**Stop Bits**

A stop bit indicates the end of a serial data packet. Select 1 Stop Bit for standard serial data communication. Select 2 Stop Bits if slower devices are used. The options are **1** and **2**.

**Flow Control**

Use this feature to set the flow control for Console Redirection to prevent data loss caused by buffer overflow. Send a "Stop" signal to stop sending data when the receiving buffer is full. Send a "Start" signal to start sending data when the receiving buffer is empty. The options are **None** and Hardware RTS/CTS.

**VT-UTF8 Combo Key Support**

Select Enabled to enable VT-UTF8 Combination Key support for ANSI/VT100 terminals. The options are Disabled and **Enabled**.

**Recorder Mode**

Select Enabled to capture the data displayed on a terminal and send it as text messages to a remote server. The options are **Disabled** and Enabled.

**Resolution 100x31**

Select Enabled for extended-terminal resolution support. The options are Disabled and **Enabled**.

**Legacy OS Redirection Resolution**

For Legacy OS systems, use this setting to specify the number of Rows and Columns supported for redirection. Options include 80x24 and **80x25**.

**Putty KeyPad**

This feature selects the settings for Function Keys and KeyPad used for Putty, which is a terminal emulator designed for the Windows OS. The options are **VT100**, LINUX, XTERMR6, SC0, ESCN, and VT400.

**Redirection After BIOS POST**

For this setting, when the Bootloader is selected, then the Legacy Console Redirection is disabled before booting to the legacy OS. If you select Always Enable, then the Legacy Console Redirection is enabled for legacy OS systems. Default option for this system is **Always Enable**. The options are **Always Enable** and BootLoader.

## SOL

### Console Redirection

Select Enabled to enable SOL console redirection support for a serial port specified by the user. The options are Disabled and **Enabled**.

***\*If the item above set to Enabled, the following items will become available for user's configuration:***

### ► Console Redirection Settings

#### Terminal Type

This feature allows the user to select the target terminal emulation type for Console Redirection. Select VT100 to use the ASCII Character set. Select VT100+ to add color and function key support. Select ANSI to use the Extended ASCII Character Set. Select VT-UTF8 to use UTF8 encoding to map Unicode characters into one or more bytes. The options are VT100, **VT100+**, VT-UTF8, and ANSI.

#### Bits per second

Use this feature to set the transmission speed for a serial port used in Console Redirection. Make sure that the same speed is used in the host computer and the client computer. A lower transmission speed may be required for long and busy lines. The options are 9600, 19200, 38400, 57600 and **115200** (bits per second).

#### Data Bits

Use this feature to set the data transmission size for Console Redirection. The options are 7 and **8**.

#### Parity

A parity bit can be sent along with regular data bits to detect data transmission errors. Select Even if the parity bit is set to 0, and the number of 1's in data bits is even. Select Odd if the parity bit is set to 0, and the number of 1's in data bits is odd. Select None if you do not want to send a parity bit with your data bits in transmission. Select Mark to add a mark as a parity bit to be sent along with the data bits. Select Space to add a Space as a parity bit to be sent with your data bits. The options are **None**, Even, Odd, Mark, and Space.

#### Stop Bits

A stop bit indicates the end of a serial data packet. Select 1 Stop Bit for standard serial data communication. Select 2 Stop Bits if slower devices are used. The options are **1** and **2**.

#### Flow Control

Use this feature to set the flow control for Console Redirection to prevent data loss caused by buffer overflow. Send a "Stop" signal to stop sending data when the receiving buffer

is full. Send a "Start" signal to start sending data when the receiving buffer is empty. The options are **None** and Hardware RTS/CTS.

#### **VT-UTF8 Combo Key Support**

Select Enabled to enable VT-UTF8 Combination Key support for ANSI/VT100 terminals. The options are Disabled and **Enabled**.

#### **Recorder Mode**

Select Enabled to capture the data displayed on a terminal and send it as text messages to a remote server. The options are **Disabled** and Enabled.

#### **Resolution 100x31**

Select Enabled for extended-terminal resolution support. The options are Disabled and **Enabled**.

#### **Legacy OS Redirection Resolution**

For Legacy OS systems, use this setting to specify the number of Rows and Columns supported for redirection. Options include 80x24 and **80x25**.

#### **Putty KeyPad**

This feature selects the settings for Function Keys and KeyPad used for Putty, which is a terminal emulator designed for the Windows OS. The options are **VT100**, LINUX, XTERMR6, SC0, ESCN, and VT400.

#### **Redirection After BIOS POST**

For this setting, when the Bootloader is selected, then the Legacy Console Redirection is disabled before booting to the legacy OS. If you select Always Enable, then the Legacy Console Redirection is enabled for legacy OS systems. Default option for this system is **Always Enable**. The options are **Always Enable** and BootLoader.

## ► Legacy Console Redirection Settings

### Legacy Serial Redirection Port

For this setting, select a COM port to display redirection of Legacy OS and Legacy OPRM messages. Options include **COM1** and SOL.

### Serial Port for Out-of-Band Management/Windows Emergency Management Services (EMS)

#### Console Redirection

Select Enabled to enable EMS console redirection support for a serial port specified by the user. The options are **Enabled** and Disabled.

*\*If the item above set to Enabled, the following items will become available for user's configuration:*

## ► Console Redirection Settings

### Out-of-Band Mgmt Port

The feature selects a serial port in a client server to be used by the Microsoft Windows Emergency Management Services (EMS) to communicate with a remote host server. The options are **COM1** and SOL.

### Terminal Type

Use this feature to select the target terminal emulation type for Console Redirection. Select VT100 to use the ASCII character set. Select VT100+ to add color and function key support. Select ANSI to use the extended ASCII character set. Select VT-UTF8 to use UTF8 encoding to map Unicode characters into one or more bytes. The options are VT100, VT100+, **VT-UTF8**, and ANSI.

### Bits per second

This item sets the transmission speed for a serial port used in Console Redirection. Make sure that the same speed is used in the host computer and the client computer. A lower transmission speed may be required for long and busy lines. The options are 9600, 19200, 57600, and **115200** (bits per second).

### Flow Control

Use this item to set the flow control for Console Redirection to prevent data loss caused by buffer overflow. Send a "Stop" signal to stop sending data when the receiving buffer

is full. Send a "Start" signal to start sending data when the receiving buffer is empty. The options are **None**, Hardware RTS/CTS, and Software Xon/Xoff.

#### **Data Bits**

Use this feature to set the data transmission size for Console Redirection. The options are 7 and 8.

#### **Parity**

A parity bit can be sent along with regular data bits to detect data transmission errors. Select Even if the parity bit is set to 0, and the number of 1's in data bits is even. Select Odd if the parity bit is set to 0, and the number of 1's in data bits is odd. Select None if you do not want to send a parity bit with your data bits in transmission. Select Mark to add a mark as a parity bit to be sent along with the data bits. Select Space to add a Space as a parity bit to be sent with your data bits. The options are **None**, Even, Odd, Mark, and Space.

#### **Stop Bits**

A stop bit indicates the end of a serial data packet. Select 1 Stop Bit for standard serial data communication. Select 2 Stop Bits if slower devices are used. The options are 1 and 2.

## **► CPU Configuration**

### **SMT Control**

Use this setting to specify Simultaneous Multithreading. Options include Off for 1T single thread and **Auto** for 2T two-thread if your system is capable of it.

### **Core Performance Boost**

This setting is used to configure for Core Performance Boost. Options include Disabled and **Auto**.

### **Global C-state Control**

This setting is used to configure for Global C-state Control. Options include Disabled, Enabled and **Auto**.

### **Local APIC Mode**

Use this setting to adjust local APIC mode. Options include xAPIC, x2APIC and **Auto**.

### **CCD Control**

Use this setting to disable CCDs in the CPU. Options include **Auto**, 2 CCDs, 3 CCDs, 4 CCDs and 6 CCDs.

### **Core Control**

This sets the number of cores to be used by your system. Once this option has been used to remove any cores, a power cycle is required in order for the future selections to take effect. Options include **Auto**, TWO (1+1), FOUR (2 + 2), and SIX (3 + 3). If unsure, leave this to Auto.

### **L1 Stream HW Prefetcher/L2 Stream HW Prefetcher**

This setting is used to enable or disable the L1/L2 Stream Hardware Prefetcher. The options are Disabled, Enabled and **Auto**.

### **SVM Mode**

This setting **Enables** or Disables CPU Virtualization.

### **SMEE**

This setting Enables or **Disables** secure memory encryption.

## **► CPU1/CPU2 Information**

These sections are for informational purposes. They will display some details about the detected CPUs on the motherboard, such as:

- CPU Version
- Number of Cores Running
- Processor Family
- Processor Model
- Microcode Patch Level
- L1 Instruction Cache (Size/Method)
- L1 Data Cache (Size/Method)
- L2 Data Cache (Size/Method)
- L3 Cache per Socket (Size/Method)

## **► NB Configuration**

### **Determinism Control**

Use this setting to configure the Determinism Control. Options include Manual and **Auto**.

**cTDP Control**

Use this setting to configure the cTDP Control. Options include Manual and **Auto**.

**IOMMU**

Use this setting to enable/disable IOMMU. Options include **Disabled**, Enabled, and Auto.

**ACS Enable**

Use this setting to enable/disable ACS. Options include Enabled, Disabled and **Auto**.

**Package Power Limit Control**

Use this setting for Package Power Limit Control. Options include Manual and **Auto**.

**APBDIS**

Use this setting to set APBDIS. Options include 0, 1 and **Auto**.

**DF Cstates**

Use this setting to enable/disable DF Cstates. Options include Disabled, Enabled, and **Auto**.

**Preferred IO**

Use this setting for Preferred IO. Options include Manual and **Auto**.

**► Memory Configuration****Memory Clock**

This setting allows you to select different memory clock speed. The options include **Auto** and speed settings from 2666MHz, 2933MHz to 3200MHz.

**Memory Interleaving**

This setting controls fabric level memory interleaving. Note that the channel, die and socket have requirements on memory populations and it will be ignored if the memory doesn't support the selected option. The options are Disabled and **Auto**.

**Memory Interleaving Size**

This setting controls the memory interleaving size. This determines the starting address of the interleave (bit 8, 9, 10 or 11). The options are 256 Bytes, 512 Bytes, 1 KB, 2 KB and **Auto**.

**Chipselect Interleaving**

This setting controls interleave memory blocks across the DRAM chip for node 0. The options are Disabled and **Auto**.

**BankGroupSwap**

This setting controls the Bank Group Swap. The options are Enabled, Disabled and **Auto**.

### **DRAM Scrub Time**

This setting provides a value that is the number of hours to scrub memory. The options are Disabled, 1 hour, 4 hours, 8 hours, 16 hours, 24 hours, 48 hours and **Auto**.

### **► CPU1 Memory Configuration**

These sections are for informational purposes. They will display some details about the detected memory according to each CPU on the motherboard, such as:

- Detected Size (per slot, in MB)
- Current Speed (MT/s)

### **► CPU2 Memory Configuration**

These sections are for informational purposes. They will display some details about the detected memory according to each CPU on the motherboard, such as:

- Detected Size (per slot, in MB)
- Current Speed (MT/s)

---

## ► PCIe/PCI/PnP Configuration

This menu provides PCIe/PCI/PnP configuration settings and information.

### PCI Bus Driver Version

#### PCI Devices Common Settings:

##### Above 4G Decoding

This setting Disables or **Enables** 64-bit capable devices ability to be decoded in above 4G address space (only if the system supports 64-bit PCI decoding).

##### SR-IOV Support

If the system has SR-IOV capable PCIe devices, this setting will Disables or **Enable** the Single Root IO Virtualization Support for the system.

##### BME DMA Mitigation

Re-enable Bus Master Attribute disabled during Pci enumeration for PCI Bridges after SMM Locked. The options are **Disabled** and Enabled.

##### PCIe ARI Support

Use this setting to Disable, Enable or **Auto** control the Alternative Routing-ID Interpretation.

##### PCIe Spread Spectrum

Use this setting to **Disable** or Enable PCIe Spread Spectrum for your system.

##### Relaxed Ordering

Select Enabled to allow certain PCIe transactions to violate the strict ordering rules of PCIe so that a transaction can be completed before other transactions that have already been queued in order to enhance PCIe performance. The options are **Disabled** and Enabled.

##### VGA Priority

Use this setting to select between onboard or offboard VGA support. The options are **Onboard** and Offboard.

##### NVMe Firmware Source

Use this setting to select between the AMI Native firmware support or the device vendor-defined firmware support. The options are **Vendor Defined Firmware** and AMI Native Support.

##### SLOT1 PCIe 4.0 x16 OPROM

This setting enables or disables the listed PCI/PCIX/PCIe Slot OPROM option. The options include Disabled, **Legacy** and EFI.

#### **SLOT2 PCIe 4.0 x16 OPROM**

This setting enables or disables the listed PCI/PCIX/PCIe Slot OPROM option. The options include Disabled, **Legacy** and EFI.

#### **SLOT3 PCIe 4.0 x16 OPROM**

This setting enables or disables the listed PCI/PCIX/PCIe Slot OPROM option. The options include Disabled, **Legacy** and EFI.

#### **SLOT4 PCIe 4.0 x16 OPROM**

This setting enables or disables the listed PCI/PCIX/PCIe Slot OPROM option. The options include Disabled, **Legacy** and EFI.

#### **SLOT5 PCIe 4.0 x16 OPROM**

This setting enables or disables the listed PCI/PCIX/PCIe Slot OPROM option. The options include Disabled, **Legacy** and EFI.

#### **Onboard LAN1 Option ROM**

Use this setting to select which firmware function is to be loaded for onboard LAN1 on the system. Options include Disabled, **PXE**, iSCSI and EFI.

#### **Onboard LAN2 Option ROM**

Use this setting to select which firmware function is to be loaded for onboard LAN1 on the system. Options include **Disabled** and PXE.

#### **Onboard NVMe1 Option ROM**

Select EFI to allow the user to boot the computer using an EFI (Extensible Firmware Interface) device installed on the NVME connector specified by the user. Select Legacy to allow the user to boot the computer using a legacy device installed on the NVME connector specified by the user. The options include Disabled, Legacy and **EFI**.

#### **Onboard NVMe2 Option ROM**

Select EFI to allow the user to boot the computer using an EFI (Extensible Firmware Interface) device installed on the NVME connector specified by the user. Select Legacy to allow the user to boot the computer using a legacy device installed on the NVME connector specified by the user. The options include Disabled, Legacy and **EFI**.

#### **Onboard NVMe3 Option ROM**

Select EFI to allow the user to boot the computer using an EFI (Extensible Firmware Interface) device installed on the NVME connector specified by the user. Select Legacy to allow the user to boot the computer using a legacy device installed on the NVME connector specified by the user. The options include Disabled, Legacy and **EFI**.

**Onboard NVMe4 Option ROM**

Select EFI to allow the user to boot the computer using an EFI (Extensible Firmware Interface) device installed on the NVME connector specified by the user. Select Legacy to allow the user to boot the computer using a legacy device installed on the NVME connector specified by the user. The options include Disabled, Legacy and **EFI**.

**Onboard NVMe5 Option ROM**

Select EFI to allow the user to boot the computer using an EFI (Extensible Firmware Interface) device installed on the NVME connector specified by the user. Select Legacy to allow the user to boot the computer using a legacy device installed on the NVME connector specified by the user. The options include Disabled, Legacy and **EFI**.

**Onboard NVMe6 Option ROM**

Select EFI to allow the user to boot the computer using an EFI (Extensible Firmware Interface) device installed on the NVME connector specified by the user. Select Legacy to allow the user to boot the computer using a legacy device installed on the NVME connector specified by the user. The options include Disabled, Legacy and **EFI**.

**Onboard Video Option ROM**

Use this setting to select which firmware function is to be loaded for onboard video option ROM on the system. The options include Disabled, **Legacy** and EFI.

**► Network Stack Configuration****Network Stack**

This setting allows you to enable or disable the UEFI Network Stack. The options are Disabled and **Enabled**.

**IPv4 PXE Support**

This setting allows you to enable or disable IPv4 PXE boot support. If disabled, IPv4 PXE boot support will not be available. The options are Disabled and **Enabled**.

**IPv4 HTTP Support**

This setting allows you to enable or disable IPv4 HTTP boot support. If disabled, IPv4 HTTP boot support will not be available. The options are **Disabled** and Enabled.

**IPv6 PXE Support**

This setting allows you to enable or disable IPv6 PXE boot support. If disabled, IPv6 PXE boot support will not be available. The options are Disabled and **Enabled**.

### **IPv6 HTTP Support**

This setting allows you to enable or disable IPv6 HTTP boot support. If disabled, IPv6 HTTP boot support will not be available. The options are **Disabled** and Enabled.

### **PXE boot wait time**

This setting allows you to set in a number field the wait time to press <ESC> to abort the PXE boot. The default value is **0**.

### **Media detect count**

This setting allows you set in a number field the number of times presence of media will be checked. The default value is **1**.

## **►USB Configuration**

### **USB Configuration**

#### **USB Module Version**

#### **USB Controllers**

#### **USB Devices**

#### **Legacy USB Support**

Select Enabled to support onboard legacy USB devices. Select Auto to disable legacy support if there are no legacy USB devices present. Select Disable to have all USB devices available for EFI applications only. The options include **Enabled**, Disabled and Auto.

#### **XHCI Hand-off**

This is a work-around solution for operating systems that do not support XHCI (Extensible Host Controller Interface) hand-off. The XHCI ownership change should be claimed by the XHCI driver. The options include **Enabled** and Disabled.

#### **Port 60/64 Emulation**

Select Enabled for I/O port 60h/64h emulation support, which in turn, will provide complete legacy USB keyboard support for the operating systems that do not support legacy USB devices. The options include Disabled and **Enabled**.

## **►SATA Configuration**

This section displays the detected SATA devices installed on the system.

#### **SATA Enable**

This setting enables or disables the on chip SATA controller. The options are Disabled, Enabled, and **Auto**.

## **SATA Hotplug**

This setting enables or disables the on chip SATA hot plug feature. The options are Disabled, and **Enabled**.

### **▶SATA Information**

This section displays information on the detected SATA devices:

- SATA0 ~ SATA3

## **▶KMIP Server Configuration**

**KMIP Server IP address**

**KMIP TCP Port number**

**TimeZone**

**Clinet UserName**

**Client Password**

### **▶CA Certificate**

The options include Update, Delete, and Export.

### **▶Client Certificate**

The options include Update, Delete, and Export.

### **▶Client Private Key**

The options include Update, Delete, and Export.

## **▶HTTP Boot Configuration**

**HTTP Boot One Time**

The default setting is Disabled.

**Input the description**

**Boot URI**

A new Boot Option will be created according to this Boot URI. It is only supported on Dual or EFI Boot Mode.

## ► Network Configuration

### MAC: B03FAF2B6059F - IPv4 Network Configuration

#### Configured

The options include **Disabled** and **Enabled**.

***\*If the item above is set to Enabled, the following item will become available for configuration:***

#### Enable DHCP

This feature allows the user to select the source of the IP address for this computer. If **Disabled** is selected, you will need to know the local IP address of this computer and enter it to the system manually in the field. If **Enabled** is selected, the system will search for a DHCP (Dynamic Host Configuration Protocol) server in the network that it is attached to and request the next available IP address for this computer. The options include **Disabled** and **Enabled**.

***\*If the item above is set to Disabled, the following items will become available for configuration:***

#### Local IP Address

This item sets and displays the Local IP address for this computer. This should be in decimal and in dotted quad form.

#### Local NetMask

This item sets the sub-network that this computer belongs to. The value of each three-digit number separated by dots should not exceed 255.

#### Local Gateway

This item sets the Gateway IP address for this computer. This should be in decimal and in dotted quad form (i.e., 172.31.0.1).

#### Local DNS Servers

This item sets the address for the local DNS servers for this computer. This should be in decimal and in dotted quad form (i.e., 172.31.0.1).

#### Save Changes and Exit

Use this item to save the changes above and exit.

---

---

### ▶ VLAN Configuration (MAC: ACIF6BBB6FB0)

Use this item to save the changes above and exit.

### ▶ VLAN Configuration (MAC: ACIF6BBB6FB1)

#### ▶ Enter Configuration Menu

##### Create new VLAN

###### VLAN ID

This option is an input field used to enter a unique numeric VLAN ID. The valid range is from 0~4096.

###### Priority

This option is an input field used to enter a unique numeric VLAN 802.1Q priority. The valid range is from 0~7.

###### Add VLAN

Click this option to create the new VLAN.

###### Configuration VLAN List

###### VLAN ID: 0, Priority:0

The options include **Disabled** and Enabled.

##### Remove VLAN

Click this option to remove an existing VLAN.

### ▶ MAC:AC1F6BBB6FB1-IPv4 Network Configuration

#### Configured

The options include **Disabled** and Enabled.

***\*If the item above is set to Enabled, the following item will become available for configuration:***

#### Enable DHCP

This feature allows the user to select the source of the IP address for this computer. If Disabled is selected, you will need to know the local IP address of this computer and enter it to the system manually in the field. If Enabled is selected, the system will search for a DHCP (Dynamic Host Configuration Protocol) server in the network that it is attached to and request the next available IP address for this computer. The options include **Disabled** and Enabled.

*\*If the item above is set to Disabled, the following items will become available for configuration:*

**Local IP Address**

This item sets and displays the Local IP address for this computer. This should be in decimal and in dotted quad form.

**Local NetMask**

This item sets the sub-network that this computer belongs to. The value of each three-digit number separated by dots should not exceed 255.

**Local Gateway**

This item sets the Gateway IP address for this computer. This should be in decimal and in dotted quad form (i.e., 172.31.0.1).

**Local DNS Servers**

This item sets the address for the local DNS servers for this computer. This should be in decimal and in dotted quad form (i.e., 172.31.0.1).

**Save Changes and Exit**

Use this item to save the changes above and exit.

**▶MAC:AC1F6BBB6FB1-IPv6 Network Configuration**

**▶Enter Configuration Menu**

**Interface Name**

**Interface Type**

**MAC address**

**Host addresses**

**Route Table**

**Gateway addresses**

**DNS addresses**

**Interface ID**

**DAD Transmit Count**

**Policy**

Options include **automatic** and manual.

**Save Changes and Exit**

Use this item to save the changes above and exit.

## 4.4 IPMI

Use this feature to configure Event Log settings.

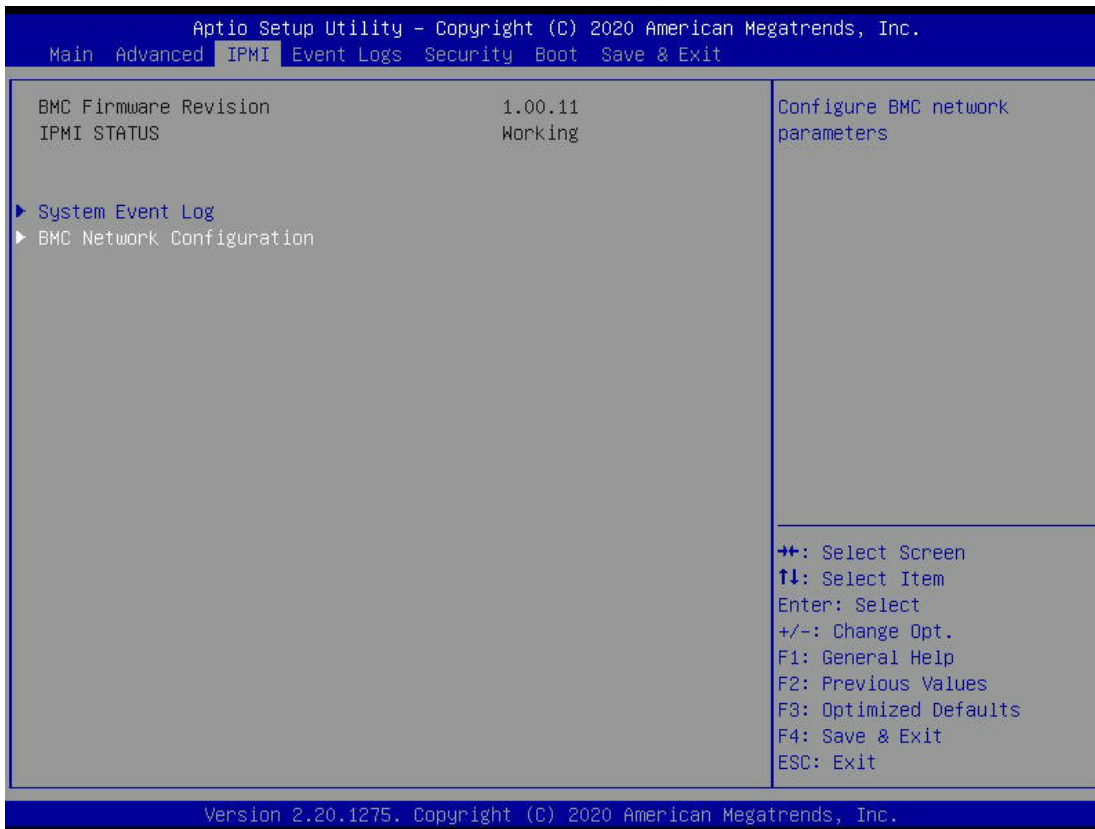

### ► System Event Log

#### SEL Components

Select Enabled for all system event logging at bootup. The options include Disabled and Enabled.

#### Erasing Settings

##### Erase SEL

Select Yes, On next reset to erase all system event logs upon next system reboot. Select Yes, On every reset to erase all system event logs upon each system reboot. Select No to keep all system event logs after each system reboot. The options include **No**, Yes, On next reset, and Yes, On every reset.

### **When SEL is Full**

This feature allows the user to decide what the BIOS should do when the system event log is full. Select Erase Immediately to erase all events in the log when the system event log is full. The options include **Do Nothing** and Erase Immediately.

## **► BMC Network Configuration**

### **Update IPMI LAN Configuration**

Select Yes for the BIOS to implement all IP/MAC address changes at the next system boot. The options include **No** and Yes.

***\*If the item above set to Yes, the following item will become available for user's configuration:***

### **Configuration Address Source**

This feature allows the user to select the source of the IP address for this computer. If Static is selected, you will need to know the IP address of this computer and enter it to the system manually in the field. If DHCP is selected, the BIOS will search for a DHCP (Dynamic Host Configuration Protocol) server in the network that is attached to and request the next available IP address for this computer. The options include Static and **DHCP**.

### **VLAN**

This item configures the virtual LAN settings. The options include **Disabled** and Enabled.

### **IPv6 Support**

Use this feature to enable IPv6 support. The options include Enabled and **Disabled**.

## 4.5 Event Logs

Use this feature to configure Event Log settings.

**Note:** After you've made a change on a setting below, please be sure to reboot the system for the change to take effect.

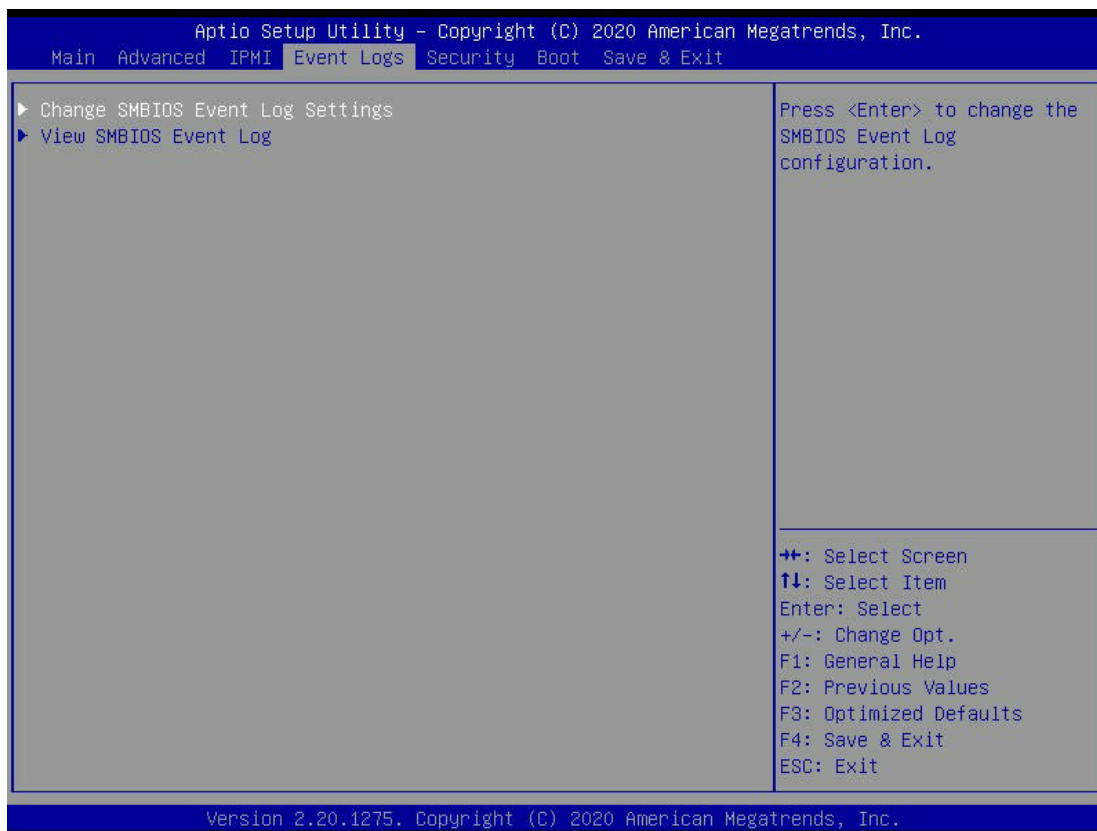

### ▶ Change SMBIOS Event Log Settings

#### Enabling/Disabling Options

#### SMBIOS Event Log

Select Enabled to enable SMBIOS (System Management BIOS) Event Logging during system boot. The options are Disabled and **Enabled**.

## Erasing Settings

### Erase Event Log

Select No to keep the event log without erasing it upon next system bootup. Select Yes, Next Reset to erase the event log upon next system reboot. The options are **No**, Yes, Next reset, and Yes, Every eset.

### When Log is Full

Select Erase Immediately to immediately erase all errors in the SMBIOS event log when the event log is full. Select Do Nothing for the system to do nothing when the SMBIOS event log is full. The options are **Do Nothing** and Erase Immediately.

## SMBIOS Event Log Standard Settings

### Log System Boot Event

Select Enabled to log system boot events. The options are Enabled and **Disabled**.

### MECI (Multiple Event Count Increment)

Enter the increment value for the multiple event counter. Enter a number between 1 to 255. The default setting is **1**.

### METW (Multiple Event Count Time Window)

This feature is used to determine how long (in minutes) should the multiple event counter wait before generating a new event log. Enter a number between 0 to 99. The default setting is **60**.

## 4.6 Security Settings

This menu allows the user to configure the following security settings for the system.

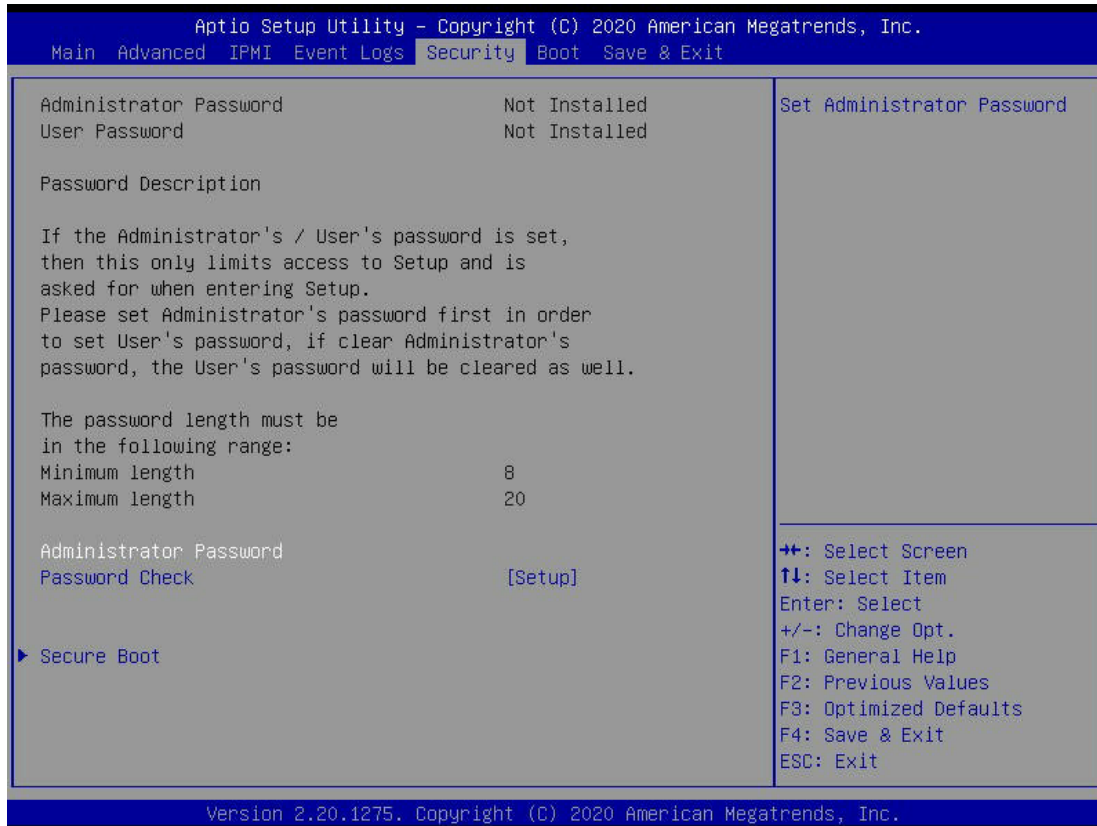

### Administrator Password

Use this feature to set the administrator password which is required to enter the BIOS setup utility. The length of the password should be from 3 characters to 20 characters long.

### Password Check

Select Setup for the system to check for a password at Setup. Select Always for the system to check for a password at system boot and upon entering the BIOS Setup utility. The options are **Setup** and Always.

### ▶ Secure Boot

When you select this submenu and press the <Enter> key, the following items will display:

- System Mode
- Vendor Keys

- Sucre Boot

### **Secure Boot**

Select Enabled to use Secure Boot settings. The options are **Disabled** and Enabled.

### **Secure Boot Mode**

Use this feature to select the desired secure boot mode for the system. The options are Standard and **Custom**.

### **CMS Support**

If this feature is set to Enabled, legacy devices will be supported by the system. The options are Disabled and **Enabled**.

## **►Key Management**

### **Provision Factory Defaults**

The options are **Disabled** and Enabled.

### **►Restore Factory Keys**

Select Yes to restore manufacturer default keys used to ensure system security. The options are **Yes** and No.

### **►Reset To Setup Mode**

Select Yes to reset the system to the Setup Mode. The options are **Yes** and No.

### **►Export Secure Boot Variables**

This feature is used to copy the NVRAM content of Secure Boot variables to a storage device.

### **►Enroll Efi Image**

Select this feature and press <Enter> to specify an EFI (Extensible Firmware Interface) image for the system to use when it operates in the Secure Boot mode.

## Device Guard Ready

### ▶ Remove 'UEFI CA' from DB

Select Yes to remove UEFI CA from the database. The options are **Yes** and No.

### ▶ Restore DB defaults

Select Yes to restore database variables to the manufacturer default settings. The options are **Yes** and No.

## Secure Boot Variable/Size/Keys/Key Source

### ▶ Platform Key (PK)

This feature allows the user to enter and configure a set of values to be used as platform firmware keys for the system. The sizes, keys numbers, and key sources of the platform keys will be indicated as well. Select Update to update the platform key.

### ▶ Key Exchange Keys

This feature allows the user to enter and configure a set of values to be used as Key-Exchange-Keys for the system. The sizes, keys numbers, and key sources of the Key-Exchange-Keys will be indicated as well. Select Update to update your "Key Exchange Keys". Select Append to append your "Key Exchange Keys".

### ▶ Authorized Signatures

This feature allows the user to enter and configure a set of values to be used as Authorized Signatures for the system. These values also indicate the sizes, keys numbers, and the sources of the authorized signatures. Select Update to update your "Authorized Signatures". Select Append to append your "Authorized Signatures". The settings are **Update**, and Append.

### ▶ Forbidden Signatures

This feature allows the user to enter and configure a set of values to be used as Forbidden Signatures for the system. These values also indicate sizes, keys numbers, and key sources

of the forbidden signatures. Select Update to update your "Forbidden Signatures". Select Append to append your "Forbidden Signatures". The settings are **Update**, and Append.

### ► **Authorized TimeStamps**

This feature allows the user to set and save the timestamps for the authorized signatures which will indicate the time when these signatures are entered into the system. Select Update to update your "Authorized TimeStamps". Select Append to append your "Authorized TimeStamps". The settings are **Update**, and Append.

### ► **Os Recovery Signatures**

This feature allows the user to set and save the authorized signatures used for OS recovery. Select Update to update your "OS Recovery Signatures". Select Append to append your "OS Recovery Signatures". The settings are **Update**, and Append.

## 4.7 Boot Settings

Use this feature to configure Boot Settings:

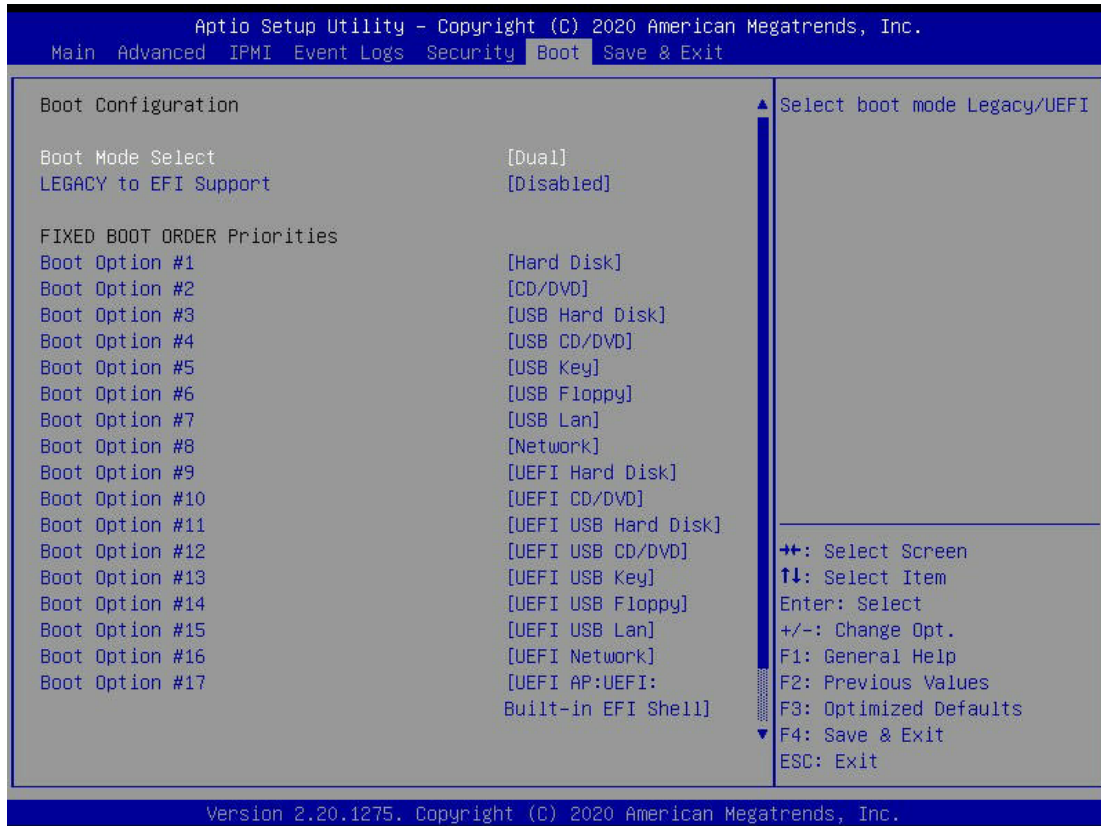

### Boot Mode Select

Use this feature to select the type of devices from which the system will boot. The options are Legacy, UEFI (Unified Extensible Firmware Interface), and **Dual**.

### LEGACY to EFI Support

Select Enabled for the system to boot from an EFI OS when the Legacy OS fails. The options are **Disabled** and Enabled.

### FIXED BOOT ORDER Priorities

This feature prioritizes the order of a bootable device from which the system will boot. Press <Enter> on each item sequentially to select devices.

When the item above -"Boot Mode Select" is set to **Dual** (default), the following items will be displayed for user's configuration:

Boot Option #1 - Boot Option #17

When the item above -"Boot Mode Select" is set to Legacy, the following items will be displayed for configuration:

- Boot Option #1 - Boot Option #8

When the item above -"Boot Mode Select" is set to UEFI, the following items will be displayed for configuration:

- Boot Option #1 - Boot Option #9

### ▶ **Delete Boot Option**

Use this feature to select a boot device to delete from the boot priority list.

#### **Delete Boot Option**

Use this feature to remove an EFI boot option from the boot priority list.

### ▶ **UEFI Application Boot Priorities**

Use this feature to specify the boot device Priority sequence from available UEFI application.

### ▶ **UEFI NETWORK Drive BBS Priorities**

Use this feature to specify the boot device priority sequence from available UEFI NETWORK drives.

### ▶ **NETWORK Drive BBS Priorities**

Use this feature to specify the boot device priority sequence from available NETWORK drives.

## 4.8 Save & Exit

Select the Save & Exit menu from the BIOS setup screen to configure the settings below.

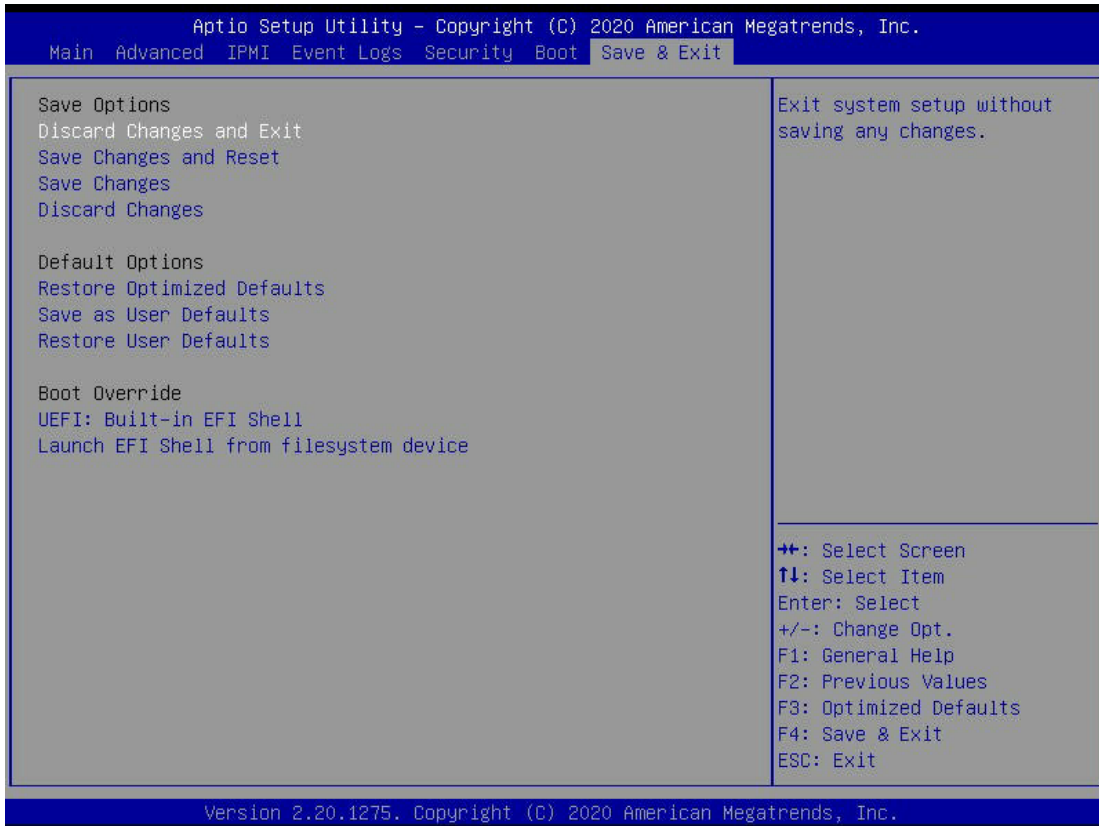

### Save Options

#### Discard Changes and Exit

Select this option to exit from the BIOS setup utility without making any permanent changes to the system configuration and reboot the computer.

#### Save Changes and Reset

When you have completed the system configuration changes, select this option to leave the BIOS setup utility and reboot the computer for the new system configuration parameters to become effective.

#### Save Changes

When you have completed the system configuration changes, select this option to save all changes made. This will not reset (reboot) the system.

**Discard Changes**

Select this option and press <Enter> to discard all the changes you've made and return to the AMI BIOS setup utility.

**Default Options****Restore Optimized Defaults**

To set this feature, select Restore Defaults from the Exit menu and press <Enter> to load manufacturer default settings which are intended for maximum system performance but not for maximum stability.

**Save as User Defaults**

To set this feature, select Save as User Defaults from the Exit menu and press <Enter>. This enables the user to save all changes to the BIOS setup for future use.

**Restore User Defaults**

To set this feature, select Restore User Defaults from the Exit menu and press <Enter>. Use this feature to retrieve user-defined default settings that were saved previously.

**Boot Override**

This feature allows the user to override the Boot priorities sequence in the Boot menu, and immediately boot the system with a device specified by the user instead of the one specified in the boot list. This is a one-time override.

**UEFI: Built-in EFI Shell****Launch EFI Shell from filesystem device**

# Appendix A

## Software

After the hardware has been installed, you can install the Operating System (OS), configure RAID settings and install the drivers.

### A.1 Microsoft Windows OS Installation

If you will be using RAID, you must configure RAID settings before installing the Windows OS and the RAID driver. Refer to the RAID Configuration User Guides posted on our website at [www.supermicro.com/support/manuals](http://www.supermicro.com/support/manuals).

Installing the OS

1. Create a method to access the MS Windows installation ISO file. That might be a DVD, perhaps using an external USB/SATA DVD drive, or a USB flash drive, or the IPMI KVM console.
2. Retrieve the proper RST/RSTe driver. Go to the Supermicro web page for your motherboard and click on "Download the Latest Drivers and Utilities", select the proper driver, and copy it to a USB flash drive.
3. Boot from a bootable device with Windows OS installation. You can see a bootable device list by pressing **F11** during the system startup.

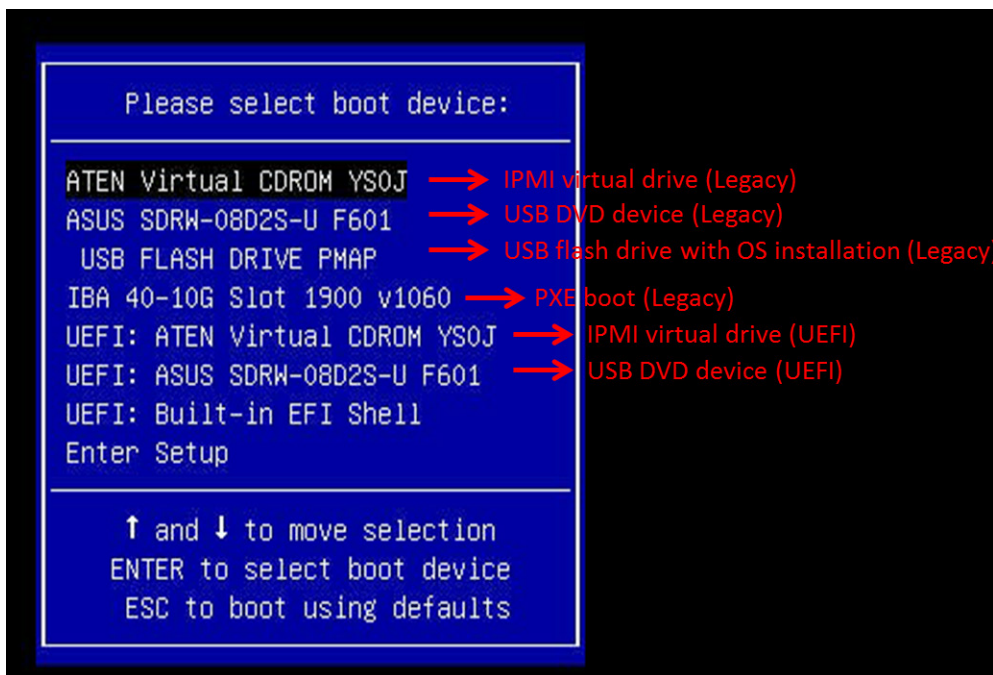
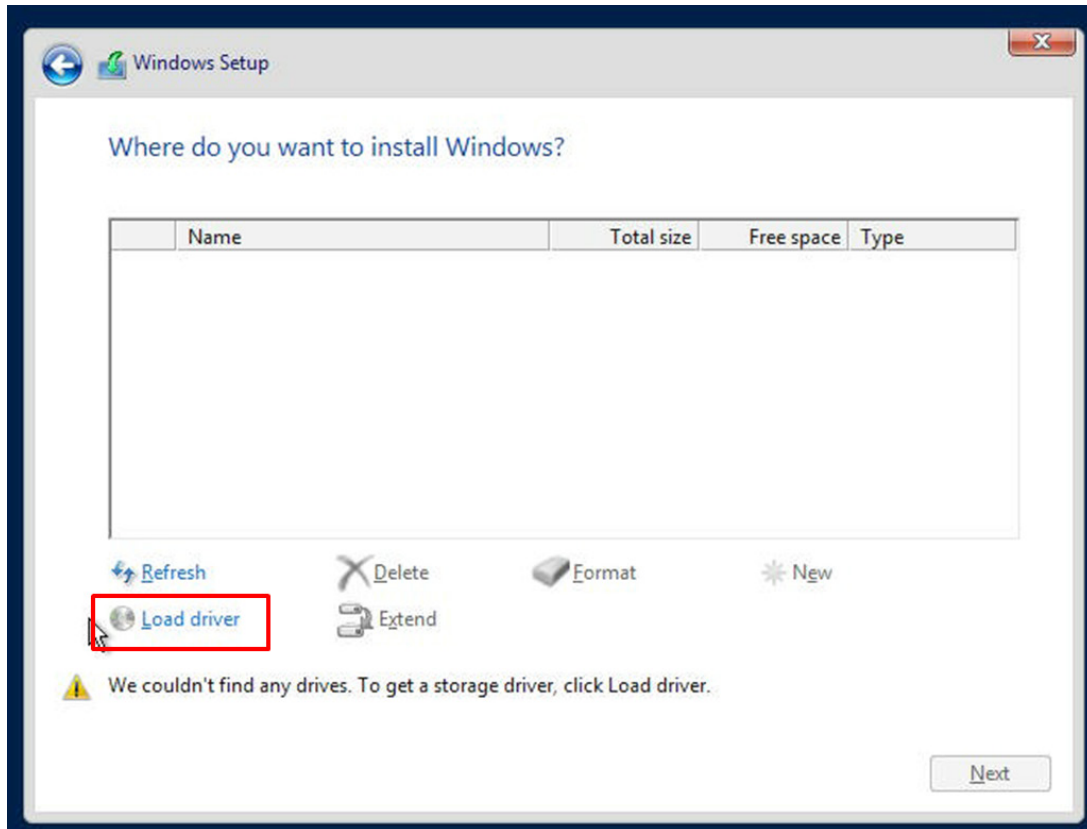

Figure A-1. Select Boot Device

4. During Windows Setup, continue to the dialog where you select the drives on which to install Windows. If the disk you want to use is not listed, click on “Load driver” link at the bottom left corner.



**Figure A-2. Load Driver Link**

To load the driver, browse the USB flash drive for the proper driver files.

- For RAID, choose the SATA/sSATA RAID driver indicated then choose the storage drive on which you want to install it.
  - For non-RAID, choose the SATA/sSATA AHCI driver indicated then choose the storage drive on which you want to install it.
5. Once all devices are specified, continue with the installation.
  6. After the Windows OS installation has completed, the system will automatically reboot multiple times.

## A.2 Driver Installation

The Supermicro website contains drivers and utilities for your system at <https://www.supermicro.com/wdl/driver>. Some of these must be installed, such as the chipset driver.

After accessing the website, go into the CDR\_Images (in the parent directory of the above link) and locate the ISO file for your motherboard. Download this file to a USB flash drive or a DVD. (You may also use a utility to extract the ISO file if preferred.)

Another option is to go to the Supermicro website at <http://www.supermicro.com/products/>. Find the product page for your motherboard, and "Download the Latest Drivers and Utilities". Insert the flash drive or disk and the screenshot shown below should appear.

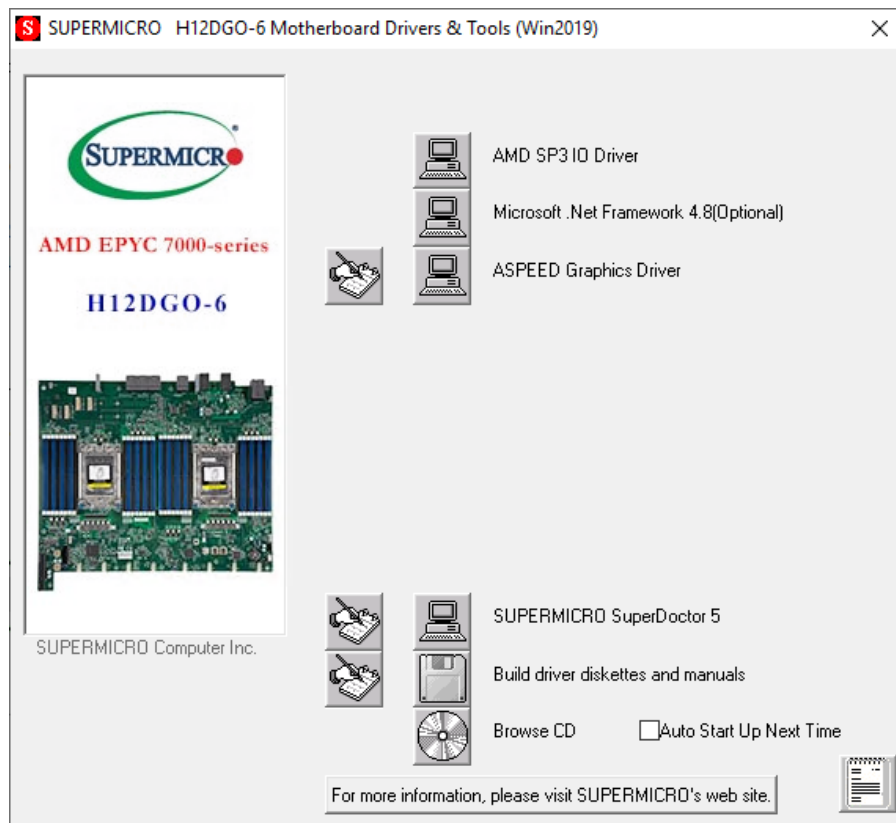

Figure A-3. Driver & Tool Installation Screen

**Note:** Click the icons showing a hand writing on paper to view the readme files for each item. Click the computer icons to the right of these items to install each item (from top to the bottom) one at a time. **After installing each item, you must re-boot the system before moving on to the next item on the list.** The bottom icon with a CD on it allows you to view the entire contents.

## A.3 SuperDoctor® 5

The Supermicro SuperDoctor 5 is a program that functions in a command-line or web-based interface for Windows and Linux operating systems. The program monitors such system health information as CPU temperature, system voltages, system power consumption, fan speed, and provides alerts via email or Simple Network Management Protocol (SNMP).

SuperDoctor 5 comes in local and remote management versions and can be used with Nagios to maximize your system monitoring needs. With SuperDoctor 5 Management Server (SSM Server), you can remotely control power on/off and reset chassis intrusion for multiple systems with SuperDoctor 5 or IPMI. SuperDoctor 5 Management Server monitors HTTP, FTP, and SMTP services to optimize the efficiency of your operation.

[SuperDoctor® Manual and Resources](#)

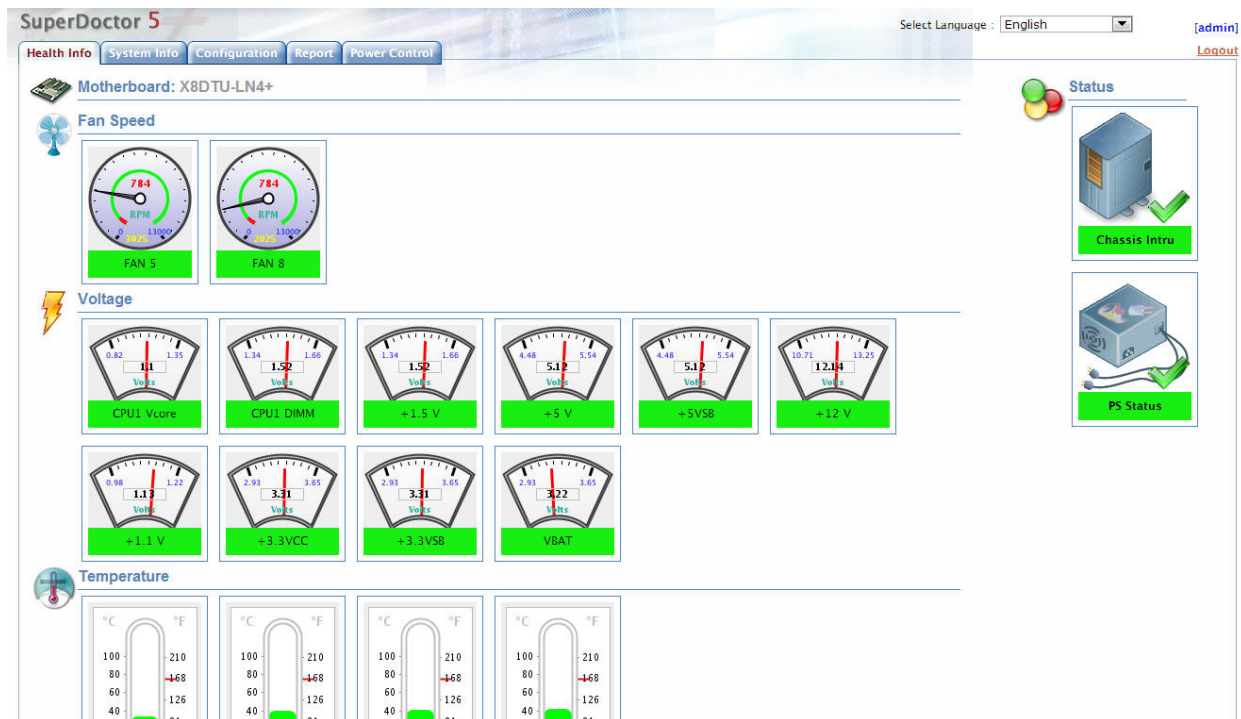

Figure A-4. SuperDoctor 5 Interface Display Screen (Health Information)

## A.4 IPMI

The H12DGO-6 supports the Intelligent Platform Management Interface (IPMI). IPMI is used to provide remote access, monitoring and management. There are several BIOS settings that are related to IPMI.

Supermicro ships standard products with a unique password for the BMC ADMIN user. This password can be found on a label on the motherboard.

For general documentation and information on IPMI, please visit our website at: <http://www.supermicro.com/products/nfo/IPMI.cfm>.

## Appendix B

### Standardized Warning Statements

The following statements are industry standard warnings, provided to warn the user of situations which have the potential for bodily injury. Should you have questions or experience difficulty, contact Supermicro's Technical Support department for assistance. Only certified technicians should attempt to install or configure components.

Read this section in its entirety before installing or configuring components.

These warnings may also be found on our website at [http://www.supermicro.com/about/policies/safety\\_information.cfm](http://www.supermicro.com/about/policies/safety_information.cfm).

#### B.1 Battery Handling



**Warning!** There is the danger of explosion if the battery is replaced incorrectly. Replace the battery only with the same or equivalent type recommended by the manufacturer. Dispose of used batteries according to the manufacturer's instructions

##### 電池の取り扱い

電池交換が正しく行われなかった場合、破裂の危険性があります。交換する電池はメーカーが推奨する型、または同等のものを使用下さい。使用済電池は製造元の指示に従って処分して下さい。

##### 警告

電池更換不當會有爆炸危險。請只使用同類電池或制造商推薦的功能相當的電池更換原有電池。請按製造商的說明處理廢舊電池。

##### 警告

電池更換不當會有爆炸危險。請使用製造商建議之相同或功能相當的電池更換原有電池。請按照製造商的說明指示處理廢棄舊電池。

##### Warnung

Bei Einsetzen einer falschen Batterie besteht Explosionsgefahr. Ersetzen Sie die Batterie nur durch den gleichen oder vom Hersteller empfohlenen Batterietyp. Entsorgen Sie die benutzten Batterien nach den Anweisungen des Herstellers.

**Attention**

Danger d'explosion si la pile n'est pas remplacée correctement. Ne la remplacer que par une pile de type semblable ou équivalent, recommandée par le fabricant. Jeter les piles usagées conformément aux instructions du fabricant.

**¡Advertencia!**

Existe peligro de explosión si la batería se reemplaza de manera incorrecta. Reemplazar la batería exclusivamente con el mismo tipo o el equivalente recomendado por el fabricante. Desechar las baterías gastadas según las instrucciones del fabricante.

**אזהרה!**

קיימת סכנת פיצוץ של הסוללה במידה והוחלפה בדרך לא תקינה. יש להחליף את הסוללה בסוג התואם מחברת יצרן מומלצת.

סילוק הסוללות המשומשות יש לבצע לפי הוראות היצרן.

هناك خطر من انفجار في حالة استبدال البطارية بطريقة غير صحيحة فعليك استبدال البطارية فقط بنفس النوع أو ما يعادلها كما أوصت به الشركة المصنعة تخلص من البطاريات المستعملة وفقا لتعليمات الشركة الصانعة

**경고!**

배터리가 올바르게 교체되지 않으면 폭발의 위험이 있습니다. 기존 배터리와 동일하거나 제조사에서 권장하는 동등한 종류의 배터리로만 교체해야 합니다. 제조사의 안내에 따라 사용된 배터리를 처리하여 주십시오.

**Waarschuwing**

Er is ontploffingsgevaar indien de batterij verkeerd vervangen wordt. Vervang de batterij slechts met hetzelfde of een equivalent type die door de fabrikant aanbevolen wordt. Gebruikte batterijen dienen overeenkomstig fabrieksvoorschriften afgevoerd te worden.

## B.2 Product Disposal



**Warning!** Ultimate disposal of this product should be handled according to all national laws and regulations.

### 製品の廃棄

この製品を廃棄処分する場合、国の関係する全ての法律・条例に従い処理する必要があります。

### 警告

本产品的废弃处理应根据所有国家的法律和规章进行。

### 警告

本產品的廢棄處理應根據所有國家的法律和規章進行。

### Warnung

Die Entsorgung dieses Produkts sollte gemäß allen Bestimmungen und Gesetzen des Landes erfolgen.

### ¡Advertencia!

Al deshacerse por completo de este producto debe seguir todas las leyes y reglamentos nacionales.

### Attention

La mise au rebut ou le recyclage de ce produit sont généralement soumis à des lois et/ou directives de respect de l'environnement. Renseignez-vous auprès de l'organisme compétent.

### סילוק המוצר

אזהרה!

סילוק סופי של מוצר זה חייב להיות בהתאם להנחיות וחוקי המדינה.

عند التخلص النهائي من هذا المنتج ينبغي التعامل معه وفقا لجميع القوانين واللوائح الوطنية

### 경고!

이 제품은 해당 국가의 관련 법규 및 규정에 따라 폐기되어야 합니다.

### Waarschuwing

De uiteindelijke verwijdering van dit product dient te geschieden in overeenstemming met alle nationale wetten en reglementen.

# Appendix C

## UEFI BIOS Recovery

**Warning:** Do not upgrade the BIOS unless your system has a BIOS-related issue. Flashing the wrong BIOS can cause irreparable damage to the system. In no event shall Supermicro be liable for direct, indirect, special, incidental, or consequential damages arising from a BIOS update. If you need to update the BIOS, do not shut down or reset the system while the BIOS is updating. Doing so may cause a boot failure.

### C.1 Overview

The Unified Extensible Firmware Interface (UEFI) provides a software-based interface between the operating system and the platform firmware in the pre-boot environment. The UEFI specification supports an architecture-independent mechanism for add-on card initialization to allow the UEFI OS loader, which is stored in the add-on card, to boot the system. The UEFI offers clean, hands-off control to a computer system at bootup.

### C.2 Recovering the UEFI BIOS Image

A UEFI BIOS flash chip consists of a recovery BIOS block and a main BIOS block (a main BIOS image). The boot block contains critical BIOS codes, including memory detection and recovery codes for the user to flash a new BIOS image if the original main BIOS image is corrupted. When the system power is on, the boot block codes execute first. Once it is completed, the main BIOS code will continue with system initialization and bootup.

### C.3 Recovering the BIOS Block with a USB Device

If the BIOS file is corrupted and the system is not able to boot up, this feature will allow you to recover the BIOS image using a USB-attached device. A USB flash drive or a USB CD/DVD ROM drive may be used for this purpose. Please note that a USB hard disk drive is NOT supported. Follow the procedures on the next page to recover the BIOS.

Using a different system, copy the standard BIOS binary image file into the root directory of a USB flash drive with FAT16 or FAT32 format and rename the file to SUPER.ROM.

**Note:** If you cannot locate the "SUPER.ROM" file in your driver disk, visit our website at [www.supermicro.com](http://www.supermicro.com) to download the correct BIOS image into a USB flash device and rename it "SUPER.ROM".

1. While the system is turned off, insert the USB device that contains the new BIOS binary image (SUPER.ROM).
2. Power on the system.



3. After the system is turned on, the system will enter the BIOS Recovery menu. Select "Proceed with flash update" to start the BIOS recovery process. **DO NOT INTERRUPT THIS PROCESS UNTIL IT FINISHED!**

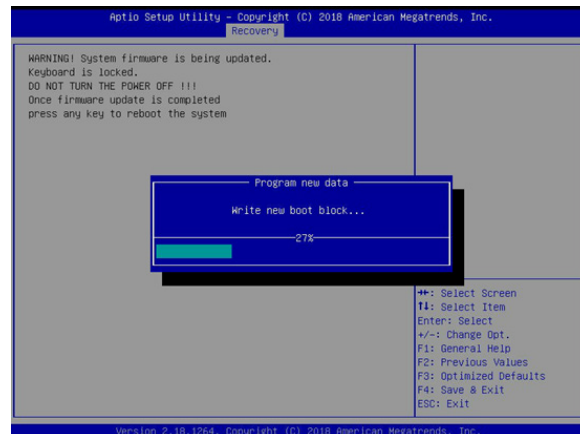
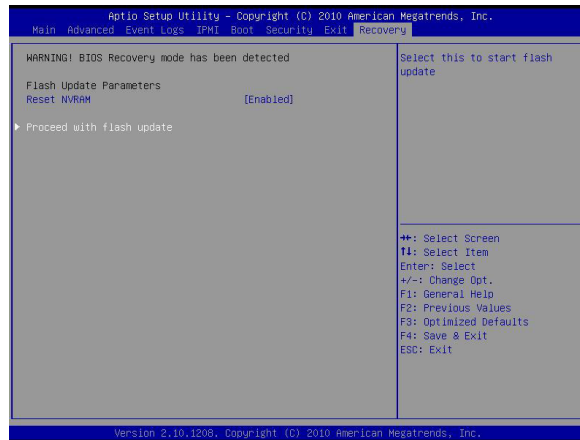

4. After the Boot Sector Recovery Process is complete, press any key to reboot the system.

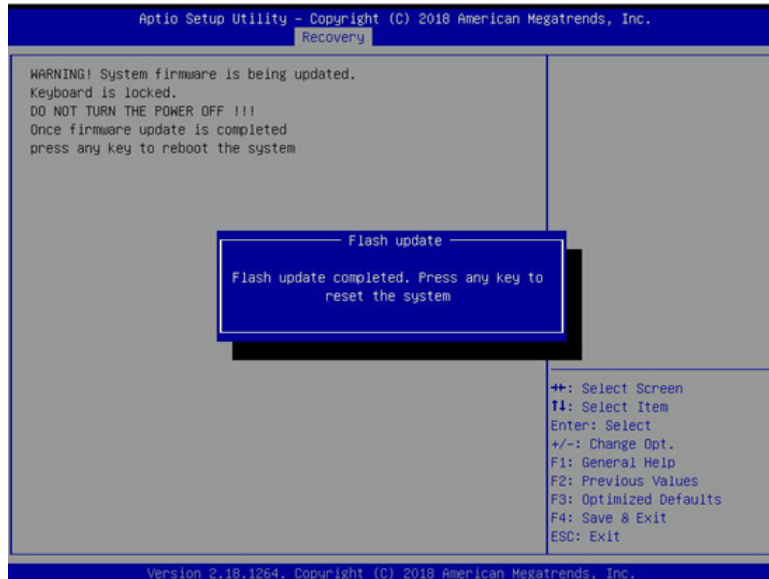
**Notes:**

- \* The BIOS recovery (SUPER.ROM) will not work if BIOS has a multi-block crash.
- \* If you have purchased an OOB license, you can do a BIOS flash again through BMC WebGUI or SUM. Please refer to these SUPERMICRO software-related videos:
- Activate OOB license: [https://www.youtube.com/watch?v=V4spX\\_DOV7I](https://www.youtube.com/watch?v=V4spX_DOV7I)
- SUPERMICO BIOS Update: <https://www.youtube.com/watch?v=S8z6iOEHGwY>
- \* If the BIOS flash recovery fails, contact our RMA Department to have the BIOS chip reprogrammed. This will require shipping the board to Supermicro for repair.
- Submit your RMA request at <https://www.supermicro.com/support/rma>
- Please make sure to follow all instructions when returning the motherboard.