

# SUPERO<sup>®</sup>

SUPER X5DE8-GG  
SUPER X5DEI-GG  
SUPER X5DEE-M

## USER'S MANUAL

Revision 1.0b

---

The information in this User's Manual has been carefully reviewed and is believed to be accurate. The vendor assumes no responsibility for any inaccuracies that may be contained in this document, makes no commitment to update or to keep current the information in this manual, or to notify any person or organization of the updates.

**Please Note: For the most up-to-date version of this manual, please see our web site at [www.supermicro.com](http://www.supermicro.com).**

SUPERMICRO COMPUTER reserves the right to make changes to the product described in this manual at any time and without notice. This product, including software, if any, and documentation may not, in whole or in part, be copied, photocopied, reproduced, translated or reduced to any medium or machine without prior written consent.

IN NO EVENT WILL SUPERMICRO COMPUTER BE LIABLE FOR DIRECT, INDIRECT, SPECIAL, INCIDENTAL, OR CONSEQUENTIAL DAMAGES ARISING FROM THE USE OR INABILITY TO USE THIS PRODUCT OR DOCUMENTATION, EVEN IF ADVISED OF THE POSSIBILITY OF SUCH DAMAGES. IN PARTICULAR, THE VENDOR SHALL NOT HAVE LIABILITY FOR ANY HARDWARE, SOFTWARE, OR DATA STORED OR USED WITH THE PRODUCT, INCLUDING THE COSTS OF REPAIRING, REPLACING, INTEGRATING, INSTALLING OR RECOVERING SUCH HARDWARE, SOFTWARE, OR DATA.

Any disputes arising between manufacturer and customer shall be governed by the laws of Santa Clara County in the State of California, USA. The State of California, County of Santa Clara shall be the exclusive venue for the resolution of any such disputes. Supermicro's total liability for all claims will not exceed the price paid for the hardware product.

---

Unless you request and receive written permission from SUPER MICRO COMPUTER, you may not copy any part of this document.

Information in this document is subject to change without notice. Other products and companies referred to herein are trademarks or registered trademarks of their respective companies or mark holders.

Copyright © 2003 by SUPER MICRO COMPUTER INC.  
All rights reserved.

**Printed in the United States of America**

## Preface

### About This Manual

This manual is written for system integrators, PC technicians and knowledgeable PC users. It provides information for the installation and use of the SUPER X5DE8-GG/X5DEI-GG/X5DEE-M serverboard. The SUPER X5DE8-GG/X5DEI-GG/X5DEE-M supports single or dual Intel® 604-pin Xeon™ processors at a 533/400 MHz front side bus - please refer to the motherboard specifications pages on our web site ([http://www.supermicro.com/Product\\_page/product-m.htm](http://www.supermicro.com/Product_page/product-m.htm)) for updates on supported processors. This product is intended to be professionally installed.

### Manual Organization

**Chapter 1** begins with a checklist of what should be included in your mainboard box, describes the features, specifications and performance of the motherboard and provides detailed information about the chipset.

**Chapter 2** begins with instructions on handling static-sensitive devices. Read this chapter when you want to install the processor and DIMM memory modules and when mounting the mainboard in the chassis. Also refer to this chapter to connect the floppy and hard disk drives, SCSI drives, the IDE interfaces, the parallel and serial ports, the keyboard and mouse, the power supply and various control panel buttons and indicators.

If you encounter any problems, see **Chapter 3**, which describes troubleshooting procedures for the video, the memory and the setup configuration stored in CMOS. For quick reference, a general FAQ [Frequently Asked Questions] section is provided. Instructions are also included for contacting technical support. In addition, you can visit our web site (at [www.supermicro.com/techsupport.htm](http://www.supermicro.com/techsupport.htm)) for more detailed information.

**Chapter 4** includes an introduction to BIOS and provides detailed information on running the CMOS Setup utility.

**Appendix A** gives information on BIOS POST messages.

**Appendix B** provides BIOS POST codes.

# Table of Contents

## Preface

About This Manual .....	iii
Manual Organization .....	iii

## Chapter 1: Introduction

1-1 Overview .....	1-1
Checklist .....	1-1
Contacting Supermicro .....	1-2
Super X5DE8-GG Image .....	1-4
Super X5DEE-M/X5DEI-GG Image .....	1-5
Super X5DE8-GG Layout .....	1-6
Super X5DE8-GG Quick Reference .....	1-7
Super X5DEI-GG/X5DEE-M Layout .....	1-8
Super X5DEI-GG/X5DEE-M Quick Reference .....	1-9
Motherboard Features .....	1-10
ServerWorks GC-SL Chipset: System Block Diagram .....	1-12
1-2 Chipset Overview .....	1-13
1-3 Special Features .....	1-13
ATI Graphics Controller .....	1-13
BIOS Recovery .....	1-13
Recovery from AC Power Loss .....	1-13
1-4 PC Health Monitoring .....	1-14
1-5 ACPI Features .....	1-15
1-6 Power Supply .....	1-17
1-7 Super I/O .....	1-17

## Chapter 2: Installation

2-1 Static-Sensitive Devices .....	2-1
Precautions .....	2-1
Unpacking .....	2-1
2-2 PGA Processor and Heatsink Installation .....	2-2
2-3 Installing DIMMs .....	2-5
2-4 I/O Ports/Control Panel Connectors .....	2-6
2-5 Connecting Cables .....	2-8
ATX Power Connector .....	2-8
Processor Power Connector .....	2-8
Power LED .....	2-8
HDD LED .....	2-9

---

NIC2 LED .....	2-9
NIC1 LED .....	2-9
Overheat LED (OH) .....	2-9
Power Fail Button .....	2-9
Reset Button .....	2-10
Power Button .....	2-10
Chassis Intrusion .....	2-10
Universal Serial Bus (USB0/1) .....	2-10
Extra Universal Serial Bus Headers (USB2/3) .....	2-11
Serial Ports .....	2-11
GLAN1/2 (Ethernet Ports) .....	2-11
ATX PS/2 Keyboard and Mouse Ports .....	2-11
Fan Headers .....	2-12
Power LED/Speaker Header (JF2) .....	2-12
Third Power Supply Fail Header .....	2-12
Wake-On-LAN .....	2-13
2-6 Jumper Settings .....	2-14
Explanation of Jumpers .....	2-14
CMOS Clear .....	2-14
VGA Enable/Disable .....	2-15
Watch Dog Enable/Disable .....	2-15
System Bus Speed .....	2-15
OH/Chassis Fan Select .....	2-15
SCSI Channel Termination Enable/Disable .....	2-16
SCSI Enable/Disable .....	2-16
LAN 1/2 Enable/Disable .....	2-15
2-7 DIP Switch Settings .....	2-17
DIP Switch 1: Processor Speed .....	2-17
2-8 Onboard Indicators .....	2-17
GLAN LEDs .....	2-17
2-9 Parallel Port, Floppy/Hard Disk Drive and SCSI Connections .....	2-18
Parallel Port Connector .....	2-18
Floppy Connector .....	2-19
IDE Connectors .....	2-19
Ultra320 SCSI Connectors .....	2-20
2-10 Installing Software Drivers .....	2-21

---

## Chapter 3: Troubleshooting

3-1	Troubleshooting Procedures .....	3-1
	Before Power On .....	3-1
	No Power .....	3-1
	No Video .....	3-1
	Memory Errors .....	3-2
	Losing the System's Setup Configuration .....	3-2
3-2	Technical Support Procedures .....	3-2
3-3	Frequently Asked Questions .....	3-3
3-4	Returning Merchandise for Service .....	3-5

## Chapter 4: BIOS

4-1	Introduction .....	4-1
4-2	BIOS Features .....	4-2
4-3	Running Setup .....	4-2
4-4	Advanced Setup .....	4-4
4-5	Chipset Setup .....	4-15
4-6	PCI PnP Setup .....	4-17
4-7	Power Setup .....	4-19
4-8	Boot Setup .....	4-20
4-9	Security Setup .....	4-22
4-10	Exit .....	4-24

## Appendices:

Appendix A:	BIOS POST Messages .....	A-1
Appendix B:	BIOS POST Codes .....	B-1

# Chapter 1

## Introduction

### 1-1 Overview

#### Checklist

Congratulations on purchasing your computer motherboard from an acknowledged leader in the industry. Supermicro boards are designed with the utmost attention to detail to provide you with the highest standards in quality and performance.

Please check that the following items have been included with your motherboard. If anything listed here is damaged or missing, contact your retailer.

One (1) Supermicro Mainboard

One (1) ribbon cable for IDE devices

One (1) floppy ribbon cable

One (1) USB cable

One (1) COM port (serial) cable

One (1) I/O backpanel shield

One (1) Supermicro CD or diskettes containing drivers and utilities

One (1) User's/BIOS Manual

Two (2) Pentium 4 Xeon active heatsinks (FAN-042, retail only)

Two (2) heatsink retention clip kits (SKT-095-604)

SCSI Accessories (X5DE8-GG only)

One (1) 68-pin LVD Ultra320/160 SCSI cable

One (1) set of SCSI driver diskettes

One (1) SCSI manual

## Contacting Supermicro

### Headquarters

Address: SuperMicro Computer, Inc.  
980 Rock Ave.  
San Jose, CA 95131 U.S.A.

Tel: +1 (408) 503-8000

Fax: +1 (408) 503-8008

Email: [marketing@supermicro.com](mailto:marketing@supermicro.com) (General Information)  
[support@supermicro.com](mailto:support@supermicro.com) (Technical Support)

Web Site: [www.supermicro.com](http://www.supermicro.com)

### Europe

Address: SuperMicro Computer B.V.  
Het Sterrenbeeld 28, 5215 ML  
's-Hertogenbosch, The Netherlands

Tel: +31 (0) 73-6400390

Fax: +31 (0) 73-6416525

Email: [sales@supermicro.nl](mailto:sales@supermicro.nl) (General Information)  
[support@supermicro.nl](mailto:support@supermicro.nl) (Technical Support)  
[rma@supermicro.nl](mailto:rma@supermicro.nl) (Customer Support)

### Asia-Pacific

Address: SuperMicro, Taiwan  
D5, 4F, No. 16 Chien-Ba Road  
Chung-Ho 235, Taipei Hsien, Taiwan, R.O.C.

Tel: +886-(2) 8226-3990

Fax: +886-(2) 8226-3991

Web Site: [www.supermicro.com.tw](http://www.supermicro.com.tw)

Technical Support:

Email: [support@supermicro.com.tw](mailto:support@supermicro.com.tw)

Tel: 886-2-8228-1366, ext.132 or 139

## Notes

**Figure 1-1. SUPER X5DE8-GG Image**

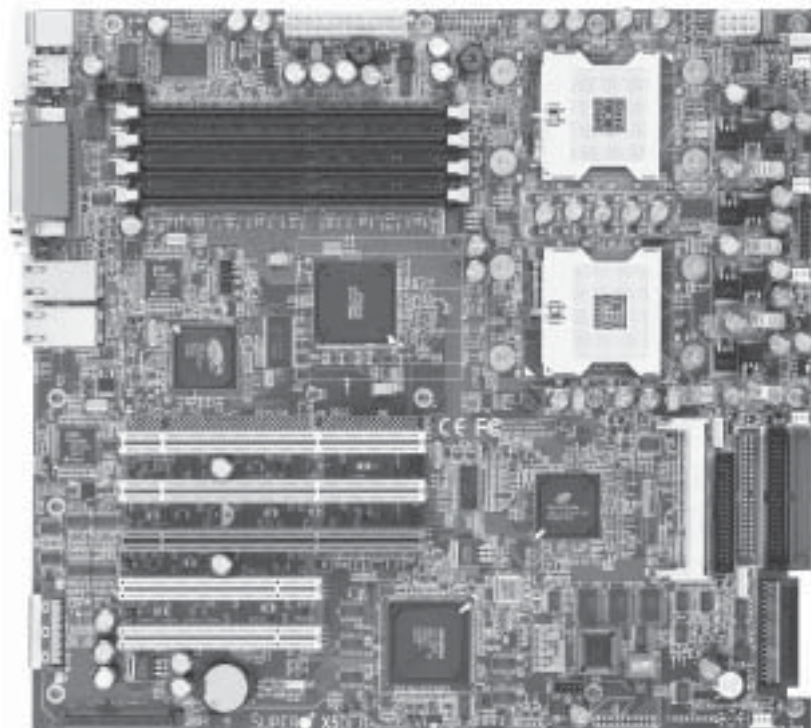

**Figure 1-2. SUPER X5DEE-M/(X5DEI-GG)\* Image**

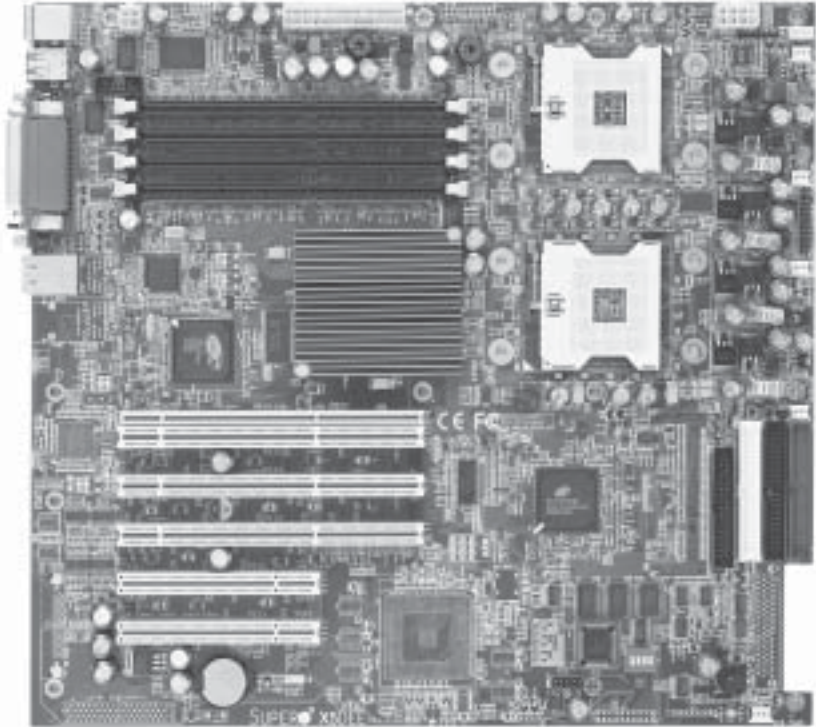

**\*Note:**

The X5DEI-GG has the same basic layout as the X5DEE-M but has two Gb Ethernet ports instead of a single 10/100 Mb Ethernet port.

**Figure 1-3. SUPER X5DE8-GG Layout**  
(not drawn to scale)

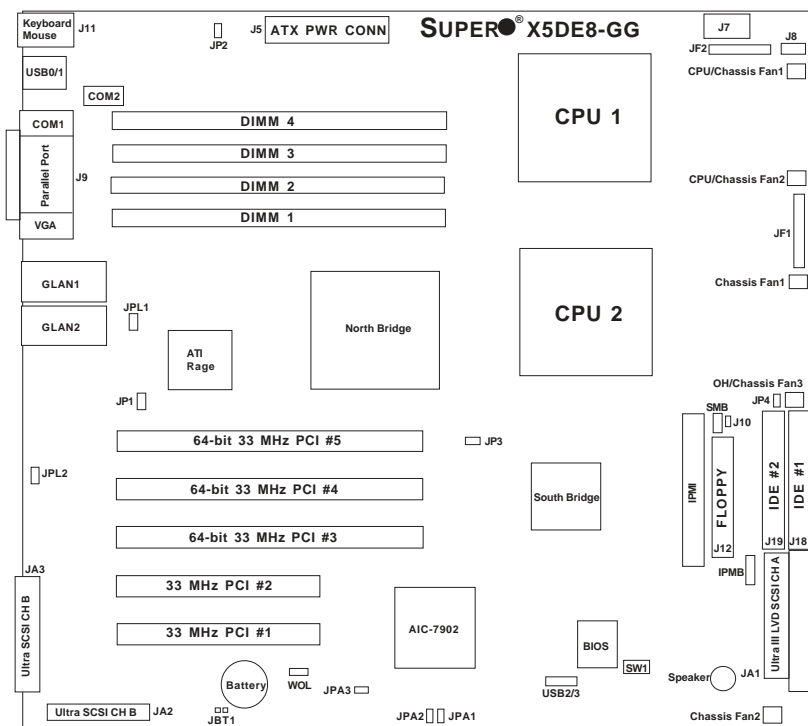

Notes: Jumpers not noted are for test purposes only.

The external SCSI port at JA3 is designed for use with rackmount chassis only.

The JA1 and JA2 ports should be used in tower configurations.

Also see Chapter 2 for the locations of the I/O ports and Front Control Panel (JF1/JF2) connectors and for details on jumper settings and pin definitions.

## X5DE8-GG Quick Reference

<b><u>Jumper</u></b>	<b><u>Description</u></b>	<b><u>Default Setting</u></b>
JBT1	CMOS Clear	See Chapter 2
JF2	Speaker Enable (page 2-12)	Close 6-7 (Enabled)
JP1	VGA Enable/Disable	Pins 1-2 (Enabled)
JP2	Watch Dog Enable/Disable	Open (Disabled)
JP3	System (Front Side) Bus Speed	Pins 1-2 (Auto MHz)
JP4	OH/Chassis Fan Select	Open (OH Fan)
JPA1/JPA2	SCSI CH A/B Termination	Open (Enabled)
JPA3	SCSI Enable/Disable	Pins 1-2 (Enabled)
JPL1	LAN1 Enable/Disable	Pins 1-2 (Enabled)
JPL2	LAN2 Enable/Disable	Pins 1-2 (Enabled)

<b><u>Switch</u></b>	<b><u>Description</u></b>
DIP Switch 1	Processor Speed

<b><u>Connector</u></b>	<b><u>Description</u></b>
ATX PWR CONN	Primary ATX Power Connector
COM1/COM2	COM1/COM2 Serial Port Connector
CPU/CHS/OH FAN	CPU/Chassis/Overheat Fan Headers
DIMM1-DIMM4	Memory (RAM) Slots
GLAN1/2	G-bit Ethernet Ports 1and 2
IPMI	IPMI 1.5 Slot (for daughter card)
J7	Processor Power Connector
J8	Third Power Supply Fail Header
J9	Parallel (Printer) Port
J10	Chassis Intrusion Header
J11	PS/2 Keyboard/Mouse Ports
J12	Floppy Disk Drive Connector
J18/19	IDE1/2 Hard Disk Drive Connector
JA1/JA2	Ultra320 LVD SCSI CH A/B Connector
JA3	Ultra SCSI CH B Connector
JF1	Front Control Panel Connector
JF2	Speaker/PWR LED Headers
JWOR	Wake-on-Ring Header
USB0/1	Universal Serial Bus Ports
USB2/3	Additional USB Headers
WOL	Wake-on-LAN Header

**Figure 1-4. SUPER X5DEI-GG/X5DEE-M Layout**  
(not drawn to scale)

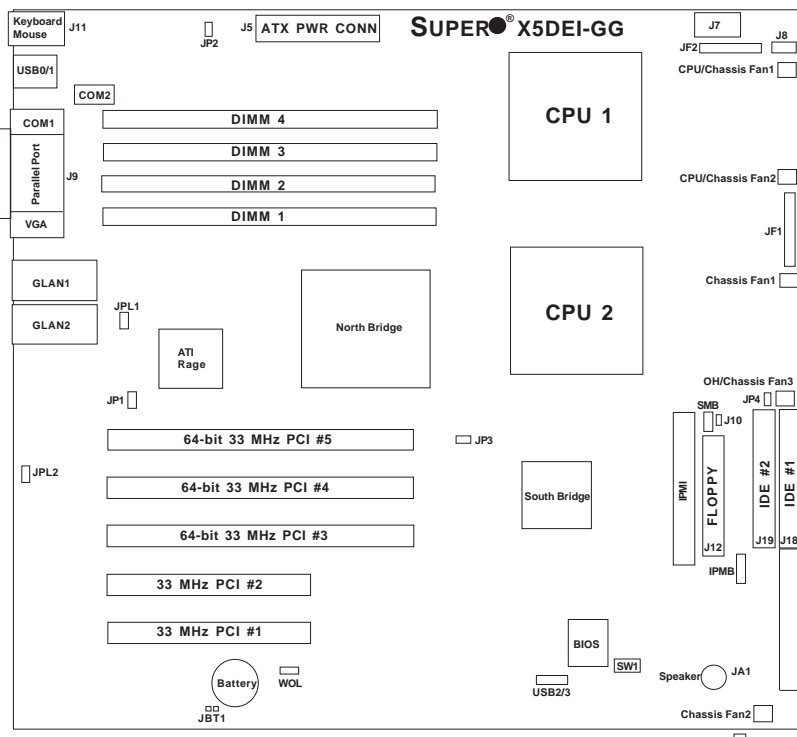

Notes: Jumpers not noted are for test purposes only.

The X5DEI-GG has two Gb Ethernet ports while the X5DEE-M has a single 10/100 Mb Ethernet port.

Also see Chapter 2 for the locations of the I/O ports and Front Control Panel (JF1/JF2) connectors and for details on jumper settings and pin definitions.

## X5DEI-GG/X5DEE-M\* Quick Reference

<b><u>Jumper</u></b>	<b><u>Description</u></b>	<b><u>Default Setting</u></b>
JBT1	CMOS Clear	See Chapter 2
JF2	Speaker Enable (page 2-12)	Close 6-7 (Enabled)
JP1	VGA Enable/Disable	Pins 1-2 (Enabled)
JP2	Watch Dog Enable/Disable	Open (Disabled)
JP3	System (Front Side) Bus Speed	Pins 1-2 (Auto MHz)
JP4	OH/Chassis Fan Select	Open (OH Fan)
JPL1*	LAN1 Enable/Disable	Pins 1-2 (Enabled)
JPL2*	LAN2 Enable/Disable	Pins 1-2 (Enabled)

<b><u>Switch</u></b>	<b><u>Description</u></b>
DIP Switch 1	Processor Speed

<b><u>Connector</u></b>	<b><u>Description</u></b>
ATX PWR CONN	Primary ATX Power Connector
COM1/COM2	COM1/COM2 Serial Port Connector
CPU/CHS/OH FAN	CPU/Chassis/Overheat Fan Headers
DIMM1-DIMM4	Memory (RAM) Slots
GLAN1/2*	G-bit Ethernet Ports 1and 2
IPMI	IPMI 1.5 Slot (for daughter card)
J7	Processor Power Connector
J8	Third Power Supply Fail Header
J9	Parallel (Printer) Port
J10	Chassis Intrusion Header
J11	PS/2 Keyboard/Mouse Ports
J12	Floppy Disk Drive Connector
J18/19	IDE1/2 Hard Disk Drive Connector
JF1	Front Control Panel Connector
JF2	Speaker/PWR LED Headers
USB0/1	Universal Serial Bus Ports
USB2/3	Additional USB Headers
WOL	Wake-on-LAN Header

\*The X5DEI-GG has two Gb Ethernet ports while the X5DEE-M has a single 10/100 Mb Ethernet port.

## Motherboard Features

### **CPU**

- Single or dual Intel® 604-pin Xeon™ processors at a 533/400 MHz front side (system) bus speed.

**Note:** Please refer to the motherboard specifications pages on our web site ([http://www.supermicro.com/Product\\_page/product-m.htm](http://www.supermicro.com/Product_page/product-m.htm)) for updates on supported processors.

### **Memory**

- Four 184-pin DIMM sockets supporting up to 4 GB of registered ECC PC2100 (DDR-266) SDRAM

**Note:** See Section 2-3 for details.

### **Chipset**

- ServerWorks GC-SL

### **Expansion Slots**

- Three 64-bit, 33 MHz PCI
- Two 32-bit, 33 MHz PCI

### **BIOS**

- 4 Mb AMI® Flash ROM
- APM 1.2, DMI 2.1, PCI 2.2, ACPI 1.0, Plug and Play (PnP), SMBIOS 2.3

### **PC Health Monitoring**

- Onboard voltage monitors for CPU cores, chipset voltage, 3.3V, +5V, +12V and 3.3V standby
- Fan status monitor with firmware/software on/off control
- CPU/chassis temperature monitors
- Environmental temperature monitor and control
- CPU fan auto-off in sleep mode
- CPU slow-down on temperature overheat
- CPU overheat LED header
- Power-up mode control for recovery from AC power loss
- Auto-switching voltage regulator for CPU core
- System overheat LED and control
- Chassis intrusion detection
- System resource alert

### **ACPI Features (optional)**

- Microsoft OnNow
- Slow blinking LED for suspend state indicator
- Main switch override mechanism

### **Onboard I/O**

- AIC-7902 for dual channel Ultra320 SCSI (X5DE8-GG)
- Zero channel SCSI RAID support (X5DE8-GG)
- Integrated ATI Rage XL graphics controller
- Two Intel 82540EM Gb Ethernet controllers (X5DE8-GG, X5DEI-GG)
- One Intel 82551 10/100 Mb Ethernet controller (X5DEE-M)
- 2 EIDE Ultra DMA/100 bus master interfaces
- 1 floppy port interface (up to 2.88 MB)
- 2 Fast UART 16550A compatible serial ports
- 1 EPP/ECP Parallel Port
- PS/2 mouse and PS/2 keyboard ports
- Up to 4 USB 1.1 (Universal Serial Bus) ports

### **Other**

- Internal/external modem ring-on
- Wake-on-LAN (WOL)
- Console redirection
- IPMI (optional)

### **CD/Diskette Utilities**

- BIOS flash upgrade utility and device drivers

### **Dimensions**

- Extended ATX: 12" x 13.05" (304.8 x 331.5 mm)

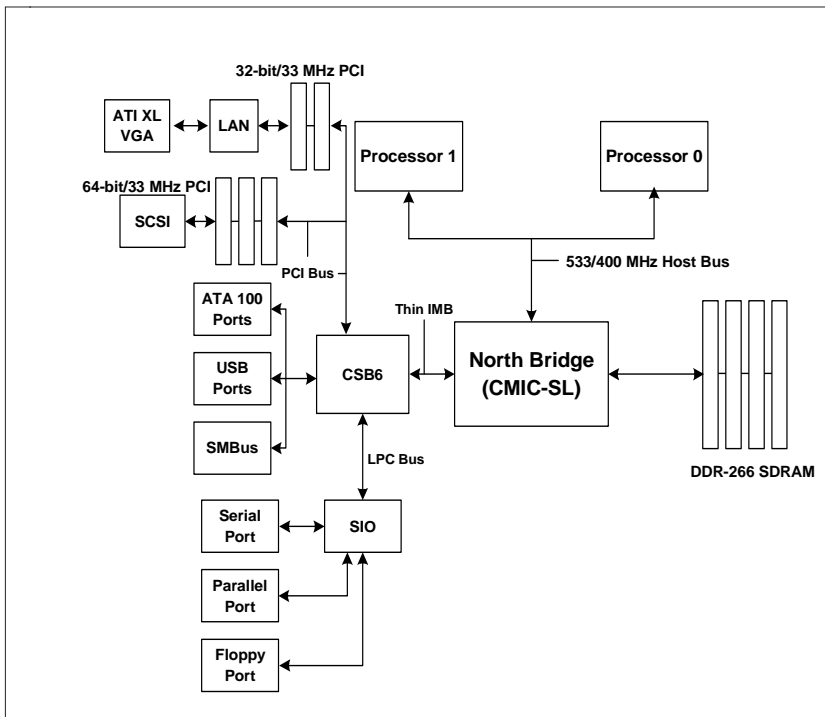

**Figure 1-5. ServerWorks Grand Champion SL Chipset:  
System Block Diagram**

**Note:** This is a general block diagram. Please see the previous Motherboard Features Section for details on the features of each motherboard.

## 1-2 Chipset Overview

The Grand Champion SL™ is a fourth-generation product of ServerWorks "Champion" chipset technology. The chipset for the X5DE8-GG/X5DEI-GG/X5DEE-M is comprised of a North Bridge (CMIC-SL) and a South Bridge (CSB6).

The North Bridge interfaces directly to the processors via a 100 MHz Host bus and integrates the functions of the main memory subsystem and the IMB bus interface unit. The memory subsystem consists of a 4-DIMM configuration accessed over a 266 MHz memory bus at a peak bandwidth of 1.6 GB/sec.

The South Bridge provides various integrated functions, including the PCI bridge and support for UDMA100, security (passwords and system protection), Plug & Play, USBs, power management, interrupt controllers and the LPC Bus.

## 1-3 Special Features

### ATI Graphics Controller

The X5DE8-GG/X5DEI-GG/X5DEE-M has an integrated ATI video controller based on the Rage XL graphics chip. The Rage XL fully supports sideband addressing and AGP texturing. This onboard graphics package can provide a bandwidth of up to 512 MB/sec over a 32-bit graphics memory bus.

### BIOS Recovery

The BIOS Recovery function allows you to recover your BIOS image file if the BIOS flashing procedure fails (see Section 3-3).

### Recovery from AC Power Loss

BIOS provides a setting for you to determine how the system will respond when AC power is lost and then restored to the system. You can choose for the system to remain powered off (in which case you must hit the power switch to turn it back on) or for it to automatically return to a power-

on state. See the Power Lost Control setting in the Advanced BIOS Setup section (Peripheral Device Configuration) to change this setting. The default setting is Always On.

## 1-4 PC Health Monitoring

This section describes the PC health monitoring features of the SUPER X5DE8-GG/X5DEI-GG/X5DEE-M. All have an onboard System Hardware Monitor chip that supports PC health monitoring.

### **Onboard Voltage Monitors for the CPU Cores, Chipset Voltage, +3.3V, +5V, +12V and +3.3V Standby**

An onboard voltage monitor will scan these voltages continuously. Once a voltage becomes unstable, a warning is given or an error message is sent to the screen. Users can adjust the voltage thresholds to define the sensitivity of the voltage monitor.

### **Fan Status Monitor with Firmware/Software On/Off Control**

The PC health monitor can check the RPM status of the cooling fans. The onboard 3-pin CPU and chassis fans are controlled by the power management functions. The thermal fan is controlled by the overheat detection logic.

### **Environmental Temperature Control**

The thermal control sensor monitors the CPU temperature in real time and will turn on the thermal control fan whenever the CPU temperature exceeds a user-defined threshold. The overheat circuitry runs independently from the CPU. It can continue to monitor for overheat conditions even when the CPU is in sleep mode. Once it detects that the CPU temperature is too high, it will automatically turn on the thermal control fan to prevent any overheat damage to the CPU. The onboard chassis thermal circuitry can monitor the overall system temperature and alert users when the chassis temperature is too high.

### **CPU Fan Auto-Off in Sleep Mode**

The CPU fan activates when the power is turned on. It continues to operate when the system enters Standby mode. When in sleep mode, the CPU will not run at full power, thereby generating less heat.

---

## **CPU Overheat LED and Control**

This feature is available when the user enables the CPU overheat warning function in the BIOS. This allows the user to define an overheat temperature. When this temperature is exceeded, both the overheat fan and the warning LED are triggered.

## **System Resource Alert**

This feature is available when used with Intel's LANDesk Client Manager (optional). LDCM is used to notify the user of certain system events. For example, if the system is running low on virtual memory and there is insufficient hard drive space for saving the data, you can be alerted of the potential problem.

## **Auto-Switching Voltage Regulator for the CPU Core**

The auto-switching voltage regulator for the CPU core can support up to 20A current and auto-sense voltage IDs ranging from 1.4V to 3.5V. This will allow the regulator to run cooler and thus make the system more stable.

## **1-5 ACPI Features**

ACPI stands for Advanced Configuration and Power Interface. The ACPI specification defines a flexible and abstract hardware interface that provides a standard way to integrate power management features throughout a PC system, including its hardware, operating system and application software. This enables the system to automatically turn on and off peripherals such as CD-ROMs, network cards, hard disk drives and printers. This also includes consumer devices connected to the PC such as VCRs, TVs, telephones and stereos.

In addition to enabling operating system-directed power management, ACPI provides a generic system event mechanism for Plug and Play and an operating system-independent interface for configuration control. ACPI leverages the Plug and Play BIOS data structures while providing a processor architecture-independent implementation that is compatible with both Windows 2000 and Windows NT 5.0.

## **Microsoft OnNow**

The OnNow design initiative is a comprehensive, system-wide approach to system and device power control. OnNow is a term for a PC that is always on but appears to be off and responds immediately to user or other requests.

## **Slow Blinking LED for Suspend-State Indicator**

When the CPU goes into a suspend state, the chassis power LED will start blinking to indicate that the CPU is in suspend mode. When the user presses any key, the CPU will wake-up and the LED will automatically stop blinking and remain on.

## **Main Switch Override Mechanism**

When an ATX power supply is used, the power button can function as a system suspend button to make the system enter a SoftOff state. The monitor will be suspended and the hard drive will spin down. Depressing the power button again will cause the whole system to wake-up. During the SoftOff state, the ATX power supply provides power to keep the required circuitry in the system alive. In case the system malfunctions and you want to turn off the power, just depress and hold the power button for 4 seconds. This option can be set in the Power section of the BIOS Setup routine.

## **External Modem Ring-On**

Wake-up events can be triggered by a device such as the external modem ringing when the system is in the SoftOff state. Note that external modem ring-on can only be used with an ATX 2.01 (or above) compliant power supply.

## **Wake-On-LAN (WOL)**

Wake-On-LAN is defined as the ability of a management application to remotely power up a computer that is powered off. Remote PC setup, updates and asset tracking can occur after hours and on weekends so that daily LAN traffic is kept to a minimum and users are not interrupted. The motherboards have a 3-pin header (WOL) to connect to the 3-pin header on

a Network Interface Card (NIC) that has WOL capability. Wake-On-LAN must be enabled in BIOS. Note that Wake-On-Lan can only be used with an ATX 2.01 (or above) compliant power supply.

## 1-6 Power Supply

As with all computer products, a stable power source is necessary for proper and reliable operation. It is even more important for processors that have high CPU clock rates.

The SUPER X5DE8-GG/X5DEI-GG/X5DEE-M accommodates ATX power supplies. Although most power supplies generally meet the specifications required by the CPU, some are inadequate. You should use one that will supply at least 400W of power and includes the additional +12V, 8-pin power connector - an even higher wattage power supply is recommended for high-load configurations. Also your power supply must supply 1.5A for the LAN port(s).

**NOTE: Auxiliary 12v power (J15) is necessary to support Intel Xeon CPUs. Failure to provide this extra power will result in the CPUs becoming unstable after only a few minutes of operation. See Section 2-5 for details on connecting the power supply cables.**

It is strongly recommended that you use a high quality power supply that meets ATX power supply Specification 2.02 or above. It must also be SSI compliant (info at <http://www.ssiforum.org/>). Additionally, in areas where noisy power transmission is present, you may choose to install a line filter to shield the computer from noise. It is recommended that you also install a power surge protector to help avoid problems caused by power surges.

## 1-7 Super I/O

The disk drive adapter functions of the Super I/O chip include a floppy disk drive controller that is compatible with industry standard 82077/765, a data separator, write pre-compensation circuitry, decode logic, data rate selection, a clock generator, drive interface control logic and interrupt and DMA logic. The wide range of functions integrated onto the Super I/O greatly reduces the number of components required for interfacing with floppy disk drives. The Super I/O supports 360 K, 720 K, 1.2 M, 1.44 M or 2.88 M disk drives and data transfer rates of 250 Kb/s, 500 Kb/s or 1 Mb/s. It also provides two high-speed, 16550 compatible serial communication ports

(UARTs), one of which supports serial infrared communication. Each UART includes a 16-byte send/receive FIFO, a programmable baud rate generator, complete modem control capability and a processor interrupt system. Both UARTs provide legacy speed with baud rate of up to 115.2 Kbps as well as an advanced speed with baud rates of 250 K, 500 K, or 1 Mb/s, which support higher speed modems.

The Super I/O supports one PC-compatible printer port (SPP), Bi-directional Printer Port (BPP) , Enhanced Parallel Port (EPP) or Extended Capabilities Port (ECP).

The Super I/O provides functions that comply with ACPI (Advanced Configuration and Power Interface), which includes support of legacy and ACPI power management through an SMI or SCI function pin. It also features auto power management to reduce power consumption.

The IRQs, DMAs and I/O space resources of the Super I/O can flexibly adjust to meet ISA PnP requirements, which support ACPI and APM (Advanced Power Management).

## Chapter 2 Installation

### 2-1 Static-Sensitive Devices

Electric-Static-Discharge (ESD) can damage electronic components. To prevent damage to your system board, it is important to handle it very carefully. The following measures are generally sufficient to protect your equipment from ESD.

#### Precautions

- Use a grounded wrist strap designed to prevent static discharge.
- Touch a grounded metal object before removing the board from the anti-static bag.
- Handle the board by its edges only; do not touch its components, peripheral chips, memory modules or gold contacts.
- When handling chips or modules, avoid touching their pins.
- Put the motherboard and peripherals back into their antistatic bags when not in use.
- For grounding purposes, make sure your computer chassis provides excellent conductivity between the power supply, the case, the mounting fasteners and the motherboard.

#### Unpacking

The motherboard is shipped in antistatic packaging to avoid static damage. When unpacking the board, make sure the person handling it is static protected.

## 2-2 PGA Processor and Heatsink Installation



*When handling the processor package, avoid placing direct pressure on the label area of the fan. Also, do not place the motherboard on a conductive surface, which can damage the BIOS battery and prevent the system from booting up.*

**IMPORTANT:** Always connect the power cord last and always remove it before adding, removing or changing any hardware components. Make sure that you install the processor into the CPU socket **before** you install the CPU heat sink. (The pictures below show a 603-pin socket.)

1. Locate the following components, which are included in the shipping package.

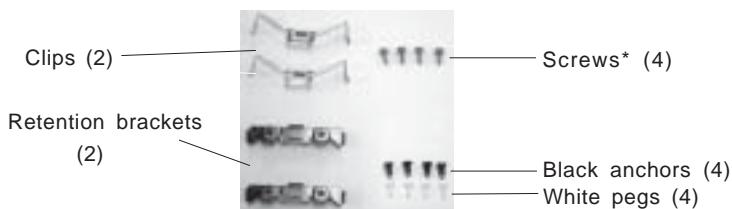

\*These screws are for mounting the motherboard to the back panel of a chassis that has four mounting holes (as shown on right).

For chassis that do not have four mounting holes, use the anchor/peg assemblies:

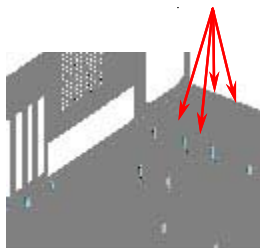

2. Insert the white pegs into the black anchors. Do not force the white pegs all the way in - only about 1/3 of the way into the black anchors.

Anchor/peg assemblies



3. Place a retention bracket in the proper position and secure it by pressing pegs into two of the retention holes until you hear a \*click\*. The clicking sound indicates that the peg is locked and secured.

Two pegs in position



One retention bracket in position

4. Secure the other retention bracket into position by repeating Step 3.



5. Lift the lever on the CPU socket: *lift the lever completely or you will damage the CPU socket when power is applied. (Install CPU1 first.)*

Socket lever



6. Insert the CPU in the socket, making sure that pin 1 of the CPU aligns with pin 1 of the socket (both corners are marked with a triangle - see Figure 2-1). When using only one CPU, install it into CPU socket #1 (socket #2 is automatically disabled if only one CPU is used).

Triangles

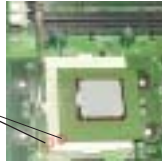

7. Press the lever down until you hear it \*click\* into the locked position.

Socket lever in locked position

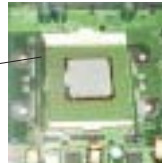

8. Apply the proper amount of thermal compound to the CPU die and place the heatsink and fan on top of the CPU.

Heatsink

CPU



9. Secure the heatsink by locking the retention clips into their proper position.

Retention clip



10. Connect the three wires of the CPU fan to the respective CPU fan connector.

CPU fan wires

CPU fan connector



**Figure 2-1. PGA604 Socket: Empty and with Processor Installed**



**Warning!** Make sure you lift the lever completely when installing the CPU. If the lever is only partly raised, damage to the socket or CPU may result.

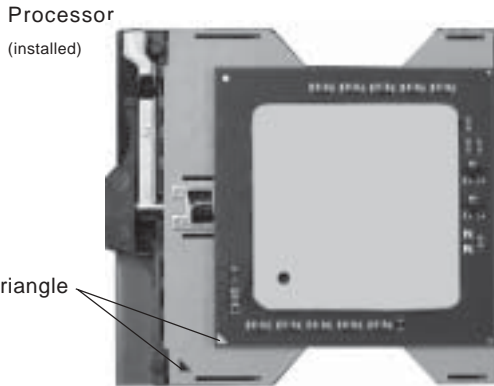
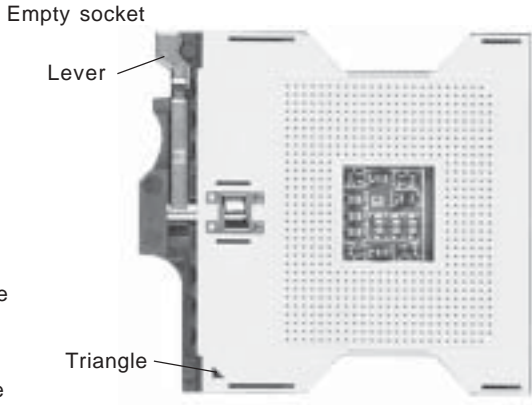

### Mounting the Motherboard in the Chassis

All motherboards have standard mounting holes to fit different types of chassis. Make sure the location of all the mounting holes for both the motherboard and the chassis match. Although a chassis may have both plastic and metal mounting fasteners, metal ones are highly recommended because they ground the motherboard to the chassis. Make sure the metal standoffs click in or are screwed in tightly. Then use a screwdriver to secure the motherboard onto the motherboard tray.

## 2-3 Installing DIMMs

**Note:** Check the Supermicro web site for recommended memory modules:  
[http://www.supermicro.com/TECHSUPPORT/FAQs/Memory\\_vendors.htm](http://www.supermicro.com/TECHSUPPORT/FAQs/Memory_vendors.htm)

---

### CAUTION

Exercise extreme care when installing or removing DIMM modules to prevent any possible damage.

---

#### DIMM Installation (See Figure 2-2)

1. Insert the desired number of DIMMs into the memory slots, starting with Bank 1.
2. Insert each DIMM module vertically into its slot. Pay attention to the notch along the bottom of the module to prevent inserting the DIMM module incorrectly.
3. Gently press down on the DIMM module until it snaps into place in the slot. Repeat for all modules (see step 1 above).

#### Memory Support

The X5DE8-GG/X5DEI-GG/X5DEE-M only supports registered ECC DDR-266 and 200 (PC2100 and PC1600) SDRAM memory. Do not mix both types.

**Figure 2-2. Installing and Removing DIMMs**

**To Install:**  
Insert module vertically and press down until it snaps into place. Pay attention to the alignment notch at the bottom.



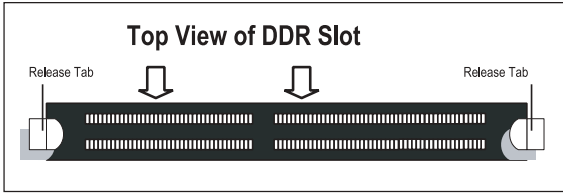

**To Remove:**

Use your thumbs to gently push near the edge of both ends of the module. This should release it from the slot.

## 2-4 I/O Ports/Control Panel Connectors

The I/O ports are color coded in conformance with the PC 99 specification. See Figure 2-3 below for the colors and locations of the various I/O ports.

**Figure 2-3. I/O Port Locations and Definitions**

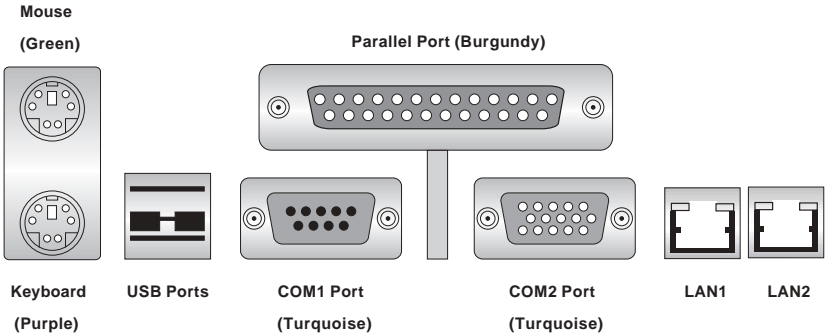

## Front Control Panel

JF1 contains header pins for various buttons and indicators that are normally located on a control panel at the front of the chassis. These connectors are designed specifically for use with Supermicro server chassis. See Figure 2-4 for the descriptions of the various control panel buttons and LED indicators. Refer to the following section for descriptions and pin definitions.

Figure 2-4. JF1 Header Pins

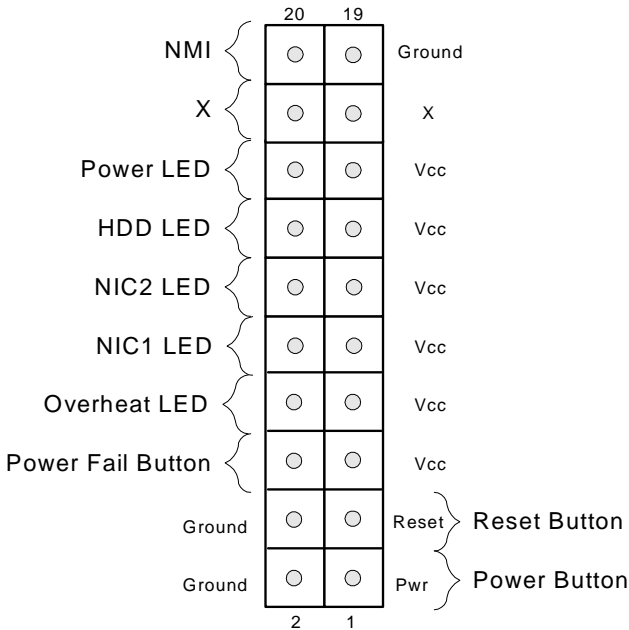

## 2-5 Connecting Cables

### ATX Power Connector

The main power supply connector on the X5DE8-GG/X5DEI-GG/X5DEE-M meets the SSI (Superset ATX) 24-pin specification, however it also supports a 20-pin power supply connector. Make sure that the orientation of the connector is correct. See the table on the right for pin definitions.

**ATX Power Supply 24-pin Connector  
Pin Definitions**

Pin Number	Definition	Pin Number	Definition
13	+3.3V	1	+3.3V
14	-12V	2	+3.3V
15	COM	3	COM
16	PS_ON#	4	+5V
17	COM	5	COM
18	COM	6	+5V
19	COM	7	COM
20	Res(NC)	8	PWR_OK
21	+5V	9	5VSB
22	+5V	10	+12V
23	+5V	11	+12V
24	COM	12	+3.3V

### Processor Power Connector

In addition to the Primary ATX power connector (above), the 12v 8-pin Processor connector at J7 must also be connected to your power supply. See the table on the right for pin definitions.

**8-Pin +12v Power Supply  
Connector (J7)**

Pins	Definition
1 thru 4	Ground
5 thru 8	+12V

### NMI Button

The non-maskable interrupt button header is located on pins 19 and 20 of JF1. Refer to the table on the right for pin definitions.

**NMI Button Pin  
Definitions (JF1)**

Pin Number	Definition
19	Ground
20	Control

### Power LED

The Power LED connection is located on pins 15 and 16 of JF1. Refer to the table on the right for pin definitions.

**PWR\_LED Pin Definitions  
(JF1)**

Pin Number	Definition
15	Vcc
16	Control

## HDD LED

The HDD LED connection (for IDE and SCSI Disk Drives) is located on pins 13 and 14 of JF1. Attach the hard drive LED cable here to display disk activity. See the table on the right for pin definitions.

**HDD LED Pin Definitions (JF1)**

Pin Number	Definition
13	Vcc
14	HD Active

## NIC2 LED

The NIC LED connection for the LAN2 port is located on pins 11 and 12 of JF1. Attach the LAN2 LED cable to display network activity. Refer to the table on the right for pin definitions.

**NIC2 LED Pin Definitions (JF1)**

Pin Number	Definition
11	Vcc
12	GND

## NIC1 LED

The NIC LED connection for the LAN1 port is located on pins 9 and 10 of JF1. Attach the LAN1 LED cable to display network activity. Refer to the table on the right for pin definitions.

**NIC1 LED Pin Definitions (JF1)**

Pin Number	Definition
9	Vcc
10	GND

## Overheat LED (OH)

Connect an LED to the OH connection on pins 7 and 8 of JF1 to provide advanced warning of chassis overheating. Refer to the table on the right for pin definitions.

**Overheat (OH) LED Pin Definitions (JF1)**

Pin Number	Definition
7	Vcc
8	GND

## Power Fail Button

The Power Fail Button connection is located on pins 5 and 6 of JF1. Refer to the table on the right for pin definitions.

**Power Fail Button Pin Definitions (JF1)**

Pin Number	Definition
5	Vcc
6	GND

## Reset Button

The Reset Button connection is located on pins 3 and 4 of JF1. Attach it to the hardware reset switch on the computer case. Refer to the table on the right for pin definitions.

**Reset Pin  
Definitions  
(JF1)**

Pin Number	Definition
3	Reset
4	Ground

## Power Button

The Power Button connection is located on pins 1 and 2 of JF1. Momentarily contacting both pins will power on/off the system. This button can also be configured to function as a suspend button (with a setting in BIOS - see Chapter 4). To turn off the power when set to suspend mode, depress the button for at least 4 seconds. Refer to the table on the right for pin definitions.

**Power Button  
Connector  
Pin Definitions  
(JF1)**

Pin Number	Definition
1	PW_ON
2	Ground

## Chassis Intrusion

A Chassis Intrusion header is located at J10. Attach the appropriate cable to inform you of a chassis intrusion.

## Universal Serial Bus (USB0/1)

Two USB ports are located beside the PS/2 keyboard/mouse ports. USB0 is the bottom connector and USB1 is the top connector. See the table on the right for pin definitions.

**Universal Serial Bus Pin Definitions  
USB0                      USB1**

USB0		USB1	
Pin Number	Definition	Pin Number	Definition
1	+5V	1	+5V
2	P0-	2	P0-
3	P0+	3	P0+
4	Ground	4	Ground
5	N/A	5	Key

## Extra Universal Serial Bus Headers

Two additional USB headers (USB2/USB2) have been included on your motherboard. You will need a USB cable to use either connection. Refer to the tables on the right for pin definitions.

Front Panel Universal Serial Bus Pin Definitions

FPUSB0/FPUSB2		FPUSB1/FPUSB3	
Pin Number	Definition	Pin Number	Definition
1	+5V	1	+5V
2	P0-	2	P0-
3	P0+	3	P0+
4	Ground	4	Ground
5	N/A	5	Key

## Serial Ports

The COM1 serial port is located under the parallel port (see Figure 2-3). COM2 is a header on the motherboard near the DIMM 4 slot. See the table on the right for pin definitions.

Serial Port Pin Definitions (COM1, COM2)

Pin Number	Definition	Pin Number	Definition
1	DCD	6	CTS
2	DSR	7	DTR
3	Serial In	8	RI
4	RTS	9	Ground
5	Serial Out	10	NC

## GLAN 1/2 (Ethernet Ports)

Two G-bit Ethernet ports (designated GLAN1 and GLAN2) are located beside the VGA port on the IO backplane. These ports accept RJ45 type cables.

**Note:** the X5DEE-M has a single 10/100 Mb port only.



## ATX PS/2 Keyboard and PS/2 Mouse Ports

The ATX PS/2 keyboard and PS/2 mouse are located on J11. See the table at right for pin definitions. (See Figure 2-3 for the locations of each.)

PS/2 Keyboard and Mouse Port Pin Definitions (J11)

Pin Number	Definition
1	Data
2	NC
3	Ground
4	VCC
5	Clock
6	NC

## Fan Headers

The X5DE8-GG/X5DEI-GG/X5DEE-M has five fan headers, which are designated CPU Chassis Fan1, CPU Chassis Fan2, Chassis Fan1, Chassis Fan2 and Overheat/Chassis Fan3. See the table on the right for pin definitions.

**Fan Header Pin Definitions**

Pin Number	Definition
1	Ground (black)
2	+12V (red)
3	Tachometer

Caution: Fan headers are DC power.

## Power LED/Speaker (JF2)

On the JF2 header, pins 1-3 are for the PWR LED and pins 4-7 are for the speaker connection. See the table on the right for speaker pin definitions. **Note:** The speaker connector pins are for use with an external speaker. If you wish to use the onboard speaker, you should close pins 6-7 with a jumper.

**Speaker Connector Pin Definitions (JF2)**

Pin Number	Function	Definition
6	+	Red wire, Speaker data
7	Key	No connection
8		Key
9		Speaker data

## Third Power Supply Fail Header

Connect a cable from your power supply to the J8 header to provide warning of power supply failure. This warning signal is passed through the PWR\_LED pin on JF2 to indicate a power failure on the chassis. See the table on the right for pin definitions.

**Third Power Supply Fail Header Pin Definitions (J8)**

Pin Number	Definition
1	P/S 1 Fail Signal
2	P/S 2 Fail Signal
3	P/S 3 Fail Signal
4	Reset (from MB)

**Note:** This feature is only available when using redundant Supermicro power supplies.

## Wake-On-LAN

The Wake-On-LAN header is designated WOL. See the table on the right for pin definitions. You must enable the LAN Wake-Up setting in BIOS to use this feature. You must also have a LAN card with a Wake-on-LAN connector and cable.

**Wake-On-LAN Pin  
Definitions (WOL)**

Pin Number	Definition
1	+5V Standby
2	Ground
3	Wake-up

## 2-6 Jumper Settings

### Explanation of Jumpers

To modify the operation of the motherboard, jumpers can be used to choose between optional settings. Jumpers create shorts between two pins to change the function of the connector. Pin 1 is identified with a square solder pad on the printed circuit board. See the motherboard layout pages for jumper locations.

**Note:** On two pin jumpers, "Closed" means the jumper is on and "Open" means the jumper is off the pins.

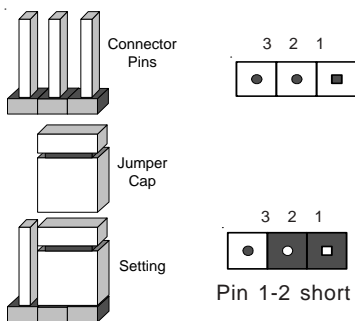

### CMOS Clear

JBT1 is used to clear CMOS. Instead of pins, this jumper consists of contact pads to prevent accidentally clearing the contents of CMOS.

To clear CMOS,

- 1) First shut down the system and unplug the power cord(s).
- 2) With the power disconnected, short the CMOS pads with a metal object such as a small screwdriver.
- 3) Remove the screwdriver (or shorting device).
- 4) Reconnect the power cord(s) and power on the system.

**Note:** Do not use the PW\_ON connector to clear CMOS.

## VGA Enable/Disable

JP1 allows you to enable or disable the VGA port. The default position is on pins 1 and 2 to enable VGA. See the table on the right for jumper settings.

**VGA Enable/Disable  
Jumper Settings  
(JP1)**

Jumper Position	Definition
1-2	Enabled
2-3	Disabled

## Watch Dog Enable/Disable

Use JP2 to enable or disable the Watch Dog feature. The default position is open to disable it. When enabled, Watch Dog can reboot your PC if an application is "hung up" or the system goes down. See the table on the right for jumper settings.

**Watch Dog Timer Enable/  
Disable Jumper Settings  
(JP2)**

Jumper Position	Definition
Open	Disabled
Closed	Enabled

## System Bus Speed

JP3 allows you to select the system (front side) bus speed to 400 MHz, 533 MHz or Auto. The speed you select must conform to that of your processor(s). "Auto" is the default setting and will allow BIOS to determine and set the system bus speed. See the table on the right for jumper settings.

**System Bus Speed  
Jumper Settings (JP3)**

Jumper Position	Definition
Pins 1-2	Auto
Pins 2-3	400 MHz
Off	533 MHz

## OH/Chassis Fan Select

JP4 allows you to select the function of the OH/Chassis Fan: either as an overheat fan or as a chassis fan. The default position is open to use as an overheat fan. See the table on the right for jumper settings.

**Overheat/Chassis Fan  
Select Jumper Settings  
(JP4)**

Jumper Position	Definition
Open	Overheat Fan
Closed	Chassis Fan

## SCSI Channel Termination Enable/Disable (X5DE8-GG)

Jumpers JPA1 and JPA2 allow you to enable or disable termination for each SCSI channel. Jumper JPA1 controls channel A and JPA2 controls channel B. The default setting is open to enable (terminate) both SCSI channels. If you wish to connect external SCSI devices, you should disable termination for the channel(s) you will be connecting them to. Note that the external SCSI port is for use with rackmount chassis only. See the table on the right for jumper settings.

### SCSI Channel Termination Enable/Disable Jumper Settings (JPA1, JPA2)

Jumper Position	Definition
Open	Enabled
Closed	Disabled

## SCSI Enable/Disable (X5DE8-GG)

The SCSI Termination jumper at JPA3 allows you to enable or disable the onboard SCSI controller. The normal (default) position is on pins 1-2 to enable (terminate) the onboard SCSI. See the table on the right for jumper settings.

### SCSI Enable/Disable Jumper Settings (JPA3)

Jumper Position	Definition
Pins 1-2	Enabled
Pins 2-3	Disabled

## LAN1/2 Enable/Disable

Change the setting of jumper JPL1 (for LAN1) or JPL2 (for LAN2) to enable or disable the Ethernet ports on the motherboard. See the table on the right for jumper settings. The default setting is enabled.

### LAN1/2 Enable/Disable Jumper Settings (JPL1, JPL2)

Jumper Position	Definition
Pins 1-2	Enabled
Pins 2-3	Disabled

**Note:** the X5DEE-M has a single LAN port and thus a single jumper.

## 2-7 DIP Switch Settings

### DIP Switch 1: Processor Speed

The red "DIP" switch labeled SW1 has four individual switches, which are used to set the speed of the processor.

The table on the right shows you the switch settings for the various speeds your processor may be able to run at. (This table is also silkscreened on the motherboard.)

**Note:** Most Intel processors have a fixed Core/Bus ratio that overwrites the setting of DIP Switch 1.

**Processor Speed Selection  
(DIP Switch 1)**

CPU	SW #1	SW #2	SW #3	SW #4
1.3 GHz	ON		ON	
1.4 GHz		ON	ON	
1.5 GHz	ON	ON	ON	
1.6 GHz				ON
1.7 GHz	ON			ON
1.8 GHz		ON		ON
1.9 GHz	ON	ON		ON
2.0 GHz			ON	ON
2.1 GHz	ON		ON	ON
2.2 GHz		ON	ON	ON
2.4 GHz	ON	ON	ON	ON

< Default

## 2-8 Onboard Indicators

### GLAN LEDs (X5DE8-GG, X5DEI-GG)

The Gb Ethernet LAN ports (located beside the VGA port) has two LEDs. The yellow LED indicates activity while the other LED may be green, orange or off to indicate the speed of the connection. See the table at right for the functions associated with the second LED.

**1 Gb LAN Right LED  
Indicator**

LED Color	Definition
Off	No Connection
Green	100 MHz
Orange	1 GHz

## 2-9 Parallel Port, Floppy/Hard Disk Drive and SCSI Connections

Note the following when connecting the floppy and hard disk drive cables:

- The floppy disk drive cable has seven twisted wires.
- A red mark on a wire typically designates the location of pin 1.
- A single floppy disk drive ribbon cable has 34 wires and two connectors to provide for two floppy disk drives. The connector with twisted wires always connects to drive A, and the connector that does not have twisted wires always connects to drive B.

### Parallel (Printer) Port Connector

The parallel (printer) port is located on J9. See the table on the right for pin definitions.

**Parallel (Printer) Port Pin Definitions  
(J9)**

Pin Number	Function	Pin Number	Function
1	Strobe-	2	Auto Feed-
3	Data Bit 0	4	Error-
5	Data Bit 1	6	Init-
7	Data Bit 2	8	SLCT IN-
9	Data Bit 3	10	GND
11	Data Bit 4	12	GND
13	Data Bit 5	14	GND
15	Data Bit 6	16	GND
17	Data Bit 7	18	GND
19	ACK	20	GND
21	BUSY	22	GND
23	PE	24	GND
25	SLCT	26	NC

## Floppy Connector

The floppy connector is located on JP12. See the table below for pin definitions.

**Floppy Connector Pin Definitions (JP12)**

Pin Number	Function	Pin Number	Function
1	GND	2	FDHDIN
3	GND	4	Reserved
5	Key	6	FDEDIN
7	GND	8	Index-
9	GND	10	Motor Enable
11	GND	12	Drive Select B-
13	GND	14	Drive Select A-
15	GND	16	Motor Enable
17	GND	18	DIR-
19	GND	20	STEP-
21	GND	22	Write Data-
23	GND	24	Write Gate-
25	GND	26	Track 00-
27	GND	28	Write Protect-
29	GND	30	Read Data-
31	GND	32	Side 1 Select-
33	GND	34	Diskette

## IDE Connectors

There are no jumpers to configure the onboard IDE#1 and #2 connectors (at J18 and J19, respectively). See the table on the right for pin definitions.

**IDE Connector Pin Definitions  
(J18, J19)**

Pin Number	Function	Pin Number	Function
1	Reset IDE	2	GND
3	Host Data 7	4	Host Data 8
5	Host Data 6	6	Host Data 9
7	Host Data 5	8	Host Data 10
9	Host Data 4	10	Host Data 11
11	Host Data 3	12	Host Data 12
13	Host Data 2	14	Host Data 13
15	Host Data 1	16	Host Data 14
17	Host Data 0	18	Host Data 15
19	GND	20	Key
21	DRQ3	22	GND
23	I/O Write-	24	GND
25	I/O Read-	26	GND
27	IOCHRDY	28	BALE
29	DACK3-	30	GND
31	IRQ14	32	IOCS16-
33	Addr 1	34	GND
35	Addr 0	36	Addr 2
37	Chip Select 0	38	Chip Select 1-
39	Activity	40	GND

## Ultra320 SCSI Connectors (X5DE8-GG)

Refer to the table below for the pin definitions of the Ultra320 SCSI connectors located at JA1 and JA2.

68-pin Ultra320/160 SCSI Connectors (JA1, JA2)

Connector Contact Number	Signal Names	Connector Contact Number	Signal Names
1	+DB(12)	35	-DB(12)
2	+DB(13)	36	-DB(13)
3	+DB(14)	37	-DB(14)
4	+DB(15)	38	-DB(15)
5	+DB(P1)	39	-DB(P1)
6	+DB(0)	40	-DB(0)
7	+DB(1)	41	-DB(1)
8	+DB(2)	42	-DB(2)
9	+DB(3)	43	-DB(3)
10	+DB(4)	44	-DB(4)
11	+DB(5)	45	-DB(5)
12	+DB(6)	46	-DB(6)
13	+DB(7)	47	-DB(7)
14	+DB(P)	48	-DB(P)
15	GROUND	49	GROUND
16	DIFFSENS	50	GROUND
17	TERMPWR	51	TERMPWR
18	TERMPWR	52	TERMPWR
19	RESERVED	53	RESERVED
20	GROUND	54	GROUND
21	+ATN	55	-ATN
22	GROUND	56	GROUND
23	+BSY	57	-BSY
24	+ACK	58	-ACK
25	+RST	59	-RST
26	+MSG	60	-MSG
27	+SEL	61	-SEL
28	+C/D	62	-C/D
29	+REQ	63	-REQ
30	+I/O	64	-I/O
31	+DB(8)	65	-DB(8)
32	+DB(9)	66	-DB(9)
33	+DB(10)	67	-DB(10)
34	+DB(11)	68	-DB(11)

## 2-10 Installing Software Drivers

After all the hardware has been installed you must install the software drivers. The necessary drivers are all included on the Supermicro CD that came packaged with your motherboard. After inserting this CD into your CD-ROM drive, the display shown in Figure 2-5 should appear. (If this display does not appear, click on the My Computer icon and then on the icon representing your CD-ROM drive. Finally, double click on the S "Setup" icon.)

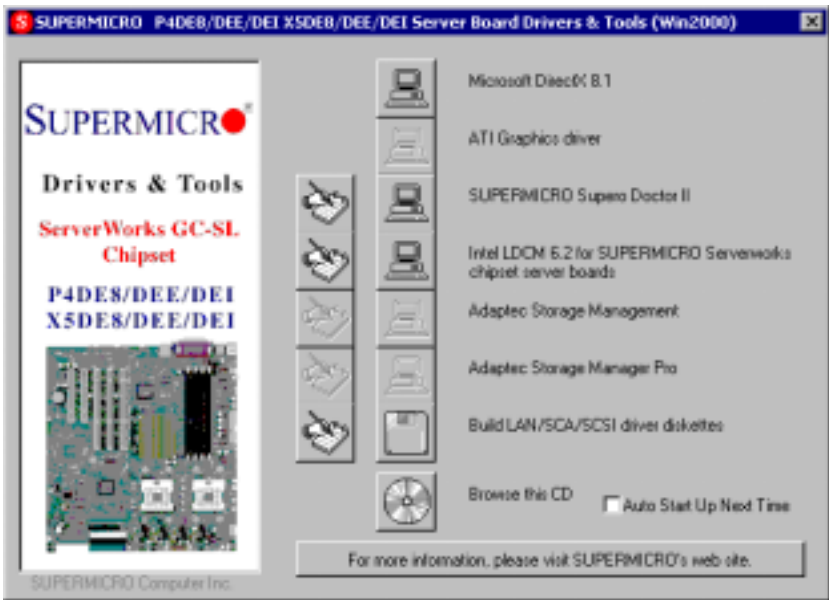

Figure 2-5. Driver/Tool Installation Display Screen

Click the icons showing a hand writing on paper to view the readme files for each item. The bottom icon with a CD on it allows you to view the entire contents of the CD.

## Notes

## Chapter 3

# Troubleshooting

### 3-1 Troubleshooting Procedures

Use the following procedures to troubleshoot your system. If you have followed all of the procedures below and still need assistance, refer to the 'Technical Support Procedures' and/or 'Returning Merchandise for Service' section(s) in this chapter.

**Note: Always disconnect the power cord before adding, changing or installing any hardware components.**

#### Before Power On

1. Make sure no short circuits exist between the motherboard and chassis.
2. Disconnect all ribbon/wire cables from the motherboard, including those for the keyboard and mouse.
3. Remove all add-on cards.
4. Install one CPU (making sure it is fully seated) and connect the chassis speaker and the power LED to the motherboard. (Check all jumper settings as well.)

#### No Power

1. Make sure no short circuits exist between the motherboard and the chassis.
2. Verify that all jumpers are set to their default positions.
3. Check that the 115V/230V switch on the power supply is properly set.
4. Turn the power switch on and off to test the system.
5. The battery on your motherboard may be old. Check to verify that it still supplies ~3VDC. If it does not, replace it with a new one.

#### No Video

1. If the power is on but you have no video, remove all the add-on cards and cables.
2. Use the speaker to determine if any beep codes exist. Refer to the Appendix for details on beep codes.

---

### **NOTE**

If you are a system integrator, VAR or OEM, a POST diagnostics card is recommended. For I/O port 80h codes, refer to App. B.

---

### **Memory Errors**

1. Make sure the DIMM modules are properly and fully installed.
2. Determine if different speeds of DIMMs have been installed and verify that the BIOS setup is configured for the fastest speed of RAM used. It is recommended to use the same RAM speed for all DIMMs in the system.
3. Make sure you are using registered ECC, PC1600 or PC2100 DDR-RAM. EDO SDRAM and PC100/133 SDRAM are not supported.
4. Check for bad DIMM modules or slots by swapping a single module between two slots and noting the results.
5. Make sure all memory modules are fully seated in their slots. See Chapter 2 Section 3 for details.
6. Check the position of the 115V/230V switch on the power supply.

### **Losing the System's Setup Configuration**

1. Ensure that you are using a high quality power supply. A poor quality power supply may cause the system to lose the CMOS setup information. Refer to Section 1-6 for details on recommended power supplies.
2. The battery on your motherboard may be old. Check to verify that it still supplies ~3VDC. If it does not, replace it with a new one.
3. If the above steps do not fix the Setup Configuration problem, contact your vendor for repairs.

## **3-2 Technical Support Procedures**

Before contacting Technical Support, please take the following steps. Also, note that as a motherboard manufacturer, SuperMicro does not sell directly to end-users, so it is best to first check with your distributor or reseller for troubleshooting services. They should know of any possible problem(s) with the specific system configuration that was sold to you.

1. Please go through the 'Troubleshooting Procedures' and 'Frequently Asked Question' (FAQ) sections in this chapter or see the FAQs on our website (<http://www.supermicro.com/TECHSUPPORT/TechSupport.htm>) before contacting Technical Support.
2. BIOS upgrades can be downloaded from our web site at <http://www.supermicro.com/techsupport/download.htm>.

**Note: Not all BIOS can be flashed depending on the modifications to the boot block code.**

3. If you still cannot resolve the problem, include the following information when contacting Super Micro for technical support:
  - Motherboard model and PCB revision number
  - BIOS release date/version (this can be seen on the initial display when your system first boots up)
  - System configurationAn example of a Technical Support form is on our web site at [http://www.supermicro.com/techsupport/contact\\_support.htm](http://www.supermicro.com/techsupport/contact_support.htm).
4. Distributors: For immediate assistance, please have your account number ready when placing a call to our technical support department. We can be reached by e-mail at [support@supermicro.com](mailto:support@supermicro.com) or by fax at: (408) 503-8000, option 2.

### 3-3 Frequently Asked Questions

**Question: What are the various types of memory that my motherboard can support?**

**Answer:** The X5DE8-GG/X5DEI-GG/X5DEE-M has four 184-pin DIMM slots that support up to 4 GB of registered ECC PC2100/1600 (DDR-266/200) DDR SDRAM modules. It is strongly recommended that you do not mix memory modules of different speeds and sizes. Unbuffered SDRAM, non-ECC memory and PC100/133 SDRAM modules are not supported.

**Question: How do I update my BIOS?**

**Answer:** It is recommended that you **do not** upgrade your BIOS if you are experiencing no problems with your system. Updated BIOS files are located on our web site (<http://www.supermicro.com>). Please check our BIOS warning message and the info on how to update your BIOS on our web site. Also, check the current BIOS revision and make sure it is newer than

your BIOS before downloading. Select your motherboard model and download the BIOS file to your computer. Unzip the BIOS update file and you will find the readme.txt (flash instructions), the flash.bat (BIOS flash utility) and the BIOS image (xxxxxx.rom) files. Copy these files onto a bootable floppy and reboot your system. It is not necessary to set BIOS boot block protection jumpers on the motherboard. At the DOS prompt, enter the command "flash." This will start the flash utility and give you an opportunity to save your current BIOS image. Flash the boot block and enter the name of the update BIOS image file.

**Note:** It is important to save your current BIOS and **rename it "super.rom"** in case you need to recover from a failed BIOS update. Select flash boot block, then enter the update BIOS image. Select "Y" to start the BIOS flash procedure and do not disturb your system until the flash utility displays that the procedure is complete. After updating your BIOS, please clear the CMOS then load Optimal Values in the BIOS.

**Question: After flashing the BIOS my system does not have video. How can I correct this?**

**Answer:** If the system does not have video after flashing your new BIOS, it indicates that the flashing procedure failed. To remedy this, first clear CMOS per the instructions in this manual and retry the BIOS flashing procedure. If you still do not have video, please use the following **BIOS Recovery Procedure**. First, turn your system off and place the floppy disk with the saved BIOS image file (see above FAQ) in drive A. Press and hold <CTRL> and <Home> at the same time, then turn on the power with these keys pressed until your floppy drive starts reading. Your screen will remain blank until the BIOS program is done. If the system reboots correctly, then the recovery was successful. The BIOS Recovery Procedure will not update the boot block in your BIOS.

**Question: What's on the CD that came with my motherboard?**

**Answer:** The supplied compact disc has quite a few drivers and programs that will greatly enhance your system. We recommend that you review the CD and install the applications you need. Applications on the CD include chipset drivers for Windows and security and audio drivers.

**Question: Why can't I turn off the power using the momentary power on/off switch?**

**Answer:** The instant power off function is controlled in BIOS by the Power Button Mode setting. When the On/Off feature is enabled, the motherboard will have instant off capabilities as long as the BIOS has control of the system. When the Standby or Suspend feature is enabled or when the BIOS is not in control such as during memory count (the first screen that appears when the system is turned on), the momentary on/off switch must be held for more than four seconds to shut down the system. This feature is required to implement the ACPI features on the motherboard.

**Question: I see some of my PCI devices sharing IRQs, but the system seems to be fine. Is this correct or not?**

**Answer:** Some PCI Bus Mastering devices can share IRQs without performance penalties. These devices are designed to work correctly while sharing IRQs. See Table 3-1, below, for details on shared IRQs.

**Table 3-1. IRQ Assignments**

PCI 1 has a dedicated IRQ (does not share)
PCI 2 has a dedicated IRQ (does not share)
PCI 3 shares an IRQ with the onboard SCSI controller
PCI 4 has a dedicated IRQ (does not share)
PCI 5 has a dedicated IRQ (does not share)

## 3-5 Returning Merchandise for Service

A receipt or copy of your invoice marked with the date of purchase is required before any warranty service will be rendered. You can obtain service by calling your vendor for a Returned Merchandise Authorization (RMA) number. When returning to the manufacturer, the RMA number should be prominently displayed on the outside of the shipping carton, and mailed prepaid or hand-carried. Shipping and handling charges will be applied for all orders that must be mailed when service is complete.

This warranty only covers normal consumer use and does not cover damages incurred in shipping or from failure due to the alternation, misuse, abuse or improper maintenance of products.

During the warranty period, contact your distributor first for any product problems.

**Notes**

# Chapter 4

## BIOS

### 4-1 Introduction

This chapter describes the AMIBIOS for the X5DE8-GG/X5DEI-GG/X5DEE-M. The AMI ROM BIOS is stored in a Flash EEPROM and can be easily upgraded using a floppy disk-based program.

**Note:** Due to periodic changes to BIOS, some settings may have been added or deleted and might not yet be recorded in this manual. Refer to the Manual Download area of our web site for any changes to BIOS that are not reflected in this manual.

#### System BIOS

The BIOS is the Basic Input Output System used in all IBM® PC, XT™, AT®, and PS/2® compatible computers. The BIOS ROM stores the system parameters, such as amount of memory, type of disk drives and video displays, etc. BIOS ROM requires very little power. When the computer is turned off, a back-up battery provides power to the BIOS ROM, enabling it to retain the system parameters. Each time the computer is powered-on, the computer is then configured with the values stored in the BIOS ROM by the system BIOS, which gains control when the computer is powered on.

#### How To Change the Configuration Data

The configuration data that determines the system parameters may be changed by entering the BIOS Setup utility. This Setup utility can be accessed by pressing <Del> at the appropriate time during system boot.

#### Starting the Setup Utility

Normally, the only visible POST (Power On Self Test) routine is the memory test. As the memory is being tested, press the <Delete> key to enter the main menu of the BIOS Setup utility. From the main menu, you can access the other setup screens, such as the Chipset and Power menus. Section 4-3 gives detailed descriptions of each parameter setting in the Setup utility.

An AMIBIOS identification string is displayed at the left bottom corner of the screen, below the copyright message.

## 4-2 BIOS Features

- Supports Plug and Play V1.0A and DMI 2.3
- Supports Intel PCI (Peripheral Component Interconnect) (PME) local bus specification 2.2
- Supports Advanced Power Management (APM) specification v 1.1
- Supports ACPI
- Supports Flash ROM

AMIBIOS supports the LS120 drive made by Matsushita-Kotobuki Electronics Industries Ltd. The LS120:

- Can be used as a boot device
- Is accessible as the next available floppy drive

AMIBIOS supports PC Health Monitoring chips. When a failure occurs in a monitored activity, AMIBIOS can sound an alarm and display a message. The PC Health Monitoring chips monitor:

- CPU temperature
- Chassis intrusion detector
- Five positive voltage inputs
- Three fan speed monitor inputs

## 4-3 Running Setup

*\*Optimal default settings are in bold text unless otherwise noted.*

The BIOS setup options described in this section are selected by choosing the appropriate text from the Standard Setup screen. All displayed text is described in this section, although the screen display is often all you need to understand how to set the options (see on next page).

## The Main BIOS Setup Menu

Press the <Delete> key during the POST (Power On Self Test) to enter the Main Menu of the BIOS Setup Utility. All Main Setup options are described in this section. The Main BIOS Setup screen is displayed below.

BIOS SETUP UTILITY							
Main	Advanced	Chipset	PCI/PnP	Power	Boot	Security	Exit
AMIBIOS Version:		07.00xx					
BIOS Build Date:		05/22/02					
BIOS ID:		4DS80603					
Processor Type:		Intel®Xeon®					
Processor Speed:		2400 MHz					
System Memory:		2048 MB					
System Date		[10:10:00]					↔ Select Screen
System Time		[05/29/02]					↑↓ Select Item
							+ - Change Option
							F1 General Help
							F10 Save and Exit
							ESC Exit
V07.00 (C)Copyright 1985-2001, American Megatrends, Inc.							

Use the Up/Down arrow keys or the <Tab> key to move between the different settings in the above menu.

When the items "System Time", and "System Date" are highlighted, type in the correct time/date in the time field, and then press "Enter". The date must be entered in MM/DD/YY format. The time is entered in HH:MM:SS format. The time is in also 24-hour format. For example, 5:30 a.m. appears as 05:30:00 and 5:30 p.m. as 17:30:00.

Press the <ESC> key to exit the Main Menu and use the Left/Right arrow keys to enter the the other categories of BIOS settings. The next section is described in detail to illustrate how to navigate through the menus.

**Note:** Items displayed in gray are preset and cannot be selected. Items with a blue arrow are commands, not options (i.e. Discard Changes).

## 4-4 Advanced BIOS Setup

Choose Advanced BIOS Setup from the AMIBIOS Setup Utility main menu with the Left/Right arrow keys. You should see the following display. Select one of the items in the left frame of the screen, such as SuperIO Configuration, to go to the sub screen for that item. Advanced BIOS Setup options are displayed by highlighting the option using the arrow keys. All Advanced BIOS Setup options are described in this section.

BIOS SETUP UTILITY	
Main	Advanced
Chipset PCI/PnP Power Boot Security Exit  Setup Warning Setting items on this screen to incorrect values may cause the system to malfunction!  > SuperIO Configuration > IDE Configuration > Floppy Configuration > Boot Settings Configuration > Event Log Configuration > Peripheral Device Configuration > System Health Monitor > Remote Access Configuration	Configure SuperIO Chipset Winbond627F       ← Select Screen ↑↓ Select Item Enter Go to Sub Screen F1 General Help F10 Save and Exit ESC Exit
V7.00 (C)Copyright 1985-2001, American Megatrends, Inc.	

Use the Up/Down arrow keys to select the "Super I/O Configuration" line.

When the "Super IO Configuration" line is highlighted, hit "ENTER" to display its menu.

The following Super IO Configuration screen will appear. Here you can select your options for the your computer's I/O (Input/Output) devices.

## Super IO Configuration

BIOS SETUP UTILITY	
Main	<b>Advanced</b> Chipset PCIPnP Power Boot Security Exit
Serial Port 1 Address	[3F8]
Serial Port 1 IRQ	[4]
Serial Port 2 Address	[2F8]
Serial Port 2 IRQ	[3]
Serial Port 2 Mode	[Normal]
Parallel Port Address	[378]
Parallel Port IRQ	[7]
Parallel Port Mode	[ECP]
ECP Mode DMA Channel	[3]
	↔ Select Screen ↑↓ Select Item +- Change Option F1 General Help F10 Save and Exit ESC Exit
V07.00 (C)Copyright 1985-2002, American Megatrends, Inc.	

The Super IO Configuration includes the following items:

### **Serial Port 1 Address**

This option specifies the base I/O port address of serial port 1. The settings for this item include Disabled, **3F8** and 3E8 and 2E8. Select the desired setting and then press "Enter".

### **Serial Port 1 IRQ**

This option specifies the Interrupt Request address of serial port 1. The settings for this item include Disabled, **4** and 3.

### **Serial Port 2 Address**

This option specifies the base I/O port address of serial port 2. The settings for this item include Disabled, **2F8**, 3E8 and 2E8.

### **Serial Port 2 IRQ**

This option specifies the Interrupt Request address of serial port 2. The settings for this item include Disabled, 4 and **3**.

## **Serial Port 2 Mode**

Use this option to choose the Serial Port 2 Mode. The settings are **Normal**, Sharp-IR, SIR and consumer.

## **Parallel Port Address**

This option specifies the I/O address used by the parallel port. The settings for this item include Disabled, **378**, 278 and 3BC. Select your setting and then press "Enter".

## **Parallel Port IRQ**

This option allows the user to set the Parallel Port IRQ. The settings for this item include 5 and 7.

## **Parallel Port Mode**

This option specifies the parallel port mode. The settings for this item include Normal, Bi-directional, EPP and **ECP**.

## **ECP Mode DMA Channel**

This option allows the user to set the setting for the ECP Mode of the DMA Channel. The settings for this item include 0, 1 and 3.

## **IDE Configuration**

### **Onboard PCI IDE Controller**

This option allows the user to enable or disable the integrated IDE Controller. The settings include Disabled, Primary, Second and **Both**. Select "Disabled" to disable the Integrated IDE Controller. Select "Primary" to enable the Primary IDE controller only. Select "Secondary" to enable the Secondary IDE Controller only. Select "Both" to enable both Primary and Secondary IDE Controllers.

## Primary IDE Master

When entering "Setup", BIOS automatically detects the presence of IDE devices. This displays the auto detection status of the IDE devices. You can also manually configure the IDE drives by providing the following information:

This option allows the user to configure the IDE devices. When the desired item is highlighted (selected), press "Enter" and the following screen will be displayed:

### Type

This option sets the type of device that the AMIBIOS attempts to boot from after AMIBIOS POST is completed. The settings include Not installed, **Auto**, CDROM and ARMD. The "Auto" setting allows BIOS to automatically detect the presence of the IDE controller.

### LBA/Large Mode

LBA (Logical Block Addressing) is a method of addressing data on a disk drive. In LBA mode, the maximum drive capacity is 137 GB. The settings are Disabled and **Auto**. Select "Disabled" to disable LBA mode. Select "Auto" to enable LBA mode if your device supports it and is not already formatted with the LBA mode.

### Block (Multi-Sector Transfer) Mode

This option sets the block mode multi sector transfers option. The settings include Disabled and **Auto**. Disabled: This option prevents the BIOS from using Multi-Sector Transfer on the specified channel. The data to and from the device will occur one sector at a time. Auto: This option allows the BIOS to auto detect device support for Multi-Sector Transfers on the specified channel. If supported, this option allows the BIOS to auto detect the number of sectors per block for transfer from the hard disk drive to memory. The data transfer to and from the device will occur multiple sectors at a time (if the device supports it).

## PIO Mode

IDE PIO (Programmable I/O) mode programs timing cycles between the IDE drive and the programmable IDE controller. As the PIO mode increases, the cycle time decreases. The settings are: **Auto**, 0, 1, 2, 3 and 4.

## DMA Mode

This item allows the users to select the DMA mode. The settings are: **Auto**, SWDMA0, SWDMA1, SWDMA2, MWDMA0, MWDMA1, MWDMA2, UWDMA0, UWDMA1, UWDMA2, UWDMA3 and UWDMA4. Select Auto to auto detect the DMA Mode. Select SWDMA0 through SWDMA2 to set single word DMA0 through DMA2. Select MWDMA0 through MWDMA2 to set Multi-word DMA0 through DMA2. Select UDMA0 through UDMA4 to set Ultra DMA0 through Ultra DMA4.

## S.M.A.R.T.

S.M.A.R.T stands for Self-Monitoring Analysis and Reporting Technology, a feature that can help predict impending drive failures. The settings are **Auto**, Disabled and Enabled. Select "Enabled" or "Disabled" to enable or disable the S.M.A.R.T. Select "Auto" to auto detect S.M.A.R.T.

## 32Bit Data Transfer

The settings are Auto, Disabled and **Enabled**. Select "Enabled" or "Disabled" to enable or disable the 32-bit Data Transfer function. Select "Auto" to auto detect the 32-bit Data Transfer function.

## ARMD Emulation Type

This option is used to select the ARMD emulation type used when configuring an LS120, MO (Magneto-Optical), or Iomega Zip drive. The settings are **Auto**, Floppy and HardDisk. (ARMD stands for ATA(PI) Removable Media Disk).

### **Primary IDE Slave**

When the system enters "Setup", BIOS automatically detects the presence of IDE devices. This option displays the auto detection status of IDE devices. The settings for "Primary IDE Slave" are the same as those for the "Primary IDE Master".

### **Secondary IDE Master**

This displays the status of auto detection of IDE devices. The settings for "Secondary IDE Master" are the same as those for the "Primary IDE Master".

### **Secondary IDE Slave**

This displays the status of auto detection of IDE devices. The settings for "Secondary IDE Slave" are the same as those for the "Primary IDE Master".

### **Hard Disk Write Protect**

This item allows the user to prevent the hard disk from being overwritten. The options are Enabled or **Disabled**. Disabled allows the drive to be used normally; read, write and erase functions can all be performed. Enabled prevents the hard disk from being erased. This function is effective only when the device is accessed through BIOS.

### **ATA(PI) Detect Timeout (Seconds)**

Set this option to stop the system search for ATAPI devices within the specified number of seconds. The options are 0, 5, 10, 15, 20, 25, 30 and **35** (seconds). Most ATA disk drives can be detected within 5 seconds.

### **ATA(PI) 80pin Cable Detection**

This option allows you to select the mechanism used to detect the 80-pin ATA(PI) cable. The settings are Host, Device and **Host & Device**.

## Floppy Configuration

### Floppy A

Use this option to specify which of floppy drive you have installed in the A drive. The settings are Disabled, 360 KB 5 1/4", 1.2 MB 5 1/4", 720 KB 3 1/2", **1.44 MB 3 1/2"** and 2.88 MB 3 1/2".

### Floppy B

Use this option to specify which of floppy drive you have installed in the B drive. The settings are **Disabled**, 360 KB 5 1/4", 1.2 MB 5 1/4", 720 KB 3 1/2", 1.44 MB 3 1/2" and 2.88 MB 3 1/2".

### Floppy Drive Seek

Use this option to Enable or **Disable** the floppy seek routine on bootup.

## Boot Settings Configuration

### Quick Boot

This option allows the BIOS to skip certain tests that are normally performed on boot up. You can disable the option to speed up boot time. The settings are Disabled and **Enabled**.

### Quiet Boot

If Disabled, this option will cause the normal POST messages to be displayed upon setup. When Enabled, the OEM logo is displayed instead of the POST messages. The settings are **Enabled** and Disabled.

### Add-On ROM Display Mode

Set this option to display add-on ROM (read-only memory) messages. The settings for this option are **Force BIOS** and Keep Current. Force BIOS

allows the computer to force a third party BIOS to display during system boot. Keep Current has the system display AMIBIOS information on bootup.

### **BootUp Num Lock**

This option is used to select the status of the Number Lock function on your keyboard on bootup. The settings are **On** and **Off**.

### **BootUp CPU Speed**

This option is used to set the CPU speed to either **High** or **Low**.

### **PS/2 Mouse Support**

This option specifies whether a PS/2 Mouse will be supported. Settings are **Enabled** and **Disabled**.

### **Typematic Rate**

Set this option to select the rate at which the computer repeats a key that is held down. Settings are **Fast** and **Slow**. **Fast**: This sets the rate the computer repeats a key to over 20 times per second. Under normal operations, this setting should not be changed. **Slow**: This sets the rate the computer repeats a key to under 8 times per second.

### **System Keyboard**

This option is to let the system know if a keyboard is **Present** or **Absent**.

### **Primary Display**

This option specifies the type of monitor display you have installed on the system. The settings are **Absent**, **VGA/EGA**, **Color 40 x 25**, **Color 80 x 25** and **monochrome**.

### **Parity Check**

Use this option to either **Enable** or **Disable** the use of memory parity checking.

### **Boot to OS/2**

This option can be used to boot the system to an OS/2 operating system. The settings are **No** and **Yes**.

## Wait for F1 if Error

This settings for this option are **Enabled** and Disabled. Disabled: This prevents the AMIBIOS to wait on an error for user intervention. This setting should be used if there is a known reason for a BIOS error to appear. An example would be a system administrator must remote boot the system. The computer system does not have a keyboard currently attached. If this setting is set, the system will continue to bootup in to the operating system. If 'F1' is enabled, the system will wait until the BIOS setup is entered. Enabled: This option allows the system BIOS to wait for any error. If an error is detected, pressing <F1> will enter Setup and the BIOS setting can be adjusted to fix the problem. This normally happens when upgrading the hardware and not setting the BIOS to recognize it.

## Hit "Delete" Message Display

This option tells the system to display or not display the "Hit Delete to Enter Setup" message. The settings are **Enabled** and Disabled.

## Cache

This option is for enabling or disabling the internal CPU L1 cache. Settings include Disabled, Write-Thru, **Write-Back** and Reserved. Disabled: This option prevents the system from using the internal CPU L1 cache. This setting should be used to slow the computer system down or to troubleshoot error messages. Write-Thru: This option allows the computer system to use the internal CPU L1 cache as Write-Through cache. Write-Through cache is slower than Write-Back cache. It performs write operations to the internal L1 CPU cache and system memory simultaneously. Write-Back: This option allows the computer system to use the internal CPU L1 cache as Write-Back cache. Write-Back cache is faster than Write-Through cache. Write-Back cache is a caching method in which modifications to data in the cache aren't copied to the cache source until absolutely necessary. Write-back caching is available on all CPUs supported by this BIOS. With these CPUs, write operations stored in the L1 cache aren't copied to main memory until absolutely necessary. This is the default setting.

## System BIOS Cacheable

This option enables you to move the system BIOS to the memory cache to improve performance. Settings are **Enabled** and Disabled.

## **Event Log Configuration**

### **Event Logging**

This option **Enables** or Disables the logging of events. You can use this screen to select options for the Event Log Configuration Settings. You can access sub screens to view the event log and mark all events as read. Use the up and down arrow keys to select an item, and the plus (+) and minus (-) keys to change the option setting. The settings are described on the following pages. The screen is shown below.

### **ECC Event Logging**

This option Enables or **Disables** the logging of ECC events. The events logged by AMIBIOS are post errors such as a bad BIOS, floppy errors, or hard drive errors.

### **Clear All Event Logs**

This option can be used to tell the system to clear the event log on the next boot up. The settings are **No** and Yes.

### **View Event Log**

Highlighting this and pressing <Enter> will allow you to view the unread events from the event log area.

### **Mark All Events As Read**

Highlighting [OK] and pressing <Enter> will mark all events in the log area as having been read. The settings are OK and **Cancel**.

## Peripheral Device Configuration

### **Power Lost Control**

This option determines how the system will respond when power is reapplied after a power loss condition. Choose **Last State** to automatically start up the system when power is reapplied after an AC power loss. Always Off means you must push the main power button to restart the system after power is restored.

## System Health Monitor

The BIOS continuously monitors the health of your system by measuring certain voltage levels and temperatures.

### **CPU1 Current Temperature** **CPU2 Current Temperature** **System Current Temperature**

These readings display the real-time temperatures of CPU1, CPU2 and the system. There are also several voltage level monitors as shown on the System Health Monitor screen.

### **CPU Overheat Support**

This option allows you to specify the action taken when an overheat situation occurs. The settings are **Shutdown** and Slowdown.

### **System Overheat Warning**

This option allows you to enable or disable the system overheat warning. The settings are **Enabled** and Disabled. (See Overheat Warning Temp.)

## Remote Access Configuration

### **Remote Access**

This option allows the user to redirect the console (display) through the COM port when enabled. This is useful when two computers are hooked up to a single monitor. The function keys are disabled when this setting is enabled. The settings are "Serial ANSI" and "**Disabled**."

## 4-5 Chipset Setup

Choose Chipset Setup from the AMIBIOS Setup Utility main menu. The screen is shown below. All Chipset Setup options are described following the screen.

BIOS SETUP UTILITY							
Main	Advanced	Chipset	PCIPnP	Power	Boot	Security	Exit
Memory Timing Control		[Auto]				Options for MCH	
SDRAM CAS Latency		[CAS Latency 2.5]					
MPS 1.4 Support		[Enabled]					
Hyper-threading		[Enabled]					
Watch Dog Timer		[Disabled]					
Auto DQS Setting Support		[Disabled]					
DQS Selection		[36]					
Spread Spectrum		[Disabled]					
Memory Enhance Mapping		[Enabled]					
						↔ Select Screen ↑↓ Select Item Enter Go to Sub Screen F1 General Help F10 Save and Exit ESC Exit	
V07.00 (C)Copyright 1985-2002, American Megatrends, Inc.							

### Memory Timing Control

Determines how the memory timing is controlled. **Auto** lets BIOS program the memory timing from SPD data. Manual allows the user to select the appropriate memory timing.

### SDRAM CAS Latency

This sets the CAS latency for system memory. The default setting is **CAS Latency 2.5**.

### MPS 1.4 Support

The settings for this option are **Enabled** and Disabled.

## Hyper-threading

Enables hyper-threading if supported by the operating system. Hyper-threading is a method of creating an additional "virtual" processor by using parallelism to process multiple instructions simultaneously. The settings for this option are **Enabled** and Disabled.

## Watchdog Timer

This option is used to configure the Watchdog timer. Settings are **Disabled**, 2 minutes, 5 minutes, 10 minutes and 15 minutes.

## Auto DQS Setting Support

The settings for this option are **Disabled** and Enabled.

## DQS Selection

This setting is preset.

## Spread Spectrum

Spread Spectrum is a technique used to stabilize a system that is being affected by electromagnetic interference. The settings for this option are **Disabled** and Enabled.

## Memory Enhance Mapping

The settings for this option are **Enabled** and Disabled.

## 4-6 PCI PnP Setup

Choose PCI/PnP Setup from the AMIBIOS Setup main menu. All PCI/PnP options are described in this section. The PCI/PnP Setup screen is shown below.

BIOS SETUP UTILITY	
Main Advanced Chipset <b>PCIPnP</b> Power Boot Security Exit	
Plug & Play O/S [No] Reset Config Data [No] Allocate IRQ to VGA [Yes] PCI IDE BusMaster [Disabled]	
USB Function [Enabled] Legacy USB Support [Auto] ARMD Emulation Type [Hard Disk]	
	↔ Select Screen ↑↓ Select Item +- Change Option F1 General Help F10 Save and Exit ESC Exit
V07.00 (C)Copyright 1985-2002, American Megatrends, Inc.	

### Plug & Play OS

This option specifies how Plug and Play devices will be configured. The settings are **Yes** and **No**. **No** lets BIOS configure all devices in the system. **Yes** lets the operating system (if supported) configure PnP devices not required for bootup.

### Reset Configuration Data

Choosing the **Yes** setting will cause the PnP configuration data in the BIOS to be cleared on the next boot up. Choosing the **No** setting does not force PnP data to be cleared on the next boot.

### **Allocate IRQ to PCI VGA**

This option lets you allocate an interrupt request (IRQ) to the PCI VGA adapter card (if used). The settings are **Yes** and **No**.

### **PCI IDE BusMaster**

The settings for this option are **Disabled** and **Enabled**. Enable to specify that the IDE controller on the PCI bus has bus mastering capabilities.

### **USB Function**

The settings for this option are **Disabled** and **Enabled**. Disabled prevents the use of the USB ports and Enabled allows the use of the USB ports.

### **Legacy USB Support**

This option allows you to enable support for Legacy USB. The settings are **Auto**, **Enabled** and **Disabled**.

### **ARMD Emulation Type**

This settings for this option are **Hard Disk**, **Auto** and **Floppy**.

## 4-7 Power Setup

Choose Power from the AMIBIOS Setup main menu. All Power Setup options are described in this section. The Power screen is shown below.

BIOS SETUP UTILITY	
Main	Advanced
Chipset	PCIPnP
<b>Power</b>	Boot
Security	Exit
ACPI Aware O/S	[Yes]
Power Management	[Enabled]
Power Button Mode	[On/Off]
Suspend Timeout (Minutes)	[Off]
	↔ Select Screen ↑↓ Select Item +- Change Option F1 General Help F10 Save and Exit ESC Exit
V07.00 (C)Copyright 1985-2001, American Megatrends, Inc.	

### ACPI Aware O/S

**Yes** allows the system to utilize Intel's ACPI specification. Windows 3.x®, and Windows NT® are non-ACPI aware operating systems. Windows 95®, Windows 98®, Windows ME® and Windows 2000® are ACPI-aware OS's.

### Power Management

When enabled, this option displays the following four options relating to power management. The settings are **Disabled** and Enabled.

#### Power Button Mode

This determines the function of the chassis power button, either **On/Off** or Suspend. When set to Suspend, depressing the power button when the system is running will cause it to enter a suspend state.

#### Suspend Timeout

This option specifies the length of hard disk inactivity time that should expire before entering the power conserving state. The settings are **Off**, 1, 2, 3, 4, 5, 6, 7, 8, 9 and 10 (minutes).

## 4-8 Boot Setup

Choose Boot Setup from the AMIBIOS Setup main menu. All Boot Setup options are described in this section. The Boot Setup screen is shown below.

BIOS SETUP UTILITY							
Main	Advanced	Chipset	PCIPnP	Power	Boot	Security	Exit
> <u>Boot Device Priority</u> > Hard Disk Drives > Removable Devices > ATAPI CDROM Drives					↔ Select Screen ↑↓ Select Item Enter Go to Sub Screen F1 General Help F10 Save and Exit ESC Exit		
V02.03 (C)Copyright 1985-2000, American Megatrends, Inc.							

### Boot Device Priority

#### 1st Boot Device

This option is used to specify the order of the boot sequence that will be followed from the available system devices. The settings for the 1st Boot Device are **Removable Device**, ATAPI CDROM, Hard Drive and Intel UNDI PXE-2.0 (build 082).

#### 2nd Boot Device

The settings for the 2nd Boot Device are Removable Device, **ATAPI CDROM**, Hard Drive and Intel UNDI PXE-2.0 (build 082).

### **3rd Boot Device**

The settings for the 3rd Boot Device are Removable Device, ATAPI CDROM, **Hard Drive** and Intel UNDI PXE-2.0 (build 082).

### **Hard Disk Drives**

Use this screen to view the boot sequence of hard drives that have been auto-detected or entered manually on your system.

### **Removable Devices**

Use this screen to view the boot sequence of the removable devices that have been auto-detected or entered manually on your system.

### **ATAPI CDROM Drives**

Use this screen to view the boot sequence of the ATAPI CDROM drives that have been auto-detected or entered manually on your system.

## 4-9 Security Setup

Choose Security Setup from the AMIBIOS Setup main menu. All Security Setup options are described in this section. The Security Setup screen is shown below.

BIOS SETUP UTILITY							
Main	Advanced	Chipset	PCI/PnP	Power	Boot	Security	Exit
Supervisor Password :						Not Installed	
User Password :						Not Installed	
> Change Supervisor Password							
> Change User Password							
> Clear User Password							
Boot Sector Virus Protection						[Disabled]	
						Install or Change the password.	
						↔ Select Screen	
						↑↓ Select Item	
						Enter Go to Sub Screen	
						F1 General Help	
						F10 Save and Exit	
						ESC Exit	
V02.03 (C)Copyright 1985-2000, American Megatrends, Inc.							

### Supervisor Password

### User Password

AMIBIOS provides both Supervisor and User password functions. If you use both passwords, the Supervisor password must be set first. The system can be configured so that all users must enter a password every time the system boots or when AMIBIOS Setup is executed, using either or both the Supervisor password or User password. The Supervisor and User passwords activate two different levels of password security. If you select password support, you are prompted for a 1 – 6 character password. Type the password on the keyboard. The password does not appear on the screen when typed. Make sure you write it down. If you forget it, you must clear CMOS and reconfigure. **Remember your Password!** Keep a record of the new password when the password is changed. If you forget the password, you must erase the system configuration information in CMOS.

### **Change Supervisor Password**

This option allows you to change a supervisor password that was entered previously.

### **Change User Password**

This option allows you to change a user password that was entered previously.

### **Clear User Password**

Use this option to clear the user password so that it is not required to be entered when the system boots up.

### **Boot Sector Virus Protection**

This option allows you to enable or disable a virus detection program to protect the boot sector of your hard disk drive. The settings for this option **Disabled** and Enabled. If Enabled, AMIBIOS will display a warning when any program (or virus) issues a Disk Format command or attempts to write to the boot sector of the hard disk drive.

## 4-10 Exit Setup

Choose Exit Setup from the AMIBIOS Setup main menu. All Exit Setup options are described in this section. The Exit Setup screen is shown below.

BIOS SETUP UTILITY							
Main	Advanced	Chipset	PCIPnP	Power	Boot	Security	Exit
> <u>Exit Saving Changes</u> > Exit Discarding Changes > Load Optimal Defaults > Load Fail-Safe Defaults > Discard Changes							Exit system setup with saving the changes.
↔ Select Screen ↑↓ Select Item Enter Go to Sub Screen F1 General Help F10 Save and Exit ESC Exit							
V02.03 (C)Copyright 1985-2000, American Megatrends, Inc.							

### Exit Saving Changes

Highlighting this setting and then pressing <Enter> will save any changes you made in the BIOS Setup program and then exit. Your system should then continue with the boot up procedure.

### Exit Discarding Changes

Highlighting this setting and then pressing <Enter> will ignore any changes you made in the BIOS Setup program and then exit. Your system should then continue with the boot up procedure.

**Load Optimal Defaults**

Highlighting this setting and then pressing <Enter> provides the optimum performance settings for all devices and system features.

**Load Failsafe Defaults**

Highlighting this setting and then pressing <Enter> provides the safest set of parameters for the system. Use them if the system is behaving erratically.

**Discard Changes**

Highlighting this setting and then pressing <Enter> will ignore any changes you made in the BIOS Setup program but will not exit the BIOS Setup program.

**Notes**

## Appendix A BIOS POST Messages

During the Power-On Self-Test (POST), the BIOS will check for problems. If a problem is found, the BIOS will activate an alarm or display a message. The following is a list of such BIOS messages.

### **Failure Fixed Disk**

Fixed disk is not working or not configured properly. Check to see if fixed disk is attached properly. Run Setup. Find out if the fixed-disk type is correctly identified.

### **Stuck key**

Stuck key on keyboard.

### **Keyboard error**

Keyboard not working.

### **Keyboard Controller Failed**

Keyboard controller failed test. May require replacing keyboard controller.

### **Keyboard locked - Unlock key switch**

Unlock the system to proceed.

### **Monitor type does not match CMOS - Run SETUP**

Monitor type not correctly identified in Setup

### **Shadow Ram Failed at offset: nnnn**

Shadow RAM failed at offset **nnnn** of the 64k block at which the error was detected.

### **System RAM Failed at offset: nnnn**

System RAM failed at offset **nnnn** of in the 64k block at which the error was detected.

**Extended RAM Failed at offset: nnnn** Extended memory not working or not configured properly at offset **nnnn**.

### **System battery is dead - Replace and run SETUP**

The CMOS clock battery indicator shows the battery is dead. Replace the battery and run Setup to reconfigure the system.

**System CMOS checksum bad - Default configuration used**

System CMOS has been corrupted or modified incorrectly, perhaps by an application program that changes data stored in CMOS. The BIOS installed Default Setup Values. If you do not want these values, enter Setup and enter your own values. If the error persists, check the system battery or contact your dealer.

**System timer error**

The timer test failed. Requires repair of system board.

**Real time clock error**

Real-Time Clock fails BIOS hardware test. May require board repair.

**Check date and time settings**

BIOS found date or time out of range and reset the Real-Time Clock. May require setting legal date (1991-2099).

**Previous boot incomplete - Default configuration used**

Previous POST did not complete successfully. POST loads default values and offers to run Setup. If the failure was caused by incorrect values and they are not corrected, the next boot will likely fail. On systems with control of **wait states**, improper Setup settings can also terminate POST and cause this error on the next boot. Run Setup and verify that the waitstate configuration is correct. This error is cleared the next time the system is booted.

**Memory Size found by POST differed from CMOS**

Memory size found by POST differed from CMOS.

**Diskette drive A error**

**Diskette drive B error**

Drive A: or B: is present but fails the BIOS POST diskette tests. Check to see that the drive is defined with the proper diskette type in Setup and that the diskette drive is attached correctly.

**Incorrect Drive A type - run SETUP**

Type of floppy drive A: not correctly identified in Setup.

**Incorrect Drive B type - run SETUP**

Type of floppy drive B: not correctly identified in Setup.

**System cache error - Cache disabled**

RAM cache failed and BIOS disabled the cache. On older boards, check the cache jumpers. You may have to replace the cache. See your dealer. A disabled cache slows system performance considerably.

**CPUID:**

CPU socket number for Multi-Processor error.

**EISA CMOS not writeable**

ServerBIOS2 test error: Cannot write to EISA CMOS.

**DMA Test Failed**

ServerBIOS2 test error: Cannot write to extended **DMA** (Direct Memory Access) registers.

**Software NMI Failed**

ServerBIOS2 test error: Cannot generate software NMI (Non-Maskable Interrupt).

**Fail-Safe Timer NMI Failed**

ServerBIOS2 test error: Fail-Safe Timer takes too long.

**device Address Conflict**

Address conflict for specified **device**.

**Allocation Error for: device**

Run ISA or EISA Configuration Utility to resolve resource conflict for the specified **device**.

**CD ROM Drive**

CD ROM Drive identified.

**Entering SETUP ...**

Starting Setup program

**Failing Bits: nnnn**

The hex number **nnnn** is a map of the bits at the RAM address which failed the memory test. Each 1 (one) in the map indicates a failed bit. See errors 230, 231, or 232 above for offset address of the failure in System, Extended, or Shadow memory.

**Fixed Disk n**

Fixed disk n (0-3) identified.

**Invalid System Configuration Data**

Problem with NVRAM (CMOS) data.

**I/O device IRQ conflict**

I/O device IRQ conflict error.

**PS/2 Mouse Boot Summary Screen:**

PS/2 Mouse installed.

**nnnn kB Extended RAM Passed**

Where nnnn is the amount of RAM in kilobytes successfully tested.

**nnnn Cache SRAM Passed**

Where nnnn is the amount of system cache in kilobytes successfully tested.

**nnnn kB Shadow RAM Passed**

Where nnnn is the amount of shadow RAM in kilobytes successfully tested.

**nnnn kB System RAM Passed**

Where nnnn is the amount of system RAM in kilobytes successfully tested.

**One or more I2O Block Storage Devices were excluded from the Setup Boot Menu**

There was not enough room in the IPL table to display all installed I2O block-storage devices.

**Operating system not found**

Operating system cannot be located on either drive A: or drive C:. Enter Setup and see if fixed disk and drive A: are properly identified.

**Parity Check 1 nnnn**

Parity error found in the system bus. BIOS attempts to locate the address and display it on the screen. If it cannot locate the address, it displays ?????. Parity is a method for checking errors in binary data. A parity error indicates that some data has been corrupted.

**Parity Check 2 nnnn**

Parity error found in the I/O bus. BIOS attempts to locate the address and display it on the screen. If it cannot locate the address, it displays **????**.

**Press <F1> to resume, <F2> to Setup, <F3> for previous**

Displayed after any recoverable error message. Press <F1> to start the boot process or <F2> to enter Setup and change the settings. Press <F3> to display the previous screen (usually an initialization error of an **Option ROM**, i.e., an add-on card). Write down and follow the information shown on the screen.

**Press <F2> to enter Setup**

Optional message displayed during POST. Can be turned off in Setup.

**PS/2 Mouse:**

PS/2 mouse identified.

**Run the I2O Configuration Utility**

One or more unclaimed block storage devices have the Configuration Request bit set in the LCT. Run an I2O Configuration Utility (e.g. the SAC utility).

**System BIOS shadowed**

System BIOS copied to shadow RAM.

**UMB upper limit segment address: nnnn**

Displays the address **nnnn** of the upper limit of **Upper Memory Blocks**, indicating released segments of the BIOS which can be reclaimed by a virtual memory manager.

**Video BIOS shadowed**

Video BIOS successfully copied to shadow RAM.

## Notes

---

## Appendix B BIOS POST Codes

This section lists the POST (Power On Self Test) codes for the PhoenixBIOS. POST codes are divided into two categories: recoverable and terminal.

### Recoverable POST Errors

When a recoverable type of error occurs during POST, the BIOS will display an POST code that describes the problem. BIOS may also issue one of the following beep codes:

- 1 long and two short beeps - video configuration error
- 1 continuous long beep - no memory detected

### Terminal POST Errors

If a terminal type of error occurs, BIOS will shut down the system. Before doing so, BIOS will write the error to port 80h, attempt to initialize video and write the error in the top left corner of the screen.

The following is a list of codes that may be written to port 80h.

<b>POSTCode</b>	<b>Description</b>
02h	Verify Real Mode
03h	Disable Non-Maskable Interrupt (NMI)
04h	Get CPU type
06h	Initialize system hardware
07h	Disable shadow and execute code from the ROM.
08h	Initialize chipset with initial POST values
09h	Set IN POST flag
0Ah	Initialize CPU registers
0Bh	Enable CPU cache
0Ch	Initialize caches to initial POST values
0Eh	Initialize I/O component
0Fh	Initialize the local bus IDE
10h	Initialize Power Management
11h	Load alternate registers with initial POST values
12h	Restore CPU control word during warm boot
13h	Initialize PCI Bus Mastering devices
14h	Initialize keyboard controller
16h	1-2-2-3 BIOS ROM checksum
17h	Initialize cache before memory Auto size

---

<b>POST Code</b>	<b>Description</b>
18h	8254 timer initialization
1Ah	8237 DMA controller initialization
1Ch	Reset Programmable Interrupt Controller
20h	1-3-1-1 Test DRAM refresh
22h	1-3-1-3 Test 8742 Keyboard Controller
24h	Set ES segment register to 4 GB
28h	Auto size DRAM
29h	Initialize POST Memory Manager
2Ah	Clear 512 kB base RAM
2Ch	1-3-4-1 RAM failure on address line <b>xxxx*</b>
2Eh	1-3-4-3 RAM failure on data bits <b>xxxx*</b> of low byte of memory bus
2Fh	Enable cache before system BIOS shadow
32h	Test CPU bus-clock frequency
33h	Initialize Phoenix Dispatch Manager
36h	Warm start shut down
38h	Shadow system BIOS ROM
3Ah	Auto size cache
3Ch	Advanced configuration of chipset registers
3Dh	Load alternate registers with CMOS values
41h	Initialize extended memory for RomPilot
42h	Initialize interrupt vectors
45h	POST device initialization
46h	2-1-2-3 Check ROM copyright notice
47h	Initialize I20 support
48h	Check video configuration against CMOS
49h	Initialize PCI bus and devices
4Ah	Initialize all video adapters in system
4Bh	QuietBoot start (optional)
4Ch	Shadow video BIOS ROM
4Eh	Display BIOS copyright notice
4Fh	Initialize MultiBoot
50h	Display CPU type and speed
51h	Initialize EISA board
52h	Test keyboard
54h	Set key click if enabled
55h	Enable USB devices
58h	2-2-3-1 Test for unexpected interrupts
59h	Initialize POST display service
5Ah	Display prompt "Press F2 to enter SETUP"
5Bh	Disable CPU cache

---

<b>POSTCode</b>	<b>Description</b>
5Ch	Test RAM between 512 and 640 kB
60h	Test extended memory
62h	Test extended memory address lines
64h	Jump to UserPatch1
66h	Configure advanced cache registers
67h	Initialize Multi Processor APIC
68h	Enable external and CPU caches
69h	Setup System Management Mode (SMM) area
6Ah	Display external L2 cache size
6Bh	Load custom defaults (optional)
6Ch	Display shadow-area message
6Eh	Display possible high address for UMB recovery
70h	Display error messages
72h	Check for configuration errors
76h	Check for keyboard errors
7Ch	Set up hardware interrupt vectors
7Dh	Initialize Intelligent System Monitoring
7Eh	Initialize coprocessor if present
80h	Disable onboard Super I/O ports and IRQs
81h	Late POST device initialization
82h	Detect and install external RS232 ports
83h	Configure non-MCD IDE controllers
84h	Detect and install external parallel ports
85h	Initialize PC-compatible PnP ISA devices
86h	Re-initialize onboard I/O ports.
87h	Configure Motherboard Configurable Devices (optional)
88h	Initialize BIOS Data Area
89h	Enable Non-Maskable Interrupts (NMIs)
8Ah	Initialize Extended BIOS Data Area
8Bh	Test and initialize PS/2 mouse
8Ch	Initialize floppy controller
8Fh	Determine number of ATA drives (optional)
90h	Initialize hard-disk controllers
91h	Initialize local-bus hard-disk controllers
92h	Jump to UserPatch2
93h	Build MPTABLE for multi-processor boards
95h	Install CD ROM for boot
96h	Clear huge ES segment register
97h	Fix up Multi Processor table
98h	1-2 Search for option ROMs. One long, two short beeps on checksum failure

---

<b>POST Code</b>	<b>Description</b>
99h	Check for SMART Drive (optional)
9Ah	Shadow option ROMs
9Ch	Set up Power Management
9Dh	Initialize security engine (optional)
9Eh	Enable hardware interrupts
9Fh	Determine number of ATA and SCSI drives
A0h	Set time of day
A2h	Check key lock
A4h	Initialize typematic rate
A8h	Erase F2 prompt
AAh	Scan for F2 key stroke
ACh	Enter SETUP
A Eh	Clear Boot flag
B0h	Check for errors
B1h	Inform RomPilot about the end of POST.
B2h	POST done - prepare to boot operating system
B4h	1 One short beep before boot
B5h	Terminate QuietBoot (optional)
B6h	Check password (optional)
B7h	Initialize ACPI BIOS
B9h	Prepare Boot
BAh	Initialize SMBIOS
BBh	Initialize PnP Option ROMs
BCh	Clear parity checkers
BDh	Display MultiBoot menu
BEh	Clear screen (optional)
BFh	Check virus and backup reminders
C0h	Try to boot with INT 19
C1h	Initialize POST Error Manager (PEM)
C2h	Initialize error logging
C3h	Initialize error display function
C4h	Initialize system error handler
C5h	PnPnd dual CMOS (optional)
C6h	Initialize note dock (optional)
C7h	Initialize note dock late
C8h	Force check (optional)
C9h	Extended checksum (optional)
CAh	Redirect Int 15h to enable remote keyboard
CBh	Redirect Int 13h to Memory Technologies Devices such as ROM, RAM, PCMCIA, and serial disk
CCh	Redirect Int 10h to enable remote serial video

---

<b>POST Code</b>	<b>Description</b>
CDh	Re-map I/O and memory for PCMCIA
CEh	Initialize digitizer and display message
D2h	Unknown interrupt

**The following are for boot block in Flash ROM**

<b>POST Code</b>	<b>Description</b>
E0h	Initialize the chipset
E1h	Initialize the bridge
E2h	Initialize the CPU
E3h	Initialize system timer
E4h	Initialize system I/O
E5h	Check force recovery boot
E6h	Checksum BIOS ROM
E7h	Go to BIOS
E8h	Set Huge Segment
E9h	Initialize Multi Processor
EAh	Initialize OEM special code
EBh	Initialize PIC and DMA
ECh	Initialize Memory type
EDh	Initialize Memory size
EEh	Shadow Boot Block
EFh	System memory test
F0h	Initialize interrupt vectors
F1h	Initialize Run Time Clock
F2h	Initialize video
F3h	Initialize System Management Manager
F4h	Output one beep
F5h	Clear Huge Segment
F6h	Boot to Mini DOS
F7h	Boot to Full DOS

\* If the BIOS detects error 2C, 2E, or 30 (base 512K RAM error), it displays an additional word-bitmap (**xxxx**) indicating the address line or bits that failed. For example, "2C 0002" means address line 1 (bit one set) has failed. "2E 1020" means data bits 12 and 5 (bits 12 and 5 set) have failed in the lower 16 bits. The BIOS also sends the bitmap to the port-80 LED display. It first displays the checkpoint code, followed by a delay, the high-order byte, another delay, and then the low-order byte of the error. It repeats this sequence continuously.

## Notes