



H12SSG-ANP6

USER'S MANUAL

Revision 1.0

The information in this User's Manual has been carefully reviewed and is believed to be accurate. The vendor assumes no responsibility for any inaccuracies that may be contained in this document, and makes no commitment to update or to keep current the information in this manual, or to notify any person or organization of the updates. **Please Note: For the most up-to-date version of this manual, please see our website at www.supermicro.com.**

Super Micro Computer, Inc. ("Supermicro") reserves the right to make changes to the product described in this manual at any time and without notice. This product, including software and documentation, is the property of Supermicro and/or its licensors, and is supplied only under a license. Any use or reproduction of this product is not allowed, except as expressly permitted by the terms of said license.

IN NO EVENT WILL Super Micro Computer, Inc. BE LIABLE FOR DIRECT, INDIRECT, SPECIAL, INCIDENTAL, SPECULATIVE OR CONSEQUENTIAL DAMAGES ARISING FROM THE USE OR INABILITY TO USE THIS PRODUCT OR DOCUMENTATION, EVEN IF ADVISED OF THE POSSIBILITY OF SUCH DAMAGES. IN PARTICULAR, SUPER MICRO COMPUTER, INC. SHALL NOT HAVE LIABILITY FOR ANY HARDWARE, SOFTWARE, OR DATA STORED OR USED WITH THE PRODUCT, INCLUDING THE COSTS OF REPAIRING, REPLACING, INTEGRATING, INSTALLING OR RECOVERING SUCH HARDWARE, SOFTWARE, OR DATA.

Any disputes arising between manufacturer and customer shall be governed by the laws of Santa Clara County in the State of California, USA. The State of California, County of Santa Clara shall be the exclusive venue for the resolution of any such disputes. Supermicro's total liability for all claims will not exceed the price paid for the hardware product.

FCC Statement: This equipment has been tested and found to comply with the limits for a Class A or Class B digital device pursuant to Part 15 of the FCC Rules. These limits are designed to provide reasonable protection against harmful interference when the equipment is operated in industrial environment for Class A device or in residential environment for Class B device. This equipment generates, uses, and can radiate radio frequency energy and, if not installed and used in accordance with the manufacturer's instruction manual, may cause harmful interference with radio communications. Operation of this equipment in a residential area is likely to cause harmful interference, in which case you will be required to correct the interference at your own expense.

California Best Management Practices Regulations for Perchlorate Materials: This Perchlorate warning applies only to products containing CR (Manganese Dioxide) Lithium coin cells. "Perchlorate Material-special handling may apply. See www.dtsc.ca.gov/hazardouswaste/perchlorate".



WARNING: This product can expose you to chemicals including lead, known to the State of California to cause cancer and birth defects or other reproductive harm. For more information, go to www.P65Warnings.ca.gov.

The products sold by Supermicro are not intended for and will not be used in life support systems, medical equipment, nuclear facilities or systems, aircraft, aircraft devices, aircraft/emergency communication devices or other critical systems whose failure to perform be reasonably expected to result in significant injury or loss of life or catastrophic property damage. Accordingly, Supermicro disclaims any and all liability, and should buyer use or sell such products for use in such ultra-hazardous applications, it does so entirely at its own risk. Furthermore, buyer agrees to fully indemnify, defend and hold Supermicro harmless for and against any and all claims, demands, actions, litigation, and proceedings of any kind arising out of or related to such ultra-hazardous use or sale.

Manual Revision 1.0

Release Date: November 15, 2022

Unless you request and receive written permission from Super Micro Computer, Inc., you may not copy any part of this document. Information in this document is subject to change without notice. Other products and companies referred to herein are trademarks or registered trademarks of their respective companies or mark holders.

Copyright © 2022 by Super Micro Computer, Inc.

All rights reserved.

Printed in the United States of America

Preface

About This Manual

This manual is written for system integrators, IT technicians and knowledgeable end users. It provides information for the installation and use of the H12SSG-ANP6 motherboard.

About This Motherboard

Built upon the functionality and capability of the AMD Ryzen™ Threadripper™ PRO 3000/5000 processor, the H12SSG-ANP6 motherboard provides high performance for multi-threaded workloads while consuming little power. Please note that this motherboard is intended to be installed and serviced by professional technicians only. For processor/memory updates, please refer to our website at <http://www.supermicro.com/products/>.

Conventions Used in the Manual

Special attention should be given to the following symbols for proper installation and to prevent damage done to the components or injury to yourself:



Warning! Indicates important information given to prevent equipment/property damage or personal injury.



Warning! Indicates high voltage may be encountered when performing a procedure.

Contacting Supermicro

Headquarters

Address: Super Micro Computer, Inc.
980 Rock Ave.
San Jose, CA 95131 U.S.A.

Tel: +1 (408) 503-8000

Fax: +1 (408) 503-8008

Email: marketing@supermicro.com (General Information)
Sales-USA@supermicro.com (Sales Inquiries)
Government_Sales-USA@supermicro.com (Gov. Sales Inquiries)
support@supermicro.com (Technical Support)
RMA@supermicro.com (RMA Support)
Webmaster@supermicro.com (Webmaster)

Website: www.supermicro.com

Europe

Address: Super Micro Computer B.V.
Het Sterrenbeeld 28, 5215 ML
's-Hertogenbosch, The Netherlands

Tel: +31 (0) 73-6400390

Fax: +31 (0) 73-6416525

Email: Sales_Europe@supermicro.com (Sales Inquiries)
Support_Europe@supermicro.com (Technical Support)
RMA_Europe@supermicro.com (RMA Support)

Website: www.supermicro.nl

Asia-Pacific

Address: Super Micro Computer, Inc.
3F, No. 150, Jian 1st Rd.
Zhonghe Dist., New Taipei City 235
Taiwan (R.O.C)

Tel: +886-(2) 8226-3990

Fax: +886-(2) 8226-3992

Email: Sales-Asia@supermicro.com.tw (Sales Inquiries)
Support@supermicro.com.tw (Technical Support)
RMA@supermicro.com.tw (RMA Support)

Website: www.supermicro.com.tw

Table of Contents

Chapter 1 Introduction

1.1 Quick Reference.....	10
Quick Reference Table.....	11
Motherboard Features.....	12
Motherboard Block Diagram	14
1.2 Processor Overview	15
1.3 Special Features	15
Recovery from AC Power Loss.....	15
1.4 System Health Monitoring	15
Onboard Voltage Monitors	15
Fan Status Monitor with Firmware Control	16
Environmental Temperature Control	16
System Resource Alert.....	16
1.5 ACPI Features.....	16
1.6 Power Supply	17
1.7 Super I/O	17

Chapter 2 Installation

2.1 Static-Sensitive Devices.....	18
Precautions	18
Unpacking	18
2.2 Motherboard Installation.....	19
Location of Mounting Holes	19
Installing the Motherboard.....	21
2.3 Processor and Heatsink Installation.....	22
2.4 Memory Support and Installation	28
Memory Support.....	28
DIMM Module Population.....	30
DIMM Installation	31
DIMM Removal	31
2.5 Rear I/O Ports	32
2.6 Connectors	34

2.7 Jumper Settings	37
How Jumpers Work.....	37
2.8 LED Indicators.....	39
Chapter 3 Troubleshooting	
3.1 Troubleshooting Procedures	41
Before Power On	41
No Power	41
No Video	42
System Boot Failure.....	42
Memory Errors	42
The System Can't Retain the Setup Configuration.....	42
When the System Becomes Unstable	43
3.2 Technical Support Procedures	44
3.3 Frequently Asked Questions	45
3.4 Returning Merchandise for Service.....	46
3.5 Battery Removal and Installation	46
Battery Removal.....	46
Proper Battery Disposal	47
Battery Installation.....	47
Chapter 4 BIOS (Threadripper PRO 3000)	
4.1 Introduction.....	48
Starting the Setup Utility	48
4.2 Main Setup	49
4.3 Advanced.....	51
4.4 IPMI	69
4.5 Event Logs	72
4.6 Security.....	74
4.7 Boot	77
4.8 Save & Exit.....	80
Chapter 5 BIOS (Threadripper PRO 5000)	
5.1 Introduction.....	82
Starting the Setup Utility	82
5.2 Main Setup	83

5.3 Advanced.....	85
5.4 IPMI	102
5.5 Event Logs	105
5.6 Security.....	107
5.7 Boot	110
5.8 Save & Exit.....	113
Appendix A Software	
A.1 Microsoft Windows OS Installation.....	115
A.2 Driver Installation.....	117
A.3 SuperDoctor® 5.....	118
A.4 IPMI	118
Appendix B Standardized Warning Statements	
B.1 Battery Handling	119
B.2 Product Disposal.....	121
Appendix C UEFI BIOS Recovery	
C.1 Overview.....	122
C.2 Recovering the UEFI BIOS Image	122
C.3 Recovering the BIOS Block with a USB Device	122

Chapter 1

Introduction

Congratulations on purchasing your computer motherboard from an industry leader. Supermicro boards are designed to provide you with the highest standards in quality and performance.

In addition to the motherboard, several important parts that are included with the system are listed below. If anything listed is damaged or missing, please contact your retailer.

Important Links

For your system to work properly, please follow the links below to download all necessary drivers/utilities and the user's manual for your server.

- Supermicro product manuals: <https://www.supermicro.com/support/manuals/>
- Product drivers and utilities: <https://www.supermicro.com/wdl/driver>
- Product safety info: https://www.supermicro.com/about/policies/safety_information.cfm
- If you have any questions, please contact our support team at: support@supermicro.com

This manual may be periodically updated without notice. Please check the Supermicro website for possible updates to the manual revision level.

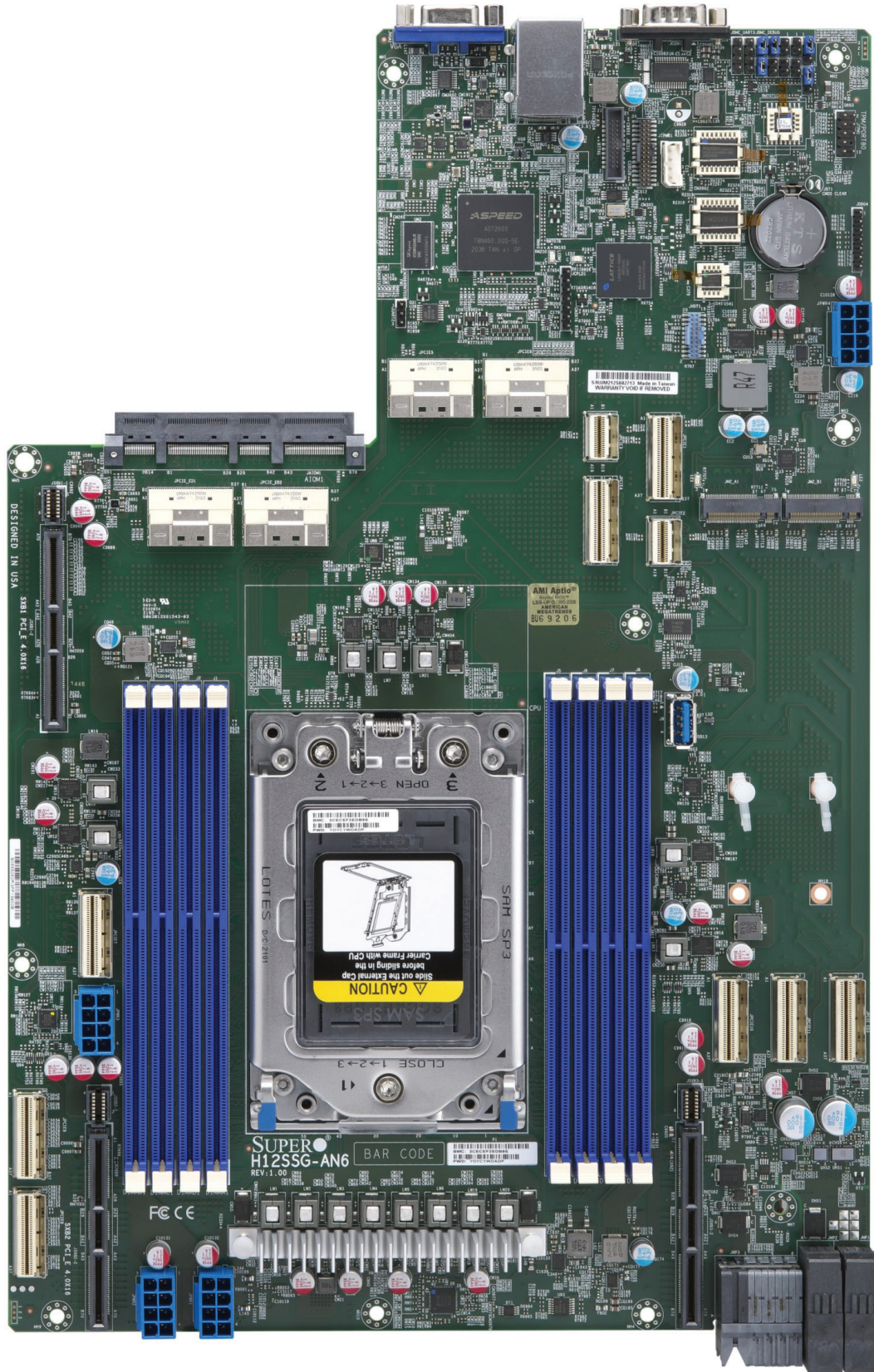

Figure 1-1. H12SSG-ANP6 Image

1.1 Quick Reference

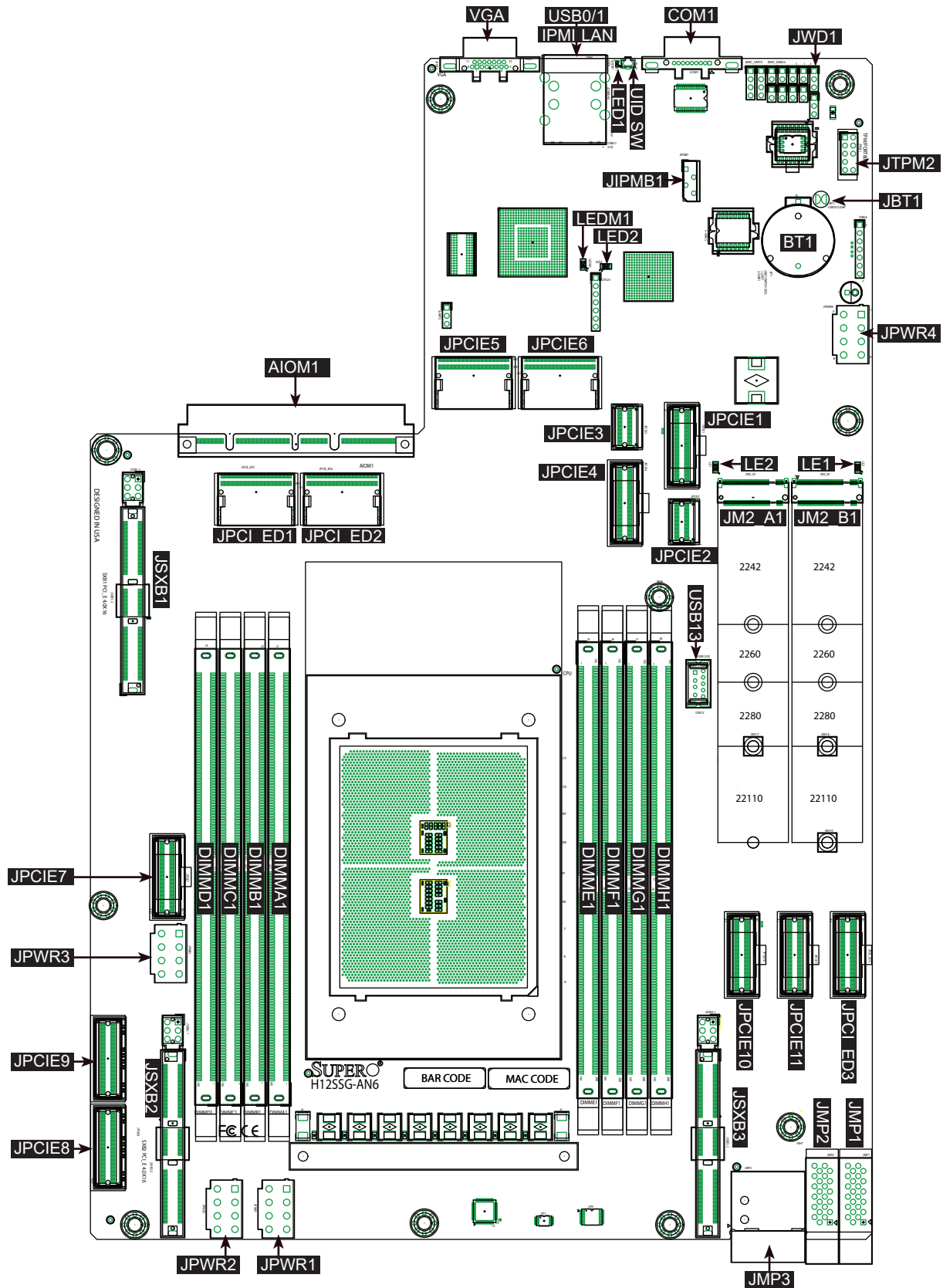

Figure 1-2. H12SSG-ANP6 Layout

Quick Reference Table

Jumper	Description	Default Setting
JBT1	Clear CMOS	Open (Normal)
JWD1	Watch Dog control	Pins 1-2 (Reset)

LED	Description	Status
LE1	M.2-B1 Active LED	On: Activity on M.2-B1 device
LE2	M.2-A1 Active LED	On: Activity on M.2-A1 device
LED1	UID LED	Solid Blue: UID Activated
LED2	Power LED	On: Power On
LEDM1	BMC Heartbeat	Blinking: BMC Normal/Working

Connector	Description
AIOM1	Advanced I/O Module (AIOM) networking slot
Battery (BT1)	Onboard CMOS battery
COM1	Rear panel COM port #1
IPMI LAN	RJ45 dedicated IPMI LAN port
JIPMB1	BMC external I ² C header
JM2_A1/JM2_B1	M.2 device slots
JMP1/2/3	Connector for SCC-P2N2FG-P1A-B or SCC-P2N2FG-P1A-A
JPC_ED1/ED2/ED3	PCIe 4.0 x8 SlimSAS connectors
JPCIE1, JPCIE4-11	PCIe 4.0 x8 SlimSAS connectors
JPCIE2, JPCIE3	PCIe 4.0 x4 SlimSAS connectors
JSXB1	PCIe 4.0 x16 slot
JSXB2	PCIe 4.0 x16 slot
JSXB3	PCIe 4.0 x16 slot
JPWR1-4	GPU 12V 8-pin power connector
JTPM2	Trusted Platform Module (TPM)/Port 80 connector
UID_SW	UID switch (push-button to toggle UID on/off)
USB0/1	Rear USB 3.1 ports
USB13	Internal USB 2.0 header
VGA	VGA port

Notes:

See Chapter 2 for detailed information on jumpers, I/O ports, and JF1 front panel connections. Jumpers/LED indicators not indicated are used for testing purposes only.

Motherboard Features

Features

CPU

- Single AMD Ryzen™ Threadripper™ PRO 3000/5000 Series, in one SP3 socket

Memory

- Up to 2TB registered ECC DDR4 up to 3200MHz in eight DIMM slots

DIMM Size

- Up to 256GB size at 1.2V

Chipset

- System on Chip

Expansion Slots

- Three PCIe 4.0 x16 riser slots
- One AIOM (PCIe 4.0 x16) networking slot
- Nine PCIe 4.0 x8 SlimSAS connectors
- Two PCIe 4.0 x4 SlimSAS connectors

Network

- One Realtek RTL8211E PHY (dedicated IPMI)

Storage Ports

- Two M.2 PCIe 4.0 x4 slots (2242, 2260, 2280, and 22110 form factor)

Graphics

- ASPEED AST2600 BMC chip with one VGA port

I/O Devices

- One COM port
- One VGA port
- Two USB 3.1 ports

BIOS

- 256Mb SPI AMI BIOS®
- ACPI 6.2, SMBIOS 3.1.1, Plug-and-Play (PnP), BIOS rescue hot-key, RTC (Real Time Clock) wake up, Riser Card Auto-Detection Support

Power Management

- ACPI power management (S5)
- Power button override mechanism
- Power-on mode for AC power recovery

System Health Monitoring

Note: The table above continues on the next page.

Features

- Onboard voltage monitoring for +1.8V, 3.3V, +5V, +12V, +3.3V Standby, +5V Standby, VBAT, HT, Memory
- Onboard monitoring for CPU, system, and memory temperature
- CPU switching phase voltage regulator
- CPU Thermal Trip support

Fan Control

- One cooling zone
- Low-noise fan speed control
- Pulse Width Modulation (PWM) fan control

System Management

- Trusted Platform Module (TPM) support
- System resource alert via SuperDoctor® 5
- SuperDoctor® 5, Watch Dog
- Non-Maskable Interrupt (NMI)

LED Indicators

- Power State Indicator
- CPU/Overheating
- Fan Failure
- LAN activity
- UID / Remote UID

Dimensions

- 9" x 15" (W x L), 228.6 x 381 mm

Motherboard Block Diagram

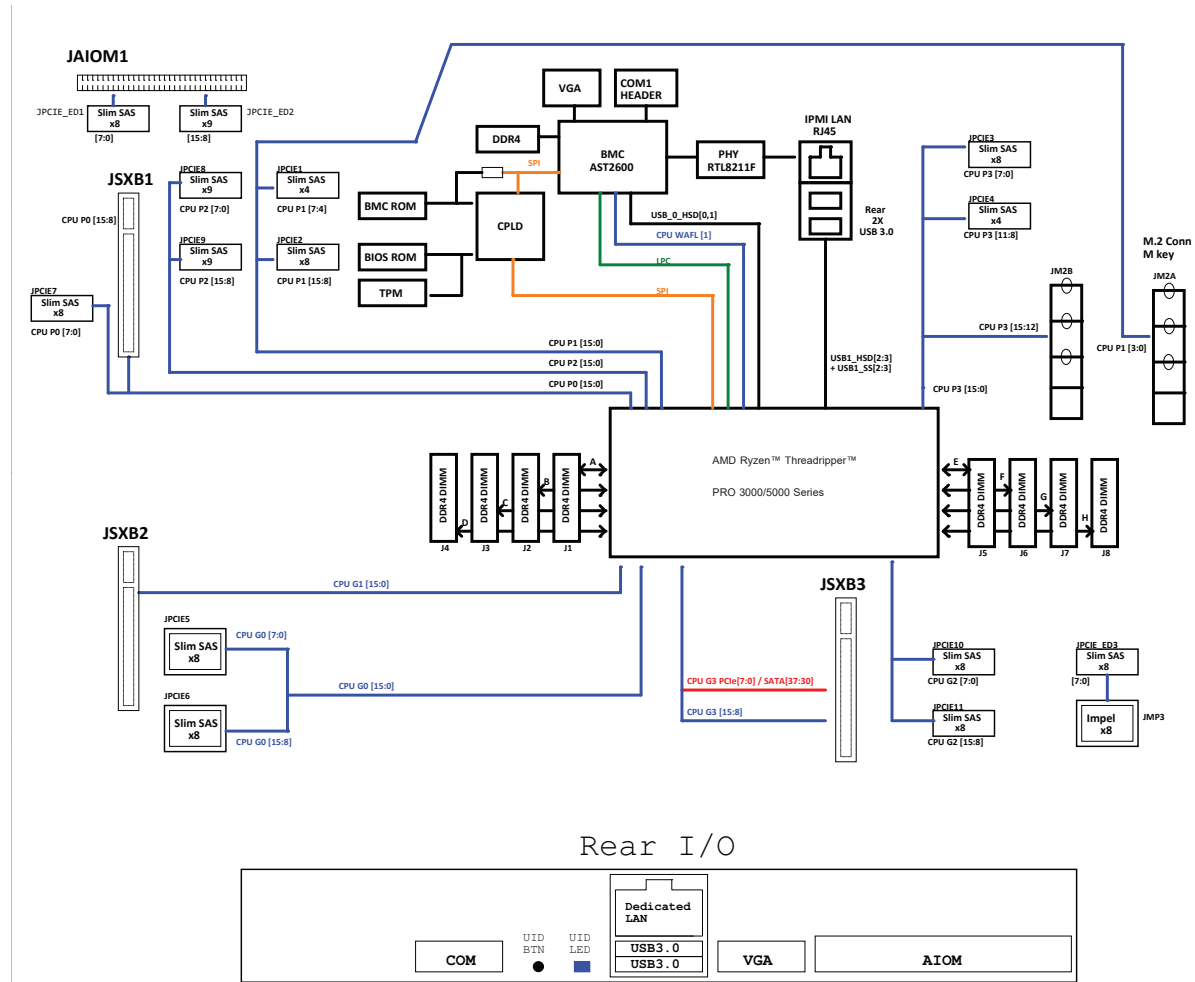

Figure 1-3. Motherboard Block Diagram

Note: This is a general block diagram and may not exactly represent the features on your motherboard. See the previous pages for the actual specifications of your motherboard.

1.2 Processor Overview

The H12SSG-ANP6 motherboard offers maximum I/O expandability, energy efficiency, and data reliability. It is optimized for graphics-intensive desktop or workstation solutions.

The AMD Ryzen™ Threadripper™ PRO 3000/5000 Series supports the following features:

- Leading single threaded and multithreaded performance
- AMD PRO Technologies
- Unrivaled memory bandwidth
- PCIe® 4.0 support for next-gen GPUs and storage
- BMC supports remote management, virtualization, and the security package for enterprise platforms.

1.3 Special Features

This section describes the health monitoring features of the H12SSG-ANP6. The motherboard has an onboard System Hardware Monitor chip that supports system health monitoring.

Recovery from AC Power Loss

The Basic I/O System (BIOS) provides a setting that determines how the system will respond when AC power is lost and then restored to the system. You can choose for the system to remain powered off (in which case you must press the power switch to turn it back on), or for it to automatically return to the power-on state. See the Advanced BIOS Setup section for this setting. The default setting is Last State.

1.4 System Health Monitoring

This section describes the health monitoring features of the H12SSG-ANP6 motherboard. The motherboard has an onboard Baseboard Management Controller (BMC) chip that supports system health monitoring. Once a voltage becomes unstable, a warning is given or an error message is sent to the screen. The user can adjust the voltage thresholds to define the sensitivity of the voltage monitor.

Onboard Voltage Monitors

The onboard voltage monitor will continuously scan crucial voltage levels. Once a voltage becomes unstable, it will give a warning or send an error message to the screen. Users can

adjust the voltage thresholds to define the sensitivity of the voltage monitor. Real time readings of these voltage levels are all displayed in BMC.

Fan Status Monitor with Firmware Control

Users can check the RPM status of the cooling fans through the IPMI Web interface. The chassis fans are controlled by Thermal Management.

Environmental Temperature Control

The thermal control sensor monitors the CPU temperature in real time and will turn on the thermal control fan whenever the CPU temperature exceeds a user-defined threshold. The overheat circuitry runs independently from the CPU. Once the thermal sensor detects that the CPU temperature is too high, it will automatically turn on the thermal fans to prevent the CPU from overheating. The onboard chassis thermal circuitry can monitor the overall system temperature and alert the user when the chassis temperature is too high.

Note: To avoid possible system overheating, please be sure to provide adequate airflow to your system.

System Resource Alert

This feature is available when used with SuperDoctor 5[®]. SuperDoctor 5 is used to notify the user of certain system events. For example, you can configure SuperDoctor 5 to provide you with warnings when the system temperature, CPU temperatures, voltages and fan speeds go beyond a predefined range.

1.5 ACPI Features

ACPI stands for Advanced Configuration and Power Interface. The ACPI specification defines a flexible and abstract hardware interface that provides a standard way to integrate power management features throughout a computer system including its hardware, operating system and application software. This enables the system to automatically turn on and off peripherals such as network cards, hard disk drives and printers.

In addition to enabling operating system-directed power management, ACPI also provides a generic system event mechanism for Plug and Play and an operating system-independent interface for configuration control. ACPI leverages the Plug and Play BIOS data structures while providing a processor architecture-independent implementation that is compatible with Windows Server 2019 operating systems.

1.6 Power Supply

As with all computer products, a stable power source is necessary for proper and reliable operation. It is even more important for processors that have high CPU clock rates. In areas where noisy power transmission is present, you may choose to install a line filter to shield the computer from noise. It is recommended that you also install a power surge protector to help avoid problems caused by power surges.

1.7 Super I/O

The ASpeed AST2600 Super I/O provides one high-speed, 16550 compatible Universal Asynchronous Receiver/Transmitter (UART), which support serial infrared communications. This UART includes a send/receive FIFO, a programmable baud rate generator, complete modem control capability and a processor interrupt system. This UART provides legacy speed with baud rate of up to 115.2 Kbps as well as an advanced speed with baud rates of 250 K, 500 K, or 1 Mb/s, which support higher speed modems.

The Super I/O provides functions that comply with ACPI (Advanced Configuration and Power Interface), which includes support of legacy and ACPI power management through the System Management Interrupt (SMI) or System Control Interrupt (SCI). It also features auto power management to reduce power consumption.

Chapter 2

Installation

2.1 Static-Sensitive Devices

Electrostatic Discharge (ESD) can damage electronic components. To prevent damage to your motherboard, it is important to handle it very carefully. The following measures are generally sufficient to protect your equipment from ESD.

Precautions

- Use a grounded wrist strap designed to prevent static discharge.
- Touch a grounded metal object before removing the board from the antistatic bag.
- Handle the board by its edges only; do not touch its components, peripheral chips, memory modules or gold contacts.
- When handling chips or modules, avoid touching their pins.
- Put the motherboard and peripherals back into their antistatic bags when not in use.
- For grounding purposes, make sure that your chassis provides excellent conductivity between the power supply, the case, the mounting fasteners and the motherboard.
- Use only the correct type of CMOS onboard battery as specified by the manufacturer. Do not install the CMOS battery upside down, which may result in a possible explosion.

Unpacking

The motherboard is shipped in antistatic packaging to avoid static damage. When unpacking the motherboard, make sure that the person handling it is static protected.

2.2 Motherboard Installation

All motherboards have standard mounting holes to fit different types of chassis. Make sure that the locations of all the mounting holes for both the motherboard and the chassis match. Although a chassis may have both plastic and metal mounting fasteners, metal ones are highly recommended because they ground the motherboard to the chassis. Make sure that the metal standoffs click in or are screwed in tightly.



**Phillips
Screwdriver (1)**



Phillips Screws



**Standoffs (11)
Only if Needed**

Tools Needed

Location of Mounting Holes

Notes:

1. To avoid damaging the motherboard and its components, please do not use a force greater than 8 lb/inch on each mounting screw during motherboard installation.
2. Some components are very close to the mounting holes. Please take precautionary measures to avoid damaging these components when installing the motherboard to the chassis.

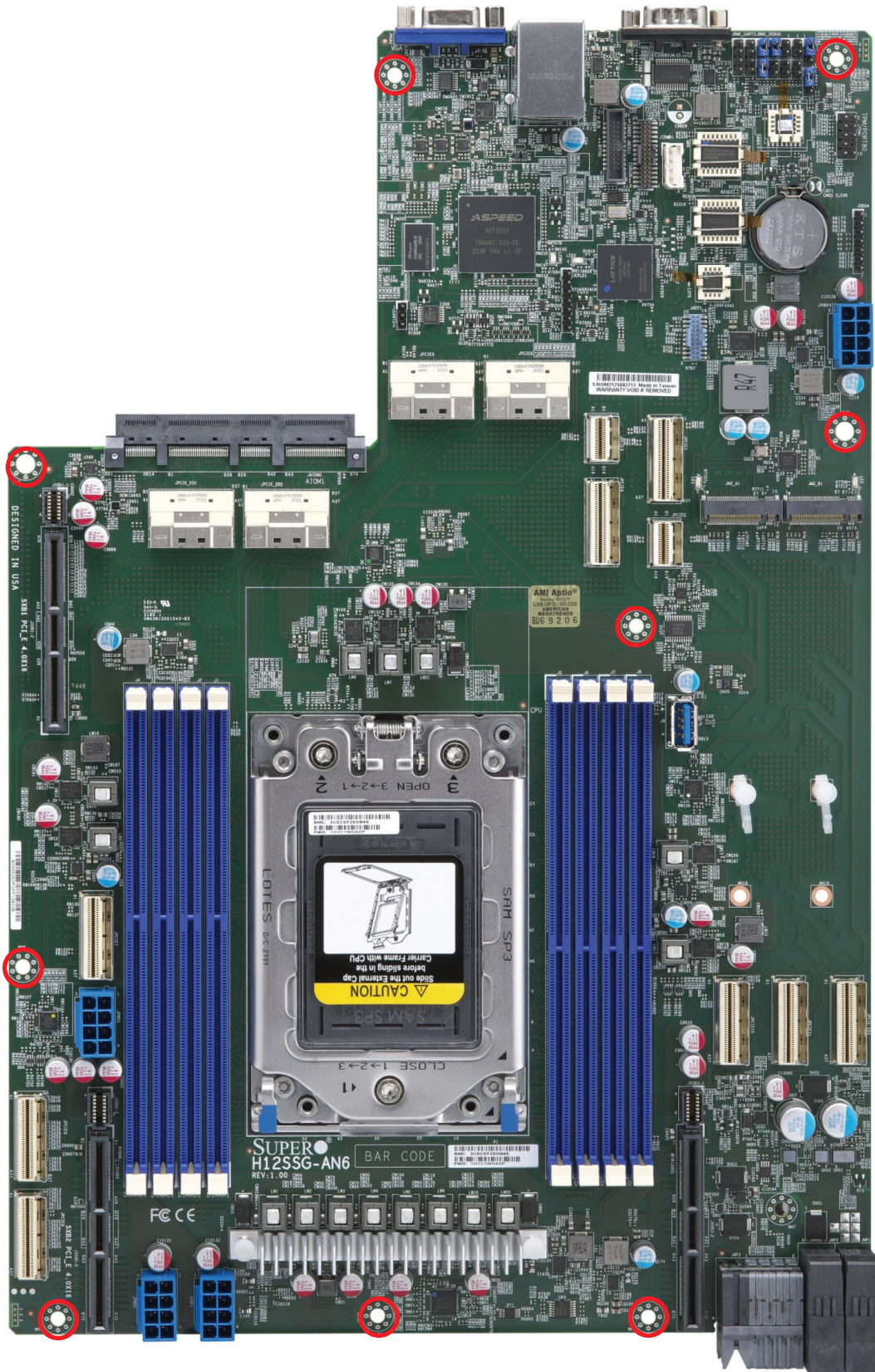
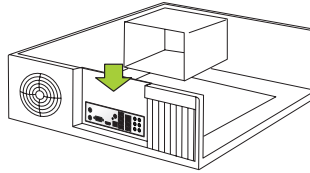

Figure 2-1. Motherboard Mounting Holes

Installing the Motherboard

1. Install the I/O shield into the back of the chassis.



2. Locate the mounting holes on the motherboard. See the previous page for the locations.

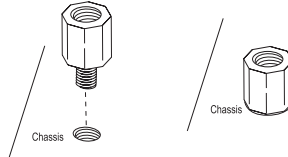

3. Locate the matching mounting holes on the chassis. Align the mounting holes on the motherboard with the mounting holes on the chassis.

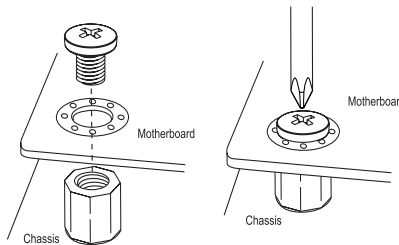

4. Install standoffs in the chassis as needed.
5. Install the motherboard into the chassis carefully to avoid damaging other motherboard components.
6. Using the Phillips screwdriver, insert a Phillips head #6 screw into a mounting hole on the motherboard and its matching mounting hole on the chassis.
7. Repeat Step 5 to insert #6 screws into all mounting holes.
8. Make sure that the motherboard is securely placed in the chassis.

Note: Images displayed are for illustration only. Your chassis or components might look different from those shown in this manual.

2.3 Processor and Heatsink Installation

Warning: When handling the processor package, avoid placing direct pressure on the label area of the fan.

Important:

- For the Processor/Heatsink installation you need to use a T20 screwdriver when opening/closing the CPU socket.
- Always connect the power cord last, and always remove it before adding, removing or changing any hardware components. Make sure that you install the processor into the CPU socket before you install the CPU heatsink.
- If you buy a CPU separately, make sure that you use an AMD-certified heatsink only. Make sure to install the motherboard into the chassis before you install the CPU heatsink.
- When receiving a motherboard without a processor pre-installed, make sure that the plastic CPU socket cap is in place and none of the socket pins are bent; otherwise, contact your retailer immediately.
- Refer to the Supermicro website for updates on CPU support.

Installing the Processor and Heatsink

1. Unscrew the screws holding down Force Frame in the sequence of 3-2-1. The screws are numbered on the force frame next to each screw hole.

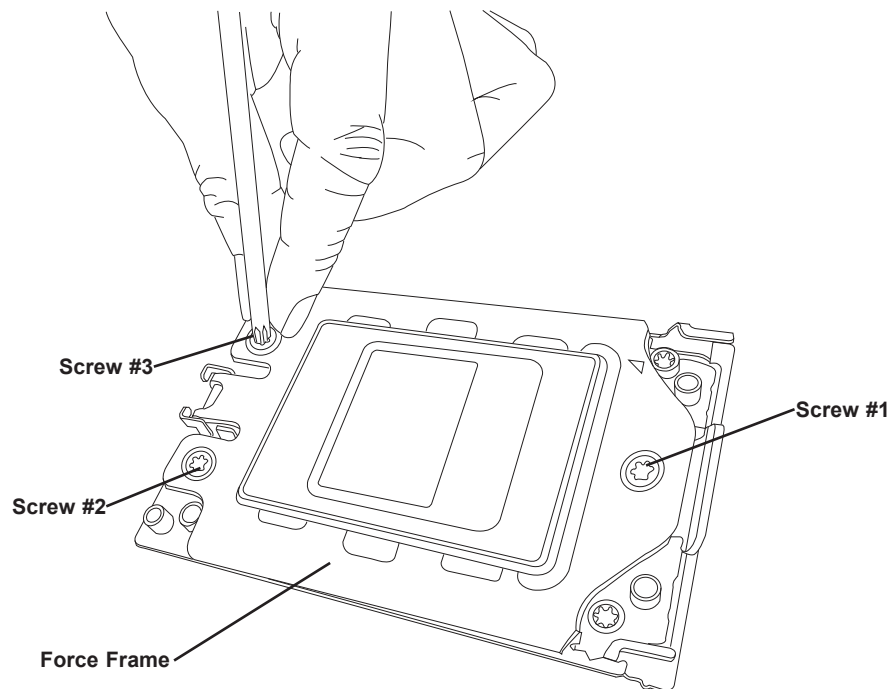

2. The spring-loaded force frame will raise up after the last screw securing it (#1) is removed. Gently allow it to lift up to its stopping position.

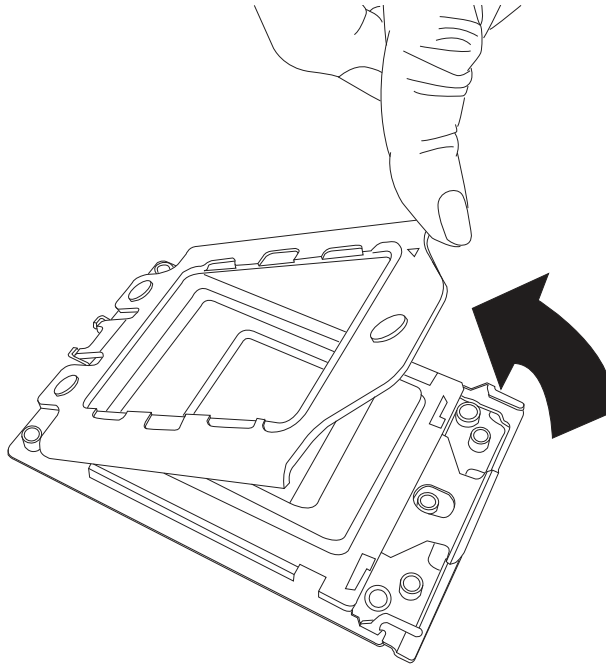

3. Lift the rail frame up by gripping the lift tabs near the front end of the rail frame. While keeping a secure grip of the rail frame, lift it to a position so you can do the next step of removing the external cap.

Note: The rail frame is spring loaded, so keep a secure grip on it as you lift it so it does not snap up.

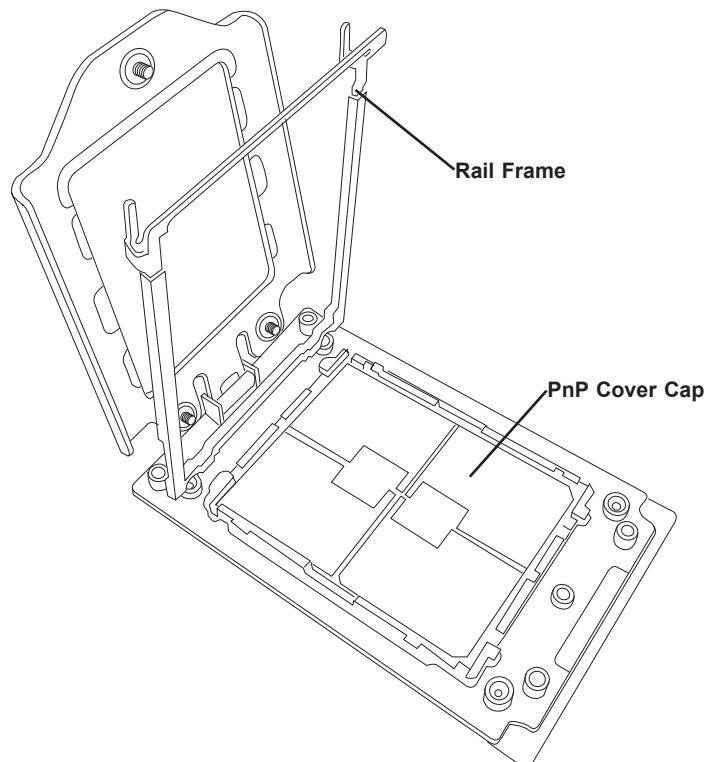

4. Remove the external cap from the Rail Frame by pulling it upwards through the rail guides on the rail frame.

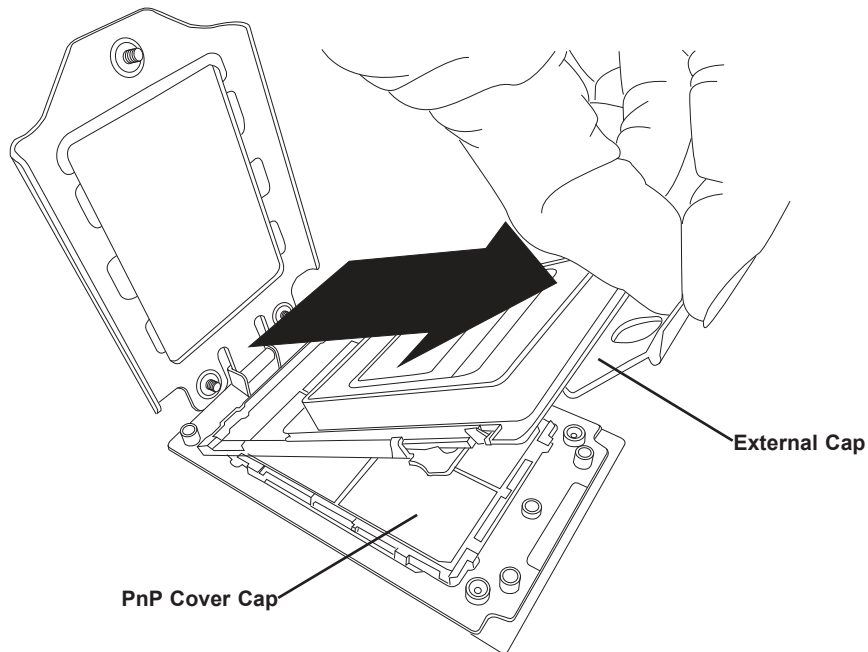

5. The CPU package is shipped from the factory with the blue carrier frame pre-assembled. Grip the handle of the carrier frame/CPU package assembly from its shipping tray, and while gripping the handle, align the flanges of the carrier frame onto the rails of the rail frame so its pins will be at the bottom when the rail frame is lowered later.
6. Slide the carrier frame/CPU package downwards to the bottom of the rail frame. Ensure the flanges are secure on the rails as you lower it downwards.

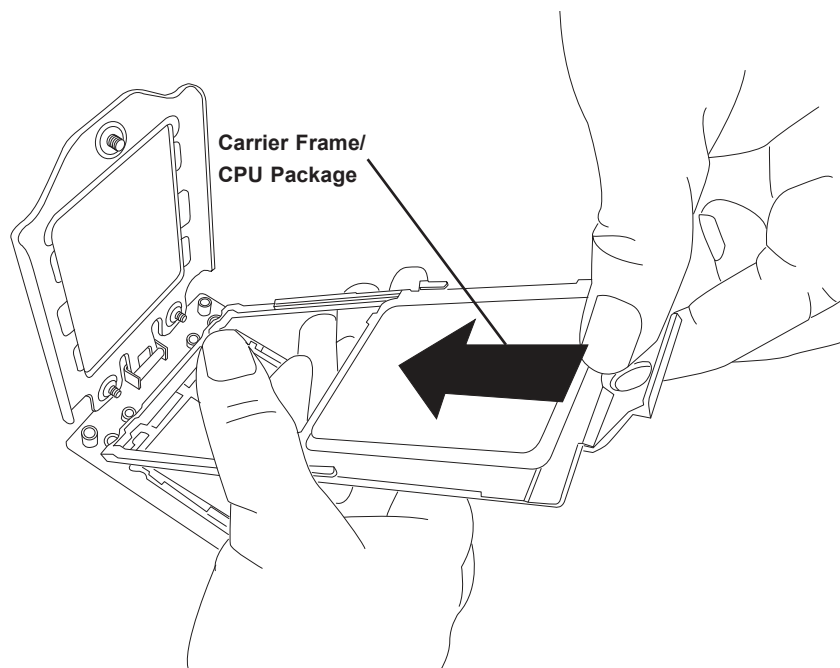

Note: You can only install the CPU inside the socket in one direction with the handle at the top. Make sure that it is properly inserted into the CPU socket before closing the rail frame plate. If it doesn't close properly, do not force it as it may damage your CPU. Instead, open the rail frame plate again, and double-check that the CPU is aligned properly.

7. Lift up the rail frame till it securely rests in upright position. Then remove the PnP cover cap from the CPU socket below. Grip the two lift tabs marked "Remove" at the middle of the cap and pull vertically upwards to remove the PnP cover cap.

Warning! The exposed socket contacts are extremely vulnerable and can be damaged easily. Do not touch or drop objects onto the contacts and be careful removing the PnP cover cap and when placing the rail frame over the socket.

8. Gently lower the rail frame down onto the socket until the latches on the rail frame engage with the socket housing and it rests in place. **DO NOT** force it into place!

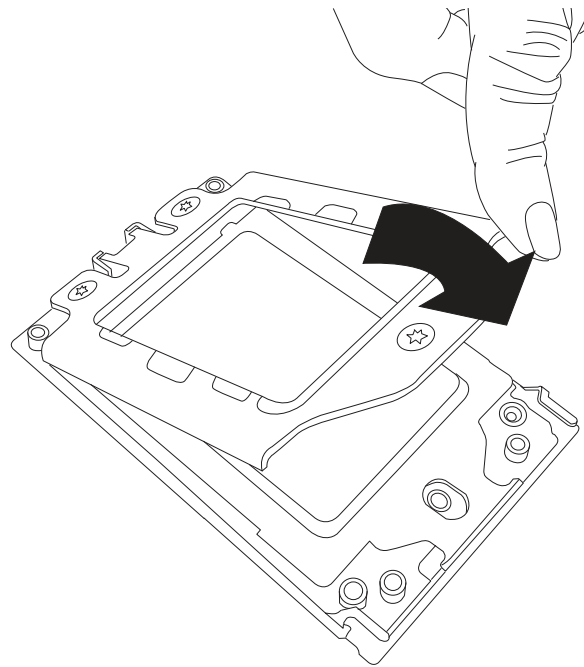

9. Gently lower the force frame down onto the rail frame and hold it in place until it is seated in the Socket housing. Note that the force frame is spring loaded and has to be held in place before it is secured. **Important: Use a torque screwdriver, set it at 16.1 kgf-cm (14.0 lbf-in) with a Torx T20 screw head bit, to prevent damage to the CPU.**

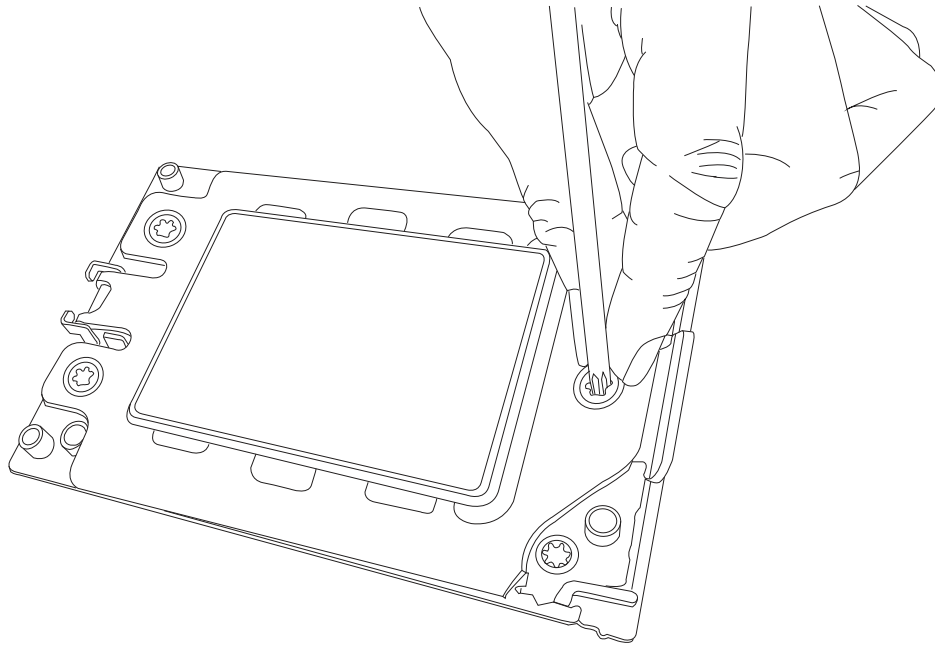

10. Place and re-screw the screws in the reverse order to the way you removed them (holes 1-2-3 in order). When finished, the force frame will be secure over both the rail frame and CPU package.

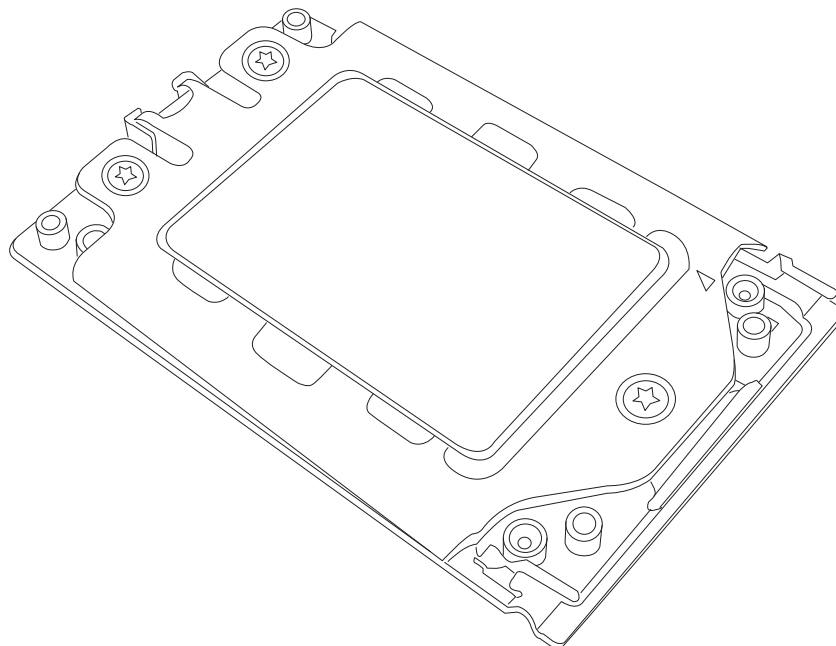

11. After the force frame is secured and the CPU package is in place, now you must install the heatsink to the frame. Lower the heatsink down till it rests securely over the four screw holes on CPU package on the socket frame.

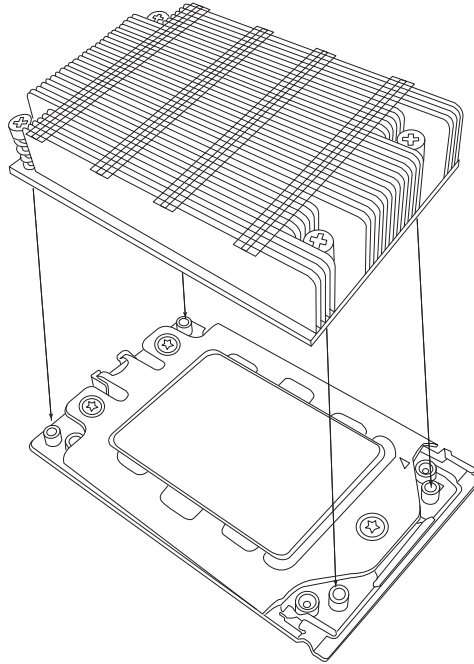

12. Using a diagonal pattern, tighten the four screws down on the heatsink in a clockwise fashion till it is secure. The heatsink will now be secured and you have finished installing the processor and heatsink onto the motherboard. Repeat this procedure for any remaining CPU sockets on the motherboard.

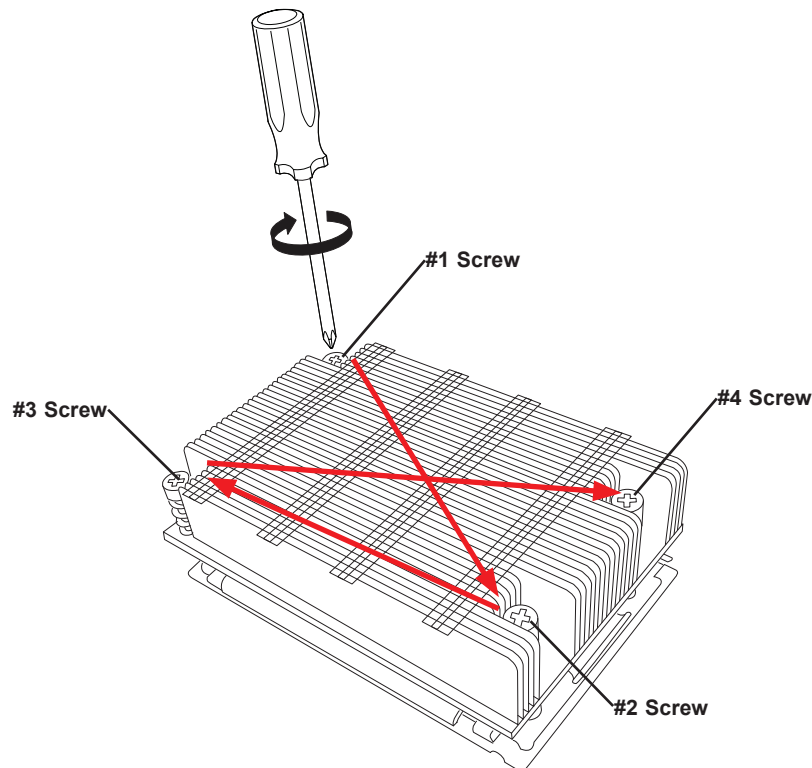

Un-installing the Processor and Heatsink

1. Remove the heatsink attached to the top of the CPU package by reversing the installation procedure.
2. Clean the Thermal grease left by the heatsink on the CPU package lid to limit the risk of it contaminating the CPU package land pads or contacts in the socket housing.
3. Reverse the procedure for installing the force frame onto the socket, unscrewing the plate in the 3-2-1 screw order and lift the force frame to the vertical position.
4. Lift the rail frame using the lift tabs near the front end of the rail frame. Note that the rail frame is spring loaded, so be careful lifting it up into a vertical position.
5. Grip the handle of the carrier frame and pull upwards to extract it from the rail frame. Return the carrier frame/CPU package to its original shipping container.
6. Grip the handle on the external cap and return it to the rail frame sliding it downwards till it rests in the frame.
7. Gripping the rail frame, rotate it downwards till it rests above and locks over the socket housing in its horizontal position.
8. Push and rotate down the force frame till it is over the external cap and rail frame into a horizontal position.
9. While holding down the force frame, secure it back to the socket frame by securing screw 1 in place. Note that without a CPU package in place, it is not necessary to tighten down screws 2 and 3 at this time.

2.4 Memory Support and Installation

Note: Check the Supermicro website for recommended memory modules.

Important: Exercise extreme care when installing or removing DIMM modules to prevent any possible damage.

Memory Support

The H12SSG-ANP6 supports up to 4TB of ECC DDR4 3200 MHz speed, SDRAM memory in eight slots. Refer to the table below for additional memory information.

Notes: Check the Supermicro website for possible updates to memory support.

Populating RDIMM/RDIMM 3DS/LRDIMM/LRDIMM 3DS DDR4 Memory Modules				
Type	DIMM Population	Maximum DIMM Capacity (GB)		Maximum Frequency (MHz)
		1 Channel	8 Channels	
RDIMM	1R (1 Rank)	32GB	256GB	3200
	2R or 2DR (2 Ranks)	64GB	512GB	3200
LRDIMM dual die	4DR (4 Ranks)	128GB	1TB	3200
3DS LRDIMM	2S2R (4 Ranks)	128GB	1TB	3200
	2S4R (8 Ranks)	256GB	2TB	3200
3DS RDIMM	2S2R (4 Ranks)	128GB	1TB	3200
	2S4R (8 Ranks)	256GB	2TB	3200

1R: 1 package rank of SDP DRAMs

2R: 2 package rank of SDP DRAMs

2DR: 2 package rank of DDP DRAMs

4DR: 4 package rank of DDP DRAMs

2S2R/2S4R/2S8R: 2 package rank of 2/4/8 high 3DS DRAMs

DIMM Population Guide (with AMD Ryzen™ Threadripper™)								
Channel								
CPU#	D1	C1	B1	A1	E1	F1	G1	H1
1 DIMM (supported but not recommended)								
CPU1		X						
2 DIMMs (supported but not recommended)								
CPU1	X	X						
4 DIMMs (conditionally recommended if 32 cores or fewer)								
CPU1	X	X					X	X
6 DIMMs								
Unbalanced (Not Recommended)								
8 DIMMs								
CPU1	X	X	X	X	X	X	X	X

DIMM Module Population

There is no specific order or sequence required when installing memory modules. However do keep the following in mind:

- Mixed DIMM speeds can be installed. However, all DIMMs will run at the speed of the slowest DIMM.
- The motherboard will support odd-numbered modules (1 or 3 modules installed). However, to achieve the best memory performance, a balanced memory population is recommended.

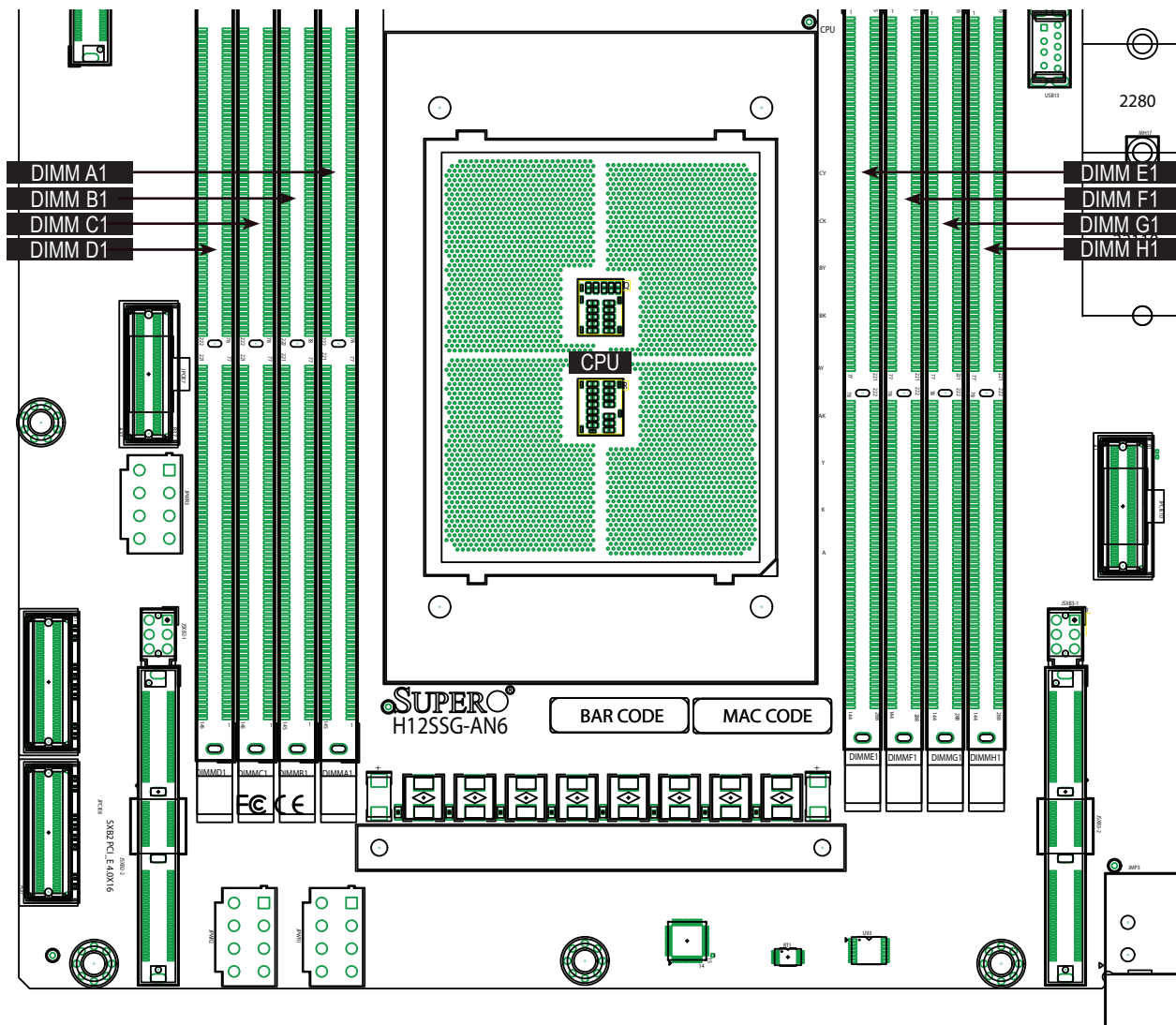

DIMM Installation

1. Insert the desired number of DIMMs into the memory slots, there is no specific sequence or order required.
2. Push the release tabs outwards on both ends of the DIMM slot to unlock it.
3. Align the key of the DIMM module with the receptive point on the memory slot.
4. Align the notches on both ends of the module against the receptive points on the ends of the slot.
5. Press both ends of the module straight down into the slot until the module snaps into place.
6. Press the release tabs to the lock positions to secure the DIMM module into the slot.

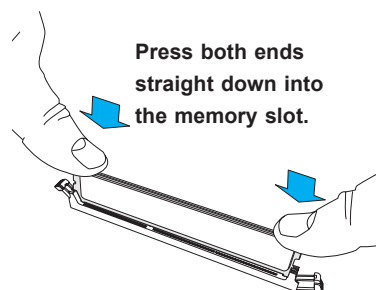
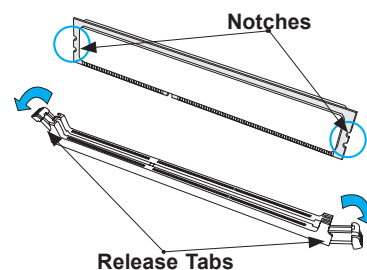
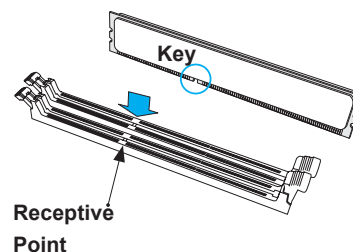

DIMM Removal

Press both release tabs on the ends of the DIMM module to unlock it. Once the DIMM module is loosened, remove it from the memory slot.

2.5 Rear I/O Ports

See Figure 2-1 below for the locations and descriptions of the various I/O ports on the rear of the motherboard.

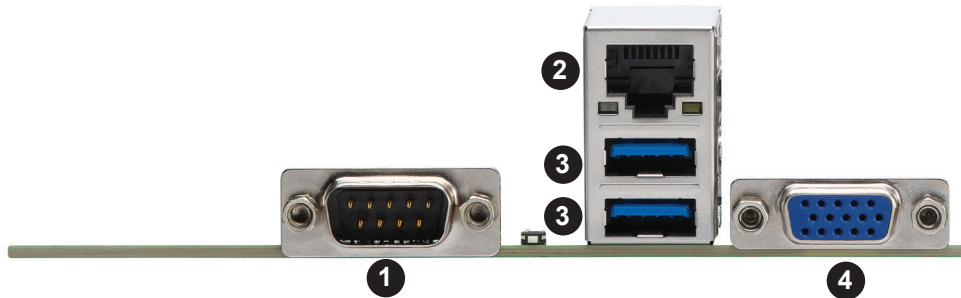

Figure 2-2. I/O Port Locations and Definitions

Rear I/O Ports			
#	Description	#	Description
1	COM Port	3	USB Ports (USB3.1)
2	IPMI LAN Port	4	VGA Port

COM Port

One serial communications (COM) port is included on the rear I/O panel.

IPMI LAN Port

One dedicated IPMI LAN port is located on the rear I/O panel. This port accepts an RJ45 type cable.

Universal Serial Bus (USB) Ports

There are two USB 3.1 ports (USB0/1) on the rear I/O panel. These support the type A connector.

VGA Port

There is one VGA port to the right of the USB ports on the rear I/O panel.

UID Switch and UID LED Indicator

A Unit Identifier (UID SW) switch and UID LED (LED1) are located on the rear I/O panel. The rear UID LED (LED1) is located next to the UID switch. When you press the UID switch, both rear and front UID LED indicators will turn on. Press the UID switch again to turn off the LED indicators. The UID Indicator provides easy identification of a system that may be in need of service. See 2.6 for the front panel UID LED header location on JF1.

Note: UID can also be triggered via IPMI on the serverboard. For more information on IPMI, please refer to the IPMI User's Guide posted on our website at <http://www.supermicro.com>

2.6 Connectors

M.2 Slots (JM2_A1, JM2_B1)

The M.2 slots are for Solid State Devices (SSDs) that conform to the PCIe M.2 specifications (formerly known as NGFF). These M.2 slots supports M-Key PCIe 4.0 storage cards with form factors of 2242, 2260, 2280, and 22110.

TPM Header/Port 80 Connector (TPM Port)

The JTPM2 header is used to connect a Trusted Platform Module (TPM), which is available from a third-party vendor. A TPM is a security device that supports encryption and authentication in hard drives. It enables the motherboard to deny access if the TPM associated with the hard drive is not installed in the system.

Please go to the following link for more information on TPM: <http://www.supermicro.com/manuals/other/TPM.pdf>.

Trusted Platform Module Header Pin Definitions			
Pin#	Definition	Pin#	Definition
1	LCLK	2	GND
3	LFRAME#	4	Key
5	LRESET#	6	N/C
7	LAD3	8	LAD2
9	3.3V	10	LAD1
11	LAD0	12	GND
13	SMB_CLK (optional)	14	SMB_DAT (optional)
15	P3V3_STBY	16	SERIRQ
17	GND	18	LP_CLKRUN (optional)
19	LPC_PD (optional)	20	LPC_DRQ (optional)

Onboard Battery (BT1)

The onboard back up battery is located at BT1. The onboard battery provides backup power to the on chip CMOS, which stores the BIOS' setup information. It also provides power to the Real Time Clock (RTC) to keep it running.

USB Ports (USB0/1, USB13)

There are a total of three USB ports supported on the motherboard, two are located on the rear I/O panel and one is provided as an onboard header for front system access.

Onboard USB 13 (2.0) Pin Definitions			
Pin#	Definition	Pin#	Definition
1	+5V	6	USB_P
2	+5V	7	Ground
3	USB_N	8	Ground
4	USB_N	9	Key
5	USB_P	10	NC

Rear I/O Panel USB 0/1 (USB3.1) Pin Definitions			
Pin#	Definition	Pin#	Definition
A1	VBUS	B1	Power
A2	D-	B2	USB_N
A3	D+	B3	USB_P
A4	GND	B4	GND
A5	Stda_SSTX-	B5	USB_3RN
A6	Stda_SSTX+	B6	USB3_RP
A7	GND	B7	GND
A8	Stda_SSTX-	B8	USB3_TN
A9	Stda_SSTX+	B9	USB3_TP

AIOM Slot

The Supermicro Advanced I/O Module (AIOM) PCIe 4.0 x16 slot (AIOM1) can be utilized to offer additional LAN ports, VPU, storage devices, etc. on the motherboard. Please visit the Supermicro website for all available module options. Also, please note that it is mandatory to unplug power cords prior to removing or installing an AIOM module card.

SlimSAS Ports

The H12SSG-ANP6 has 11 PCIe 4.0 SlimSAS ports designated JPCE1 through JPCE11. These SAS ports are supported by the chipset

IPMB (I²C) Header

A Management Bus header is located at JIPMB1. Connect the appropriate cable here to use the IPMB I²C connection on your system. Refer to the table below for pin definitions.

IPMB Header Pin Definitions	
Pin#	Definition
1	Data
2	Ground
3	Clock
4	No connection

GPU 12V 8-pin Power Connectors (JPWR1 - JPWR4)

JPWR1, JPWR2, JPWR3, and JPWR4 are all 8-pin 12V DC power inputs for GPUs that have been installed in the system's PCIe slots. Refer to the table below for pin definitions.

GPU 12V 8-pin Power Pin Definitions			
Pin#	Definition	Pin#	Definition
1	Ground	5	+12V
2	Ground	6	+12V
3	Ground	7	+12V
4	Ground	8	+12V

2.7 Jumper Settings

How Jumpers Work

To modify the operation of the motherboard, jumpers can be used to choose between optional settings. Jumpers create shorts between two pins to change the function of the connector. Pin #1 is identified with a thicker border line on the printed circuit board. See the diagram below for an example of jumping pins 1 and 2. Refer to the motherboard layout page for jumper locations.

Note: On two-pin jumpers, "Closed" means the jumper is on and "Open" means the jumper is off the pins.

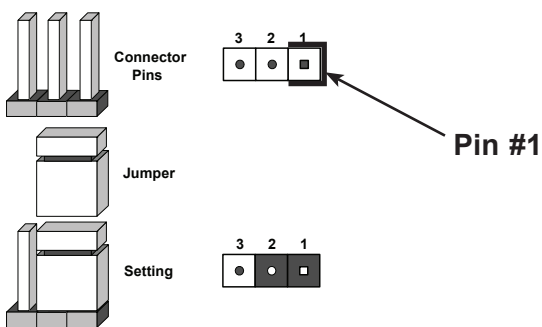

Clear CMOS (JBT1)

JBT1 is used to clear CMOS, which will also clear any passwords. Instead of pins, this jumper consists of contact pads to prevent accidentally clearing the contents of CMOS.

To Clear CMOS

1. First power down the system and unplug the power cord(s).
2. Remove the cover of the chassis to access the motherboard.
3. Remove the onboard battery from the motherboard.
4. Short the CMOS pads with a metal object such as a small screwdriver for at least four seconds.
5. Remove the screwdriver (or shorting device).
6. Replace the cover, reconnect the power cord(s), and power on the system.

Note: Clearing CMOS will also clear all passwords.

Do not use the PW_ON connector to clear CMOS.



Watch Dog (JWD1)

JWD1 controls the Watch Dog function. Watch Dog is a monitor that can reboot the system when a software application hangs. Jumping pins 1-2 will cause Watch Dog to reset the system if an application hangs. Jumping pins 2-3 will generate a non-maskable interrupt signal for the application that hangs. Watch Dog must also be enabled in BIOS. The default setting is Reset.

Note: When Watch Dog is enabled, the user needs to write their own application software to disable it.

Watch Dog Jumper Settings	
Jumper Setting	Definition
Pins 1-2	Reset (Default)
Pins 2-3	NMI
Open	Disabled

2.8 LED Indicators

IPMI LAN Port LEDs

The IPMI LAN port has two LED indicators. The Activity LED is green and indicates connection and activity. The Link LED may be green, orange/amber, or off to indicate the speed of the connection. Refer to the tables below for more information.

Link LED, Connection Link, Speed Indicator	
LED Color	Definition
Orange	1 Gb/s
Green	100 Mb/s

Activity LED		
Color	State	Definition
None	No Connection	
None	Off	Link
Yellow	Flashing	Active

Activity LED

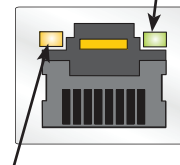

Link LED

UID LED Indicator (LED1)

The rear LED1 is located next to the UID switch. The front UID LED is located on the front panel. When you press the UID switch, both rear LED1 and front UID LED indicators will turn on. Press the UID switch again to turn off the LED indicators. Use this UID Indicator to 'mark' the system, so the system can be easily identified whether on the front or back (e.g., a system rack with multiple units installed).

UID LED LED Indicator		
Color	State	Definition
Blue	Solid On	Unit Identified
None	Off	UID Off

BMC Heartbeat LED (LEDM1)

A BMC Heartbeat LED is located at LEDM1 on the motherboard. When this LED is blinking, the BMC is functioning normally. See the table below for more information.

BMC Heartbeat LED State		
Color	State	Definition
Green	Solid On	BMC is not ready
Green	Blinking	BMC Normal
Green	Fast Blinking	BMC: Initializing

Power LED

The Power LED is designated as LED2 on the motherboard. When this LED is lit, it means that power is present on the motherboard. In suspend mode, this LED will blink on and off. Be sure to turn off the system and unplug the power cord(s) before removing or installing components.

Onboard Power LED Indicator	
LED Color	Definition
Off	System Off (power cable not connected)
Green	System On

M.2 Active LEDs (LED4 and LED5)

The M.2 Interface Detection LEDs indicate that an M.2 interface is detected, active and working correctly on either M.2-B1 (LE1) or M.2-A1 (LE2).

Note: M.2 SATA devices are not supported, but these LEDs turns on (green light) when they are installed.

M.2 Active LED Indicator	
LED Color	Definition
Off	Off (Normal)
Green	On (Device active or a M.2 SATA device detected)

Chapter 3

Troubleshooting

3.1 Troubleshooting Procedures

Use the following procedures to troubleshoot your system. If you have followed all of the procedures below and still need assistance, refer to the 'Technical Support Procedures' and/or 'Returning Merchandise for Service' section(s) in this chapter. Always disconnect the AC power cord before adding, changing or installing any non hot-swap hardware components.

Before Power On

1. Check that the power LED on the motherboard is on.
2. Make sure that the power connector is connected to your power supply.
3. Make sure that no short circuits exist between the motherboard and chassis.
4. Disconnect all cables from the motherboard, including those for the keyboard and mouse.
5. Remove all add-on cards.
6. Install a CPU, a heatsink*, and connect the power LED to the motherboard. Check all jumper settings as well. (Make sure that the heatsink is fully seated.)
7. Use the correct type of onboard CMOS battery (CR2032) as recommended by the manufacturer. To avoid possible explosion, do not install the CMOS battery upside down.

No Power

1. Make sure that no short circuits exist between the motherboard and the chassis.
2. Verify that all jumpers are set to their default positions.
3. Check that the 115V/230V switch on the power supply is properly set.
4. Turn the power switch on and off to test the system.
5. The battery on your motherboard may be old. Check to verify that it still supplies approximately 3VDC. If it does not, replace it with a new one.

No Video

1. If the power is on but you have no video, remove all the add-on cards and cables.
2. Set JPG1 to [1-2] and check if you follow the guidelines to install the memory module. See *DIMM Module Population* in chapter 2.
3. Reseat the memory DIMM modules.

Note: If you are a system integrator, VAR or OEM, a POST diagnostics card is recommended.

System Boot Failure

If the system does not display POST (Power-On-Self-Test) or does not respond after the power is turned on, check the following:

1. Clear the CMOS settings by unplugging the power cord and contacting both pads on the CMOS Clear Jumper (JBT1). See Section 2.8 for details.
2. Remove all components from the motherboard, especially the DIMM modules. Make sure that system power is on.
3. Turn on the system with only one DIMM module installed. If the system boots, check for bad DIMM modules or slots by following the Memory Errors Troubleshooting procedure in this Chapter.

Memory Errors

1. Make sure that the DIMM modules are properly and fully installed.
2. Confirm that you are using the correct memory. Also, it is recommended that you use the same memory type and speed for all DIMMs in the system. See Section 2.4 for memory details.
3. Check for bad DIMM modules or slots by swapping modules between slots and noting the results.
4. Check the power supply voltage 115V/230V switch.

The System Can't Retain the Setup Configuration

1. Make sure that you are using a high quality power supply. A poor quality power supply may cause the system to lose the CMOS setup information. Refer to Section 1 for details on power supplies.

2. The battery on your motherboard may be old. Check to verify that it still supplies approximately 3VDC. If it does not, replace it with a new one.
3. If the above steps do not fix the setup configuration problem, contact your vendor for repairs.

When the System Becomes Unstable

A. If the system becomes unstable during or after OS installation, check the following:

1. CPU/BIOS support: Make sure that your CPU is supported and that you have the latest BIOS installed in your system.
2. Memory support: Make sure that the memory modules are supported by testing the modules using memtest86 or a similar utility.

Note: Refer to the product page on our website at <http://www.supermicro.com> for memory and CPU support and updates.

3. HDD support: Make sure that all hard disk drives (HDDs) work properly. Replace the bad HDDs with good ones.
4. System cooling: Check the system cooling to make sure that all heatsink fans and CPU/system fans, etc., work properly. Check the hardware monitoring settings in the IPMI to make sure that the CPU and system temperatures are within the normal range. Also check the front panel Overheat LED and make sure that it is not on.
5. Adequate power supply: Make sure that the power supply provides adequate power to the system. Make sure that all power connectors are connected. Please refer to our website for more information on the minimum power requirements.
6. Proper software support: Make sure that the correct drivers are used.

B. If the system becomes unstable before or during OS installation, check the following:

1. Source of installation: Make sure that the devices used for installation are working properly, including boot devices such as USB flash or media drives.
2. Cable connection: Check to make sure that all cables are connected and working properly.
3. Using the minimum configuration for troubleshooting: Remove all unnecessary components (starting with add-on cards first), and use the minimum configuration (but with a CPU and a memory module installed) to identify the trouble areas. Refer to the steps listed in Section A above for proper troubleshooting procedures.

4. Identifying bad components by isolating them: If necessary, remove a component in question from the chassis, and test it in isolation to make sure that it works properly. Replace a bad component with a good one.
5. Check and change one component at a time instead of changing several items at the same time. This will help isolate and identify the problem.
6. To find out if a component is good, swap this component with a new one to see if the system will work properly. If so, then the old component is bad. You can also install the component in question in another system. If the new system works, the component is good and the old system has problems.

3.2 Technical Support Procedures

Before contacting Technical Support, please take the following steps. Also, note that as a motherboard manufacturer, we do not sell directly to end-users, so it is best to first check with your distributor or reseller for troubleshooting services. They should know of any possible problem(s) with the specific system configuration that was sold to you.

1. Please review the 'Troubleshooting Procedures' and 'Frequently Asked Questions' (FAQs) sections in this chapter or see the FAQs on our website before contacting Technical Support.
2. BIOS upgrades can be downloaded from our website. **Note:** Not all BIOS can be flashed depending on the modifications to the boot block code.
3. If you still cannot resolve the problem, include the following information when contacting us for technical support:
 - Motherboard model and PCB revision number
 - BIOS release date/version (this can be seen on the initial display when your system first boots up)
 - System configuration

An example of a Technical Support form is posted on our website.

Distributors: For immediate assistance, please have your account number ready when contacting our technical support department by e-mail.

3.3 Frequently Asked Questions

Question: What type of memory does my motherboard support?

Answer: The H12SSG-ANP6 motherboard supports up to 2TB registered ECC DDR4 up to 3200MHz memory in eight slots. See Section 2.4 for details on installing memory.

Question: How do I update my BIOS?

Answer: It is recommended that you **do not** upgrade your BIOS if you are not experiencing any problems with your system. Updated BIOS files are located on our website at <http://www.supermicro.com>.

To update your BIOS:

1. Check the BIOS warning message and the information on how to update your BIOS from our website.
2. Select your motherboard model and check the current BIOS revision to make sure it is newer than your motherboard's installed BIOS before downloading.
3. Download the zip file and save the BIOS package to your computer.
4. Unzip the BIOS files onto a USB stick with a FAT/FAT32 file system.
5. Boot to the motherboard's built-in UEFI Shell and type the following to start the BIOS update process:

FLASH.nsh BIOSname#.### <ENTER>

Note: Supermicro no longer supports the BIOS update method in DOS.

6. Perform an A/C power cycle after the message indicating the BIOS update has completed. You may refer to the "Readme" file in BIOS package for more details.

Question: Why can't I turn off the power using the momentary power on/off switch?

Answer: The instant power off function is controlled in BIOS by the Power Button Mode setting. When the On/Off feature is enabled, the motherboard will have instant off capabilities as long as the BIOS has control of the system. When the Standby or Suspend feature is enabled or when the BIOS is not in control such as during memory count (the first screen that appears when the system is turned on), the momentary on/off switch must be held for more than four seconds to shut down the system. This feature is required to implement the ACPI features on the motherboard.

3.4 Returning Merchandise for Service

A receipt or copy of your invoice marked with the date of purchase is required before any warranty service will be rendered. You can obtain service by calling your vendor for a Returned Merchandise Authorization (RMA) number. When returning to the manufacturer, the RMA number should be prominently displayed on the outside of the shipping carton and mailed prepaid or hand-carried. Shipping and handling charges will be applied for all orders that must be mailed when service is complete.

For faster service, RMA authorizations may be requested online (<http://www.supermicro.com/support/rma/>).

This warranty only covers normal consumer use and does not cover damages incurred in shipping or from failure due to the alteration, misuse, abuse or improper maintenance of products.

During the warranty period, contact your distributor first for any product problems.

3.5 Battery Removal and Installation

Battery Removal

To remove the onboard battery, follow the steps below:

1. Power off your system and unplug your power cable.
2. Locate the onboard battery as shown below.
3. Using a tool such as a pen or a small screwdriver, push the battery lock outwards to unlock it. Once unlocked, the battery will pop out from the holder.
4. Remove the battery.

Proper Battery Disposal

Please handle used batteries carefully. Do not damage the battery in any way; a damaged battery may release hazardous materials into the environment. Do not discard a used battery in the garbage or a public landfill. Please comply with the regulations set up by your local hazardous waste management agency to dispose of your used battery properly.

Battery Installation

1. To install an onboard battery, follow the steps 1 & 2 above and continue below:
2. Identify the battery's polarity. The positive (+) side should be facing up.
3. Insert the battery into the battery holder and push it down until you hear a click to ensure that the battery is securely locked.

Important: When replacing a battery, be sure to only replace it with the same type.

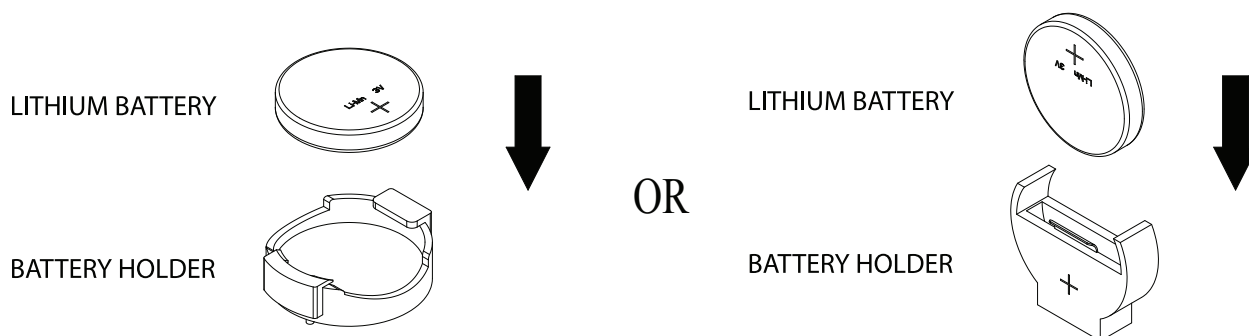

Figure 3-1. Battery Installation

Chapter 4

BIOS (Threadripper PRO 3000)

4.1 Introduction

This chapter describes the AMIBIOS™ Setup utility for the H12SSG-ANP6 motherboard. The BIOS is stored on a chip and can be easily upgraded using a flash program.

Note: Due to periodic changes to the BIOS, some settings may have been added or deleted and might not yet be recorded in this manual. Please refer to the Manual Download area of our website for any changes to BIOS that may not be reflected in this manual.

Starting the Setup Utility

To enter the BIOS Setup Utility, hit the <Delete> key while the system is booting-up. (In most cases, the <Delete> key is used to invoke the BIOS setup screen. There are a few cases when other keys are used, such as <F1>, <F2>, etc.) Each main BIOS menu option is described in this manual.

The Main BIOS screen has two main frames. The left frame displays all the options that can be configured. "Grayed-out" options cannot be configured. The right frame displays the key legend. Above the key legend is an area reserved for a text message. When an option is selected in the left frame, it is highlighted in white. Often a text message will accompany it. (Note that BIOS has default text messages built in. We retain the option to include, omit, or change any of these text messages.) Settings printed in **Bold** are the default values.

A "▶" indicates a submenu. Highlighting such an item and pressing the <Enter> key will open the list of settings within that submenu.

The BIOS setup utility uses a key-based navigation system called hot keys. Most of these hot keys (<F1>, <F2>, <F3>, <Enter>, <ESC>, <Arrow> keys, etc.) can be used at any time during the setup navigation process.

4.2 Main Setup

When you first enter the AMI BIOS setup utility, you will enter the Main setup screen. You can always return to the Main setup screen by selecting the Main tab on the top of the screen. The Main BIOS setup screen is shown below. The following Main menu items will be displayed:

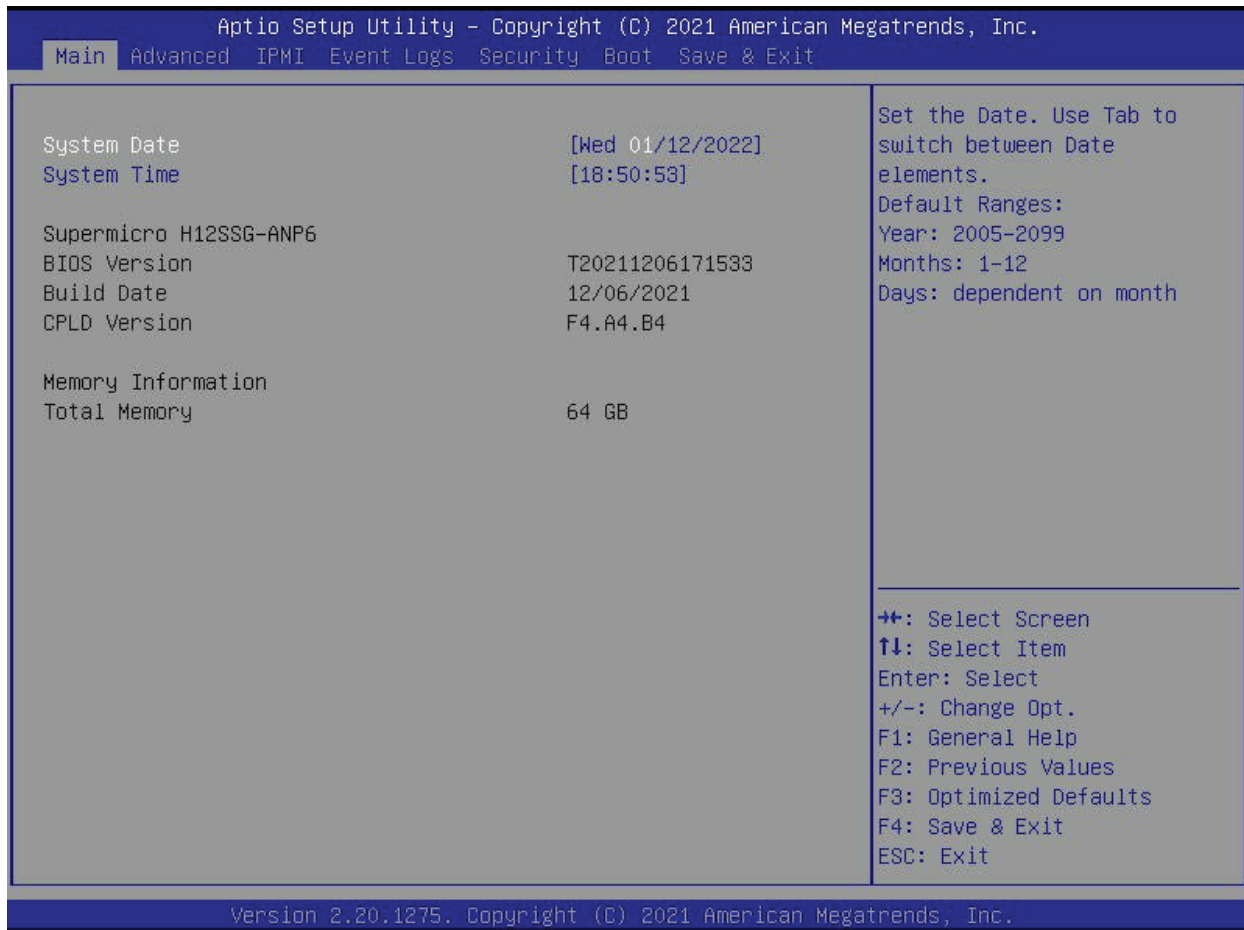

System Date/System Time

Use this option to change the system date and time. Highlight *System Date* or *System Time* using the arrow keys. Enter new values using the keyboard. Press the <Tab> key or the arrow keys to move between fields. The date must be entered in MM/DD/YYYY format. The time is entered in HH:MM:SS format.

Note: The time is in the 24-hour format. For example, 5:30 P.M. appears as 17:30:00. The date's default value is 01/01/2015 after RTC reset.

Supermicro H12SSG-ANP6

BIOS Version

This item displays the version of the BIOS ROM used in the system.

Build Date

This item displays the date when the version of the BIOS ROM used in the system was built.

CPLD Version

This item displays the CPLD version of the BIOS ROM used in the system.

Memory Information

Total Memory

This item displays the total size of memory available in the system.

4.3 Advanced

Use the arrow keys to select Boot Setup and press <Enter> to access the submenu items.

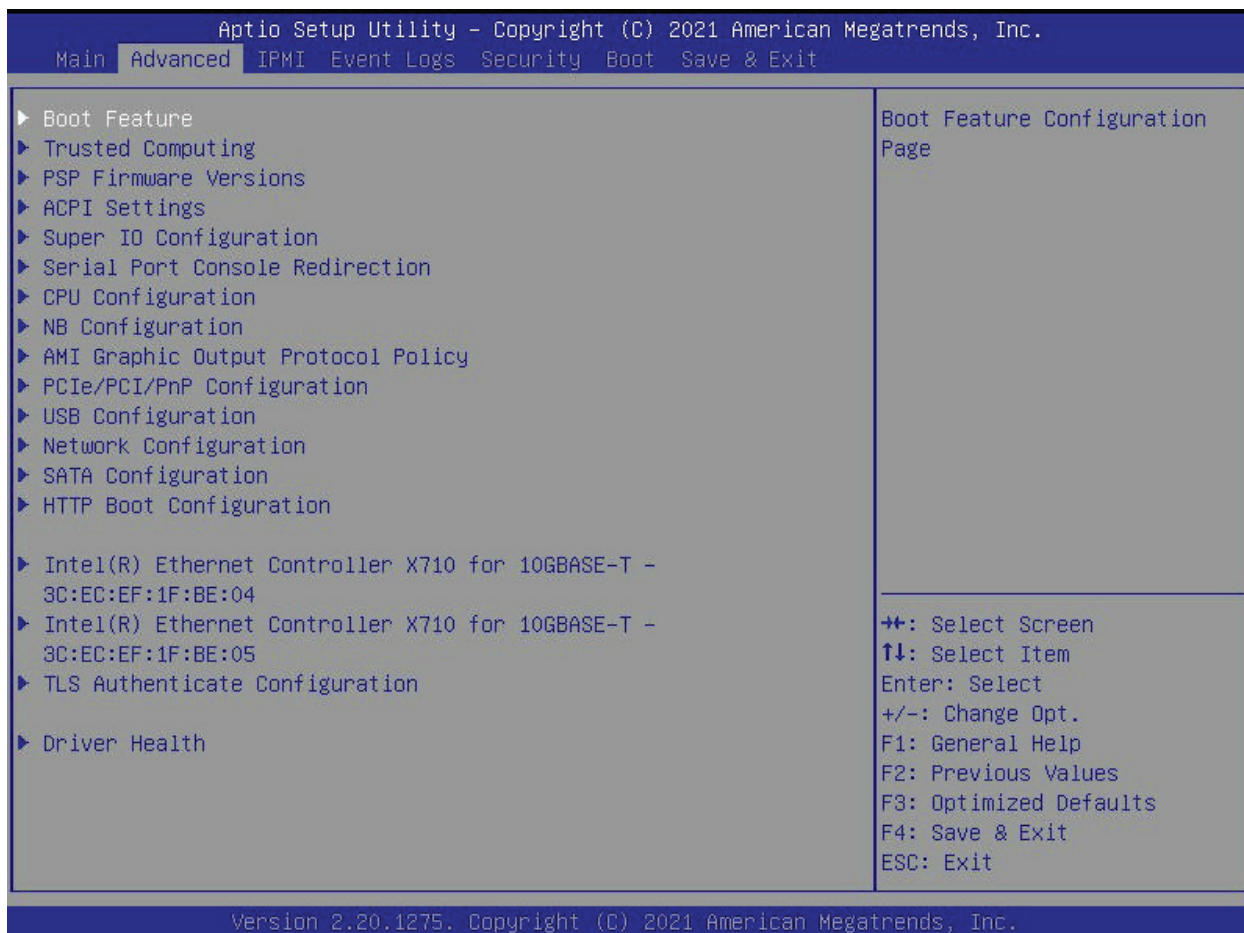

Warning: Take caution when changing the Advanced settings. An incorrect value, a very high DRAM frequency, or an incorrect DRAM timing setting may make the system unstable. When this occurs, revert to the manufacture default settings.

► Boot Feature

Quiet Boot

Use this feature to select the screen display between the POST messages and the OEM logo upon bootup. Select Disabled to display the POST messages. Select Enabled to display the OEM logo instead of the normal POST messages. The options are Disabled and **Enabled**.

Option ROM Messages

Use this feature to set the display mode for the Option ROM. Select Keep Current to display the current AddOn ROM setting. Select Force BIOS to use the Option ROM display set by the system BIOS. The options are **Force BIOS** and Keep Current.

Bootup NumLock State

Use this feature to set the Power on state for the <Numlock> key. The options are **On** and Off.

Wait For "F1" If Error

Use this feature to force the system to wait until the 'F1' key is pressed if an error occurs. The options are Disabled and **Enabled**.

INT19 (Interrupt 19) Trap Response

Interrupt 19 is the software interrupt that handles the boot disk function. When this item is set to Immediate, the ROM BIOS of the host adaptors will "capture" Interrupt 19 at bootup immediately and allow the drives that are attached to these host adaptors to function as bootable disks. If this item is set to Postponed, the ROM BIOS of the host adaptors will not capture Interrupt 19 immediately and allow the drives attached to these adaptors to function as bootable devices at bootup. The options are **Immediate** and Postponed.

Re-try Boot

If this item is enabled, the BIOS will automatically reboot the system from a specified boot device after its initial boot failure. The options are **Disabled**, Legacy Boot, and EFI Boot.

Power Configuration

Watch Dog Function

If enabled, the Watch Dog Timer will allow the system to reset or generate NMI based on jumper settings when it is expired for more than 5 minutes. The options are **Disabled** and Enabled.

Restore on AC Power Loss

Use this feature to set the power state after a power outage. Select Stay-Off for the system power to remain off after a power loss. Select Power-On for the system power to be turned on after a power loss. Select Last State to allow the system to resume its last power state before a power loss. The options are Stay Off, Power On, and **Last State**.

Power Button Function

This feature controls how the system shuts down when the power button is pressed. Select 4 Seconds Override for the user to power off the system after pressing and holding the power button for 4 seconds or longer. Select Instant Off to instantly power off the system as soon as the user presses the power button. The options are **Instant Off** and 4 Seconds Override.

► Trusted Computing

Configuration

Security Device Support

Enables or disables BIOS support for security device. OS will not show Security Device. TCG EFI protocol and INT1A interface will not be available. The options are **Disabled** and Enabled.

NO Security Device Found

►PSP Firmware Versions

This section displays the Platform Security Processor (PSP) firmware versions.

PSP Directory Level 1 (Fixed)

- PSP Recovery BL Ver
- SUM FW Version
- ABL Version

PSP Directory Level 2 (Updateable)

- PSP Bootloader Version
- SUM FW Version
- ABL Version

►ACPI Settings

PCI AER Support

The options are **Disabled** and Enabled.

High Precision Event Timer

The High Precision Event Timer (HPET) can produce periodic interrupts and is used to synchronize multimedia streams, providing smooth playback and reducing the need to use other timestamp calculations. The options are **Enabled** and Disabled.

NUMA Nodes Per Socket

The options are NPS0, NPS1, NPS2, NPS4 and **Auto**.

ACPI SRAT L3 Cache As NUMA Domain

The options are Disabled, Enabled and **Auto**.

►Super IO Configuration

The following Super IO information will display:

- Super IO Chip AST2600

► Serial Port 1 Configuration

Serial Port

Select Enabled to enable the selected onboard serial port. The options are Disabled and Enabled.

Device Settings

This item displays the status of a serial part specified by the user.

Change Settings

This feature specifies the base I/O port address and the Interrupt Request address of a serial port specified by the user. Select Auto to allow the BIOS to automatically assign the base I/O and IRQ address. The options are **Auto**, (IO=3F8h; IRQ=4;); (IO=3F8h; IRQ=3, 4, 5, 6, 7, 9, 10, 11, 12;); (IO=2F8h; IRQ=3, 4, 5, 6, 7, 9, 10, 11, 12;); (IO=3E8h; IRQ=3, 4, 5, 6, 7, 9, 10, 11, 12;); and (IO=2E8h; IRQ=3, 4, 5, 6, 7, 9, 10, 11, 12;).

► SOL Configuration

Serial Port

Select Enabled to enable the selected onboard serial port. The options are Disabled and Enabled.

Device Settings

This item displays the status of a serial part specified by the user.

Change SOL Settings

This feature specifies the base I/O port address and the Interrupt Request address of a serial port specified by the user. Select Auto to allow the BIOS to automatically assign the base I/O and IRQ address. The options are **Auto**, (IO=2F8h; IRQ=3;); (IO=3F8h; IRQ=3, 4, 5, 6, 7, 9, 10, 11, 12;); (IO=2F8h; IRQ=3, 4, 5, 6, 7, 9, 10, 11, 12;); (IO=3E8h; IRQ=3, 4, 5, 6, 7, 9, 10, 11, 12;); and (IO=2E8h; IRQ=3, 4, 5, 6, 7, 9, 10, 11, 12;)

► Serial Port Console Redirection

COM1

Console Redirection

Select Enabled to enable console redirection support for a serial port specified by the user. The options are Enabled and **Disabled**.

****If the item above set to Enabled, the following items will become available for user's configuration:***

► Console Redirection Settings

SOL

Console Redirection

Select Enabled to enable SOL console redirection support for a serial port specified by the user. The options are **Enabled** and Disabled.

**If the item above set to Enabled, the following items will become available for user's configuration:*

► Console Redirection Settings

Terminal Type

This feature allows the user to select the target terminal emulation type for Console Redirection. Select VT100 to use the ASCII Character set. Select VT100+ to add color and function key support. Select ANSI to use the Extended ASCII Character Set. Select VT-UTF8 to use UTF8 encoding to map Unicode characters into one or more bytes. The options are VT100, **VT100+**, VT-UTF8, and ANSI.

Bits per second

Use this feature to set the transmission speed for a serial port used in Console Redirection. Make sure that the same speed is used in the host computer and the client computer. A lower transmission speed may be required for long and busy lines. The options are 9600, 19200, 38400, 57600 and **115200** (bits per second).

Data Bits

Use this feature to set the data transmission size for Console Redirection. The options are 7 and 8.

Parity

A parity bit can be sent along with regular data bits to detect data transmission errors. Select Even if the parity bit is set to 0, and the number of 1's in data bits is even. Select Odd if the parity bit is set to 0, and the number of 1's in data bits is odd. Select None if you do not want to send a parity bit with your data bits in transmission. Select Mark to add a mark as a parity bit to be sent along with the data bits. Select Space to add a Space as a parity bit to be sent with your data bits. The options are **None**, Even, Odd, Mark, and Space.

Stop Bits

A stop bit indicates the end of a serial data packet. Select 1 Stop Bit for standard serial data communication. Select 2 Stop Bits if slower devices are used. The options are 1 and 2.

Flow Control

Use this feature to set the flow control for Console Redirection to prevent data loss caused by buffer overflow. Send a "Stop" signal to stop sending data when the receiving buffer is full. Send a "Start" signal to start sending data when the receiving buffer is empty. The options are **None** and Hardware RTS/CTS.

VT-UTF8 Combo Key Support

Select Enabled to enable VT-UTF8 Combination Key support for ANSI/VT100 terminals. The options are Disabled and **Enabled**.

Recorder Mode

Select Enabled to capture the data displayed on a terminal and send it as text messages to a remote server. The options are **Disabled** and Enabled.

Legacy OS Redirection Resolution

Select the screen resolution when the legacy operating system is being redirected. The options are 80x24 and **80x25**.

Resolution 100x31

Select Enabled for extended-terminal resolution support. The options are Disabled and **Enabled**.

Putty KeyPad

This feature selects the settings for Function Keys and KeyPad used for Putty, which is a terminal emulator designed for the Windows OS. The options are **VT100**, LINUX, XTERMR6, SC0, ESCN, and VT400.

Redirection After BIOS POST

Select Always Enable to redirect the console before booting the legacy operating system. Select Bootloader to disable console redirection. The options are **Always Enable** and Bootloader.

Legacy Console Redirection

Legacy Serial Redirection Port

For this setting, select a COM port to display redirection of Legacy OS and Legacy OPROM messages. Options include **COM1** and SOL.

Serial Port for Out-of-Band Management / Windows Emergency Management Services (EMS)

Console Redirection

Select Enabled to enable EMS console redirection support for a serial port specified by the user. The options are Enabled and **Disabled**.

**If the item above set to Enabled, the following items will become available for user's configuration:*

► CPU Configuration

SMT Control

Use this setting to disable symmetric multithreading. Options include Disabled and **Auto**.

Core Performance Boost

This setting is used to configure for Core Performance Boost. Options include **Auto** and Disabled.

Global C-state Control

This setting is used to configure for Global C-state Control. Options include Disabled, Enabled, and **Auto**.

Local APIC Mode

Options include Compatibility, xAPIC, x2APIC, and **Auto**.

CCD Control

Sets the number of CCDs to be used. Once this option has been used to remove any CCDs, a POWER CYCLE is required in order for future selections to take effect. Options include **Auto**, 2 CCDs, 3 CCDs, 4 CCDs, and 6 CCDs.

Core Control

Sets the number of cores to be used. Once this option has been used to remove any CCDs, a POWER CYCLE is required in order for future selections to take effect. Options include **Auto**, ONE (1+0), TWO (2+0), THREE (3+0), FOUR (4+0), FIVE (5+0), SIX (6+0), and SEVEN (7+0).

L1 Stream HW Prefetcher / L2 Stream HW Prefetcher

This setting is used to enable or disable the L1/L2 Stream Hardware Prefetcher. The options are Disabled, Enabled, and **Auto**.

SEV ASID Count

This field specifies the maximum valid ASID, which affects the maximum system physical address space. The options are 253 ASIDs, 509 ASIDs, and **Auto**.

SEV-ES ASID Space Limit Control

Auto or Manual to control SEV-ES ASID Space Limit. The options are **Auto** and Manual.

SVM Mode

This setting **Enables** or Disables CPU Virtualization.

► CPU1 Information

These sections are for informational purposes. They will display some details about the detected CPUs on the motherboard, such as:

- CPU Version
- Number of Cores Running
- Processor Family
- Processor Model
- Microcode Patch Level
- L1 Instruction Cache (Size/Method)
- L1 Data Cache (Size/Method)
- L2 Data Cache (Size/Method)
- L3 Cache per Scket (Size/Method)

► NB Configuration

Determinism Control

Use this setting to configure the Determinism Slider. Options include Manual and **Auto**.

cTDP Control

Use this setting to configure the cTDP Control. Options include **Auto** and Manual.

IOMMU

Use this setting to enable or disable IOMMU. Options include Disabled, Enabled, and **Auto**.

Package Power Limit Control

Set to **Auto** to use the fused PPT or Manual to allow the user to set a customized PPT.

APBDIS

Use this setting to . Options include 0, 1, and **Auto**.

DF Cstates

Options include Disabled, Enabled, and **Auto**.

Preferred IO

Options include Manual and **Auto**.

► Memory Configuration

Memory Clock

This setting allows you to select different memory clock speed. Options include **Auto**, 2667 MHz, 2933 MHz, and 3200 MHz.

Memory interleaving

This setting controls fabric level memory interleaving. Note that the channel, die and socket have requirements on memory populations and it will be ignored if the memory doesn't support the selected option. Options include Disabled and **Auto**.

Memory interleaving size

This setting controls the memory interleaving size. This determines the starting address of the interleave (bit 8, 9, 10 or 11). Options include 256 Bytes, 512 Bytes, 1 KB, 2 KB, 4 KB, and **Auto**.

Chipset Interleaving

This setting controls interleave memory blocks across the DRAM chip for node 0. Options include Disabled and **Auto**.

BankGroupSwap

This setting controls the Bank Group Swap. Options include Enabled, Disabled and **Auto**

DRAM Scrub Time

This setting provides a value that is the number of hours to scrub memory. Options include Disabled, 1 hour, 4 hours, 8 hours, 16 hours, 24 hours, 48 hours, and **Auto**.

TSME

Use this setting to enable or disable TSME. Options include Disabled, Enabled, and **Auto**.

DDR Power Down Enable

Use this setting to control DDR Power Down Enable. Options include Disabled, Enabled, and **Auto**.

► CPU1 Memory Information

Provides information on CPU1 DIMMs.

► AMI Graphic Output Protocol Policy

► PCIe/PCI/PnP Configuration

This menu provides PCIe/PCI/PnP configuration settings and information.

PCI Bus Driver Version

PCI Devices Common Settings:

Above 4G Decoding

This setting **Enables** or Disables 64-bit capable devices ability to be decoded in above 4G address space (only if the system supports 64-bit PCI decoding).

SR-IOV Support

If the system has SR-IOV capable PCI-E devices, this setting will Enable or **Disable** the Single Root IO Virtualization Support for the system.

BME DMA Mitigation

Use this setting to re-enable the Bus Master Attribute that was disabled during PCI enumeration for PCI bridges after SMM is locked. The options are **Disabled** and Enabled.

PCIe ARI Support

Use this setting to enable or disable Alternative Routing-ID Interpretation. The options are Disabled, Enabled and **Auto**.

PCIe Ten Bit Tag Support

Use this setting to enable PCIe ten bit tags for supported devices. The options are Disabled, Enabled and **Auto**.

PCIe Spread Spectrum

Use this setting to Enable or **Disable** PCIe Spread Spectrum for your system.

Relaxed Ordering

Use this setting to Enable or **Disable** PCI Express Device Relaxed Ordering.

No Snoop

Use this setting to **Enable** or Disable PCI Express Device No Snoop option.

VGA Priority

Use this setting to select between onboard or offboard VGA support. The options are **Onboard** and Offboard.

NVMe Firmware Source

Use this setting to select between the AMI Native firmware support or the device vendor-defined firmware support. The options are AMI Native Support and **Vendor Defined Firmware**.

M.2 (AHCI) Firmware Source

Use this setting to select between the AMI Native firmware support or the device vendor-defined firmware support. The options are AMI Native Support and **Vendor Defined Firmware**.

JM2_A1 OPROM

Use this setting to enable or disable the JM2_A1 OPROM option. The options are Disabled and **EFI**.

AIOM OPROM

Use this setting to enable or disable the AIOM OPROM option. The options are Disabled and **EFI**.

JM2_B1 OPROM

Use this setting to enable or disable the JM2_B1 OPROM option. The options are Disabled and **EFI**.

RSC-WR-6 Slot1 PCI-E 4.0 x16 OPROM

Use this setting to enable or disable PCI/PCIX/PCIe slot 6. The options are Disabled and **EFI**.

RSC-GB-6 Slot1 PCI-E 4.0 x16 OPROM

Use this setting to enable or disable PCI/PCIX/PCIe slot 6. The options are Disabled and **EFI**.

AOC-UR-i2XT LAN1 OPROM

Use this setting to select which firmware is loaded for onboard LAN1. The options are Disabled and **EFI**.

Onboard NVMe1 Option ROM

Use this setting to select which firmware is loaded for onboard NVMe1. The options are Disabled and **EFI**.

Onboard NVMe2 Option ROM

Use this setting to select which firmware is loaded for onboard NVMe2. Options include Disabled and **EFI**.

►USB Configuration**Legacy USB Support**

Use this setting to enable USB legacy support. Auto disabled support if no USB devices are connected. Disable will keep USB devices available only for EFI applications Options are **Enabled**, Disabled, and Auto.

XHCI Hand-off

Workaround for OS's without XHCI support. The XHCI ownership change should be claimed by the XHCI driver. Options are **Enabled** and Disabled.

Port 60/64 Emulation

Enables I/O port 60h/64h emulation support. This should be enabled for complete USB keyboard legacy support for non-USB aware OS's. Options are **Enabled** and Disabled.

► Network Configuration

Network Stack

This setting allows you to **Enable** or Disable the UEFI Network Stack.

IPv4 PXE Support

This setting allows you to **Enable** or Disable IPv4 PXE boot support. If disabled, IPv4 PXE boot support will not be available.

IPv4 HTTP Support

This setting allows you to Enable or **Disable** IPv4 HTTP boot support. If disabled, IPv4 HTTP boot support will not be available.

IPv6 PXE Support

This setting allows you to **Enable** or Disable IPv6 PXE boot support. If disabled, IPv6 PXE boot support will not be available.

IPv6 HTTP Support

This setting allows you to Enable or **Disable** IPv6 HTTP boot support. If disabled, IPv6 HTTP boot support will not be available.

PXE Boot Wait Time

This setting allows you to set in a number field the wait time to press the ESC key to abort the PXE boot. Default is **0**.

Media Detect Count

This setting allows you set in a number field the number of times presence of media will be checked. Default is **1**.

► MAC:3CECEF4B0AEC - IPv4 Network Configuration

Use this setting to view IPv4 network configuration.

► MAC:3CECEF4B0AEC - IPv6 Network Configuration

Use this setting to view IPv6 network configuration.

► MAC:3CECEF4B0AED - IPv4 Network Configuration

Use this setting to view IPv4 network configuration.

▶MAC:3CECEF4B0AED - IPv6 Network Configuration

Use this setting to view IPv6 network configuration.

▶MAC:3CECEF4B0AEE - IPv4 Network Configuration

Use this setting to view IPv4 network configuration.

▶MAC:3CECEF4B0AEE - IPv6 Network Configuration

Use this setting to view IPv6 network configuration.

▶MAC:3CECEF4B0AEF - IPv4 Network Configuration

Use this setting to view IPv4 network configuration.

▶MAC:3CECEF4B0AEF - IPv6 Network Configuration

Use this setting to view IPv6 network configuration.

▶SATA Configuration**SATA Information****SATA Enable**

Use this setting to disable or enable OnChip SATA controller. Options are Disabled, Enabled, and **Auto**.

SATA Hotplug

Use this setting to disable or enable OnChip SATA Hotplug function. Options are Disabled and **Enabled**.

▶SATA Information

Use this setting to view SATA devices information.

▶HTTP Boot Configuration**HTTP Boot Configuration****HTTP Boot Policy**

Sets the HTTP boot policy to Apply to all LANs, **Apply to each LAN**, and Boot Priority #1 instantly.

HTTPS Boot Checks Hostname

This feature checks if the hostname of the TLS certificates matches the hostname provided by the remote server. The options are **Enabled** and Disabled (WARNING: Security Risk!!).

Priority of HTTP Boot

Instance of Priority 1

Default to 1.

Select IPv4 of IPv6

Choose to set the targeted LAN port to boot from **IPv4** or IPv6.

Boot Description

Must be filled out, otherwise boot option for the URI will not be created. Length of description cannot exceed 75 characters.

Boot URI

This option is an input field used to enter a web or network address to point to the HTTP boot files. This supports the HTTP or HTTPS protocols only.

Instance of Priority 2

Rank targeted port.

► Intel(R) I350 Gigabit Network Connection - 3C:EC:EF:B4:0A:EC

Port Configuration Menu

► NIC Configuration

Link Speed

Select the link speed and duplex for current port. The options are **AutoNeg**, 10 Mbps Half, 10 Mbps Full, 100 Mbps Half, and 100 Mbps Full.

Wake on LAN

This feature wakes up the system with a magic packet. The options are Disabled and Enabled.

Blink LEDs (range 0-15 seconds)

Set to blink LEDs for the specifies duration (uo to 15 seconds).

Port Configuration Information

UEFI Driver

Adapter PBA

Chip Type

PCI Device ID

PCI Bus:Device:Function:

Link Status

Factory MAC Address

Alternate MAC Address

▶ Intel(R) I350 Gigabit Network Connection - 3C:EC:EF:B4:0A:ED

Port Configuration Menu

▶ NIC Configuration

Link Speed

Select the link speed and duplex for current port. The options are **AutoNeg**, 10 Mbps Half, 10 Mbps Full, 100 Mbps Half, and 100 Mbps Full.

Wake on LAN

This feature wakes up the system with a magic packet. The options are Disabled and Enabled.

Blink LEDs (range 0-15 seconds)

Set to blink LEDs for the specifies duration (up to 15 seconds).

Port Configuration Information

UEFI Driver

Adapter PBA

Chip Type

PCI Device ID

PCI Bus:Device:Function:

Link Status

Factory MAC Address

Alternate MAC Address

▶ Intel(R) I350 Gigabit Network Connection - 3C:EC:EF:B4:0A:EE

Port Configuration Menu

▶ NIC Configuration

Link Speed

Select the link speed and duplex for current port. The options are **AutoNeg**, 10 Mbps Half, 10 Mbps Full, 100 Mbps Half, and 100 Mbps Full.

Wake on LAN

This feature wakes up the system with a magic packet. The options are Disabled and Enabled.

Blink LEDs (range 0-15 seconds)

Set to blink LEDs for the specifies duration (up to 15 seconds).

Port Configuration Information

UEFI Driver

Adapter PBA

Chip Type

PCI Device ID

PCI Bus:Device:Function:

Link Status

Factory MAC Address

Alternate MAC Address

▶ Intel(R) I350 Gigabit Network Connection - 3C:EC:EF:B4:0A:EF

Port Configuration Menu

▶ NIC Configuration

Link Speed

Select the link speed and duplex for current port. The options are **AutoNeg**, 10 Mbps Half, 10 Mbps Full, 100 Mbps Half, and 100 Mbps Full.

Wake on LAN

This feature wakes up the system with a magic packet. The options are Disabled and Enabled.

Blink LEDs (range 0-15 seconds)

Set to blink LEDs for the specifies duration (up to 15 seconds).

Port Configuration Information

UEFI Driver

Adapter PBA

Chip Type

PCI Device ID

PCI Bus:Device:Function:

Link Status

Factory MAC Address

Alternate MAC Address

▶ TLS Authenticate Configuration

This submenu allows the user to configure Transport Layer Security (TLS) settings.

▶ Server CA Configuration

▶ Enroll Certification

▶ Enroll Certification Using File

Use this feature to enroll certification from a file.

Certification GUID

Use this feature to input the certification GUID.

▶ Commit Changes and Exit

Use this feature to save all changes and exit TLS settings.

▶ Discard Changes and Exit

Use this feature to discard all changes and exit TLS settings.

▶ Delete Certification

Use this feature to delete certification. The options include **Disabled** and **Enabled**.

▶ Driver Health

▶ **Intel 10GbE Driver 5.8.06 x64**

This provides the health status for the drivers and controllers.

4.4 IPMI

This tab allows you to configure the following IPMI settings for the system.

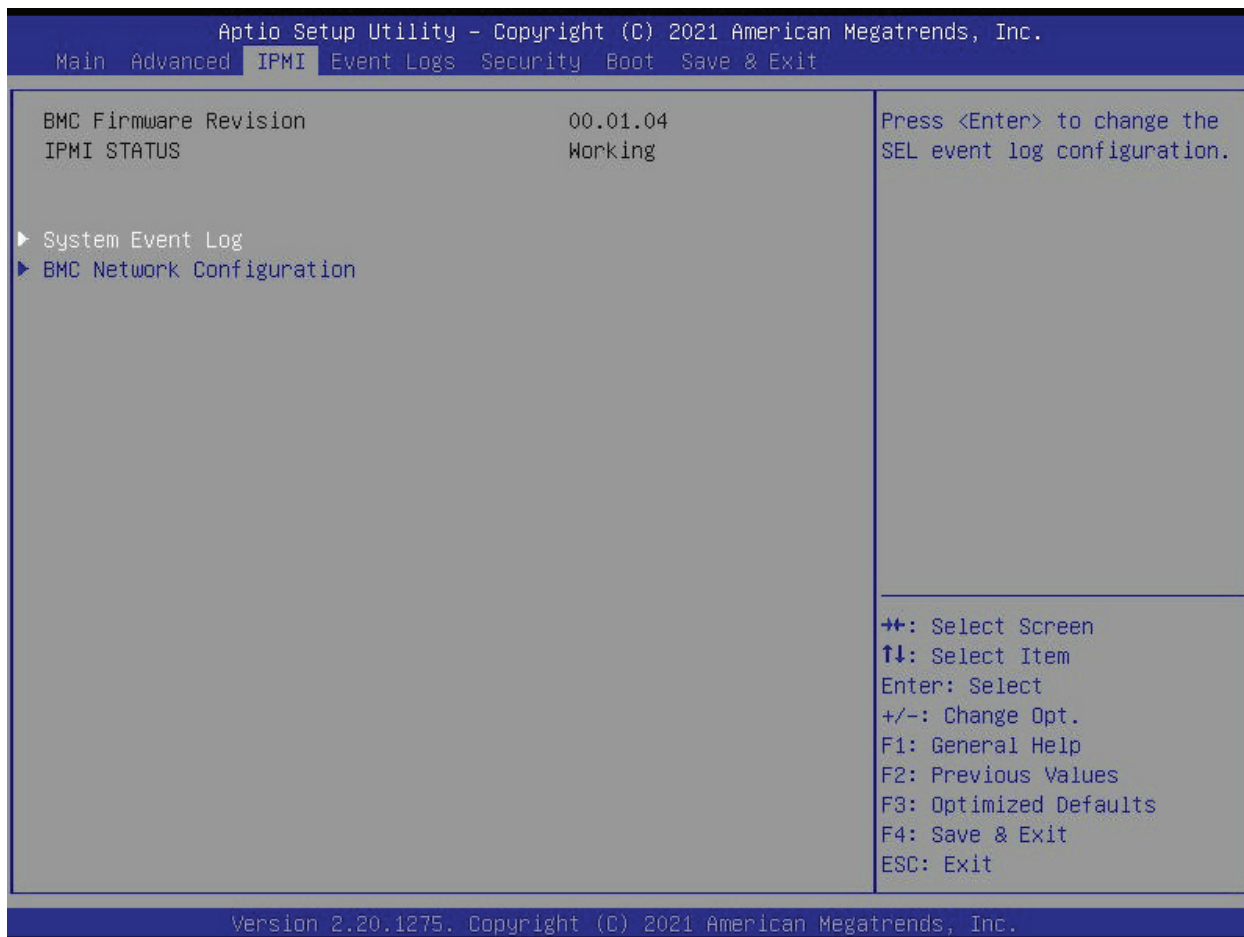

Use this feature to configure Intelligent Platform Management Interface (IPMI) settings.

BMC Firmware Revision

This item indicates the IPMI firmware revision used in your system.

IPMI Status

This item indicates the status of the IPMI firmware installed in your system.

▶ System Event Log

Enabling/Disabling Options

SEL Components

Select Enabled for all system event logging at bootup. The options are Disabled and Enabled.

Erasing Settings

Erase SEL

Select Yes, On next reset to erase all system event logs upon next system reboot. Select Yes, On every reset to erase all system event logs upon each system reboot. Select No to keep all system event logs after each system reboot. The options are **No**, Yes, On next reset, and Yes, On every reset.

When SEL is Full

This feature allows the user to decide what the BIOS should do when the system event log is full. Select Erase Immediately to erase all events in the log when the system event log is full. The options are **Do Nothing** and Erase Immediately.

Note: After making changes on a setting, be sure to reboot the system for the changes to take effect.

► BMC Network Configuration**BMC Network Configuration****Configure IPV4/IPV6 Support**

This section displays static configuration features for IPV4 support.

IPMI LAN Selection

This item displays the IPMI LAN setting. The default setting is **Failover**.

IPMI Network Link Status

This item displays the IPMI Network Link status. The default setting is **Shared LAN**.

Configuration Address Source

This feature allows the user to select the source of the IP address for this computer. If Static is selected, you will need to know the IP address of this computer and enter it to the system manually in the field. If DHCP is selected, the BIOS will search for a DHCP (Dynamic Host Configuration Protocol) server in the network that is attached to and request the next available IP address for this computer. The options are **DHCP** and Static.

****If the item above is set to Static, the following items will become available for configuration:***

Station IP Address

This item displays the Station IP address for this computer. This should be in decimal and in dotted quad form.

Subnet Mask

This item displays the Subnet Mask for this computer. This should be in decimal and in dotted quad form.

Station MAC Address

This item displays the Station MAC address for this computer. This should be in decimal and in dotted quad form.

Gateway IP Address

This item displays the Gateway IP address for this computer. This should be in decimal and in dotted quad form (i.e., 172.31.0.1).

VLAN

This item displays the virtual LAN settings. The options are **Disabled** and Enabled.

4.5 Event Logs

This tab allows the user to configure the following event logs settings for the system.

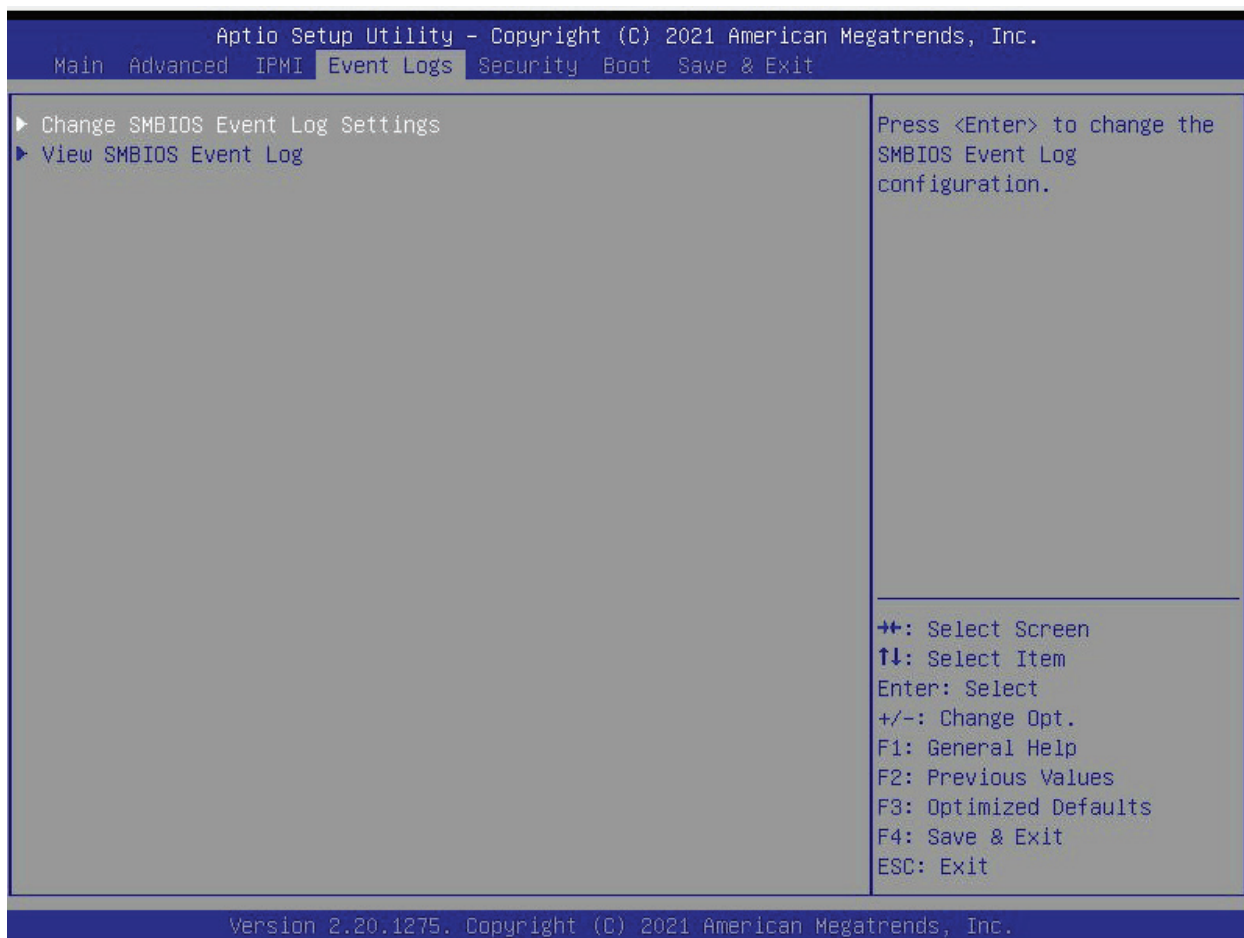

► Change SMBIOS Event Log Settings

This feature allows the user to configure SMBIOS Event settings.

Enabling/Disabling Options

SMBIOS Event Log

Select Enabled to enable SMBIOS (System Management BIOS) Event Logging during system boot. The options are Disabled and **Enabled**.

Erasing Settings

Erase Event Log

Select Yes to erase all error events in the SMBIOS (System Management BIOS) log before an event logging is initialized at bootup. The options are **No**, Yes, Next reset, and Yes, every reset.

When Log is Full

Select Erase Immediately to immediately erase all errors in the SMBIOS event log when the event log is full. Select Do Nothing for the system to do nothing when the SMBIOS event log is full. The options are **Do Nothing** and Erase Immediately.

SMBIOS Event Log Standard Settings**Log System Boot Event**

Select Enabled to log system boot events. The options are Enabled and **Disabled**.

MECI (Multiple Event Count Increment)

Enter the increment value for the multiple event counter. Enter a number between 1 to 255. The default setting is **1**.

METW (Multiple Event Count Time Window)

This item is used to determine how long (in minutes) the multiple event counter should wait before generating a new event log. Enter a number between 0 to 99. The default setting is **60**.

Note: Please reboot the system for these changes to take effect.

►View SMBIOS Event Log

When Event Logging is on, this item allows the user to view the entries in the SMBIOS event log. The following categories are displayed:

Date/Time/Error Code/Severity

4.6 Security

This tab allows you to configure the following security settings for the system.

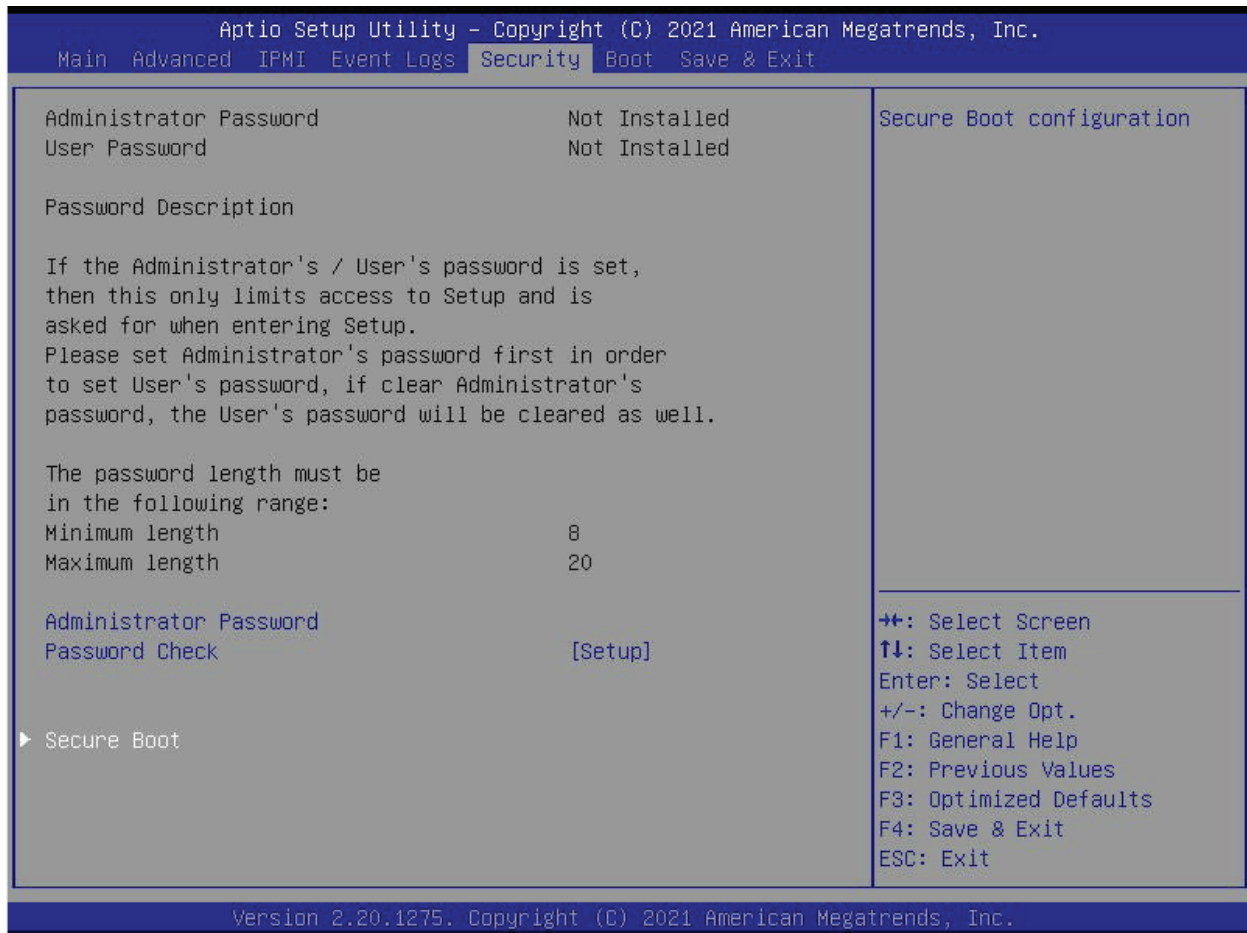

Administrator Password

Press Enter to create a new, or change an existing Administrator password. Note that if the Administrator Password is erased, the User Password will be cleared as well.

User Password

Press Enter to create a new, or change an existing User password.

Administrator Password

Press Enter to set the administrator password.

Password Check

Select Setup for the system to check for a password at Setup. Select Always for the system to check for a password at bootup or upon entering the BIOS Setup utility. The options are **Setup** and **Always**.

► Secure Boot

This section contains options and menus for securing your boot mode and for key management.

Secure Boot

This option allows you specify when the Platform Key (PK) is enrolled. When enabled, the System Mode is user deployed, and the CSM function is disabled. Options include Enabled and **Disabled**.

Secure Boot Mode

Use this item to select the secure boot mode. The options are Standard and **Custom**.

CSM Support

Select Enabled to support the EFI Compatibility Support Module (CSM), which provides compatibility support for traditional legacy BIOS for system boot. The options are Disabled and **Enabled**.

► Key Management

This submenu allows the user to configure the following Key Management settings.

Vendor Keys

Provision Factory Defaults

Select Enabled to install the default Secure-Boot keys set by the manufacturer. The options are Disabled and Enabled. The options include Disabled and **Enabled**.

► Restore Factory Keys

Select Yes to install all default secure keys set by the manufacturer. The options are **Yes** and No.

► Reset To Setup Mode

► Export Secure Boot variables

► Enroll EFI Image

This allows the image to run in Secure Boot Mode, and enroll SHA256 hash of the binary into an Authorized Signature Database (db).

Device Guard Ready

► Remoe 'UEFI CA' from DB

► Restore DB defaults

The options are **Yes** and No.

Secure Boot Variable

This feature allows you to decide if all secure boot variables should be saved.

►Platform Key (PK)

This feature allows you to configure the settings of the platform keys.

Set New Key

Select Yes to load the new platform keys (PK) from the manufacturer's defaults. Select No to load the platform keys from a file. The options are **Yes** and No.

Provision Factory Default Keys

Select Enabled to install the default Secure-Boot keys set by the manufacturer. The options are **Disabled** and Enabled.

►Key Exchange Keys

This feature allows you to configure the settings of the Key Exchange Keys. The options include **Update** and Append.

►Authorized Signatures

This feature allows you to configure the settings of the Authorized Signatures. The options include **Update** and Append.

►Forbidden Signatures

This feature allows you to configure the settings of the Forbidden Signatures. The options include **Update** and Append.

►Authorized TimeStamps

This feature allows you to configure the settings of the authorized TimeStamps. The options include **Update** and Append.

►OsRecovery Signature

This feature allows you to configure the settings of the authorized OsRecovery Signature. The options include **Update** and Append.

4.7 Boot

Use this tab to configure Boot Settings:

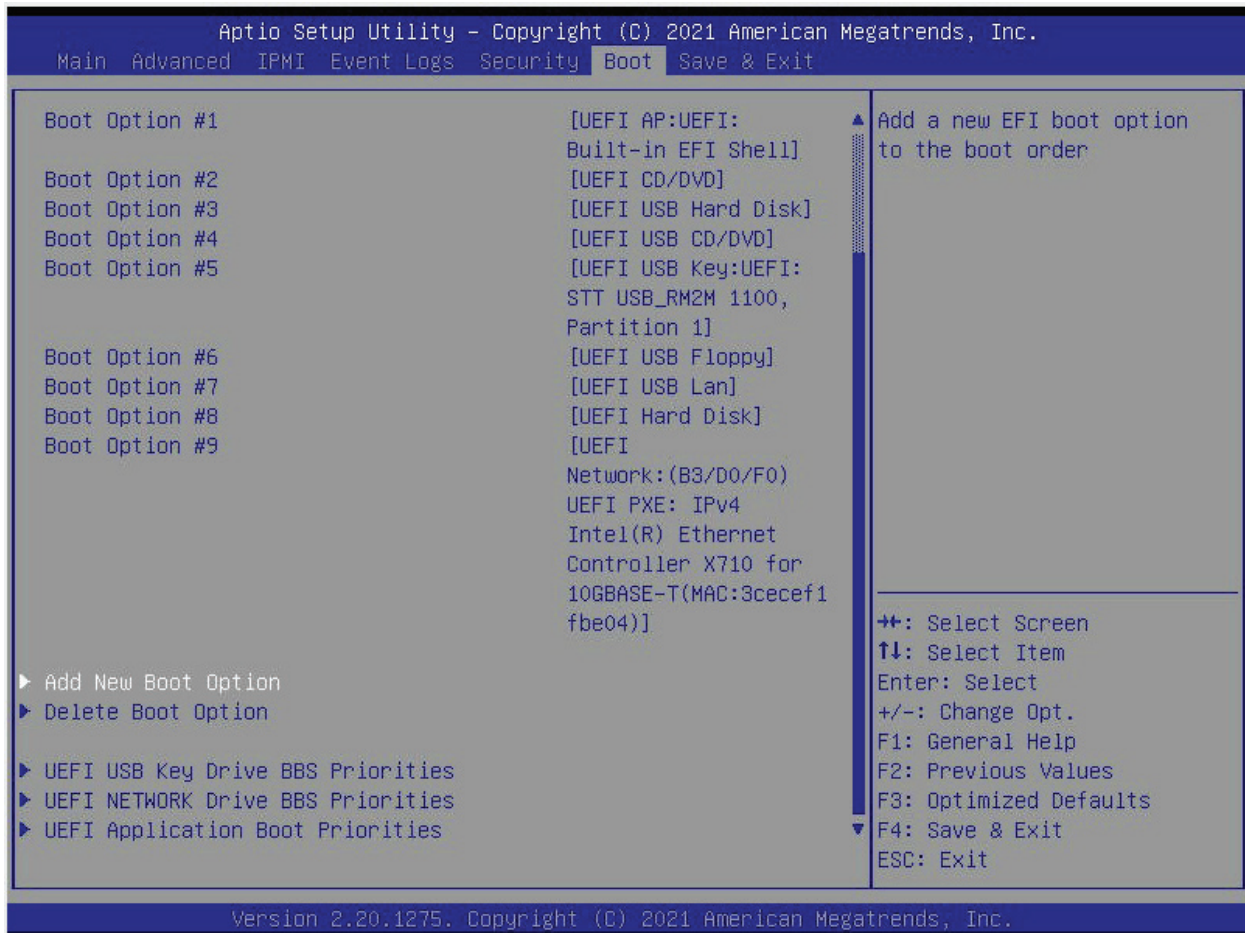

Boot Mode Select

Use this item to select the type of device that the system is going to boot from. The options are Legacy, **UEFI**, and Dual. The default setting is DUAL.

Legacy to EFI Support

This option Enables or **Disables** the system to boot to an EFI OS after the boot failed from the legacy boot order.

FIXED BOOT ORDER Priorities

This option prioritizes the order of bootable devices. Press <Enter> on each entry from top to bottom to select devices.

Boot Option #1

Use this feature to add a boot option to the boot order.

Boot Option #2

Use this feature to add a boot option to the boot order.

Boot Option #3

Use this feature to add a boot option to the boot order.

Boot Option #4

Use this feature to add a boot option to the boot order.

Boot Option #5

Use this feature to add a boot option to the boot order.

Boot Option #6

Use this feature to add a boot option to the boot order.

Boot Option #7

Use this feature to add a boot option to the boot order.

Boot Option #8

Use this feature to add a boot option to the boot order.

Boot Option #9

Use this feature to add a boot option to the boot order.

►Delete Boot Option

Use this feature to remove a pre-defined boot device from which the system will boot during startup. The settings are [any pre-defined boot device].

►UEFI Hard Disk Drive BBS Priorities

This feature allows the user to specify which UEFI devices are boot devices.

- Boot Option #1
- Boot Option #2
- Boot Option #3
- Boot Option #4
- Boot Option #5

►UEFI Network Drive BBS Priorities

This feature specifies the boot device priority sequence from the available UEFI network drives.

- Boot Option #1

► UEFI Application Boot Priorities

This feature allows the user to specify which UEFI devices are boot devices.

- Boot Option #1

4.8 Save & Exit

Select the Save & Exit tab to enter the Save & Exit BIOS Setup screen.

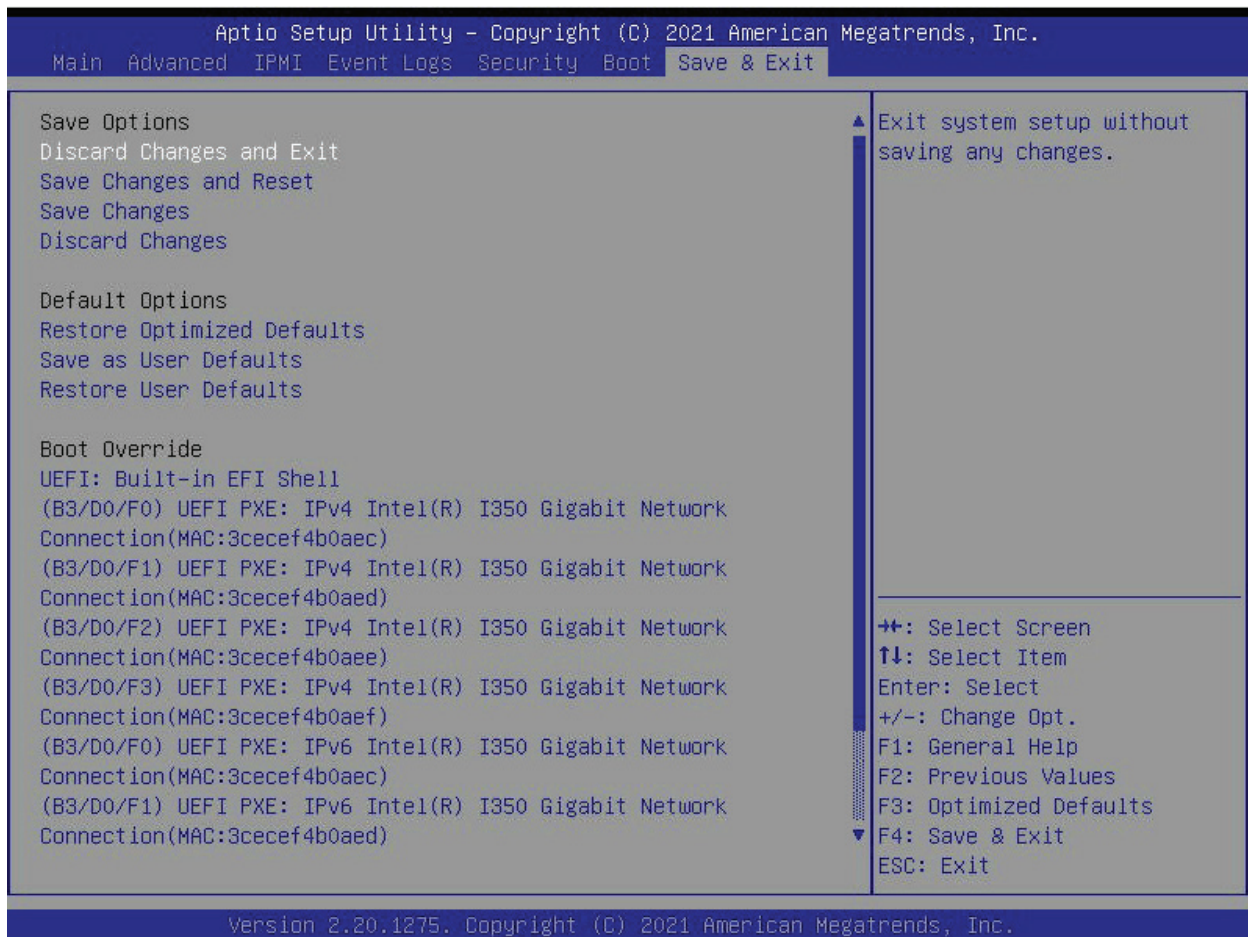

Discard Changes and Exit

Select this option to quit the BIOS Setup without making any permanent changes to the system configuration, and reboot the computer. Select Discard Changes and Exit from the Exit menu and press <Enter>.

Save Changes and Reset

Select this option to reset the system after saving the changes.

Save Changes

After completing the system configuration changes, select this option to save the changes you have made. This will not reset (reboot) the system.

Discard Changes

Select this option and press <Enter> to discard all the changes and return to the AMI BIOS utility Program.

Default Options

Restore Optimized Defaults

To set this feature, select Restore Defaults from the Save & Exit menu and press <Enter>. These are factory settings designed for maximum system stability, but not for maximum performance.

Save as User Defaults

To set this feature, select Save as User Defaults from the Exit menu and press <Enter>. This enables the user to save any changes to the BIOS setup for future use.

Restore User Defaults

To set this feature, select Restore User Defaults from the Exit menu and press <Enter>. Use this feature to retrieve user-defined settings that were saved previously.

Boot Override

Listed on this section are other boot options for the system (i.e., Built-in EFI shell). Select an option and press <Enter>. Your system will boot to the selected boot option.

Launch EFI Shell from filesystem device

Use this feature to launch an EFI Shell application (Shell.efi) from one of the available file system devices.

Chapter 5

BIOS (Threadripper PRO 5000)

5.1 Introduction

This chapter describes the AMIBIOS™ Setup utility for the H12SSG-ANP6 motherboard. The BIOS is stored on a chip and can be easily upgraded using a flash program.

Note: Due to periodic changes to the BIOS, some settings may have been added or deleted and might not yet be recorded in this manual. Please refer to the Manual Download area of our website for any changes to BIOS that may not be reflected in this manual.

Starting the Setup Utility

To enter the BIOS Setup Utility, hit the <Delete> key while the system is booting-up. (In most cases, the <Delete> key is used to invoke the BIOS setup screen. There are a few cases when other keys are used, such as <F1>, <F2>, etc.) Each main BIOS menu option is described in this manual.

The Main BIOS screen has two main frames. The left frame displays all the options that can be configured. "Grayed-out" options cannot be configured. The right frame displays the key legend. Above the key legend is an area reserved for a text message. When an option is selected in the left frame, it is highlighted in white. Often a text message will accompany it. (Note that BIOS has default text messages built in. We retain the option to include, omit, or change any of these text messages.) Settings printed in **Bold** are the default values.

A "▶" indicates a submenu. Highlighting such an item and pressing the <Enter> key will open the list of settings within that submenu.

The BIOS setup utility uses a key-based navigation system called hot keys. Most of these hot keys (<F1>, <F2>, <F3>, <Enter>, <ESC>, <Arrow> keys, etc.) can be used at any time during the setup navigation process.

5.2 Main Setup

When you first enter the AMI BIOS setup utility, you will enter the Main setup screen. You can always return to the Main setup screen by selecting the Main tab on the top of the screen. The Main BIOS setup screen is shown below. The following Main menu items will be displayed:

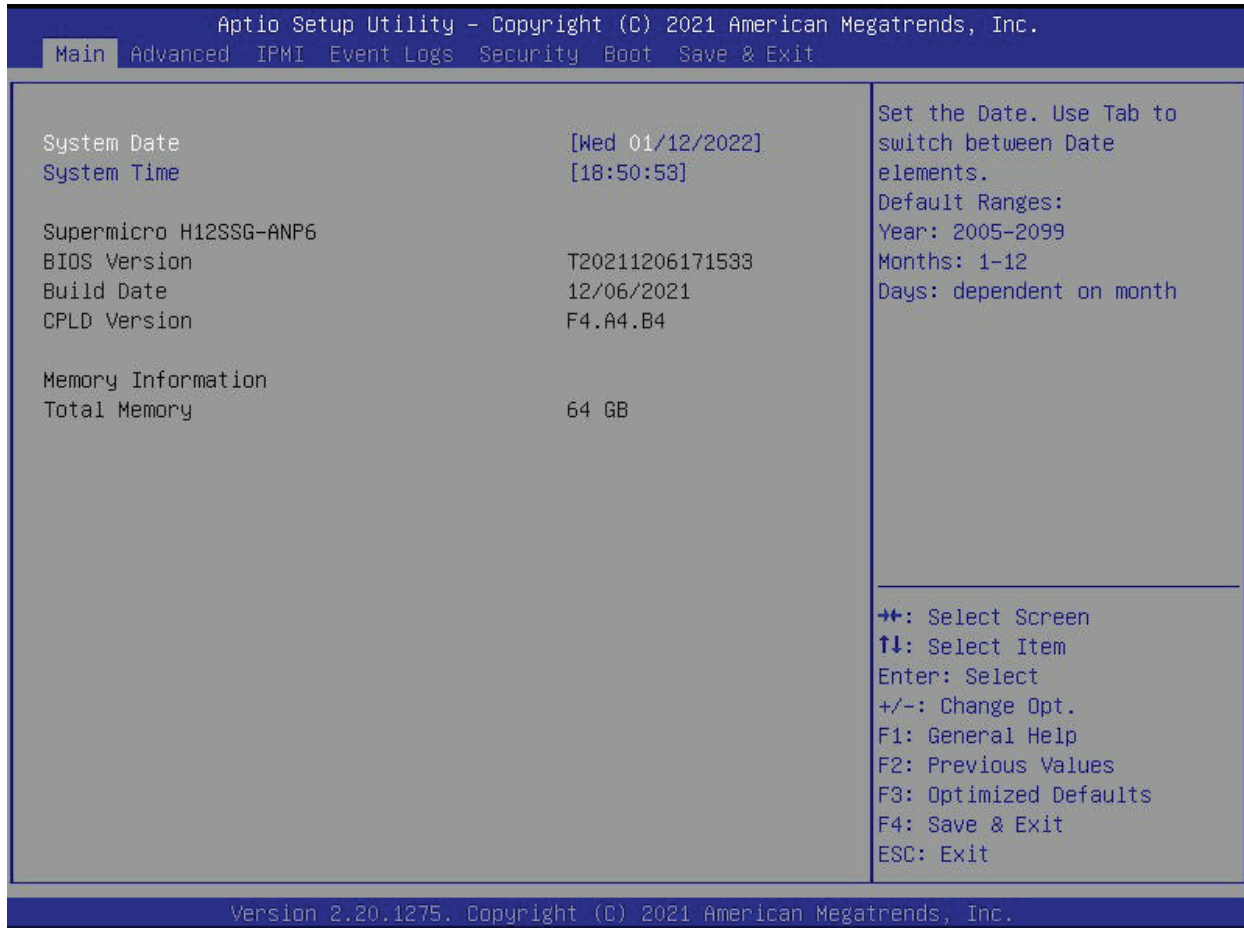

System Date/System Time

Use this option to change the system date and time. Highlight *System Date* or *System Time* using the arrow keys. Enter new values using the keyboard. Press the <Tab> key or the arrow keys to move between fields. The date must be entered in MM/DD/YYYY format. The time is entered in HH:MM:SS format.

Note: The time is in the 24-hour format. For example, 5:30 P.M. appears as 17:30:00. The date's default value is 01/01/2015 after RTC reset.

Supermicro H12SSG-ANP6

BIOS Version

This item displays the version of the BIOS ROM used in the system.

Build Date

This item displays the date when the version of the BIOS ROM used in the system was built.

CPLD Version

This item displays the CPLD version of the BIOS ROM used in the system.

Memory Information

Total Memory

This item displays the total size of memory available in the system.

5.3 Advanced

Use the arrow keys to select Boot Setup and press <Enter> to access the submenu items.

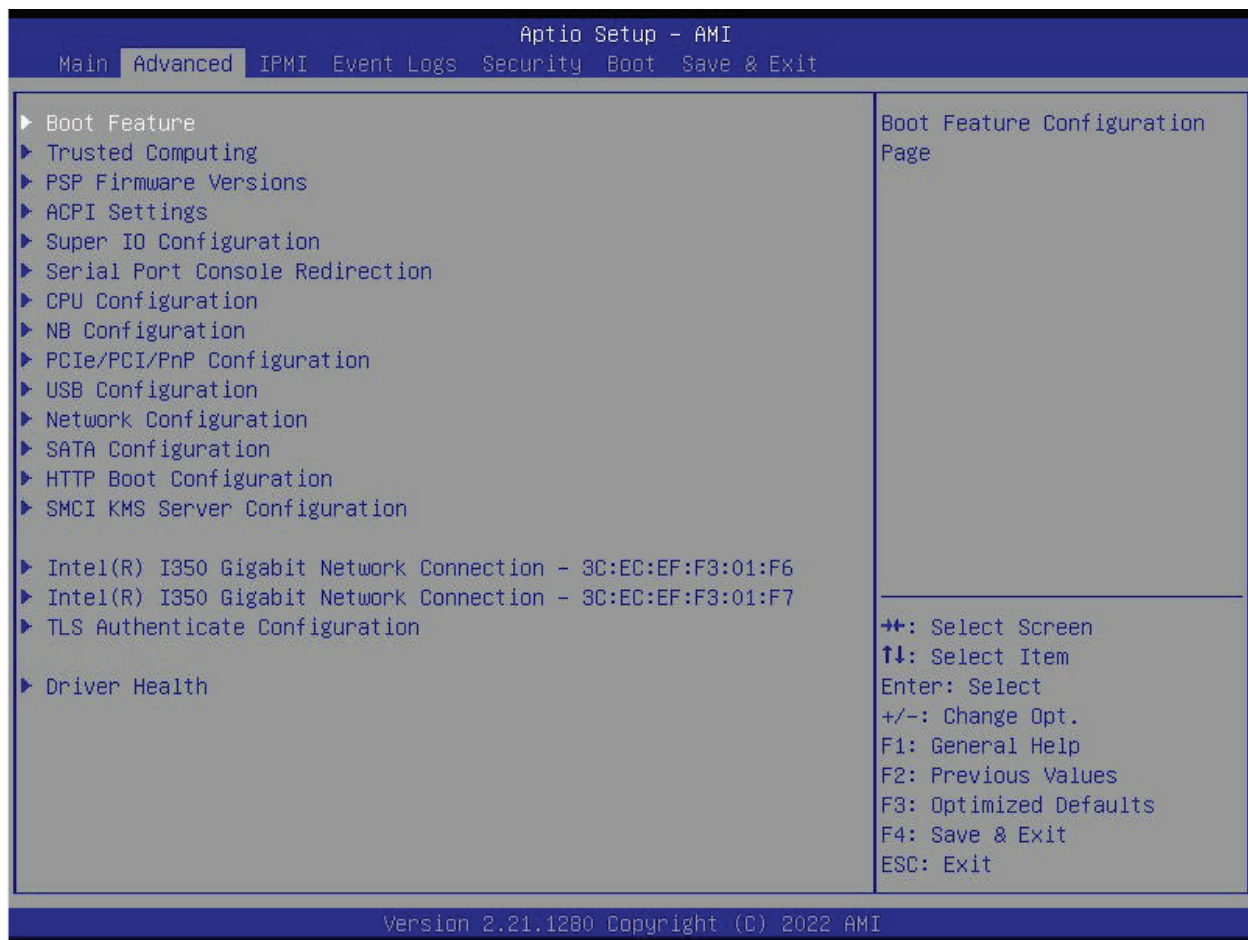

Warning: Take caution when changing the Advanced settings. An incorrect value, a very high DRAM frequency, or an incorrect DRAM timing setting may make the system unstable. When this occurs, revert to the manufacture default settings.

► Boot Feature

Quiet Boot

Use this feature to select the screen display between the POST messages and the OEM logo upon bootup. Select Disabled to display the POST messages. Select Enabled to display the OEM logo instead of the normal POST messages. The options are Disabled and **Enabled**.

Option ROM Messages

Use this feature to set the display mode for the Option ROM. Select Keep Current to display the current AddOn ROM setting. Select Force BIOS to use the Option ROM display set by the system BIOS. The options are **Force BIOS** and Keep Current.

Bootup NumLock State

Use this feature to set the Power on state for the <Numlock> key. The options are **On** and Off.

Wait For "F1" If Error

Use this feature to force the system to wait until the 'F1' key is pressed if an error occurs. The options are Disabled and **Enabled**.

INT19 (Interrupt 19) Trap Response

Interrupt 19 is the software interrupt that handles the boot disk function. When this item is set to Immediate, the ROM BIOS of the host adaptors will "capture" Interrupt 19 at bootup immediately and allow the drives that are attached to these host adaptors to function as bootable disks. If this item is set to Postponed, the ROM BIOS of the host adaptors will not capture Interrupt 19 immediately and allow the drives attached to these adaptors to function as bootable devices at bootup. The options are **Immediate** and Postponed.

Re-try Boot

If this item is enabled, the BIOS will automatically reboot the system from a specified boot device after its initial boot failure. The options are **Disabled**, Legacy Boot, and EFI Boot.

Power Configuration**Watch Dog Function**

If enabled, the Watch Dog Timer will allow the system to reset or generate NMI based on jumper settings when it is expired for more than 5 minutes. The options are **Disabled** and Enabled.

Restore on AC Power Loss

Use this feature to set the power state after a power outage. Select Stay-Off for the system power to remain off after a power loss. Select Power-On for the system power to be turned on after a power loss. Select Last State to allow the system to resume its last power state before a power loss. The options are Stay Off, Power On, and **Last State**.

Power Button Function

This feature controls how the system shuts down when the power button is pressed. Select 4 Seconds Override for the user to power off the system after pressing and holding the power button for 4 seconds or longer. Select Instant Off to instantly power off the system as soon as the user presses the power button. The options are **Instant Off** and 4 Seconds Override.

► Trusted Computing**Configuration**

Security Device Support

Enables or disables BIOS support for security device. OS will not show Security Device. TCG EFI protocol and INT1A interface will not be available. The options are **Disabled** and Enabled.

NO Security Device Found

►PSP Firmware Versions

This section displays the Platform Security Processor (PSP) firmware versions.

PSP Directory Level 1 (Fixed)

- PSP Recovery BL Ver
- SUM FW Version
- ABL Version

PSP Directory Level 2 (Updateable)

- PSP Bootloader Version
- SUM FW Version
- ABL Version

►ACPI Settings

PCI AER Support

The options are **Disabled** and Enabled.

High Precision Event Timer

The High Precision Event Timer (HPET) can produce periodic interrupts and is used to synchronize multimedia streams, providing smooth playback and reducing the need to use other timestamp calculations. The options are **Enabled** and Disabled.

NUMA Nodes Per Socket

The options are NPS0, NPS1, NPS2, NPS4 and **Auto**.

ACPI SRAT L3 Cache As NUMA Domain

The options are Disabled, Enabled and **Auto**.

►Super IO Configuration

The following Super IO information will display:

- Super IO Chip AST2600

► Serial Port 1 Configuration

Serial Port

Select Enabled to enable the selected onboard serial port. The options are Disabled and Enabled.

Device Settings

This item displays the status of a serial part specified by the user.

Change Settings

This feature specifies the base I/O port address and the Interrupt Request address of a serial port specified by the user. Select Auto to allow the BIOS to automatically assign the base I/O and IRQ address. The options are **Auto**, (IO=3F8h; IRQ=4;); (IO=3F8h; IRQ=3, 4, 5, 6, 7, 9, 10, 11, 12;); (IO=2F8h; IRQ=3, 4, 5, 6, 7, 9, 10, 11, 12;); (IO=3E8h; IRQ=3, 4, 5, 6, 7, 9, 10, 11, 12;); and (IO=2E8h; IRQ=3, 4, 5, 6, 7, 9, 10, 11, 12;).

► SOL Configuration

Serial Port

Select Enabled to enable the selected onboard serial port. The options are Disabled and Enabled.

Device Settings

This item displays the status of a serial part specified by the user.

Change SOL Settings

This feature specifies the base I/O port address and the Interrupt Request address of a serial port specified by the user. Select Auto to allow the BIOS to automatically assign the base I/O and IRQ address. The options are **Auto**, (IO=2F8h; IRQ=3;); (IO=3F8h; IRQ=3, 4, 5, 6, 7, 9, 10, 11, 12;); (IO=2F8h; IRQ=3, 4, 5, 6, 7, 9, 10, 11, 12;); (IO=3E8h; IRQ=3, 4, 5, 6, 7, 9, 10, 11, 12;); and (IO=2E8h; IRQ=3, 4, 5, 6, 7, 9, 10, 11, 12;)

► Serial Port Console Redirection

COM1

Console Redirection

Select Enabled to enable console redirection support for a serial port specified by the user. The options are Enabled and **Disabled**.

****If the item above set to Enabled, the following items will become available for user's configuration:***

► Console Redirection Settings

SOL

Console Redirection

Select Enabled to enable SOL console redirection support for a serial port specified by the user. The options are **Enabled** and Disabled.

**If the item above set to Enabled, the following items will become available for user's configuration:*

► Console Redirection Settings

Terminal Type

This feature allows the user to select the target terminal emulation type for Console Redirection. Select VT100 to use the ASCII Character set. Select VT100+ to add color and function key support. Select ANSI to use the Extended ASCII Character Set. Select VT-UTF8 to use UTF8 encoding to map Unicode characters into one or more bytes. The options are VT100, **VT100+**, VT-UTF8, and ANSI.

Bits per second

Use this feature to set the transmission speed for a serial port used in Console Redirection. Make sure that the same speed is used in the host computer and the client computer. A lower transmission speed may be required for long and busy lines. The options are 9600, 19200, 38400, 57600 and **115200** (bits per second).

Data Bits

Use this feature to set the data transmission size for Console Redirection. The options are 7 and 8.

Parity

A parity bit can be sent along with regular data bits to detect data transmission errors. Select Even if the parity bit is set to 0, and the number of 1's in data bits is even. Select Odd if the parity bit is set to 0, and the number of 1's in data bits is odd. Select None if you do not want to send a parity bit with your data bits in transmission. Select Mark to add a mark as a parity bit to be sent along with the data bits. Select Space to add a Space as a parity bit to be sent with your data bits. The options are **None**, Even, Odd, Mark, and Space.

Stop Bits

A stop bit indicates the end of a serial data packet. Select 1 Stop Bit for standard serial data communication. Select 2 Stop Bits if slower devices are used. The options are 1 and 2.

Flow Control

Use this feature to set the flow control for Console Redirection to prevent data loss caused by buffer overflow. Send a "Stop" signal to stop sending data when the receiving buffer is full. Send a "Start" signal to start sending data when the receiving buffer is empty. The options are **None** and Hardware RTS/CTS.

VT-UTF8 Combo Key Support

Select Enabled to enable VT-UTF8 Combination Key support for ANSI/VT100 terminals. The options are Disabled and **Enabled**.

Recorder Mode

Select Enabled to capture the data displayed on a terminal and send it as text messages to a remote server. The options are **Disabled** and Enabled.

Legacy OS Redirection Resolution

Select the screen resolution when the legacy operating system is being redirected. The options are 80x24 and **80x25**.

Resolution 100x31

Select Enabled for extended-terminal resolution support. The options are Disabled and **Enabled**.

Putty KeyPad

This feature selects the settings for Function Keys and KeyPad used for Putty, which is a terminal emulator designed for the Windows OS. The options are **VT100**, LINUX, XTERMR6, SC0, ESCN, and VT400.

Redirection After BIOS POST

Select Always Enable to redirect the console before booting the legacy operating system. Select Bootloader to disable console redirection. The options are **Always Enable** and Bootloader.

Legacy Console Redirection

Legacy Serial Redirection Port

For this setting, select a COM port to display redirection of Legacy OS and Legacy OPROM messages. Options include **COM1** and SOL.

Serial Port for Out-of-Band Management / Windows Emergency Management Services (EMS)

Console Redirection

Select Enabled to enable EMS console redirection support for a serial port specified by the user. The options are Enabled and **Disabled**.

**If the item above set to Enabled, the following items will become available for user's configuration:*

► CPU Configuration

SMT Control

Use this setting to disable symmetric multithreading. Options include Disabled and **Auto**.

Core Performance Boost

This setting is used to configure for Core Performance Boost. Options include **Auto** and Disabled.

Global C-state Control

This setting is used to configure for Global C-state Control. Options include Disabled, Enabled, and **Auto**.

Local APIC Mode

Options include Compatibility, xAPIC, x2APIC, and **Auto**.

CCD Control

Sets the number of CCDs to be used. Once this option has been used to remove any CCDs, a POWER CYCLE is required in order for future selections to take effect. Options include **Auto**, 2 CCDs, 3 CCDs, 4 CCDs, and 6 CCDs.

Core Control

Sets the number of cores to be used. Once this option has been used to remove any CCDs, a POWER CYCLE is required in order for future selections to take effect. Options include **Auto**, ONE (1+0), TWO (2+0), THREE (3+0), FOUR (4+0), FIVE (5+0), SIX (6+0), and SEVEN (7+0).

L1 Stream HW Prefetcher / L2 Stream HW Prefetcher

This setting is used to enable or disable the L1/L2 Stream Hardware Prefetcher. The options are Disabled, Enabled, and **Auto**.

SEV ASID Count

This field specifies the maximum valid ASID, which affects the maximum system physical address space. The options are 253 ASIDs, 509 ASIDs, and **Auto**.

SEV-ES ASID Space Limit Control

Auto or Manual to control SEV-ES ASID Space Limit. The options are **Auto** and Manual.

SVM Mode

This setting **Enables** or Disables CPU Virtualization.

► CPU1 Information

These sections are for informational purposes. They will display some details about the detected CPUs on the motherboard, such as:

- CPU Version
- Number of Cores Running
- Processor Family
- Processor Model
- Microcode Patch Level
- L1 Instruction Cache (Size/Method)
- L1 Data Cache (Size/Method)
- L2 Data Cache (Size/Method)
- L3 Cache per Scket (Size/Method)

► NB Configuration

Determinism Control

Use this setting to configure the Determinism Slider. Options include Manual and **Auto**.

cTDP Control

Use this setting to configure the cTDP Control. Options include **Auto** and Manual.

IOMMU

Use this setting to enable or disable IOMMU. Options include Disabled, Enabled, and **Auto**.

SEV-SNP Support

Use this setting to enable or disable SEV-SNP support. Options include **Disabled** and Enabled.

Package Power Limit Control

Set to **Auto** to use the fused PPT or Manual to allow the user to set a customized PPT.

APBDIS

Use this setting to . Options include 0, 1, and **Auto**.

DF Cstates

Options include Disabled, Enabled, and **Auto**.

Preferred IO

Options include Manual and **Auto**.

► LCLK Frequency Control

Root Complex 0x00 LCLK Frequency

Set the Root Complex LCLK frequency. Options include **Auto** and 593MHz.

Root Complex 0x40 LCLK Frequency

Set the Root Complex LCLK frequency. Options include **Auto** and 593MHz.

Root Complex 0x80 LCLK Frequency

Set the Root Complex LCLK frequency. Options include **Auto** and 593MHz.

Root Complex 0xC0 LCLK Frequency

Set the Root Complex LCLK frequency. Options include **Auto** and 593MHz.

EDC Control

Set the Electrical Design Current (EDC), the total current in Amps that can be supplied to the socket. The options include Manual and **Auto**.

► Memory Configuration

Memory Clock

This setting allows you to select different memory clock speed. Options include **Auto**, 2667 MHz, 2933 MHz, and 3200 MHz.

Memory interleaving

This setting controls fabric level memory interleaving. Note that the channel, die and socket have requirements on memory populations and it will be ignored if the memory doesn't support the selected option. Options include Disabled and **Auto**.

Memory interleaving size

This setting controls the memory interleaving size. This determines the starting address of the interleave (bit 8, 9, 10 or 11). Options include 256 Bytes, 512 Bytes, 1 KB, 2 KB, 4 KB, and **Auto**.

Chipset Interleaving

This setting controls interleave memory blocks across the DRAM chip for node 0. Options include Disabled and **Auto**.

BankGroupSwap

This setting controls the Bank Group Swap. Options include Enabled, Disabled and **Auto**

DRAM Scrub Time

This setting provides a value that is the number of hours to scrub memory. Options include Disabled, 1 hour, 4 hours, 8 hours, 16 hours, 24 hours, 48 hours, and **Auto**.

TSME

Use this setting to enable or disable TSME. Options include Disabled, Enabled, and **Auto**.

DDR Power Down Enable

Use this setting to control DDR Power Down Enable. Options include Disabled, Enabled, and **Auto**.

► CPU1 Memory Information

Provides information on CPU1 DIMMs.

► PCIe/PCI/PnP Configuration

This menu provides PCIe/PCI/PnP configuration settings and information.

PCI Bus Driver Version

PCI Devices Common Settings:

Above 4G Decoding

This setting **Enables** or Disables 64-bit capable devices ability to be decoded in above 4G address space (only if the system supports 64-bit PCI decoding).

SR-IOV Support

If the system has SR-IOV capable PCI-E devices, this setting will Enable or **Disable** the Single Root IO Virtualization Support for the system.

BME DMA Mitigation

Use this setting to re-enable the Bus Master Attribute that was disabled during PCI enumeration for PCI bridges after SMM is locked. The options are **Disabled** and Enabled.

PCIe ARI Support

Use this setting to enable or disable Alternative Routing-ID Interpretation. The options are Disabled, Enabled and **Auto**.

PCIe Ten Bit Tag Support

Use this setting to enable PCIe ten bit tags for supported devices. The options are Disabled, Enabled and **Auto**.

PCIe Spread Spectrum

Use this setting to Enable or **Disable** PCIe Spread Spectrum for your system.

Relaxed Ordering

Use this setting to Enable or **Disable** PCI Express Device Relaxed Ordering.

No Snoop

Use this setting to **Enable** or Disable PCI Express Device No Snoop option.

VGA Priority

Use this setting to select between onboard or offboard VGA support. The options are **Onboard** and Offboard.

NVMe Firmware Source

Use this setting to select between the AMI Native firmware support or the device vendor-defined firmware support. The options are AMI Native Support and **Vendor Defined Firmware**.

M.2 (AHCI) Firmware Source

Use this setting to select between the AMI Native firmware support or the device vendor-defined firmware support. The options are AMI Native Support and **Vendor Defined Firmware**.

JM2_A1 OPROM

Use this setting to enable or disable the JM2_A1 OPROM option. The options are Disabled and **EFI**.

AIOM OPROM

Use this setting to enable or disable the AIOM OPROM option. The options are Disabled and **EFI**.

JM2_B1 OPROM

Use this setting to enable or disable the JM2_B1 OPROM option. The options are Disabled and **EFI**.

RSC-GF-66G4 Slot1 PCI-E 4.0 x16 OPROM

Use this setting to enable or disable PCI/PCIX/PCIe slot 6. The options are Disabled and **EFI**.

RSC-GF-66G4 Slot2 PCI-E 4.0 x16 OPROM

Use this setting to enable or disable PCI/PCIX/PCIe slot 6. The options are Disabled and **EFI**.

RSC-GB-66G4 Slot1 PCI-E 4.0 x16 OPROM

Use this setting to enable or disable PCI/PCIX/PCIe slot 6. The options are Disabled and **EFI**.

RSC-GB-66G4 Slot2 PCI-E 4.0 x16 OPROM

Use this setting to enable or disable PCI/PCIX/PCIe slot 6. The options are Disabled and **EFI**.

RSC-GFR-66G4 Slot1 PCI-E 4.0 x16 OPROM

Use this setting to enable or disable PCI/PCIX/PCIe slot 6. The options are Disabled and **EFI**.

Onboard NVMe1 Option ROM

Use this setting to select which firmware is loaded for onboard NVMe1. The options are Disabled and **EFI**.

Onboard NVMe2 Option ROM

Use this setting to select which firmware is loaded for onboard NVMe2. Options include Disabled and **EFI**.

► USB Configuration**Legacy USB Support**

Use this setting to enable USB legacy support. Auto disabled support if no USB devices are connected. Disable will keep USB devices available only for EFI applications Options are **Enabled**, Disabled, and Auto.

XHCI Hand-off

Workaround for OS's without XHCI support. The XHCI ownership change should be claimed by the XHCI driver. Options are **Enabled** and Disabled.

Port 60/64 Emulation

Enables I/O port 60h/64h emulation support. This should be enabled for complete USB keyboard legacy support for non-USB aware OS's. Options are **Enabled** and Disabled.

► Network Configuration**Network Stack**

This setting allows you to **Enable** or Disable the UEFI Network Stack.

IPv4 PXE Support

This setting allows you to **Enable** or Disable IPv4 PXE boot support. If disabled, IPv4 PXE boot support will not be available.

IPv4 HTTP Support

This setting allows you to Enable or **Disable** IPv4 HTTP boot support. If disabled, IPv4 HTTP boot support will not be available.

IPv6 PXE Support

This setting allows you to **Enable** or Disable IPv6 PXE boot support. If disabled, IPv6 PXE boot support will not be available.

IPv6 HTTP Support

This setting allows you to Enable or **Disable** IPv6 HTTP boot support. If disabled, IPv6 HTTP boot support will not be available.

PXE Boot Wait Time

This setting allows you to set in a number field the wait time to press the ESC key to abort the PXE boot. Default is **0**.

Media Detect Count

This setting allows you set in a number field the number of times presence of media will be checked. Default is **1**.

▶MAC:3CECEFF301F6 - IPv4 Network Configuration

Use this setting to view IPv4 network configuration.

▶MAC:3CECEFF301F6 - IPv6 Network Configuration

Use this setting to view IPv6 network configuration.

▶MAC:3CECEFF301F7 - IPv4 Network Configuration

Use this setting to view IPv4 network configuration.

▶MAC:3CECEFF301F7 - IPv6 Network Configuration

Use this setting to view IPv6 network configuration.

▶SATA Configuration

SATA Information

SATA Enable

Use this setting to disable or enable OnChip SATA controller. Options are Disabled, Enabled, and **Auto**.

SATA Hotplug

Use this setting to disable or enable OnChip SATA Hotplug function. Options are Disabled and **Enabled**.

▶ **SATA Information**

Use this setting to view SATA devices information.

▶ **HTTP Boot Configuration**

HTTP Boot Configuration

HTTP Boot Policy

Sets the HTTP boot policy to Apply to all LANs, **Apply to each LAN**, and Boot Priority #1 instantly.

HTTPS Boot Checks Hostname

This feature checks if the hostname of the TLS certificates matches the hostname provided by the remote server. The options are **Enabled** and Disabled (WARNING: Security Risk!!).

Priority of HTTP Boot

Instance of Priority 1

Default to 1.

Select IPv4 of IPv6

Choose to set the targeted LAN port to boot from **IPv4** or IPv6.

Boot Description

Must be filled out, otherwise boot option for the URI will not be created. Length of description cannot exceed 75 characters.

Boot URI

This option is an input field used to enter a web or network address to point to the HTTP boot files. This supports the HTTP or HTTPS protocols only.

▶ **SMCI KMS Server Configuration**

SMCI KMS Server IP address

Second SMCI KMS Server IP address

SMCI KMS TCP Port Number

SMCI KMS Server Retry Count

TimeZone

TCG NVMe KMS Policy

NVMe device lock policy. Options include Normal Unlock, Reset All Devices, Delete Key Id List, **Do Nothing**.

Client UserName

Enter Client Username, cannot exceed 31 characters.

ClientPassword

Enter Client Password, cannot exceed 31 characters.

KMS TLS Certificate | Size**▶ CA Certificate | 0**

Enroll factory defaults or load the KMS TLS certificates from the file. Options include **Update**, Delete, and Export.

▶ Client Certificate | 0

Enroll factory defaults or load the KMS TLS certificates from the file. Options include **Update**, Delete, and Export.

▶ Client Private Key | 0

Enroll factory defaults or load the KMS TLS certificates from the file. Options include **Update**, Delete, and Export.

▶ Intel(R) I350 Gigabit Network Connection - 3C:EC:EF:F3:01:F6**Port Configuration Menu****▶ NIC Configuration****Link Speed**

Select the link speed and duplex for current port. The options are **AutoNeg**, 10 Mbps Half, 10 Mbps Full, 100 Mbps Half, and 100 Mbps Full.

Wake on LAN

This feature wakes up the system with a magic packet. The options are Disabled and Enabled.

Blink LEDs (range 0-15 seconds)

Set to blink LEDs for the specifies duration (uo to 15 seconds).

Port Configuration Information

UEFI Driver

Adapter PBA

Chip Type

PCI Device ID

PCI Bus:Device:Function:

Link Status

Factory MAC Address

Alternate MAC Address

▶ Intel(R) I350 Gigabit Network Connection - 3C:EC:EF:F3:01:F7

Port Configuration Menu

▶ NIC Configuration

Link Speed

Select the link speed and duplex for current port. The options are **AutoNeg**, 10 Mbps Half, 10 Mbps Full, 100 Mbps Half, and 100 Mbps Full.

Wake on LAN

This feature wakes up the system with a magic packet. The options are Disabled and Enabled.

Blink LEDs (range 0-15 seconds)

Set to blink LEDs for the specifies duration (up to 15 seconds).

Port Configuration Information

UEFI Driver

Adapter PBA

Chip Type

PCI Device ID

PCI Bus:Device:Function:

Link Status

Factory MAC Address

Alternate MAC Address

▶ TLS Authenticate Configuration

This submenu allows the user to configure Transport Layer Security (TLS) settings.

▶ Server CA Configuration

▶ Enroll Certification

▶ Enroll Certification Using File

Use this feature to enroll certification from a file.

Certification GUID

Use this feature to input the certification GUID.

▶ Commit Changes and Exit

Use this feature to save all changes and exit TLS settings.

▶ Discard Changes and Exit

Use this feature to discard all changes and exit TLS settings.

▶ Delete Certification

Use this feature to delete certification. The options include **Disabled** and Enabled.

▶ Driver Health

▶ Intel 10GbE Driver 5.8.06 x64

This provides the health status for the drivers and controllers.

5.4 IPMI

This tab allows you to configure the following IPMI settings for the system.



Use this feature to configure Intelligent Platform Management Interface (IPMI) settings.

BMC Firmware Revision

This item indicates the IPMI firmware revision used in your system.

IPMI Status

This item indicates the status of the IPMI firmware installed in your system.

► System Event Log

Enabling/Disabling Options

SEL Components

Select Enabled for all system event logging at bootup. The options are Disabled and Enabled.

Erasing Settings

Erase SEL

Select Yes, On next reset to erase all system event logs upon next system reboot. Select Yes, On every reset to erase all system event logs upon each system reboot. Select No to keep all system event logs after each system reboot. The options are **No**, Yes, On next reset, and Yes, On every reset.

When SEL is Full

This feature allows the user to decide what the BIOS should do when the system event log is full. Select Erase Immediately to erase all events in the log when the system event log is full. The options are **Do Nothing** and Erase Immediately.

Note: After making changes on a setting, be sure to reboot the system for the changes to take effect.

► BMC Network Configuration**BMC Network Configuration****Configure IPV4/IPV6 Support**

This section displays static configuration features for IPV4 support.

IPMI LAN Selection

This item displays the IPMI LAN setting. The default setting is **Failover**.

IPMI Network Link Status

This item displays the IPMI Network Link status. The default setting is **Shared LAN**.

Configuration Address Source

This feature allows the user to select the source of the IP address for this computer. If Static is selected, you will need to know the IP address of this computer and enter it to the system manually in the field. If DHCP is selected, the BIOS will search for a DHCP (Dynamic Host Configuration Protocol) server in the network that is attached to and request the next available IP address for this computer. The options are **DHCP** and Static.

****If the item above is set to Static, the following items will become available for configuration:***

Station IP Address

This item displays the Station IP address for this computer. This should be in decimal and in dotted quad form.

Subnet Mask

This item displays the Subnet Mask for this computer. This should be in decimal and in dotted quad form.

Station MAC Address

This item displays the Station MAC address for this computer. This should be in decimal and in dotted quad form.

Gateway IP Address

This item displays the Gateway IP address for this computer. This should be in decimal and in dotted quad form (i.e., 172.31.0.1).

VLAN

This item displays the virtual LAN settings. The options are **Disabled** and Enabled.

5.5 Event Logs

This tab allows the user to configure the following event logs settings for the system.

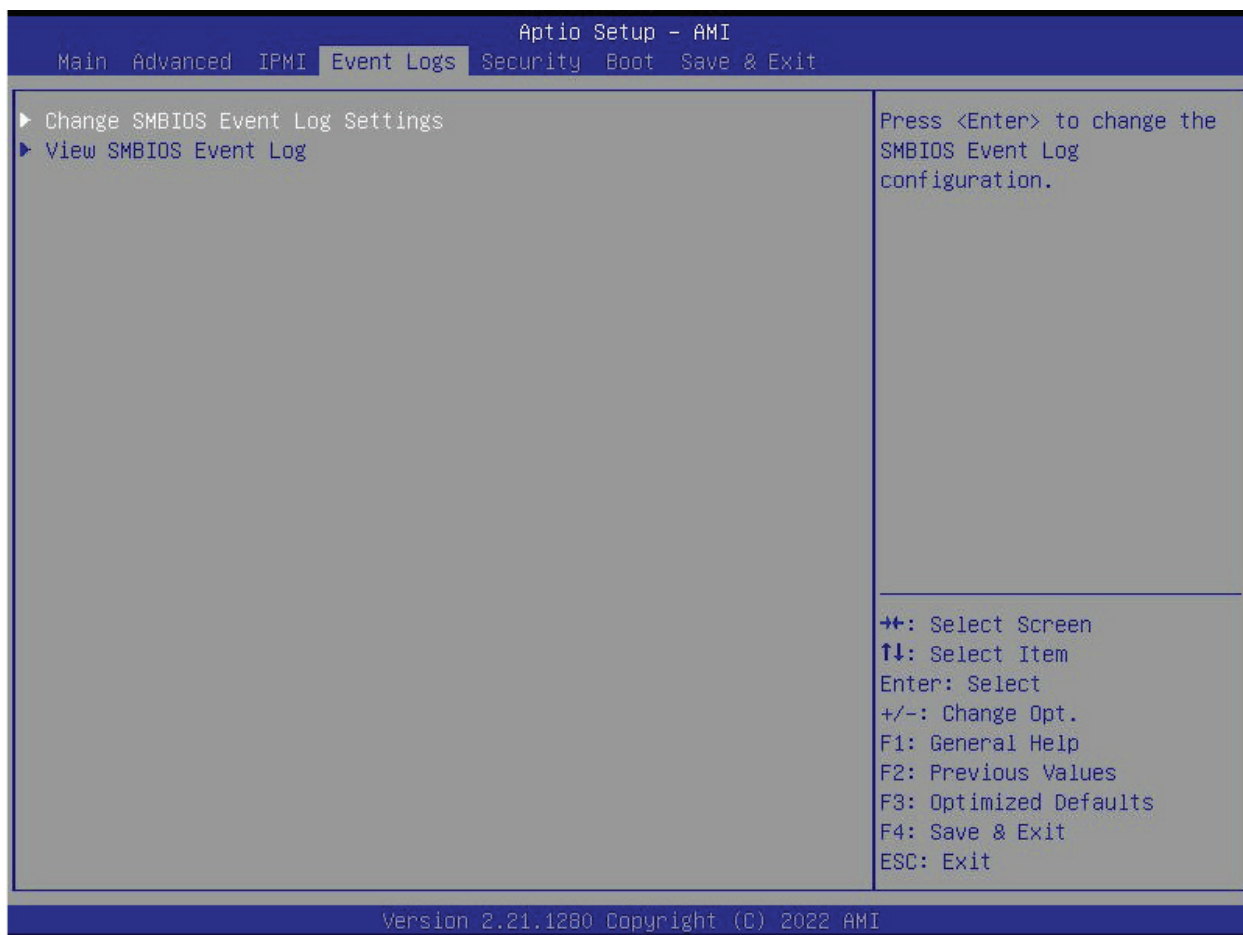

► Change SMBIOS Event Log Settings

This feature allows the user to configure SMBIOS Event settings.

Enabling/Disabling Options

SMBIOS Event Log

Select Enabled to enable SMBIOS (System Management BIOS) Event Logging during system boot. The options are Disabled and **Enabled**.

Erasing Settings

Erase Event Log

Select Yes to erase all error events in the SMBIOS (System Management BIOS) log before an event logging is initialized at bootup. The options are **No**, Yes, Next reset, and Yes, every reset.

When Log is Full

Select Erase Immediately to immediately erase all errors in the SMBIOS event log when the event log is full. Select Do Nothing for the system to do nothing when the SMBIOS event log is full. The options are **Do Nothing** and Erase Immediately.

SMBIOS Event Log Standard Settings

Log System Boot Event

Select Enabled to log system boot events. The options are Enabled and **Disabled**.

MECI (Multiple Event Count Increment)

Enter the increment value for the multiple event counter. Enter a number between 1 to 255. The default setting is **1**.

METW (Multiple Event Count Time Window)

This item is used to determine how long (in minutes) the multiple event counter should wait before generating a new event log. Enter a number between 0 to 99. The default setting is **60**.

Note: Please reboot the system for these changes to take effect.

►View SMBIOS Event Log

When Event Logging is on, this item allows the user to view the entries in the SMBIOS event log. The following categories are displayed:

Date/Time/Error Code/Severity

5.6 Security

This tab allows you to configure the following security settings for the system.

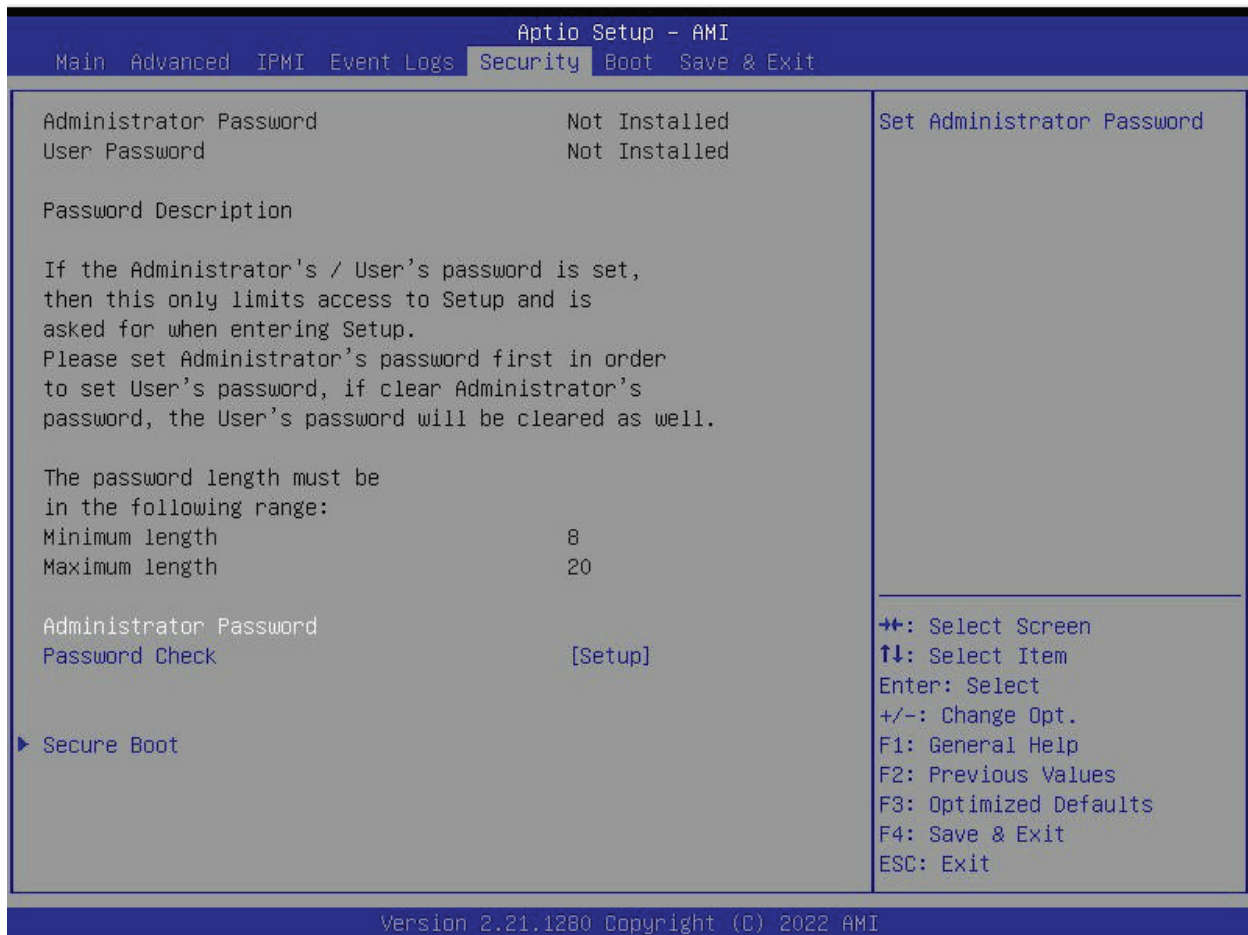

Administrator Password

Press Enter to create a new, or change an existing Administrator password. Note that if the Administrator Password is erased, the User Password will be cleared as well.

User Password

Press Enter to create a new, or change an existing User password.

Administrator Password

Press Enter to set the administrator password.

Password Check

Select Setup for the system to check for a password at Setup. Select Always for the system to check for a password at bootup or upon entering the BIOS Setup utility. The options are **Setup** and **Always**.

► Secure Boot

This section contains options and menus for securing your boot mode and for key management.

Secure Boot

This option allows you specify when the Platform Key (PK) is enrolled. When enabled, the System Mode is user deployed, and the CSM function is disabled. Options include Enabled and **Disabled**.

Secure Boot Mode

Use this item to select the secure boot mode. The options are Standard and **Custom**.

CSM Support

Select Enabled to support the EFI Compatibility Support Module (CSM), which provides compatibility support for traditional legacy BIOS for system boot. The options are Disabled and **Enabled**.

► Key Management

This submenu allows the user to configure the following Key Management settings.

Vendor Keys

Provision Factory Defaults

Select Enabled to install the default Secure-Boot keys set by the manufacturer. The options are Disabled and Enabled. The options include Disabled and **Enabled**.

► Restore Factory Keys

Select Yes to install all default secure keys set by the manufacturer. The options are **Yes** and No.

► Reset To Setup Mode

► Export Secure Boot variables

► Enroll EFI Image

This allows the image to run in Secure Boot Mode, and enroll SHA256 hash of the binary into an Authorized Signature Database (db).

Device Guard Ready

► Remove 'UEFI CA' from DB

► Restore DB defaults

The options are **Yes** and No.

Secure Boot Variable

This feature allows you to decide if all secure boot variables should be saved.

▶Platform Key (PK)

This feature allows you to configure the settings of the platform keys.

Set New Key

Select Yes to load the new platform keys (PK) from the manufacturer's defaults. Select No to load the platform keys from a file. The options are **Yes** and No.

Provision Factory Default Keys

Select Enabled to install the default Secure-Boot keys set by the manufacturer. The options are **Disabled** and Enabled.

▶Key Exchange Keys

This feature allows you to configure the settings of the Key Exchange Keys. The options include **Update** and Append.

▶Authorized Signatures

This feature allows you to configure the settings of the Authorized Signatures. The options include **Update** and Append.

▶Forbidden Signatures

This feature allows you to configure the settings of the Forbidden Signatures. The options include **Update** and Append.

▶Authorized TimeStamps

This feature allows you to configure the settings of the authorized TimeStamps. The options include **Update** and Append.

▶OsRecovery Signature

This feature allows you to configure the settings of the authorized OsRecovery Signature. The options include **Update** and Append.

5.7 Boot

Use this tab to configure Boot Settings:

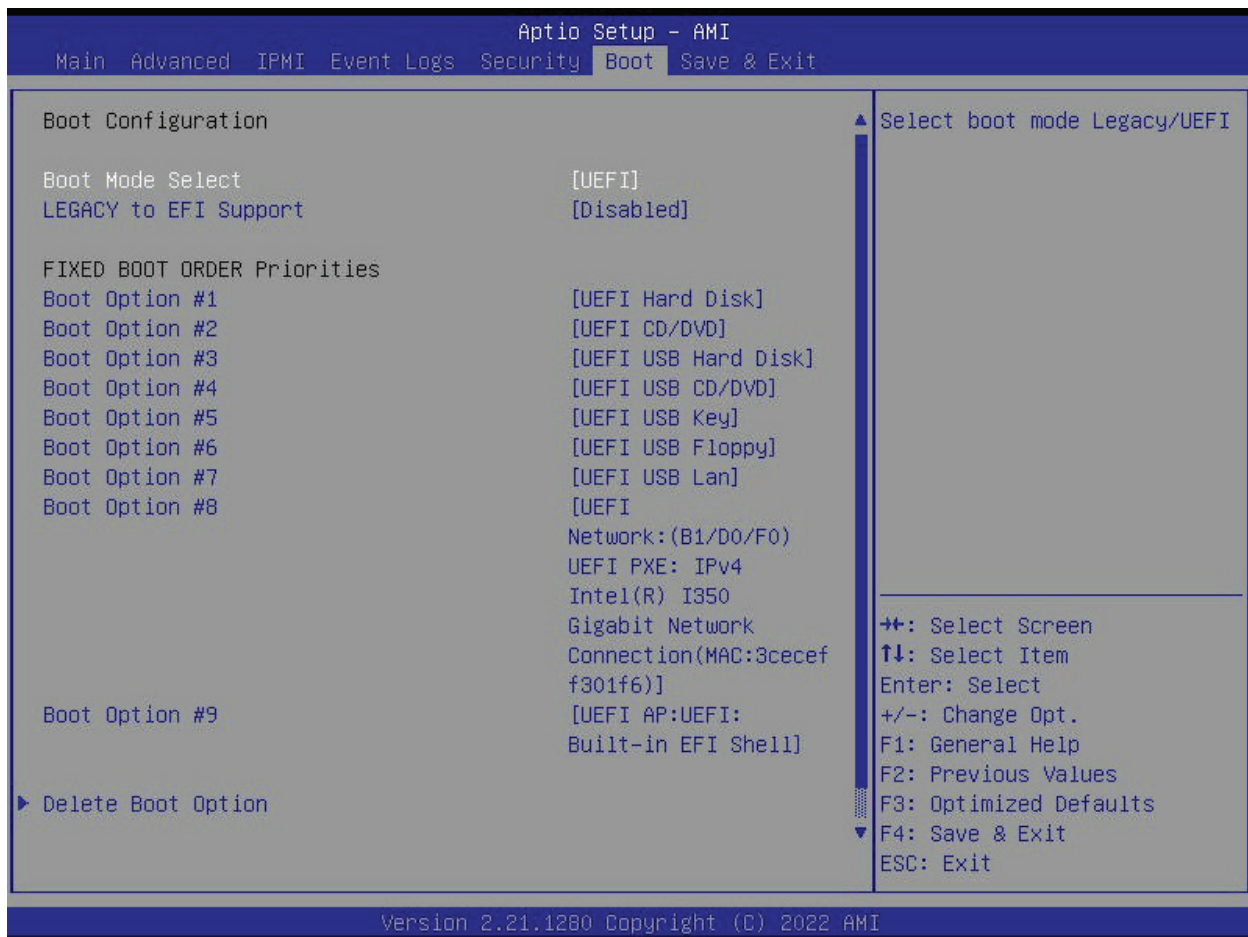

Boot Mode Select

Use this item to select the type of device that the system is going to boot from. The options are Legacy, **UEFI**, and Dual. The default setting is DUAL.

Legacy to EFI Support

This option Enables or **Disables** the system to boot to an EFI OS after the boot failed from the legacy boot order.

FIXED BOOT ORDER Priorities

This option prioritizes the order of bootable devices. Press <Enter> on each entry from top to bottom to select devices.

Boot Option #1

Use this feature to add a boot option to the boot order.

Boot Option #2

Use this feature to add a boot option to the boot order.

Boot Option #3

Use this feature to add a boot option to the boot order.

Boot Option #4

Use this feature to add a boot option to the boot order.

Boot Option #5

Use this feature to add a boot option to the boot order.

Boot Option #6

Use this feature to add a boot option to the boot order.

Boot Option #7

Use this feature to add a boot option to the boot order.

Boot Option #8

Use this feature to add a boot option to the boot order.

Boot Option #9

Use this feature to add a boot option to the boot order.

►Delete Boot Option

Use this feature to remove a pre-defined boot device from which the system will boot during startup. The settings are [any pre-defined boot device].

►UEFI Hard Disk Drive BBS Priorities

This feature allows the user to specify which UEFI devices are boot devices.

- Boot Option #1
- Boot Option #2
- Boot Option #3
- Boot Option #4
- Boot Option #5

►UEFI Network Drive BBS Priorities

This feature specifies the boot device priority sequence from the available UEFI network drives.

- Boot Option #1

► **UEFI Application Boot Priorities**

This feature allows the user to specify which UEFI devices are boot devices.

- Boot Option #1

5.8 Save & Exit

Select the Save & Exit tab to enter the Save & Exit BIOS Setup screen.

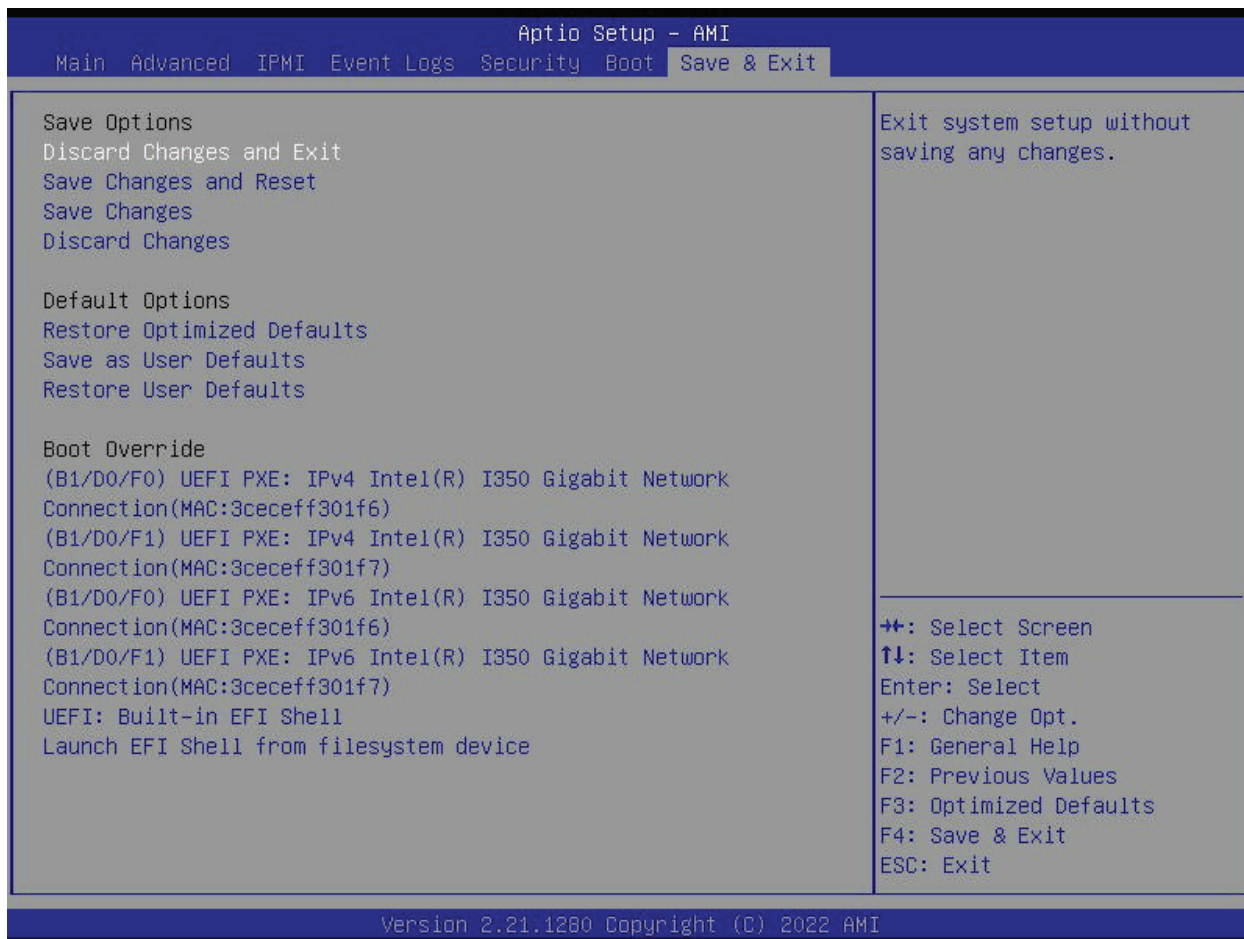

Discard Changes and Exit

Select this option to quit the BIOS Setup without making any permanent changes to the system configuration, and reboot the computer. Select Discard Changes and Exit from the Exit menu and press <Enter>.

Save Changes and Reset

Select this option to reset the system after saving the changes.

Save Changes

After completing the system configuration changes, select this option to save the changes you have made. This will not reset (reboot) the system.

Discard Changes

Select this option and press <Enter> to discard all the changes and return to the AMI BIOS utility Program.

Default Options

Restore Optimized Defaults

To set this feature, select Restore Defaults from the Save & Exit menu and press <Enter>. These are factory settings designed for maximum system stability, but not for maximum performance.

Save as User Defaults

To set this feature, select Save as User Defaults from the Exit menu and press <Enter>. This enables the user to save any changes to the BIOS setup for future use.

Restore User Defaults

To set this feature, select Restore User Defaults from the Exit menu and press <Enter>. Use this feature to retrieve user-defined settings that were saved previously.

Boot Override

Listed on this section are other boot options for the system (i.e., Built-in EFI shell). Select an option and press <Enter>. Your system will boot to the selected boot option.

Launch EFI Shell from filesystem device

Use this feature to launch an EFI Shell application (Shell.efi) from one of the available file system devices.

Appendix A

Software

After the hardware has been installed, you can install the Operating System (OS), configure RAID settings and install the drivers.

A.1 Microsoft Windows OS Installation

If you will be using RAID, you must configure RAID settings before installing the Windows OS and the RAID driver. Refer to the RAID Configuration User Guides posted on our website at www.supermicro.com/support/manuals.

Installing the OS

1. Create a method to access the MS Windows installation ISO file. That might be a USB flash or media drive or the IPMI KVM console.
2. Go to the Supermicro web page for your motherboard and click on "Download the Latest Drivers and Utilities", select the proper driver, and copy it to a USB flash drive.
3. Boot from a bootable device with Windows OS installation. You can see a bootable device list by pressing **F11** during the system startup.

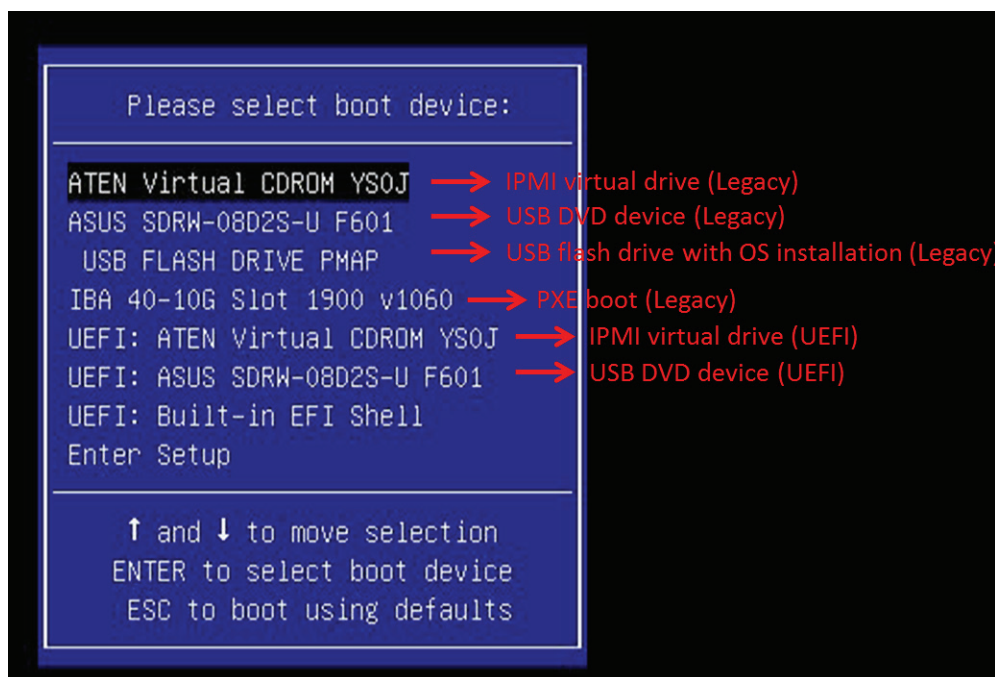

Figure A-1. Select Boot Device

4. During Windows Setup, continue to the dialog where you select the drives on which to install Windows. If the disk you want to use is not listed, click on “Load driver” link at the bottom left corner.

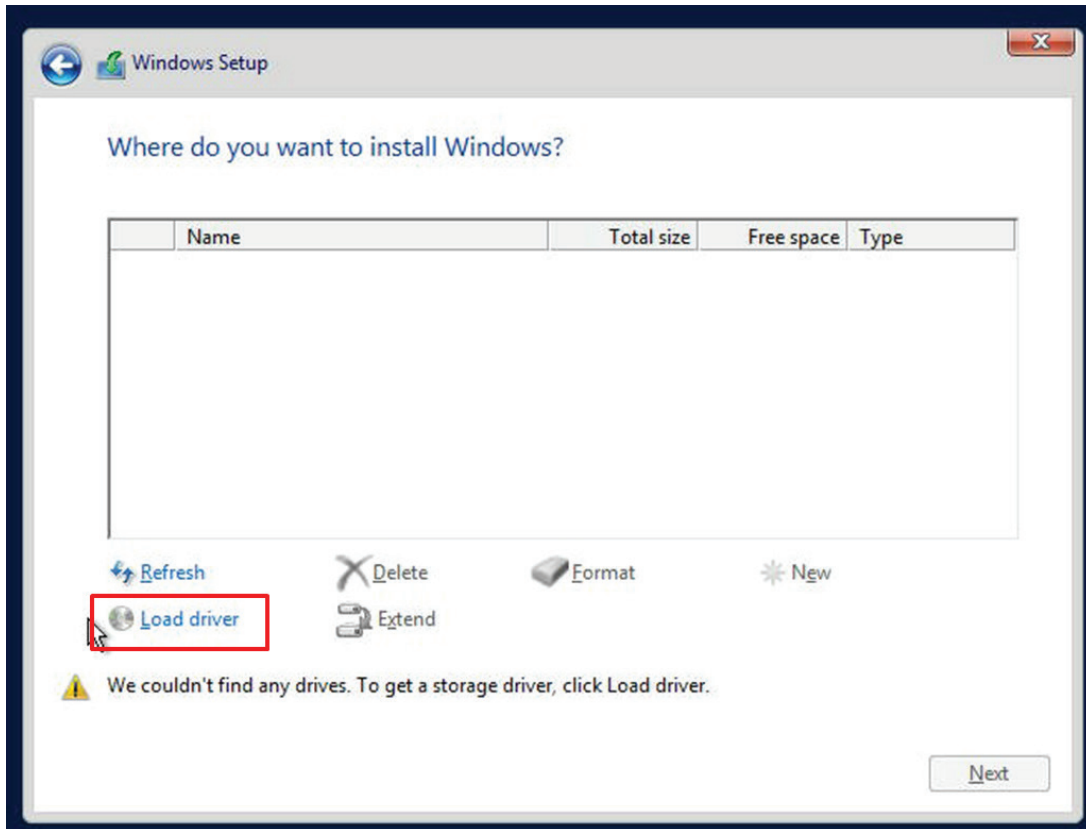

Figure A-2. Load Driver Link

To load the driver, browse the USB flash drive for the proper driver files.

- For RAID, choose the SATA/sSATA RAID driver indicated then choose the storage drive on which you want to install it.
 - For non-RAID, choose the SATA/sSATA AHCI driver indicated then choose the storage drive on which you want to install it.
5. Once all devices are specified, continue with the installation.
 6. After the Windows OS installation has completed, the system will automatically reboot multiple times.

A.2 Driver Installation

The Supermicro website contains drivers and utilities for your system at <https://www.supermicro.com/wdl/driver>. Some of these must be installed, such as the chipset driver.

After accessing the website, go into the CDR_Images (in the parent directory of the above link) and locate the ISO file for your motherboard. Download this file to a USB flash or media drive. (You may also use a utility to extract the ISO file if preferred.)

Another option is to go to the Supermicro website at <http://www.supermicro.com/products/>. Find the product page for your motherboard, and "Download the Latest Drivers and Utilities". Insert the flash drive or disk and the screenshot shown below should appear.

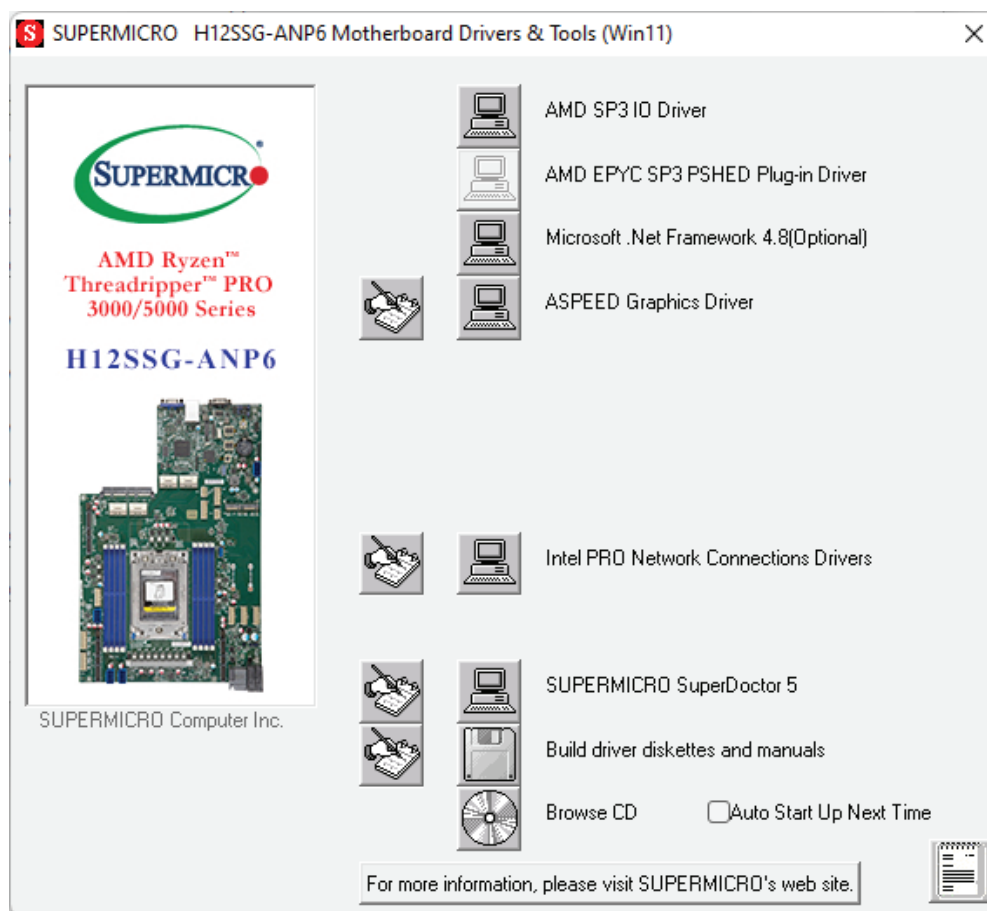

Figure A-3. Driver & Tool Installation Screen

Note: Click the icons showing a hand writing on paper to view the readme files for each item. Click the computer icons to the right of these items to install each item (from top to the bottom) one at a time. **After installing each item, you must re-boot the system before moving on to the next item on the list.** The bottom icon with a CD on it allows you to view the entire contents.

A.3 SuperDoctor® 5

The Supermicro SuperDoctor 5 is a program that functions in a command-line or web-based interface for Windows and Linux operating systems. The program monitors such system health information as CPU temperature, system voltages, system power consumption, fan speed, and provides alerts via email or Simple Network Management Protocol (SNMP).

SuperDoctor 5 comes in local and remote management versions and can be used with Nagios to maximize your system monitoring needs. With SuperDoctor 5 Management Server (SSM Server), you can remotely control power on/off and reset chassis intrusion for multiple systems with SuperDoctor 5 or IPMI. SuperDoctor 5 Management Server monitors HTTP, FTP, and SMTP services to optimize the efficiency of your operation.

[SuperDoctor® Manual and Resources](#)

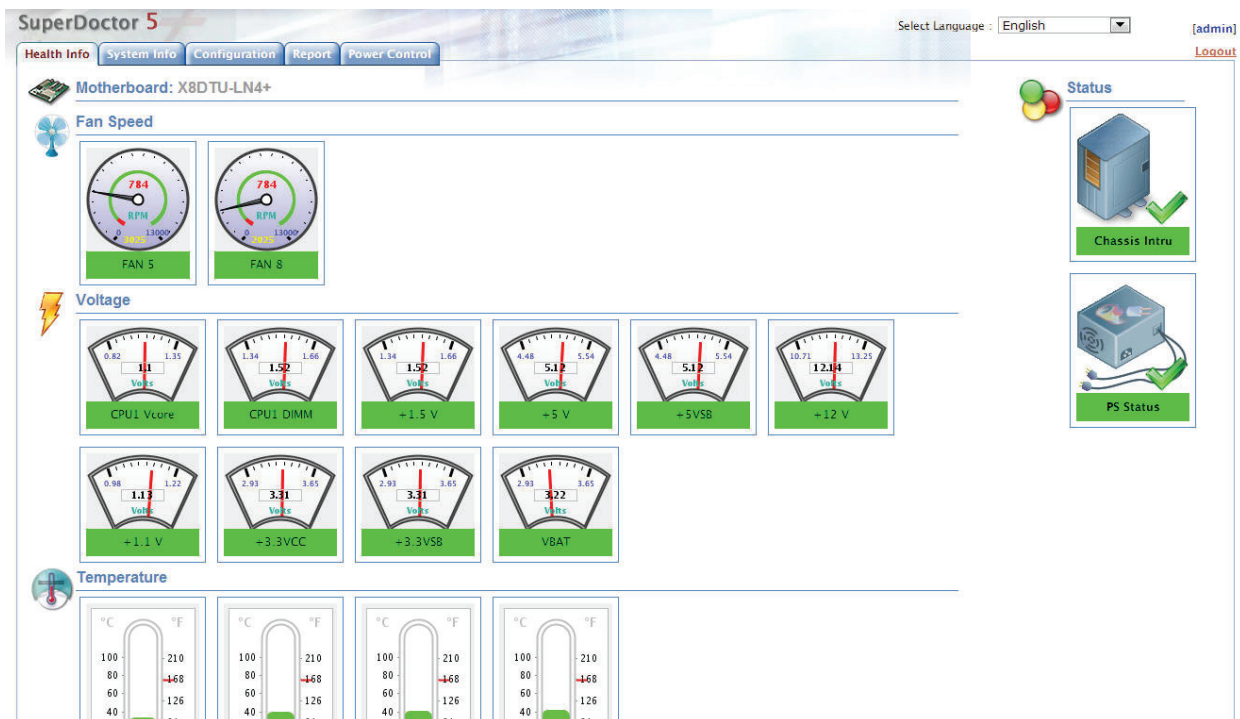

Figure A-4. SuperDoctor 5 Interface Display Screen (Health Information)

A.4 IPMI

The H12SSG-ANP6 supports the Intelligent Platform Management Interface (IPMI). IPMI is used to provide remote access, monitoring and management. There are several BIOS settings that are related to IPMI.

Supermicro ships standard products with a unique password for the BMC ADMIN user. This password can be found on a label on the motherboard.

For general documentation and information on IPMI, please visit our website at: <http://www.supermicro.com/products/nfo/IPMI.cfm>.

Appendix B

Standardized Warning Statements

The following statements are industry standard warnings, provided to warn the user of situations which have the potential for bodily injury. Should you have questions or experience difficulty, contact Supermicro's Technical Support department for assistance. Only certified technicians should attempt to install or configure components.

Read this section in its entirety before installing or configuring components.

These warnings may also be found on our website at http://www.supermicro.com/about/policies/safety_information.cfm.

B.1 Battery Handling



Warning! There is the danger of explosion if the battery is replaced incorrectly. Replace the battery only with the same or equivalent type recommended by the manufacturer. Dispose of used batteries according to the manufacturer's instructions

電池の取り扱い

電池交換が正しく行われなかった場合、破裂の危険性があります。交換する電池はメーカーが推奨する型、または同等のものを使用下さい。使用済電池は製造元の指示に従って処分して下さい。

警告

電池更換不當會有爆炸危險。請只使用同類電池或製造商推薦的功能相當的電池更換原有電池。請按製造商的說明處理廢舊電池。

警告

電池更換不當會有爆炸危險。請使用製造商建議之相同或功能相當的電池更換原有電池。請按照製造商的說明指示處理廢棄舊電池。

Warnung

Bei Einsetzen einer falschen Batterie besteht Explosionsgefahr. Ersetzen Sie die Batterie nur durch den gleichen oder vom Hersteller empfohlenen Batterietyp. Entsorgen Sie die benutzten Batterien nach den Anweisungen des Herstellers.

Attention

Danger d'explosion si la pile n'est pas remplacée correctement. Ne la remplacer que par une pile de type semblable ou équivalent, recommandée par le fabricant. Jeter les piles usagées conformément aux instructions du fabricant.

¡Advertencia!

Existe peligro de explosión si la batería se reemplaza de manera incorrecta. Reemplazar la batería exclusivamente con el mismo tipo o el equivalente recomendado por el fabricante. Desechar las baterías gastadas según las instrucciones del fabricante.

אזהרה!

קיימת סכנת פיצוץ של הסוללה במידה והוחלפה בדרך לא תקינה. יש להחליף את הסוללה בסוג התואם מחברת יצרן מומלצת. סילוק הסוללות המשומשות יש לבצע לפי הוראות היצרן.

هناك خطر من انفجار في حالة اسبدال البطارية بطريقة غير صحيحة فعلياً
اسبدال البطارية
فقط بنفس النوع أو ما يعادلها مما أوصت به الشركة المصنعة
جخلص من البطاريات المسحمة وفقاً لتعليمات الشركة الصانعة

경고!

배터리가 올바르게 교체되지 않으면 폭발의 위험이 있습니다. 기존 배터리와 동일하거나 제조사에서 권장하는 동등한 종류의 배터리로만 교체해야 합니다. 제조사의 안내에 따라 사용된 배터리를 처리하여 주십시오.

Waarschuwing

Er is ontploffingsgevaar indien de batterij verkeerd vervangen wordt. Vervang de batterij slechts met hetzelfde of een equivalent type die door de fabrikant aanbevolen wordt. Gebruikte batterijen dienen overeenkomstig fabrieksvoorschriften afgevoerd te worden.

B.2 Product Disposal



Warning! Ultimate disposal of this product should be handled according to all national laws and regulations.

製品の廃棄

この製品を廃棄処分する場合、国の関係する全ての法律・条例に従い処理する必要があります。

警告

本产品的废弃处理应根据所有国家的法律和规章进行。

警告

本產品的廢棄處理應根據所有國家的法律和規章進行。

Warnung

Die Entsorgung dieses Produkts sollte gemäß allen Bestimmungen und Gesetzen des Landes erfolgen.

¡Advertencia!

Al deshacerse por completo de este producto debe seguir todas las leyes y reglamentos nacionales.

Attention

La mise au rebut ou le recyclage de ce produit sont généralement soumis à des lois et/ou directives de respect de l'environnement. Renseignez-vous auprès de l'organisme compétent.

סילוק המוצר

אזהרה!

סילוק סופי של מוצר זה חייב להיות בהתאם להנחיות וחוקי המדינה.

عند التخلص النهائي من هذا المنتج ينبغي التعامل معه وفقا لجميع القوانين واللوائح الوطنية

경고!

이 제품은 해당 국가의 관련 법규 및 규정에 따라 폐기되어야 합니다.

Waarschuwing

De uiteindelijke verwijdering van dit product dient te geschieden in overeenstemming met alle nationale wetten en reglementen.

Appendix C

UEFI BIOS Recovery

Warning: Do not upgrade the BIOS unless your system has a BIOS-related issue. Flashing the wrong BIOS can cause irreparable damage to the system. In no event shall Supermicro be liable for direct, indirect, special, incidental, or consequential damages arising from a BIOS update. If you need to update the BIOS, do not shut down or reset the system while the BIOS is updating. Doing so may cause a boot failure.

C.1 Overview

The Unified Extensible Firmware Interface (UEFI) provides a software-based interface between the operating system and the platform firmware in the pre-boot environment. The UEFI specification supports an architecture-independent mechanism for add-on card initialization to allow the UEFI OS loader, which is stored in the add-on card, to boot the system. The UEFI offers clean, hands-off control to a computer system at bootup.

C.2 Recovering the UEFI BIOS Image

A UEFI BIOS flash chip consists of a recovery BIOS block and a main BIOS block (a main BIOS image). The boot block contains critical BIOS codes, including memory detection and recovery codes for the user to flash a new BIOS image if the original main BIOS image is corrupted. When the system power is on, the boot block codes execute first. Once it is completed, the main BIOS code will continue with system initialization and bootup.

C.3 Recovering the BIOS Block with a USB Device

If the BIOS file is corrupted and the system is not able to boot up, this feature will allow you to recover the BIOS image using a USB flash or media drive. Please note that a USB hard disk drive is NOT supported. Follow the procedures on the next page to recover the BIOS.

1. Using a different system, copy the standard BIOS binary image file into the root directory of a USB flash or media drive with FAT16 or FAT32 format and rename the file to SUPER.ROM.

Note: If you cannot locate the "SUPER.ROM" file in your driver disk, visit our website at www.supermicro.com to download the correct BIOS image into a USB flash device and rename it "SUPER.ROM".

2. While the system is turned off, insert the USB device that contains the new BIOS binary image (SUPER.ROM).
3. Power on the system.



4. After the system is turned on, the system will enter the BIOS Recovery menu. Select "Proceed with flash update" to start the BIOS recovery process. **DO NOT INTERRUPT THIS PROCESS UNTIL IT FINISHED!**

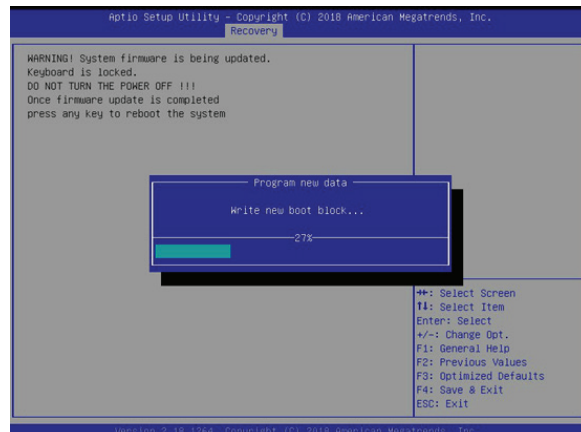
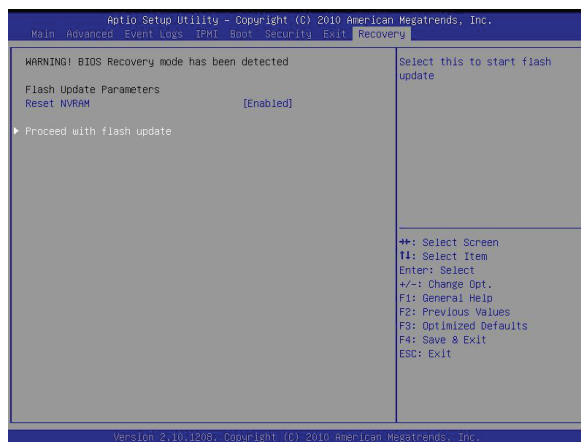

5. After the Boot Sector Recovery Process is complete, press any key to reboot the system.

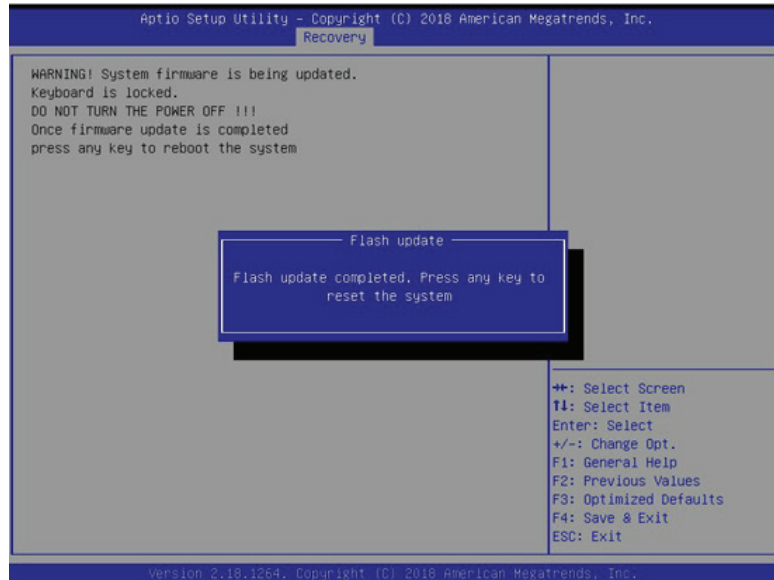
**Notes:**

- * The BIOS recovery (SUPER.ROM) will not work if BIOS has a multi-block crash.
- * If you have purchased an OOB license, you can do a BIOS flash again through BMC WebGUI or SUM. Please refer to these SUPERMICRO software-related videos:
Activate OOB license: https://www.youtube.com/watch?v=V4spX_DOV7I
SUPERMICO BIOS Update: <https://www.youtube.com/watch?v=S8z6iOEHGwY>
- * If the BIOS flash recovery fails, contact our RMA Department to have the BIOS chip reprogrammed. This will require shipping the board to Supermicro for repair.
Submit your RMA request at <https://www.supermicro.com/support/rma>
Please make sure to follow all instructions when returning the motherboard.