



H13DSG-OM

USER'S MANUAL

Revision 1.1

The information in this User's Manual has been carefully reviewed and is believed to be accurate. The vendor assumes no responsibility for any inaccuracies that may be contained in this document, and makes no commitment to update or to keep current the information in this manual, or to notify any person or organization of the updates. **Please Note: For the most up-to-date version of this manual, please see our website at www.supermicro.com.**

Super Micro Computer, Inc. ("Supermicro") reserves the right to make changes to the product described in this manual at any time and without notice. This product, including software and documentation, is the property of Supermicro and/or its licensors, and is supplied only under a license. Any use or reproduction of this product is not allowed, except as expressly permitted by the terms of said license.

IN NO EVENT WILL Super Micro Computer, Inc. BE LIABLE FOR DIRECT, INDIRECT, SPECIAL, INCIDENTAL, SPECULATIVE OR CONSEQUENTIAL DAMAGES ARISING FROM THE USE OR INABILITY TO USE THIS PRODUCT OR DOCUMENTATION, EVEN IF ADVISED OF THE POSSIBILITY OF SUCH DAMAGES. IN PARTICULAR, SUPER MICRO COMPUTER, INC. SHALL NOT HAVE LIABILITY FOR ANY HARDWARE, SOFTWARE, OR DATA STORED OR USED WITH THE PRODUCT, INCLUDING THE COSTS OF REPAIRING, REPLACING, INTEGRATING, INSTALLING OR RECOVERING SUCH HARDWARE, SOFTWARE, OR DATA.

Any disputes arising between manufacturer and customer shall be governed by the laws of Santa Clara County in the State of California, USA. The State of California, County of Santa Clara shall be the exclusive venue for the resolution of any such disputes. Supermicro's total liability for all claims will not exceed the price paid for the hardware product.

FCC Statement: This equipment has been tested and found to comply with the limits for a Class A or Class B digital device pursuant to Part 15 of the FCC Rules. These limits are designed to provide reasonable protection against harmful interference when the equipment is operated in industrial environment for Class A device or in residential environment for Class B device. This equipment generates, uses, and can radiate radio frequency energy and, if not installed and used in accordance with the manufacturer's instruction manual, may cause harmful interference with radio communications. Operation of this equipment in a residential area is likely to cause harmful interference, in which case you will be required to correct the interference at your own expense.

California Best Management Practices Regulations for Perchlorate Materials: This Perchlorate warning applies only to products containing CR (Manganese Dioxide) Lithium coin cells. "Perchlorate Material-special handling may apply. See www.dtsc.ca.gov/hazardouswaste/perchlorate".



WARNING: This product can expose you to chemicals including lead, known to the State of California to cause cancer and birth defects or other reproductive harm. For more information, go to www.P65Warnings.ca.gov.

The products sold by Supermicro are not intended for and will not be used in life support systems, medical equipment, nuclear facilities or systems, aircraft, aircraft devices, aircraft/emergency communication devices or other critical systems whose failure to perform be reasonably expected to result in significant injury or loss of life or catastrophic property damage. Accordingly, Supermicro disclaims any and all liability, and should buyer use or sell such products for use in such ultra-hazardous applications, it does so entirely at its own risk. Furthermore, buyer agrees to fully indemnify, defend and hold Supermicro harmless for and against any and all claims, demands, actions, litigation, and proceedings of any kind arising out of or related to such ultra-hazardous use or sale.

Manual Revision 1.1

Release Date: April 11, 2025

Unless you request and receive written permission from Super Micro Computer, Inc., you may not copy any part of this document. Information in this document is subject to change without notice. Other products and companies referred to herein are trademarks or registered trademarks of their respective companies or mark holders.

Copyright © 2025 by Super Micro Computer, Inc.
All rights reserved.

Printed in the United States of America

Preface

About This Manual

This manual is written for system integrators, IT technicians and knowledgeable end users. It provides information for the installation and use of the H13DSG-OM motherboard.

About This Motherboard

Built upon the functionality and capability of the Dual AMD EPYC™ 9004/9005 (Motherboard revision 2.00 or above is required) series processors, the H13DSG-OM motherboard provides superior graphics capability and system performance while consuming little power. Note that this motherboard is intended to be installed and serviced by professional technicians only. For processor/memory updates, refer to our website at <http://www.supermicro.com/products/>.

Conventions Used in the Manual

Special attention should be given to the following symbols for proper installation and to prevent damage done to the components or injury to yourself:



Warning! Indicates important information given to prevent equipment/property damage or personal injury.



Warning! Indicates high voltage may be encountered when performing a procedure.

Contacting Supermicro

Headquarters

Address: Super Micro Computer, Inc.
980 Rock Ave.
San Jose, CA 95131 U.S.A.

Tel: +1 (408) 503-8000

Fax: +1 (408) 503-8008

Email: marketing@supermicro.com (General Information)
Sales-USA@supermicro.com (Sales Inquiries)
Government_Sales-USA@supermicro.com (Gov. Sales Inquiries)
support@supermicro.com (Technical Support)
RMA@supermicro.com (RMA Support)
Webmaster@supermicro.com (Webmaster)

Website: www.supermicro.com

Europe

Address: Super Micro Computer B.V.
Het Sterrenbeeld 28, 5215 ML
's-Hertogenbosch, The Netherlands

Tel: +31 (0) 73-6400390

Fax: +31 (0) 73-6416525

Email: Sales_Europe@supermicro.com (Sales Inquiries)
Support_Europe@supermicro.com (Technical Support)
RMA_Europe@supermicro.com (RMA Support)

Website: www.supermicro.nl

Asia-Pacific

Address: Super Micro Computer, Inc.
3F, No. 150, Jian 1st Rd.
Zhonghe Dist., New Taipei City 235
Taiwan (R.O.C)

Tel: +886-(2) 8226-3990

Fax: +886-(2) 8226-3992

Email: Sales-Asia@supermicro.com.tw (Sales Inquiries)
Support@supermicro.com.tw (Technical Support)
RMA@supermicro.com.tw (RMA Support)

Website: www.supermicro.com.tw

Table of Contents

Contacting Supermicro.....	4
Chapter 1 Introduction	
1.1 Quick Reference.....	10
Quick Reference Table.....	11
Motherboard Features.....	12
Block Diagram.....	14
1.2 Processor and Chipset Overview.....	15
1.3 Recovery from AC Power Loss.....	15
1.4 System Health Monitoring.....	15
Onboard Voltage Monitors.....	15
Fan Status Monitor with Firmware Control.....	16
Environmental Temperature Control.....	16
System Resource Alert.....	16
1.5 ACPI Features.....	16
1.6 Power Supply.....	17
1.7 Super I/O.....	17
Chapter 2 Installation	
2.1 Static-Sensitive Devices.....	18
Precautions.....	18
Unpacking.....	18
2.2 Motherboard Installation.....	19
Location of Mounting Holes.....	19
Installing the Motherboard.....	21
2.3 Processor and Heatsink Installation.....	22
2.4 Memory Support and Installation.....	30
Memory Support.....	30
DIMM Module Population Guide.....	33
DIMM Installation.....	34
DIMM Removal.....	34
2.5 Front/Rear I/O Module Connectors.....	35
I/O Module Connectors.....	35

2.6 Connectors and Headers	36
Power Supply Connections	36
Headers	37
2.7 Jumper Settings	40
How Jumpers Work.....	40
2.8 LED Indicators.....	42
2.9 M.2 Solid State Drive Installation.....	43
Chapter 3 Troubleshooting	
3.1 Troubleshooting Procedures	44
Before Power On	44
No Power	44
No Video	45
System Boot Failure.....	45
Memory Errors	45
What to Do If the System Is Losing the Setup Configuration.....	45
When the System Becomes Unstable	46
3.2 Technical Support Procedures	47
3.3 Frequently Asked Questions	48
3.4 Returning Merchandise for Service.....	49
3.5 Battery Removal and Installation	49
Battery Removal.....	49
Proper Battery Disposal	50
Battery Installation.....	50
Chapter 4 UEFI BIOS	
4.1 Introduction.....	51
Starting the Setup Utility	51
4.2 Main Setup	52
4.3 Advanced.....	54
4.4 BMC.....	76
4.5 Event Logs	79
4.6 Security.....	81
4.7 Boot Settings.....	85
4.8 Save & Exit.....	87

Appendix A Software

Appendix B Standardized Warning Statements

Chapter 1

Introduction

Congratulations on purchasing your computer motherboard from an industry leader. Supermicro boards are designed to provide you with the highest standards in quality and performance.

Important Links

For your system to work properly, follow the links below to download all necessary drivers/utilities and the user's manual for your server.

- Supermicro product manuals: <http://www.supermicro.com/support/manuals/>
- Product drivers and utilities: <https://www.supermicro.com/wdl>
- Product safety info: http://www.supermicro.com/about/policies/safety_information.cfm
- A secure data deletion tool designed to fully erase all data from storage devices can be found at our website: https://www.supermicro.com/about/policies/disclaimer.cfm?url=/wdl/utility/Lot9_Secure_Data_Deletion_Utility
- If you have any questions, contact our support team at: support@supermicro.com

This manual may be periodically updated without notice. Check the Supermicro website for possible updates to the manual revision level.

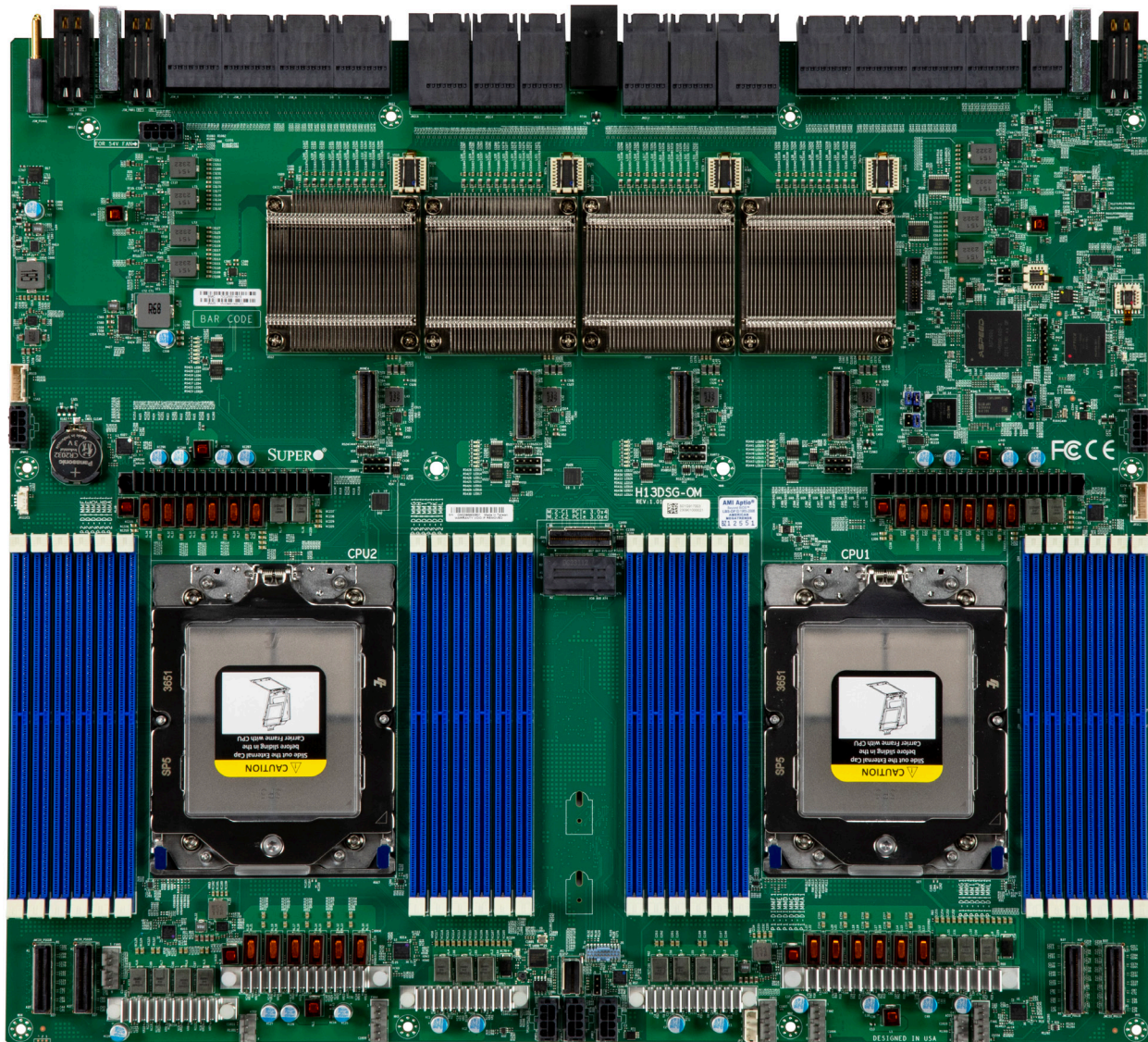
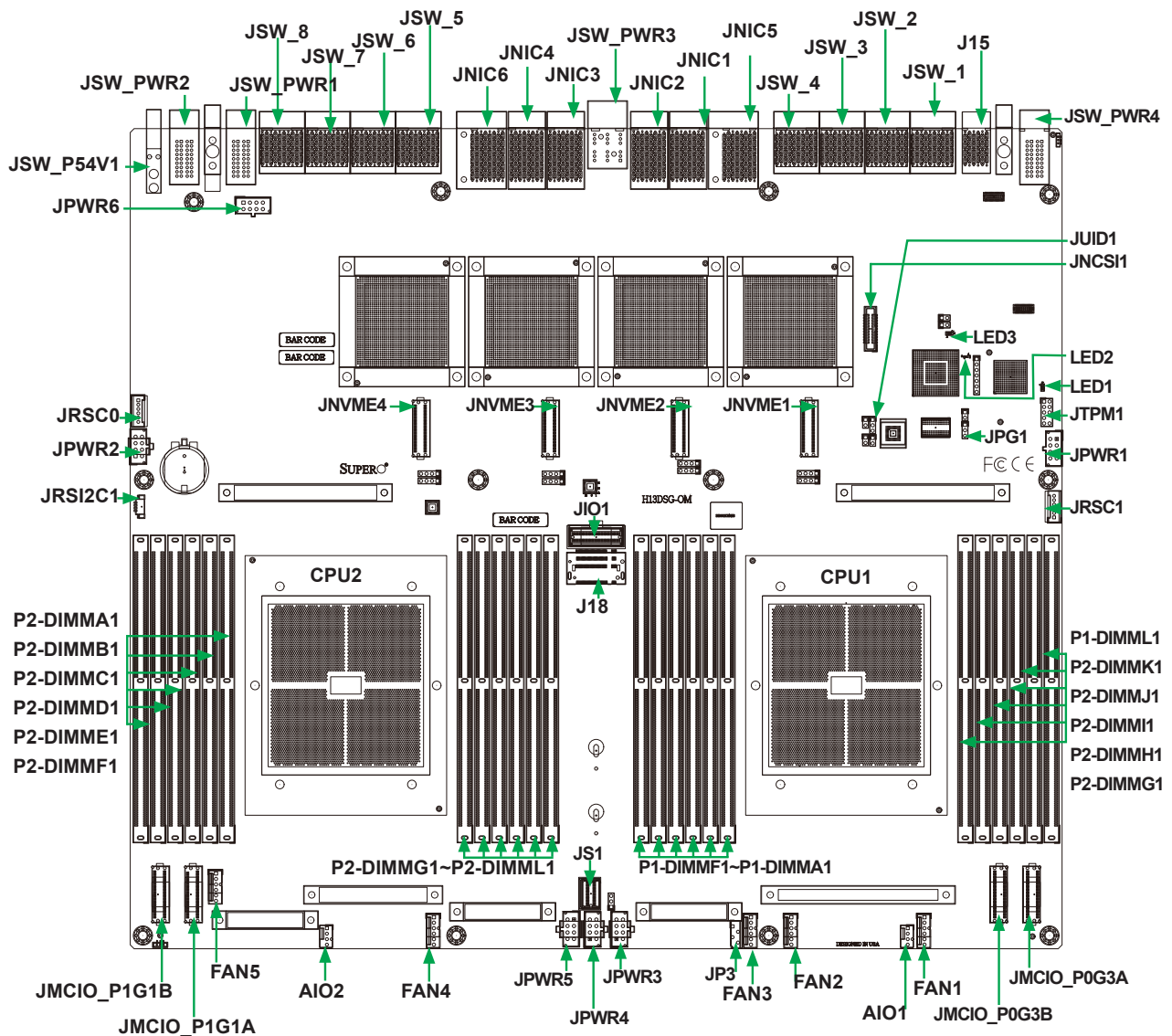

Figure 1-1. H13DSG-OM Motherboard Image

Note: All graphics shown in this manual were based upon the latest PCB revision available at the time of publication of the manual. The motherboard you received may or may not look exactly the same as the graphics shown in this manual.

1.1 Quick Reference



Notes:

- See [Chapter 2](#) for detailed information on jumpers and I/O ports.
- Jumpers/LED indicators not indicated are used for testing only.
- To avoid possible explosion, do not install the onboard battery upside down. Use only the correct type of onboard CMOS battery as specified by the manufacturer.

Quick Reference Table

Jumper	Description	Default Setting
JPG1	VGA Enable/Disable	Pins 1-2 (Enable)
JUID1	Switch function UID/Reset	Pins 1-2 (UID)
LED	Description	Status
LED1	Power LED	Solid Green: Power On
LED2	RoT Status LED	Off: Normal Red on: Fail
LED3	BMC Heartbeat LED	Green: Blinking (BMC Normal) Green: Fast Blinking (BMC Initializing)
Connector	Description	
AIO1~2	4-pin 12 V Header for Liquid-Cooled Solution	
FAN1~5	6-pin System Cooling Fan Header	
J15	Rear I/O Connector	
J18	M.2 - C1 PCIe 3.0 x4 / M.2 - C2 PCIe 3.0 x4	
JIO1	Front Control Panel Connector	
JMCIO_P0G3A JMCIO_P0G3B	PCIe 5.0 x8 (Processor 1)	
JMCIO_P1G1A JMCIO_P1G1B	PCIe 5.0 x8 (Processor 2)	
JNIC1~JNIC6	PCIe Connectors Connected to NIC Card Carrier Board (AOM-GP801-LPIO)	
JNCSI1	NCSI Connector	
JNVME1~4	PCIe 5.0 x8 Ports to Backplane (Vpp available through JNVME1 and JNVME3)	
JP3	Front Fan Board I2C	
JPWR1~2	12 V Power to Side-Switch (AOM-GP401-SW)	
JPWR3~5	12 V Power to Backplane (BPN-NVME5-HS219N-S24 or BPN-MNME5-228N-S4)	
JPWR6	54 V Power to Front Fan Board (AOM-528G-FAN-CAS2)	
JRSC0~1	Side-Band Signal to Side-Switch (AOM-GP401-SW)	
JRSI2C1	I2C Connector for NVMe / SATA Backplane	
JS1	SATA Connector to Backplane	
JSW_P54V1	54 V Power Connector	
JSW_PWR1 JSW_PWR2 JSW_PWR4	12 V Power to Motherboard	
JSW_PWR3	12 V Power to NIC Card Carrier Board (AOM-GP801-LPIO)	
JSW_1~JSW_8	PCIe Connectors Connected to Middle Plane (BPN-GPU-GP801 or BPN-GPU-GP401)	
JTPM1	Trusted Platform Module (TPM)	

Note: Jumpers, connectors, switches, and LED indicators that are not described in the preceding tables are for manufacturing testing purposes only, and are not covered in this manual.

Motherboard Features

CPU

- Dual AMD EPYC™ 9004/9005 (Motherboard revision 2.00 or above is required) series processors in SP5 sockets. CPU TDP supports up to 400 W TDP.

Memory

- Up to 6 TB of ECC DDR5/3DS RDIMM at 4800 MT/s (EPYCTM 9004 series processors)
- Up to 6 TB of ECC DDR5/3DS RDIMM at 6000 MT/s (EPYCTM 9005 series processors with MB Rev 2.00 or above required)*

*For details, please refer to [Section 2.4](#).

DIMM Size

- Up to 256 GB (Motherboard revision 2.00 or above is required.)

Chipset

- System on Chip (SoC)

Expansion Slots

- 128-lane PCIe 5.0 x8 ExaMAX interfaces to GPU baseboard
- 32-lane PCIe 5.0 x8 MCIO interfaces for NIC carrier board

Network

- Aspeed AST2600 BMC chip with one gigabit RJ45 port via AOM-DXF-IO-P

Graphics

- Aspeed AST2600 BMC chip with one VGA port via AOM-DXF-IO-P

I/O Devices

- One SATA 3.0 port (JS1)
- Up to eight NVMe (x8) ports

BIOS

- 256 MB SPI AMI BIOS® SM Flash UEFI BIOS
- ACPI 6.4, SMBIOS 3.5, Plug-and-Play (PnP), RTC (Real Time Clock) wakeup, Riser Card Auto-Detection Support

Power Management

- ACPI power management (S5)
- Wake-On-LAN
- Power-on mode for AC power recovery

System Health Monitoring

- Onboard voltage monitoring for +3.3 V, +5 V, +12 V, +3.3 VStb, +5 VStb
- Onboard temperature monitoring for CPU, System, Memory, and Peripheral
- CPU Thermal Trip support

Note: Table continues on the next page.

Fan Control

- Five 6-pin fan headers
- Fan speed control

System Management

- IPMIView/SMCIPMITOOL/IPMICFG
- SuperDoctor® 5
- SDO/SPM/SSM/SUM-OOB/InBand
- Trusted Platform Module (TPM) support

LED Indicators

- CPU / System Overheating
- Power / Suspend-state Indicator
- Fan Failure

Dimensions

- 16.7" (W) x 15" (L), (424.18 mm x 381 mm)

Note: The CPU maximum thermal design power (TDP) is subject to chassis and heatsink cooling restrictions. For proper thermal management, check the chassis and heatsink specifications for proper CPU TDP sizing.

Block Diagram

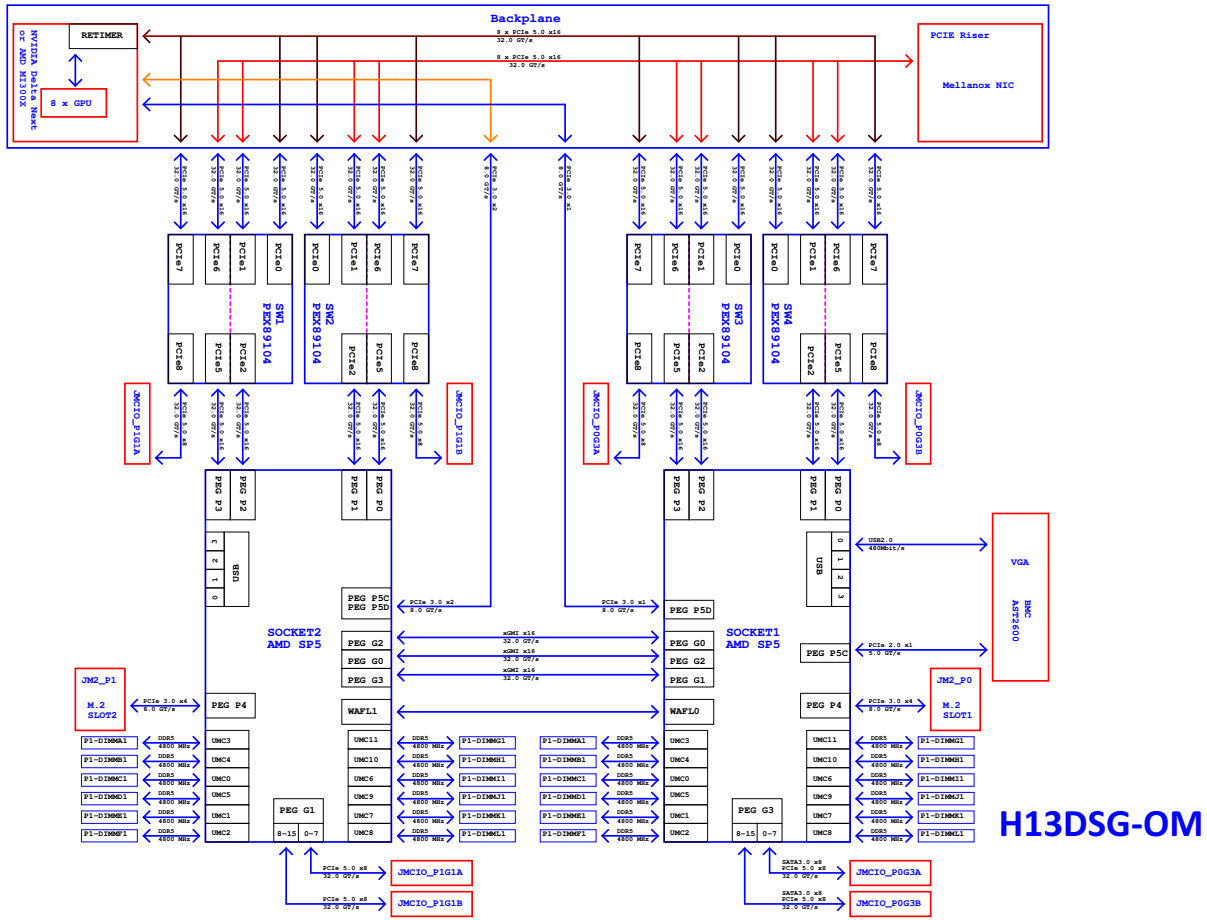

Figure 1-2. System Block Diagram

Note: This is a general block diagram and may not exactly represent the features on your motherboard. See the previous pages for the actual specifications of your motherboard.

1.2 Processor and Chipset Overview

Built upon the functionality and capability of the dual AMD EPYC™ 9004/9005 (Motherboard revision 2.00 or above is required) series processors in SP5 sockets. The H13DSG-OM motherboard offers maximum I/O expendability, energy efficiency, and data reliability in a 5-nm process architecture, and is optimized for embedded storage solutions, networking applications, or cloud-computing platforms.

With support of the new microarchitecture 5-nm process technology, the H13DSG-OM drastically increases system performance for a multitude of server applications.

The dual AMD EPYC™ 9004/9005 (Motherboard revision 2.00 or above is required) series processors support the following features:

- ACPI Power Management Logic Support Rev. 6.4
- Adaptive Thermal Management/Monitoring
- PCIe 5.0 w/transfer rate of up to 32.0 GT/s and SATA 3.0 with transfer rate of up to 6.0 Gb/s
- System Management Bus (SMBus) Specification Version 3.5 or later

1.3 Recovery from AC Power Loss

The Basic I/O System (BIOS) provides a setting that determines how the system will respond when AC power is lost and then restored to the system. You can choose for the system to remain powered off (in which case you must press the power switch to turn it back on), or for it to automatically return to the power-on state. See the Advanced BIOS Setup section for this setting. The default setting is Last State.

1.4 System Health Monitoring

This section describes the health monitoring features of the H13DSG-OM motherboard. The motherboard has an onboard Baseboard Management Controller (BMC) chip that supports system health monitoring. Once a voltage becomes unstable, a warning is given or an error message is sent to the screen. The user can adjust the voltage thresholds to define the sensitivity of the voltage monitor.

Onboard Voltage Monitors

The onboard voltage monitor will continuously scan crucial voltage levels. Once a voltage becomes unstable, it will give a warning or send an error message to the screen. Users can

adjust the voltage thresholds to define the sensitivity of the voltage monitor. Real time readings of these voltage levels are all displayed in BMC.

Fan Status Monitor with Firmware Control

PC health monitoring in the BIOS can check the RPM status of the cooling fans. The onboard CPU and chassis fans are controlled by Thermal Management.

Environmental Temperature Control

The thermal control sensor monitors the CPU temperature in real time and will turn on the thermal control fan whenever the CPU temperature exceeds a user-defined threshold. The overheat circuitry runs independently from the CPU. Once the thermal sensor detects that the CPU temperature is too high, it will automatically turn on the thermal fans to prevent the CPU from overheating. The onboard chassis thermal circuitry can monitor the overall system temperature and alert the user when the chassis temperature is too high.

Note: To avoid possible system overheating, be sure to provide adequate airflow to your system.

System Resource Alert

This feature is available when used with SuperDoctor 5[®]. SuperDoctor 5 is used to notify the user of certain system events. For example, you can configure SuperDoctor 5 to provide you with warnings when the system temperature, CPU temperatures, voltages and fan speeds go beyond a predefined range.

1.5 ACPI Features

ACPI stands for Advanced Configuration and Power Interface. The ACPI specification defines a flexible and abstract hardware interface that provides a standard way to integrate power management features throughout a computer system including its hardware, operating system and application software. This enables the system to automatically turn on and off peripherals such as network cards, hard disk drives and printers.

In addition to enabling operating system-directed power management, ACPI also provides a generic system event mechanism for Plug and Play and an operating system-independent

interface for configuration control. ACPI leverages the Plug and Play BIOS data structures while providing a processor architecture-independent implementation that is compatible with Windows Server 2019 operating systems.

1.6 Power Supply

As with all computer products, a stable power source is necessary for proper and reliable operation. It is even more important for processors that have high CPU clock rates. In areas where noisy power transmission is present, you may choose to install a line filter to shield the computer from noise. It is recommended that you also install a power surge protector to help avoid problems caused by power surges.

1.7 Super I/O

The ASpeed AST2600 Super I/O provides one high-speed, 16550 compatible Universal Asynchronous Receiver/Transmitter (UART), which support serial infrared communications. This UART includes a send/receive FIFO, a programmable baud rate generator, complete modem control capability and a processor interrupt system. This UART provides legacy speed with baud rate of up to 115.2 Kbps as well as an advanced speed with baud rates of 250 K, 500 K, or 1 Mb/s, which support higher speed modems.

The Super I/O provides functions that comply with ACPI (Advanced Configuration and Power Interface), which includes support of legacy and ACPI power management through the System Management Interrupt (SMI) or System Control Interrupt (SCI). It also features auto power management to reduce power consumption. The IRQs, DMAs and I/O space resources of the Super I/O can be flexibly adjusted to meet ISA PnP requirements, which support ACPI and APM (Advanced Power Management).

Chapter 2

Installation

2.1 Static-Sensitive Devices

Electrostatic Discharge (ESD) can damage electronic components. To prevent damage to your motherboard, it is important to handle it very carefully. The following measures are generally sufficient to protect your equipment from ESD.

Precautions

- Use a grounded wrist strap designed to prevent static discharge.
- Touch a grounded metal object before removing the board from the antistatic bag.
- Handle the board by its edges only; do not touch its components, peripheral chips, memory modules or gold contacts.
- When handling chips or modules, avoid touching their pins.
- Put the motherboard and peripherals back into their antistatic bags when not in use.
- For grounding purposes, make sure that your chassis provides excellent conductivity between the power supply, the case, the mounting fasteners and the motherboard.
- Use only the correct type of CMOS onboard battery as specified by the manufacturer. To avoid possible explosion, do not install the CMOS battery upside down.

Unpacking

The motherboard is shipped in antistatic packaging to avoid static damage. When unpacking the motherboard, make sure that the person handling it is static protected.

2.2 Motherboard Installation

All motherboards have standard mounting holes to fit different types of chassis. Make sure that the locations of all the mounting holes for both the motherboard and the chassis match. Although a chassis may have both plastic and metal mounting fasteners, metal ones are highly recommended because they ground the motherboard to the chassis. Make sure that the metal standoffs click in or are screwed in tightly.



Phillips Screwdriver (1)



Phillips Screws (12)



**Standoffs (12)
Only if Needed**

Tools Needed

Location of Mounting Holes

Notes:

1. To avoid damaging the motherboard and its components, do not use a force greater than 8 lb/inch on each mounting screw during motherboard installation.
2. Some components are very close to the mounting holes. Take precautionary measures to avoid damaging these components when installing the motherboard to the chassis.

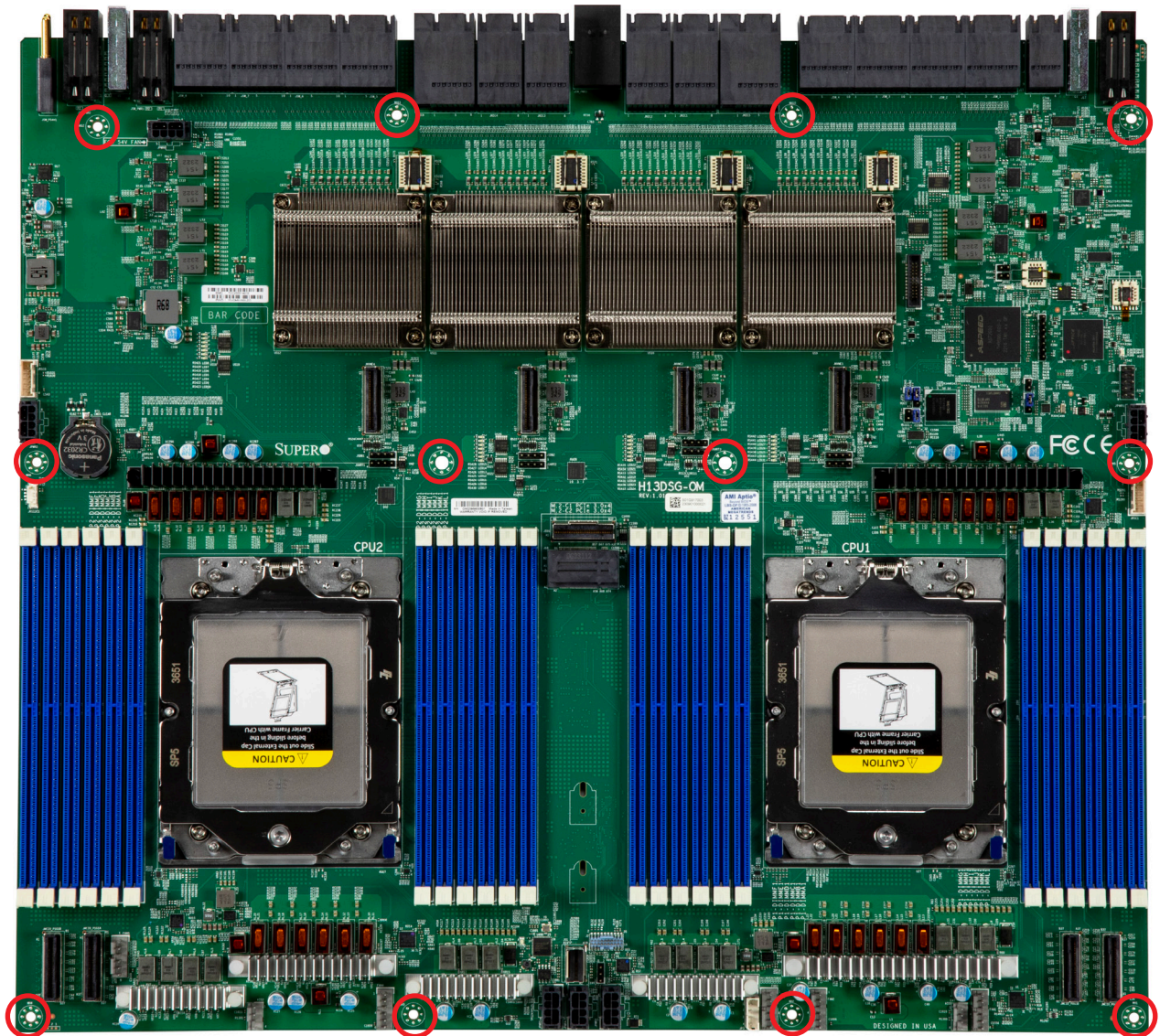
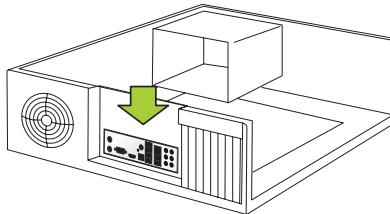

Figure 2-1. Motherboard Mounting Holes

Installing the Motherboard

Note: Always connect the power cord last, and always remove it before adding, removing, or changing any hardware components. Install the I/O shield into the chassis.

1. Install the I/O shield into the back of the chassis.



2. Locate the mounting holes on the motherboard. See the previous page for the location.

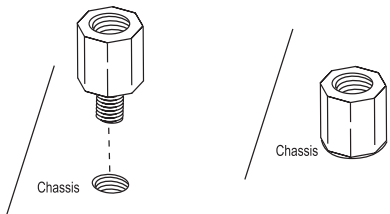

3. Locate the matching mounting holes on the chassis. Align the mounting holes on the motherboard against the mounting holes on the chassis.

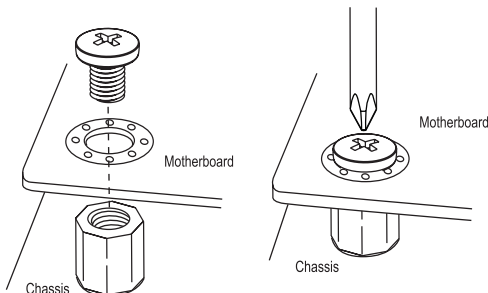

4. Install standoffs in the chassis as needed.
5. Install the motherboard into the chassis carefully to avoid damaging other motherboard components.
6. Using the Phillips screwdriver, insert a Phillips head #6 screw into a mounting hole on the motherboard and its matching mounting hole on the chassis.
7. Repeat Step 5 to insert #6 screws into all mounting holes.
8. Make sure that the motherboard is securely placed in the chassis.

Note: Images displayed are for illustration only. Your chassis or components might look different from those shown in this manual.

2.3 Processor and Heatsink Installation

Warning: When handling the processor package, avoid placing direct pressure on the label area of the fan.

Important:

- For the Processor/Heatsink installation you need to use a T20 screwdriver when opening/closing the CPU socket.
- Always connect the power cord last, and always remove it before adding, removing or changing any hardware components. Make sure that you install the processor into the CPU socket before you install the CPU heatsink.
- If you buy a CPU separately, make sure that you use an AMD-certified multi-directional heatsink only.
- Make sure to install the motherboard into the chassis before you install the CPU heatsink.
- When receiving a motherboard without a processor pre-installed, make sure that the plastic CPU socket cap is in place and none of the socket pins are bent; otherwise, contact your retailer immediately.
- Refer to the Supermicro website for updates on CPU support.

Installing the Processor and Heatsink

1. Unscrew the screw #1 holding down the force frame.

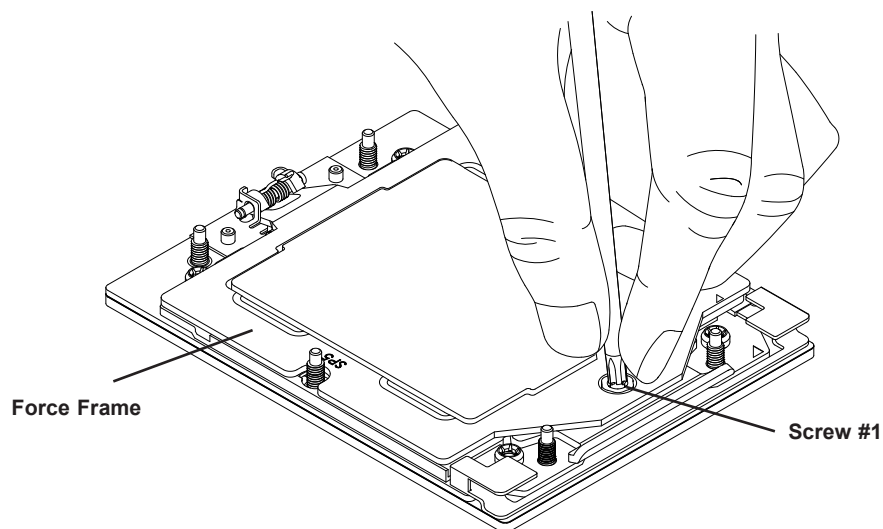

2. The spring-loaded force frame will raise up after the screw securing it (#1) is removed. Gently allow it to lift up to its stopping position.

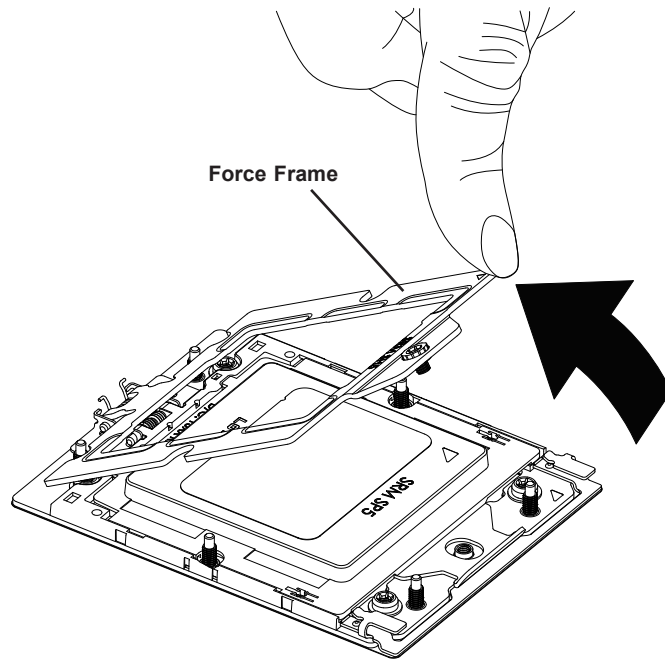

3. Lift the rail frame up by gripping the lift tabs near the front end of the rail frame. While keeping a secure grip of the rail frame, lift it to a position so you can do the next step of removing the external cap.

Note: The rail frame is spring loaded, so keep a secure grip on it as you lift it so it does not snap up.

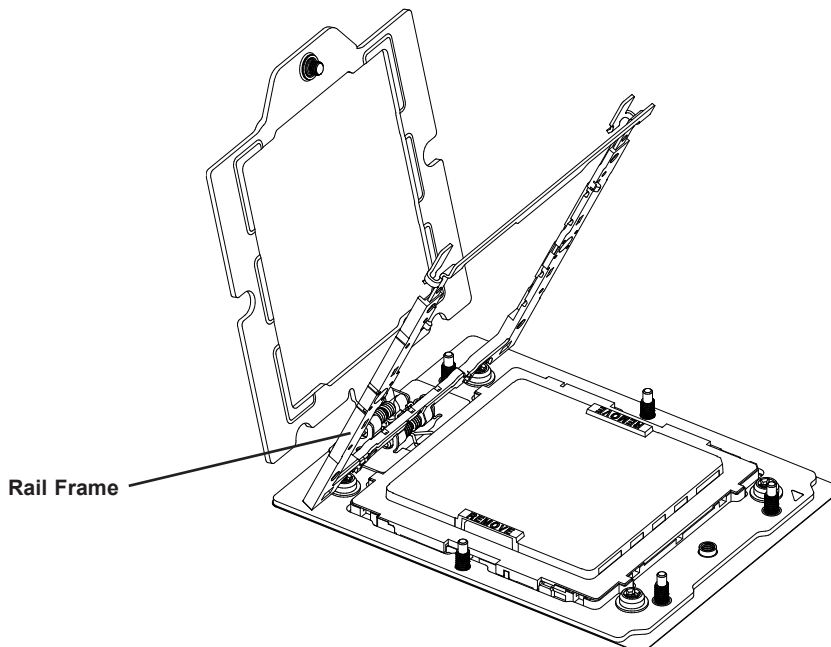

4. Remove the external cap from the rail frame by pulling it upwards through the rail guides on the rail frame.

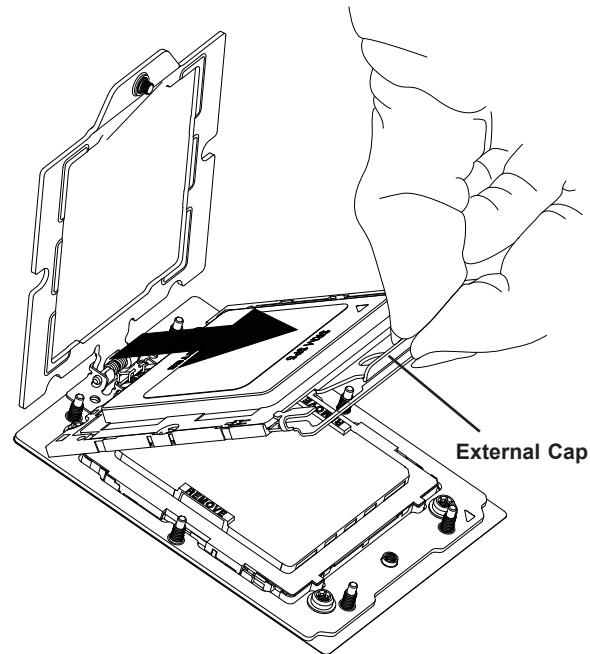

5. The CPU package is shipped from the factory with the carrier frame pre-assembled. Grip the handle of the carrier frame/CPU package assembly from its shipping tray, and while gripping the handle, align the flanges of the carrier frame onto the rails of the rail frame so its pins will be at the bottom when the rail frame is lowered later.
6. Slide the carrier frame/CPU package downwards to the bottom of the rail frame. Ensure the flanges are secure on the rails as you lower it downwards.

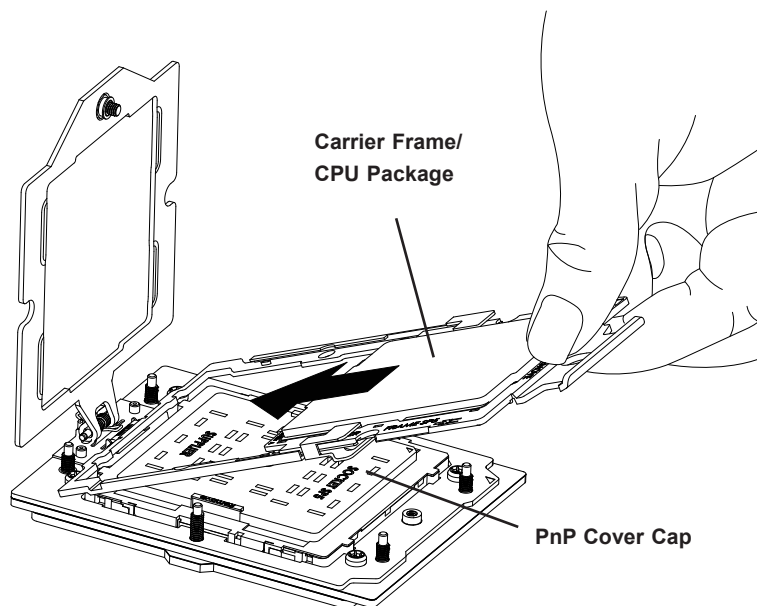

Note: You can only install the CPU inside the socket in one direction with the handle at the top. Make sure that it is properly inserted into the CPU socket before closing the rail frame plate. If it doesn't close properly, do not force it as it may damage your CPU. Instead, open the rail frame plate again, and double-check that the CPU is aligned properly.

7. Lift up the rail frame till it securely rests in upright position. Then remove the PnP cover cap from the CPU socket below. Grip the two lift tabs marked "Remove" at the middle of the cap and pull vertically upwards to remove the PnP cover cap.

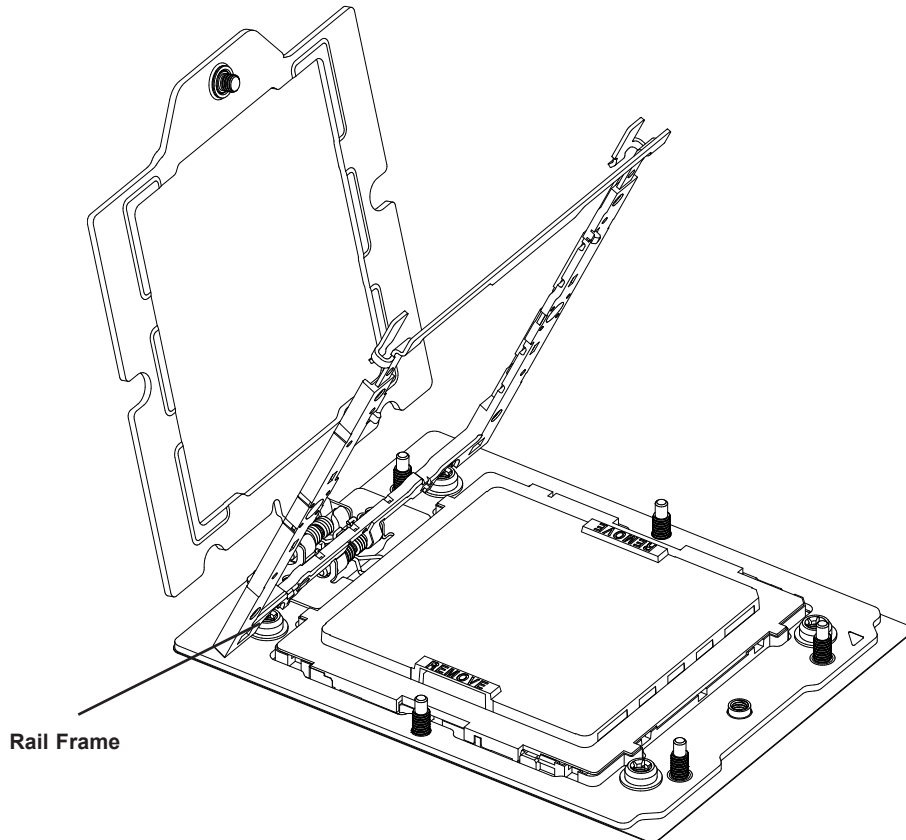

Warning! The exposed socket contacts are extremely vulnerable and can be damaged easily. Do not touch or drop objects onto the contacts and be careful removing the PnP cover cap and when placing the rail frame over the socket.

8. Gently lower the rail frame down onto the socket until the latches on the rail frame engage with the socket housing and it rests in place. **DO NOT** force it into place!

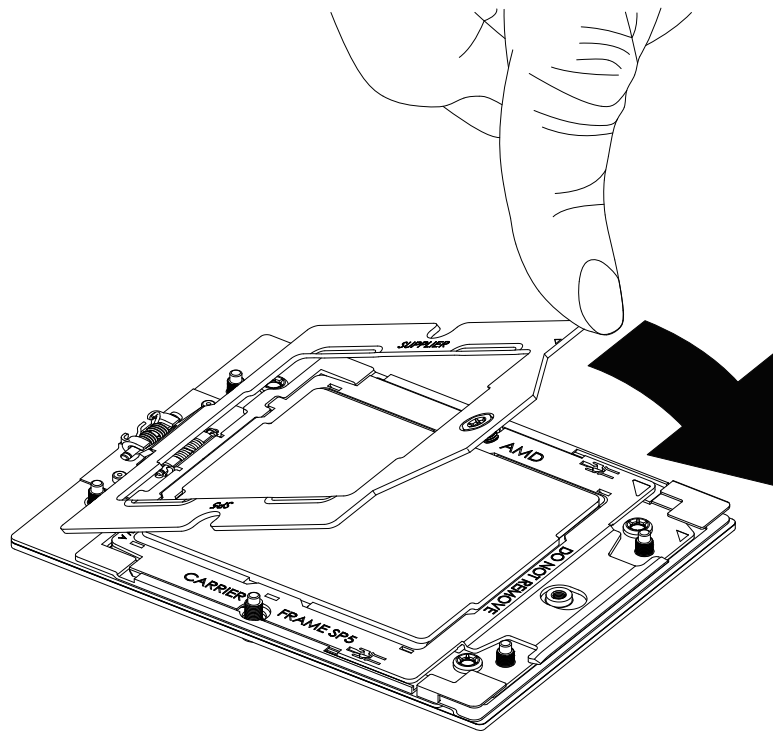

9. The force frame is spring loaded and has to be held in place before it is secured. **Important: Use a torque screwdriver, set it at 12.5~15.0 kgfcm (10.85~13.01 lbf-in) with a Torx T20 screw head bit, to prevent damage to the CPU.**

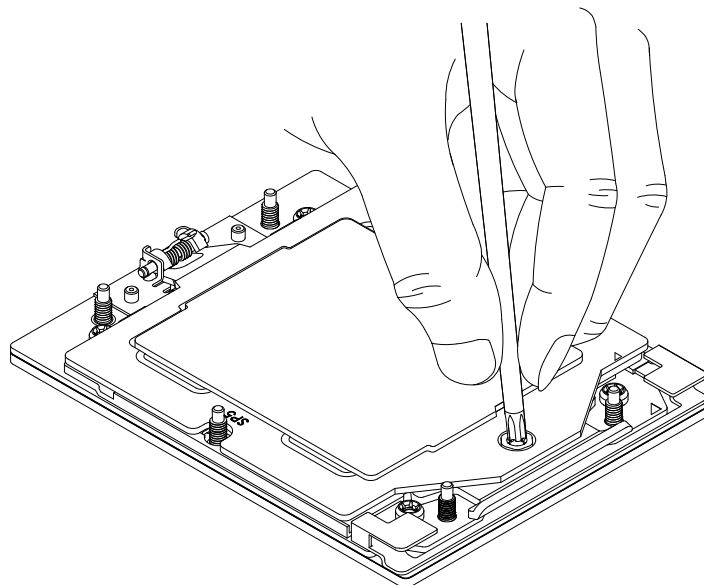

10. Place and re-screw the screw in the middle to the way you removed it. When finished, the force frame will be secure over both the rail frame and CPU package.

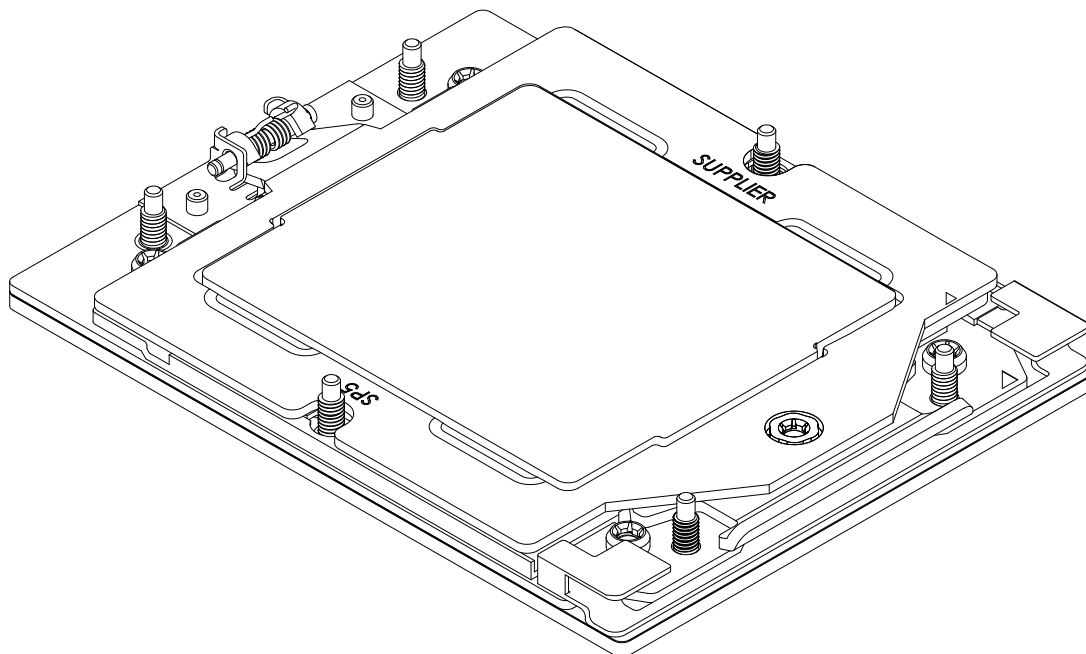

11. After the force frame is secured and the CPU package is in place, now you must install the heatsink to the frame. Lower the heatsink down till it rests securely over the six screw holes on CPU package on the socket frame.

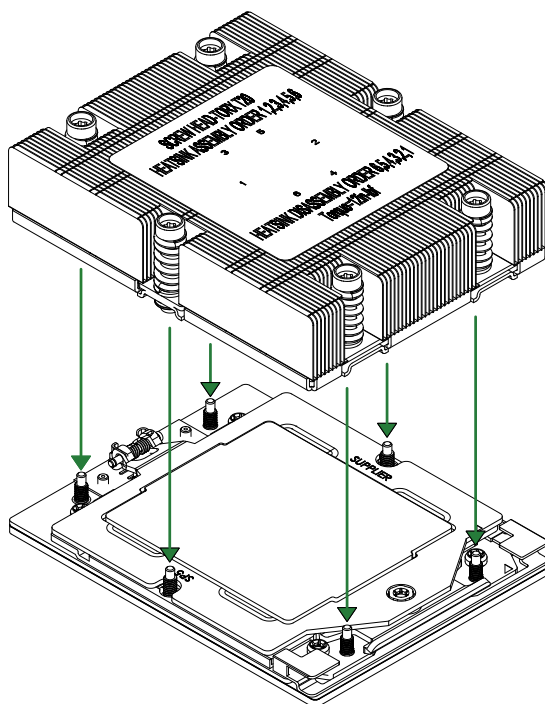

- Using a diagonal pattern, tighten the six screws down on the heatsink in a clockwise fashion till it is secure. The heatsink will now be secured and you have finished installing the processor and heatsink onto the motherboard. Repeat this procedure for any remaining CPU sockets on the motherboard.

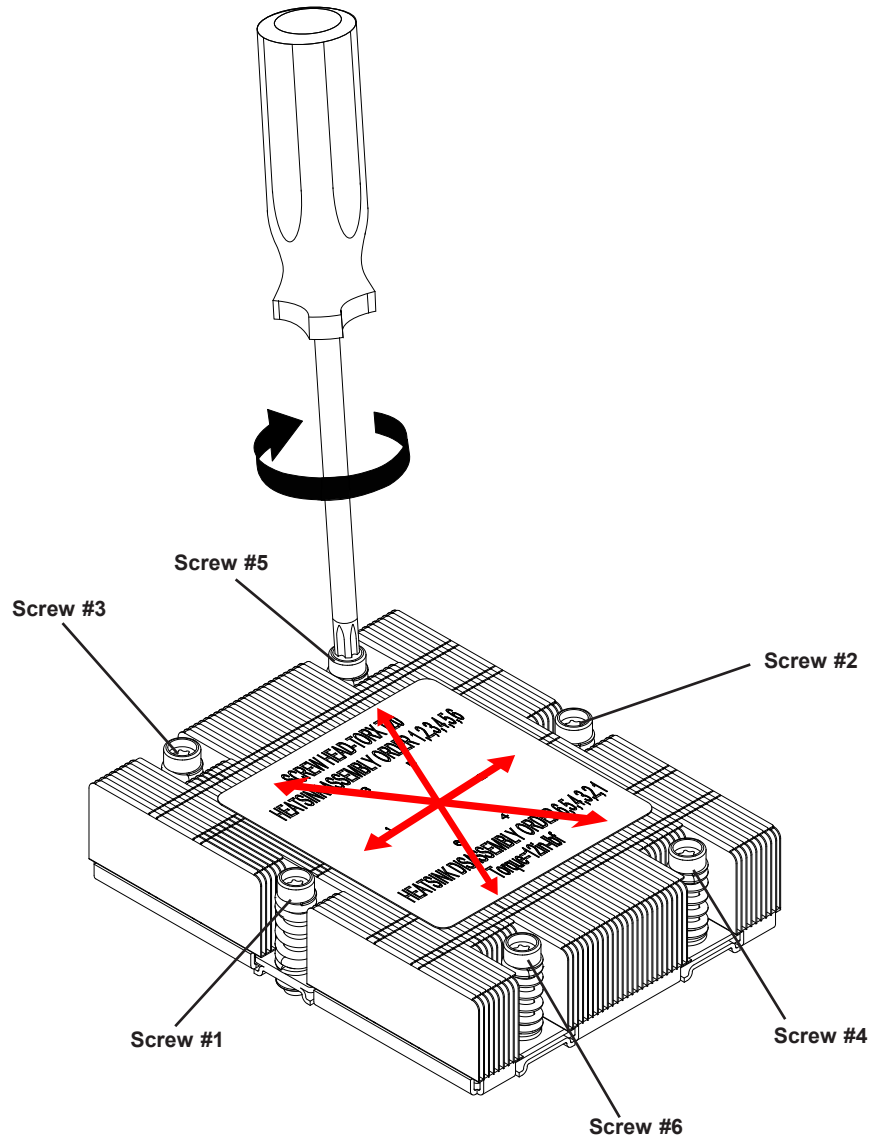

Un-installing the Processor and Heatsink

1. Remove the heatsink attached to the top of the CPU package by reversing the installation procedure.
2. Clean the thermal grease left by the heatsink on the CPU package lid to limit the risk of it contaminating the CPU package landing pads and contacts in the socket housing.
3. Unscrew the plate and lift the force frame to the vertical position.
4. Lift the rail frame using the lift tabs near the front end of the rail frame. Note that the rail frame is spring loaded, so be careful lifting it up into a vertical position.
5. Grip the handle of the carrier frame and pull upwards to extract it from the rail frame. Return the carrier frame/CPU package to its original shipping container.
6. Grip the handle on the external cap and return it to the rail frame sliding it downwards till it rests in the frame.
7. Gripping the rail frame, rotate it downwards till it rests above and locks over the socket housing in its horizontal position.
8. Push and rotate down the force frame till it is over the external cap and rail frame into a horizontal position.
9. While holding down the force frame, secure it back to the socket frame by securing screw #1 in place.

2.4 Memory Support and Installation

Note: Check the Supermicro website for recommended memory modules and updates on possible memory support.

Important: Exercise extreme care when installing or removing DIMM modules to prevent any possible damage.

Memory Support

The H13DSG-OM supports up to 6 TB of ECC DDR5 6000 MT/s speed (Motherboard revision 2.00 or above is required), RDIMM/3DS memory in 24 DIMM slots. Refer to the table below for additional memory information.

DIMM Population Guide for Single CPU														
Type	Channel													
	F1	E1	D1	C1	B1	A1	CPU	G1	H1	I1	J1	K1	L1	Nodes per Socket (NPS) Supported
CPU1 & 1 DIMM						V								NPS1
CPU1 & 2 DIMM						V		V						NPS2, NPS1
CPU1 & 4 DIMM*				V		V		V		V				NPS4, NPS2, NPS1
CPU1 & 6 DIMM				V	V	V		V	V	V				NPS2, NPS1
CPU1 & 8 DIMM		V		V	V	V		V	V	V		V		NPS4, NPS2, NPS1
CPU1 & 10 DIMM		V	V	V	V	V		V	V	V	V	V		NPS2, NPS1
CPU1 & 12 DIMM	V	V	V	V	V	V		V	V	V	V	V	V	NPS4, NPS2, NPS1

DIMM Population Guide for Dual CPUs														
Type		Channel												Nodes per Socket (NPS) Supported
		F1	E1	D1	C1	B1	A1	G1	H1	I1	J1	K1	L1	
2 CPUs and 2 DIMMs	CPU1						V							NPS1
	CPU2						V							
2 CPUs and 4 DIMMs	CPU1						V	V						NPS2, NPS1
	CPU2						V	V						
2 CPUs and 8 DIMMs	CPU1				V		V	V		V				NPS4, NPS2, NPS1
	CPU2				V		V	V		V				
2 CPUs and 12 DIMMs	CPU1				V	V	V	V	V	V				NPS2, NPS1
	CPU2				V	V	V	V	V	V				
2 CPUs and 16 DIMMs	CPU1		V		V	V	V	V	V	V		V		NPS4, NPS2, NPS1
	CPU2		V		V	V	V	V	V	V		V		
2 CPUs and 20 DIMMs	CPU1		V	V	V	V	V	V	V	V	V	V		NPS2, NPS1
	CPU2		V	V	V	V	V	V	V	V	V	V		
2 CPUs and 24 DIMMs	CPU1	V	V	V	V	V	V	V	V	V	V	V	V	NPS4, NPS2, NPS1
	CPU2	V	V	V	V	V	V	V	V	V	V	V	V	

Notes:

- Fully populate the motherboard with validated memory modules to achieve optimal memory performance. The NPS setting depends on the application. Selecting Auto in the BIOS defaults to NPS1.
- See Supermicro FAQ #41217 for instructions on identifying your motherboard's revision: <https://www.supermicro.com/support/faqs/faq.cfm?faq=41217>

Populating RDIMM / 3DS DDR5 Memory Modules with AMD EPYC™ 9004 series Processor			
Type	DIMM Population	Maximum Frequency (MT/s)Frequency	
	DIMM1	5600 MT/s Grade DIMM	4800 MT/s Grade DIMM
RDIMM	1R	4800	4800
	2R	4800	4800
3DS RDIMM	2S2R (4 ranks)	4800	4800
	2S4R (8 ranks)	4800	4800

Populating RDIMM / 3DS DDR5 Memory Modules with AMD EPYC™ 9005 series Processor (Motherboard revision 2.00 or above is required)				
Type	DIMM Population	Maximum Frequency (MT/s)Frequency		
	DIMM1	6400 MT/s Grade DIMM	5600 MT/s Grade DIMM	4800 MT/s Grade DIMM
RDIMM	1R	6000	5600	4800
	2R	6000	5600	4800
3DS RDIMM	2S2R (4 ranks)	6000	5600	4800
	2S4R (8 ranks)	6000	5600	4800

DIMM Module Population Guide

There is no specific order or sequence required when installing memory modules. However do keep the following in mind:

- Always use DDR5 DIMM modules of the same type, size, and speed.
- All twelve channels should be populated with the same capacity to achieve the best performance in most cases.
- In most configurations, populating fewer than twelve channels is supported but not recommended.

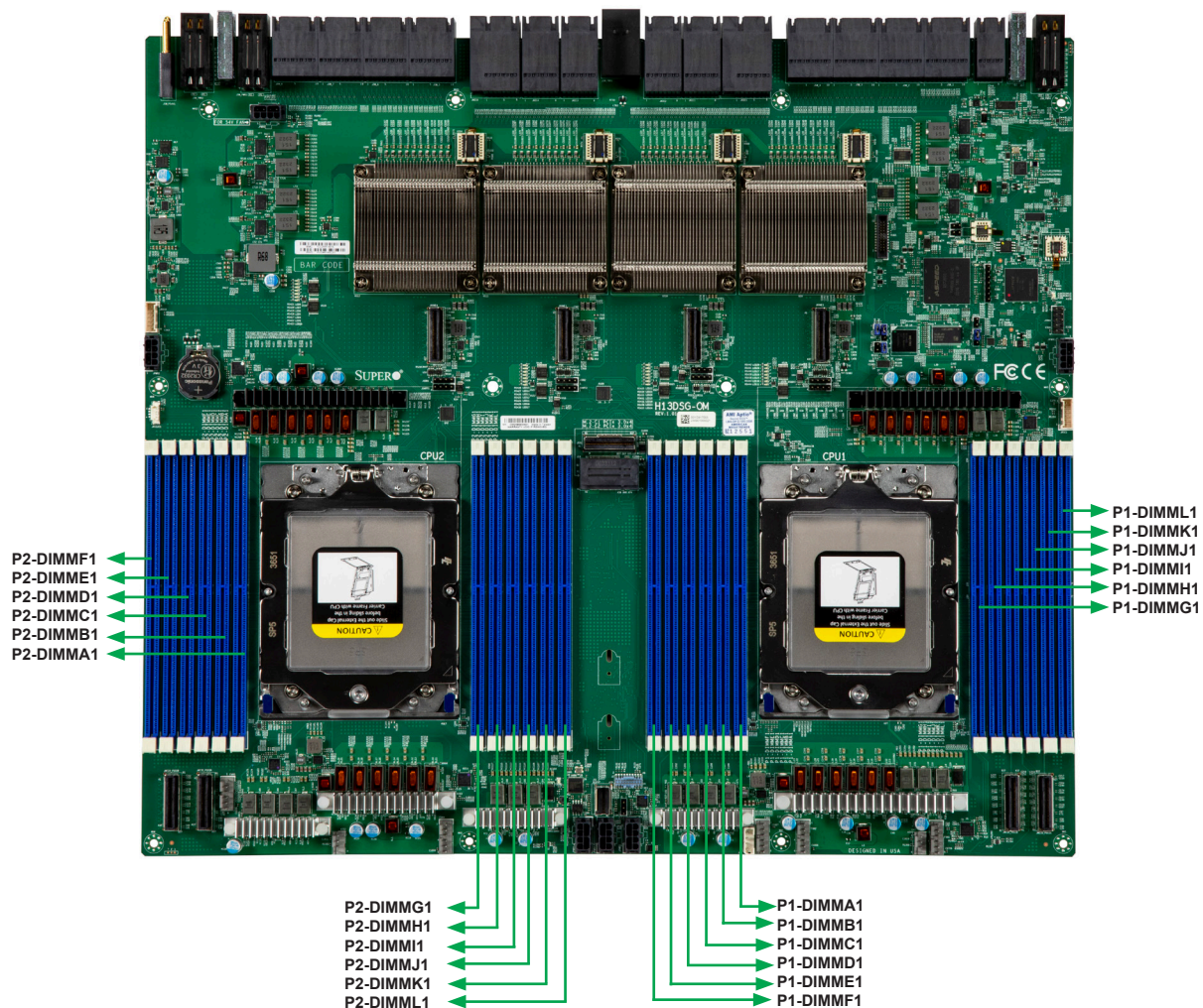
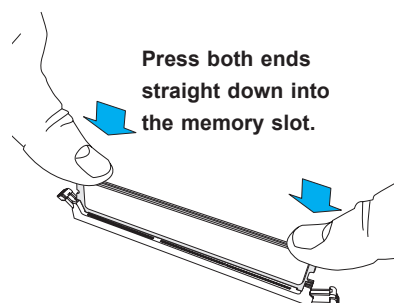
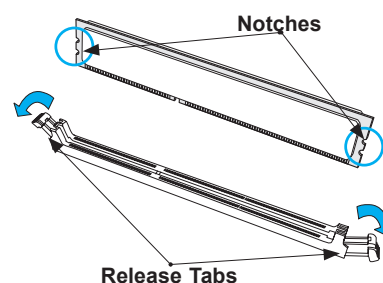
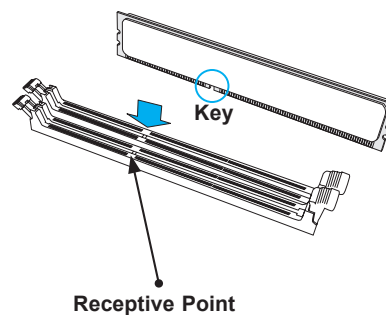

Figure 2-2. DIMM Numbering

DIMM Installation

1. Insert the desired number of DIMMs into the memory slots, see [DIMM Module Population Guide](#) for details.
2. Push the release tabs outwards on both ends of the DIMM slot to unlock it.
3. Align the key of the DIMM module with the receptive point on the memory slot.
4. Align the notches on both ends of the module against the receptive points on the ends of the slot.
5. Press both ends of the module straight down into the slot until the module snaps into place.
6. Press the release tabs to the lock positions to secure the DIMM module into the slot.



DIMM Removal

Press both release tabs on the ends of the DIMM module to unlock it. Once the DIMM module is loosened, remove it from the memory slot.

2.5 Front/Rear I/O Module Connectors

I/O Module Connectors

Two connectors on the motherboard provide I/O module connections.

- **Rear I/O:** An ExaMAX connector located at J15 supports the rear I/O module connection via the midplane. It supports two USB 3.0 ports, one VGA port, and one BMC dedicated LAN port.
- **Front access:** The connector located at JIO1 provides connection to an I/O module. It supports one UID switch, and one UID LED indicator.

Note: J15 and JIO1 connectors are mutually exclusive; only one connector can be utilized at a time.

2.6 Connectors and Headers

Power Supply Connections

Power Supply Connectors

The H13DSG-OM has four PowerMAX power input connectors: JSW_PWR1, JSW_PWR2, and JSW_PWR4 for 12 VDC power input via the midplane, and JSW_P54V1 for 54 VDC power input via the midplane.

Power Connector for NIC Card Carrier Board

JSW_PWR3 is a PowerMAX connector providing 12 VDC power. It is designed to deliver power to the NIC card carrier board.

Fan Board 54 V 8-pin Connector

JPWR6 is an 8-pin, 54 VDC Power connector for the system's fan board. Refer to the table below for pin definitions.

Fan Board Power Pin Definitions			
Pin#	Definition	Pin#	Definition
1	Ground	5	+54 V
2	Ground	6	+54 V
3	Ground	7	+54 V
4	Ground	8	+54 V

Backplane and Side-Switch 12 V 8-pin Power Connectors

JPWR1-5 are 8-pin 12 VDC power inputs for the system's backplane and side-switch. Refer to the table below for pin definitions.

8-Pin Power Pin Definitions			
Pin#	Definition	Pin#	Definition
1	Ground	5	+12 V
2	Ground	6	+12 V
3	Ground	7	+12 V
4	Ground	8	+12 V

Midplane and NIC Card Carrier Board Connectors

There are eight ExaMax connectors (JSW_1 to JSW_8) on the motherboard to connect to the midplane for GPU system.

In addition, there are six PCIe 5.0 ExaMax connectors (JNIC1 to 6) to connect to the NIC card carrier board, which supports eight PCIe 5.0 x16 connections.

SATA Port

The H13DSG-OM has one SATA 3.0 port (JS1) that is supported by ASMEDIA ASM1061.

Headers

Fan Headers (FAN1 to FAN5)

There are five fan headers (FAN1 to FAN5) on the motherboard. These are 6-pin fan headers, with pins 1-3 being backward compatible with traditional 3-pin fans. The onboard fan speeds are controlled by Fan Mode in the BMC. When using Fan Mode setting, use all 6-pin fans.

Fan Header Pin Definitions	
Pin#	Definition
1	Ground (Black)
2	+12 V (Red)
3	Tachometer (Yellow)
4	PWM control (Blue)
5	12 V
6	Ground

TPM Header/Port 80 Connector

A Trusted Platform Module (TPM)/Port 80 header is located at JTPM1 to provide TPM support and Port 80 connection. Use this header to enhance system performance and data security. Refer to the table below for pin definitions. For more information on the TPM, go to the following link: <http://www.supermicro.com/manuals/other/TPM.pdf>.

Trusted Platform Module Header Pin Definitions			
Pin#	Definition	Pin#	Definition
1	+3.3 V	2	SPI_CS#
3	RESET#	4	SPI_MISO
5	SPI_CLK	6	GND
7	SPI_MOSI	8	NC
9	+3.3 V Stdby	10	SPI_IRQ#

NC-SI Connector

The NC-SI (Network Controller Sideband Interface) connector is located at (JNCSI1). This connector is used to connect a Network Interface Card (NIC) to the motherboard to allow the onboard BMC (Baseboard Controller) to communicate with a network.

Note: For detailed instructions on how to configure Network Interface Card (NIC) settings, please refer to the Network Interface Card Configuration User's Guide posted on the web page under the link: <https://www.supermicro.com/support/manuals/>.

Side Switch Board I2C Headers

Two I2C headers for side switch boards are located at JRSC0 and JRSC1 on the motherboard. Connect the appropriate cables here to use the I2C connections for the side switch boards on your system. See the table below for pin definitions.

Side Switch Board I2C Header Pin Definitions	
Pin#	Definition
1	P3V3_AUX
2	SCL
3	SDA
4	GND
5	GND
6	P3V3_AUX

Fan Board I2C Header

An I2C fan header for the fan board is located at JP3. Fan speed control for this fan is supported by Thermal Management via the BMC 2.0 interface. See the table below for pin definitions.

Fan Board I2C Header Pin Definitions	
Pin#	Definition
1	SDA
2	GND
3	SCL
4	P3V3_AUX

NVMe / SATA I2C Header

The NVMe / SATA SMBus (I2C) header (JRSI2C1) provides hot-plug support via a dedicated SMBus interface. This feature is only available for a Supermicro complete system with an Supermicro-proprietary NVMe / SATA add-on card and a proper cable installed. See the table below for pin definitions.

NVMe / SATA I2C Header Pin Definitions	
Pin#	Definition
1	SDA
2	GND
3	SCL
4	P3V3_AUX

Liquid Cooling Leak Detection Connector

Two liquid cooling leak detection connectors are located at AIO1 and AIO2 on the motherboard. AIO1 is used for leak detection on the CPU side, while AIO2 is used for leak detection on the GPU side. Attach the appropriate cable from the chassis to inform you when the leak is detected. Refer to the table below for pin definitions.

Leak Detection Connector Pin Definitions	
Pin#	Definition
1	Ground
2	12 V
3	Detection Pin
4	Not used

PCIe 3.0 NVMe M.2 Slots

Two PCIe 3.0 x4 NVMe M.2 slots are located at J18 on the motherboard. These M.2 slots support M.2 NVMe SSDs in the 2280 and 22110 form factors. M.2 allows for a variety of card sizes, increased functionality, and spatial efficiency.

MCIO NVMe Connectors

The motherboard has four MCIO x8 connectors (JNVME1 to 4) supported by the PLX switches. Each of these connectors supports two PCIe 5.0 x4 NVMe connections.

Note: When connecting an NVMe device to the motherboard, please be sure to connect the first NVMe port (JNVME1) first for your system to work properly.

In addition, there are four MCIO x8 connectors supported by the CPUs. JMCIO_P0G3A and JMCIO_P0G3B are supported by CPU1 while JMCIO_P1G1A and JMCIO_P1G1B are supported by CPU2. These MCIO connectors are used to connect to side switch boards for expansions.

2.7 Jumper Settings

How Jumpers Work

To modify the operation of the motherboard, jumpers can be used to choose between optional settings. Jumpers create shorts between two pins to change the function of the connector. Pin #1 is identified with a square solder pad on the printed circuit board. See the diagram below for an example of jumping pins 1 and 2. Refer to the motherboard layout page for jumper locations.

Note: On two-pin jumpers, "Closed" means the jumper is on and "Open" means the jumper is off the pins.

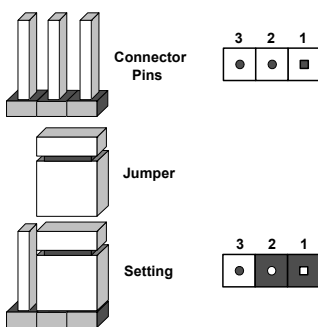

To Clear CMOS

1. First, power down the system and unplug the power cord(s).
2. Pull out the motherboard tray to access the motherboard.
3. Remove the CMOS battery from the motherboard.
4. Wait for around 30 seconds, and then re-install the CMOS battery on the motherboard.
5. Re-install the motherboard tray, reconnect the power cord(s), and power on the system.

Note: Clearing CMOS will also clear all passwords.

Do not use the PW_ON connector to clear CMOS.

JPG1

JPG1 enables or disables the VGA connector. The default setting is enabled.

JPG1	
Jumper Position	Definition
Pins 1-2	Enabled
Pins 2-3	Disabled

JUID1

JUID1 is used for a chassis that supports a front UID button. Setting JUID1 to Pins 2-3 configures the front UID button as a reset button.

JUID1	
Jumper Position	Definition
Pins 1-2	Switch function UID
Pins 2-3	Reset

2.8 LED Indicators

Onboard Power LED (LED1)

LED1 is an onboard power LED. When this LED is lit, it means system is in power-on state, and the onboard power status is ok. Turn off the system and unplug the power cord before removing or installing components.

Onboard Power LED Indicator	
LED Color	Definition
Off	System Off (power cable not connected)
Green	System On, Power OK

RoT Status LED (LED2)

A RoT (Root-of-Trust) status LED is located at LED2 on the motherboard. When this LED is lit, it means the RoT check has failed. See the table below for more information.

RoT Status LED Indicator	
Color	Definition
Off	Normal
Red	Fail

BMC Heartbeat LED (LED3)

A BMC Heartbeat LED is located at LED3 on the motherboard. When this LED is lit green, it indicates the state of BMC. See the table below for more information.

BMC Heartbeat LED State	
State	Definition
Solid On	BMC is not ready.
Blinking	BMC Normal
Fast Blinking	BMC: Initializing

2.9 M.2 Solid State Drive Installation

Installing Dual M.2 SSDs

1. Disconnect power from the motherboard or system.
2. Refer to the motherboard layout and locate the M.2 dual slot (J18).
3. Insert lower M.2 sideways into the connector so that it lays flat, then follow the instructions below from ① to ③.
4. Insert upper M.2 sideways into the connector so that it lays flat, then follow the instructions below from ④ to ⑥.

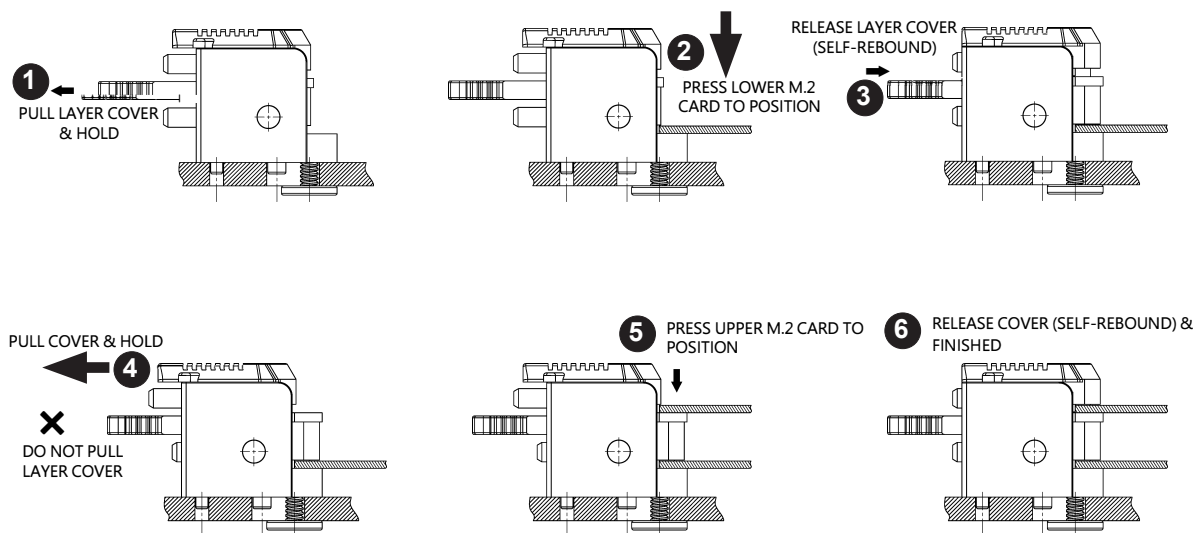

Figure 2-3. Installing Dual M.2 SSDs

Releasing Dual M.2 SSDs

1. Follow the instructions below from ① to ⑤ to remove M.2 SSDs.

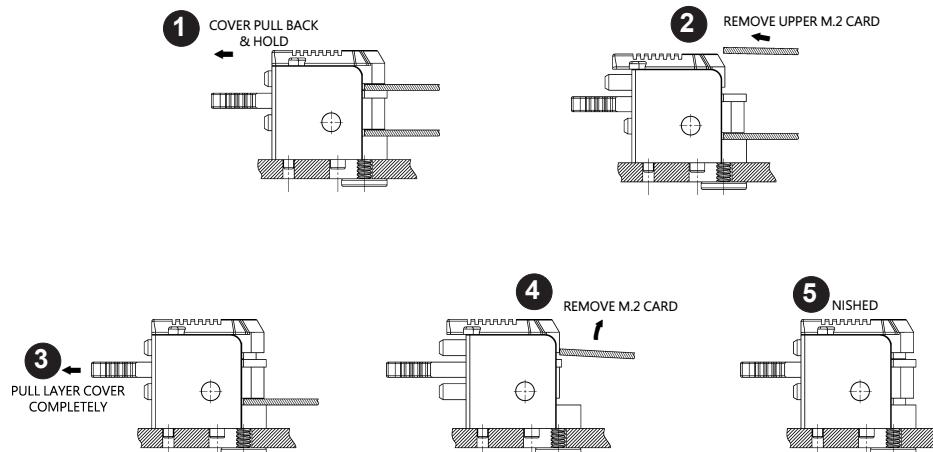

Figure 2-4. Releasing Dual M.2 SSDs

Chapter 3

Troubleshooting

3.1 Troubleshooting Procedures

Use the following procedures to troubleshoot your system. If you have followed all of the procedures below and still need assistance, refer to the 'Technical Support Procedures' and/or 'Returning Merchandise for Service' section(s) in this chapter. Always disconnect the AC power cord before adding, changing or installing any non hot-swappable hardware components.

Before Power On

1. Check that the BMC Heartbeat LED (LED3) is blinking before the motherboard is turned on.
2. Check that the Power LED (LED1) on the motherboard is on.
3. Make sure that the power connector is connected to your power supply.
4. Make sure that no short circuits exist between the motherboard and chassis.
5. Disconnect all cables from the motherboard, including those for the keyboard and mouse.
6. Remove all add-on cards.
7. Install a CPU, a heatsink*, and at least one DIMM on the motherboard. Check all jumper settings properly. *Make sure that the heatsink is fully seated.
8. Use only the correct type of onboard CMOS battery (CR2032) as recommended by the manufacturer. To avoid possible explosion, do not install the CMOS battery upside down.

No Power

1. Make sure that no short circuits exist between the motherboard and the chassis.
2. Verify that all jumpers are set to their default positions.
3. Check that the 115 V/230 V switch on the power supply is properly set.
4. Turn the power switch on and off to test the system

5. The CMOS battery on your motherboard may be old. Check to verify that it still supplies approximately 3 V DC. If it does not, replace it with a new one.

No Video

1. Check that the VGA cable is connected properly, and the monitor is on.
2. Check if you follow the guidelines to install the memory module (see [DIMM Module Population Guide](#) in chapter 2).
3. Reseat the memory DIMM modules.

Note: If you are a system integrator, VAR or OEM, a POST diagnostics card is recommended.

System Boot Failure

If the system does not display POST (Power-On-Self-Test) or does not respond after the power is turned on, check the following:

1. Clear the CMOS settings by unplugging the power cord and removing the battery for 30 seconds. See [To Clear CMOS](#) in chapter 2.
2. Remove all components from the motherboard, especially the DIMM modules.
3. Turn on the system with only one DIMM module installed. If the system boots, check for bad DIMM modules or slots by following the Memory Errors Troubleshooting procedure in this chapter.

Memory Errors

1. Make sure that the DIMM modules are properly and fully installed.
2. Confirm that the correct DIMM modules are being used. Also, it is recommended that you use the DIMM modules of the same memory type and speed in the system. See [Section 2.4](#) for memory details.
3. Check for bad DIMM modules or slots by swapping modules between slots and noting the results.
4. Check the power supply voltage 115 V/230 V switch.

What to Do If the System Is Losing the Setup Configuration

1. Make sure that you are using a high quality power supply. A poor quality power supply may cause the system to lose the CMOS setup information. Refer to [1.6 Power Supply](#) for details on power supplies.

2. The battery on your motherboard may be old. Check to verify that it still supplies approximately 3 V DC. If it does not, replace it with a new one.
3. If the above steps do not fix the setup configuration problem, contact your vendor for repairs.

When the System Becomes Unstable

A. If the system becomes unstable during or after OS installation, check the following:

1. CPU/BIOS support: Make sure that your CPU is supported and that you have the latest BIOS installed in your system.
2. Memory support: Make sure that the memory modules are supported by testing the modules using memtest86 or a similar utility.

Note: Refer to the product page on our website at <http://www.supermicro.com> for memory and CPU support and updates.

3. HDD support: Make sure that all hard disk drives (HDDs) work properly. Replace the bad HDDs with good ones.
4. System cooling: Check that all heatsink fans and CPU/system fans, etc., work properly. Check the hardware monitoring settings in the IPMI to make sure that the CPU and system temperatures are within the normal range. Also check the front panel Overheat LED and make sure that it is not on.
5. Adequate power supply: Make sure that the power supply provides adequate power to the system. Make sure that all power connectors are connected. Refer to our website for more information on the minimum power requirements.
6. Proper software support: Make sure that the correct drivers are used.

B. If the system becomes unstable before or during OS installation, check the following:

1. Source of installation: Make sure that the devices used for installation are working properly, including boot devices such as USB flash or media drives.
2. Cable connection: Check to make sure that all cables are connected and working properly.
3. Using the minimum configuration for troubleshooting: Remove all unnecessary components (starting with add-on cards first), and use the minimum configuration (but with a CPU and a memory module installed) to identify the trouble areas. Refer to the steps listed in Section A above for proper troubleshooting procedures.

4. Identifying bad components by isolating them: If necessary, remove a component in question from the chassis, and test it in isolation to make sure that it works properly. Replace a bad component with a good one.
5. Check and change one component at a time instead of changing several items at the same time. This will help isolate and identify the problem.
6. To find out if a component is good, swap this component with a new one to see if the system will work properly. If so, then the old component is bad. You can also install the component in question in another system. If the new system works, the component is good and the old system has problems.

3.2 Technical Support Procedures

Before contacting Technical Support, take the following steps. Also, note that as a motherboard manufacturer, we do not sell directly to end-users, so it is best to first check with your distributor or reseller for troubleshooting services. They should know of any possible problem(s) with the specific system configuration that was sold to you.

1. Review the 'Troubleshooting Procedures' and 'Frequently Asked Questions' (FAQs) sections in this chapter or see the FAQs on our website before contacting Technical Support.
2. BIOS upgrades can be downloaded from our website.

Note: Not all BIOS can be flashed depending on the modifications to the boot block code.

3. If you still cannot resolve the problem, include the following information when contacting Supermicro for technical support:
 - Motherboard model and PCB revision number
 - BIOS release date/version (this can be seen on the initial display when your system first boots up)
 - Serial number and configuration

An example of a Technical Support form is posted on our website.

Distributors: For immediate assistance, have your account number ready when contacting our technical support department by e-mail.

3.3 Frequently Asked Questions

Question: What type of memory does my motherboard support?

Answer: The H13DSG-OM motherboard supports up to 6 TB of ECC DDR5 4800 MT/s speed with AMD EPYC™ 9004 processors installed, and up to 6 TB of ECC DDR5 6000 MT/s speed with AMD EPYC™ 9005 processors installed on motherboard revision 2.00. See [Section 2.4](#) for details on installing memory.

Question: How do I update my BIOS?

Answer: It is recommended that you **do not** upgrade your BIOS if you are not experiencing any problems with your system. Updated BIOS files are located on our website at <http://www.supermicro.com>.

Check the BIOS warning message and information on how to update your BIOS on our website. Select your motherboard model and download the BIOS file to your computer. Also, check the current BIOS revision to make sure that it is newer than your BIOS before downloading. Download the zip file and save the BIOS package to your computer. If you choose the zip BIOS file, unzip the BIOS file onto a bootable USB device. Run the batch file using the format FLASH.BAT filename.rom from your bootable USB device to flash the BIOS. Then, your system will automatically reboot.

Question: Why can't I turn off the power using the momentary power on/off switch?

Answer: The instant power off function is controlled by the Power Button Mode setting in BIOS . When the On/Off feature is enabled, the motherboard will have instant off capabilities as long as the BIOS has control of the system. When the 4 Seconds Override feature is enabled or when the BIOS is not in control such as during memory count (the first screen that appears when the system is turned on), the momentary on/off switch must be held for more than four seconds to shutdown the system. This feature is required to implement the ACPI features on the motherboard.

3.4 Returning Merchandise for Service

A receipt or copy of your invoice marked with the date of purchase is required before any warranty service will be rendered. You can obtain service by calling your vendor for a Returned Merchandise Authorization (RMA) number. When returning to the manufacturer, the RMA number should be prominently displayed on the outside of the shipping carton and mailed prepaid or hand-carried. Shipping and handling charges will be applied for all orders that must be mailed when service is complete.

For faster service, RMA authorizations may be requested online (<http://www.supermicro.com/support/rma/>).

This warranty only covers normal consumer use and does not cover damages incurred in shipping or from failure due to the alteration, misuse, abuse or improper maintenance of products.

During the warranty period, contact your distributor first for any product problems.

3.5 Battery Removal and Installation

Battery Removal

To remove the onboard battery, follow the steps below:

1. Power off your system and unplug your power cable.
2. Locate the onboard battery (see Figure 3-1).
3. Using a tool such as a pen or a small screwdriver, push the battery lock outwards to unlock it. Once unlocked, the battery will pop out from the holder.
4. Remove the battery.

Proper Battery Disposal

Handle used batteries carefully. Do not damage the battery in any way; a damaged battery may release hazardous materials into the environment. Do not discard a used battery in the garbage or a public landfill. Comply with the regulations set up by your local hazardous waste management agency to dispose of your used battery properly.

Battery Installation

1. To install an onboard battery, follow steps 1 and 2 in the Battery Removal section and continue below:
2. Identify the battery's polarity. The positive (+) side should be facing up.
3. Insert the battery into the battery holder and push it down until you hear a click to ensure that the battery is securely locked.

Important: When replacing a battery, be sure to only replace it with the same type.

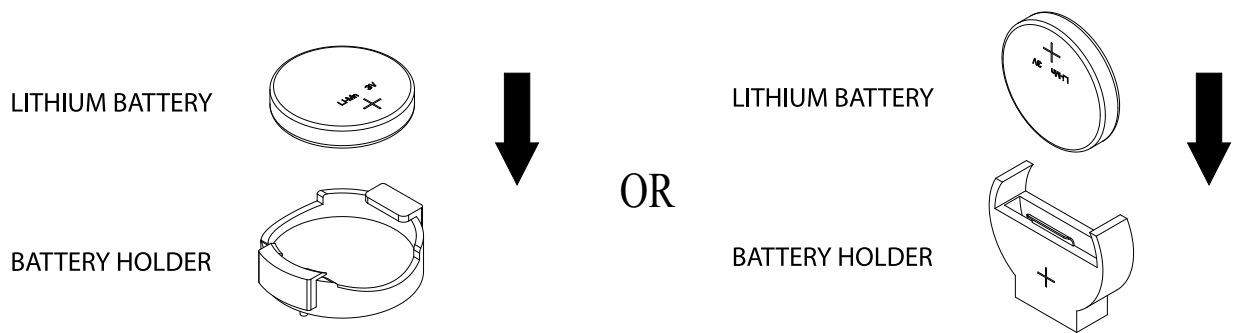

Figure 3-1. Battery Installation

Chapter 4

UEFI BIOS

4.1 Introduction

This chapter describes the AMIBIOS™ Setup utility for the H13DSG-OM motherboard. The BIOS is stored on a chip and can be easily upgraded using a flash program.

Note: Due to periodic changes to the BIOS, some settings may have been added or deleted and might not yet be recorded in this manual. Refer to the Manual Download area of our website for any changes to BIOS that may not be reflected in this manual.

Starting the Setup Utility

To enter the BIOS Setup Utility, hit the <Delete> key while the system is booting-up. (In most cases, the <Delete> key is used to invoke the BIOS setup screen. There are a few cases when other keys are used, such as <F1>, <F2>, etc.) Each main BIOS menu option is described in this manual.

The Main BIOS screen has two main frames. The left frame displays all the options that can be configured. The “grayed-out” options cannot be configured. The right frame displays the key legend. Above the key legend is an area reserved for a text message. When an option is selected in the left frame, it is highlighted in white. Often a text message will accompany it. (Note that BIOS has default text messages built in. We retain the option to include, omit, or change any of these text messages.) Settings printed in **Bold** are the default values.

A " ►" indicates a submenu. Highlighting such an item and pressing the <Enter> key will open the list of settings within that submenu.

The BIOS setup utility uses a key-based navigation system called hot keys. Most of these hot keys (<F1>, <F2>, <F3>, <F4>, <Enter>, <ESC>, <Arrow> keys, etc.) can be used at any time during the setup navigation process.

4.2 Main Setup

When you first enter the AMI BIOS setup utility, you will enter the Main setup screen. You can always return to the Main setup screen by selecting the Main tab on the top of the screen. The Main BIOS setup screen is shown below. The following Main menu items will be displayed:

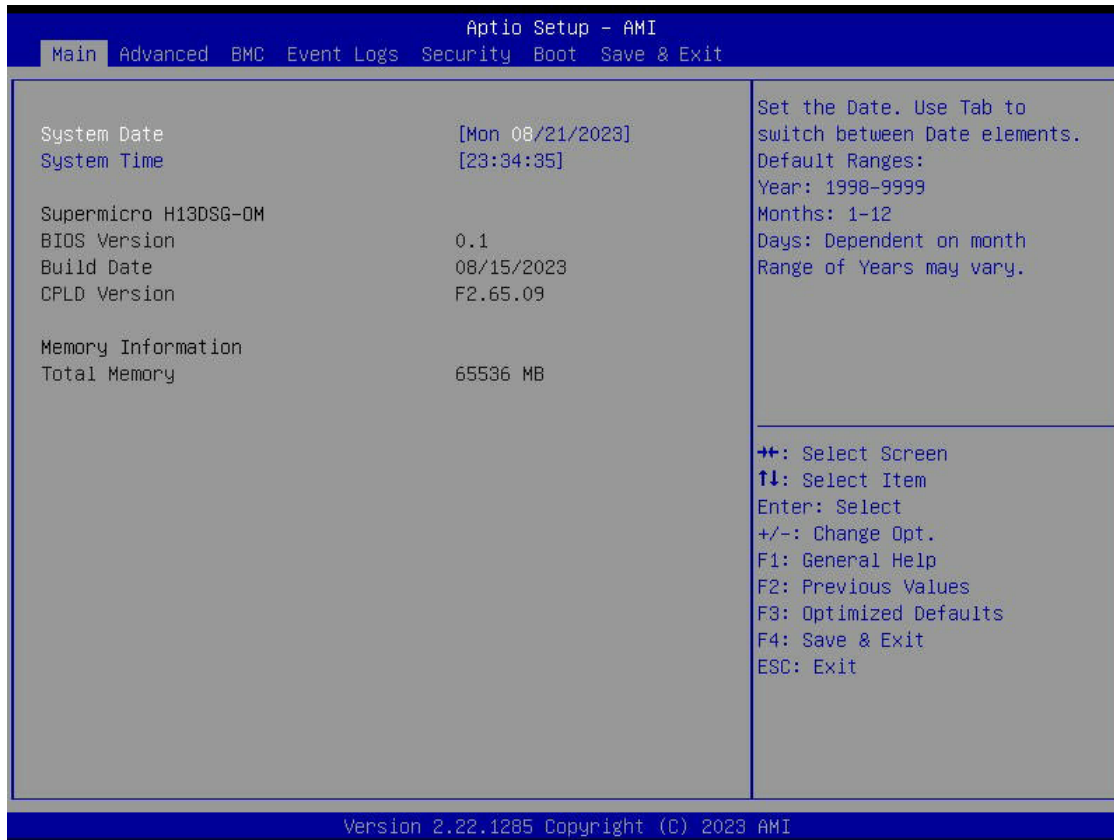

System Date/System Time

Use this option to change the system date and time. To change system date and time settings, highlight *System Date* or *System Time* using the arrow keys and enter new values using the keyboard. Press the <Tab> key or the arrow keys to move between fields. The date must be entered in MM/DD/YYYY format. The time is entered in HH:MM:SS format.

Note: The time is in the 24-hour format. For example, 5:30 P.M. appears as 17:30:00. The date's default value is 01/01/2015 after RTC reset.

Supermicro H13DSG-OM

BIOS Version

This item displays the version of the BIOS ROM used in the system.

Build Date

This item displays the date when the version of the BIOS ROM used in the system was built.

CPLD Version

This item displays the CPLD version of the BIOS ROM used in the system.

Memory Information

Total Memory

This item displays the total size of memory available in the system.

4.3 Advanced

Use the arrow keys to select Boot Setup and press <Enter> to access the submenu items.

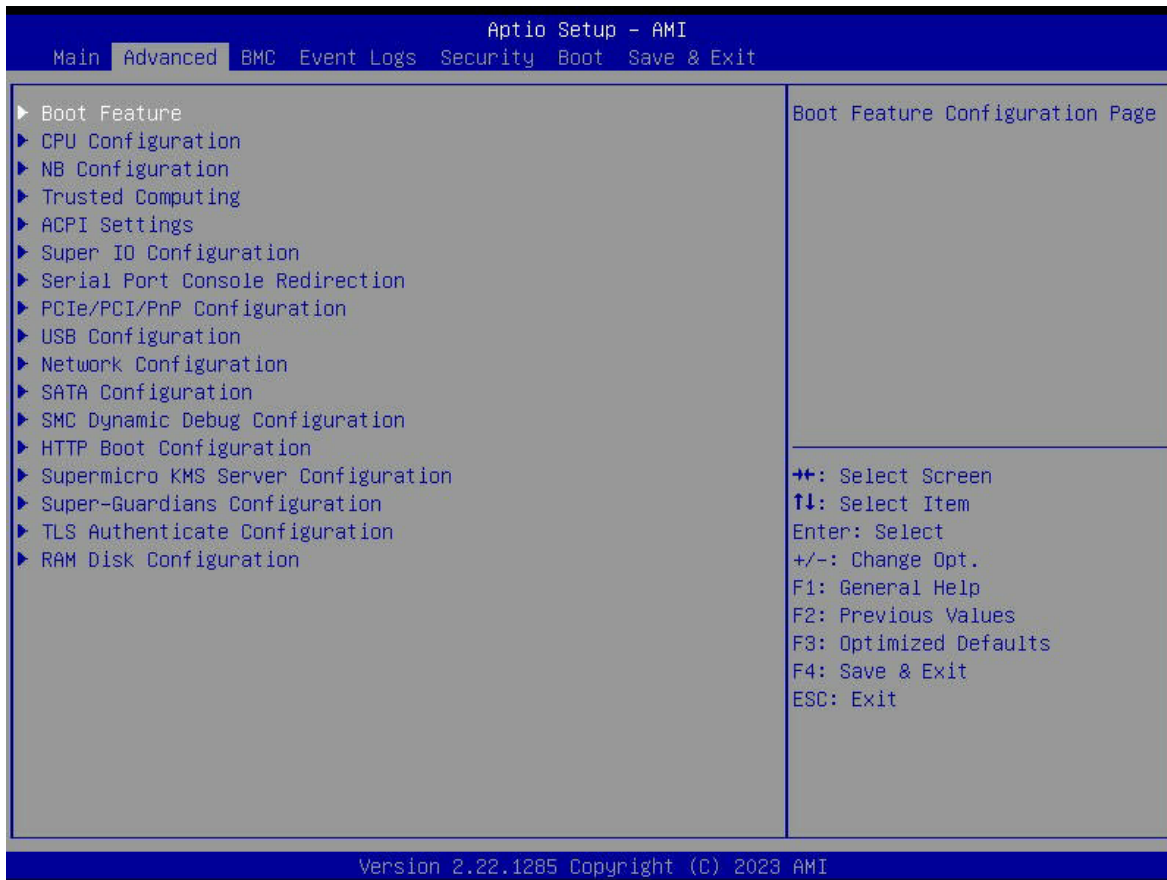

Warning: Take caution when changing the Advanced settings. An incorrect value, a very high DRAM frequency, or an incorrect DRAM timing setting may make the system unstable. When this occurs, revert to the default to the manufacture default settings.

► Boot Feature

Quiet Boot

Use this feature to select the screen display between the Power-on Self Test (POST) messages and the OEM logo upon bootup. Select Disabled to display the POST messages. Select Enabled to display the OEM logo instead of the normal POST messages. The options are Disabled and **Enabled**.

Option ROM Messages

Use this feature to set the display mode for the Option ROM. Select Keep Current to display the current AddOn ROM setting. Select Force BIOS to use the Option ROM display set by the system BIOS. The options are **Force BIOS** and Keep Current.

Bootup NumLock State

Use this feature to set the Power on state for the <Numlock> key. The options are **On** and Off.

Wait For "F1" If Error

Use this feature to force the system to wait until the <F1> key is pressed if an error occurs. The options are Disabled and **Enabled**.

INT19 Trap Response

Interrupt 19 is the software interrupt that handles the boot disk function. When this item is set to Immediate, the ROM BIOS of the host adaptors will "capture" Interrupt 19 at bootup immediately and allow the drives that are attached to these host adaptors to function as bootable disks. If this item is set to Postponed, the ROM BIOS of the host adaptors will not capture Interrupt 19 immediately and allow the drives attached to these adaptors to function as bootable devices at bootup. The options are **Immediate** and Postponed.

Re-try Boot

If this item is enabled, the BIOS will automatically reboot the system from a specified boot device after its initial boot failure. The options are **Disabled**, Legacy Boot, and EFI Boot.

Power Configuration**Watch Dog Function**

If enabled, the Watch Dog Timer will allow the system to reset or generate NMI based on jumper settings when it is expired for more than 5 minutes. The options are **Disabled** and Enabled.

Restore on AC Power Loss

Use this feature to set the power state after a power outage. Select Stay-Off for the system power to remain off after a power loss. Select Power-On for the system power to be turned on after a power loss. Select Last State to allow the system to resume its last power state before a power loss. The options are Stay Off, Power On and **Last State**.

Power Button Function

This feature controls how the system shuts down when the power button is pressed. Select Instant Off to instantly power off the system as soon as the user presses the power button. Select 4 Seconds Override for the user to power off the system after pressing and holding the power button for 4 seconds or longer. The options are **Instant Off** and 4 Seconds Override.

► CPU Configuration

CPU Configuration

SMT Control

Use this setting to specify Simultaneous Multithreading. The options include Disabled, Enabled and **Auto**.

Core Performance Boost

This setting is used to configure for Core Performance Boost. The options include Disabled and **Auto**.

Global C-state Control

This setting is used to configure for Global C-state Control. The options include Disabled, Enabled and **Auto**.

SEV-ES ASID Space Limit

SEV-ES and SNP guests must use ASIDs in the range 1 through (this value -1). SEV guests must use ASIDs in the range of this value through 1006. To have all ASIDs support SEV-ES or SNP guests, set this value to 1007. The default is 1: all SEV guests and no SEV-ES or SNP guests.

PPIN Opt-in

The Protected Processor Identification Number (PPIN) is a unique serial number for each processor. The options include Disabled, Enabled and **Auto**.

SNP Memory (RMP Table) Coverage

Select Enabled to set the entire system memory covered. The options include Disabled, Enabled, Custom and **Auto**.

SMEE

This feature sets the option to enable or disable Secure Memory Encryption. The options are Disabled, Enabled and **Auto**.

Fast Short REP MOVSB (FSRM)

The default value is 1. The options are Disabled, Enabled and **Auto**.

Enhanced REP MOVSB/STOSB (ERSM)

AVX512

The options include Disabled, Enabled, and **Auto**.

Monitor and MWAIT Disable

Select Enable to support Monitor and Mwait. MWAIT instruction provides hints to allow the processor to enter an implementation-dependent optimized state. The options include Enabled, Disabled and **Auto**.

L1 Stream HW Prefetcher

This setting is used to enable or disable the L1 Stream Hardware Prefetcher. The options are Disabled, Enabled and **Auto**.

L2 Stream HW Prefetcher

This setting is used to enable or disable the L2 Stream Hardware Prefetcher. The options are Disabled, Enabled and **Auto**.

CCD Control

Use this setting to disable CCDs in the CPU. The options include **Auto**, 2 CCDs, 4 CCDs, 6 CCDs, 8 CCDs and 10 CCDs.

Core Control

This sets the number of cores to be used by your system. Once this option has been used to remove any cores, a power cycle is required in order for the future selections to take effect. The options include **Auto**, One (1+0), TWO (2+0), THREE (3+0), FOUR (4+0), FIVE (5+0), SIX (6+0), SEVEN (7+0), TWO (1+1), FOUR (2+2), SIX (3+3), EIGHT (4+4), TEN (5+5), ELEVEN (6+5), TWELVE (6+6), FOURTEEN (7+7). If unsure, leave this to Auto.

SVM Mode

SVM refers to Secure Virtual Machine/Virtualization mode. The options include Disabled and **Enabled**.

▶ CPU1 Information

CPU1 Information

These sections are for informational purposes. They will display some details about the detected CPUs on the motherboard, such as:

- CPU Version
- Number of Cores Running
- Processor Family
- Processor Model
- Microcode Patch Level
- L1 Instruction Cache (Size/Method)
- L1 Data Cache (Size/Method)
- L2 Cache (Size/Method)
- L3 Cache per Socket (Size/Method)

CPU1 PCIe Package Group P2

This setting selects the PCIe port bifurcation configuration for the selected slot. The options include **Auto**, x4x4x4x4, x4x4x8, x8x4x4, x8x8 and x16.

CPU1 PCIe Package Group G2

This setting selects the PCIe port bifurcation configuration for the selected slot. The options include **Auto**, x4x4x4x4, x4x4x8, x8x4x4, x8x8 and x16.

CPU1 PCIe Package Group P3

This setting selects the PCIe port bifurcation configuration for the selected slot. The options include **Auto**, x4x4x4x4, x4x4x8, x8x4x4, x8x8 and x16.

CPU1 PCIe Package Group G3

This setting selects the PCIe port bifurcation configuration for the selected slot. The options include **Auto**, x4x4x4x4, x4x4x8, x8x4x4, x8x8 and x16.

CPU1 PCIe Package Group P1

This setting selects the PCIe port bifurcation configuration for the selected slot. The options include **Auto**, x4x4x4x4, x4x4x8, x8x4x4, x8x8 and x16.

CPU1 PCIe Package Group G1

This setting selects the PCIe port bifurcation configuration for the selected slot. The options include **Auto**, x4x4x4x4, x4x4x8, x8x4x4, x8x8 and x16.

CPU1 PCIe Package Group P0

This setting selects the PCIe port bifurcation configuration for the selected slot. The options include **Auto**, x4x4x4x4, x4x4x8, x8x4x4, x8x8 and x16.

CPU1 PCIe Package Group G0

This setting selects the PCIe port bifurcation configuration for the selected slot. The options include **Auto**, x4x4x4x4, x4x4x8, x8x4x4, x8x8 and x16.

► CPU2 Information**CPU2 Information**

These sections are for informational purposes. They will display some details about the detected CPUs on the motherboard, such as:

- CPU Version
- Number of Cores Running
- Processor Family
- Processor Model
- Microcode Patch Level

- L1 Instruction Cache (Size/Method)
- L1 Data Cache (Size/Method)
- L2 Cache (Size/Method)
- L3 Cache per Socket (Size/Method)

CPU2 PCIe Package Group P2

This setting selects the PCIe port bifurcation configuration for the selected slot. The options include **Auto**, x4x4x4x4, x4x4x8, x8x4x4, x8x8 and x16.

CPU2 PCIe Package Group G2

This setting selects the PCIe port bifurcation configuration for the selected slot. The options include **Auto**, x4x4x4x4, x4x4x8, x8x4x4, x8x8 and x16.

CPU2 PCIe Package Group P3

This setting selects the PCIe port bifurcation configuration for the selected slot. The options include **Auto**, x4x4x4x4, x4x4x8, x8x4x4, x8x8 and x16.

CPU2 PCIe Package Group G3

This setting selects the PCIe port bifurcation configuration for the selected slot. The options include **Auto**, x4x4x4x4, x4x4x8, x8x4x4, x8x8 and x16.

CPU2 PCIe Package Group P1

This setting selects the PCIe port bifurcation configuration for the selected slot. The options include **Auto**, x4x4x4x4, x4x4x8, x8x4x4, x8x8 and x16.

CPU2 PCIe Package Group G1

This setting selects the PCIe port bifurcation configuration for the selected slot. The options include **Auto**, x4x4x4x4, x4x4x8, x8x4x4, x8x8 and x16.

CPU2 PCIe Package Group P0

This setting selects the PCIe port bifurcation configuration for the selected slot. The options include **Auto**, x4x4x4x4, x4x4x8, x8x4x4, x8x8 and x16.

CPU2 PCIe Package Group G0

This setting selects the PCIe port bifurcation configuration for the selected slot. The options include **Auto**, x4x4x4x4, x4x4x8, x8x4x4, x8x8 and x16.

► NB Configuration

North Bridge Configuration

IOMMU

Use this setting to enable/disable IOMMU. The options include Disabled, Enabled, and **Auto**.

DMAr Support

Enable DMAr system protection during POST. The options include Disabled, Enabled and **Auto**.

DMA Protection

Enable DMA remap support in IVRS IVinfo Field. The options include **Auto**, Enabled and Disabled.

DRTM Virtual Device Support

Enable DRTM ACPI virtual device. The options include Disabled, Enabled and **Auto**.

ACS Enable

Use this setting to enable/disable ACS. The options include Enabled, Disabled and **Auto**.

TDP Control

Use this setting to configure the TDP Control. The options include Manual and **Auto**.

Package Power Limit Control

Use this setting for Package Power Limit Control. The options include Manual and **Auto**.

Determinism Control

Use this setting to configure the Determinism Slider. The options include Manual and **Auto**.

APBDIS

APBDIS is an IO Boost disable on uncore. For any system user that needs to block these uncore optimizations that are impacting base core clock speed. The options include 0, 1 and **Auto**.

Power Profile Selection

The options include **High Performance Mode**, Efficiency Mode and Maximum IO Performance Mode.

DF C-Stats

Use this setting to enable/disable DF Cstates. The options include Disabled, Enabled, and **Auto**.

Data Link Feature Cap

Use this setting to set Data Link Feature Cap. The options include Enabled, Disabled and **Auto**.

SEV-SNP Support

Use this setting for SEV-SNP Support. The options include Disabled, Enabled and **Auto**.

Periodic Training

Use this setting to specify Periodic Training configuration. The options include **Auto**, Enabled, and Disabled.

EQ Bypass To Highest Rate

Use this setting to control the ability to advertise Equalization Bypass to Highest Rate Support in TSxs sent prior to LinkUp=1. The options include Disabled, Enabled and **Auto**.

CXL SPM

Use this setting to set CXL memory as Special Purpose Memory. The options include **Auto**, Enabled, and Disabled.

Sync Header Bypass

Use this setting to enable or disable CXL Sync Header Bypass Support. The options include **Auto**, Enabled, and Disabled.

► xGMI Configuration

xGMI Link Width Control

Use this setting to use or customize the default xGMI link width controller settings. The options include Manual and **Auto**.

xGMI Link Max Speed

Use this setting to select xGMI Link Max Speed. The options include 10.667Gbps ,11Gbps, 12Gbps, 13Gbps, 14Gbps, 15Gbps, 16Gbps, 17Gbps, 18Gbps, 19Gbps, 20Gbps, 21Gbps, 22Gbps, and **Auto**.

► Memory Configuration

Memory Configuration

Memory Target Speed

Use this feature to set the memory target speed. The options include **Auto**, DDR3200, DDR3600, DDR4000, DDR4400, DDR4800, DDR5200, DDR5600, and DDR6000.

Memory Interleaving

This setting controls fabric level memory interleaving. Note that the channel, die and socket have requirements on memory populations and it will be ignored if the memory doesn't support the selected option. The options include Disabled and **Auto**.

Chipset Interleaving

This setting controls interleave memory blocks across the DRAM chip for node 0. The options are Disabled and **Auto**.

BankSwapMode

This setting controls the Bank Swap Mode. The options are **Auto**, Disabled and Swap CPU.

Power Down Enable

Use this setting to enable or disable DDR power down mode. The options are Disabled, Enabled and **Auto**.

DRAM Scrub Time

This setting provides a value that is the number of hours to scrub memory. The options are **Disabled**, 1 hour, 4 hours, 6 hours, 8 hours, 12 hours, 16 hours, 24 hours, 48 hours, and Auto.

TSME

Transparent SME. The options are Disabled, Enabled, and **Auto**.

Enhanced PPR

Enable a full memory test. The testing will increase the boot time. The options are **Disabled** and Enabled.

► CPU1 Memory Information**CPU1 Memory Information**

These sections are for informational purposes. They will display some details about the detected memory according to each CPU on the motherboard, such as:

- Detected Size (per slot, in MB)
- Current Speed (MT/s)

► CPU2 Memory Information**CPU2 Memory Information**

These sections are for informational purposes. They will display some details about the detected memory according to each CPU on the motherboard, such as:

- Detected Size (per slot, in MB)
- Current Speed (MT/s)

▶ Trusted Computing

Configuration

Security Device Support

If this feature and the TPM jumper on the motherboard are both set to Enabled, onboard security devices will be enabled for TPM (Trusted Platform Module) support to enhance data integrity and network security. Reboot the system for the changes to take effect. The options are Disabled and **Enabled**.

Disable Block SID

Disable this function to allow SID authentication in a TCG Storage device. The options include Enabled and **Disabled**.

▶ ACPI Settings

ACPI Settings

High Precision Event Timer

The High Precision Event Timer (HPET) can produce periodic interrupts and is used to synchronize multimedia streams, providing smooth playback and reducing the need to use other timestamp calculations. The options are Disabled and **Enabled**.

PCI AER Support

Enables Advanced error reporting capability. The options are **Disabled** and Enabled.

NUMA Nodes Per Socket

Use this feature to specify the number of desired NUMA nodes per socket. The options are NPS0, NPS1, NPS2, NPS4, and **Auto**.

ACPI SRAT L3 Cache As NUMA Domain

Use this setting to enable/disable ACPI SRAT L3 Cache As NUMA Domain. The options are Disabled, Enabled, and **Auto**.

▶ Super IO Configuration

Super IO Configuration

The following Super IO information will display:

- Super IO Chip AST2600

▶ Serial Port 1 Configuration

Serial Port 1 Configuration

Serial Port 1

Select Enabled to enable the selected onboard serial port. The options are Disabled and Enabled.

Change Settings

This feature specifies the base I/O port address and the Interrupt Request address of a serial port specified by the user. Select Auto to allow the BIOS to automatically assign the base I/O and IRQ address. The options are **Auto**, (IO=3F8h; IRQ=4;), (IO=3F8h; IRQ=3,4,5,6,7,8,9,10,11,12;), (IO=2F8h; IRQ=3,4,5,6,7,8,9,10,11,12;), (IO=3E8h; IRQ=3,4,5,6,7,8,9,10,11,12;) and (IO=2E8h; IRQ=3,4,5,6,7,8,9,10,11,12;).

► Serial Port 2 Configuration

Serial Port 2 Configuration

Serial Port 2

Select Enabled to enable the selected onboard serial port. The options are Disabled and Enabled.

Change Settings

This feature specifies the base I/O port address and the Interrupt Request address of a serial port specified by the user. Select Auto to allow the BIOS to automatically assign the base I/O and IRQ address. The options are **Auto**, (IO=2F8h; IRQ=3;), (IO=3F8h; IRQ=3;), (IO=3E8h; IRQ=3;) and (IO=2E8h; IRQ=3;).

Serial Port 2 Attribute

The options are **SOL** and COM.

► Serial Port Console Redirection

COM1

Console Redirection

Select Enabled to enable console redirection support for a serial port specified by the user. The options are **Disabled** and Enabled.

Console Redirection Settings

Terminal Type

This feature allows the user to select the target terminal emulation type for Console Redirection. Select VT100 to use the ASCII Character set. Select VT100+ to add color

and function key support. Select ANSI to use the Extended ASCII Character Set. Select VT-UTF8 to use UTF8 encoding to map Unicode characters into one or more bytes. The options are VT100, **VT100+**, VT-UTF8 and ANSI.

Bits Per Second

Use this feature to set the transmission speed for a serial port used in Console Redirection. Make sure that the same speed is used in the host computer and the client computer. A lower transmission speed may be required for long and busy lines. The options are 9600, 19200, 38400, 57600 and **115200** (bits per second).

Data Bits

Use this feature to set the data transmission size for Console Redirection. The options are 7 and **8**.

Parity

A parity bit can be sent along with regular data bits to detect data transmission errors. Select Even if the parity bit is set to 0, and the number of 1's in data bits is even. Select Odd if the parity bit is set to 0, and the number of 1's in data bits is odd. Select None if you do not want to send a parity bit with your data bits in transmission. Select Mark to add a mark as a parity bit to be sent along with the data bits. Select Space to add a Space as a parity bit to be sent with your data bits. The options are **None**, Even, Odd, Mark and Space.

Stop Bits

A stop bit indicates the end of a serial data packet. Select 1 Stop Bit for standard serial data communication. Select 2 Stop Bits if slower devices are used. The options are **1** and 2.

Flow Control

Use this feature to set the flow control for Console Redirection to prevent data loss caused by buffer overflow. Send a "Stop" signal to stop sending data when the receiving buffer is full. Send a "Start" signal to start sending data when the receiving buffer is empty. The options are **None** and Hardware RTS/CTS.

VT-UTF8 Combo Key Support

Select Enabled to enable VT-UTF8 Combination Key support for ANSI/VT100 terminals. The options are Disabled and **Enabled**.

Recorder Mode

Select Enabled to capture the data displayed on a terminal and send it as text messages to a remote server. The options are **Disabled** and Enabled.

Resolution 100x31

Select Enabled for extended-terminal resolution support. The options are Disabled and **Enabled**.

Putty KeyPad

This feature selects the settings for Function Keys and KeyPad used for Putty, which is a terminal emulator designed for the Windows OS. The options are **VT100**, LINUX, XTERMR6, SC0, ESCN and VT400.

SOL

Console Redirection

Select Enabled to enable console redirection support for a serial port specified by the user. The options are Disabled and **Enabled**.

► Console Redirection Settings

Terminal Type

This feature allows the user to select the target terminal emulation type for Console Redirection. Select VT100 to use the ASCII Character set. Select VT100+ to add color and function key support. Select ANSI to use the Extended ASCII Character Set. Select VT-UTF8 to use UTF8 encoding to map Unicode characters into one or more bytes. The options are VT100, **VT100+**, VT-UTF8 and ANSI.

Bits Per Second

Use this feature to set the transmission speed for a serial port used in Console Redirection. Make sure that the same speed is used in the host computer and the client computer. A lower transmission speed may be required for long and busy lines. The options are 9600, 19200, 38400, 57600 and **115200** (bits per second).

Data Bits

Use this feature to set the data transmission size for Console Redirection. The options are 7 and **8**.

Parity

A parity bit can be sent along with regular data bits to detect data transmission errors. Select Even if the parity bit is set to 0, and the number of 1's in data bits is even. Select Odd if the parity bit is set to 0, and the number of 1's in data bits is odd. Select None if you do not want to send a parity bit with your data bits in transmission. Select Mark to add a mark as a parity bit to be sent along with the data bits. Select Space to add a Space as a parity bit to be sent with your data bits. The options are **None**, Even, Odd, Mark and Space.

Stop Bits

A stop bit indicates the end of a serial data packet. Select 1 Stop Bit for standard serial data communication. Select 2 Stop Bits if slower devices are used. The options are **1** and 2.

Flow Control

Use this feature to set the flow control for Console Redirection to prevent data loss caused by buffer overflow. Send a "Stop" signal to stop sending data when the receiving buffer is full. Send a "Start" signal to start sending data when the receiving buffer is empty. The options are **None** and Hardware RTS/CTS.

VT-UTF8 Combo Key Support

Select Enabled to enable VT-UTF8 Combination Key support for ANSI/VT100 terminals. The options are Disabled and **Enabled**.

Recorder Mode

Select Enabled to capture the data displayed on a terminal and send it as text messages to a remote server. The options are **Disabled** and Enabled.

Resolution 100x31

Select Enabled for extended-terminal resolution support. The options are Disabled and **Enabled**.

Putty KeyPad

This feature selects the settings for Function Keys and KeyPad used for Putty, which is a terminal emulator designed for the Windows OS. The options are **VT100**, LINUX, XTERMR6, SC0, ESCN and VT400.

Legacy Console Redirection Settings**Legacy Serial Redirection Port**

For this setting, select a COM port to display redirection of Legacy OS and Legacy OPRM messages. The options include COM1 and SOL.

Resolution 100x31

Select Enabled for extended-terminal resolution support. The options are Disabled and **Enabled**.

Redirection After BIOS POST

When Bootloader is selected, then Legacy Console Redirection is disabled before booting to legacy OS. When Always Enable is selected, then Legacy Console Redirection is enabled or legacy OS. The default setting is set to Always Enable. The options include Always Enable and BootLoader.

Serial Port for Out-of-Band Management/**Windows Emergency Management Services (EMS)**

Console Redirection EMS

Select Enabled to enable EMS console redirection support for a serial port specified by the user. The options are **Disabled** and Enabled.

► PCIe/PCI/PnP Configuration

This menu provides PCIe/PCI/PnP configuration settings and information.

PCI Bus Driver Version

PCI Devices Common Settings:

Above 4G Decoding

This setting Disables or **Enables** 64-bit capable devices ability to be decoded in above 4G address space (only if the system supports 64-bit PCI decoding). The options are Disabled and **Enabled**.

Re-Size BAR Support

If system has resizable BAR capable PCIe devices, this option Enables or **Disables** resizable BAR support.

SR-IOV Support

If the system has SR-IOV capable PCIe devices, this setting will **Disable** or Enable the Single Root IO Virtualization Support for the system.

BME DMA Mitigation

Re-enable Bus Master Attribute disabled during PCI enumeration for PCI Bridges after SMM Locked. The options are **Disabled** and Enabled.

PCIe Speed PMM Control

Reduce the link speed when devices are idle. The options are Dynamic link speed determined by Power Management functionality, Static Target Link Speed (GEN4), Static Target Link Speed (GEN5) and **Auto**.

ASPM Support

Use this setting to set the ASPM level. The options are **Disabled**, Auto and Force L1.

PCIe ARI Support

Use this setting to Disable, Enable or **Auto** control the Alternative Routing-ID Interpretation.

PCIe ARI Enumeration

Use this setting to Disable, Enable or **Auto** control the ARI Forwarding Enable for each downstream port.

Relaxed Ordering

Select Enable to enable Relaxed Ordering support, which will allow certain transactions to violate the strict-ordering rules of PCI bus for a transaction to be completed prior to other transactions that have already been enqueued. The options are Disabled and **Enabled**.

Clock Spread Spectrum

Use this setting to Disable or Enable CG1_PLL Spread Spectrum for your system. The options are **Disabled** and Enabled.

No Snoop

Select Enable to support no-snoop mode for each CB device. The options are Disabled and **Enabled**.

VGA Priority

Use this setting to select between onboard or external VGA support. The options are **Onboard** and External.

PCIe Ten Bit Tag Support

Use this setting to Disable, Enable or **Auto** control the PCIe ten bit tags for supported devices.

NVMe Firmware Source

Use this setting to select between the AMI Native firmware support or the device vendor-defined firmware support. The options are **Vendor Defined Firmware** and AMI Native Support.

PCI Devices Option Rom Setting**CPU SLOT1 PCIe 5.0 x16 OPROM**

This setting enables or disables PCIe SLOT1 OPROM option. The options include Disabled and **EFI**.

CPU SLOT2 PCIe 5.0 x16 OPROM

This setting enables or disables PCIe SLOT2 OPROM option. The options include Disabled and **EFI**.

CPU SLOT3 PCIe 5.0 x16 OPROM

This setting enables or disables PCIe SLOT3 OPROM option. The options include Disabled and **EFI**.

CPU SLOT4 PCIe 5.0 x16 OPROM

This setting enables or disables PCIe SLOT4 OPROM option. The options include Disabled and **EFI**.

CPU SLOT5 PCIe 5.0 x16 OPROM

This setting enables or disables PCIe SLOT5 OPROM option. The options include Disabled and **EFI**.

CPU SLOT6 PCIe 5.0 x16 OPROM

This setting enables or disables PCIe SLOT6 OPROM option. The options include Disabled and **EFI**.

CPU SLOT7 PCIe 5.0 x16 OPROM

This setting enables or disables PCIe SLOT7 OPROM option. The options include Disabled and **EFI**.

CPU SLOT8 PCIe 5.0 x16 OPROM

This setting enables or disables PCIe SLOT8 OPROM option. The options include Disabled and **EFI**.

CPU SLOT9 PCIe 5.0 x16 OPROM

This setting enables or disables PCIe SLOT9 OPROM option. The options include Disabled and **EFI**.

CPU SLOT10 PCIe 5.0 x16 OPROM

This setting enables or disables PCIe SLOT10 OPROM option. The options include Disabled and **EFI**.

CPU SLOT11 PCIe 5.0 x16 OPROM

This setting enables or disables PCIe SLOT11 OPROM option. The options include Disabled and **EFI**.

CPU SLOT12 PCIe 5.0 x16 OPROM

This setting enables or disables PCIe SLOT12 OPROM option. The options include Disabled and **EFI**.

Onboard Video Option ROM

Select Legacy to boot the system using a legacy video device installed on the motherboard. The options include Disabled and **EFI**.

AIOM OPROM

This setting enables or disables Onboard LAN OPROM option. The options include Disabled and **EFI**.

► USB Configuration

Legacy USB Support

Select Enabled to support onboard legacy USB devices. Select Auto to disable legacy support if there are no legacy USB devices present. Select Disable to have all USB devices available for EFI applications only. The options are **Enabled**, Disabled and Auto.

XHCI Hand-Off

This is a work-around solution for operating systems that do not support XHCI (Extensible Host Controller Interface) hand-off. The XHCI ownership change should be claimed by the XHCI driver. The options are Enabled and **Disabled**.

Port 60/64 Emulation

Select Enabled for I/O port 60h/64h emulation support, which in turn, will provide complete legacy USB keyboard support for the operating systems that do not support legacy USB devices. The options are Disabled and **Enabled**.

► Network Configuration

Network Stack

This setting allows you to Disable or **Enable** the UEFI Network Stack.

IPv4 PXE Support

This setting allows you to Disable or **Enable** IPv4 PXE boot support. If disabled, IPv4 PXE boot support will not be available.

IPv4 HTTP Support

This setting allows you to **Disable** or Enable IPv4 HTTP boot support. If disabled, IPv4 HTTP boot support will not be available.

IPv6 PXE Support

This setting allows you to Disable or **Enable** IPv6 PXE boot support. If disabled, IPv6 PXE boot support will not be available.

IPv6 HTTP Support

This setting allows you to **Disable** or Enable IPv6 HTTP boot support. If disabled, IPv6 HTTP boot support will not be available.

PXE Boot Wait Time

This setting allows you to set in a number field the wait time to press the ESC key to abort the PXE boot. The default value is **0**.

Media Detect Count

This setting allows you set in a number field the number of times presence of media will be checked. The default value is **1**.

▶ SATA Configuration

This section displays the detected SATA devices installed on the system.

ASMedia SATA Controller

Use this setting to enable or disable the ASMedia SATA controller. The options include Disabled, IDE and **AHCI**.

Hot-Plug

Use this feature to enable or disable the hot-plug support. The options include **Disabled** and Enabled.

SATA Enable

Use this feature to disable or enable OnChip SATA controller. The options include Disabled, Enabled and **Auto**.

▶ SATA Information

This item displays information on the detected SATA that are connected

▶ HTTP Boot Configuration

HTTP Boot Policy

Sets the HTTP boot policy to Apply to all LANs, **Apply to each LAN**, or Boot Priority #1 instantly.

HTTPS Boot Checks Hostname

Use this feature to select whether HTTPS Boot checks the hostname of TLS certificates matches the hostname provided by the remote server. The options include **Enabled** and Disabled (WARNING: Security Risk!!).

Priority of HTTP Boot

Instance of Priority 1

This configures the order that your computer searches the physical devices for the boot sequence. The default value is **1**.

Select IPv4 or IPv6

Choose to set the targeted LAN port to boot from **IPv4** or IPv6.

Boot Description

This setting must be filled out, otherwise the boot option for the URI cannot be created.

Boot URI

This option is an input field used to enter a web or network address to point to the HTTP boot files. This supports the HTTP or HTTPS protocols only.

► Supermicro KMS Server Configuration**Supermicro KMS Server IP address**

Enter IP4 address in dotted-decimal notation.

Second Supermicro KMS Server IP address

Enter IP4 address in dotted-decimal notation.

Supermicro KMS TCP Port number

Use this feature to enter the SMCI KMS TCP port number. The valid range is 100 - 9999. The default setting is **5696**.

KMS Time Out

Use this feature to enter the KMS server connecting time-out (in seconds). KMS Server connecting time-out, unit is second, in the range of 5~30 seconds. The default value is **5** (seconds).

TimeZone

Use this feature to enter the correct time zone. The default setting is **0** (not specified).

Client UserName

Press <Enter> to set the client identity (UserName). The length is 0 - 63 characters.

Client Password

Press <Enter> to set the client identity (Password). The length is 0 - 31 characters.

KMS TLS Certificate / Size**► CA Certificate**

For the CA certificate, use this feature to enroll factory defaults or load the KMS TLS certificates from the file. The options include Update, Delete and Export.

▶ Client Certificate

For the client certificate, use this feature to enroll factory defaults or load the KMS TLS certificates from the file. The options include Update, Delete and Export.

▶ Client Private Key

For the client private key, use this feature to enroll factory defaults or load the KMS TLS certificates from the file. The options include Update, Delete and Export.

▶ Super-Guardians Configuration

Super-Guardians Protection Policy

The options are **Storage**, System, and System and Storage.

KMS Security Policy

The options are **Disabled**, and Enabled.

KMS Server Retry Count

The test connection to Key Manage Server ranges from 0 to 10. The default value is 5.

TPM Security Policy

The options are **Disabled**, and Enabled.

Load Authentication-Key

The options are **Disabled**, and Enabled.

USB Security Policy

The options are **Disabled**, and Enabled.

▶ TLS Authenticate Configuration

This submenu allows the user to configure Transport Layer Security (TLS) settings.

▶ Enroll Certification

Enroll Certification Using File

Use this feature to enroll certification from a file.

Certification GUID

Use this feature to input the certification GUID.

▶Commit Changes and Exit

Use this feature to save all changes and exit TLS settings.

▶Discard Changes and Exit

Use this feature to discard all changes and exit TLS settings.

▶Delete Certification

Use this feature to enable or disable the deletion of certificate. The options include **Disabled** and Enabled.

▶Driver Health

The setting provides the health status for the Drivers/controllers.

▶RAM Disk Configuration

Disk Memory Type

The options include **Boot Service Data**, and Reserved.

▶Create raw

The options are **Disabled** and Enabled.

▶Create from file

Use this setting to create a RAM disk from a given file.

Remove selected RAM disk(s)

▶Driver Health

▶Broadcom NXE Gigabit Ethernet Driver

Use this setting to view health status of drivers or controllers.

4.4 BMC

This tab allows you to configure the following IPMI settings for the system.

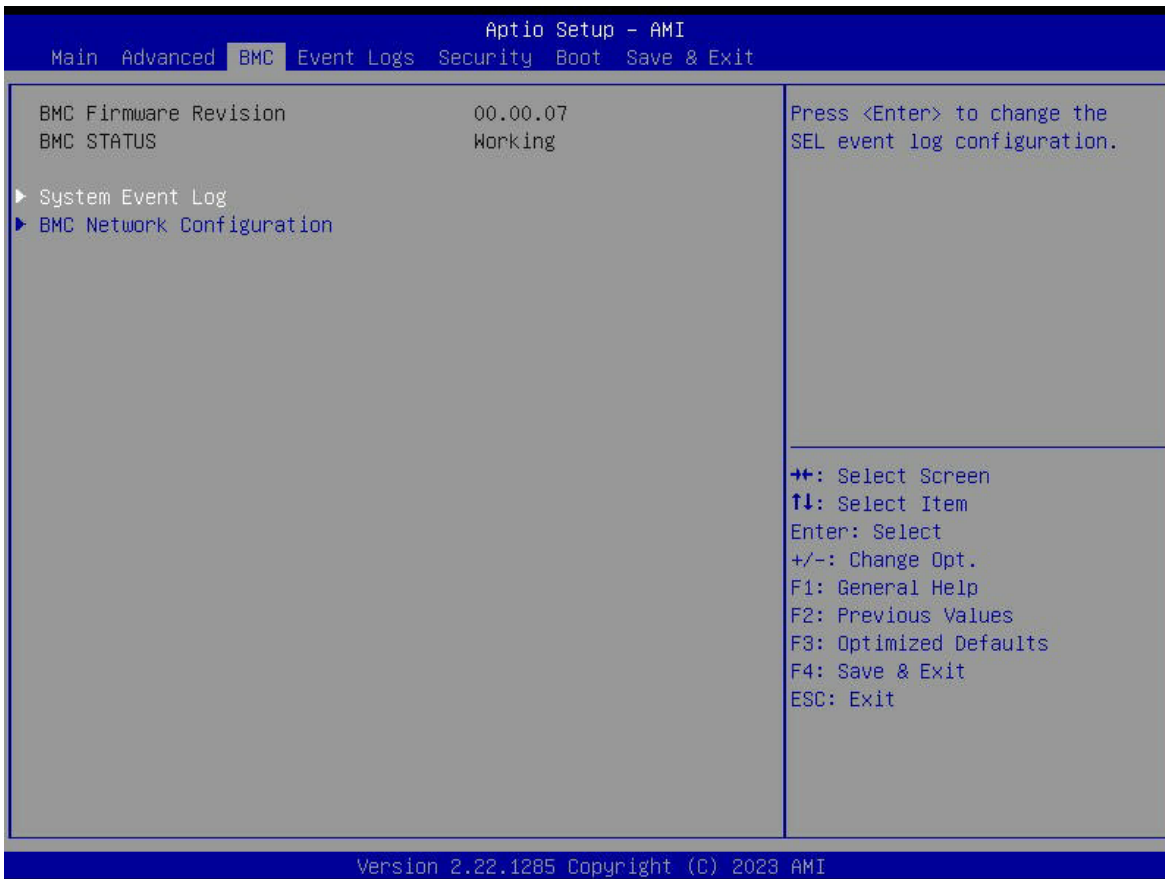

Use this feature to configure Intelligent Platform Management Interface (IPMI) settings.

BMC Firmware Revision

This item indicates the IPMI firmware revision used in your system.

BMC Status

This item indicates the status of the IPMI firmware installed in your system.

▶ System Event Log

Enabling/Disabling The options

SEL Components

Select Enabled for all system event logging at bootup. The options are Disabled and Enabled.

Erasing Settings

Erase SEL

Select Yes, On next reset to erase all system event logs upon next system reboot. Select Yes, On every reset to erase all system event logs upon each system reboot. Select No to keep all system event logs after each system reboot. The options are **No**, Yes, On next reset, and Yes, On every reset.

When SEL is Full

This feature allows the user to decide what the BIOS should do when the system event log is full. Select Erase Immediately to erase all events in the log when the system event log is full. The options are **Do Nothing** and Erase Immediately.

Note: All values changed here do not take effect until computer is restarted.

► BMC Network Configuration

Update BMC LAN Configuration

Select Yes to enable BMC Network Configuration. The options include **No** and Yes.

Configure IPv4 Support

This section displays static configuration features for IPV4 support.

BMC LAN Selection

This item displays the IPMI LAN setting. The default setting is **Failover**.

BMC Network Link Status

This item displays the IPMI Network Link status. The default setting is **Dedicated LAN**.

Configuration Address Source

This feature allows the user to select the source IP address for this computer. If Static is selected, you will need to know the IP address of this computer. If DHCP is selected, the BIOS will search for a DHCP (Dynamic Host Configuration Protocol) server in the network and request the next available IP address for this computer. The default setting is **DHCP**.

Station IP Address

This item displays the Station IP address for this computer. This should be in decimal and in dotted quad form.

Subnet Mask

This item displays the sub-network that this computer belongs to. The value of each three-digit number separated by dots should not exceed 255.

Station MAC Address

This item displays the Station MAC address for this computer. Mac addresses are 6 two-digit hexadecimal numbers.

Gateway IP Address

This item displays the Gateway IP address for this computer. This should be in decimal and in dotted quad form (i.e., 172.31.0.1).

Configure IPv6 Support

This section displays configuration features for IPv6 support.

IPv6 Address status: Active**IPv6 Support**

The default setting is **Enabled**.

Configuration Address Source

This feature allows the user to select the source of the IP address for this computer. If Static is selected, you will need to know the IP address of this computer and enter it to the system manually in the field. If DHCP is selected, the BIOS will search for a DHCP (Dynamic Host Configuration Protocol) server in the network that is attached to and request the next available IP address for this computer. The default setting is **DHCPv6 Stateless**.

IPv6 Address (DHCPv6 Stateless)**Prefix Length: 64****Gateway IP****Advanced Settings**

The default setting is **Auto obtain DNS server IP**.

Preferred DNS server IP**Alternative DNS server IP****Configure VLAN Support****Lan Channel 1****VLAN Support**

This item displays features for virtual LAN support. The options are Enabled, Disabled, and **Unspecified**.

4.5 Event Logs

This tab allows the user to configure the following event logs settings for the system.

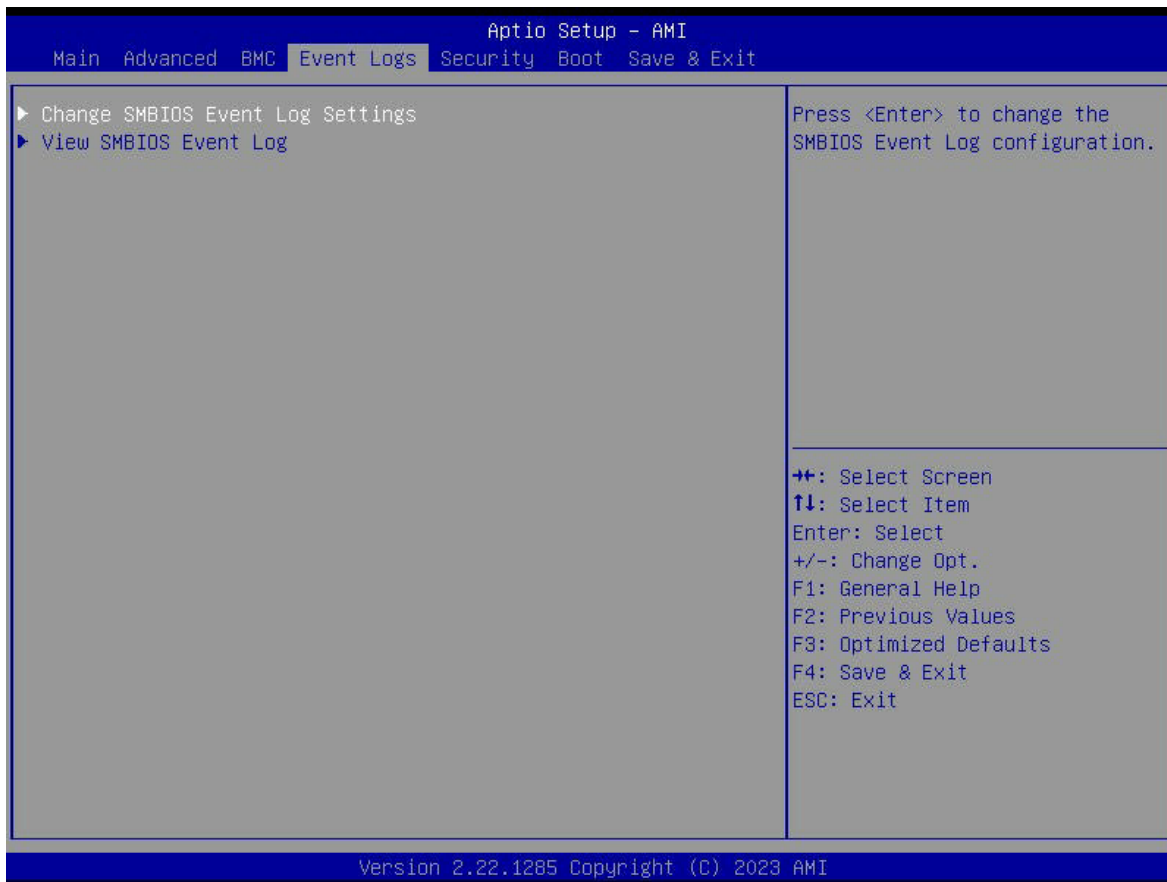

▶ Change SMBIOS Event Log Settings

This feature allows the user to configure SMBIOS Event settings.

Enabling/Disabling The options

SMBIOS Event Log

Select Enabled to enable SMBIOS (System Management BIOS) Event Logging during system boot. The options are Disabled and **Enabled**.

Erasing Settings

Erase Event Log

Select Yes to erase all error events in the SMBIOS (System Management BIOS) log before an event logging is initialized at bootup. The options are **No**, Yes, Next reset, and Yes, Every reset.

When Log is Full

Select Erase Immediately to immediately erase all errors in the SMBIOS event log when the event log is full. Select Do Nothing for the system to do nothing when the SMBIOS event log is full. The options are **Do Nothing** and Erase Immediately.

SMBIOS Event Log Standard Settings

Log System Boot Event

Select Enabled to log system boot events. The options are Enabled and **Disabled**.

MECI (Multiple Event Count Increment)

Enter the increment value for the multiple event counter. Enter a number between 1 to 255. The default setting is **1**.

METW (Multiple Event Count Time Window)

This item is used to determine how long (in minutes) the multiple event counter should wait before generating a new event log. Enter a number between 0 to 99. The default setting is **60**.

Note: All values changed here do not take effect until computer is restarted.

►View SMBIOS Event Log

When Event Logging is on, this item allows the user to view the entries in the SMBIOS event log. The following categories are displayed:

Date / Time / Error Code / Severity

4.6 Security

This tab allows you to configure the following security settings for the system.

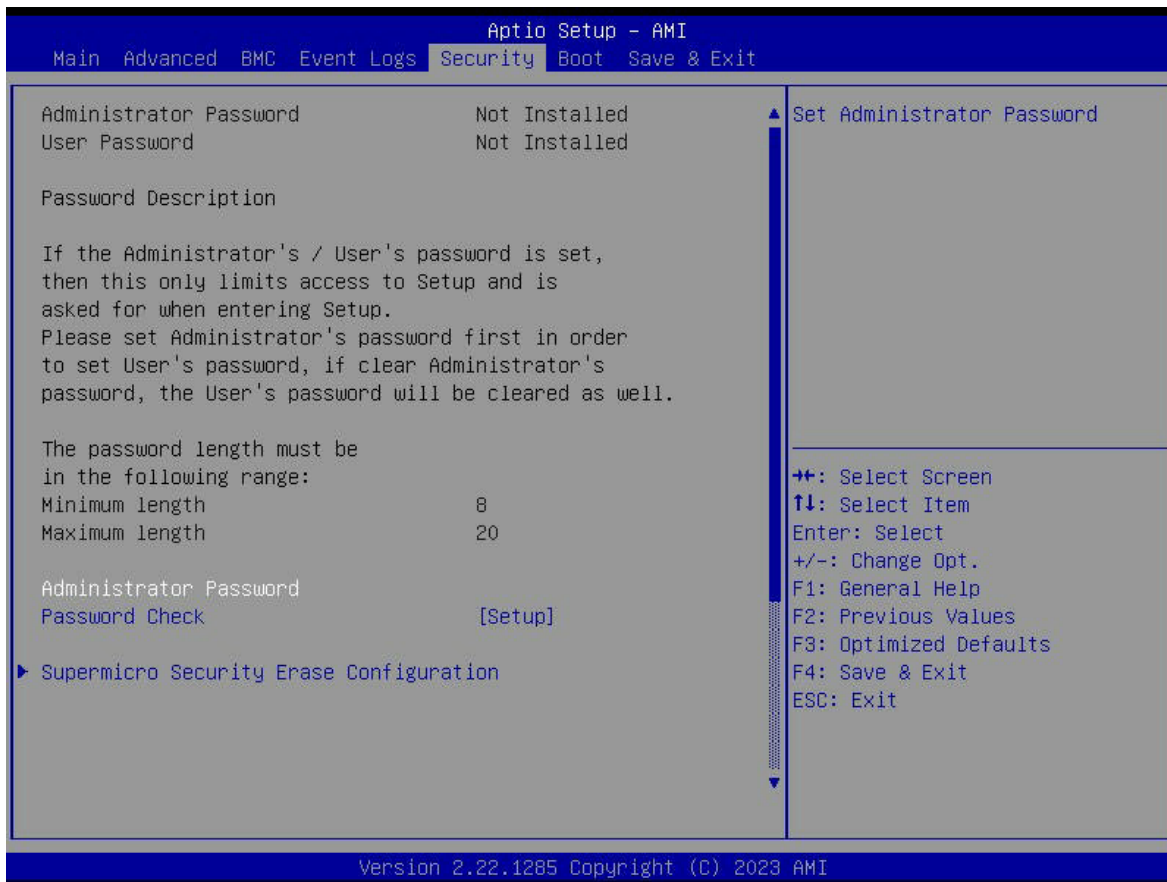

Administrator Password

Press <Enter> to create a new, or change an existing Administrator password. Note that if the Administrator Password is erased, the User Password will be cleared as well.

Password Check

Select Setup for the system to check for a password at Setup. Select Always for the system to check for a password at bootup or upon entering the BIOS Setup utility. The options are **Setup** and **Always**.

▶ Supermicro Security Erase Configuration

▶ Secure Boot

This section contains The options and menus for securing your boot mode and for key management.

Secure Boot

This option allows you specify when the Platform Key (PK) is enrolled. When enabled, the System Mode is user deployed, and the CSM function is disabled. The options include **Disabled** and **Enabled**.

Secure Boot Mode

Use this item to select the secure boot mode. The options are **Standard** and **Custom**.

CSM Support

Select **Enabled** to support the EFI Compatibility Support Module (CSM), which provides compatibility support for traditional legacy BIOS for system boot. The options are **Disabled** and **Enabled**.

▶ Key Management

This submenu allows the user to configure the following Key Management settings.

Vendor Keys

Provision Factory Defaults

Install factory default Secure Boot keys after the platform reset and while the System is in Setup mode. The default setting is **Disabled**.

▶ Restore Factory Keys

Select and press **Yes** to restore factory default secure boot keys and key variables. Also, it will reset the system to the User mode. Select **Yes** to install all default secure keys set by the manufacturer. The options are **Yes** and **No**.

▶ Reset To Setup Mode

This feature is to delete all Secure Boot databases from NVRAM. The options are **Yes** and **No**.

▶ Enroll Efi Image

This feature is to enroll SHA256 hash of the binary into the Authorized Signature Database (DB) and to allow the image to run in the secure boot mode.

▶ Export Secure Boot Variables

Use this feature to export NVRAM content of secure boot variables to files in a root folder on a file system device.

Secure Boot Variable / Size / Key Numbers / Key Source

▶ Platform Key (PK)

This feature allows the user to enter and configure a set of values to be used as platform firmware keys for the system. The sizes, keys numbers, and key sources of the platform keys will be indicated as well. Select Update to update the platform key. Select Yes to load a factory default PK or No to load from a file on an external media.

▶ Key Exchange Keys (KEK)

This feature allows the user to enter and configure a set of values to be used as Key-Exchange-Keys for the system. The sizes, keys numbers, and key sources of the Key-Exchange-Keys will be indicated as well. Select Update to update your "Key Exchange Keys". Select Append to append your "Key Exchange Keys".

▶ Authorized Signatures (db)

This feature allows the user to enter and configure a set of values to be used as Authorized Signatures for the system. These values also indicate the sizes, keys numbers, and the sources of the authorized signatures. Select Update to update your "Authorized Signatures". Select Append to append your "Authorized Signatures". The settings are Update, and Append.

▶ Forbidden Signatures (dbx)

This feature allows the user to enter and configure a set of values to be used as Forbidden Signatures for the system. These values also indicate sizes, keys numbers, and key sources of the forbidden signatures. Select Update to update your "Forbidden Signatures". Select Append to append your "Forbidden Signatures". The settings are Update, and Append.

▶ Authorized TimeStamps (dbt)

This feature allows the user to set and save the timestamps for the authorized signatures which will indicate the time when these signatures are entered into the system.

Select Update to update your "Authorized TimeStamps". Select Append to append your "Authorized TimeStamps". The settings are Update, and Append.

► **OsRecovery Signature (dbr)**

This item uploads and installs an OSRecovery Signature. Use this feature to export NVRAM content of secure boot variables to files in a root folder on a file system device.

The file formats accepted are:

- 1) Public Key Certificate
 - a. EFI Signature List
 - b. EFI CERT X509 (DER Encoded)
 - c. EFI CERT RSA2048 (bin)
 - d. EFI SERT SHA256 (bin)
- 2) Authenticated UEFI Variable
- 3) EFI PE/COFF Image (SHA256)

4.7 Boot Settings

Use this tab to configure Boot Settings:

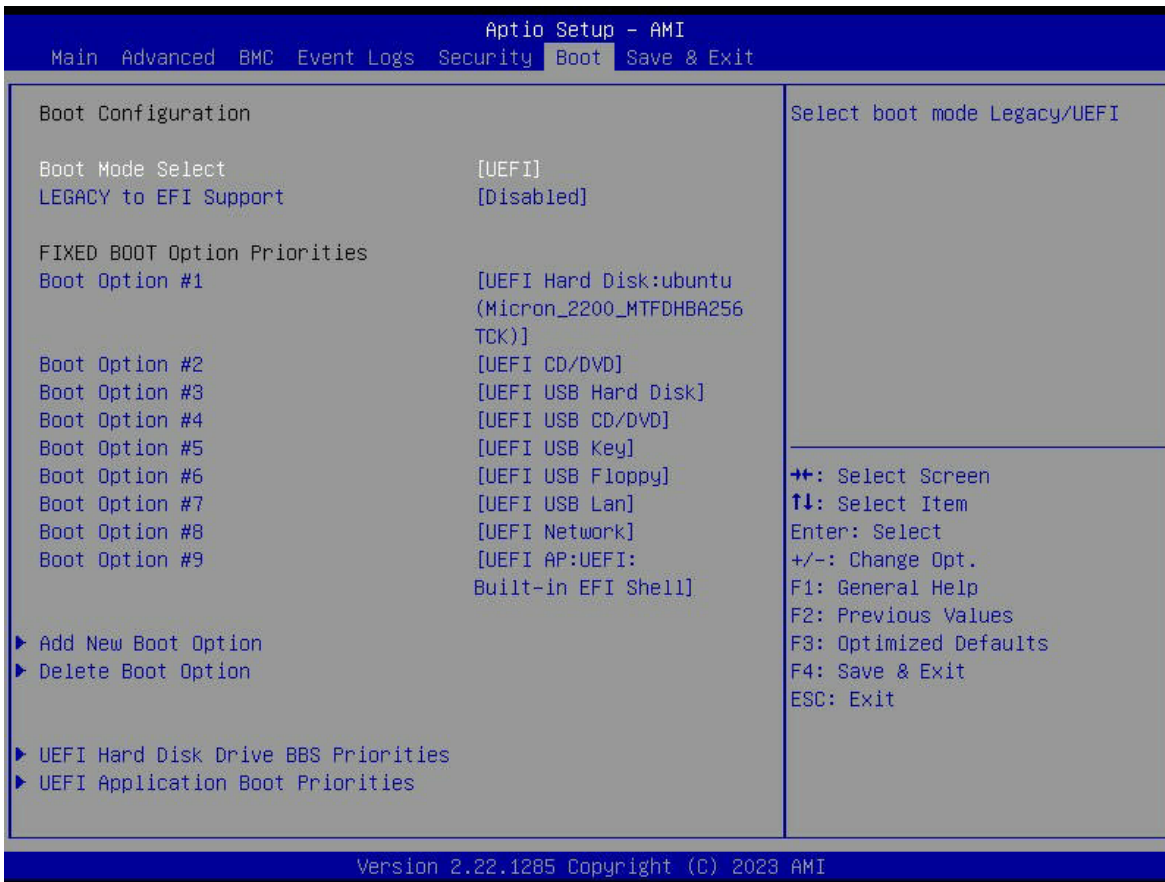

Boot Mode Select

Use this item to select the type of device that the system is going to boot from. The options are Legacy, **UEFI**, and DUAL. The default setting is **UEFI**.

Legacy to EFI Support

This option **Disables** or Enables the system to boot to an EFI OS after the boot failed from the legacy boot order.

FIXED BOOT ORDER Priorities Section

This option prioritizes the order of bootable devices that the system to boot from. Press <Enter> on each entry from top to bottom to select devices.

▶ Add New Boot Option

Add boot option

Use this setting to specify a name for a new boot option.

Path for boot option

Enter the path to the boot option in the format.

Boot option File Path

Create

Creates the newly formed boot option.

▶ Delete Boot Option

Use this feature to remove an EFI boot option from the boot order. The default is **Select one to Delete**.

▶ UEFI Hard Disk Key Drive BBS Priorities

Boot Option #1

Use this feature to set the system boot order.

▶ UEFI Application Boot Priorities

Boot Option #1

Use this feature to set the system boot order.

4.8 Save & Exit

Select the Save & Exit tab to enter the Save & Exit BIOS Setup screen.

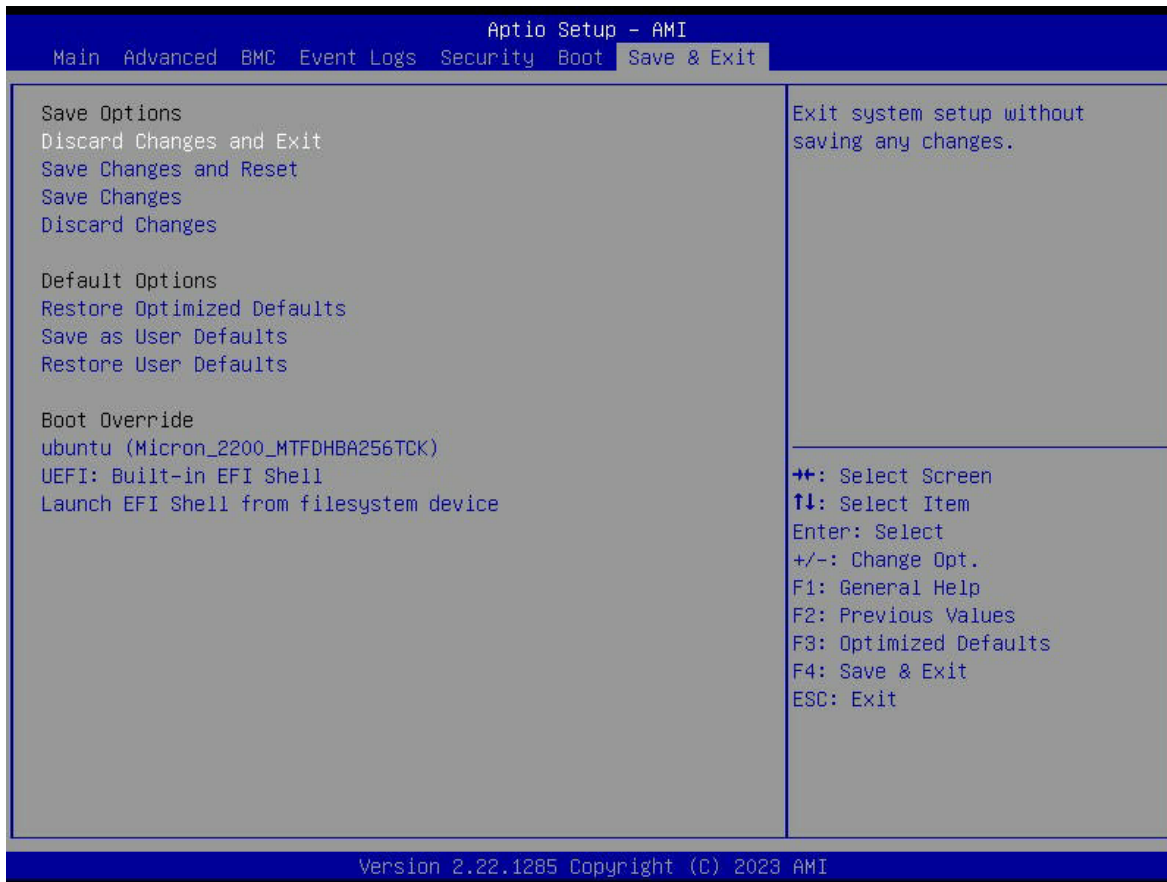

Save The options

Discard Changes and Exit

Select this option to quit the BIOS Setup without making any permanent changes to the system configuration, and reboot the computer. Select Discard Changes and Exit from the Exit menu and press <Enter>.

Save Changes and Reset

Select this option to reset the system after saving the changes.

Save Changes

After completing the system configuration changes, select this option to save the changes you have made. This will not reset (reboot) the system.

Discard Changes

Select this option and press <Enter> to discard all the changes and return to the AMI BIOS utility Program.

Default The options**Restore Optimized Defaults**

To set this feature, select Restore Defaults from the Save & Exit menu and press <Enter>. These are factory settings designed for maximum system stability, but not for maximum performance.

Save as User Defaults

To set this feature, select Save as User Defaults from the Exit menu and press <Enter>. This enables the user to save any changes to the BIOS setup for future use.

Restore User Defaults

To set this feature, select Restore User Defaults from the Exit menu and press <Enter>. Use this feature to retrieve user-defined settings that were saved previously.

Boot Override Section

Listed in this section are other boot The options for the system (i.e., UEFI: Built-in EFI Shell). Select an option and press <Enter>. Your system will boot to the selected boot option.

Appendix A

Software

After the hardware has been installed, you can install the Operating System (OS), configure RAID settings and install the drivers.

A.1 Microsoft Windows OS Installation

If you will be using RAID, you must configure RAID settings before installing the Windows OS and the RAID driver. Refer to the RAID Configuration User Guides posted on our website at www.supernmicro.com/support/manuals.

Installing the OS

1. Create a method to access the Microsoft Windows installation ISO file. That can be a USB flash or media drive.
2. Go to the Supermicro web page for your motherboard and click on "Download the Latest Drivers and Utilities", select the proper driver, and copy it to a USB flash drive.
3. Boot from a bootable device with Windows OS installation. You can see a bootable device list by pressing <F11> during the system startup.

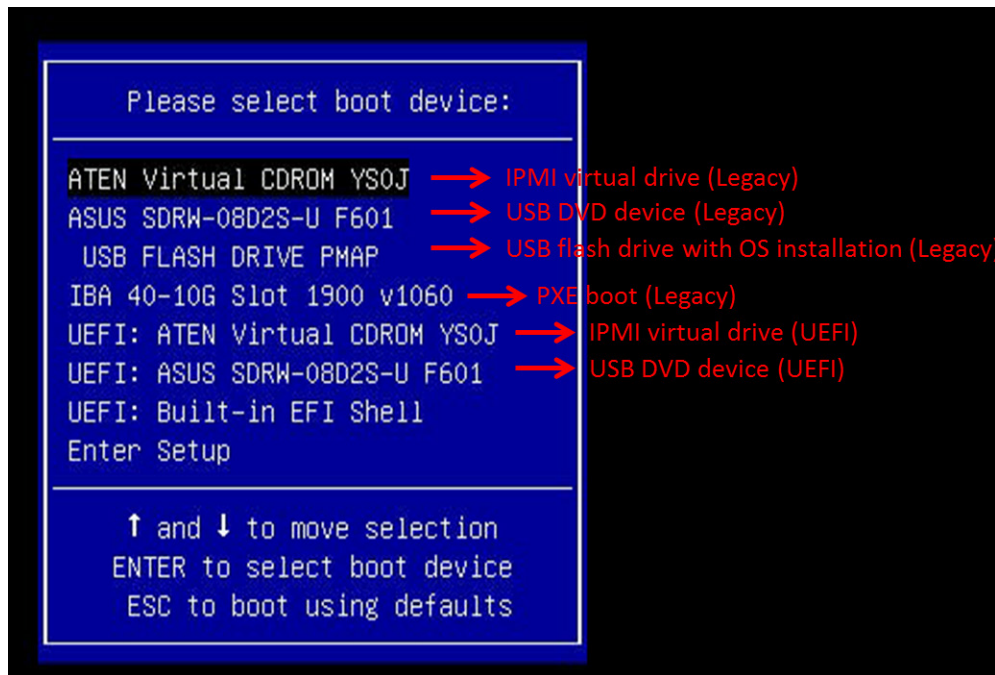

Figure A-1. Select Boot Device

4. During Windows Setup, continue to the dialog where you select the drives on which to install Windows. If the disk you want to use is not listed, click on “Load driver” link at the bottom left corner.

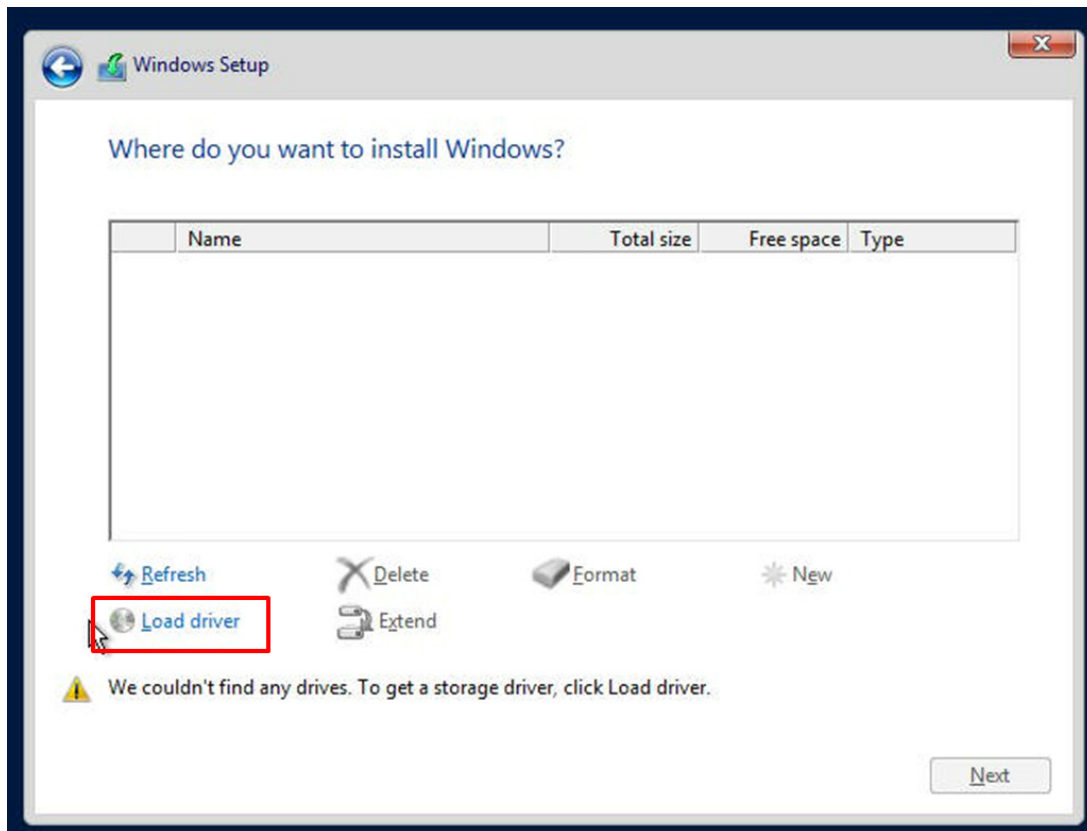

Figure A-2. Load Driver Link

To load the driver, browse the USB flash drive for the proper driver files.

- For RAID, choose the SATA/sSATA RAID driver indicated then choose the storage drive on which you want to install it.
 - For non-RAID, choose the SATA/sSATA AHCI driver indicated then choose the storage drive on which you want to install it.
5. Once all devices are specified, continue with the installation.
 6. After the Windows OS installation has completed, the system will automatically reboot multiple times.

A.2 Driver Installation

The Supermicro website contains drivers and utilities for your system at <https://www.supermicro.com/wdl/>. Some of these must be installed, such as the chipset driver. After accessing the website, go into the CDR_Images (in the parent directory of the above link) and locate the ISO file for your motherboard. Download this file to a USB flash or media drive. (You may also use a utility to extract the ISO file if preferred.)

Another option is to go to the Supermicro website at <http://www.supermicro.com/products/>. Find the product page for your motherboard, and "Download the Latest Drivers and Utilities". Insert the flash drive or disk and the screenshot shown below should appear.

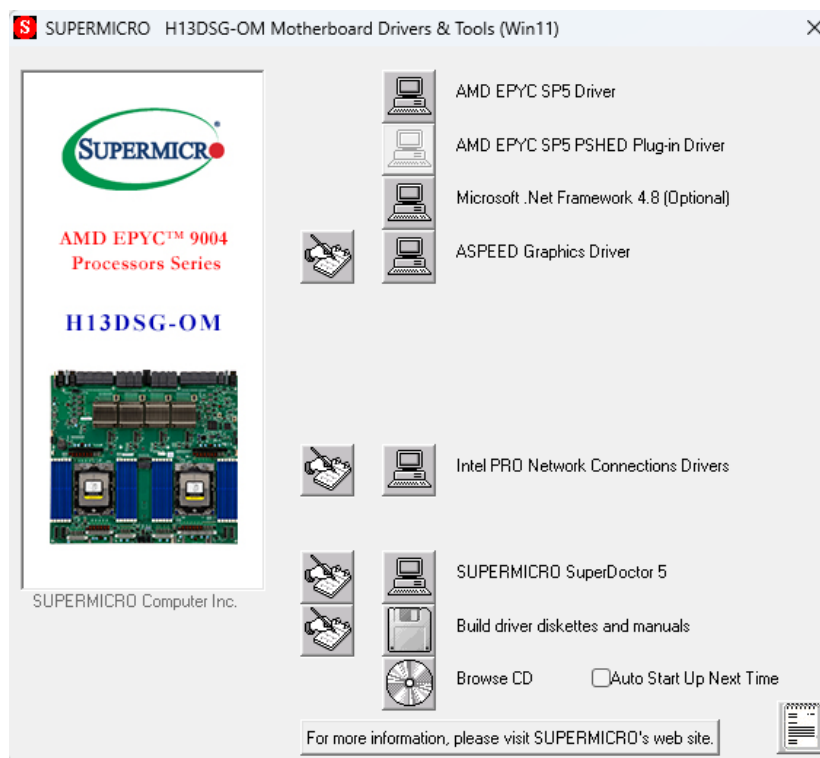

Figure A-3. Driver & Tool Installation Screen

Note: Click the icons showing a hand writing on paper to view the readme files for each item. Click the computer icons to the right of these items to install each item (from top to the bottom) one at a time. **After installing each item, you must re-boot the system before moving on to the next item on the list.** The bottom icon with a CD on it allows you to view the entire contents.

A.3 SuperDoctor® 5

The Supermicro SuperDoctor 5 is a program that functions in a command-line or web-based interface for Windows and Linux operating systems. The program monitors such system health information as CPU temperature, system voltages, system power consumption, fan speed, and provides alerts via email or Simple Network Management Protocol (SNMP).

SuperDoctor 5 comes in local and remote management versions and can be used with Nagios to maximize your system monitoring needs. With SuperDoctor 5 Management Server (SSM Server), you can remotely control power on/off and reset chassis intrusion for multiple systems with SuperDoctor 5 or IPMI. SuperDoctor 5 Management Server monitors HTTP, FTP, and SMTP services to optimize the efficiency of your operation.

[SuperDoctor® Manual and Resources](#)

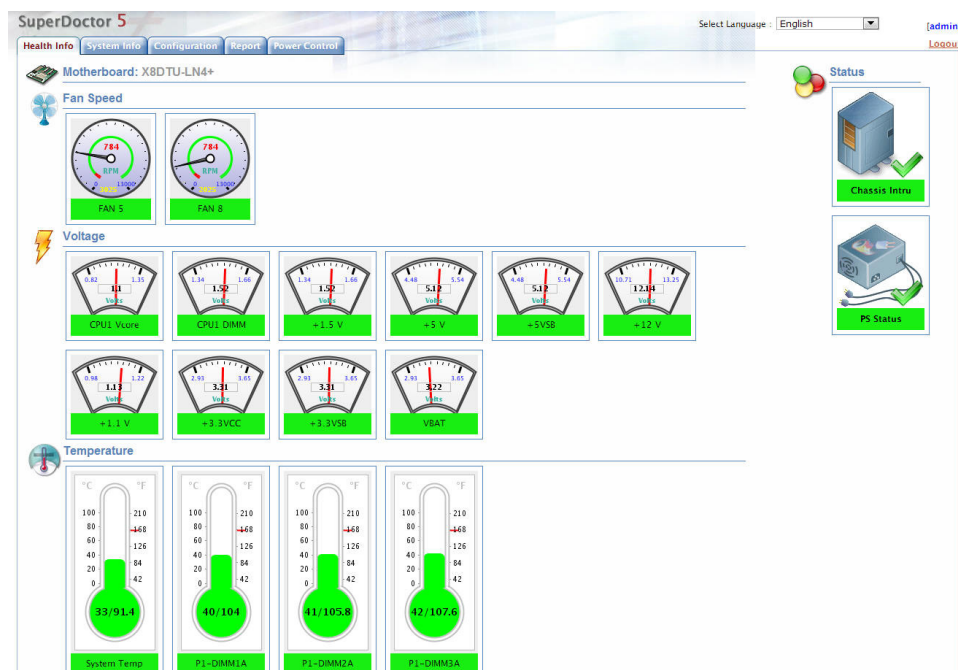

Figure A-4. SuperDoctor 5 Interface Display Screen (Health Information)

A.4 IPMI

The H13DSG-OM supports the Intelligent Platform Management Interface (IPMI). IPMI is used to provide remote access, monitoring and management. There are several BIOS settings that are related to IPMI.

Supermicro ships standard products with a unique password for the BMC ADMIN user. This password can be found on a label on the motherboard.

For general documentation and information on IPMI, visit our website at:

<http://www.supermicro.com/products/nfo/IPMI.cfm>.

Appendix B

Standardized Warning Statements

The following statements are industry standard warnings, provided to warn the user of situations which have the potential for bodily injury. Should you have questions or experience difficulty, contact Supermicro's Technical Support department for assistance. Only certified technicians should attempt to install or configure components.

Read this section in its entirety before installing or configuring components.

These warnings may also be found on our website at http://www.supermicro.com/about/policies/safety_information.cfm.

B.1 Battery Handling



Warning! There is the danger of explosion if the battery is replaced incorrectly. Replace the battery only with the same or equivalent type recommended by the manufacturer. Dispose of used batteries according to the manufacturer's instructions

電池の取り扱い

電池交換が正しく行われなかった場合、破裂の危険性があります。交換する電池はメーカーが推奨する型、または同等のものを使用下さい。使用済電池は製造元の指示に従って処分して下さい。

警告

電池更換不當會有爆炸危險。請只使用同類電池或制造商推薦的功能相當的電池更換原有電池。請按製造商的說明處理廢舊電池。

警告

電池更換不當會有爆炸危險。請使用製造商建議之相同或功能相當的電池更換原有電池。請按照製造商的說明指示處理廢棄舊電池。

Warnung

Bei Einsetzen einer falschen Batterie besteht Explosionsgefahr. Ersetzen Sie die Batterie nur durch den gleichen oder vom Hersteller empfohlenen Batterietyp. Entsorgen Sie die benutzten Batterien nach den Anweisungen des Herstellers.

Attention

Danger d'explosion si la pile n'est pas remplacée correctement. Ne la remplacer que par une pile de type semblable ou équivalent, recommandée par le fabricant. Jeter les piles usagées conformément aux instructions du fabricant.

¡Advertencia!

Existe peligro de explosión si la batería se reemplaza de manera incorrecta. Reemplazar la batería exclusivamente con el mismo tipo o el equivalente recomendado por el fabricante. Desechar las baterías gastadas según las instrucciones del fabricante.

אזהרה!

קיימת סכנת פיצוץ של הסוללה במידה והוחלפה בדרך לא תקינה. יש להחליף את הסוללה בסוג התואם מחברת יצרן מומלצת.

סילוק הסוללות המשומשות יש לבצע לפי הוראות היצרן.

هناك خطر من انفجار في حالة استبدال البطارية بطريقة غير صحيحة فعليك استبدال البطارية فقط بنفس النوع أو ما يعادلها كما أوصت به الشركة المصنعة تخلص من البطاريات المستعملة وفقا لتعليمات الشركة الصانعة

경고!

배터리가 올바르게 교체되지 않으면 폭발의 위험이 있습니다. 기존 배터리와 동일하거나 제조사에서 권장하는 동등한 종류의 배터리로만 교체해야 합니다. 제조사의 안내에 따라 사용된 배터리를 처리하여 주십시오.

Waarschuwing

Er is ontploffingsgevaar indien de batterij verkeerd vervangen wordt. Vervang de batterij slechts met hetzelfde of een equivalent type die door de fabrikant aanbevolen wordt. Gebruikte batterijen dienen overeenkomstig fabrieksvoorschriften afgevoerd te worden.

B.2 Product Disposal



Warning! Ultimate disposal of this product should be handled according to all national laws and regulations.

製品の廃棄

この製品を廃棄処分する場合、国の関係する全ての法律・条例に従い処理する必要があります。

警告

本产品的废弃处理应根据所有国家的法律和规章进行。

警告

本產品的廢棄處理應根據所有國家的法律和規章進行。

Warnung

Die Entsorgung dieses Produkts sollte gemäß allen Bestimmungen und Gesetzen des Landes erfolgen.

¡Advertencia!

Al deshacerse por completo de este producto debe seguir todas las leyes y reglamentos nacionales.

Attention

La mise au rebut ou le recyclage de ce produit sont généralement soumis à des lois et/ou directives de respect de l'environnement. Renseignez-vous auprès de l'organisme compétent.

סילוק המוצר

אזהרה!

סילוק סופי של מוצר זה חייב להיות בהתאם להנחיות וחוקי המדינה.

عند التخلص النهائي من هذا المنتج ينبغي التعامل معه وفقا لجميع القوانين واللوائح الوطنية

경고!

이 제품은 해당 국가의 관련 법규 및 규정에 따라 폐기되어야 합니다.

Waarschuwing

De uiteindelijke verwijdering van dit product dient te geschieden in overeenstemming met alle nationale wetten en reglementen.