



H13SVW-NT-OS2

USER'S MANUAL

Revision 1.0

The information in this User's Manual has been carefully reviewed and is believed to be accurate. The vendor assumes no responsibility for any inaccuracies that may be contained in this document, and makes no commitment to update or to keep current the information in this manual, or to notify any person or organization of the updates. **Please Note: For the most up-to-date version of this manual, please see our website at [www.supermicro.com](http://www.supermicro.com).**

Super Micro Computer, Inc. ("Supermicro") reserves the right to make changes to the product described in this manual at any time and without notice. This product, including software and documentation, is the property of Supermicro and/or its licensors, and is supplied only under a license. Any use or reproduction of this product is not allowed, except as expressly permitted by the terms of said license.

IN NO EVENT WILL Super Micro Computer, Inc. BE LIABLE FOR DIRECT, INDIRECT, SPECIAL, INCIDENTAL, SPECULATIVE OR CONSEQUENTIAL DAMAGES ARISING FROM THE USE OR INABILITY TO USE THIS PRODUCT OR DOCUMENTATION, EVEN IF ADVISED OF THE POSSIBILITY OF SUCH DAMAGES. IN PARTICULAR, SUPER MICRO COMPUTER, INC. SHALL NOT HAVE LIABILITY FOR ANY HARDWARE, SOFTWARE, OR DATA STORED OR USED WITH THE PRODUCT, INCLUDING THE COSTS OF REPAIRING, REPLACING, INTEGRATING, INSTALLING OR RECOVERING SUCH HARDWARE, SOFTWARE, OR DATA.

Any disputes arising between manufacturer and customer shall be governed by the laws of Santa Clara County in the State of California, USA. The State of California, County of Santa Clara shall be the exclusive venue for the resolution of any such disputes. Supermicro's total liability for all claims will not exceed the price paid for the hardware product.

FCC Statement: This equipment has been tested and found to comply with the limits for a Class A or Class B digital device pursuant to Part 15 of the FCC Rules. These limits are designed to provide reasonable protection against harmful interference when the equipment is operated in industrial environment for Class A device or in residential environment for Class B device. This equipment generates, uses, and can radiate radio frequency energy and, if not installed and used in accordance with the manufacturer's instruction manual, may cause harmful interference with radio communications. Operation of this equipment in a residential area is likely to cause harmful interference, in which case you will be required to correct the interference at your own expense.

California Best Management Practices Regulations for Perchlorate Materials: This Perchlorate warning applies only to products containing CR (Manganese Dioxide) Lithium coin cells. "Perchlorate Material-special handling may apply. See [www.dtsc.ca.gov/hazardouswaste/perchlorate](http://www.dtsc.ca.gov/hazardouswaste/perchlorate)".

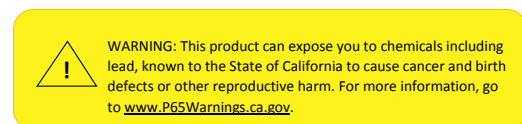

The products sold by Supermicro are not intended for and will not be used in life support systems, medical equipment, nuclear facilities or systems, aircraft, aircraft devices, aircraft/emergency communication devices or other critical systems whose failure to perform be reasonably expected to result in significant injury or loss of life or catastrophic property damage. Accordingly, Supermicro disclaims any and all liability, and should buyer use or sell such products for use in such ultra-hazardous applications, it does so entirely at its own risk. Furthermore, buyer agrees to fully indemnify, defend and hold Supermicro harmless for and against any and all claims, demands, actions, litigation, and proceedings of any kind arising out of or related to such ultra-hazardous use or sale.

Manual Revision 1.0

Release Date: June 04, 2025

Unless you request and receive written permission from Super Micro Computer, Inc., you may not copy any part of this document. Information in this document is subject to change without notice. Other products and companies referred to herein are trademarks or registered trademarks of their respective companies or mark holders.

Copyright © 2025 by Super Micro Computer, Inc.  
All rights reserved.

**Printed in the United States of America**

# Preface

## About This Manual

This manual is written for system integrators, IT technicians and knowledgeable end users. It provides information for the installation and use of the H13SVW-NT-OS2 motherboard.

## About This Motherboard

Built upon the functionality and capability of the AMD EPYC™Series\* processor, the H13SVW-NT-OS2 motherboard provides a high performance, expandable solution while consuming little power. Please note that this motherboard is intended to be installed and serviced by professional technicians only. For processor/memory updates, please refer to our website at <http://www.supermicro.com/products/>.

## Conventions Used in the Manual

Special attention should be given to the following symbols for proper installation and to prevent damage done to the components or injury to yourself:



**Warning!** Indicates important information given to prevent equipment/property damage or personal injury.



**Warning!** Indicates high voltage may be encountered when performing a procedure.

## Contacting Supermicro

### Headquarters

Address: Super Micro Computer, Inc.  
980 Rock Ave.  
San Jose, CA 95131 U.S.A.

Tel: +1 (408) 503-8000

Fax: +1 (408) 503-8008

Email: marketing@supermicro.com (General Information)  
Sales-USA@supermicro.com (Sales Inquiries)  
Government\_Sales-USA@supermicro.com (Gov. Sales Inquiries)  
support@supermicro.com (Technical Support)  
RMA@supermicro.com (RMA Support)  
Webmaster@supermicro.com (Webmaster)

Website: [www.supermicro.com](http://www.supermicro.com)

### Europe

Address: Super Micro Computer B.V.  
Het Sterrenbeeld 28, 5215 ML  
's-Hertogenbosch, The Netherlands

Tel: +31 (0) 73-6400390

Fax: +31 (0) 73-6416525

Email: Sales\_Europe@supermicro.com (Sales Inquiries)  
Support\_Europe@supermicro.com (Technical Support)  
RMA\_Europe@supermicro.com (RMA Support)

Website: [www.supermicro.nl](http://www.supermicro.nl)

### Asia-Pacific

Address: Super Micro Computer, Inc.  
3F, No. 150, Jian 1st Rd.  
Zhonghe Dist., New Taipei City 235  
Taiwan (R.O.C)

Tel: +886-(2) 8226-3990

Fax: +886-(2) 8226-3992

Email: Sales-Asia@supermicro.com.tw (Sales Inquiries)  
Support@supermicro.com.tw (Technical Support)  
RMA@supermicro.com.tw (RMA Support)

Website: [www.supermicro.com.tw](http://www.supermicro.com.tw)

# Table of Contents

Contacting Supermicro.....	4
<b>Chapter 1 Introduction</b>	
1.1 Checklist.....	8
1.2 Quick Reference.....	10
Quick Reference Table.....	11
Motherboard Features.....	12
1.3 Processor and Chipset Overview.....	15
1.4 System Health Monitoring.....	15
Onboard Voltage Monitors.....	15
Fan Status Monitor with Firmware Control.....	15
Environmental Temperature Control.....	16
System Resource Alert.....	16
1.5 ACPI Features.....	16
1.6 Power Supply.....	16
1.7 Super I/O.....	17
<b>Chapter 2 Installation</b>	
2.1 Static-Sensitive Devices.....	18
Precautions.....	18
Unpacking.....	18
2.2 Motherboard Installation.....	19
Location of Mounting Holes.....	19
Installing the Motherboard.....	21
2.3 Processor and Heatsink Installation.....	22
2.4 Memory Support and Installation.....	29
Memory Support.....	29
DIMM Module Population.....	30
DIMM Installation.....	31
DIMM Removal.....	31
2.5 Rear I/O Ports.....	32
2.6 Front Control Panel.....	34
Front Control Panel Pin Definitions.....	35

2.7 Headers and Connectors .....	38
Power Connections .....	38
2.8 Jumper Settings .....	42
How Jumpers Work.....	42
2.9 LED Indicators.....	44

**Chapter 3 Troubleshooting**

3.1 Troubleshooting Procedures .....	46
Before Power On .....	46
No Power .....	46
No Video .....	47
System Boot Failure.....	47
Memory Errors .....	47
When the System Keeps Losing its Setup Configuration.....	47
If the System Becomes Unstable.....	48
3.2 Technical Support Procedures .....	49
3.3 Frequently Asked Questions .....	49
3.4 Returning Merchandise for Service.....	51
3.5 Battery Removal and Installation .....	51
Battery Removal.....	51
Proper Battery Disposal .....	51
Battery Installation.....	52

**Chapter 4 UEFI BIOS**

4.1 Introduction.....	53
Starting the Setup Utility .....	53
4.2 Main Setup .....	54
4.3 Advanced.....	56
4.4 BMC.....	75
4.5 Event Logs .....	79
4.6 Security.....	81
4.7 Boot .....	86
4.8 Save & Exit.....	88

---

---

## ***Appendix A Software***

A.1 Microsoft Windows OS Installation.....	90
A.2 Driver Installation.....	92
A.3 SuperDoctor® 5.....	93
A.4 IPMI .....	93

## ***Appendix B Standardized Warning Statements***

B.1 Battery Handling.....	94
B.2 Product Disposal .....	96

## ***Appendix C UEFI BIOS Recovery***

C.1 Overview.....	97
C.2 Recovering the UEFI BIOS Image.....	97
C.3 Recovering the BIOS Block with a USB Device .....	97

# Chapter 1

## Introduction

Congratulations on purchasing your computer motherboard from an industry leader. Supermicro motherboards are designed to provide you with the highest standards in quality and performance.

In addition to the motherboard, several important parts that are included with the system are listed below. If anything listed is damaged or missing, please contact your retailer.

### 1.1 Checklist

Main Parts List		
Description	Part Number	Quantity
Supermicro motherboard H13SVW-NT-OS2	MBD-H13SVW-NT-OS2	1
MCIO to 8x SATA Cable	CBL-MCIO-12700T4S2-85	1

### Important Links

For your system to work properly, please follow the links below to download all necessary drivers/utilities and the user's manual for your server.

- Supermicro product manuals: <https://www.supermicro.com/support/manuals/>
- Product drivers and utilities: <https://www.supermicro.com/wdl/>
- Product safety info: [https://www.supermicro.com/about/policies/safety\\_information.cfm](https://www.supermicro.com/about/policies/safety_information.cfm)
- If you have any questions, please contact our support team at: [support@supermicro.com](mailto:support@supermicro.com)

This manual may be periodically updated without notice. Please check the Supermicro website for possible updates to the manual revision level.

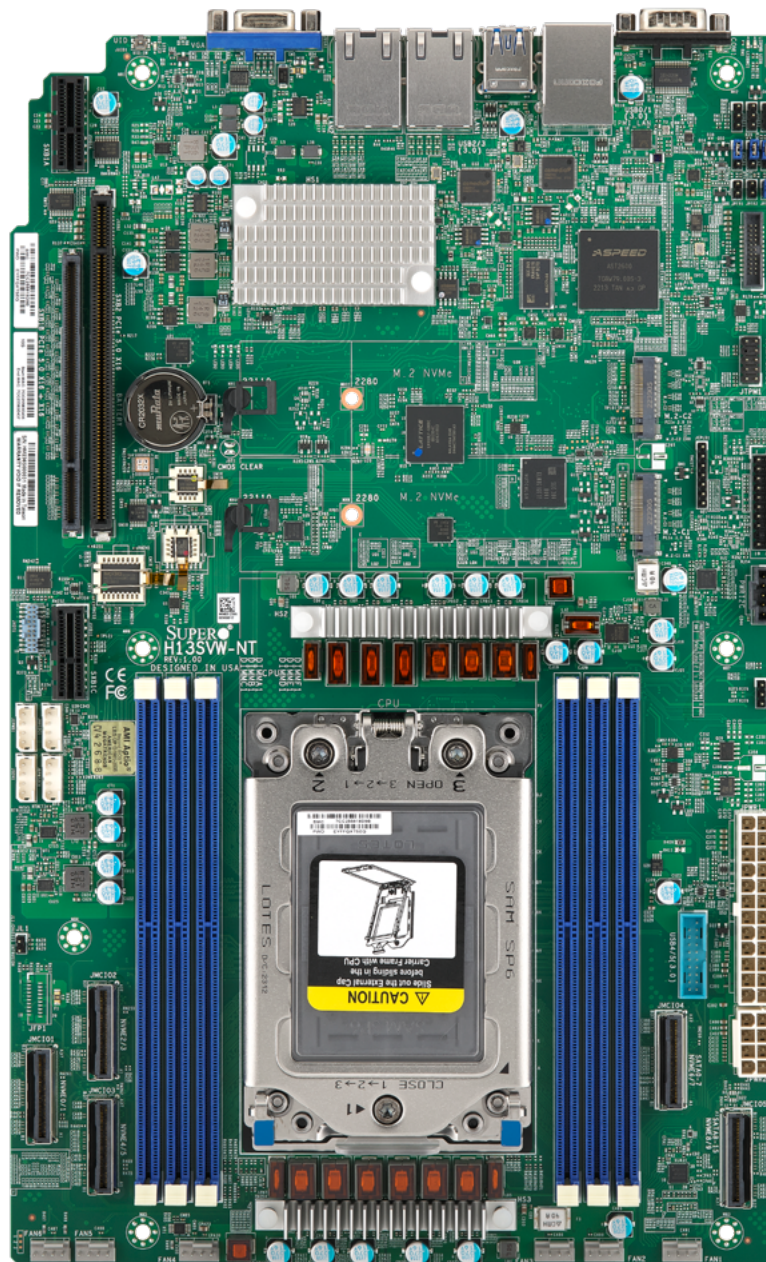

**Figure 1-1. Motherboard Image**

**Note:** All graphics shown in this manual were based upon the latest PCB revision available at the time of publication of the manual. The motherboard you received may or may not look exactly the same as the graphics shown in this manual.

## 1.2 Quick Reference

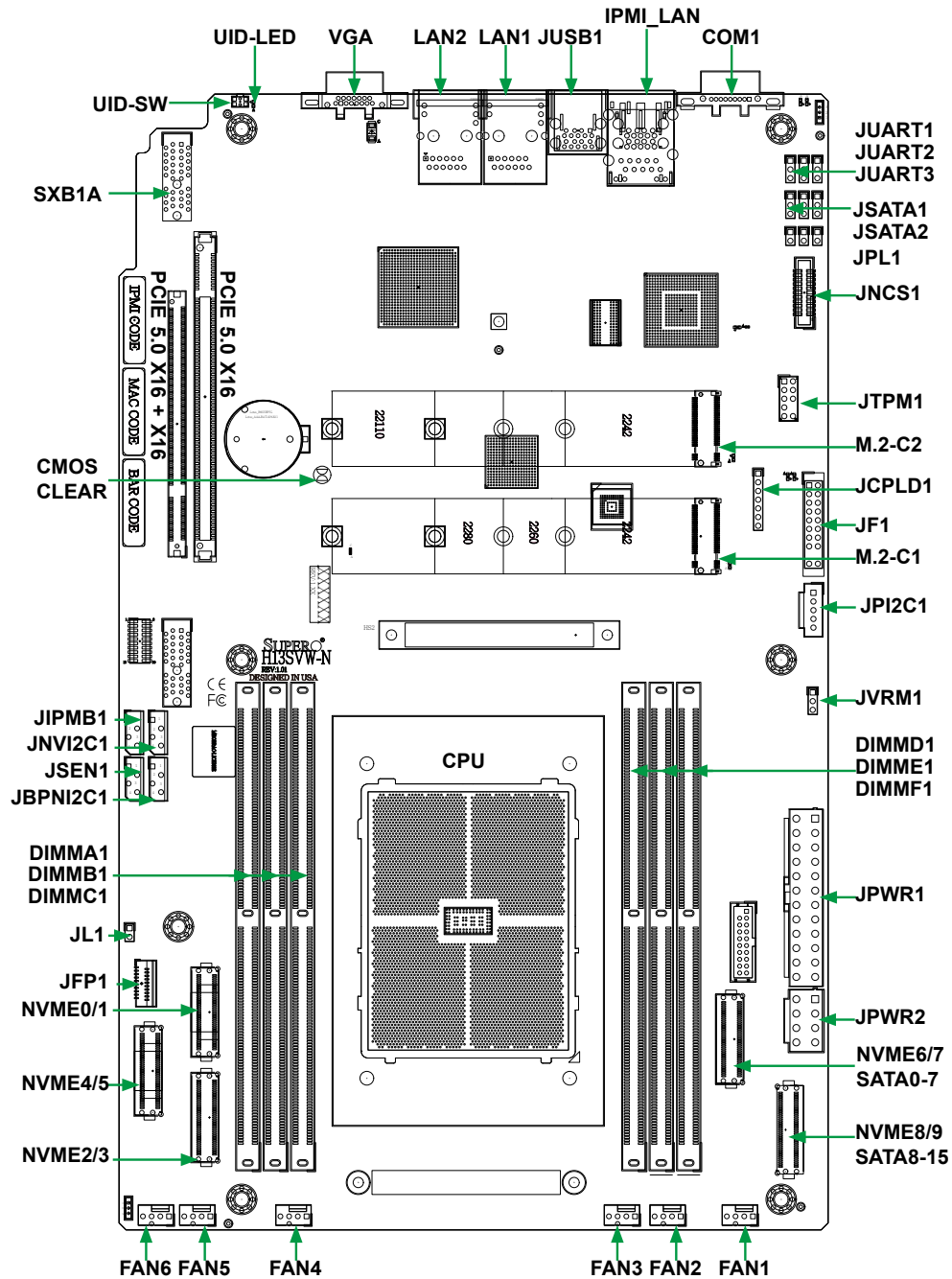

Figure 1-2. Motherboard Layout

### Notes:

- See Chapter 2 for detailed information on jumpers, I/O ports, and JF1 front panel connections.
- Jumpers/LED indicators not indicated are used for testing only.
- Use only the correct type of onboard CMOS battery as specified by the manufacturer. Do not install the onboard battery upside down to avoid possible explosion.

## Quick Reference Table

Jumper	Description	Default Setting
JBT1	Clear CMOS	Open (Normal)
JPL1	LAN enable/disable	Pins 1-2 (Enabled)
JSATA1	Hybrid MCIO select for JMCIO4	Pins 1-2 (Auto)
JSATA2	Hybrid MCIO select for JMCIO5	Pins 1-2 (Auto)
UID SW	Unit ID switch (push-button toggle switch ON/OFF)	Off

LED	Description	Status
LEDBMC	BMC Heartbeat	Blinking: BMC Normal/Working
LED8	Power LED	On: Power On
LED9	UID LED	Blue: UID Activated

Connector	Description
Battery (BT1)	Onboard CMOS battery
COM 1	Rear panel COM port 1
FAN 1-6	System cooling fan headers
JF1	Front control panel
JIPMB1	4-pin external BMC I2C header (for an IPMI card)
JL1	Chassis intrusion header
JPI2C1	PWR supply (I2C) System Management Bus
JPWR1	24-pin ATX power supply connector
JPWR2	12V 8-pin ATX CPU power connector
JSXB1A, JSXB1B, JSXB1C, JSXB2	Slots for Supermicro riser cards
JTPM1	Trusted Platform Module (TPM)/Port 80 connector
LAN1, LAN2	Back panel LAN1, LAN2 connectors
M.2-C1, M.2-C2	M.2 slots
NVMe0-5	NVMe slots 0-5
USB 0/1 (3.0)	Back panel USB 3.0 ports (USB 0/1)
USB 2/3 (3.0)	Back panel USB 3.0 ports (USB 2/3)
USB 4/5 (3.0)	Internal USB 3.0 header (USB 4/5)
VGA	Back panel VGA port

**Note:** Jumpers, connectors, switches, and LED indicators that are not described in the preceding tables are for manufacturing testing purposes only, and are not covered in this manual.

## Motherboard Features

### Features

#### CPU

- A Single AMD EPYC™ 8004 Series processor, housed in an SP6 socket

#### Memory

- Up to 576 GB of Registered ECC DDR5 up to 4800 MT/s SDRAM memory in six slots

#### DIMM Size

- Up to 96 GB at 12 V

#### Chipset

- System on Chip

#### Expansion Slots

- One PCIe 5.0 (x32) Left Riser Slot
- One PCIe 5.0 (x16) Right Riser Slot
- Two PCIe 5.0 (x4) NVMe M.2
- Five PCIe 5.0 x8 Connectors
- M.2 Form Factor: 2280, 22110
- M.2 Key: M-Key

#### Network

- Two 10 GbE LAN ports via Broadcom BCM57416
- One Realtek RTL8211F PHY (dedicated IPMI)

#### Graphics

- ASPEED AST2600 BMC chip with one VGA port

#### I/O Devices

- One COM port
- One TPM 2.0 header
- Six USB 3.0 ports (four rear, two via header)

#### Peripheral Devices

- Three native NVMe Ports (MCIO x8); two internal NVMe or sixteen SATA hybrid use ports (MCIO x8)

**Note:** The table above is continued on the next page.

---

---

## Features

### BIOS

- 256 Mb SPI AMI BIOS®
- ACPI 6.5; SMBIOS 3.6.0, Plug-and-Play (PnP), BIOS rescue hot-key, RTC (Real Time Clock) wake up, Riser Card Auto-Detection Support

### Power Management

- ACPI power management
- Power button override mechanism
- Power-on mode for AC power recovery

### System Health Monitoring

- Onboard voltage monitoring for +3.3 V, +3.3 V Standby, +12 V, +5 V, +5 V Standby
- Onboard monitoring for CPU, system, and memory temperature
- CPU switching voltage regulator
- CPU Thermal Trip support

### Fan Control

- Single cooling zone
- Low-noise fan speed control
- Pulse Width Modulation (PWM) fan control

### System Management

- Trusted Platform Module (TPM) support
- System resource alert via SuperDoctor® 5
- SuperDoctor® 5, Watch Dog
- Non-Maskable Interrupt (NMI)
- SUM-InBand, SUM-OOB, IPMICFG, IPMIView, SMCIPMITOOL

### LED Indicators

- Power State Indicator
- CPU/Overheating
- Fan Failure
- LAN activity
- UID / Remote UID

### Dimensions

- 8.15" (L) x 13.05" (W), 20.32 cm (L) x 33.02 cm (W)

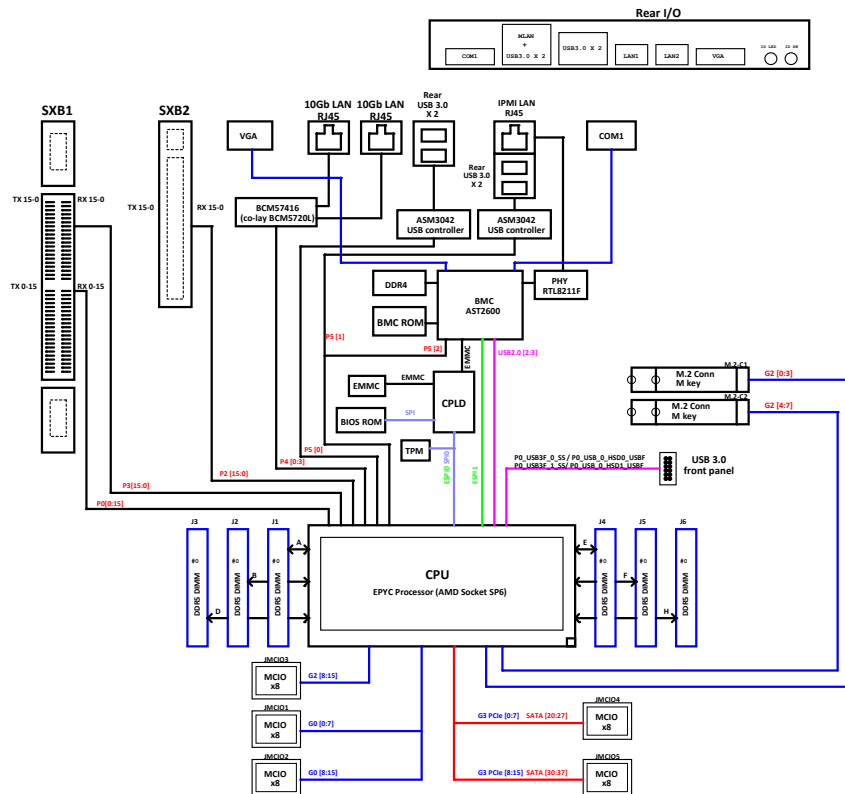

**Figure 1-3. System Block Diagram**

**Note:** This is a general block diagram and may not exactly represent the features on your motherboard. See the previous pages for the actual specifications of your motherboard.

## 1.3 Processor and Chipset Overview

The H13SVW-NT-OS2 motherboard offers maximum I/O expendability, energy efficiency, and data reliability. It is optimized for high-performance computing, NVMe storage solutions, and ideal for High Density Data Center applications.

The H13SVW-NT-OS2 supports the new 5-nm microarchitecture process technology, which significantly increases system performance for a multitude of server applications.

The AMD EPYC™ 8004 Series supports the following features:

- ACPI Power Management Logic Support Rev. 6.5
- Adaptive Thermal Management/Monitoring
- PCIe 5.0 w/transfer rates of up to 32 Gb/s
- SATA 3.0 w/transfer rates of up to 6 Gb/s
- System Management Bus (SMBus) Specification Version 2.0

## 1.4 System Health Monitoring

The H13SVW-NT-OS2 motherboard has an onboard Baseboard Management Controller (BMC) chip that supports system health monitoring.

### Onboard Voltage Monitors

The onboard voltage monitor will continuously scan crucial voltage levels. Once a voltage becomes unstable, it will give a warning or send an error message to the screen. Users can adjust the voltage thresholds to define the sensitivity of the voltage monitor. Real time readings of these voltage levels are all displayed in BMC.

### Fan Status Monitor with Firmware Control

Users can check the RPM status of the cooling fans through the IPMI Web interface. The chassis fans are controlled by Thermal Management.

## Environmental Temperature Control

The thermal control sensor monitors the CPU temperature in real time and will turn on the thermal control fan whenever the CPU temperature exceeds a user-defined threshold. The overheat circuitry runs independently from the CPU. Once the thermal sensor detects that the CPU temperature is too high, it will automatically turn on the thermal fans to prevent the CPU from overheating. The onboard chassis thermal circuitry can monitor the overall system temperature and alert the user when the chassis temperature is too high.

**Note:** To avoid possible system overheating, please be sure to provide adequate airflow to your system.

## System Resource Alert

This feature is available when used with SuperDoctor 5®. SuperDoctor 5 is used to notify the user of certain system events. For example, you can configure SuperDoctor 5 to provide you with warnings when the system temperature, CPU temperatures, voltages and fan speeds go beyond a predefined range.

## 1.5 ACPI Features

ACPI stands for Advanced Configuration and Power Interface. The ACPI specification defines a flexible and abstract hardware interface that provides a standard way to integrate power management features throughout a computer system including its hardware, operating system and application software. This enables the system to automatically turn on and off peripherals such as network cards, storage drives and printers.

In addition to enabling operating system-directed power management, ACPI also provides a generic system event mechanism for Plug and Play and an operating system-independent interface for configuration control. ACPI leverages the Plug and Play BIOS data structures while providing a processor architecture-independent implementation that is compatible with Windows 2019 and 2022 operating systems.

## 1.6 Power Supply

As with all computer products, a stable power source is necessary for proper and reliable operation. It is even more important for processors that have high CPU clock rates. In areas where noisy power transmission is present, you may choose to install a line filter to shield the computer from noise. It is recommended that you also install a power surge protector to help avoid problems caused by power surges.

## 1.7 Super I/O

The ASpeed AST2600 Super I/O provides one high-speed, 16550 compatible Universal Asynchronous Receiver/Transmitter (UART), which support serial infrared communications. This UART includes a send/receive FIFO, a programmable baud rate generator, complete modem control capability and a processor interrupt system. This UART provides legacy speed with baud rate of up to 115.2 Kbps as well as an advanced speed with baud rates of 250 K, 500 K, or 1 Mb/s, which support higher speed modems.

The Super I/O provides functions that comply with ACPI (Advanced Configuration and Power Interface), which includes support of legacy and ACPI power management through the System Management Interrupt (SMI) or System Control Interrupt (SCI). It also features auto power management to reduce power consumption.

# Chapter 2

## Installation

### 2.1 Static-Sensitive Devices

Electrostatic Discharge (ESD) can damage electronic components. To prevent damage to your motherboard, it is important to handle it very carefully. The following measures are generally sufficient to protect your equipment from ESD.

#### Precautions

- Use a grounded wrist strap designed to prevent static discharge.
- Touch a grounded metal object before removing the board from the antistatic bag.
- Handle the board by its edges only; do not touch its components, peripheral chips, memory modules or gold contacts.
- When handling chips or modules, avoid touching their pins.
- Put the motherboard and peripherals back into their antistatic bags when not in use.
- For grounding purposes, make sure that your chassis provides excellent conductivity between the power supply, the case, the mounting fasteners and the motherboard.
- Use only the correct type of CMOS onboard battery as specified by the manufacturer. Do not install the CMOS battery upside down, which may result in a possible explosion.

#### Unpacking

The motherboard is shipped in antistatic packaging to avoid static damage. When unpacking the motherboard, make sure that the person handling it is static protected.

## 2.2 Motherboard Installation

All motherboards have standard mounting holes to fit different types of chassis. Make sure that the locations of all the mounting holes for both the motherboard and the chassis match. Although a chassis may have both plastic and metal mounting fasteners, metal ones are highly recommended because they ground the motherboard to the chassis. Make sure that the metal standoffs click in or are screwed in tightly.

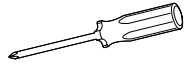

Phillips Screwdriver (1)



Phillips Screws



Standoffs (Only if needed)

### Tools Needed

### Location of Mounting Holes

#### Notes:

1. To avoid damaging the motherboard and its components, please do not use a force greater than 8 lb/inch on each mounting screw during motherboard installation.
2. Some components are very close to the mounting holes. Please take precautionary measures to avoid damaging these components when installing the motherboard to the chassis.

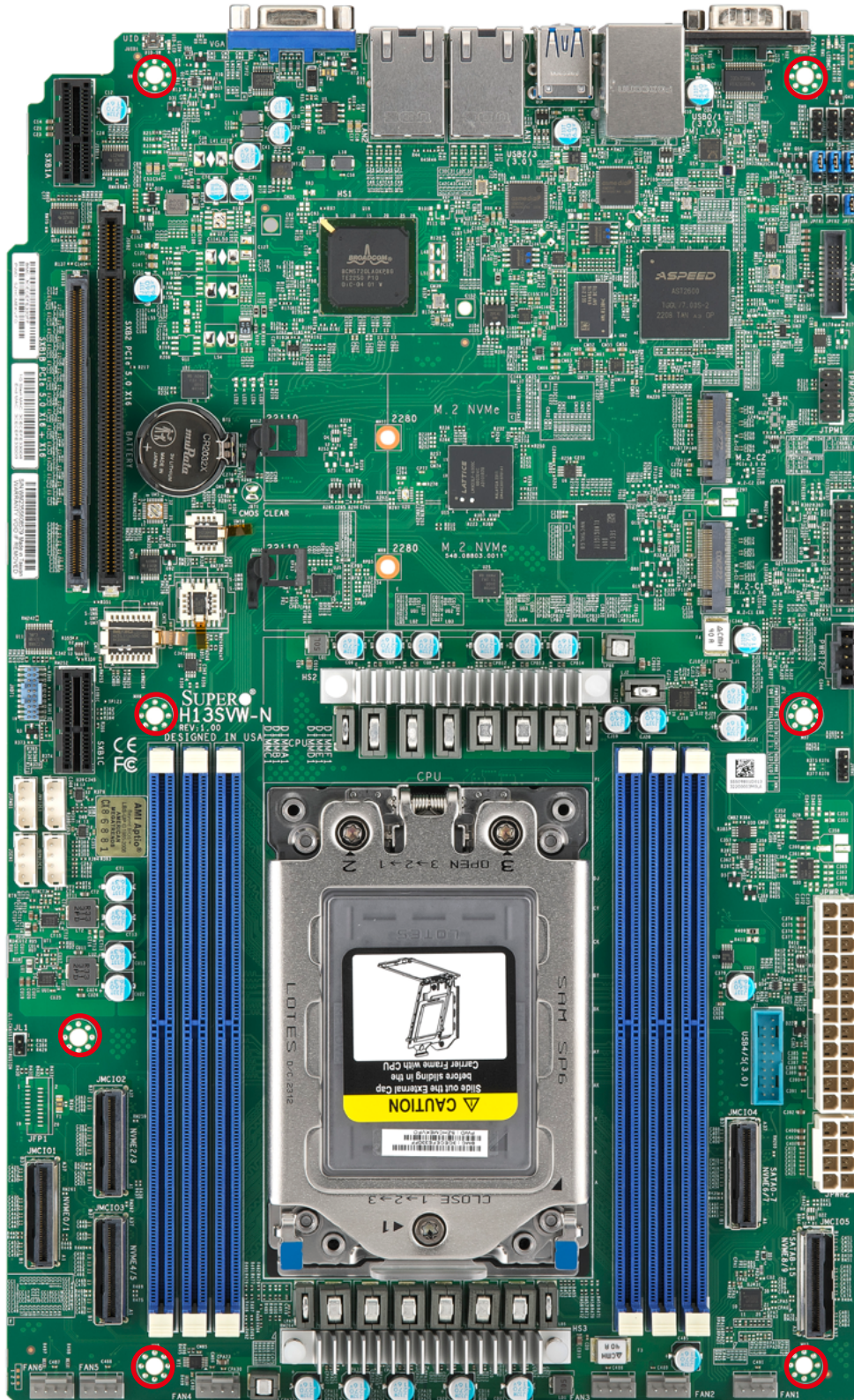
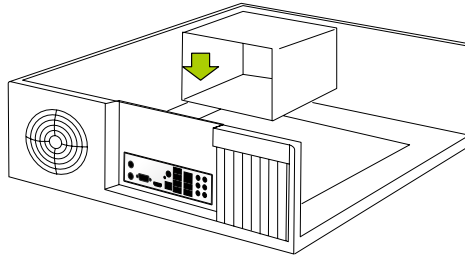

Figure 2-1. Motherboard Mounting Holes (H13SVW-NT-OS2)

## Installing the Motherboard

1. Install the I/O shield into the back of the chassis.



2. Locate the mounting holes on the motherboard. See the previous page for the locations.

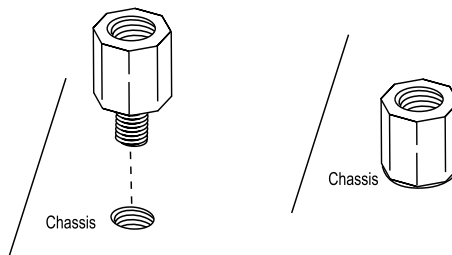

3. Locate the matching mounting holes on the chassis. Align the mounting holes on the motherboard with the mounting holes on the chassis.

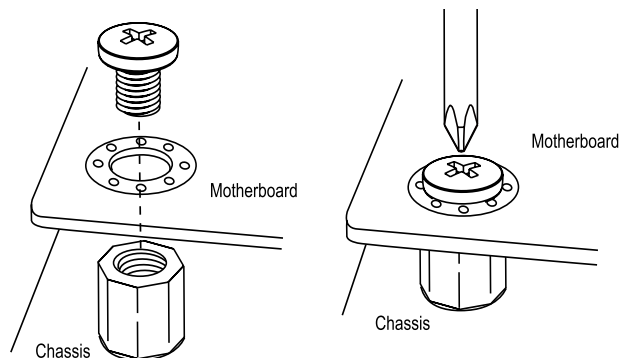

4. Install standoffs in the chassis as needed.
5. Install the motherboard into the chassis carefully to avoid damaging other motherboard components.
6. Using the Phillips screwdriver, insert a Phillips head #6 screw into a mounting hole on the motherboard and its matching mounting hole on the chassis.
7. Repeat the above step to insert #6 screws in the rest of mounting holes.
8. Make sure that the motherboard is securely placed in the chassis.

**Note:** Images displayed are for illustration purposes only. Your chassis or components might look different from those shown in this manual.

## 2.3 Processor and Heatsink Installation

**Important:** When handling the processor package, avoid placing direct pressure on the label area of the fan.

**Important:**

- For the Processor/Heatsink installation you need to use a T20 screwdriver when opening/closing the CPU socket.
- Always connect the power cord last, and always remove it before adding, removing or changing any hardware components. Make sure that you install the processor into the CPU socket before you install the CPU heatsink.
- If you buy a CPU separately, make sure that you use an AMD-certified heatsink only. Make sure to install the motherboard into the chassis before you install the CPU heatsink.
- When receiving a motherboard without a processor pre-installed, make sure that the plastic CPU socket cap is in place and none of the socket pins are bent; otherwise, contact your retailer immediately.
- When installing the processor and heatsink, ensure a torque driver set to the correct force is used for each screw.
- Refer to the Supermicro website for updates on CPU support.

### *Installing the Processor and Heatsink*

1. Unscrew the screws holding down Force Frame in the sequence of 3-2-1. The screws are numbered on the force frame next to each screw hole.

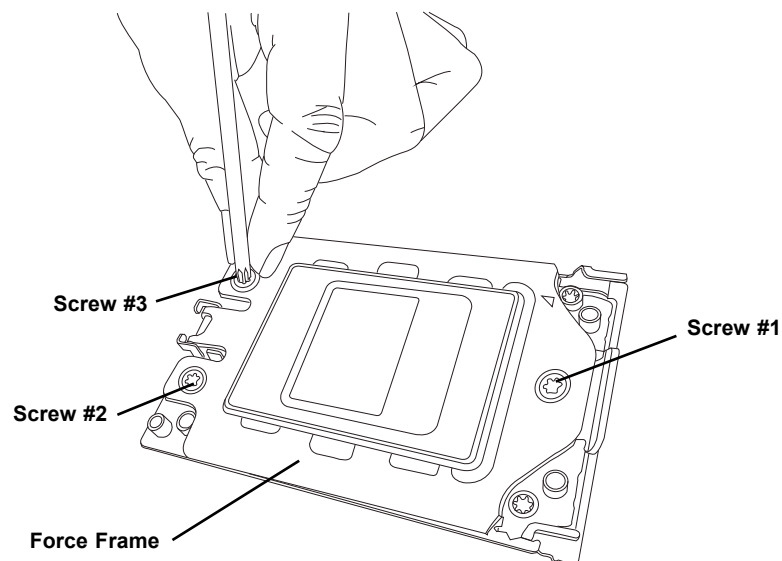

2. The spring-loaded force frame will raise up after the last screw securing it (#1) is removed. Gently allow it to lift up to its stopping position.

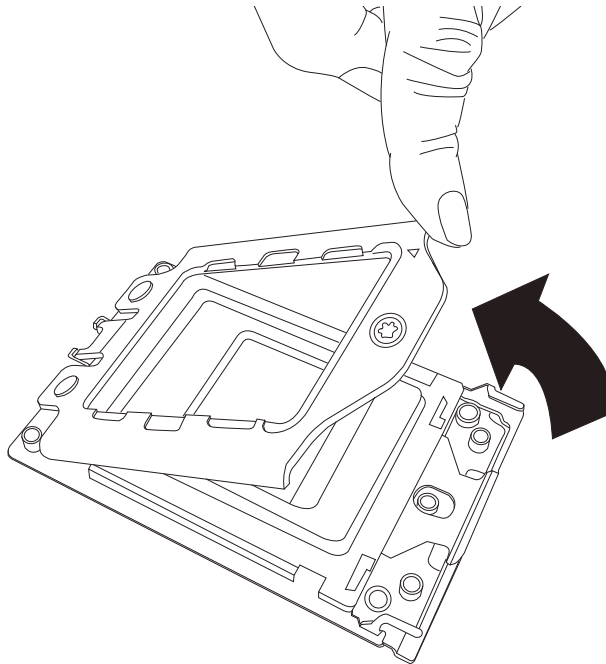

3. Lift the rail frame up by gripping the lift tabs near the front end of the rail frame. While keeping a secure grip of the rail frame, lift it to a position so you can do the next step of removing the external cap.

**Note:** The rail frame is spring loaded, so keep a secure grip on it as you lift it so it does not snap up.

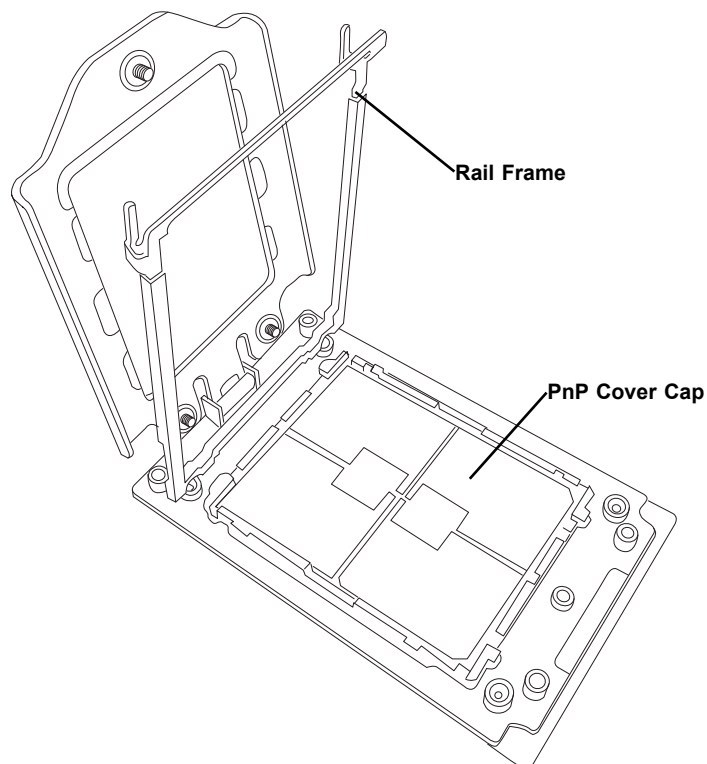

4. Remove the external cap from the Rail Frame by pulling it upwards through the rail guides on the rail frame.

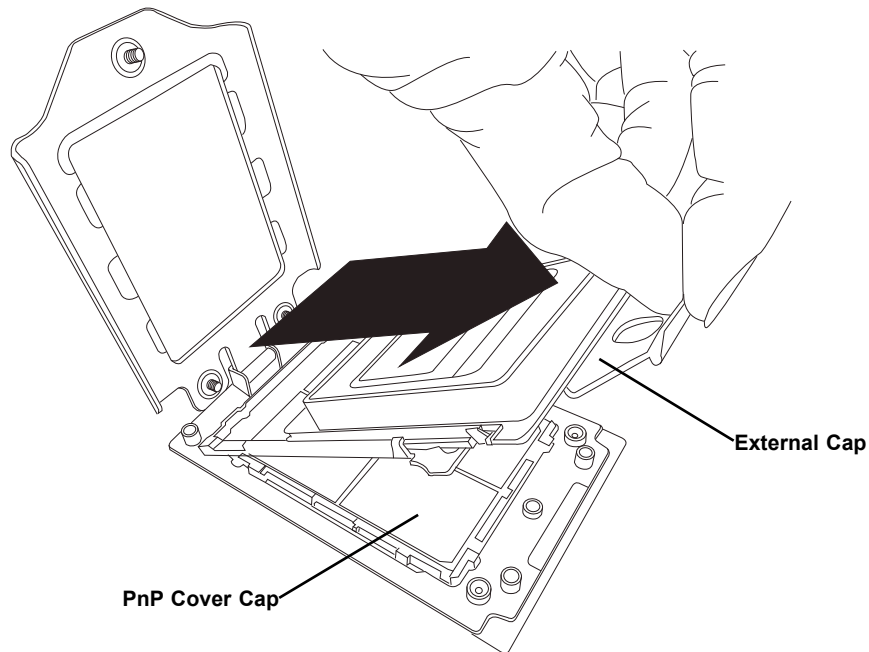

5. The CPU package is shipped from the factory with the blue carrier frame pre-assembled. Grip the handle of the carrier frame/CPU package assembly from its shipping tray, and while gripping the handle, align the flanges of the carrier frame onto the rails of the rail frame so its pins will be at the bottom when the rail frame is lowered later.
6. Slide the carrier frame/CPU package downwards to the bottom of the rail frame. Ensure the flanges are secure on the rails as you lower it downwards.

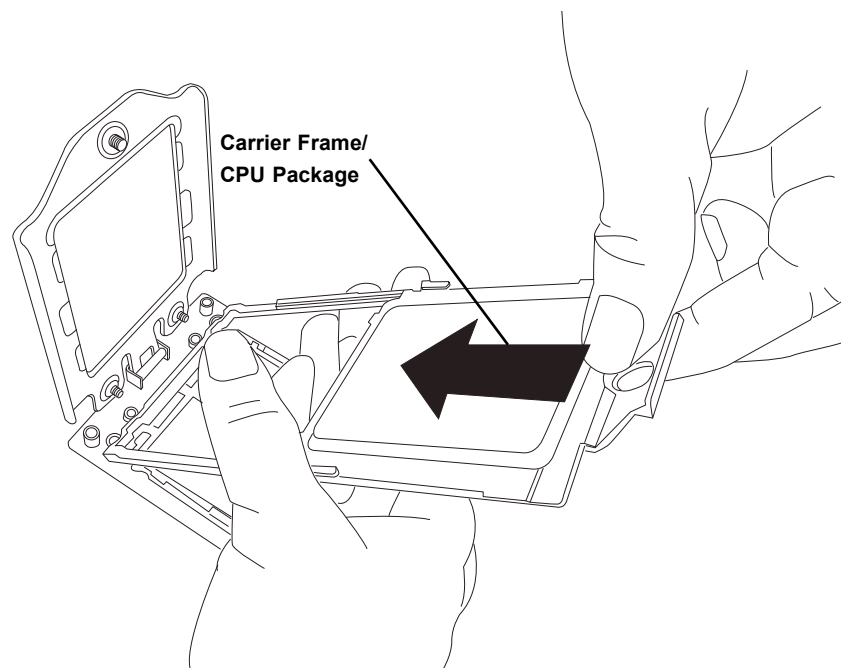

**Note:** You can only install the CPU inside the socket in one direction with the handle at the top. Make sure that it is properly inserted into the CPU socket before closing the rail frame plate. If it doesn't close properly, do not force it as it may damage your CPU. Instead, open the rail frame plate again, and double-check that the CPU is aligned properly.

7. Lift up the rail frame till it securely rests in upright position. Then remove the PnP cover cap from the CPU socket below. Grip the two lift tabs marked "Remove" at the middle of the cap and pull vertically upwards to remove the PnP cover cap.

**Important!** The exposed socket contacts are extremely vulnerable and can be damaged easily. Do not touch or drop objects onto the contacts and be careful removing the PnP cover cap and when placing the rail frame over the socket.

8. Gently lower the rail frame down onto the socket until the latches on the rail frame engage with the socket housing and it rests in place. **DO NOT** force it into place!

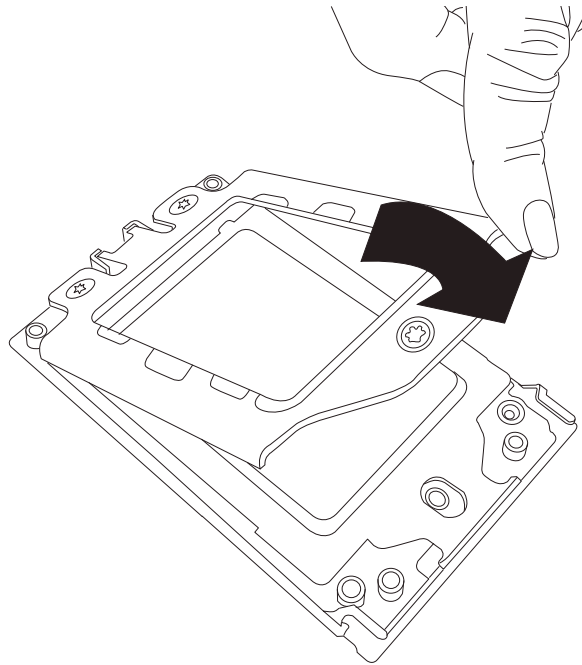

9. Gently lower the force frame down onto the rail frame and hold it in place until it is seated in the Socket housing. Note that the force frame is spring loaded and has to be held in place before it is secured. Important: Use a torque screwdriver, set it at 12.5 to 15.0 kgf-cm (10.8 to 13.0 in-lbf) with a Torx T20 screw head bit, to prevent damage to the CPU.

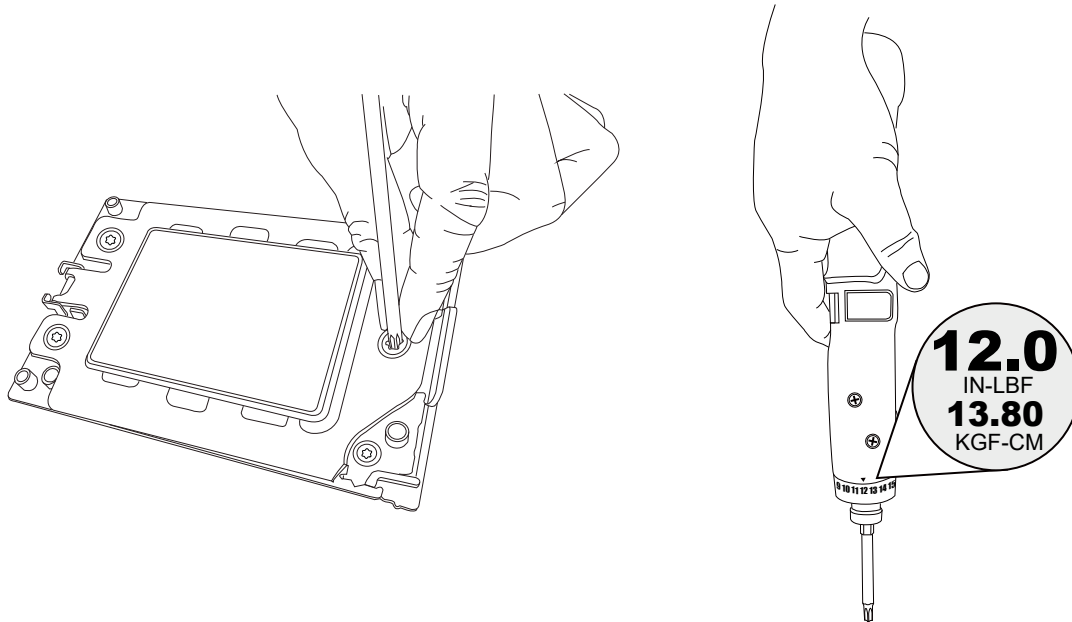

10. Place and re-screw the screws in the reverse order to the way you removed them (holes 1-2-3 in order). When finished, the force frame will be secure over both the rail frame and CPU package.

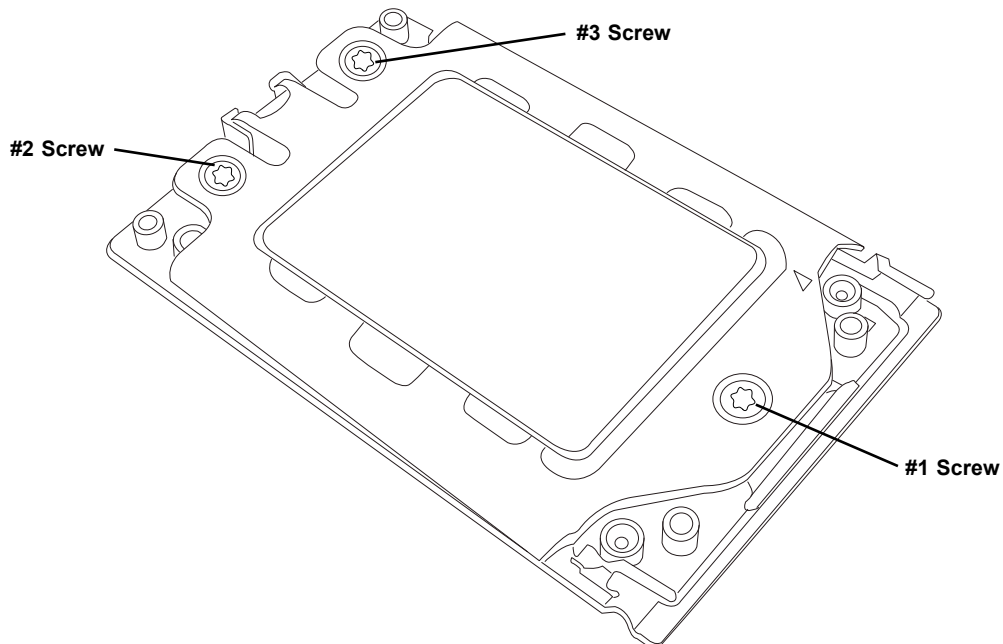

11. After the force frame is secured and the CPU package is in place, now you must install the heatsink to the frame. Lower the heatsink down till it rests securely over the four screw holes on CPU package on the socket frame.

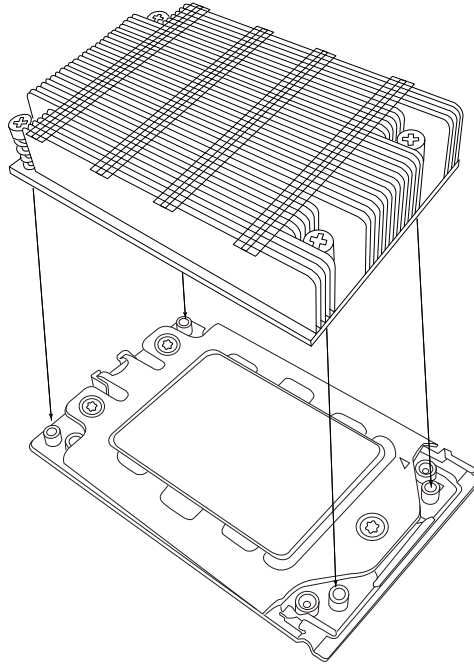

12. Secure the heatsink by tightening the four screws diagonally using a torque screwdriver set to 12.5 to 15.0 kgf-cm (10.8 to 13.0 in-lbf) in a clockwise direction until it is firmly in place. Your processor and heatsink are now installed on the motherboard. Repeat this procedure for any remaining CPU sockets on the motherboard.

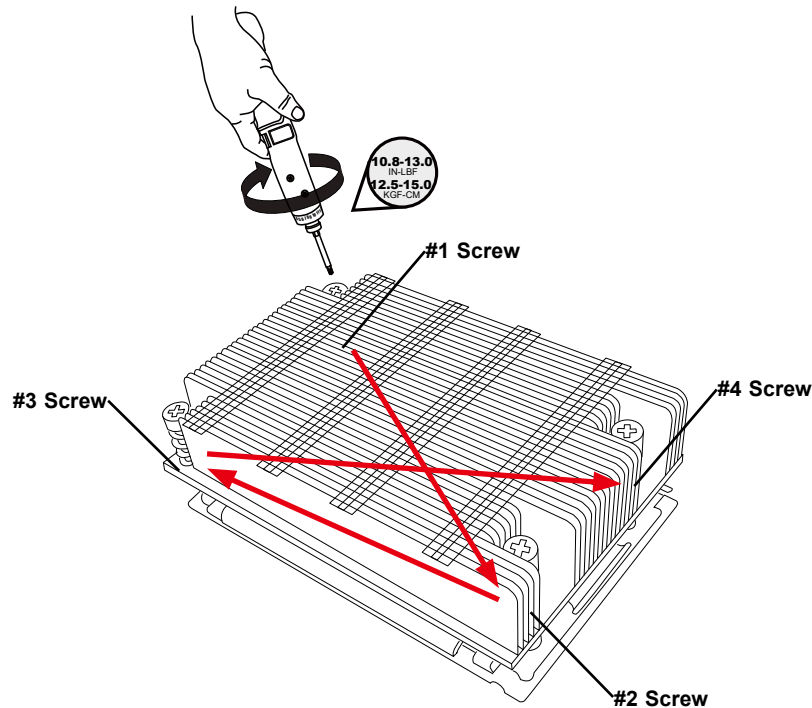

**Uninstalling the Processor and Heatsink**

1. Remove the heatsink attached to the top of the CPU package by reversing the installation procedure.
2. Clean the Thermal grease left by the heatsink on the CPU package lid to limit the risk of it contaminating the CPU package land pads or contacts in the socket housing.
3. Reverse the procedure for installing the force frame onto the socket, unscrewing the plate in the 3-2-1 screw order and lift the force frame to the vertical position.
4. Lift the rail frame using the lift tabs near the front end of the rail frame. Note that the rail frame is spring loaded, so be careful lifting it up into a vertical position.
5. Grip the handle of the carrier frame and pull upwards to extract it from the rail frame. Return the carrier frame/CPU package to its original shipping container.
6. Grip the handle on the external cap and return it to the rail frame sliding it downwards till it rests in the frame.
7. Gripping the rail frame, rotate it downwards till it rests above and locks over the socket housing in its horizontal position.
8. Push and rotate down the force frame till it is over the external cap and rail frame into a horizontal position.
9. While holding down the force frame, secure it back to the socket frame by securing screw 1 in place. Note that without a CPU package in place, it is not necessary to tighten down screws 2 and 3 at this time.

## 2.4 Memory Support and Installation

**Note:** Check the Supermicro website for recommended memory modules.

**Important:** Exercise extreme care when installing or removing DIMM modules to prevent any possible damage.

### Memory Support

The H13SVW-NT-OS2 supports up to 576 GB of ECC DDR5 4800 MT/s speed, RDIMM memory in six slots. Refer to the table below for additional memory information.

Populating RDIMM DDR5 Memory Modules with 8004 Processors				
Type	DIMM Population	Maximum DIMM Capacity (GB)		Maximum Frequency (MHz)
	DIMM1	1 Channel	6 Channels	
RDIMM	1Rx8	16 GB	96 GB	4800
	1Rx4	32 GB	192 GB	4800
	2Rx4	64 GB	384 GB	4800
	2Rx4	96 GB	576 GB	4800

## DIMM Module Population

When populating the motherboard with DIMM modules, please keep in mind the following:

- Always use DDR5 DIMM modules of the same type, size and speed.
- All six memory channels should be populated with each channel having equal capacity, which should provide the best performance in most cases.
- In most configurations, populating fewer than six channels is supported, but not recommended.

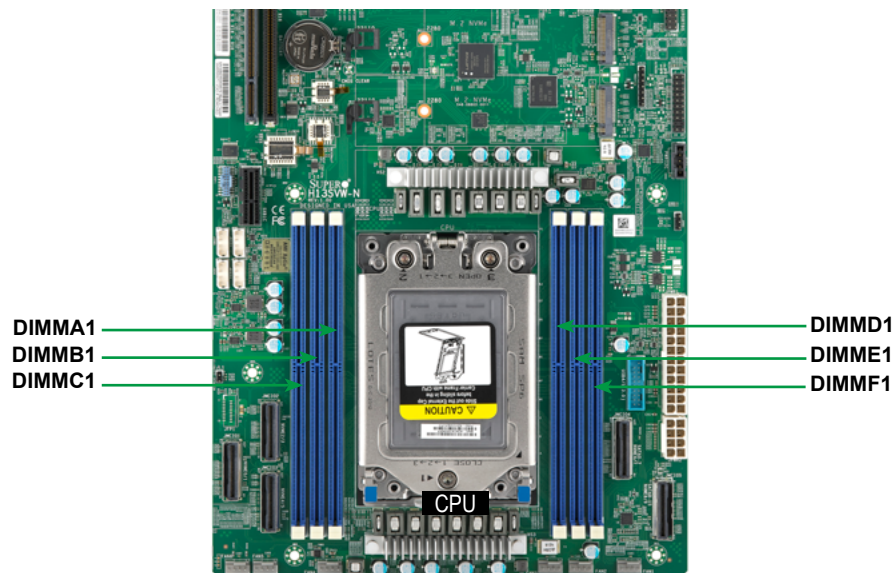
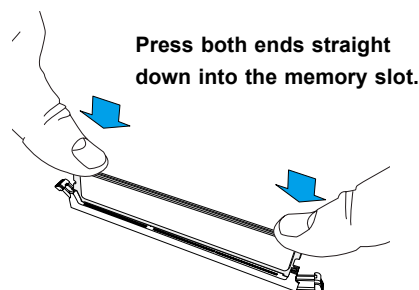
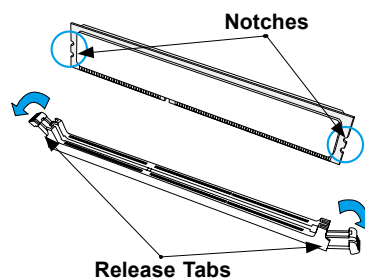
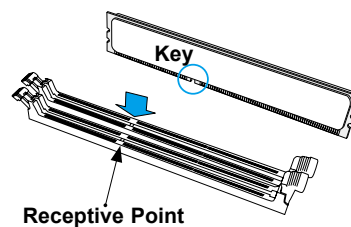

Figure 2-2. DIMM Numbering

Recommended Memory Channels						Node per Socket (NPS)
Channel						
C1	B1	A1	D1	E1	F1	
1 Channel						
		✓				NPS1
2 Channels						
		✓	✓			NPS2, NPS1
4 Channels						
✓		✓	✓		✓	NPS4, NPS2, NPS1
6 Channels						
✓	✓	✓	✓	✓	✓	NPS2, NPS1

## DIMM Installation

1. Insert the desired number of DIMMs into the memory slots, starting from DIMMA1. Refer to the [DIMM Module Population](#) section.
2. Push the release tabs outwards on both ends of the DIMM slot to unlock it.
3. Align the key of the DIMM module with the receptive point on the memory slot.
4. Align the notches on both ends of the module against the receptive points on the ends of the slot.
5. Press both ends of the module straight down into the slot until the module snaps into place.
6. Press the release tabs to the lock positions to secure the DIMM module into the slot.



## DIMM Removal

Press both release tabs on the ends of the DIMM module to unlock it. Once the DIMM module is loosened, remove it from the memory slot.

## 2.5 Rear I/O Ports

See the figure below for the locations and descriptions of the various I/O ports on the rear of the motherboard.

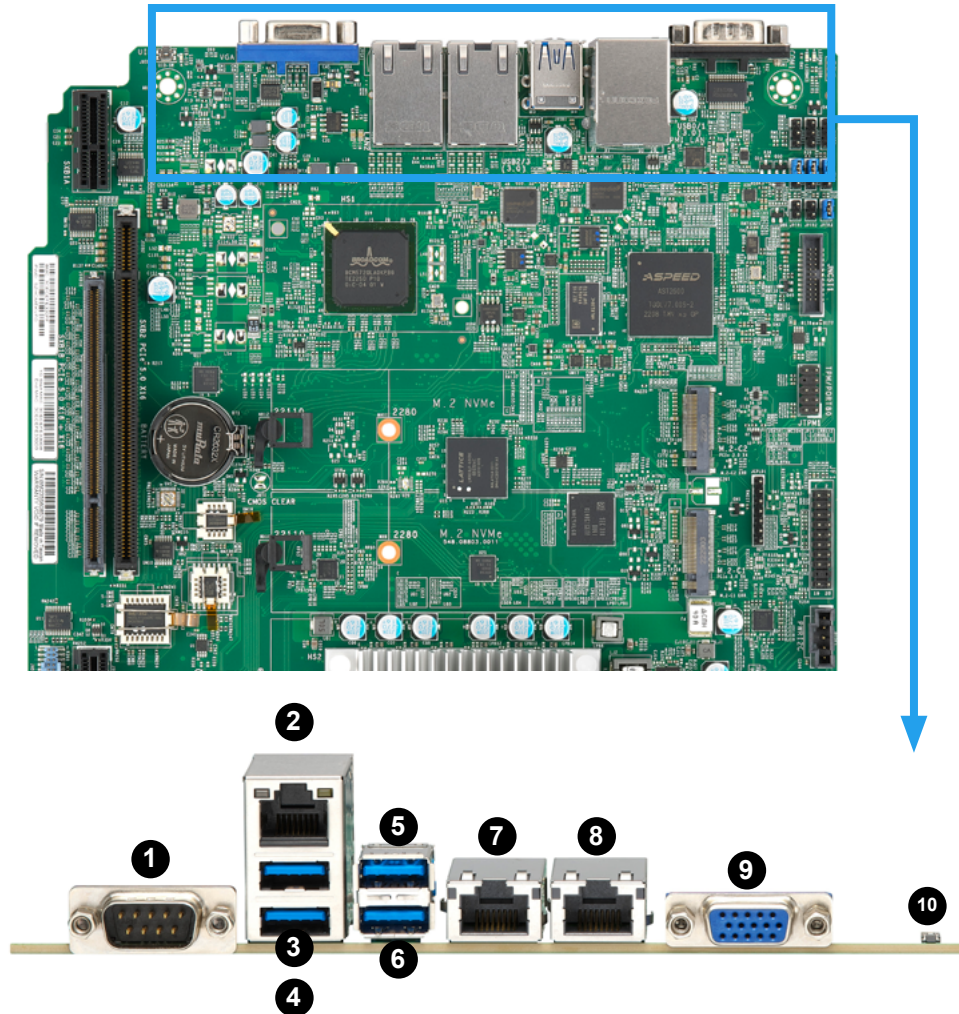

Figure 2-3. I/O Port Locations and Definitions

Rear I/O Ports					
#	Description	#	Description	#	Description
1	COM Port	5	USB 2 (3.0)	9	VGA Port
2	IPMI LAN Port	6	USB 3 (3.0)	10	UID Button & UID LED
3	USB 0 (3.0)	7	LAN Port #1		
4	USB 1 (3.0)	8	LAN Port #2		

**1. COM Port**

There is one serial communications port (COM1) on the rear I/O panel.

**2. IPMI LAN Port**

One IPMI LAN port is located on the I/O back panel. This port accepts an RJ45 type cable.

**3~6. Universal Serial Bus (USB) Ports**

There are four USB 3.0 ports (USB 0/1, 2/3) on the I/O back panel. These support the type A connector.

**7~8. LAN Ports**

There are two LAN ports located on the I/O back panel (LAN1 & LAN2). These ports accept RJ45 type cables.

**9. VGA Port**

There is one VGA port on the rear I/O panel.

**10. UID Button and UID LED Indicator**

A Unit Identifier (UID SW) switch and UID LED (LED9) are located on the I/O backpanel. The rear UID LED (LED9) is located next to the UID button. When you press the UID button, both rear and front UID LED indicators will turn on. Press the UID button again to turn off the LED indicators. The UID Indicator provides easy identification of a system that may be in need of service. See [2.6 Front Control Panel](#) for the front panel UID LED header location on JF1.

**Note:** UID can also be triggered via IPMI on the motherboard. For more information on IPMI, please refer to the IPMI User's Guide posted on our website at <http://www.supermicro.com>

## 2.6 Front Control Panel

JF1 contains header pins for various buttons and indicators that are normally located on a control panel at the front of the chassis. These connectors are designed specifically for use with Supermicro chassis. See the figure below for the location of JF1.

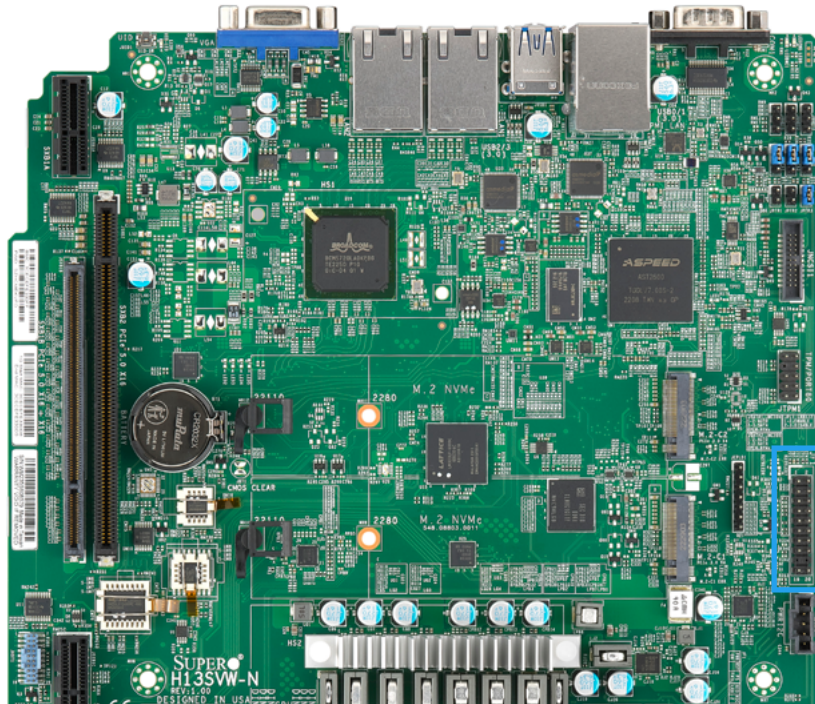

	1	2	
Power Switch	○	○	Ground
Reset Switch	○	○	Ground
Power Fail LED+	○	○	Power Fail LED
UID LED+	○	○	UID LED-
NIC2 LED+	○	○	NIC2 LED-
NIC1 LED+	○	○	NIC1 LED-
HDD LED+/UID Switch +	○	○	HDD LED-
Power LED+	○	○	Power LED-
KEY, no pin	○	○	KEY, no pin
NMI Switch Shift	○	○	Ground
	19	20	

Figure 2-4. JF1 Pin Definitions

## Front Control Panel Pin Definitions

### Power Switch

The Power Switch connection is located on pins 1 and 2 of JF1. Attach it to a hardware power switch on the computer case to power on/off the system. To force the system to be powered off, press the button for at least four seconds. Refer to the table below for pin definitions.

Power Switch Pin Definitions (JF1)	
Pin#	Definition
1	Power Switch
2	Grounds

### Reset Switch

The Reset Switch connection is located on pins 3 and 4 of JF1. Attach it to a hardware reset switch on the computer case to reset the system. Refer to the table below for pin definitions.

Reset Switch Pin Definitions (JF1)	
Pin#	Definition
3	Reset Switch
4	Ground

### Power Fail LED

The Power Fail LED connection is located on pins 5 and 6 of JF1.

Power Fail LED Pin Definitions (JF1)	
Pin#	Definition
5	Power Fail LED+
6	Power Fail LED-

Power Fail LED	
LED State	Status
Solid on	Overheat
Fast Blinking	Fan Fail
Slow Blinking	Power Fail

### Unit Identifier Button /UID LED Indicator

A Unit Identifier (UID) button is located on the I/O backplane, and two UID LED indicators are located on the serverboard. The rear UID LED is located next to the UID button. The front UID LED is located on pins 7 and 8 on the front control panel (JF1). When you press the UID button, both rear and front UID LED indicators will be turned on. Press the UID button again to turn off the LED indicators. The UID Indicators provide easy identification of a system unit that may be in need of service.

**Note:** UID can also be triggered via IPMI on the serverboard. For more information on IPMI, please refer to the IPMI User's Guide posted on our website at <http://www.supermicro.com>.

UID LED Pin Definitions (JF1)	
Pin#	Definition
7	UID LED+
8	UID LED-

### NIC1/NIC2 (LAN1/LAN2)

The NIC (Network Interface Controller) LED connection for LAN port 1 is located on pins 11 and 12 of JF1, and the LED connection for LAN Port 2 is on pins 9 and 10. Attach the NIC LED cables here to display network activity.

LAN1/LAN2 LED Pin Definitions (JF1)	
Pin#	Definition
9	NIC2 LED+
10	NIC2 LED-
11	NIC1 LED+
12	NIC1 LED-

### HDD LED/UID Button

The HDD LED/UID Button connection is located on pins 13 and 14 of JF1. Attach a cable to pin 14 to show hard drive activity status. Attach a cable to pin 13 to use UID button. Refer to the table below for pin definitions.

HDD LED Pin Definitions (JF1)	
Pin#	Definition
13	HDD LED+/UID Button+
14	HDD LED-

## Power LED

The Power LED connection is located on pins 15 and 16 of JF1. Attach a cable to pin 15 and pin 16 to show system power status. Refer to the table below for pin definitions.

Power LED Pin Definitions (JF1)	
Pin#	Definition
15	Power LED+
16	Power LED-

## NMI Switch

The non-maskable interrupt switch header is located on pins 19 and 20 of JF1. Attach it to a hardware NMI switch on the computer case to trigger the NMI. Refer to the table below for pin definitions.

NMI Switch Pin Definitions (JF1)	
Pin#	Definition
19	NMI Switch
20	Ground

## 2.7 Headers and Connectors

### Power Connections

#### 12V 8-pin Auxiliary Power Connector (JPWR2)

JPWR2 is an 8-pin ATX power input to provide auxiliary power to the processor. Refer to the table below for pin definitions.

12V 8-pin Power Connector Pin Definitions	
Pin#	Definition
1 through 4	Ground
5 through 8	+12 V

#### Main Power Supply Connector (JPWR1)

The primary power supply connector (JPWR1) is an ATX power connector that the power supply plugs directly into.

ATX Power 24-pin Connector Pin Definitions			
Pin#	Definition	Pin#	Definition
13	+3.3 V	1	+3.3 V
14	-12 V	2	+3.3 V
15	Ground	3	Ground
16	PS_ON	4	+5 V
17	Ground	5	Ground
18	Ground	6	+5 V
19	Ground	7	Ground
20	Res (NC)	8	PWR_OK
21	+5 V	9	5 VSB
22	+5 V	10	+12 V
23	+5 V	11	+12 V
24	Ground	12	+3.3 V

### Headers

#### Chassis Intrusion (JL1)

A Chassis Intrusion header is located at JL1 on the motherboard. Attach the appropriate cable from the chassis to the header to inform you when the chassis is opened.

Chassis Intrusion Pin Definitions	
Pin#	Definition
1	Ground
2	Intrusion Input

## Expansion Slots

The motherboard features several expansion slots. The table below describes each slot's type and speed.

Expansion Slots	
Name	Description
SXB1A	Riser Slot
SXB1B	Riser Slot (for CPU Slot1 PCIe 5.0 x16, Slot3, PCIe 5.0 x16)
SXB1C	Riser Slot
SXB2	CPU Slot5 PCIe 5.0 x16

## IPMB System Management Bus Header (JIPMB1)

A System Management Bus header for IPMI 2.0 is located at JIPMB1. Connect the appropriate cable here to use the IPMB I<sup>2</sup>C connection on your system.

IPMB Header Pin Definitions	
Pin#	Definition
1	Data
2	Ground
3	Clock
4	+3.3 V Stdby

## NVMe Ports (NVMe 0~5)

The H13SVW-NT-OS2 has six NVMe ports (two ports per one MCIO connector). These ports provide high-speed, low-latency PCIe 5.0 x4 connections directly from the CPU to NVMe Solid State (SSD) drives. This greatly increases SSD data-throughput performance and significantly reduces PCIe latency by simplifying driver/software requirements resulting from direct PCIe interface from the CPU to the NVMe SSD drives.

## Onboard Battery (BT1)

The onboard back up battery is located at BT1. The onboard battery provides backup power to the on chip CMOS, which stores the BIOS' setup information. It also provides power to the Real Time Clock (RTC) to keep it running.

### Onboard Fan Headers (FAN1~FAN6)

There are six fan headers on the motherboard. These are 4-pin fan headers; pins 1-3 are backward compatible with traditional 3-pin fans. The onboard fan speeds are controlled by Thermal Management (via Hardware Monitoring) in the BMC. When using Thermal Management setting, please use all 4-pin fans.

Fan Header Pin Definitions	
Pin#	Definition
1	Ground (Black)
2	+12 V (Red)
3	Tachometer (Yellow)
4	PWM Control (Blue)

### PCIe M.2 Connector (M.2-C1, M.2-C2)

The PCIe M.2 connectors are for devices such as memory cards, wireless adapters, etc. These devices must conform to the PCIe M.2 specifications (formerly known as NGFF). These particular PCIe M.2 supports M-Key (PCIe x4) storage cards.

### SATA/NVMe Hybrid Ports (SATA 0-7/NVMe 6-7; SATA 8-15/NVMe 8-9)

Each SATA/NVMe hybrid port can support up to eight SATA 3.0 ports or two NVMe ports (PCIe x4), for a total of 16 SATA ports or four NVMe ports.

### SPI TPM

A Trusted Platform Module (TPM)/Port 80 header is located at JTPM1 to provide TPM support and Port 80 connection. Use this header to enhance system performance and data security. Refer to the table below for pin definitions. Please go to the following link for more information on the TPM: <http://www.supermicro.com/manuals/other/TPM.pdf>.

Front Panel USB 3.0 Pin Definitions			
Pin#	Definition	Pin#	Definition
1	+3.3 V	2	SPI_CS#
3	RESET#	4	SPI_MISO
5	SPI_CLK	6	GND
7	SPI_MOSI	8	NCface
9	+3.3 V Stdby	10	SPI_IRQ#

### USB Ports (USB 0~3, USB 4/5)

There are a total of six USB ports supported on the motherboard. Four are located on the back panel; USB 0/1, and USB 2/3 (both are USB 3.1 compliant). There are two ports located on one header, USB 4/5 (3.1).

Front Panel USB 3.1 Pin Definitions			
Pin#	Definition	Pin#	Definition
1	VBUS	19	Power
2	USB3_P1_SSRX-	18	USB3_P2_SSRX-
3	USB3_P1_SSRX+	17	USB3_P2_SSRX+
4	GND	16	GND
5	USB3_P1_SSTX-	15	USB3_P2_SSTX-
6	USB3_P1_SSTX+	14	USB3_P2_SSTX+
7	GND	13	GND
8	USB_P1_N	12	USB_P2_N
9	USB_P1_P	11	USB_P2_P
10	GND		

## 2.8 Jumper Settings

### How Jumpers Work

To modify the operation of the motherboard, jumpers can be used to choose between optional settings. Jumpers create shorts between two pins to change the function of the connector. Pin #1 is identified with a thicker border line on the printed circuit board. See the diagram below for an example of jumping pins 1 and 2. Refer to the motherboard layout page for jumper locations.

**Note:** On two-pin jumpers, "Closed" means the jumper is on and "Open" means the jumper is off the pins.

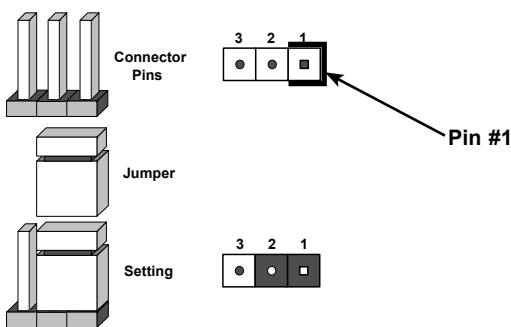

### Clear CMOS (JBT1)

JBT1 is used to clear CMOS, which will also clear any passwords. Instead of pins, this jumper consists of contact pads to prevent accidentally clearing the contents of CMOS.

#### **To Clear CMOS**

1. First power down the system and unplug the power cord(s).
2. Remove the cover of the chassis to access the motherboard.
3. Remove the onboard battery from the motherboard.
4. Short the CMOS pads with a metal object such as a small screwdriver for at least four seconds.
5. Remove the screwdriver (or shorting device).
6. Replace the cover, reconnect the power cord(s), and power on the system.

**Note:** Clearing CMOS will also clear all passwords.

*Do not use the PW\_ON connector to clear CMOS.*



### JSATA1/JSATA2

The 3-pin jumpers at JSATA1 and JSATA2 provide the option to switch the hybrid port (JMCI0 4/5) between SATA/NVMe. Refer to the table below for pin definitions.

JSATA1/JSATA2 Pin Definitions	
Pin#	Definition
1-2	Auto
2-3	SATA
Open	NVMe

### LAN Enable/Disable (JPL1)

Jumper JPL1 will enable or disable LAN1/LAN2. See below for jumper settings. The default setting is enabled.

GLAN Enable Jumper Settings	
Pin#	Definition
1-2	Enabled (default)
2-3	Disabled

## 2.9 LED Indicators

### BMC Heartbeat LED (LEDBMC1)

A BMC Heartbeat LED is located at LEDBMC1 on the motherboard. When LEDBMC1 is blinking, the BMC is functioning normally. See the table below for more information.

BMC Heartbeat LED State		
Color	State	Definition
Green	Solid On	BMC is not ready
Green	Blinking	BMC Normal
Green	Fast Blinking	BMC: Initializing

### BMC LAN Port LEDs

A dedicated BMC LAN is located on the rear I/O panel and has two LED indicators. The LED on the right indicates connection and activity, while the LED on the left indicates the speed of connection. The Link LED may be amber, or off to indicate the speed of the connection. Refer to the tables below for more information.

Link LED, Connection Link, Speed Indicator	
LED Color	Definition
Amber	1 Gb/s
Green	100 Mb/s
Off	10 Mb/s

Activity LED		
Color	State	Definition
None	No Connection	
Yellow	Solid On	Link
Yellow	Flashing	Active

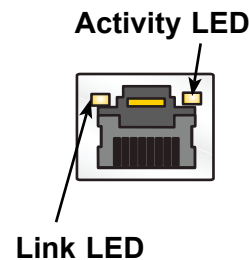

## Onboard LAN Port LEDs

The motherboard's Ethernet ports have two LED indicators. The Activity LED is green and indicates connection and activity. The Link LED may be green, orange/amber, or off to indicate the speed of the connection. Refer to the tables below for more information.

Link LED, Connection Link, Speed Indicator	
LED Color	Definition
Orange	1 Gb/s
Green	10 Gb/s

Activity LED		
Color	State	Definition
None	No Connection	
None	Off	Link
Green	Flashing	Active

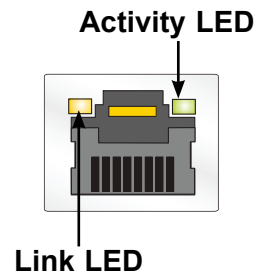

## Onboard Power OK LED (LED8)

LED8 is an onboard power OK LED. When this LED8 is lit, it means the system is turned on and all the system power rails are ready. When the system is turned off or any one of the system power rails fail, this LED will turn off. Turn off the system and unplug the power cable before removing or installing any component(s).

Onboard Power LED Indicator	
LED Color	Definition
Off	System Off (power cable not connected)
Green	System On, Power OK

## UID LED Indicator (LED9)

The rear LED9 is located next to the UID button. The front UID LED is located on the front panel. When you press the UID button, both rear LED9 and front UID LED indicators will turn on. Press the UID button again to turn off the LED indicators. Use this UID Indicator to "mark" the system, so the system can be easily identified whether on the front or back (e.g., a system rack with multiple units installed). See also UID LED.

UID LED LED Indicator		
Color	State	Definition
Blue	Solid On	Unit Identified
None	Off	UID Off

# Chapter 3

## Troubleshooting

### 3.1 Troubleshooting Procedures

Use the following procedures to troubleshoot your system. If you have followed all of the procedures below and still need assistance, refer to the "Technical Support Procedures" and/or "Returning Merchandise for Service" section(s) in this chapter. Always disconnect the AC power cord before adding, changing or installing any non hot-swap hardware components.

#### Before Power On

1. Check that the power LED on the motherboard is on.
2. Make sure that the power connector is connected to your power supply.
3. Make sure that no short circuits exist between the motherboard and chassis.
4. Disconnect all cables from the motherboard, including those for the keyboard and mouse.
5. Remove all add-on cards.
6. Install at least one DIMM, a CPU, and a heatsink (in that order), check all jumper settings. Make sure that the heatsink is fully seated.
7. Use the correct type of onboard CMOS battery (CR2032) as recommended by the manufacturer. To avoid possible explosion, do not install the CMOS battery upside down.

#### No Power

1. Check that the power LED on the motherboard is on.
2. Make sure that the power connector is connected to the power supply.
3. Check that the motherboard battery still supplies to 3 VDC. If it does not, replace it.
4. Check that the system input voltage is 100-120 V or 180-240 V.
5. Turn the power switch on and off to test the system.

## No Video

6. If the power is on but you have no video, remove all the add-on cards and cables.
7. Check if memory module population is supported following guidelines, and re-seat memory DIMM module(s).

**Note:** If you are a system integrator, VAR or OEM, a POST diagnostics card is recommended.

## System Boot Failure

If the system does not display POST (Power-On-Self-Test) or does not respond after the power is turned on, check the following:

1. Clear the CMOS settings by unplugging the power cord and contacting both pads on the CMOS Clear Jumper (JBT1). Refer to [Section 2.8](#).
2. Remove all components from the motherboard, especially the DIMM modules. Make sure that system power is on.
3. Turn on the system with only one DIMM module installed. If the system boots, check for bad DIMM modules or slots by following the Memory Errors Troubleshooting procedure in this Chapter.

## Memory Errors

4. Make sure that the DIMM modules are properly and fully installed.
5. Confirm that you are using the correct memory. Also, it is recommended that you use the same memory type and speed for all DIMMs in the system. See [Section 2.4](#) for memory details.
6. Check for bad DIMM modules or slots by swapping modules between slots and noting the results.
7. Check the power supply voltage 115 V / 230 V switch.

## When the System Keeps Losing its Setup Configuration

1. Use a high quality power supply. A poor quality power supply may cause the system to lose the CMOS setup information.
2. Check that the motherboard battery still supplies to 3 VDC. If it does not, replace it.
3. If the above steps do not fix the setup configuration problem, contact your vendor for repairs.

## If the System Becomes Unstable

### **A. If the system becomes unstable during or after OS installation, check the following:**

1. Processor/BIOS support: Make sure that your processor is supported and that you have the latest BIOS installed in your system.
2. Memory support: Make sure that the memory modules are supported. Refer to the product page on our website at <https://www.supermicro.com>. Test the modules using memtest86 or a similar utility.

**Note:** Refer to the product page on our website at <http://www.supermicro.com> for memory and CPU support and updates.

3. Storage Drive support: Make sure that all storage drives work properly. Replace the failed storage drives with good ones.
4. System cooling: Check the system cooling to make sure that all heatsink fans and processor/system fans, etc., work properly. Check the hardware monitoring settings in the IPMI to make sure that the processor and system temperatures are within the normal range. Also, check the front panel Overheat LED and make sure that it is not on.
5. Adequate power supply: Make sure that the power supply provides adequate power to the system. Make sure that all power connectors are connected. Please refer to our website for more information on the minimum power requirements.
6. Proper software support: Make sure that the correct drivers are used.

### **B. If the system becomes unstable before or during OS installation, check the following:**

1. Source of installation: Make sure that the devices used for installation are working properly, including boot devices such as USB flash or media drives.
2. Cable connection: Check to make sure that all cables are connected and working properly.
3. Using the minimum configuration for troubleshooting: Remove all unnecessary components (starting with add-on cards first), and use the minimum configuration (but with a CPU and a memory module installed) to identify the trouble areas. Refer to the steps listed in Section A above for proper troubleshooting procedures.
4. Identifying bad components by isolating them: If necessary, remove a component in question from the chassis, and test it in isolation to make sure that it works properly. Replace a bad component with a good one.
5. Check and change one component at a time instead of changing several items at the same time. This will help isolate and identify the problem.

6. To find out if a component is good, swap this component with a new one to see if the system will work properly. If so, then the old component is bad. You can also install the component in question in another system. If the new system works, the component is good and the old system has problems.

## 3.2 Technical Support Procedures

Before contacting Technical Support, please take the following steps. Also, note that as a motherboard manufacturer, we do not sell directly to end-users, so it is best to first check with your distributor or reseller for troubleshooting services. They should know of any possible problem(s) with the specific system configuration that was sold to you.

1. Please review the 'Troubleshooting Procedures' and 'Frequently Asked Questions' (FAQs) sections in this chapter or see the FAQs on our website before contacting Technical Support.
2. BIOS upgrades can be downloaded from our website.

**Note:** Not all BIOS can be flashed depending on the modifications to the boot block code.

3. If you still cannot resolve the problem, include the following information when contacting us for technical support:
  - Motherboard model and PCB revision number
  - BIOS release date/version (this can be seen on the initial display when your system first boots up)
  - System configuration

An example of a Technical Support form is posted on our website.

<https://webpr3.supermicro.com/SupportPortal>.

Distributors: For immediate assistance, please have your account number ready when contacting our technical support department by e-mail.

## 3.3 Frequently Asked Questions

**Question:** What type of memory does my motherboard support?

**Answer:** The H13SVW-NT-OS2 motherboard supports up to 576 GB of ECC DDR5 4800 MT/s speed, RDIMM memory in six slots. See [Section 2.4](#) for details on installing memory.

**Question: How do I update my BIOS?**

**Answer:** It is recommended that you do not upgrade your BIOS if you are not experiencing any problems with your system. Updated BIOS files are located on our website at <http://www.supermicro.com>.

To update your BIOS:

1. Check the BIOS warning message and the information on how to update your BIOS from our website.
2. Select your motherboard model and check the current BIOS revision to make sure it is newer than your motherboard's installed BIOS before downloading.
3. Download the zip file and save the BIOS package to your computer.
4. Unzip the BIOS files onto a USB stick with a FAT/FAT32 file system.
5. Boot to the motherboard's built-in UEFI Shell and type the following to start the BIOS update process:

```
FLASH.nsh BIOSname#.### <ENTER>
```

**Note:** Supermicro no longer supports the BIOS update method in DOS.

6. Perform an A/C power cycle after the message indicating the BIOS update has completed. You may refer to the "Readme" file in BIOS package for more details.

**Question: Why can't I turn off the power using the momentary power on/off switch?**

**Answer:** The instant power off function is controlled in BIOS by the Power Button Mode setting. When the On/Off feature is enabled, the motherboard will have instant off capabilities as long as the BIOS has control of the system. When the Standby or Suspend feature is enabled or when the BIOS is not in control such as during memory count (the first screen that appears when the system is turned on), the momentary on/off switch must be held for more than four seconds to shut down the system. This feature is required to implement the ACPI features on the motherboard.

**Question: When I run setup.exe to install AMD I/O drivers under windows, the Installshield wizard shows "Unable to save file: C:\AMD\AMD\_Chipset\_Drivers\..... The system cannot find the path specified."**

**Answer:** This happens under specific environments. Please click "OK," and Installshield will prompt you to save the drivers to a folder you designate. It will then run the driver installation automatically.

## 3.4 Returning Merchandise for Service

A receipt or copy of your invoice marked with the date of purchase is required before any warranty service will be rendered. You can obtain service by calling your vendor for a Returned Merchandise Authorization (RMA) number. When returning to the manufacturer, the RMA number should be prominently displayed on the outside of the shipping carton and mailed prepaid or hand-carried. Shipping and handling charges will be applied for all orders that must be mailed when service is complete.

For faster service, RMA authorizations may be requested online (<http://www.supermicro.com/support/rma/>).

This warranty only covers normal consumer use and does not cover damages incurred in shipping or from failure due to the alteration, misuse, abuse or improper maintenance of products.

During the warranty period, contact your distributor first for any product problems.

## 3.5 Battery Removal and Installation

### Battery Removal

To remove the onboard battery, follow the steps below:

1. Power off your system and unplug your power cable.
2. Locate the onboard battery as shown below.
3. Using a tool such as a pen or a small screwdriver, push the battery lock outwards to unlock it. Once unlocked, the battery will pop out from the holder.
4. Remove the battery.

### Proper Battery Disposal

Please handle used batteries carefully. Do not damage the battery in any way; a damaged battery may release hazardous materials into the environment. Do not discard a used battery in the garbage or a public landfill. Please comply with the regulations set up by your local hazardous waste management agency to dispose of your used battery properly.

## Battery Installation

1. To install an onboard battery, follow the steps 1 and 2 above and continue below:
2. Identify the battery's polarity. The positive (+) side should be facing up.
3. Insert the battery into the battery holder and push it down until you hear a click to ensure that the battery is securely locked.

**Important:** When replacing a battery, be sure to only replace it with the same type.

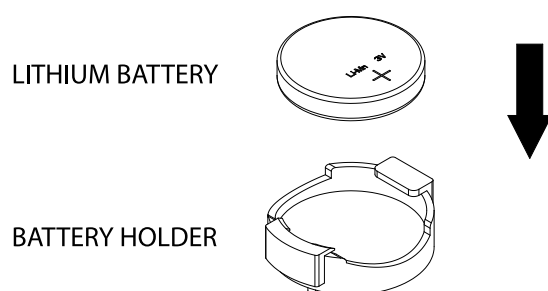

# Chapter 4

## UEFI BIOS

### 4.1 Introduction

This chapter describes the AMIBIOS™ Setup utility for the H13SVW-NT-OS2 motherboard. The BIOS is stored on a chip and can be easily upgraded using a flash program.

**Note:** Due to periodic changes to the BIOS, some settings may have been added or deleted and might not yet be recorded in this manual. Please refer to the Manual Download area of our website for any changes to BIOS that may not be reflected in this manual.

#### Starting the Setup Utility

To enter the BIOS Setup Utility, hit the <Delete> key while the system is booting-up. (In most cases, the <Delete> key is used to invoke the BIOS setup screen. There are a few cases when other keys are used, such as <F1>, <F2>, etc.) Each main BIOS menu option is described in this manual.

The Main BIOS screen has two main frames. The left frame displays all the options that can be configured. “Grayed-out” options cannot be configured. The right frame displays the key legend. Above the key legend is an area reserved for a text message. When an option is selected in the left frame, it is highlighted in white. Often a text message will accompany it. (Note that BIOS has default text messages built in. We retain the option to include, omit, or change any of these text messages.) Settings printed in **Bold** are the default values.

A " ►" indicates a submenu. Highlighting such an item and pressing the <Enter> key will open the list of settings within that submenu.

The BIOS setup utility uses a key-based navigation system called hot keys. Most of these hot keys (<F1>, <F2>, <F3>, <Enter>, <ESC>, <Arrow> keys, etc.) can be used at any time during the setup navigation process.

## 4.2 Main Setup

When you first enter the AMI BIOS setup utility, you will enter the Main setup screen. You can always return to the Main setup screen by selecting the Main tab on the top of the screen. The Main BIOS setup screen is shown below. The following Main menu items will be displayed:

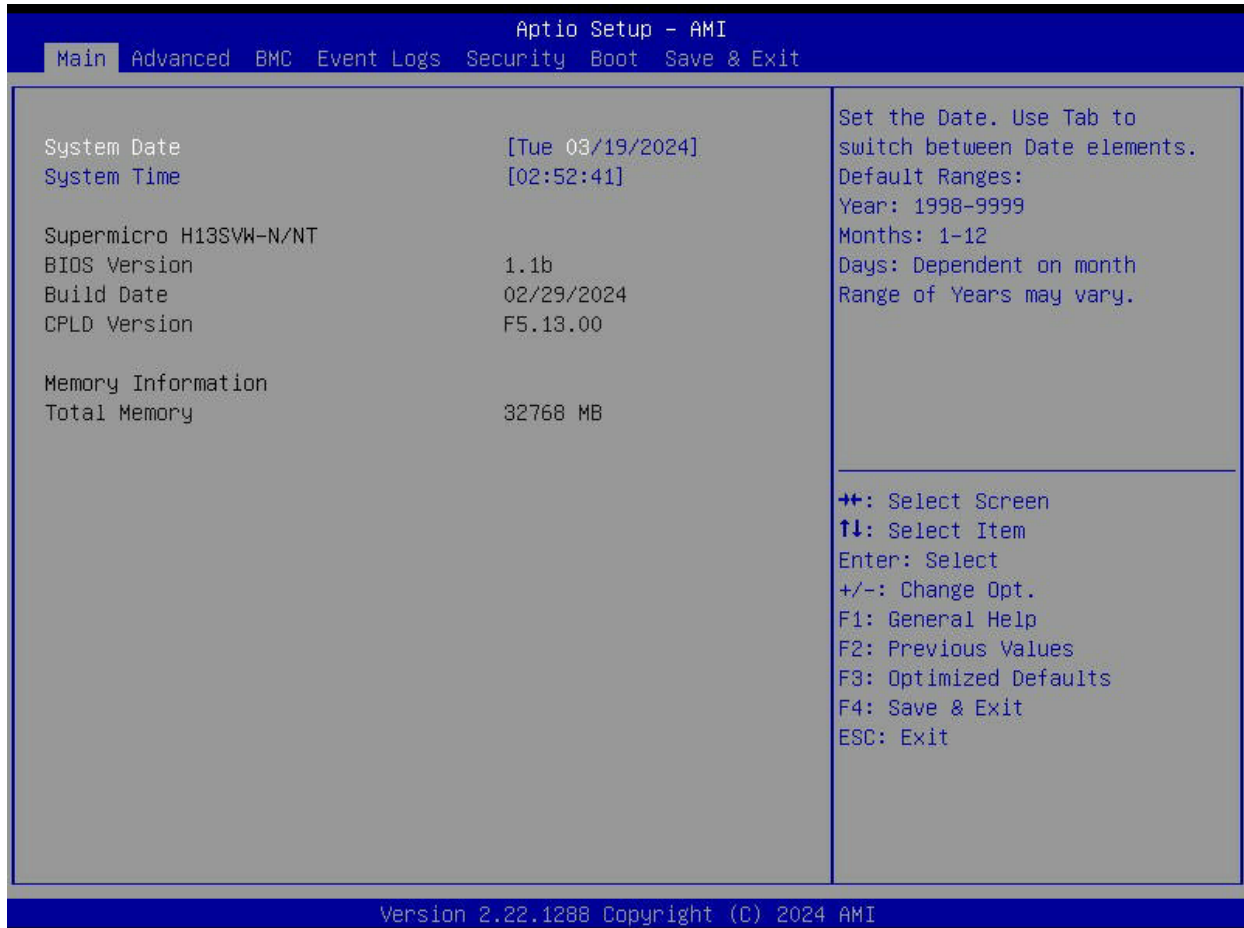

### System Date/System Time

Use this option to change the system date and time. Highlight *System Date* or *System Time* using the arrow keys. Enter new values using the keyboard. Press the <Tab> key or the arrow keys to move between fields. The date must be entered in MM/DD/YYYY format. The time is entered in HH:MM:SS format.

**Note:** The time is in the 24-hour format. For example, 5:30 P.M. appears as 17:30:00. The date's default value is 01/01/2015 after RTC reset.

### Supermicro H13SVW-NT-OS2

#### BIOS Version

This item displays the version of the BIOS ROM used in the system.

**Build Date**

This item displays the date when the version of the BIOS ROM used in the system was built.

**CPLD Version**

This item displays the CPLD version of the BIOS ROM used in the system.

**Memory Information**

**Total Memory**

This feature displays the total system memory detected.

## 4.3 Advanced

Use the arrow keys to select a top item and press the <Enter> key to access the submenu items.

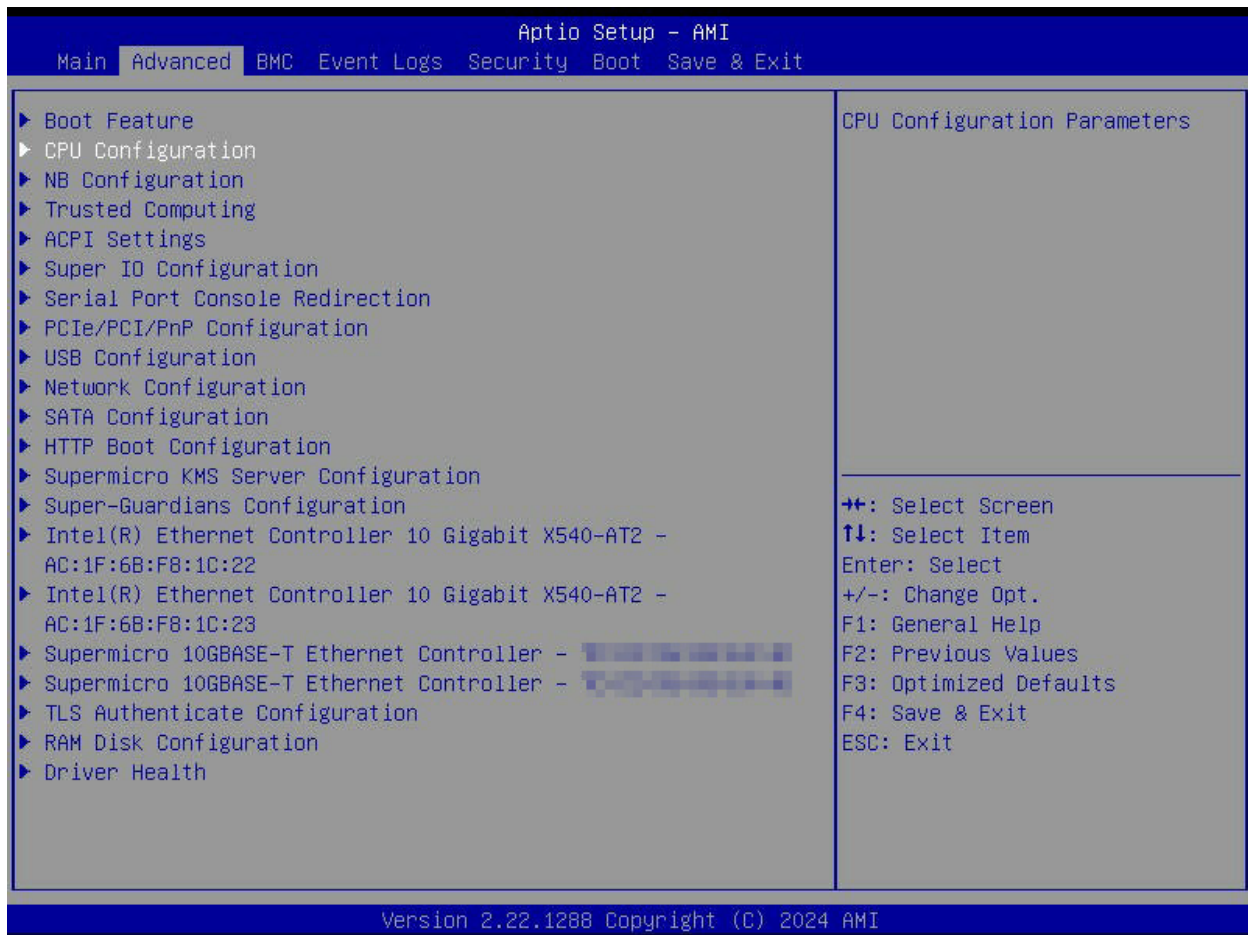

**Warning:** Take caution when changing the Advanced settings. An incorrect value, a very high DRAM frequency, or an incorrect DRAM timing setting may make the system unstable. When this occurs, revert to the default to the manufacture default settings.

### ► Boot Feature

#### Quiet Boot

Use this feature to select the screen display between the POST messages and the OEM logo upon bootup. Select Disabled to display the POST messages. Select Enabled to display the OEM logo instead of the normal POST messages. The options are Disabled and **Enabled**.

#### Option ROM Messages

Use this feature to set the display mode for the Option ROM. Select Keep Current to display the current AddOn ROM setting. Select Force BIOS to use the Option ROM display set by the system BIOS. The options are **Force BIOS** and Keep Current.

**Bootup NumLock State**

Use this feature to set the Power on state for the <Numlock> key. The options are **On** and Off.

**Wait For "F1" If Error**

Use this feature to force the system to wait until the <F1> key is pressed if an error occurs. The options are Disabled and **Enabled**.

**INT19 (Interrupt 19) Trap Response**

Interrupt 19 is the software interrupt that handles the boot disk function. When this item is set to Immediate, the ROM BIOS of the host adaptors will "capture" Interrupt 19 at bootup immediately and allow the drives that are attached to these host adaptors to function as bootable disks. If this item is set to Postponed, the ROM BIOS of the host adaptors will not capture Interrupt 19 immediately and allow the drives attached to these adaptors to function as bootable devices at bootup. The options are **Immediate** and Postponed.

**Re-try Boot**

If this item is enabled, the BIOS will automatically reboot the system from a specified boot device after its initial boot failure. The options are **Disabled**, Legacy Boot, and EFI Boot.

**Power Configuration****Watch Dog Function**

If enabled, the Watch Dog Timer will allow the system to reset or generate NMI based on jumper settings when it is expired for more than 5 minutes. The options are **Disabled** and Enabled.

**Restore on AC Power Loss**

Use this feature to set the power state after a power outage. Select Stay-Off for the system power to remain off after a power loss. Select Power-On for the system power to be turned on after a power loss. Select Last State to allow the system to resume its last power state before a power loss. The options are Power Off, Power On, and **Last State**.

**Power Button Function**

This feature controls how the system shuts down when the power button is pressed. Select 4 Seconds Override for the user to power off the system after pressing and holding the power button for 4 seconds or longer. Select Instant Off to instantly power off the system as soon as the user presses the power button. The options are **Instant Off** and 4 Seconds Override.

## ▶ CPU Configuration

### **SMT Control**

Use this setting to specify Simultaneous Multithreading. The options are Disabled, Enabled, and **Auto**.

### **Core Performance Boost**

This setting is used to configure for Core Performance Boost. The options include Disabled and **Auto**.

### **Global C-state Control**

This setting is used to configure for Global C-state Control. The options include Disabled, Enabled, and **Auto**.

### **SEV-ES ASID Space Limit**

The default value is 1.

### **Local APIC Mode**

The options include Compatibility, xAPIC, x2APIC, and **Auto**.

### **PPIN Opt-in**

The options include Disabled, Enabled, and **Auto**.

### **SNP Memory (RMP Table) Coverage**

The options include Disabled, Enabled, Custom, and **Auto**.

### **SMEE**

The options include Disabled, Enabled, and **Auto**.

### **AVX512**

This setting is used to enable or disable AVX512. The options include Disabled, Enabled, and **Auto**.

### **Monitor and MWAIT Disable**

When this setting is set Enabled, the MONITOR, MWAIT, MONITORX, AND WAITX opcodes become invalid. The options include Enabled, Disabled, and **Auto**.

### **L1 Stream HW Prefetcher**

This setting is used to enable or disable the L1 Stream Hardware Prefetcher. The options are Disabled, Enabled, and **Auto**.

### **L2 Stream HW Prefetcher**

This setting is used to enable or disable the L2 Stream Hardware Prefetcher. The options are Disabled, Enabled, and **Auto**.

### **CCD Control**

The options include **Auto**, 2 CCDs, 4 CCDs, 6 CCDs, 8 CCDs, and 10 CCDs.

### **Core Control**

This sets the number of cores to be used by your system. Once this option has been used to remove any cores, a power cycle is required in order for the future selections to take effect. Options include **Auto**, ONE (1+0), TWO (2 + 0), THREE (3+0), FOUR (4+0), FIVE (5+0), SIX (6 + 0), SEVEN (7+0), TWO (1+1), FOUR (2+2), SIX (3+3), EIGHT (4+4), TEN (5+5), TWELVE (6+6), and FOURTEEN (7+7). If unsure, leave this to Auto.

### **SVM Mode**

This setting Disables or **Enables** CPU Virtualization.

## **▶ CPU1 Information**

These sections are for informational purposes. They will display some details about the detected CPUs on the motherboard, such as:

- CPU Version
- Number of Cores Running
- Processor Family
- Processor Model
- Microcode Patch Level
- L1 Instruction Cache (Size/Method)
- L1 Data Cache (Size/Method)
- L2 Data Cache (Size/Method)
- L3 Cache per Socket (Size/Method)

### **CPU1 PCIe Package Group P2**

The options include **Auto**, x4x4x4x4, x4x4x8, x8x4x4, x8x8, and x16.

### **CPU1 PCIe Package Group G2**

The options include **Auto**, x4x4x4x4, x4x4x8, x8x4x4, x8x8, and x16.

### **CPU1 PCIe Package Group P3**

The options include **Auto**, x4x4x4x4, x4x4x8, x8x4x4, x8x8, and x16.

**CPU1 PCIe Package Group G3**

The options include **Auto**, x4x4x4x4, x4x4x8, x8x4x4, x8x8, and x16.

**CPU1 PCIe Package Group P1**

The options include **Auto**, x4x4x4x4, x4x4x8, x8x4x4, x8x8, and x16.

**CPU1 PCIe Package Group G1**

The options include **Auto**, x4x4x4x4, x4x4x8, x8x4x4, x8x8, and x16.

**CPU1 PCIe Package Group P0**

The options include **Auto**, x4x4x4x4, x4x4x8, x8x4x4, x8x8, and x16.

**CPU1 PCIe Package Group G0**

The options include **Auto**, x4x4x4x4, x4x4x8, x8x4x4, x8x8, and x16.

**►NB Configuration****North Bridge Configuration****IOMMU**

Use this setting to enable or disable IOMMU. The options include Disabled, Enabled, and **Auto**.

**TDP Control**

Use this setting to configure the cTDP Control. The options include Manual and **Auto**.

**Package Power Limit Control**

Use this setting to . The options include Manual and **Auto**.

**Determinism Slider**

Use this setting to configure the Determinism Slider. The options include Manual and **Auto**.

**APBDIS**

The options include 0, 1, and **Auto**.

**Power Profile Selection**

The options include **High Performance Mode**, Efficiency Mode, and Maximum I/O Performance Mode.

**DF Cstates**

The options include Disabled, Enabled, and **Auto**.

**Data Link Feature Cap**

The options include Enabled, Disabled, and **Auto**.

## SEV-SNP Support

The options include Disable, Enable, and **Auto**.

### ▶ Memory Configuration

#### Memory Target Speed

This setting allows you to specify the memory target speed in MT/s. The options include **Auto**, DDR3200, DDR3600, DDR4000, DDR4400, DDR4800, DDR5200, and DDR5600.

#### Memory Interleaving

This setting controls fabric level memory interleaving. Note that the channel, die and socket have requirements on memory populations and it will be ignored if the memory doesn't support the selected option. The options are Disabled and **Auto**.

#### Chipset Interleaving

This setting controls interleave memory blocks across the DRAM chip for node 0. The options are Disabled and **Auto**.

#### BankSwapMode

This setting controls . The options are **Auto**, Disabled, and Swap CPU.

#### Power Down Enable

Use this setting to enable or disable DDR power down mode. The options include Disabled, Enabled, and **Auto**.

#### DRAM Scrub Time

This setting provides a value that is the number of hours to scrub memory. The options are Disabled, 1 hour, 4 hours, 8 hours, 16 hours, **24 hours**, 48 hours, and Auto.

#### TSME

Use this setting to enable or disable TSME. The options include Disabled, Enabled, and **Auto**.

#### Enhanced PPR

The options are **Disabled**, and Enabled.

### ▶ CPU1 Memory Information

These sections are for informational purposes. They will display some details about the detected memory according to each CPU on the motherboard, such as:

- Detected Size (per slot, in MB)
- Current Speed (MT/s)

## ▶ Trusted Computing

### Security Device Support

If this feature and the TPM jumper on the motherboard are both set to Enabled, onboard security devices will be enabled for TPM (Trusted Platform Module) support to enhance data integrity and network security. Please reboot the system for a change on this setting to take effect. The options are Disabled and **Enabled**.

## ▶ ACPI Settings

### High Precision Event Timer

The High Precision Event Timer (HPET) can produce periodic interrupts and is used to synchronize multimedia streams, providing smooth playback and reducing the need to use other timestamp calculations. The options are Disabled and **Enabled**.

### PCI AER Support

Use this setting to enable or disable ACPI OS to natively manage PCI Advanced Error Reporting. The options are **Disabled** and Enabled.

### NUMA Nodes Per Socket

This feature specifies the number of desired Non-Uniform Memory Access (NUMA) nodes per socket. Setting this to zero will attempt to interleave the two sockets together. The options are NPS0, NPS1, NPS2, NPS4 and **Auto**.

### ACPI SRAT L3 Cache As NUMA Domain

Select Enabled for each CCX in the system to be declared as a separate NUMA domain. Select Disabled for Memory Addressing/NUMA nodes per socket to be declared. The options are Disabled, Enabled, and **Auto**.

## ▶ Super IO Configuration

The following Super IO information will display:

- Super IO Chip AST2600

## ▶ Serial Port 1 Configuration

### Serial Port

Select Enabled to enable the selected onboard serial port. The options are Disabled and **Enabled**.

## Device Settings

This item displays the status of a serial port specified by the user.

## Change Settings

This feature specifies the base I/O port address and the Interrupt Request address of a serial port specified by the user. Select Auto to allow the BIOS to automatically assign the base I/O and IRQ address. The options are **Auto**, (IO=3F8h; IRQ=4;), (IO=3F8h; IRQ=3, 4, 5, 6, 7, 9, 10, 11, 12;), (IO=2F8h; IRQ=3, 4, 5, 6, 7, 9, 10, 11, 12;), (IO=3E8h; IRQ=3, 4, 5, 6, 7, 9, 10, 11, 12;), and (IO=2E8h; IRQ=3, 4, 5, 6, 7, 9, 10, 11, 12;).

## ► Serial Port 2 Configuration

### Serial Port

Select Enabled to enable the selected onboard serial port. The options are Disabled and **Enabled**.

### Device Settings

This item displays the status of a serial port specified by the user.

### Change Settings

This feature specifies the base I/O port address and the Interrupt Request address of a serial port specified by the user. Select Auto to allow the BIOS to automatically assign the base I/O and IRQ address. The options are **Auto**, (IO=2F8h; IRQ=3;), (IO=3F8h; IRQ=3, 4, 5, 6, 7, 9, 10, 11, 12;), (IO=2F8h; IRQ=3, 4, 5, 6, 7, 9, 10, 11, 12;), (IO=3E8h; IRQ=3, 4, 5, 6, 7, 9, 10, 11, 12;), and (IO=2E8h; IRQ=3, 4, 5, 6, 7, 9, 10, 11, 12;).

## ► Serial Port Console Redirection

### COM1

#### Console Redirection

Select Enabled to enable console redirection support for a serial port specified by the user. The options are **Disabled** and Enabled.

***\*If the item above is set to Enabled, the following items will become available for user's configuration:***

#### ► Console Redirection Settings

##### Terminal Type

This feature allows the user to select the target terminal emulation type for Console Redirection. Select VT100 to use the ASCII Character set. Select VT100+ to add color

and function key support. Select ANSI to use the Extended ASCII Character Set. Select VT-UTF8 to use UTF8 encoding to map Unicode characters into one or more bytes. The options are VT100, **VT100+**, VT-UTF8, and ANSI.

### **Bits per second**

Use this feature to set the transmission speed for a serial port used in Console Redirection. Make sure that the same speed is used in the host computer and the client computer. A lower transmission speed may be required for long and busy lines. The options are 9600, 19200, 38400, 57600 and **115200** (bits per second).

### **Data Bits**

Use this feature to set the data transmission size for Console Redirection. The options are 7 and **8**.

### **Parity**

A parity bit can be sent along with regular data bits to detect data transmission errors. Select Even if the parity bit is set to 0, and the number of 1's in data bits is even. Select Odd if the parity bit is set to 0, and the number of 1's in data bits is odd. Select None if you do not want to send a parity bit with your data bits in transmission. Select Mark to add a mark as a parity bit to be sent along with the data bits. Select Space to add a Space as a parity bit to be sent with your data bits. The options are **None**, Even, Odd, Mark, and Space.

### **Stop Bits**

A stop bit indicates the end of a serial data packet. Select 1 Stop Bit for standard serial data communication. Select 2 Stop Bits if slower devices are used. The options are **1** and 2.

### **Flow Control**

Use this feature to set the flow control for Console Redirection to prevent data loss caused by buffer overflow. Send a "Stop" signal to stop sending data when the receiving buffer is full. Send a "Start" signal to start sending data when the receiving buffer is empty. The options are **None** and Hardware RTS/CTS.

### **VT-UTF8 Combo Key Support**

Select Enabled to enable VT-UTF8 Combination Key support for ANSI/VT100 terminals. The options are Disabled and **Enabled**.

### **Recorder Mode**

Select Enabled to capture the data displayed on a terminal and send it as text messages to a remote server. The options are **Disabled** and Enabled.

### **Resolution 100x31**

Select Enabled for extended-terminal resolution support. The options are Disabled and **Enabled**.

### Legacy OS Redirection Resolution

Use this feature to select the number of rows and columns used in Console Redirection for legacy OS support. The options are 80x24 and **80x25**.

### Putty KeyPad

This feature selects the settings for Function Keys and KeyPad used for Putty, which is a terminal emulator designed for the Windows OS. The options are VT100, LINUX, XTERMR6, SC0, ESCN, and VT400.

### Redirection After BIOS POST

Use this feature to enable or disable legacy console redirection after BIOS POST. When set to Bootloader, legacy console redirection is disabled before booting the OS. When set to Always Enable, legacy console redirection remains enabled when booting the OS. The options are **Always Enable** and BootLoader.

## SOL

### Console Redirection

Select Enabled to enable SOL console redirection support for a serial port specified by the user. The options are Disabled and **Enabled**.

***\*If the item above set to Enabled, the following items will become available for user's configuration:***

### ► Console Redirection Settings

#### Terminal Type

This feature allows the user to select the target terminal emulation type for Console Redirection. Select VT100 to use the ASCII Character set. Select VT100+ to add color and function key support. Select ANSI to use the Extended ASCII Character Set. Select VT-UTF8 to use UTF8 encoding to map Unicode characters into one or more bytes. The options are VT100, **VT100+**, VT-UTF8, and ANSI.

#### Bits per second

Use this feature to set the transmission speed for a serial port used in Console Redirection. Make sure that the same speed is used in the host computer and the client computer. A lower transmission speed may be required for long and busy lines. The options are 9600, 19200, 38400, 57600 and **115200** (bits per second).

#### Data Bits

Use this feature to set the data transmission size for Console Redirection. The options are 7 and **8**.

### Parity

A parity bit can be sent along with regular data bits to detect data transmission errors. Select Even if the parity bit is set to 0, and the number of 1's in data bits is even. Select Odd if the parity bit is set to 0, and the number of 1's in data bits is odd. Select None if you do not want to send a parity bit with your data bits in transmission. Select Mark to add a mark as a parity bit to be sent along with the data bits. Select Space to add a Space as a parity bit to be sent with your data bits. The options are **None**, Even, Odd, Mark, and Space.

### Stop Bits

A stop bit indicates the end of a serial data packet. Select 1 Stop Bit for standard serial data communication. Select 2 Stop Bits if slower devices are used. The options are **1** and **2**.

### Flow Control

Use this feature to set the flow control for Console Redirection to prevent data loss caused by buffer overflow. Send a "Stop" signal to stop sending data when the receiving buffer is full. Send a "Start" signal to start sending data when the receiving buffer is empty. The options are **None** and Hardware RTS/CTS.

### VT-UTF8 Combo Key Support

Select Enabled to enable VT-UTF8 Combination Key support for ANSI/VT100 terminals. The options are Disabled and **Enabled**.

### Recorder Mode

Select Enabled to capture the data displayed on a terminal and send it as text messages to a remote server. The options are **Disabled** and Enabled.

### Resolution 100x31

Select Enabled for extended-terminal resolution support. The options are Disabled and **Enabled**.

### Legacy OS Redirection Resolution

Use this feature to select the number of rows and columns used in Console Redirection for legacy OS support. The options are 80x24 and **80x25**.

### Putty KeyPad

This feature selects the settings for Function Keys and KeyPad used for Putty, which is a terminal emulator designed for the Windows OS. The options are **VT100**, LINUX, XTERMR6, SC0, ESCN, and VT400.

### Redirection After BIOS POST

Use this feature to enable or disable legacy console redirection after BIOS POST. When set to Bootloader, legacy console redirection is disabled before booting the OS. When set

to Always Enable, legacy console redirection remains enabled when booting the OS. The options are **Always Enable** and BootLoader.

### **Legacy Console Redirection Settings**

#### **Legacy Serial Redirection Port**

For this setting, select a COM port to display redirection of Legacy OS and Legacy OPRM messages. The options include **COM1** and SOL.

#### **Serial Port for Out-of-Band Management / Windows Emergency Management Services (EMS)**

##### **Console Redirection**

Select Enabled to enable EMS console redirection support for a serial port specified by the user. The options are **Disabled** and Enabled.

***\*If the item above set to Enabled, the following items will become available for user's configuration:***

### **► Console Redirection Settings**

#### **Out-of-Band Mgmt Port**

The feature selects a serial port in a client server to be used by the Microsoft Windows Emergency Management Services (EMS) to communicate with a remote host server. The options are **COM1**, and SOL.

#### **Terminal Type**

Use this feature to select the target terminal emulation type for Console Redirection. Select VT100 to use the ASCII character set. Select VT100+ to add color and function key support. Select ANSI to use the extended ASCII character set. Select VT-UTF8 to use UTF8 encoding to map Unicode characters into one or more bytes. The options are VT100, VT100+, **VT-UTF8**, and ANSI.

#### **Bits per Second**

This item sets the transmission speed for a serial port used in Console Redirection. Make sure that the same speed is used in the host computer and the client computer. A lower transmission speed may be required for long and busy lines. The options are 9600, 19200, 57600, and **115200** (bits per second).

#### **Flow Control**

Use this item to set the flow control for Console Redirection to prevent data loss caused by buffer overflow. Send a "Stop" signal to stop sending data when the receiving buffer is full. Send a "Start" signal to start sending data when the receiving buffer is empty. The options are **None**, Hardware RTS/CTS, and Software Xon/Xoff.

**Data Bits**

**Parity**

**Stop Bits**

## ► **PCIe/PCI/PnP Configuration**

This menu provides PCIe/PCI/PnP configuration settings and information.

### **PCI Bus Driver Version**

#### **PCI Devices Common Settings:**

##### **Above 4G Decoding**

This setting Disables or **Enables** 64-bit capable devices ability to be decoded in above 4G address space (only if the system supports 64-bit PCI decoding).

##### **Re-Size BAR Support**

This setting is used to enable or disable Resizable BAR Support. The options are **Disabled** and Enabled.

##### **SR-IOV Support**

If the system has SR-IOV capable PCIe devices, this setting will **Disable** or Enable the Single Root IO Virtualization Support for the system.

##### **BME DMA Mitigation**

Use this setting to re-enable the Bus Master Attribute that was disabled during PCI enumeration for PCI bridges after SMM is locked. The options are **Disabled** and Enabled.

##### **PCIe Speed PWM Control**

. The options are Dynamic link speed determined by Power Management functionality, Static Target Link Speed (GEN4), Static Target Link Speed (GEN5), and **Auto**.

##### **ASPM Support**

The options are **Disabled**, Auto, and Force L0s.

##### **PCIe ARI Support**

The options are Disabled, Enabled, and **Auto**.

##### **PCIe ARI Enumeration**

The options are Disable, Enable, and **Auto**.

**Relaxed Ordering**

Use this setting to enable or disable PCI Express Device Relaxed Ordering. The options are Disabled and **Enabled**.

**Clock Spread Spectrum**

Use this setting to enable or disable PCIe Spread Spectrum. The options are **Disabled** and Enabled.

**No Snoop**

Use this setting to enable or disable PCI Express Device No Snoop option. The options are Disabled and **Enabled**.

**VGA Priority**

Use this setting to select between onboard or offboard VGA support. The options are **Onboard** and External.

**PCIe Ten Bit Tag Support**

Use this setting to enable or disable PCIe ten bit tags for supported devices. The options are Disable, Enable, and **Auto**.

**NVMe Firmware Source**

Use this setting to select between the AMI Native firmware support or the device vendor-defined firmware support. The options are **Vendor Defined Firmware** and AMI Native Support.

**Onboard LAN**

Use this setting to enable or disable the onboard LAN feature. The options are Disabled and **Enabled**.

**Onboard Video Option ROM**

Use this setting to select which onboard video firmware type is to be loaded. The options include Disabled, **Legacy** and EFI.

**Onboard LAN1 Option ROM**

Use this setting to select which option ROM is to be loaded for onboard LAN1 on the system. The options include Disabled, and EFI.

**► USB Configuration****Legacy USB Support**

Select Enabled to support onboard legacy USB devices. Select Auto to disable legacy support if there are no legacy USB devices present. Select Disable to have all USB devices available for EFI applications only. The options are **Enabled**, Disabled and Auto.

### **XHCI Hand-Off**

This is a work-around solution for operating systems that do not support XHCI (Extensible Host Controller Interface) hand-off. The XHCI ownership change should be claimed by the XHCI driver. The options are **Enabled**, and Disabled.

### **Port 60/64 Emulation**

Select Enabled for I/O port 60h/64h emulation support, which in turn, will provide complete legacy USB keyboard support for the operating systems that do not support legacy USB devices. The options are Disabled and **Enabled**.

## **► Network Configuration**

### **Network Stack**

Use this setting to enable or disable UEFI Network Stack. The options include Disabled and **Enabled**.

### **IPv4 PXE Support**

Use this setting to enable or disable IPv4 PXE boot support. The options include Disabled and **Enabled**.

### **IPv4 HTTP Support**

Use this setting to enable or disable IPv4 HTTP boot support. The options include **Disabled** and Enabled.

### **IPv6 PXE Support**

Use this setting to enable or disable IPv6 PXE boot support. The options include Disabled and **Enabled**.

### **IPv6 HTTP Support**

Use this setting to enable or disable IPv6 HTTP boot support. The options include **Disabled** and Enabled.

### **PXE Boot Wait Time**

Use this feature to specify the wait time to press the <ESC> key to abort the PXE boot. Press the <+> or <-> key on your keyboard to change the value. The default setting is **0**.

### **Media Detect Count**

Use this feature to specify the number of times presence of media will be checked. Press the <+> or <-> key on your keyboard to change the value. The default setting is **1**.

## **► SATA Configuration**

This section displays the detected SATA devices installed on the system.

**SATA Enable**

Use this setting to disable or enable OnChip SATA controller. The options are Disabled, Enabled, and **Auto**.

**▶SATA Information**

This item displays information on the detected SATA devices connected and are detected.

**▶HTTP Boot Configuration****HTTP Boot Configuration****HTTP Boot Policy**

The options are Apply to all LANs, **Apply to each LAN**, and Boot Priority #1 instantly.

**Priority of HTTP Boot****Instance of Priority 1**

Rank targeted port

**Select IPv4 or IPv6**

Target LAN port is boot from IPv4 or IPv6.

**Boot Description**

This option is an input field that, when the HTTP boot option is created, can be used to enter text to describe or identify the HTTP connection.

**Boot URI**

This option is an input field used to enter a web or network address to point to the HTTP boot files. This supports the HTTP or HTTPS protocols only.

**Instance of Priority 2****▶Supermicro KMS Server Configuration****Super KMS Server IP address****Second Supermicro KMS Servr IP address****Suprmicro KMS TCP Port number****KMS Time Out****TimeZone****Client Userame**

## Client Password

### ▶ CA Certificate

### ▶ Client Certificate

### ▶ Client Private Key

## ▶ Super-Guardians Configuration

### Super-Guardians Protection Policy

The options are **Storage**, System, and System and Storage.

### KMS Security Policy

The options are **Disabled**, and Enabled.

### KMS Server Retry Count

The test connection to Key Manage Server ranges from 0 to 10. The default value is 5.

### TPM Security Policy

The options are **Disabled**, and Enabled.

### Load Authentication-Key

The options are **Disabled**, and Enabled.

### USB Security Policy

The options are **Disabled**, and Enabled.

## ▶ Supermicro 10GBASE-T Ethernet Controller

### ▶ Firmware Configuration Menu

### ▶ Device Configuration Menu

### ▶ MBA Configuration Menu

#### Blink LEDs

#### Link Status

#### Physical Link Speed

**Chip Type**

**PCI Device ID**

**Bus:Device:Function**

**Permanent MAC Address**

**Virtual MAC Address**

**Restore Defaults**

## ▶ **TLS Authenticate Configuration**

Press the <Enter> key to configure Server CA.

### ▶ **Enroll Certification**

#### ▶ **Enroll Certification Using File**

Use this feature to enroll certification from a file.

#### **Certification GUID**

Use this feature to input the certification GUID.

#### ▶ **Enroll Certification Using File**

This feature allows the user to enroll the security certificate in the system by using a file.

#### ▶ **Commit Changes and Exit**

Select this feature to keep the changes you have made and exit from the system.

#### ▶ **Discard Changes and Exit**

Select this feature to discard the changes you have made and exit from the system.

#### ▶ **Delete Certification**

The options are **Disabled** and Enabled.

## ▶ **RAM Disk Configuration**

### **Disk Memory Type**

The options include **Boot Service Data**, and Reserved.

**▶ Create raw**

The options are **Disabled** and Enabled.

**▶ Create from file**

Use this setting to create a RAM disk from a given file.

**Remove selected RAM disk(s)****▶ Driver Health****▶ Broadcom NXE Gigabit Ethernet Driver**

Use this setting to view health status of drivers or controllers.

## 4.4 BMC

This tab allows you to configure the following IPMI settings for the system.



### BMC Firmware Revision

This item indicates the IPMI firmware revision used in your system.

### BMC Status

This item indicates the status of the IPMI firmware installed in your system.

## ▶ System Event Log

### Enabling/Disabling Options

#### SEL Components

Select Enabled for all system event logging at bootup. The options are Disabled and Enabled.

## Erasing Settings

### Erase SEL

Select Yes, On next reset to erase all system event logs upon next system reboot. Select Yes, On every reset to erase all system event logs upon each system reboot. Select No to keep all system event logs after each system reboot. The options are **No**, Yes, On next reset, and Yes, On every reset.

### When SEL is Full

This feature allows the user to decide what the BIOS should do when the system event log is full. Select Erase Immediately to erase all events in the log when the system event log is full. The options are **Do Nothing** and Erase Immediately.

**Note:** After making changes on a setting, be sure to reboot the system for the changes to take effect.

## ► BMC Network Configuration

### BMC Network Configuration

#### Update BMC LAN Configuration

Select **Yes** to enable BMC Network Configuration.

#### Configure IPv4 support

#### BMC LAN Selection

This item displays the IPMI LAN setting. The default setting is **Failover**.

#### BMC Network Link Status

This item displays the IPMI Network Link status. The default setting is **Dedicated LAN**.

***\*If the item "Update IPMI LAN Configuration" above is set to Yes, the following item will become available for configuration:***

#### Configuration Address Source

This feature allows the user to select the source of the IP address for this computer. If Static is selected, you will need to know the IP address of this computer and enter it to the system manually in the field. If DHCP is selected, the BIOS will search for a DHCP (Dynamic Host Configuration Protocol) server in the network that is attached to and request the next available IP address for this computer. The options are **DHCP** and Static.

***\*If the item above is set to Static, the following items will become available for configuration:***

**Station IP Address**

This item displays the Station IP address for this computer. This should be in decimal and in dotted quad form.

**Subnet Mask**

This item displays the sub-network that this computer belongs to. The value of each three-digit number separated by dots should not exceed 255.

**Station MAC Address**

This item displays the Station MAC address for this computer. Mac addresses are 6 two-digit hexadecimal numbers

**Gateway IP Address**

This item displays the Gateway IP address for this computer. This should be in decimal and in dotted quad form (i.e., 172.31.0.1).

**VLAN**

This item displays the virtual LAN settings. The options are Disable and Enable.

**Configure IPv6 Support**

This section displays configuration features for IPv6 support.

**IPv6 address status****IPv6 Support**

Use this feature to enable IPv6 support. The options are **Enabled** and Disabled.

***\*If the item "IPv6 Support" above is set to Enabled, the item Configuration Address Source will become available.***

**Configuration Address Source**

This feature allows the user to select the source of the IP address for this computer. If Static is selected, you will need to know the IP address of this computer and enter it to the system manually in the field. If DHCP is selected, the BIOS will search for a DHCP (Dynamic Host Configuration Protocol) server in the network that is attached to and request the next available IP address for this computer. The options are Static and **DHCP**.

***\*If the item "Configuration Address Source" above is set to Static, the following items will become available for configuration:***

- Station IPv6 Address
- Prefix Length
- IPv6 Router1 IP Address

**Configure VLAN Support****LAN channel 1****VLAN Support**

This setting is used to specify the VLAN ID. The options include Enabled, Disabled, and **Unspecified**.

**Current Configuration Address Source**

*\*If the item "VLAN Support" above is set to Enabled, the following items will become available for configuration:*

**VLAN ID****VLAN Priority**

## 4.5 Event Logs

This tab allows the user to configure the following event logs settings for the system.



### ▶ Change SMBIOS Event Log Settings

This feature allows the user to configure SMBIOS Event settings.

#### Enabling/Disabling Options

##### SMBIOS Event Log

Select Enabled to enable SMBIOS (System Management BIOS) Event Logging during system boot. The options are Disabled and **Enabled**.

#### Erasing Settings

##### Erase Event Log

Select Yes to erase all error events in the SMBIOS (System Management BIOS) log before an event logging is initialized at bootup. The options are **No**, Yes, Next reset, and Yes, every reset.

**When Log is Full**

Select Erase Immediately to immediately erase all errors in the SMBIOS event log when the event log is full. Select Do Nothing for the system to do nothing when the SMBIOS event log is full. The options are **Do Nothing** and Erase Immediately.

**SMBIOS Event Log Standard Settings****Log System Boot Event**

Select Enabled to log system boot events. The options are **Disabled** and Enabled.

**MECI (Multiple Event Count Increment)**

Enter the increment value for the multiple event counter. Enter a number between 1 to 255. The default setting is **1**.

**METW (Multiple Event Count Time Window)**

This item is used to determine how long (in minutes) the multiple event counter should wait before generating a new event log. Enter a number between 0 to 99. The default setting is **60**.

**Note:** Please reboot the system for these changes to take effect.

**►View SMBIOS Event Log**

When Event Logging is on, this item allows the user to view the entries in the SMBIOS event log. The following categories are displayed:

**Date/Time/Error Code/Severity**

## 4.6 Security

This tab allows you to configure the following security settings for the system.

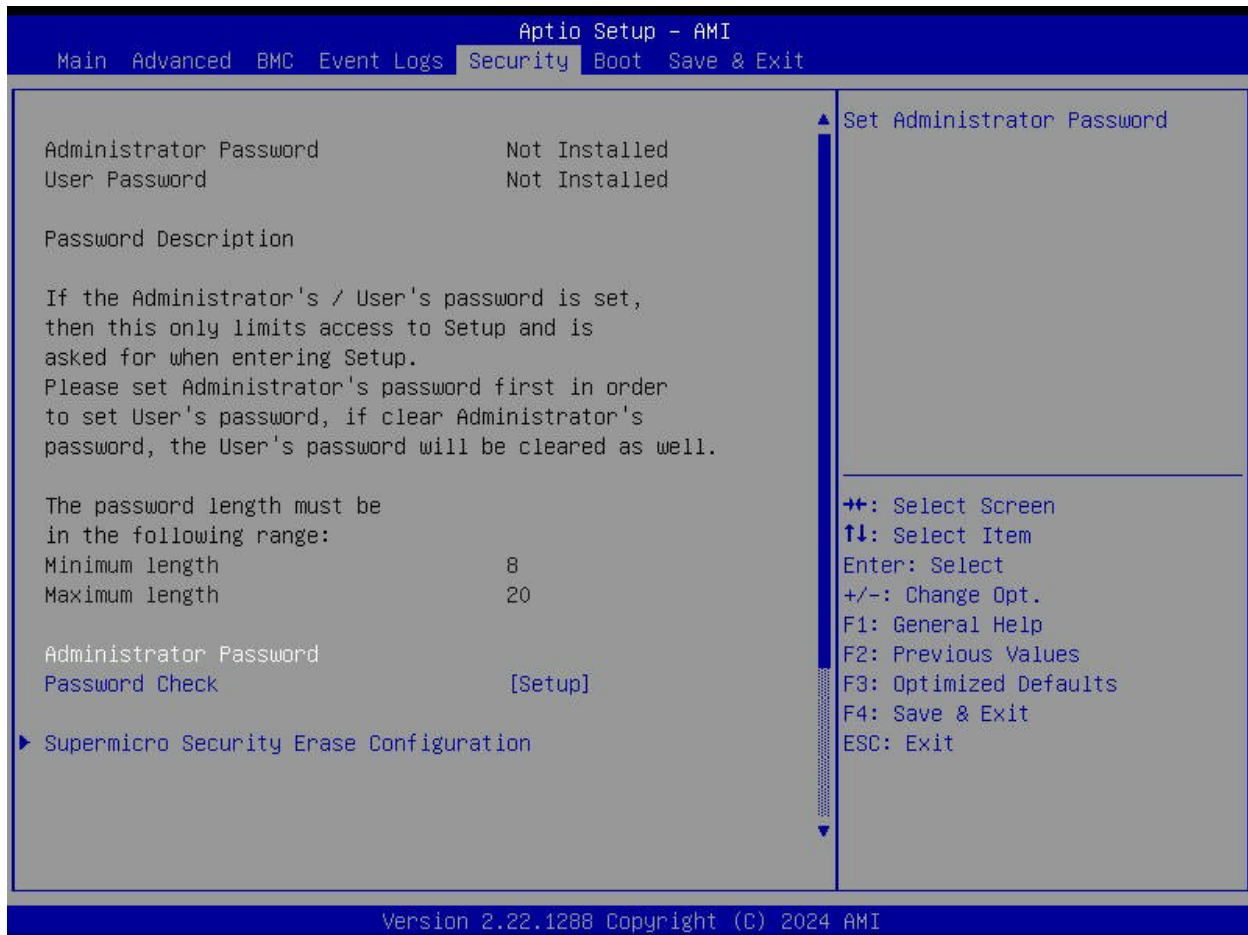

### Administrator Password

Press the <Enter> key to create a new, or change an existing Administrator password. Note that if the Administrator Password is erased, the User Password will be cleared as well.

### User Password

Press the <Enter> key to create a new, or change an existing User password.

### Password Check

Select Setup for the system to check for a password at Setup. Select Always for the system to check for a password at bootup or upon entering the BIOS Setup utility. The options are **Setup** and **Always**.

## ▶SMCI Security Erase Configuration

### ▶Secure Boot

This section contains options and menus for securing your boot mode and for key management.

#### **Secure Boot**

This option allows you specify when the Platform Key (PK) is enrolled. When enabled, the System Mode is user deployed, and the CSM function is disabled. The options include **Disabled** and **Enabled**.

#### **Secure Boot Mode**

Use this item to select the secure boot mode. The options are Standard and **Custom**.

#### **CSM Support**

Select Enabled to support the EFI Compatibility Support Module (CSM), which provides compatibility support for traditional legacy BIOS for system boot. The options are Disabled and **Enabled**.

### ▶Enter Audit Mode

### ▶Enter Deployed Mode

Transition between Deployment and User Modes

### ▶Key Management

This submenu allows the user to configure the following Key Management settings.

#### **Provision Factory Defaults**

Installing factory default Secure Boot keys after the platform reset and while the system is in Setup mode. The options include **Disabled** and **Enabled**.

#### ▶Restore Factory Keys

This feature forces system to User Mode. Install factory default Secure Boot key databases. The options include **Yes** and **No**.

#### ▶Reset To Setup Mode

This feature deletes all Secure Boot key databases from NVRAM. The options include **Yes** and **No**.

### ▶ Export Secure Boot variables

This feature copies NVRAM content of Secure Boot variables to files in a root folder on a file system device.

### ▶ Enroll EFI Image

This allows the image to run in Secure Boot Mode, and enroll SHA256 hash of the binary into an Authorized Signature Database (db).

## Device Guard Ready

### ▶ Remove 'UEFI CA' from DB

Device Guard ready system must not list 'Microsoft UEFI CA' Certificate in Authorized Signature database (db). Options include Yes and No.

### ▶ Restore DB defaults

This feature allows the user to restore DB variables to factory defaults. Options include Yes and No.

### ▶ Platform Key (PK)

This feature allows the user to configure the settings of the platform keys. Options include Details, Export, Update, and Delete.

#### **Set New Key**

Select Yes to load the new platform keys (PK) from the manufacturer's defaults. Select No to load the platform keys from a file. The options are Yes and No.

#### **Provision Factory Default Keys**

Select Enabled to install the default Secure-Boot keys set by the manufacturer. The options are Disabled and Enabled.

### ▶ Key Exchange Keys

Options include Details, Export, Update, Append, and Delete.

#### **Set New Key**

Select Yes to load the KEK from the manufacturer's defaults. Select No to load the KEK from a file. The options are Yes and No.

**Append Key**

Select Yes to add the KEK from the manufacturer's defaults list to the existing KEK. Select No to load the KEK from a file. The options are Yes and No.

**▶ Authorized Signatures**

Options include Details, Export, Update, Append, and Delete.

**Set New Key**

Select Yes to load the database from the manufacturer's defaults. Select No to load the DB from a file. The options are Yes and No.

**Append Key**

Select Yes to add the database from the manufacturer's defaults to the existing DB. Select No to load the DB from a file. The options are Yes and No.

**▶ Forbidden Signatures**

Options include Details, Export, Update, Append, and Delete.

**Set New Key**

Select Yes to load the DBX from the manufacturer's defaults. Select No to load the DBX from a file. The options are Yes and No.

**Append Key**

Select Yes to add the DBX from the manufacturer's defaults to the existing DBX. Select No to load the DBX from a file. The options are Yes and No.

**▶ Authorized TimeStamps**

Options include Details, Export, Update, Append, and Delete.

**Set New Key**

Select Yes to load the DBT from the manufacturer's defaults. Select No to load the DBT from a file. The options are Yes and No.

**Append Key**

Select Yes to add the DBT from the manufacturer's defaults list to the existing DBT. Select No to load the DBT from a file. The options are Yes and No.

**▶ OsRecovery Signature**

Options include Details, Export, Update, Append, and Delete.

This item uploads and installs an OSRecovery Signature. You may select options for Set New for a factory default key, or select Append to get it from a file. The file formats accepted are:

- 1) Public Key Certificate
  - a. EFI Signature List
  - b. EFI CERT X509 (DER Encoded)
  - c. EFI CERT RSA2048 (bin)
  - d. EFI SERT SHA256 (bin)
- 2) EFI Time Based Authenticated Variable

When prompted, select "Yes" to load Factory Defaults or "No" to load from a file.

## 4.7 Boot

Use this tab to configure Boot Settings:

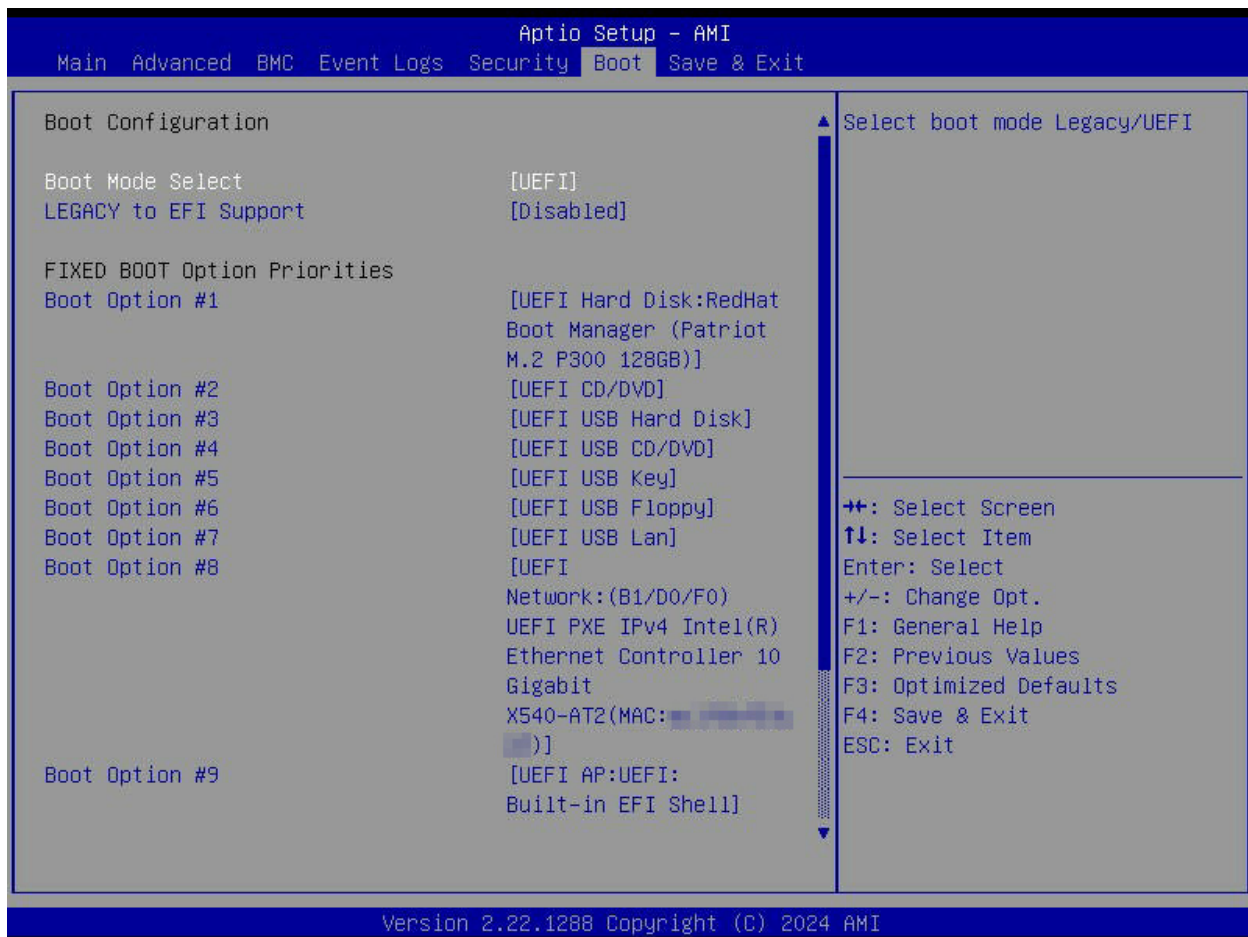

### Boot Mode Select

Use this item to select the type of device that the system is going to boot from. The options are Legacy, UEFI, and **Dual**.

### LEGACY to EFI Support

This option **Disables** or Enables the system to boot to an EFI OS after the boot failed from the legacy boot order.

### FIXED BOOT Option Priorities

This option prioritizes the order of bootable devices that the system to boot from. Press the <Enter> key on each entry from top to bottom to select devices.

### ►Delete Boot Option

Use this feature to remove a pre-defined boot device from which the system will boot during startup. The settings are [**Select one to Delete**] and UEFI: Built-in EFI Shell.

**► UEFI Application Boot Priorities**

This feature allows the user to specify which UEFI devices are boot devices.

- Boot Option #1 The settings include **UEFI: Built-in EFI Shell** and Disabled.

**► UEFI NETWORK Drive BBS Priorities**

This feature allows the user to specify which UEFI network drive devices are boot devices.

## 4.8 Save & Exit

Select the Save & Exit tab to enter the Save & Exit BIOS Setup screen.

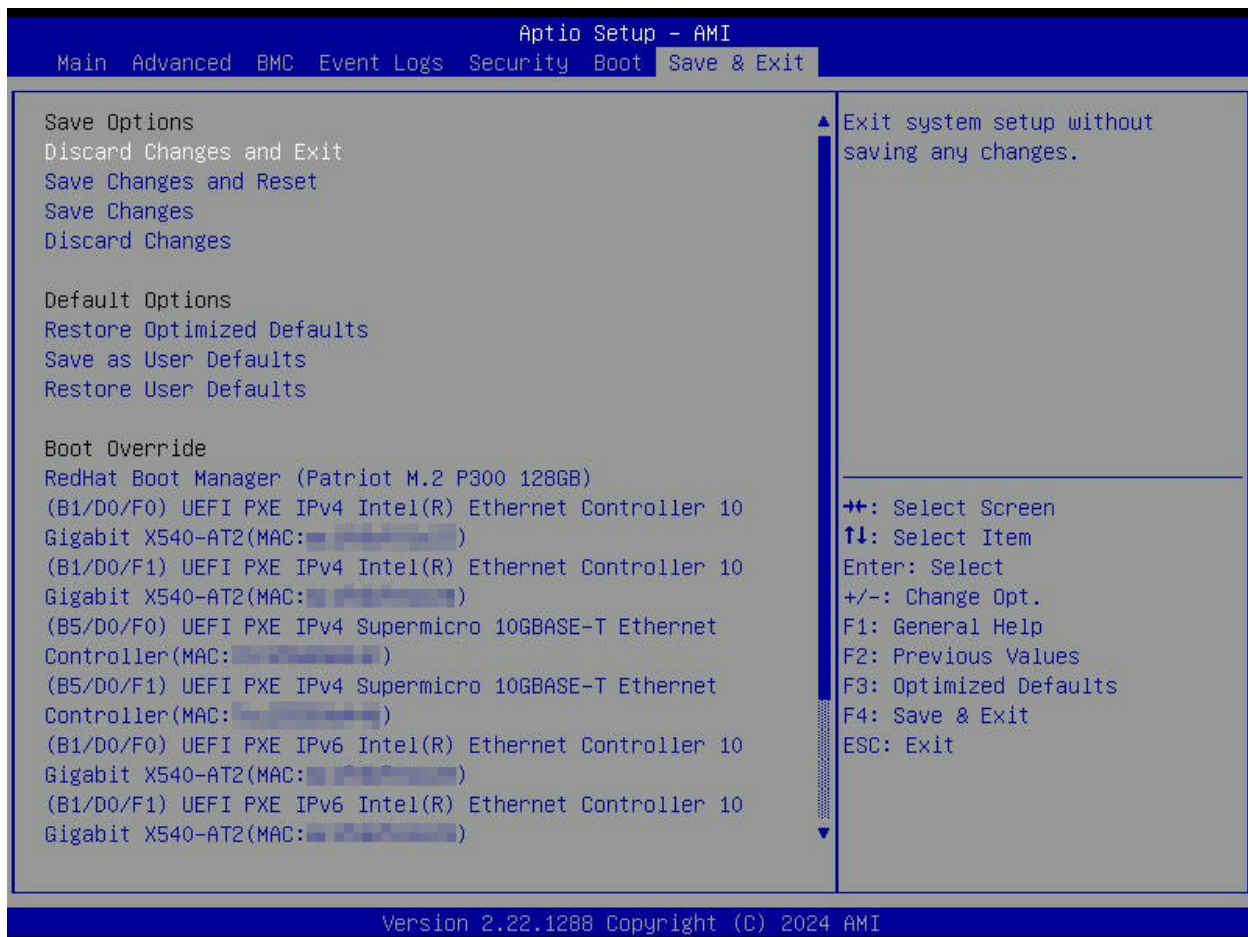

### Save Options

#### Discard Changes and Exit

Select this option to quit the BIOS Setup without making any permanent changes to the system configuration, and reboot the computer. Select Discard Changes and Exit from the Exit menu and press the <Enter> key.

#### Save Changes and Reset

Select this option to reset the system after saving the changes.

#### Save Changes

After completing the system configuration changes, select this option to save the changes you have made. This will not reset (reboot) the system.

**Discard Changes**

Select this option and press the <Enter> key to discard all the changes and return to the AMI BIOS utility Program.

**Default Options****Restore Defaults**

To set this feature, select Restore Defaults from the Save & Exit menu and press the <Enter> key. These are factory settings designed for maximum system stability, but not for maximum performance.

**Save as User Defaults**

To set this feature, select Save as User Defaults from the Exit menu and press the <Enter> key. This enables the user to save any changes to the BIOS setup for future use.

**Restore User Defaults**

To set this feature, select Restore User Defaults from the Exit menu and press the <Enter> key. Use this feature to retrieve user-defined settings that were saved previously.

**Boot Override Section**

Listed in this section are other boot options for the system (i.e., UEFI: Built-in EFI Shell). Select an option and press the <Enter> key. Your system will boot to the selected boot option.

# Appendix A

## Software

After the hardware has been installed, you can install the Operating System (OS), configure RAID settings and install the drivers.

### A.1 Microsoft Windows OS Installation

If you will be using RAID, you must configure RAID settings before installing the Windows OS and the RAID driver. Refer to the RAID Configuration User Guides posted on our website at [www.supernmicro.com/support/manuals](http://www.supernmicro.com/support/manuals).

#### *Installing the OS*

1. Create a method to access the MS Windows installation ISO file. That can be USB flash or media drive.
2. Go to the Supermicro web page for your motherboard and click on "Download the Latest Drivers and Utilities", select the proper driver, and copy it to a USB flash or media drive.
3. Boot from a bootable device with Windows OS installation. You can see a bootable device list by pressing **<F11>** during the system startup.

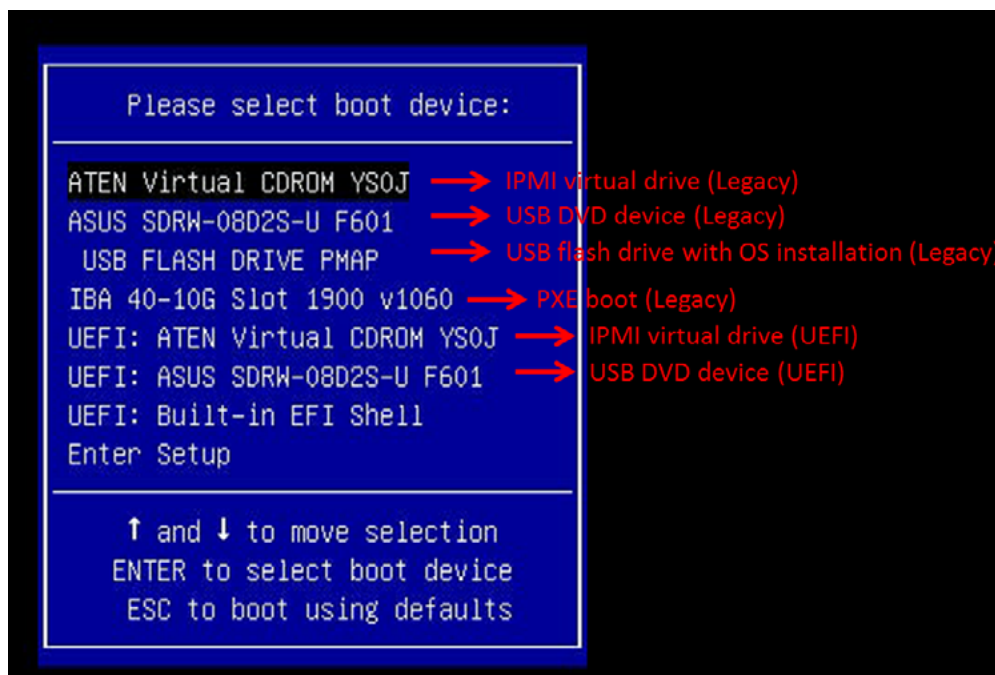
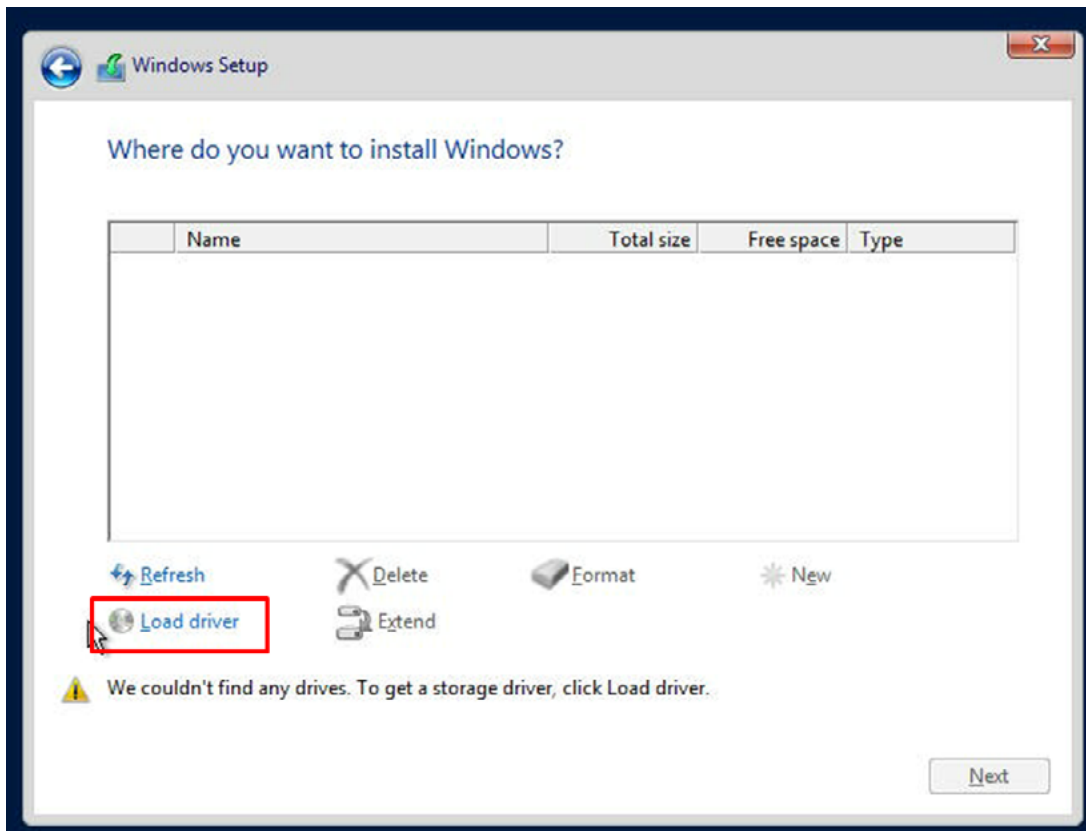

Figure A-1. Select Boot Device

4. During Windows Setup, continue to the dialog where you select the drives on which to install Windows. If the drive you want to use is not listed, click on “Load driver” link at the bottom left corner.



**Figure A-2. Load Driver Link**

To load the driver, browse the USB flash or media drive for the proper driver files.

- For RAID, choose the RAID driver indicated then choose the storage drive on which you want to install it.
  - For non-RAID, choose the AHCI driver indicated then choose the storage drive on which you want to install it.
5. Once all devices are specified, continue with the installation.
  6. After the Windows OS installation has completed, the system will automatically reboot multiple times.

## A.2 Driver Installation

The Supermicro website contains drivers and utilities for your system at <https://www.supermicro.com/wdl/>. Some of these must be installed, such as the chipset driver.

After accessing the website, go into the CDR\_Images (in the parent directory of the above link) and locate the ISO file for your motherboard. Download this file to a USB flash or media drive. (You may also use a utility to extract the ISO file if preferred.)

Another option is to go to the Supermicro website at <http://www.supermicro.com/products/>. Find the product page for your motherboard, and "Download the Latest Drivers and Utilities." Insert the flash or media drive and the screenshot shown below should appear.

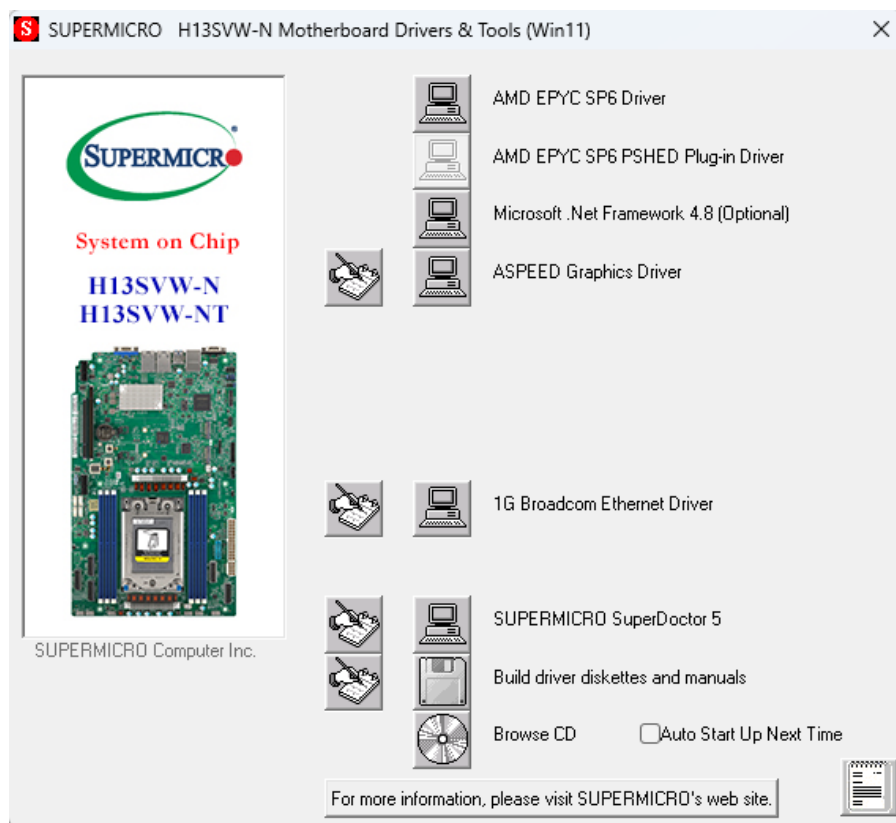

**Figure A-3. Driver & Tool Installation Screen**

**Note:** Click the icons showing a hand writing on paper to view the readme files for each item. Click the computer icons to the right of these items to install each item (from top to the bottom) one at a time. **After installing each item, you must re-boot the system before moving on to the next item on the list.** The bottom icon with a CD on it allows you to view the entire contents.

## A.3 SuperDoctor® 5

The Supermicro SuperDoctor 5 is a program that functions in a command-line or web-based interface for Windows and Linux operating systems. The program monitors such system health information as CPU temperature, system voltages, system power consumption, fan speed, and provides alerts via email or Simple Network Management Protocol (SNMP).

SuperDoctor 5 comes in local and remote management versions and can be used with Nagios to maximize your system monitoring needs. With SuperDoctor 5 Management Server (SSM Server), you can remotely control power on/off and reset chassis intrusion for multiple systems with SuperDoctor 5 or IPMI. SuperDoctor 5 Management Server monitors HTTP, FTP, and SMTP services to optimize the efficiency of your operation.

[SuperDoctor® Manual and Resources](#)



Figure A-4. SuperDoctor 5 Interface Display Screen (Health Information)

## A.4 IPMI

The H13SVW-NT-OS2 supports the Intelligent Platform Management Interface (IPMI). IPMI is used to provide remote access, monitoring and management. There are several BIOS settings that are related to IPMI.

Supermicro ships standard products with a unique password for the BMC ADMIN user. This password can be found on a label on the motherboard.

For general documentation and information on IPMI, please visit our website at: <http://www.supermicro.com/products/nfo/IPMI.cfm>.

## Appendix B

### Standardized Warning Statements

The following statements are industry standard warnings, provided to warn the user of situations which have the potential for bodily injury. Should you have questions or experience difficulty, contact Supermicro's Technical Support department for assistance. Only certified technicians should attempt to install or configure components.

Read this section in its entirety before installing or configuring components.

These warnings may also be found on our website at [http://www.supermicro.com/about/policies/safety\\_information.cfm](http://www.supermicro.com/about/policies/safety_information.cfm).

#### B.1 Battery Handling



**CAUTION:** There is risk of explosion if the battery is replaced by an incorrect type. Replace the battery only with the same or equivalent type recommended by the manufacturer. Dispose of used batteries according to the manufacturer's instructions

##### 電池の取り扱い

バッテリーを間違ったタイプに交換すると爆発の危険があります。交換する電池はメーカーが推奨する型、または同等のものを使用下さい。使用済電池は製造元の指示に従って処分して下さい。

##### 警告

如果更换的电池类型不正确，则存在爆炸危险。请只使用同类电池或制造商推荐的功能相当的电池更换原有电池。请按制造商的说明处理废旧电池。

##### 警告

如果更換的電池類型不正確，則有爆炸危險。請使用製造商建議之相同或功能相當的電池更換原有電池。請按照製造商的說明指示處理廢棄舊電池。

##### WARNUNG

Es besteht Explosionsgefahr, wenn die Batterie durch einen falschen Typ ersetzt wird. Ersetzen Sie die Batterie nur durch den gleichen oder vom Hersteller empfohlenen Batterietyp. Entsorgen Sie die benutzten Batterien nach den Anweisungen des Herstellers.

##### ATTENTION

Il existe un risque d'explosion si la batterie est remplacée par un type incorrect. Ne la remplacer que par une pile de type semblable ou équivalent, recommandée par le fabricant. Jeter les piles usagées conformément aux instructions du fabricant.

**ADVERTENCIA**

Existe riesgo de explosión si la batería se reemplaza por un tipo incorrecto. Reemplazar la batería exclusivamente con el mismo tipo o el equivalente recomendado por el fabricante. Desechar las baterías gastadas según las instrucciones del fabricante.

אזהרה!

קיימת סכנת פיצוץ אם הסוללה תוחלף בסוג שגוי. יש להחליף את הסוללה בסוג התואם מחברת יצרן מומלצת. סילוק הסוללות המשומשות יש לבצע לפי הוראות היצרן.

هناك خطر الانفجار إذا تم استبدال البطارية بنوع غير صحيح.

استبدال البطارية

فقط بنفس النوع أو ما يعادلها مما أوصت به الشركة المصنعة  
جخلص من البطاريات المسحمة وفقاً لتعليمات الشركة الصانعة

경고!

배터리를 잘못된 종류로 교체하면 폭발의 위험이 있습니다. 기존 배터리와 동일하거나 제조사에서 권장하는 동등한 종류의 배터리로만 교체해야 합니다. 제조사의 안내에 따라 사용된 배터리를 처리하여 주십시오.

**WAARSCHUWING**

Er bestaat explosiegevaar als de batterij wordt vervangen door een verkeerd type. Vervang de batterij slechts met hetzelfde of een equivalent type die door de fabrikant aanbevolen wordt. Gebruikte batterijen dienen overeenkomstig fabrieksvoorschriften afgevoerd te worden.

## B.2 Product Disposal



**Warning!** Ultimate disposal of this product should be handled according to all national laws and regulations.

### 製品の廃棄

この製品を廃棄処分する場合、国の関係する全ての法律・条例に従い処理する必要があります。

### 警告

本产品的废弃处理应根据所有国家的法律和规章进行。

### 警告

本產品的廢棄處理應根據所有國家的法律和規章進行。

### Warnung

Die Entsorgung dieses Produkts sollte gemäß allen Bestimmungen und Gesetzen des Landes erfolgen.

### ¡Advertencia!

Al deshacerse por completo de este producto debe seguir todas las leyes y reglamentos nacionales.

### Attention

La mise au rebut ou le recyclage de ce produit sont généralement soumis à des lois et/ou directives de respect de l'environnement. Renseignez-vous auprès de l'organisme compétent.

סילוק המוצר

אזהרה!

סילוק סופי של מוצר זה חייב להיות בהתאם להנחיות וחוקי המדינה.

التخلص النهائي من هذا المنتج ينبغي التعامل معه وفقا لجميع القوانين واللوائح الوطنية عند

### 경고!

이 제품은 해당 국가의 관련 법규 및 규정에 따라 폐기되어야 합니다.

### Waarschuwing

De uiteindelijke verwijdering van dit product dient te geschieden in overeenstemming met alle nationale wetten en reglementen.

## Appendix C

# UEFI BIOS Recovery

**Warning:** Do not upgrade the BIOS unless your system has a BIOS-related issue. Flashing the wrong BIOS can cause irreparable damage to the system. In no event shall Supermicro be liable for direct, indirect, special, incidental, or consequential damages arising from a BIOS update. If you need to update the BIOS, do not shut down or reset the system while the BIOS is updating. Doing so may cause a boot failure.

### C.1 Overview

The Unified Extensible Firmware Interface (UEFI) provides a software-based interface between the operating system and the platform firmware in the pre-boot environment. The UEFI specification supports an architecture-independent mechanism for add-on card initialization to allow the UEFI OS loader, which is stored in the add-on card, to boot the system. The UEFI offers clean, hands-off control to a computer system at bootup.

### C.2 Recovering the UEFI BIOS Image

A UEFI BIOS flash chip consists of a recovery BIOS block and a main BIOS block (a main BIOS image). The boot block contains critical BIOS codes, including memory detection and recovery codes for the user to flash a new BIOS image if the original main BIOS image is corrupted. When the system power is on, the boot block codes execute first. Once it is completed, the main BIOS code will continue with system initialization and bootup.

### C.3 Recovering the BIOS Block with a USB Device

If the BIOS file is corrupted and the system is not able to boot up, this feature will allow you to recover the BIOS image using a USB-attached device. A USB flash or media drive can be used for this purpose. Please note that a USB hard disk drive is NOT supported. Follow the procedures on the next page to recover the BIOS.

1. Using a different machine, copy the "Super.ROM" binary image file into the disc Root "\\" directory of a USB flash or media drive with FAT16 or FAT32 format and rename the file to SUPER.ROM.

**Note:** If you cannot locate the "SUPER.ROM" file in your driver disk, visit our website at [www.supermicro.com](http://www.supermicro.com) to download the correct BIOS image into a USB flash device and rename it "SUPER.ROM".

2. While the system is turned off, insert the USB device that contains the new BIOS binary image (SUPER.ROM).
3. Power on the system.
4. After the system is turned on, the system will enter the BIOS Recovery menu. Select "Proceed with flash update" to start the BIOS recovery process. **DO NOT INTERRUPT THIS PROCESS UNTIL IT FINISHED!**



5. After the Boot Sector Recovery Process is complete, press any key to reboot the system.

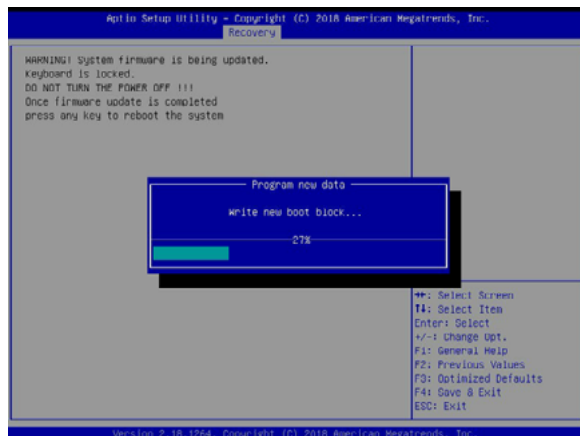
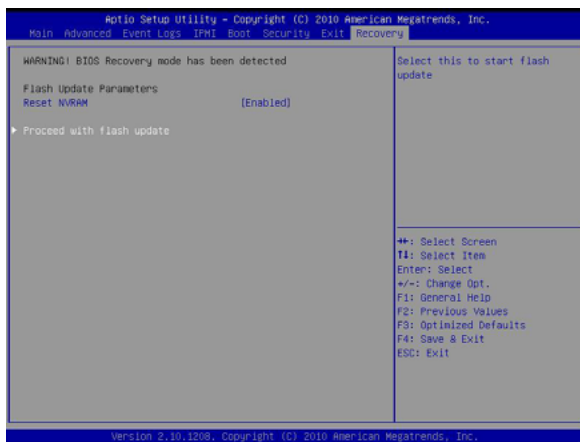

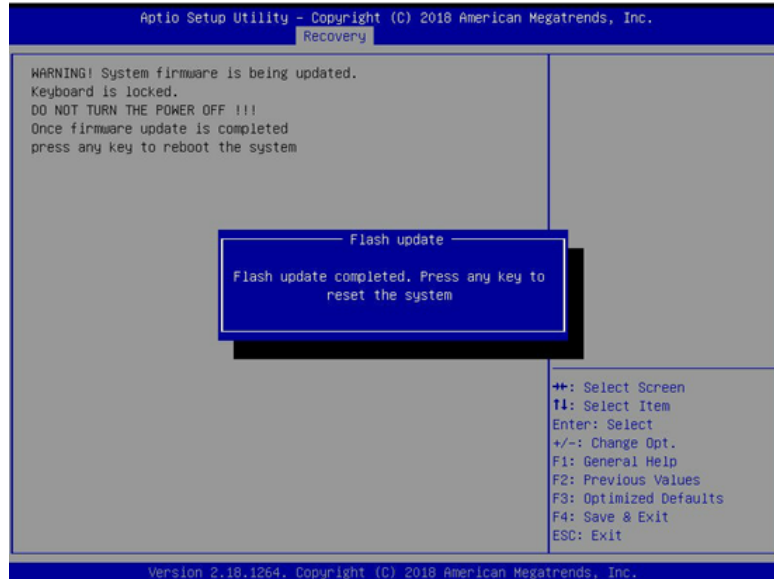
**Notes:**

- The BIOS recovery (SUPER.ROM) will not work if BIOS suffered a multi-block crash.
- If you have purchased an OOB license, you can do a BIOS flash again through BMC WebGUI or SUM. Please refer to these SUPERMICRO software-related videos:

Activate OOB license: [https://www.youtube.com/watch?v=V4spX\\_DOV7I](https://www.youtube.com/watch?v=V4spX_DOV7I)

SUPERMICO BIOS Update: <https://www.youtube.com/watch?v=S8z6iOEHGwY>

- If the BIOS flash recovery fails, contact our RMA Department to have the BIOS chip re-programmed. This will require shipping the board to Supermicro for repair.

Submit your RMA request at <https://www.supermicro.com/support/rma>

Please make sure to follow all instructions when returning the motherboard.