



H14SST-GE

USER'S MANUAL

Revision 1.0 (MNL-2855)

The information in this User's Manual has been carefully reviewed and is believed to be accurate. The vendor assumes no responsibility for any inaccuracies that may be contained in this document, and makes no commitment to update or to keep current the information in this manual, or to notify any person or organization of the updates. Note: For the most up-to-date version of this manual, see our website at <https://www.supermicro.com>.

Super Micro Computer, Inc. ("Supermicro") reserves the right to make changes to the product described in this manual at any time and without notice. This product, including software and documentation, is the property of Supermicro and/or its licensors, and is supplied only under a license. Any use or reproduction of this product is not allowed, except as expressly permitted by the terms of said license.

IN NO EVENT WILL Super Micro Computer, Inc. BE LIABLE FOR DIRECT, INDIRECT, SPECIAL, INCIDENTAL, SPECULATIVE OR CONSEQUENTIAL DAMAGES ARISING FROM THE USE OR INABILITY TO USE THIS PRODUCT OR DOCUMENTATION, EVEN IF ADVISED OF THE POSSIBILITY OF SUCH DAMAGES. IN PARTICULAR, SUPER MICRO COMPUTER, INC. SHALL NOT HAVE LIABILITY FOR ANY HARDWARE, SOFTWARE, OR DATA STORED OR USED WITH THE PRODUCT, INCLUDING THE COSTS OF REPAIRING, REPLACING, INTEGRATING, INSTALLING OR RECOVERING SUCH HARDWARE, SOFTWARE, OR DATA.

Any disputes arising between manufacturer and customer shall be governed by the laws of Santa Clara County in the State of California, USA. The State of California, County of Santa Clara shall be the exclusive venue for the resolution of any such disputes. Supermicro's total liability for all claims will not exceed the price paid for the hardware product.

FCC Statement: This equipment has been tested and found to comply with the limits for a Class A or Class B digital device pursuant to Part 15 of the FCC Rules. These limits are designed to provide reasonable protection against harmful interference when the equipment is operated in industrial environment for Class A device or in residential environment for Class B device. This equipment generates, uses, and can radiate radio frequency energy and, if not installed and used in accordance with the manufacturer's instruction manual, may cause harmful interference with radio communications. Operation of this equipment in a residential area is likely to cause harmful interference, in which case you will be required to correct the interference at your own expense.

California Best Management Practices Regulations for Perchlorate Materials: This Perchlorate warning applies only to products containing CR (Manganese Dioxide) Lithium coin cells. "Perchlorate Material-special handling may apply. See <https://www.dtsc.ca.gov/hazardouswaste/perchlorate>".



WARNING: This product can expose you to chemicals including lead, known to the State of California to cause cancer and birth defects or other reproductive harm. For more information, go to <https://www.P65Warnings.ca.gov>.



AVERTISSEMENT : Ce produit peut vous exposer à des agents chimiques, y compris le plomb, identifié par l'État de Californie comme pouvant causer le cancer, des malformations congénitales ou d'autres troubles de la reproduction. Pour de plus amples informations, prière de consulter <https://www.P65Warnings.ca.gov>.

The products sold by Supermicro are not intended for and will not be used in life support systems, medical equipment, nuclear facilities or systems, aircraft, aircraft devices, aircraft/emergency communication devices or other critical systems whose failure to perform be reasonably expected to result in significant injury or loss of life or catastrophic property damage. Accordingly, Supermicro disclaims any and all liability, and should buyer use or sell such products for use in such ultra-hazardous applications, it does so entirely at its own risk. Furthermore, buyer agrees to fully indemnify, defend and hold Supermicro harmless for and against any and all claims, demands, actions, litigation, and proceedings of any kind arising out of or related to such ultra-hazardous use or sale.

Manual Revision 1.0

Release Date: September 08, 2025

Unless you request and receive written permission from Super Micro Computer, Inc., you may not copy any part of this document. Information in this document is subject to change without notice. Other products and companies referred to herein are trademarks or registered trademarks of their respective companies or mark holders.

Copyright © 2025 by Super Micro Computer, Inc.  
All rights reserved.

**Published in the United States of America**

# Preface

## About This Manual

This manual is written for professional system integrators and PC technicians. It provides information for the installation and use of the H14SST-GE motherboard. Installation and maintenance should be performed by certified service technicians only.

## Notes

For your system to work properly, follow the links below to download all necessary drivers/utilities and the user's manual for your motherboard.

- Supermicro product manuals: <https://www.supermicro.com/support/manuals>
- Product drivers and utilities: <https://www.supermicro.com/wdl>
- Product safety info: [https://www.supermicro.com/about/policies/safety\\_information.cfm](https://www.supermicro.com/about/policies/safety_information.cfm)
- A secure data deletion tool designed to fully erase all data from storage devices can be found on our website:  
[https://www.supermicro.com/about/policies/disclaimer.cfm?url=/wdl/utility/Lot9\\_Secure\\_Data\\_Deletion\\_Utility](https://www.supermicro.com/about/policies/disclaimer.cfm?url=/wdl/utility/Lot9_Secure_Data_Deletion_Utility)
- Frequently Asked Questions: <https://www.supermicro.com/FAQ/index.php>
- If you still have questions after referring to our FAQs, contact our support team. Region-specific Technical Support email addresses can be found at: "[Contacting Supermicro](#)" on page 9
- If you have any feedback on Supermicro product manuals, contact our writing team at: [Techwriterteam@supermicro.com](mailto:Techwriterteam@supermicro.com)

This manual may be periodically updated without notice. Check the Supermicro website for possible updates to the manual revision level.

## Conventions Used in the Manual

Special attention should be given to the following symbols for proper installation and to prevent damage done to the components or injury to yourself.



**Warning!** Indicates important information given to prevent equipment/property damage or personal injury.



**Warning!** Indicates high voltage may be encountered while performing a procedure.

**Important:** Important information given to ensure proper motherboard installation or to relay safety precautions.

**Note:** Additional information given to differentiate various models or to provide information for proper motherboard setup.

# Contents

<b>Contacting Supermicro</b> .....	<b>9</b>
<b>Chapter 1: Introduction</b> .....	<b>10</b>
1.1 Quick Reference .....	11
Motherboard Layout .....	11
Quick Reference Table .....	13
Motherboard Features .....	14
Motherboard Block Diagram .....	16
1.2 Platform Overview .....	17
1.3 System Health Monitoring .....	18
Onboard Voltage Monitors .....	18
Fan Status Monitor with Firmware Control .....	18
Environmental Temperature Control .....	18
1.4 ACPI Features .....	19
<b>Chapter 2: Component Installation</b> .....	<b>20</b>
2.1 Static-Sensitive Devices .....	21
Precautions .....	21
Unpacking .....	21
2.2 Motherboard Installation .....	22
Installing the Motherboard .....	22
2.3 Processor and Heatsink Installation .....	24
Preparing the Processor Socket .....	24
Installing the Processor into the Frame .....	26
Installing the Heatsink .....	29
Uninstalling the Heatsink and Processor .....	30
2.4 Memory Support and Installation .....	32
Memory Support .....	32
General Guidelines for Optimizing Memory Performance .....	33
DIMM Installation .....	33
DIMM Removal .....	35
2.5 Battery Removal and Installation .....	37
Battery Removal .....	37

Proper Battery Disposal .....	37
Battery Installation .....	37
2.6 Connections, Jumpers, and LEDs .....	38
Power Supply and Power Connections .....	38
Power Supply .....	38
Power Connectors .....	38
Headers and Connections .....	38
AIOM Sideband Signal Header .....	38
M.2 M-Key PCIe 5.0 x4 Slots .....	39
MCIO PCIe 5.0 x8 Connectors .....	39
NC-SI Connection .....	39
TPM/Port 80 Header .....	39
Jumper Settings .....	40
CMOS Clear .....	40
LED Indicators .....	41
BMC Heartbeat LED .....	41
Onboard Power LED .....	41
Unit ID (UID) LED .....	42
<b>Chapter 3: Troubleshooting .....</b>	<b>43</b>
3.1 Troubleshooting Procedures .....	44
Before Power On .....	44
No Power .....	44
No Video .....	44
System Boot Failure .....	44
Memory Errors .....	45
Losing the System's Setup Configuration .....	45
If the System Becomes Unstable .....	45
3.2 Technical Support Procedures .....	47
3.3 Motherboard Battery .....	48
3.4 Where to Get Replacement Components .....	49
3.5 Returning Merchandise for Service .....	50
3.6 Feedback .....	51
<b>Chapter 4: UEFI BIOS .....</b>	<b>52</b>
4.1 Introduction .....	53

---

---

Updating BIOS .....	53
Starting the Setup Utility .....	53
4.2 Main Setup .....	55
4.3 Advanced Setup Configurations .....	57
Boot Feature Menu .....	57
CPU Configuration Menu .....	59
NB Configuration .....	61
Trusted Computing Menu .....	64
ACPI Settings Menu .....	64
Super IO Configuration Menu .....	65
Serial Port 2 Configuration Menu .....	65
Serial Port Console Redirection Menu .....	65
PCIe/PCI/PnP Configuration Menu .....	68
USB Configuration .....	70
Network Configuration Menu .....	70
SATA Configuration Menu .....	73
HTTP Boot Configuration Menu .....	74
Supermicro KMS Server Configuration Menu .....	75
Super-Guardians Configuration Menu .....	77
System Diagnostics Configuration .....	79
TLS Authenticate Configuration Menu .....	79
Driver Health Menu .....	79
4.4 BMC .....	80
System Event Log Menu .....	80
BMC Network Configuration Menu .....	81
4.5 Event Logs .....	84
4.6 Security .....	86
4.7 Boot .....	91
4.8 Save & Exit .....	93
<b>Appendix A: Software .....</b>	<b>95</b>
Microsoft Windows OS Installation .....	95
Installing the OS .....	95
Driver Installation .....	97
BMC .....	98

BMC ADMIN User Password .....	99
<b>Appendix B: Standardized Warning Statements .....</b>	<b>100</b>
Battery Handling .....	100
Product Disposal .....	102

---

---

## Contacting Supermicro

### Headquarters

Address: Super Micro Computer, Inc.  
980 Rock Ave.  
San Jose, CA 95131 U.S.A.

Tel: +1 (408) 503-8000

Fax: +1 (408) 503-8008

Email: [Marketing@supermicro.com](mailto:Marketing@supermicro.com) (General Information)  
[Sales-USA@supermicro.com](mailto:Sales-USA@supermicro.com) (Sales Inquiries)  
[Government\\_Sales-USA@supermicro.com](mailto:Government_Sales-USA@supermicro.com) (Gov. Sales Inquiries)  
[Support@supermicro.com](mailto:Support@supermicro.com) (Technical Support)  
[RMA@Supermicro.com](mailto:RMA@Supermicro.com) (RMA Support)  
[Webmaster@supermicro.com](mailto:Webmaster@supermicro.com) (Webmaster)

Website: <https://www.supermicro.com>

### Europe

Address: Super Micro Computer B.V.  
Het Sterrenbeeld 28, 5215 ML  
's-Hertogenbosch, The Netherlands

Tel: +31 (0) 73-6400390

Fax: +31 (0) 73-6416525

Email: [Sales\\_Europe@supermicro.com](mailto:Sales_Europe@supermicro.com) (Sales Inquiries)  
[Support\\_Europe@supermicro.com](mailto:Support_Europe@supermicro.com) (Technical Support)  
[RMA\\_Europe@supermicro.com](mailto:RMA_Europe@supermicro.com) (RMA Support)

Website: <https://www.supermicro.nl>

### Asia-Pacific

Address: Super Micro Computer, Inc.  
3F, No. 150, Jian 1st Rd.  
Zhonghe Dist., New Taipei City 235 Taiwan (R.O.C)

Tel: +886 (2) 8226-3990

Fax: +886 (2) 8226-3992

Email: [Sales-Asia@supermicro.com.tw](mailto:Sales-Asia@supermicro.com.tw) (Sales Inquiries)  
[Support@supermicro.com.tw](mailto:Support@supermicro.com.tw) (Technical Support)  
[RMA@supermicro.com.tw](mailto:RMA@supermicro.com.tw) (RMA Support)

Website: <https://www.supermicro.com.tw>

# Chapter 1:

## Introduction

Congratulations on purchasing your computer motherboard from an industry leader. Supermicro motherboards are designed to provide you with the highest standards in quality and performance.

---

<b>1.1 Quick Reference</b> .....	<b>11</b>
Motherboard Layout .....	11
Quick Reference Table .....	13
Motherboard Features .....	14
Motherboard Block Diagram .....	16
<b>1.2 Platform Overview</b> .....	<b>17</b>
<b>1.3 System Health Monitoring</b> .....	<b>18</b>
Onboard Voltage Monitors .....	18
Fan Status Monitor with Firmware Control .....	18
Environmental Temperature Control .....	18
<b>1.4 ACPI Features</b> .....	<b>19</b>

## 1.1 Quick Reference

For details on the H14SST-GE motherboard layout, features, and other quick reference information, refer to the content below.

### Motherboard Layout

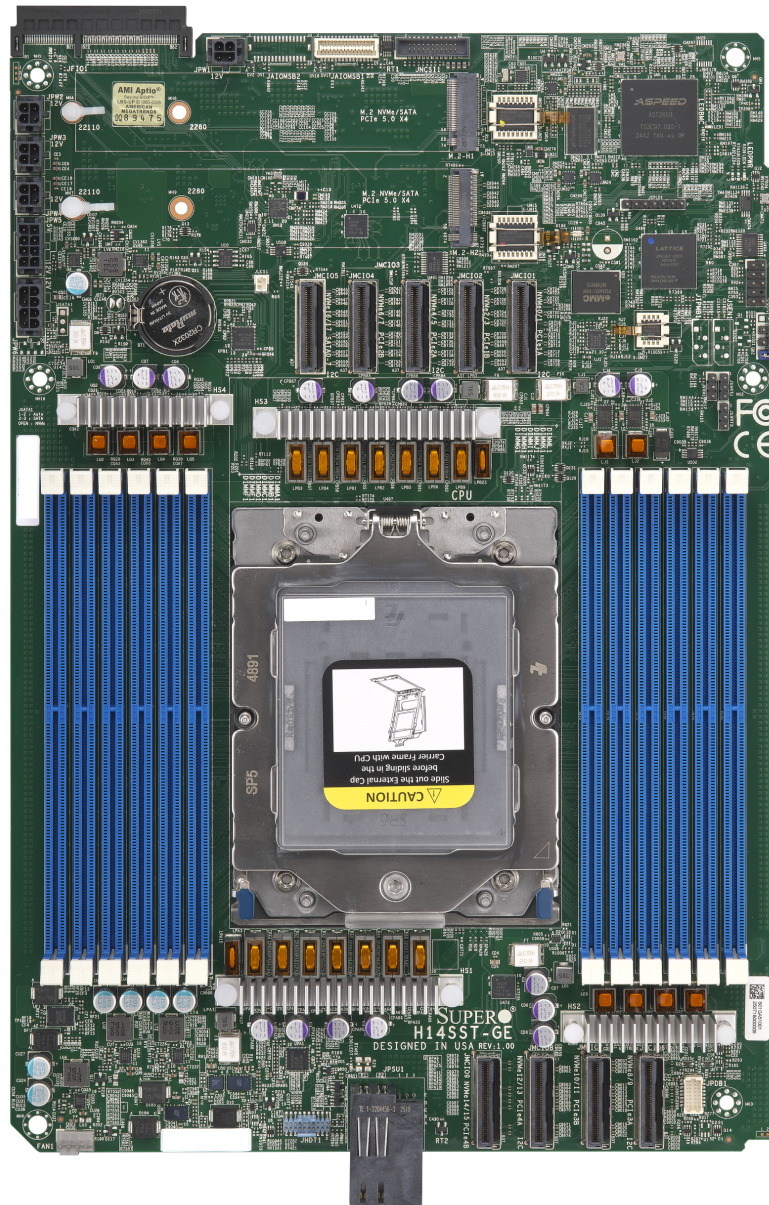

Figure 1-1. H14SST-GE Motherboard Photo

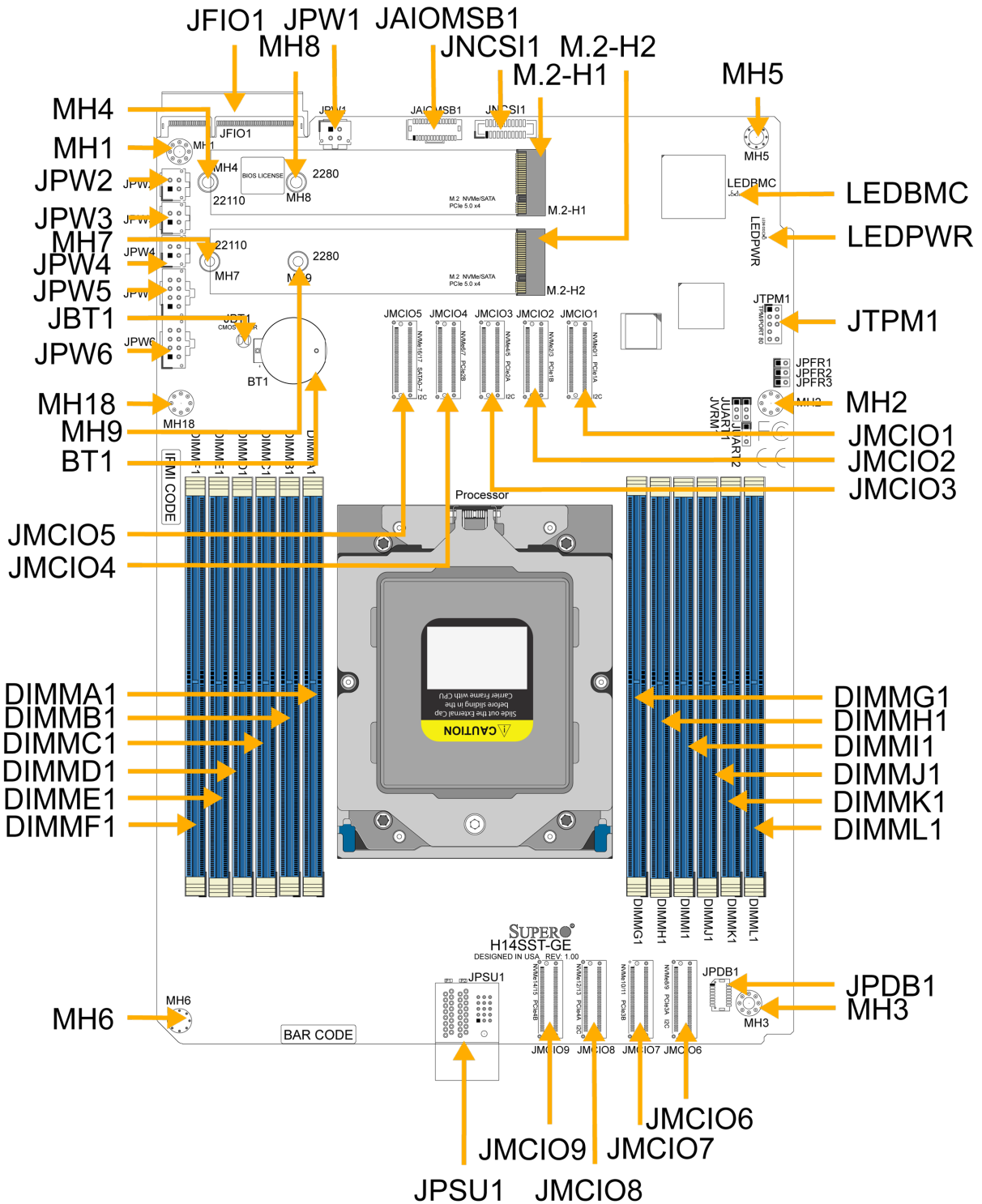

Figure 1-2. H14SST-GE Motherboard Layout

**Notes:**

- For detailed information on jumpers, connectors, and LED indicators, see "[Component Installation](#)" on page 20.
- "■" indicates the location of pin 1.
- "MH" indicates the location of a mounting hole.
- Components not documented are for internal testing purposes only.
- Use only the correct type of onboard CMOS battery as specified by the manufacturer. To avoid possible explosion, do not install the onboard battery upside down.

**Quick Reference Table**

Jumper	Description	Default Setting
JBT1	CMOS Clear	Open (Normal)

LED	Description	Status
LEDBMC	BMC Heartbeat LED	Green Blinking: BMC Normal Green Blinking Fast: BMC Initializing
LEDPWR	Onboard Power LED	Solid Green: Power On

Connector	Description
BT1	Onboard Battery
JAIOMSB1	Sideband Signal Header
JFIO1	Grand Twin Front IPMI and Onboard NIC Module Connector
JMCIO1–JMCIO4, JMCIO6–JMCIO9	MCIO PCIe 5.0 x8 Connectors
JMCIO5	MCIO PCIe 5.0/SATA3 x8 Connector
JNCSI1	NC-SI Connector
JPDB1	Sideband Connector to GPU PDB
JPSU1	Power Supply Module Connector
JPW1, JPW5, JPW6	8-pin +12 V/+5 V Power Connector for SATA Backplane

Connector	Description
JPW2–JPW4	4-pin +12 V Power Connectors for NVMe Backplane, AIOM Adapter and Internal PCIe Riser Card
JTPM1	Trusted Platform Module/Port 80 Connector
M.2-H1, M.2-H2	M.2 NVMe or SATA SSDs

**Note:** Jumpers, connectors, switches, and LED indicators that are not described in these tables are for manufacturing testing purposes only, and are not covered in this manual.

## Motherboard Features

Motherboard Features
<b>CPU</b>
<ul style="list-style-type: none"> <li>Single AMD EPYC™ 9005 Series processor processors in Socket SP5</li> </ul>
<b>Memory</b>
<ul style="list-style-type: none"> <li>Up to 3 TB registered ECC DDR5 memory with speeds of up to 6400 MT/s in 12 memory slots</li> </ul> <p><b>Note:</b> Memory speed support depends on the processor used in the system.</p>
<b>DIMM Size</b>
<ul style="list-style-type: none"> <li>Up to 256 GB</li> </ul>
<b>Chipset</b>
<ul style="list-style-type: none"> <li>System on Chip (SoC)</li> </ul>
<b>Expansion Slots</b>
<ul style="list-style-type: none"> <li>Two M.2 PCIe 5.0 x4 connectors in the 22110/2280 form factors</li> <li>One PCIe 4.0 x8 4C customized 124-pin SLIM COOL EDGE connector (for the I/O module)</li> </ul>
<b>Input/Output</b>
<ul style="list-style-type: none"> <li>Eight PCIe 5.0 x8 MCIO connectors</li> <li>One PCIe 5.0/SATA3 x8 MCIO hybrid port connector</li> </ul>
<b>Network</b>
<ul style="list-style-type: none"> <li>ATEN IPMI from ASPEED BMC for one Gigabit RJ45 port</li> <li>AIOM1/AIOM2 through cable to MCIO connectors</li> </ul>
<b>Graphics</b>
<ul style="list-style-type: none"> <li>Graphics controller through ASPEED AST2600 BMC</li> </ul>

<b>Motherboard Features</b>
<b>BIOS</b>
<ul style="list-style-type: none"> <li>• 512 Mb AMI BIOS® SPI Flash BIOS</li> <li>• ACPI 6.5, SMBIOS 3.7 or later, Plug-and-Play (PnP), Real Time Clock (RTC) wakeup, Riser Card Auto-Detection support</li> </ul>
<b>Power Management</b>
<ul style="list-style-type: none"> <li>• ACPI power management (S5)</li> <li>• Wake-on-LAN</li> <li>• Power-on mode for AC power recovery</li> </ul>
<b>System Health Monitoring</b>
<ul style="list-style-type: none"> <li>• Onboard voltage monitoring for +3.3 V, +5 V, +12 V, +3.3 VStby, +5 VStby, Vcore, CPU temperature, system temperature, peripheral temperature, memory temperature, and NVMe temperature</li> <li>• CPU thermal trip support</li> </ul>
<b>Fan Control</b>
<ul style="list-style-type: none"> <li>• Fan speed control</li> </ul>
<b>System Management</b>
<ul style="list-style-type: none"> <li>• Trusted Platform Module (TPM) support</li> <li>• SDO/SAA/SSM</li> </ul>
<b>LED Indicators</b>
<ul style="list-style-type: none"> <li>• BMC heartbeat LED</li> <li>• Power/suspend-state Indicator</li> <li>• UID/remote UID</li> </ul>
<b>Dimensions</b>
8.53" x 12.42" (216.7 mm x 315.5 mm) (W x L)

## Motherboard Block Diagram

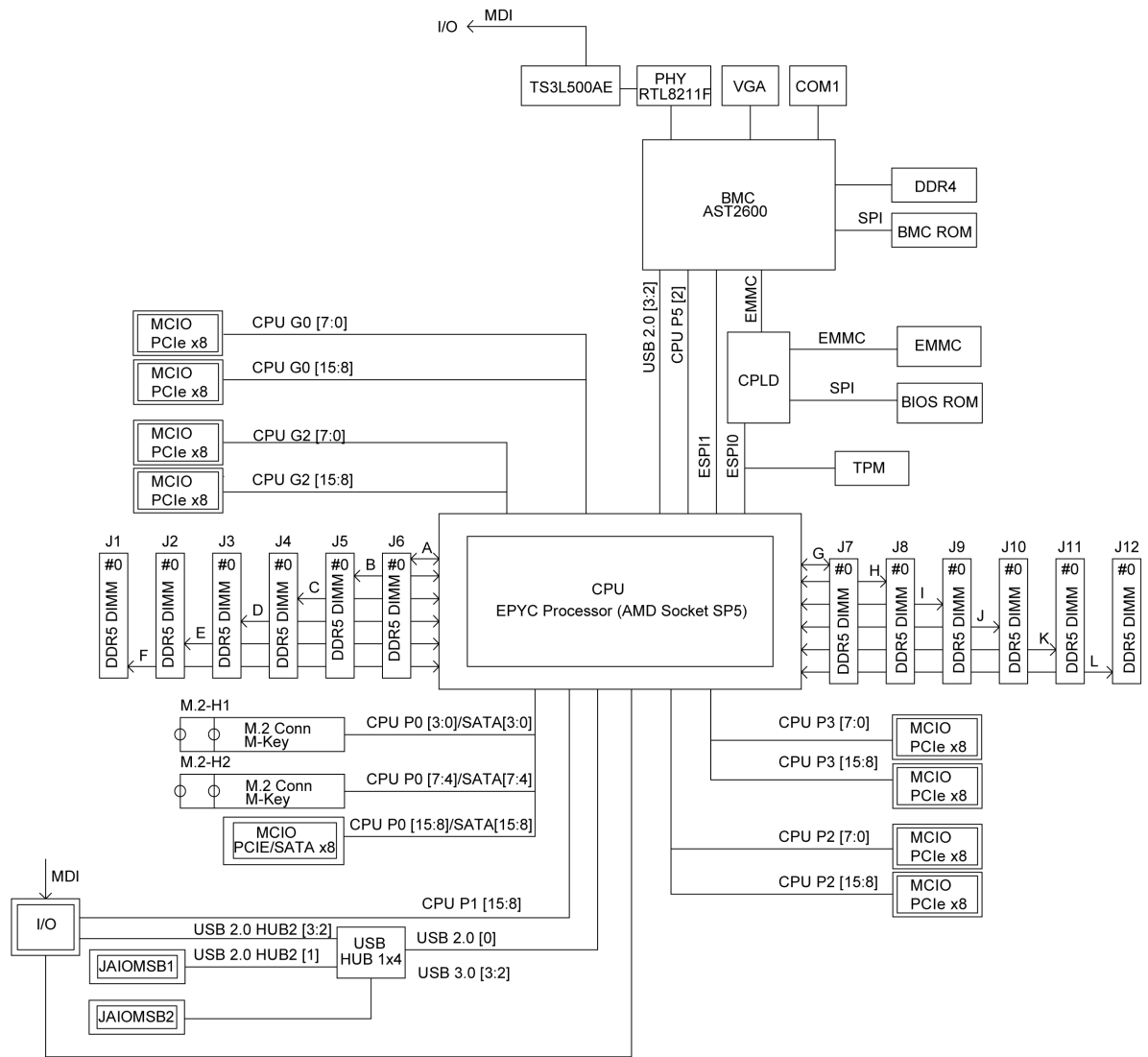

Figure 1-3. Motherboard Block Diagram

**Note:** This is a general block diagram and may not exactly represent the features on your motherboard. For the actual specifications of your motherboard, see the previous pages.

## 1.2 Platform Overview

Built upon the functionality and capability of the AMD EPYC™ 9005 Series processor in Socket SP5, the H14SST-GE motherboard offers maximum I/O expandability, energy efficiency, and data reliability in a 3 nm process architecture, and is optimized for embedded storage solutions, networking applications, or cloud-computing platforms.

With the support of new micro-architecture 3 nm process technology, it increases system performance for a multitude of server applications.

The following features are supported by the AMD EPYC™ 9005 Series processor:

- ACPI Power Management Logic Support Rev. 6.5
- Adaptive Thermal Management/Monitoring
- PCIe 5.0 with a transfer rate up to 32 GT/s and SATA 3.0 with a transfer rate of up to 6.0 Gb/s
- System Management Bus (SMBus) Specification Version 3.1.1

## 1.3 System Health Monitoring

### Onboard Voltage Monitors

An onboard voltage monitor will continuously scan the voltages of the onboard chipset, memory, processor, and battery. Once a voltage becomes unstable, a warning is given or an error message is sent to the screen. You can adjust the voltage thresholds to define the sensitivity of the voltage monitor. Real time voltage levels are displayed in IPMI.

### Fan Status Monitor with Firmware Control

The system health monitor embedded in the BMC chip can check the RPM status of the cooling fans. The processor and chassis fans are controlled via IPMI.

### Environmental Temperature Control

System Health sensors in the BMC monitor the temperatures and voltage settings of onboard processors and the system in real time via the IPMI interface. Whenever the temperature of the processor or the system exceeds a user-defined threshold, system/processor cooling fans will be turned on to prevent the processor or the system from overheating.

**Note:** To avoid possible system overheating, be sure to provide adequate airflow to your system.

## 1.4 ACPI Features

ACPI stands for Advanced Configuration and Power Interface. The ACPI specification defines a flexible and abstract hardware interface that provides a standard way to integrate power management features throughout a computer system, including its hardware, operating system and application software. This enables the system to automatically turn on and off peripherals such as network cards, hard disk drives, and printers.

In addition to enabling operating system-directed power management, ACPI also provides a generic system event mechanism for Plug and Play, an operating system-independent interface for configuration control. ACPI leverages the Plug and Play BIOS data structures while providing a processor architecture-independent implementation that is compatible with Windows Server 2025.

# Chapter 2:

## Component Installation

This chapter provides instructions on installing and replacing main system components for the H14SST-GE motherboard. To prevent compatibility issues, only use components that match the specifications and/or part numbers given.

Installation or replacement of most components require that power first be removed from the system. Follow the procedures given in each section.

---

<b>2.1 Static-Sensitive Devices</b> .....	<b>21</b>
Precautions .....	21
Unpacking .....	21
<b>2.2 Motherboard Installation</b> .....	<b>22</b>
Installing the Motherboard .....	22
<b>2.3 Processor and Heatsink Installation</b> .....	<b>24</b>
Preparing the Processor Socket .....	24
Installing the Processor into the Frame .....	26
Installing the Heatsink .....	29
Uninstalling the Heatsink and Processor .....	30
<b>2.4 Memory Support and Installation</b> .....	<b>32</b>
Memory Support .....	32
General Guidelines for Optimizing Memory Performance .....	33
DIMM Installation .....	33
DIMM Removal .....	35
<b>2.5 Battery Removal and Installation</b> .....	<b>37</b>
Battery Removal .....	37
Proper Battery Disposal .....	37
Battery Installation .....	37
<b>2.6 Connections, Jumpers, and LEDs</b> .....	<b>38</b>
Power Supply and Power Connections .....	38
Headers and Connections .....	38
Jumper Settings .....	40
LED Indicators .....	41

## 2.1 Static-Sensitive Devices

Electrostatic Discharge (ESD) can damage electronic components. To avoid damaging your motherboard, it is important to handle it very carefully. The following measures are generally sufficient to protect your equipment from ESD.

### Precautions

- Use a grounded wrist strap designed to prevent static discharge.
- Touch a grounded metal object before removing the board from the antistatic bag.
- Handle the motherboard only by its edges. Do not touch its components, peripheral chips, memory modules, or gold contacts.
- When handling chips or modules, avoid touching their pins.
- Put the motherboard and peripherals back into their antistatic bags when not in use.
- For grounding purposes, make sure that your computer chassis provides excellent conductivity between the power supply, the case, the mounting fasteners, and the motherboard.
- Use only the correct type of onboard CMOS battery. To avoid possible explosion, do not install the onboard battery upside down.

### Unpacking

To avoid static damage, the motherboard is shipped in antistatic packaging. When unpacking the motherboard, make sure that the person handling it is static protected.

## 2.2 Motherboard Installation

All motherboards have standard mounting holes to fit different types of chassis. Make sure that the locations of all the mounting holes for both the motherboard and the chassis match. Although a chassis may have both plastic and metal mounting fasteners, metal ones are highly recommended because they ground the motherboard to the chassis. Make sure that the metal standoffs click in or are screwed in tightly.

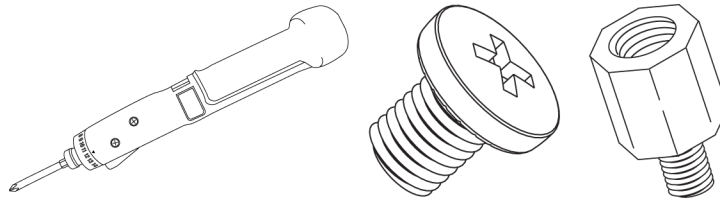

**Figure 2-1. Torque Driver (1), Philips Screws (6), and Standoffs (6, only if Needed)**

### Notes:

- To avoid damaging the motherboard and its components, do not use a force greater than 8 lbf-in on each mounting screw during motherboard installation.
- Some components are very close to the mounting holes. Take precautionary measures to avoid damaging these components when installing the motherboard to the chassis.

## Installing the Motherboard

1. Install the I/O shield into the back of the chassis, if applicable.

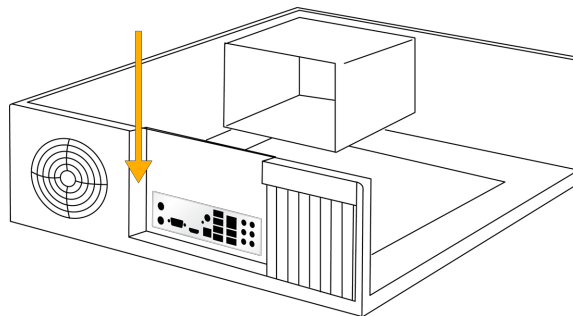

**Figure 2-2. Installing the I/O Shield**

**Note:** Images displayed are for illustration purposes only. The components installed in your system may or may not look exactly the same as the graphics shown in the manual.

2. Locate the mounting holes on the motherboard. See Motherboard Installation for the location.

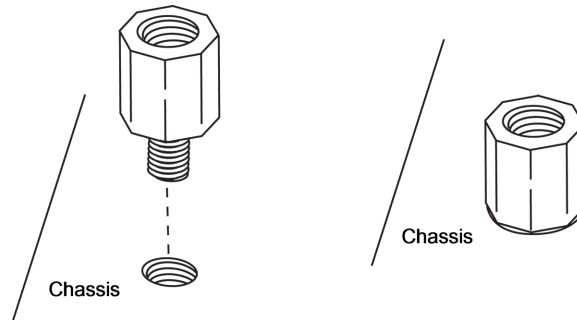

**Figure 2-3. Locating the Mounting Holes**

3. Locate the matching mounting holes on the chassis. Align the mounting holes on the motherboard against the mounting holes on the chassis.

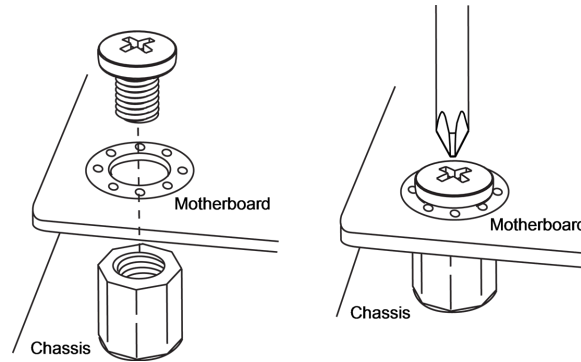

**Figure 2-4. Aligning the Mounting Holes**

4. Install standoffs in the chassis as needed.
5. Install the motherboard into the chassis carefully to avoid damaging other motherboard components.
6. Insert pan head #6 screws into the mounting holes on the motherboard and the matching mounting holes on the chassis.
7. Make sure that the motherboard is securely placed in the chassis.

## 2.3 Processor and Heatsink Installation

This section provides procedures to install the processor(s) and heatsink(s).

### Notes:

- Take industry standard precautions to avoid ESD damage. For details, see "[Static-Sensitive Devices](#)" on page 21.
- Before starting, make sure that the plastic socket cap is in place and none of the socket pins are bent. If any damage is noted, contact your retailer.
- Do not connect the system power cord before the processor and heatsink installation is complete.
- When handling the processor, avoid touching or placing direct pressure on the LGA lands (gold contacts). Improper installation or socket misalignment can cause serious damage to the processor or processor socket.
- Install the processor in the socket and the motherboard into the chassis before installing the heatsink.
- When buying a processor separately, use only a Supermicro certified heatsink.
- Refer to the Supermicro website for the most recent processor support.
- When installing the heatsink, ensure a torque driver set to the correct force is used for each screw.
- Thermal grease is pre-applied on a new heatsink. No additional thermal grease is needed.

### Preparing the Processor Socket

1. Remove the screw holding down the force frame. The spring-loaded force frame will raise up. Allow it to lift up to its stopped position.

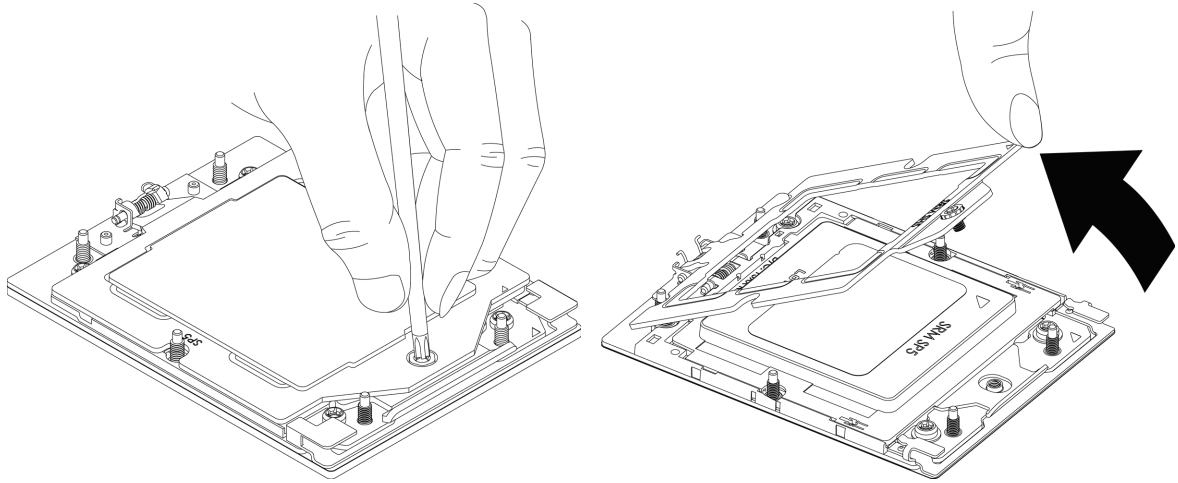

**Figure 2-5. Removing Screw from the Force Frame**

2. Lift the rail frame up by gripping the lift tabs near the front end of the rail frame. While keeping a secure grip of the rail frame, lift it to a position so you can do the next step of removing the external cap.

**Note:** The rail frame is spring loaded, so keep a secure grip on it as you lift it so it does not snap up.

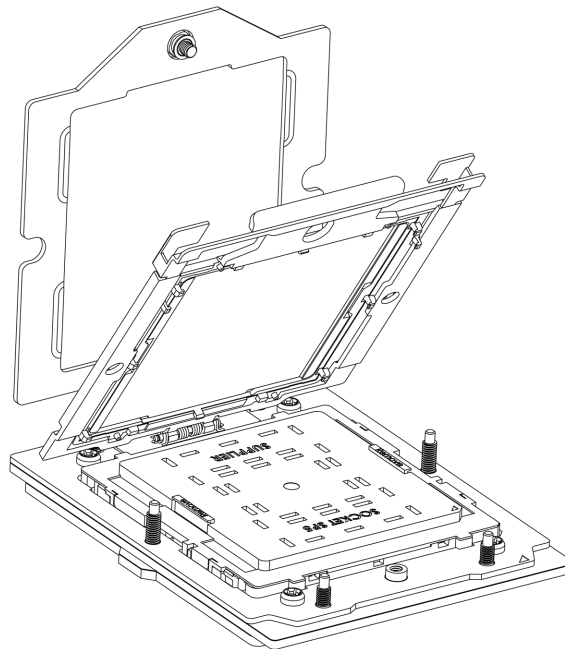

**Figure 2-6. Lifting the Frame**

3. Remove the external cap from the rail frame by pulling it upwards through the rail guides on the rail frame.

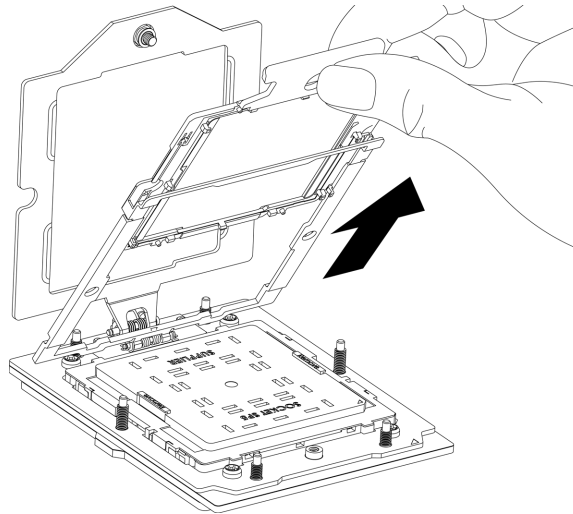
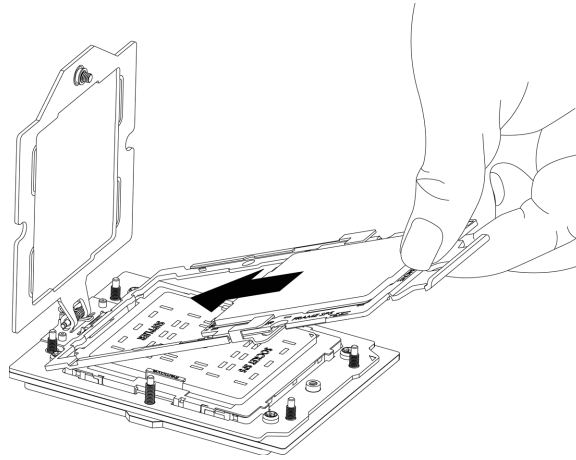

**Figure 2-7. Removing the Cap**

## Installing the Processor into the Frame

1. The processor package is shipped from the factory with the carrier frame pre-assembled. Grip the handle of the carrier frame/processor assembly from its shipping tray, and while gripping the handle, align the flanges of the carrier frame onto the rails of the rail frame so its pins will be at the bottom when the rail frame is lowered later.
2. Slide the carrier frame/processor assembly downwards to the bottom of the rail frame. Ensure the flanges are secure on the rails as you lower it downwards.

**Note:** You can only install the processor inside the socket in one direction with the handle at the top. Make sure that it is properly inserted into the socket before closing the rail frame plate. If it doesn't close properly, do not force it as it may damage your processor. Instead, open the rail frame plate again, and double-check that the processor is aligned properly.



**Figure 2-8. Installing into the Rail Frame**

3. Lift up the rail frame until it securely rests in an upright position. Then remove the cover cap from the socket below. Grip the two lift tabs marked "Remove" at the middle of the cap and pull vertically upwards to remove the cover cap.

**Important:** The exposed socket contacts are extremely vulnerable and can be damaged easily. Do not touch or drop objects onto the contacts and be careful removing the cover cap and when placing the rail frame over the socket.

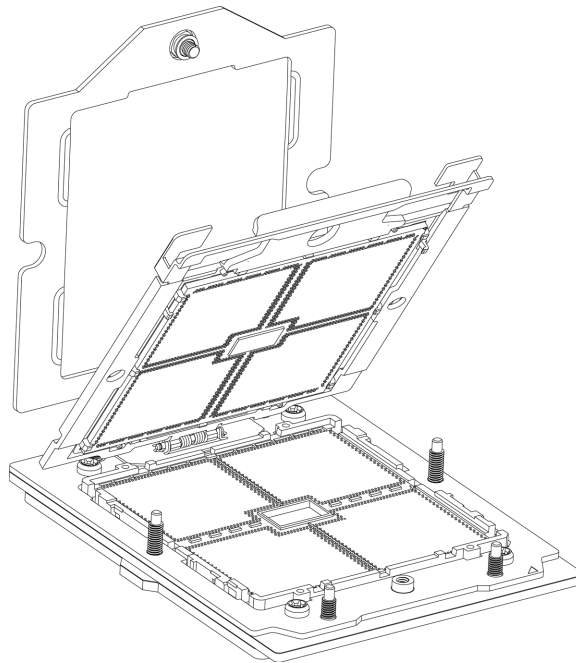

**Figure 2-9. Removing the Cover Cap**

4. Gently lower the rail frame down onto the socket until the latches on the rail frame engage with the socket housing and it rests in place. Do not force it into place! Note that the force frame is spring loaded and must be held in place before it is secured.

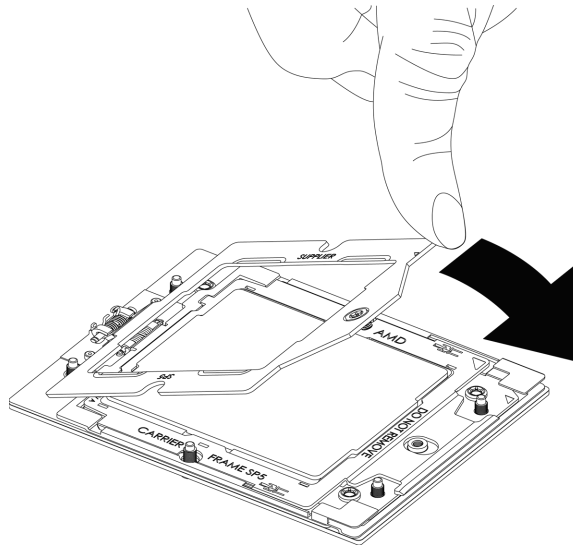

**Figure 2-10. Securing the Force Frame**

5. Use a T20 bit torque driver, set at 12.5–15.0 kgf-cm (10.8–13.0 lbf-in) to prevent damage to the processor. Replace and tighten the screws in the same order they were removed. When finished, the force frame will be secure over both the rail frame and processor package.

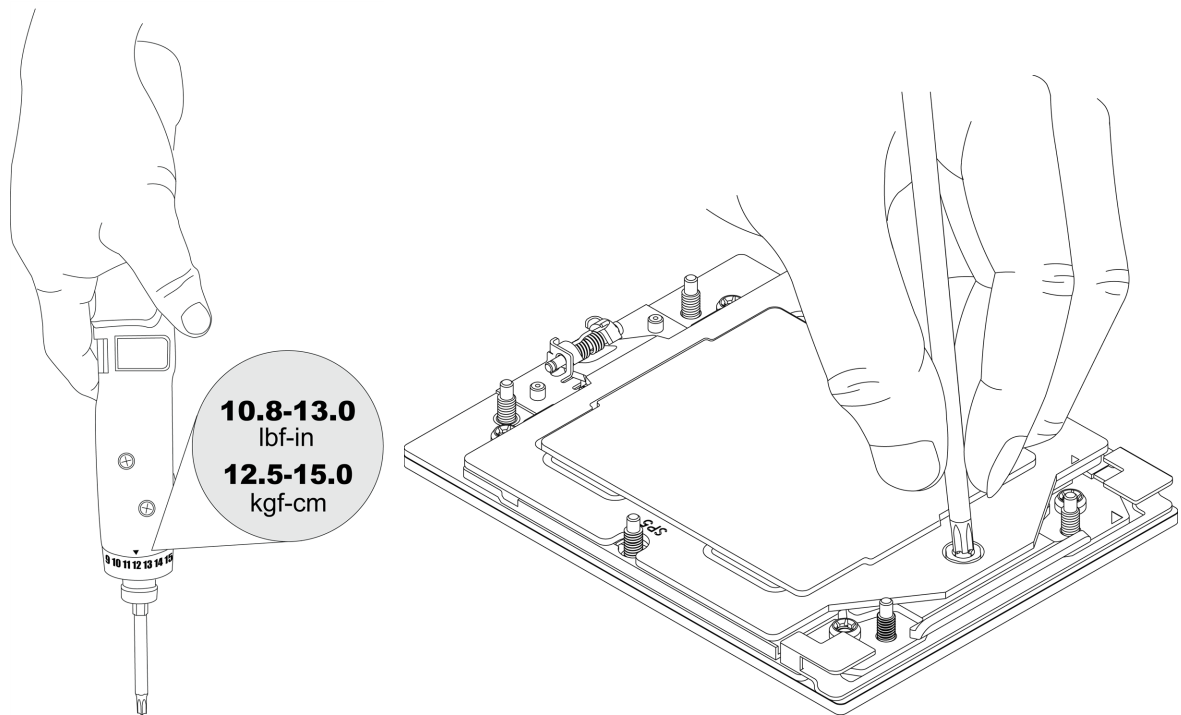
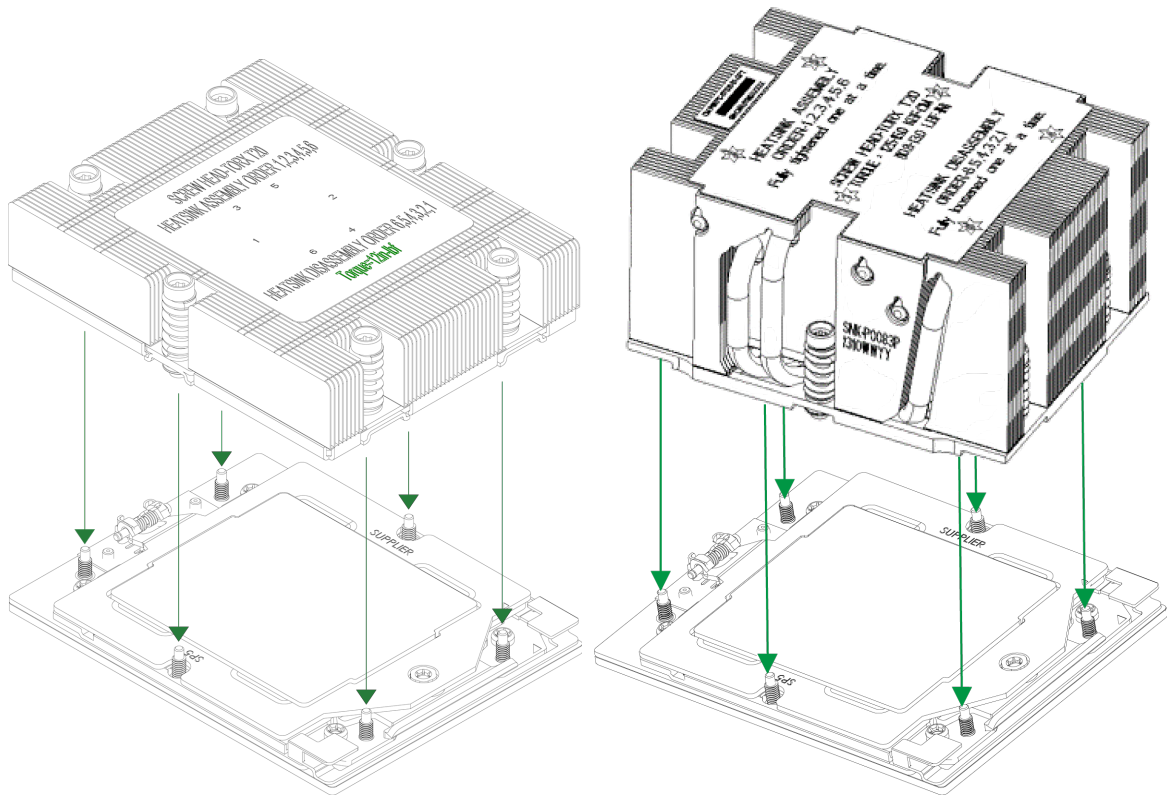

**Figure 2-11. Replacing Screws with Torque Driver**

## **Installing the Heatsink**

After the force frame is secured and the processor is in place, install the heatsink onto the processor.

1. Place the heatsink so that it rests on the processor aligning the six screws on the socket frame.



**Figure 2-12. Placing the Heatsink (1U left, 2U right)**

- Using a T20 torque driver, tighten the screws using the diagonal tightening pattern and torque specifications printed on the heatsink. Tighten the two center screws completely before tightening the four corner screws.

The heatsink is now secured.

## Uninstalling the Heatsink and Processor

- Remove the screws holding the heatsink and gently work it loose.
- Clean the thermal grease left by the heatsink on the processor assembly to limit the risk of contaminating the land pads or contacts in the socket housing.
- Unscrew the plate and lift the force frame to the vertical position.
- Lift the rail frame using the lift tabs near the front end of the rail frame. Note that the rail frame is spring loaded, so be careful lifting it up into a vertical position.
- Grip the handle of the carrier frame and pull upwards to extract it from the rail frame. Return the processor assembly to its original shipping container.
- Grip the handle on the external cap and return it to the rail frame, sliding it downwards until it rests in the frame.

7. Gripping the rail frame, rotate it downwards until it rests above and locks over the socket housing in its horizontal position.
8. Push and rotate down the force frame until it is over the external cap and rail frame in a horizontal position.
9. While holding down the force frame, secure it back to the socket frame by securing screw #1 in place.

## 2.4 Memory Support and Installation

**Important:** To prevent any damage, exercise extreme care when installing or removing memory modules.

**Note:** Check the Supermicro website for recommended memory modules.

### Memory Support

The H14SST-GE motherboard supports up to 3 TB of ECC DDR5 RDIMM/3DS RDIMM memory in 12 DIMM slots.

Populating RDIMM/3DS RDIMM DDR5 Memory Modules with AMD EPYC™ 9005 Series Processors				
Type	DIMM Population	Maximum Frequency (MT/s)		
	DIMM1	6400 MT/s Grade DIMM	5600 MT/s Grade DIMM	4800 MT/s Grade DIMM
RDIMM	1R (1 rank)	6400	5600	4800
	2R (2 ranks)			
3DS RDIMM	2S2R (4 ranks)			
	2S4R (8 ranks)			

DIMM Population Guide												
Slots Used	Channel											
	F1	E1	D1	C1	B1	A1	G1	H1	I1	J1	K1	L1
1 DIMM						V						
2 DIMMs						V	V					
4 DIMMs				V		V	V		V			
6 DIMMs				V	V	V	V	V	V			
8 DIMMs		V		V	V	V	V	V	V		V	
10 DIMMs		V	V	V	V	V	V	V	V	V	V	
12 DIMMs	V	V	V	V	V	V	V	V	V	V	V	V

## General Guidelines for Optimizing Memory Performance

- It is recommended to use DDR5 memory of the same type, size, and speed.
- Mixed DIMM speeds can be installed. However, all DIMMs will run at the speed of the slowest DIMM.
- The motherboard will support an odd number amount of memory modules. However, to achieve the best memory performance, a balanced memory population is recommended.

## DIMM Installation

**Important:** To avoid causing any damage to the memory module or the DIMM socket, do not use excessive force when pressing the release tabs on the ends of the DIMM socket. Handle memory modules with care. To avoid ESD-related damage to your memory modules or components, carefully follow all the instructions given in "[Static-Sensitive Devices](#)" on [page 21](#).

1. Insert the desired number of DIMMs into the memory slots based on the recommended DIMM population table earlier in this section.
2. Push the release tabs outwards on both ends of the DIMM slot to unlock it.

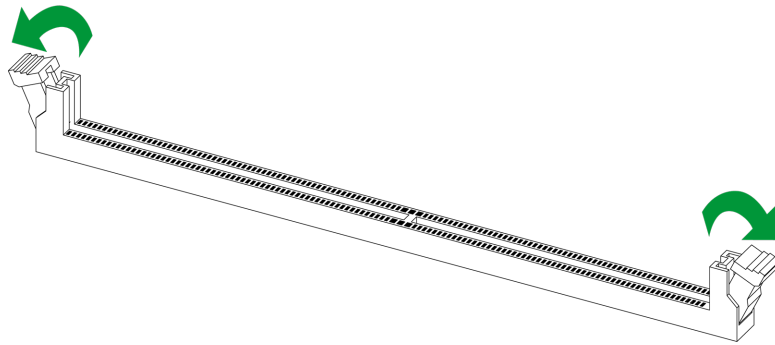

**Figure 2-13. Unlocking the DIMM Slot**

3. Align the key of the DIMM with the receptive point on the memory slot.

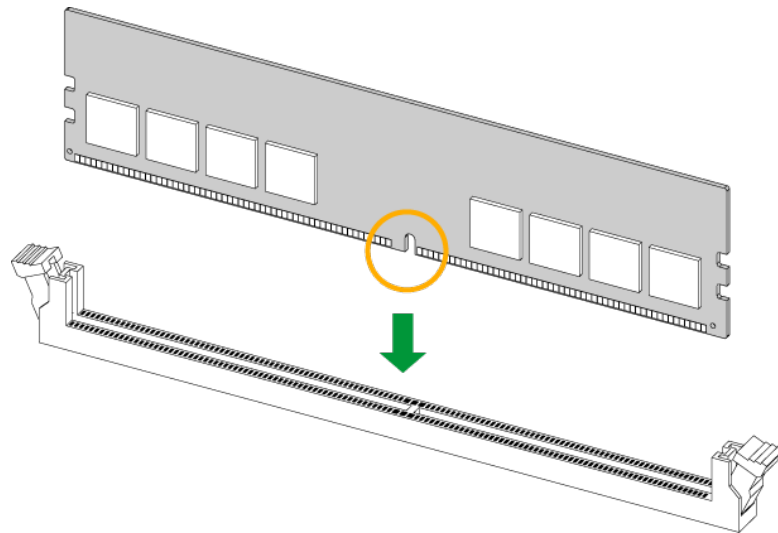

**Figure 2-14. Aligning the DIMM Slot with the Receptive Point**

4. Align the notches on both ends of the module against the receptive points on the ends of the slot.

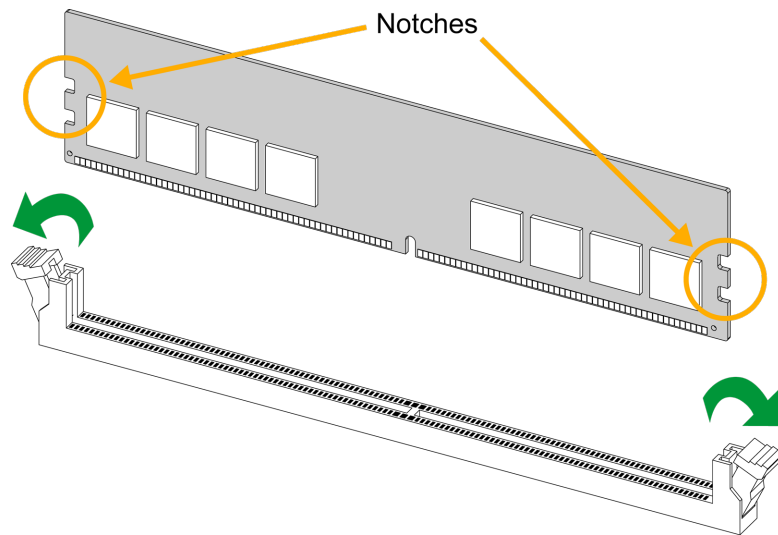

**Figure 2-15. Aligning the Notches**

5. Press both ends of the module straight down into the slot until the module snaps into place.
6. Press the release tabs to the lock positions to secure the DIMM into the slot.

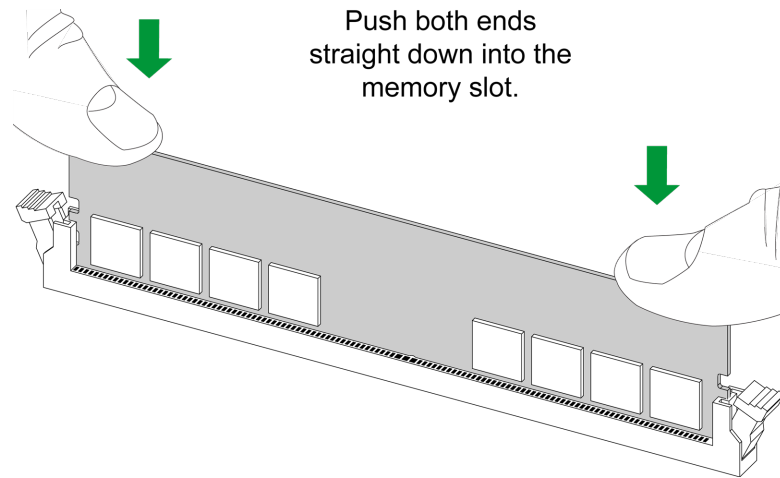

**Figure 2-16. Securing the DIMM**

For a detailed diagram of the H14SST-GE motherboard, see the layout under ["Quick Reference"](#) on page 11.

## DIMM Removal

**Important:** To avoid causing any damage to the memory module or the DIMM socket, do not use excessive force when pressing the release tabs on the ends of the DIMM socket. Handle memory modules with care. To avoid ESD-related damage to your memory modules or components, carefully follow all the instructions given in ["Static-Sensitive Devices"](#) on page 21.

Press both release tabs on the ends of the DIMM socket to unlock it. Once the DIMM is loosened, remove it from the memory slot.

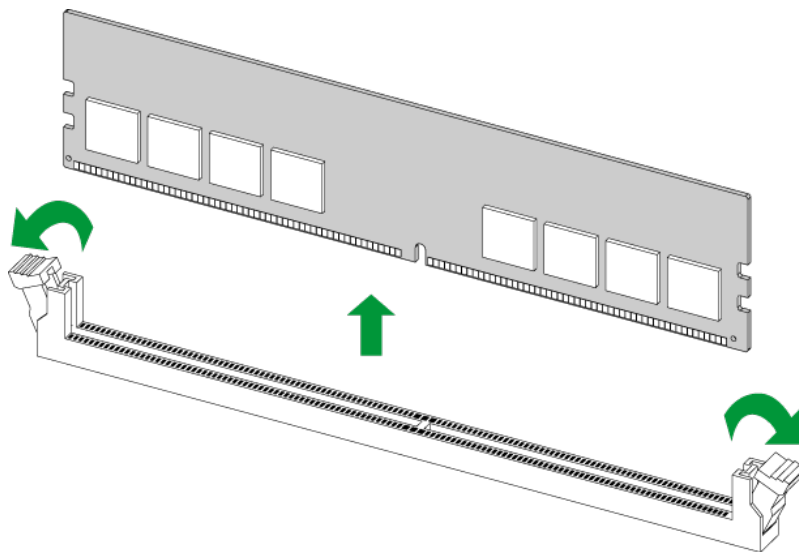

**Figure 2-17. Unlocking the DIMM Slot**

For a detailed diagram of the H14SST-GE motherboard, see the layout under ["Quick Reference"](#) on page 11.

## 2.5 Battery Removal and Installation

### Battery Removal

To remove the onboard battery, follow the steps below:

1. Power off your system and unplug your power cable.
2. Place the system on a workbench.
3. Remove the top cover from the system.
4. Locate the onboard battery as shown below.
5. Using a tool such as a pen or a small screwdriver, push the battery lock outwards to unlock it. Once unlocked, the battery will pop out from the holder.
6. Remove the battery.

### Proper Battery Disposal

**Important:** Handle used batteries carefully. Do not damage the battery in any way; a damaged battery may release hazardous materials into the environment. Do not discard a used battery in the garbage or a public landfill. Comply with the regulations set up by your local hazardous waste management agency to dispose of your used battery properly.

### Battery Installation

To install an onboard battery, follow steps 1 and 2 above and continue below:

**Important:** When replacing a battery, be sure to only replace it with the same type.

1. Identify the battery's polarity. The positive (+) side should be facing up.
2. Insert the battery into the battery holder and push it down until you hear a click to ensure that the battery is securely locked.

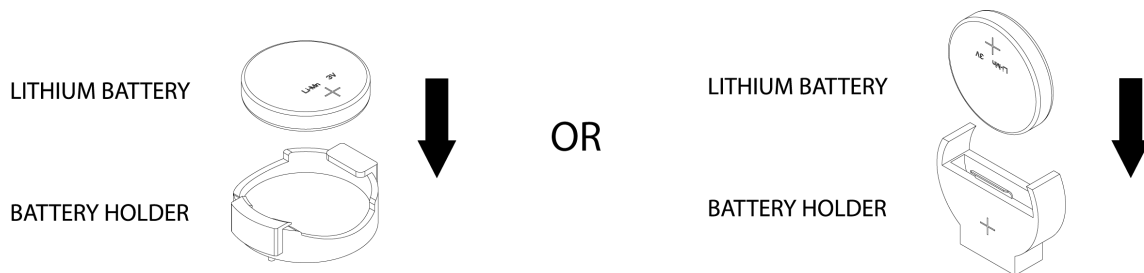

**Figure 2-18. Installing a Battery**

## 2.6 Connections, Jumpers, and LEDs

Refer to the following sections for information about connections, jumpers, and LEDs for the H14SST-GE motherboard.

### Power Supply and Power Connections

For information about the power supply and power connections of the H14SST-GE motherboard, refer to the following content.

#### Power Supply

As with all computer products, a stable power source is necessary for proper and reliable operation. It is even more important for processors that have high CPU clock rates where noisy power transmission is present.

#### Power Connectors

JPW1–JPW4 are 4-pin +12 V DC power connectors on the motherboard that provide adequate power to your system. JPW5 is the 8-pin power connector for SATA backplane power. JPW6 is the 8-pin power connector for PCIe card power.

4-pin Power Connectors Pin Definitions: Four Total	
Pin#	Definition
1–2	GND
3–4	+12 V (12 V Power)

8-pin Power Connectors for SATA Backplane Pin Definitions: Eight Total	
Pin#	Definition
1–4	GND
5–6	+12 V
7–8	+5 V

8-pin Power Connector for PCIe Card Pin Definitions: Eight Total	
Pin#	Definition
1–4	GND
5–8	+12 V

### Headers and Connections

For information about the headers on the H14SST-GE motherboard, refer to the following content.

#### AIOM Sideband Signal Header

This motherboard supports an AIOM slot, which has support for an AIOM sideband header. Use the header located at JAIOMSB1 on the H14SST-GE motherboard for sideband communication.

For a detailed diagram of the H14SST-GE motherboard, see the layout under "[Quick Reference](#)" on page 11.

### ***M.2 M-Key PCIe 5.0 x4 Slots***

Two M.2 M-key slots are located M.2-H1 and M.2-H2 on the H14SST-GE motherboard. The M.2 M-key slots on the motherboard support PCIe 5.0 x4 NVMe SSD devices in a 2280/22110 form factor.

For a detailed diagram of the H14SST-GE motherboard, see the layout under "[Quick Reference](#)" on page 11.

### ***MCIO PCIe 5.0 x8 Connectors***

Mini Cool Edge IO (MCIO) PCIe 5.0 x8 connectors are located at JMCIO1–JMCIO9 on the H14SST-GE motherboard.

For a detailed diagram of the H14SST-GE motherboard, see the layout under "[Quick Reference](#)" on page 11.

### ***NC-SI Connection***

The Network Controller Sideband Interface (NC-SI) connection is located on the H14SST-GE motherboard. This connection is used to connect a Network Interface Card (NIC) to the motherboard to allow the onboard Baseboard Management Controller (BMC) to communicate with a network.

**Note:** For detailed instructions on how to configure Network Interface Card (NIC) settings, refer to the Network Interface Card Configuration User's Guide posted on the web page under the link: <https://www.supermicro.com/support/manuals>.

For a detailed diagram of the H14SST-GE motherboard, see the layout under "[Quick Reference](#)" on page 11.

### ***TPM/Port 80 Header***

The JTPM1 header on the H14SST-GE motherboard is used to connect a Trusted Platform Module (TPM)/Port 80, which is available from Supermicro (optional). A TPM/Port 80 connector is a security device that supports encryption and authentication in hard drives. It allows the motherboard to deny access if the TPM associated with the hard drive is not installed in the system. Information on the TPM is available at the following pages:

[https://www.supermicro.com/manuals/other/AOM-TPM-9671V\\_9671H.pdf](https://www.supermicro.com/manuals/other/AOM-TPM-9671V_9671H.pdf)

<https://www.supermicro.com/manuals/other/AOM-TPM-9672V.pdf>

For a detailed diagram of the H14SST-GE motherboard, see the layout under "[Quick Reference](#)" on page 11.

Trusted Platform Module Header			
Pin Definitions: 10 Total			
Pin#	Definition	Pin#	Definition
1	+3.3 V	2	SPI_CS#
3	RESET#	4	SPI_MISO
5	SPI_CLK	6	Ground
7	SPI_MOSI	8	No Connection
9	+1.8 V Standby	10	SPI_IRQ#

## Jumper Settings

To modify the operation of the motherboard, jumpers can be used to choose between optional settings. Jumpers create shorts between two pins to change the function of the connector. Pin 1 is identified with a square solder pad on the printed circuit board. See the diagram below for an example of jumping pins 1 and 2. Refer to the motherboard layout page for jumper locations.

**Note:** On two-pin jumpers, "Closed" means the jumper is on and "Open" means the jumper is off the pins.

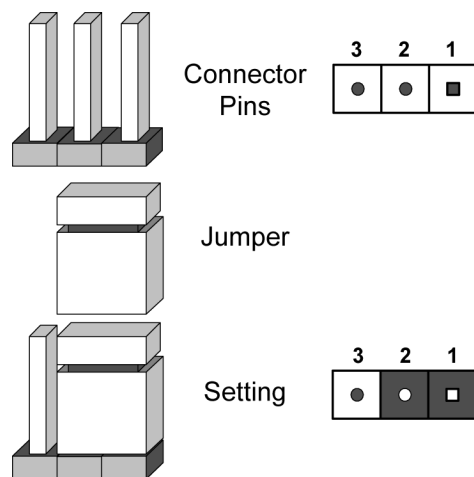

Figure 2-19. Jumping Connector Pins

## CMOS Clear

JBT1 on the H14SST-GE motherboard is used to clear CMOS, which will also clear any passwords. Instead of pins, this jumper consists of contact pads to prevent accidentally clearing the contents of CMOS.

For a detailed diagram of the H14SST-GE motherboard, see the layout under ["Quick Reference"](#) on page 11.



JBT1 contact pads

1. First power down the system and unplug the power cord(s).
2. Remove the cover of the chassis to access the motherboard.
3. Remove the onboard battery from the motherboard.
4. Short the CMOS pads, JBT1, with a metal object such as a small screwdriver for at least four seconds.

**Note:** Clearing CMOS will also clear all passwords.

5. Remove the screwdriver (or shorting device).
6. Replace the cover, reconnect the power cord(s), and power on the system.

## LED Indicators

For information about the LED indicators on the H14SST-GE motherboard, refer to the following content.

### ***BMC Heartbeat LED***

A BMC Heartbeat LED is located at LEDBMC on the H14SST-GE motherboard. When this LED is blinking, the BMC is functioning normally.

For a detailed diagram of the H14SST-GE motherboard, see the layout under "[Quick Reference](#)" on page 11.

<b>BMC Heartbeat LED Indicator</b>	
<b>LED Color</b>	<b>Definition</b>
Green: Blinking	BMC Normal
Green Blinking Fast	BMC Initializing

### ***Onboard Power LED***

The Onboard Power LED is located at LEDPWR on the H14SST-GE motherboard. When this LED is on, the system is on. Be sure to turn off the system and unplug the power cord before removing or installing components.

For a detailed diagram of the H14SST-GE motherboard, see the layout under "[Quick Reference](#)" on page 11.

<b>Onboard Power LED Indicator</b>	
<b>LED Color</b>	<b>Definition</b>
Off	System Power Off (power cable not connected)
Green	System Power On

### ***Unit ID (UID) LED***

The UID LED indicator is located on the H14SST-GE motherboard. This UID indicator provides easy identification of a system that may need to be serviced.

For a detailed diagram of the H14SST-GE motherboard, see the layout under "[Quick Reference](#)" on page 11.

<b>UID LED LED Indicator</b>	
<b>LED Color</b>	<b>Definitions</b>
Blue: On	System Identified

---

---

# Chapter 3:

## Troubleshooting

The following content contains information on common issues and how to resolve them.

---

<b>3.1 Troubleshooting Procedures</b> .....	<b>44</b>
Before Power On .....	44
No Power .....	44
No Video .....	44
System Boot Failure .....	44
Memory Errors .....	45
Losing the System's Setup Configuration .....	45
If the System Becomes Unstable .....	45
<b>3.2 Technical Support Procedures</b> .....	<b>47</b>
<b>3.3 Motherboard Battery</b> .....	<b>48</b>
<b>3.4 Where to Get Replacement Components</b> .....	<b>49</b>
<b>3.5 Returning Merchandise for Service</b> .....	<b>50</b>
<b>3.6 Feedback</b> .....	<b>51</b>

## 3.1 Troubleshooting Procedures

Use the following procedures to troubleshoot your system. If you have followed all of the procedures below and still need assistance, refer to the ["Technical Support Procedures" on page 47](#) or ["Returning Merchandise for Service" on page 50](#) section(s) in this chapter. Always disconnect the AC power cord before adding, changing or installing any non hot-swap hardware components. If the below steps do not fix the setup configuration problem, contact your vendor for repairs.

### Before Power On

1. Make sure that there are no short circuits between the motherboard and chassis.
2. Disconnect all ribbon/wire cables from the motherboard, including those for the keyboard and mouse.
3. Remove all add-on cards.
4. Install the processor (making sure it is fully seated) and connect the front panel connectors to the motherboard.

### No Power

1. Make sure that there are no short circuits between the motherboard and the chassis.
2. Make sure that the power connectors are properly connected.
3. Check that the 115 V/230 V switch, if available, on the power supply is properly set.
4. Turn the power switch on and off to test the system, if applicable.
5. Check the processor socket for bent pins and make sure the processor is fully seated.
6. The battery on your motherboard may be old. Check to verify that it still supplies approximately 3 VDC. If it does not, replace it with a new one.

### No Video

1. If the power is on, but you do not have video, remove all add-on cards and cables.
2. Remove all memory modules and turn on the system (if the alarm is on, check the specs of memory modules, reset the memory, or try a different one).

### System Boot Failure

If the system does not display Power-On-Self-Test (POST) or does not respond after the power is turned on, do the following:

1. Check the screen for an error message.
2. Clear the CMOS settings by unplugging the power cord and contacting both pads on the CMOS clear jumper. Restart the system. Refer to ["CMOS Clear" on page 40](#).
3. Remove all components from the motherboard and turn on the system with only one DIMM installed. If the system boots, turn off the system and repopulate the components back into the system to retest. Add one component at a time to isolate which one may have caused the system boot issue.

## Memory Errors

When suspecting faulty memory is causing the system issue, check the following:

1. Make sure that the memory modules are compatible with the system and are properly installed. See ["Component Installation" on page 20](#) for installation instructions. (For memory compatibility, refer to the "Tested Memory List" link on the motherboard's product page to see a list of supported memory.)
2. Check if different speeds of DIMMs have been installed. It is strongly recommended that you use the same RAM type and speed for all DIMMs in the system.
3. Make sure that you are using the correct type of DIMMs recommended by the manufacturer.
4. Check for bad DIMMs or slots by swapping a single module among all memory slots and check the results.

## Losing the System's Setup Configuration

1. Make sure that you are using a high-quality power supply. A poor-quality power supply may cause the system to lose the CMOS setup information. Refer to ["Introduction" on page 10](#) for details on recommended power supplies.
2. The battery on your motherboard may be old. Check to verify that it still supplies approximately 3 VDC. If it does not, replace it with a new one.

## If the System Becomes Unstable

If the system becomes unstable during or after OS installation, check the following:

1. Processor/BIOS support: Make sure that your processor is supported and that you have the latest BIOS installed in your system.

2. Memory support: Make sure that the memory modules are supported. Refer to the product page on our website at <https://www.supermicro.com>. Test the modules using memtest86 or a similar utility.

**Note:** Click on the "Tested Memory List" link on the motherboard's product page to see a list of supported memory.

3. Storage Drive support: Make sure that all storage drives work properly. Replace the failed storage drives with good ones.
4. System cooling: Check the system cooling to make sure that all heatsink fans and processor/system fans, etc., work properly. Check the hardware monitoring settings in the IPMI to make sure that the processor and system temperatures are within the normal range. Also, check the front panel Overheat LED and make sure that it is not on.
5. Adequate power supply: Make sure that the power supply provides adequate power to the system. Make sure that all power connectors are connected. Refer to our website for more information on the minimum power requirements.
6. Proper software support: Make sure that the correct drivers are used.

If the system becomes unstable before or during OS installation, check the following:

1. Source of installation: Make sure that the devices used for installation are working properly, including boot devices such as a USB flash or media device.
2. Cable connection: Check to make sure that all cables are connected and working properly.
3. Use the minimum configuration for troubleshooting: Remove all unnecessary components (starting with add-on cards first), and use the minimum configuration (but with the processor and a memory module installed) to identify the trouble areas. Refer to the steps listed above in this section for proper troubleshooting procedures.
4. Identify bad components by isolating them: If necessary, remove a component in question from the chassis, and test it in isolation to make sure that it works properly. Replace a bad component with a good one.
5. Check and change one component at a time instead of changing several items at the same time. This will help isolate and identify the problem.
6. To find out if a component is good, swap this component with a new one to see if the system will work properly. If so, then the old component is bad. You can also install the component in question in another system. If the new system works, the component is good and the old system has problems.

## 3.2 Technical Support Procedures

Before contacting Technical Support, take the following steps. Also, note that as a motherboard manufacturer, Supermicro also sells motherboards through its channels, so it is best to first check with your distributor or reseller for troubleshooting services. They should know of any possible problems with the specific system configuration that was sold to you.

1. Refer to "Troubleshooting Procedures" on page 44 or see the FAQs on our website (<https://www.supermicro.com/FAQ/index.php>) before contacting Technical Support.
2. BIOS upgrades can be downloaded from our website ([https://www.supermicro.com/support/resources/bios\\_ipmi.php](https://www.supermicro.com/support/resources/bios_ipmi.php)).
3. If you still cannot resolve the problem, include the following information when contacting Supermicro for technical support:
  - Motherboard model and PCB revision number
  - BIOS release date/version (This can be seen on the initial display when your system first boots up.)
  - System configuration
4. An example of a Technical Support form is on our website at <https://webpr3.supermicro.com/SupportPortal>.
5. Distributors: For immediate assistance, have your account number ready when placing a call to our Technical Support department. For Supermicro contact information, refer to "Contacting Supermicro" on page 9.

### 3.3 Motherboard Battery

For information on removing, disposing of, and replacing the motherboard battery of your system, refer to ["Battery Removal and Installation"](#) on page 37.

## 3.4 Where to Get Replacement Components

If you need replacement parts for your H14SST-GE motherboard, to ensure the highest level of professional service and technical support, purchase exclusively from our Supermicro Authorized Distributors/System Integrators/Resellers. A list can be found on the Supermicro website:

<https://www.supermicro.com>

Under the "Buy" menu, click the "Where to Buy" link.

## 3.5 Returning Merchandise for Service

A receipt or copy of your invoice marked with the date of purchase is required before any warranty service will be rendered. You can obtain service by calling your vendor for a Returned Merchandise Authorization (RMA) number. When returning the motherboard to the manufacturer, the RMA number should be prominently displayed on the outside of the shipping carton, and the shipping package is mailed prepaid or hand-carried. Shipping and handling charges will be applied for all orders that must be mailed when service is complete.

For faster service, RMA authorizations can be requested online at the following page:

<https://www.supermicro.com/RmaForm>

Whenever possible, repack the motherboard in the original Supermicro carton, using the original packaging material. If these are no longer available, be sure to pack the motherboard securely, using packaging material to surround the motherboard so that it does not shift within the carton and become damaged during shipping.

This warranty only covers normal consumer use and does not cover damages incurred in shipping or from failure due to the alternation, misuse, abuse or improper maintenance of products.

During the warranty period, contact your distributor first for any product problems.

## 3.6 Feedback

Supermicro values your feedback as we strive to improve our customer experience in all facets of our business. Email us at [Techwriterteam@supermicro.com](mailto:Techwriterteam@supermicro.com) to provide feedback on our manuals.

## Chapter 4:

# UEFI BIOS

The following content contains information on BIOS configuration with the H14SST-GE motherboard.

---

<b>4.1 Introduction</b> .....	<b>53</b>
<b>4.2 Main Setup</b> .....	<b>55</b>
<b>4.3 Advanced Setup Configurations</b> .....	<b>57</b>
<b>4.4 BMC</b> .....	<b>80</b>
<b>4.5 Event Logs</b> .....	<b>84</b>
<b>4.6 Security</b> .....	<b>86</b>
<b>4.7 Boot</b> .....	<b>91</b>
<b>4.8 Save &amp; Exit</b> .....	<b>93</b>

## 4.1 Introduction

This chapter describes the AMIBIOS™ Setup utility for the motherboard. The BIOS is stored on a chip and can be easily upgraded using the UEFI script (flash.nsh), the BMC WebUI, or the SuperServer Automation Assistant (SAA) utility.

**Note:** Due to periodic changes to the BIOS, some settings may have been added or deleted and might not yet be recorded in this manual. Refer to the Manual Download area of our website for any changes to BIOS that may not be reflected in this manual.

### Updating BIOS

It is recommended that you do not upgrade your BIOS if you are not experiencing any problems with your system. Updated BIOS files are located on our website at the following page:

[https://www.supermicro.com/support/resources/bios\\_ipmi.php](https://www.supermicro.com/support/resources/bios_ipmi.php)

Check our BIOS warning message and the information on how to update your BIOS on our website. Select your motherboard model and download the BIOS file to your computer. Also, check the current BIOS revision to make sure that it is newer than your BIOS before downloading.

**Important:** Do not shut down or reset the system while updating the BIOS to prevent possible system boot failure! Read the motherboard README file carefully before you perform the BIOS update.

To update the BIOS under the UEFI Shell, unzip the BIOS file onto a bootable USB device and then boot into the built-in UEFI Shell. For motherboards with BMC support, type "flash.nsh <BIOS filename><BMC Username><BMC Password>" to start the BIOS update. The flash.nsh script will invoke the SAA (EFI) tool automatically to perform the BIOS update, beginning with uploading the BIOS image to BMC. After uploading the BIOS image, the system will reboot to continue the process. The BMC will take over and continue the BIOS update in the background. The process will take 3–5 minutes. Refer to the README file for more information.

### Starting the Setup Utility

To enter the BIOS Setup utility, press the <Delete> key while the system is booting-up. In most cases, the <Delete> key is used to invoke the BIOS Setup screen. There are a few cases when other hot keys are used, such as <F1>, <F2>, etc. Each main BIOS menu option is described in this manual.

The Main BIOS screen has two main frames. The left frame displays all the options that can be configured. "Grayed-out" options cannot be configured. The right frame displays the key legend. Above the key legend is an area reserved for a text message. When a BIOS submenu or item is selected in the left frame, it is highlighted in white. Often a text message will accompany it. (Note that BIOS has default text messages built in. We retain the option to include, omit, or change any of these text messages.) Settings printed in **Bold** are the default values.

A "▶" indicates a submenu. Highlighting such an item and pressing the <Enter> key open the list of settings within that submenu.

The BIOS Setup utility uses a key-based navigation system called hot keys. Most of these hot keys (<F1>, <F2>, <F3>, <F4>, <F5>, <F6>, <Enter>, <ESC>, the arrow keys, etc.) can be used at any time during the setup navigation process.

## 4.2 Main Setup

The Main setup screen appears when the AMI BIOS Setup utility is first entered. To return to the Main setup screen, select the Main tab at the top of the screen. The Main BIOS setup screen is shown below.

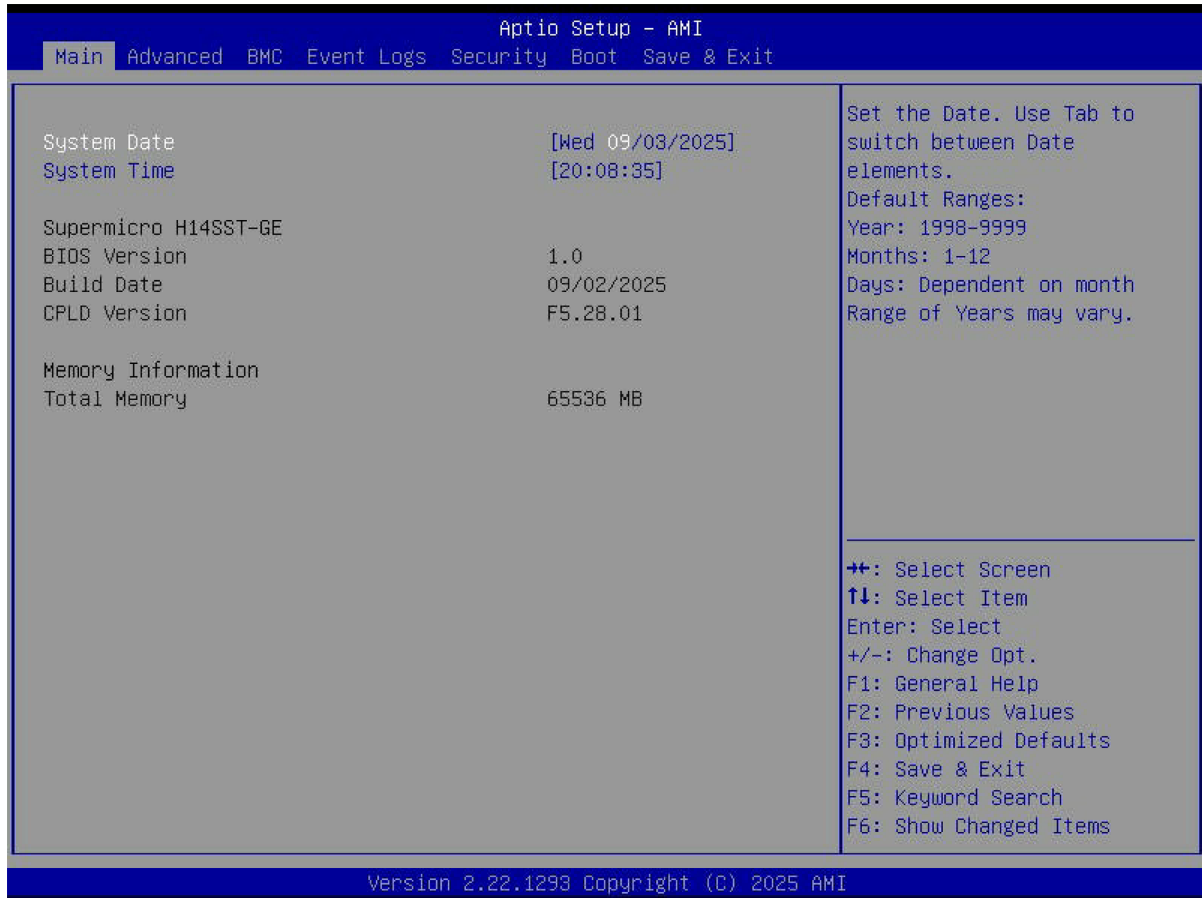

**Figure 4-1. Main Screen**

### System Date/System Time

Use the two features to change the system date and time. Highlight **System Date** or **System Time** using the arrow keys. Enter new values using the keyboard. Press the <Tab> key or the arrow keys to move between fields. The date must be entered in MM/DD/YYYY format. The time is entered in HH:MM:SS format.

**Note:** The time is in the 24-hour format. For example, 5:30 P.M. appears as 17:30:00.

### Supermicro H14SST-GE

#### BIOS Version

This feature displays the version of the BIOS ROM used in the system.

**Build Date**

This feature displays the date when the version of the BIOS ROM used in the system was built.

**CPLD Version**

This feature displays the version of the Complex-Programmable Logical Device (CPLD) used in the system.

**Memory Information****Total Memory**

This feature displays the total size of memory available in the system.

## 4.3 Advanced Setup Configurations

Use the arrow keys to select the Advanced submenu and press <Enter> to access the submenu items.

**Important:** Use caution when changing the Advanced settings. An incorrect value, an improper DRAM frequency, or a wrong BIOS timing setting may cause the system to malfunction. When this occurs, revert the settings to the default manufacturing settings.

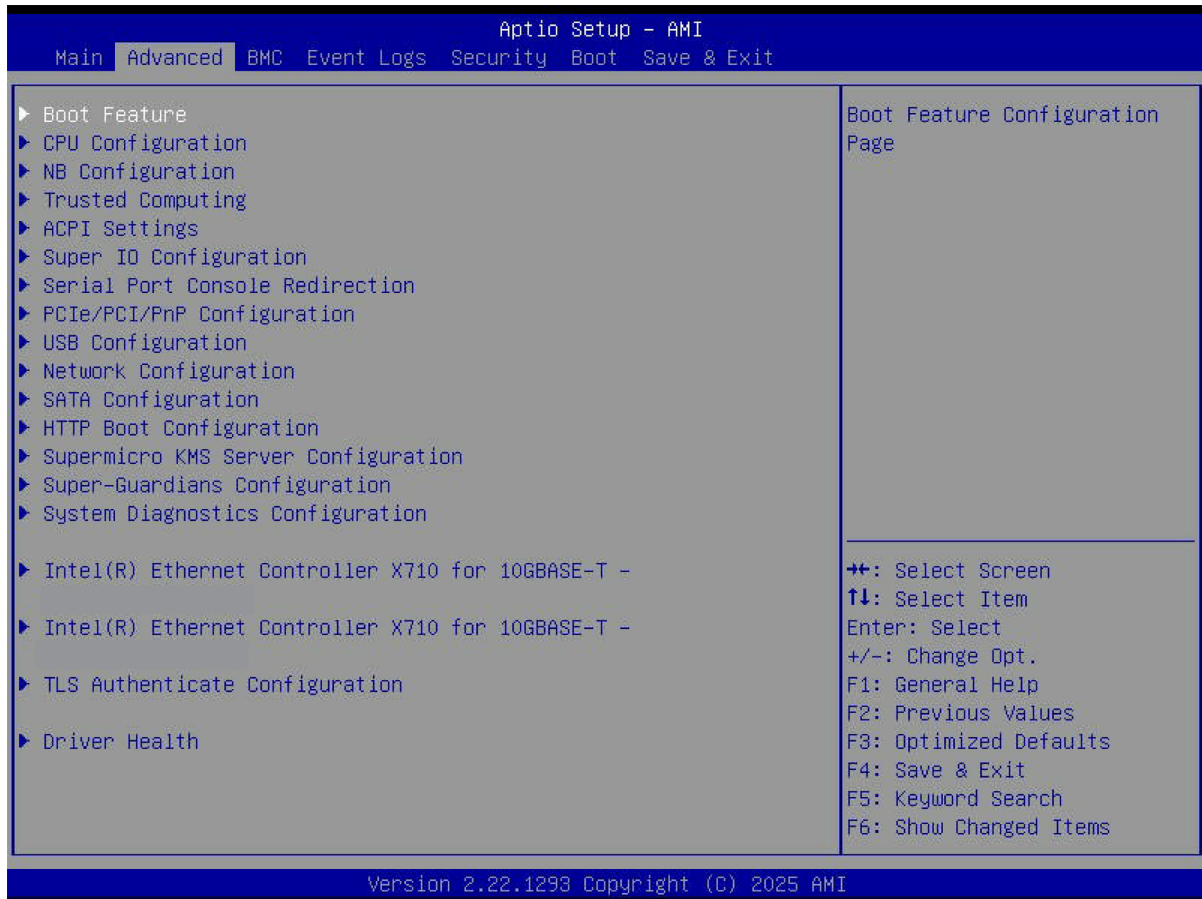

**Figure 4-2. Advanced Setup Configurations Screen**

### Boot Feature Menu

#### ► Boot Feature

##### Quiet Boot

Use this feature to select the screen between displaying the Power-on Self Test (POST) messages or the OEM logo upon bootup. Select Disabled to display the POST messages. Select Enabled to display the OEM logo instead of the normal POST messages. The options

are Disabled and **Enabled**.

**Note:** BIOS POST messages are always displayed regardless of the setting of this feature.

### Option ROM Messages

Use this feature to set the display mode for the Option ROM. Select Keep Current to display the current AddOn ROM display settings. Select Force BIOS to use the Option ROM display mode set by the system BIOS. The options are **Force BIOS** and Keep Current.

### Bootup NumLock State

Use this feature to set the Power-on state for the <Numlock> key. The options are **On** and Off.

### Wait For "F1" If Error

Select Enabled to force the system to wait until the <F1> key is pressed if an error occurs. The options are **Disabled** and Enabled.

### INT19 Trap Response

Interrupt 19 is the software interrupt that handles the boot disk function. When this feature is set to Immediate, the ROM BIOS of the host adaptors will "capture" Interrupt 19 at bootup immediately and allow the drives that are attached to these host adaptors to function as bootable disks. If this feature is set to Postponed, the ROM BIOS of the host adaptors will not capture Interrupt 19 immediately to allow the drives attached to these adaptors to function as bootable devices at bootup. The options are **Immediate** and Postponed.

### Re-try Boot

If this feature is set to Enabled, the system BIOS will automatically reboot the system from an Extensible Firmware Interface (EFI) boot device after an initial boot failure. The options are **Disabled** and Enabled.

### Power Configuration

#### Watch Dog Function

Select Enabled to allow the Watch Dog timer to reboot the system when it is inactive for more than five minutes. The options are **Disabled** and Enabled.

#### Watch Dog Action (Available when "Watch Dog Function" is set to Enabled)

Use this feature to configure the Watch Dog Time\_out setting. The options are **Reset** and NMI.

#### Restore on AC Power Loss

Use this feature to set the power state after a power outage. Select Stay Off for the system power to remain off after a power loss. Select Power On for the system power to be turned on after a power loss. Select Last State to allow the system to resume its last power state before a power loss. The options are Stay Off, Power On, and **Last State**.

## Power Button Function

This feature controls how the system shuts down when the power button is pressed. Select 4 Seconds Override to power off the system after pressing and holding the power button for four seconds or longer. Select Instant Off to instantly power off the system as soon as you press the power button. The options are **Instant Off** and 4 Seconds Override.

## CPU Configuration Menu

### Workload Profile

This function allows configuring the BIOS settings to match the selected workload. The options are **Disabled**, HPC, I/O, Virtualization, and Low Latency.

### SMT Control

This setting is used to disable symmetric multithreading. To re-enable SMT, a power cycle is needed after selecting the Enable option. Select Auto based on BIOS PCD default setting. The options are Disabled, Enabled, and **Auto**.

### Core Performance Boost

Use this setting to configure Core Performance Boost. The options are Disabled and **Auto**.

### Global C-state Control

Controls IO based C-state generation and DF C-states. The options are Disabled, Enabled, and **Auto**.

### ACPI CST C2 Latency

Use this setting to enter in microseconds the decimal value. Larger C2 latency values will reduce the number of C2 transitions and reduce C2 residency. Fewer transitions can help when the performance is sensitive to the latency of C2 entry and exit. The default value is **100**.

### PPIN Opt-in

Select Unlock/Enabled to use the Protected Processor Inventory Number (PPIN) in the system. The PPIN is a unique number set for tracking a given processor. The options are Disabled, Enabled, and **Auto**.

### SMEE

This setting controls Secure Memory Encryption (SME) for the system. The options are Disabled, Enabled, and **Auto**.

### Fast Short REP MOVSB (FSRM)

The default is 1, but it can be set to zero for analysis purposes as long as the OS supports it. The options are **Auto**, Enabled, and Disabled.

**Enhanced REP MOVSB/STOSB (ERSM)**

This setting optimizes CPU string operations. Disabling ERSM (setting it to 0) can be useful for performance analysis if supported by the operating system. The options are Disabled, Enabled, and **Auto**.

**AVX512**

Enable or disable AVX512. The options are **Auto**, Enabled, and Disabled.

**L1 Stream HW Prefetcher**

This setting is used to enable or disable the L1 Stream Hardware Prefetcher. The options are Disabled, Enabled, and **Auto**.

**L2 Stream HW Prefetcher**

This setting is used to enable or disable the L2 Stream Hardware Prefetcher. The options are Disabled, Enabled, and **Auto**.

**CCD Control**

Sets the number of active CCDs. A power cycle is required once this option has been used to remove any CCDs. The options are **Auto**, 2 CCDs, 4 CCDs, 6 CCDs, 8 CCDs, 10 CCDs, 12 CCDs, and 14 CCDs.

**Core Control**

Sets the number of cores to be used. Once this option has been used to remove any cores, a power cycle is required for future selections to take effect. The options are **Auto**, ONE (1+0), TWO (2+0), THREE (3+0), FOUR (4+0), FIVE (5 +0), SIX (6+0), and SEVEN (7+0).

**SVM Mode**

This setting enables or disables CPU Virtualization. The options are Disabled and **Enabled**.

**► CPU1 Information**

Changing the designed PCIe port bifurcation.

CPU information listed,

CPU1 PCIe Package Group P2 The options are **Auto**, x4x4x4x4, x4x4x8, x8x4x4, x8x8, and x16

CPU1 PCIe Package Group G2

CPU1 PCIe Package Group P3

CPU1 PCIe Package Group G3

CPU1 PCIe Package Group P1

CPU1 PCIe Package Group G1

CPU1 PCIe Package Group P0

CPU1 PCIe Package Group G0

## NB Configuration

### North Bridge Configuration

#### IOMMU

Use this setting to enable or disable IOMMU. The options are Disabled, Enabled, and **Auto**.

#### DMAR Support

Use this setting to enable DMAR system protection during POST (Power-On Self-Test). The options are Disabled, Enabled, and **Auto**.

#### DMA Protection

Use this setting to enable DMA remap support in the IVRS IVinfo field. The options are **Auto**, Enabled, and Disabled.

#### DRTM Virtual Device Support

This enables or disables the DRTM ACPI Virtual device. The options are Disabled, Enabled, and **Auto**.

#### DRTM Memory Reservation

This setting reserves 128 MB of memory below for DRTM security functions. It is required to for secured-core servers. The options are Disabled, Enabled, and **Auto**.

#### ACS Enable

This setting enables Access Control Service (ACS) functionality, which requires AER to be active. The options are Enabled, Disabled, and **Auto**.

#### TDP Control

Use this setting to set the processor's power consumption (TDP). The options are Manual and **Auto**.

#### Package Power Limit Control

Use Auto to apply the default power limit (PPT) or Manual to set a custom PPT. The options are Manual and **Auto**.

#### Determinism Control

Use this setting to configure the level of performance determinism. The options are Manual and **Auto**.

**APBDIS**

Use this setting to control the APBDIS feature. A value of 0 indicates "not APBDIS" (mission mode). The options are 0, 1, and **Auto**.

**Power Profile Selection**

Use this setting to select a power profile to optimize performance or efficiency. The options are High Performance Mode, Efficiency Mode, Maximum IO Performance Mode, Balanced Memory Performance Mode, Balanced Core Performance Mode, Balanced Core Memory Performance Mode, and **Auto**.

**DF Cstates**

This setting controls the power-saving states of the data fabric. The options are Disabled, Enabled, and **Auto**.

**Data Link Feature Cap**

This setting controls the activation of advanced data link features for PCIe devices, which can improve link performance and reliability. The options are Enabled, Disabled, and **Auto**.

**SEV-SNP Support**

This setting controls the activation of Secure Encrypted Virtualization - Secure Nested Paging (SEV-SNP) security features. The options are Disabled, Enabled, and **Auto**.

**Periodic Training Mode**

This setting controls the method for managing power-saving states. The options are Disabled and **Legacy**.

**EQ Bypass To Highest Rate**

This setting determines whether the system can bypass equalization steps at lower data rates and directly attempt equalization at the highest supported rate during the link setup process. The options are Disable, Enable, and **Auto**.

**CXL Memory Attribute**

This setting determines the memory type for CXL devices. The options are **Auto**, Enabled, and Disabled.

**Sync Header Bypass**

This setting controls the inclusion of synchronization headers in data transmissions. The options are **Auto**, Enabled, and Disabled.

## ► Memory Configuration

### Memory Target Speed

Use this setting to specify the memory target speed in MT/s. The options are **Auto**, DDR3600, DDR4000, DDR4400, DDR4800, DDR5200, DDR5600, DDR6000, and DDR6400.

### Memory Interleaving

This setting controls fabric level memory interleaving. Note that the channel, die and socket have requirements on memory populations and it will be ignored if the memory doesn't support the selected option. The options are Disabled, Enabled, and **Auto**.

### Chipselect Interleaving

This setting allows memory blocks to be interleaved across the DRAM chip selects for node 0, which can enhance memory performance. The options are Disabled and **Auto**.

### BankSwapMode

This setting determines the operation of memory banks in relation to CPU usage. The options are **Auto**, Disabled, and Swap CPU.

### Power Down Enable

Use this setting to enable or disable DDR power down mode. The options are Disabled, Enabled, and **Auto**.

### DRAM Scrub Time

This setting specifies the frequency of memory scrubbing, which helps maintain data integrity by refreshing memory contents. The options are Disabled, 1 hour, 4 hours, 6 hours, 8 hours, 12 hours, 16 hours, **24 hours**, and 48 hours.

### TSME

This setting controls the Transparent Secure Memory Encryption feature. The options are **Auto**, Enabled, and Disabled.

### Enhanced PPR

Use this setting to enable a full memory test during system setup. While this thorough testing can enhance system stability, it will also increase the overall boot time. The options are **Disabled** and Enabled.

## ► CPU1 Memory Information

View memory information for CPU1.

## Trusted Computing Menu

### Configuration

#### Security Device Support

If this feature and the TPM jumper on the motherboard are both set to Enabled, onboard security devices will be enabled for Trusted Platform Module (TPM) support to enhance data integrity and network security. Please reboot the system for a change on this setting to take effect. The options are Disabled and **Enabled**.

When "Security Device Support" is set to Enabled and a TPM 2.0 device is detected by the BIOS, the following information is displayed.

- Active PCR banks
- Available PCR banks

**Note:** The following features are available when a TPM 2.0 device is detected by the BIOS.

## ACPI Settings Menu

### ► ACPI Settings

#### High Precision Event Timer

The High Precision Even Timber (HPET) is a hardware timer that provides high-resolution time stamps and periodic interrupts, used by the operating system for various timing-related tasks. The options are Disabled and **Enabled**.

#### PCI AER Support

This setting controls the Advanced Error Reporting (AER) capability for PCIe devices in the system. The options are Enabled and **Disabled**.

#### NUMA Nodes per Socket

A NUMA architecture divides hardware resources, including processors, memory, and I/O buses, into groups, called NUMA nodes. This setting specifies the number of desired NUMA nodes per sockets. Selecting Zero will attempt to interleave the two sockets together. **Auto** is equivalent to NPS1. The options are NPS0, NPS1, NPS2, NPS4, and **Auto**.

#### ACPI SRAT L3 Cache As NUMA Domain

This setting determines how the system's Non-Uniform Memory Access (NUMA) domains are defined in relation to the L3 cache. The options are Disabled, Enabled, and **Auto**.

## Super IO Configuration Menu

### ► Super IO Configuration

**Note:** This submenu is available when your system supports this feature.

The following information is displayed.

- Super IO Chip

Select for Serial Port 2.

### *Serial Port 2 Configuration Menu*

#### **Serial Port 2 Configuration**

##### **Serial Port 2/SOL ("Serial Port 2" or "SOL" based on your system support)**

Select Enabled to enable serial port 2 (or SOL). The options are Disabled and **Enabled**.

##### **Device Settings (Available when "Serial Port 2/SOL" above is set to Enabled)**

This feature displays the base I/O port address and the Interrupt Request address of serial port 2 (or SOL).

##### **Change Settings (Available when "Serial Port 2/SOL" above is set to Enabled)**

Use this feature to specify the base I/O port address and the Interrupt Request address of serial port 2 (or SOL). Select Auto for the BIOS to automatically assign the base I/O and IRQ address to serial port 2 (or SOL). The options are **Auto**, (IO=2F8h; IRQ=3;), (IO=3F8h; IRQ=3,4,5,6,7,9,10,11,12;), (IO=2F8h; IRQ=3,4,5,6,7,9,10,11,12;), (IO=3E8h; IRQ=3,4,5,6,7,9,10,11,12;), and (IO=2E8h; IRQ=3,4,5,6,7,9,10,11,12;).

##### **Serial Port 2 Attribute (Available for Serial Port 2 only)**

Select SOL to use serial port 2 as a Serial Over LAN (SOL) port for console redirection.

## Serial Port Console Redirection Menu

### **SOL/COM2**

**Note:** This feature is available when your system supports serial port of SOL and/or COM2. The "SOL/COM2" here indicates a shared serial port, and SOL is used as the default.

#### **Console Redirection**

Select Enabled to use the SOL/COM2 port for Console Redirection. The options are Disabled and **Enabled**.

### ► Console Redirection Settings

**Note:** This submenu is available when "Console Redirection" for SOL/COM2 is set to Enabled.

### **Terminal Type**

Use this feature to select the target terminal emulation type for Console Redirection. Select VT100 to use the ASCII Character set. Select VT100+ to add color and function key support. Select ANSI to use the Extended ASCII Character Set. Select VT-UTF8 to use UTF8 encoding to map Unicode characters into one or more bytes. The options are VT100, **VT100+**, VT-UTF8, and ANSI.

### **Bits Per Second**

Use this feature to set the transmission speed for a serial port used in Console Redirection. Make sure that the same speed is used in the host computer and the client computer. A lower transmission speed may be required for long and busy lines. The options are 9600, 19200, 38400, 57600, and **115200** (bits per second).

### **Data Bits**

Use this feature to set the data transmission size for Console Redirection. The options are 7 and **8** (bits).

### **Parity**

A parity bit can be sent along with regular data bits to detect data transmission errors. Select Even if the parity bit is set to 0, and the number of 1's in data bits is even. Select Odd if the parity bit is set to 0, and the number of 1's in data bits is odd. Select None if you do not want to send a parity bit with your data bits in transmission. Select Mark to add a mark as a parity bit to be sent along with the data bits. Select Space to add a Space as a parity bit to be sent with your data bits. The options are **None**, Even, Odd, Mark, and Space.

### **Stop Bits**

A stop bit indicates the end of a serial data packet. Select 1 Stop Bit for standard serial data communication. Select 2 Stop Bits if slower devices are used. The options are **1** and 2.

### **Flow Control**

Use this feature to set the flow control for Console Redirection to prevent data loss caused by buffer overflow. Send a "Stop" signal to stop sending data when the receiving buffer is full. Send a "Start" signal to start sending data when the receiving buffer is empty. The options are **None** and Hardware RTS/CTS.

### **VT-UTF8 Combo Key Support**

Select Enabled to enable VT-UTF8 Combination Key support for ANSI/VT100 terminals. The options are Disabled and **Enabled**.

### Recorder Mode

Select Enabled to capture the data displayed on a terminal and send it as text messages to a remote server. The options are **Disabled** and Enabled.

### Resolution 100x31

Select Enabled for extended-terminal resolution support. The options are Disabled and **Enabled**.

### Putty KeyPad

This feature selects Function Keys and KeyPad settings for Putty, which is a terminal emulator designed for the Windows OS. The options are **VT100**, LINUX, XTERMR6, SCO, ESCN, and VT400.

## Legacy Console Redirection

### ► Legacy Console Redirection Settings

#### Legacy Serial Redirection Port

Select a COM port to display redirection of legacy OS and legacy OPRM messages. The option is **SOL**.

#### Resolution

On legacy OS, the number of rows and columns supported redirection. The options are 80x24 and **80x25**.

#### Redirection After BIOS Post

When bootloader is selected, then legacy console redirection is disabled before booting to legacy OS. When always is select, then legacy console redirection is enabled for legacy OS. The options are **Always Enable** and BootLoader.

## Serial Port for Out-of-Band Management / Windows Emergency Management Services (EMS)

The feature allows you to configure Console Redirection settings to support Out-of-Band Serial Port management.

### Console Redirection EMS

Select Enabled to use the SOL port for Console Redirection. The options are **Disabled** and Enabled.

### ► Console Redirection Settings

**Note:** This submenu is available when "Console Redirection EMS" is set to Enabled.

### Out-of-Band Mgmt Port

The feature selects a serial port in a client server to be used by the Microsoft Windows Emergency Management Services (EMS) to communicate with a remote host server. The option is **SOL/COM2**. Please note that the option of SOL/COM2 indicates a shared serial port. SOL is available with BMC support.

### Terminal Type EMS

Use this feature to select the target terminal emulation type for Console Redirection. Select VT100 to use the ASCII character set. Select VT100+ to add color and function key support. Select ANSI to use the extended ASCII character set. Select VT-UTF8 to use UTF8 encoding to map Unicode characters into one or more bytes. The options are VT100, VT100+, **VT-UTF8**, and ANSI.

### Bits Per Second EMS

This feature sets the transmission speed for a serial port used in Console Redirection. Make sure that the same speed is used in the host computer and the client computer. A lower transmission speed may be required for long and busy lines. The options are 9600, 19200, 57600, and **115200** (bits per second).

### Flow Control EMS

Use this feature to set the flow control for Console Redirection to prevent data loss caused by buffer overflow. Send a "Stop" signal to stop sending data when the receiving buffer is full. Send a "Start" signal to start sending data when the receiving buffer is empty. The options are **None**, Hardware RTS/CTS, and Software Xon/Xoff.

The following information is displayed.

- **Data Bits EMS**
- **Parity EMS**
- **Stop Bits EMS**

## PCIe/PCI/PnP Configuration Menu

### PCI Bus Driver Version

This item displays the PCI bus driver version.

### PCI Devices Common Settings

#### Re-Size BAR Support

This setting enables or disables the Re-Size Base Address Register feature for compatible PCIe devices, which allows the system to allocate more memory to the device. The options are Disabled and **Enabled**.

**SR-IOV Support**

This setting enables or disables Single Root I/O Virtualization support for the system's PCIe devices. The options are Disabled and **Enabled**.

**BME DMA Mitigation**

This setting enables or disables Bus Mastering Error (BME) Direct Memory Access (DMA) mitigation for protection during the pre-boot process. The options are **Disabled** and Enabled.

**ASPM Support**

Configure the Active State Power Management (ASPM) level for PCIe links to optimize power consumption and performance. The options are **Disabled**, Auto, and Force L1.

**PCIe ARI Support**

This setting enables alternative routing-ID interpretation. The options are Disabled, Enabled, and **Auto**.

**PCIe ARI Enumeration**

This setting controls the forwarding of Alternate Routing-ID Interpretation (ARI) information for each downstream port, which is essential for device identification in PCIe systems. The options are Disabled, Enabled, and **Auto**.

**Relaxed Ordering**

This setting determines whether PCI Express devices are permitted to bypass strict transaction ordering, which can lead to potential performance improvements. The options are Disabled and **Enabled**.

**Clock Spread Spectrum**

This setting allows the BIOS to monitor and reduce the level of Electromagnetic Interference (EMI) generated by system components. The options are **Disabled** and Enabled.

**No Snoop**

This setting configures the No Snoop option for PCI Express devices, determining whether memory accesses bypass the cache. The options are Disabled and **Enabled**.

**VGA Priority**

This setting allows you to choose the primary video output source for the system. The options are **Onboard** and External.

**PCIe Ten Bit Tag Support**

This setting enables the use of ten-bit tags for PCIe devices, which can improve data handling and management. The options are Disabled, Enabled, and **Auto**.

### **NVMe Firmware Source**

This setting determines the source of firmware for NVMe devices, allowing you to select between native support or vendor-specific firmware. The options are **Vendor Defined Firmware** and AMI Native Support.

### **Onboard Video Option ROM**

This setting selects the type of firmware to be loaded for onboard video. The options are Disabled and **EFI**.

### **M.2-H1 OPROM**

This setting enables or disables the Option ROM for the M.2-C1 slot. The options are Disabled and **EFI**.

### **M.2-H2 OPROM**

This setting enables or disables the Option ROM for the M.2-C2 slot. The options are Disabled and **EFI**.

### **AOM-GTG-I2T OPROM**

Select which firmware function to be loaded for onboard LAN1. The options are Disabled and **EFI**.

## **USB Configuration**

USB Configuration

USB Module Version

USB Controllers: 2 XHCIs

USB Devices: 1 Keyboard, 1 Mouse, 3 Hubs

### **XHCI Hand-off**

This setting provides a workaround for operating systems that do not support XHCI hand-off. The XHCI ownership change must be claimed by the XHCI driver. The options are **Enabled** and Disabled.

## **Network Configuration Menu**

### **Network Stack**

Select Enabled to enable Preboot Execution Environment (PXE) or Unified Extensible Firmware Interface (UEFI) for network stack support. The options are Disabled and **Enabled**.

**IPv4 PXE Support (Available when "Network Stack" is set to Enabled)**

Select Enabled to enable IPv4 PXE boot support. If this feature is disabled, it will not create the IPv4 PXE boot option. The options are Disabled and **Enabled**.

**IPv6 HTTP Support (Available when "Network Stack" is set to Enabled)**

Select Enabled to enable IPv6 HTTP boot support. If this feature is disabled, it will not create the IPv6 HTTP boot option. The options are Disabled and **Enabled**.

**PXE Boot Wait Time (Available when "Network Stack" is set to Enabled)**

Use this feature to set the wait time (in seconds) upon which the system BIOS will wait for you to press the <ESC> key to abort PXE boot instead of proceeding with PXE boot by connecting to a network server immediately. Press the <+> or <-> key on your keyboard to change the value. The default value is **0**.

**Media Detect Count (Available when "Network Stack" is set to Enabled)**

Use this feature to set the wait time (in seconds) for the BIOS ROM to detect the presence of a LAN media either via the Internet connection or via a LAN port. Press the <+> or <-> key on your keyboard to change the value. The default value is **1**.

**► IPv4 Network Configuration****Configured**

This setting indicates whether the network address configured successfully. The options are Disabled and **Enabled**.

**Enable DHCP**

The options are **Disabled** and Enabled.

**Local IP Address**

Enter and IP address.

**Local NetMask**

Enter the Netmask address.

**Local Gateway**

Enter the Gateway IP address.

**Local DNS Servers**

Enter the DNS servers IP addresses.

**Save Changes and Exit**

The options are **Yes** and no.

## ► IPv6 Network Configuration

Set IPv6 Network parameters.

### ► Enter Configuration Menu

Interface Name

Interface Type

MAC address

Host addresses

Route Table

Gateway addresses

DNS addresses

Interface ID

#### **DAD Transmit Count**

The number of consecutive Neighbor Solicitation messages sent while performing Duplicate Address Detection on a tentative address. A value of zero indicates that Duplicate Address Detection is not performed. The default value is **1**.

### ► Advanced Configuration

**Note:** This submenu is available when "Policy" is set to Manual.

#### **New IPv6 address**

Use this to set a new manual IP address. It can only be configured under manual policy.

#### **New Gateway addresses**

Use this to set new gateway addresses. Gateway IP addresses can only be configured under manual policy.

#### **New DNS addresses**

Use this to set new DNS addresses. DNS addresses can only be configured under manual policy.

#### **Commit Changes and Exit**

#### **Discard Changes and Exit**

## Policy

Use this feature to select how the policy is to be configured. The options are **Automatic** and **Manual**.

## Save Changes and Exit

The options are **Yes** and **No**.

## ► Advanced Configuration

**Note:** This submenu is available when "Policy" is set to Manual.

### New IPv6 address

Use this to set a new manual IP address. It can only be configured under manual policy.

### New Gateway addresses

Use this to set new gateway addresses. Gateway IP addresses can only be configured under manual policy.

### New DNS addresses

Use this to set new DNS addresses. DNS addresses can only be configured under manual policy.

### Commit Changes and Exit

### Discard Changes and Exit

## Save Changes and Exit

The options are **Yes** and **No**.

## SATA Configuration Menu

### SATA Information

#### SATA Enable

Disable or enable the OnChip SATA controller. The options are Disabled, Enabled, or **Auto**.

#### SATA Information

Provides SATA devices information.

## HTTP Boot Configuration Menu

### HTTP Boot Configuration

#### HTTP Boot Policy

Use this feature to set the HTTP boot policy. The options are Apply to all LANs, **Apply to each LAN**, and Boot Priority #1 instantly.

#### HTTPS Boot Checks Hostname

**Important:** Disabling "HTTPS Boot Checks Hostname" is a violation of RFC 6125 and may expose you to Man-in-the-Middle Attacks. Supermicro is not responsible for any and all security risks incurred by you disabling this feature.

This setting determines whether HTTPS Boot verifies that the hostname in the server's TLS certificate matches the hostname of the remote server. The options are **Enabled** and Disabled (WARNING: Security Risk!!).

#### Priority of HTTP Boot

##### Instance of Priority 1: (Available when your motherboard supports this feature)

This feature sets the rank target port. The default setting is **1**.

#### Select IPv4 or IPv6

This feature specifies which connection the target LAN port should boot from. The options are **IPv4** and IPv6.

#### Boot Description

Use this feature to enter a boot description, which cannot be longer than 75 characters. Please be sure to enter a boot description; otherwise, the boot option for the URI cannot be created.

#### Boot URI

Enter a Boot Uniform Research Identifier (URI) with 128 characters or shorter. This Boot URI determines how IPv4 Boot Option and IPv6 Boot Option will be created. This feature is only supported on Dual or EFI Boot Mode.

##### Instance of Priority 2: (Available when "HTTP Boot Policy" is set to Apply to each LAN or Boot Priority #1 instantly)

This feature sets the rank target port. The default setting is **0**.

## Supermicro KMS Server Configuration Menu

### ► Supermicro KMS Server Configuration

**Note:** Be sure to configure all the features in the submenu of Supermicro KMS Server Configuration and the feature of "KMS Security Policy" in the submenu of Super-Guardians Configuration so that your system can communicate with the KMS server.

#### **Supermicro KMS Server IP address**

Use this feature to set the Supermicro Key Management Service (KMS) server IPv4 address in dotted-decimal notation.

#### **Second Supermicro KMS Server IP address**

Use this feature to set the second Supermicro KMS server IPv4 address in dotted-decimal notation.

#### **Supermicro KMS TCP Port number**

Use this feature to set the TCP port number used in Supermicro KMS Server. The valid range is 100–9999. The default setting is **5696**. Do not change the default setting unless a different TCP port number has been specified and used in the Supermicro KMS Server.

#### **KMS Time Out**

Use this feature to enter the KMS server connecting time-out (in seconds). The default setting is **5** (seconds).

#### **TimeZone**

Use this feature to set the correct time zone. The default setting is **0** (not specified).

#### **Client UserName**

Press <Enter> to set the client identity (UserName). The username can be between 0 and 63 characters in length.

#### **Client Password**

Press <Enter> to set the client identity (Password). The password can be between 0 and 31 characters in length.

### ► CA Certificate

This setting provides options for managing the Certificate Authority (CA) certificate. The options are **Update**, Delete, and Export.

► **Client Certificate**

This setting provides options for managing the client certificate. The options are **Update**, **Delete**, and **Export**.

► **Client Private Key**

Use the three features to enroll factory defaults or load the KMS Transport Layer Security (TLS) certificates, which are generated by the KMS Server, from the file stored in the USB flash drive as shown below.

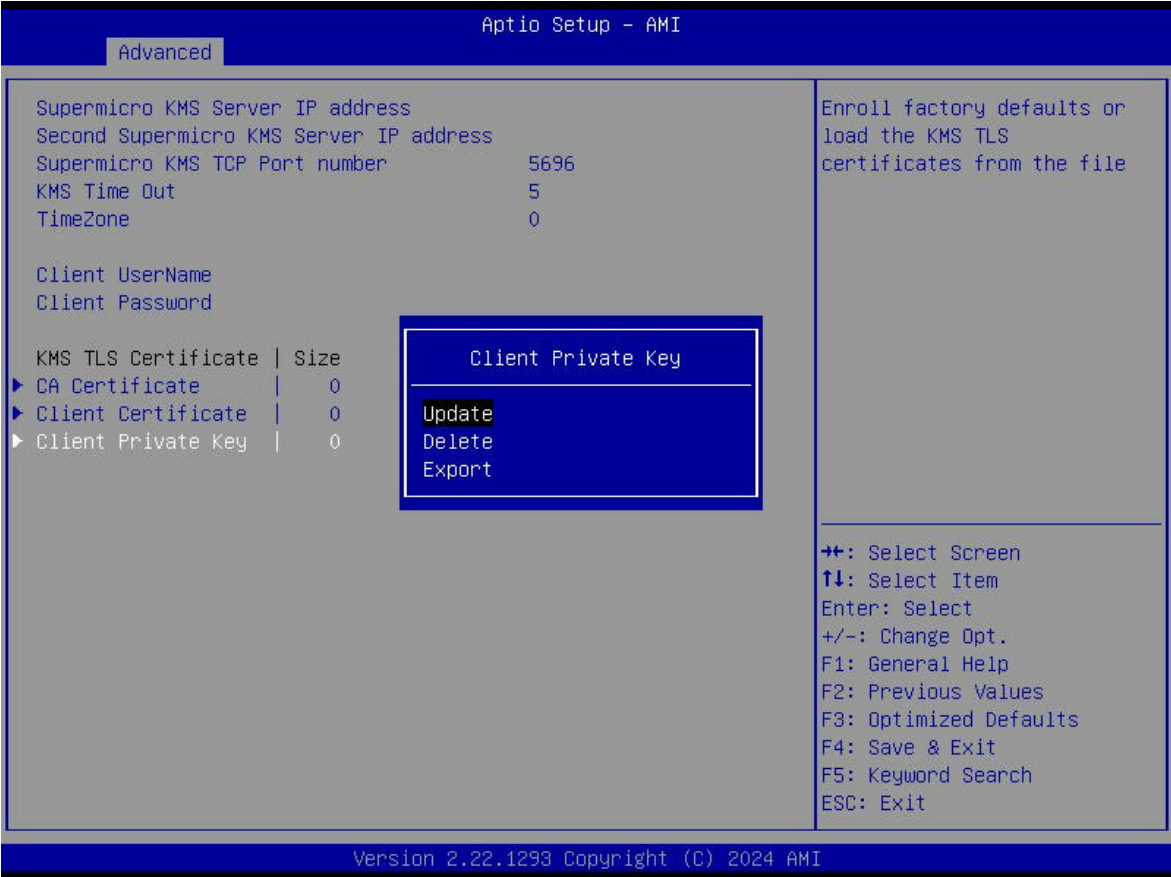

**Private Key Password (Available when "Client Private Key" above has been set)**

Use this feature to change the password for the client private key.

## Super-Guardians Configuration Menu

### ► Super-Guardians Configuration

#### Super-Guardians Protection Policy

Use this feature to enable the Super-Guardians Protection Policy. The options are **Storage**, **System**, and **System and Storage**. Set this feature to **Storage** to protect and have secure access to Trusted Computing Group (TCG) NVMe devices with the Authentication-Key (AK). Set this feature to **System** to protect and have secure access to your system/motherboard with the AK. Set this feature to **System and Storage** to protect and have secure access to your system/motherboard/storage devices with the AK.

#### **KMS Security Policy (Available when "TPM Security Policy" and "USB Security Policy" are set to Disabled)**

Set this feature to **Enabled** to enable the KMS Security Policy. When this feature has not previously been set to **Enabled**, the options are **Disabled** and **Enabled**. Changes take effect after you save settings and reboot the system.

When this feature has previously been set to **Enabled**, the options are **Enabled**, **Reset**, and **Key Rotation**. Set this feature to **Key Rotation** to obtain an existing AK from the KMS server and create a new AK. To disable the KMS Security Policy, set this feature to **Reset**. When this feature is set to **Reset**, the system and TCG NVMe devices chosen in "Super-Guardians Protection Policy" will be in the unprotected mode.

#### **Notes:**

- Be sure that the KMS server is ready before configuring this feature.
- Use the professional KMS server solutions (e.g., Thales Server) or the Supermicro PyKMIP Software Package to establish the KMS server.

#### **KMS Server Retry Count (Available when "TPM Security Policy" and "USB Security Policy" are set to Disabled)**

Use this feature to specify how many times the system will attempt reconnecting to the KMS server. The valid range is 0–10. Press the <+> or <-> key on your keyboard to change the value. The default setting is **5**. If the value is 0, the system will retry infinitely.

#### **TPM Security Policy (Available when "KMS Security Policy" and "USB Security Policy" are set to Disabled)**

Set this feature to **Enabled** to enable the TPM Security Policy. When this feature has not previously been set to **Enabled**, the options are **Disabled** and **Enabled**. Changes take effect after you save settings and reboot the system.

When this feature has previously been set to Enabled, the options are **Enabled** and Reset. To disable the TPM Security Policy, set this feature to Reset. When this feature is set to reset, the system and TCG NVMe devices chosen in "Super-Guardians Protection Policy" will be in the unprotected mode.

**Note:** Be sure to install a TPM 2.0 device to your system before configuring this feature.

**Load Authentication-Key (Available when "KMS Security Policy," "TPM Security Policy," and "USB Security Policy" are set to Disabled)**

The options are **Disabled** and Enabled. Set this feature to Enabled. Changes take effect after you save settings and reboot the system. While booting, the BIOS will automatically load the Authentication-Key (filename: TPMAuth.bin) from the USB flash drive. Afterwards, the default setting will be set to Disabled by the BIOS.

**Notes:**

- Be sure to connect a USB flash drive with the Authentication-Key (filename: TPMAuth.bin) to your system before the system reboots.
- Be sure to save the Authentication-Key (filename: TPMAuth.bin) to the USB flash drive and have a backup. Please load the Authentication-Key (filename: TPMAuth.bin) after installing a TPM device. Otherwise, the TPM function can not work properly.

**USB Security Policy (Available when "KMS Security Policy" and "TPM Security Policy" are set to Disabled)**

Use this feature to enable the USB Security Policy. The options are **Disabled** and Enabled. Set this feature to Enabled. Changes take effect after you save settings and reboot the system. Connect a USB flash drive to your system before the system reboot. While booting, the BIOS will automatically create the USB Authentication-Key (filename: USBAuth.bin) and save it to the USB flash drive.

When this feature has been previously set to Enabled, the options are **Enabled** and Reset. To disable the USB Security Policy, set this feature to Reset. When this feature is set to Reset, the system and TCG NVMe devices chosen in "Super-Guardians Protection Policy" will be in the unprotected mode.

**Note:** Be sure to connect a USB flash drive to your system before configuring this feature. Save the USB Authentication-Key (filename: USBAuth.bin) to the USB flash drive and keep a backup.

---

---

## System Diagnostics Configuration

### Launch System Diagnostics

Use this feature to run hardware tests that check the health of system components and help identify any issues. The options are **Disabled** and Launch Once.

## TLS Authenticate Configuration Menu

### ► Server CA Configuration

This feature allows you to configure the client certificate that is to be used by the server.

#### ► Enroll Certification

This feature allows you to enroll the certificate in the system.

#### ► Commit Changes and Exit

Use this feature to save all changes and exit TLS settings.

#### ► Discard Changes and Exit

Use this feature to discard all changes and exit TLS settings.

#### ► Delete Certification

This feature is used to remove the selected TLS certificates that are no longer needed or valid.

### ► Client Certification Configuration

Use this feature to manage the TLS certificates used to authenticate remote clients connecting to your system. Add, view, or delete client certificates as needed.

## Driver Health Menu

### ► Driver Health

This feature displays the health information of the drivers installed in your system, including LAN controllers, as detected by the BIOS. Select one and press <Enter> to see the details.

**Note:** This section is provided for reference only, for the driver health status will differ depending on the drivers installed in your system. It's also based on your system configuration and the environment that your system is operating in.

## 4.4 BMC

Use this menu to configure Baseboard Management Console (BMC) settings.



**Figure 4-3. BMC Screen**

### BMC Firmware Revision

This feature indicates the BMC firmware revision used in this system.

### BMC STATUS

This feature indicates the status of the BMC firmware installed in this system.

## System Event Log Menu

### ► System Event Log

**Note:** All values changed in this submenu do not take effect until computer is restarted.

## SEL Components

Select Enabled to enable all system event logging upon system boot. The options are Disabled and **Enabled**.

## Erasing Settings

### Erase SEL (Available when "SEL Components" is set to Enabled)

Select (Yes, On next reset) to erase all system event logs upon next system boot. Select (Yes, On every reset) to erase all system event logs upon each system reboot. Select No to keep all system event logs after each system reboot. The options are **No**, (Yes, On next reset), and (Yes, On every reset).

### When SEL is Full (Available when "SEL Components" is set to Enabled)

This feature defines what the BIOS should do when the system event log is full. Select Erase Immediately to erase all events in the log when the system event log is full. The options are **Do Nothing** and Erase Immediately.

## BMC Network Configuration Menu

### ► BMC Network Configuration

#### Update BMC LAN Configuration

Select Yes for the BIOS to implement all IP/MAC address changes upon next system boot. The options are **No** and Yes.

\*\*\*\*\*

#### Configure IPv4 Support

\*\*\*\*\*

#### BMC LAN Selection

This feature displays the type of the BMC LAN.

#### BMC Network Link Status:

This feature displays the status of the BMC network link for this system.

#### Configuration Address Source (Available when "Update BMC LAN Configuration" is set to Yes)

Use this feature to select the source of the IPv4 connection. If Static is selected, note the IP address of the IPv4 connection and enter it to the system manually in the field. If DHCP is selected, the BIOS will search for a Dynamic Host Configuration Protocol (DHCP) server in the network that is attached to and request the next available IP address for this computer. The options are Static and **DHCP**.

### **Station IP Address**

This feature displays the Station IP address in decimal and in dotted quad form (i.e., 172.29.176.131). It is available for configuration when "Configuration Address Source" above is set to Static.

### **Subnet Mask**

This feature displays the sub-network that this computer belongs to. It is available for configuration when "Configuration Address Source" above is set to Static.

### **Station MAC Address**

This feature displays the Station MAC address for this computer. MAC addresses are six two-digit hexadecimal numbers.

### **Gateway IP Address**

This feature displays the Gateway IP address for this computer. This should be in decimal and in dotted quad form (i.e., 172.29.0.1). It is available for configuration when "Configuration Address Source" above is set to Static.

\*\*\*\*\*

### **Configure IPv6 Support**

\*\*\*\*\*

### **IPv6 Address Status**

This feature displays the status of the IPv6 address.

### **IPv6 Support (Available when "Update BMC LAN Configuration" is set to Yes)**

Use this feature to enable IPv6 support. The options are **Enabled** and Disabled.

### **Configuration Address Source (Available when "IPv6 Support" is set to Enabled)**

Use this feature to select the source of the IPv6 connection. If Static Configuration is selected, note the IP address of IPv6 connection and enter it to the system manually in the field. If the other two options are selected, the BIOS will search for a DHCP server in the network that is attached to and request the next available IP address for this computer. The options are Static Configuration, **DHCPv6 Stateless**, and DHCPv6 Stateful.

### **IPv6 Address ("Static," "DHCPv6 Stateless," or "DHCPv6 Stateful," depending on the option you selected for "Configuration Address Source" above)**

This feature displays the station IPv6 address. It is available for configuration when "Configuration Address Source" above is set to Static Configuration.

**Prefix Length**

This feature displays the prefix length. It is available for configuration when "Configuration Address Source" above is set to Static Configuration.

**Gateway IP**

This feature displays the IPv6 gateway IP address. It is available for configuration when "Configuration Address Source" above is set to Static Configuration.

**Advanced Settings (Available when "Configuration Address Source" is set to DHCPv6 Stateless)**

Use this feature to set the DNS server IP. The default setting allows this system to obtain the DNS server IP automatically. The options are **Auto obtain DNS server IP** and Manually obtain DNS server IP.

**Preferred DNS server IP (Available when "Advanced Settings" above is set to Manually obtain DNS server IP)**

This feature displays the preferred DNS server IP. It can be configured via Redfish.

**Alternative DNS server IP (Available when "Advanced Settings" above is set to Manually obtain DNS server IP)**

This feature displays the alternative DNS server IP. It can be configured via Redfish.

\*\*\*\*\*

**Configure VLAN Support**

\*\*\*\*\*

**VLAN Support (Available when "Update BMC LAN Configuration" is set to Yes)**

Use this feature to enable the virtual LAN (VLAN) support. The options are Enabled and Disabled.

**VLAN ID (Available when "VLAN Support" is set to Enabled)**

Use this feature to create a new VLAN ID. The valid range is 1–4094. The default setting is 1.

## 4.5 Event Logs

Use this menu to configure Event Logs settings.

**Note:** After making any changes in this section, please be sure to reboot the system for the changes to take effect.

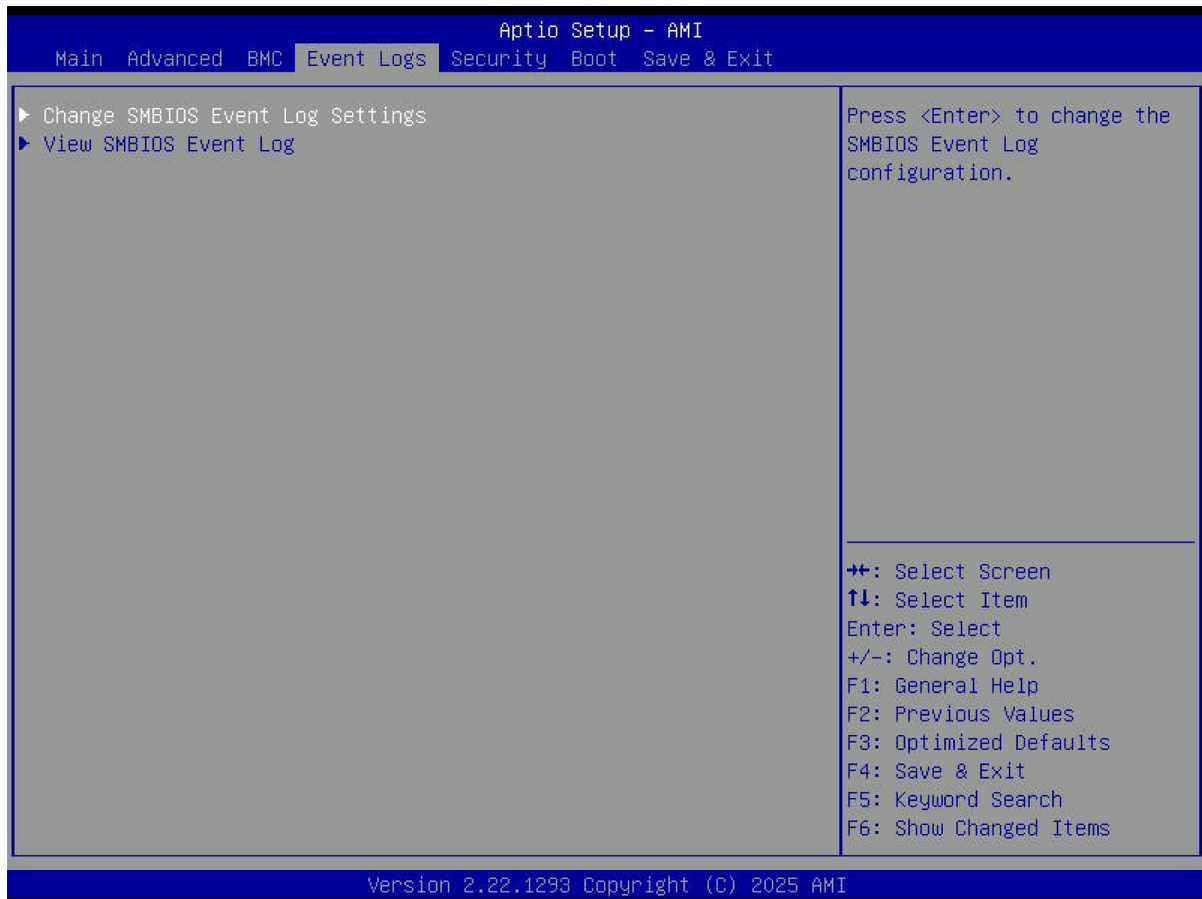

**Figure 4-4. Event Logs Screen**

### ► Change SMBIOS Event Log Settings

**Note:** Reboot the system for the changes in this section to take effect.

#### Enabling/Disabling Options

##### SMBIOS Event Log

Select Enabled to enable System Management BIOS (SMBIOS) Event Logging during system boot. The options are Disabled and **Enabled**.

## Erasing Settings

### Erase Event Log (Available when "SMBIOS Event Log" is set to Enabled)

Select No to keep the event log without erasing it upon next system bootup. Select (Yes, Next reset) to erase the event log upon next system reboot. The options are **No**, (Yes, Next reset), and (Yes, Every reset).

### When Log is Full (Available when "SMBIOS Event Log" is set to Enabled)

Select Erase Immediately to immediately erase all errors in the SMBIOS event log when the event log is full. Select Do Nothing for the system to do nothing when the SMBIOS event log is full. The options are **Do Nothing** and Erase Immediately.

## SMBIOS Event Log Standard Settings

### Log System Boot Event (Available when "SMBIOS Event Log" is set to Enabled)

Select Enabled to log system boot events. The options are Enabled and **Disabled**.

### MECI (Available when "SMBIOS Event Log" is set to Enabled)

Enter the increment value for the multiple event counter. Enter a number between 1 and 255. The default setting is **1**. (MECI is the abbreviation for Multiple Event Count Increment.)

### METW (Available when "SMBIOS Event Log" is set to Enabled)

Use this feature to determine how long (in minutes) should the multiple event counter wait before generating a new event log. Enter a number between 0 and 99. The default value is **60**. (METW is the abbreviation for Multiple Event Count Time Window.)

### ► View SMBIOS Event Log

Use this feature to view the event in the system event log. Select this feature and press <Enter> to view the status of an event in the log. The following information is displayed: DATE / TIME / ERROR CODE / SEVERITY.

## 4.6 Security

Use this menu to configure the following security settings for the system.

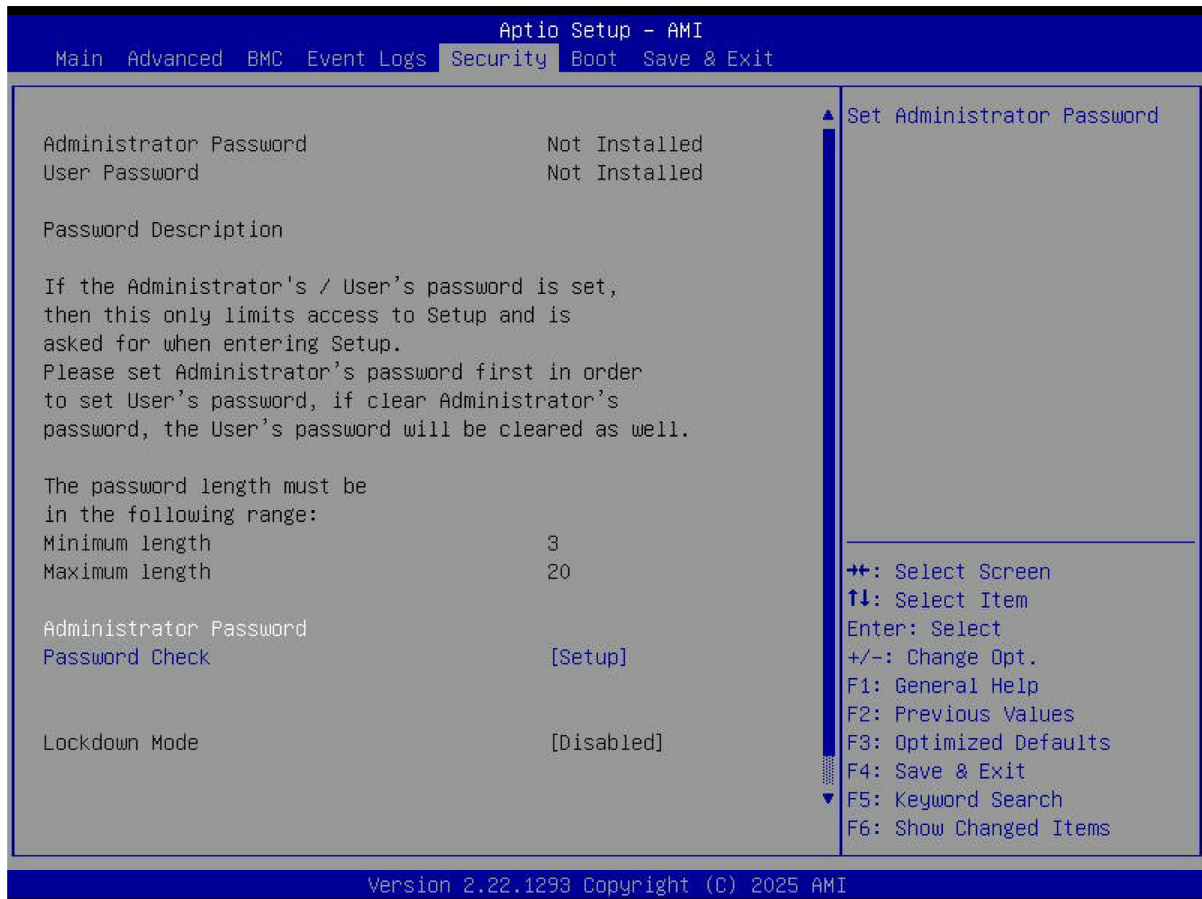

**Figure 4-5. Security Screen**

### **Disable Block Sid and Freeze Lock (Available when your storage devices support TCG)**

Select Enabled to allow SID authentication to be performed in TCG storage devices. The options are **Disabled** and Enabled.

The following information is displayed:

- Administrator Password
- User Password
- Password Description

### **Administrator Password**

This feature indicates if an administrator password has been installed. Use this feature to set the administrator password, which is required to enter the BIOS Setup utility. The length of the password can be between three and 20 characters long.

**User Password (Available when "Administrator Password" has been set)**

This feature indicates if a user password has been installed. Use this feature to set the user password which is required to enter the BIOS Setup utility. The length of the password can be between three and 20 characters long.

**Password Check**

Select Setup for the system to check for a password upon entering the BIOS Setup utility. Select Always for the system to check for the passwords needed at bootup and upon entering the BIOS Setup utility. The options are **Setup** and Always.

**Hard Drive Security Frozen**

Select Enabled to freeze the Lock Security feature for HDD to protect key data in hard drives from being altered. The options are **Disabled** and Enabled.

**Lockdown Mode (Available when the DCMS key is activated)**

Select Enabled to support the Lockdown Mode, which prevents the existing data or keys stored in the system from being altered or changed in an effort to preserve system integrity and security. The options are **Disabled** and Enabled.

**► Secure Boot**

The following information is displayed:

- System Mode
- Secure Boot

**Note:** For detailed instructions on configuring Security Boot settings, refer to the Security Boot Configuration User's Guide at <https://www.supermicro.com/support/manuals>.

**Secure Boot**

Select Enabled to configure Secure Boot settings. The options are **Disabled** and Enabled.

**CSM Support**

Select Enabled to support the EFI Compatibility Support Module (CSM), which provides compatibility support for traditional legacy BIOS for system boot. The options are **Disabled** and Enabled.

**Secure Boot Mode**

Use this feature to select the desired secure boot mode for the system. The options are Standard and **Custom**.

### ▶ Enter Audit Mode

Select Ok to enter the Audit Mode workflow. It will result in erasing the Platform Key (PK) variables and resetting the system to the Setup/Audit Mode.

**Note:** This submenu is available when "Secure Boot Mode" is set to Custom.

### ▶ Key Management

The following information is displayed:

- Vendor Keys

**Note:** This submenu is available when "Secure Boot Mode" is set to Custom.

### Provision Factory Defaults

Select Enabled to install provision factory default settings after a platform reset while the system is in the Setup Mode. The options are **Disabled** and Enabled.

### ▶ Restore Factory Keys

Select Yes to restore manufacturer default keys to ensure system security. The options are **Yes** and No. Selecting Yes will reset system to the User Mode.

**Note:** This submenu is available when any secure keys have been installed.

### ▶ Reset To Setup Mode

This feature resets the system to the Setup Mode. The options are **Yes** and No.

**Note:** This submenu is available when any secure keys have been installed.

### ▶ Enroll Efi Image

This feature allows the Efi image to run in the secure boot mode and enroll the SHA256 Hash certificate of a PE image into the Authorized Signature Database (DB).

### ▶ Export Secure Boot Variables

This feature exports the NVRAM contents of secure boot variables to a storage device. The options are **Yes** and No.

**Note:** This submenu is available when any secure keys have been installed.

## Secure Boot variable / Size / Keys / Key Source

### ► Platform Key (PK)

Use this feature to enter and configure a set of values to be used as platform firmware keys for the system. These values also indicate the sizes, key numbers, and the sources of the authorized signatures. Select Update to update the platform key.

### ► Key Exchange Keys (KEK)

Use this feature to enter and configure a set of values to be used as Key Exchange Keys for the system. These values also indicate the sizes, key numbers, and the sources of the authorized signatures. Select Update to update the Key Exchange Keys. Select Append to append the Key Exchange Keys.

### ► Authorized Signatures (db)

Use this feature to enter and configure a set of values to be used as Authorized Signatures for the system. These values also indicate the sizes, key numbers, and sources of the authorized signatures. Select Update to update the Authorized Signatures. Select Append to append the new Authorized Signatures.

### ► Forbidden Signatures (dbx)

Use this feature to enter and configure a set of values to be used as Forbidden Signatures for the system. These values also indicate sizes, key numbers, and key sources of the forbidden signatures. Select Update to update the Forbidden Signatures. Select Append to append the Forbidden Signature.

### ► Authorized TimeStamps (dbt)

Use this feature to set and save the timestamps for the Authorized Signatures, which will indicate the time when these signatures are entered into the system. These values also indicate sizes, keys, and key sources of the authorized timestamps. Select Update to update the Authorized TimeStamps. Select Append to append the Authorized TimeStamps.

### ► **OsRecovery Signatures (dbr)**

Use this feature to set and save the Authorized Signatures used for OS recovery. Select Update to update the OsRecovery Signatures. These values also indicate sizes, keys, and key sources of the OsRecovery Signatures. Select Append to append the OsRecovery Signatures.

## 4.7 Boot

Use this menu to configure Boot settings.

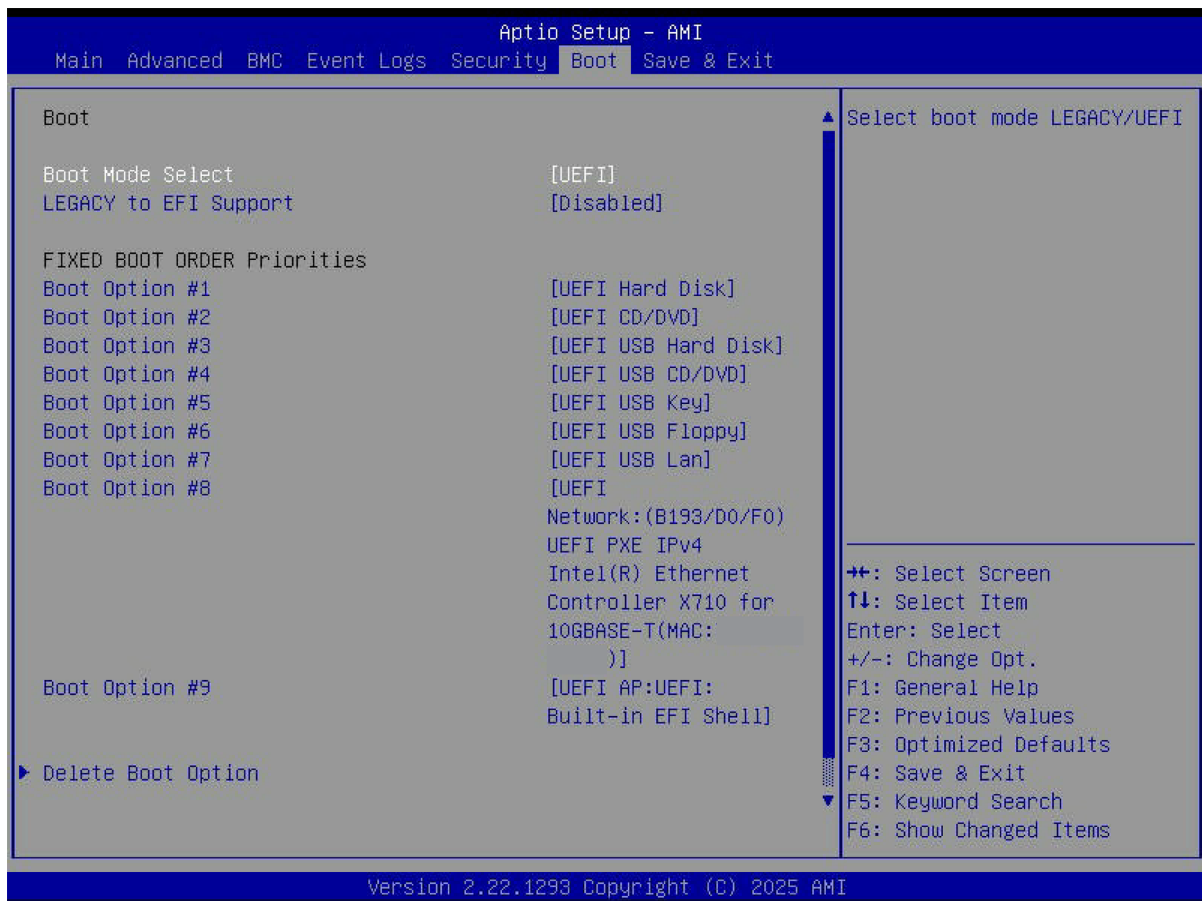

**Figure 4-6. Boot Screen**

### FIXED BOOT ORDER Priorities

Use this feature to prioritize the order of a bootable device from which the system will boot. Press <Enter> on each item sequentially to select the device.

- Boot Option #1 – Boot Option #9

#### ► Add New Boot Option

Use this feature to add a new boot option to the boot priority features for system boot.

**Note:** This submenu is available when any storage device is detected by the BIOS.

#### Add boot option

Use this feature to specify the name for the new boot option.

**Path for boot option**

Use this feature to enter the path for the new boot option in the format fsx:\path\filename.efi.

**Boot option File Path**

Use this feature to specify the file path for the new boot option.

**Create**

After setting the name and the file path for the boot option, press <Enter> to create the new boot option in the boot priority list.

**▶ Delete Boot Option**

Use this feature to select a boot device to delete from the boot priority list.

**Delete Boot Option**

Use this feature to remove an EFI boot option from the boot priority list.

**▶ UEFI NETWORK Drive BBS Priorities**

Use this feature to set the system boot order of detected devices.

**▶ UEFI Application Boot Priorities**

Use this feature to set the system boot order of detected devices.

**▶ UEFI USB Key Drive BBS Priorities**

Use this feature to set the system boot order of detected devices.

**▶ UEFI Hard Disk Drive BBS Priorities**

Use this feature to set the system boot order of detected devices.

## 4.8 Save & Exit

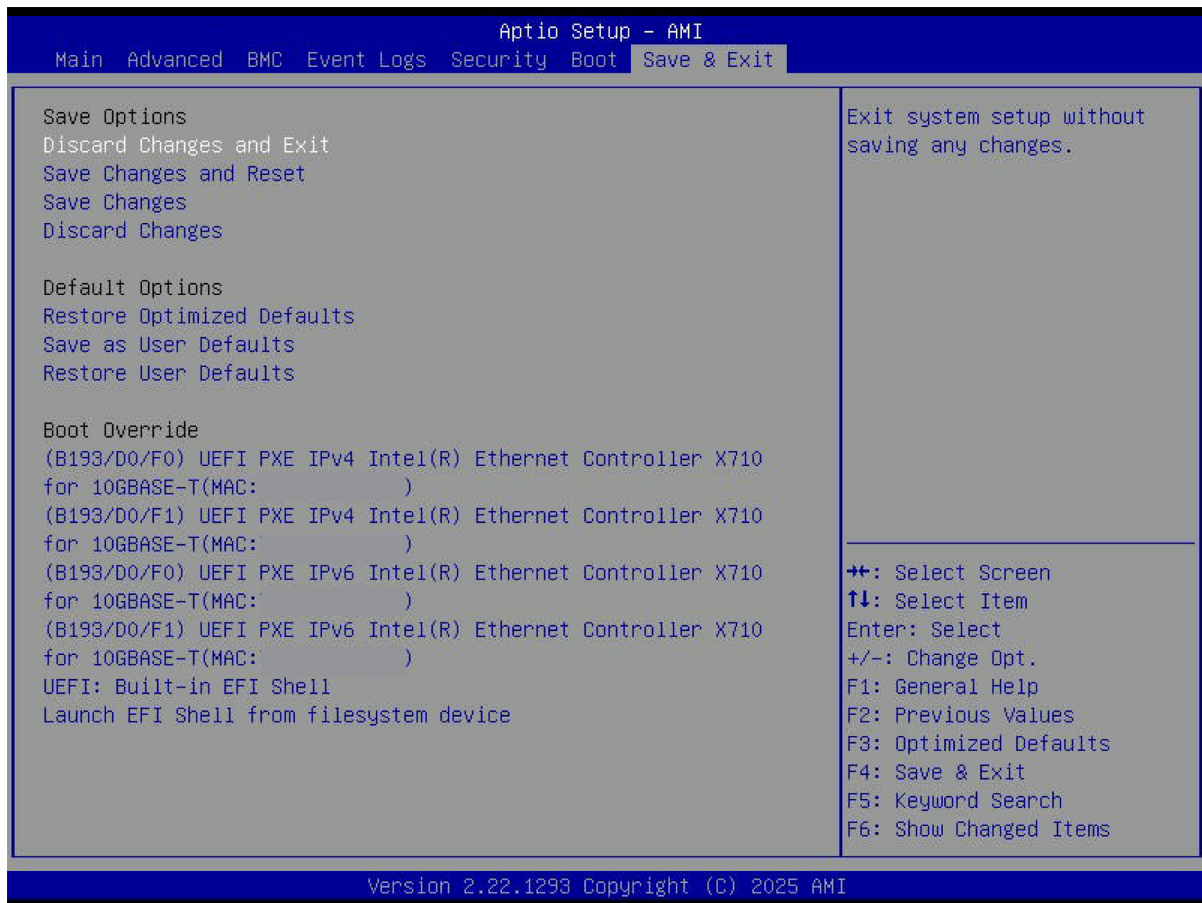

**Figure 4-7. Save & Exit Tab**

### Save Options

#### Discard Changes and Exit

Use this feature to exit from the BIOS Setup utility without making any permanent changes to the system configuration and reboot the computer.

#### Save Changes and Reset

On completing the system configuration changes, use this feature to exit the BIOS Setup utility and reboot the computer for the new system configuration parameters to take effect.

#### Save Changes

On completing the system configuration changes, use this feature to save all changes made. This will not reset (reboot) the system.

**Discard Changes**

Select this feature and press <Enter> to discard all changes made and return to the BIOS Setup utility.

**Default Options****Restore Optimized Defaults**

Select this feature and press <Enter> to load manufacturer optimized default settings, which are intended for maximum system performance but not for maximum stability.

**Note:** After pressing <Enter>, reboot the system for the changes to take effect, which ensures that this system has the optimized default settings.

**Save as User Defaults**

Select this feature and press <Enter> to save all changes as the default values specified to the BIOS Setup utility for future use.

**Restore User Defaults**

Select this feature and press <Enter> to retrieve user-defined default settings that have been saved previously.

**Boot Override**

**Note:** Use this section to override the Boot priorities sequence in the Boot menu, and immediately boot the system with a device specified here instead of the one specified in the boot list. This is a one-time boot override.

## Appendix A:

### Software

After the H14SST-GE motherboard has been installed, you can install the Operating System (OS), configure RAID settings, and install the drivers.

#### Microsoft Windows OS Installation

If you will be using RAID, you must configure RAID settings before installing the Windows OS and the RAID driver. Refer to the RAID Configuration User Guides posted on our website at <https://www.supermicro.com/support/manuals>.

##### Installing the OS

1. Create a method to access the Microsoft Windows installation ISO file. That can be a USB flash or media drive, or the BMC KVM console.
2. Retrieve the proper drivers. Go to the Supermicro web page for your motherboard and click on "Download the Latest Drivers and Utilities," select the proper driver, and copy it to a USB flash drive.
3. Boot from a bootable device with Windows OS installation. You can see a bootable device list by pressing <F11> during the system bootup.

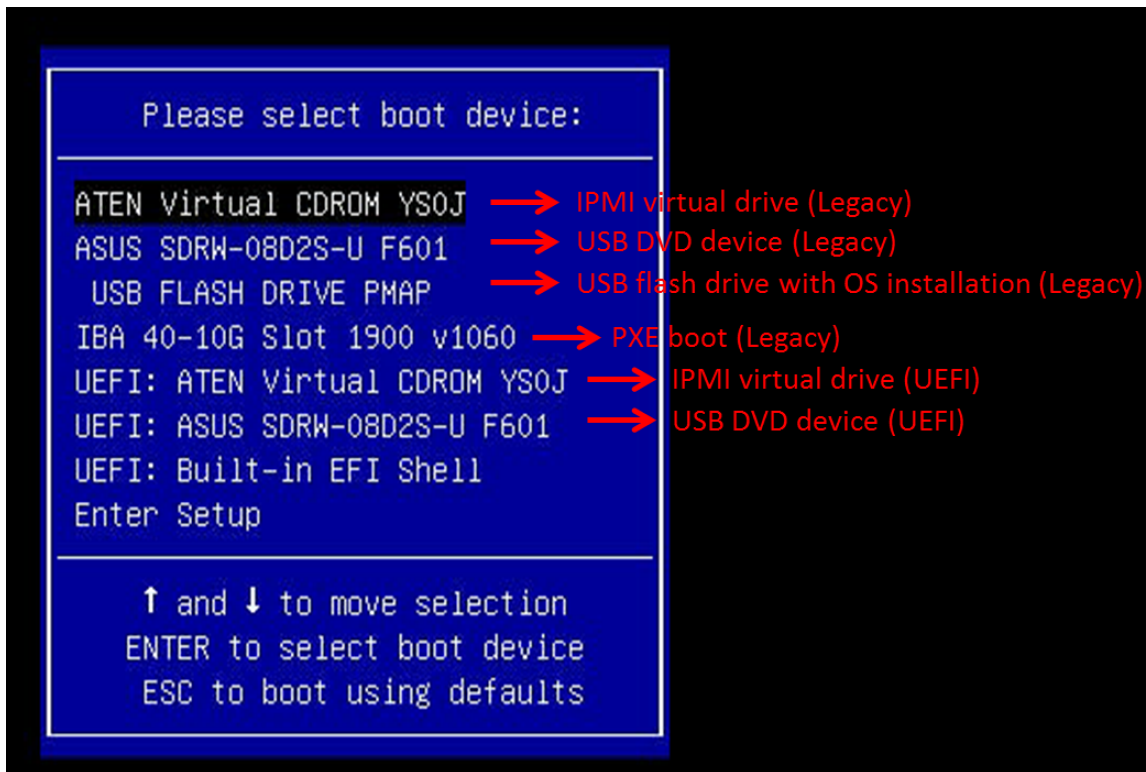

**Figure A-1. Selecting the Boot Device**

4. During Windows Setup, continue to the dialog box where you select the drives on which to install Windows. If the disk you want to use is not listed, click on the “Load driver” link at the bottom left corner.

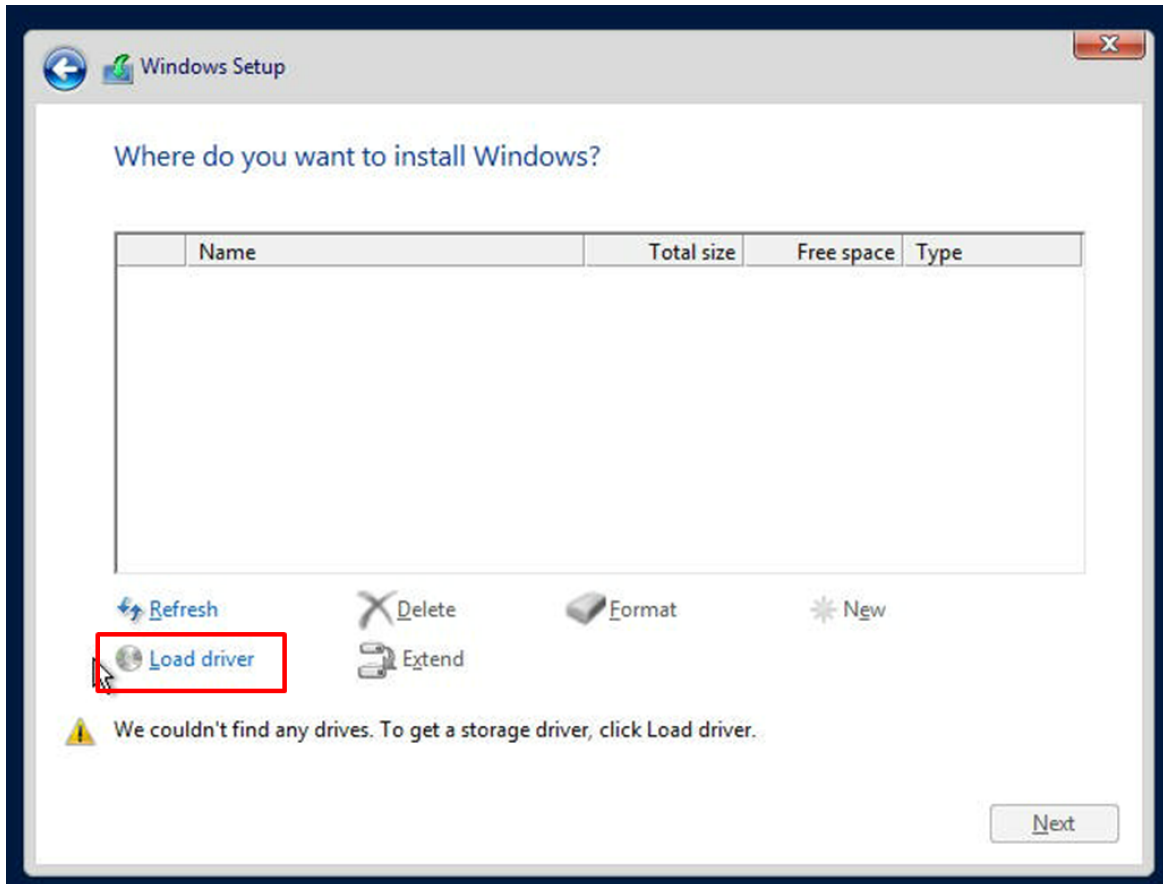

**Figure A-2. Loading the Driver Link**

To load the driver, browse the USB flash drive for the proper driver files.

5. Once all devices are specified, continue with the installation.
6. After the Windows OS installation has completed, the system will automatically reboot multiple times for system updates.

## Driver Installation

The Supermicro website contains drivers and utilities for your system at the following page:

<https://www.supermicro.com/wdl>.

Some of these drivers and utilities must be installed, such as the chipset driver. After accessing the website, go into the CDR\_Images (in the parent directory of the above link) and locate the ISO file for your motherboard. Download this file to a USB flash or media drive. You may also use a utility to extract the ISO file if preferred.

Another option is to go to the Supermicro website at <https://www.supermicro.com>. Find the product page for your motherboard and download the latest drivers and utilities. Insert the flash drive or disk, and the screenshot shown below should appear.

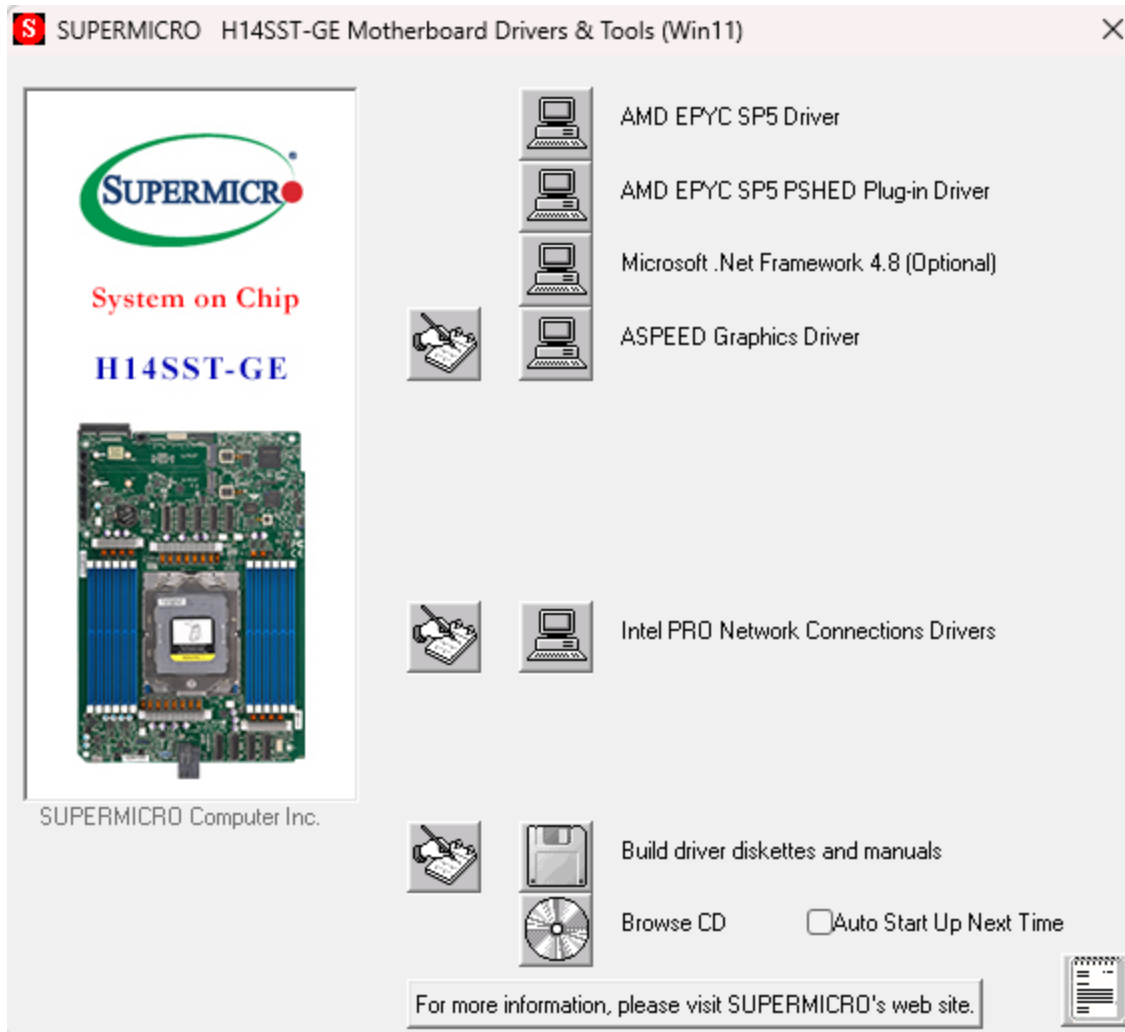

**Figure A-3. Driver & Tools Installation Screen**

**Note:** Click the icons showing a hand writing on paper to view the readme files for each item. Click the computer icons to the right of these items to install each item (from top to bottom) one at a time. After installing each item, you must reboot the system before moving on to the next item on the list. The bottom icon with a CD on it allows you to view the entire contents.

## BMC

The H14SST-GE motherboard provides remote access, monitoring, and management through the baseboard management controller (BMC) and other management controllers distributed among different system modules. There are several BIOS settings that are related to BMC. For general documentation and information on BMC, visit our website at the following page:

<https://www.supermicro.com/en/solutions/management-software/bmc-resources>

## BMC ADMIN User Password

For security, each system is assigned a unique default BMC password for the ADMIN user. The password can be found on a sticker on the motherboard and a sticker on the chassis, for Supermicro chassis. The sticker also displays the BMC MAC address. If necessary, the password can be reset using the Supermicro IPMICFG tool.



**Figure A-4. BMC Password Label**

## Appendix B:

# Standardized Warning Statements

The following statements are industry standard warnings, provided to warn the user of situations which have the potential for bodily injury. Should you have questions or experience difficulty, contact Supermicro's Technical Support department for assistance. Only certified technicians should attempt to install or configure components.

Read this section in its entirety before installing or configuring components in the Supermicro H14SST-GE motherboard.

These warnings may also be found on our website at the following page:

[https://www.supermicro.com/about/policies/safety\\_information.cfm](https://www.supermicro.com/about/policies/safety_information.cfm)

## Battery Handling



**CAUTION** There is risk of explosion if the battery is replaced by an incorrect type. Replace the battery only with the same or equivalent type recommended by the manufacturer. Dispose of used batteries according to the manufacturer's instructions.

警告!

バッテリーを間違ったタイプに交換すると爆発の危険があります。交換する電池はメーカーが推奨する型、または同等のものを使用下さい。使用済電池は製造元の指示に従って処分して下さい。

警告!

如果更换的电池类型不正确。请只使用同类电池或制造商推荐的功能相当的电池更换原有电池。请按制造商的说明处理废旧电池。

警告!

如果更換的電池類型不正確。請使用製造商建議之相同或功能相當的電池更換原有電池。請按照製造商的說明指示處理廢棄舊電池。

**WARNUNG!**

Es besteht Explosionsgefahr, wenn die Batterie durch einen falschen Typ ersetzt wird. Ersetzen Sie die Batterie nur durch den gleichen oder vom Hersteller empfohlenen Batterietyp. Entsorgen Sie die benutzten Batterien nach den Anweisungen des Herstellers.

**¡ADVERTENCIA!**

Existe riesgo de explosión si la batería se reemplaza por un tipo incorrecto. Reemplazar la batería exclusivamente con el mismo tipo o el equivalente recomendado por el fabricante. Desechar las baterías gastadas según las instrucciones del fabricante.

**ATTENTION!**

Il existe un risque d'explosion si la batterie est remplacée par un type incorrect. Ne la remplacer que par une pile de type semblable ou équivalent, recommandée par le fabricant. Jeter les piles usagées conformément aux instructions du fabricant.

**אזהרה!**

קיימת סכנת פיצוץ אם הסוללה תוחלף בסוג שגוי. יש להחליף את הסוללה בסוג התואם מחברת יצרן מומלצת. סילוק הסוללות המשומשות יש לבצע לפי הוראות היצרן.

**تحذير!**

هناك خطر الانفجار إذا تم استبدال البطارية بنوع غير صحيح.

**اسحبذال البطارية**

فقط بنفس النوع أو ما يعادلها مما أوصت به الشركة المصنعة

جخلص من البطاريات المسحمة وفقاً لتعليمات الشركة الصانعة

**경고!**

배터리를 잘못된 종류로 교체하면 폭발의 위험이 있습니다. 기존 배터리와 동일하거나 제조사에서 권장하는 동등한 종류의 배터리로만 교체해야 합니다. 제조사의 안내에 따라 사용된 배터리를 처리하여 주십시오.

**WAARSCHUWING!**

Er bestaat explosiegevaar als de batterij wordt vervangen door een verkeerd type. Vervang de batterij slechts met hetzelfde of een equivalent type die door de fabrikant aanbevolen wordt. Gebruikte batterijen dienen overeenkomstig fabrieksvoorschriften afgevoerd te worden.

**Product Disposal**

**Warning!** Ultimate disposal of this product should be handled according to all national laws and regulations.

**警告!**

この製品を廃棄処分する場合、国の関係する全ての法律・条例に従い処理する必要があります。

**警告!**

本产品的废弃处理应根据所有国家的法律和规章进行。

**警告!**

本產品的廢棄處理應根據所有國家的法律和規章進行。

**Warnung!**

Die Entsorgung dieses Produkts sollte gemäß allen Bestimmungen und Gesetzen des Landes erfolgen.

**¡Advertencia!**

Al deshacerse por completo de este producto debe seguir todas las leyes y reglamentos nacionales.

**Attention!**

La mise au rebut ou le recyclage de ce produit sont généralement soumis à des lois et/ou directives de respect de l'environnement. Renseignez-vous auprès de l'organisme compétent.

אזהרה!

סילוק סופי של מוצר זה חייב להיות בהתאם להנחיות וחוקי המדינה.

تحذير!

عند التخلص النهائي من هذا المنتج ينبغي التعامل معه وفقا لجميع القوانين واللوائح الوطنية

경고!

이 제품은 해당 국가의 관련 법규 및 규정에 따라 폐기되어야 합니다.

Waarschuwing!

De uiteindelijke verwijdering van dit product dient te geschieden in overeenstemming met alle nationale wetten en reglementen.