

# SUPERO®

H8DMT+  
H8DMT-INF+

## USER'S MANUAL

Revision 1.0b

---

The information in this User's Manual has been carefully reviewed and is believed to be accurate. The vendor assumes no responsibility for any inaccuracies that may be contained in this document, makes no commitment to update or to keep current the information in this manual, or to notify any person or organization of the updates. **Please Note: For the most up-to-date version of this manual, please see our web site at [www.supermicro.com](http://www.supermicro.com).**

Super Micro Computer, Inc. ("Supermicro") reserves the right to make changes to the product described in this manual at any time and without notice. This product, including software, if any, and documentation may not, in whole or in part, be copied, photocopied, reproduced, translated or reduced to any medium or machine without prior written consent.

IN NO EVENT WILL SUPERMICRO BE LIABLE FOR DIRECT, INDIRECT, SPECIAL, INCIDENTAL, SPECULATIVE OR CONSEQUENTIAL DAMAGES ARISING FROM THE USE OR INABILITY TO USE THIS PRODUCT OR DOCUMENTATION, EVEN IF ADVISED OF THE POSSIBILITY OF SUCH DAMAGES. IN PARTICULAR, SUPERMICRO SHALL NOT HAVE LIABILITY FOR ANY HARDWARE, SOFTWARE, OR DATA STORED OR USED WITH THE PRODUCT, INCLUDING THE COSTS OF REPAIRING, REPLACING, INTEGRATING, INSTALLING OR RECOVERING SUCH HARDWARE, SOFTWARE, OR DATA.

Any disputes arising between manufacturer and customer shall be governed by the laws of Santa Clara County in the State of California, USA. The State of California, County of Santa Clara shall be the exclusive venue for the resolution of any such disputes. Super Micro's total liability for all claims will not exceed the price paid for the hardware product.

FCC Statement: This equipment has been tested and found to comply with the limits for a Class A digital device pursuant to Part 15 of the FCC Rules. These limits are designed to provide reasonable protection against harmful interference when the equipment is operated in a commercial environment. This equipment generates, uses, and can radiate radio frequency energy and, if not installed and used in accordance with the manufacturer's instruction manual, may cause harmful interference with radio communications. Operation of this equipment in a residential area is likely to cause harmful interference, in which case you will be required to correct the interference at your own expense.

California Best Management Practices Regulations for Perchlorate Materials: This Perchlorate warning applies only to products containing CR (Manganese Dioxide) Lithium coin cells. "Perchlorate Material-special handling may apply. See [www.dtsc.ca.gov/hazardouswaste/perchlorate](http://www.dtsc.ca.gov/hazardouswaste/perchlorate)"

---

**WARNING: Handling of lead solder materials used in this product may expose you to lead, a chemical known to the State of California to cause birth defects and other reproductive harm.**

---

Manual Revision 1.0b  
Release Date: December 24, 2008

Unless you request and receive written permission from SUPER MICRO COMPUTER, you may not copy any part of this document.

Information in this document is subject to change without notice. Other products and companies referred to herein are trademarks or registered trademarks of their respective companies or mark holders.

Copyright © 2008 by SUPER MICRO COMPUTER INC.  
All rights reserved.

**Printed in the United States of America**

## Preface

### About This Manual

This manual is written for system integrators, PC technicians and knowledgeable PC users. It provides information for the installation and use of the H8DMT+/H8DMT-INF+ motherboard. The H8DMT+/H8DMT-INF+ is based on the nVidia® MCP55-V Pro chipset and supports dual AMD Socket F type processors and up to 64 GB of DDR2-667/533/400 registered ECC SDRAM.

Please refer to the motherboard specifications pages on our web site for updates on supported processors (<http://www.supermicro.com/aplus/>). This product is intended to be professionally installed.

### Manual Organization

**Chapter 1** includes a checklist of what should be included in your motherboard box, describes the features, specifications and performance of the motherboard and provides detailed information about the chipset.

**Chapter 2** begins with instructions on handling static-sensitive devices. Read this chapter when installing the processor(s) and memory modules and when installing the motherboard in a chassis. Also refer to this chapter to connect the hard disk drives, the various ports, and the power and reset buttons and the system LEDs.

If you encounter any problems, see **Chapter 3**, which describes troubleshooting procedures for the video, the memory and the setup configuration stored in CMOS. For quick reference, a general FAQ (Frequently Asked Questions) section is provided. Instructions are also included for contacting technical support. In addition, you can visit our web site for more detailed information.

**Chapter 4** includes an introduction to BIOS and provides detailed information on running the CMOS Setup utility.

**Appendix A** provides BIOS Error Beep Code Messages.

**Appendix B** lists BIOS POST Checkpoint Codes.

# Table of Contents

## **Chapter 1 Introduction**

1-1	Overview .....	1-1
	Checklist.....	1-1
1-2	Contacting Supermicro.....	1-2
	H8DMT+/H8DMT-INF+ Quick Reference.....	1-5
1-3	Chipset Overview .....	1-9
	MCP55-V Pro Media and Communications Processor.....	1-9
	HyperTransport Technology .....	1-9
1-4	PC Health Monitoring.....	1-10
1-5	Power Configuration Settings.....	1-10
1-6	Power Supply .....	1-12
1-7	Super I/O.....	1-12

## **Chapter 2 Installation**

2-1	Static-Sensitive Devices.....	2-1
	Precautions .....	2-1
	Unpacking .....	2-1
2-2	Processor and Heatsink Installation.....	2-2
2-3	Mounting the Motherboard into a Chassis.....	2-4
2-4	Installing Memory .....	2-4
2-5	I/O Port and Control Panel Connections .....	2-6
	Front Control Panel.....	2-6
2-6	Connector Definitions .....	2-7
	Proprietary Power Connector.....	2-7
	Auxiliary Power Connector.....	2-7
	PW_ON Connector.....	2-7
	Reset Connector .....	2-7
	Overheat/Fan Fail LED (OH).....	2-8
	NIC2 (LAN2) LED.....	2-8
	NIC1 (LAN1) LED.....	2-8
	HDD LED.....	2-8
	Power On LED .....	2-8
	NMI Button .....	2-9
	Universal Serial Bus Ports .....	2-9
	USB Headers .....	2-9
	Power I <sup>2</sup> C .....	2-9
	Serial Ports.....	2-10

---

	Fan Headers.....	2-10
	LAN1/2 (Ethernet Ports).....	2-10
	Overheat LED.....	2-10
	Chassis Intrusion .....	2-10
	Wake-On-LAN .....	2-11
	Wake-On-Ring.....	2-11
	SMBus Header .....	2-11
	SGPIO .....	2-11
2-7	Jumper Settings .....	2-12
	Explanation of Jumpers .....	2-12
	CMOS Clear .....	2-12
	VGA Enable/Disable.....	2-13
	I2C to PCI-Express Slot.....	2-13
	Watch Dog Enable/Disable .....	2-13
	InfiniBand Port Enable/Disable .....	2-13
2-8	Onboard Indicators.....	2-14
	LAN1/LAN2 LEDs.....	2-14
	Power LED .....	2-14
	InfiniBand LED Indicators.....	2-14
2-9	Drive Connections.....	2-15
	SATA Ports .....	2-15
2-10	Enabling SATA RAID.....	2-16
	Serial ATA (SATA).....	2-16
	Installing the OS/SATA Driver .....	2-16
	Building a Driver Diskette.....	2-16
	Enabling SATA RAID in the BIOS .....	2-17
	Using the nVidia RAID Utility .....	2-17
	Installing the OS and Drivers.....	2-17
<b>Chapter 3 Troubleshooting</b>		
3-1	Troubleshooting Procedures .....	3-1
	Before Power On .....	3-1
	No Power .....	3-1
	No Video .....	3-2
	Memory Errors .....	3-2
	Losing the System's Setup Configuration.....	3-2
3-2	Technical Support Procedures .....	3-3
3-3	Frequently Asked Questions .....	3-3
3-4	Returning Merchandise for Service.....	3-4

---

**Chapter 4 BIOS**

4-1	Introduction.....	4-1
4-2	Main Menu .....	4-2
4-3	Advanced Settings Menu .....	4-2
4-4	Boot Menu.....	4-13
4-5	Security Menu .....	4-14
4-6	Exit Menu .....	4-14

**Appendix A BIOS Error Beep Codes**

**Appendix B BIOS POST Checkpoint Codes**

# Chapter 1

## Introduction

### 1-1 Overview

#### Checklist

Congratulations on purchasing your computer motherboard from an acknowledged leader in the industry. Supermicro boards are designed with the utmost attention to detail to provide you with the highest standards in quality and performance.

Please check that the following items have all been included with your motherboard. If anything listed here is damaged or missing, contact your retailer.

- One (1) H8DMT+/H8DMT-INF+ motherboard
- Two (2) SATA cables (CBL-0228L)
- One (1) CD containing drivers and utilities

## 1-2 Contacting Supermicro

### Headquarters

Address: Super Micro Computer, Inc.  
980 Rock Ave.  
San Jose, CA 95131 U.S.A.

Tel: +1 (408) 503-8000

Fax: +1 (408) 503-8008

Email: [marketing@supermicro.com](mailto:marketing@supermicro.com) (General Information)  
[support@supermicro.com](mailto:support@supermicro.com) (Technical Support)

Web Site: [www.supermicro.com](http://www.supermicro.com)

### Europe

Address: Super Micro Computer B.V.  
Het Sterrenbeeld 28, 5215 ML  
's-Hertogenbosch, The Netherlands

Tel: +31 (0) 73-6400390

Fax: +31 (0) 73-6416525

Email: [sales@supermicro.nl](mailto:sales@supermicro.nl) (General Information)  
[support@supermicro.nl](mailto:support@supermicro.nl) (Technical Support)  
[rma@supermicro.nl](mailto:rma@supermicro.nl) (Customer Support)

### Asia-Pacific

Address: Super Micro Computer, Inc.  
4F, No. 232-1, Liancheng Rd.  
Chung-Ho 235, Taipei County  
Taiwan, R.O.C.

Tel: +886-(2) 8226-3990

Fax: +886-(2) 8226-3991

Web Site: [www.supermicro.com.tw](http://www.supermicro.com.tw)

Technical Support:

Email: [support@supermicro.com.tw](mailto:support@supermicro.com.tw)

Tel: 886-2-8228-1366, ext.132 or 139

Figure 1-1. H8DMT-INF+ Image



The H8DMT+ shares the same layout but does not include InfiniBand components.

**Figure 1-2. H8DMT+/H8DMT-INF+ Motherboard Layout**  
(not drawn to scale)

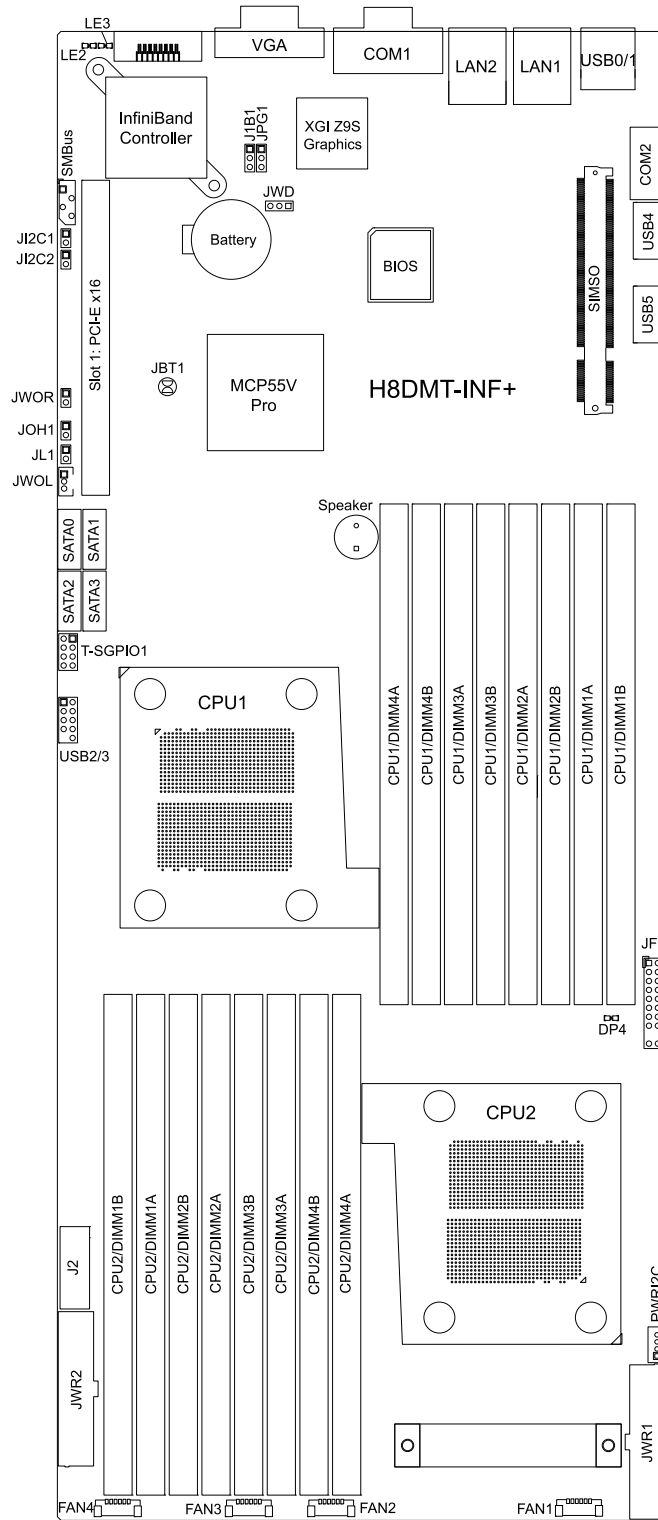

**Notes:**

Jumpers not indicated are for test purposes only.

The H8DMT+ does not include InfiniBand components.

## H8DMT+/H8DMT-INF+ Quick Reference

<b>Jumper</b>	<b>Description</b>	<b>Default Setting</b>
JBT1	CMOS Clear	(See Section 2-7)
JI <sup>2</sup> C1/JI <sup>2</sup> C2	I <sup>2</sup> C to PCI-E Slot	Both Closed (Enabled)
J1B1*	InfiniBand Enable/Disable	Pins 1-2 (Enabled)
JPG1	VGA Enable/Disable	Pins 1-2 (Enabled)
JWD	Watch Dog	Pins 1-2 (Reset)

<b>Connector</b>	<b>Description</b>
COM1/COM2	COM1 Serial Port/Header
FAN 1-4	Chassis/CPU Fan Headers
J2	Auxilliary Power Connector (for IDE drives)
JF1	Front Panel Connector
JL1	Chassis Intrusion Header
JOH1	Overheat Warning Header
JWOL	Wake-On-LAN Header
JWOR	Wake-On-Ring Header
JWR1	20-pin Proprietary Power Connector
JWR2	20-pin Proprietary Power Connector
LAN1/2	Gigabit Ethernet (RJ45) Ports
PWRI <sup>2</sup> C	Power I <sup>2</sup> C Header
SATA0 ~ SATA3	SATA Ports
SIMSO	SIMSO (Remote Management) Slot
SMBus	System Management Bus Header
T-SGPIO-1	Serial General Purpose Input/Output Header
USB0/1, USB2/3/4/5	Universal Serial Bus (USB) Ports, Headers

<b>LED</b>	<b>Description</b>
DP4	Onboard Power LED
LE2*	InfiniBand Physical Link LED (Green)
LE3*	InfiniBand Logical Link LED (Yellow)

\*H8DMT-INF+ only.

## Motherboard Features

### CPU

- Dual AMD Opteron 2000 series (Socket F type) processors

**Note:** Refer to our web site for details on supported processors.

### Memory

- Sixteen single/dual channel DIMM slots supporting up to 64 GB of DDR2-667/533/400 registered ECC SDRAM

**Note:** Due to a CPU limitation, fully populating DIMM slots with DDR2-667 will pull the speed down to 533 MHz (see our web site for possible updates to this). Refer to Section 2-4 before installing memory and our web site for recommended DIMMs.

### Chipset

- nVidia MCP55-V Pro

### Expansion Slots

- One (1) PCI-Express x16 slot
- One (1) SIMSO slot (for IPMI card)

### BIOS

- 8 Mb AMIBIOS® LPC Flash ROM
- APM 1.2, DMI 2.3, PCI 2.2, ACPI 1.0 (ACPI 2.0 is BIOS supported), SMBIOS 2.3, Plug and Play (PnP)

### PC Health Monitoring

- Onboard voltage monitors
- Fan status monitor with firmware/software on/off and speed control
- Watch Dog
- Environmental temperature monitoring via BIOS
- Power-up mode control for recovery from AC power loss
- System resource alert (via included utility program)
- Auto-switching voltage regulator for the CPU core
- CPU thermal trip support
- I<sup>2</sup>C temperature sensing logic

**ACPI Features**

- Microsoft OnNow
- Slow blinking LED for suspend state indicator
- BIOS support for USB keyboard
- Wake-On-LAN (WOL) and Wake-On-Ring (WOR) headers
- Internal/external modem ring-on

**Onboard I/O**

- On-chip SATA controller supporting four (4) SATA ports (RAID 0, 1, 0+1, 5 and JBOD supported)
- One (1) Fast UART 16550 compatible serial port
- On-chip (MCP55-V Pro) Ethernet controller supports two Gigabit LAN ports
- Six (6) USB (Universal Serial Bus 2.0) ports/headers
- Onboard XGI Z9S graphics controller
- H8DMT-INF+: Mellanox InfiniHost MT25204A0-FCC-D for 20Gb/s InfiniBand

**Other**

- Onboard power LED
- Chassis intrusion detection

**CD Utilities**

- BIOS flash upgrade utility

**Dimensions**

- Proprietary form factor: 16.64" x 6.8" (423 x 173 mm)

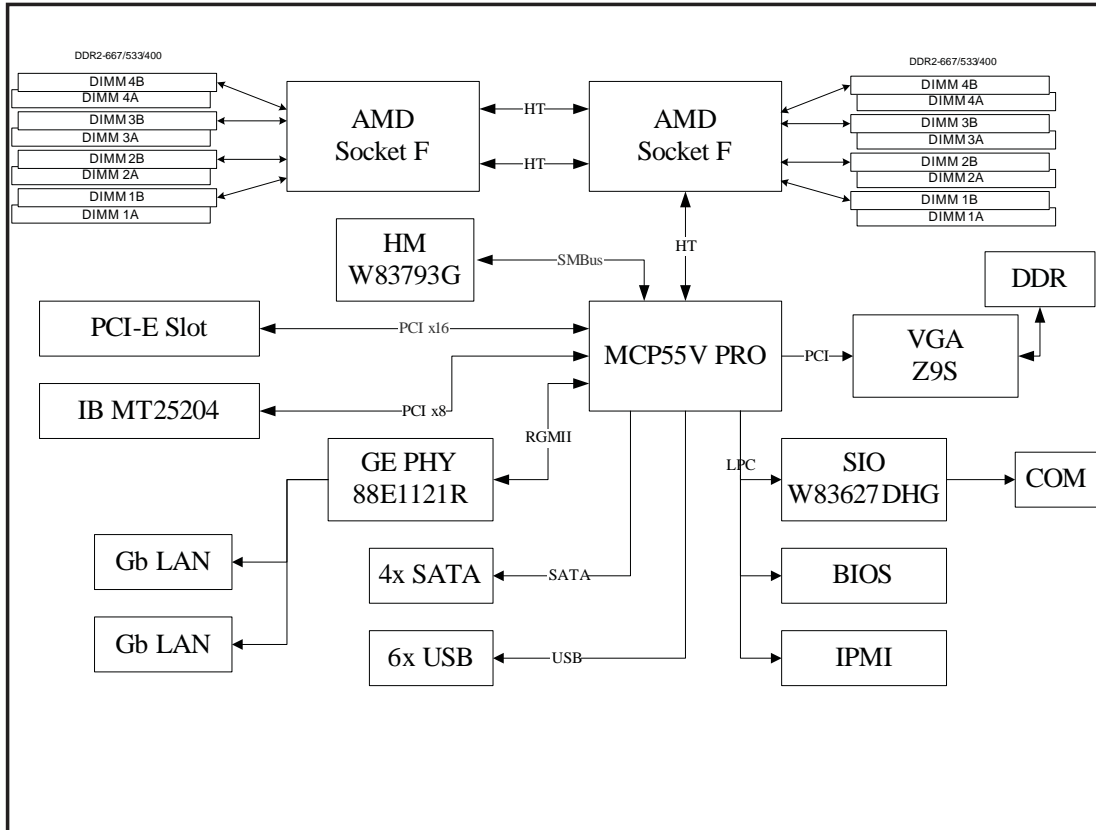

**Figure 1-3. nVidia MCP55-V Pro Chipset:  
System Block Diagram**

**Note:** This is a general block diagram and may not exactly represent the features on your motherboard. See the previous pages for the actual specifications of your motherboard.

## 1-3 Chipset Overview

The H8DMT+/H8DMT-INF+ motherboard is based on the nVidia MCP55-V Pro chipset. The nVidia MCP55 Pro functions as Media and Communications Processor (MCP). Controllers for the system memory are integrated directly into AMD Opteron processors.

### **MCP55-V Pro Media and Communications Processor**

The MCP55-V Pro is a single-chip, high-performance HyperTransport peripheral controller. It includes a 28-lane PCI Express interface, an AMD Opteron 16-bit Hyper Transport interface link, a four-port Serial ATA interface, a dual-port Gb Ethernet interface and a six-port USB 2.0 interface. This hub connects directly to the CPU.

### **HyperTransport Technology**

HyperTransport technology is a high-speed, low latency point to point link that was designed to increase the communication speed by a factor of up to 48x between integrated circuits. This is done partly by reducing the number of buses in the chipset to reduce bottlenecks and by enabling a more efficient use of memory in multi-processor systems. The end result is a significant increase in bandwidth within the chipset.

## 1-4 PC Health Monitoring

This section describes the PC health monitoring features of the H8DMT+/H8DMT-INF+. The motherboard has an onboard System Hardware Monitor chip that supports PC health monitoring.

### **Onboard Voltage Monitors**

The onboard voltage monitor will continuously scan crucial voltage levels. Once a voltage becomes unstable, it will give a warning or send an error message to the screen. Users can adjust the voltage thresholds to define the sensitivity of the voltage monitor. Real time readings of these voltage levels are all displayed in BIOS.

### **Fan Status Monitor with Firmware/Software Speed Control**

The PC health monitor can check the RPM status of the cooling fans. The onboard fans are controlled by thermal management via BIOS.

### **CPU Overheat/Fan Fail LED and Control**

This feature is available when the user enables the CPU overheat/Fan Fail warning function in the BIOS. This allows the user to define an overheat temperature. When this temperature is exceeded or when a fan failure occurs, the Overheat/Fan Fail warning LED is triggered.

### **Auto-Switching Voltage Regulator for the CPU Core**

The 3-phase-switching voltage regulator for the CPU core can support up to 80A and auto-sense voltage IDs ranging from 0.8 V to 1.55V. This will allow the regulator to run cooler and thus make the system more stable.

## 1-5 Power Configuration Settings

This section describes the features of your motherboard that deal with power and power settings.

### **Microsoft OnNow**

The OnNow design initiative is a comprehensive, system-wide approach to system and device power control. OnNow is a term for a PC that is always on but appears to be off and responds immediately to user or other requests.

### **Slow Blinking LED for Suspend-State Indicator**

When the CPU goes into a suspend state, the chassis power LED will start blinking to indicate that the CPU is in suspend mode. When the user presses any key, the CPU will wake-up and the LED will automatically stop blinking and remain on.

### **BIOS Support for USB Keyboard**

If a USB keyboard is the only keyboard in the system, it will function like a normal keyboard during system boot-up.

### **Main Switch Override Mechanism**

The power button can function as a system suspend button. When the user depresses the power button, the system will enter a SoftOff state. The monitor will be suspended and the hard drive will spin down. Depressing the power button again will cause the whole system to wake-up. During the SoftOff state, the power supply provides power to keep the required circuitry in the system alive. In case the system malfunctions and you want to turn off the power, just depress and hold the power button for 4 seconds. The power will turn off and no power will be provided to the motherboard.

### **Wake-On-LAN (WOL)**

Wake-On-LAN is defined as the ability of a management application to remotely power up a computer that is powered off. Remote PC setup, up-dates and access tracking can occur after hours and on weekends so that daily LAN traffic is kept to a minimum and users are not interrupted. The motherboard has a 3-pin header (WOL) to connect to the 3-pin header on a Network Interface Card (NIC) that has WOL capability. Wake-On-LAN must be enabled in BIOS.

### **Wake-On-Ring Header (WOR)**

Wake-up events can be triggered by a device such as the external modem ringing when the system is in the SoftOff state.

## 1-6 Power Supply

As with all computer products, a stable power source is necessary for proper and reliable operation. It is even more important for processors that have high CPU clock rates.

The H8DMT+/H8DMT-INF+ requires the use of proprietary power supplies. Please refer to the pinout information for the power connectors in Section 6 of Chapter 2 for detailed information on power requirements.

In areas where noisy power transmission is present, you may choose to install a line filter to shield the computer from noise. It is recommended that you also install a power surge protector to help avoid problems caused by power surges.

**Warning:** To prevent the possibility of explosion, do not use the wrong type of onboard CMOS battery or install it upside down.

## 1-7 Super I/O

The disk drive adapter functions of the Super I/O chip include a floppy disk drive controller that is compatible with industry standard 82077/765, a data separator, write pre-compensation circuitry, decode logic, data rate selection, a clock generator, drive interface control logic and interrupt and DMA logic. The wide range of functions integrated onto the Super I/O greatly reduces the number of components required for interfacing with floppy disk drives.

The Super I/O provides two high-speed, 16550 compatible serial communication ports (UARTs), one of which supports serial infrared communication. Each UART includes a 16-byte send/receive FIFO, a programmable baud rate generator, complete modem control capability and a processor interrupt system. Both UARTs provide legacy speed with baud rate of up to 115.2 Kbps as well as an advanced speed with baud rates of 250 K, 500 K, or 1 Mb/s, which support higher speed modems.

The Super I/O supports one PC-compatible printer port (SPP), Bi-directional Printer Port (BPP) , Enhanced Parallel Port (EPP) or Extended Capabilities Port (ECP).

The Super I/O provides functions that comply with ACPI (Advanced Configuration and Power Interface), which includes support of legacy and ACPI power management through a SMI or SCI function pin. It also features auto power management to reduce power consumption.

The IRQs, DMAs and I/O space resources of the Super I/O can be flexibly adjusted to meet ISA PnP requirements, which support ACPI and APM (Advanced Power Management).

## Chapter 2

### Installation

#### 2-1 Static-Sensitive Devices

Electrostatic Discharge (ESD) can damage electronic components. To prevent damage to your system board, it is important to handle it very carefully. The following measures are generally sufficient to protect your equipment from ESD.

##### Precautions

- Use a grounded wrist strap designed to prevent static discharge.
- Touch a grounded metal object before removing the board from the antistatic bag.
- Handle the board by its edges only; do not touch its components, peripheral chips, memory modules or gold contacts.
- When handling chips or modules, avoid touching their pins.
- Put the motherboard and peripherals back into their antistatic bags when not in use.
- For grounding purposes, make sure your computer chassis provides excellent conductivity between the power supply, the case, the mounting fasteners and the motherboard.
- Use only the correct type of CMOS onboard battery as specified by the manufacturer. Do not install the CMOS onboard battery upside down, which may result in a possible explosion.

##### Unpacking

The motherboard is shipped in antistatic packaging to avoid static damage. When unpacking the board, make sure the person handling it is static protected.

## 2-2 Processor and Heatsink Installation



*Exercise extreme caution when handling and installing the processor. Always connect the power cord last and always remove it before adding, removing or changing any hardware components.*

### ***Installation Procedure***

Follow the procedures as listed below to install the motherboard into a chassis.

1. Install the processor(s) and the heatsink(s).
2. Install the motherboard in the chassis.
3. Install the memory and add-on cards.
4. Finally, connect the cables and install the drivers.

### ***Installing the Processors***

1. Begin by removing the cover plate that protects the CPU. Lift the lever on the CPU socket until it points straight up. With the lever raised, lift open the silver CPU retention plate.

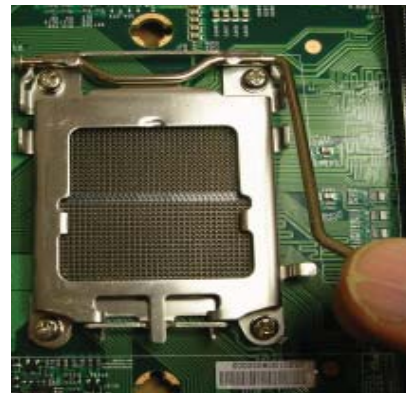

2. Use your thumb and your index finger to hold the CPU. Locate and align pin 1 of the CPU socket with pin 1 of the CPU. Both are marked with a triangle.

Triangles



3. Align pin 1 of the CPU with pin 1 of the socket. Once aligned, carefully place the CPU into the socket. *Do not drop the CPU on the socket, move the CPU horizontally or vertically or rub the CPU against the socket or against any pins of the socket, which may damage the CPU and/or the socket.*



4. With the CPU inserted into the socket, inspect the four corners of the CPU to make sure that it is properly installed and flush with the socket. Then, gently lower the silver CPU retention plate into place.
5. Carefully press the CPU socket lever down until it locks into its retention tab. For a dual-CPU system, repeat these steps to install another CPU into the CPU#2 socket (and into CPU#2, #3 and #4 sockets for a quad-CPU configuration).



**Note:** in single and dual-CPU configurations, memory must be installed in the DIMM slots associated with the installed CPU(s). Memory is limited to a maximum of 32 for single CPU and 64 GB for dual CPU configurations.



### ***Installing the Heatsinks***

We recommend the use of active type heatsinks (except for 1U systems). Use any onboard fan header for the CPU's heatsink fan. To install the heatsink, please follow the installation instructions included with your heatsink package (not included).

## 2-3 Mounting the Motherboard into a Chassis

All motherboards have standard mounting holes to fit different types of chassis. Make sure that the locations of all the mounting holes for both the motherboard and the chassis match. Although a chassis may have both plastic and metal mounting fasteners, metal ones are highly recommended because they ground the motherboard to the chassis. Make sure that the metal standoffs click in or are screwed in tightly.

### ***Check the Compatibility of the Motherboard Ports and the I/O Shield***

1. The H8DMT+/H8DMT-INF+ motherboard requires a chassis that can support a board of 16.64" x 6.8" in size. It was designed to be used in a Supermicro 1U Twin system.
2. Make sure that the I/O ports on the motherboard align with their respective holes in the I/O shield at the rear of the chassis.

### ***Mounting the Motherboard onto the Tray in the Chassis***

1. Carefully mount the motherboard onto the motherboard tray by aligning the motherboard mounting holes with the raised metal standoffs in the tray.
2. Insert screws into all the mounting holes in the motherboard that line up with the standoffs.
3. Then use a screwdriver to secure the motherboard to the mainboard tray - tighten until just snug (if too tight you might strip the threads). Metal screws provide an electrical contact to the motherboard ground to provide a continuous ground for the system.



*Exercise extreme caution when installing or removing memory modules to prevent any possible damage.*

## 2-4 Installing Memory

### ***Installing Memory***

1. Insert each memory module vertically into its slot, paying attention to the notch along the bottom of the module to prevent inserting the module incorrectly (see Figure 2-1).
2. Install to slots CPU1/DIMM1A and CPU1/DIMM1B first, then to CPU1/DIMM2A and CPU1/DIMM2B, etc. Always install in pairs and in the numerical order of the DIMM slots. See support information below.

3. Gently press down on the memory module until it snaps into place.
4. With two CPUs installed, repeat step 2 to populate the CPU2 DIMM slots. Always install pairs of DIMMs to both CPU DIMM slots for more efficient operation.

**Note:** 256 MB, 512 MB, 1 GB, 2 GB and 4 GB memory modules are supported. It is highly recommended that you remove the power cord from the system before installing or changing memory modules. Please refer to our web site for memory that has been tested on the H8DMT+/H8DMT-INF+.

### Support

The H8DMT+/H8DMT-INF+ supports single or dual-channel, DDR2-667/533/400 registered ECC SDRAM. Only interleaved memory is supported, so you must populate two DIMM slots at a time (see procedure above).

Populating two adjacent slots at a time with memory modules of the same size and type will result in interleaved (128-bit) memory, which is faster than non-interleaved (64-bit) memory. **Note:** Due to a CPU limitation, fully populating DIMM slots with DDR2-667 will pull the speed down to 533 MHz. Please see our web site for possible updates to this limitation.

### Maximum Memory

64 GB of DDR2-667/533/400 registered ECC SDRAM.

**Figure 2-1. Side and Top Views of DDR Installation**

#### **To Install:**

Insert module vertically and press down until it snaps into place. The release tabs should close - if they do not you should close them yourself.

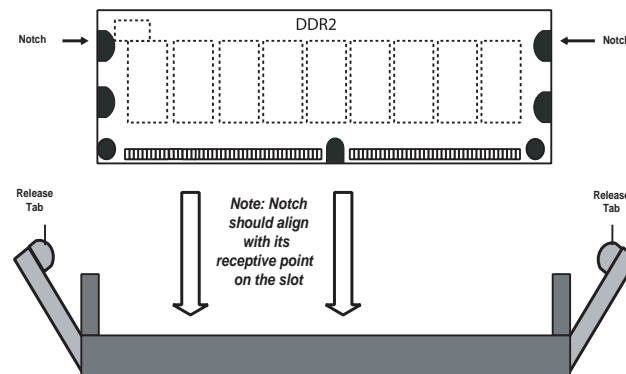

Note the notch in the slot and on the bottom of the DIMM. These prevent the DIMM from being installed incorrectly.

#### **To Remove:**

Use your thumbs to gently push each release tab outward to release the DIMM from the slot.

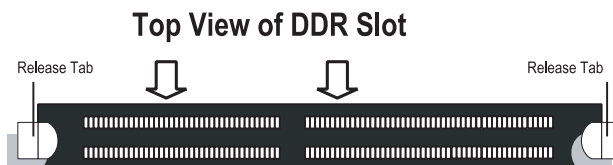

## 2-5 I/O Port and Control Panel Connections

The I/O ports are color coded in conformance with the PC99 specification to make setting up your system easier. See Figure 2-2 below for the colors and locations of the various I/O ports.

**Figure 2-2. I/O Port Locations and Definitions**

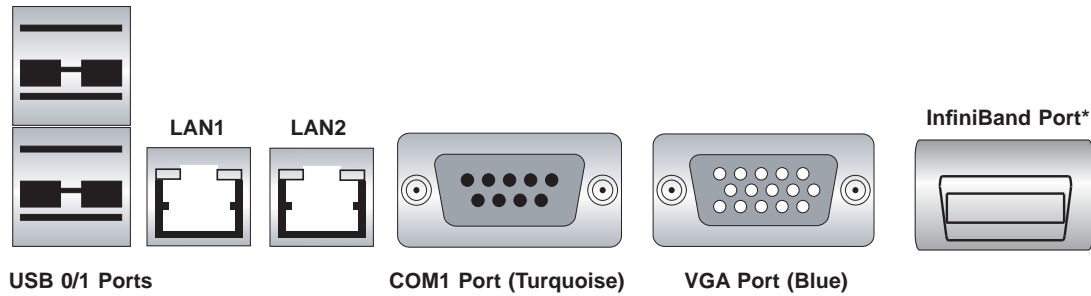

\*The InfiniBand port is included on the H8DMT-INF+ only.

### Front Control Panel

JF1 contains header pins for various front control panel connectors. See Figure 2-3 for the pin definitions of the various connectors. Refer to Section 2-6 for details.

**Figure 2-3. JF1: Front Control Panel Header (JF1)**

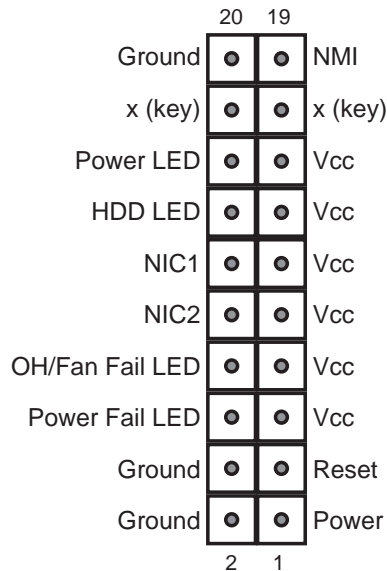

## 2-6 Connector Definitions

### Proprietary Power Connector

The primary power supply connectors (JWR1 and JWR2) are designed for use with Supermicro proprietary power supplies. Refer to the table on the right for the pin definitions of the 20-pin power connectors. This connection supplies power to the chipset, fans and memory.

20-pin Power Connector Pin Definitions (JWR1, JWR2)			
Pin#	Definition	Pin #	Definition
11	PS_ON_N	1	GND_1
12	5V_STBY	2	GND_2
13	GND_6	3	GND_3
14	GND_7	4	GND_4
15	GND_8	5	GND_5
16	NC2	6	NC1
17	12V_5	7	12V_1
18	12V_6	8	12V_2
19	12V_7	9	12V_3
20	12V_8	12	12V_4

### Auxiliary Power Connector

A 4-pin 12V auxiliary power connector is included to provide power to hard drive disks. See the table on the right for pin definitions.

Auxiliary Power Pin Definitions (J2)	
Pin#	Definition
1	+12V
2	Ground
3	Ground
4	+5V

### PW\_ON Connector

The PW\_ON connector is on pins 1 and 2 of JF1. This header should be connected to the chassis power button. See the table on the right for pin definitions.

Power Button Pin Definitions (JF1)	
Pin#	Definition
1	PW_ON
2	Ground

### Reset Connector

The reset connector is located on pins 3 and 4 of JF1 and attaches to the reset switch on the computer chassis. See the table on the right for pin definitions.

Reset Button Pin Definitions (JF1)	
Pin#	Definition
3	Reset
4	Ground

**Overheat/Fan Fail LED (OH)**

Connect an LED to the OH connection on pins 7 and 8 of JF1 to provide advanced warning of chassis overheating or fan failure. Refer to the table on the right for pin definitions and status indicators.

OH/Fan Fail LED Pin Definitions (JF1)		OH/Fan Fail LED Status	
Pin#	Definition	State	Indication
7	Vcc	Solid	Overheat
8	Control	Blinking	Fan fail

**NIC2 (LAN2) LED**

The LED connections for LAN2 are on pins 9 and 10 of JF1. Attach LAN LED cables to display network activity. See the table on the right for pin definitions.

NIC2 LED Pin Definitions (JF1)	
Pin#	Definition
9	Vcc
10	Ground

**NIC1 (LAN1) LED**

The LED connections for LAN1 are on pins 11 and 12 of JF1. Attach LAN LED cables to display network activity. See the table on the right for pin definitions.

NIC1 LED Pin Definitions (JF1)	
Pin#	Definition
11	Vcc
12	Ground

**HDD LED**

The HDD LED connection is located on pins 13 and 14 of JF1. Attach the hard drive LED cable here to display disk activity (for any hard drives on the system, including SAS, Serial ATA and IDE). See the table on the right for pin definitions.

HDD LED Pin Definitions (JF1)	
Pin#	Definition
13	Vcc
14	HD Active

**Power On LED**

The Power On LED connector is located on pins 15 and 16 of JF1. This connection is used to provide LED indication of power being supplied to the system. See the table on the right for pin definitions.

Power LED Pin Definitions (JF1)	
Pin#	Definition
15	5V Stby
16	Control

### NMI Button

The non-maskable interrupt button header is located on pins 19 and 20 of JF1. Refer to the table on the right for pin definitions.

NMI Button Pin Definitions (JF1)	
Pin#	Definition
19	Control
20	Ground

### Universal Serial Bus Ports

Two Universal Serial Bus ports (USB 2.0) are located beside the LAN1/2 ports. Two additional ports (USB4/5) are included on the motherboard near the SIMSO slot. See the table on the right for pin definitions.

Universal Serial Bus Ports Pin Definitions (USB0/1, USB4/5)			
USB0		USB1	
Pin #	Definition	Pin #	Definition
1	+5V	1	+5V
2	PO-	2	PO-
3	PO+	3	PO+
4	Ground	4	Ground

### USB Headers

Two USB 2.0 headers (USB2/3) are also included on the motherboard. These may be connected to provide front side access. A USB cable (not included) is needed for the connection. See the table on the right for pin definitions.

Universal Serial Bus Headers Pin Definitions (USB2/3)			
USB2		USB3/4	
Pin #	Definition	Pin #	Definition
1	+5V	1	+5V
2	PO-	2	PO-
3	PO+	3	PO+
4	Ground	4	Ground
5	Key	5	No connection

### Power I<sup>2</sup>C

The JPI<sup>2</sup>C header is for power I<sup>2</sup>C, which may be used to monitor the status of the power supply, fan and system temperature. See the table on the right for pin definitions.

Power I <sup>2</sup> C Pin Definitions (JPI <sup>2</sup> C)	
Pin#	Definition
1	Data
2	Ground
3	Clock
4	NC

### Serial Ports

The COM1 serial port is located beside the VGA port. Refer to the motherboard layout for the location of the COM2 header. See the table on the right for pin definitions.

Serial Port Pin Definitions (COM1/COM2)			
Pin #	Definition	Pin #	Definition
1	DCD	6	DSR
2	RXD	7	RTS
3	TXD	8	CTS
4	DTR	9	RI
5	Ground	10	NC

**Note:** NC indicates no connection.

### Fan Headers

The H8DMT+/H8DMT-INF+ has four 6-pin proprietary fan headers. Each fan header supports two 3-pin fans. See the table on the right for pin definitions.

**Note:** The onboard fan speed is controlled by the CPU die temperature.

Fan Header Pin Definitions (Fan1 - Fan4)			
Pin #	Definition	Pin #	Definition
1	PWR (DC Speed CTRL)	4	Ground
2	Tachometer for Fan 1/3/5	5	Tachometer for Fan 2/4/6
3	Ground	6	PWR (DC Speed CTRL)

### LAN1/2 (Ethernet Ports)

Two Gigabit Ethernet ports (designated LAN1 and LAN2) are located beside the COM2 port. These Ethernet ports accept RJ45 type cables.



### Overheat LED

Connect an LED to the JOH1 header to provide warning of chassis overheating. See the table on the right for pin definitions.

Overheat LED Pin Definitions (JOH1)	
Pin#	Definition
1	3.3V
2	OH Active

### Chassis Intrusion

A Chassis Intrusion header is located at JL1. Attach the appropriate cable to inform you of a chassis intrusion.

Chassis Intrusion Pin Definitions (JL1)	
Pin#	Definition
1	Battery voltage
2	Intrusion signal

### Wake-On-LAN

The Wake-On-LAN header is designated JWOL. See the table on the right for pin definitions. You must have a LAN card with a Wake-On-LAN connector and cable to use the Wake-On-LAN feature.

Wake-On-LAN Pin Definitions (JWOL)	
Pin#	Definition
1	+5V Standby
2	Ground
3	Wake-up

### Wake-On-Ring

The Wake-On-Ring header is designated JWOR. This function allows your computer to receive and "wake-up" by an incoming call to the modem when in suspend state. See the table on the right for pin definitions. You must have a Wake-On-Ring card and cable to use this feature.

Wake-On-Ring Pin Definitions (JWOR)	
Pin#	Definition
1	Ground (Black)
2	Wake-up

### SMBus Header

The header at SMBus is for the System Management Bus. Connect the appropriate cable here to utilize SMB on the system. See the table on the right for pin definitions.

SMBus Header Pin Definitions (SMBus)	
Pin#	Definition
1	Data
2	Ground
3	Clock
4	No Connection

### SGPIO

The T-SGPIO1 (Serial General Purpose Input/Output) header provides a bus between the SATA controller and the SATA drive backplane to provide SATA enclosure management functions. Connect the appropriate cables from the backplane to the T-SGPIO1 header to utilize SATA management functions on your system.

SGPIO Header Pin Definitions (T-SGPIO1)			
Pin#	Definition	Pin #	Definition
1	NC	2	NC
3	Ground	4	Data
5	Load	6	Ground
7	NC	8	NC

**Note:** NC indicates no connection.

## 2-7 Jumper Settings

### Explanation of Jumpers

To modify the operation of the motherboard, jumpers can be used to choose between optional settings. Jumpers create shorts between two pins to change the function of the connector. Pin 1 is identified with a square solder pad on the printed circuit board. See the diagram at right for an example of jumping pins 1 and 2. Refer to the motherboard layout page for jumper locations.

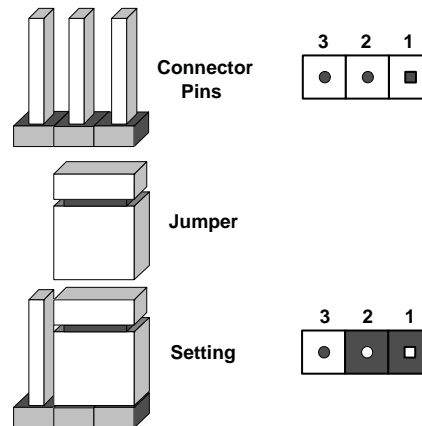

Note: On two-pin jumpers, "Closed" means the jumper is on and "Open" means the jumper is off the pins.

### CMOS Clear

JBT1 is used to clear CMOS, which will also clear any passwords. Instead of pins, this jumper consists of contact pads to prevent accidentally clearing the contents of CMOS.

#### To Clear CMOS

1. First power down the system and unplug the power cord(s).
2. With the power disconnected, short the CMOS pads with a metal object such as a small screwdriver.
3. Remove the screwdriver (or shorting device).
4. Reconnect the power cord(s) and power on the system.

**Note:** Do not use the PW ON connector to clear CMOS.



JBT1 contact pads

### VGA Enable/Disable

JPG1 allows you to enable or disable the VGA port. The default position is on pins 1 and 2 to enable VGA. See the table on the right for jumper settings.

VGA Enable/Disable Jumper Settings (JPG1)	
Jumper Setting	Definition
Pins 1-2	Enabled
Pins 2-3	Disabled

### I<sup>2</sup>C to PCI-Express Slot

JIP<sup>2</sup>C1/JIP<sup>2</sup>C2 allows you to enable the I<sup>2</sup>C bus to communicate with the PCI-Express slot. For the jumpers to work properly, please set both jumpers to the same setting. If enabled, both jumpers must be enabled. If disabled, both jumpers must be disabled. See the table on the right for jumper settings.

I <sup>2</sup> C to PCI-Express Slot Jumper Settings (JIP <sup>2</sup> C1/JIP <sup>2</sup> C2)	
Jumper Setting	Definition
Closed	Enabled
Open	Disabled

### Watch Dog Enable/Disable

JWD enables the Watch Dog function, a system monitor that takes action when a software application freezes the system. Jumping pins 1-2 will have WD reboot the system if a program freezes. Jumping pins 2-3 will generate a non-maskable interrupt for the program that has frozen. See the table on the right for jumper settings. Watch Dog must also be enabled in BIOS.

Watch Dog Jumper Settings (JWD)	
Jumper Setting	Definition
Pins 1-2	Reset
Pins 2-3	NMI
Open	Disabled

**Note:** when Watch Dog is enabled, the user must write their own application software to disable the Watch Dog Timer.

### InfiniBand Port Enable/Disable

J1B1 enables or disables the InfiniBand port on the H8DMT-INF+. The default position is on pins 1 and 2 to enable the port. See the table on the right for jumper settings.

InfiniBand Port Enable/Disable Jumper Settings (J1B1)	
Jumper Setting	Definition
Pins 1-2	Enabled
Pins 2-3	Disabled

## 2-8 Onboard Indicators

### LAN1/LAN2 LEDs

The Ethernet ports (located beside the VGA port) have two LEDs. On each Gb LAN port, one LED blinks to indicate activity while the other may be green, amber or off to indicate the speed of the connection. See the table on the right for the functions associated with the connection speed LED.

LAN LED (Connection Speed Indicator)	
LED Color	Definition
Off	10 MHz
Green	100 MHz
Amber	1 GHz

### Power LED

DP4 is an Onboard Power LED. When this LED is lit, it means power is present on the serverboard. Be sure to turn off the system and unplug the power cord(s) before removing or installing components.

Power LED (DP4)	
State	System Status
On	Standby power present on motherboard
Off	No power connected

### InfiniBand LED Indicators

Two InfiniBand LED indicators (LE2/LE3) are located near the InfiniBand port. The green LED (LE2) is the InfiniBand link LED while the yellow LED (LE3) indicates activity. Refer to the tables on the right for details.

InfiniBand Link LED (LE2)		
Color	Status	Definition
Green	Solid	InfiniBand Connected
Off	Off	No connection

InfiniBand Link LED (LE3)		
Color	Status	Definition
Yellow	Solid	InfiniBand: Active
Yellow	Dim	InfiniBand: Connected, Activity: Idle
Off	Off	No connection

---

## 2-9 Drive Connections

There are no IDE or floppy drive connectors on the motherboard. Use the following information to connect the SATA drive cables.

### SATA Ports

There are no jumpers to configure the SATA ports, which are designated SATA0 through SATA3. See the table on the right for pin definitions.

SATA Ports Pin Definitions (SATA0-SATA3)	
Pin #	Definition
1	Ground
2	TXP
3	TXN
4	Ground
5	RXN
6	RXP
7	Ground

## 2-10 Enabling SATA RAID

Now that the hardware is set up, you must install the operating system and the SATA RAID drivers, if you wish to use RAID with your SATA drives. The installation procedure differs depending on whether you wish to have the operating system installed on a RAID array or on a separate non-RAID drive. See the instructions below for details.

### **Serial ATA (SATA)**

Serial ATA (SATA) is a physical storage interface that employs a single cable with a minimum of four wires to create a point-to-point connection between devices. This connection is a serial link that supports a SATA transfer rate from 150 MBps. The serial cables used in SATA are thinner than the traditional cables used in Parallel ATA (PATA) and can extend up to one meter in length, compared to only 40 cm for PATA cables. Overall, SATA provides better functionality than PATA.

### **Installing the OS/SATA Driver**

Before installing the OS (operating system) and SATA RAID driver, you must decide if you wish to have the operating system installed as part of a bootable RAID array or installed to a separate non-RAID hard drive. If on a separate drive, you may install the driver either during or after the OS installation. If you wish to have the OS on a SATA RAID array, you must follow the procedure below and install the driver during the OS installation.

### ***Building a Driver Diskette***

You must first build a driver diskette from the Supermicro CD-ROM that was included with the system. (You will have to create this disk on a computer that is already running and with the OS installed.) Insert the CD into your CD-ROM drive and start the system. A display as shown in Figure 2-4 will appear. Click on the icon labeled "Build Driver Diskettes and Manuals" and follow the instructions to create a floppy disk with the driver on it. Once it's been created, remove the floppy and insert the installation CD for the Windows Operating System you wish to install into the CD-ROM drive of the new system you are about to configure.

### ***Enabling SATA RAID in the BIOS***

Before installing the Windows Operating System, you must change some settings in BIOS. Boot up the system and hit the <Del> key to enter the BIOS Setup Utility. After the Setup Utility loads,

1. Use the arrow keys to move to the Exit menu. Scroll down with the arrow keys to the "Load Optimal Defaults setting and press <Enter>. Select "OK" to confirm, then <Enter> to load the default settings.
2. Use the arrow keys to move to the "Advanced" menu, then scroll down to "nVidia RAID Setup" and press the <Enter> key. Once in the submenu, scroll down to "nVidia RAID Function" and enable the setting, which will cause the SATA0/1/2 Primary/Secondary settings to appear. Enable the SATA devices and channels you will be using.
3. Hit the <Esc> key twice and scroll to the Exit menu. Select "Save Changes and Exit" and hit <enter>, then hit <Enter> again to verify.
4. After exiting the BIOS Setup Utility, the system will reboot. When prompted during the startup, press the <F10> key when prompted to run the nVidia RAID Utility program.

### **Using the nVidia RAID Utility**

The nVidia RAID Utility program is where you can define the drives you want to include in the RAID array and the mode and type of RAID. Two main windows are shown in the utility. The "Free Disks" window on the left will list all available drives. Use the arrow keys to select and move drives to the window on the right, which lists all drives that are to become part of the RAID array.

Once you have finished selecting the drives and type of RAID you wish to use for your RAID array, press the <F7> key. You will be prompted to verify your choice; if you want to continue with your choices, select "Yes". Note that selecting "Yes" will clear all previous data from the drives you selected to be a part of the array. You are then given the choice of making the RAID array bootable by pressing the the <B> key. After you have finished, press the <Ctrl> and <X> keys simultaneously.

### **Installing the OS and Drivers**

With the Windows OS installation CD in the CD-ROM drive, restart the system. When you see the prompt, hit the <F6> key to enter Windows setup. Eventually a blue screen will appear with a message that begins "Windows could not determine the type of one or more storage devices . . ." When you see the screen, hit the <S> key to "Specify Additional Device", then insert the driver diskette you just created

---

into the floppy drive. Highlight "Manufacturer Supplied Hardware Support Disk" and hit the <Enter> key. Highlight the first "nVidia RAID" driver shown and press the <Enter> key to install it. Soon a similar blue screen will appear again. Again hit the <S> key, then highlight the second item, "nForce Storage Controller" and press the <Enter> key, then <Enter> again to continue with the Windows setup.

## 2-11 Installing Drivers

The CD that came bundled with the system contains drivers, some of which must be installed, such as the chipset driver. After inserting this CD into your CD-ROM drive, the display shown in Figure 2-4 should appear. (If this display does not appear, click on the My Computer icon and then on the icon representing your CD-ROM drive. Finally, double click on the S "Setup" icon.)

Click the icons showing a hand writing on paper to view the readme files for each item. Click the computer icons to the right of these items to install each item (from top to the bottom) one at a time. After installing each item, you should reboot the system before moving on to the next item on the list. The bottom icon with a CD on it allows you to view the entire contents of the CD.

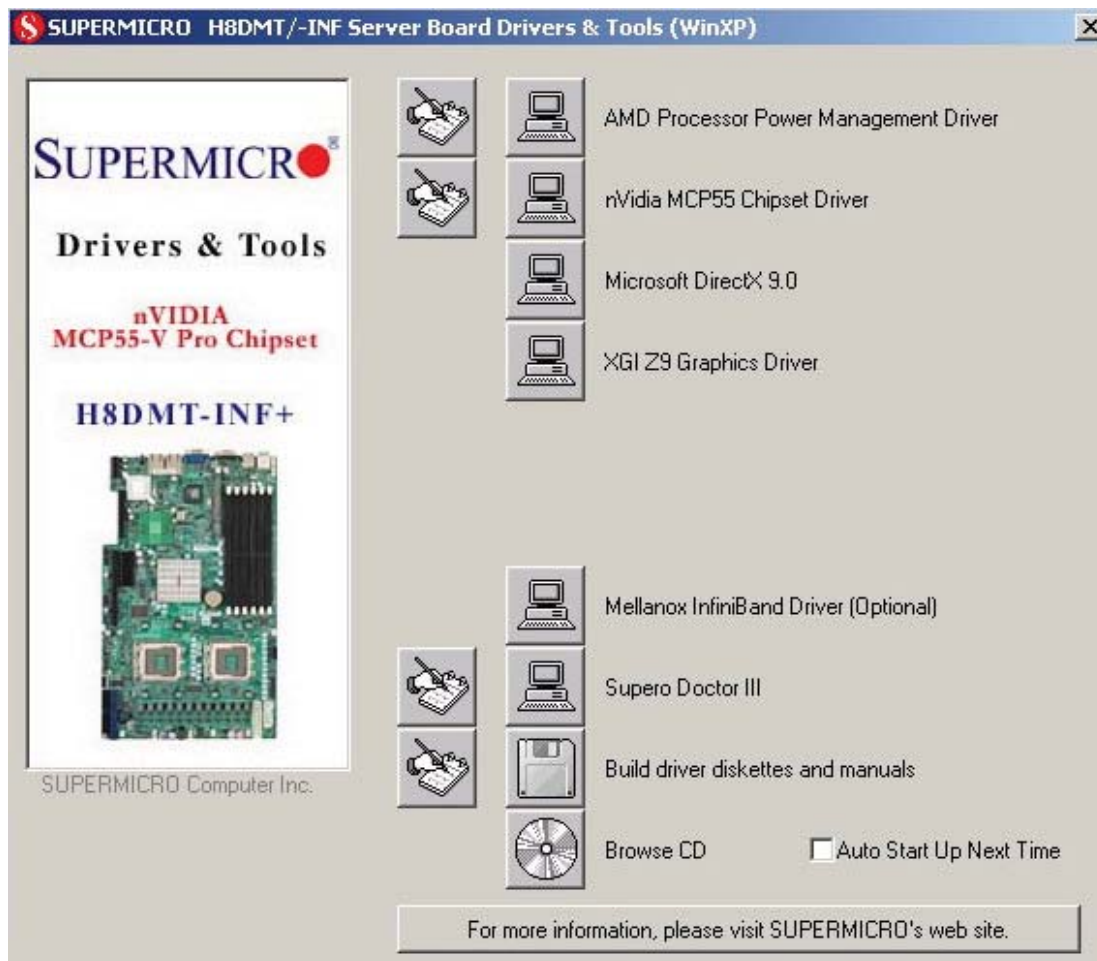

Figure 2-4. Driver/Tool Installation Display Screen

# Notes

## Chapter 3

# Troubleshooting

### 3-1 Troubleshooting Procedures

Use the following procedures to troubleshoot your system. If you have followed all of the procedures below and still need assistance, refer to the 'Technical Support Procedures' and/or 'Returning Merchandise for Service' section(s) in this chapter. Always disconnect the AC power cord before adding, changing or installing any hardware components.

#### Before Power On

1. Check that the onboard power LED is lit (DP4 on the motherboard).
2. Make sure that the power connector is connected to your power supply.
3. Make sure that no short circuits exist between the motherboard and chassis.
4. Disconnect all cables from the motherboard, including those for the keyboard and mouse.
5. Remove all add-on cards.
6. Install a CPU and heatsink (making sure it is fully seated) and connect the internal (chassis) speaker and the power LED to the motherboard. Check all jumper settings as well.
7. Use the correct type of onboard CMOS battery as recommended by the manufacturer. To avoid possible explosion, do not install the CMOS battery upside down.

#### No Power

1. Make sure that no short circuits exist between the motherboard and the chassis.
2. Verify that all jumpers are set to their default positions.
3. Check that the 115V/230V switch on the power supply is properly set.

4. Turn the power switch on and off to test the system.
5. The battery on your motherboard may be old. Check to verify that it still supplies ~3VDC. If it does not, replace it with a new one.

### **No Video**

1. If the power is on but you have no video, remove all the add-on cards and cables.
2. Use the speaker to determine if any beep codes exist. Refer to Appendix A for details on beep codes.

---

#### **NOTE**

If you are a system integrator, VAR or OEM, a POST diagnostics card is recommended. For I/O port 80h codes, refer to App. B.

---

### **Memory Errors**

1. Make sure that the DIMM modules are properly and fully installed.
2. You should be using registered ECC DDR-2 memory (see next page). Also, it is recommended that you use the same memory type and speed for all DIMMs in the system. See Section 2-4 for memory details.
3. Check for bad DIMM modules or slots by swapping modules between slots and noting the results.
4. Check the power supply voltage 115V/230V switch.

### **Losing the System's Setup Configuration**

1. Make sure that you are using a high quality power supply. A poor quality power supply may cause the system to lose the CMOS setup information. Refer to Section 1-6 for details on recommended power supplies.
2. The battery on your motherboard may be old. Check to verify that it still supplies ~3VDC. If it does not, replace it with a new one.
3. If the above steps do not fix the setup configuration problem, contact your vendor for repairs.

## 3-2 Technical Support Procedures

Before contacting Technical Support, please take the following steps. Also, note that as a motherboard manufacturer, we do not sell directly to end-users, so it is best to first check with your distributor or reseller for troubleshooting services. They should know of any possible problem(s) with the specific system configuration that was sold to you.

1. Please review the 'Troubleshooting Procedures' and 'Frequently Asked Questions' (FAQs) sections in this chapter or see the FAQs on our web site before contacting Technical Support.
2. BIOS upgrades can be downloaded from our web site. **Note:** Not all BIOS can be flashed depending on the modifications to the boot block code.
3. If you still cannot resolve the problem, include the following information when contacting us for technical support:
  - Motherboard model and PCB revision number
  - BIOS release date/version (this can be seen on the initial display when your system first boots up)
  - System configuration

An example of a Technical Support form is posted on our web site.

Distributors: For immediate assistance, please have your account number ready when contacting our technical support department by e-mail.

## 3-3 Frequently Asked Questions

**Question: What type of memory does my motherboard support?**

**Answer:** The H8DMT+/H8DMT-INF+ supports up to 64 GB of DDR2-667/533/400 registered ECC SDRAM (or 32 GB with a single CPU installed). Both single and dual channel configurations are supported. See Section 2-4 for details on installing memory.

**Question: How do I update my BIOS?**

**Answer:** It is recommended that you **not** upgrade your BIOS if you are not experiencing problems with your system. Updated BIOS files are located on our web site. Please check our BIOS warning message and the information on how to update your BIOS on our web site. Also, check the current BIOS revision and make sure it is newer than your current BIOS before downloading.

Select your motherboard model on the web page and download the corresponding BIOS file to your computer. Unzip the BIOS update file, in which you will find the

readme.txt (flash instructions), the afudos.exe (BIOS flash utility) and the BIOS image (xxx.rom) files. Copy these files to a bootable floppy disk, insert the disk into drive A and reboot the system. At the DOS prompt after rebooting, enter the command "flash" (without quotation marks) then type in the BIOS file that you want to update with (xxxx.rom).

**Question: What's on the CD that came with my motherboard?**

**Answer:** The supplied compact disc has quite a few drivers and programs that will greatly enhance your system. We recommend that you review the CD and install the applications you need. Applications on the CD include chipset drivers for Windows and security and audio drivers.

**Question: Why can't I turn off the power using the momentary power on/off switch?**

**Answer:** The instant power off function is controlled in BIOS by the Power Button Mode setting. When the On/Off feature is enabled, the motherboard will have instant off capabilities as long as the BIOS has control of the system. When the Standby or Suspend feature is enabled or when the BIOS is not in control such as during memory count (the first screen that appears when the system is turned on), the momentary on/off switch must be held for more than four seconds to shut down the system. This feature is required to implement the ACPI features on the motherboard.

### **3-4 Returning Merchandise for Service**

A receipt or copy of your invoice marked with the date of purchase is required before any warranty service will be rendered. You can obtain service by calling your vendor for a Returned Merchandise Authorization (RMA) number. When returning to the manufacturer, the RMA number should be prominently displayed on the outside of the shipping carton, and mailed prepaid or hand-carried. Shipping and handling charges will be applied for all orders that must be mailed when service is complete.

For faster service, RMA authorizations may be requested online (<http://www.supermicro.com/support/rma/>).

This warranty only covers normal consumer use and does not cover damages incurred in shipping or from failure due to the alteration, misuse, abuse or improper maintenance of products.

During the warranty period, contact your distributor first for any product problems.

## Chapter 4

# BIOS

### 4-1 Introduction

This chapter describes the AMIBIOS™ Setup utility for the H8DMT+/H8DMT-INF+. The AMI ROM BIOS is stored in a flash chip and can be easily upgraded using a floppy disk-based program.

**Note:** Due to periodic changes to the BIOS, some settings may have been added or deleted and might not yet be recorded in this manual. Please refer to the Manual Download area of our web site for any changes to BIOS that may not be reflected in this manual.

#### Starting the Setup Utility

To enter the BIOS Setup Utility, hit the <Delete> key while the system is booting-up. (In most cases, the <Delete> key is used to invoke the BIOS setup screen. There are a few cases when other keys are used, such as <F1>, <F2>, etc.) Each main BIOS menu option is described in this manual.

The Main BIOS screen has two main frames. The left frame displays all the options that can be configured. "Grayed-out" options cannot be configured. The right frame displays the key legend. Above the key legend is an area reserved for a text message. When an option is selected in the left frame, it is highlighted in white. Often a text message will accompany it. (Note that BIOS has default text messages built in. We retain the option to include, omit, or change any of these text messages.) Settings printed in **Bold** are the default values.

A " ►" indicates a submenu. Highlighting such an item and pressing the <Enter> key will open the list of settings within that submenu.

The BIOS setup utility uses a key-based navigation system called hot keys. Most of these hot keys (<F1>, <F10>, <Enter>, <ESC>, <Arrow> keys, etc.) can be used at any time during the setup navigation process.

## 4-2 Main Menu

When you first enter AMI BIOS Setup Utility, you will see the Main Menu screen. You can always return to the Main Menu by selecting the **Main** tab on the top of the screen with the arrow keys.

The Main Menu screen provides you with a system overview, which includes the version, built date and ID of the AMIBIOS, the type, speed and number of the processors in the system and the amount of memory installed in the system.

### System Time/System Date

You can edit this field to change the system time and date. Highlight *System Time* or *System Date* using the <Arrow> keys. Enter new values through the keyboard. Press the <Tab> key or the <Arrow> keys to move between fields. The date must be entered in DAY/MM/DD/YYYY format. The time is entered in HH:MM:SS format. Please note that time is in a 24-hour format. For example, 5:30 A.M. appears as 05:30:00 and 5:30 P.M. as 17:30:00.

## 4-3 Advanced Settings Menu

### ► BIOS Features

#### Quick Boot

If Enabled, this option will skip certain tests during POST to reduce the time needed for the system to boot up. The options are **Enabled** and Disabled.

#### Quiet Boot

If Disabled, normal POST messages will be displayed on boot-up. If **Enabled**, this display the OEM logo instead of POST messages.

#### OS Installation

Change this setting if using a 64-bit Linux operating system. The available options are **Other** and Linux.

#### Interrupt 19 Capture

Select Enabled to allow ROMs to trap Interrupt 19. The options are Enabled and **Disabled**.

#### Wait for F1 if Error

This setting controls the system response when an error is detected during the boot sequence. When enabled, BIOS will stop the boot sequence when an error is

detected, at which point you will need to press the F1 button to re-enter the BIOS setup menu. The options are **Enabled** and Disabled.

### **ACPI Mode**

Use this setting to determine whether ACPI mode will be used. The options are **Yes** and No.

## ▶ **Advanced ACPI Configuration**

### **ACPI Version Features**

Use this setting to determine which ACPI version to use. Options are **ACPI v1.0**, ACPI v2.0 and ACPI v3.0.

### **ACPI APIC Support**

Determines whether to include the ACPI APIC table pointer in the RSDT pointer list. The available options are **Enabled** and Disabled.

### **ACPI OEMB Table**

Determines whether to include the ACPI APIC table pointer in the RSDT pointer list. The available options are **Enabled** and Disabled.

### **Headless Mode**

Use this setting to Enable or **Disable** headless operation mode through ACPI.

## ▶ **General WHEA Configuration**

### **WHEA Support**

Use this setting to **Enable** or Disable WHEA (Windows Hardware Error Architecture) support. WHEA provides a common infrastructure for reporting hardware errors on Windows platforms and was designed to improve recovery following fatal hardware errors.

### **Power Button Mode**

Allows the user to change the function of the power button. Options are **On/Off** and Suspend.

### **Watch Dog Timer Select**

This setting is used to Enable or **Disable** the Watch Dog Timer function. It must be used in conjunction with the Watch Dog jumper (see Chapter 2 for details). To enable, choose from 1, 2, 3, 4, 8, 15 or 30 min.

### **Restore on AC Power Loss**

This setting allows you to choose how the system will react when power returns after an unexpected loss of power. The options are Power Off, Power On and **Last State**.

### **MPS Revision**

This setting allows the user to select the MPS revision level. The options are 1.1 and **1.4**.

## **▶ SATA Configuration**

### **Serial ATA Devices**

This setting is used to determine if SATA drives will be used and how many. Options are Disabled, Device 0 and **Device 0/1**.

### **nVidia RAID Function**

This setting is used to Enable or **Disable** the nVidia ROM. If Enabled, the setting below will appear.

### **SATA0/1 Primary/Secondary Channel**

This setting is used to Enable or **Disable** the SATA0 Primary, SATA0 Secondary, SATA1 Primary and SATA1 Secondary, channels (four settings total). If enabled, the following settings will appear:

## **▶ SerialATA 0/1 Primary/Secondary Channel**

### **LBA/Large Mode**

LBA (Logical Block Addressing) is a method of addressing data on a disk drive. The options are Disabled and **Auto**.

### **Block (Multi-Sector Transfer)**

Block mode boosts IDE drive performance by increasing the amount of data transferred. Only 512 bytes of data can be transferred per interrupt if block mode is not used. Block mode allows transfers of up to 64 KB per interrupt. Select "Disabled" to allow the data to be transferred from and to the device one sector at a time. Select "Auto" to allow the data transfer from and to the device occur multiple sectors at a time if the device supports it. The options are **Auto** and Disabled.

### **PIO Mode**

PIO (Programmable I/O) mode programs timing cycles between the IDE drive and the programmable IDE controller. As the PIO mode increases, the cycle time decreases. The options are **Auto**, 0, 1, 2, 3, and 4. Select Auto to allow BIOS to auto detect the PIO mode. Use this value if the IDE disk drive support cannot be determined. Select 0 to allow BIOS to use PIO mode 0, which has a data transfer rate of 3.3 MBs. Select 1 to allow BIOS to use PIO mode 1, which has a data transfer rate of 5.2 MBs. Select 2 to allow BIOS to use PIO mode 2, which has a data transfer rate of 8.3 MBs. Select 3 to allow BIOS to use PIO mode 3, which has a data transfer rate of 11.1 MBs. Select 4 to allow BIOS to use PIO mode 4, which has a data transfer rate of 16.6 MBs. This setting generally works with all hard disk drives manufactured after 1999. For other disk drives, such as IDE CD-ROM drives, check the specifications of the drive.

### **DMA Mode**

Selects the DMA Mode. Options are **Auto**, SWDMA0, SWDMA1, SWDMA2, MWDMA0, MDWDMA1, MWDMA2, UDMA0, UDMA1, UDMA2, UDMA3, UDMA4 and UDMA5. (SWDMA=Single Word DMA, MWDMA=Multi Word DMA, UDMA=UltraDMA.)

### **S.M.A.R.T.**

Self-Monitoring Analysis and Reporting Technology (SMART) can help predict impending drive failures. Select "Auto" to allow BIOS to auto detect hard disk drive support. Select "Disabled" to prevent AMI BIOS from using the S.M.A.R.T. Select "Enabled" to allow AMI BIOS to use the S.M.A.R.T. to support hard drive disk. The options are Disabled, Enabled, and **Auto**.

### **32-Bit Data Transfer**

Select "Enabled" to activate the function of 32-Bit data transfer. Select "Disabled" to deactivate the function. The options are **Enabled** and Disabled.

## **► PCI/PnP Configuration**

### **Slot 1 OPROM**

Use this setting to Enable or **Disable** the OPROM (Option ROM firmware) for slot 1. The options are **Yes** and No.

### **Load Onboard LAN Option ROM**

Use this setting to Enable or **Disable** the onboard option ROM. This setting must be enabled to view the Boot Menu settings.

### Clear NVRAM

Select Yes to clear NVRAM during boot-up. The options are Yes and **No**.

### Plug & Play OS

Select Yes to allow the OS to configure Plug & Play devices. (This is not required for system boot if your system has an OS that supports Plug & Play.) Select **No** to allow AMIBIOS to configure all devices in the system.

### PCI Latency Timer

This option sets the latency of all PCI devices on the PCI bus. Select a value to set the PCI latency in PCI clock cycles. Options are 32, **64**, 96, 128, 160, 192, 224 and 248.

## ► Advanced Chipset Control

### ► NorthBridge Configuration

#### ► Memory Configuration

#### Bank Interleaving

Select Auto to automatically enable a bank-interleaving memory scheme when this function is supported by the processor. The options are **Auto** and Disabled.

#### Channel Interleaving

Selects the channel-interleaving memory scheme when this function is supported by the processor. The options are Disabled, Address Bits 6, Address Bits 12, **XOR of Address Bits [20:16, 6]** and XOR of Address Bits [20:16, 9].

#### Enable Clock to All Dimms

Use this setting to enable unused clocks to all DIMMSs, even if some DIMM slots are unpopulated. Options are Enabled and **Disabled**.

#### Mem Clk Tristate C3/ALTVID

Use this setting to Enable or **Disable** memory clock tristate during C3 and ALT VID.

#### Memory Hole Remapping

When "Enabled", this feature enables hardware memory remapping around the memory hole. Options are **Enabled** and Disabled.

**CS Sparing**

This setting will reserve a spare memory rank in each node when enabled. Options are Enable and **Disable**.

**DCT Unganged Mode**

This setting enables unganged DRAM mode (64-bit). Options are Auto (ganged mode) and **Always** (unganged mode).

**Power Down Enable**

This setting enables or disables DDR power down mode. Options are **Enabled** and Disabled.

**Power Down Mode**

This sets the power down mode. Options are **Channel** and Chip Select.

**8-DIMM Drive Strength**

Use this setting to Enable or **Disable** 8-DIMM Drive Strength.

**► ECC Configuration****ECC Mode**

This setting affects the DRAM scrub rate based on its setting. Options are **Disabled**, Basic, Good, Super, Max and User.

**DRAM ECC Enable**

DRAM ECC allows hardware to report and correct memory errors automatically. Options are Enabled and **Disabled**.

**DRAM Scrub Redirect**

Allows system to correct DRAM ECC errors immediately, even with background scrubbing on. Options are Enabled and **Disabled**.

**4-Bit ECC Mode**

Allows the user to enabled 4-bit ECC mode (also known as ECC Chipkill). Options are Enabled and **Disabled**.

**DRAM BG Scrub**

Corrects memory errors so later reads are correct. Options are **Disabled** and various times in nanoseconds and microseconds.

### **Data Cache BG Scrub**

Allows L1 cache RAM to be corrected when idle. Options are **Disabled** and various times in nanoseconds and microseconds.

### **L2 Cache BG Scrub**

Allows L2 cache RAM to be corrected when idle. Options are **Disabled** and various times in nanoseconds and microseconds.

### **L3 Cache BG Scrub**

Allows L3 cache RAM to be corrected when idle. Options are **Disabled** and various times in nanoseconds and microseconds.

## **▶ DRAM Timing Configuration**

### **Memory Clock Mode**

This setting specifies the memory clock mode. Options are **Auto**, Limit and Manual.

### **DRAM Timing Mode**

This setting specifies the DRAM timing mode. Options are **Auto** and DCT.

## **▶ IOMMU Option Menu**

### **IOMMU Mode**

Used to disable or set the GART size in systems without AGP. Options are **AGP Present**, Disabled, 32 MB, 64 MB, 128 MB, 256 MB, 512 MB and 1 GB.

### **Alternate VID**

Specify the alternate VID while in low power states. Options are **Auto** and various voltages from .800V to 1.050V in increments of .025V.

## **▶ SouthBridge/MCP55 Configuration**

### **CPU/LDT Spread Spectrum**

Enables spread spectrum for the CPU/LDT. Options are **Center Spread**, Down Spread or Disabled.

### **PCIE Spread Spectrum**

Allows you to **Enable** or Disable spread spectrum for PCI-Express.

**SATA Spread Spectrum**

Enables spread spectrum for the SATA. Options are **Enabled** and Disabled.

**USB 1.1 Controller**

Allows you to **Enable** or Disable the USB 1.1 controller.

**USB 2.0 Controller**

**Enable** or Disable the USB 2.0 controller.

**MAC0 LAN0**

Settings are **Auto** and Disabled for MAC0 LAN0.

**MAC0 LAN0 Bridge**

Settings are **Enabled** and Disabled for MAC0 LAN0 bridge.

**MAC1 LAN1**

Settings are **Auto** and Disabled for MAC1 LAN1.

**MAC1 LAN1 Bridge**

Settings are **Enabled** and Disabled for MAC1 LAN1 bridge.

**Legacy USB Support**

Select "Enabled" to enable the support for USB Legacy. Disable Legacy support if there are no USB devices installed in the system. "Auto" disabled Legacy support if no USB devices are connected. The options are Disabled, **Enabled** and Auto.

**► Processor & Clock Options****MTRR Mapping**

This determines the method used for programming CPU MTRRs when 4 GB or more memory is present. The options are **Continuous**, which makes the PCI hole non-cacheable, and Discrete, which places the PCI hole below the 4 GB boundary.

**Thermal Throttling**

Used to Enable or **Disable** thermal to generate a power management event.

**Power Now**

This setting is used to Enable or **Disable** the AMD Power Now feature.

**Secure Virtual Machine Mode**

This setting is used to **Enable** or Disable SVM.

## CPU Page Translation Table

This setting is used to **Enable** or Disable the CPU Page Translation Table.

### ► I/O Device Configuration

#### Serial Port1 Address

This option specifies the base I/O port address and Interrupt Request address of serial port 1. Select "Disabled" to prevent the serial port from accessing any system resources. When this option is set to *Disabled*, the serial port physically becomes unavailable. Select "3F8/IRQ4" to allow the serial port to use 3F8 as its I/O port address and IRQ 4 for the interrupt address. The options are Disabled, **3F8/IRQ4**, 3E8/IRQ4 and 2E8/IRQ3.

#### Serial Port2 Address

This option specifies the base I/O port address and Interrupt Request address of serial port 2. Select "Disabled" to prevent the serial port from accessing any system resources. When this option is set to "Disabled", the serial port physically becomes unavailable. Select "2F8/IRQ3" to allow the serial port to use 2F8 as its I/O port address and IRQ 3 for the interrupt address. The options are Disabled, **2F8/IRQ3**, 3E8/IRQ4 and 2E8/IRQ3.

### ► DMI Event Logging

#### View Event Log

Highlight this item and press <Enter> to view the contents of the event log.

#### Mark All Events as Read

Highlight this item and press <Enter> to mark all events as read.

#### Clear Event Log

Select Yes and press <Enter> to clear all event logs. The options are Yes and No to verify.

### ► Console Redirection

#### Remote Access

Allows you to Enable or **Disable** remote access. If enabled, the settings below will appear.

#### Serial Port Number

Selects the serial port to use for console redirection. Options are **COM1** and COM2.

#### **Serial Port Mode**

Selects the serial port settings to use. Options are **(115200 8, n, 1)**, (57600 8, n, 1), (38400 8, n, 1), (19200 8, n, 1) and (09600 8, n, 1).

#### **Flow Control**

Selects the flow control to be used for console redirection. Options are **None**, Hardware and Software.

#### **Redirection After BIOS POST**

Options are Disable (no redirection after BIOS POST), Boot Loader (redirection during POST and during boot loader) and **Always** (redirection always active). Note that some OS's may not work with this set to Always.

#### **Terminal Type**

Selects the type of the target terminal. Options are **ANSI**, VT100 and VT-UTF8.

#### **VT-UTF8 Combo Key Support**

Allows you to **Enable** or Disable VT-UTF8 combination key support for ANSI/VT100 terminals.

#### **Sredir Memory Display Delay**

Use this setting to set the delay in seconds to display memory information. Options are **No Delay**, 1 sec, 2 secs and 4 secs.

### ▶ **Hardware Monitor**

#### **CPU Overheat Alarm**

Use the "+" and "-" keys to set the CPU temperature threshold to between 65° and 90° C. When this threshold is exceeded, the overheat LED on the chassis will light up and an alarm will sound. The LED and alarm will turn off once the CPU temperature has dropped to 5 degrees below the threshold set. The default setting is **72° C**.

### ▶ **System Fan Monitor**

#### **Fan Speed Control**

This feature allows the user to determine how the system will control the speed of the onboard fans. Select "Workstation" if your system is used as a Workstation.

Select "Server" if your system is used as a Server. Select "Disable" to disable the fan speed control function to allow the onboard fans to continuously run at full speed (12V). The options are **1) Disable (Full Speed)** 2) 3-pin (Server) 3) 3-pin (Workstation).

### **FAN1 Speed through FAN8 Reading**

The speeds of the onboard fans (in rpm) are displayed here.

Other items in the submenu are systems monitor displays for the following information:

CPU1 Temperature, CPU2 Temperature (for 2U systems), System Temperature, VCoreA, VCoreB (for 2U systems), HT Voltage, CPU1 Mem VTT, CPU2 Mem VTT, CPU1 Mem, CPU2 Mem, 12V, 3.3V, VDD, 5V VSB, MCP55VCore, 1.5V and VBAT.

### **▶ IPMI Configuration**

#### **▶ View BMC System Event Log**

Pressing the Enter key will open the following settings. Use the "+" and "-" keys to navigate through the system event log.

#### **Clear BMC System Event Log**

Selecting this and pressing the Enter key will clear the BMC system event log.

#### **▶ Set LAN Configuration**

Use the "+" and "-" keys to choose the desired channel number.

##### **▶ IP Address**

Use the "+" and "-" keys to select the parameter. The IP address and current IP address in the BMC are shown.

##### **▶ MAC Address**

Use the "+" and "-" keys to select the parameter. The MAC address and current MAC address in the BMC are shown.

##### **▶ Subnet Mask**

Use the "+" and "-" keys to select the parameter. The subnet address and current subnet address in the BMC are shown.

### ► **Set PEF Configuration**

#### **PEF Support**

Use this setting to **Enable** or Disable PEF support. When enabled, the following settings will appear.

#### **PEF Action Global Control**

Options are **Alert**, Power Down, Reset Sysytem, Power Cycle, OEM Action and Diagnostic Int..

#### **Alert Startup Delay**

Use this setting to Enable or **Disable** the alert startup delay.

#### **Startup Delay**

Use this setting to Enable or **Disable** the startup delay.

#### **Event Message for PEF Action**

Use this setting to Enable or **Disable** event messages for a PEF action.

#### **BMC Watch Dog Timer Action**

This setting is used to set the Watch Dog function. The options are **Disabled**, Reset System, Power Down and Power Cycle.

## **4-4 Boot Menu**

The Boot Menu is accessible only when the "Load Onboard LAN Option ROM" setting (in the PCI/PnP Configuration menu) is enabled.

### ► **Boot Device Priority**

This feature allows the user to prioritize the boot sequence from the available devices.

### ► **Hard Disk Drives**

This feature allows the user to specify the boot sequence from available hard disk drives.

## 4-5 Security Menu

AMI BIOS provides a Supervisor and a User password. If you use both passwords, the Supervisor password must be set first.

### **Change Supervisor Password**

Select this option and press <Enter> to access the sub menu, and then type in the password.

### **Change User Password**

Select this option and press <Enter> to access the sub menu, and then type in the password.

### **Boot Sector Virus Protection**

This option is near the bottom of the Security Setup screen. Select "Disabled" to deactivate the Boot Sector Virus Protection. Select "Enabled" to enable boot sector protection. When "Enabled", AMI BIOS displays a warning when any program (or virus) issues a Disk Format command or attempts to write to the boot sector of the hard disk drive. The options are Enabled and **Disabled**.

## 4-6 Exit Menu

Select the Exit tab from AMI BIOS Setup Utility screen to enter the Exit BIOS Setup screen.

### **Save Changes and Exit**

When you have completed the system configuration changes, select this option to leave BIOS Setup and reboot the computer, so the new system configuration parameters can take effect. Select Save Changes and Exit from the Exit menu and press <Enter>.

### **Discard Changes and Exit**

Select this option to quit BIOS Setup without making any permanent changes to the system configuration and reboot the computer. Select Discard Changes and Exit from the Exit menu and press <Enter>.

### **Discard Changes**

Select this option and press <Enter> to discard all the changes and return to AMI BIOS Utility Program.

**Load Optimal Defaults**

To set this feature, select Load Optimal Defaults from the Exit menu and press <Enter>. Then Select "OK" to allow BIOS to automatically load the Optimal Defaults as the BIOS Settings. The Optimal settings are designed for maximum system performance, but may not work best for all computer applications.

**Load Fail-Safe Defaults**

To set this feature, select Load Fail-Safe Defaults from the Exit menu and press <Enter>. The Fail-Safe settings are designed for maximum system stability, but not maximum performance.

# Notes

## Appendix A

### BIOS Error Beep Codes

During the POST (Power-On Self-Test) routines, which are performed each time the system is powered on, errors may occur.

**Non-fatal errors** are those which, in most cases, allow the system to continue the boot-up process. The error messages normally appear on the screen.

**Fatal errors** are those which will not allow the system to continue the boot-up procedure. If a fatal error occurs, you should consult with your system manufacturer for possible repairs.

These fatal errors are usually communicated through a series of audible beeps. The numbers on the fatal error list (on the following page) correspond to the number of beeps for the corresponding error. All errors listed, with the exception of Beep Code 8, are fatal errors.

#### A-1 AMIBIOS Error Beep Codes

<b>Beep Code</b>	<b>Error Message</b>	<b>Description</b>
1 beep	Refresh	Circuits have been reset. (Ready to power up.)
5 short, 1 long	Memory error	No memory detected in system
1 long, 8 short	Video error	Video adapter disabled or missing

# Notes

## Appendix B

### BIOS POST Checkpoint Codes

When AMIBIOS performs the Power On Self Test, it writes checkpoint codes to I/O port 0080h. If the computer cannot complete the boot process, diagnostic equipment can be attached to the computer to read I/O port 0080h.

#### B-1 Uncompressed Initialization Codes

The uncompressed initialization checkpoint codes are listed in order of execution:

Checkpoint	Code Description
D0h	The NMI is disabled. Power on delay is starting. Next, the initialization code checksum will be verified.
D1h	Initializing the DMA controller, performing the keyboard controller BAT test, starting memory refresh and entering 4 GB flat mode next.
D3h	Starting memory sizing next.
D4h	Returning to real mode. Executing any OEM patches and setting the Stack next.
D5h	Passing control to the uncompressed code in shadow RAM at E000:0000h. The initialization code is copied to segment 0 and control will be transferred to segment 0.

## B-2 Bootblock Recovery Codes

The bootblock recovery checkpoint codes are listed in order of execution:

Checkpoint	Code Description
E0h	The onboard floppy controller if available is initialized. Next, beginning the base 512 KB memory test.
E1h	Initializing the interrupt vector table next.
E2h	Initializing the DMA and Interrupt controllers next.
E6h	Enabling the floppy drive controller and Timer IRQs. Enabling internal cache memory.
Edh	Initializing the floppy drive.
Eeh	Looking for a floppy diskette in drive A:.. Reading the first sector of the diskette.
Efh	A read error occurred while reading the floppy drive in drive A:..
F0h	Next, searching for the AMIBOOT.ROM file in the root directory.
F1h	The AMIBOOT.ROM file is not in the root directory.
F2h	Next, reading and analyzing the floppy diskette FAT to find the clusters occupied by the AMIBOOT.ROM file.
F3h	Next, reading the AMIBOOT.ROM file, cluster by cluster.
F4h	The AMIBOOT.ROM file is not the correct size.
F5h	Next, disabling internal cache memory.
FBh	Next, detecting the type of flash ROM.
FCh	Next, erasing the flash ROM.
FDh	Next, programming the flash ROM.
FFh	Flash ROM programming was successful. Next, restarting the system BIOS.

## B-3 Uncompressed Initialization Codes

The following runtime checkpoint codes are listed in order of execution.

These codes are uncompressed in F0000h shadow RAM.

Checkpoint	Code Description
03h	The NMI is disabled. Next, checking for a soft reset or a power on condition.
05h	The BIOS stack has been built. Next, disabling cache memory.
06h	Uncompressing the POST code next.
07h	Next, initializing the CPU and the CPU data area.
08h	The CMOS checksum calculation is done next.
0Ah	The CMOS checksum calculation is done. Initializing the CMOS status register for date and time next.
0Bh	The CMOS status register is initialized. Next, performing any required initialization before the keyboard BAT command is issued.
0Ch	The keyboard controller input buffer is free. Next, issuing the BAT command to the keyboard controller.
0Eh	The keyboard controller BAT command result has been verified. Next, performing any necessary initialization after the keyboard controller BAT command test.
0Fh	The initialization after the keyboard controller BAT command test is done. The keyboard command byte is written next.
10h	The keyboard controller command byte is written. Next, issuing the Pin 23 and 24 blocking and unblocking command.
11h	Next, checking if <End> or <Ins> keys were pressed during power on. Initializing CMOS RAM if the Initialize CMOS RAM in every boot AMIBIOS POST option was set in AMIBCP or the <End> key was pressed.
12h	Next, disabling DMA controllers 1 and 2 and interrupt controllers 1 and 2.
13h	The video display has been disabled. Port B has been initialized. Next, initializing the chipset.
14h	The 8254 timer test will begin next.
19h	Next, programming the flash ROM.
1Ah	The memory refresh line is toggling. Checking the 15 second on/off time next.
2Bh	Passing control to the video ROM to perform any required configuration before the video ROM test.
2Ch	All necessary processing before passing control to the video ROM is done. Looking for the video ROM next and passing control to it.
2Dh	The video ROM has returned control to BIOS POST. Performing any required processing after the video ROM had control
23h	Reading the 8042 input port and disabling the MEGAKEY Green PC feature next. Making the BIOS code segment writable and performing any necessary configuration before initializing the interrupt vectors.
24h	The configuration required before interrupt vector initialization has completed. Interrupt vector initialization is about to begin.

Checkpoint	Code Description
25h	Interrupt vector initialization is done. Clearing the password if the POST DIAG switch is on.
27h	Any initialization before setting video mode will be done next.
28h	Initialization before setting the video mode is complete. Configuring the monochrome mode and color mode settings next.
2Ah	Bus initialization system, static, output devices will be done next, if present. See the last page for additional information.
2Eh	Completed post-video ROM test processing. If the EGA/VGA controller is not found, performing the display memory read/write test next.
2Fh	The EGA/VGA controller was not found. The display memory read/write test is about to begin.
30h	The display memory read/write test passed. Look for retrace checking next.
31h	The display memory read/write test or retrace checking failed. Performing the alternate display memory read/write test next.
32h	The alternate display memory read/write test passed. Looking for alternate display retrace checking next.
34h	Video display checking is over. Setting the display mode next.
37h	The display mode is set. Displaying the power on message next.
38h	Initializing the bus input, IPL, general devices next, if present. See the last page of this chapter for additional information.
39h	Displaying bus initialization error messages. See the last page of this chapter for additional information.
3Ah	The new cursor position has been read and saved. Displaying the Hit <DEL> message next.
3Bh	The Hit <DEL> message is displayed. The protected mode memory test is about to start.
40h	Preparing the descriptor tables next.
42h	The descriptor tables are prepared. Entering protected mode for the memory test next.
43h	Entered protected mode. Enabling interrupts for diagnostics mode next.
44h	Interrupts enabled if the diagnostics switch is on. Initializing data to check memory wraparound at 0:0 next.
45h	Data initialized. Checking for memory wraparound at 0:0 and finding the total system memory size next.
46h	The memory wraparound test is done. Memory size calculation has been done. Writing patterns to test memory next.
47h	The memory pattern has been written to extended memory. Writing patterns to the base 640 KB memory next.
48h	Patterns written in base memory. Determining the amount of memory below 1 MB next.
49h	The amount of memory below 1 MB has been found and verified.
4Bh	The amount of memory above 1 MB has been found and verified. Checking for a soft reset and clearing the memory below 1 MB for the soft reset next. If this is a power on situation, going to checkpoint 4Eh next.

Checkpoint	Code Description
4Ch	The memory below 1 MB has been cleared via a soft reset. Clearing the memory above 1 MB next.
4Dh	The memory above 1 MB has been cleared via a soft reset. Saving the memory size next. Going to checkpoint 52h next.
4Eh	The memory test started, but not as the result of a soft reset. Displaying the first 64 KB memory size next.
4Fh	The memory size display has started. The display is updated during the memory test. Performing the sequential and random memory test next.
50h	The memory below 1 MB has been tested and initialized. Adjusting the displayed memory size for relocation and shadowing next.
51h	The memory size display was adjusted for relocation and shadowing.
52h	The memory above 1 MB has been tested and initialized. Saving the memory size information next.
53h	The memory size information and the CPU registers are saved. Entering real mode next.
54h	Shutdown was successful. The CPU is in real mode. Disabling the Gate A20 line, parity, and the NMI next.
57h	The A20 address line, parity, and the NMI are disabled. Adjusting the memory size depending on relocation and shadowing next.
58h	The memory size was adjusted for relocation and shadowing. Clearing the Hit <DEL> message next.
59h	The Hit <DEL> message is cleared. The <WAIT...> message is displayed. Starting the DMA and interrupt controller test next.
60h	The DMA page register test passed. Performing the DMA Controller 1 base register test next.
62h	The DMA controller 1 base register test passed. Performing the DMA controller 2 base register test next.
65h	The DMA controller 2 base register test passed. Programming DMA controllers 1 and 2 next.
66h	Completed programming DMA controllers 1 and 2. Initializing the 8259 interrupt controller next.
67h	Completed 8259 interrupt controller initialization.
7Fh	Extended NMI source enabling is in progress.
80h	The keyboard test has started. Clearing the output buffer and checking for stuck keys. Issuing the keyboard reset command next.
81h	A keyboard reset error or stuck key was found. Issuing the keyboard controller interface test command next.
82h	The keyboard controller interface test completed. Writing the command byte and initializing the circular buffer next.
83h	The command byte was written and global data initialization has completed. Checking for a locked key next.
84h	Locked key checking is over. Checking for a memory size mismatch with CMOS RAM data next.
85h	The memory size check is done. Displaying a soft error and checking for a password or bypassing WINBIOS Setup next.

Checkpoint	Code Description
86h	The password was checked. Performing any required programming before WINBIOS Setup next.
87h	The programming before WINBIOS Setup has completed. Uncompressing the WINBIOS Setup code and executing the AMIBIOS Setup or WINBIOS Setup utility next.
88h	Returned from WINBIOS Setup and cleared the screen. Performing any necessary programming after WINBIOS Setup next.
89h	The programming after WINBIOS Setup has completed. Displaying the power on screen message next.
8Ch	Programming the WINBIOS Setup options next.
8Dh	The WINBIOS Setup options are programmed. Resetting the hard disk controller next.
8Fh	The hard disk controller has been reset. Configuring the floppy drive controller next.
91h	The floppy drive controller has been configured. Configuring the hard disk drive controller next.
95h	Initializing the bus option ROMs from C800 next. See the last page of this chapter for additional information.
96h	Initializing before passing control to the adaptor ROM at C800.
97h	Initialization before the C800 adaptor ROM gains control has completed. The adaptor ROM check is next.
98h	The adaptor ROM had control and has now returned control to BIOS POST. Performing any required processing after the option ROM returned control.
99h	Any initialization required after the option ROM test has completed. Configuring the timer data area and printer base address next.
9Ah	Set the timer and printer base addresses. Setting the RS-232 base address next.
9Bh	Returned after setting the RS-232 base address. Performing any required initialization before the Coprocessor test next.
9Ch	Required initialization before the Coprocessor test is over. Initializing the Coprocessor next.
9Dh	Coprocessor initialized. Performing any required initialization after the Coprocessor test next.
9Eh	Initialization after the Coprocessor test is complete. Checking the extended keyboard, keyboard ID, and Num Lock key next. Issuing the keyboard ID command next.
A2h	Displaying any soft errors next.
A3h	The soft error display has completed. Setting the keyboard typematic rate next.
A4h	The keyboard typematic rate is set. Programming the memory wait states next.
A5h	Memory wait state programming is over. Clearing the screen and enabling parity and the NMI next.
A7h	NMI and parity enabled. Performing any initialization required before passing control to the adaptor ROM at E000 next.
A8h	Initialization before passing control to the adaptor ROM at E000h completed. Passing control to the adaptor ROM at E000h next.

---

---

Checkpoint	Code Description
A9h	Returned from adaptor ROM at E000h control. Performing any initialization required after the E000 option ROM had control next.
Aah	Initialization after E000 option ROM control has completed. Displaying the system configuration next.
Abh	Uncompressing the DMI data and executing DMI POST initialization next.
B0h	The system configuration is displayed.
B1h	Copying any code to specific areas.
00h	Code copying to specific areas is done. Passing control to INT 19h boot loader next.

# Notes