

SUPER  [®]

X9SPV-F
X9SPV-LN4F

USER'S MANUAL

Revision 1.0b

The information in this User's Manual has been carefully reviewed and is believed to be accurate. The vendor assumes no responsibility for any inaccuracies that may be contained in this document, makes no commitment to update or to keep current the information in this manual, or to notify any person or organization of the updates. **Please Note: For the most up-to-date version of this manual, please see our web site at www.supermicro.com.**

Super Micro Computer, Inc. ("Supermicro") reserves the right to make changes to the product described in this manual at any time and without notice. This product, including software and documentation, is the property of Supermicro and/or its licensors, and is supplied only under a license. Any use or reproduction of this product is not allowed, except as expressly permitted by the terms of said license.

IN NO EVENT WILL SUPER MICRO COMPUTER, INC. BE LIABLE FOR DIRECT, INDIRECT, SPECIAL, INCIDENTAL, SPECULATIVE OR CONSEQUENTIAL DAMAGES ARISING FROM THE USE OR INABILITY TO USE THIS PRODUCT OR DOCUMENTATION, EVEN IF ADVISED OF THE POSSIBILITY OF SUCH DAMAGES. IN PARTICULAR, SUPER MICRO COMPUTER, INC. SHALL NOT HAVE LIABILITY FOR ANY HARDWARE, SOFTWARE, OR DATA STORED OR USED WITH THE PRODUCT, INCLUDING THE COSTS OF REPAIRING, REPLACING, INTEGRATING, INSTALLING OR RECOVERING SUCH HARDWARE, SOFTWARE, OR DATA.

Any disputes arising between manufacturer and customer shall be governed by the laws of Santa Clara County in the State of California, USA. The State of California, County of Santa Clara shall be the exclusive venue for the resolution of any such disputes. Supermicro's total liability for all claims will not exceed the price paid for the hardware product.

FCC Statement: This equipment has been tested and found to comply with the limits for a Class B digital device pursuant to Part 15 of the FCC Rules. These limits are designed to provide reasonable protection against harmful interference in a residential installation. This equipment generates, uses, and can radiate radio frequency energy and, if not installed and used in accordance with the manufacturer's instruction manual, may cause interference with radio communications. However, there is no guarantee that interference will not occur in a particular installation. If this equipment does cause harmful interference to radio or television reception, which can be determined by turning the equipment off and on, you are encouraged to try to correct the interference by one or more of the following measures:

- Reorient or relocate the receiving antenna.
- Increase the separation between the equipment and the receiver.
- Connect the equipment into an outlet on a circuit different from that to which the receiver is connected.
- Consult the dealer or an experienced radio/television technician for help.

California Best Management Practices Regulations for Perchlorate Materials: This Perchlorate warning applies only to products containing CR (Manganese Dioxide) Lithium coin cells. "Perchlorate Material-special handling may apply. See www.dtsc.ca.gov/hazardouswaste/perchlorate".

WARNING: Handling of lead solder materials used in this product may expose you to lead, a chemical known to the State of California to cause birth defects and other reproductive harm.

Manual Revision 1.0b

Release Date: August 13, 2014

Unless you request and receive written permission from Super Micro Computer, Inc., you may not copy any part of this document. Information in this document is subject to change without notice. Other products and companies referred to herein are trademarks or registered trademarks of their respective companies or mark holders.

Copyright © 2014 by Super Micro Computer, Inc. All rights reserved.
Printed in the United States of America

Preface

About This Manual

This manual is written for system integrators, IT technicians and knowledgeable end users. It provides information for the installation and use of the **SUPER**® X9SPV motherboard product series. This product is intended to be professionally installed and serviced by a technician.

About This Motherboard

The X9SPV motherboard series is a value-driven product aimed at users who demand a small form-factor, ultra low-power motherboard for PC, gateway server or embedded applications.

The X9SPV motherboard series features a mobile, 3rd generation Intel® Core™ i7/i5/i3 processor onboard with an FCBGA1023 package, offering many features such as two ECC SO-DIMM memory support, four SATA 2.0 ports, two SATA 3.0 ports, an on-board VGA with Intel HD 4000 graphics option. It also includes 4 LAN ports (X9SPV-LN4F), IPMI 2.0, Disk on Module, and TPM support. These enable the X9SPV motherboard series to deliver an energy-efficient, low power, high performance platform, in a small form-factor.

Manual Organization

Chapter 1 describes the features, specifications and performance of the mainboard and provides detailed information about the chipset.

Chapter 2 provides hardware installation instructions. Read this chapter when installing the processor, memory modules and other hardware components into the system. If you encounter any problems, see **Chapter 3**, which describes troubleshooting procedures for video, memory and system setup stored in the CMOS.

Chapter 4 includes an introduction to the BIOS and provides detailed information on running the CMOS Setup utility.

Appendix A provides BIOS Error Beep Codes.

Appendix B lists Driver Installation Instructions.

Appendix C provides the UEFI BIOS Recovery Instructions.

Conventions Used in the Manual:

Special attention should be given to the following symbols for proper installation and to prevent damage done to the components or injury to yourself:



Danger/Caution: Instructions to be strictly followed to prevent catastrophic system failure or to avoid bodily injury



Warning: Critical information to prevent damage to the components or data loss.



Important: Important information given to ensure proper system installation or to relay safety precautions.



Note: Additional Information given to differentiate various models or provides information for correct system setup.

Contacting Supermicro

Headquarters

Address: Super Micro Computer, Inc.
980 Rock Ave.
San Jose, CA 95131 U.S.A.

Tel: +1 (408) 503-8000

Fax: +1 (408) 503-8008

Email: marketing@supermicro.com (General Information)
support@supermicro.com (Technical Support)

Web Site: www.supermicro.com

Europe

Address: Super Micro Computer B.V.
Het Sterrenbeeld 28, 5215 ML
's-Hertogenbosch, The Netherlands

Tel: +31 (0) 73-6400390

Fax: +31 (0) 73-6416525

Email: sales@supermicro.nl (General Information)
support@supermicro.nl (Technical Support)
rma@supermicro.nl (Customer Support)

Web Site: www.supermicro.nl

Asia-Pacific

Address: Super Micro Computer, Inc.
3F, No. 150, Jian 1st Rd.
Zhonghe Dist., New Taipei City 235
Taiwan (R.O.C)

Tel: +886-(2) 8226-3990

Fax: +886-(2) 8226-3992

Email: support@supermicro.com.tw

Web Site: www.supermicro.com.tw

Table of Contents

Preface

About This Manual	iii
About This Motherboard	iii
Manual Organization	iii
Conventions Used in the Manual:	iv
Contacting Supermicro	v

Chapter 1 Introduction

1-1 Overview	1-1
Checklist	1-1
SUPER X9SPV-F/LN4F Image	1-2
X9SPV-F/LN4F Motherboard Layout	1-3
X9SPV-F/LN4F Quick Reference	1-4
Ports, LEDs, and Connectors	1-5
Jumper Descriptions	1-5
Motherboard Features	1-6
X9SPV Motherboard Series Block Diagram	1-8
1-2 Chipset Overview	1-9
1-3 PC Health Monitoring	1-10
Recovery from AC Power Loss	1-10
Onboard Voltage Monitoring	1-10
Fan Status Monitor with Software	1-10
1-4 Power Configuration Settings	1-11
Slow Blinking LED for Suspend-State Indicator	1-11
BIOS Support for USB Keyboard	1-11
Main Switch Override Mechanism	1-11
1-5 Power Supply	1-11
1-6 Super I/O	1-12

Chapter 2 Installation

2-1 Static-Sensitive Devices	2-1
Precautions	2-1
Unpacking	2-1
Tools Needed	2-2
Location of Mounting Holes	2-2
2-2 Motherboard Installation	2-2
Installation Instructions	2-3
2-3 System Memory	2-4

	How to Install SO DIMMs	2-4
	Memory Support.....	2-4
	The SO DIMM Socket.....	2-5
2-4	Connectors/I/O Ports.....	2-6
	Back Panel Connectors and I/O Ports.....	2-6
	PS/2 KB/Mouse Port (KB/Mouse).....	2-7
	Universal Serial Bus (USB).....	2-8
	Serial Ports (COM1/COM2).....	2-9
	VGA Connector (VGA).....	2-10
	LAN Ports (LAN1~LAN4).....	2-11
	Front Control Panel.....	2-12
	JF1 Header Pins	2-12
	Front Control Panel Pin Definitions.....	2-13
	Power LED	2-13
	HDD LED.....	2-13
	NIC1/NIC2 LED Indicators	2-13
	Overheat (OH)/Fan Fail LED.....	2-14
	Power Fail LED	2-14
	NMI Button	2-14
	Reset Button	2-15
	Power Button	2-15
2-5	Connecting Cables.....	2-16
	ATX Power Connector (JPW1)	2-16
	Fan Headers.....	2-17
	Chassis Intrusion (JL1)	2-18
	TPM Header (JTPM1).....	2-18
	SATA DOM Power (JSD1).....	2-19
	Power SMB I ² C Connector (JPI2C1)	2-19
	System Management Bus (JIPMB1).....	2-19
	T-SGPIO Headers (T-SGPIO1/2).....	2-20
	Overheat/Fan Fail LED (JOH1).....	2-20
	Power LED/Speaker (JD1).....	2-21
	Internal Speaker/Buzzer (SP1)	2-21
2-6	Jumper Settings	2-22
	Explanation of Jumpers.....	2-22
	BMC Enable/Disable (JPB1).....	2-23
	BIOS Write Protect (JWP1).....	2-23
	CMOS Clear (JBT1).....	2-24
	USB Wake-Up (JUSB1).....	2-25

	Watch Dog Reset (JWD1).....	2-26
2-7	Onboard Indicators.....	2-27
	LAN Port LEDs.....	2-27
	Standby Power LED (LED1)	2-28
	IPMI Heartbeat LED (LED2).....	2-28
	Overheat / Fan Fail (LED3).....	2-28
2-8	Serial ATA and HDD Connections.....	2-29
	SATA Connections (SATA1~SATA6)	2-29

Chapter 3 Troubleshooting

3-1	Troubleshooting Procedures	3-1
	Before Power On	3-1
	No Power	3-1
	No Video	3-1
	Memory Errors	3-2
	If You Lose the System's Setup Configuration	3-2
3-2	Technical Support Procedures	3-2
3-3	Frequently Asked Questions.....	3-3
3-4	Returning Merchandise for Service.....	3-5

Chapter 4 BIOS

4-1	Introduction.....	4-1
	Starting BIOS Setup Utility.....	4-1
	How To Change the Configuration Data	4-1
	How to Start the Setup Utility	4-2
4-2	Main Setup.....	4-2
	System Overview: The following BIOS information will be displayed:.....	4-3
	System Time/System Date	4-3
	Supermicro X9SPV-F/LN4F.....	4-3
	Processor	4-3
	System Memory	4-3
4-3	Advanced Setup Configurations.....	4-4
	▶BOOT Feature.....	4-4
	Quiet Boot	4-4
	Option ROM Display Messages.....	4-4
	Bootup Num-Lock.....	4-4
	Wait For 'F1' If Error.....	4-5
	INT19 Trap Response	4-5
	Watch Dog Function.....	4-5
	Power Button Function.....	4-5

Restore on AC Power Loss.....	4-5
▶Processor and Clock Options.....	4-5
Hyper Threading.....	4-5
Active Processor Cores.....	4-6
Limit CPUID Maximum.....	4-6
Execute-Disable Bit (Available when supported by the OS and the CPU).....	4-6
Intel® Virtualization Technology (Available when supported by the CPU).....	4-6
Hardware Prefetcher (Available when supported by the CPU).....	4-6
Adjacent Cache Line Prefetch (Available when supported by the CPU).....	4-6
Clock Spread Spectrum.....	4-6
▶CPU PPM Configuration.....	4-7
Power Technology.....	4-7
EIST.....	4-7
Turbo Mode.....	4-7
CPU C3 Report, CPU C6 Report.....	4-7
Config TDP LOCK.....	4-7
Long Duration Power Limit.....	4-7
Long Duration Maintained.....	4-7
Short Duration Power Limit.....	4-7
ACPI T State.....	4-7
▶Advanced Chipset Control.....	4-8
▶IDE/SATA Configuration.....	4-11
SATA Controllers.....	4-11
SATA Mode Selection.....	4-11
IDE Mode.....	4-11
Serial ATA Port 0~5.....	4-11
AHCI Mode.....	4-11
Aggressive LPM Support.....	4-11
Serial ATA Port 0~5 Hot Plug.....	4-11
Serial ATA Port 0~5 Spin Up Device.....	4-11
RAID Mode.....	4-12
Serial ATA Port 0~5 Hot Plug.....	4-12
Serial ATA Port 0~5 Spin Up Device.....	4-12
▶PCIe/PCI/PnP Configuration.....	4-12
Launch PXE, Storage, Video OpROM Policy.....	4-12
Other PCI device ROM priority.....	4-12
PCI Latency Timer.....	4-12

PERR# Generation.....	4-12
SERR# Generation.....	4-12
ASPM Support.....	4-12
Maximum Payload.....	4-13
Maximum Read Request.....	4-13
Above 4G Decoding.....	4-13
VGA Palette Snoop.....	4-13
PCI-E Slot 1 Option ROM.....	4-16
Onboard LAN Option ROM Select.....	4-16
Onboard LAN 1 ~ LAN 4.....	4-16
Load Onboard LAN 1 ~ LAN 4 Option ROM.....	4-16
Network Stack.....	4-16
▶ Super IO Device Configuration.....	4-17
▶ Serial Port 1 Configuration / Serial Port 2 Configuration.....	4-17
Serial Port 1 / Serial Port 2.....	4-17
Serial Port 1 Settings / Serial Port 2 Settings.....	4-17
▶ Remote Access Configuration.....	4-18
Serial Port for Out-of-Band Management/Windows Emergency Management Services (EMS).....	4-19
Console Redirection (for EMS).....	4-19
▶ ACPI Configuration.....	4-20
High Precision Timer.....	4-20
▶ Trusted Computing Configuration.....	4-21
Security Device Support.....	4-21
▶ Intel TXT(LT) Configuration.....	4-21
Secure Mode Extensions (SMX).....	4-21
Intel TXT (LT) Support.....	4-21
iSCSI Configuration.....	4-21
iSCSI Initiator Name.....	4-21
Add an Attempt.....	4-22
Intel(R) 82579LM / Intel(R) 82574L Gigabit Network Connection.....	4-23
▶ NIC Configuration.....	4-23
Link Speed.....	4-23
Wake On LAN.....	4-23
Blink LEDs (Range 0-15 seconds).....	4-23
Port Configuration Information.....	4-23
4-4 Event Logs.....	4-23
▶ Change SmbIOS Event Log Settings.....	4-24

	Smbios Event Log	4-24
	Erase Event Log	4-24
	When Log is Full	4-24
	Log System Boot Event	4-24
	MECI.....	4-24
	METW.....	4-24
	View SmBIOS Event Log	4-24
4-5	IPMI Settings.....	4-25
	▶System Event Log	4-25
	When SEL Full	4-25
	Log EFI Status Codes.....	4-26
	▶BMC Network Configuration.....	4-26
	Update IPMI LAN Configuration.....	4-26
	Configuration Source.....	4-26
4-6	Boot.....	4-27
	Setup Prompt Timeout	4-27
	Boot Options Priorities	4-27
	Boot Option #1, Boot option #2, Boot Option #3, etc.....	4-27
	USB Device BBS Priorities	4-27
	Network Devices	4-27
	▶Delete Boot Option.....	4-27
4-7	Security Settings	4-28
	Administrator Password	4-28
	User Password:	4-28
	HDD Password:.....	4-28
4-8	Exit	4-29
	Discard Changes and Exit	4-29
	Save Changes and Reset	4-29
	Discard Changes.....	4-29
	Restore Defaults.....	4-30
	Save As User Defaults	4-30
	Restore User Defaults.....	4-30
	Boot Override	4-30
	IBA IGE Slot 0100 v1381	4-30
	UEFI: Built-in EFI Shell	4-30
	Me FW Image Re-Flash.....	4-30

Appendix A POST Error Beep Codes

Recoverable POST Error Beep CodesA-1

Appendix B Software Installation Instructions

B-1 Installing Drivers.....B-1

B-2 Configuring SuperDoctor[®] III.....B-2

Appendix C UEFI BIOS Recovery Instructions

C-1 An Overview to the UEFI BIOSC-1

C-2 How to Recover the UEFI BIOS Image (-the Main BIOS Block).....C-1

C-3 To Recover the Boot Sector Using a USB-Attached DeviceC-1

Chapter 1

Introduction

1-1 Overview

Checklist

Congratulations on purchasing your computer motherboard from an acknowledged leader in the industry. Supermicro boards are designed with the utmost attention to detail and to provide you with the highest standards in quality and performance.

Please check that the following items have all been included with your motherboard. If anything listed here is damaged or missing, contact your retailer.

All the following items are included in the retail box only.

- One (1) Supermicro Motherboard with CPU and Heatsink installed
- Two (2) SATA cables
- One (1) I/O shield

SUPER X9SPV-F/LN4F Image

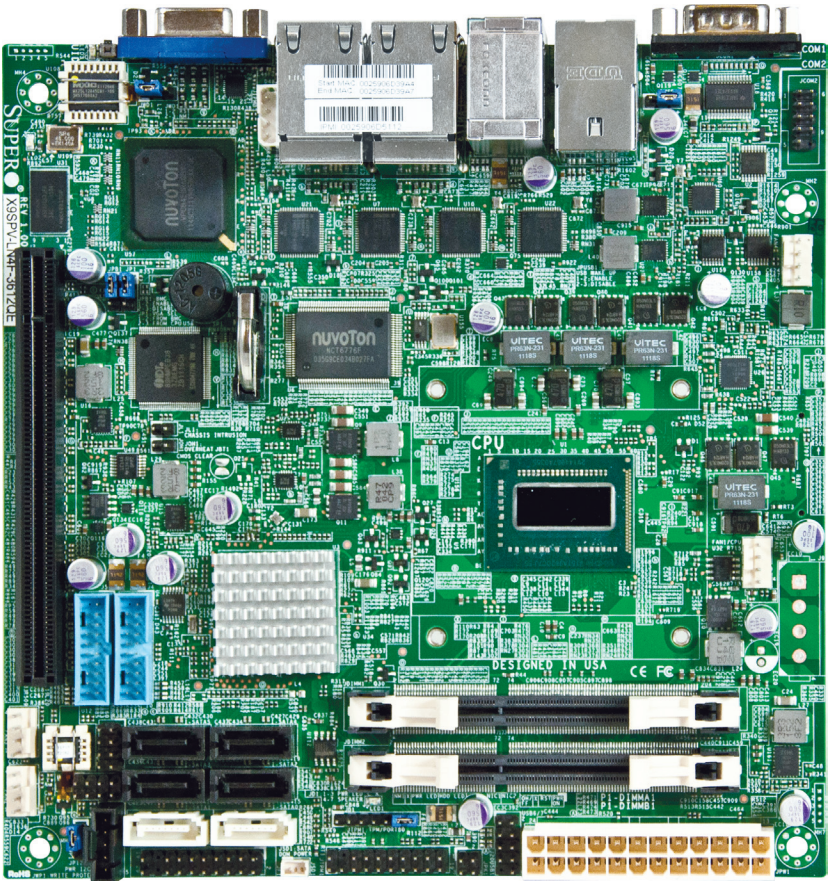

Note: All graphics and images shown in this manual were based upon the latest PCB Revision available at the time of publishing of the manual. The motherboard you've received may or may not look exactly the same as the image shown in this manual.

X9SPV-F/LN4F Motherboard Layout

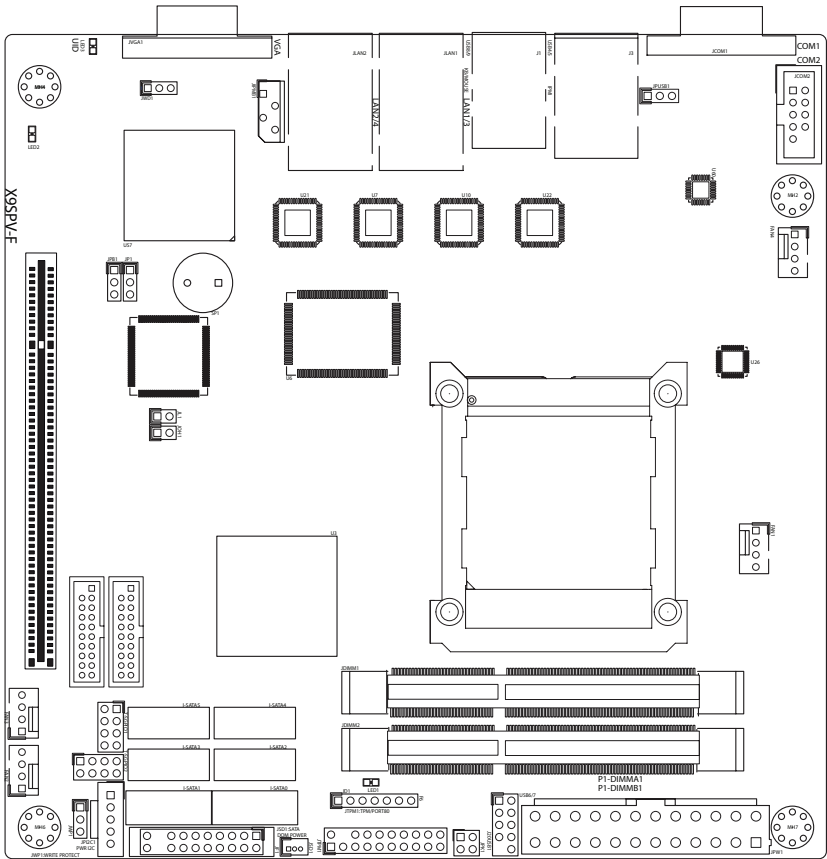

Important Notes to the User

- Jumpers not indicated are for testing only.
- See Chapter 2 for detailed information on jumpers, I/O ports and JF1 front panel connections.
- "□" indicates the location of "Pin 1".

X9SPV-F/LN4F Quick Reference

(not drawn to scale)

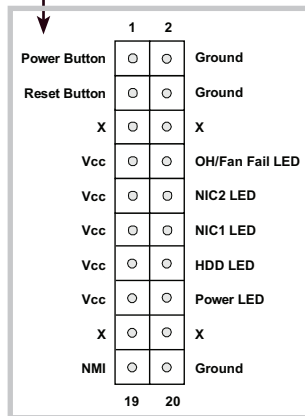
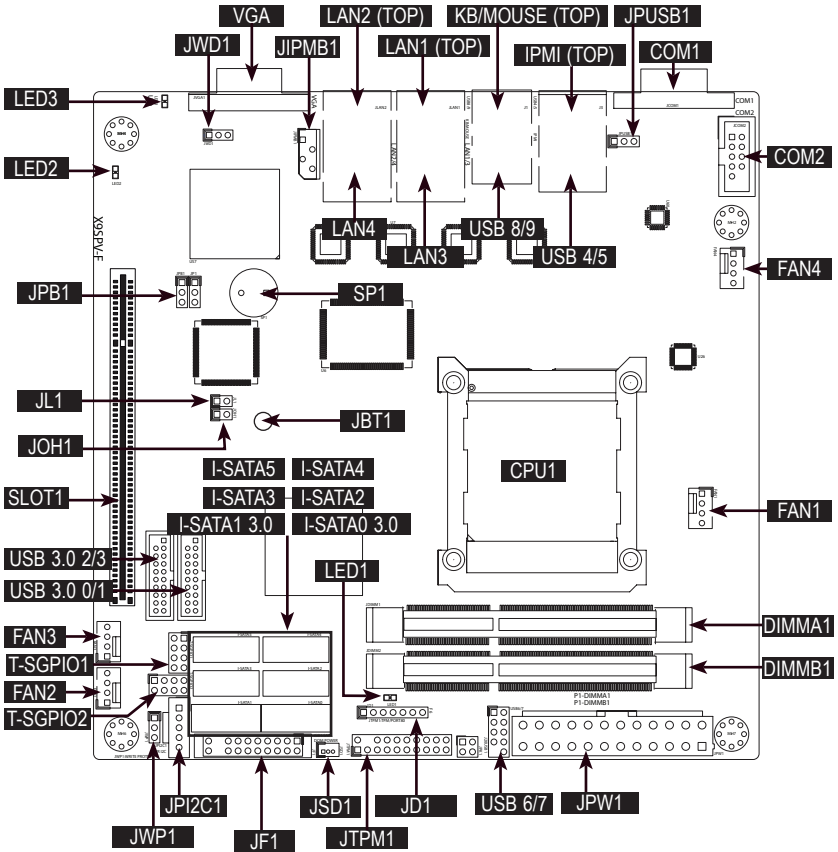

Ports, LEDs, and Connectors

Connectors/LED	Description
LED1	Standby Power LED
LED2	IPMI Heartbeat LED
LED3	Unsupported Memory LED
SLOT1	PCI-E x16 Gen 2 Slot
JL1	Chassis Intrusion Header
JOH1	Overheat LED
USB 0/1, USB 2/3	USB 3.0 Headers
USB 6/7	USB 2.0 Header
USB 4/5, USB 8/9	Backpanel USB Ports
FAN1~4	CPU Fan, System Fan and Auxilliary Fan Headers
T-SGPIO1, T-SGPIO2	Serial General Purpose I/O headers
JPI2C1	JPI2C, PWR supply (I2C) System Management Bus
JF1	Front Panel Control Header
JSD1	DOM (Disk on Module) Power Connector
JTPM1	TPM Header
SP1	Onboard Speaker/Buzzer
JD1	Power LED/Speaker Header
I-SATA1~I-SATA6	SATA Connectors (White connectors: SATA 3, Black: SATA 2)
JPW1	24-Pin ATX Power Connector
DIMMA1, DIMMB1	SODIMM Memory Sockets
COM1, COM2	Serial Port 1 (COM1) on the Backpanel, Serial Port 2 (COM2) Header
IPMI	IPMI Port
KB/MOUSE	Combination PS/2 Keyboard or Mouse Port
LAN1, LAN2	LAN1, LAN2 Gb Ethernet Ports
LAN3, LAN4	LAN3, LAN4 Gb Ethernet Ports (X9SPV-LN4F only)
VGA	VGA Port
JIPMB1	4-pin External BMC I2C Header (for an IPMI card)
CPU1	CPU / Processor

Jumper Descriptions

Jumper	Description	Default Setting
JPB1	BMC (IPMI) Enable/Disable	Pins 1-2 (Enabled)
JBT1	CMOS Clear	Open (Short pads to clear)
JWD1	Watch Dog Timer	Pins 1-2 (Reset)
JWP1	BIOS Write Protect	Pins 1-2 (Enabled)
JUSB1	USB Wake-up	Pins 1-2 (Enabled)

Motherboard Features

CPU	Onboard, Mobile, 3rd generation Intel® Core™ i7/i5/i3 processor (FCBGA1023)	
Memory	Two (2) SO-DIMM slots support up to 16 GB of DDR3, unbuffered, 1066/1333 MHz, ECC SO-DIMM memory	
	Supports One DIMM per Channel	
	DIMM sizes	
	ECC SO-DIMM	2 GB, 4 GB and 8GB
Chipset	Mobile Intel® QM77 Express (3.9W)	
Expansion Slots	One (1) PCI-E x 16, Gen 3 Slot (i3 with Gen 2 only)	
Graphics	Intel HD 4000 Integrated Graphics	
	Matrox G200eW Graphics	
Network Connections	Four (4) RJ-45 Rear I/O Panel Connectors (Intel 82574L) on the X9SPV-LN4F only	
	Two (2) RJ-45 Rear I/O Panel Connectors (Intel 82574L) on the X9SPV-F only	
	One (1) RJ-45 IPMI Connector	
I/O Devices	SATA Connections	
	SATA 3.0 Ports	Two (2) (SATA 0/1)
		RAID 0, 1 Support
	SATA 2.0 Ports	Four (4) (SATA 2~5)
		RAID 0, 1, 5, 10
	USB Devices	
	Four (4) USB 2.0 ports on the rear I/O panel (USB 4/5, 8/9)	
	Six (6) USB ports on headers for front panel access: USB0/1 (3.0), USB 2/3 (3.0), USB 6/7 (2.0)	
	Graphics	
	One (1) Back panel VGA port	
	Keyboard/Mouse	
	Combination PS/2 Keyboard/Mouse port on the I/O backpanel	
	Serial (COM) Ports	
	Two (2) Fast UART 16550 connections: one 9-pin RS-232 port (Backpanel COM1 port) and one header (COM2)	
	Super I/O	
	Winbond Super I/O NCT6776F	

	IPMI 2.0
	Nuvoton WPCM450 BMC
BIOS	16 MB SPI AMI BIOS® SM Flash BIOS
	Plug and Play, ACPI 1.0/2.0/3.0, USB Keyboard and SMBIOS 2.3
Power	ACPI/ACPM Power Management
	Main Switch Override Mechanism
	Suspend-To-RAM (STR)
	One (1) Disk-On-Module (DOM) Power Connector
	Power-on mode for AC power recovery
PC Health Monitoring	CPU Monitoring
	Onboard voltage monitors for CPU core, 1.8V, +3.3V, +5V, +/-12V, +3.3V Stdby, +5V Stdby, VBAT, HT, Memory, Chipset
	Tachometer Monitoring
	CPU & chassis environment Monitoring
	CPU Thermal Trip support
	Thermal Monitor (TM1) support
	Fan Control
	Fan status monitoring with firmware 4-pin (Pulse Width Modulation) fan speed control
	Low noise fan speed control
System Management	PECI (Platform Environment Configuration Interface) 2.0 support
	System resource alert via SuperDoctor® III
	SuperDoctor® III, Watch Dog, NMI
	Chassis Intrusion header and detection
CD Utilities (Download from Website)	BIOS flash upgrade utility
	Drivers and software for Intel® QM77 Express chipset utilities
Other	ROHS 6/6 (Full Compliance)
	One (1) TPM 1.2 Header
Dimensions	Mini-ITX form factor (6.7" x 6.7")

Motherboard Features Table

Model/PN	3rd Gen IVB ECC	Base Freq	Turbo (1C/DC/QC) GHz	Core/Thread
X9SPV-LN4F-3QE	i7-3612QE	2.1	3.1/3.0/2.8	4C/8T
X9SPV-LN4F-3LE	i7-3555LE	2.5	3.2/3.1/NA	2C/4T
X9SPV-F-3610ME	i5-3610ME	2.7	3.3/3.1/NA	2C/4T
X9SPV-F-3217UE	i3-3217UE	1.6	NA/NA/NA	2C/4T

Model/PN	TDP	Cache	PCIex16	TXT	VT-d	VT-X	AES-NI
X9SPV-LN4F-3QE	35W	6MB	Gen3	Y	Y	Y	Y
X9SPV-LN4F-3LE	25W	4MB	Gen3	Y	Y	Y	Y
X9SPV-F-3610ME	35W	3MB	Gen3	Y	Y	Y	Y
X9SPV-F-3217UE	17W	3MB	Gen2	N	N	Y	N

1-2 Chipset Overview

The X9SPV Motherboard Series supports a single on board, 3rd generation Intel® Core™ i7/i5/i3 processor (FCBGA1023 Mobile ECC CPU).

Built around the functionality and the capability of the Intel® QM77 Express chipset, the motherboard provides substantial system performance and storage capability for performance platforms in a compact package.

The Intel QM77 Express chipset is part of the mobile Intel Chipset family, with a single-chip architecture. Among its features are

- 3.9W Power Consumption
- Intel Anti-Theft Technology
- SATA Controller (up to 6G/s)
- Smart Response Technology (SSD Cache)

For more information regarding the Intel QM77 Express chipset, please visit Intel's website at: <http://www.intel.com>

1-3 PC Health Monitoring

This section describes the PC health monitoring features of the X9SPV Motherboard Series. These motherboards have an onboard System Hardware Monitor chip that supports PC health monitoring.

Recovery from AC Power Loss

BIOS provides a setting for you to determine how the system will respond when AC power is lost and then restored to the system. You can choose for the system to remain powered off (in which case you must hit the power switch to turn it back on) or for it to automatically return to a power on state. See the Power Lost Control setting in the BIOS chapter of this manual to change this setting. The default setting is **Last State**.

Onboard Voltage Monitoring

The onboard voltage monitor will scan the following voltages continuously: CPU core, 1.8V, +3.3V, +5V, +/-12V, +3.3V Stdbv, +5V Stdbv, VBAT, HT, Memory, Chipset. Once a voltage becomes unstable, it will give a warning or send an error message to the screen. The User can adjust the voltage thresholds to define the sensitivity of the voltage monitor by using SD III.

Fan Status Monitor with Software

The PC health monitor can check the RPM status of the cooling fans via Supero Doctor III.

1-4 Power Configuration Settings

This section describes features of your motherboard that deal with power and power settings.

Slow Blinking LED for Suspend-State Indicator

When the CPU goes into a suspend state, the chassis power LED will start blinking to indicate that the CPU is in suspend mode. When the user presses any key, the CPU will wake up and the LED will automatically stop blinking and remain on.

BIOS Support for USB Keyboard

If the USB keyboard is the only keyboard in the system, it will function like a normal keyboard during system boot-up.

Main Switch Override Mechanism

When an ATX power supply is used, the power button can function as a system suspend button. When the user presses the power button, the system will enter a Soft Off state. The monitor will be suspended and the hard drive will spin down. Pressing the power button again will cause the whole system to wake up. During the SoftOff state, the ATX power supply provides power to keep the required circuitry in the system "alive." In case the system malfunctions and you want to turn off the power, just press and hold the power button for 4 seconds. The power will turn off and no power will be provided to the motherboard.

1-5 Power Supply

As with all computer products, a stable power source is necessary for proper and reliable operation. It is even more important for processors that have high CPU clock rates of 1 GHz and faster.

The SUPER[®] X9SPV Motherboard Series accommodates 12V ATX power supplies. Although most power supplies generally meet the specifications required by the CPU, some are inadequate. A 2-Amp of current supply on a 5V Standby rail is strongly recommended.

1-6 Super I/O

The Super I/O provides two high-speed, 16550 compatible serial communication ports (UARTs). Each UART includes a 16-byte send/receive FIFO, a programmable baud rate generator, complete modem control capability and a processor interrupt system. Both UARTs provide legacy speed with baud rate of up to 115.2 Kbps as well as an advanced speed with baud rates of 250 K, 500 K, or 1 Mb/s, which support higher speed modems.

The Super I/O provides functions that comply with ACPI (Advanced Configuration and Power Interface), which includes support of legacy and ACPI power management through a SMI or SCI function pin. It also features auto power management to reduce power consumption.

Notes

Chapter 2

Installation

2-1 Static-Sensitive Devices



Electrostatic-Discharge (ESD) can damage electronic components. To prevent damage to your system board, it is important to handle it very carefully. The following measures are generally sufficient to protect your equipment from ESD.



Precautions

- Use a grounded wrist strap designed to prevent static discharge.
- Touch a grounded metal object before removing the board from the antistatic bag.
- Handle the board by its edges only; do not touch its components, peripheral chips, memory modules or gold contacts.
- When handling chips or modules, avoid touching their pins.
- Put the motherboard and peripherals back into their antistatic bags when not in use.
- For grounding purposes, make sure your computer chassis provides excellent conductivity between the power supply, the case, the mounting fasteners and the motherboard.
- Use only the correct type of onboard CMOS battery. Do not install the onboard upside down battery to avoid possible explosion.

Unpacking

The motherboard is shipped in antistatic packaging to avoid static damage. When unpacking the board, make sure the person handling it is static protected.

2-2 Motherboard Installation

All motherboards have standard mounting holes to fit different types of chassis. Make sure that the locations of all the mounting holes for both motherboard and chassis match. Although a chassis may have both plastic and metal mounting fasteners, metal ones are highly recommended because they ground the motherboard to the chassis. Make sure that the metal standoffs click in or are screwed in tightly. Then use a screwdriver to secure the motherboard onto the motherboard tray.



Caution: Some components are very close to the mounting holes. Please take precautionary measures to prevent damage to these components when installing the motherboard to the chassis.

Tools Needed

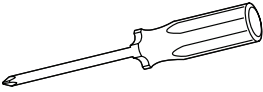

Phillips Screwdriver



Pan head screws (4 pieces)



Stand Offs (4 pieces)
(Only if needed)



Note: The above items are not provided with this motherboard.

Location of Mounting Holes

There are four (4) mounting holes on the X9SPV motherboard series.

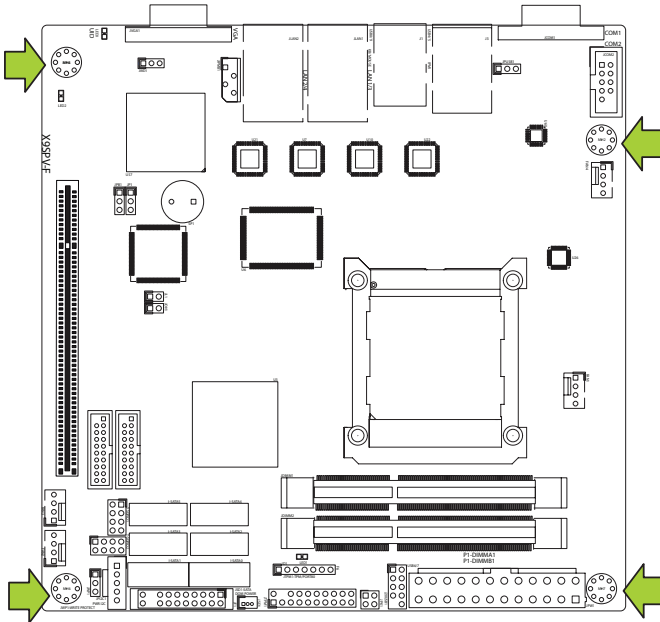



Caution: To avoid damaging the motherboard and its components, please do not use a force greater than 8 lb/inch on each mounting screw during motherboard installation.

Installation Instructions

- 1** Install the I/O shield into the chassis.

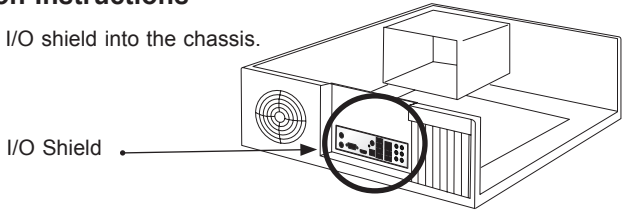

- 2** Locate the mounting holes on the motherboard. Refer to the layout on the previous page for mounting hole locations.

- 3** Locate the matching mounting holes on the chassis. Install standoffs in the chassis as needed. Align the mounting holes on the motherboard against the mounting holes on the chassis.

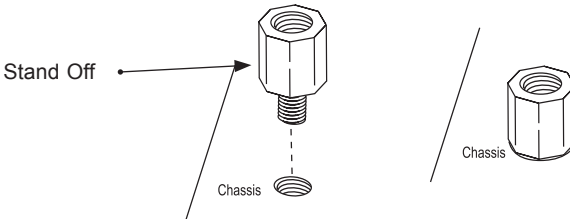

- 4** Install the motherboard into the chassis carefully to avoid damage to motherboard components.

- 5** Insert a Pan head #6 screw into a mounting hole on the motherboard and its matching mounting hole on the chassis, using the Philips screwdriver.

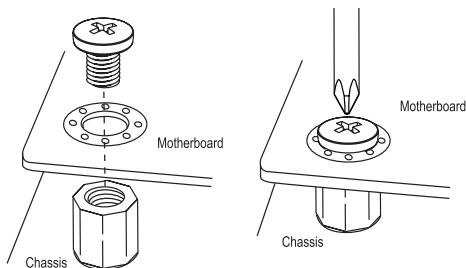

- 6** Repeat Step 4 to insert #6 screws to all mounting holes.

- 7** Make sure that the motherboard is securely placed on the chassis.

2-3 System Memory



CAUTION

Exercise extreme care when installing or removing DIMM modules to prevent any possible damage.



Note: Check the Supermicro website for a list of memory modules that have been validated with the X9SPV motherboard series.

How to Install SO DIMMs

1. Insert the desired number of SO DIMMs into the memory slots, starting with DIMMA1, then DIMMB1. Pay attention to the notch along the bottom of the module to prevent incorrect DIMM module installation.
2. Insert each SO DIMM module vertically and snap it into place. Repeat step 1 to install DIMMB1 if needed. See instructions on the next page.

Memory Support

The X9SPV Motherboard Series supports up to 16GB of DDR3 ECC SODIMMs (1066/1333 MHz in 2 SODIMM slots).

Installing and Removing DIMMs

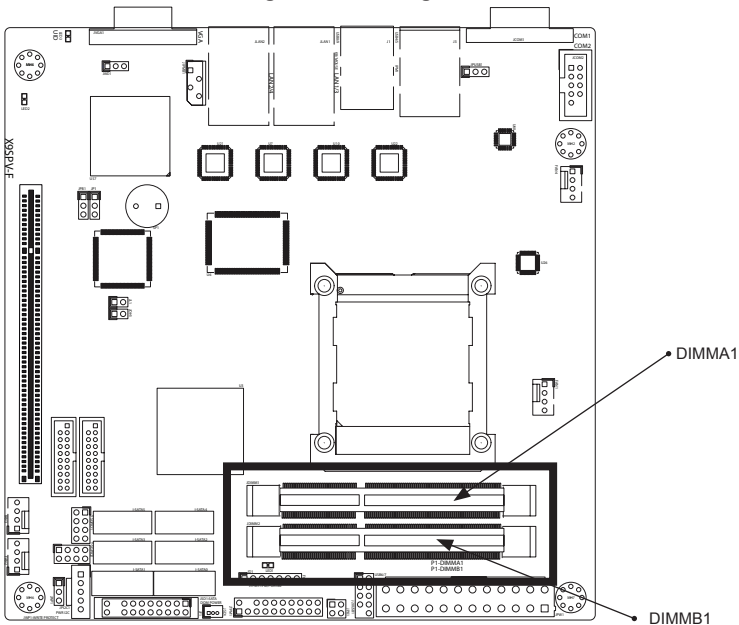

The SO DIMM Socket

1

Position the SO DIMM module's bottom key so it aligns with the receptive point on the slot. Take note of the module's side notches and the locking clips on the socket.

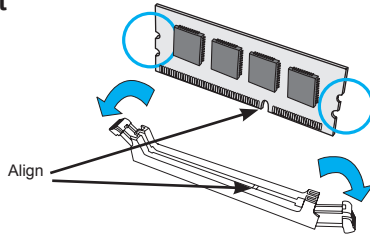
**2**

Insert the SO DIMM module straight down.

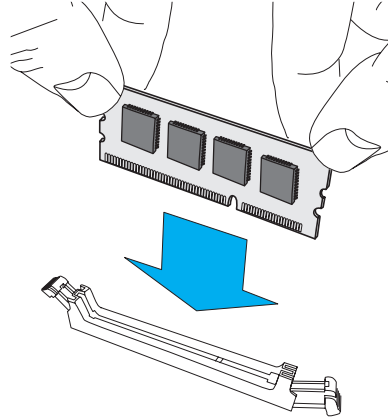
**3**

Press down until the module locks into place. The side clips will automatically secure the SO DIMM module, locking it into place.

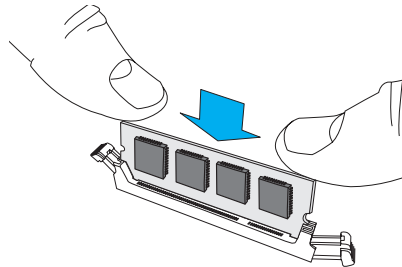
**4**

To Remove: Use your thumbs to gently push the side clips near both ends away from the module. This should release it from the slot. Pull the SO DIMM module upwards.

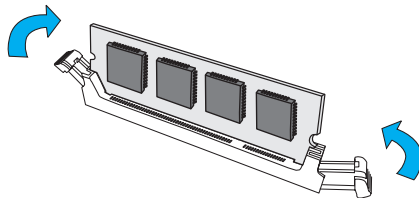

2-4 Connectors/I/O Ports

The I/O ports are color coded in conformance with the PC 99 specification. See the figure below for the colors and locations of the various I/O ports.

Back Panel Connectors and I/O Ports

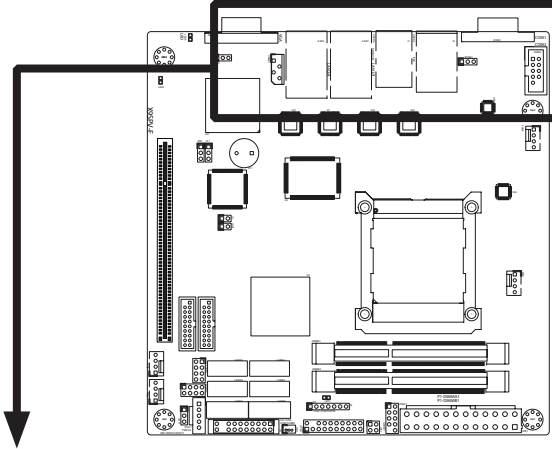

I/O Port Locations and Definitions

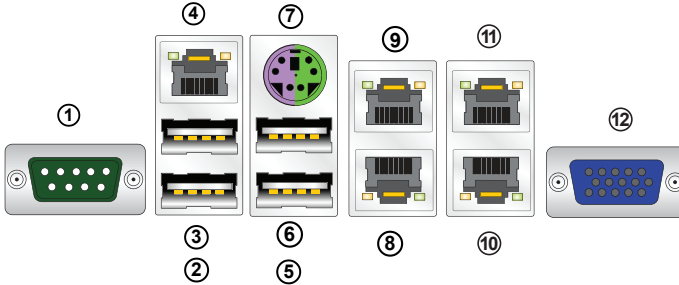

1. COM1	7. PS/2 Keyboard/Mouse
2. USB5	8. LAN2
3. USB4	9. LAN1
4. IPMI LAN	10. LAN4 (X9SPV-LN4F Only)
5. USB9	11. LAN3 (X9SPV-LN4F Only)
6. USB8	12. VGA

Back Panel Connectors

PS/2 KB/Mouse Port (KB/Mouse)

The PS/2 keyboard/mouse port is located above the Back Panel USB Ports 8/9 on the motherboard. See the table at right for pin definitions.



PS/2 KB/Mouse Pin Definitions (JF1)	
Pin#	Definition
1	KB Data
2	MS Data
3	Ground
4	Vcc
5	KB CLK
6	MS CLK



Note:

This motherboard offers three Keyboard/Mouse connection options as shown in the graphic below.

- 1. Connect a keyboard cable or a mouse cable to the PS/2 KB/Mouse port.
- 2. Plug in a Y cable that connects to a KB cable and a mouse cable on other end to USB Port 0.
- 3. Plug in a Y cable that connects to a KB cable and a mouse cable on other end to USB Port 1.

- ①  **Keyboard/Mouse**
(For a keyboard cable or Mouse cable)
- ②  **Back Panel USB (2.0)#8**
(For a Y cable that connects to a KB cable and a Mouse Cable)
- ③  **Back Panel USB (2.0)#9**
(For a Y cable that connects to a KB cable and a Mouse Cable)

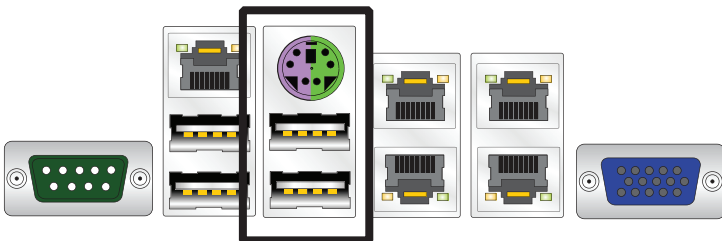

Back Panel Connectors

Universal Serial Bus (USB)

Four Universal Serial Bus ports (USB 4/5, 8/9) are located on the I/O backpanel. Additionally, one USB 2.0 header (USB 6/7) and two USB 3.0 headers (USB 0/1, 2/3) are also located on the motherboard to provide front chassis access. (Cables are not included). See the tables on the right for pin definitions.

Back Panel USB Type A USB 10 Pin Definitions			
Pin#	Definition	Pin#	Definition
1	+5V	5	+5V
2	USB_PN	6	USB_PN
3	USB_PP	7	USB_PP
4	Ground	8	Ground

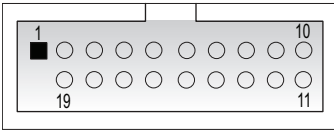

USB 3.0 Header

Front Panel USB 2.0 Pin Definitions			
Pin #	Definition	Pin #	Definition
1	+5V	6	+5V
2	USB_PN	7	USB_PN
3	USB_PP	8	USB_PP
4	Ground	9	Ground
5	NA	10	Key

Front Panel USB 3.0 Pin Definitions			
Pin#	Pin#	Signal Name	Description
1	19	VBUS	Power
2	18	IntA_SSRX-	SuperSpeed Rx-
3	17	IntA_SSRX+	SuperSpeed Rx+
4	16	GND	Ground
5	15	IntA_SSTX-	SuperSpeed Tx-
6	14	IntA_SSTX+	SuperSpeed Tx+
7	13	GND	Ground
8	12	IntA_D-	USB2 D-
9	11	IntA_D+	USB2 D+
10			Over Current Protection

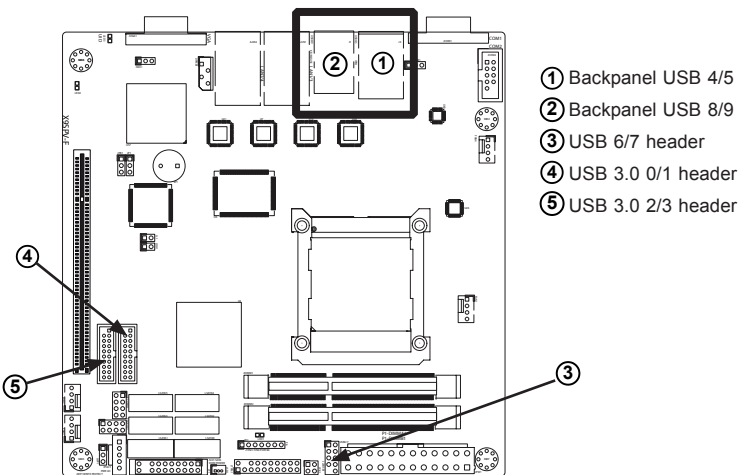

Serial Ports (COM1/COM2)

Two COM connections (COM1, COM2) are located on the motherboard. COM1 is located on the back I/O panel. A COM2 header is also located just behind the COM1 port to provide an additional onboard serial port. See the table on the right for pin definitions.

Serial Port COM2 Pin Definitions			
Pin #	Definition	Pin #	Definition
1	DCD	6	DSR
2	RXD	7	RTS
3	TXD	8	CTS
4	DTR	9	RI
5	Ground	10	N/A

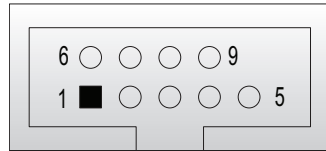

COM Port Pin Layout

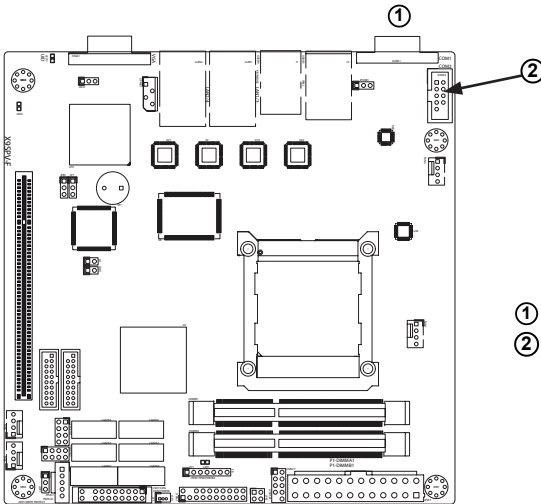

- ① (Backpanel) COM1
- ② COM2 header

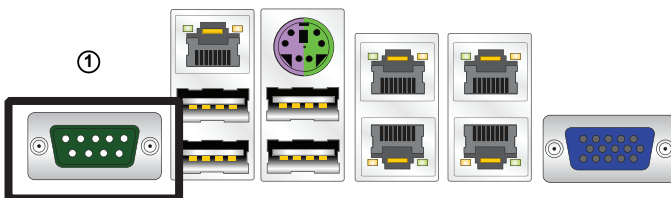

Back Panel Connectors

VGA Connector (VGA)

A VGA connector is located next to the LAN Ports on the I/O back panel. This connector is used to provide video display. Refer to the board layout below for the location.

VGA Port/Connector Pin Definitions			
Pin #	Definition	Pin #	Definition
1	Red Video	9	+5V DC
2	Green Video	10	Ground (Vsync, DDC)
3	Blue Video	11	Reserved
4	Reserved	12	I ² C Data
5	Ground	13	H Sync
6	Red Return	14	V Sync
7	Green Return	15	I ² C Clock
8	Blue Return		

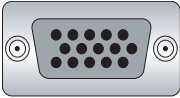

15-pin VGA Connector

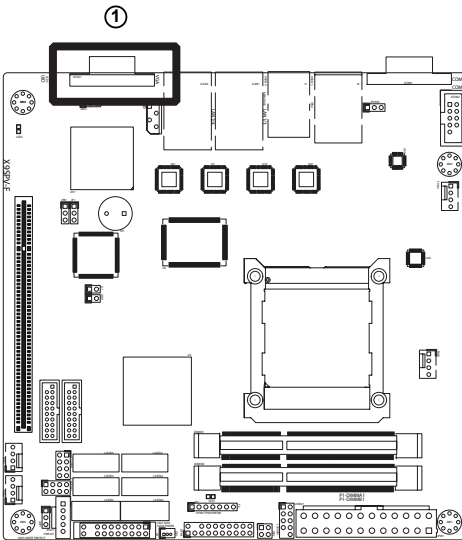

① VGA Port/Connector

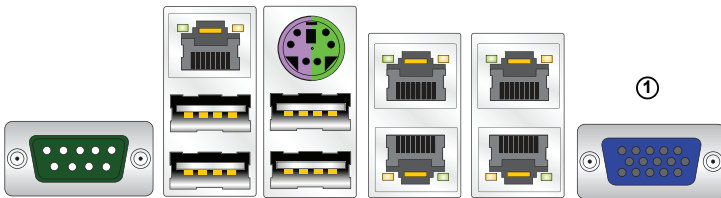

Back Panel Connectors

LAN Ports (LAN1~LAN4)

Two gigabit LAN ports are located on the I/O back panel (four on the X9SPV-LN4F). These ports accept RJ45 type cables. These are used to connect the motherboard to a network. On product models X9SPV-F and X9SPV-LN4F, an IPMI port is also provided for remote management through a TCP/IP network.

RJ45/LAN Pin Definitions			
Pin #	Definition	Pin #	Definition
1	TX_D1+	5	BI_D3-
2	TX_D1-	6	RX_D2-
3	RX_D2+	7	BI_D4+
4	BI_D3+	8	BI_D4-

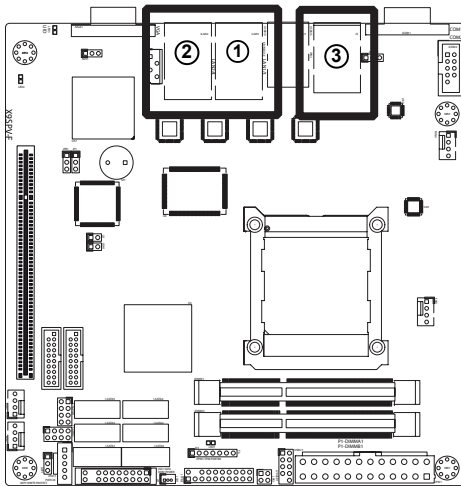

- ① LAN1/2
- ② LAN3/4
- ③ IPMI

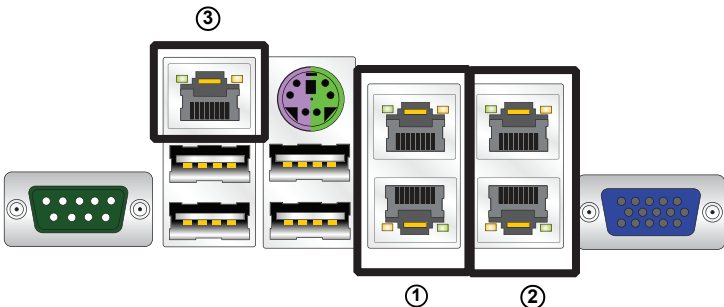

Back Panel Connectors

Front Control Panel

JF1 contains header pins for various buttons and indicators that are normally located on a control panel at the front of the chassis. These connectors are designed specifically for use with Supermicro server chassis. See the figure below for the descriptions of the various control panel buttons and LED indicators. Refer to the following section for descriptions and pin definitions.

JF1 Header Pins

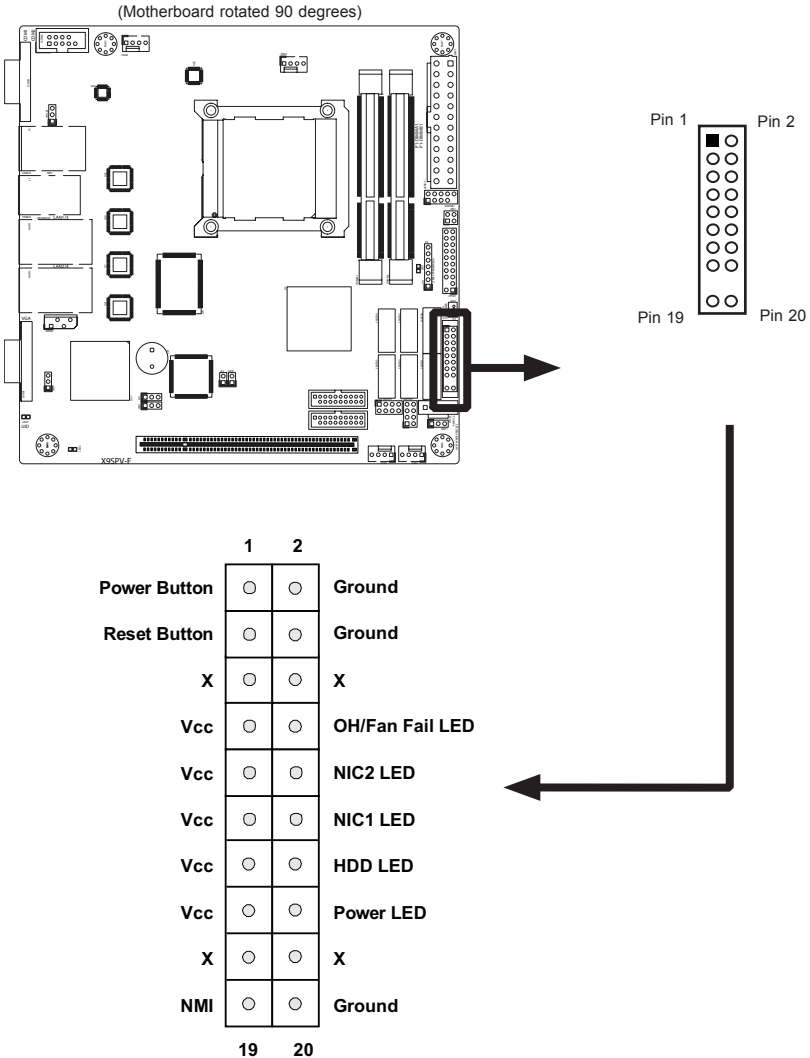

Front Control Panel Pin Definitions

Power LED

The Power LED connection is located on pins 15 and 16 of JF1. Refer to the table on the right for pin definitions.

Power LED Pin Definitions (JF1)	
Pin#	Definition
15	+3.3V
16	Ground

HDD LED

The HDD LED connection is located on pins 13 and 14 of JF1. Attach a hard drive LED cable here to display disk activity (for any hard drive activities on the system, including Serial ATA and IDE). See the table on the right for pin definitions.

HDD LED Pin Definitions (JF1)	
Pin#	Definition
13	+3.3V
14	HD Active

NIC1/NIC2 LED Indicators

The NIC (Network Interface Controller or Ethernet Controller) LED connection for LAN port 1 is located on pins 11 and 12 of JF1, and the LED connection for LAN Port 2 is on Pins 9 and 10. Attach the NIC LED cables to display network activity. Refer to the table on the right for pin definitions.

NIC 1/2 LED Pin Definitions (JF1)	
Pin#	Definition
11/9	Vcc
12/10	Ground

- A** POWER LED
- B** HDD LED
- C** NIC1
- D** NIC2

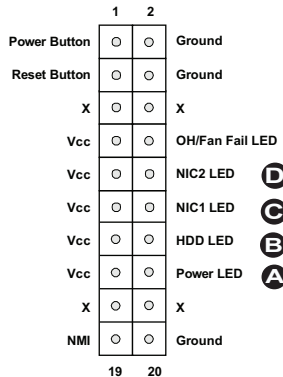

JF1 Header Pins

Overheat (OH)/Fan Fail LED

Connect an LED Cable to the OH/Fan Fail connection on pins 7 and 8 of JF1 to provide advanced warnings of chassis overheat or fan failure. Refer to the table on the right for pin definitions.

OH/Fan Fail Indicator Status	
State	Definition
Off	Normal
On	Overheat
Flashing	Fan Fail

Power Fail LED

The Power Fail LED connection is located on pins 5 and 6 of JF1. Refer to the table on the right for pin definitions.

Power Fail LED Pin Definitions (JF1)	
Pin#	Definition
5	Vcc
6	Ground

NMI Button

The non-maskable interrupt button header is located on pins 19 and 20 of JF1. Refer to the table on the right for pin definitions.

NMI Button Pin Definitions (JF1)	
Pin#	Definition
1	Signal
2	Ground

- A** OH/Fan Fail LED
- B** Power Fail LED
- C** NMI Button

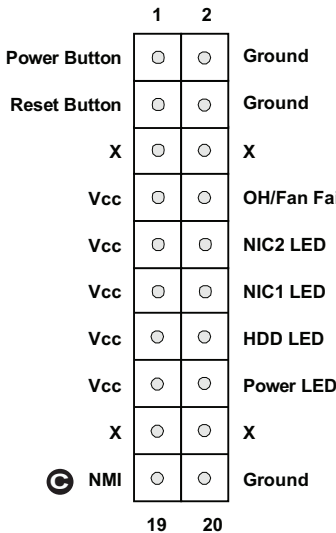

JF1 Header Pins

Reset Button

The Reset Button connection is located on pins 3 and 4 of JF1. Attach it to a hardware reset switch on the computer case. Refer to the table on the right for pin definitions.

Reset Button Pin Definitions (JF1)	
Pin#	Definition
3	Reset
4	Ground

Power Button

The Power Button connection is located on pins 1 and 2 of JF1. Momentarily contacting both pins will power on/off the system. To turn off the power when set to suspend mode, press the button for at least 4 seconds. Refer to the table on the right for pin definitions.

Power Button Pin Definitions (JF1)	
Pin#	Definition
1	Signal
2	Ground

- A** Reset Button
- B** PWR Button

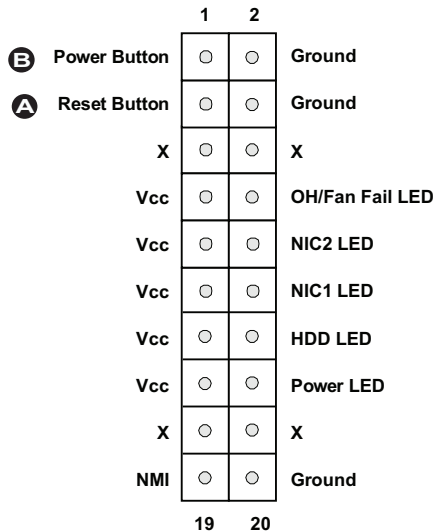

JF1 Header Pins

2-5 Connecting Cables

This section provides brief descriptions and pin-out definitions for onboard power connectors. Be sure to use the correct cable for each header or connector.

ATX Power Connector (JPW1)

The 24-pin power connector is used to provide power to the motherboard. This connector meets the SSI EPS 12V specification. See the tables on the right for pin definitions.

ATX Power 24-pin Connector Pin Definitions (JPW1)			
Pin#	Definition	Pin #	Definition
13	+3.3V	1	+3.3V
14	-12V	2	+3.3V
15	COM	3	COM
16	PS_ON	4	+5V
17	COM	5	COM
18	COM	6	+5V
19	COM	7	COM
20	Res (NC)	8	PWR_OK
21	+5V	9	5VSB
22	+5V	10	+12V
23	+5V	11	+12V
24	COM	12	+3.3V

(Required)

A 24-pin PWR

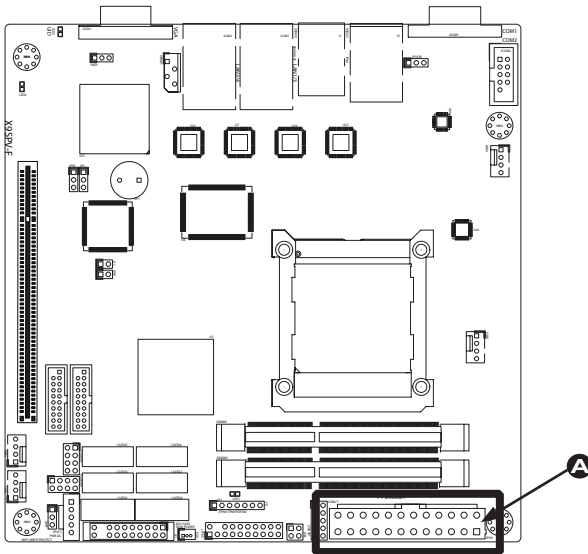

Fan Headers

The X9SPV Motherboard Series has three fan headers (Fan1~Fan3). These fans are 4-pin fan headers. Although Pins 1~3 of the fan headers are backward compatible with the traditional 3-pin fans, please 4-pin fans on the motherboard to enable the motherboard to control fan speed through the BIOS. Refer to the table on the right for pin definitions.

Fan Header Pin Definitions	
Pin#	Definition
1	Ground
2	+12V
3	Tachometer
4	PWM_Control

 **Note:** The speeds of 4-pin (PWM) fans are controlled by Thermal Management via BIOS Hardware Monitoring in the Advanced Setting. (The default setting is **Disabled**.)

- A** Fan1
- B** Fan2
- C** Fan3
- D** Fan4

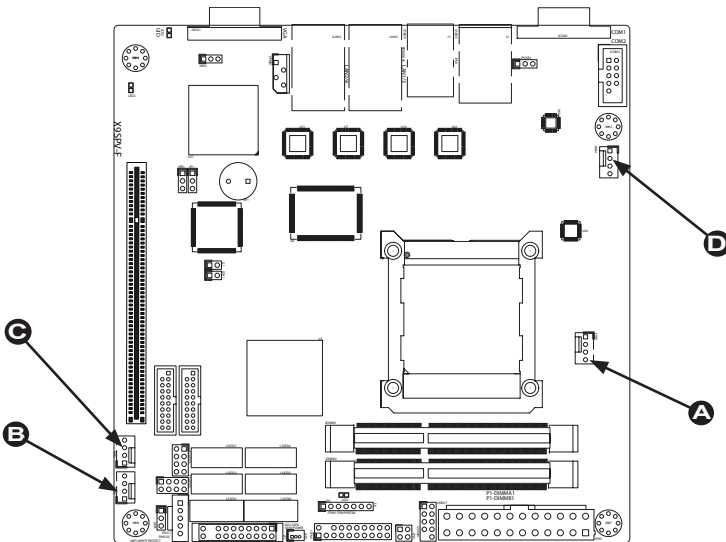

Chassis Intrusion (JL1)

A Chassis Intrusion header is located at JL1 on the motherboard. Attach the appropriate cable from the chassis to inform you of a chassis intrusion when the chassis is opened.

Chassis Intrusion Pin Definitions (JL1)	
Pin#	Definition
1	Intrusion Input
2	Ground

TPM Header (JTPM1)

This header is used to connect a Trusted Platform Module (TPM), available from a third-party vendor. A TPM is a security device that allows encryption and authentication of hard drives. It enables the motherboard to deny access if the TPM associated with the hard drive is not installed in the system. See the table on the right for pin definitions.

Trusted Platform Module Header Pin Definitions			
Pin #	Definition	Pin #	Definition
1	LCLK	2	GND
3	LFRAME	4	No Pin
5	LRESET	6	VCC5
7	LAD3	8	LAD2
9	VCC3	10	LAD1
11	LAD0	12	GND
13	RSV0	14	RSV1
15	SB3V	16	SERIRQ
17	GND	18	CLKRUN
19	LPCPD	20	RSV2

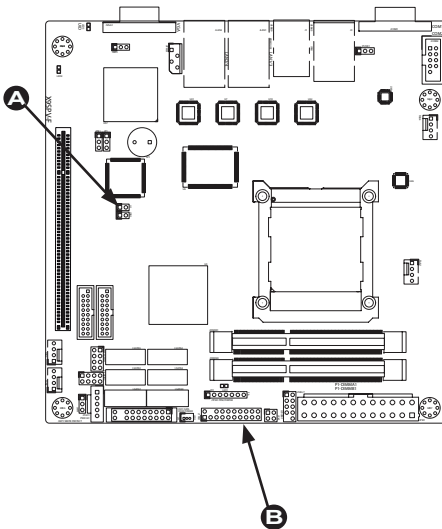

- A** Chassis Intrusion
- B** TPM Header

SATA DOM Power (JSD1)

The SATA DOM Power on JSD1 is used to supply power to SATA Disk-on-Module (DOM) solid-state storage devices.

SATA DOM Power Pin Definitions	
Pin#	Definition
1	+5V
2	Ground
3	Ground

Power SMB I²C Connector (JPI2C1)

Power System Management Bus (I²C) connector enables monitoring the status of the power supply, fan and system temperature. See the table on the right for pin definitions.

PWR Supply I ² C Pin Definitions	
Pin#	Definition
1	Clock
2	Data
3	PWR Fail
4	Ground
5	+3.3V

System Management Bus (JIPMB1)

A System Management Bus header for the IPMI slot is located at IPMB. Connect the appropriate cable here to use the IPMB I²C connection on your system.

System Management Bus	
Pin#	Definition
1	Clock
2	Ground
3	Data
4	No Connection

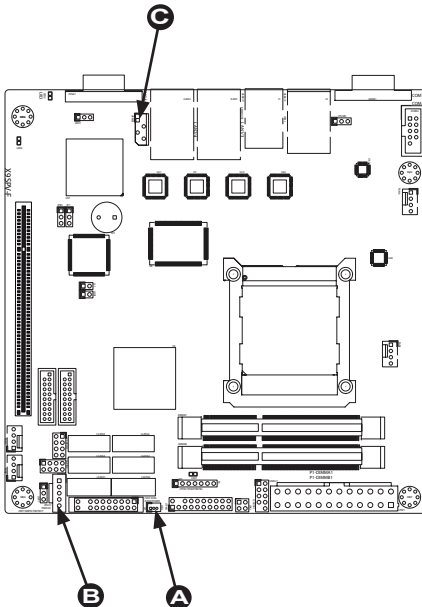

- A** SATA DOM Power
- B** SMB I2C Connector
- C** IPMI SMB

T-SGPIO Headers (T-SGPIO1/2)

The T-SGPIO1 and T-SGPIO2 (Serial-Link General Purpose Input/Output) headers are located near the SATA connectors on the motherboard. These headers are used to communicate with the enclosure management chip in the system. See the table on the right for pin definitions. Refer to the board layout below for the locations of the headers.

Serial_Link-SGPIO Pin Definitions			
Pin#	Definition	Pin	Definition
1	NC	2	NC
3	Ground	4	DATA Out
5	Load	6	Ground
7	Clock	8	NC

Overheat/Fan Fail LED (JOH1)

The JOH1 header is used to connect an LED to provide warnings of chassis overheat. This LED will also blink to indicate a fan failure. Refer to the table on right for pin definitions.

Overheat LED Pin Definitions	
Pin#	Definition
1	5vDC
2	OH Active

OH/Fan Fail LED Status Message	
State	Message
Solid	Overheat
Blinking	Fan Fail

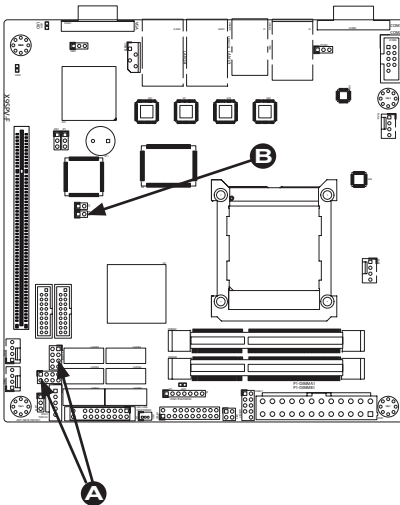

- A** T-SGPIO Headers
- B** OH/Fan Fail LED

Power LED/Speaker (JD1)

On the JD1 header, pins 1~3 are used for a power LED and pins 4~7 are used for an external speaker. If you wish to use the onboard speaker, you should close pins 6-7 with a jumper. See the table on the right for speaker pin definitions.

Speaker Connector Pin Definitions	
Pin Setting	Definition
Pins 6-7	Internal Speaker
Pins 4-7	External Speaker

Internal Speaker/Buzzer (SP1)

The Internal Speaker on SP1 can be used to provide audible indications for various beep codes. See the table on the right for pin definitions. Refer to the layout below for the locations of the Internal Buzzer (SP1).

Internal Buzzer Pin Definition		
Pin#	Definitions	
Pin 1	Pos. (+)	Beep In
Pin 2	Neg. (-)	Alarm Speaker

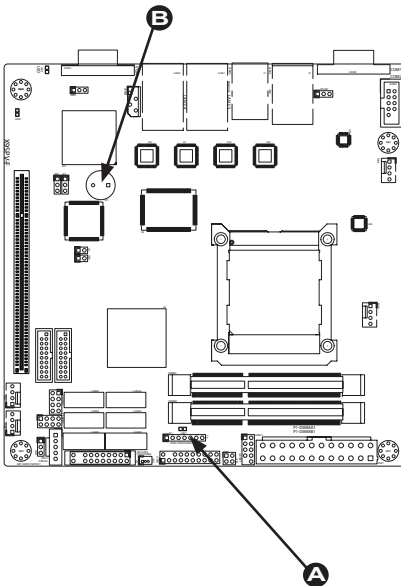
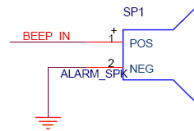

- A** PWR LED/SPKR
- B** Internal Speaker/Buzzer

2-6 Jumper Settings

Explanation of Jumpers

To modify the operation of the motherboard, jumpers can be used to choose between optional settings. Jumpers create shorts between two pins to change the function of the connector. Pin 1 is identified with a square solder pad on the printed circuit board.



Note: On two pin jumpers, "Closed" means the jumper is on and "Open" means the jumper is off the pins.

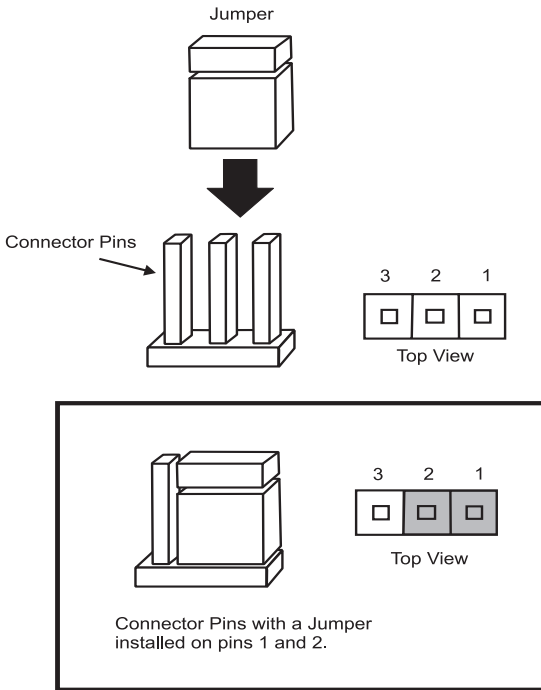

BMC Enable/Disable (JPB1)

JPB1 is used to enable or disable the BMC (Baseboard Management Control) chip and the onboard IPMI connection. This jumper is used together with the IPMI settings in the BIOS. See the table on the right for jumper settings. Supported on both the X9SPV-F and X9SPV-LN4F.

BMC IPMI Enable/Disable Jumper Settings

Settings	Definition
Pins 1-2	Enabled (Default)
Pins 2-3	Disabled

BIOS Write Protect (JWP1)

The BIOS Write-Protect jumper (JWP1) is used to protect the BIOS firmware from accidentally being erased. Close pins 2-3 before reprogramming the firmware. Otherwise, we recommend that it is enabled (pins 1-2) during normal operation.

BMC IPMI Enable/Disable Jumper Settings

Settings	Definition
Pins 1-2	Enabled (Default)
Pins 2-3	Disabled

- A** BMC Enable/Disable
- B** BIOS Write-Protect

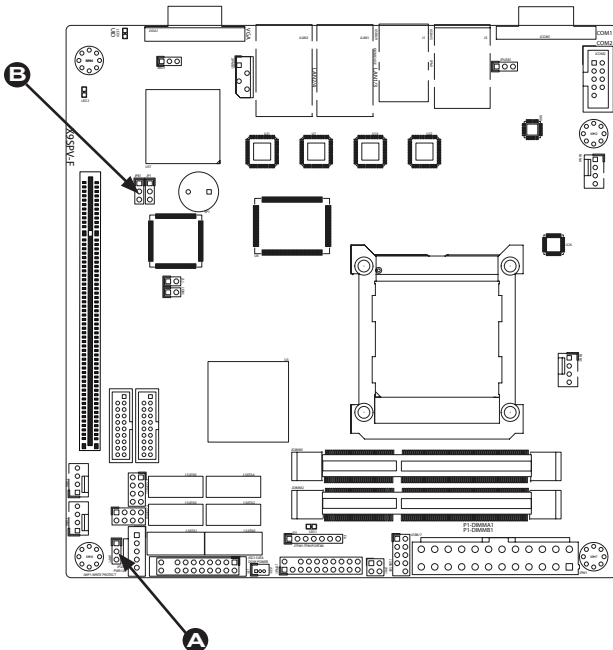

CMOS Clear (JBT1)

JBT1 is used to clear CMOS. Instead of pins, this "jumper" consists of contact pads to prevent accidental clearing of CMOS. To clear CMOS, use a metal object such as a small screwdriver to touch both pads at the same time to short the connection. Always remove the AC power cord from the system before clearing CMOS.



Metal contact pads

 **Important:** For an ATX power supply, you must completely shut down the system, remove the AC power cord and then short JBT1 to clear CMOS.

 CMOS Clear

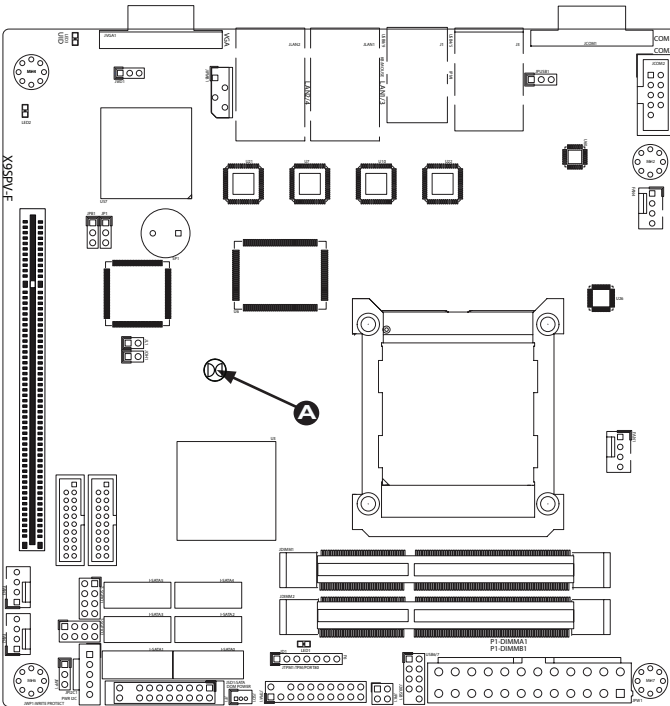

USB Wake-Up (JPUSB1)

Use the JPUSB1 jumper to enable system "wake-up" via a USB device. This jumper allows you to "wake-up" the system by pressing a key on the USB keyboard or by clicking the USB mouse of your system. The JPUSB1 jumper is used together with the USB Wake-Up function in the BIOS. Enable both the jumper and the BIOS setting to activate this function. See the table on the right for jumper settings and jumper connections.

USB Wake-Up Jumper Settings	
Jumper Setting	Definition
Pins 1-2	Enabled
Pins 2-3	Disabled (Default)



Note: The default jumper setting is "Disabled". When the "USB Wake-Up" function is enabled, it will be active on all USB ports.

A USB Wake-up

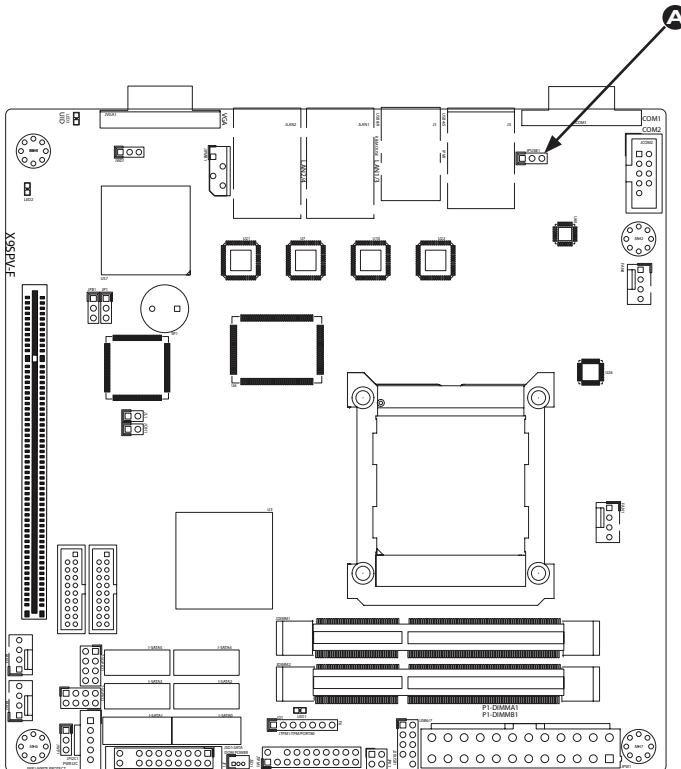

Watch Dog Reset (JWD1)

Watch Dog (JWD1) is a system monitor that can reboot the system when a software application hangs. Close pins 1~2 to reset the system if an application hangs. Close pins 2~3 to generate a non-maskable interrupt signal for the application that hangs. See the table on the right for jumper settings. Watch Dog must also be enabled in the BIOS.

Watch Dog Jumper Settings	
Jumper Setting	Definition
Pins 1-2	Reset (default)
Pins 2-3	NMI
Open	Disabled

A Watch Dog Reset

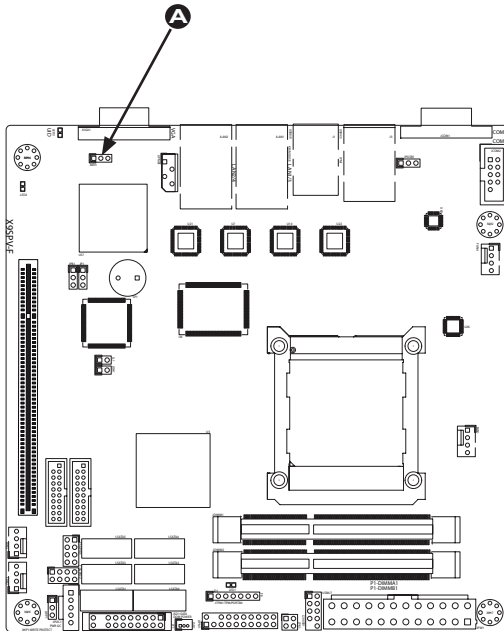

2-7 Onboard Indicators

LAN Port LEDs

Two LAN ports are located on the I/O Backpanel. Each Ethernet LAN port has two LEDs. The yellow Activity LED (right, see below) indicates activity, while the Link/Speed LED (left) may be green, amber or off to indicate the speed of the connection. See the tables at right for more information.

GLAN Link/Speed LED Indicator	
LED Color	Definition
Off	No Connection or 10 Mbps
Green (On)	100 Mbps
Amber (On)	1 Gbps

GLAN Activity LED Indicator	
Color	Definition
Yellow (Flashing)	ConnectionActive

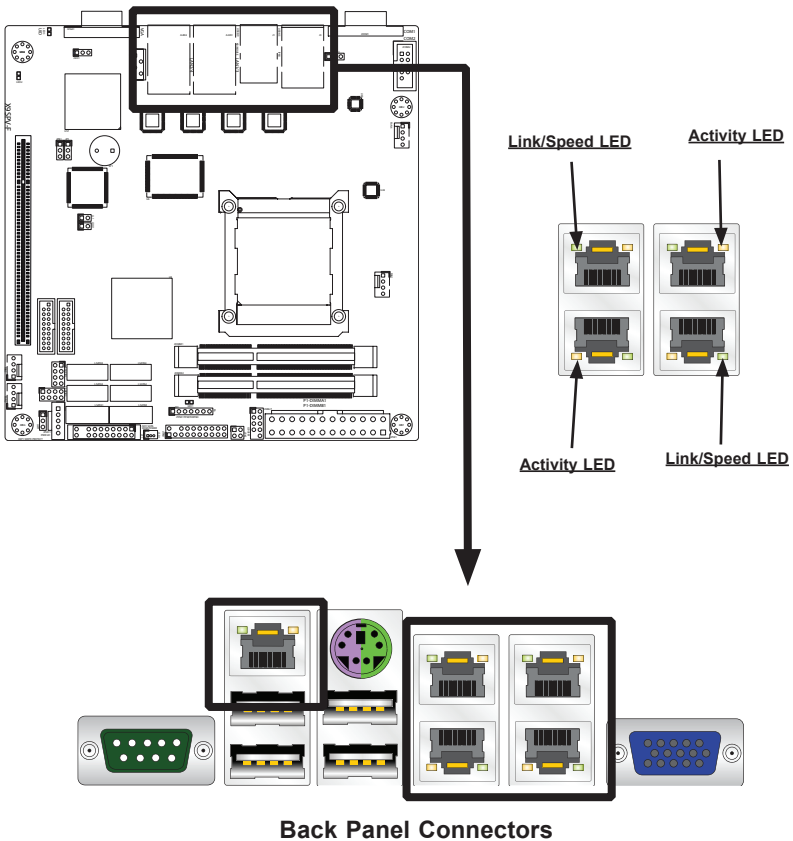

Rear View
rear side of

Standby Power LED (LED1)

An Onboard Power LED is located at LED1 on the motherboard. When LED1 is on, the AC power cable is connected and the power supply hard switch is on. The system may be on standby or running.

Onboard PWR LED (LED1) LED Status	
Status	Definition
Off	System Off (Soft Switch)
On	Power is Detected

IPMI Heartbeat LED (LED2)

An IPMI Heartbeat LED is located at LED2. When LED2 blinks, it means that IPMI is enabled and functioning properly. For the X9SPV-F and X9SPV-LN4F only.

IPMI Heartbeat LED (LED2) LED Settings	
Status	Definition
Green: Blinking	IPMI is ready for use
Off	IPMI Disabled

Overheat / Fan Fail (LED3)

LED3 is located next to the VGA port. This indicator alerts of either a Fan Failure, or System Overheat.

OH/Fan Fail LED Indicator (LED3) LED Settings	
Status	Definition
Yellow: Blinking with continuous beep	Fan Failure
Yellow: Solid with continuous beep	System Overheat
Off	Normal

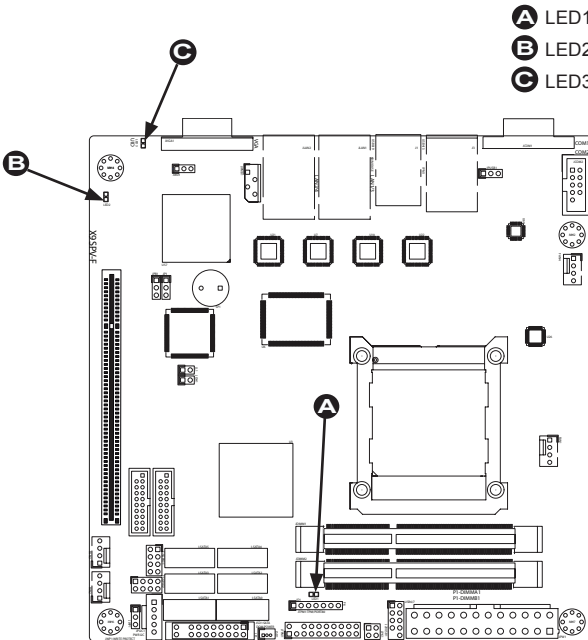

2-8 Serial ATA and HDD Connections

Note the following conditions when connecting the Serial ATA and hard disk drive cables:

- Be sure to use the correct cable for each connector. Refer to Page 1-1 for cables that came with your shipment.

SATA Connections (SATA1~SATA6)

Two Serial ATA (SATA) 3.0 connectors (I-SATA 0/1) are located on the motherboard. In addition, four SATA 2.0 (I-SATA 2~5) connectors are also located on the board. The SATA 3.0 ports support RAID 0, 1 while the SATA 2.0 ports support RAID 0, 1, 5 & 10. These Serial Link connections provide faster data transmission than legacy Parallel ATA. See the table below for pin definitions.

SATA Connector Types		
Port#	Connection Type	Connector Color
SATA 0/1,	SATA 3.0	White
SATA 2~5	SATA 2.0	Black

SATA 2.0/3.0 Connectors Pin Definitions	
Pin#	Signal
1	Ground
2	SATA_TXP
3	SATA_TXN
4	Ground
5	SATA_RXN
6	SATA_RXP
7	Ground

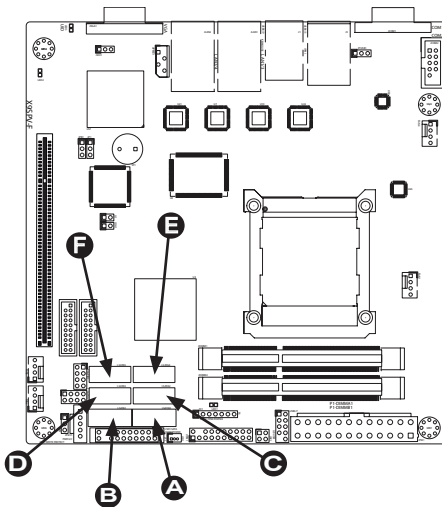

- A** I-SATA0 (3.0)
- B** I-SATA1 (3.0)
- C** I-SATA2
- D** I-SATA3
- E** I-SATA4
- F** I-SATA5

Notes

Chapter 3

Troubleshooting

3-1 Troubleshooting Procedures

Use the following procedures to troubleshoot your system. If you have followed all of the procedures below and still need assistance, refer to the 'Technical Support Procedures' and/or 'Returning Merchandise for Service' section(s) in this chapter. Always disconnect the AC power cord before adding, changing or installing any hardware components.

Before Power On

1. Be sure to unplug the power cable before installing or removing the components.)
2. Make sure that there are no short circuits between the motherboard and chassis.
3. Disconnect all ribbon/wire cables from the motherboard, including those for the keyboard and mouse. Also, be sure to remove all add-on cards.
4. Connect the chassis speaker and the power LED to the motherboard. Check all jumper settings as well.

No Power

1. Make sure that there are no short circuits between the motherboard and chassis.
2. Make sure that all jumpers are set to their default positions.
3. Check if the 115V/230V switch on the power supply is properly set.
4. Turn the power switch on and off to test the system.
5. The battery on your motherboard may be old. Check to make sure that it still supplies ~3VDC. If it does not, replace it with a new one.

No Video

1. If the power is on, but you have no video--in this case, you will need to remove all the add-on cards and cables first.

2. Use the speaker to determine if any beep codes exist. (Refer to Appendix A for details on beep codes.)
3. Remove all memory modules and turn on the system. (If the alarm is on, check the specs of memory modules, reset the memory or try a different one.)

Memory Errors

1. Make sure that the ECC SO-DIMM modules are properly installed and fully seated in the slots.
2. Please check Section 2-3 and make sure that you are using the correct memory. Also, it is recommended that you use the memory modules of the same type and speed for all DIMMs in the system.
3. Check for bad DIMM modules or slots by swapping modules between slots to see if you can locate the faulty modules.
4. Check the power supply voltage 115V/230V switch.

If You Lose the System's Setup Configuration

1. Please be sure to use a high quality power supply. A poor quality power supply may cause the system to lose the CMOS setup information. Refer to Section 1-5 for details on recommended power supplies.
2. The battery on your motherboard may be old. Check to verify that it still supplies ~3VDC. If it does not, replace it with a new one.
3. If the above steps do not fix the Setup Configuration problem, contact your vendor for repairs.

3-2 Technical Support Procedures

Before contacting Technical Support, please make sure that you have followed all the steps listed below. Also, Note that as a motherboard manufacturer, Supermicro does not sell directly to end users, so it is best to first check with your distributor or reseller for troubleshooting services. They should know of any possible problem(s) with the specific system configuration that was sold to you.

1. Please go through the 'Troubleshooting Procedures' and 'Frequently Asked Question' (FAQ) sections in this chapter or see the FAQs on our website (<http://www.supermicro.com/support/faqs/>) before contacting Technical Support.
2. BIOS upgrades can be downloaded from our website at (<http://www.supermicro.com/support/bios/>).



Note: Not all BIOS can be flashed. Some cannot be flashed; it depends on the modifications to the boot block code.

3. If you've followed the instructions above to troubleshoot your system, and still cannot resolve the problem, then contact Supermicro's technical support and provide them with the following information:

- Motherboard model and PCB revision number
- BIOS release date/version (this can be seen on the initial display when your system first boots up)
- System configuration (OS version, peripheral devices, power supply type, etc)

An example of a Technical Support form is on our website at <http://www.supermicro.com/support/contact.cfm>.

4. Distributors: For immediate assistance, please have your account number ready when placing a call to our technical support department. We can be reached by e-mail at support@supermicro.com, by phone at: (408) 503-8000, option 2, or by fax at (408)503-8019.

3-3 Frequently Asked Questions

Question: What type of memory does my motherboard support?

Answer:

The X9SPV Motherboard Series supports up to 16GB of ECC DDR3 1066/1333 MHz, two-way interleaved or non-interleaved SO-DIMM memory. See Section 2-4 for details on installing memory.

Question: Why does Microsoft Windows show less memory than what is physically installed?

Answer: Microsoft implemented a design change in Windows XP with Service Pack 2 (SP2) and Windows Vista. This change is specific to the Physical Address Extension (PAE) mode behavior which improves driver compatibility. For more information, please read the following article at Microsoft's Knowledge Base website at: <http://support.microsoft.com/kb/888137>.

Question: How do I update my BIOS?

Answer: It is recommended that you **do not** upgrade your BIOS if you are not experiencing any problems with your system. Updated BIOS files are located on our web site at <http://www.supermicro.com/support/bios/>. Please check our

BIOS warning message and the information on how to update your BIOS on our web site. Select your motherboard model and download the BIOS (.rom) file to your computer. Also, check the current BIOS revision and make sure that it is newer than your BIOS before downloading. You may choose the zip file or the .exe file. If you choose the zipped BIOS file, please unzip the BIOS file onto a bootable device or a USB pen/thumb drive. To flash the BIOS, run the batch file named "ami.bat" with the new BIOS ROM file from your bootable device or USB pen/thumb drive. Use the following format:

```
F:\> ami.bat BIOS-ROM-filename.xxx <Enter>
```



Notes: Always use the file named "ami.bat" to update the BIOS and insert a space between "ami.bat" and the filename. The BIOS-ROM-filename will bear the motherboard name (i.e., X9SCV) and build date as the extension. For example, "X9SCV0.526".

When completed, your system will automatically reboot. If you choose the .exe file, please run the .exe file under Windows to create the BIOS flash floppy disk. Insert the floppy disk into the system you wish to flash the BIOS. Then, boot the system to the floppy disk. The BIOS utility will automatically flash the BIOS without any prompts. Please note that this process may take a few minutes to complete. Do not be concerned if the screen is paused for a few minutes.



Warning: Do not shut down or reset the system while updating the BIOS to prevent possible system boot failure!

When the BIOS flashing screen is completed, the system will reboot and will show "Press F1 or F2". At this point, you will need to load the BIOS defaults. Press <F1> to go to the BIOS setup screen, and press <F9> to load the default settings. Next, press <F10> to save and exit. The system will then reboot.



Note: The SPI BIOS chip installed on this motherboard is not removable. To repair or replace a damaged BIOS chip, please send your motherboard to RMA at Supermicro for service.

If your BIOS crashes and your motherboard will no longer boot, please read Appendix C - UEFI BIOS Recovery Instructions for instructions.

3-4 Returning Merchandise for Service

A receipt or copy of your invoice marked with the date of purchase is required before any warranty service will be rendered. You can obtain service by calling your vendor for a Returned Merchandise Authorization (RMA) number. When returning to the manufacturer, the RMA number should be prominently displayed on the outside of the shipping carton, and mailed prepaid or hand-carried. Shipping and handling charges will be applied for all orders that must be mailed when service is complete.

This warranty only covers normal consumer use and does not cover damages incurred in shipping or from failure due to the alteration, misuse, abuse or improper maintenance of products.

During the warranty period, contact your distributor first for any product problems.

Notes

Chapter 4

BIOS

4-1 Introduction

This chapter describes the AMI BIOS Setup Utility for the X9SPV-F/LN4F Motherboard. The AMI ROM BIOS is stored in a Flash EEPROM and can be easily updated. This chapter describes the basic navigation of the AMI BIOS Setup Utility setup screens.



Note: For instructions on BIOS recovery, please refer to the instruction guide posted at <http://www.supermicro.com/support/manuals/>.

Starting BIOS Setup Utility

To enter the AMI BIOS Setup Utility screens, press the <Delete> key while the system is booting up.



Note: In most cases, the <Delete> key is used to invoke the AMI BIOS setup screen. There are a few cases when other keys are used, such as <F1>, <F2>, etc.

Each main BIOS menu option is described in this manual. The Main BIOS setup menu screen has two main frames. The left frame displays all the options that can be configured. Grayed-out options cannot be configured. Options in blue can be configured by the user. The right frame displays the key legend. Above the key legend is an area reserved for a text message. When an option is selected in the left frame, it is highlighted in white. Often a text message will accompany it. (**Note:** the AMI BIOS has default text messages built in. Supermicro retains the option to include, omit, or change any of these text messages.)

The AMI BIOS Setup Utility uses a key-based navigation system called "hot keys". Most of the AMI BIOS setup utility "hot keys" can be used at any time during the setup navigation process. These keys include <F1>, <F10>, <Enter>, <ESC>, arrow keys, etc.



Note: Options printed in **Bold** are default settings.

How To Change the Configuration Data

The configuration data that determines the system parameters may be changed by entering the AMI BIOS Setup utility. This Setup utility can be accessed by pressing at the appropriate time during system boot.

How to Start the Setup Utility

Normally, the only visible Power-On Self-Test (POST) routine is the memory test. As the memory is being tested, press the <Delete> key to enter the main menu of the AMI BIOS Setup Utility. From the main menu, you can access the other setup screens. An AMI BIOS identification string is displayed at the left bottom corner of the screen, below the copyright message.



Warning: Do not upgrade the BIOS unless your system has a BIOS-related issue. Flashing the wrong BIOS can cause irreparable damage to the system. In no event shall Supermicro be liable for direct, indirect, special, incidental, or consequential damages arising from a BIOS update. If you have to update the BIOS, do not shut down or reset the system while the BIOS is updating. This is to avoid possible boot failure.

4-2 Main Setup

When you first enter the AMI BIOS Setup Utility, you will enter the Main setup screen. You can always return to the Main setup screen by selecting the Main tab on the top of the screen. The Main BIOS Setup screen is shown below.

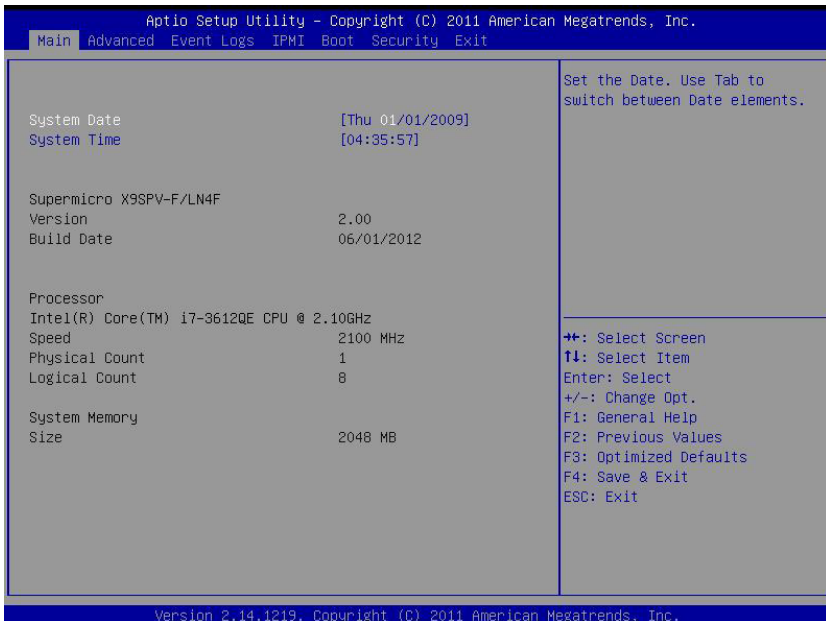

System Overview: The following BIOS information will be displayed:

System Time/System Date

Use this option to change the system time and date. Highlight *System Time* or *System Date* using the arrow keys. Enter new values through the keyboard. Press the <Tab> key or the arrow keys to move between fields. The date must be entered in Day MM/DD/YY format. The time is entered in HH:MM:SS format. (**Note:** The time is in the 24-hour format. For example, 5:30 P.M. appears as 17:30:00.)

Supermicro X9SPV-F/LN4F

Version: This item displays the version of the BIOS used in the system.

Build Date: This item displays the day this version of BIOS was built.

Processor

This displays the processor type, speed, physical count, and logical count.

System Memory

This displays the size of memory available in the system.

4-3 Advanced Setup Configurations

Use the arrow keys to select Boot Setup and hit <Enter> to access the submenu items:

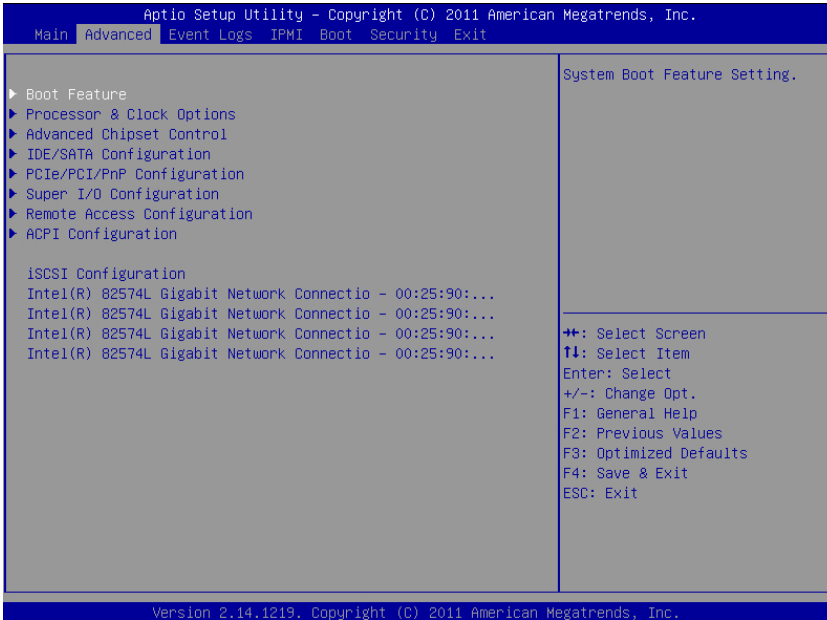

►BOOT Feature

Quiet Boot

This option allows the bootup screen options to be modified between POST messages or the OEM logo. Select Disabled to display the POST messages. Select Enabled to display the OEM logo instead of the normal POST messages. The options are **Enabled** and Disabled.

Option ROM Display Messages

This sets the display mode for Option ROM. The options are **Force BIOS** and Keep Current.

Bootup Num-Lock

This feature selects the Power-on state for Numlock key. The options are Off and **On**.

Wait For 'F1' If Error

This forces the system to wait until the 'F1' key is pressed if an error occurs. The options are Disabled and **Enabled**.

INT19 Trap Response

The Interrupt 19 (INT19) feature determines how the BIOS will react to INT19 trapping by Option ROM. If set to Immediate, BIOS will execute the trap right away. If set to Postponed, BIOS will execute the trap during legacy boot. The options are **Immediate** and Postponed

Watch Dog Function

If enabled, the Watch Dog Timer will allow the system to reboot when it is inactive for more than 5 minutes. The options are Enabled and **Disabled**.

Power Button Function

This feature controls how the system shuts down when the power button is pressed. Select 4-Seconds Override to force the user to press and hold the Power Button for 4 seconds before the system turns off. Select Instant Off if you want the system to instantly power off when the Power Button is pressed. The options are 4 Seconds Override and **Instant Off**.

Restore on AC Power Loss

Use this feature to set the power state after a power outage. Select Stay-Off for the system power to remain off after a power loss. Select Power-On for the system power to be turned on after a power loss. Select Last State to allow the system to resume its last state before a power loss. The options are Power-On, Stay-Off and **Last State**.

►Processor and Clock Options



Warning: Take Caution when changing the Advanced settings. An incorrect value, a very high DRAM frequency or incorrect DRAM timing may cause system to become unstable. When this occurs, revert to the default setting.

The top section is for informational purposes only and displays CPU information including type, speed, number of cores, etc.

Hyper Threading

Set to Enabled to use the processor's Hyper Threading Technology feature. The options are **Enabled** and Disabled.

Active Processor Cores

Set to Enabled to use a processor's Second Core and beyond. (Please refer to Intel's web site for more information.) The options are **All**, 1, 2, and 3.

Limit CPUID Maximum

This feature allows the user to set the maximum CPU ID value. Enable this function to boot the legacy operating systems that cannot support processors with extended CPUID functions. The options are Enabled and **Disabled** (for the Windows OS.).

Execute-Disable Bit (Available when supported by the OS and the CPU)

Set to Enabled to enable the Execute Disable Bit which will allow the processor to designate areas in the system memory where an application code can execute and where it cannot, thus preventing a worm or a virus from flooding illegal codes to overwhelm the processor or damage the system during an attack. The default is **Enabled**. (Refer to Intel and Microsoft Web Sites for more information.)

Intel[®] Virtualization Technology (Available when supported by the CPU)

Select Enabled to use the feature of Virtualization Technology to allow one platform to run multiple operating systems and applications in independent partitions, creating multiple "virtual" systems in one physical computer. The options are Enabled and **Disabled**.



Note: If there is any change to this setting, you will need to power off and restart the system for the change to take effect. Please refer to Intel's web site for detailed information.

Hardware Prefetcher (Available when supported by the CPU)

If set to Enabled, the hardware pre fetcher will pre fetch streams of data and instructions from the main memory to the L2 cache in the forward or backward manner to improve CPU performance. The options are Disabled and **Enabled**.

Adjacent Cache Line Prefetch (Available when supported by the CPU)

The CPU fetches the cache line for 64 bytes if this option is set to Disabled. The CPU fetches both cache lines for 128 bytes as comprised if **Enabled**.

Clock Spread Spectrum

Select Enable to use the feature of Clock Spectrum, which will allow the BIOS to monitor and attempt to reduce the level of Electromagnetic Interference caused by the components whenever needed. Select Disabled to enhance system stability. The options are **Disabled** and Enabled.

► CPU PPM Configuration

Power Technology

This feature determines what power-saving scheme the motherboard uses. The options are Disabled, **Energy Efficient** and Custom. If Custom is selected, the following options become available:

EIST

EIST (Enhanced Intel SpeedStep Technology) allows the system to automatically adjust processor voltage and core frequency in an effort to reduce power consumption and heat dissipation. **Please refer to Intel's web site for detailed information.** The options are Disabled and **Enabled**.

Turbo Mode

This feature allows processor cores to run faster than marked frequency in specific conditions. The options are Disabled and **Enabled**.

CPU C3 Report, CPU C6 Report

This BIOS feature enables or disables C3 (ACPI C2) and C6 (ACPI C3) reporting to the operating system. The options are Disabled and **Enabled**.

Config TDP LOCK

Use this feature to lock the Config TDP Control register. The options are **Disabled** and Enabled.

Long Duration Power Limit

This is the processor power consumption limit (in Watts) during a long duration time window. The default setting is **0**.

Long Duration Maintained

This is the time in milliseconds where the Long Duration Power Limit is maintained. The default setting is **1**.

Short Duration Power Limit

During Turbo Mode, the system may exceed the processor's default power setting and exceed the Short Duration Power limit. By increasing this value, the processor can provide better performance for a short duration. The default setting is **0**.

ACPI T State

Select enabled for ACPI throttling state support. The options are Enabled and **Disabled**.

►Advanced Chipset Control



Warning: Setting the wrong values in the following sections may cause the system to malfunction.

►System Agent (SA) Configuration

This submenu allows you to configure System Agent Parameters.

►Memory Configuration

This section displays memory status such as memory speed and total memory.

Memory Frequency Limiter

Use this item to select the maximum memory frequency (in Mhz). The options are **Auto**, 1067, 1333, 1600, 1867, 2133, 2400, and 2667.

DDR Selection

Use this item to select the type of DDR. The options are DDR3, DDR3L, and **Auto**.

DDR Reset Wait Time

Enter the amount of time (in nano seconds) to wait for switch DDR voltage. The minimum value is 20ns. The default value is **2000000**.

ECC Support

Select Enabled to support ECC. The options are **Enabled** and Disabled.

Memory Scrambler

Select Enabled to support Memory Scrambler. The options are **Enabled** and Disabled.

VT-d

Select Enabled to enable Intel's Virtualization Technology support for Direct I/O VT-d by reporting the I/O device assignments to VMM through the DMAR ACPI Tables. This feature offers fully-protected I/O resource-sharing across the Intel platforms, providing the user with greater reliability, security and availability in networking and data-sharing. The settings are **Enabled** and Disabled.

PEG0 - Gen X

This feature selects the speed of the PEG0 port. The options are **Auto**, Gen1, Gen2, and Gen3.

PEG0 ASPM

Set this item to control ASPM (Active State Power Management) support for PEG: Device 1 Function 0. The options are Disabled, **Auto**, ASPM L0s, ASPM L1, and ASPM L0sL1.

Enable PEG

Use this feature to enable the PEG. The options are Disabled, Enabled, and **Auto**.

De-emphasis Control

This item sets the De-emphasis control on PEG. The options are -6 dB and **-3.5 dB**.

Initiate Graphic Adapter

Use this feature to select which device will operate as the primary display. The options are **Auto**, IGFX/PEG, PEG/On Board, and On Board/PEG. Note: selecting IGFX/PEG will enable the Intel HD 4000 GPU.

►PCH-IO Configuration

This submenu allows you to configure PCH Parameters.

►USB Configuration

Legacy USB Support

This feature enables support for legacy USB devices. Select Auto to disable legacy support if USB devices are not present. Select Disable to have USB devices available only for EFI applications. The options are **Enabled**, Disabled and Auto.

USB3.0 Support

This feature enables controller support for USB 3.0 (XHCI) in the BIOS. The options are **Enabled** and Disabled.

XHCI Hand-Off

This item is for Operating Systems that do not support Extensible Host Controller Interface (xHCI) hand-off. When enabled, xHCI ownership change will be claimed by the xHCI driver. The settings are **Enabled** and Disabled.

EHCI Hand-Off

This item is for Operating Systems that do not support Enhanced Host Controller Interface (EHCI) hand-off. When enabled, EHCI ownership change will be claimed by the EHCI driver. The settings are Enabled and **Disabled**.

XHCI Pre-Boot Driver

This feature enables support for the xHCI pre-boot driver. The options are **Enabled** and Disabled.

XHCI Mode

Use this feature to select the xHCI controller mode of operation. The options are **Smart Auto**, Auto, Enabled, and Disabled.

HS Port #1~#4 Switchable

This feature allows for HS port switching between xHCI and EHCI. When set to Disabled, the specified port is routed to EHCI. The options are **Enabled** and Disabled.



Note: If HS port is routed to xHCI, the corresponding SS port is enabled.

XHCI Streams

Use this feature to enable the maximum primary stream array size for xHCI. The options are **Enabled** and Disabled.

EHCI1, EHCI2

This feature enables the EHCI interface (USB 2.0). At least one EHCI controller must always be enabled. The options are **Enabled** and Disabled.

USB Ports Per-Port Disable Control

If set to Enabled, this feature allows deactivation of selected USB ports. The options are **Disabled** and Enabled. If set to Enabled, the following will appear:

USB Port #0~#13 Disable

Select which USB ports to disable. The settings are Enabled and **Disabled**.

Deep Sx (EUP)

Select Enabled to enable Deep Sleep State support. The settings are Enabled and **Disabled**.

SLP_S4 Assertion Width

Use this feature to select a minimum assertion width of the SLP_S4 signal. The options are Disabled, 1-2 Seconds, 2-3 Seconds, 3-4 Seconds, and **4-5 Seconds**.

►IDE/SATA Configuration

When this submenu is selected, the AMI BIOS automatically detects the presence of the SATA Devices and displays the following items:

SATA Controllers

This item enables or disables the on board SATA controller. The options are **Enabled** and Disabled:

SATA Mode Selection

This item selects the mode for the installed drives. The options are Disabled, IDE Mode, **AHCI Mode** and RAID Mode. The following are displayed depending on your selection:

IDE Mode

The following items are displayed when IDE Mode is selected:

Serial ATA Port 0~5

This item displays the information detected on the installed SATA drives on the particular SATA port.

AHCI Mode

The following items are displayed when AHCI Mode is selected:

Aggressive LPM Support

This feature Enables or Disables Aggressive Link Power Management support for Cougar Point B0 stepping and later. The options are **Enabled** and Disabled.

Serial ATA Port 0~5 Hot Plug

Set this item to Enabled to enable hot-plugging for the particular port. The options are Enabled and **Disabled**.

Serial ATA Port 0~5 Spin Up Device

Set this item to Enabled to enable device spin-up support. The options are Enabled and **Disabled**.

RAID Mode

The following items are displayed when RAID Mode is selected:

Serial ATA Port 0~5 Hot Plug

Set this item to Enabled to enable hot-plugging for the particular port. The options are Enabled and **Disabled**.

Serial ATA Port 0~5 Spin Up Device

Set this item to Enabled to enable device spin-up support. The options are Enabled and **Disabled**.

►PCIe/PCI/PnP Configuration

This feature allows the user to set the PCI/PnP configurations for the following items:

Launch PXE, Storage, Video OpROM Policy

In case of multiple Option ROMs (Legacy and UEFI-compatible), this feature specifies what ROM to launch. The options are Do not launch, UEFI only, and **Legacy only**.

Other PCI device ROM priority

This feature specifies what ROM to launch for PCI devices other than network, mass storage or video. The options are UEFI OpROM and **Legacy OpROM**.

PCI Latency Timer

This feature sets the latency Timer of each PCI device installed on a PCI bus. Select 64 to set the PCI latency to 64 PCI clock cycles. The options are 32 PCI Bus Clocks, **64 PCI Bus Clocks**, 96 PCI Bus Clocks, 128 PCI Bus Clocks, 160 PCI Bus Clocks, 192 PCI Bus Clocks, 224 PCI Bus Clocks and 248 PCI Bus Clocks.

PERR# Generation

Set this item to Enabled to allow PCI devices to generate PERR# error codes. The options are **Enabled** and Disabled.

SERR# Generation

Set this item to Enabled to allow PCI devices to generate SERR# error codes. The options are **Enabled** and Disabled.

ASPM Support

Set this item to the desired ASPM (Active State Power Management) level. The options are **Disabled**, Auto and Force L0s.

Maximum Payload

This feature selects the setting for the PCIe maximum payload size. The options are **Auto**, 128 Bytes, and 256 Bytes, 512 Bytes, 1024 Bytes, 2048 Bytes, and 4096 Bytes.

Maximum Read Request

This feature selects the setting for the PCIe maximum Read Request size. The options are **Auto**, 128 Bytes, 256 Bytes, 512 Bytes, 1024 Bytes, 2048 Bytes, and 4096 Bytes.

Above 4G Decoding

Set this item to Enabled to activate 64-bit capable devices to be decoded above the 4G address space. This works only if the system supports 64-bit PCI decoding. The options are Enabled and **Disabled**.

VGA Palette Snoop

When enabled, this feature allows video add-on cards to borrow the color palette from the system's video card. The options are Enabled and **Disabled**.

►PCI Express Settings**Relaxed Ordering**

Select Enabled to allow certain PCI-E transactions to violate the strict ordering rules of PCI-E so that a transaction can be completed before other transactions that have already been queued in order to enhance PCI-E performance. The options are **Disabled** and Enabled.

Extended Tag

Select Enabled to allow a PCI Express device to use 8-bit tag field as a requester. The options are **Disabled** and Enabled.

No Snoop

Select Enabled to activate the PCI Express no snoop option. The options are Disabled and **Enabled**.

Maximum Payload

This feature selects the setting for the PCI Express maximum payload size. The options are **Auto**, 128 Bytes, and 256 Bytes, 512 Bytes, 1024 Bytes, 2048 Bytes, and 4096 Bytes.

Maximum Read Request

This feature selects the setting for the PCI Express maximum Read Request size. The options are **Auto**, 128 Bytes, 256 Bytes, 512 Bytes, 1024 Bytes, 2048 Bytes, and 4096 Bytes.

ASPM Support

Set this item to the desired ASPM (Active State Power Management) level. The options are **Disabled**, Auto and Force L0s.

Extended Synch

Select Enabled for Extended Synchronization support, which will extend the same synchronization patterns for the PCI-E device. The options are **Disabled** and Enabled.

Link Training Retry

This feature allows the user to decide how many attempts a software program can make before time-out for the program. The default setting is 5. The options are Disabled, 2, 3, and 5.

Link Training Timeout (US)

This feature allows the user to decide how many microseconds a software program should wait before polling the 'Link Training' bit in the Link Status Register. The range is between 10 to 1000. The default setting is **500**.

Unpopulated Links

Select Disable Link to disable the unpopulated PCI-E links (connections) to save power. The options are **Keep Link ON** and Disable.

► PCI Express GEN 2 Settings

Completion Timeout

For device functions that support completion timeout programmability, this feature allows system software to modify the completion timeout value. If Default is selected, the timeout value is 50us to 50ms. If Shorter is selected, the software will use shorter timeout ranges supported by the hardware. If Longer is selected, software will use longer ranges supported by the hardware. The options are **Default**, Shorter, Longer, and Disabled.

ARI Forwarding (Available when supported by the hardware)

If set to Enabled, the downstream port disables its traditional Device Number field (0 enforcement) when turning a Type1 Configuration Request into a Type0

Configuration Request, permitting access to Extended Functions in an ARI device immediately below the port. The options are **Disabled** and Enabled.

AtomicOp Requester Enable (Available when supported by the hardware)

When set to Enabled, this feature initiates AtomicOp requests only if Bus Master Enable bit is in the Command Register set. The options are **Disabled** and Enabled.

AtomicOp Egress Blocking (Available when supported by the hardware)

When set to Enabled, this feature blocks outbound AtomicOp Requests via Egress ports. The options are **Disabled** and Enabled.

IDO Request Enable (Available when supported by the hardware)

When set to Enabled, this feature permits setting the number of ID-Based Ordering (IDO) bit (Attribute[2]) requests to be initiated. The options are **Disabled** and Enabled.

IDO Completion Enable (Available when supported by the hardware)

When set to Enabled, this feature permits setting the number of ID-Based Ordering (IDO) bit (Attribute[2]) requests to be initiated. The options are **Disabled** and Enabled.

LTR Mechanism Enable (Available when supported by the hardware)

When set to Enabled, this feature enables the Latency Tolerance Reporting mechanism. The options are **Disabled** and Enabled.

End-End TLP Prefix Blocking (Available when supported by the hardware)

When set to Enabled, this feature blocks forwarding of TLPs containing End-End TLP prefixes.

Target Link Speed (Available when supported by the hardware)

When set to Force to 2.5 or 5.0 GT/s, this feature sets an upper limit on the link operational speed of downstream ports by restricting the values advertised by the upstream component in its training sequences. When set to Auto, HW initialized data will be used. The options are **Auto**, Force to 2.5 GT/s, and Force to 5.0 GT/s.

Clock Power management (Available when supported by the hardware)

When set to Enabled, this feature permits the device to use CLKREQ# signal for power management of link clock in accordance to protocol defined in appropriate form factor specification. The options are **Disabled** and Enabled.

Compliance SOS (Available when supported by the hardware)

When set to Enabled, this feature will force LTSSM to send SKP ordered sets between sequences when sending compliance pattern or modified compliance pattern. The options are **Disabled** and Enabled.

Hardware Autonomous Width (Available when supported by the hardware)

When set to Disabled, this feature disables the hardware's ability to change link width (except width size reduction) for the purpose of correcting unstable link operation. The options are **Enabled** and Disabled.

Hardware Autonomous Speed (Available when supported by the hardware)

When set to Disabled, this feature disables the hardware's ability to change link speed (except speed size reduction) for the purpose of correcting unstable link operation. The options are **Enabled** and Disabled.

PCI-E Slot 1 Option ROM

Use this feature to enable or disable PCI-E slot 1 Option ROM. The options are Disabled and **Enabled**.

Onboard LAN Option ROM Select

This feature selects whether to load the iSCSI or PXE onboard LAN option ROM. The options are iSCSI and **PXE**.

Onboard LAN 1 ~ LAN 4

Use this item to enable or disable onboard LAN for the specified port. The options are **Enabled** and Disabled.

Load Onboard LAN 1 ~ LAN 4 Option ROM

This feature is to enable or disable the onboard option ROMs. The options are Disabled and Enabled. The default for LAN 1 is **Enabled**. Default for LAN 2 ~ LAN 4 is **Disabled**.

Network Stack

Set this item to Enabled to activate the Network Stack (PXE and UEFI). The options are Enabled and **Disabled**. When enabled, the following options appear:

Ipv4 PXE Support

This feature enables Ipv4 boot support. If disabled, an Ipv4 PXE boot option will not be created. The options are **Enabled** and Disabled.

Ipv6 PXE Support

This feature enables Ipv6 boot support. If disabled, an Ipv6 PXE boot option will not be created. The options are Enabled and **Disabled**.

► Super IO Device Configuration

► Serial Port 1 Configuration / Serial Port 2 Configuration

Serial Port 1 / Serial Port 2

Select Enabled to enable the onboard serial port. The options are **Enabled** and Disabled.

Serial Port 1 Settings / Serial Port 2 Settings

This option specifies the base I/O port address and the Interrupt Request address of Serial Port 1 and Serial Port 2. Select Disabled to prevent the serial port from accessing any system resources. When this option is set to Disabled, the serial port becomes unavailable.

The options for Serial Port 1 are:

Auto,

IO=3F8h; IRQ=4;

IO=3F8h; IRQ=4, 10, 11;

IO=2F8h; IRQ=3, 10, 11;

IO=3E8h; IRQ=4, 10, 11;

IO=2E8h; IRQ=3, 10, 11;

The options for Serial Port 2 are:

Auto,

IO=2F8h; IRQ=3;

IO=3F8h; IRQ=4, 10, 11;

IO=2F8h; IRQ=3, 10, 11;

IO=3E8h; IRQ=4, 10, 11;

IO=2E8h; IRQ=3, 10, 11;

►Remote Access Configuration

COM1, COM2, SOL Console Redirection

Use this feature to enable console redirection for COM1, and COM2 ports. The options are Enabled and Disabled. The default for COM1 and COM2 is **Disabled**. The default for SOL is **Enabled**.

►Console Redirection Settings

This feature allows the user to specify how the host computer will exchange data with the client computer, which is the remote computer used by the user.

Terminal Type

This feature allows the user to select the target terminal emulation type for Console Redirection. Select VT100 to use the ASCII character set. Select VT100+ to add color and function key support. Select ANSI to use the extended ASCII character set. Select VT-UTF8 to use UTF8 encoding to map Unicode characters into one or more bytes. The options are ANSI, **VT100**, VT100+, and VT-UTF8.

Bits Per Second

This item sets the transmission speed for a serial port used in Console Redirection. Make sure that the same speed is used in the host computer and the client computer. A lower transmission speed may be required for long and busy lines. The options are 9600, 19200, 38400, 57600, and **115200** (bits per second).

Data Bits

Use this feature to set the data transmission size for Console Redirection. The options are 7 and **8** (Bits).

Parity

A parity bit can be sent along with regular data bits to detect data transmission errors. Select Even if the parity bit is set to 0, and the number of 1's in data bits is even. Select Odd if the parity bit is set to 0, and the number of 1's in data bits is odd. Select None if you do not want to send a parity bit with your data bits in transmission. Select Mark to add mark as a parity bit to be sent along with the data bits. Select Space to add a Space as a parity bit to be sent with your data bits. The options are **None**, Even, Odd, Mark, and Space.

Stop Bits

A stop bit indicates the end of a serial data packet. Select 1 Stop Bit for standard serial data communication. Select 2 Stop Bits if slower devices are used. The options are **1** and 2.

Flow Control

This feature allows the user to set the flow control for Console Redirection to prevent data loss caused by buffer overflow. Send a "Stop" signal to stop sending data when the receiving buffer is full. Send a "Start" signal to start sending data when the receiving buffer is empty. The options are **None** and Hardware RTS/CTS.

VT-UTF8 Combo Key Support

Select Enabled to enable VT-UTF8 Combination Key support for ANSI/VT100 terminals. The options are **Enabled** and Disabled.

Recorder Mode

Select Enabled to capture the data displayed on a terminal and send it as text messages to a remote server. The options are **Disabled** and Enabled.

Resolution 100x31

Select Enabled for extended-terminal resolution support. The options are Disabled and **Enabled**.

Legacy OS Redirection Resolution

Use this feature to select the number of rows and columns used in Console Redirection for legacy OS support. The options are 80x24 and **80x25**.

Putty Keypad

Use this feature to select function key and keypad setting on Putty. The options are **VT100**, LINUX, XTERMR6, SCO, ESCN, and VT400.

Redirection After BIOS POST

When set to BootLoader, legacy console redirection is disabled before booting to legacy OS. When set to Always Enable, legacy console redirection is enabled for legacy OS. The options are **Always Enable** and BootLoader.

Serial Port for Out-of-Band Management/Windows Emergency Management Services (EMS)

This item allows the user to configure Console Redirection settings to support Out-of-Band Serial Port management.

Console Redirection (for EMS)

Select Enabled to use a COM Port selected by the user for Console Redirection. The options are Enabled and **Disabled**.

► Console Redirection Settings (for EMS)

This feature allows the user to specify how the host computer will exchange data with the client computer, which is the remote computer used by the user.

Out-of-Band-Mgmt Port

Use this feature to select the port for out-of-band management. The options are **COM1**, COM2, and SOL.

Terminal Type

This feature allows the user to select the target terminal emulation type for Console Redirection. Select VT100 to use the ASCII character set. Select VT100+ to add color and function key support. Select ANSI to use the extended ASCII character set. Select VT-UTF8 to use UTF8 encoding to map Unicode characters into one or more bytes. The options are ANSI, VT100, VT100+, and **VT-UTF8**.

Bits Per Second

This item sets the transmission speed for a serial port used in Console Redirection. Make sure that the same speed is used in the host computer and the client computer. A lower transmission speed may be required for long and busy lines. The options are 9600, 19200, 57600, and **115200** (bits per second).

Flow Control

This feature allows the user to set the flow control for Console Redirection to prevent data loss caused by buffer overflow. Send a "Stop" signal to stop sending data when the receiving buffer is full. Send a "Start" signal to start sending data when the receiving buffer is empty. The options are **None**, Hardware RTS/CTS, and Software Xon/Xoff.

► ACPI Configuration

Use this feature to configure Advanced Configuration and Power Interface (ACPI) power management settings for your system.

High Precision Timer

Select Enabled to activate the High Performance Event Timer (HPET) that produces periodic interrupts at a much higher frequency than a Real-time Clock (RTC) does in synchronizing multimedia streams, providing smooth playback and reducing the dependency on other timestamp calculation devices, such as an x86 RDTSC Instruction embedded in the CPU. The High Performance Event Timer is used to replace the 8254 Programmable Interval Timer. The options are **Enabled** and Disabled.

ACPI Sleep State

This setting allows you to configure the ACPI (Advanced Configuration and Power Interface) sleep state for your system when it is in the Suspend mode. The options are Suspend Disabled, S1 only (CPU Stop Clock), S3 only (Suspend to RAM), and **Both S1 and S3 available for OS to choose from**. S3 (Suspend to RAM) is the deepest sleep state in these options.

PS2 KB/MS Wake up

Use this feature to select the PS2 Keyboard/Mouse wake up setting. The options are **S1 (OS Control)**, S5 (OS Control), Force Enable, and Force Disable.

►Trusted Computing Configuration

Security Device Support

This feature enables or disables the BIOS support for a security device. The options are Disable and **Enable**. Note that the OS will not reveal the security device. Also, the TCG EFI protocol and the INT1A interface will not be available.

►Intel TXT(LT) Configuration

Secure Mode Extensions (SMX)

This feature can be configured if it is supported by the processor. Enable this feature to activate Intel TXT, below. The options are Enabled and **Disabled**.

Intel TXT (LT) Support

Intel TXT (Trusted Execution Technology) helps protect against software-based attacks and ensures protection, confidentiality and integrity of data stored or created on the system. The options are Enabled and **Disabled**.

iSCSI Configuration

When sharing the iSCSI devices on this machine (iSCSI target), this section is used to enter the worldwide unique name of an iSCSI initiator. An iSCSI initiator application must be configured on the machine that will access the iSCSI drives in this machine.

iSCSI Initiator Name

Only IQN (iSCSI Qualified Names) names are accepted. For more information on iSCSI, research RFC 3720 and RFC 3721 at the Internet Engineering Task Force website (IETF -- www.ietf.org).

Add an Attempt

The settings on this section are setup parameters to connect to a remote iSCSI device.

iSCSI Attempt Name - assigns a unique name to this attempt.

iSCSI Mode - select Enabled or **Disabled**

Connection Retry Count - if the initial connection fails or times out, this is how many times an attempt will be made to connect.

Connection Establishing Timeout - This is the time in milliseconds the system will wait for a connection until it times out. The minimum is 100ms and the maximum is 20 secs.

ISID - This is the OUI-format ISID. The default value is taken from the device's MAC address. Only the last 3 bytes are configurable.

Enable DHCP - Select Enabled to allow a DHCP server to assign the IP addresses for this attempt. If this is set to **Disabled**, then you need to enter the Initiator IP Address, Subnet Mask and Gateway manually.

Target Name - Enter the qualified domain name of the target iSCSI device.

Target IP Address - Enter the IP Address of the target iSCSI device.

Target Port - Enter the port address of the target iSCSI device.

Boot LUN - This is the target's LU number in Hexadecimal format.

Authentication Type - Select **CHAP** or None.

If CHAP is selected above:

CHAP Type - Select **One Way** or Mutual.

CHAP Secret - Assign a secret word that is also defined in the target iSCSI device. Minimum length is 12 bytes and maximum is 16 bytes.

When finished, select Save Changes.

Delete Attempts

This feature deletes previously defined attempts as above.

Change Attempt Order

This feature changes the order in which several iSCSI connection attempts are made.

Intel(R) 82579LM / Intel(R) 82574L Gigabit Network Connection

►NIC Configuration

Link Speed

Use this feature to select the link speed to be used. The options are **AutoNeg**, 10 Mbps Half, 10 Mbps Full, 100 Mbps Half and 100 Mbps Full.

Wake On LAN

Use this feature to activate the Wake On LAN (WOL) feature. The options are **Enabled**, and Disabled.

Blink LEDs (Range 0-15 seconds)

Please specifies the blink rate of the NIC LED. Select from 1-15 second intervals.

Port Configuration Information

This section displays the current configuration of the Network Interface.

4-4 Event Logs

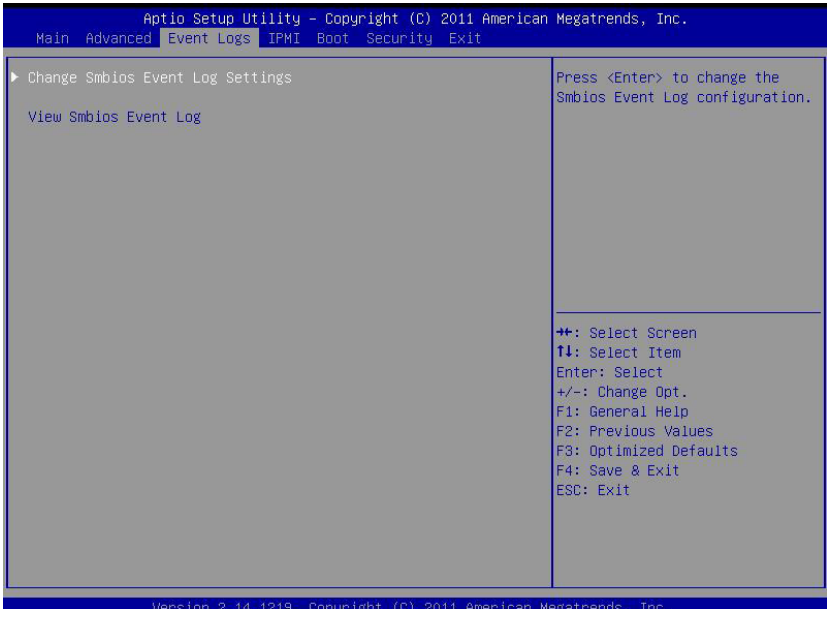

► Change SmbIOS Event Log Settings

Smbios Event Log

Change this item to enable or disable all features of the Smbios Event Logging during boot. The options are **Enabled** and Disabled.

Erase Event Log

This option erases all logged events. The options are **No**, Yes, Next reset and Yes, Every reset.

When Log is Full

This option automatically clears the Event Log memory of all messages when it is full. The options are **Do Nothing** and Erase Immediately.

Log System Boot Event

This option toggles the System Boot Event logging to enabled or disabled. The options are **Disabled** and Enabled.

MECI

The Multiple Event Count Increment (MECI) counter counts the number of occurrences a duplicate event must happen before the MECI counter is incremented. This is a numeric value.

METW

The Multiple Event Time Window (METW) defines number of minutes must pass between duplicate log events before MECI is incremented. This is in minutes, from 0 to 99.

View SmbIOS Event Log

This feature displays the contents of the SmbIOS Event Log.

4-5 IPMI Settings

Intelligent Platform Management Interface (IPMI) is a set of common interfaces that IT administrators can use to monitor system health and to manage the system as a whole. For more information on the IPMI specifications, please visit Intel's website at www.intel.com.



▶ System Event Log

This feature is used to change the System Event Log (SEL) configuration.

SEL Components - Change this item to enable or disable all features of System Event Logging. The options are **Enabled** and Disabled. When Enabled, the following can be configured:

Erase SEL - This option erases all logged SEL events. The options are **No**, Yes, On Next reset and Yes, On Every reset.

When SEL Full

This option automatically clears the System Event Log memory of all messages when it is full. The options are **Do Nothing** and Erase Immediately.

Log EFI Status Codes

This option enables or disables the logging of Extensible Firmware Interface (EFI) status codes. The options are Disabled, and **Enabled**.

►BMC Network Configuration

Set this feature to configure the IPMI LAN adapter with a network address.

Update IPMI LAN Configuration

This feature allows the user to decide if the BIOS should configure the IPMI setting at next system boot. The options are **No** and Yes. If the option is set to Yes, the user is allowed to configure the IPMI settings at next system boot.

Configuration Source

This feature selects whether the IP address, Subnet Mask and Gateway Address are automatically assigned by the network's DHCP (Dynamic Host and Configuration Protocol) server or manually entered by the user (Static). When DHCP is selected, all the options below are automatically assigned to the system by itself or by an external DHCP server. If Static is selected, the IP Address, Subnet Mask and Gateway Address must be manually entered below. The options are Static and **DHCP**.

Station IP Address - Enter the IP address for this machine. This should be in decimal and in dotted quad form (i.e., 192.168.10.253). The value of each three-digit number separated by dots should not exceed 255.

Subnet Mask - Subnet masks tell the network which subnet this machine belongs to. The value of each three-digit number separated by dots should not exceed 255.

Station MAC Address - MAC addresses are 6 two-digit hexadecimal numbers (Base 16, 0 ~ 9, A, B, C, D, E, F) separated by dots (i.e., 00.30.48.D0.D4.60).

Gateway IP Address - Enter the Gateway or Router address (i.e., 192.168.10.1).

4-6 Boot

Use this feature to configure Boot Settings:

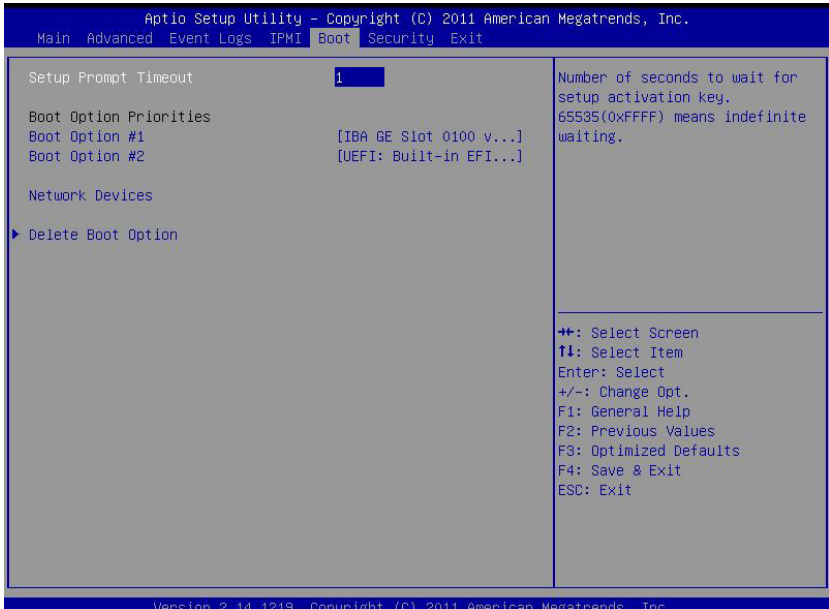

Setup Prompt Timeout

Use this feature to enter the number of seconds to wait for setup activation key. The default setting is **1** second.

Boot Options Priorities

This feature allows the user to specify which devices are boot devices and the order of priority from which the system boots during startup.

Boot Option #1, Boot option #2, Boot Option #3, etc

The settings are [**any detected boot device**] and Disabled.

USB Device BBS Priorities

Network Devices

This option sets the order of the legacy network devices detected by the motherboard.

►Delete Boot Option

This feature allows the user to delete a previously defined boot device from which the systems boots during startup.

4-7 Security Settings

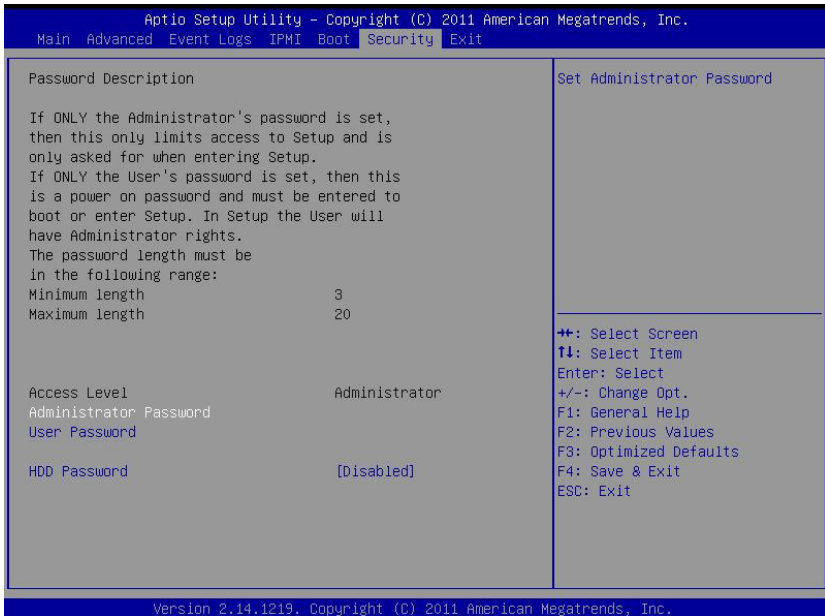

- If the Administrator password is defined ONLY - this controls access to the BIOS setup ONLY.
- If the User's password is defined ONLY - this password will need to be entered during each system startup or boot, and will also have Administrator rights in the setup.
- Passwords must be at least 3 and up to 20 characters long.

Administrator Password

Press Enter to create a new, or change an existing Administrator password.

User Password:

Press Enter to create a new, or change an existing User password.

HDD Password:

Select Enable to activate Hard Disk Drive password support. The options are Enabled and **Disabled**.

4-8 Exit

Select the Exit tab from the BIOS Setup Utility screen to enter the Exit BIOS Setup screen.

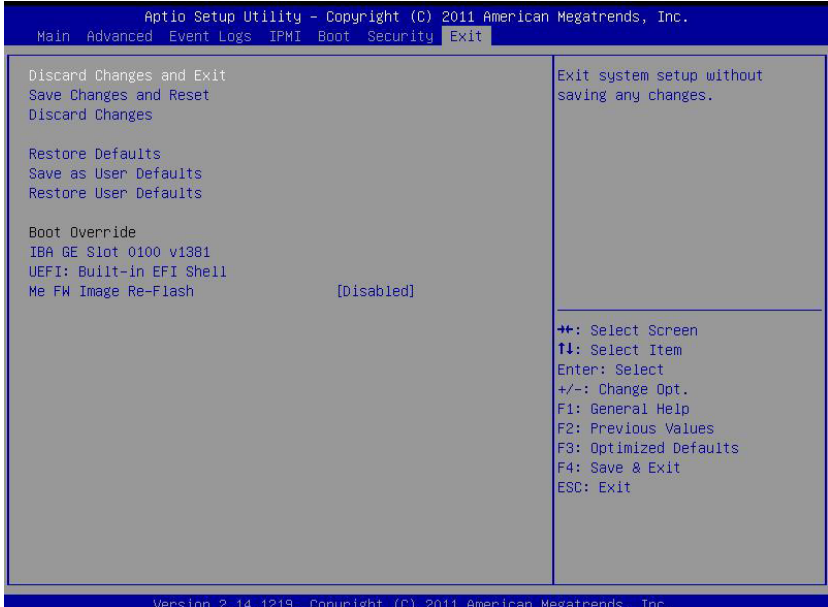

Discard Changes and Exit

Select this option to quit the BIOS Setup without making any permanent changes to the system configuration, and reboot the computer. Select Discard Changes and Exit from the Exit menu and press <Enter>.

Save Changes and Reset

When you have completed the system configuration changes, select this option to leave the BIOS Setup Utility and reboot the computer, so the new system configuration parameters can take effect. Select Save Changes and Exit from the Exit menu and press <Enter>.

Discard Changes

Select this option and press <Enter> to discard all the changes and return to the AMI BIOS Utility Program.

Restore Defaults

To set this feature, select Restore Defaults from the Exit menu and press <Enter>. These are factory settings designed for maximum system stability, but not for maximum performance.

Save As User Defaults

To set this feature, select Save as User Defaults from the Exit menu and press <Enter>. This enables the user to save any changes to the BIOS setup for future use

Restore User Defaults

To set this feature, select Restore User Defaults from the Exit menu and press <Enter>. Use this feature to retrieve user-defined settings that were saved previously.

Boot Override

Listed on this section are other boot options for the system (i.e., Built-in EFI shell). Select an option and press <Enter>. Your system will boot to the selected boot option. This is a one-time override.

IBA IGE Slot 0100 v1381

This item will attempt to boot from the Network Boot Device.

UEFI: Built-in EFI Shell

This item attempts to launch EFI shell application (Shellx64.efi) from one of the available filesystem devices.

Me FW Image Re-Flash

Use this item to enable the ME image re-flash function. The options are **Disabled** and **Enabled**.

Appendix A

POST Error Beep Codes

This section lists POST (Power On Self Test) error beep codes for the AMI BIOS. POST error beep codes are divided into two categories: recoverable and terminal. This section lists Beep Codes for recoverable POST errors.

Recoverable POST Error Beep Codes

When a recoverable type of error occurs during POST, BIOS will display a POST code that describes the problem. BIOS may also issue one of the following beep codes:

- 1 long and two short beeps - video configuration error
- 1 repetitive long beep - no memory detected
- 1 continuous beep with the front panel Overheat LED on - system overheat
- 8 short beeps - display memory read/write error

Notes

Appendix B

Software Installation Instructions

B-1 Installing Drivers

Additional drivers and tools for your motherboard are available for download at the Supermicro website. To install these software programs and drivers, run the application and a screen will appear as below. Click the icons to the right of these items.

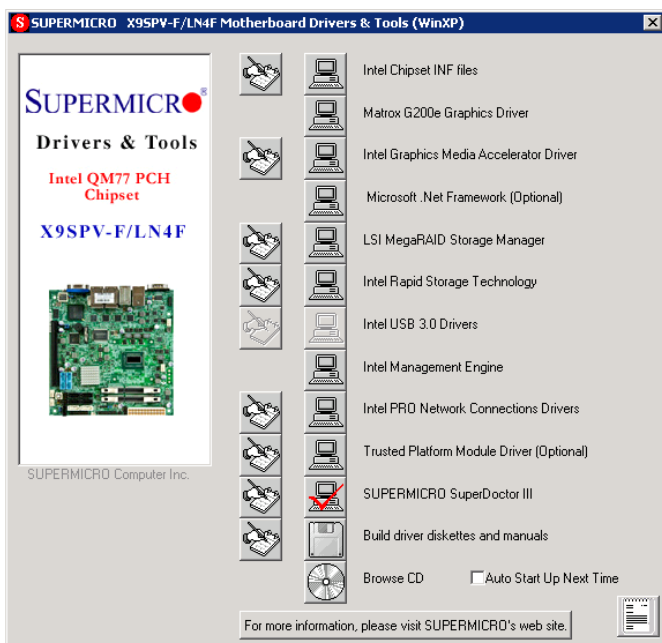

Driver/Tool Installation Display Screen



Note: Click the icons showing a hand writing on the paper to view the readme files for each item. Click a computer icon to the right of an item to install an item (from top to the bottom) one at a time. After installing each item, you must re-boot the system before proceeding with the next item on the list. The bottom icon with a CD on it allows you to view the entire contents of the CD.

B-2 Configuring SuperDoctor III

The SuperDoctor III program is a Web-base management tool that supports remote management capability. It includes Remote and Local Management tools. The local management is called the SD III Client. The SuperDoctor III program included on the CDROM that came with your motherboard allows you to monitor the environment and operations of your system. SuperDoctor III displays crucial system information such as CPU temperature, system voltages and fan status. See the Figure below for a display of the Supero Doctor III interface.



Note 1: Both default user name and password are ADMIN.



Note 2: In the Windows OS environment, the SuperDoctor III settings take precedence over the BIOS settings. When first installed, SuperDoctor III adopts the temperature threshold settings previously set in the BIOS. Any subsequent changes to these thresholds must be made within SuperDoctor, since the SD III settings override the BIOS settings. For the Windows OS to adopt the BIOS temperature threshold settings, please change the SDIII settings to be the same as those set in the BIOS.

SuperDoctor III Interface Display Screen-I (Health Information)



SuperDoctor III Interface Display Screen-II (Remote Control)



Note: SD III Software Revision 1.0 can be downloaded from our Web site at: ftp://ftp.supermicro.com/utility/Super_Doctor_III/. You can also download SDIII User's Guide at: <http://www.supermicro.com/PRODUCT/Manuals/SDIII/UserGuide.pdf>. For Linux, we will still recommend that you use SuperDoctor II.

Notes

Appendix C

UEFI BIOS Recovery Instructions



Warning: Do not upgrade the BIOS unless your system has a BIOS-related issue. Flashing the wrong BIOS can cause irreparable damage to the system. In no event shall Supermicro be liable for direct, indirect, special, incidental, or consequential damages arising from a BIOS update. If you need to update the BIOS, do not shut down or reset the system while the BIOS is updating to avoid possible boot failure.

C-1 An Overview to the UEFI BIOS

The Unified Extensible Firmware Interface (UEFI) specification provides a software-based interface between the operating system and the platform firmware in the pre-boot environment. The UEFI specification supports an architecture-independent mechanism for add-on card initialization to allow the UEFI OS loader, which is stored in the add-on card, to boot up the system. UEFI offers a clean, hand-off control to a computer system at bootup.

C-2 How to Recover the UEFI BIOS Image (-the Main BIOS Block)

An AMIBIOS flash chip consists of a boot sector block and a main BIOS code block (a main BIOS image). The boot sector block contains critical BIOS codes, including memory detection and recovery codes for the user to flash a new BIOS image if the original BIOS image is corrupted. When the system power is on, the boot sector codes execute first. Once it is completed, the main BIOS code will continue with system initialization and bootup.



Note: Follow the BIOS Recovery instructions below for BIOS recovery when the main BIOS block crashes. However, when the BIOS Boot sector crashes, you will need to send the motherboard back to Supermicro for RMA repair.

C-3 To Recover the Boot Sector Using a USB-Attached Device

This feature allows the user to recover a BIOS image using a USB-attached device without additional utilities used. A USB flash device such as a USB Flash Drive, or

a USB CD/DVD ROM/RW device can be used for this purpose. However, a USB Hard Disk drive cannot be used for BIOS recovery at this time.

To perform UEFI BIOS recovery using a USB-attached device, follow the instructions below.

1. Using a different machine, copy the "Super.ROM" binary image file into the disc Root "\\" Directory of a USB device or a writeable CD/DVD.



Note: If you cannot locate the "Super.ROM" file in your driver disk, visit our website at www.supermicro.com to download the BIOS image into a USB flash device and rename it to "Super ROM" for BIOS recovery use.

2. Insert the USB device that contains the new BIOS image ("Super.ROM") into your USB drive and power on the system
3. While powering on the system, keep pressing <Ctrl> and <Home> simultaneously on your PS2 keyboard until your hear two short beeps. This may take from a few seconds to one minute.
4. After locating the new BIOS binary image, the system will enter the BIOS Recovery menu as shown below.

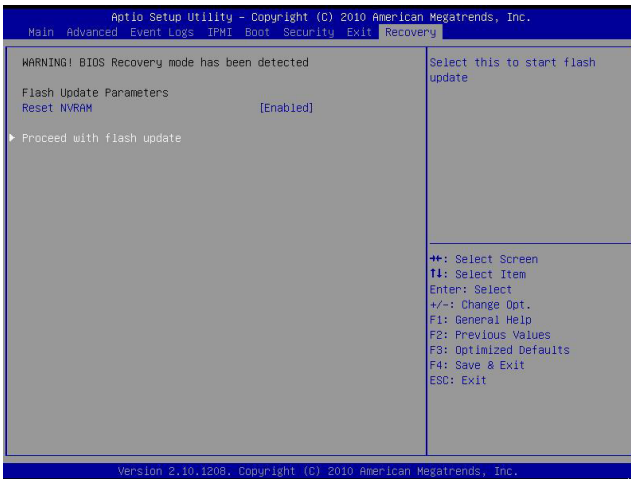

Note: At this point, you may decide if you want to start with BIOS Recovery. If you decide to proceed with BIOS Recovery, follow the procedures below.

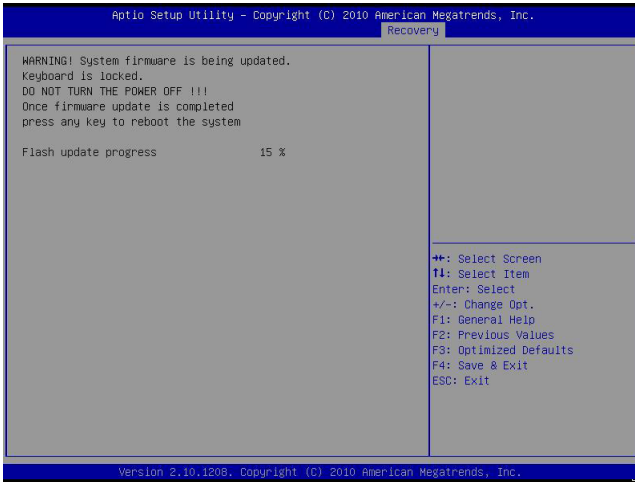

- When the screen as shown above displays, using the arrow key, select the item- "Proceed with flash update" and press the <Enter> key. You will see the progress of BIOS Recovery as shown in the screen below.

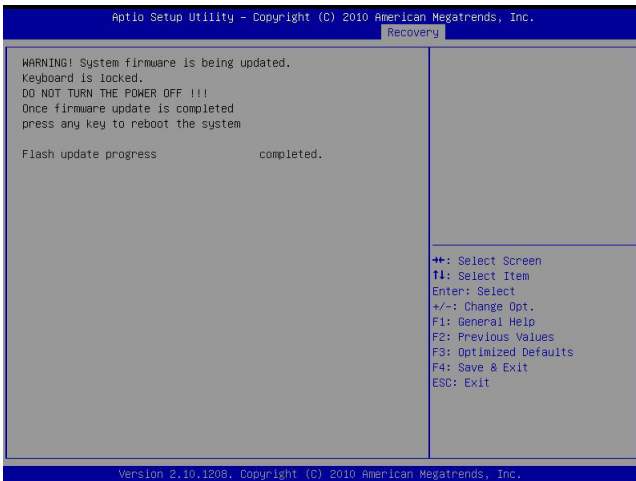

Note: Do not interrupt the process of BIOS flashing until it is completed.

- After the process of BIOS Recovery is complete, press any key to reboot the system.
- Using a different system, extract the BIOS package into a bootable USB flash drive.

8. When a DOS prompt appears, enter AMI.BAT BIOSname.### at the prompt.



Note: Do not interrupt this process until BIOS flashing is completed.

9. After seeing the message that BIOS update is completed, unplug the AC power cable from the power supply to clear CMOS, and then plug the AC power cable in the power supply again to power on the system.
10. Press continuously to enter the BIOS Setup utility.
11. Press <F3> to load default settings.
12. After loading default settings, press <F4> to save the settings and exit the BIOS Setup utility.

(Disclaimer Continued)

The products sold by Supermicro are not intended for and will not be used in life support systems, medical equipment, nuclear facilities or systems, aircraft, aircraft devices, aircraft/emergency communication devices or other critical systems whose failure to perform be reasonably expected to result in significant injury or loss of life or catastrophic property damage. Accordingly, Supermicro disclaims any and all liability, and should buyer use or sell such products for use in such ultra-hazardous applications, it does so entirely at its own risk. Furthermore, buyer agrees to fully indemnify, defend and hold Supermicro harmless for and against any and all claims, demands, actions, litigation, and proceedings of any kind arising out of or related to such ultra-hazardous use or sale.