



X11SWN-H/-E/-L/-C
X11SWN-H/-E/-L/-C-WOHS

USER MANUAL

Revision 1.1

The information in this user's manual has been carefully reviewed and is believed to be accurate. The vendor assumes no responsibility for any inaccuracies that may be contained in this document, and makes no commitment to update or to keep current the information in this manual, or to notify any person or organization of the updates. **Please Note: For the most up-to-date version of this manual, please see our website at www.supermicro.com.**

Super Micro Computer, Inc. ("Supermicro") reserves the right to make changes to the product described in this manual at any time and without notice. This product, including software and documentation, is the property of Supermicro and/or its licensors, and is supplied only under a license. Any use or reproduction of this product is not allowed, except as expressly permitted by the terms of said license.

IN NO EVENT WILL Super Micro Computer, Inc. BE LIABLE FOR DIRECT, INDIRECT, SPECIAL, INCIDENTAL, SPECULATIVE OR CONSEQUENTIAL DAMAGES ARISING FROM THE USE OR INABILITY TO USE THIS PRODUCT OR DOCUMENTATION, EVEN IF ADVISED OF THE POSSIBILITY OF SUCH DAMAGES. IN PARTICULAR, SUPER MICRO COMPUTER, INC. SHALL NOT HAVE LIABILITY FOR ANY HARDWARE, SOFTWARE, OR DATA STORED OR USED WITH THE PRODUCT, INCLUDING THE COSTS OF REPAIRING, REPLACING, INTEGRATING, INSTALLING OR RECOVERING SUCH HARDWARE, SOFTWARE, OR DATA.

Any disputes arising between manufacturer and customer shall be governed by the laws of Santa Clara County in the State of California, USA. The State of California, County of Santa Clara shall be the exclusive venue for the resolution of any such disputes. Supermicro's total liability for all claims will not exceed the price paid for the hardware product.

FCC Statement: This equipment has been tested and found to comply with the limits for a Class B digital device pursuant to Part 15 of the FCC Rules. These limits are designed to provide reasonable protection against harmful interference when the equipment is operated in a commercial environment. This equipment generates, uses, and can radiate radio frequency energy and, if not installed and used in accordance with the manufacturer's instruction manual, may cause harmful interference with radio communications. Operation of this equipment in a residential area is likely to cause harmful interference, in which case you will be required to correct the interference at your own expense.

California Best Management Practices Regulations for Perchlorate Materials: This Perchlorate warning applies only to products containing CR (Manganese Dioxide) Lithium coin cells. "Perchlorate Material-special handling may apply. See www.dtsc.ca.gov/hazardouswaste/perchlorate.



WARNING: This product can expose you to chemicals including lead, known to the State of California to cause cancer and birth defects or other reproductive harm. For more information, go to www.P65Warnings.ca.gov.

The products sold by Supermicro are not intended for and will not be used in life support systems, medical equipment, nuclear facilities or systems, aircraft, aircraft devices, aircraft/emergency communication devices or other critical systems whose failure to perform be reasonably expected to result in significant injury or loss of life or catastrophic property damage. Accordingly, Supermicro disclaims any and all liability, and should buyer use or sell such products for use in such ultra-hazardous applications, it does so entirely at its own risk. Furthermore, buyer agrees to fully indemnify, defend and hold Supermicro harmless for and against any and all claims, demands, actions, litigation, and proceedings of any kind arising out of or related to such ultra-hazardous use or sale.

Manual Revision 1.1

Release Date: April 11, 2022

Unless you request and receive written permission from Super Micro Computer, Inc., you may not copy any part of this document. Information in this document is subject to change without notice. Other products and companies referred to herein are trademarks or registered trademarks of their respective companies or mark holders.

Copyright © 2022 by Super Micro Computer, Inc.
All rights reserved.

Printed in the United States of America

Preface

About This Manual

This manual is written for system integrators, IT technicians and knowledgeable end users. It provides information for the installation and use of the X11SWN-H/-E/-L/-C, X11SWN-H/-E/-L/-C-WOHS motherboard.

About This Motherboard

The Supermicro X11SWN is a 3.5" Single Board Computer that is powered by the 8th generation of Intel® Core™ U series processor, which operates on low power and features a TDP of 15W to provide high performance computing and multimedia capabilities.

Based on numerous demands from embedded applications, Supermicro has developed an optimized thermal solution for X11SWN, producing a fanless design with compact size on this high performance platform.

X11SWN adopts the latest 64-bit, up to quad-core processors built on 14nm process technology for improvements in CPU processing, graphics, security, and I/O flexibility.

In addition, X11SWN is equipped with the latest generation graphics core (Intel® UHD Graphics 620) with DirectX 12, OpenGL 4.5, OpenCL 2.1 and 4K encoding/decoding, which increases more possibilities for multimedia application development. X11SWN-H/E, with Intel Core i7 and Core i5, supports Intel® vPro™ Technology and Intel® Active Management Technology (AMT).

This is a high performance motherboard that is ideal for embedded networking and storage systems. The latest features for this motherboard includes two Gigabit Ethernet, three M.2 M-Key/B-Key/E-Key connections, six COM ports (two RS232/433/485, four RS232), and a 48-bit dual channel LVDS connection.

The X11SWN-H/-E/-L/-C motherboard also supports a 12-24V wide range DC input power supply in order to meet various embedded applications.

Please note that this motherboard is intended to be installed and serviced by professional technicians only. For processor/memory updates, please refer to our website at <http://www.supermicro.com/products/>.

Manual Organization

Chapter 1 describes the features, specifications and performance of the motherboard, and provides detailed information on the processor.

Chapter 2 provides hardware installation instructions. Read this chapter when installing the processor, memory modules, and other hardware components into the system.

If you encounter any problems, see **Chapter 3**, which describes troubleshooting procedures for video, memory, and system setup stored in the CMOS.

Chapter 4 includes an introduction to the BIOS, and provides detailed information on running the CMOS Setup utility.

Appendix A provides BIOS Error Codes.

Appendix B lists software program installation instructions.

Appendix C lists standardized warning statements in various languages.

Appendix D provides UEFI BIOS Recovery instructions.

Contacting Supermicro

Headquarters

Address: Super Micro Computer, Inc.
980 Rock Ave.
San Jose, CA 95131 U.S.A.

Tel: +1 (408) 503-8000

Fax: +1 (408) 503-8008

Email: marketing@supermicro.com (General Information)
support@supermicro.com (Technical Support)

Website: www.supermicro.com

Europe

Address: Super Micro Computer B.V.
Het Sterrenbeeld 28, 5215 ML
's-Hertogenbosch, The Netherlands

Tel: +31 (0) 73-6400390

Fax: +31 (0) 73-6416525

Email: sales@supermicro.nl (General Information)
support@supermicro.nl (Technical Support)
rma@supermicro.nl (Customer Support)

Website: www.supermicro.nl

Asia-Pacific

Address: Super Micro Computer, Inc.
3F, No. 150, Jian 1st Rd.
Zhonghe Dist., New Taipei City 235
Taiwan (R.O.C)

Tel: +886-(2) 8226-3990

Fax: +886-(2) 8226-3992

Email: support@supermicro.com.tw

Website: www.supermicro.com.tw

Table of Contents

Chapter 1 Introduction

1.1 Checklist.....	9
Top Side Motherboard Image.....	11
Bottom Side Motherboard Image.....	11
Top Side Mechanical Layout.....	12
Bottom Side Mechanical Layout.....	12
Back Panel I/O with Heatsink (X11SWN-H/-E/-L/-C).....	13
Back Panel I/O without Heatsink (X11SWN-H/-E/-L/-C-WOHS).....	13
Back Panel I/O with Heat Spreader (optional).....	13
Quick Reference.....	14
Top Side Layout.....	14
Quick Reference (continued).....	15
Bottom Side Layout.....	15
Quick Reference Table.....	16
Motherboard Features.....	17
1.2 Processor Overview.....	21
1.3 Special Features.....	21
Recovery from AC Power Loss.....	21
1.4 ACPI Features.....	22
1.5 Power Supply.....	22
1.6 Serial Port.....	22

Chapter 2 Installation

2.1 Static-Sensitive Devices.....	23
Precautions.....	23
Unpacking.....	23
2.2 Motherboard Installation.....	24
Tools Needed.....	24
Location of Mounting Holes.....	24
Installing the Motherboard.....	25
2.3 Memory Support and Population.....	26
Memory Support.....	26

SO-DIMM Installation	27
SO-DIMM Removal	27
2.4 Rear I/O Ports	28
2.5 Front Control Panel	31
2.6 Connectors and Headers	34
Headers	35
2.7 Jumper Settings	48
How Jumpers Work	48
2.8 LED Indicators	52
Chapter 3 Troubleshooting	
3.1 Troubleshooting Procedures	53
Before Power On	53
No Power	53
No Video	53
Memory Errors	54
Losing the System's Setup Configuration	54
When the System Becomes Unstable	54
3.2 Technical Support Procedures	56
3.3 Frequently Asked Questions	58
3.4 Battery Removal and Installation	59
Battery Removal	59
Proper Battery Disposal	59
Battery Installation	59
3.5 Returning Merchandise for Service	60
Chapter 4 UEFI BIOS	
4.1 Introduction	61
Starting the Setup Utility	61
4.2 Main Setup	62
4.3 Advanced	64
4.4 Security	91
4.5 Boot	95
4.6 Save & Exit	97

Appendix A BIOS Codes

A.1 BIOS Error POST Codes.....99
A.2 Additional BIOS POST Codes.....99

Appendix B Software Installation

B.1 Installing Software Programs100
B.2 SuperDoctor® 5.....101

Appendix C Standardized Warning Statements

Battery Handling.....101
Product Disposal103

Appendix D UEFI BIOS Recovery

D.1 Overview.....104
D.2 Recovering the UEFI BIOS Image.....104
D.3 Recovering the Main BIOS Block with a USB Device105

Chapter 1

Introduction

Congratulations on purchasing your computer motherboard from an acknowledged leader in the industry. Supermicro boards are designed with the utmost attention to detail to provide you with the highest standards in quality and performance.

Please check that the following items have all been included with your motherboard. If anything listed here is damaged or missing, contact your retailer. The following items are included:

1.1 Checklist

Main Parts List (Single Retail Package)		
Description	Part Number	Quantity
Supermicro Motherboard (with Passive Heatsink)	X11SWN-H/-E/-L/-C	1
Audio Cable	CBL-OTHR-0986	1
COM Cable	CBL-CDAT-0665	1
SATA Power Cable	CBL-PWEX-1030	1
USB Cable	CBL-CUSB-0983	1
SATA Cable	CBL-SAST-0881	1
DC IN Power Cable	CBL-PWEX-1029	1
Quick Reference Guide	MNL-2217-QRG	1
Main Parts List (Bulk Package)		
Supermicro Motherboard with Passive Heatsink (-WOHS SKU does not include a heatsink)	X11SWN-H/-E/-L/-C X11SWN-H/-E/-L/-C-WOHS	1
SATA Cables	CBL-SAST-0881	1
SATA Power Cable	CBL-PWEX-1030	1
DC IN Power Cable	CBL-PWEX-1029	1
Optional Parts List		
Power Adapter	MCP-250-10117-0N	1
Heat Spreader	MCP-350-00008-0N	1
12V/5V SATA Power Cable	CBL-PWEX-1032	1

Important Links

For your system to work properly, please follow the links below to download all necessary drivers/utilities and the user's manual for your server.

- Supermicro product manuals: <http://www.supermicro.com/support/manuals/>
- Product drivers and utilities: <https://www.supermicro.com/wdl/driver/>
- Product safety info: http://www.supermicro.com/about/policies/safety_information.cfm
- A secure data deletion tool designed to fully erase all data from storage devices can be found at our website: https://www.supermicro.com/about/policies/disclaimer.cfm?url=/wdl/utility/Lot9_Secure_Data_Deletion_Utility/
- If you have any questions, please contact our support team at: support@supermicro.com

This manual may be periodically updated without notice. Please check the Supermicro website for possible updates to the manual revision level.

Figure 1-1. X11SWN Motherboard Image

Top Side Motherboard Image

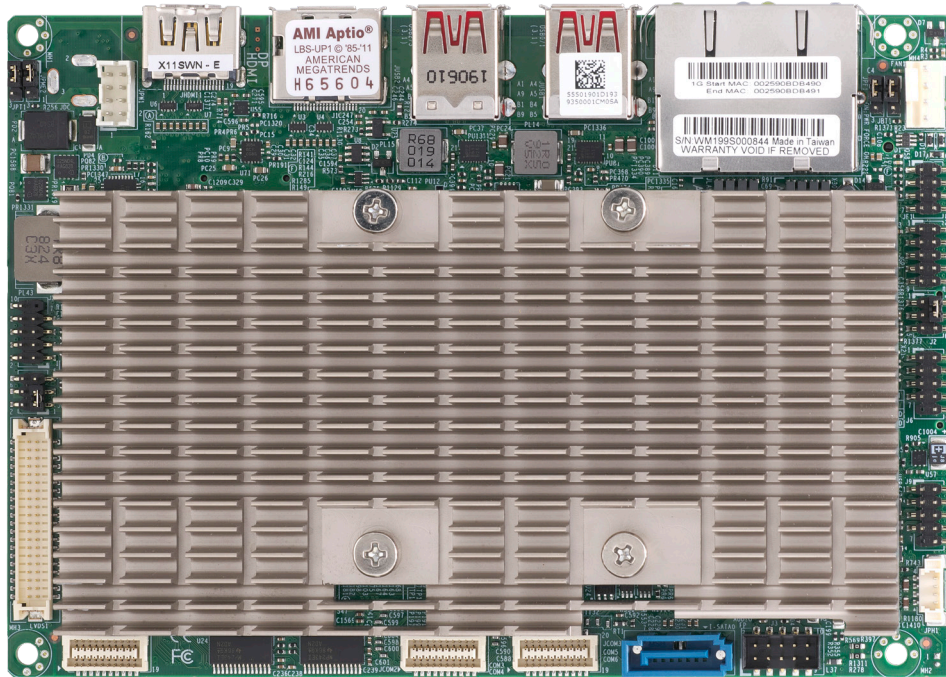

Bottom Side Motherboard Image

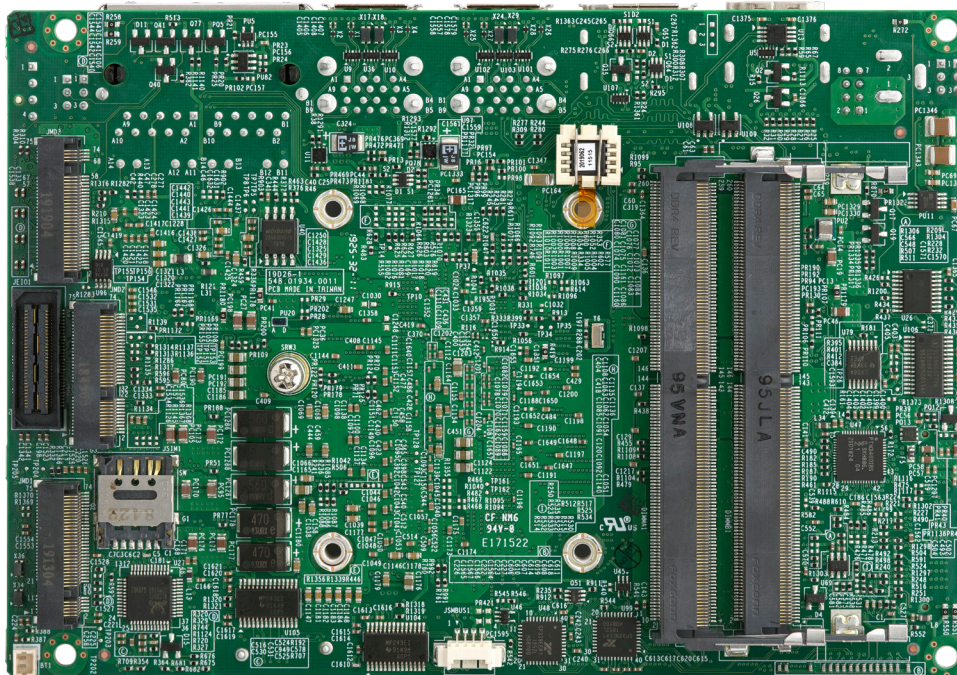
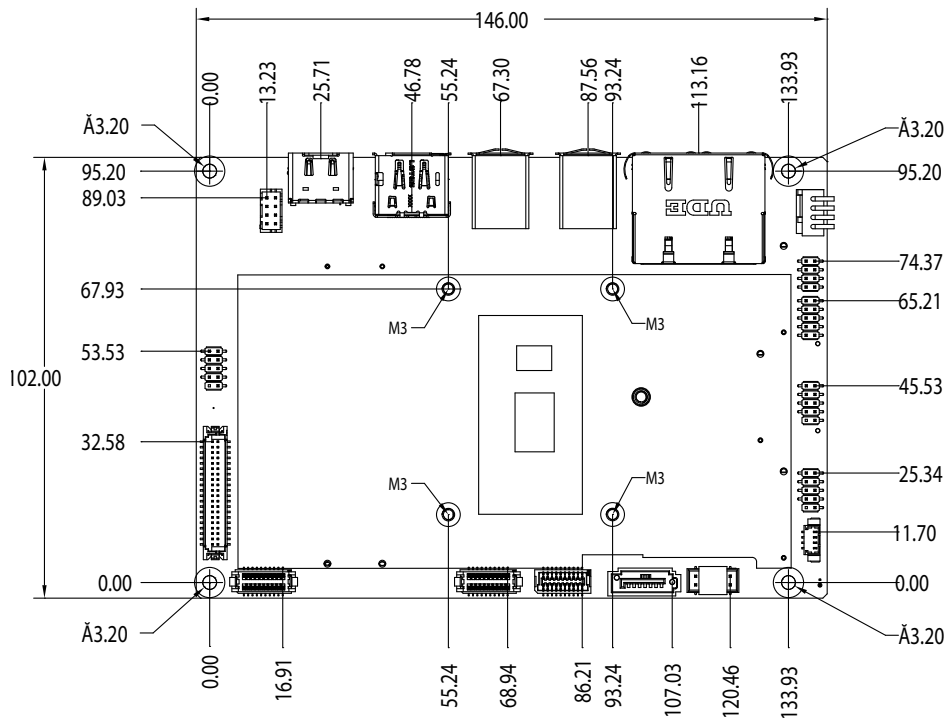

Figure 1-2. X11SWN Motherboard Mechanical Layouts
(not drawn to scale)

Top Side Mechanical Layout



Bottom Side Mechanical Layout

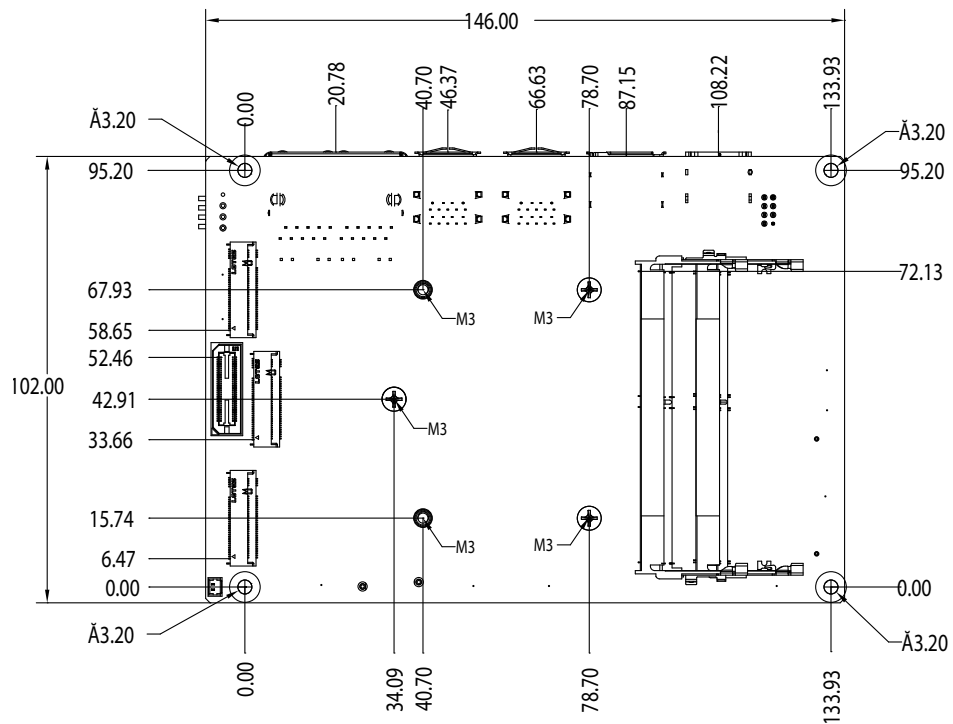
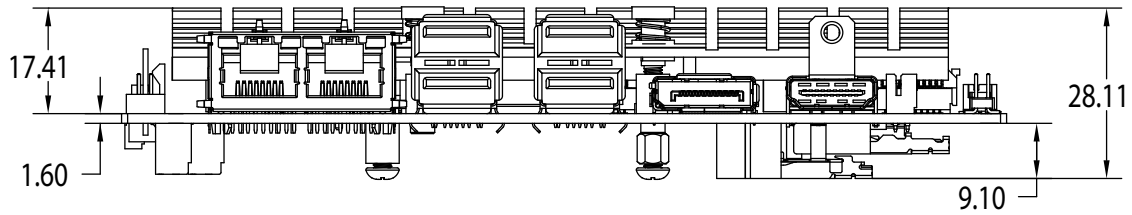
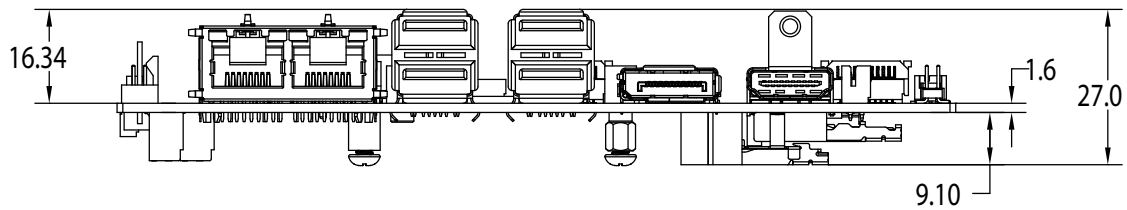

Figure 1-3. X11SWN Back Panel I/O Mechanical Layout
(not drawn to scale)

Back Panel I/O with Heatsink (X11SWN-H/-E/-L/-C)



Back Panel I/O without Heatsink (X11SWN-H/-E/-L/-C-WOHS)



Back Panel I/O with Heat Spreader (optional)

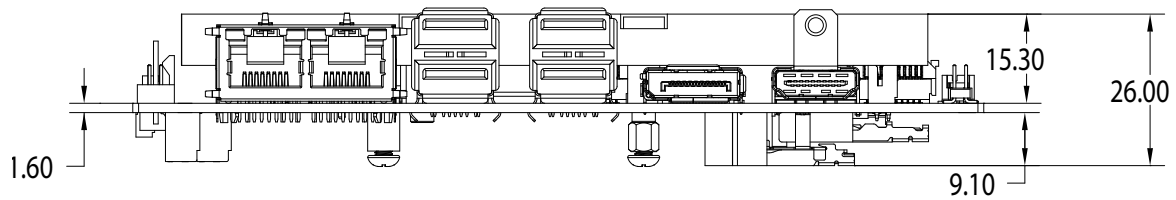

Quick Reference

Top Side Layout

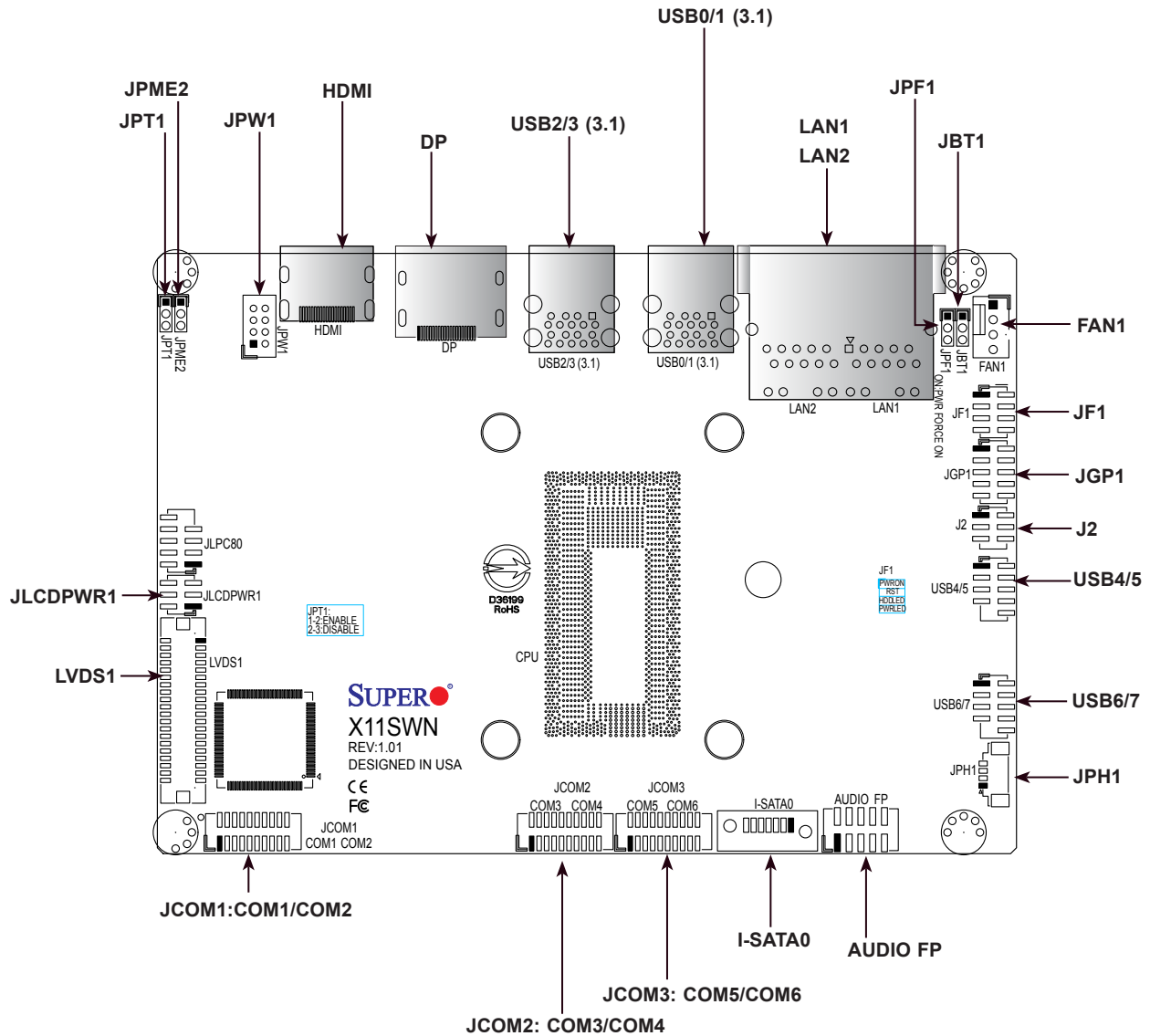

Notes:

- See Chapter 2 for detailed information on jumpers, I/O ports, and JF1 front panel connections.
- "■" indicates the location of Pin 1.

Quick Reference (continued)

Bottom Side Layout

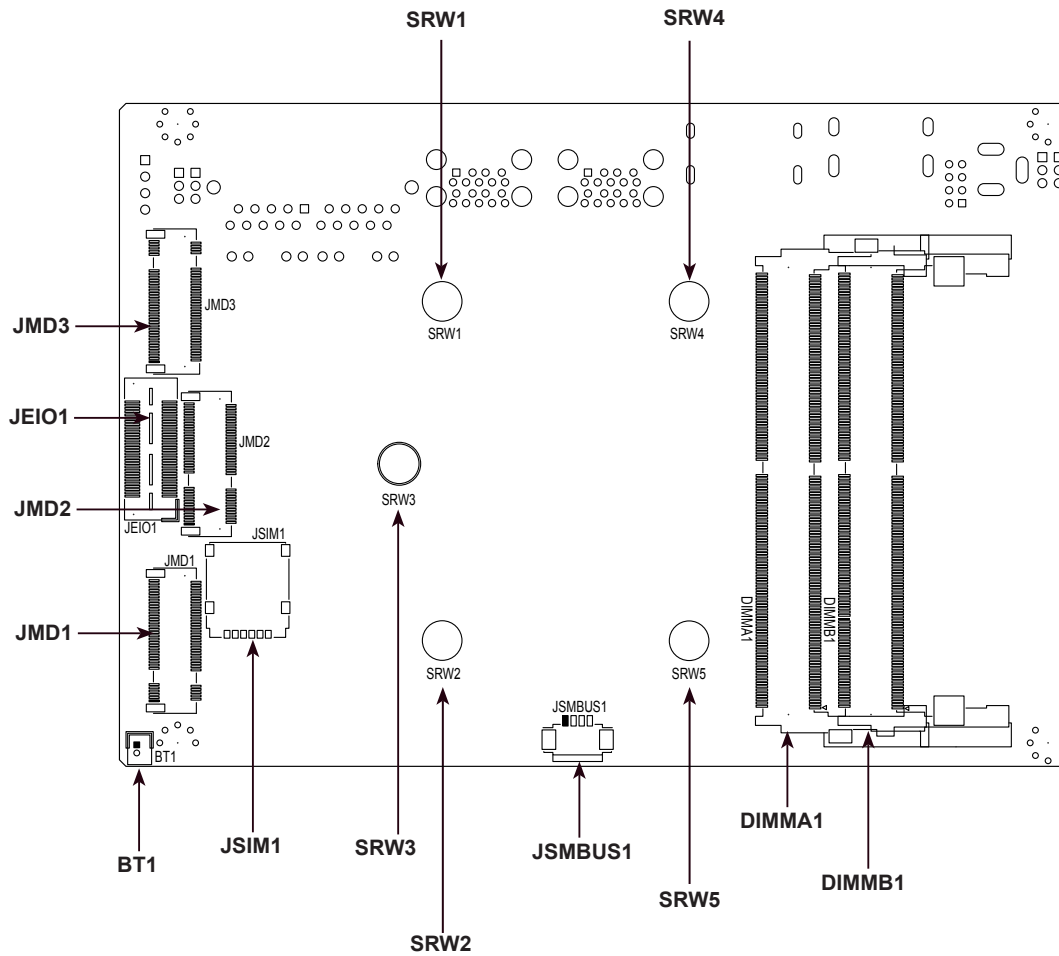

Quick Reference Table

Jumper	Description	Default Setting
JBT1	CMOS Clear	Pin 1-2* Normal Operation (Default) Pin 2-3 Clear CMOS
JLCDPWR1	LVDS Panel Power Source Selection	Pin 1-3* (3.3V) (Default) Pin 3-5 (5V) Pin 3-4 (12V)
JPF1	Power Force On	Pin 1-2* (Force Power ON) (Default) Pin 2-3 (Power Button ON)
JPME2	Manufacturing Mode Select	Pins 1-2 (Normal)
JPT1	TPM Enable/Disable	Pins 1-2* (Enabled) (Default) Pins 2-3 (Disabled)
J2	SIM Detection	Pins 2-4* (High Active) (Default) Pins 4-6 (Low Active)

Connector	Description
AUDIO FP	Front Panel Audio Header (Mic-In/Line-Out)
BT1	Onboard Battery Header (bottom side)
JCOM1	COM1/COM2 Headers (RS232/422/485)
JCOM2	COM3/COM4 Headers (RS232)
JCOM3	COM5/COM6 Headers (RS232)
DP	Dual-Mode Display Port (DP++)
FAN1	System Fan Header
HDMI	High Definition Multimedia Interface
I-SATA	SATA 6Gb/s (3.0) Port
JEIO1	Extended I/O (bottom side)
JF1	Front Control Panel Header
JGP1	General Purpose I/O Header
JMD1	M.2 B-Key 2242/3042/2280 (SATA 3.0/USB 3.0/USB 2.0 with Nano SIM) Slot (bottom side)
JMD2	M.2 E-Key 2230 (PCIe x1/USB2.0/CNVi) Slot (bottom side)
JMD3	M.2 M-Key 2242/2280 (PCIe x4/SATA) Slot (bottom side)
JPH1	4-pin HDD Power Output Connector
JPW1	8-pin +12-24V ATX Power Input Connector
JSIM1	Nano SIM Card Slot (bottom side)
JSMBUS1	System Management Bus Header (bottom side)
LAN1/LAN2	Gigabit Ethernet Ports
LVDS1	Low-Voltage Differential Signaling (LVDS) Connector
SRW1 - SRW5	M.2 Mounting Holes
USB0/1, USB2/3	Back Panel USB 3.1 Gen2 Ports
USB4/5, USB6/7	Front Accessible USB 2.0 Headers

Motherboard Features

Motherboard Features	
CPU	
<ul style="list-style-type: none"> • X11SWN-H / X11SWN-H-WOHS supports 8th Generation Intel® Core i7-8665UE Processor. • X11SWN-E / X11SWN-E-WOHS supports 8th Generation Intel Core i5-8365UE Processor. • X11SWN-L / X11SWN-L-WOHS supports 8th Generation Intel Core i3-8145UE Processor. • X11SWN-C / X11SWN-C-WOHS supports Intel Celeron Processor 4305UE Processor. 	
Memory	
<ul style="list-style-type: none"> • Supports up to 64GB of Non-ECC SO-DIMM (32GB per SO-DIMM) DDR4 memory with speeds of up to 2400MHz (2133MHz for X11SWN-C / X11SWN-C-WOHS). 	
DIMM Size	
<ul style="list-style-type: none"> • Up to 32GB 	
Expansion Slots	
<ul style="list-style-type: none"> • One M.2 B-Key 3042/2242/2280 (SATA 6Gb/s/ USB3 / USB2) with Nano SIM Holder • One M.2 E-Key 2230 (PCIe x1 / USB2 / CNVi) • One M.2 M-Key 2242/3042 (SATA 6Gb/s / PCIe x4) 	
Network	
<ul style="list-style-type: none"> • Single LAN with Intel Ethernet Controller i210IT with RJ45 • Single LAN with Intel PHY i219LM LAN controller with RJ45 	
Graphics Core	
<ul style="list-style-type: none"> • Intel UHD Graphics 620 <p>Features: OpenGL 4.5, DirectX 12, OpenCL 2.1, Intel Built-In Visuals, Intel Quick Sync Video, PlayReady 3, SGX-CP. Hardware Decode: AVC/H.264, MPEG2, VC1, MJPEG, HEVC/H.265 8/10 bit, VP8, VP9, VP9 10bit. Hardware Encode: AVC/H.264, MPEG2, MJPEG, HEVC/H.265 8/10 bit, VP8, VP9.</p>	
I/O Devices	
<ul style="list-style-type: none"> • SATA 3.0 	<ul style="list-style-type: none"> • One SATA 3 (6Gb/s) Ports
<ul style="list-style-type: none"> • Video 	<ul style="list-style-type: none"> • One DP++ (Dual-Mode DisplayPort) port (max. resolution up to 4096x2304 at 60Hz). • One Dual channel 48-bit LVDS (max. resolution up to 1920x1200 at 60Hz). • One HDMI 1.4 port (max. resolution up to 4096x2160 at 30Hz).
<ul style="list-style-type: none"> • COM Headers 	<ul style="list-style-type: none"> • Six COM Headers (JCOM1 supports two RS232/433/485, JCOM2/JCOM3 supports two RS232)
<ul style="list-style-type: none"> • TPM 	<ul style="list-style-type: none"> • One Onboard TPM 2.0 Chip
<ul style="list-style-type: none"> • Others 	<ul style="list-style-type: none"> • One HD Audio header Mic-in/Headphone-out (Audio only support at 0~60C) • One 8-bit GPIO header • One SMBus header • One System Fan



Note: The table above is continued on the next page.

Motherboard Features	
Peripheral Devices	
<ul style="list-style-type: none"> • Four USB 2.0 Headers (Four via headers, USB4/5, USB6/7) • Four USB 3.1 Gen 2 Ports (Four Rear Type A, USB0/1, USB2/3) 	
BIOS	
<ul style="list-style-type: none"> • 256Mb SPI MX25L25673GM2I-08G • Plug and Play (PnP), ACPI 6.1, BIOS rescue hot-key, SMBIOS 2.8/3.1, PCI F/W 3.0, RTC Wakeup, UEFI 2.7 	
Power Management	
<ul style="list-style-type: none"> • ACPI power management • Power button override mechanism • Power-on mode for AC power recovery 	
System Health Monitoring	
<ul style="list-style-type: none"> • Onboard voltage monitors for CPU cores, +1.8V, +3.3V, +5V, +/-12V, +3.3V Stby, +5V Stby, VBAT, HT, Memory, CPU temperature, and system temperature. • CPU Thermal Trip support 	
Fan Control	
<ul style="list-style-type: none"> • Fan status monitoring with firmware • Multi-speed fan control via SIO 	
System Management	
<ul style="list-style-type: none"> • AMT, vPro • SuperDoctor® 5, Watch Dog 	
LED Indicators	
<ul style="list-style-type: none"> • Power/Suspend State Indicator LED • LAN Activity LED 	
Other	
<ul style="list-style-type: none"> • RoHS 	
Mechanical Specification	
<ul style="list-style-type: none"> • Proprietary form factor (4" x 5.75") (102 mm x 146 mm) • Total Height: X11SWN-H/-E/-L/-C 28.11mm, X11SWN-H/-E/-L/-C-WOHS 27.00 mm 	
Environment	
<ul style="list-style-type: none"> • Operating Temperature Range: X11SWN-H/-E/-L/-C supports 0°C ~ 60°C (32°F ~ 140°F), X11SWN-H/-E/-L/-C-WOHS supports 0°C ~ 70°C (32°F ~ 158°F) • Non-Operating Temperature Range: -40°C ~ 85°C (-40°F ~ 185°F) • Operating Relative Humidity Range: 8% ~ 90% (non-condensing) • Non-Operating Relative Humidity Range: 10% ~ 95% (non-condensing) 	

 **Note 1:** The CPU maximum thermal design power (TDP) is subject to chassis and heatsink cooling restrictions. For proper thermal management, please check the chassis and heatsink specifications for proper CPU TDP sizing.

Figure 1-4.
Chipset Block Diagram



Note: This is a general block diagram and may not exactly represent the features on your motherboard. See the previous pages for the actual specifications of your motherboard.

**Figure 1-5.
X11SWN Model Variation Table**

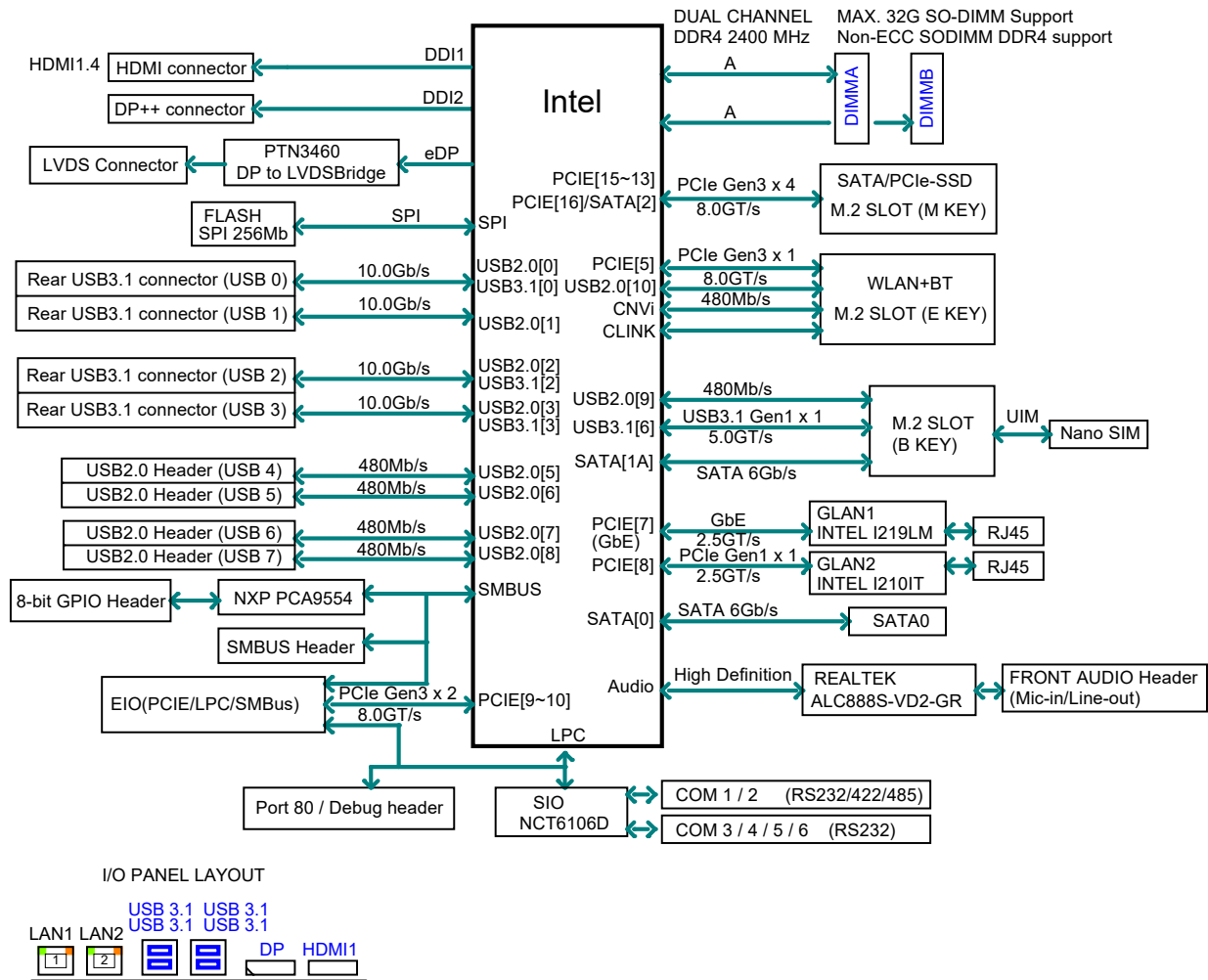
Model	CPU	Base Freq	Turbo Freq	CPU TDP	GbE	DP++	HDMI	LVDS	RS-232	RS-232/422/485
X11SWN-H	i7-8665UE	1.7	4.4	15W	2	1	1	48-bit	4	2
X11SWN-E	i5-8365UE	1.6	4.1	15W	2	1	1	48-bit	4	2
X11SWN-L	i3-8145UE	2.2	3.9	15W	2	1	1	48-bit	4	2
X11SWN-C	Celeron 4305UE	2	2	15W	2	1	1	48-bit	4	2
X11SWN-H- WOHS	i7-8665UE	1.7	4.4	15W	2	1	1	48-bit	4	2
X11SWN-E- WOHS	i5-8365UE	1.6	4.1	15W	2	1	1	48-bit	4	2
X11SWN-L- WOHS	i3-8145UE	2.2	3.9	15W	2	1	1	48-bit	4	2
X11SWN-C- WOHS	Celeron 4305UE	2	2	15W	2	1	1	48-bit	4	2

Model	USB3.1 Gen2	USB2.0	GPIO	Audio	TPM	vPro	Temp.	Heatsink
X11SWN-H	4	4	8-bit	Yes	2.0	Yes	0-60C	Passsive
X11SWN-E	4	4	8-bit	Yes	2.0	Yes	0-60C	Passsive
X11SWN-L	4	4	8-bit	Yes	2.0	No	0-60C	Passsive
X11SWN-C	4	4	8-bit	Yes	2.0	No	0-60C	Passsive
X11SWN-H- WOHS	4	4	8-bit	Yes	2.0	Yes	0-70C	N/A
X11SWN-E- WOHS	4	4	8-bit	Yes	2.0	Yes	0-70C	N/A
X11SWN-L- WOHS	4	4	8-bit	Yes	2.0	No	0-70C	N/A
X11SWN-C- WOHS	4	4	8-bit	Yes	2.0	No	0-70C	N/A

1.2 Processor Overview

The 8th Gen. Intel Core processor family, with up to four cores and low TDP (15W, TDP down to 12.5W) of power, offers performance, reliability, and high intelligence. As a low-power system-on-a-chip motherboard, the X11SWN-H/-E/-L/-C is optimized for a variety of workloads that requires high compute power in a compact form-factor.

- Intel vPro™
- Intel Hyper-Threading Technology
- Intel Turbo Boost Technology
- Advanced Configuration and Power Interface Specification version 6.1
- Intel Virtualization Technology (VT-x)
- Intel Virtualization Technology for Directed I/O (VT-d)
- Intel VT-x with Extended Page Tables (EPT)
- Intel Rapid Storage Technology
- System Management Bus (SMBus) Specification Version 2.0
- Intel Trusted Execution Technology (Intel TXT)
- Intel AES New Instructions (Intel AES-NI)
- Intel Software Guard Extensions (Intel SGX)

1.3 Special Features

This section describes the health monitoring features of the X11SWN-H/-E/-L/-C motherboard. The motherboard has an onboard System Hardware Monitor chip that supports system health monitoring.

Recovery from AC Power Loss

The Basic I/O System (BIOS) provides a setting that determines how the system will respond when AC power is lost and then restored to the system. You can choose for the system to remain powered off (in which case you must press the power switch to turn it back on), or for it to automatically return to the power-on state. See the Advanced BIOS Setup section for this setting. The default setting is **Last State**.

1.4 ACPI Features

The Advanced Configuration and Power Interface (ACPI) specification defines a flexible and abstract hardware interface that provides a standard way to integrate power management features throughout a computer system, including its hardware, operating system and application software. This enables the system to automatically turn on and off peripherals such as CD-ROMs, network cards, hard disk drives and printers.

In addition to enabling operating system-directed power management, ACPI also provides a generic system event mechanism for Plug and Play, and an operating system-independent interface for configuration control. ACPI leverages the Plug and Play BIOS data structures, while providing a processor architecture-independent implementation that is compatible with Windows operating systems.

1.5 Power Supply

As with all computer products, a stable power source is necessary for proper and reliable operation. It is even more important for processors that have high CPU clock rates. In areas where noisy power transmission is present, you may choose to install a line filter to shield the computer from noise. It is recommended that you also install a power surge protector to help avoid problems caused by power surges. It is strongly recommended that you use a high quality power supply that meets ATX power supply Specification 2.02 or above. It must also be SSI compliant. For more information, please refer to the website at <http://www.ssiforum.org/>.

The X11SWN-H/-E/-L/-C motherboard supports an 8-pin 12-24V DC input power supply at JPW1 for embedded applications. The 12-24V DC input is limited to 10A (12V) to 5A (24V) by design. It provides up to 120W power input to the motherboard. Keep the onboard power usage within the power limits specified above. Over current power usage may cause damage to the motherboard.

1.6 Serial Port

The X11SWN-H/-E/-L/-C motherboard supports six serial communication connections. They can be used for input/output. The UART provides legacy speeds with a baud rate of up to 115.2 Kbps as well as an advanced speed with baud rates of 250 K, 500 K, or 1 Mb/s, which support high-speed serial communication devices.

Chapter 2

Installation

2.1 Static-Sensitive Devices

Electrostatic Discharge (ESD) can damage electronic components. To prevent damage to your motherboard, it is important to handle it very carefully. The following measures are generally sufficient to protect your equipment from ESD.

Precautions

- Use a grounded wrist strap designed to prevent static discharge.
- Touch a grounded metal object before removing the board from the antistatic bag.
- Handle the board by its edges only; do not touch its components, peripheral chips, memory modules or gold contacts.
- When handling chips or modules, avoid touching their pins.
- Put the motherboard and peripherals back into their antistatic bags when not in use.
- For grounding purposes, make sure your computer chassis provides excellent conductivity between the power supply, the case, the mounting fasteners and the motherboard.
- Use only the correct type of onboard CMOS battery. Do not install the onboard battery upside down to avoid possible explosion.

Unpacking

The motherboard is shipped in antistatic packaging to avoid static damage. When unpacking the motherboard, make sure that the person handling it is static protected.

Installing the Motherboard

1. Locate the mounting holes on the motherboard. See the previous page for the location.

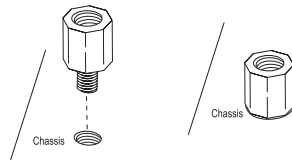

2. Locate the matching mounting holes on the chassis. Align the mounting holes on the motherboard against the mounting holes on the chassis.

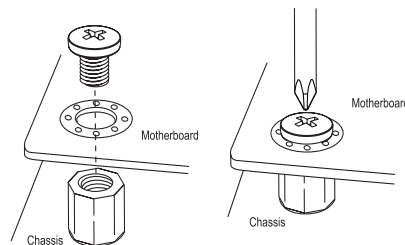

3. Install standoffs in the chassis as needed.
4. Install the motherboard into the chassis carefully to avoid damaging other motherboard components.
5. Using the Phillips screwdriver, insert a Phillips head #6 screw into a mounting hole on the motherboard and its matching mounting hole on the chassis.
6. Repeat Step 5 to insert #6 screws into all mounting holes.
7. Make sure that the motherboard is securely placed in the chassis.

 **Note:** Images displayed are for illustration only. Your chassis or components might look different from those shown in this manual.

2.3 Memory Support and Population



Important: Exercise extreme care when installing or removing DIMM modules to prevent any possible damage.

Memory Support

The X11SWN-H/-E/-L/-C motherboard supports up to 64GB of SO-DIMM (32GB per DIMM) in two memory slots. Populating these DIMM slots with memory modules of the same type and size will result in interleaved memory, which will improve memory performance.

Bottom Layout

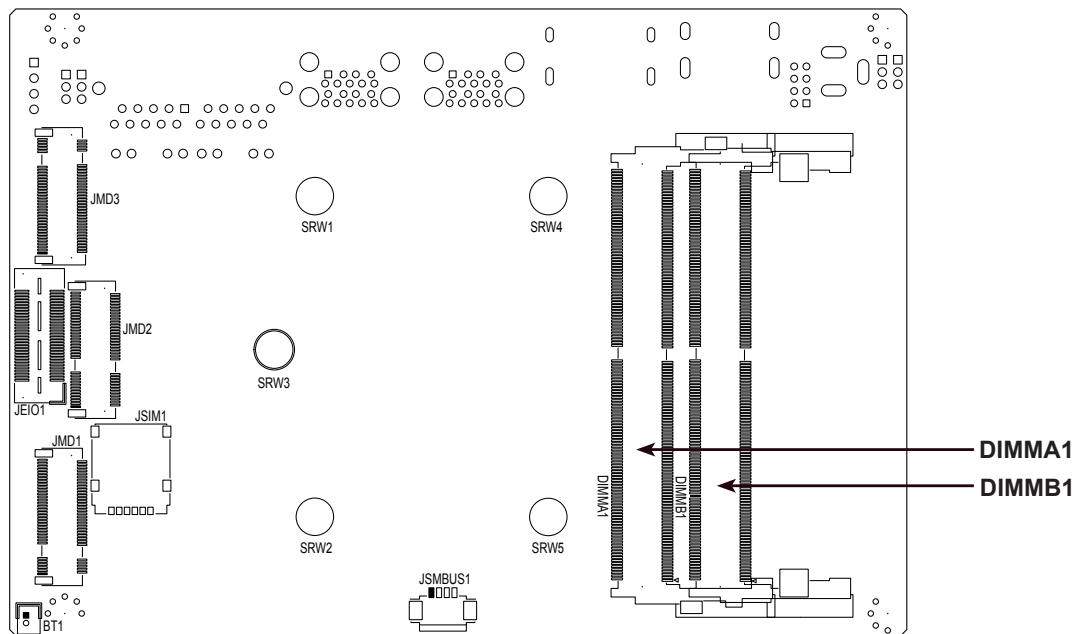

SO-DIMM Installation

1. Position the SO-DIMM module's bottom key so it aligns with the receptive point on the slot.

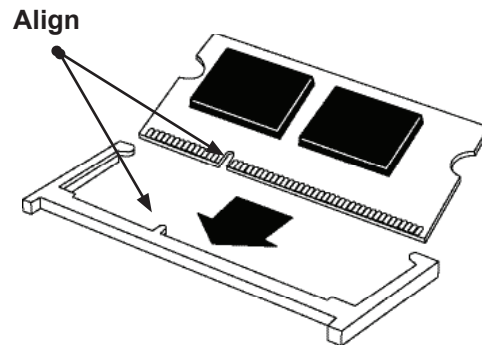

2. Insert the SO-DIMM module vertically at about a 45 degree angle. Press down until the module locks into place.

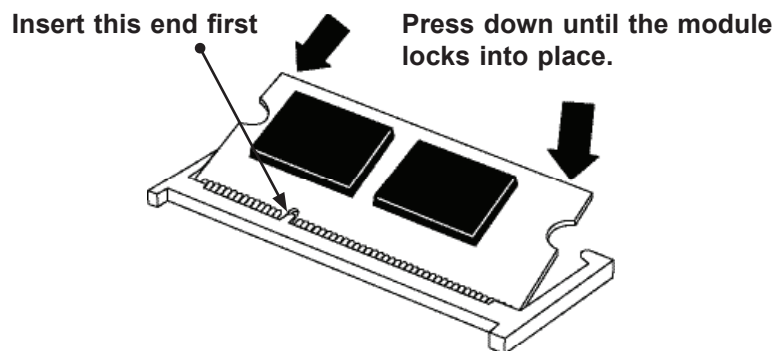

3. The side clips will automatically secure the SO-DIMM module, locking it into place.

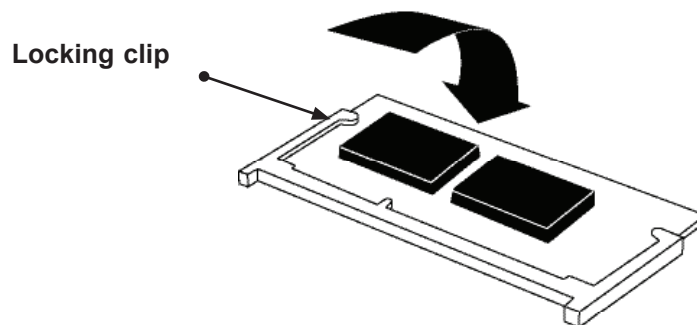

SO-DIMM Removal

1. Push the side clips at the end of the slot to release the SO-DIMM module. Pull the SO-DIMM module up to remove it from the slot.

2.4 Rear I/O Ports

See the figure below for the locations and descriptions of the various I/O ports on the rear of the motherboard.

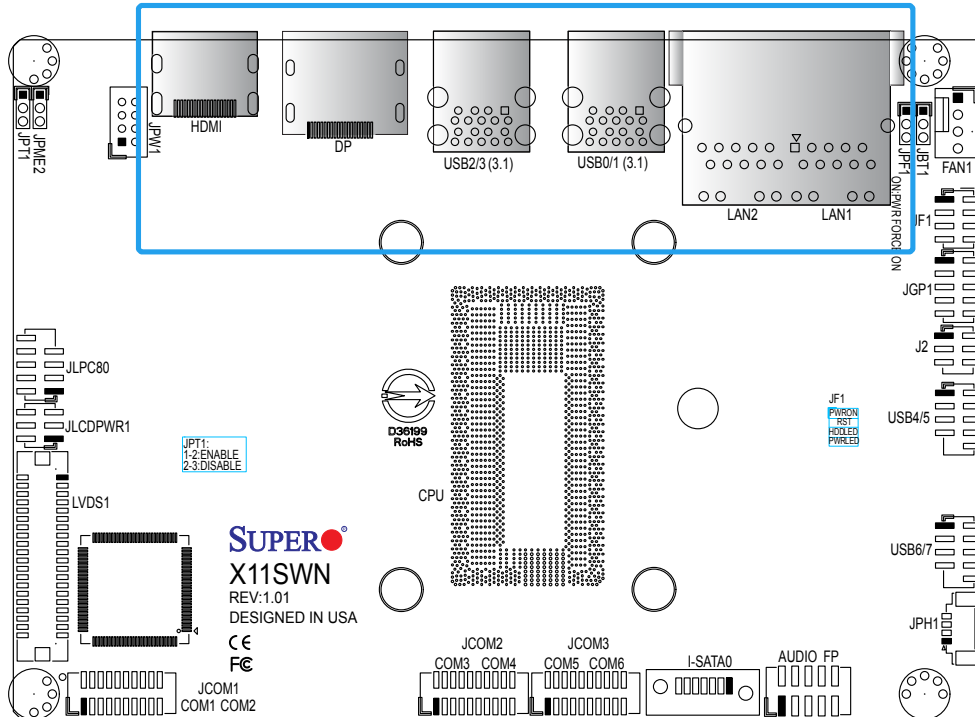
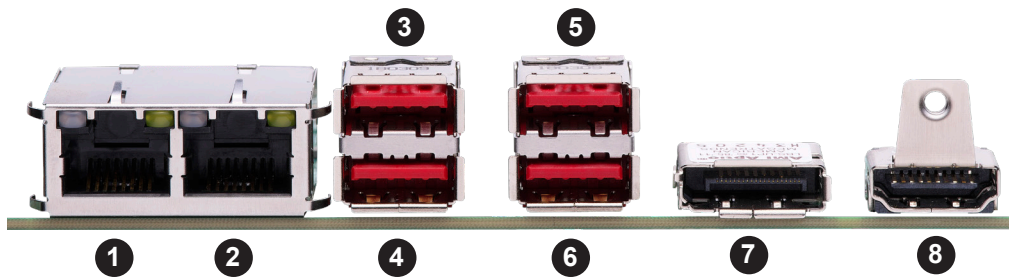

Figure 2-1. I/O Port Definitions



#	Description	#	Description
1.	LAN1	5.	USB2 (USB3.1 Gen 2)
2.	LAN2	6.	USB3 (USB3.1 Gen 2)
3.	USB1 (USB3.1 Gen 2)	7.	DP++
4.	USB0 (USB3.1 Gen 2)	8.	HDMI

LAN Ports

Two LAN ports (LAN1/LAN2) are located on the I/O back panel. These ports accept RJ45 type cables. Please refer to the LED Indicator section for LAN LED information. Refer to the table below for pin definitions.

LAN Port Pin Definition			
Pin#	Definition	Pin#	Definition
1	TD1+	11	YEL-
2	TD1-	12	YEL+
3	TD2+	13	GRN-/ORG+
4	TD2-	14	GRN+/ORG-
5	CT_VCC	15	
6	CT_VCC	16	
7	TD3+	17	
8	TD3-	18	
9	TD4+	19	
10	TD4-	20	

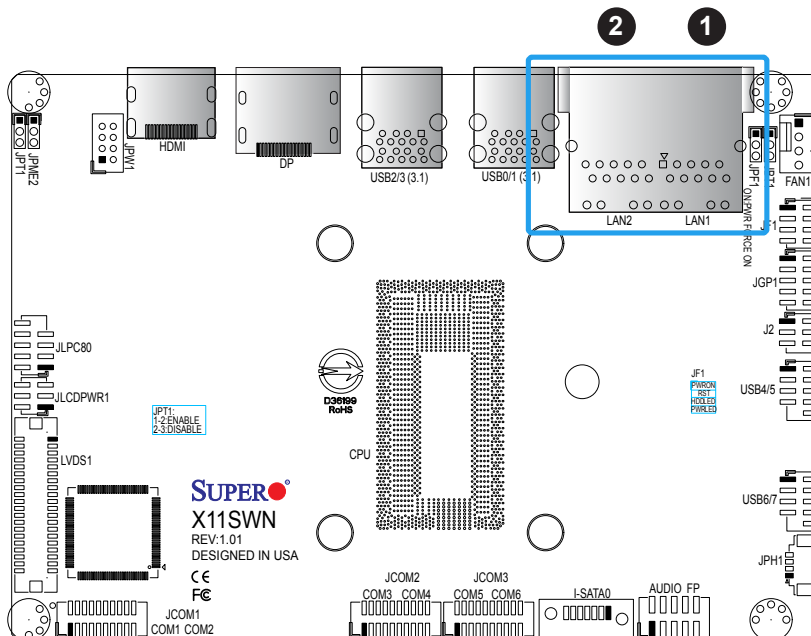

1. LAN1
2. LAN2

HDMI Port

The HDMI (High-Definition Multimedia Interface) port is used to display both high definition video and digital sound through an HDMI-capable display, using the same cable.

DP++

DisplayPort, developed by the VESA consortium, delivers digital display and fast refresh rate. It can connect to virtually any display device using a DisplayPort adapter for devices such as VGA, DVI or HDMI.

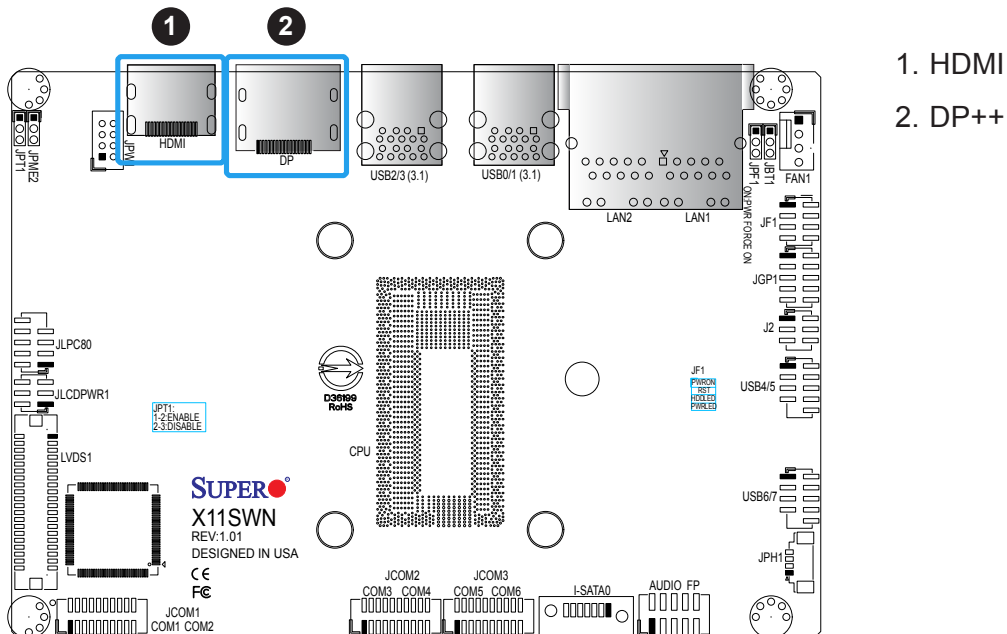

2.5 Front Control Panel

JF1 contains header pins for various buttons and indicators that are normally located on a control panel at the front of the chassis. These connectors are designed specifically for use with Supermicro chassis. Refer to the figure below for the descriptions of the front control panel buttons and LED indicators.

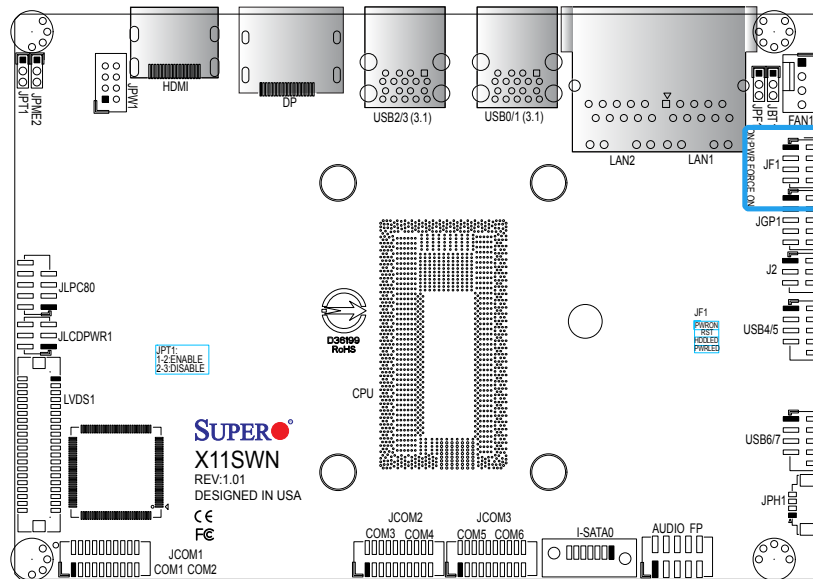
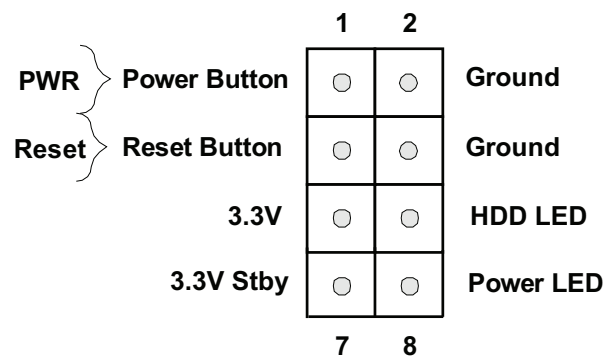

Figure 2-2. JF1 Header Definitions



Power Button

The Power Button connection is located on pins 1 and 2 of JF1. Momentarily contacting both pins will power on/off the system. This button can also be configured to function as a suspend button (with a setting in the BIOS - see Chapter 4). To turn off the power in the suspend mode, press the button for at least four seconds. Refer to the table below for pin definitions.

Power Button Pin Definitions (JF1)	
Pins	Definition
1	Signal
2	Ground

Reset Button

The Reset Button connection is located on pins 3 and 4 of JF1. Attach it to a hardware reset switch on the computer case to reset the system. Refer to the table below for pin definitions.

Reset Button Pin Definitions (JF1)	
Pins	Definition
3	Reset
4	Ground

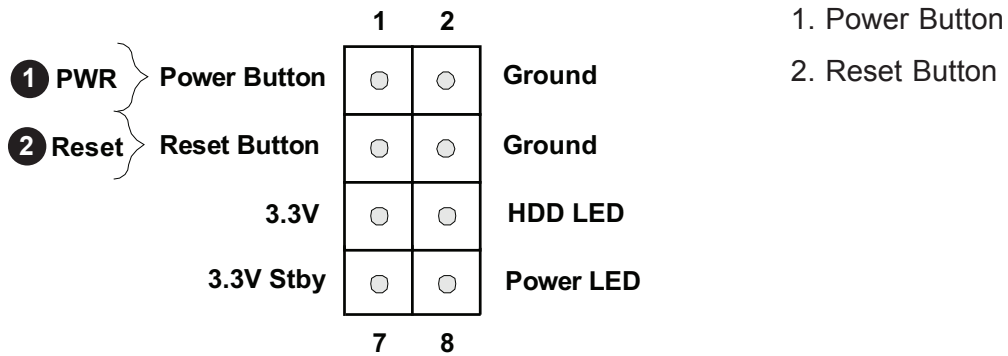

HDD LED

The HDD LED connection is located on pins 5 and 6 of JF1. Attach a cable here to show hard drive activity status. Refer to the table below for pin definitions.

HDD LED Pin Definitions (JF1)	
Pins	Definition
5	+3.3V
6	HDD LED

Power LED

The Power LED connection is located on pins 7 and 8 of JF1. Refer to the table below for pin definitions.

Power LED Pin Definitions (JF1)	
Pins	Definition
7	+3.3V Stby
8	PWR LED

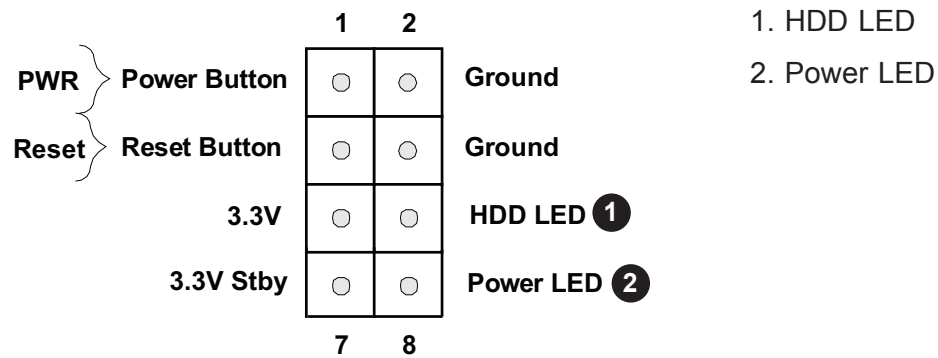

2.6 Connectors and Headers

Power Connectors

JPW1 is the 12-24V DC power connector that provides power to the motherboard. JPH1 is a 4-pin HDD power connector that provides power to the hard disk drives.

8-pin 12-24V Power Pin Definitions	
Pins	Definition
1 - 4	+12-24V
5 - 8	Ground

4-pin HDD Power Pin Definitions	
Pins	Definition
1	12V
2-3	Ground
4	5V

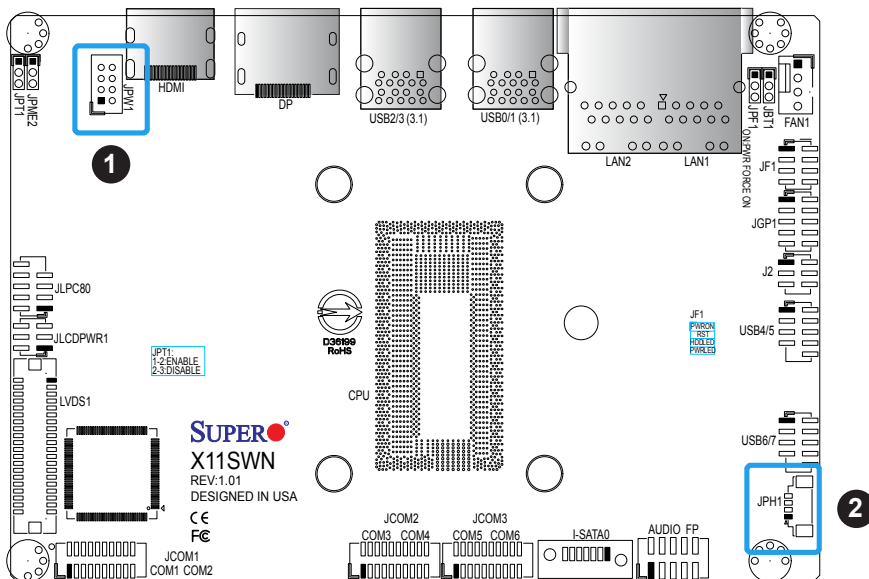

1. 8-Pin 12-24V Power
2. 4-pin HDD Power

Headers

Fan Header

There is one fan header with 4-pins on the motherboard. Pins 1-3 are backward compatible with traditional 3-pin fans. The onboard fan speeds are controlled by Thermal Management (via Hardware Monitoring) in the BIOS. When using Thermal Management setting, please use all 3-pin fans or all 4-pin fans.

Fan Header Pin Definitions	
Pin#	Definition
1	Ground (Black)
2	+12V (Red)
3	Tachometer
4	PWM Control

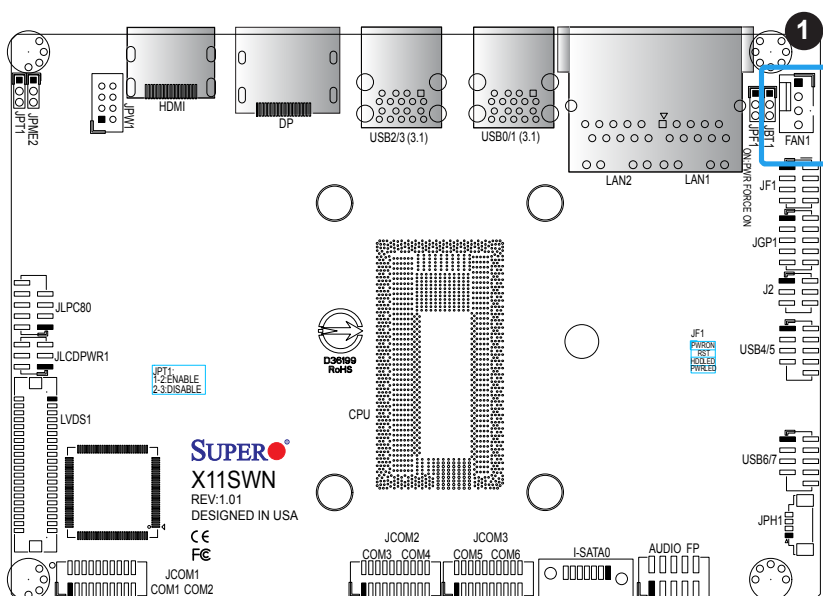

1. FAN1

COM Header

The motherboard has three COM headers that provide six COM connections. COM1/2 from JCOM1 supports RS232/422/485. COM3/4/5/6 from JCOM2/3 supports RS232 only. The manufacturer of the header is ACES Electronics, MPN 50419-02001. The mapping plug header for cable assembly is 50420-020HKH0-001. Below are the pin definition tables for the onboard header and D-SUB of CBL-CDAT-0665. Refer to the corresponding table based on design requirements. COM port pin definition tables are on the next page.

COM Port Pin Definitions (D-SUB from CBL-CDAT-0665 for JCOM1)			
Pin#	RS-232	RS-422/485 Full Duplex	RS-485 Half Duplex
1	SP_DCD1	TX-1	Data-1
2	SP_RXD1	TX+1	Data+1
3	SP_TXD1	RX+1	
4	SP_DTR1	RX-1	
5	GND		
6	SP_DSR1		
7	SP_RTS1		
8	SP_CTS1		
9	SP_RI1		
10	NC		
11	SP_DCD2	TX-2	Data-2
12	SP_RXD2	TX+2	Data+2
13	SP_TXD2	RX+2	
14	SP_DTR2	RX-2	
15	GND		
16	SP_DSR2		
17	SP_RTS2		
18	SP_CTS2		
19	SP_RI2		
20	NC		

COM Port Pin Definitions (D-SUB from CBL-CDAT-0665 for JCOM2)			
Pin#	RS-232	Pin#	RS-232
1	SP_DCD3	11	SP_DCD4
2	SP_RXD3	12	SP_RXD4
3	SP_TXD3	13	SP_TXD4
4	SP_DTR3	14	SP_DTR4
5	GND	15	GND
6	SP_DSR3	16	SP_DSR4
7	SP_RTS3	17	SP_RTS4
8	SP_CTS3	18	SP_CTS4
9	SP_RI3	19	SP_RI4
10	NC	20	NC

COM Port Pin Definitions (D-SUB from CBL-CDAT-0665 for JCOM3)			
Pin#	RS-232	Pin#	RS-232
1	SP_DCD5	11	SP_DCD6
2	SP_RXD5	12	SP_RXD6
3	SP_TXD5	13	SP_TXD6
4	SP_DTR5	14	SP_DTR6
5	GND	15	GND
6	SP_DSR5	16	SP_DSR6
7	SP_RTS5	17	SP_RTS6
8	SP_CTS5	18	SP_CTS6
9	SP_RI5	19	SP_RI6
10	NC	20	NC

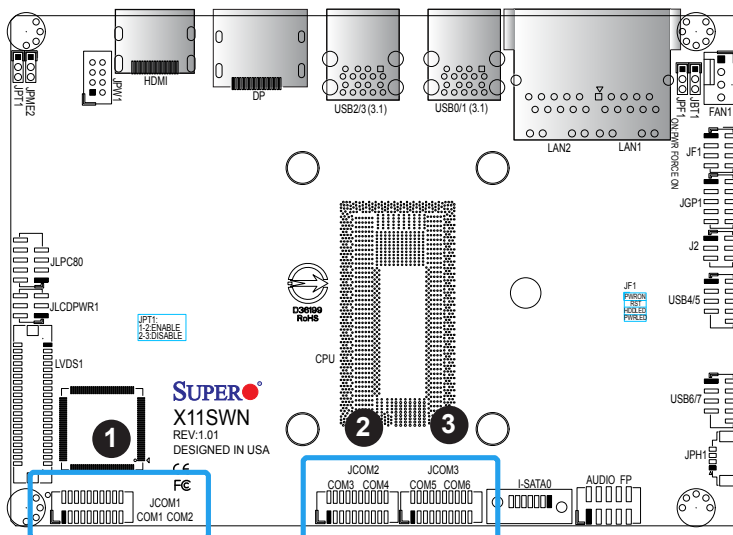

1. JCOM1: COM1/2
2. JCOM2: COM3/4
3. JCOM3: COM5/6

COM Pin Definitions (JCOM1)			
Pin#	RS-232	RS-422/485 Full Duplex	RS-485 Half Duplex
1	SP_DCD1	TX-1	Data-1
2	SP_DSR1		
3	SP_RXD1	TX+1	Data+1
4	SP_RTS1		
5	SP_TXD1	RX+1	
6	SP_CTS1		
7	SP_DTR1	RX-1	
8	SP_RI1		
9	GND		
10	NC		
11	SP_DCD2	TX-2	Data-2
12	SP_DSR2		
13	SP_RXD2	TX+2	Data+2
14	SP_RTS2		
15	SP_TXD2	RX+2	
16	SP_CTS2		
17	SP_DTR2	RX-2	
18	SP_RI2		
19	GND		
20	NC		

COM Pin Definitions (JCOM2)	
Pin#	RS-232
1	SP_DCD3
2	SP_DSR3
3	SP_RXD3
4	SP_RTS3
5	SP_TXD3
6	SP_CTS3
7	SP_DTR3
8	SP_RI3
9	GND
10	NC
11	SP_DCD4
12	SP_DSR4
13	SP_RXD4
14	SP_RTS4
15	SP_TXD4
16	SP_CTS4
17	SP_DTR4
18	SP_RI4
19	GND
20	NC

COM Pin Definitions (JCOM3)	
Pin#	RS-232
1	SP_DCD5
2	SP_DSR5
3	SP_RXD5
4	SP_RTS5
5	SP_TXD5
6	SP_CTS5
7	SP_DTR5
8	SP_RI5
9	GND
10	NC
11	SP_DCD6
12	SP_DSR6
13	SP_RXD6
14	SP_RTS6
15	SP_TXD6
16	SP_CTS6
17	SP_DTR6
18	SP_RI6
19	GND
20	NC

Front Panel Audio Header

A 10-pin front panel audio header located on the motherboard allows you to use the onboard sound for audio playback. Connect an audio cable to this header to use this feature. Refer to the table below for pin definitions.

Audio Header Pin Definitions			
Pin#	Definition	Pin#	Definition
1	Microphone_Left	2	Audio_Ground
3	Microphone_Right	4	Audio_Detect
5	Line_Out_Right	6	Ground
7	Jack_Detect	8	Key
9	Line_Out_Left	10	Ground

SATA Ports

The X11SWN-H/-E/-L/-C motherboard has one I-SATA 3.0 ports. Refer to the tables below for pin definitions. SATA ports provide serial-link signal connections, which are faster than the connections of Parallel ATA.

SATA 3.0 Port Pin Definitions	
Pin#	Signal
1	Ground
2	SATA_TXP
3	SATA_TXN
4	Ground
5	SATA_RXN
6	SATA_RXP
7	Ground

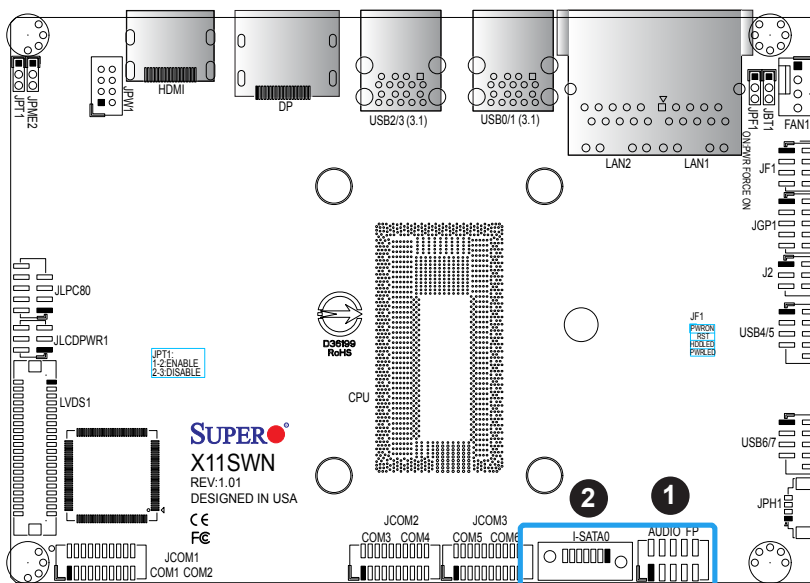

1. Audio Header
2. I-SATA 3.0

M.2 Slots

The X11SWN-H/-E/-L/-C motherboard has three M.2 slots. M.2 was formerly known as Next Generation Form Factor (NGFF). M.2 allows for a variety of card sizes, increased functionality, and spatial efficiency. The M.2 slot at JMD1 supports M.2 B-Key SATA 3.1/USB 3.0/USB 2.0 modules with Nano SIM in a 2242/3042/2280 form factor, whereas the M.2 slot at JMD2 supports M.2 E-Key PCIe x1/USB2.0/CNVi modules in a 2230 form factor. The M.2 slot at JMD3 supports M.2 M-Key PCIe x4/SATA modules in a 2242/2280 form factor. Refer to the tables below for pin definitions.

 **Note:** The tables are continued on the next page.

1. JMD1 - M.2 B-Key
2. JMD2 - M.2 E-Key
3. JMD3 - M.2 M-Key

Bottom Side Layout

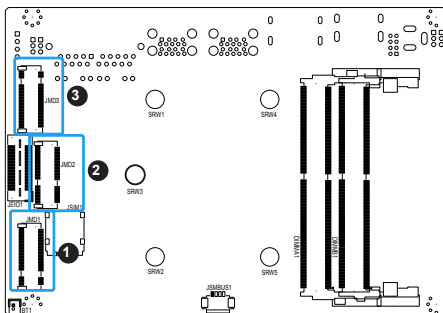

M.2 Pin Definition (JMD1)			
Pin#	Definition	Pin#	Definition
1	N/C	2	P3V3SB
3	GND	4	P3V3SB
5	GND	6	FULL_CARD_POWER_OFF#(PU TO P1V8SB only)
7	USB_D+	8	W_DISABLE1#(PU TO P3V3SB only)
9	USB_D-	10	N/C
11	GND	12-19	KEY B
20-22	N/C	23	WAKE_ON_WWAN#(PU TO P1V8SB only)
24-25	N/C	26	W_DISABLE2#(PU TO P1V8SB only)
27	GND	28	N/C
29	USB3.0-Rx-	30	UIM-RESET
31	USB3.0-Rx+	32	UIM-CLK
33	GND	34	UIM-DATA
35	USB3.0-Tx-	36	UIM-PWR
37	USB3.0-Tx+	38	N/C
39	GND	40	N/C
41	SATA-B+	42	N/C
43	SATA-B-	44	Alert# (PU to P1V8SB only)
45	GND	46	N/C
47	SATA-A-	48	N/C
49	SATA-A+	50	N/C
51	GND	52-56	N/C
57	GND	58-65	N/C
66	SIM_DETECT	67	RESET#
68	N/C	69	N/C
70	P3V3SB	71	GND
72	P3V3SB	73	GND
74	P3V3SB	75	N/C

M.2 Slots (continued)

M.2 Pin Definition (JMD2)			
Pin#	Definition	Pin#	Definition
1	GND	2	P3V3SB
3	USB_D+	4	P3V3SB
5	USB_D-	6	N/C
7	GND	8	CNV_BT_I2S_SCLK
9	CNV_WR_LANE1_DN	10	CNV_RF_RESET_N
11	CNV_WR_LANE1_DP	12	CNV_BT_I2S_SDO
13	GND	14	MODEM_CLKREQ
15	CNV_WR_LANE0_DN	16	N/C
17	CNV_WR_LANE0_DP	18	GND
19	GND	20	UART_BT_WAKE_N
21	CNV_WR_CLK_DN	22	CNV_BRI_RSP
23	CNV_WR_CLK_DP	24	KEY E
25	KEY E	26	KEY E
27	KEY E	28	KEY E
29	KEY E	30	KEY E
31	KEY E	32	CNV_RGI_DT
33	GND	34	CNV_RGI_RSP
35	PETp0	36	CNV_BRI_DT
37	PETn0	38	CLINK_RST_N
39	GND	40	CLINK_DATA
41	PERp0	42	CLINK_CLK
43	PERn0	44	CNV_PA_BLANKING
45	GND	46	CNV_MFUART2_TXD
47	REFCLKp0	48	CNV_MFUART2_RXD
49	REFCLKn0	50	SUSCLK
51	GND	52	PERST0#
53	CLKREQ0#	54	BT_DISABLE2#
55	PEWAKE0#	56	WIFI_DISABLE2#
57	GND	58	N/C
59	CNV_WT_LANE1_DN	60	N/C
61	CNV_WT_LANE1_DP	62	N/C
63	GND	64	CLKIN_XTAL
65	CNV_WT_LANE0_DN	66	N/C
67	CNV_WT_LANE0_DP	68	N/C
69	GND	70	N/C
71	CNV_WT_CLK_DN	72	P3V3SB
73	CNV_WT_CLK_DP	74	P3V3SB
75	GND		



Note: The tables are continued on the next page.

M.2 Slots (continued)

M.2 Pin Definition (JMD3)			
Pin#	Definition	Pin#	Definition
1	GND	2	P3V3
3	GND	4	P3V3
5	PERn3	6	N/C
7	PERp3	8	N/C
9	GND	10	N/C
11	PETn3	12	P3V3
13	PETp3	14	P3V3
15	GND	16	P3V3
17	PERn2	18	P3V3
19	PERp2	20	N/C
21	GND	22	N/C
23	PETn2	24	N/C
25	PETp2	26	N/C
27	GND	28	N/C
29	PERn1	30	N/C
31	PERp1	32	N/C
33	GND	34	N/C
35	PETn1	36	N/C
37	PETp1	38	N/C
39	GND	40	N/C
41	PERn0/SATA-B+	42	N/C
43	PERp0/SATA-B-	44	N/C
45	GND	46	N/C
47	PETn0/SATA-A-	48	N/C
49	PETp0/SATA-A+	50	PERST#
51	GND	52	CLKREQ#
53	REFCLKn	54	N/C
55	REFCLKp	56	N/C
57	GND	58	N/C
59	KEY M	60	KEY M
61	KEY M	62	KEY M
63	KEY M	64	KEY M
65	KEY M	66	KEY M
67	N/C	68	SUSCLK
69	PEDET	70	P3V3
71	GND	72	P3V3
73	GND	74	P3V3
75	GND		

Battery Connector

BT1 is a two-pin connector for an external CMOS battery. Refer to section 3.4 for battery installation instructions. This connector is also used to clear the CMOS. To clear the CMOS, remove the battery, short pins 1-2 for more than 10 seconds and then install the battery.

Bottom Side Layout

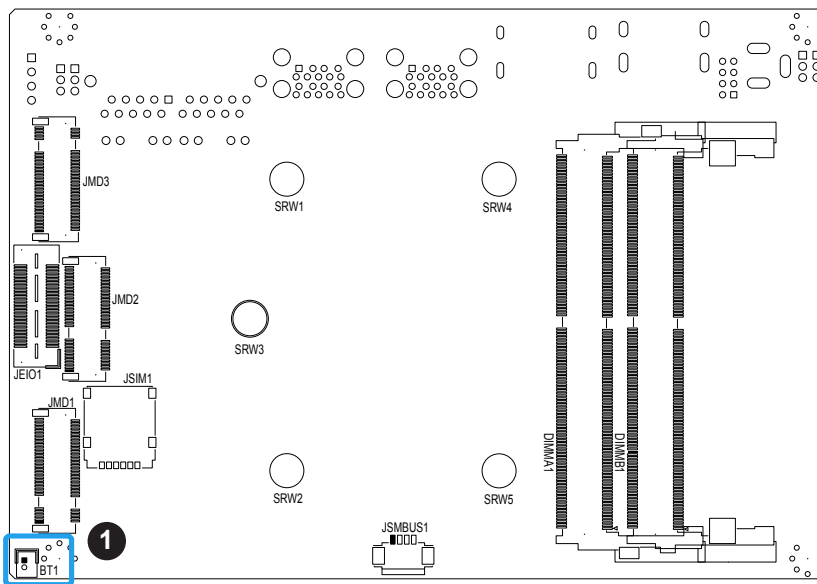

1. Battery Connector

Universal Serial Bus (USB) Ports

The motherboard has four USB 3.1 Gen 2 ports (USB0/1, USB2/3) on the I/O back panel. There are two USB 2.0 headers (USB4/5, USB6/7) that provide four USB connections. These onboard headers can be used to provide front side USB access with a cable (not included).

Front Panel USB 2.0 Header Pin Definitions (USB4/5)			
Pin#	Definition	Pin#	Definition
1	+5V	2	+5V
3	USB_PN4	4	USB_PN5
5	USB_PP4	6	USB_PP5
7	Ground	8	Ground
9	Key	10	NC

Front Panel USB 2.0 Header Pin Definitions (USB6/7)			
Pin#	Definition	Pin#	Definition
1	+5V	2	+5V
3	USB_PN6	4	USB_PN7
5	USB_PP6	6	USB_PP7
7	Ground	8	Ground
9	Key	10	NC

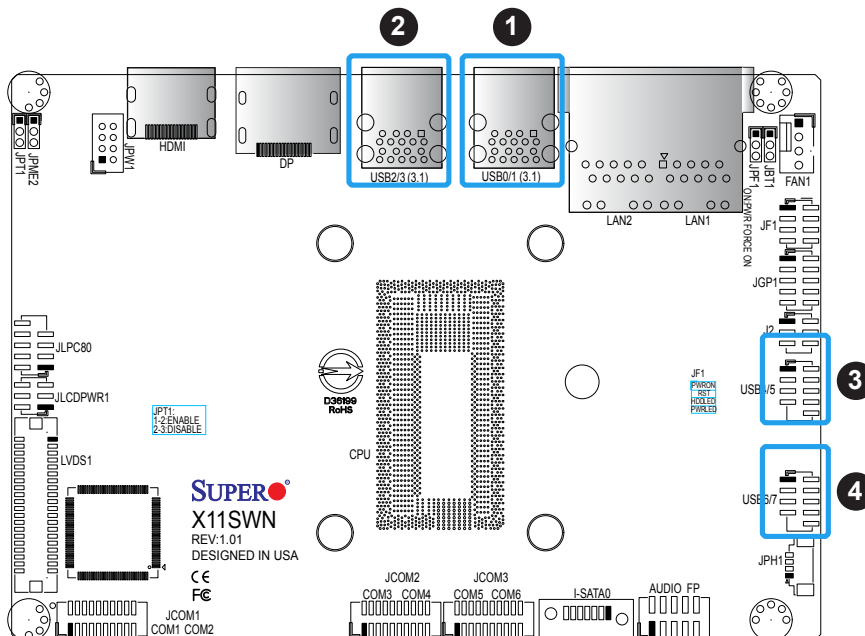

1. USB0/1
2. USB2/3
3. USB4/5
4. USB6/7

LVDS Connector

LVDS1 is the LVDS connector. LVDS (low-voltage differential signaling) is a high-speed digital interface that operates at low power. It is a type of connection that is used with a LVDS LCD panel. The connector combines LCD VCC Power (pins 9-10), LVDS high speed digital interface, backlight power 3.3V (pin 7) and 12V (pins 1-5), backlight enable (pin 15), and dimming control (pin 13). Select the correct LCD VCC power according to the LCD specification by JLCDPWR1 (3.3V/5V/12V) before enabling the LVDS panel. Refer to the tables below for vendor part number, mating, and crimping contact connector information before making the LVDS/backlight cable.

1. LVDS Header

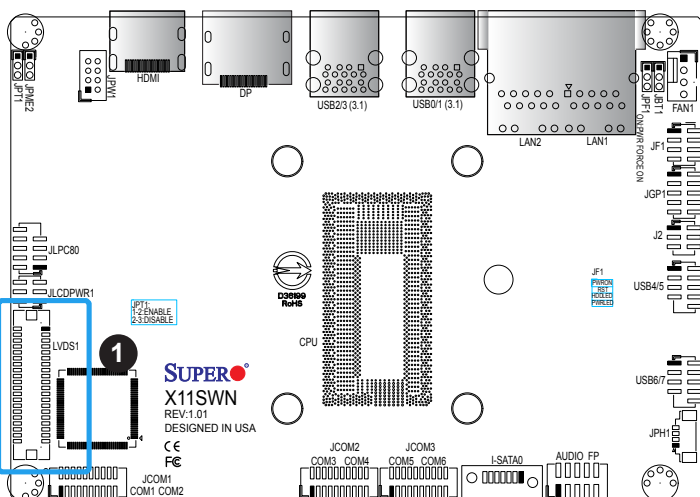

LVDS Connector Pin Definitions			
Pin#	Definition	Pin#	Definition
39	GND	40	GND
37	LVDSB D3N	38	LVDSB D3P
35	LVDSB CLKN	36	LVDSB CLKP
33	LVDSB D2N	34	LVDSB D2P
31	LVDSB D1N	32	LVDSB D1P
29	LVDSB D0N	30	LVDSB D0P
27	GND	28	GND
25	LVDSA D3N	26	LVDSA D3P
23	LVDSA CLKN	24	LVDSA CLKP
21	LVDSA D2N	22	LVDSA D2P
19	LVDSA D1N	20	LVDSA D1P
17	LVDSA D0N	18	LVDSA D0P
15	BKLTEN	16	GND
13	BKLTCTL	14	PVCCEN
11	DDC CLK	12	DDC DATA
9	LCDVCC	10	LCDVCC
7	3.3V	8	GND
5	12V	6	GND
3	12V	4	12V
1	12V	2	12V

LVDS Connector			
Connector	Vendor	Manufacture P/N	Description
Onboard LVDS Connector	HIROSE	DF13E-40DP-1.25V(51)	BOX HEADER, BOARD TO WIRE, 2X20, PITCH 1.25MM, VERT, 1A/PIN, WHITE, 0.2UM GOLD, PA9T, MATING HEIGHT 5.8MM
Mating Connector	HIROSE	DF13-40DS-1.25C	Headers and Wire Housings 1.25MM RECEPT HSNQ 40P DUAL ROW CRIMP
Crimping Contract Connector	HIROSE	DF13G-2630SCFA	Headers and Wire Housings SOCKET CONTACT/REEL AWG26-30

General Purpose I/O Header

The JGP1 (General Purpose Input/Output) header is a general purpose I/O expander on a pin header via the SMBus. Each pin can be configured to be an input pin or output pin. The GPIO is controlled via the PCA9554APW 8-bit GPIO expansion from PCH SMBus. The base address is 0xF040. The expander slave address is 0x4C for WRITE and READ. Refer to the table below for pin definitions.

GPIO Header Pin Definitions			
Pin#	Definition	Pin#	Definition
1	P3V3SB	2	GND
3	GP_P3V3_GP0	4	GP_P3V3_GP4
5	GP_P3V3_GP1	6	GP_P3V3_GP5
7	GP_P3V3_GP2	8	GP_P3V3_GP6
9	GP_P3V3_GP3	10	GP_P3V3_GP7

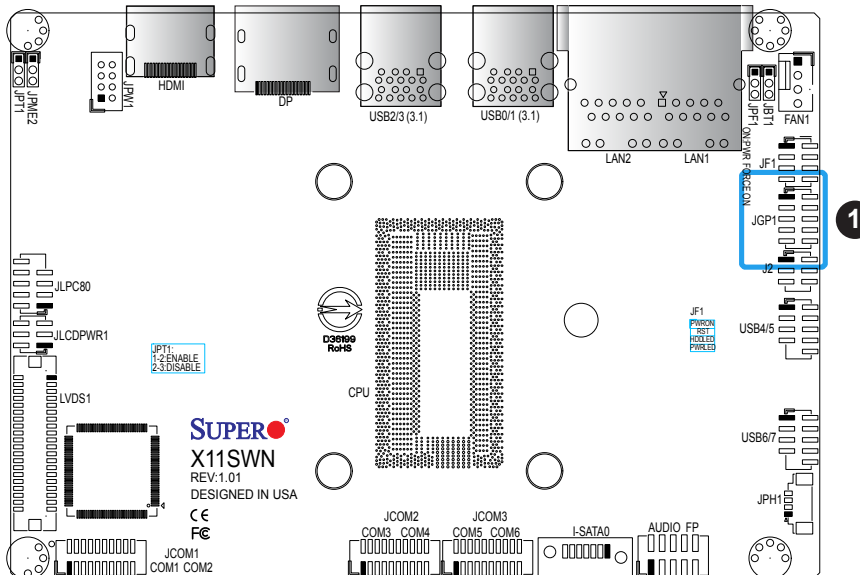

1. General Purpose Header

System Management Bus Header

A System Management Bus header for additional slave devices or sensors is located at JSMBUS1. Refer to the table below for pin definitions.

SMBus Header Pin Definitions	
Pin#	Definition
1	Clock
2	Data
3	Ground
4	NC

Nano SIM Slot

The JSIM1 slot supports a Nano SIM card.

Bottom Side Layout

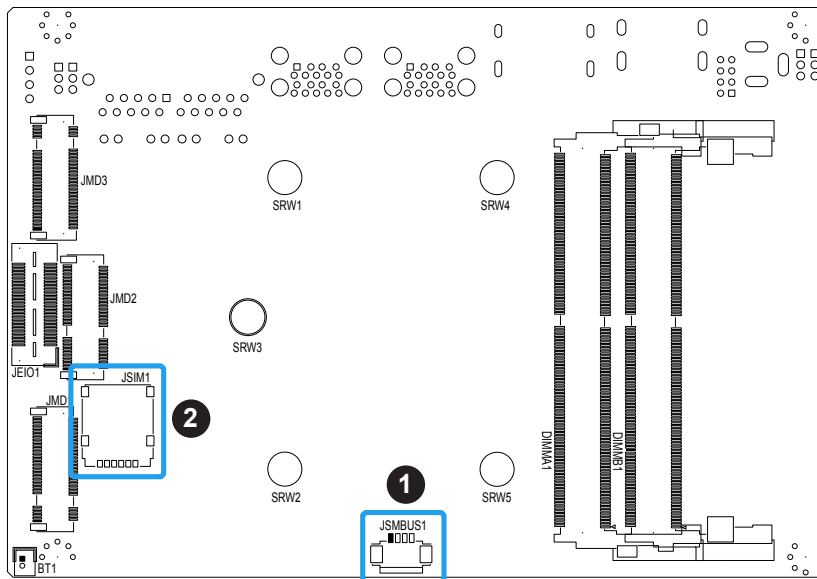

1. SMBus Header
2. Nano SIM Slot

JEIO1

This E/I/O header provides flexibility support for the following functions: PCIe x2, LPC, SMBus, and Power, so that it allows customers to make their own I/O module to fit different kinds of vertical market I/O demands.

Functions
PCI Express
LPC
SMBus
Power
N/C
GND

1. JEIO1

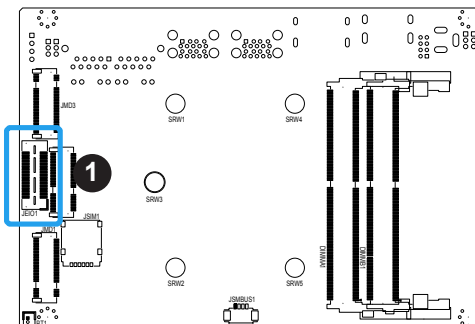

E/I/O Pin Definition					
Pin#	Definition		Pin#	Definition	
1	PCIE_RX_DP0	61 GND	2	PCIE_TX_DP0	
3	PCIE_RX_DN0		4	PCIE_TX_DN0	
5	GND		6	GND	
7	PCIE_RX_DP1		8	PCIE_TX_DP1	
9	PCIE_RX_DN1		10	PCIE_TX_DN0	
11	GND		12	GND	
13	CLK_100M_DP		14	N/C	
15	CLK_100M_DN		16	N/C	
17	GND		62 GND	18	N/C
19	N/C			20	N/C
21	N/C	22		GND	
23	GND	24		N/C	
25	N/C	26		N/C	
27	N/C	28		GND	
29	GND	30		N/C	
31	N/C	32		WAKE_EIO_N	
33	N/C	63 GND		34	N/C
35	GND			36	N/C
37	N/C		38	SMB_CLK	
39	N/C		40	SMB_DAT	
41	P5VSB		42	P3VSB	
43	P5VSB		44	LPC_LFRAME_N	
45	P12VSB		46	LPC_AD3	
47	SOC_LPC_CLKOUT1		64 GND	48	LPC_AD2
49	PLTR_TPM_80PORT_N			50	LPC_AD1
51	LPC_SERIRQ			52	LPC_AD0
53	P3V3	54		P5V	
55	PS_ON_N	56		GND	
57	N/C	58		N/C	
59	N/C	60		N/C	

2.7 Jumper Settings

How Jumpers Work

To modify the operation of the motherboard, jumpers can be used to choose between optional settings. Jumpers create shorts between two pins to change the function of the connector. Pin 1 is identified with a square solder pad on the printed circuit board. See the diagram below for an example of jumping pins 1 and 2. Refer to the motherboard layout page for jumper locations.

 **Note:** On two-pin jumpers, Closed means the jumper is on the pins and Open means the jumper is off.

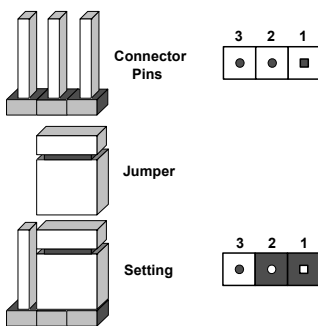

CMOS Clear

JBT1 is used to clear the CMOS. Shut down the system before clearing the CMOS.

CMOS Clear Jumper Settings	
Jumper Setting	Definition
Pins 1-2	Normal Operation (Default)
Pins 2-3	CMOS Clear

JLCDPWR1

Use this jumper to select the power voltage for the LVDS panel. Make sure that the specifications of the cable is compatible with the panel to prevent damage.

LVDS VCC Power Selection Jumper Settings	
Jumper Setting	Definition
Pins 1-3	3.3V (Default)
Pins 3-5	5V
Pins 3-4	12V

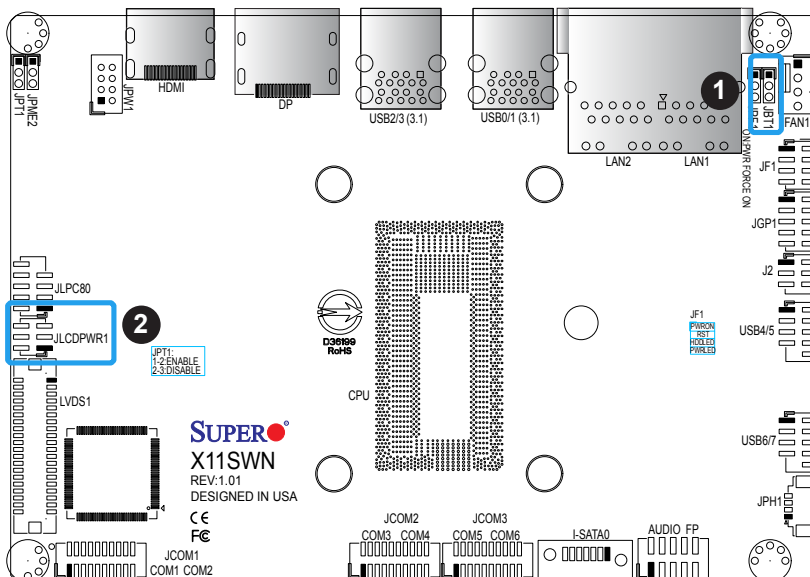

1. CMOS Clear
2. LVDS Power

Manufacturing Mode Select

Close pins 2-3 of jumper JPME2 to bypass SPI flash security and force the system to operate in the manufacturing mode, which allows you to flash the system firmware from a host server for system setting modifications. Refer to the table below for jumper settings.

Manufacturing Mode Jumper Settings	
Jumper Setting	Definition
Pins 1-2	Normal (Default)
Pins 2-3	Manufacturing Mode

Force Power On

Use jumper JPF1 to select the FORCE POWER ON function when the AC power cord is plugged in. When enabling force power on and AC power recovery, the system will boot up automatically without pressing the power button.

Force Power On Jumper Settings	
Jumper Setting	Definition
Pins 1-2	Force Power On (Default) (when AC power cord is plugged)
Pins 2-3	PWR BTN Power On (when AC power cord is plugged)

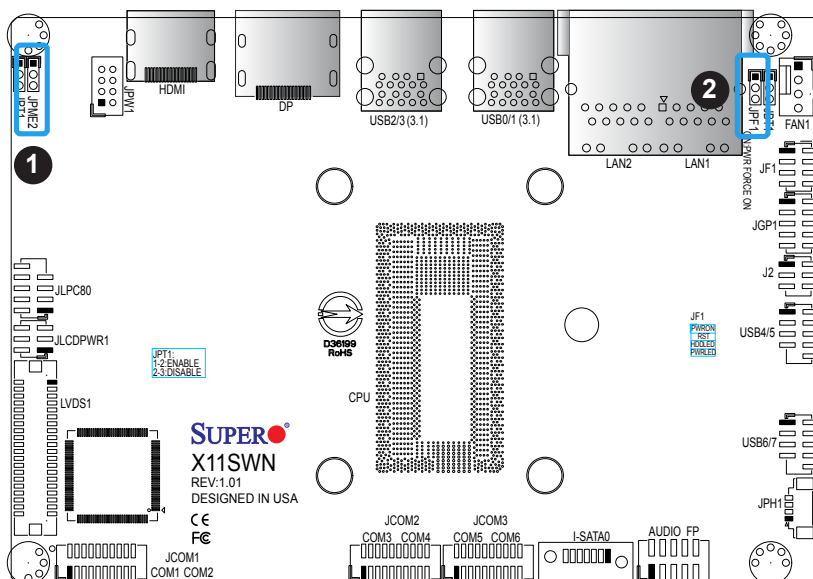

1. Manufacturing Mode
2. Force Power On

2.8 LED Indicators

LAN Port LEDs

Each Ethernet LAN port has two LEDs. The yellow LED on the right side indicates link and activity, while the left LED may be green, amber, or off to indicate the speed of the connection.

LAN1/2 LED (Connection Speed Indicator)	
LED Color	Definition
Off	10 Mb/s
Green	100 Mb/s
Amber	1 Gb/s

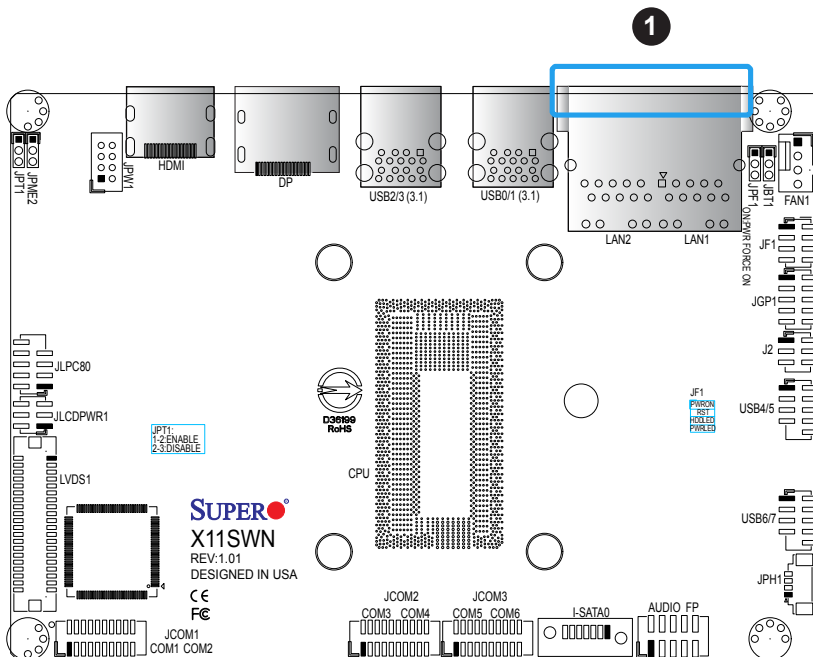

1. LAN LEDs

Chapter 3

Troubleshooting

3.1 Troubleshooting Procedures

Use the following procedures to troubleshoot your system. If you have followed all of the procedures below and still need assistance, refer to the 'Technical Support Procedures' and/or 'Returning Merchandise for Service' section(s) in this chapter. Always disconnect the AC power cord before adding, changing or installing any non hot-swap hardware components.

Before Power On

1. Make sure that there are no short circuits between the motherboard and chassis.
2. Disconnect all ribbon/wire cables from the motherboard, including those for the keyboard and mouse.
3. Remove all add-on cards.
4. Connect the front panel connectors to the motherboard.

No Power

1. Make sure that there are no short circuits between the motherboard and the chassis.
2. Make sure that the 12V DC and/or ATX power connectors are properly connected.
3. Check that the 115V/230V switch, if available, on the power supply is properly set.
4. Turn the power switch on and off to test the system, if applicable.
5. The battery on your motherboard may be old. Check to verify that it still supplies ~3VDC. If it does not, replace it with a new one.

No Video

1. If the power is on but you have no video, remove all add-on cards and cables.
2. Remove all memory modules and turn on the system (if the alarm is on, check the specs of memory modules, reset the memory or try a different one).

Memory Errors

1. Make sure that the memory modules are compatible with the system and that the DIMMs are properly and fully installed. Click on the Tested Memory List link on the motherboard product page to see a list of supported memory.
2. Check if different speeds of DIMMs have been installed. It is strongly recommended that you use the same RAM type and speed for all DIMMs in the system.
3. Make sure that you are using the correct type of Non-ECC DDR4 RDIMM modules recommended by the manufacturer.
4. Check for bad DIMM modules or slots by swapping a single module among all memory slots and check the results.
5. Make sure that all memory modules are fully seated in their slots. Follow the instructions given in Section 2-3 in Chapter 2.
6. Please follow the instructions given in the DIMM population tables listed in Section 2-3 to install your memory modules.

Losing the System's Setup Configuration

1. Make sure that you are using a high-quality power supply. A poor-quality power supply may cause the system to lose the CMOS setup information. Refer to Section 2-7 for details on recommended power supplies.
2. The battery on your motherboard may be old. Check to verify that it still supplies ~3VDC. If it does not, replace it with a new one. If the above steps do not fix the setup configuration problem, contact your vendor for repairs.

When the System Becomes Unstable

A. If the system becomes unstable during or after OS installation, check the following:

1. CPU/BIOS support: Make sure that your CPU is supported and that you have the latest BIOS installed in your system.
2. Memory support: Make sure that the memory modules are supported by testing the modules using memtest86 or a similar utility.



Note: Click on the Tested Memory List link on the motherboard product page to see a list of supported memory.

3. HDD support: Make sure that all hard disk drives (HDDs) work properly. Replace the bad HDDs with good ones.
4. System cooling: Check the system cooling to make sure that all heatsink fans and CPU/system fans, etc., work properly. Check the hardware monitoring settings in the IPMI to make sure that the CPU and system temperatures are within the normal range. Also check the front panel Overheat LED and make sure that it is not on.
5. Adequate power supply: Make sure that the power supply provides adequate power to the system. Make sure that all power connectors are connected. Please refer to our website for more information on the minimum power requirements.
6. Proper software support: Make sure that the correct drivers are used.

B. If the system becomes unstable before or during OS installation, check the following:

1. Source of installation: Make sure that the devices used for installation are working properly, including boot devices such as CD/DVD.
2. Cable connection: Check to make sure that all cables are connected and working properly.
3. Using the minimum configuration for troubleshooting: Remove all unnecessary components (starting with add-on cards first), and use the minimum configuration (but with the CPU and a memory module installed) to identify the trouble areas. Refer to the steps listed in Section A above for proper troubleshooting procedures.
4. Identifying bad components by isolating them: If necessary, remove a component in question from the chassis, and test it in isolation to make sure that it works properly. Replace a bad component with a good one.
5. Check and change one component at a time instead of changing several items at the same time. This will help isolate and identify the problem.
6. To find out if a component is good, swap this component with a new one to see if the system will work properly. If so, then the old component is bad. You can also install the component in question in another system. If the new system works, the component is good and the old system has problems.

3.2 Technical Support Procedures

Before contacting Technical Support, please take the following steps. Also, please note that as a motherboard manufacturer, Supermicro also sells motherboards through its channels, so it is best to first check with your distributor or reseller for troubleshooting services. They should know of any possible problems with the specific system configuration that was sold to you.

1. Please go through the Troubleshooting Procedures and Frequently Asked Questions (FAQ) sections in this chapter or see the FAQs on our website (<http://www.supermicro.com/FAQ/index.php>) before contacting Technical Support.
2. BIOS upgrades can be downloaded from our website (http://www.supermicro.com/ResourceApps/BIOS_IPMI_Intel.html).
3. If you still cannot resolve the problem, include the following information when contacting Supermicro for technical support:

- Motherboard model and PCB revision number
 - BIOS release date/version (This can be seen on the initial display when your system first boots up.)
 - System configuration
4. An example of a Technical Support form is on our website at <http://www.supermicro.com/RmaForm/>.
- Distributors: For immediate assistance, please have your account number ready when placing a call to our Technical Support department. We can be reached by email at support@supermicro.com.

3.3 Frequently Asked Questions

Question: What type of memory does my motherboard support?

Answer: The motherboard supports up to 64GB of Non-ECC SO-DIMM (32GB per SO-DIMM) DDR4 memory with speeds of up to 2400MHz. To enhance memory performance, do not mix memory modules of different speeds and sizes. Please follow all memory installation instructions given on Section 2-3 in Chapter 2.

Question: How do I update my BIOS?

Answer: It is recommended that you **do not** upgrade your BIOS if you are not experiencing any problems with your system. Updated BIOS files are located on our website at http://www.supermicro.com/ResourceApps/BIOS_IPMI_Intel.html. Please check our BIOS warning message and the information on how to update your BIOS on our website. Select your motherboard model and download the BIOS file to your computer. Also, check the current BIOS revision to make sure that it is newer than your BIOS before downloading. Unzip the BIOS file onto a bootable USB device in the UEFI shell. Run the batch file using the format FLASH.NSH filename.rom from your bootable USB device in the UEFI shell to flash the BIOS. Then your system will automatically reboot.

Warning: Do not shut down or reset the system while updating the BIOS to prevent possible system boot failure!)



Note: The SPI BIOS chip used on this motherboard cannot be removed. Send your motherboard back to our RMA Department at Supermicro for repair. For BIOS Recovery instructions, please refer to the AMI BIOS Recovery Instructions posted at <http://www.supermicro.com/support/manuals/>.

3.4 Battery Removal and Installation

Battery Removal

To remove the battery, follow the steps below:

1. Power off your system and unplug your power cable.
2. Remove the battery cable at the BT1 connector on the board.
3. Remove the battery.

Proper Battery Disposal

Please handle used batteries carefully. Do not damage the battery in any way; a damaged battery may release hazardous materials into the environment. Do not discard a used battery in the garbage or a public landfill. Please comply with the regulations set up by your local hazardous waste management agency to dispose of your used battery properly.

Battery Installation

1. Unplug the power cord.
2. Connect the battery cable into the battery connector (BT1) and push it down until you hear a click to ensure that the cable is securely locked.
3. The battery is temporarily placed on the heatsink during shipping (for X11SWN-H/-E/-L/-C with heatsink SKU). Please use the foam tape on the back side of the battery to secure the battery to a flat surface on the bottom of the motherboard or a proper location in the system. DO NOT place the battery on the heatsink during operation.

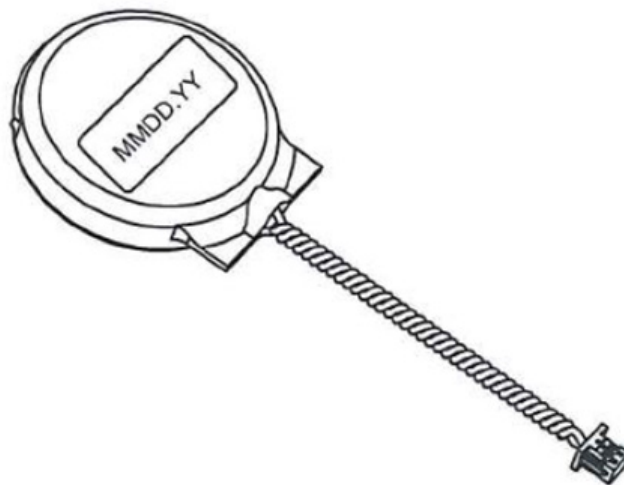

3.5 Returning Merchandise for Service

A receipt or copy of your invoice marked with the date of purchase is required before any warranty service will be rendered. You can obtain service by calling your vendor for a Returned Merchandise Authorization (RMA) number. When returning to the manufacturer, the RMA number should be prominently displayed on the outside of the shipping carton and mailed prepaid or hand-carried. Shipping and handling charges will be applied for all orders that must be mailed when service is complete.

For faster service, RMA authorizations may be requested online (<http://www.supermicro.com/support/rma/>).

This warranty only covers normal consumer use and does not cover damages incurred in shipping or from failure due to the alteration, misuse, abuse or improper maintenance of products.

During the warranty period, contact your distributor first for any product problems.

Chapter 4

UEFI BIOS

4.1 Introduction

This chapter describes the AMIBIOS™ Setup utility for the X11SWN-H motherboard. The BIOS is stored on a chip and can be easily upgraded using a flash program.



Note: Due to periodic changes to the BIOS, some settings may have been added or deleted and might not yet be recorded in this manual. Please refer to the Manual Download area of our website for any changes to BIOS that may not be reflected in this manual.

Starting the Setup Utility

To enter the BIOS Setup Utility, hit the <Delete> key while the system is booting up. (In most cases, the <Delete> key is used to invoke the BIOS setup screen. There are a few cases when other keys are used, such as <F1>, <F2>, etc.) Each main BIOS menu option is described in this manual.

The Main BIOS screen has two main frames. The left frame displays all the options that can be configured. “Grayed-out” options cannot be configured. The right frame displays the key legend. Above the key legend is an area reserved for a text message. When an option is selected in the left frame, it is highlighted in white. Often a text message will accompany it. (Note that BIOS has default text messages built in. We retain the option to include, omit, or change any of these text messages.) Settings printed in **Bold** are the default values.

A " ►" indicates a submenu. Highlighting such an item and pressing the <Enter> key will open the list of settings within that submenu.

The BIOS setup utility uses a key-based navigation system called hot keys. Most of these hot keys (<F1>, <Enter>, <ESC>, <Arrow> keys, etc.) can be used at any time during the setup navigation process.

4.2 Main Setup

When you first enter the AMI BIOS setup utility, you will enter the Main setup screen. You can always return to the Main setup screen by selecting the Main tab on the top of the screen. The Main BIOS setup screen is shown below and the following features will be displayed:

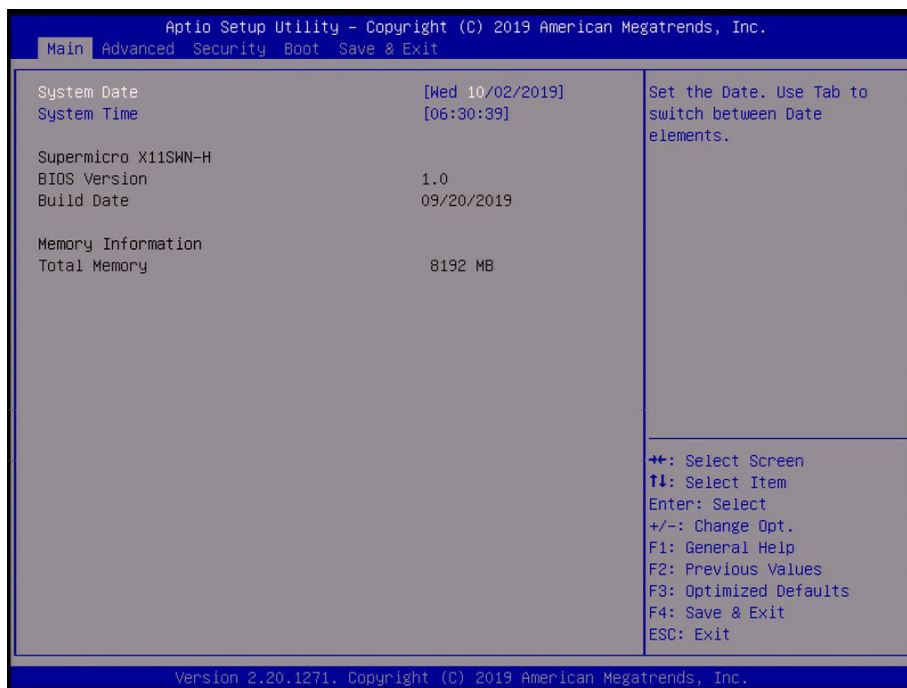

System Date/System Time

Use this option to change the system date and time. Highlight *System Date* or *System Time* using the arrow keys. Enter new values using the keyboard. Press the <Tab> key or the arrow keys to move between fields. The date must be entered in MM/DD/YYYY format. The time is entered in HH:MM:SS format.

 **Note:** The time is in the 24-hour format. For example, 5:30 P.M. appears as 17:30:00. The date's default value is the BIOS build date after RTC reset.

Supermicro X11SWN

BIOS Version

This feature displays the version of the BIOS ROM used in the system.

Build Date

This feature displays the date when the version of the BIOS ROM used in the system was built.

Memory Information

Total Memory

This feature displays the total size of memory available in the system.

4.3 Advanced

Use this menu to configure advanced settings.

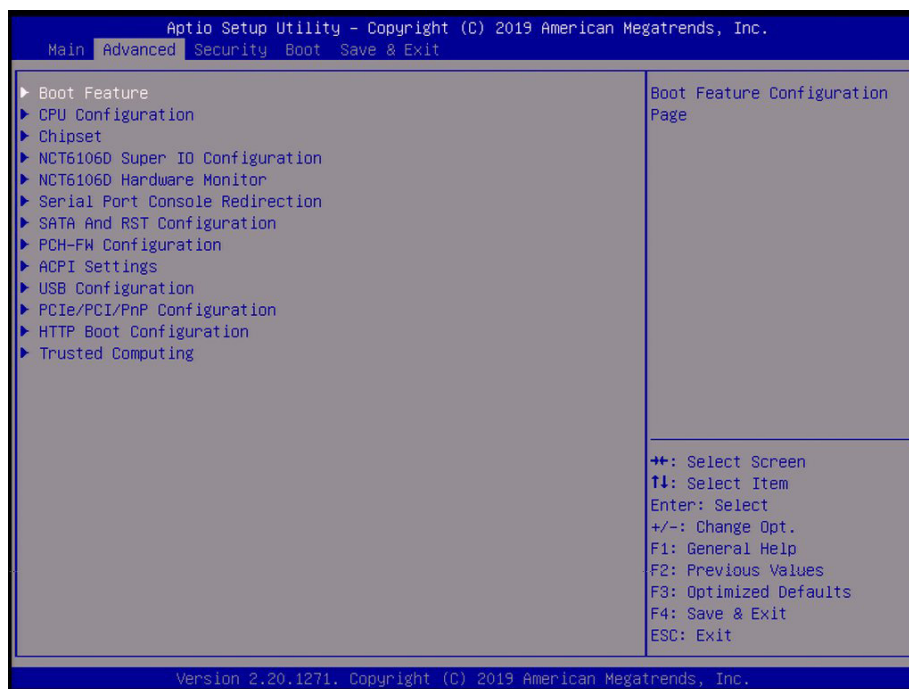

Warning: Take caution when changing the Advanced settings. An incorrect value, a very high DRAM frequency or an incorrect BIOS timing setting may cause the system to malfunction. When this occurs, restore to default manufacturer settings.

► Boot Feature

Fast Boot

Enable this feature to reduce the time the computer takes to boot up. The computer will boot with a minimal set of required devices. This feature does not have an effect on BBS boot options in the Boot tab. The options are **Disabled** and Enabled.

Quiet Boot

Use this feature to select the screen display between POST messages or the OEM logo at bootup. Select Disabled to display the POST messages. Select Enabled to display the OEM logo instead of the normal POST messages. The options are Disabled and **Enabled**.

Startup NumLock State

Use this feature to set the power-on state for the Numlock key. The options are Off and **On**.

Option ROM Messages

Use this feature to set the display mode for the Option ROM. The options are **Force BIOS** and Keep Current.

Wait For "F1" If Error

This feature forces the system to wait until the F1 key is pressed if an error occurs. The options are Disabled and **Enabled**.

Re-try Boot

If this feature is enabled, the BIOS will automatically reboot the system from a specified boot device after its initial boot failure. The options are **Disabled** and EFI Boot.

Port 61h bit-4 Emulation

Select Enabled to enable the emulation of Port 61h bit-4 toggling in SMM (System Management Mode). The options are **Disabled** and Enabled.

Watch Dog Function

If enabled, the Watch Dog timer will allow the system to reboot when it is inactive for more than five minutes. The options are **Disabled** and Enabled.

Restore on AC Power Loss

Use this feature to set the power state after a power outage. Select Power Off for the system power to remain off after a power loss. Select Power On for the system power to be turned on after a power loss. Select Last State to allow the system to resume its last power state before a power loss. The options are Stay Off, Power On, and **Last State**.

Power Button Function

This feature controls how the system shuts down when the power button is pressed. Select 4 Seconds Override for the user to power off the system after pressing and holding the power button for four seconds or longer. Select Instant Off to instantly power off the system as soon as the user presses the power button. The options are **Instant Off** and 4 Seconds Override. This option only works when JPF1 is set to pins 2-3 - PWR BTN Power On. If JPF1 is under pins 1-2 - Force Power On, it will always power on when the AC is plugged in.

► CPU Configuration

The following CPU information will display:

- CPU type
- CPU Signature
- Microcode Patch
- Max CPU Speed
- Min CPU Speed
- Processor Cores
- Hyper Threading Technology
- VMX
- SMX/TXT
- 64-bit
- EIST Technology
- CPU C3 state
- CPU C6 state
- CPU C7 state
- CPU C8 state
- CPU C9 state
- CPU C10 state
- L1 Data Cache
- L1 Instruction Cache
- L2 Cache
- L3 Cache
- L4 Cache

Hardware Prefetcher (Available when supported by the CPU)

If set to Enable, the hardware prefetcher will prefetch streams of data and instructions from the main memory to the L2 cache to improve CPU performance. The options are Disabled and **Enabled**.

Adjacent Cache Prefetch (Available when supported by the CPU)

The CPU prefetches the cache line for 64 bytes if this feature is set to Disabled. The CPU prefetches both cache lines for 128 bytes as comprised if this feature is set to Enable. The options are Disabled and **Enabled**.

Intel (VMX) Virtualization Technology

Use this feature to enable the Vanderpool Technology. This technology allows the system to run several operating systems simultaneously. The options are Disabled and **Enabled**.

Active Processor Cores

This feature determines how many CPU cores will be activated for each CPU. When all is selected, all cores in the CPU will be activated. The options are **All**, 1, 2, and 3.

Hyper-Threading

Select Enabled to support Intel Hyper-threading Technology to enhance CPU performance. The options are Disabled and **Enabled**.

AES

Select Enabled for Intel CPU Advanced Encryption Standard (AES) instructions support to enhance data integrity. The options are Disabled and **Enabled**.

Boot Performance Mode

This feature allows the user to select the performance state that the BIOS will set before the operating system handoff. The options are Power Saving, **Max Non-Turbo Performance**, and Turbo Performance.

Intel® SpeedStep™

Intel SpeedStep Technology allows the system to automatically adjust processor voltage and core frequency to reduce power consumption and heat dissipation. The options are Disabled and **Enabled**.

Intel® Speed Shift Technology

Use this feature to enable or disable Intel Speed Shift Technology support. When this feature is enabled, the Collaborative Processor Performance Control (CPPC) version 2 interface will be available to control CPU P-States. The options are Disabled and **Enabled**.

Turbo Mode

Select Enable for processor cores to run faster than the frequency specified by the manufacturer. The options are Disabled and **Enabled**.

Package Power Limit MSR Lock

Select Enabled to lock the package power limit for the model specific registers. The options are **Disabled** and Enabled.

Power Limit 1 Override

Select Enabled to support average power limit (PL1) override. The options are **Disabled** and Enabled.

Power Limit 1

Use this feature to configure the value for Power Limit 1. The value is in milli watts and the step size is 125mW. Use the number keys on your keyboard to enter the value. Enter 0 to use the manufacture default setting If the value is 0, the BIOS will set PL1 as 1.25* TDP. This feature is hidden when Power Limit 1 Override is Disabled.

Power Limit 2 Override

Select Enabled to support rapid power limit (PL2) override. The options are Disabled and **Enabled**.

Power Limit 2

Use this feature to configure the value for Power Limit 2. The value is in milli watts and the step size is 125mW. Use the number keys on your keyboard to enter the value. Enter 0 to use the manufacture default setting If the value is 0, the BIOS will set PL2 as 1.25* TDP.

1-Core Ratio Limit Override

This increases (multiplies) 1 clock speed in the CPU core in relation to the bus speed when one CPU core is active. Press "+" or "-" on your keyboard to change the value. Enter **44** to use the manufacture default setting.

2-Core Ratio Limit Override

This increases (multiplies) 2 clock speeds in the CPU core in relation to the bus speed when two CPU cores are active. Press "+" or "-" on your keyboard to change the value. Enter **44** to use the manufacture default setting.

3-Core Ratio Limit Override

This increases (multiplies) 3 clock speeds in the CPU core in relation to the bus speed when three CPU cores are active. Press "+" or "-" on your keyboard to change the value. Enter **42** to use the manufacture default setting.

4-Core Ratio Limit Override

This increases (multiplies) 4 clock speeds in the CPU core in relation to the bus speed when four CPU cores are active. Press "+" or "-" on your keyboard to change the value. Enter **42** to use the manufacture default setting.

C states

Use this feature to enable the C-State of the CPU. The options are Disabled and **Enabled**.

Enhanced C-states

Use this feature to enable the enhanced C-State of the CPU. The options are Disabled and **Enabled**.

C-State Auto Demotion

Use this feature to prevent unnecessary excursions into the C-states to improve latency. The options are Disabled, C1, C3, and **C1 and C3**.

C-State Un-demotion

This feature allows the user to enable or disable the un-demotion of C-State. The options are Disabled, C1, C3, and **C1 and C3**.

Package C-State Demotion

Use this feature to enable or disable the Package C-State demotion. The options are **Disabled** and Enabled.

Package C-State Un-demotion

Use this feature to enable or disable the Package C-State un-demotion. The options are **Disabled** and Enabled.

CState Pre-Wake

This feature allows the user to enable or disable the C-State Pre-Wake. The options are Disabled and **Enabled**.

Package C State Limit

Use this feature to set the Package C-State limit. The options are C0/C1, C2, C3, C6, C7, C7s, C8, C9, C10, Cpu Default, and **Auto**.

Monitor/Mwait

Select Enable to enable the Monitor/Mwait instructions. The Monitor instructions monitors a region of memory for writes, and MWait instructions instruct the CPU to stop until the monitored region begins to write. The options are Disabled and **Enabled**.

► Chipset Configuration

Warning: Setting the wrong values in the sections below may cause the system to malfunction.

► System Agent (SA) Configuration

► Memory Configuration

Memory Configuration

- Memory RC Version
- Memory Frequency
- Memory Timing (tCL-tRCD-tRP-tRAS)
- DIMMA1
- DIMMB1

Maximum Memory Frequency

Use this feature to set the maximum memory frequency for onboard memory modules. The options are **Auto**, 1067, 1200, 1333, 1400, 1600, 1800, 1867, 2000, 2133, 2200, 2400, 2600, and 2667.

Max TOLUD

This feature sets the maximum TOLUD value, which specifies the "Top of Low Usable DRAM" memory space to be used by internal graphics devices, GTT Stolen Memory, and TSEG, respectively, if these devices are enabled. The options are **Dynamic**, 1 GB, 1.25 GB, 1.5 GB, 1.75 GB, 2 GB, 2.25 GB, 2.5 GB, 2.75 GB, 3 GB, 3.25 GB, and 3.5 GB.

Memory Scrambler

Use this feature to enable or disable memory scrambler support. The options are Disabled and **Enabled**.

MRC Fast Boot

Use this feature to enable or disable fast path through the memory reference code. The options are Disabled and **Enabled**.

► Graphics Configuration

Graphics Configuration

IGFX VBIOS Version 1015

IGFX GOP Version N/A

Internal Graphics

Select Auto to keep an internal graphics device installed on an expansion slot supported by the CPU to be automatically enabled. The options are **Auto**, Disabled, and Enabled.

IGFX Graphic Output

Use this feature to select the preferred graphic output type. The options are **VGA** and Embedded Display.

****If the feature above is set to Embedded Display, the next five features will become available for configuration:***

Panel select

Use this feature to select the panel resolution. The options are **Use EDID in SPI ROM**, 800x600, 1024x768, 1280x1024, 1366x768, 800x480, 1920x1080, and OEM Define.

Panel Channel Type

Use this feature to select the Panel Channel Type. The options are **Disabled**, Odd Channel, Even Channel, and Both Channel.

Dual LVDS Mode

Use this feature to select a single or dual mode bus for the LVDS display. The options are **Disabled**, Single LVDS Bus Mode, and Dual LVDS Bus Mode.

Panel Color Depth

Use this feature to select the panel color depth. The options are **Disabled**, VESA and JEIDA18 bpp, VESA 24 bpp, and JEIDA 24 bpp.

Backlight Brightness

Use this feature to select the backlight brightness for the panel display. Select a range from 1 to 16.

GTT Size

Use this feature to set the memory size to be used by the graphics translation table (GTT). The options are 2MB, 4MB, and **8MB**.

Aperture Size

Use this feature to set the Aperture size, which is the size of system memory reserved by the BIOS for graphics device use. The options are 128MB, **256MB**, 512MB, 1024MB, and 2048MB.

DVMT Pre-Allocated

Dynamic Video Memory Technology (DVMT) allows dynamic allocation of system memory to be used for video devices to ensure best use of available system memory based on the DVMT 5.0 platform. The options are 0M, **32M**, 64M, 4M, 8M, 12M, 16M, 20M, 24M, 28M, 36M, 40M, 44M, 48M, 52M, 56M, and 60M.

DVMT Total Gfx Mem

Use this feature to set the total memory size to be used by internal graphics devices based on the DVMT 5.0 platform. The options are 128MB, **256MB**, and MAX.

VDD Enable

Enabling this feature will force VDD in the BIOS. The options are Disabled and **Enabled**.

PM Support

Enable this feature to activate Power Management BIOS support. The options are **Enabled** and Disabled.

PAVP Enable

Protected Audio Video Path (PAVP) decodes Intel integrated graphics encrypted video. The options are **Enabled** and Disabled.

Cdynmax Clamping Enable

Enable this feature to activate Cdynmax Clamping. The options are **Enabled** and Disabled.

Graphics Clock Frequency

Use this feature to set the internal graphics clock frequency. The options are 337.5 Mhz, 450 Mhz, 540 Mhz, and **675 Mhz**.

Skip CD Clock Init in S3 resume

Use this feature to enable skipping of the full CD initialization. If set to Disabled, the full CD clock will initialize. The options are Enabled and **Disabled**.

►GT - Power Management Control

RC6 (Render Standby)

Use this feature to enable render standby support. The options are Disabled and **Enabled**.

Maximum GT frequency

Use this feature to define the Maximum GT frequency. Choose between 33MHz (RPN) and 1200MHz (RP0). Any value beyond this range will be clipped to its min/max supported by the CPU. The options are **Default Max Frequency**, 100MHz, 150MHz, 200MHz, 250MHz, 300MHz, 350MHz, 400MHz, 450MHz, 500MHz, 550MHz, 600MHz, 650MHz, 700MHz, 750MHz, 800MHz, 850MHz, 900MHz, 950MHz, 1000MHz, 1050MHz, 1100MHz, 1150MHz, and 1200MHz.

Disable Turbo GT frequency

Use this feature to disable Turbo GT frequency. If set to Enabled, Turbo GT frequency becomes disabled. If set to Disabled, GT frequency limiters will be removed. The options are Enabled and **Disabled**.

VT-d

Select Enabled to activate Intel Virtualization Technology support for Direct I/O VT-d by reporting the I/O device assignments to VMM through the DMAR ACPI Tables. This feature offers fully-protected I/O resource-sharing across the Intel platforms, providing the user with greater reliability, security and availability in networking and data-sharing. The options are Disabled and **Enabled**.

SW Guard Extensions (SGX)

Select Enabled to activate the Software Guard Extensions (SGX). The options are Disabled, Enabled, and **Software Controlled**.

Select Owner EPOCH input type

There are three Owner EPOCH modes (each EPOCH is 64 bit). The options are **No Change in Owner EPOCHs**, Change to New Random Owner EPOCHs, and Manual User Defined Owner EPOCHs.

GNA Device (B0:D8:F0)

Use this feature to enable SA GNA device. The options are **Enabled** and Disabled.

X2APIC Opt Out

The feature "VT-D" must be enabled for this feature to be configurable. Use this feature to enable or disable X2APIC Opt Out. The options are Enabled and **Disabled**.

► PCH-IO Configuration

PCH-IO Configuration

PCH SKU Name Q370

Stepping B0

► PCI Express Configuration

DMI Link ASPM Control

Use this feature to set the ASPM (Active State Power Management) state on the SA (System Agent) side of the DMI Link. The options are Disabled, L0s, L1, L0sL1, and **Auto**.

Peer Memory Write Enable

Use this feature to enable or disable peer memory write. The options are **Disabled** and Enabled.

► M.2 E-Key/M.2 B-Key

ASPM 0

Use this feature to activate the Active State Power Management (ASPM) level for a PCI-E device. Select Auto for the system BIOS to automatically set the ASPM level based on the system configuration. Select Disabled to disable ASPM support. The options are Disabled, L0s, L1, L0sL1, and **Auto**.

L1 Substates

Use this feature to set the PCI Express L1 Substates. The options are Disabled, L1.1, and **L1.1 & L1.2**.

PCIe Speed

Use this feature to select the PCI Express port speed. The options are **Auto**, Gen1, Gen2, and Gen3.

PCIe PLL SSC

Use this feature to enable PCI-E Phase-locked Loop (PLL) Spread Spectrum Clocking (SSC). The options are **Disabled** and Enabled.

IOAPIC 24-119 Entries

Use this feature to enable or disable IOAPIC 24-119 entries. IRQ 24-119 may be used by PCH devices. Disabling those IRQs may cause certain devices to fail. The options are Disabled and **Enabled**.

►NCT6106D Super IO Configuration

NCT6106D Super IO Configuration

Super IO Chip NCT6106D

►Serial Port 1 Configuration

Serial Port 1

Select Enabled to enable the selected onboard serial port. The options are Disabled and **Enabled**.

Device Settings

This feature displays the status of a serial port specified by the user.

Change Settings

This feature specifies the base I/O port address and the Interrupt Request address of a serial port specified by the user. Select Auto to allow the BIOS to automatically assign the base I/O and IRQ address. The options are **Auto**, (IO=3F8h; IRQ=4;), (IO=3F8h; IRQ=3, 4, 5, 6, 7, 9, 10, 11, 12;), (IO=2F8h; IRQ=3, 4, 5, 6, 7, 9, 10, 11, 12;), (IO=3E8h; IRQ=3, 4, 5, 6, 7, 9, 10, 11, 12;), and (IO=2E8h; IRQ=3, 4, 5, 6, 7, 9, 10, 11, 12;).

COM Serial Port Type

Use this feature to select the COM1 port type. The options are **RS232 Mode**, RS422/RS485 Full Duplex Mode, and RS485 Half Duplex Mode.

►Serial Port 2 Configuration

Serial Port 2

Select Enabled to enable the selected onboard serial port. The options are Disabled and **Enabled**.

Device Settings

This feature displays the status of a serial port specified by the user.

Change Settings

This feature specifies the base I/O port address and the Interrupt Request address of a serial port specified by the user. Select Auto to allow the BIOS to automatically assign the base I/O and IRQ address. The options are **Auto**, (IO=2F8h; IRQ=3;), (IO=3F8h; IRQ=3, 4, 5, 6, 7, 9, 10, 11, 12;), (IO=2F8h; IRQ=3, 4, 5, 6, 7, 9, 10, 11, 12;), (IO=3E8h; IRQ=3, 4, 5, 6, 7, 9, 10, 11, 12;), and (IO=2E8h; IRQ=3, 4, 5, 6, 7, 9, 10, 11, 12;).

COM Serial Port Type

Use this feature to select the COM2 port type. The options are **RS232 Mode**, RS422/RS485 Full Duplex Mode, and RS485 Half Duplex Mode.

► Serial Port 3 Configuration

Serial Port 3

Select Enabled to enable the selected onboard serial port. The options are Disabled and Enabled.

Device Settings

This feature displays the status of a serial port specified by the user.

Change Settings

This feature specifies the base I/O port address and the Interrupt Request address of a serial port specified by the user. Select Auto to allow the BIOS to automatically assign the base I/O and IRQ address. The options are **Auto**, (IO=3E8h; IRQ=7;), (IO=3E8h; IRQ=3, 4, 5, 6, 7, 9, 10, 11, 12;), (IO=2E8h; IRQ=3, 4, 5, 6, 7, 9, 10, 11, 12;), (IO=220h; IRQ=3, 4, 5, 6, 7, 9, 10, 11, 12;), and (IO=228h; IRQ=3, 4, 5, 6, 7, 9, 10, 11, 12;).

► Serial Port 4 Configuration

Serial Port 4

Select Enabled to enable the selected onboard serial port. The options are Disabled and Enabled.

Device Settings

This feature displays the status of a serial port specified by the user.

Change Settings

This feature specifies the base I/O port address and the Interrupt Request address of a serial port specified by the user. Select Auto to allow the BIOS to automatically assign the base I/O and IRQ address. The options are **Auto**, (IO=2E8h; IRQ=7;), (IO=3E8h; IRQ=3, 4, 5, 6, 7, 9, 10, 11, 12;), (IO=2E8h; IRQ=3, 4, 5, 6, 7, 9, 10, 11, 12;), (IO=220h; IRQ=3, 4, 5, 6, 7, 9, 10, 11, 12;), and (IO=228h; IRQ=3, 4, 5, 6, 7, 9, 10, 11, 12;).

► Serial Port 5 Configuration

Serial Port 5

Select Enabled to enable the selected onboard serial port. The options are Disabled and Enabled.

Device Settings

This feature displays the status of a serial port specified by the user.

Change Settings

This feature specifies the base I/O port address and the Interrupt Request address of a serial port specified by the user. Select Auto to allow the BIOS to automatically assign the base I/O and IRQ address. The options are **Auto**, (IO=228h; IRQ=7;), (IO=3E8h; IRQ=3, 4, 5, 6, 7, 9, 10, 11, 12;), (IO=2E8h; IRQ=3, 4, 5, 6, 7, 9, 10, 11, 12;), (IO=220h; IRQ=3, 4, 5, 6, 7, 9, 10, 11, 12;), and (IO=228h; IRQ=3, 4, 5, 6, 7, 9, 10, 11, 12;).

► Serial Port 6 Configuration

Serial Port 6

Select Enabled to enable the selected onboard serial port. The options are Disabled and Enabled.

Device Settings

This feature displays the status of a serial port specified by the user.

Change Settings

This feature specifies the base I/O port address and the Interrupt Request address of a serial port specified by the user. Select Auto to allow the BIOS to automatically assign the base I/O and IRQ address. The options are **Auto**, (IO=220h; IRQ=7;), (IO=3E8h; IRQ=3, 4, 5, 6, 7, 9, 10, 11, 12;), (IO=2E8h; IRQ=3, 4, 5, 6, 7, 9, 10, 11, 12;), (IO=220h; IRQ=3, 4, 5, 6, 7, 9, 10, 11, 12;), and (IO=228h; IRQ=3, 4, 5, 6, 7, 9, 10, 11, 12;).

► NCT6106D Hardware Monitor

► System Health

Fan Speed Control Mode

Use this feature to set the fan speed control mode. The options are **Standard**, Quiet, and Full Speed.

- CPU Temperature
- Peripheral Temperature

- System Temperature
- PCH Temperature
- FAN1
- Vcore
- VDIMM
- 12V
- 5V
- AVSB
- 3VCC
- 3VSB
- VBAT

►Serial Port Console Redirection

COM1 - COM6

COM Console Redirection

Select Enabled to enable COM Port 1 for Console Redirection, which will allow a client machine to be connected to a host machine at a remote site for networking. The options are **Disabled** and Enabled.

****If the feature above is set to Enabled, the following features will become available for configuration:***

►Console Redirection Settings

COM Terminal Type

This feature allows you to select the target terminal emulation type for Console Redirection. Select VT100 to use the ASCII Character set. Select VT100+ to add color and function key support. Select ANSI to use the Extended ASCII Character Set. Select VT-UTF8 to use UTF8 encoding to map Unicode characters into one or more bytes. The options are VT100, **VT100+**, VT-UTF8, and ANSI.

COM Bits per second

Use this feature to set the transmission speed for a serial port used in Console Redirection. Make sure that the same speed is used in the host computer and the client computer. A lower transmission speed may be required for long and busy lines. The options are 9600, 19200, 38400, 57600, and **115200** (bits per second).

COM Data Bits

Use this feature to set the data transmission size for Console Redirection. The options are 7 and **8**.

COM Parity

A parity bit can be sent along with regular data bits to detect data transmission errors. Select Even if the parity bit is set to 0, and the number of 1's in data bits is even. Select Odd if the parity bit is set to 0, and the number of 1's in data bits is odd. Select None if you do not want to send a parity bit with your data bits in transmission. Select Mark to add a mark as a parity bit to be sent along with the data bits. Select Space to add a Space as a parity bit to be sent with your data bits. The options are **None**, Even, Odd, Mark, and Space.

COM Stop Bits

A stop bit indicates the end of a serial data packet. Select 1 Stop Bit for standard serial data communication. Select 2 Stop Bits if slower devices are used. The options are **1** and 2.

COM Flow Control

Use this feature to set the flow control for Console Redirection to prevent data loss caused by buffer overflow. Send a "Stop" signal to stop sending data when the receiving buffer is full. Send a "Start" signal to start sending data when the receiving buffer is empty. The options are **None** and Hardware RTS/CTS.

COM VT-UTF8 Combo Key Support

Select Enabled to enable VT-UTF8 Combination Key support for ANSI/VT100 terminals. The options are Disabled and **Enabled**.

COM Recorder Mode

Select Enabled to capture the data displayed on a terminal and send it as text messages to a remote server. The options are **Disabled** and Enabled.

COM Resolution 100x31

Select Enabled for extended-terminal resolution support. The options are Disabled and **Enabled**.

COM Legacy OS Redirection Resolution

Use this feature to select the number of rows and columns used in Console Redirection for legacy OS support. The options are **80x24** and 80x25.

COM Putty KeyPad

This feature selects Function Keys and KeyPad settings for Putty, which is a terminal emulator designed for the Windows OS. The options are **VT100**, LINUX, XTERMR6, SCO, ESCN, and VT400.

COM Redirection After BIOS POST

Use this feature to enable or disable legacy console redirection after BIOS POST. When set to BootLoader, legacy console redirection is disabled before booting the OS. When set to Always Enable, legacy console redirection remains enabled when booting the OS. The options are **Always Enable** and BootLoader.

AMT SOL

AMT SOL Console Redirection

This port is disabled.

Legacy Console Redirection

Redirection COM Port

Use this feature to select a COM port to display redirection of Legacy OS and Legacy OPRM messages. The options are **COM1**, COM2, COM3, COM4, COM5, and COM6.

Serial Port for Out-of-Band Management/Windows Emergency Management Services (EMS)

Console Redirection

Select Enabled to use a COM port selected by the user for EMS Console Redirection. The options are **Disabled** and Enabled.

****If the feature above is set to Enabled, the following features are available for configuration:***

► Console Redirection Settings

Out-of-Band Mgmt Port

The feature selects a serial port in a client server to be used by the Microsoft Windows Emergency Management Services (EMS) to communicate with a remote host server. The options are **COM1**, COM2, COM3, COM4, COM5, and COM6.

Terminal Type

Use this feature to select the target terminal emulation type for Console Redirection. Select VT100 to use the ASCII character set. Select VT100+ to add color and function key support. Select ANSI to use the extended ASCII character set. Select VT-UTF8 to use UTF8 encoding to map Unicode characters into one or more bytes. The options are VT100, VT100+, **VT-UTF8**, and ANSI.

Bits per second

This feature sets the transmission speed for a serial port used in Console Redirection. Make sure that the same speed is used in the host computer and the client computer. A lower transmission speed may be required for long and busy lines. The options are 9600, 19200, 57600, and **115200** (bits per second).

Flow Control

Use this feature to set the flow control for Console Redirection to prevent data loss caused by buffer overflow. Send a "Stop" signal to stop sending data when the receiving buffer is full. Send a "Start" signal to start sending data when the receiving buffer is empty. The options are **None**, Hardware RTS/CTS, and Software Xon/Xoff.

Data Bits

Parity

Stop Bits

► SATA And RST Configuration

SATA Controller(s)

This feature enables or disables the onboard SATA controller supported by the Intel PCH chip. The options are **Enabled** and Disabled.

SATA Mode Selection

Select AHCI to configure a SATA drive specified by the user as an AHCI drive. Select RAID to configure a SATA drive specified by the user as a RAID drive. The options are **AHCI** and RAID.

Aggressive LPM Support

When this feature is enabled, the SATA AHCI controller manages the power usage of the SATA link. The controller will put the link in a low power mode during extended periods of I/O inactivity, and will return the link to an active state when I/O activity resumes. The options are Disabled and **Enabled**.

Storage Option ROM/UEFI Driver

Select UEFI to load the EFI driver for system boot. Select Legacy to load a legacy driver for system boot. The options are Do not Launch, EFI, and **Legacy**.

Serial ATA Port 0 - 2

This feature displays the information detected on the installed SATA drive on the particular SATA port.

- Model number of drive and capacity
- Software Preserve Support

Serial ATA Port 0 - 2 Hot Plug

Set this feature to Enable for hot plug support, which will allow the user to replace a SATA drive without shutting down the system. The options are Disabled and **Enabled**.

Serial ATA Port 0 - 2 Spin Up Device

Set this feature to enable or disable the PCH to initialize the device. The options are **Disabled** and Enabled.

Serial ATA Port 0 - 2 SATA Device Type

Use this feature to specify if the SATA port specified by the user should be connected to a Solid State Drive or a Hard Disk Drive. The options are **Hard Disk Drive** and Solid State Drive.

► PCH-FW Configuration

ME Firmware Version

ME Firmware Mode: Normal Mode

ME Firmware SKU: Corporate SKU

ME FW Image Re-Flash

Use this feature to update the Management Engine firmware. The options are **Disabled** and Enabled.

Manageability Features State

Enabled this feature to allow system administrators to configure the ME BIOS extension (MEBx) configuration settings. The options are Disabled and **Enabled**.

AMT BIOS Features

Disable this feature to deny access to the MEBx setup. The options are **Disabled** and **Enabled**.

****If the feature "AMT BIOS Features" is set to Enabled, the AMT Configuration submenu will be available for configuration:***

▶AMT Configuration

ASF support

Use this feature to enable or disable Alert Standard Format support. This feature sends an alert about a potential issue when the operating system is in a sleep state. The options are **Disabled** and **Enabled**.

USB Provisioning of AMT

Use this feature to enable or disable USB provisioning. The options are **Disabled** and **Enabled**.

▶CIRA Configuration

Activate Remote Assistance Process

Use this feature to activate Remote Assistance. Enabling this feature will also trigger the CIRA boot. The options are **Disabled** and **Enabled**.

****If the feature "Activate Remote Assistance Process" above is set to Enabled, the feature below will be available for configuration:***

CIRA Timeout

Use this feature to set the timeout value for MPS connection. Use **0** for the default timeout value of 60 seconds.

▶ASF Configuration

PET Progress

Use this feature to enable or disable PET Events Progress to receive PET Events alerts. The options are **Disabled** and **Enabled**.

WatchDog

Select **Enabled** to allow AMT to reset or power down the system if the operating system or BIOS hangs or crashes. The options are **Disabled** and **Enabled**.

OS Timer / BIOS Timer

These options appear if Watch Dog (above) is enabled. This is a timed delay in seconds, before a system power down or reset after a BIOS or operating system failure is detected. Enter the value in seconds.

ASF Sensors Table

Enable this feature for the ASF Sensor Table to be added into the ASF! ACPI table. The options are **Disabled** and Enabled.

►Secure Erase Configuration

Secure Erase mode

Select Real to securely erase a solid state drive. The options are **Simulated** and Real.

Force Secure Erase

Select Enabled to force a secure erase of the solid state drive on the next boot. The options are **Disabled** and Enabled.

►OEM Flags Settings

MEBx hotkey Pressed

Use this feature to specify whether the MEBx hotkey should be enabled during the system boot. The options are **Disabled** and Enabled.

MEBx Selection Screen

Use this feature to select the type of MEBx selection screen. Press 1 to enter the ME Configuration screen and 2 to initiate a remote connection. Network access must be activated for a remote connection. The options are **Disabled** and Enabled.

Hide Unconfigure ME Confirmation Prompt

Use this feature to hide the unconfigure ME confirmation prompt. The options are **Disabled** and Enabled.

MEBx OEM Debug Menu Enable

Use this feature to enable or disable the OEM debug menu in MEBx. The options are **Disabled** and Enabled.

Unconfigure ME

Use this feature to reset the MEBx password to default. The options are **Disabled** and Enabled.

►MEBx Resolution Settings

Non-UI Mode Resolution

Use this feature to specify the resolution for the non-UI text mode. The options are **Auto**, 80x25, and 100x31.

UI Mode Resolution

Use this feature to specify the resolution for the UI text mode. The options are **Auto**, 80x25, and 100x31.

Graphics Mode Resolution

Use this feature to specify the resolution for the graphics mode. The options are **Auto**, 640x480, 800x600, and 1024x768.

►ACPI Settings

Use this feature to configure Advanced Configuration and Power Interface (ACPI) power management settings for your system.

ACPI Sleep State

Use this feature to select the ACPI Sleep State that the system will enter into when the suspend button is activated. The options are Suspend Disabled and **S3 (Suspend to RAM)**.

High Precision Event Timer

Select Enabled to activate the High Precision Event Timer (HPET) that produces periodic interrupts at a much higher frequency than a Real-time Clock (RTC) does in synchronizing multimedia streams, providing smooth playback and reducing the dependency on other timestamp calculation devices, such as an x86 RDTSC Instruction embedded in the CPU. The High Performance Event Timer is used to replace the 8254 Programmable Interval Timer. The options are Disabled and **Enabled**.

Native PCIE Enable

Enable this feature to grant control of PCI Express Native hot plug, PCI Express Power Management Events, and PCI Express Capability Structure Control. The options are Disabled and **Enabled**.

Native ASPM

Select Enabled for the operating system to control the ASPM, or Disabled for the BIOS to control the ASPM. The options are Auto, Enabled, and **Disabled**.

Headless Mode Support

Enable this feature for the system to function without a keyboard, monitor, or mouse attached. The options are **Disabled** and **Enabled**.

►USB Configuration

USB Configuration

USB Module Version: 21

USB Controllers: 1 XHCI

USB Devices: 1 Keyboard

Legacy USB Support

Select **Enabled** to support onboard legacy USB devices. Select **Auto** to disable legacy support if there are no legacy USB devices present. Select **Disable** to have all USB devices available for EFI applications only. The options are **Enabled**, **Disabled**, and **Auto**.

XHCI Hand-off

This is a work-around solution for operating systems that do not support XHCI (Extensible Host Controller Interface) hand-off. The XHCI ownership change should be claimed by the XHCI driver. The settings are **Enabled** and **Disabled**.

USB Mass Storage Driver Support

Select **Enabled** for USB mass storage device support. The options are **Disabled** and **Enabled**.

Port 60/64 Emulation

Select **Enabled** for I/O port 60h/64h emulation support, which in turn, will provide complete legacy USB keyboard support for the operating systems that do not support legacy USB devices. The options are **Disabled** and **Enabled**.

►PCIe/PCI/PnP Configuration

Option ROM execution

Video

Use this feature to select the execution of the video OpROM. The options are **Do not launch**, **UEFI**, and **Legacy**.

Above 4G Decoding (Available if the system supports 64-bit PCI decoding)

Select **Enabled** to decode a PCI device that supports 64-bit in the space above 4G Address. The options are **Disabled** and **Enabled**.

SR-IOV Support

Use this feature to enable or disable Single Root IO Virtualization Support. The options are **Disabled** and Enabled.

BME DMA Mitigation

Enable this feature to help block DMA attacks. The options are **Disabled** and Enabled.

NVMe Firmware Source

Use this feature to select the NVMe firmware to support booting. The options are **Vendor Defined Firmware** and AMI Native Support. The default option, Vendor Firmware, is pre-installed on the drive and may resolve errata or enable innovative functions for the drive. The other option, AMI Native Support, is offered by the BIOS with a generic method.

Consistent Device Name Support

Use this feature to consistently name onboard devices and slots. The options are Disabled and Enabled.

PCIe/PCI/PnP Configuration

M.2 E-Key OPROM

Use this feature to select which firmware to be loaded for the add-on card in this slot. The options are Disabled, **Legacy**, and EFI.

M.2 M-Key OPROM

Use this feature to select which firmware to be loaded for the add-on card in this slot. The options are Disabled, **Legacy**, and EFI.

Onboard LAN1 Support

Use this feature to select which firmware to be loaded for LAN port 1 used for system boot. The options are Disabled and **Enabled**.

Onboard LAN2 Support

Use this feature to select which firmware to be loaded for LAN port 2 used for system boot. The options are Disabled and **Enabled**.

Onboard LAN Option ROM Type

Use this feature to select which firmware to be loaded for onboard LAN devices. The options **Legacy** and EFI. Select Legacy to display and configure the onboard LAN Option ROM features.

Onboard LAN1 Option ROM

Use this feature to select which firmware function to be loaded for LAN port 1 used for system boot. The options are Disabled and **PXE**.

Onboard LAN2 Option ROM

Use this feature to select which firmware function to be loaded for LAN port 2 used for system boot. The options are **Disabled**, PXE, and iSCSI.

Network Stack

Select Enabled to enable PXE (Preboot Execution Environment) or UEFI (Unified Extensible Firmware Interface) for network stack support. The options are Disabled and **Enabled**.

****If the feature above is set to Enabled, the features below will be available for configuration:***

Ipv4 PXE Support

Select Enabled to enable IPv4 PXE boot support. The options are Disabled and **Enabled**.

Ipv4 HTTP Support

Select Enabled to enable IPv4 HTTP boot support. The options are **Disabled** and Enabled.

Ipv6 PXE Support

Select Enabled to enable IPv6 PXE boot support. The options are Disabled and **Enabled**.

Ipv6 HTTP Support

Select Enabled to enable IPv6 HTTP boot support. The options are **Disabled** and Enabled.

IPSEC Certificate

The feature appears if Network Stack is enabled. Internet Protocol Security (IPSEC) offers a secure connection for remote computers using a secure tunnel. The options are Disabled and **Enabled**.

PXE boot wait time

Use this feature to specify the wait time to press the ESC key to abort the PXE boot. Press "+" or "-" on your keyboard to change the value. The default setting is **0**.

Media detect count

Use this feature to specify the number of times media will be checked. Press "+" or "-" on your keyboard to change the value. The default setting is **1**.

► HTTP BOOT Configuration

HTTP BOOT Configuration

Http Boot One Time

Use this feature to create the HTTP boot option. The options are **Disabled** and **Enabled**.

Input the description

Highlight the feature and press enter to create a description.

Boot URI

Highlight the feature and press enter to create a boot URI.

► Trusted Computing

The X11SWN-H/-E/-L/-C supports TPM 1.2 and 2.0. The following Trusted Platform Module (TPM) information will display if a TPM 2.0 module is detected:

TPM20 Device Found

Vendor:

Firmware Version:

Security Device Support

If this feature and the TPM jumper on the motherboard are both set to **Enabled**, onboard security devices will be enabled for TPM support to enhance data integrity and network security. Reboot the system for a change on this setting to take effect. The options are **Disabled** and **Enabled**.

The following TPM information will be displayed:

- Active PCR banks
- Available PCR banks

****If the feature "Security Device Support" is enabled, the following features are available for configuration:***

SHA-1 PCR Bank

Use this feature to disable or enable the SHA-1 Platform Configuration Register (PCR) bank for the installed TPM device. The options are **Disabled** and **Enabled**.

SHA256 PCR Bank

Use this feature to disable or enable the SHA256 Platform Configuration Register (PCR) bank for the installed TPM device. The options are **Disabled** and **Enabled**.

Pending Operation

Use this feature to schedule a TPM-related operation to be performed by a security device for system data integrity. The options are **None** and TPM Clear.



Note: Your system will reboot to carry out a pending TPM operation.

Pending Operation

Use this feature to schedule a TPM-related operation to be performed by a security device for system data integrity. Your system will reboot to carry out a pending TPM operation. The options are **None** and TPM Clear.

Platform Hierarchy

Use this feature to disable or enable platform hierarchy for platform protection. The options are Disabled and **Enabled**.

Storage Hierarchy

Use this feature to disable or enable storage hierarchy for cryptographic protection. The options are Disabled and **Enabled**.

Endorsement Hierarchy

Use this feature to disable or enable endorsement hierarchy for privacy control. The options are Disabled and **Enabled**.

TPM2.0 UEFI Spec Version

Use this feature to specify the TPM UEFI spec version. TCG 1.2 has support for Windows® 2012, Windows 8, and Windows 10. TCG 2 has support for Windows 10 or later. The options are TCG_1_2 and **TCG_2**.

Physical Presence Spec Version

Use this feature to select the PPI spec version. The options are 1.2 and **1.3**.

PH Randomization

Use this feature to disable or enable Platform Hierarchy (PH) Randomization. The options are **Disabled** and Enabled.

TXT Support

Intel TXT (Trusted Execution Technology) helps protect against software-based attacks and ensures protection, confidentiality and integrity of data stored or created on the system. Use this feature to enable or disable TXT Support. The options are **Disabled** and Enabled.

4.4 Security

Use this menu to configure the security settings.

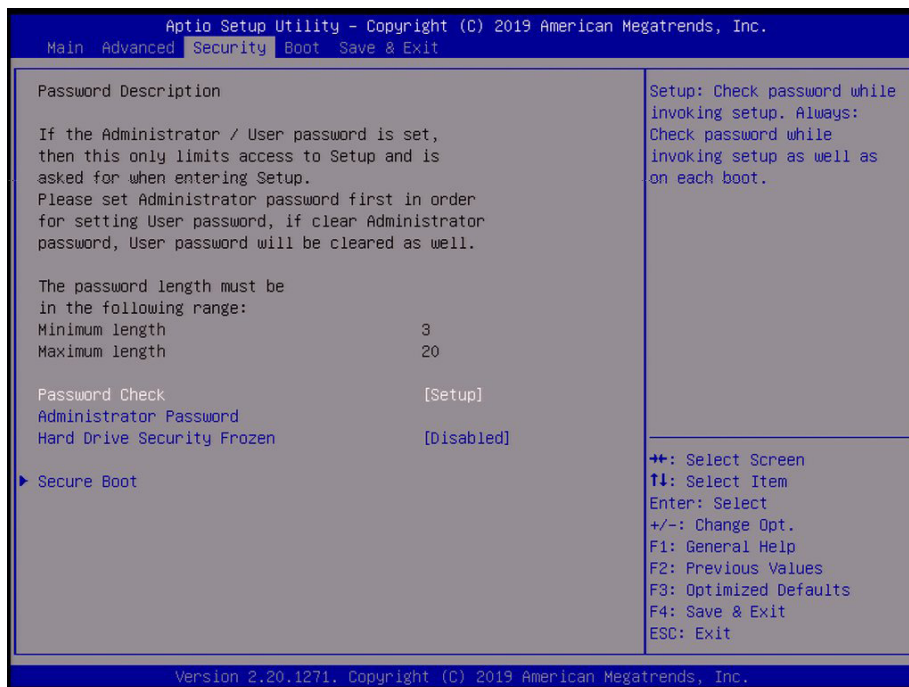

Password Check

Select Setup for the system to check for a password at Setup. Select Always for the system to check for a password at bootup or upon entering the BIOS Setup utility. The options are **Setup** and **Always**.

Administrator Password

Use this feature to set the administrator password which is required to enter the BIOS setup utility. The length of the password should be from 3 to 20 characters long.

Hard Drive Security Frozen

Use this feature to disable or enable the BIOS security frozen command to SATA and NVMe devices. The options are Enabled and **Disabled**.

▶ Secure Boot

System Mode

Secure Boot

Attempt Secure Boot

Select Enable for secure boot support to ensure system security at bootup. The options are **Disabled** and Enabled.

Secure Boot Mode

This feature allows you to select the desired secure boot mode for the system. The options are Standard and **Custom**.

**If Secure Boot Mode is set to Custom, Key Management features are available for configuration:*

CSM Support

This feature is for manufacturing debugging purposes.

▶ Key Management

Vendor Keys

Provision Factory Default keys

Select Enabled to install the default Secure Boot keys set by the manufacturer. The options are **Disabled** and Enabled.

**If the feature above is set to Enabled, the next four features are available for configuration:*

▶ Install Factory Default Keys

Select Yes to install all factory keys to the default settings. The options are Yes and No.

▶ Reset to Setup Mode

Select Yes to delete all Secure Boot key databases and force the system to Setup Mode. The options are Yes and No.

▶ Save all Secure Boot variables

Use this feature to copy the NVRAM contents of the secure boot variables to a file.

▶ Enroll Efi Image

This feature allows the image to run in Secure Boot mode.

Device Guard Ready**▶ Remove 'UEFI CA' from DB**

Use this feature to remove the Microsoft UEFI CA certificate from the database. The options are Yes and No.

▶ Restore DB Defaults

Select Yes to restore all DBs to the default settings. The options are Yes and No.

Secure Boot variable | Size | Keys# | Key Source**▶ Platform Key (PK)****Update**

Select Yes to load a factory default PK or No to load from a file on an external media.

▶ Key Exchange Keys (KEK)**Update**

Select Yes to load a factory default KEK or No to load from a file on an external media.

Append

Select Yes to add the KEK from the manufacturer's defaults list to the existing KEK. Select No to load the KEK from a file. The options are Yes and No.

▶ Authorized Signatures**Update**

Select Yes to load a factory default db or No to load from a file on an external media.

Append

Select Yes to add the db from the manufacturer's defaults list to the existing db. Select No to load the db from a file. The options are Yes and No.

▶ Forbidden Signatures**Update**

Select Yes to load a factory default dbx or No to load from a file on an external media.

Append

Select Yes to add the dbx from the manufacturer's defaults list to the existing dbx. Select No to load the dbx from a file. The options are Yes and No.

► **Authorized TimeStamps**

Update

Select Yes to load a factory default dbt or No to load from a file on an external media.

Append

Select Yes to add the dbt from the manufacturer's defaults list to the existing dbt. Select No to load the dbt from a file. The options are Yes and No.

► **OsRecovery Signatures**

Update

Select Yes to load a factory default dbr or No to load from a file on an external media.

Append

Select Yes to add the dbr from the manufacturer's defaults list to the existing dbr. Select No to load the dbr from a file. The options are Yes and No.

4.5 Boot

Use this menu to configure boot settings:

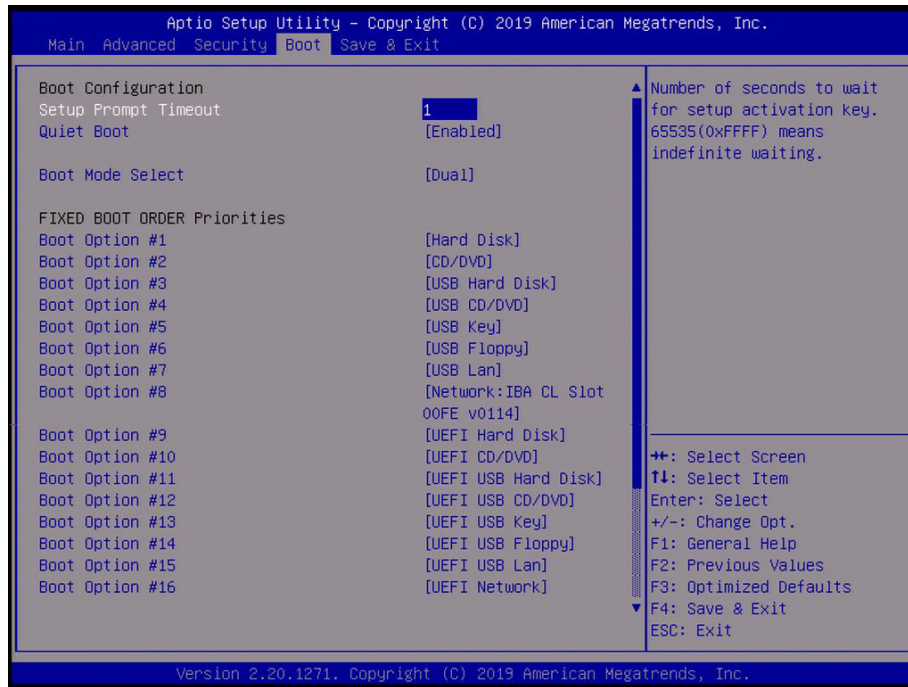

Setup Prompt Timeout

Use this feature to specify the length of time (in seconds) for the BIOS to wait before rebooting the system when the setup activation key is pressed. Enter the value of 65535 (0xFFFF) for the BIOS to wait indefinitely. The default setting is 1.

Quiet Boot

Use this feature to select the screen display between POST messages or the OEM logo at bootup. Select Disabled to display the POST messages. Select Enabled to display the OEM logo instead of the normal POST messages. The options are Disabled and **Enabled**.

Boot Mode Select

Use this feature to select the boot mode. The options are Legacy, UEFI, and **Dual**.

Fixed BOOT ORDER Priorities

This option prioritizes the order of bootable devices that the system to boot from. Press <Enter> on each entry from top to bottom to select devices.

- Boot Option #1
- Boot Option #2
- Boot Option #3

- Boot Option #4
- Boot Option #5
- Boot Option #6
- Boot Option #7
- Boot Option #8
- Boot Option #9
- Boot Option #10
- Boot Option #11
- Boot Option #12
- Boot Option #13
- Boot Option #14
- Boot Option #15
- Boot Option #16
- Boot Option #17

► **Delete Boot Option**

Use this feature to select a boot device to delete from the boot priority list.

► **Delete Driver Option**

Use this feature to remove an EFI driver option from the driver order.

► **UEFI Application Boot Priorities**

- Boot Option # - This feature sets the system boot order of detected devices. The options are **[the list of detected boot device(s)]** and Disabled.

► **NETWORK Drive BBS Priorities**

- Boot Option # - This feature sets the system boot order of detected devices. The options are **[the list of detected boot device(s)]** and Disabled.

4.6 Save & Exit

Use this menu to configure save and exit settings.

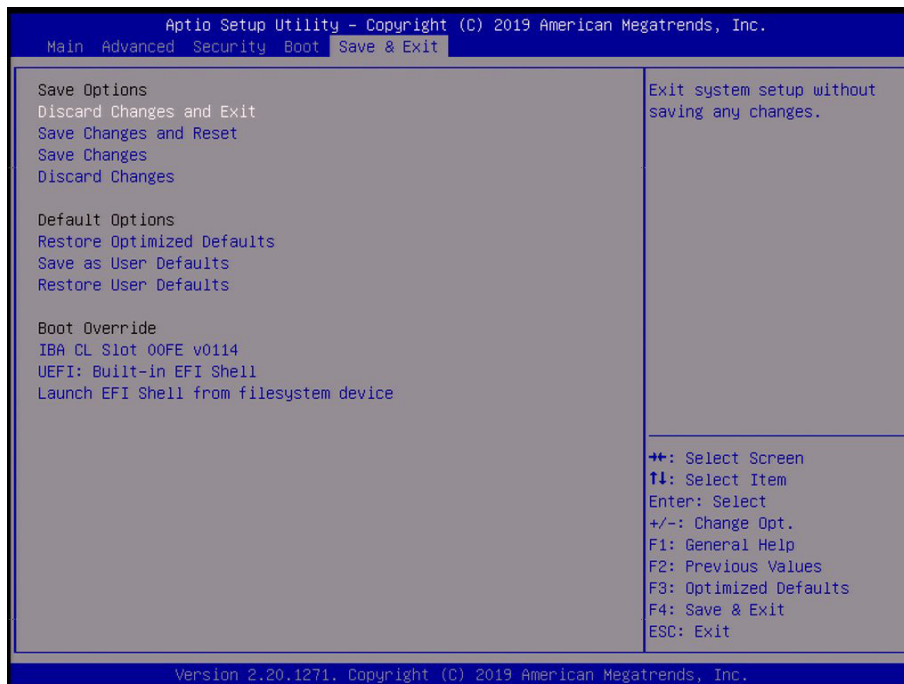

Save Options

Discard Changes and Exit

Select this feature to quit the BIOS Setup without making any permanent changes to the system configuration and reboot the computer. Select Discard Changes and Exit from the Exit menu and press <Enter>.

Save Changes and Reset

When you have completed the system configuration changes, select this option to save all changes made and reset the system.

Save Changes

When you have completed the system configuration changes, select this option to save all changes made. This will not reset (reboot) the system.

Discard Changes

Select this feature and press <Enter> to discard all the changes and return to the AMI BIOS Utility Program.

Default Options

Restore Defaults

To set this feature, select Restore Optimized Defaults and press <Enter>. These are factory settings designed for maximum system performance but not for maximum stability.

Save as User Defaults

To set this feature, select Save as User Defaults from the Exit menu and press <Enter>. This enables the user to save any changes to the BIOS setup for future use.

Restore User Defaults

To set this feature, select Restore User Defaults from the Exit menu and press <Enter>. Use this feature to retrieve user-defined settings that were saved previously.

Boot Override

Other boot options are listed in this section. The system will boot to the selected boot option.

IBA GE Slot 00FE v0114

UEFI: Built-in EFI Shell

Launch EFI Shell from filesystem device

Appendix A

BIOS Codes

A.1 BIOS Error POST Codes

During the POST (Power-On Self-Test) routines, which are performed upon each system boot, errors may occur.

Non-fatal errors are those which, in most cases, allow the system to continue to boot. These error messages normally appear on the screen.

Fatal errors will not allow the system to continue with bootup. If a fatal error occurs, you should consult with your system manufacturer for possible repairs.

A.2 Additional BIOS POST Codes

The AMI BIOS supplies additional checkpoint codes, which are documented online at <http://www.supermicro.com/support/manuals/> ("AMI BIOS POST Codes User's Guide").

When BIOS performs the Power On Self Test, it writes checkpoint codes to I/O port 0080h. If the computer cannot complete the boot process, a diagnostic card can be attached to the computer to read I/O port 0080h (Supermicro p/n AOM-SPI80-V).

For information on AMI updates, please refer to <http://www.ami.com/products/>.

Appendix B

Software Installation

B.1 Installing Software Programs

The Supermicro website that contains drivers and utilities for your system is at <https://www.supermicro.com/wdl/driver>. Some of these must be installed, such as the chipset driver.

After accessing the website, go into the CDR_Images (in the parent directory of the above link) and locate the ISO file for your motherboard. Download this file to create a DVD of the drivers and utilities it contains. (You may also use a utility to extract the ISO file if preferred.)

After creating a DVD with the ISO files, insert the disk into the DVD drive on your system and the display shown in Figure B-1 should appear.

Another option is to go to the Supermicro website at <http://www.supermicro.com/products/>. Find the product page for your motherboard here, where you may download individual drivers and utilities to your hard drive or a USB flash drive and install from there.

 **Note:** To install the Windows operating system, please refer to the instructions posted on our website at <http://www.supermicro.com/support/manuals/>.

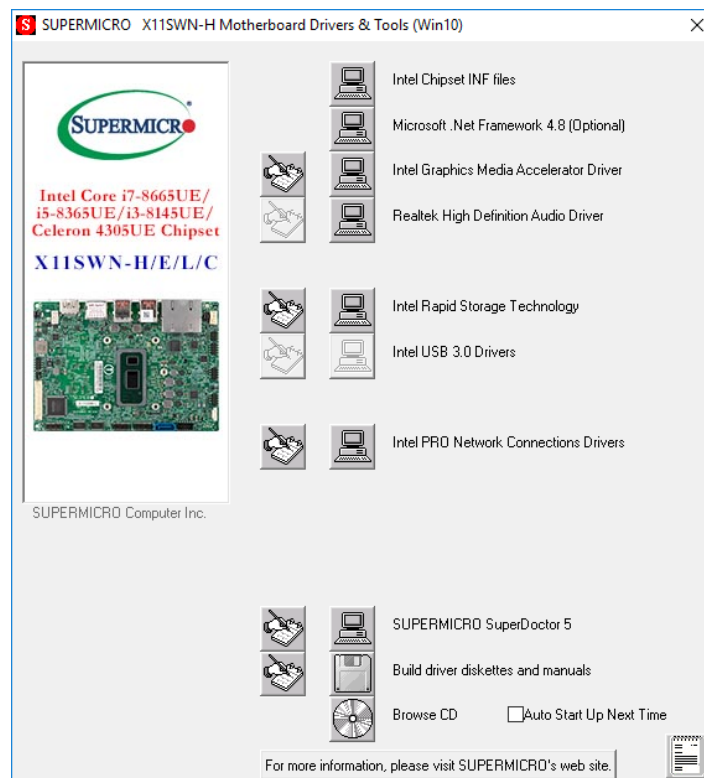

Figure B-1. Driver/Tool Installation Display Screen

Click the icons showing a hand writing on the paper to view the readme files for each item. Click a computer icon to the right of an item to install an item (from top to bottom) one at a time. After installing each item, you must reboot the system before proceeding with the next item on the list. The bottom icon with a DVD on it allows you to view the entire contents of the DVD.

When making a storage driver disk by booting into a driver DVD, please set the SATA Configuration to "Compatible Mode" and configure SATA as IDE in the BIOS Setup. After making the driver disk, be sure to change the SATA settings back to your original settings.

B.2 SuperDoctor® 5

The Supermicro SuperDoctor 5 is a hardware monitoring program that functions in a command-line or web-based interface in Windows and Linux operating systems. The program monitors system health information such as CPU temperature, system voltages, system power consumption, fan speed, and provides alerts via email or Simple Network Management Protocol (SNMP).

SuperDoctor 5 comes in local and remote management versions and can be used with Nagios to maximize your system monitoring needs. With SuperDoctor 5 Management Server (SSM Server), you can remotely control power on/off and reset chassis intrusion for multiple systems with SuperDoctor 5 or IPMI. SD5 Management Server monitors HTTP, FTP, and SMTP services to optimize the efficiency of your operation.



Note: The default Username and Password for SuperDoctor 5 is ADMIN / ADMIN.

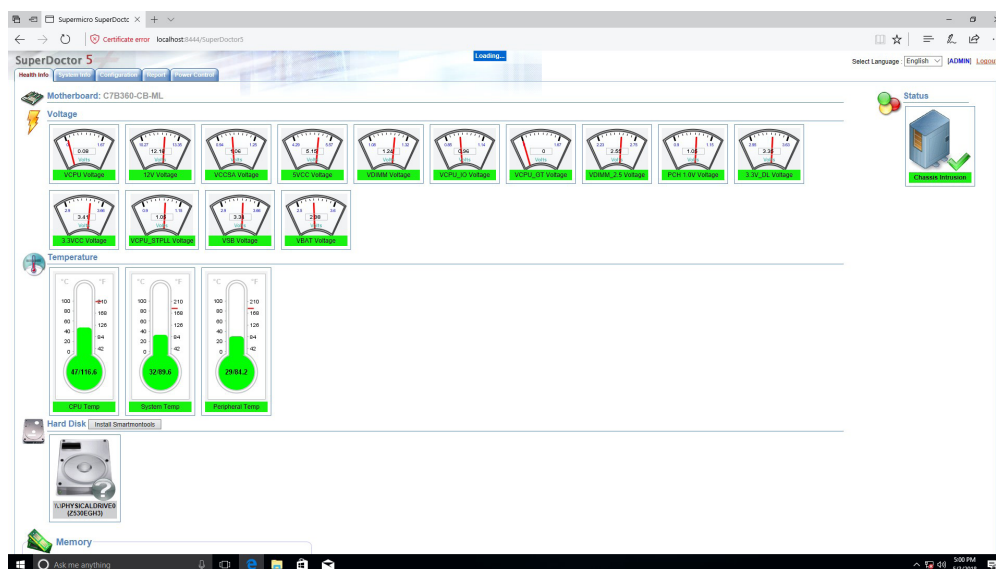

Figure B-2. SuperDoctor 5 Interface Display Screen (Health Information)



Note: The SuperDoctor 5 program and user's manual can be downloaded from the Supermicro website at http://www.supermicro.com/products/nfo/sms_sd5.cfm.

Appendix C

Standardized Warning Statements

The following statements are industry standard warnings, provided to warn the user of situations which have the potential for bodily injury. Should you have questions or experience difficulty, contact Supermicro's Technical Support department for assistance. Only certified technicians should attempt to install or configure components.

Read this section in its entirety before installing or configuring components.

These warnings may also be found on our website at http://www.supermicro.com/about/policies/safety_information.cfm.

Battery Handling



Warning! There is the danger of explosion if the battery is replaced incorrectly. Replace the battery only with the same or equivalent type recommended by the manufacturer. Dispose of used batteries according to the manufacturer's instructions

電池の取り扱い

電池交換が正しく行われなかった場合、破裂の危険性があります。交換する電池はメーカーが推奨する型、または同等のものを使用下さい。使用済電池は製造元の指示に従って処分して下さい。

警告

電池更換不當會有爆炸危險。請只使用同類電池或製造商推薦的功能相當的電池更換原有電池。請按製造商的說明處理廢舊電池。

警告

電池更換不當會有爆炸危險。請使用製造商建議之相同或功能相當的電池更換原有電池。請按照製造商的說明指示處理廢棄舊電池。

Warnung

Bei Einsetzen einer falschen Batterie besteht Explosionsgefahr. Ersetzen Sie die Batterie nur durch den gleichen oder vom Hersteller empfohlenen Batterietyp. Entsorgen Sie die benutzten Batterien nach den Anweisungen des Herstellers.

Attention

Danger d'explosion si la pile n'est pas remplacée correctement. Ne la remplacer que par une pile de type semblable ou équivalent, recommandée par le fabricant. Jeter les piles usagées conformément aux instructions du fabricant.

¡Advertencia!

Existe peligro de explosión si la batería se reemplaza de manera incorrecta. Reemplazar la batería exclusivamente con el mismo tipo o el equivalente recomendado por el fabricante. Desechar las baterías gastadas según las instrucciones del fabricante.

אזהרה!

קיימת סכנת פיצוץ של הסוללה במידה והוחלפה בדרך לא תקינה. יש להחליף את הסוללה בסוג התואם מחברת יצרן מומלצת. סילוק הסוללות המשומשות יש לבצע לפי הוראות היצרן.

هناك خطر من انفجار في حالة اسبدال البطارية بطريقة غير صحيحة فعلياً
اسبدال البطارية
فقط بنفس النوع أو ما يعادلها مما أوصت به الشركة المصنعة
جخلص من البطاريات المسعملة وفقاً لتعليمات الشركة الصانعة

경고!

배터리가 올바르게 교체되지 않으면 폭발의 위험이 있습니다. 기존 배터리와 동일하거나 제조사에서 권장하는 동등한 종류의 배터리로만 교체해야 합니다. 제조사의 안내에 따라 사용된 배터리를 처리하여 주십시오.

Waarschuwing

Er is ontploffingsgevaar indien de batterij verkeerd vervangen wordt. Vervang de batterij slechts met hetzelfde of een equivalent type die door de fabrikant aanbevolen wordt. Gebruikte batterijen dienen overeenkomstig fabrieksvoorschriften afgevoerd te worden.

Product Disposal



Warning! Ultimate disposal of this product should be handled according to all national laws and regulations.

製品の廃棄

この製品を廃棄処分する場合、国の関係する全ての法律・条例に従い処理する必要があります。

警告

本产品的废弃处理应根据所有国家的法律和规章进行。

警告

本產品的廢棄處理應根據所有國家的法律和規章進行。

Warnung

Die Entsorgung dieses Produkts sollte gemäß allen Bestimmungen und Gesetzen des Landes erfolgen.

¡Advertencia!

Al deshacerse por completo de este producto debe seguir todas las leyes y reglamentos nacionales.

Attention

La mise au rebut ou le recyclage de ce produit sont généralement soumis à des lois et/ou directives de respect de l'environnement. Renseignez-vous auprès de l'organisme compétent.

סילוק המוצר

אזהרה!

סילוק סופי של מוצר זה חייב להיות בהתאם להנחיות וחוקי המדינה.

عند التخلص النهائي من هذا المنتج ينبغي التعامل معه وفقا لجميع القوانين واللوائح الوطنية

경고!

이 제품은 해당 국가의 관련 법규 및 규정에 따라 폐기되어야 합니다.

Waarschuwing

De uiteindelijke verwijdering van dit product dient te geschieden in overeenstemming met alle nationale wetten en reglementen.

Appendix D

UEFI BIOS Recovery

Warning: Do not upgrade the BIOS unless your system has a BIOS-related issue. Flashing the wrong BIOS can cause irreparable damage to the system. In no event shall Supermicro be liable for direct, indirect, special, incidental, or consequential damages arising from a BIOS update. If you need to update the BIOS, do not shut down or reset the system while the BIOS is updating to avoid possible boot failure.

D.1 Overview

The Unified Extensible Firmware Interface (UEFI) provides a software-based interface between the operating system and the platform firmware in the pre-boot environment. The UEFI specification supports an architecture-independent mechanism that will allow the UEFI OS loader stored in an add-on card to boot the system. The UEFI offers clean, hands-off management to a computer during system boot.

D.2 Recovering the UEFI BIOS Image

A UEFI BIOS flash chip consists of a recovery BIOS block and a main BIOS block (a main BIOS image). The recovery block contains critical BIOS codes, including memory detection and recovery codes for the user to flash a healthy BIOS image if the original main BIOS image is corrupted. When the system power is turned on, the recovery block codes execute first. Once this process is complete, the main BIOS code will continue with system initialization and the remaining POST (Power-On Self-Test) routines.



Note 1: Follow the BIOS recovery instructions below for BIOS recovery when the main BIOS block crashes.

Note 2: When the BIOS recovery block crashes, you will need to follow the procedures to make a Returned Merchandise Authorization (RMA) request. (For a RMA request, please see section 3.5 for more information). Also, you may use the Supermicro Update Manager (SUM) Out-of-Band (OOB) (https://www.supermicro.com.tw/products/nfo/SMS_SUM.cfm) to reflash the BIOS.

D.3 Recovering the Main BIOS Block with a USB Device

This feature allows the user to recover the main BIOS image using a USB-attached device without additional utilities used. A USB flash device such as a USB Flash Drive, or a USB CD/DVD ROM device can be used for this purpose. However, a USB Hard Disk drive cannot be used for BIOS recovery at this time.

The file system supported by the recovery block is FAT (including FAT12, FAT16, and FAT32) which is installed on a bootable or non-bootable USB-attached device. However, the BIOS might need several minutes to locate the SUPER.ROM file if the media size becomes too large due to the huge volumes of folders and files stored in the device.

To perform UEFI BIOS recovery using a USB-attached device, follow the instructions below.

1. Using a different machine, copy the "Super.ROM" binary image file into the Root "\\" directory of a USB device or a writable CD/DVD.



Note 1: If you cannot locate the "Super.ROM" file in your drive disk, visit our website at www.supermicro.com to download the BIOS package. Extract the BIOS binary image into a USB flash device and rename it "Super.ROM" for the BIOS recovery use.

Note 2: Before recovering the main BIOS image, confirm that the "Super.ROM" binary image file you download is the same version or a close version meant for your motherboard.

2. Insert the USB device that contains the new BIOS image ("Super.ROM") into your USB drive and reset the system when the following screen appears.



- Press continuously during system boot to enter the BIOS Setup utility. From the top of the tool bar, select Boot to enter the submenu. From the submenu list, select Boot Option #1 as shown below. Then, set Boot Option #1 to [UEFI AP:UEFI: Built-in EFI Shell]. Press <F4> to save the settings and exit the BIOS Setup utility.

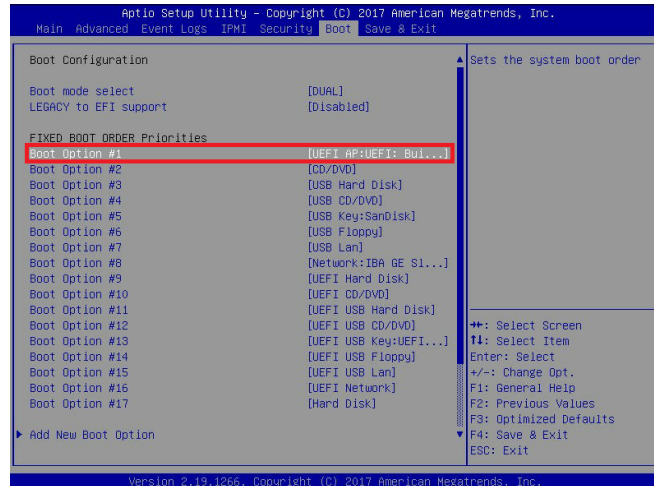

- When the UEFI Shell prompt appears, type fs# to change the device directory path. Go to the directory that contains the BIOS package you extracted earlier from Step 6. Enter flash.nsh BIOSname.### at the prompt to start the BIOS update process.



Note: Do not interrupt this process until the BIOS flashing is complete.

```

UEFI Interactive Shell v2.1
EDK II
UEFI v2.50 (American Megatrends, 0x0005000C)
Mapping table
FS0: Alias(s):HD0:0b::BLK1:
PcRoot(0x0)/Pci(0x14,0x0)/USB(0x11,0x0)/HD(1,MBR,0x37901D72,0x800,0x1
0A3592)
BLK0: Alias(s):
PcRoot(0x0)/Pci(0x14,0x0)/USB(0x11,0x0)
Press F8D in 1 seconds to skip startup.nsh or any other key to continue.
Shell: fs#
FS0:\>cd \EFI\SHS
FS0:\EFI\SHS> cd SKJPM2_03162017
FS0:\EFI\SHS\SKJPM2_03162017> flash.nsh X11DPU7.314
    
```

```

Done.
[ Access Cmos Port Ex ]
<read>
Index 0x51: 0x10
Done.
*****
* Program BIOS and ME (including FOT) regions...
*****
| AMI Firmware Update Utility v5.09.01.1317
| Copyright (C)2017 American Megatrends Inc. All Rights Reserved.
|-----|
CPUID = 50652
Reading flash ..... done
- ME Data Size checking - ok
- FFS checksums ..... ok
- Check RomLayout ..... Ok
Erasing Boot Block ..... done
Updating Boot Block ..... done
Verifying Boot Block ..... done
Erasing Main Block ..... 0x00132000 (0x)
    
```

- The screen below indicates that the BIOS update process is complete. When you see the screen below, unplug the AC power cable from the power supply, clear CMOS, and plug the AC power cable in the power supply again to power on the system.

```
Verifying NCB Block ..... done
- Update success for FDR
- Update success for IE
- Successful Update Recovery Loader to DPRx!!
- Successful Update #FSB!!
- Successful Update #IPW!!
- Successful Update #V81 and #V82!!
- Successful Update #LOS and #UTOK!!
- ME Entire Image update success !!
WARNING : System must power-off to have the changes take effect!
Moving FS0:\AFUDOS\SKJPME2_03162017\rdt464.efi -> FS0:\AFUDOS\SKJPME2_03162017\fdt464.smc
- [ok]
Moving FS0:\AFUDOS\SKJPME2_03162017\afuef1x64.efi -> FS0:\AFUDOS\SKJPME2_03162017\afuef1.smc
- [ok]
*****
* Please ignore this 'Shell: Cannot read from file - Device Error'
* warning message due to it does not impact flashing process.
*
*****
Deleting "FS0:\AFUDOS\SKJPME2_03162017\rdt464.efi"
Delete successful.
FS0:\>
```

- Press continuously to enter the BIOS Setup utility.
- Press <F3> to load the default settings.
- After loading the default settings, press <F4> to save the settings and exit the BIOS Setup utility.