



X12SDV-4C/8C/10C-SP6F
X12SDV-8CE-SP4F
X12SDV-10CR-SP6F

USER'S MANUAL

Revision 1.0a

The information in this user's manual has been carefully reviewed and is believed to be accurate. The manufacturer assumes no responsibility for any inaccuracies that may be contained in this document, and makes no commitment to update or to keep current the information in this manual, or to notify any person or organization of the updates. **Please Note: For the most up-to-date version of this manual, please see our website at www.supermicro.com.**

Super Micro Computer, Inc. ("Supermicro") reserves the right to make changes to the product described in this manual at any time and without notice. This product, including software and documentation, is the property of Supermicro and/or its licensors, and is supplied only under a license. Any use or reproduction of this product is not allowed, except as expressly permitted by the terms of said license.

IN NO EVENT WILL Super Micro Computer, Inc. BE LIABLE FOR DIRECT, INDIRECT, SPECIAL, INCIDENTAL, SPECULATIVE OR CONSEQUENTIAL DAMAGES ARISING FROM THE USE OR INABILITY TO USE THIS PRODUCT OR DOCUMENTATION, EVEN IF ADVISED OF THE POSSIBILITY OF SUCH DAMAGES. IN PARTICULAR, SUPER MICRO COMPUTER, INC. SHALL NOT HAVE LIABILITY FOR ANY HARDWARE, SOFTWARE, OR DATA STORED OR USED WITH THE PRODUCT, INCLUDING THE COSTS OF REPAIRING, REPLACING, INTEGRATING, INSTALLING OR RECOVERING SUCH HARDWARE, SOFTWARE, OR DATA.

Any disputes arising between manufacturer and customer shall be governed by the laws of Santa Clara County in the State of California, USA. The State of California, County of Santa Clara shall be the exclusive venue for the resolution of any such disputes. Supermicro's total liability for all claims will not exceed the price paid for the hardware product.

FCC Statement: This equipment has been tested and found to comply with the limits for a Class A digital device pursuant to Part 15 of the FCC Rules. These limits are designed to provide reasonable protection against harmful interference when the equipment is operated in a commercial environment. This equipment generates, uses, and can radiate radio frequency energy and, if not installed and used in accordance with the manufacturer's instruction manual, may cause harmful interference with radio communications. Operation of this equipment in a residential area is likely to cause harmful interference, in which case you will be required to correct the interference at your own expense.

California Best Management Practices Regulations for Perchlorate Materials: This Perchlorate warning applies only to products containing CR (Manganese Dioxide) Lithium coin cells. "Perchlorate Material-special handling may apply. See www.dtsc.ca.gov/hazardouswaste/perchlorate".



WARNING: This product can expose you to chemicals including lead, known to the State of California to cause cancer and birth defects or other reproductive harm. For more information, go to www.P65Warnings.ca.gov.

The products sold by Supermicro are not intended for and will not be used in life support systems, medical equipment, nuclear facilities or systems, aircraft, aircraft devices, aircraft/emergency communication devices or other critical systems whose failure to perform be reasonably expected to result in significant injury or loss of life or catastrophic property damage. Accordingly, Supermicro disclaims any and all liability, and should buyer use or sell such products for use in such ultra-hazardous applications, it does so entirely at its own risk. Furthermore, buyer agrees to fully indemnify, defend and hold Supermicro harmless for and against any and all claims, demands, actions, litigation, and proceedings of any kind arising out of or related to such ultra-hazardous use or sale.

Manual Revision 1.0a

Release Date: June 04, 2024

Unless you request and receive written permission from Super Micro Computer, Inc., you may not copy any part of this document. Information in this document is subject to change without notice. Other products and companies referred to herein are trademarks or registered trademarks of their respective companies or mark holders.

Copyright © 2024 by Super Micro Computer, Inc.
All rights reserved.

Printed in the United States of America

Preface

About This Manual

This manual is written for system integrators, IT technicians and knowledgeable end users. It provides information for the installation and use of the motherboard.

About This Motherboard

The Supermicro X12SDV-4C/8C/10C-SP6F, X12SDV-8CE-SP4F and X12SDV-10CR-SP6F series motherboards are built with the Intel® Xeon® D-1700 series and Intel Xeon D-1800 series processors with up to 10 cores and a thermal design power (TDP) of up to 80 W (Intel Xeon D-1700) or 55 W (Intel Xeon D-1800). These motherboards feature high performance and low power consumption in a small form factor motherboards. They support 256 GB ECC and Non-ECC RDIMM/UDIMM DDR4 memory with speeds of up to 2933 MT/s, two SATA 3.0 ports, one PCIe 4.0 x16 slot or two PCIe 4.0 x8 slots, and three M.2 slots (one M-Key, one B-Key, one E-Key). The Supermicro X12SDV-4C/8C/10C-SP6F and X12SDV-10CR-SP6F series motherboards feature six LAN ports including two 25 GbE ports and four GbE ports. The Supermicro X12SDV-8CE-SP4F motherboard is designed to support extended working temperatures with two 25 GbE ports and two GbE ports. These motherboards also feature onboard Trusted Platform Module (TPM) 2.0 headers for hardware-based security function support. Note that this motherboard is intended to be installed and serviced by professional technicians only. For processor/memory updates, refer to our website at <http://www.supermicro.com/products/>.

Conventions Used in the Manual

Special attention should be given to the following symbols for proper installation and to prevent damage done to the components or injury to yourself:



Warning! Indicates important information given to prevent equipment/property damage or personal injury.



Warning! Indicates high voltage may be encountered while performing a procedure.



Important: Important information given to ensure proper system installation or to relay safety precautions.



Note: Additional Information given to differentiate various models or to provide information for proper system setup.

Contacting Supermicro

Headquarters

Address: Super Micro Computer, Inc.
980 Rock Ave.
San Jose, CA 95131 U.S.A.

Tel: +1 (408) 503-8000

Fax: +1 (408) 503-8008

Email: marketing@supermicro.com (General Information)
Sales-USA@supermicro.com (Sales Inquiries)
Government_Sales-USA@supermicro.com (Gov. Sales Inquiries)
support@supermicro.com (Technical Support)
RMA@supermicro.com (RMA Support)
Webmaster@supermicro.com (Webmaster)

Website: www.supermicro.com

Europe

Address: Super Micro Computer B.V.
Het Sterrenbeeld 28, 5215 ML
's-Hertogenbosch, The Netherlands

Tel: +31 (0) 73-6400390

Fax: +31 (0) 73-6416525

Email: Sales_Europe@supermicro.com (Sales Inquiries)
Support_Europe@supermicro.com (Technical Support)
RMA_Europe@supermicro.com (RMA Support)

Website: www.supermicro.nl

Asia-Pacific

Address: Super Micro Computer, Inc.
3F, No. 150, Jian 1st Rd.
Zhonghe Dist., New Taipei City 235
Taiwan (R.O.C)

Tel: +886-(2) 8226-3990

Fax: +886-(2) 8226-3992

Email: Sales-Asia@supermicro.com.tw (Sales Inquiries)
Support@supermicro.com.tw (Technical Support)
RMA@supermicro.com.tw (RMA Support)

Website: www.supermicro.com.tw

Table of Contents

Chapter 1 Introduction

1.1 Checklist	8
Quick Reference	12
Quick Reference Table	14
Motherboard Features	16
1.2 Processor and Chipset Overview	19
1.3 Special Features	19
Recovery from AC Power Loss	19
1.4 System Health Monitoring	20
Onboard Voltage Monitors	20
Fan Status Monitor with Firmware Control	20
Environmental Temperature Control	20
System Resource Alert	20
1.5 ACPI Features	21
1.6 Power Supply	21
1.7 Serial Port	21

Chapter 2 Installation

2.1 Static-Sensitive Devices	22
Precautions	22
Unpacking	22
2.2 Motherboard Installation	23
Tools Needed	23
Location of Mounting Holes	23
Installing the Motherboard	24
2.3 Memory Support and Installation	25
Memory Support	25
General Guidelines for Optimizing Memory Performance	26
DIMM Installation	27
DIMM Removal	27
2.4 Rear I/O Ports	28
2.5 Front Control Panel	32

2.6 Connectors	37
Power Connections	37
Headers	39
2.7 Jumper Settings	50
How Jumpers Work.....	50
2.8 LED Indicators.....	56

Chapter 3 Troubleshooting

3.1 Troubleshooting Procedures	59
Before Power On	59
No Power	59
No Video	60
System Boot Failure.....	60
Memory Errors	60
Losing the System's Setup Configuration.....	61
When the System Becomes Unstable	61
3.2 Technical Support Procedures	63
3.3 Frequently Asked Questions	64
3.4 Battery Removal and Installation	65
Battery Removal.....	65
Proper Battery Disposal	65
Battery Installation.....	65
3.5 Returning Merchandise for Service.....	66

Chapter 4 UEFI BIOS

4.1 Introduction.....	67
4.2 Main Setup	68
4.3 Advanced.....	70
4.4 Event Logs	105
4.5 BMC.....	107
4.6 Security.....	110
4.7 Boot	115
4.8 Save & Exit.....	117

Appendix A BIOS Codes

Appendix B Software

Appendix C Standardized Warning Statements

Appendix D UEFI BIOS Recovery

Chapter 1

Introduction

Congratulations on purchasing your computer motherboard from an industry leader. Supermicro motherboards are designed to provide you with the highest standards in quality and performance.

In addition to the motherboard, several important parts that are included in the retail box are listed below. If anything listed is damaged or missing, contact your retailer.

1.1 Checklist

Retail Packaging Parts List		
Description	Part Number	Quantity
Supermicro Motherboard	X12SDV-4C/8C/10C-SP6F, X12SDV-8CE-SP4F, or X12SDV-10CR-SP6F	1
I/O Shield	MCP-260-00098-0N	1
SATA Cables	CBL-0044L	2
SlimSAS to U.2 Cables	CBL-SAST-1240A-85	2
COM Port Cable	CBL-CDAT-0605	1
Quick Reference Guide	MNL-2362-QRG	1

Important Links

For your system to work properly, follow the links below to download all necessary drivers/utilities and the user's manual for your server.

- Supermicro product manuals: <http://www.supermicro.com/support/manuals/>
- Product drivers and utilities: <https://www.supermicro.com/wdl/driver/>
- Product safety info: http://www.supermicro.com/about/policies/safety_information.cfm
- A secure data deletion tool designed to fully erase all data from storage devices can be found at our website: https://www.supermicro.com/about/policies/disclaimer.cfm?url=/wftp/utility/Lot9_Secure_Data_Deletion_Utility/
- If you have any questions, contact our support team at: support@supermicro.com

This manual may be periodically updated without notice. Check the Supermicro website for possible updates to the manual revision level.

Figure 1-1. X12SDV-4C/8C/10C-SP6F Motherboard Image

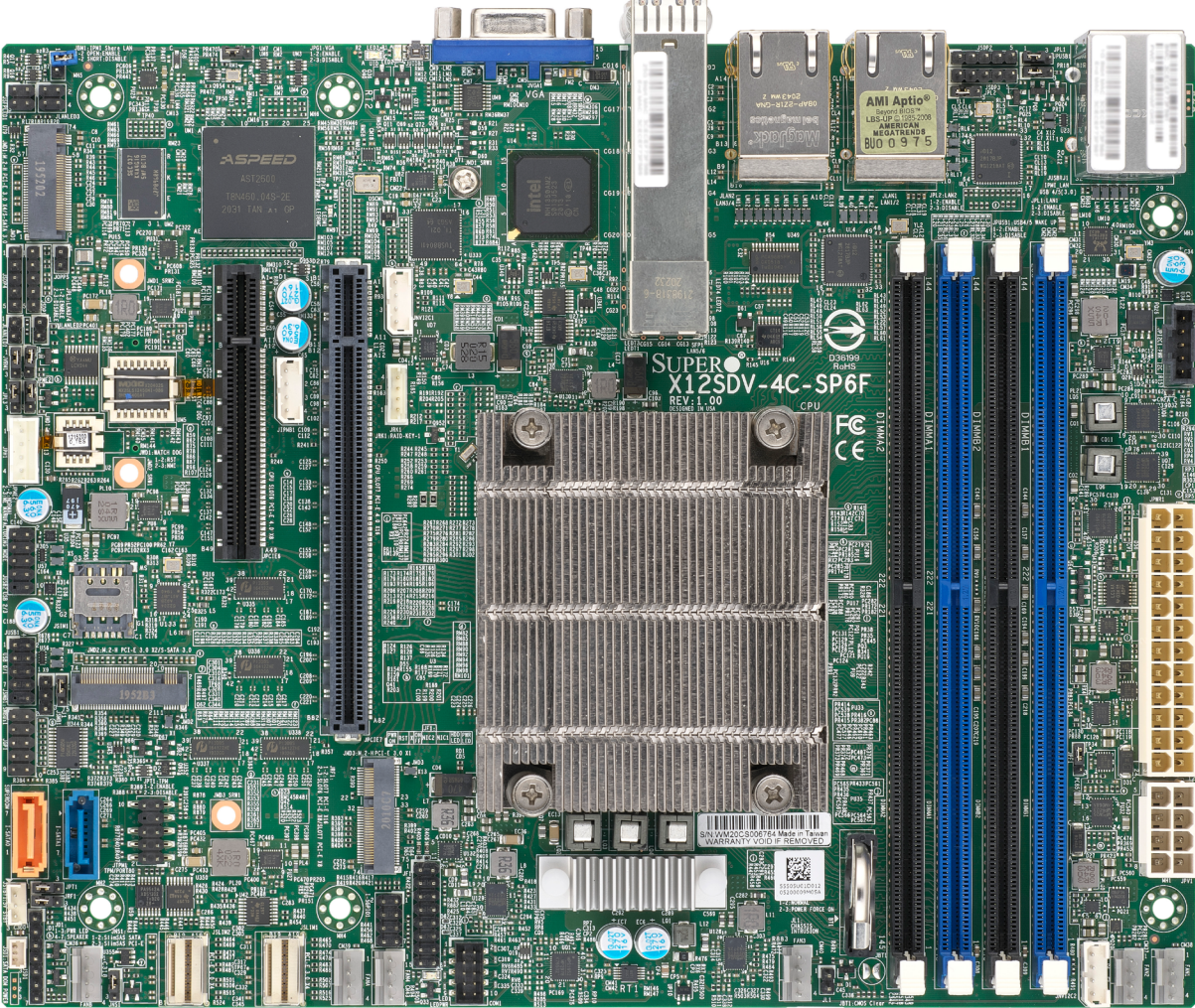

Note: All graphics shown in this manual were based upon the latest PCB revision available at the time of publication of the manual. The motherboard you received may or may not look exactly the same as the graphics shown in this manual.

Figure 1-1. X12SDV-8CE-SP4F Motherboard Image

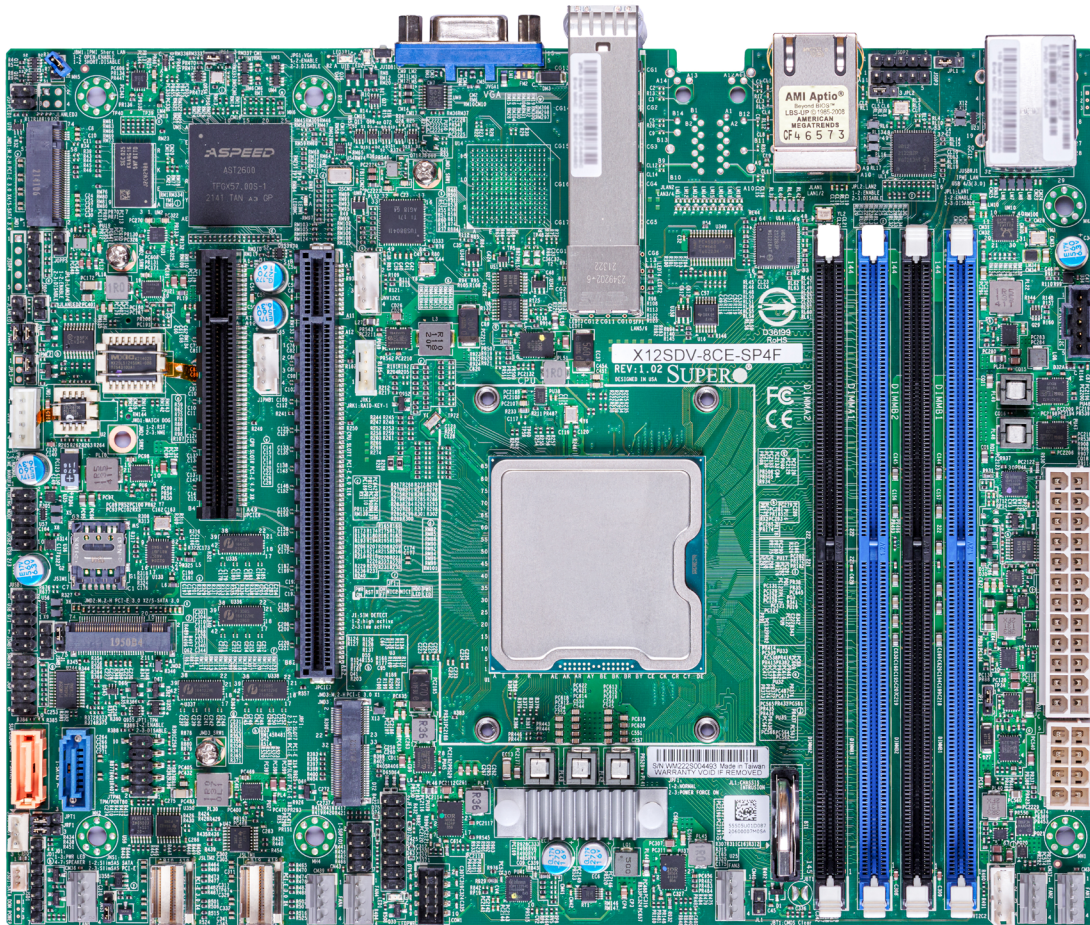

Note: All graphics shown in this manual were based upon the latest PCB revision available at the time of publication of the manual. The motherboard you received may or may not look exactly the same as the graphics shown in this manual.

**Figure 1-2. X12SDV-4C/8C/10C-SP6F, X12SDV-8CE-SP4F, X12SDV-10CR-SP6F
Motherboard Layout**
(not drawn to scale)

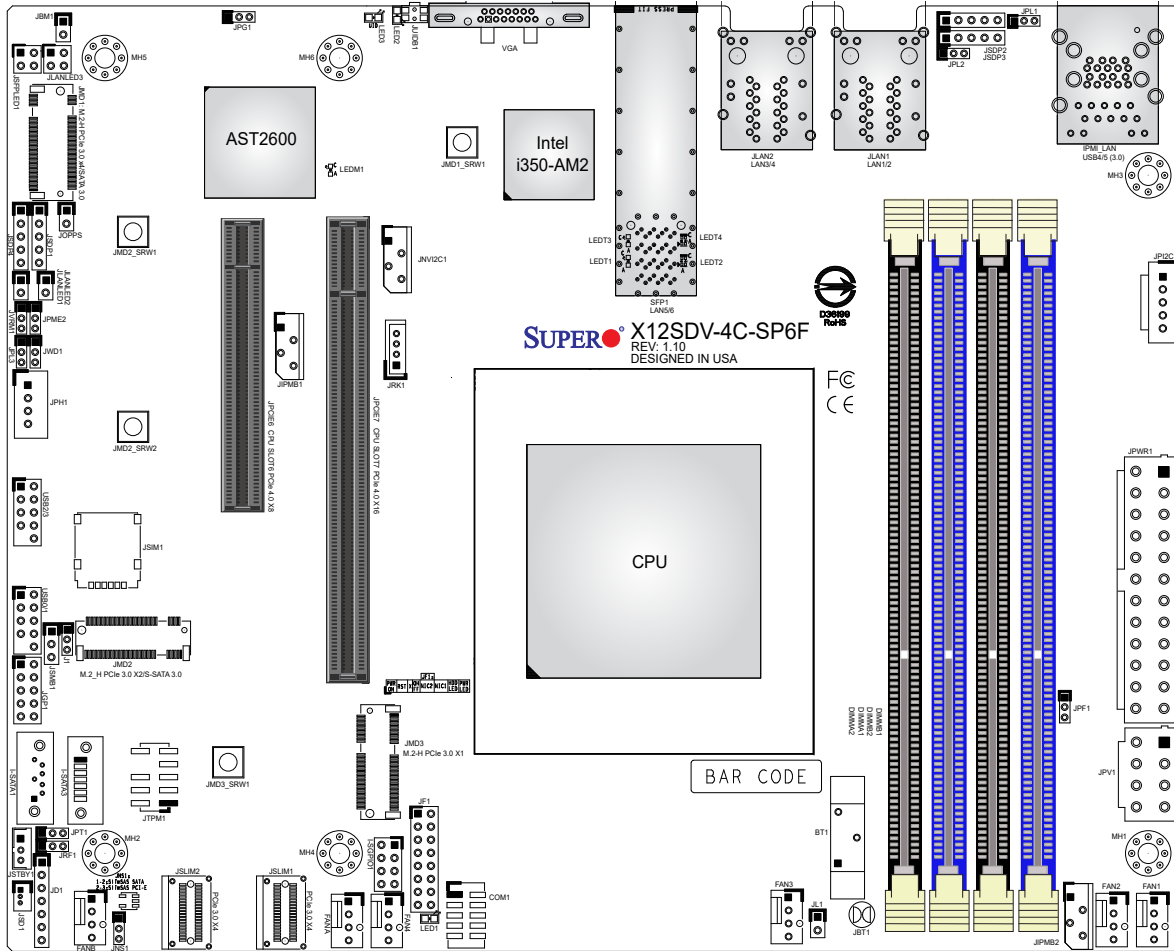

Note: Components not documented are for internal testing only.

Quick Reference

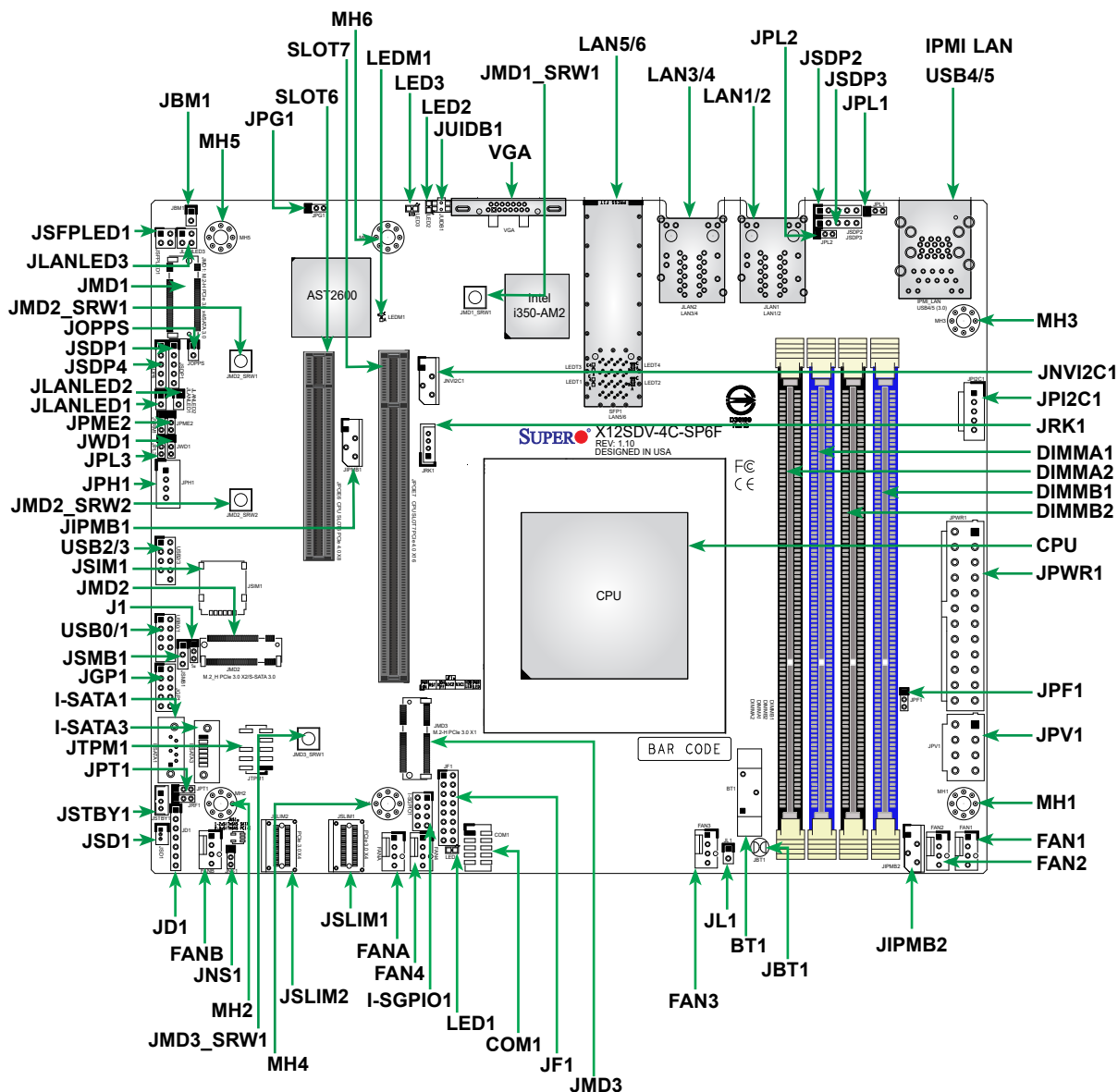

Notes:

- See [Chapter 2](#) for detailed information on jumpers, I/O ports, and JF1 front panel connections.
- "■" indicates the location of Pin 1.
- Jumpers/LEDs not indicated are used for testing only.
- Use only the correct type of onboard CMOS battery as specified by the manufacturer. Do not install the onboard battery upside down to avoid possible explosion.

Figure 1-3. Motherboard Model Variation Table

X12SDV-4C/8C/10C-SP6F, X12SDV-8CE-SP4F and X12SDV-10CR-SP6F Variations					
Motherboard Model	X12SDV-4C-SP6F	X12SDV-8C-SP6F	X12SDV-8CE-SP4F	X12SDV-10C-SP6F	X12SDV-10CR-SP6F
Processor Name	D-1718T	D-1736NT	D-1732TE	D-1747NTE	D-1844NT
Number of Cores	4	8	8	10	10
Cache	10 MB	15 MB	15 MB	15 MB	15 MB
Processor TDP	46 W	67 W	52 W	80 W	55 W
Processor Base Frequency	2.6 GHz	2.7 GHz	1.9 GHz	2.5 GHz	2.0 GHz
Intel Turbo Boost Technology	Yes	Yes	Yes	Yes	Yes
Number of Memory Channels	2	2	2	2	2
Max Memory Operating Speed	2933 MT/s	2667 MT/s	2667 MT/s	2933 MT/s	2667 MT/s
Intel QuickAssist Technology	No	Yes	No	Yes	Yes
Intel Virtualization Technology (VT-x)	Yes	Yes	Yes	Yes	Yes
Intel Virtualization Technology for Directed I/O (VT-d)	Yes	Yes	Yes	Yes	Yes
CPU Heatsink with FAN	No	No	No CPU Heatsink	No	No
Motherboard Operating Temperature	0°C – 60°C (32°F – 40°F)	0°C – 60°C (32°F – 40°F)	-40°C – 60°C (-40°F – 40°F)	0°C – 60°C (32°F – 40°F)	0°C – 60°C (32°F – 40°F)

Quick Reference Table

Jumper	Description	Default Setting
J1	SIM Card Detection	Pins 1-2 (High Active)
JBM1	IPMI Shared LAN Enable/Disable	Open (Enabled)
JBT1	CMOS Clear	Open (Normal)
JNS1	SlimSAS Interface Selection	Pins 2-3 (PCIe x4)
JPF1	Power Force On	Pins 1-2 (ATX)
JPG1	VGA Enable/Disable	Pins 1-2 (Enabled)
JPL1, JPL2, JPL3	LAN1, LAN2, LAN3/4 Enable	Pins 1-2 (Enabled)
JPME2	ME Manufacturing Mode	Pins 1-2 (Normal)
JPT1	Onboard TPM 2.0 Enable/Disable	Pins 1-2 (Enabled)
JWD1	Watchdog Timer	Pins 1-2 (Reset)
LED	Description	Status
LED1	Power LED	Solid Green: Power On
LED2	UID LED	Solid Blue: Unit Identified
LED3	Overheat (OH)/Power Fail/Fan Fail LED	Solid Red: Overheat Blinking Red: Power Fail or Fan Fail
LEDM1	BMC Heartbeat LED	Blinking Green: BMC Normal
Connector	Description	
BT1	Onboard Battery	
COM1	COM Header	
FAN1 – FAN4, FANA, FANB	CPU/System Fan Headers (FAN1: CPU Fan)	
IPMI LAN	Dedicated IPMI LAN Port	
I-SATA1 and I-SATA3	SATA 3.0 Ports (I-SATA1: SATA DOM Power)	
I-SGPIO1	Serial Link General Purpose I/O Header	
JD1	Power LED/Speaker (Pins 1-3: Power LED, Pins 4-7: Speaker)	
JF1	Front Control Panel Header	
JGP1	General Purpose I/O Header	
JIPMB1, JIPMB2	4-pin BMC External I2C Headers	
JL1	Chassis Intrusion Header	
JLANLED1	LAN1 Activity LED Header	
JLANLED2	LAN2 Activity LED Header	
JLANLED3	LAN3/4 Activity LED Header	
JMD1	M.2 M-Key 2280 PCIe 3.0 x4 or SATA 3.0 Slot	
JMD2	M.2 B-Key 2280/3042/3052 PCIe 3.0 x2 or SATA 3.0 or USB 3.0 Slot	
JMD3	M.2 E-Key 2230 PCIe 3.0 x1 or USB 2.0 Slot	



Note: Table is continued on the next page.

Connector	Description
JMD1_SRW1, JMD2_SRW1, JM2_SRW2, JMD3_SRW1	M.2 Mounting Holes
JNVI2C1	Non-Volatile Memory (NVMe) I2C Header
JOPPS	Reserved for One Pulse Per Second
JPH1	4-pin HDD Power Connector
JPI2C1	Power System Management (SMB) I2C Header
JPWR1	24-pin ATX Power Connector
JPV1	8-pin 12 V DC Power Connector for CPU (Required) or alternate single power input for when the 24-pin ATX power is not in use
JRK1	Intel RAID Key Header
JSD1	SATA DOM Power Connector
JSDP1 – JSDP4	Reserved for time synchronization
JSFPLED1	LAN5/6 Activity LED header
JSIM1	NANO SIM Slot for M.2 B-key
JSLIM1, JSLIM2	SlimSAS PCIe 3.0 x4 Slots
JSMB1	System Management Bus Header
JSTBY1	Standby Power Header
JTPM1	Trusted Platform Module (TPM)/Port 80 Connector
JUIDB1	Unit Identifier Switch
LAN1/2, LAN3/4	Gigabit Ethernet RJ45 Ports
LAN5/6	25 GbE SFP28 LAN Ports
MH1 – MH6	Motherboard Mounting Holes
SLOT6	CPU SLOT6 PCIe 4.0 x8
SLOT7	CPU SLOT7 PCIe 4.0 x16
USB0/1, USB2/3	USB 2.0 Headers
USB4/5	Rear I/O USB 3.0 Ports
VGA	VGA Port

Motherboard Features

Motherboard Features	
CPU	
<ul style="list-style-type: none"> Supports an Intel Xeon D-1700 series processor with a thermal design power (TDP) of up to 80 W or an Intel Xeon D-1800 series processor with a TDP of up to 55 W. 	
Chipset	
<ul style="list-style-type: none"> System on Chip 	
Memory	
<ul style="list-style-type: none"> Up to 256 GB of ECC and Non-ECC RDIMM/UDIMM DDR4 memory with speeds of up to 2933 MT/s in four memory slots 	
DIMM Size	
<ul style="list-style-type: none"> 8, 16, 32, 64 GB. 	
 Note: For the latest CPU/memory updates, refer to our website at http://www.supermicro.com/products/motherboard .	
Expansion Slots	
<ul style="list-style-type: none"> One PCIe 4.0 x16 Slot (x16 SLOT7) or two PCIe 4.0 x8 Slots (x8 SLOT6, x8 SLOT7) One M.2 M-Key 2280 PCIe 3.0 x4 or SATA 3.0 Slot One M.2 B-Key 2280/3042/3052 PCIe 3.0 x2 or SATA 3.0 or USB 3.0 Slot One M.2 E-Key 2230 PCIe 3.0 x1 or USB 2.0 Slot Two PCIe 3.0 x4 SlimSAS Connectors 	
Network	
<ul style="list-style-type: none"> Intel I350-AM2 for two GbE ports (-SP6F only) Intel I210-IT for two GbE ports Integrated Ethernet Controller in processor for 25 GbE SFP28 ports 	
Baseboard Management Controller (BMC)	
<ul style="list-style-type: none"> Aspeed AST2600 BMC 	
Graphics	
<ul style="list-style-type: none"> Aspeed AST2600 	
I/O Devices	
<ul style="list-style-type: none"> Serial (COM) Port SATA 3.0 Video (VGA) Port 	<ul style="list-style-type: none"> One serial port header (COM1) Two SATA 3.0 ports (I-SATA1, I-SATA3) One VGA connection on the rear I/O panel



Note: The table above is continued on the next page.

Motherboard Features

Peripheral Devices

- Two USB 3.0 ports on the rear I/O panel (USB4/5)
- Two front accessible USB 2.0 headers with two USB connections (USB0/1, USB2/3)

BIOS

- 256 Mb AMI BIOS® SPI Flash BIOS
- ACPI 6.0, Plug and Play (PnP), Riser Card Detection, and SMBIOS 3.0 or later

Power Management

- ACPI power management
- Power button override mechanism
- Power-on mode for AC power recovery
- Wake-on-LAN

System Health Monitoring

- Onboard voltage monitoring for +12 V, +5 V, +3.3 V, CPU, Memory, VBAT, +3.3 V stdby, CPU temperature, PCH temperature, system temperature
- 3 CPU switch phase voltage regulator
- CPU thermal trip support
- Platform Environment Control Interface (PECI)/TSI

Fan Control

- Fan status monitoring
- Dual cooling zone
- Six 4-pin fan headers

System Management

- Trusted Platform Module (TPM) support
- SuperDoctor® 5
- Chassis intrusion header and detection

LED Indicators

- Overheat (OH)/Fan Fail/Power Fail LED
- UID/remote LED
- Power indicator LED
- BMC Heartbeat LED
- LAN activity LED

Dimensions

- 9" (W) x 7.25" (L) Flex ATX (228.6mm x 184.15mm)



Note: The CPU maximum thermal design power (TDP) is subject to chassis and heatsink cooling restrictions. For proper thermal management, check the chassis and heatsink specifications for proper CPU TDP sizing.

Figure 1-4.
System Block Diagram

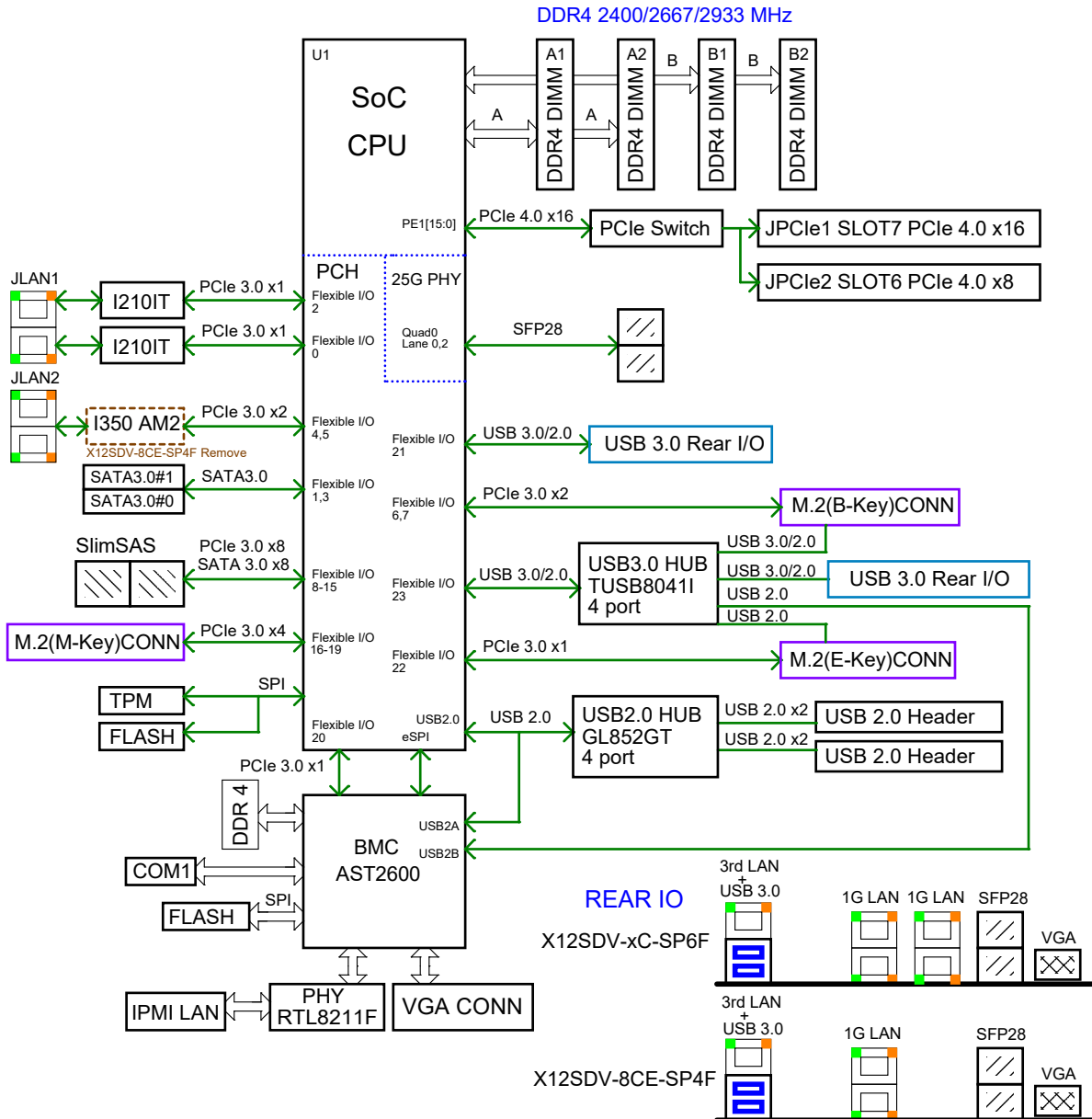

Note: This is a general block diagram and may not exactly represent the features on your motherboard. See the previous pages for the actual specifications of your motherboard.

1.2 Processor and Chipset Overview

Built upon the functionality and capability of the Intel Xeon D-1700 series and Intel Xeon D-1800 series processors, the X12SDV-4C/8C/10C-SP6F, X12SDV-8CE-SP4F, and X12SDV-10CR-SP6F motherboards provide system performance, power efficiency, and feature sets to address the needs of next-generation computer users.

The X12SDV-4C/8C/10C-SP6F, X12SDV-8CE-SP4F and X12SDV-10CR-SP6F motherboards dramatically increase system performance for a multitude of server applications.

The motherboard provides the following features:

- Intel TXT, and AMT vPro
- USB 3.0, SATA 3.0
- Intel Hyper-Threading, Intel VT-D, VT-x
- TSX-NI, AES, SGX
- Intel Turbo Boost Technology
- Intel Rapid Storage Technology
- 256 GB ECC and Non-ECC RDIMM/UDIMM DDR4 memory support with speeds of up to 2933 MT/s

1.3 Special Features

Recovery from AC Power Loss

The Basic I/O System (BIOS) provides a setting that determines how the system will respond when AC power is lost and then restored to the system. You can choose for the system to remain powered off (in which case you must press the power switch to turn it back on), or for it to automatically return to the power-on state. See the Advanced BIOS Setup section for this setting. The default setting is **Last State**.

1.4 System Health Monitoring

Onboard Voltage Monitors

The onboard voltage monitor will continuously scan crucial voltage levels. Once a voltage becomes unstable, a warning is given, or an error message is sent to the screen. You can adjust the voltage thresholds to define the sensitivity of the voltage monitor.

Fan Status Monitor with Firmware Control

The system health monitor chip can check the RPM status of a cooling fan. The CPU and chassis fans are controlled by the BIOS Thermal Management.

Environmental Temperature Control

The thermal control sensor monitors the CPU temperature in real time and will turn on the thermal control fan whenever the CPU temperature exceeds a user-defined threshold. The overheat circuitry runs independently from the CPU. Once the thermal sensor detects that the CPU temperature is too high, it will automatically turn on the thermal fans to prevent the CPU from overheating. The onboard chassis thermal circuitry can monitor the overall system temperature and alert you when the chassis temperature is too high.



Note: To avoid possible system overheating, provide adequate airflow to your system.

System Resource Alert

This feature is available when used with SuperDoctor 5® in the Windows OS or in the Linux environment. SuperDoctor is used to notify you of certain system events. For example, you can configure SuperDoctor to provide you with warnings when the system temperature, CPU temperatures, voltages and fan speeds go beyond a predefined range.

1.5 ACPI Features

The Advanced Configuration and Power Interface (ACPI) specification defines a flexible and abstract hardware interface that provides a standard way to integrate power management features throughout a computer system, including its hardware, operating system and application software. This enables the system to automatically turn on and off peripherals such as CD-ROMs, network cards, hard disk drives and printers.

In addition to enabling operating system-directed power management, ACPI also provides a generic system event mechanism for Plug and Play, and an operating system-independent interface for configuration control. ACPI leverages the Plug and Play BIOS data structures, while providing a processor architecture-independent implementation that is compatible with appropriate Windows operating systems. For detailed information regarding OS support, refer to the Supermicro website.

1.6 Power Supply

As with all computer products, a stable power source is necessary for proper and reliable operation. It is even more important for processors that have high CPU clock rates where noisy power transmission is present.

The X12SDV-4C/8C/10C-SP6F, X12SDV-8CE-SP4F, and X12SDV-10CR-SP6F motherboards accommodate a 24-pin ATX power supply. Although most power supplies generally meet the specifications required by the CPU, some are inadequate. The 8-pin connector is for 12 V DC input. It can work without the 24-pin ATX power connector.

It is strongly recommended that you use a high quality power supply that meets ATX power supply Specification 2.02 or above.

1.7 Serial Port

The X12SDV-4C/8C/10C-SP6F, X12SDV-8CE-SP4F, and X12SDV-10CR-SP6F motherboards support one serial communication connection. The UART provides legacy speeds with a baud rate of up to 115.2 Kbps.

Chapter 2

Installation

2.1 Static-Sensitive Devices

Electrostatic Discharge (ESD) can damage electronic components. To avoid damaging your system board, it is important to handle it very carefully. The following measures are generally sufficient to protect your equipment from ESD.

Precautions

- Use a grounded wrist strap designed to prevent static discharge.
- Touch a grounded metal object before removing the board from the antistatic bag.
- Handle the motherboard by its edges only; do not touch its components, peripheral chips, memory modules or gold contacts.
- When handling chips or modules, avoid touching their pins.
- Put the motherboard and peripherals back into their antistatic bags when not in use.
- For grounding purposes, make sure that your computer chassis provides excellent conductivity between the power supply, the case, the mounting fasteners and the motherboard.
- Use only the correct type of onboard CMOS battery. Do not install the onboard battery upside down to avoid possible explosion.

Unpacking

The motherboard is shipped in antistatic packaging to avoid static damage. When unpacking the motherboard, make sure that the person handling it is static protected.

2.2 Motherboard Installation

All motherboards have standard mounting holes to fit different types of chassis. Make sure that the locations of all the mounting holes for both the motherboard and the chassis match. Although a chassis may have both plastic and metal mounting fasteners, metal ones are highly recommended because they ground the motherboard to the chassis. Make sure that the metal standoffs click in or are screwed in tightly.

Tools Needed

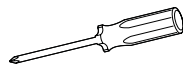

**Phillips
Screwdriver
(1)**



**Phillips Screws
(6)**



**Standoffs (6)
Only if Needed**

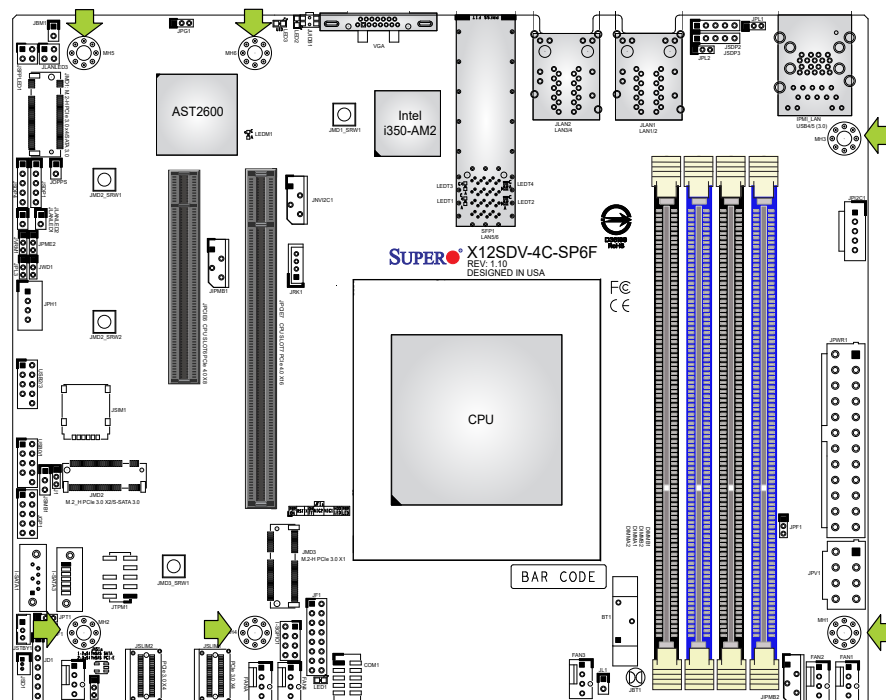

Location of Mounting Holes



Note 1: To avoid damaging the motherboard and its components, do not use a force greater than 8 lbf-in on each mounting screw during motherboard installation.



Note 2: Some components are very close to the mounting holes. Take precautionary measures to avoid damaging these components when installing the motherboard to the chassis.

Installing the Motherboard

1. Install the I/O shield into the back of the chassis, if applicable.

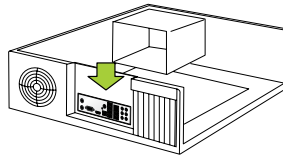

2. Locate the mounting holes on the motherboard. See the previous page for the location.

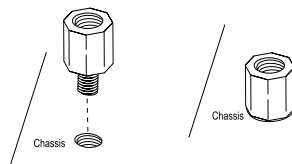

3. Locate the matching mounting holes on the chassis. Align the mounting holes on the motherboard against the mounting holes on the chassis.

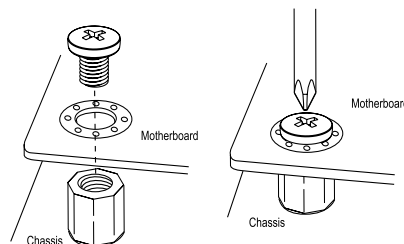

4. Install standoffs in the chassis as needed.
5. Install the motherboard into the chassis carefully to avoid damaging other motherboard components.
6. Using the Phillips screwdriver, insert a pan head #6 screw into a mounting hole on the motherboard and its matching mounting hole on the chassis.
7. Repeat step 6 to insert #6 screws into all mounting holes.
8. Make sure that the motherboard is securely placed in the chassis.

 **Note:** Images displayed are for illustration only. Your chassis or components might look different from those shown in this manual.

2.3 Memory Support and Installation



Note: Check the Supermicro website for recommended memory modules.



Important: Exercise extreme care when installing or removing DIMM modules to prevent any possible damage.

Memory Support

The X12SDV-4C/8C/10C-SP6F, X12SDV-8CE-SP4F and X12SDV-10CR-SP6F motherboards support up to 256 GB of ECC and Non-ECC RDIMM/UDIMM DDR4 memory with speeds of up to 2933 MT/s in four memory slots.

Recommended Population (Balanced)				
DIMMA1	DIMMB1	DIMMA2	DIMMB2	Total System Memory
4 GB	4 GB			8 GB
4 GB	4 GB	4 GB	4 GB	16 GB
8 GB	8 GB			16 GB
8 GB	8 GB	8 GB	8 GB	32 GB
16 GB	16 GB			32 GB
16 GB	16 GB	16 GB	16 GB	64 GB
32 GB	32 GB			64 GB
32 GB	32 GB	32 GB	32 GB	128 GB
64 GB	64 GB			128 GB
64 GB	64 GB	64 GB	64 GB	256 GB

General Guidelines for Optimizing Memory Performance

- It is recommended to use DDR4 memory of the same type, size, and speed.
- Mixed DIMM speeds can be installed. However, all DIMMs will run at the speed of the slowest DIMM.
- The motherboard will support odd-numbered modules (one or three modules installed). For one DIMM installation, use the blue slot. However, to achieve the best memory performance, a balanced memory population is recommended.

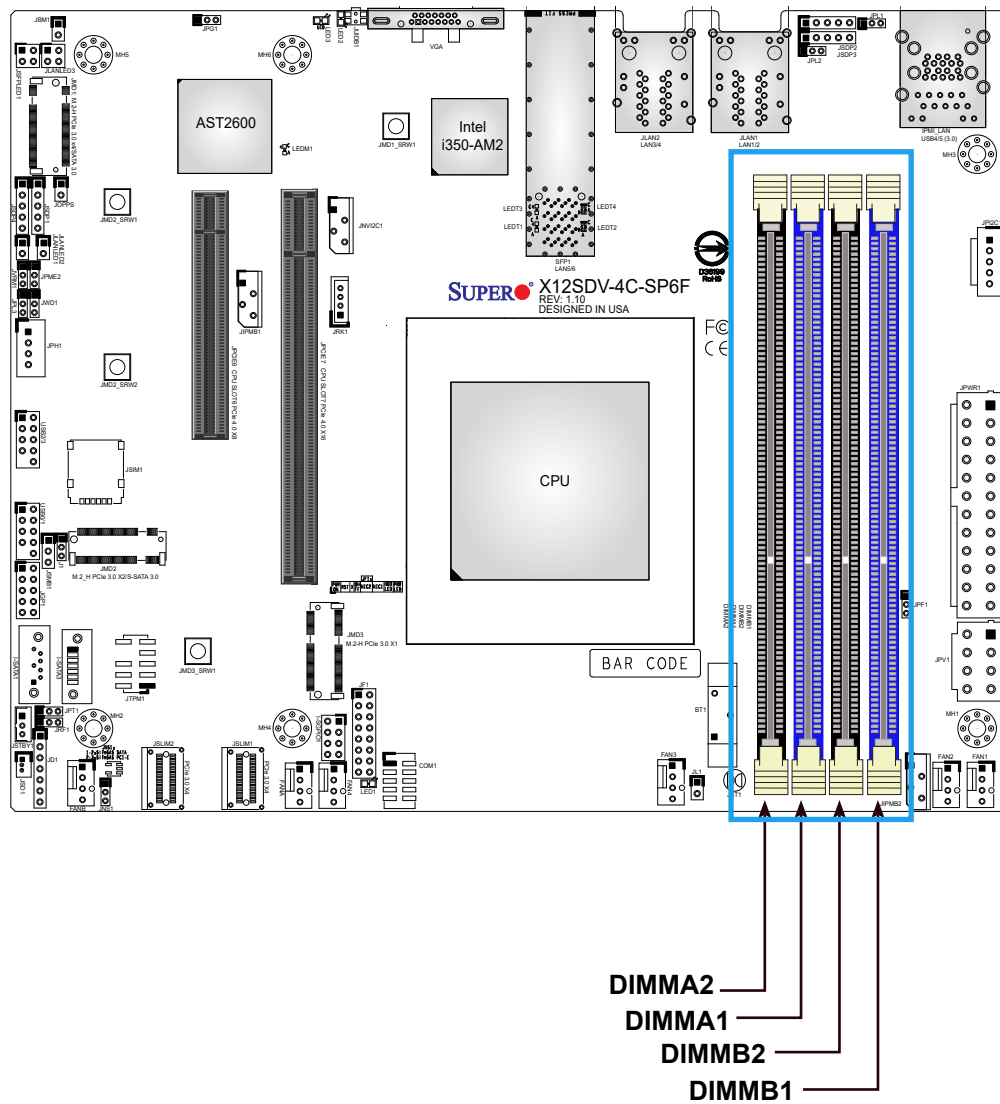

DIMM Installation

1. Insert DIMM modules in the following order: DIMMA1, DIMMB1, then DIMMA2, DIMMB2. For the system to work properly, use memory modules of the same type and speed.
2. Align the DIMM module key with the receptive point on the single-latch DIMM slot.
3. Push the release tab outwards to unlock the slot.
4. Align the notch on the end of the module against the receptive point on the end of the slot.
5. Press both ends of the module straight down into the slot until the module snaps into place.
6. Push the release tab to the lock position to secure the module into the slot.

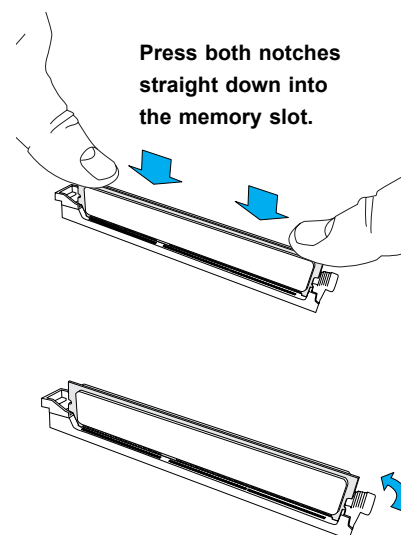
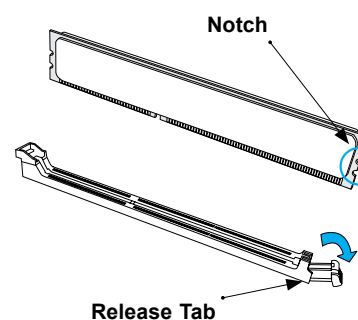
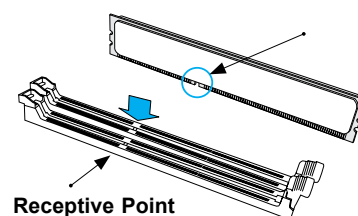
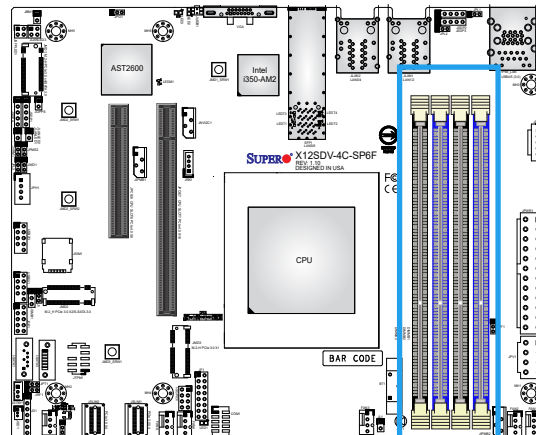

DIMM Removal

Press the release tab on one end of the DIMM module to unlock it. Once the DIMM module is loosened, remove it from the memory slot.

2.4 Rear I/O Ports

See Figure 2-1 below for the locations and descriptions of the various I/O ports on the rear of the motherboard.

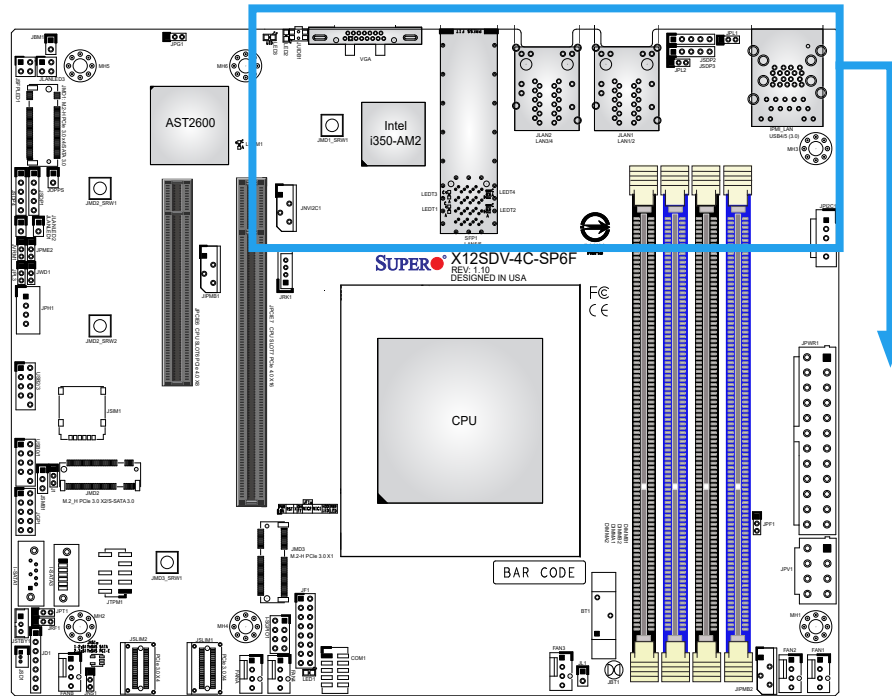
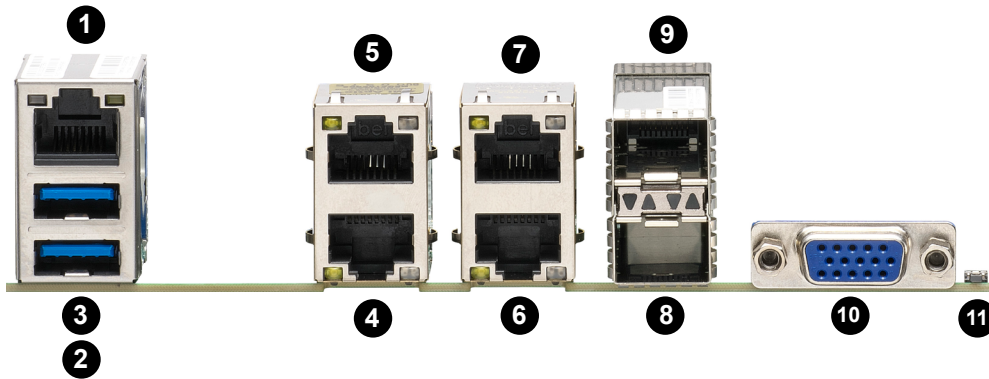

Figure 2-1. I/O Port Locations and Definitions



Rear I/O Ports					
#	Description	#	Description	#	Description
1	IPMI LAN	6	RJ45 LAN3	11	UID Button
2	USB4 (3.0)	7	RJ45 LAN4		
3	USB5 (3.0)	8	SFP28 LAN5		
4	RJ45 LAN1	9	SFP28 LAN6		
5	RJ45 LAN2	10	VGA Port		



Note: RJ45 LAN3 and RJ45 LAN4 are unavailable on X12SDV-8CE-SP4F.

VGA Port

A video (VGA) port is located on the rear I/O panel. Refer to the board layout below for the location.

LAN Ports

Four Gigabit Ethernet RJ45 ports (LAN1/2/3/4) and two SFP28 25 G LAN ports (LAN5/6) are located on the rear I/O panel. There is also a dedicated IPMI LAN is above the USB4/5 ports on the rear I/O panel. Refer to the LED Indicator section for LAN LED information.



Note: LAN3 and LAN4 are unavailable on X12SDV-8CE-SP4F.

IPMI LAN Pin Definition			
Pin#	Definition	Pin#	Definition
9	VCC	19	YEL-
10	TX1+	20	YEL+
11	TX1-	21	ORG+/GRN-
12	TX2+	22	ORG-/GRN+
13	TX2-	23	SGND
14	TX3+	24	SGND
15	TX3-	25	SGND
16	TX4+	26	SGND
17	TX4-		
18	GND		

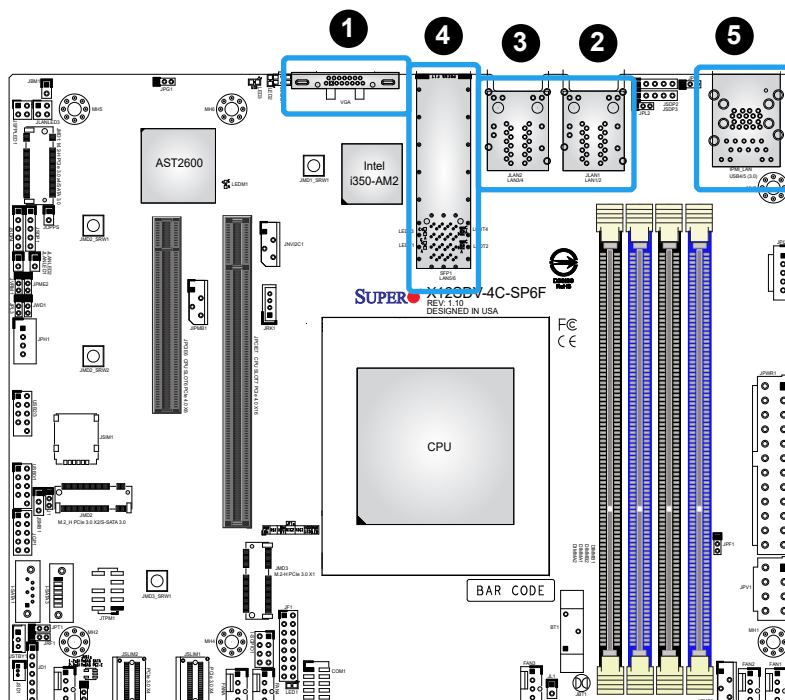

1. VGA Port
2. LAN1/2
3. LAN3/4
4. SFP LAN5/6
5. IPMI LAN

Universal Serial Bus (USB) Ports

There are two USB 3.0 ports (USB4/5) on the rear I/O panel and two USB 2.0 headers (USB0/1 and USB2/3) on the motherboard. The onboard headers can be used to provide front side USB access with a cable (not included).

Rear I/O USB4/5 Pin Definitions			
Pin#	Definition	Pin#	Definition
A1	VBUS	B1	VBUS
A2	D-	B2	D-
A3	D+	B3	D+
A4	GND	B4	GND
A5	Stda_SSRX-	B5	Stda_SSRX-
A6	Stda_SSRX+	B6	Stda_SSRX+
A7	GND	B7	GND
A8	Stda_SSTX-	B8	Stda_SSTX-
A9	Stda_SSTX+	B9	Stda_SSTX+

Front Panel USB0/1, USB2/3 Pin Definitions			
Pin#	Definition	Pin#	Definition
1	+5 V	2	+5 V
3	USB_PN2	4	USB_PN3
5	USB_PP2	6	USB_PP3
7	Ground	8	Ground
9	Key	10	Ground

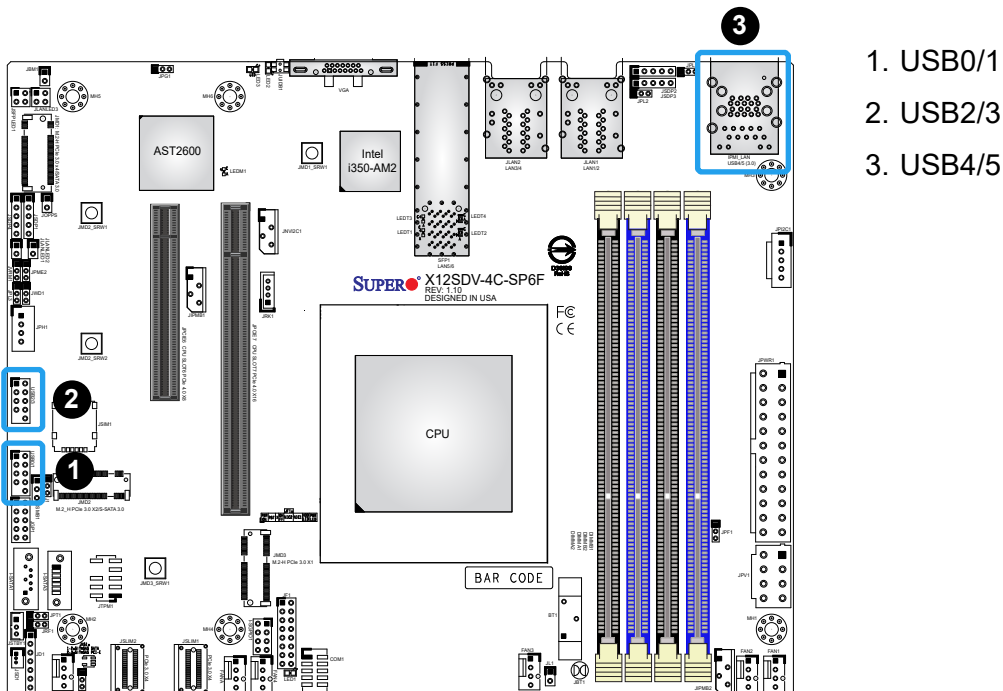

Unit Identifier Switch/UID LED Indicator

A Unit Identifier (UID) switch and an LED Indicator are located on the motherboard. The UID switch is located at JUIDB1, which is next to the VGA port on the rear I/O panel. The UID LED (LED2) is located next to the UID switch. When you press the UID switch, the UID LED will be turned on. Press the UID switch again to turn off the LED indicator. The UID Indicator provides easy identification of a system unit that may be in need of service.

 **Note:** UID can also be triggered via IPMI on the motherboard. For more information on IPMI, refer to the IPMI User's Guide posted on our website at <https://www.supermicro.com/support/manuals/>.

UID Switch Pin Definitions	
Pin#	Definition
1	Button In
2	Ground
3	Ground
4	Ground
5	Ground

UID LED Pin Definitions	
Color	Status
Blue: On	Unit Identified

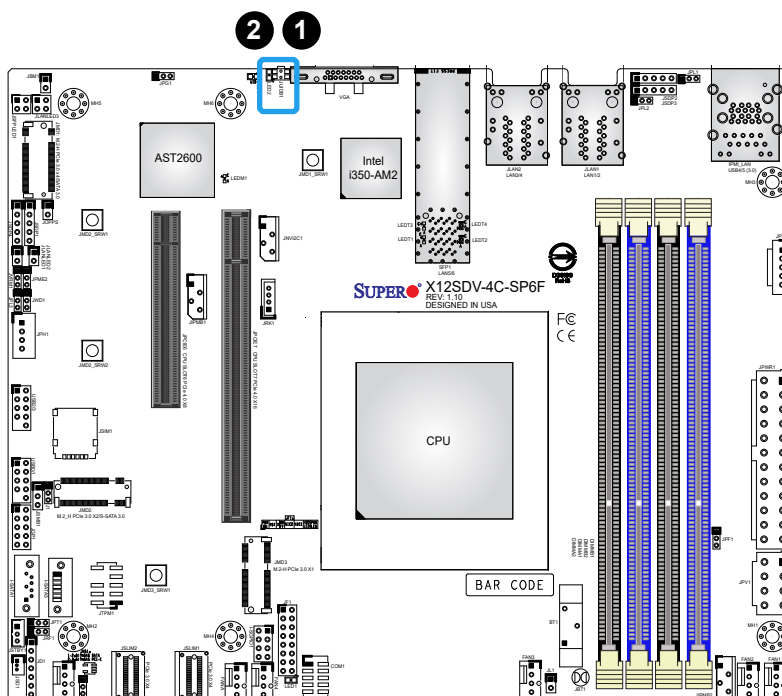

1. UID Switch
2. UID LED

2.5 Front Control Panel

JF1 contains header pins for various buttons and indicators that are normally located on a control panel at the front of the chassis. These connectors are designed specifically for use with Supermicro chassis. See the figure below for the descriptions of the front control panel buttons and LED indicators.

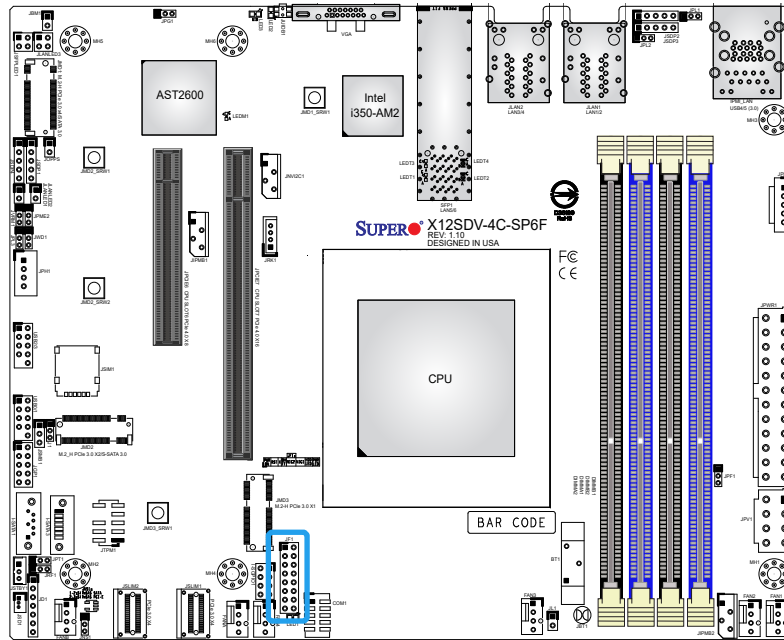

Figure 2-2. JF1 Header Pins

	1	2	
PWR } Power Button	○	○	Ground
Reset } Reset Button	○	○	Ground
3.3V	○	○	Power Fail LED
UID	○	○	OH/Fan Fail/PWR Fail LED
3.3V Stby	○	○	NIC2 Activity LED
3.3V Stby	○	○	NIC1 Activity LED
3.3V Stby	○	○	HDD LED
3.3V	○	○	PWR LED
	15	16	

Power Button

The Power Button connection is located on pins 1 and 2 of JF1. Momentarily contacting both pins will power on/off the system. This button can also be configured to function as a suspend button (with a setting in the BIOS – see Chapter 4). To turn off the power when the system is in suspend mode, press the button for 4 seconds or longer. Refer to the table below for pin definitions.

Power Button Pin Definitions (JF1)	
Pin#	Definition
1	Signal
2	Ground

Reset Button

The Reset Button connection is located on pins 3 and 4 of JF1. Attach it to a hardware reset switch on the computer case to reset the system. Refer to the table below for pin definitions.

Reset Button Pin Definitions (JF1)	
Pin#	Definition
3	Reset
4	Ground

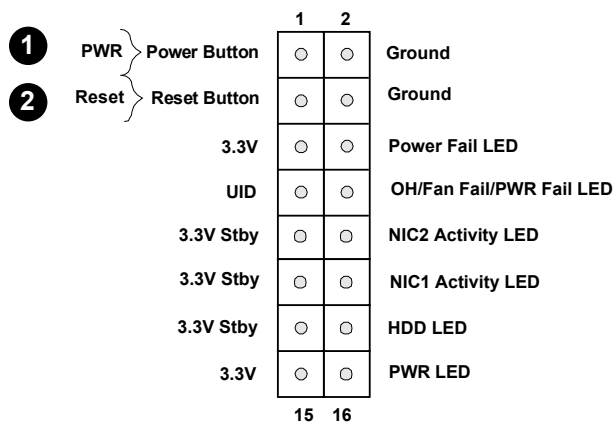

1. Power Button
2. Reset Button

Overheat (OH)/Fan Fail/PWR Fail LED

Connect an LED cable to pins 7 and 8 to use the Overheat (OH)/Fan Fail/PWR Fail LED connections. The LED on pin 8 provides warnings of overheat, fan failure, or power failure. Refer to the tables below for pin definitions.

OH/Fan Fail Indicator Status	
State	Definition
Off	Normal
On	Overheat
Flashing	Fan Fail/PWR Fail

OH/Fan Fail LED Pin Definitions (JF1)	
Pins	Definition
7	Blue UID LED
8	OH/Fan Fail/PWR Fail LED

NIC1/NIC2 (LAN1/LAN2)

The Network Interface Controller (NIC) LED connection for LAN port 1 is located on pins 11 and 12 of JF1, and LAN port 2 is on pins 9 and 10. Attach the NIC LED cables here to display network activity. Refer to the table below for pin definitions.

NIC1/NIC2 LED Pin Definitions (JF1)	
Pins	Definition
9	3.3 Stby
10	NIC2 Activity LED
11	3.3 Stby
12	NIC1 Activity LED

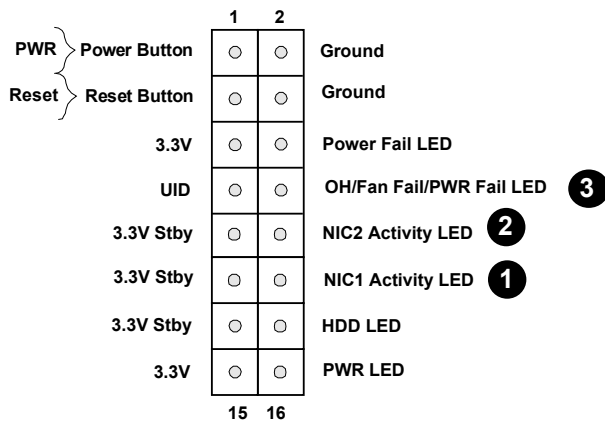

1. NIC1 Activity LED
2. NIC2 Activity LED
3. OH/Fan Fail/PWR Fail LED

HDD LED

The HDD LED connection is located on pins 13 and 14 of JF1. Attach a cable to pin 14 to show hard drive activity status. Refer to the table below for pin definitions.

HDD LED Pin Definitions (JF1)	
Pins	Definition
13	3.3 V Stby
14	HDD LED

Power LED

The Power LED connection is located on pins 15 and 16 of JF1. Refer to the table below for pin definitions.

Power LED Pin Definitions (JF1)	
Pins	Definition
15	3.3 V
16	PWR LED

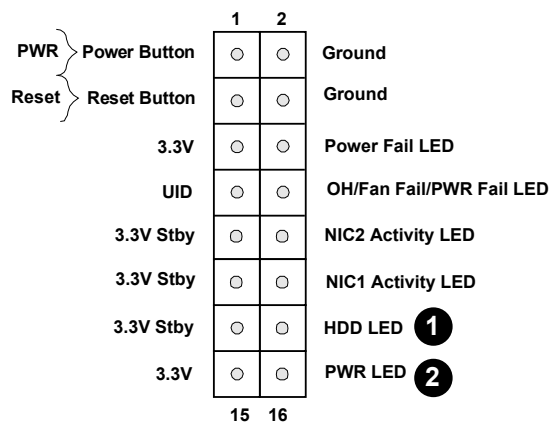

1. HDD LED
2. Power LED

Power Fail LED

Connect an LED cable to Power Fail connections on pins 5 and 6 of JF1 to provide warnings for a power failure. Refer to the table below for pin definitions.

PWR Fail LED Indicator Status	
Pins	Definition
5	3.3 V
6	PWR Fail LED

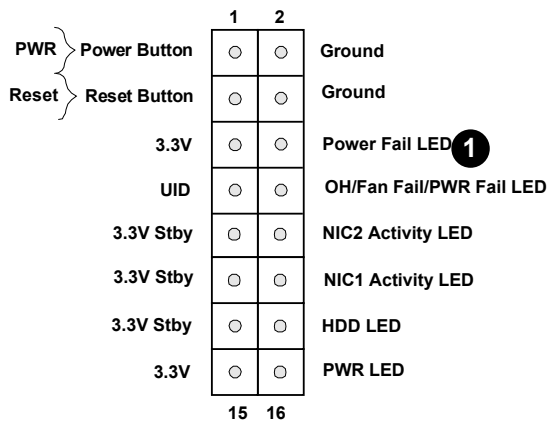

1. Power Fail LED

2.6 Connectors

Power Connections

ATX Power Supply Connector

The 24-pin power supply connector (JPWR1) meets the ATX SSI EPS 24-pin specification. The 8-pin (JPV1) connector is used to provide alternative power for a special enclosure when the 24-pin ATX power is not in use.

ATX Power 24-pin Connector Pin Definitions			
Pin#	Definition	Pin#	Definition
13	+3.3 V	1	+3.3 V
14	-12 V	2	+3.3 V
15	Ground	3	Ground
16	PS_ON	4	+5 V
17	Ground	5	Ground
18	Ground	6	+5 V
19	Ground	7	Ground
20	Res (NC)	8	PWR_OK
21	+5 V	9	5 VSB
22	+5 V	10	+12 V
23	+5 V	11	+12 V
24	Ground	12	+3.3 V

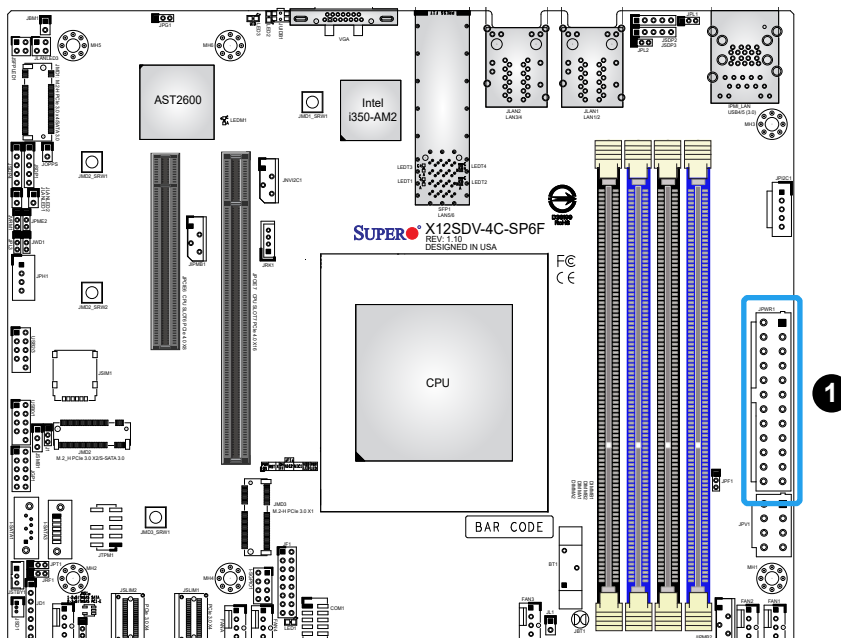

1. 24-pin ATX Power

8-Pin Power Connector

The 8-pin (JPV1) connector is used to provide alternative power for a special enclosure when the 24-pin ATX power is not in use. Refer to the table below for pin definitions.

8-pin Power Pin Definitions	
Pin#	Definition
1-4	Ground
5-8	P12V (12 V Power)

Required Connection

4-Pin HDD Power Connector

JPH1 is a 4-pin HDD power connector that provides power to onboard HDD devices.

4-pin HDD Power Pin Definitions	
Pin#	Definition
1	12 V
2-3	Ground
4	5 V

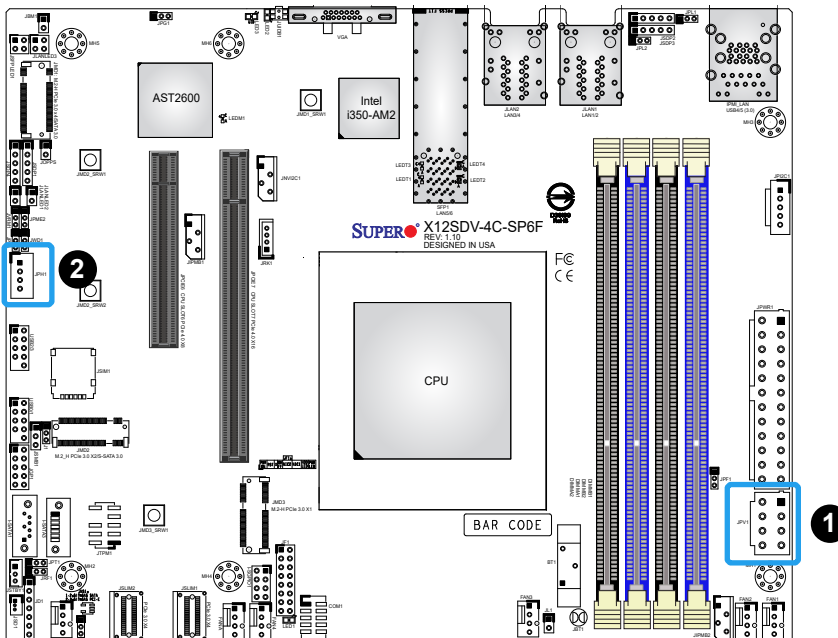

1. 8-pin 12 V DC Power
2. 4-pin HDD Power

Headers

Chassis Intrusion

A Chassis Intrusion header is located at JL1 on the motherboard. Attach the appropriate cable from the chassis to inform you of a chassis intrusion when the chassis is opened. Refer to the table below for pin definitions.

Chassis Intrusion Pin Definitions	
Pin#	Definition
1	Intrusion Input
2	Ground

COM Header

The motherboard has one COM header (COM1) that provides a serial connection .

COM Header (COM1) Pin Definitions			
Pin#	Definition	Pin#	Definition
1	DCD	2	DSR
3	RXD	4	RTS
5	TXD	6	CTS
7	DTR	8	RI
9	Ground	10	N/A

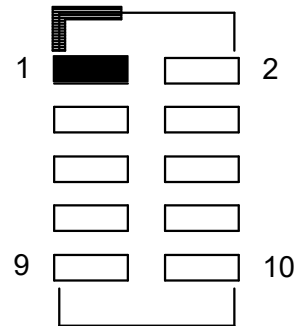

1. Chassis Intrusion
2. COM Header

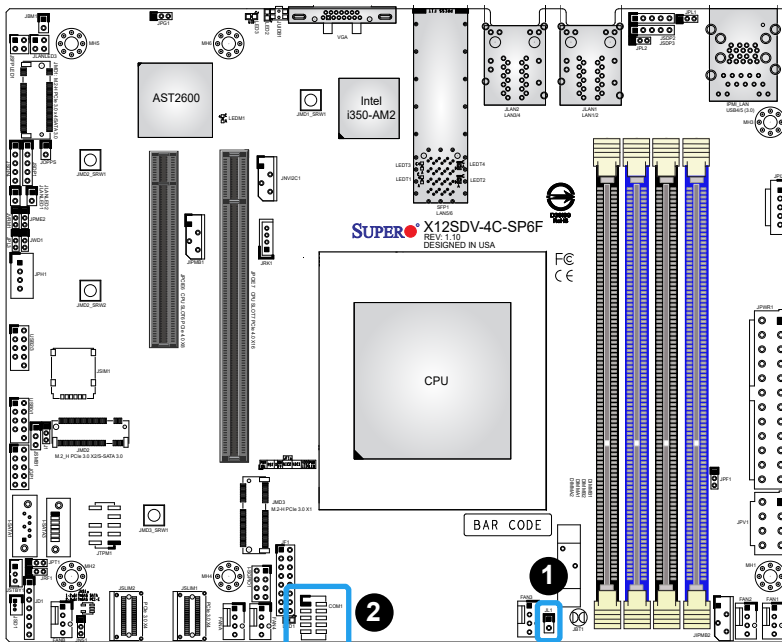

Disk-On-Module Power Connector

One power connector for SATA Disk-On-Module (DOM) devices is located at JSD1. Connect appropriate cables here to provide power support for your Serial Link DOM devices.

DOM Power Pin Definitions	
Pin#	Definition
1	5 V
2	Ground
3	Ground

General Purpose I/O Header

The General Purpose Input/Output (GPIO) header at JPG1 is a general purpose I/O expander on a pin header via the SMBus. Each pin can be configured to be an input pin or output pin in 2.54mm pitch. The GPIO is controlled via the PCA9554APW 8-bit GPIO expansion from PCH SMBus. The base address is 0xEFA0. The expander slave address is 0x70 for WRITE and 0x71 for READ. See the table below for pin definitions.

General Purpose I/O Header Pin Definitions			
Pin#	Definition	Pin#	Definition
1	+3.3 V Standby	2	GND
3	GP0	4	GP4
5	GP1	6	GP5
7	GP2	8	GP6
9	GP3	10	GP7

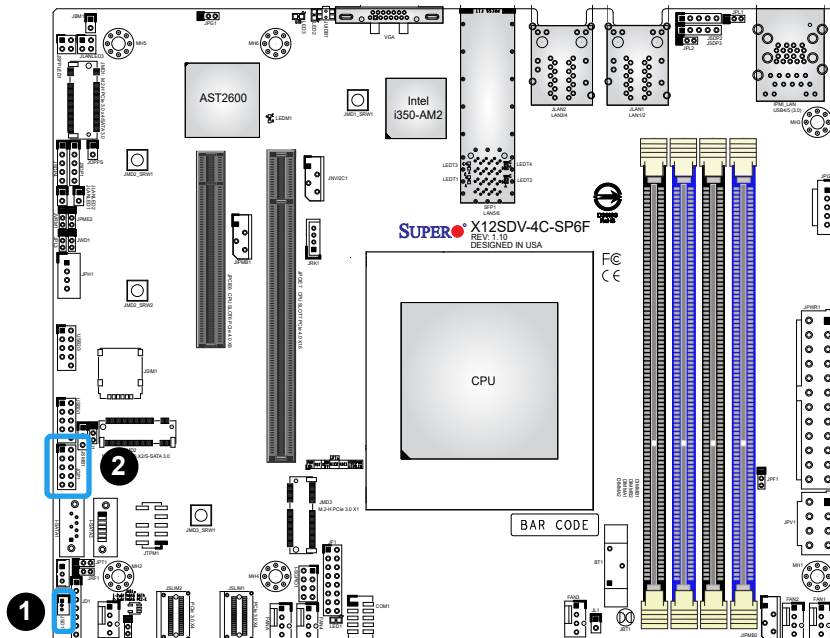

1. DOM Power Connector
2. GPIO Header

Fan Headers

There are six 4-pin fan headers (FAN1 – FAN4, FANA, FANB) on the motherboard. All these 4-pin fan headers are backwards compatible with traditional 3-pin fans. However, fan speed control is available for 4-pin fans only by Thermal Management via the Hardware Monitoring in the BIOS. Refer to the table below for pin definitions.

Fan Header Pin Definitions	
Pin#	Definition
1	Ground (Black)
2	+12 V (Red)
3	Tachometer
4	PWM_Control

4-pin External BMC I²C Headers

System Management Bus headers for IPMI 2.0 are located at JIPMB1 and JIPMB2. Connect a cable to the header to use the IPMB I²C connection on your system. Refer to the table below for pin definitions.

External I ² C Header Pin Definitions	
Pin#	Definition
1	Data
2	Ground
3	Clock
4	No Connection

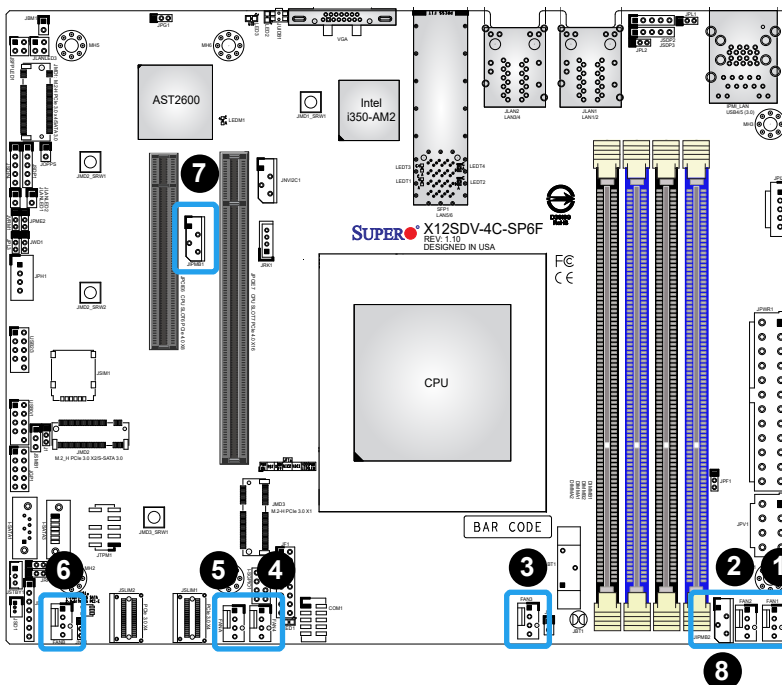

1. FAN1 Header
2. FAN2 Header
3. FAN3 Header
4. FAN4 Header
5. FANA Header
6. FANB Header
7. BMC I²C Header
8. BMC I²C Header

I-SATA 3.0 Ports

This motherboard has two I-SATA 3.0 ports (I-SATA1, I-SATA3). I-SATA1 can be used with Supermicro SuperDOMs that are yellow SATA DOM connectors with power pins built in, and do not require external power cables. Supermicro SuperDOMs are backwards compatible with regular SATA HDDs or SATA DOMs that need external power cables.

Intel RAID Key Header

The JRK1 header allows you to enable RAID functions for NVMe connections. Refer to the table below for pin definitions.

Intel RAID Key Header Pin Definitions	
Pin#	Defintion
1	GND
2	PU 3.3 V Stdby
3	GND
4	PCH RAID KEY

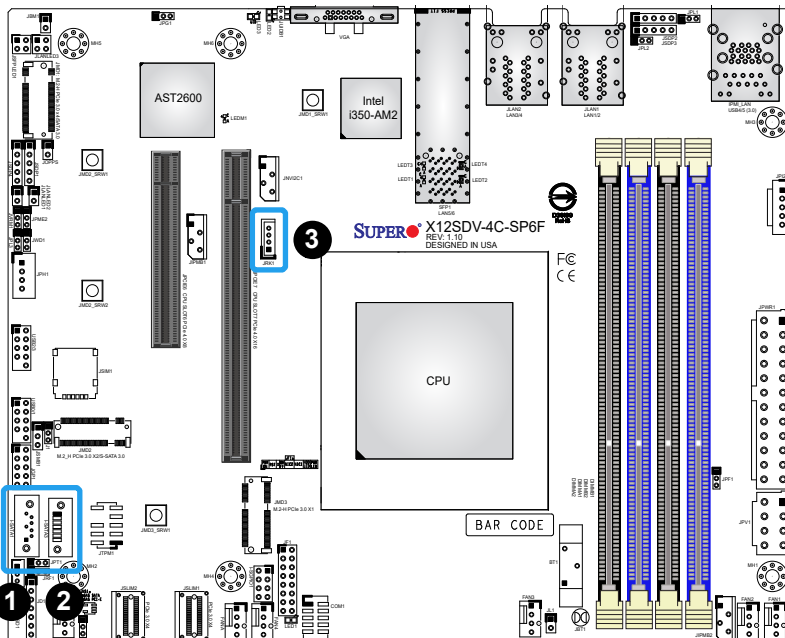

1. I-SATA 3.0 Port
2. I-SATA 3.0 Port
3. Intel RAID Key Header

JOPPS

JOPPS is reserved for One Pulse Per Second.

JSDP1 – JSDP4

JSDP1, JSDP2, JSDP3, and JSDP4 are reserved for time synchronization.

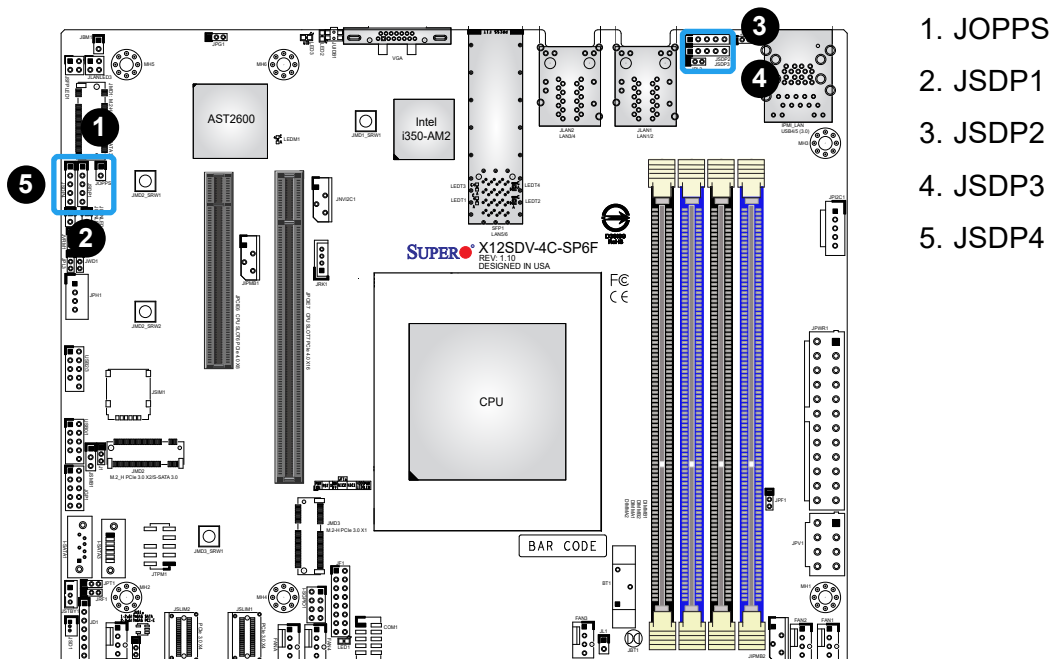

LAN5/6 Activity LED

JSFPLED1 is the activity LED header for LAN5/6.

LAN Activity LED

JLANLED1 is the activity LED header for LAN1, JLANLED2 is the activity LED header for LAN2, and JLANLED3 is the activity LED header for LAN3/4.

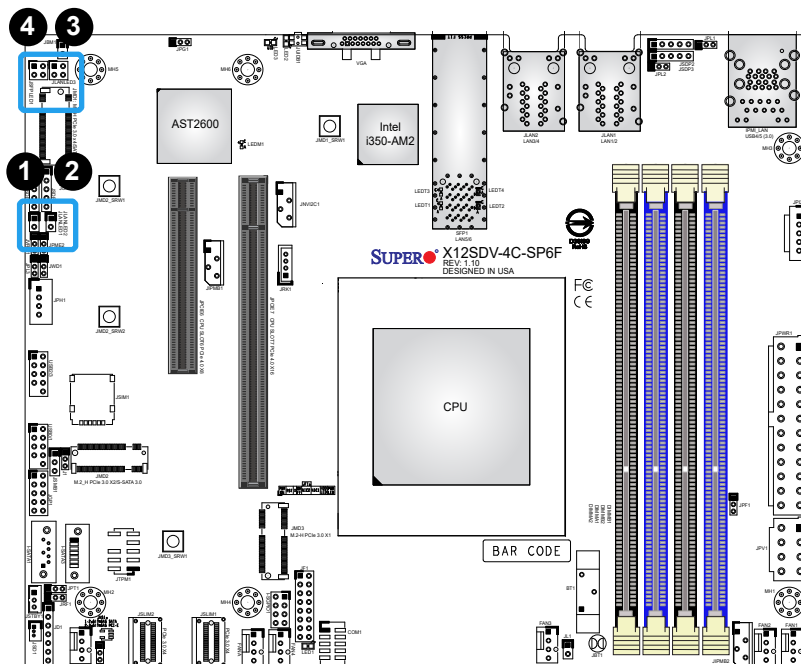

- 1. LAN1 Activity LED
- 2. LAN2 Activity LED
- 3. LAN3/4 Activity LED
- 4. LAN5/6 Activity LED

M.2 Slot

This motherboard has three M.2 slots (JMD1, JMD2, JMD3). M.2 was formerly known as Next Generation Form Factor (NGFF) and serves to replace mini PCIe. M.2 allows for a variety of card sizes, increased functionality, and spatial efficiency. JMD1 supports an M-Key PCIe 3.0 x4 or SATA 3.0 device in the 2280 form factor. JMD2 supports a B-Key PCIe 3.0 x2, SATA 3.0, or USB 3.0 device in the 2280/3042/3052 form factors. JMD3 supports an E-Key PCIe 3.0 x1 or USB 2.0 device in the 2230 form factor.



Note: For B-Key 3052 support, use an MCP-410-00021-0N bracket.

Nano SIM Slot

The JSIM1 slot supports a Nano SIM card.

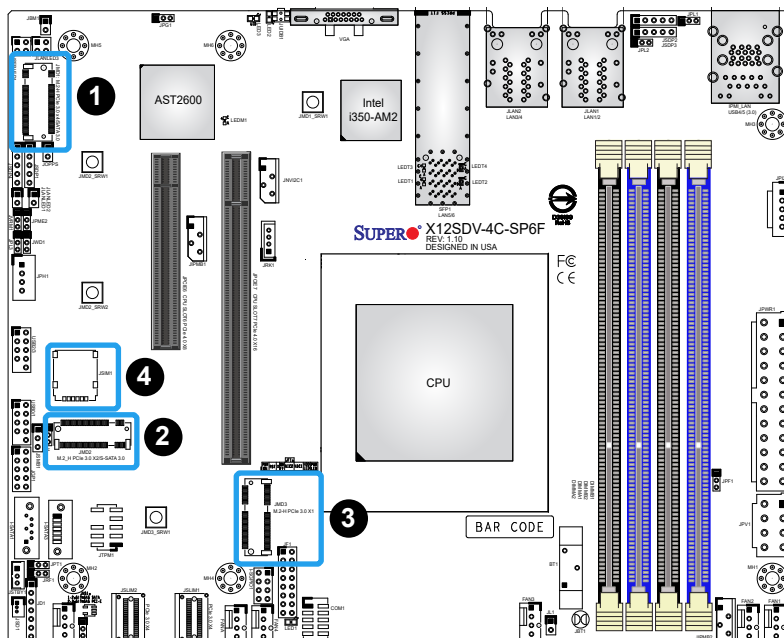

1. M.2 Slot (M-Key 2280)
2. M.2 Slot
(B-Key 2280/3042/3052)
3. M.2 Slot (E-key 2230)
4. Nano SIM Slot

Power SMB (I²C) Header

The Power System Management Bus (I²C) header at JPI2C1 monitors the power supply, fan and system temperatures. Refer to the table below for pin definitions.

Power SMB Header Pin Definitions	
Pin#	Definition
1	Clock
2	Data
3	Power Fail
4	Ground
5	NC

NVMe I²C Header

The connector at JNVI2C1 is a management header for the Supermicro AOC NVMe PCIe peripheral cards. Connect the I²C cable to these connectors.

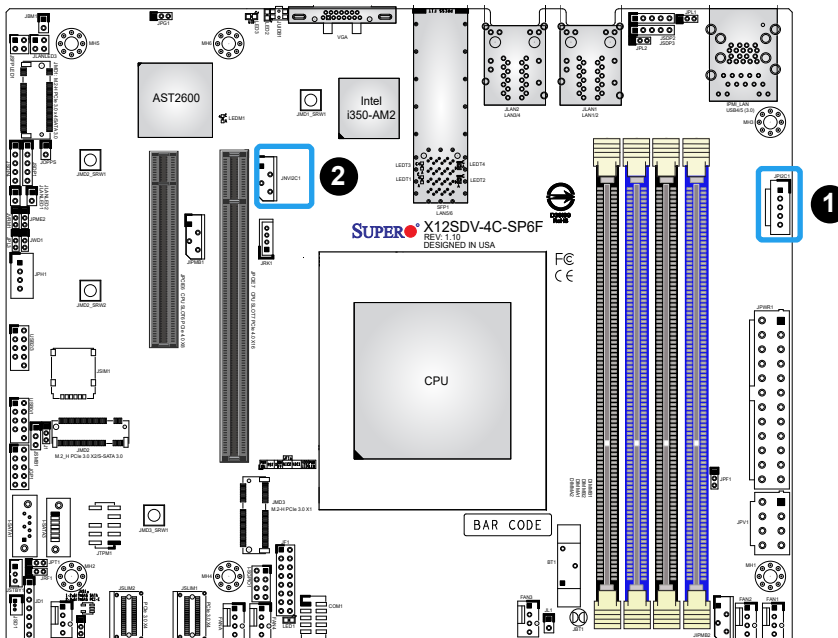

1. Power SMB I²C Header
2. NVMe I²C Header

SGPIO Header

There is one Serial Link General Purpose Input/Output (I-SGPIO1) header located on the motherboard. Refer to the table below for pin definitions.

SGPIO Header Pin Definitions			
Pin#	Definition	Pin#	Definition
1	NC	2	NC
3	Ground	4	SSATA Data
5	SSATA Load	6	Ground
7	SSATA Clock	8	NC

SlimSAS Connectors

The SlimSAS connectors at JSLIM1 and JSLIM2 each support either one PCIe 3.0 x4 or four SATA devices.

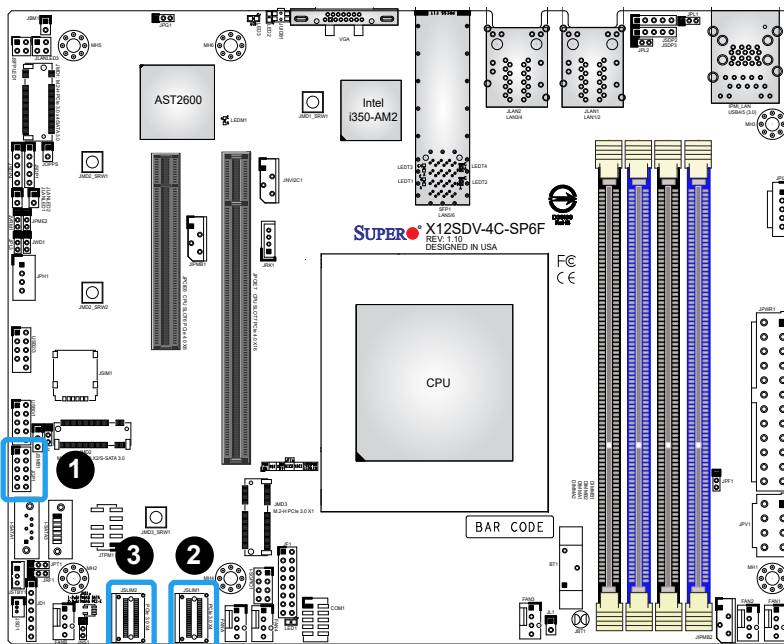

1. General Purpose I/O Header
2. SlimSAS Connector
3. SlimSAS Connector

Speaker/Power LED

Pins 1-3 of JD1 are used for power LED indication, and pins 4-7 are for the speaker. Note that the speaker connector pins are used with an external speaker. Refer to the tables below for pin definitions.

PWR LED Connector Pin Definitions	
Pin#	Signal
1	FP_PWR_LED_P
2	FP_PWR_LED_N
3	FP_PWR_LED_N

Speaker Connector Pin Definitions	
Pin#	Signal
4	P5V
5	NC
6	NC
7	R_SPKRIN

Standby Power

The Standby Power header is located at JSTBY1 on the motherboard. You must have a card with a Standby Power connector and a cable to use this feature. Refer to the table below for pin definitions.

Standby Power Pin Definitions	
Pin#	Definition
1	+5 V Standby
2	Ground
3	No Connection

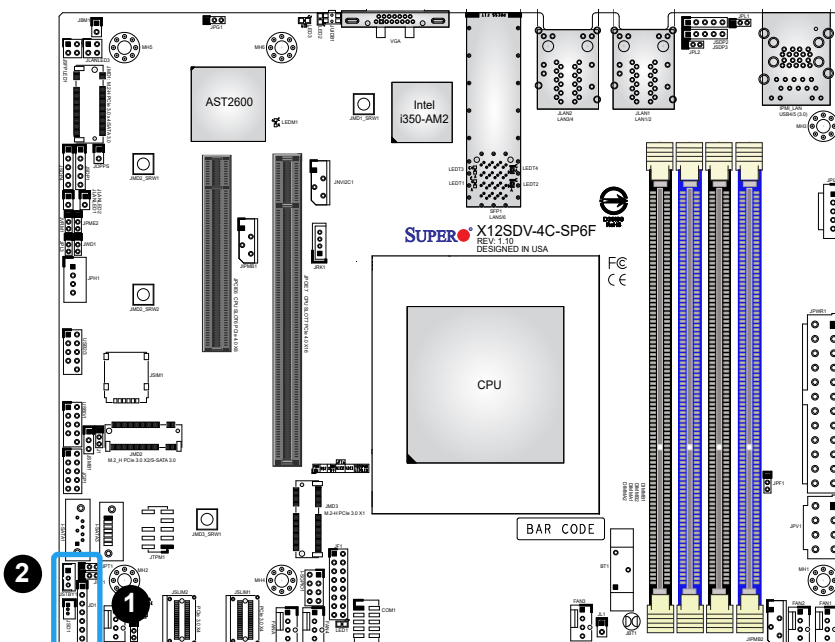

1. Speaker/Power LED
2. Standby Power

System Management Bus Header

A System Management Bus (SMBus) header for additional slave devices or sensors is located at JSMB1. Refer to the table below for pin definitions.

SMBus Header Pin Definitions	
Pin#	Definition
1	Data
2	Ground
3	Clock

Trusted Platform Module (TPM)/Port 80 Header

A Trusted Platform Module (TPM)/Port 80 header is located at JTPM1 to provide TPM 2.0 support and Port 80 connection. Use this header to enhance system performance and data security. Refer to the table below for pin definitions. Go to the following link for more information on the TPM: <http://www.supermicro.com/manuals/other/TPM.pdf>.

Trusted Platform Module Header Pin Definitions			
Pin#	Definition	Pin#	Definition
1	+3.3 V	2	SPI_CS#
3	RESET#	4	SPI_MISO
5	SPI_CLK	6	GND
7	SPI_MOSI	8	
9	+3.3 V Stby	10	SPI_IRQ#

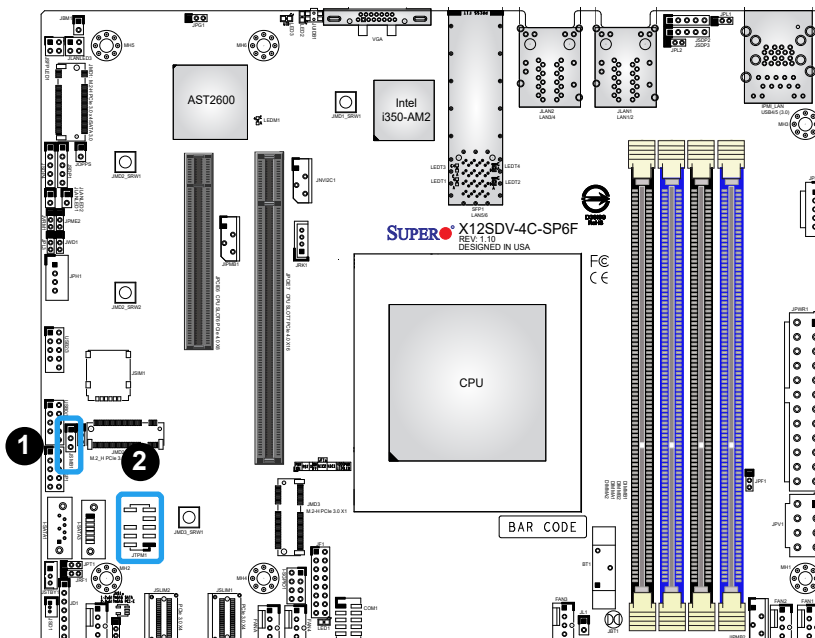

1. SMBus Header
2. TPM/Port 80 Header

2.7 Jumper Settings

How Jumpers Work

To modify the operation of the motherboard, jumpers can be used to choose between optional settings. Jumpers create shorts between two pins to change the function of the connector. Pin 1 is identified with a square solder pad on the printed circuit board. See the diagram below for an example of jumping pins 1 and 2. Refer to the motherboard layout page for jumper locations.

 **Note:** On two-pin jumpers, "Closed" means the jumper is on and "Open" means the jumper is off the pins.

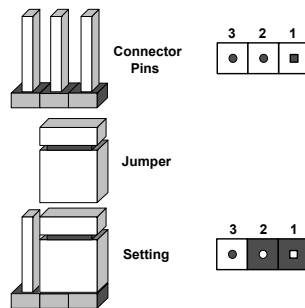

CMOS Clear

JBT1 is used to clear CMOS, which will also clear any passwords. Instead of pins, this jumper consists of contact pads to prevent accidentally clearing the contents of CMOS.

To Clear CMOS

1. First power down the system and unplug the power cord(s).
2. Remove the cover of the chassis to access the motherboard.
3. Remove the onboard battery from the motherboard.
4. Short the CMOS pads with a metal object such as a small screwdriver for at least four seconds.
5. Remove the screwdriver (or shorting device).
6. Replace the cover, reconnect the power cord(s), and power on the system.

 **Note:** Clearing CMOS will also clear all passwords.



JBT1 contact pads

Watchdog Timer

Watchdog (JWD1) is a system monitor that can reboot the system when a software application hangs. Close pins 1-2 to reset the system if an application hangs. Close pins 2-3 to generate a non-maskable interrupt (NMI) signal for the application that hangs. Refer to the table below for jumper settings. The Watchdog must also be enabled in the BIOS.

Watchdog Jumper Settings	
Jumper Setting	Definition
Pins 1-2	Reset (Default)
Pins 2-3	NMI
Open	Disabled

Onboard TPM 2.0 Enable/Disable

Use JPT1 to enable or disable support for the onboard TPM 2.0 module. The default setting is Enabled.

TPM 2.0 Enable/Disable Jumper Settings	
Jumper Setting	Definition
Pins 1-2	Enabled (Default)
Pins 2-3	Disabled

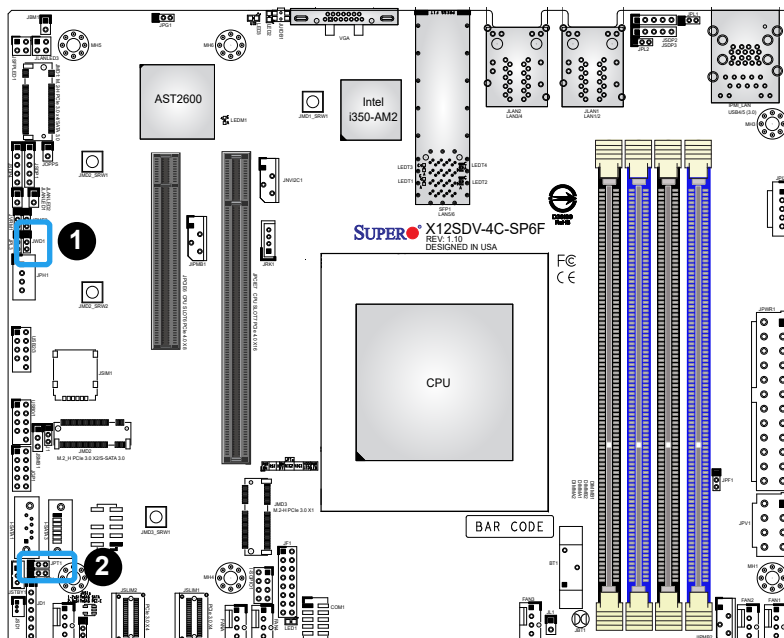

1. Watchdog Timer
2. Onboard TPM 2.0

SlimSAS Interface Selection

Use the JNS1 jumper to set the SlimSAS port to either function as four SATA ports or a single PCIe x4 NVMe interface. The default settings is PCIe x4.

SlimSAS Interface Selection Jumper Settings	
Jumper Setting	Definition
Pins 1-2	4x SATA
Pins 2-3	PCIe x4 (Default)

VGA Enable/Disable

JPG1 allows you to enable or disable the VGA port using the onboard graphics controller. The default setting is Enabled.

VGA Enable/Disable Jumper Settings	
Jumper Setting	Definition
Pins 1-2	Enabled (Default)
Pins 2-3	Disabled

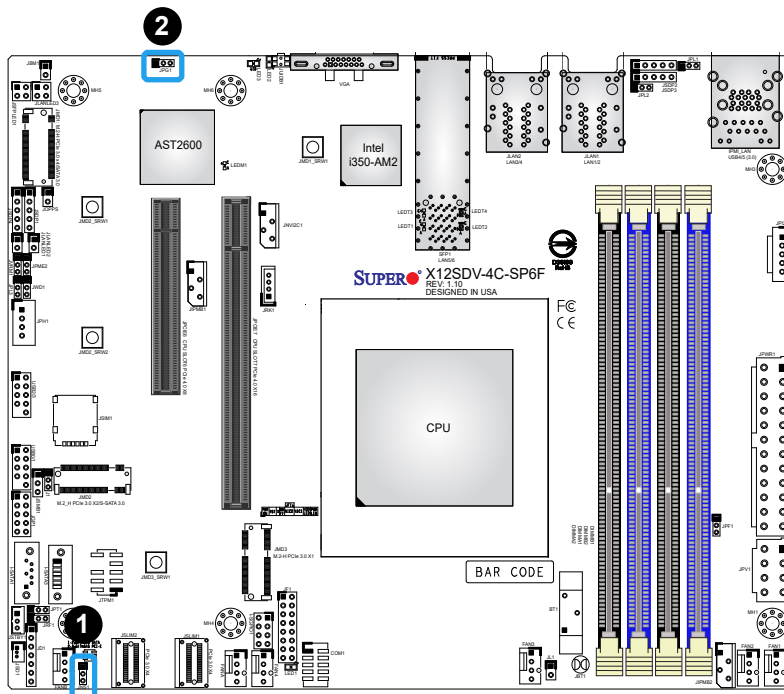

1. SlimSAS Interface Selection
2. VGA Enable/Disable

LAN1, LAN2, LAN3/4 Enable/Disable

Use JPL1 to enable or disable LAN1, JPL2 to enable or disable LAN2, and JPL3 to enable or disable LAN3/4. The default setting is Enabled.

LAN Port Enable/Disable Jumper Settings	
Jumper Setting	Definition
Pins 1-2	Enabled (Default)
Pins 2-3	Disabled

Manufacturing Mode Select

Close pins 2-3 of jumper JPME2 to bypass SPI flash security and force the system to operate in the manufacturing mode, which will allow you to flash the system firmware from a host server for system setting modifications. Refer to the table below for jumper settings.

Manufacturing Mode Jumper Settings	
Jumper Setting	Definition
Pins 1-2	Normal (Default)
Pins 2-3	Manufacturing Mode

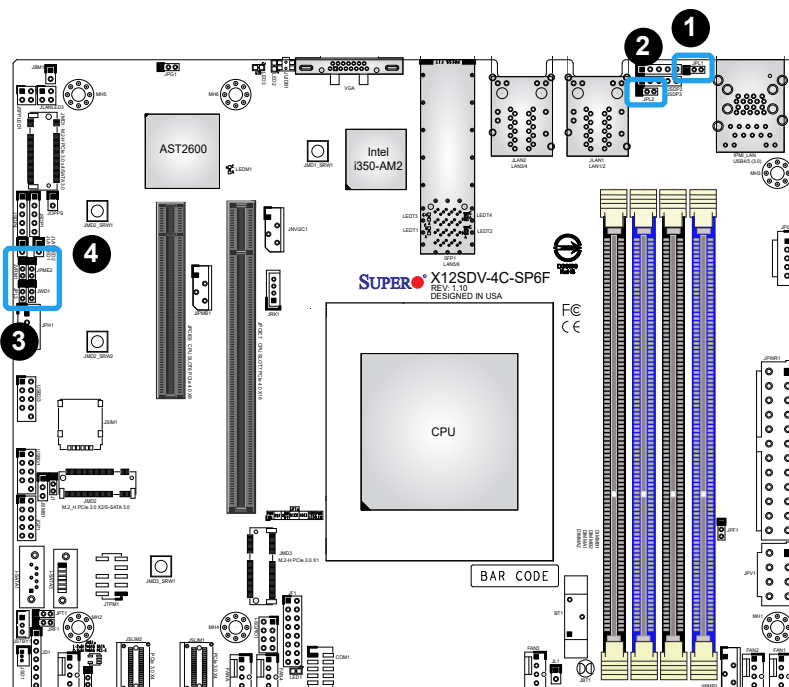

1. LAN1 Enable/Disable
2. LAN2 Enable/Disable
3. LAN3/4 Enable/Disable
4. Manufacturing Mode

IPMI Shared LAN Enable/Disable

Set the JBM1 jumper to enable or disable IPMI shared access on LAN1 (Intel I210-AT). The default settings is Enabled.

IPMI Share LAN Enable/Disable Jumper Settings	
Jumper Setting	Definition
Pins 1-2 (Open)	Enabled (Default)
Pins 1-2 (Short)	Disabled

SIM Card Detection

J1 is the SIM card detection jumper. The default setting is High Active.

SIM Card Detection Jumper Settings	
Jumper Setting	Definition
Pins 1-2	High Active (Default)
Pins 2-3	Low Active

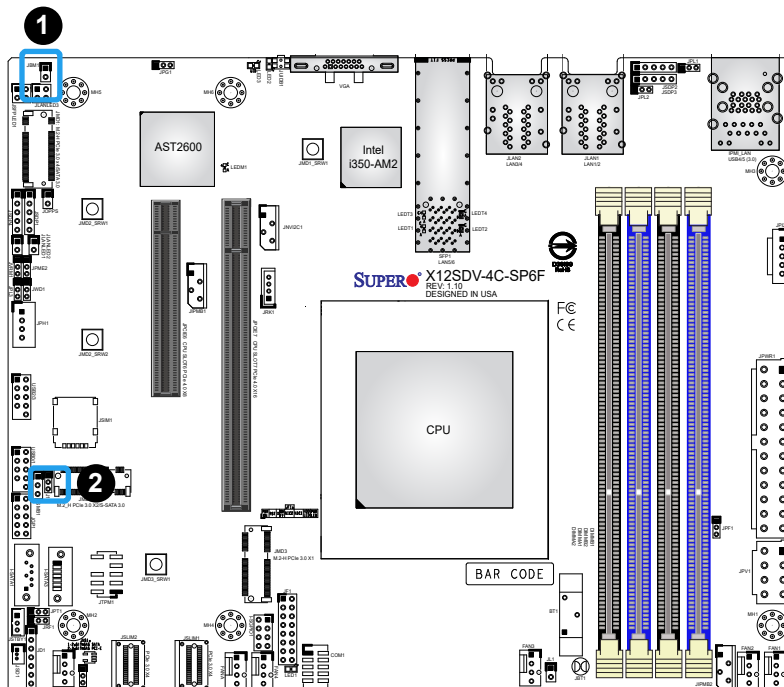

1. IPMI Shared LAN Enable/Disable
2. SIM Card Detection

Force Power On

JPF1 is the Force Power On jumper. The default settings is ATX Mode.

Force Power On Jumper Settings	
Jumper Setting	Definition
Pins 1-2	ATX (Default)
Pins 2-3	Force PS-ON Mode

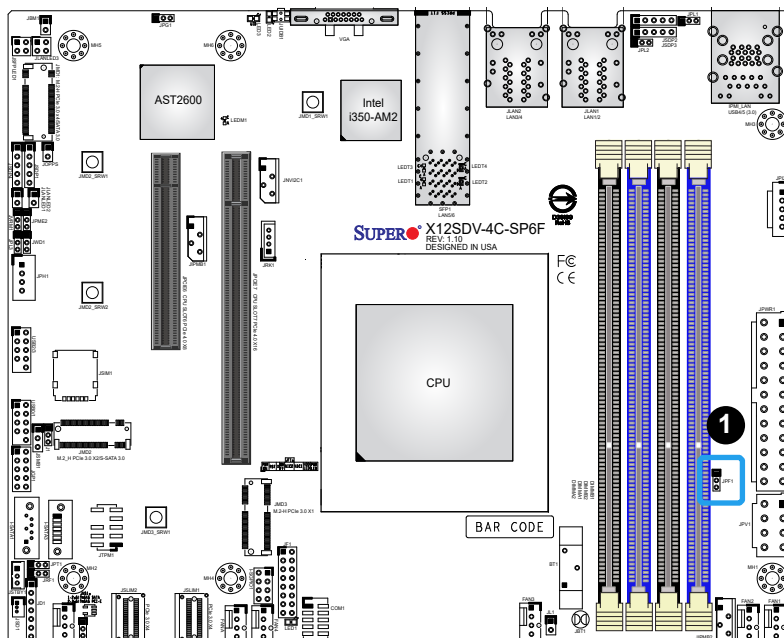

1. Force Power On

2.8 LED Indicators

Power LED

LED1 is the Power LED. When this LED is lit, power is present on the motherboard. In suspend mode, this LED will blink on and off. Turn off the system and unplug the power cord before removing or installing components.

Power LED Indicator	
LED Color	Definition
Off	System Off (power cable not connected)
Green	System On

Overheat/PWR Fail/Fan Fail LED

LED3 is the Overheat, Power Fail, and Fan Fail LED.

Overheat/Power Fail/Fan Fail LED	
LED Color	Definition
Solid Red	System Overheat
Blinking Red	PWR Fail or Fan Fail

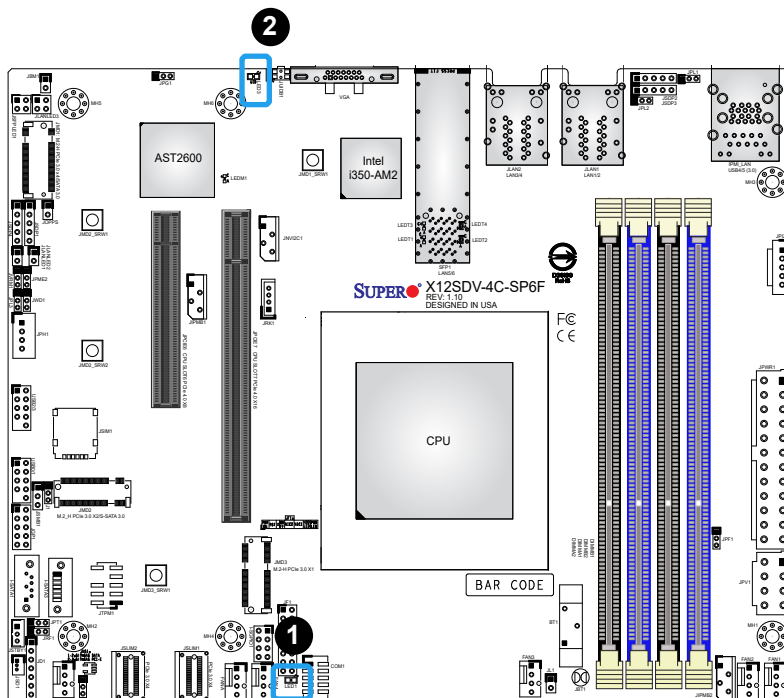

1. Power LED
2. Overheat/PWR Fail/Fan Fail LED

BMC Heartbeat LED

LED1 is the BMC heartbeat LED. When the LED is blinking green, BMC is functioning normally. Refer to the table below for the LED status.

BMC Heartbeat LED Indicator	
LED Color	Definition
Green: Blinking	BMC Normal

LAN LEDs

Four LAN ports (LAN1 – LAN4) are located on the rear I/O panel of the motherboard. Each Ethernet LAN port has two LEDs. The green LED indicates activity, while the other Link LED may be green, amber, or off to indicate the speed of the connection. Refer to the tables below for more information.

LAN Activity LED (Left)		
LED State		
Color	Status	Definition
Yellow	Flashing	Active

LAN Link LED (Right)	
LED State	
LED Color	Definition
Off	No Connection
Amber	1 Gbps
Green	100 Mbps

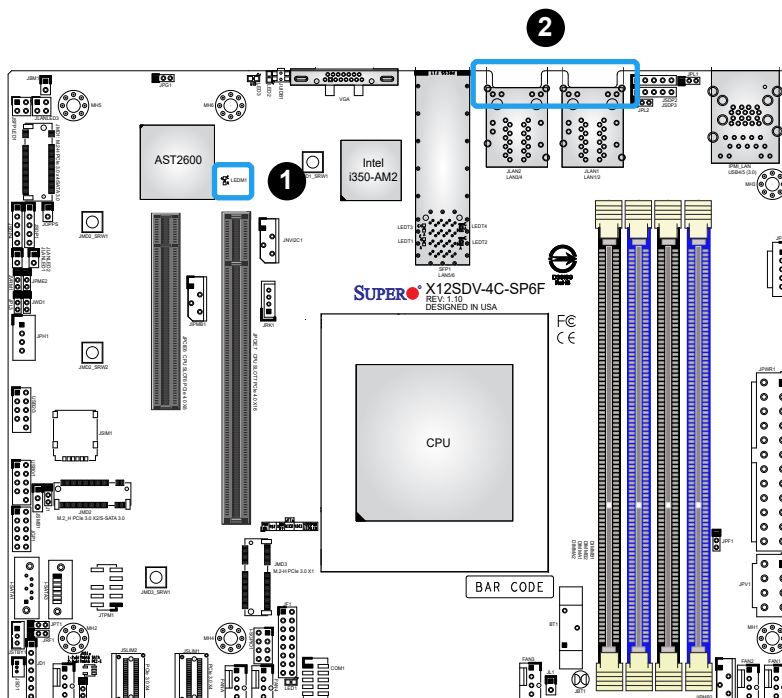

1. BMC Heartbeat LED
2. LAN Port LED

SFP LAN LEDs

SFP28 25 G/10 G LAN LED indicators are located on the rear I/O panel. Refer to the tables below for more information.

LAN Activity LED (Left)		
LED State		
Color	Status	Definition
Yellow	Flashing	Active

LAN Link LED (Right)	
LED State	
LED Color	Definition
Green	25 Gbps
Yellow	10 Gbps

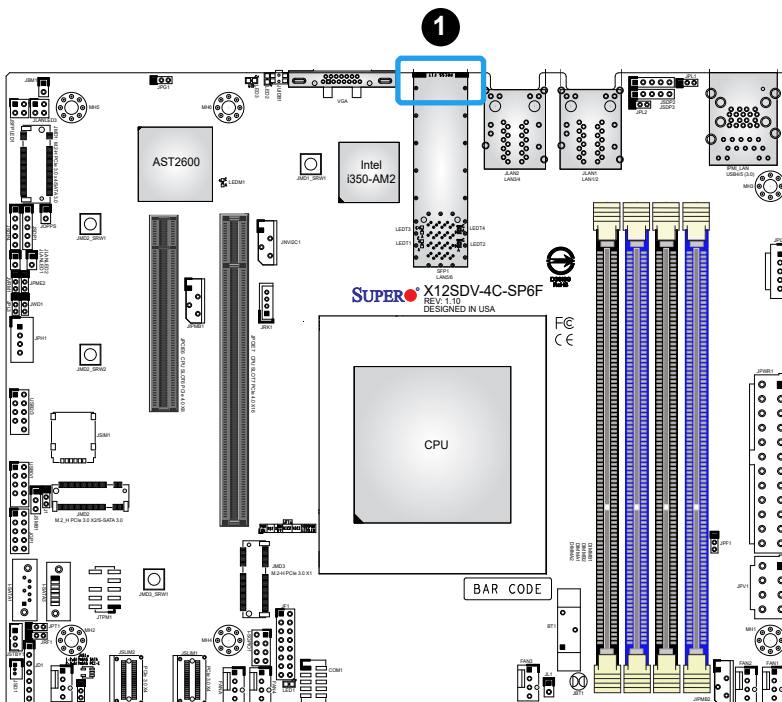

1. SFP LAN Port LEDs

Chapter 3

Troubleshooting

3.1 Troubleshooting Procedures

Use the following procedures to troubleshoot your system. If you have followed all of the procedures below and still need assistance, refer to the 'Technical Support Procedures' and/or 'Returning Merchandise for Service' section(s) in this chapter. Always disconnect the AC power cord before adding, changing or installing any non hot-swap hardware components.

Before Power On

1. Make sure that there are no short circuits between the motherboard and chassis.
2. Disconnect all ribbon/wire cables from the motherboard, including those for the keyboard and mouse.
3. Remove all add-on cards.
4. Install the CPU (making sure it is fully seated) and connect the front panel connectors to the motherboard.

No Power

1. Make sure that there are no short circuits between the motherboard and the chassis.
2. Make sure that the ATX power connectors are properly connected.
3. Check that the 115 V/230 V switch, if available, on the power supply is properly set.
4. Turn the power switch on and off to test the system, if applicable.
5. The battery on your motherboard may be old. Check to verify that it still supplies approximately 3 VDC. If it does not, replace it with a new one.

No Video

1. If the power is on, but you have no video, remove all add-on cards and cables.
2. Use the speaker to determine if any beep codes are present. Refer to Appendix A for details on beep codes.
3. Remove all memory modules and turn on the system. If the alarm is on, check the specs of memory modules, reset the memory or try a different one.

System Boot Failure

If the system does not display Power-On-Self-Test (POST) or does not respond after the power is turned on, check the following:

1. Check for any error beep from the motherboard speaker.
 - If there is no error beep, try to turn on the system without DIMM modules installed. If there is still no error beep, replace the motherboard.
 - If there are error beeps, clear the CMOS settings by unplugging the power cord and contacting both pads on the CMOS clear jumper (JBT1). Refer to Section 2.7 in Chapter 2.
2. Remove all components from the motherboard, especially the DIMM modules. Make sure that system power is on and that memory error beeps are activated.
3. Turn on the system with only one DIMM module installed. If the system boots, check for bad DIMM modules or slots by following the Memory Errors Troubleshooting procedure in this chapter.

Memory Errors

When a no-memory beep code is issued by the system, check the following:

1. Make sure that the memory modules are compatible with the system and are properly installed. See Chapter 2 for installation instructions. For memory compatibility, refer to the "Tested Memory List" link on the motherboard's product page to see a list of supported memory.
2. Check if different speeds of DIMMs have been installed. It is strongly recommended that you use the same RAM type and speed for all DIMMs in the system.
3. Make sure that you are using the correct type of ECC or Non-ECC DDR4 modules recommended by the manufacturer.
4. Check for bad DIMM modules or slots by swapping a single module among all memory slots and check the results.

Losing the System's Setup Configuration

1. Make sure that you are using a high-quality power supply. A poor-quality power supply may cause the system to lose the CMOS setup information. Refer to Chapter 2 for details on recommended power supplies.
2. The battery on your motherboard may be old. Check to verify that it still supplies approximately 3 VDC. If it does not, replace it with a new one.
3. If the above steps do not fix the setup configuration problem, contact your vendor for repairs.

When the System Becomes Unstable

A. If the system becomes unstable during or after OS installation, check the following:

1. CPU/BIOS support: Make sure that your CPU is supported and that you have the latest BIOS installed in your system.
2. Memory support: Make sure that the memory modules are supported by testing the modules using memtest86 or a similar utility.



Note: Click on the "Tested Memory List" link on the motherboard's product page to see a list of supported memory.

3. HDD support: Make sure that all hard disk drives (HDDs) work properly. Replace the bad HDDs with good ones.
4. System cooling: Check the system cooling to make sure that all heatsink fans and CPU/system fans, etc., work properly. Check the hardware monitoring settings in the BIOS to make sure that the CPU and system temperatures are within the normal range. Also check the front panel Overheat LED and make sure that it is not on.
5. Adequate power supply: Make sure that the power supply provides adequate power to the system. Make sure that all power connectors are connected. Refer to our website for more information on the minimum power requirements.
6. Proper software support: Make sure that the correct drivers are used.

B. If the system becomes unstable before or during OS installation, check the following:

1. Source of installation: Make sure that the devices used for installation are working properly, including boot devices such as USB flash or media drives.
2. Cable connection: Check to make sure that all cables are connected and working properly.

3. Use the minimum configuration for troubleshooting: Remove all unnecessary components (starting with add-on cards first), and use the minimum configuration (but with the CPU and a memory module installed) to identify the trouble areas. Refer to the steps listed in Section A above for proper troubleshooting procedures.
4. Identify bad components by isolating them: If necessary, remove a component in question from the chassis, and test it in isolation to make sure that it works properly. Replace a bad component with a good one.
5. Check and change one component at a time instead of changing several items at the same time. This will help isolate and identify the problem.
6. To find out if a component is good, swap this component with a new one to see if the system will work properly. If so, then the old component is bad. You can also install the component in question in another system. If the new system works, the component is good and the old system has problems.

3.2 Technical Support Procedures

Before contacting Technical Support, take the following steps. Also, note that as a motherboard manufacturer, Supermicro also sells motherboards through its channels, so it is best to first check with your distributor or reseller for troubleshooting services. They should know of any possible problems with the specific system configuration that was sold to you.

1. Go through the Troubleshooting Procedures and Frequently Asked Questions (FAQ) sections in this chapter or see the FAQs on our website (<http://www.supermicro.com/FAQ/index.php>) before contacting Technical Support.
2. BIOS upgrades can be downloaded from our website (http://www.supermicro.com/ResourceApps/BIOS_IPMI_Intel.html).
3. If you still cannot resolve the problem, include the following information when contacting Supermicro for technical support:
 - Motherboard model and PCB revision number
 - BIOS release date/version (This can be seen on the initial display when your system first boots up.)
 - System configuration
4. An example of a Technical Support form is on our website at <http://www.supermicro.com/RmaForm/>.
5. Distributors: For immediate assistance, have your account number ready when placing a call to our Technical Support department. We can be reached by email at support@supermicro.com.

3.3 Frequently Asked Questions

Question: What type of memory does my motherboard support?

Answer: The motherboard supports up to 256 GB of ECC and Non-ECC RDIMM/UDIMM DDR4 DDR4 memory with speeds of up to 2933 MT/s in four memory slots. To enhance memory performance, do not mix memory modules of different speeds and sizes. Follow all memory installation instructions given on section 2-3 in Chapter 2.

Question: How do I update my BIOS?

Answer: It is recommended that you do not upgrade your BIOS if you are not experiencing any problems with your system. Updated BIOS files are located on our website at http://www.supermicro.com/ResourceApps/BIOS_IPMI_Intel.html. Check our BIOS warning message and the information on how to update your BIOS on our website. Select your motherboard model and download the BIOS file to your computer. Also, check the current BIOS revision to make sure that it is newer than your BIOS before downloading. Unzip the BIOS file onto a bootable USB device. Run the batch file using the format FLASH.BAT filename.rom from your bootable USB device to flash the BIOS. Then, your system will automatically reboot.

Warning: Do not shut down or reset the system while updating the BIOS to prevent possible system boot failure!



Note: The SPI BIOS chip used on this motherboard cannot be removed. Send your motherboard back to our RMA Department at Supermicro for repair. For BIOS Recovery instructions, refer to the AMI BIOS Recovery Instructions posted at <http://www.supermicro.com/support/manuals/>.

3.4 Battery Removal and Installation

Battery Removal

To remove the onboard battery, follow the steps below:

1. Power off your system and unplug your power cable.
2. Locate the onboard battery as shown below.
3. Using a tool such as a pen or a small screwdriver, push the battery lock outwards to unlock it. Once unlocked, the battery will pop out from the holder.
4. Remove the battery.

Proper Battery Disposal

Warning: Handle used batteries carefully. Do not damage the battery in any way; a damaged battery may release hazardous materials into the environment. Do not discard a used battery in the garbage or a public landfill. Comply with the regulations set up by your local hazardous waste management agency to dispose of your used battery properly.

Battery Installation

1. To install an onboard battery, follow steps 1 and 2 above and continue below:
2. Identify the battery's polarity. The positive (+) side should be facing up.
3. Insert the battery into the battery holder and push it down until you hear a click to ensure that the battery is securely locked.

Warning: When replacing a battery, be sure to only replace it with the same type.

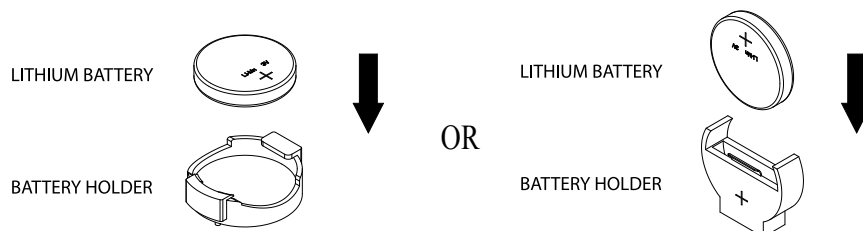

3.5 Returning Merchandise for Service

A receipt or copy of your invoice marked with the date of purchase is required before any warranty service will be rendered. You can obtain service by calling your vendor for a Returned Merchandise Authorization (RMA) number. When returning the motherboard to the manufacturer, the RMA number should be prominently displayed on the outside of the shipping carton, and the shipping package is mailed prepaid or hand-carried. Shipping and handling charges will be applied for all orders that must be mailed when service is complete. For faster service, you can also request a RMA authorization online (<http://www.supermicro.com/RmaForm/>).

This warranty only covers normal consumer use and does not cover damages incurred in shipping or from failure due to the alternation, misuse, abuse or improper maintenance of products.

During the warranty period, contact your distributor first for any product problems.

Chapter 4

UEFI BIOS

4.1 Introduction

This chapter describes the AMIBIOS™ Setup utility for the motherboard. The BIOS is stored on a chip and can be easily upgraded using a flash program.

 **Note:** Due to periodic changes to the BIOS, some settings may have been added or deleted and might not yet be recorded in this manual. Refer to the Manual Download area of our website for any changes to the BIOS that may not be reflected in this manual.

Starting the Setup Utility

To enter the BIOS Setup Utility, hit the <Delete> key while the system is booting-up. (In most cases, the <Delete> key is used to invoke the BIOS setup screen. There are a few cases when other keys are used, such as <F1>, <F2>, etc.) Each main BIOS menu option is described in this manual.

The Main BIOS screen has two main frames. The left frame displays all the options that can be configured. “Grayed-out” options cannot be configured. The right frame displays the key legend. Above the key legend is an area reserved for a text message. When an option is selected in the left frame, it is highlighted in white. Often a text message will accompany it. (Note that the BIOS has default text messages built in. We retain the option to include, omit, or change any of these text messages.) Settings printed in **Bold** are the default values.

A " ►" indicates a submenu. Highlighting such an item and pressing the <Enter> key will open the list of settings within that submenu.

The BIOS setup utility uses a key-based navigation system called hot keys. Most of these hot keys (<F1>, <F2>, <F3>, <Enter>, <ESC>, <Arrow> keys, etc.) can be used at any time during the setup navigation process.

4.2 Main Setup

When you first enter the AMI BIOS setup utility, you will enter the Main setup screen. You can always return to the Main setup screen by selecting the Main tab on the top of the screen. The Main BIOS setup screen is shown below and the following items will be displayed:

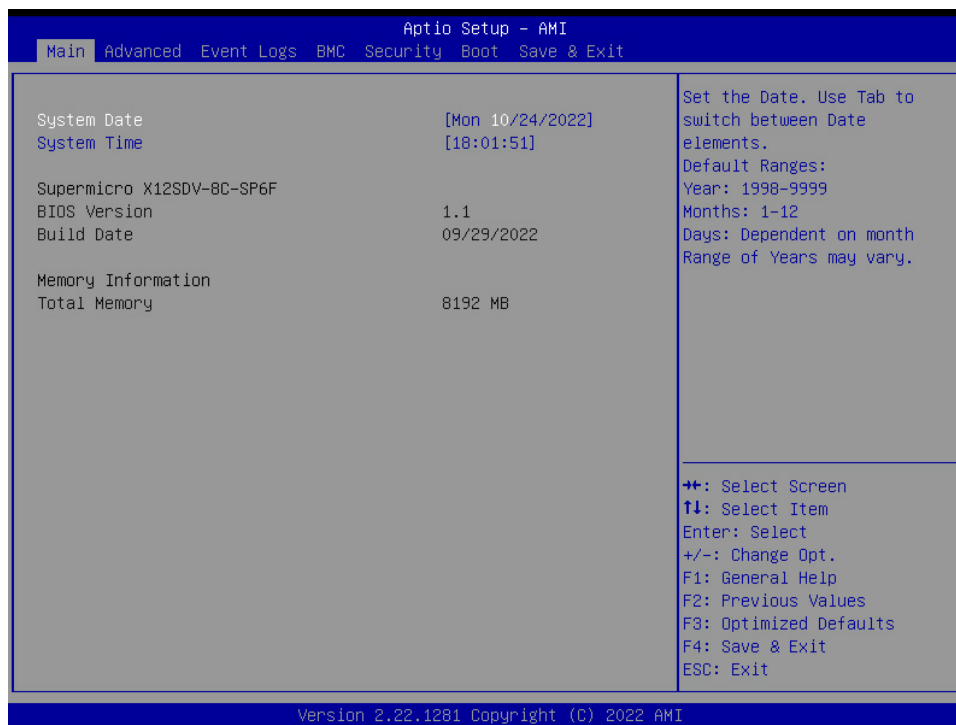

System Date/System Time

Use this option to change the system date and time. Highlight System Date or System Time using the arrow keys. Enter new values using the keyboard. Press the <Tab> key or the arrow keys to move between fields. The date must be entered in MM/DD/YYYY format. The time is entered in HH:MM:SS format.

 **Note:** The time is in the 24-hour format. For example, 5:30 P.M. appears as 17:30:00. The date's default value is the BIOS build date after RTC reset.

Supermicro X12SDV

BIOS Version

This item displays the version of the BIOS ROM used in the system.

Build Date

This item displays the date when the version of the BIOS ROM used in the system was built.

Memory Information

Total Memory

This item displays the total size of memory available in the system.

4.3 Advanced

Use the arrow keys to select the Advanced menu and press <Enter> to access the menu items:

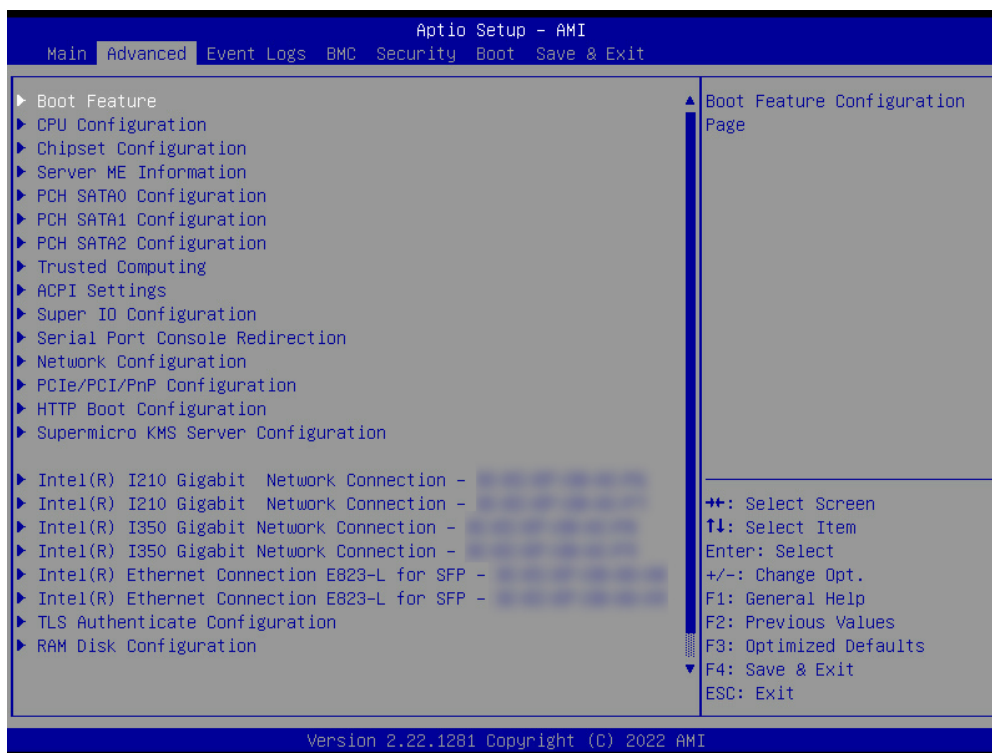

Warning: Take caution when changing the Advanced settings. An incorrect value, a very high DRAM frequency, or an incorrect DRAM timing setting may make the system unstable. When this occurs, revert to default manufacturer settings.

► Boot Feature

Quiet Boot

Use this feature to select the screen display between the POST messages and the OEM logo upon boot up. Select Disabled to display the POST messages. Select Enabled to display the OEM logo instead of the normal POST messages. The options are Disabled and **Enabled**.

Bootup NumLock State

Use this feature to set the Power-on state for the <Numlock> key. The options are **On** and Off.

Wait For "F1" If Error

Use this feature to force the system to wait until the <F1> key is pressed if an error occurs. The options are **Disabled** and Enabled.

Re-try Boot

If this feature is enabled, the BIOS automatically reboots the system from a specified boot device after its initial boot failure. The options are **Disabled** and EFI Boot.

Power Configuration

Watch Dog Function

If enabled, the Watch Dog Timer allows the system to reset or generate NMI when it has expired for more than five minutes. The options are **Disabled** and Enabled.

Front USB Port(s)

Use this feature to enable or disable front USB ports. The options are **Enabled**, Disabled, and Enabled (Dynamic).

Rear USB Port(s)

Use this feature to enable or disable rear USB ports. The options are **Enabled**, Disabled, and Enabled (Dynamic).

Restore on AC Power Loss

Use this feature to set the power state after a power outage. Select Stay Off for the system power to remain off after a power loss. Select Power On for the system power to be turned on after a power loss. Select Last State to allow the system to resume its last power state before a power loss. The options are Stay Off, Power On, and **Last State**.

Power Button Function

This feature controls how the system shuts down when the power button is pressed. Select 4 Seconds Override for you to power off the system after pressing and holding the power button for four seconds or longer. Select Instant Off to instantly power off the system as soon as you press the power button. The options are **Instant Off** and 4 Seconds Override.

►CPU Configuration

The following CPU information is displayed:

- Processor BSP Revision
- Processor Socket
- Processor ID
- Processor Frequency
- Processor Max Ratio
- Processor Min Ratio

- Microcode Revision
- L1 Cache RAM (Per Core)
- L2 Cache RAM (Per Core)
- L3 Cache RAM (Per Package)
- Processor 0 Version

▶ CPU1 Core Disable Bitmap

CPU1 Core Disable Bitmap

Available Bitmap

CPU Core Count

CPU1 Cores Enable

Use this feature to input how many CPU cores to enable. Input 0 to enable all cores. At least one core must be enabled.

Hyper-Threading (ALL)

Select Enable to support Intel Hyper-threading Technology to enhance CPU performance. The options are Disable and **Enable**.

Hardware Prefetcher

If set to Enable, the hardware prefetcher prefetches streams of data and instructions from the main memory to the L2 cache to improve CPU performance. The options are **Enable** and Disable.

Adjacent Cache Prefetch

The CPU prefetches the cache line for 64 bytes if this feature is set to Disabled. The CPU prefetches both cache lines for 128 bytes as comprised if this feature is set to Enable. The options are **Enable** and Disable.

DCU Streamer Prefetcher (Available when supported by the CPU)

Select Enable to enable the Data Cache Unit (DCU) Streamer Prefetcher, which streams and prefetches data and send it to the Level 1 data cache to improve data processing and system performance. The options are **Enable** and Disable.

DCU IP Prefetcher (Available when supported by the CPU)

Select Enable for Data Cache Unit (DCU) IP Prefetcher support, which prefetches IP addresses to improve network connectivity and system performance. The options are **Enable** and Disable.

LLC Prefetch

If set to Enable, the hardware prefetcher prefetches streams of data and instructions from the main memory to the L3 cache to improve CPU performance. The options are **Disable** and Enable.

Extended APIC

Select Enable to activate Advanced Programmable Interrupt Controller (APIC) support. The options are **Disable** and Enable.

Enable Intel(R) TXT

Use this feature to enable or disable Intel Trusted Execution Technology support. The options are **Disable** and Enable.

VMX

Use this feature to enable or disable Vanderpool Technology. The options are Disable and **Enable**.

Enable SMX

Use this feature to enable or disable Safer Mode Extensions. The options are **Disable** and Enable.

PPIN Control

Select Unlock/Enable to use the Protected Processor Inventory Number (PPIN) in the system. The options are Lock/Disable and **Unlock/Enable**.

AES-NI

Select Enable to use the Intel Advanced Encryption Standard (AES) New Instructions (NI) to ensure data security. The options are Disable and **Enable**.

TME, TME-MT**Total Memory Encryption (TME)**

Use this feature to enable or disable total memory encryption. The options are **Disabled** and Enabled.

****If the feature above is set to Enabled, the next six features are displayed:***

Total Memory Encryption Multi-Tenant (TME-MT)

Max TME-MT Keys

Software Guard Extension (SGX)

SGX Factory Reset

SW Guard Extensions (SGX)

SGX Package Into In-Band Access

Limit CPU PA to 46 Bits

Use this feature to limit the CPU physical address to 46 bits to support older Hyper-V. The options are Disable and **Enable**.

▶ Advanced Power Management Configuration

Power Performance Tuning

Use this feature to select whether the BIOS or the operating system chooses energy performance tuning. The options are **OS Controls EPB** and BIOS Controls EPB.

****If the feature above is set to BIOS Controls EPB, the next feature is available for configuration:***

ENERGY_PERF_BIAS CFG Mode

Use this feature to set the energy performance bias. The options are Maximum Performance, Performance, **Balanced Performance**, Balanced Power, and Power.

▶ CPU P State Control

SpeedStep (Pstates)

Intel SpeedStep Technology allows the system to automatically adjust processor voltage and core frequency to reduce power consumption and heat dissipation. The options are Disable and **Enable**.

AVX P1

Use this feature to select the AVX-P1 level. The options are **Normal**, Level 1, and Level 2.

EIST PSD Function

This feature allows you to choose between Hardware and Software to control the processor's frequency and performance (P-state). In HW_ALL mode, the processor hardware is responsible for coordinating the P-state, and the OS is responsible for keeping the P-state request up to date on all Logical Processors. In SW_ALL mode, the OS Power Manager is responsible for coordinating the P-state, and must initiate the transition on all Logical Processors. The options are **HW_ALL** and **SW_ALL**.

Turbo Mode

This feature enables dynamic control of the processor, allowing it to run above stock frequency. The options are Disable and **Enable**.

▶ Hardware PM State Control

Hardware P-States

This setting allows you to select between OS and hardware-controlled P-states. Selecting Native Mode allows the OS to choose a P-state. Selecting Out of Band Mode allows the hardware to autonomously choose a P-state without OS guidance. Selecting Native Mode with No Legacy Support functions as Native Mode with no support for older hardware. The options are **Disable**, Native Mode, Out of Band Mode, and Native Mode with No Legacy Support.

▶ Frequency Prioritization

RAPL Prioritization

Use this feature to enable the RAPL balancer. The options are Enable and **Disable**.

▶ CPU C State Control

Enable Monitor MWAIT

Select Enabled to enable the Monitor/Mwait instructions. The Monitor instructions monitors a region of memory for writes, and MWait instructions instruct the CPU to stop until the monitored region begins to write. The options are Disable and **Enable**.

CPU C6 Report

Select Enable to allow the BIOS to report the CPU C6 State (ACPI C3) to the operating system. During the CPU C6 State, the power to all cache is turned off. The options are Disable, Enable, and **Auto**.

Enhanced Halt State (C1E)

Select Enable to use Enhanced Halt State technology, which significantly reduces the CPU's power consumption by reducing its clock cycle and voltage during a Halt-state. The options are Disable and **Enable**.

► Package C State Control

Package C State

This feature allows you to set the limit on the C State package register. The options are C0/C1 state, C2 state, C6(non Retention) state, and **Auto**.

► CPU T State Control

Software Controlled T-States

Use this feature to enable Software Controlled T-States. The options are **Disable** and Enable.

If the feature above is set to Enable, the next feature is available for configuration:

T-State Throttle Level

Use this feature to enable or disable CPU throttling, which reduces power consumption. The options are **Disable**, 6.25%, 12.5%, 18.75%, 25.0%, 31.25%, 37.5%, 43.75%, 50.0%, 56.25%, 62.5%, 68.75%, 75.0%, 81.25%, 87.5%, and 93.75%.

▶ Chipset Configuration

Warning: Setting the wrong values in the following features may cause the system to malfunction.

▶ North Bridge

▶ Uncore Configuration

Uncore Configuration

- Number of CPU
- Number of IIO
- Current UPI Link Speed
- Current UPI Link Frequency
- Global MMIO Low Base / Limit
- Global MMIO High Base / Limit
- PCIe Configuration Base / Size

XPT Prefetch

Use this feature to enable or disable XPT Prefetch support, which allows an LLC request to be duplicated and sent to an appropriate memory controller based on the recent LLC history to reduce latency. The options are Disable, Enable, and **Auto**.

PCIe Remote P2P Relaxed Ordering

Enable peer-to-peer relaxed ordering to optimize system performance. The options are **Disable** and Enable.

Stale AtoS

Use this feature to enable or disable Stale A to S optimization. There are three states in the in-memory directory: invalid (I), snoopAll (A), and shared (S). Data in the I state is clean and does not exist in other sockets. Data in the A state may exist in another exclusive or modified socket. Data in the S state is clean and may be shared across one or more sockets. The options are Disable, Enable, and **Auto**.

LLC Dead Line Alloc

Select Enable to opportunistically fill dead lines in the LLC. Select Disable to never fill dead lines in LLC. The options are Disable, **Enable**, and Auto.

▶ Memory Configuration

Enforce POR

Select Plan of Record (POR) to enforce POR restrictions on DDR4 frequency and voltage programming. The options are **POR** and Disable.

PPR Type

Use this feature to select the Post Package Repair (PPR) type. The options are PPR Disabled, **Hard PPR**, and Soft PPR.

Memory Frequency

Use this feature to set the maximum memory frequency for onboard memory modules. The options are **Auto**, 2133, 2200, 2400, 2600, 2666, 2800, 2933, 3000, and 3200.

Data Scrambling for DDR4

Use this feature to enable or disable data scrambling for DDR4 memory. The options are Disable and **Enable**.

2x Refresh Enable

Use this feature to enable 2x memory refresh support to enhance memory performance. The options are **Auto**, Disable, and Enable.

▶ Memory Topology

This feature displays the information of memory modules detected by the BIOS.

▶ Memory RAS Configuration Setup

Enabled Pcode WA for SAI PG

Use this feature to enable Pcode Work Around for SAI Policy group for A Step. The options are **Disabled** and Enabled.

Mirror Mode

This feature allows memory to be mirrored between two channels, providing 100% redundancy. The options are **Disable**, Full Mirror Mode, and Partial Mirror Mode.

Correctable Error Threshold

Use this feature to specify the threshold value for correctable memory-error logging, which sets a limit on the maximum number of events that can be logged in the memory error log at a given time. The default setting is **512**.

Leaky Bucket Low Bit

Use this feature to set the Low Bit value for the Leaky Bucket algorithm, which is used to check the data transmissions between the CPU socket and the memory controller. The default setting is **13**.

Leaky Bucket High Bit

Use this feature to set the High Bit value for the Leaky Bucket algorithm, which is used to check the data transmissions between the CPU socket and the memory controller. The default setting is **14**.

Partial Cache Line Sparing PCLS

Use this feature to enable or disable Partial Cache Line Sparing (PCLS). The options are Disabled and **Enabled**.

ADDDC Sparing

Adaptive Double Device Data Correction (ADDDC) Sparing detects when the predetermined threshold for correctable errors is reached, copying the contents of the failing DIMM to spare memory. The failing DIMM or memory rank will then be disabled. The options are Disabled and **Enabled**.

Patrol Scrub

Patrol Scrubbing is a process that allows the CPU to correct correctable memory errors detected on a memory module and send the correction to the requestor (the original source). When this item is set to Enable, the IO hub reads and writes back one cache line every 16K cycles if there is no delay caused by internal processing. By using this method, roughly 64 GB of memory behind the IO hub is scrubbed every day. The options are Disabled, Enabled, and **Enable at End of POST**.

► I/O Configuration**► CPU1 Configuration****SMCI AOC Auto Detect**

Use this feature to configure the SMCI AOC Auto Detect function. When Auto Detect is enabled, Slot 6 will be turned off. The options are **Disable** and Enable.

PCIe Slot6

Use this feature to enable or disable PCIe Slot6. The options are **Enable** and Disable.

IOU0 (IIO PCIe Port 1)

Use this feature to configure the PCIe Bifurcation setting for IIO PCIe Port 1. The setting in PCIe Slot6 affects the options shown in this feature. When PCIe Slot6 is set to Enable, the options are Slot7:X4X4, Slot6:X4X4; Slot7:X4X4, Slot6:X8; Slot7:X8, Slot6:X4X4; and **Slot7:X8, Slot6:X8**. When PCIe Slot6 is set to Disable, the options are Slot7:X4X4X4X4, Slot7:X4X4X8, Slot7:X8X4X4, **Slot7:X8X8**, and Slot7:X16.

► IOAT Configuration

Disable TPH

Transparent Huge Pages (TPH) is a Linux memory management system that enables communication in larger blocks (pages). Enabling this feature increases performance. The options are **No** and Yes.

****If the feature above is set to No, the feature below is available for configuration:***

Prioritize TPH

Use this feature to enable Prioritize TPH support. The options are Enable and **Disable**.

Relaxed Ordering

Select Yes to enable Relaxed Ordering support, which allows certain transactions to violate the strict-ordering rules of PCI bus for a transaction to be completed prior to other transactions that have already been enqueued. The options are **No** and Yes.

► Intel(R) VT for Directed I/O (VT-d)

Intel® VT for Directed I/O (VT-d)

Select Enable to use Intel Virtualization Technology for Direct I/O VT-d support by reporting the I/O device assignments to the Virtual Machine Monitor (VMM) through the DMAR ACPI tables. This feature offers fully-protected I/O resource sharing across Intel platforms, providing greater reliability, security and availability in networking and data sharing. The options are **Enable** and Disable.

ACS Control

Select Enable to program Access Control Services (ACS) to the chipset PCIe root port bridge. Select No to program ACS to all PCIe root port bridges. The options are **Enable** and Disable.

Interrupt Remapping

Use this feature to enable Interrupt Remapping support, which detects and controls external interrupt requests. The options are **Auto**, Enable, and Disable.

▶ Intel(R) VMD Technology

▶ Intel(R) VMD Technology

Intel® VMD Technology

NVMe Mode Switch

Use this feature to select the NVMe mode. The options are Manual, VMD, and **Auto**.

**If the feature above is set to Manual, the following features are available for configuration:*

▶ Intel(R) VMD for Volume Management Device on CPU1

VMD Config for PCH ports

Enable/Disable VMD

Use this feature to enable or disable the volume management device for this stack. The options are **Disable** and Enable.

**If the feature above is set to Enable, the following features are available for configuration:*

JMD2:M.2-H PCIe 3.0 X2 3.0 VMD

Use this feature to enable or disable hot plug for this port. The options are **Disable** and Enable.

NVME/SAS #0 VMD

Use this feature to enable or disable hot plug for this port. The options are **Disable** and Enable.

NVME/SAS #1 VMD

Use this feature to enable or disable hot plug for this port. The options are **Disable** and Enable.

JMD1:M.2-H PCIe 3.0 X4 3.0 VMD

Use this feature to enable or disable hot plug for this port. The options are **Disable** and Enable.

M.2-H PCIe 3.0 X1 VMD

Use this feature to enable or disable hot plug for this port. The options are **Disable** and Enable.

VMD Config for IOU 0

Enable/Disable VMD

Use this feature to enable or disable the volume management device for this stack. The options are **Disable** and Enable.

If the feature above is set to Enable, the following features are available for configuration:

CPU PCIe 4.0 x16 Port A VMD

Use this feature to enable or disable VMD technology for this port. The options are **Disable** and Enable.

CPU PCIe 4.0 x16 Port B VMD

Use this feature to enable or disable VMD technology for this port. The options are **Disable** and Enable.

CPU PCIe 4.0 x16 Port C VMD

Use this feature to enable or disable VMD technology for this port. The options are **Disable** and Enable.

CPU PCIe 4.0 x16 Port D VMD

Use this feature to enable or disable VMD technology for this port. The options are **Disable** and Enable.

Hot Plug Capable

Use this feature to enable or disable hot plug for this port. The options are **Disable** and Enable.

IIO eDPC Support

Use this feature to enable or disable IIO enhanced DPC support. The options are **Disable**, On Fatal Error, and On Fatal and Non-Fatal Errors.

**If the feature above is set to On Fatal Error or On Fatal and Non-Fatal Errors, the next two features are available for configuration:*

IIO eDPC Interrupt

Use this feature to enable or disable IIO enhanced DPC interrupt. The options are Disable and **Enable**.

IIO eDPC ERR_COR Message

Use this feature to enable or disable IIO enhanced DPC error correction message. The options are Disable and **Enable**.

PCIe ASPM Support (Global)

Use this feature to enable to disable ASPM support for all downstream devices. The options are **Disable** and Auto.

► South Bridge

The following USB information is displayed:

- USB Module Version
- USB Devices

XHCI Hand-off

When this feature is disabled, the motherboard will not support USB 3.0. The options are **Enabled** and Disabled.

PCIe PLL SSC

Use this feature to enable or disable PCIe PLL SSC. The options are **Disabled** and Enabled.

► Server ME Information

The following General ME Configuration is displayed:

- General ME Configuration
- Oper. Firmware Version

- Backup Firmware Version
- Recovery Firmware Version
- ME Firmware Status #1
- ME Firmware Status #2
- Current State
- Error Code

► PCH SATA0 Configuration

SATA Controller 0

This feature enables or disables the onboard SATA controller supported by the Intel PCH chip. The options are Disable and **Enable**.

SATA Mode Selection

Select AHCI to configure a SATA drive specified as an AHCI drive. Select RAID to configure an sSATA drive specified as a RAID drive. The options are **AHCI** and RAID.

Support Aggressive Link Power Management

When this feature is set to Enable, the SATA AHCI controller manages the power usage of the SATA link. The controller puts the link in a low power mode during extended periods of I/O inactivity, and returns the link to an active state when I/O activity resumes. The options are **Disable** and Enable.

SATA SGPIO/LED

Select SGPIO to enable SGPIO. Select SATA LED to enable the SATA LED. The options are SGPIO and **SATA LED**.

SATA Port 1/3/6/7

This feature displays the information detected on the installed SATA drive on the particular SATA port.

- Software Preserve Support

SATA Port 1/3/6/7 Hot Plug

Set this feature to Enable for hot plug support, which allows you to replace a SATA drive without shutting down the system. The options are Disable and **Enable**.

SATA Port 1/3/6/7 Spin Up Device

Set this feature to enable or disable the PCH to initialize the device. The options are **Disable** and **Enable**.

SATA Port 1/3/6/7 SATA Device Type

Use this feature to specify if the SATA port specified should be connected to a Solid State Drive or a Hard Disk Drive. The options are **Hard Disk Drive** and **Solid State Drive**.

► PCH SATA1 Configuration**► PCH SATA2 Configuration****SATA Controller**

This feature enables or disables the onboard SATA controller supported by the Intel PCH chip. The options are **Disable** and **Enable**.

SATA Mode Selection

Select AHCI to configure a SATA drive specified as an AHCI drive. Select RAID to configure an sSATA drive specified as a RAID drive. The options are **AHCI** and **RAID**.

Support Aggressive Link Power Management

When this feature is set to **Enable**, the SATA AHCI controller manages the power usage of the SATA link. The controller puts the link in a low power mode during extended periods of I/O inactivity, and returns the link to an active state when I/O activity resumes. The options are **Disable** and **Enable**.

SATA Port 0 – 7

This feature displays the information detected on the installed SATA drive on the particular SATA port.

- Software Preserve Support

SATA Port 0 – 7 Hot Plug

Set this feature to **Enable** for hot plug support, which allows you to replace a SATA drive without shutting down the system. The options are **Disable** and **Enable**.

SATA Port 0 – 7 Spin Up Device

Set this feature to enable or disable the PCH to initialize the device. The options are **Disable** and **Enable**.

SATA Port 0 – 7 SATA Device Type

Use this feature to specify if the SATA port specified should be connected to a Solid State Drive or a Hard Disk Drive. The options are **Hard Disk Drive** and **Solid State Drive**.

▶ Trusted Computing

The following Trusted Platform Module (TPM) information will display if a TPM 2.0 module is detected:

- Firmware Version
- Vendor Name

Security Device Support

If this feature and the TPM jumper on the motherboard are both set to Enabled, onboard security devices will be enabled for Trusted Platform Module (TPM) support to enhance data integrity and network security. Reboot the system for a change on this setting to take effect. The options are Disable and **Enable**.

- Active PCR Banks
- Available PCR banks

****If the feature above is set to Enable, "SHA-1 PCR Bank" and "SHA256 PCR Bank" will become available for configuration:***

SHA-1 PCR Bank

Use this feature to disable or enable the SHA-1 Platform Configuration Register (PCR) bank for the installed TPM device. The options are Disabled and **Enabled**.

SHA256 PCR Bank

Use this feature to disable or enable the SHA256 Platform Configuration Register (PCR) bank for the installed TPM device. The options are Disabled and **Enabled**.

Pending Operation

Use this feature to schedule a TPM-related operation to be performed by a security device for system data integrity. Your system will reboot to carry out a pending TPM operation. The options are **None** and TPM Clear.

Platform Hierarchy

Use this feature to disable or enable platform hierarchy for platform protection. The options are Disabled and **Enabled**.

Storage Hierarchy

Use this feature to disable or enable storage hierarchy for cryptographic protection. The options are Disabled and **Enabled**.

Endorsement Hierarchy

Use this feature to disable or enable endorsement hierarchy for privacy control. The options are Disabled and **Enabled**.

PH Randomization

Use this feature to disable or enable Platform Hierarchy (PH) Randomization. The options are **Disabled** and Enabled.

▶ACPI Settings

WHEA Support

Select Enabled to support the Windows Hardware Error Architecture (WHEA) platform and provide a common infrastructure for the system to handle hardware errors within the Windows OS environment to reduce system crashes and to enhance system recovery and health monitoring. The options are Disabled and **Enabled**.

Headless Support

Enable this feature to grant control of PCI Express Native hot plug, PCI Express Power Management Events, and PCI Express Capability Structure Control. The options are **Disabled** and Enabled.

High Precision Event Timer

Select Enabled to activate the High Precision Event Timer (HPET) that produces periodic interrupts at a much higher frequency than a Real-time Clock (RTC) does in synchronizing multimedia streams, providing smooth playback and reducing the dependency on other timestamp calculation devices, such as an x86 RDTSC Instruction embedded in the CPU. The High Performance Event Timer is used to replace the 8254 Programmable Interval Timer. The options are Disabled and **Enabled**.

RTC Wake System from S4/S5

Enable this feature to grant control of PCI Express Native hot plug, PCI Express Power Management Events, and PCI Express Capability Structure Control. The options are **Disabled** and Enabled.

► Super IO Configuration

The following Super IO information is displayed:

- Super IO Chip AST2600

► Serial Port 1 Configuration

Serial Port

Select Enabled to enable the selected onboard serial port. The options are Disabled and **Enabled**.

Device Settings

This feature displays the status of the specified serial port.

Change Settings

This feature specifies the base I/O port address and the Interrupt Request address of the specified serial port. Select Auto to allow the BIOS to automatically assign the base I/O and IRQ address. The options are **Auto**, (IO=3F8h; IRQ=4;), (IO=2F8h; IRQ=4;), (IO=3E8h; IRQ=4;), and (IO=2E8h; IRQ=4;).

► Serial Port 2 Configuration

Serial Port

Select Enabled to enable the selected onboard serial port. The options are Disabled and **Enabled**.

Device Settings

This feature displays the status of the specified serial port.

Change Settings

This feature specifies the base I/O port address and the Interrupt Request address of the specified serial port. Select Auto to allow the BIOS to automatically assign the base I/O and IRQ address. The options are **Auto**, (IO=3F8h; IRQ=3;), (IO=2F8h; IRQ=3;), (IO=3E8h; IRQ=3;), and (IO=2E8h; IRQ=3;).

► Serial Port Console Redirection

COM1 Console Redirection

Select Enabled to enable console redirection support for the specified serial port. The options are Enabled and **Disabled**.

**If the feature above is set to Enabled, the following features will be available for configuration:*

► COM1 Console Redirection Settings

Use this feature to specify how the host computer will exchange data with the client computer, which is the remote computer.

COM1 Terminal Type

This feature allows you to select the target terminal emulation type for Console Redirection. Select VT100 to use the ASCII Character set. Select VT100+ to add color and function key support. Select ANSI to use the Extended ASCII Character Set. Select VT-UTF8 to use UTF8 encoding to map Unicode characters into one or more bytes. The options are VT100, **VT100+**, VT-UTF8, and ANSI.

COM1 Bits Per Second

Use this feature to set the transmission speed for a serial port used in Console Redirection. Make sure that the same speed is used in the host computer and the client computer. A lower transmission speed may be required for long and busy lines. The options are 9600, 19200, 38400, 57600, and **115200** (bits per second).

COM1 Data Bits

Use this feature to set the data transmission size for Console Redirection. The options are 7 Bits and **8 Bits**.

COM1 Parity

A parity bit can be sent along with regular data bits to detect data transmission errors. Select Even if the parity bit is set to 0, and the number of 1's in data bits is even. Select Odd if the parity bit is set to 0, and the number of 1's in data bits is odd. Select None if you do not want to send a parity bit with your data bits in transmission. Select Mark to add a mark as a parity bit to be sent along with the data bits. Select Space to add a Space as a parity bit to be sent with your data bits. The options are **None**, Even, Odd, Mark, and Space.

COM1 Stop Bits

A stop bit indicates the end of a serial data packet. Select 1 Stop Bit for standard serial data communication. Select 2 Stop Bits if slower devices are used. The options are **1** and 2.

COM1 Flow Control

Use this feature to set the flow control for Console Redirection to prevent data loss caused by buffer overflow. Send a "Stop" signal to stop sending data when the receiving buffer is full. Send a "Start" signal to start sending data when the receiving buffer is empty. The options are **None** and Hardware RTS/CTS.

COM1 VT-UTF8 Combo Key Support

Select Enabled to enable VT-UTF8 Combination Key support for ANSI/VT100 terminals. The options are Disabled and **Enabled**.

COM1 Recorder Mode

Select Enabled to capture the data displayed on a terminal and send it as text messages to a remote server. The options are **Disabled** and Enabled.

COM1 Resolution 100x31

Select Enabled for extended-terminal resolution support. The options are Disabled and **Enabled**.

COM1 Putty KeyPad

This feature selects the settings for Function Keys and KeyPad used for Putty, which is a terminal emulator designed for the Windows OS. The options are **VT100**, LINUX, XTERMR6, SC0, ESCN, and VT400.

COM1 Redirection After BIOS POST

Use this feature to enable or disable legacy console redirection after BIOS POST. When set to Bootloader, legacy console redirection is disabled before booting the OS. When set to Always Enable, legacy console redirection remains enabled when booting the OS. The options are **Always Enable** and Bootloader.

SOL Console Redirection

Select Enabled to use the port for Console Redirection. The options are Disabled and **Enabled**.

****If the feature above is set to Enabled, the following features will become available for configuration:***

► SOL Console Redirection Settings

SOL Terminal Type

Use this feature to select the target terminal emulation type for Console Redirection. Select VT100 to use the ASCII Character set. Select VT100+ to add color and function key support. Select ANSI to use the Extended ASCII Character Set. Select VT-UTF8 to use UTF8 encoding to map Unicode characters into one or more bytes. The options are VT100, **VT100+**, VT-UTF8, and ANSI.

SOL Bits per second

Use this feature to set the transmission speed for a serial port used in Console Redirection. Make sure that the same speed is used in the host computer and the client computer. A lower transmission speed may be required for long and busy lines. The options are 9600, 19200, 38400, 57600, and **115200** (bits per second).

SOL Data Bits

Use this feature to set the data transmission size for Console Redirection. The options are 7 Bits and **8 Bits**.

SOL Parity

A parity bit can be sent along with regular data bits to detect data transmission errors. Select Even if the parity bit is set to 0, and the number of 1's in data bits is even. Select Odd if the parity bit is set to 0, and the number of 1's in data bits is odd. Select None if you do not want to send a parity bit with your data bits in transmission. Select Mark to add a mark as a parity bit to be sent along with the data bits. Select Space to add a Space as a parity bit to be sent with your data bits. The options are **None**, Even, Odd, Mark, and Space.

SOL Stop Bits

A stop bit indicates the end of a serial data packet. Select 1 Stop Bit for standard serial data communication. Select 2 Stop Bits if slower devices are used. The options are **1** and 2.

SOL Flow Control

Use this feature to set the flow control for Console Redirection to prevent data loss caused by buffer overflow. Send a "Stop" signal to stop sending data when the receiving buffer is full. Send a "Start" signal to start sending data when the receiving buffer is empty. The options are **None** and Hardware RTS/CTS.

SOL VT-UTF8 Combo Key Support

Select Enabled to enable VT-UTF8 Combination Key support for ANSI/VT100 terminals. The options are Disabled and **Enabled**.

SOL Recorder Mode

Select Enabled to capture the data displayed on a terminal and send it as text messages to a remote server. The options are **Disabled** and Enabled.

SOL Resolution 100x31

Select Enabled for extended-terminal resolution support. The options are Disabled and **Enabled**.

SOL Putty KeyPad

This feature selects Function Keys and KeyPad settings for Putty, which is a terminal emulator designed for the Windows OS. The options are **VT100**, LINUX, XTERMR6, SCO, ESCN, and VT400.

SOL Redirection After BIOS POST

Use this feature to enable or disable legacy Console Redirection after BIOS POST. When set to Bootloader, legacy Console Redirection is disabled before booting the OS. When set to Always Enable, legacy Console Redirection remains enabled when booting the OS. The options are **Always Enable** and Bootloader.

Serial Port for Out-Of-Band-Management/Windows Emergency Management Services (EMS)

Select Enabled to use a COM port for EMS Console Redirection. The options are Enabled and **Disabled**.

****If the feature above is set to Enabled, the following features will become available for configuration:***

► EMS Console Redirection Settings

This feature allows you to specify how the host computer will exchange data with the client computer, which is the remote computer.

Out-of-Band Mgmt Port

The feature selects a serial port in a client server to be used by the Microsoft Windows Emergency Management Services (EMS) to communicate with a remote host server. The options are **COM1** and SOL.

Terminal Type

Use this feature to select the target terminal emulation type for Console Redirection. Select VT100 to use the ASCII character set. Select VT100+ to add color and function key support. Select ANSI to use the extended ASCII character set. Select VT-UTF8 to use UTF8 encoding to map Unicode characters into one or more bytes. The options are VT100, VT100+, **VT-UTF8**, and ANSI.

Bits Per Second

This feature sets the transmission speed for a serial port used in Console Redirection. Make sure that the same speed is used in the host computer and the client computer. A lower transmission speed may be required for long and busy lines. The options are 9600, 19200, 57600, and **115200** (bits per second).

Flow Control

Use this feature to set the flow control for Console Redirection to prevent data loss caused by buffer overflow. Send a "Stop" signal to stop sending data when the receiving buffer is full. Send a "Start" signal to start sending data when the receiving buffer is empty. The options are **None**, Hardware RTS/CTS, and Software Xon/Xoff.

Data Bits EMS**Parity EMS****Stop Bits EMS****► Network Configuration****Network Stack**

Select Enabled to enable Preboot Execution Environment (PXE) or Unified Extensible Firmware Interface (UEFI) for network stack support. The options are Disabled and **Enabled**.

IPv4 PXE Support

Select Enabled to enable IPv4 PXE boot support. The options are Disabled and **Enabled**.

IPv4 HTTP Support

Select Enabled to enable IPv4 HTTP boot support. The options are **Disabled** and Enabled.

IPv6 PXE Support

Select Enabled to enable IPv6 PXE boot support. The options are **Disabled** and Enabled.

IPv6 HTTP Support

Select Enabled to enable IPv6 HTTP boot support. The options are **Disabled** and Enabled.

PXE Boot Wait Time

Use this option to specify the wait time to press the <ESC> key to abort the PXE boot. Press <+> or <-> on your keyboard to change the value. The default setting is **0**.

Media Detect Count

Use this option to specify the number of times media is checked. Press <+> or <-> on your keyboard to change the value. The default setting is **1**.

▶ MAC::xxxxxxxxxxx-IPv4 Network Configuration
▶ MAC::xxxxxxxxxxx-IPv4 Network Configuration
▶ MAC::xxxxxxxxxxx-IPv4 Network Configuration
▶ MAC::xxxxxxxxxxx-IPv4 Network Configuration
▶ MAC::xxxxxxxxxxx-IPv4 Network Configuration
▶ MAC::xxxxxxxxxxx-IPv4 Network Configuration

Configured

Use this feature to indicate whether the network address is configured successfully or not. The options are **Disabled** and **Enabled**.

**If the feature above is set to Enabled, "Enable DHCP," "Local IP Address," "Local NetMask," "Local Gateway," and "Local DNS Servers" will become available for configuration:*

Enabled DHCP

Select **Enabled** to support Dynamic Host Configuration Protocol (DHCP). DHCP allows the BIOS to search for a DHCP server attached to the network and request the next available IP address for this computer. The options are **Disabled** and **Enabled**.

Local IP Address

Use this feature to enter an IP address for the local machine. This feature is unavailable when DHCP is enabled.

Local Network

Use this feature to set the network for the local machine. This feature is unavailable when DHCP is enabled.

Local Gateway

Use this feature to set the gateway address for the local machine. This feature is unavailable when DHCP is enabled.

Local DNS Servers

Use this feature to set the Domain Name System (DNS) server address for the local machine. This feature is unavailable when DHCP is enabled.

Save Changes and Exit

Select **Yes** to save the changes and exit, or **No** to exit without saving the changes.

- ▶ **MAC::xxxxxxxxxxx-IPv6 Network Configuration**
- ▶ **MAC::xxxxxxxxxxx-IPv6 Network Configuration**
- ▶ **MAC::xxxxxxxxxxx-IPv6 Network Configuration**
- ▶ **MAC::xxxxxxxxxxx-IPv6 Network Configuration**
- ▶ **MAC::xxxxxxxxxxx-IPv6 Network Configuration**
- ▶ **MAC::xxxxxxxxxxx-IPv6 Network Configuration**

▶ **Enter Configuration Menu**

Interface Name

Interface Type

MAC address

Host addresses

Route Table

Gateway addresses

DNS addresses

Interface ID

This feature shows the interface ID for the specified network device.

DAD Transmit Count

This feature sends Neighbor Solicitation messages while performing a Duplicate Address Detection (DAD) to make sure there is no IP address duplication. A value of zero means a DAD has not been performed.

Policy

Use this feature to select an automatic or manual policy. The options are **automatic** and **manual**.

Save Changes And Exit

When you have completed the changes for this section, select this option to save all changes made and exit.

▶ **PCIe/PCI/PnP Configuration**

PCI Bus Driver Version

PCI Devices Common Settings

Above 4G Decoding (Available if the system supports 64-bit PCI decoding)

Select Enabled to decode a PCI device that supports 64-bit in the space above 4G Address. The options are Disabled and **Enabled**.

SR-IOV Support

Use this feature to enable or disable Single Root IO Virtualization Support. The options are Disabled and **Enabled**.

ARI Support

Use this feature to enable or disable ARI support. The options are Disabled and **Enabled**.

Bus Master Enable

Use this feature to enable the Bus Master, which enables the Bus Master Attribute for DMA transaction. The options are Disabled and **Enabled**.

Consistent Device Name Support

This feature controls the device naming for network devices and slots. The options are **Disabled** and Enabled.

MMIO High Base

Use this feature to select the base memory size according to memory-address mapping for the IO hub. The options are 56T, 40T, 32T, 24T, 16T, 4T, **2T**, 1T, and 512 G.

MMIO High Granularity Size

Use this feature to select the high memory size according to memory-address mapping for the IO hub. The options are 1G, 4G, 16G, 64G, **256G**, and 1024G.

Maximum Read Request

Use this item to select the Maximum Read Request size of the PCIe device, or select Auto to allow the System BIOS to determine the value. The options are **Auto**, 128 Bytes, 256 Bytes, 512 Bytes, 1024 Bytes, 2048 Bytes, and 4096 Bytes.

MMCFG Base

Use this feature to select the low base address for PCIe adapters to increase base memory. The options are 1G, 1.5G, 1.75G, 2G, 2.25G, 3G, and **Auto**.

NVMe Firmware Source

The feature determines which type of NVMe firmware should be used in your system. The options are **Vendor Defined Firmware** and AMI Native Support.

VGA Priority

Use this feature to select VGA priority when multiple VGA devices are detected. Select Onboard to give priority to your onboard video device. Select Offboard to give priority to your graphics card. The options are **Onboard** and Offboard.

CPU SLOT7 PCIe 4.0 X16 OPROM

Use this feature to select which firmware type to be loaded for the add-on card in this slot. The options are Disabled and **EFI**.

CPU SLOT6 PCIe 4.0 X8 OPROM

Use this feature to select which firmware type to be loaded for the add-on card in this slot. The options are Disabled and **EFI**.

JMD2:M.2-H PCIe 3.0 X2/S-SATA 3.0 OPROM

Use this feature to select which firmware type to be loaded for the add-on card in this slot. The options are Disabled and **EFI**.

JMD1:M.2-H PCIe 3.0 X4/S-SATA 3.0 OPROM

Use this feature to select which firmware type to be loaded for the add-on card in this slot. The options are Disabled and **EFI**.

JMD3:M.2-H PCIe 3.0 X1 OPROM

Use this feature to select which firmware type to be loaded for the add-on card in this slot. The options are Disabled and **EFI**.

Onboard LAN1/2/3/4/5/6 Option ROM

Use this feature to select which firmware function to be loaded for LAN Port1 used for system boot. The options are Disabled and **EFI**.

Onboard Video Option ROM

Use this feature to select which firmware function to be loaded for LAN1 used for system boot. The options are Disabled and **EFI**.

▶ HTTP Boot Configuration**HTTP Boot Configuration****HTTP Boot Policy**

Use this feature to select the boot policy. The options are Apply to all LANs, **Apply to each LAN**, and Boot Priority #1 instantly.

HTTPS Boot Checks Hostname

Enable this feature to allow HTTPS Boot to check if the hostname of the TLS certificate matches the hostname provided by the remote server. Selecting Disabled is a violation of RFC6125. The options are **Enabled** and Disabled (WARNING: Security Risk!!).

Priority of HTTP Boot:

Instance of Priority 1:

Use this feature to set the rank target port. The default value is **1**.

Select IPv4 or IPv6

Use this feature to select which LAN port to boot from. The options are **IPv4** and IPv6.

Boot Description

Highlight the feature and press <Enter> to create a boot description. The description cannot be more than 75 characters.

Boot URI

Highlight the feature and press <Enter> to create a boot URI.

Instance of Priority 2/3/4

Use this feature to set the rank target port. The default value is **0**.

► Supermicro KMS Server Configuration

Supermicro KMS Server IP address

Use this feature to enter the Supermicro Key Management Service (KMS) server IPv4 address in dotted-decimal notation.

Second Supermicro KMS Server IP address

Use this feature to enter the second Supermicro KMS server IPv4 address in dotted-decimal notation.

Supermicro KMS TCP Port number

Use this feature to enter the Supermicro KMS TCP port number. The valid range is 100 – 9999. The default port is **5696**.

Supermicro KMS Time Out

Use this feature to enter the KMS server connecting time-out (in seconds). The default setting is **5** (seconds).

Supermicro KMS Server Retry Count

Use this feature to set how many attempts to connect to the Supermicro KMS Server. Enter 0 to retry infinitely. The default value is **2**.

TimeZone

Use this feature to set the time zone. A value of 0 is GMT+0. A value of 23 is GMT-1. The default value is **0**.

TCG Nvme KMS Policy

Use this feature to select the TCG NVMe KMS Policy. The options are Normal Unlock, **Do Nothing**, Reset All Devices, and Delete Key Id List.

Client UserName

Highlight the feature and press <Enter> to set the client identity (UserName). The length is 0-63 characters.

Client Password

Highlight the feature and press <Enter> to set the client identity (Password). The length is 0-31 characters.

KMS TLS Certificate

This feature displays the Transport Layer Security (TLS) certificate and its size for CA Certificate, Client Certificate, and Client Private Key.

▶ CA Certificate

For the CA certificate, use this feature to enroll factory defaults or load the KMS TLS certificates from the file. The options are **Update**, Delete, and Export.

▶ Client Certificate

For the client certificate, use this feature to enroll factory defaults or load the KMS TLS certificates from the file. The options are **Update**, Delete, and Export.

▶ Client Private Key

For the client private key, use this feature to enroll factory defaults or load the KMS TLS certificates from the file. The options are **Update**, Delete, and Export.

▶ **Intel(R) I210 Gigabit Network Connection**

▶ **Intel(R) I210 Gigabit Network Connection**

▶ **Intel(R) I350 Gigabit Network Connection**

▶ **Intel(R) I350 Gigabit Network Connection**

▶ **Firmware Image Properties**

Option ROM version

Unique NVM/EEPROM ID

NVM Version

▶ **NIC Configuration**

Link Speed

Use this feature to specify the port speed used for the selected boot protocol. The options are **Auto Negotiated**, 10 Mbps Half, 10 Mbps Full, 100 Mbps Half, and 100 Mbps Full.

Wake On LAN

Select Enabled for wake on LAN support, which will allow the system to wake up when an onboard LAN device receives an incoming signal. The options are Disabled and **Enabled**.

Blink LEDs

Use this feature to identify the physical network port by blinking the associated LED. Use the keyboard to select a value.

UEFI Driver

Adapter PBA

Device Name

Chip Type

PCI Device ID

PCI Address

Link Status

MAC Address

Virtual MAC Address

▶ Intel (R) Ethernet Connection E823-L for SFP

▶ Intel (R) Ethernet Connection E823-L for SFP

▶ Firmware Image Properties

Option ROM version

Unique NVM/EEPROM ID

NVM Version

▶ NIC Configuration

Wake On LAN

Select Enabled for wake on LAN support, which will allow the system to wake up when an onboard LAN device receives an incoming signal. The options are Disabled and **Enabled**.

LLDP Agent

Select Enabled to enable the Linked Layer Discovery Protocol Agent. The options are **Disabled** and Enabled.

▶ Device Level Configuration

▶ Port Option Configuration

Port Option

Use this feature to specify the port option of the device. The options are Option 0: 4x10G, **Option 1: 2x25G**, and Option 2: 2x4x0.1G.

Port option outlines

▶ Option 0: 4x10G

▶ Option 1: 2x25G

▶ Option 0: 2x4x0.1G

Blink LEDs

Use this feature to identify the physical network port by blinking the associated LED. Use the keyboard to select a value.

UEFI Driver

Adapter PBA

Device Name

Chip Type

PCI Device ID

PCI Address

Link Status

MAC Address

Virtual MAC Address

▶ **TLS Authentication Configuration**

This submenu allows you to configure Transport Layer Security (TLS) settings.

▶ **Server CA Configuration**

▶ **Enroll Certification**

Enroll Certification Using File

Use this feature to enroll certification from a file.

Certification GUID

Use this feature to input the certification GUID.

Commit Changes and Exit

Use this feature to save all changes and exit TLS settings.

Discard Changes and Exit

Use this feature to discard all changes and exit TLS settings.

▶ **Delete Certification**

Use this feature to delete certification.

▶RAM Disk Configuration

Use this feature to configure RAM disk settings.

Disk Memory Type

Use this feature to specify the type of memory to create a RAM disk. The options are **Boot Service Data** and Reserved.

▶Create raw

Size (Hex):

Use this feature to set the size of the raw RAM disk. The default setting is 1.

Create & Exit

Use this feature to save all changes and exit raw RAM disk settings.

Discard & Exit

Use this feature to save all changes and exit raw RAM disk settings.

▶Create from file

Use this feature to create a RAM disk from a specified file.

Created RAM disk list:

Use this feature to select a RAM disk.

Remove selected RAM disks(s).

Use this feature to delete selected RAM disk(s).

▶ Driver Health

This feature provides the health status for the network drivers and controllers.

▶ Intel(R) PRO/1000 9.3.10 PCIe

Controller 5EE58C98 Child 0

Intel(R) I210 Gigabit Network Connection

▶ Intel(R) PRO/1000 9.3.10 PCIe

Controller 5EE56598 Child 0

Intel(R) I210 Gigabit Network Connection

▶ Intel(R) PRO/1000 9.3.10 PCIe

Controller 5EE54798 Child 0

Intel(R) I210 Gigabit Network Connection

▶ Intel(R) PRO/1000 9.7.06 PCIe

Intel(R) I50 Gigabit Network Connection

Intel(R) I50 Gigabit Network Connection

▶ Intel(R) 100GbE 3.1.18

Intel(R) Ethernet Connection E823-L for SFP

Intel(R) Ethernet Connection E823-L for SFP

▶ Intel(R) 100GbE 3.1.18

Intel(R) Ethernet Connection E823-L for SFP

Intel(R) Ethernet Connection E823-L for SFP

4.4 Event Logs

Use this menu to configure Event Log settings.

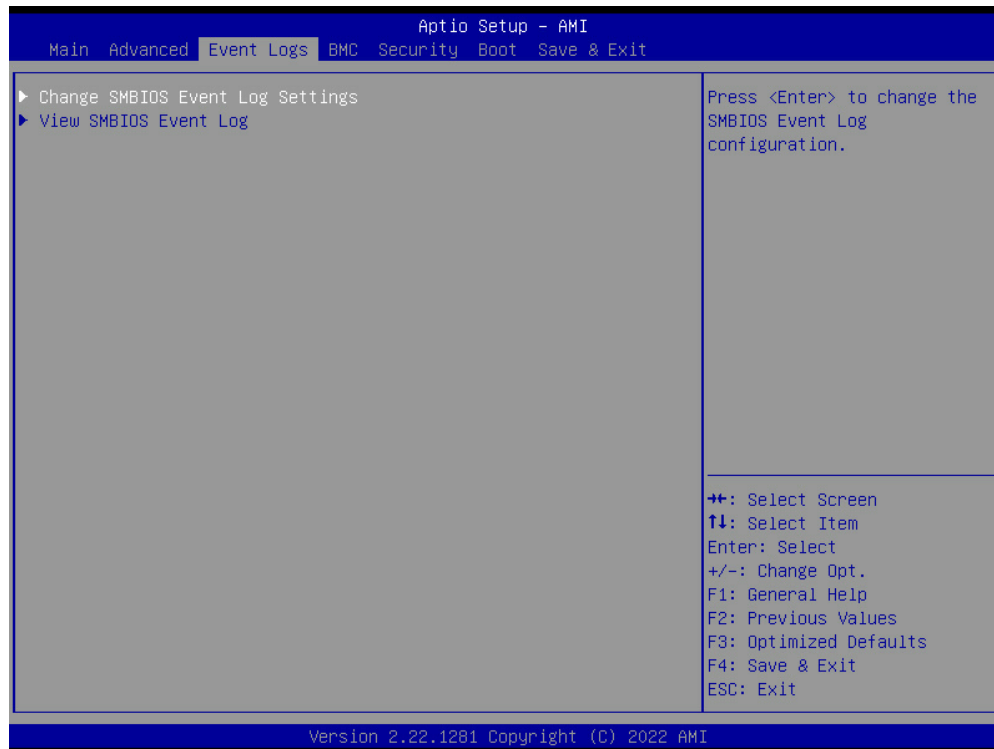

► Change SMBIOS Event Log Settings

Enabling/Disabling Options

SMBIOS Event Log

Change this feature to enable or disable all features of the SMBIOS Event Logging during system boot. The options are Disabled and **Enabled**.

Erasing Settings

Erase Event Log

If No is selected, data stored in the event log will not be erased. Select Yes, Next Reset, data in the event log will be erased upon next system reboot. Select Yes, Every Reset, data in the event log will be erased upon every system reboot. The options are **No**, Yes, Next reset, and Yes, Every reset.

When Log is Full

Select Erase Immediately for all messages to be automatically erased from the event log when the event log memory is full. The options are **Do Nothing** and Erase Immediately.

SMBIOS Event Log Standard Settings

Log System Boot Event

This option toggles the System Boot Event logging to enabled or disabled. The options are **Disabled** and Enabled.

MECI

The Multiple Event Count Increment (MECI) counter counts the number of occurrences that a duplicate event must happen before the MECI counter is incremented. This is a numeric value. The default value is **1**.

METW

The Multiple Event Time Window (METW) defines the number of minutes that must pass between duplicate log events before MECI is incremented. This is in minutes, from 0 to 99. The default value is **60**.

 **Note:** After making changes on a setting, be sure to reboot the system for the changes to take effect.

►View SMBIOS Event Log

Select this submenu and press <Enter> to see the contents of the SMBIOS event log. The following categories will be displayed: Date/Time/Error Codes/Severity.

4.5 BMC

Use this menu to configure Intelligent Platform Management Interface (IPMI) settings.



BMC Firmware Revision

This feature indicates the IPMI firmware revision used in your system.

IPMI STATUS

This feature indicates the status of the IPMI firmware installed in your system.

▶ System Event Log

Enabling/Disabling Options

SEL Components

Select Enabled for all system event logging at boot up. The options are Disabled and **Enabled**.

Erasing Settings

Erase SEL

Select Yes, On next reset to erase all system event logs upon next system reboot. Select No to keep all system event logs after each system reboot. The options are **No**, Yes, On next reset, and Yes, On every reset.

When SEL is Full

This feature allows you to decide what the BIOS should do when the system event log is full. Select Erase Immediately to erase all events in the log when the system event log is full. The options are **Do Nothing** and Erase Immediately.



Note: After making changes on a setting, reboot the system for the changes to take effect.

► BMC Network Configuration

BMC Network Configuration

Update IPMI LAN Configuration

Select Yes for the BIOS to implement all IP/MAC address changes at the next system boot. The options are **No** and Yes.

****If the feature above is set to Yes, Configuration Address Source, VLAN, and IPv6 Support are available for configuration:***

Configure IPv4 Support

IPMI LAN Selection

IPMI Network Link Status

Configuration Address Source

This feature allows you to select the source of the IP address for this computer. If Static is selected, you need to know the IP address of this computer and enter it to the system manually in the field. If DHCP is selected, the BIOS searches for a Dynamic Host Configuration Protocol (DHCP) server in the network that is attached to and request the next available IP address for this computer. The options are **DHCP** and Static.

****If the feature above is set to Static, the following features are available for configuration:***

Station IP Address

This features displays the Station IP address for this computer. The address can be manually entered. This should be in decimal and in dotted quad form (i.e., 192.168.10.253).

Subnet Mask

This feature displays the sub-network that this computer belongs to. The address can be manually entered. The value of each three-digit number separated by dots should not exceed 255.

Station MAC Address**Gateway IP Address**

This feature displays the Gateway IP address for this computer. The address can be manually entered. This should be in decimal and in dotted quad form (i.e., 172.31.0.1).

VLAN

This feature displays the virtual LAN settings. The options are **Disabled** and Enabled.

VLAN ID

This feature is enabled if VLAN is enabled.

Configure IPv6 Support**IPv6 Address Status****IPv6 Support**

Use this feature to enable IPv6 support. The options are **Enabled** and Disabled.

4.6 Security

Use this menu to configure the following security settings for the system.

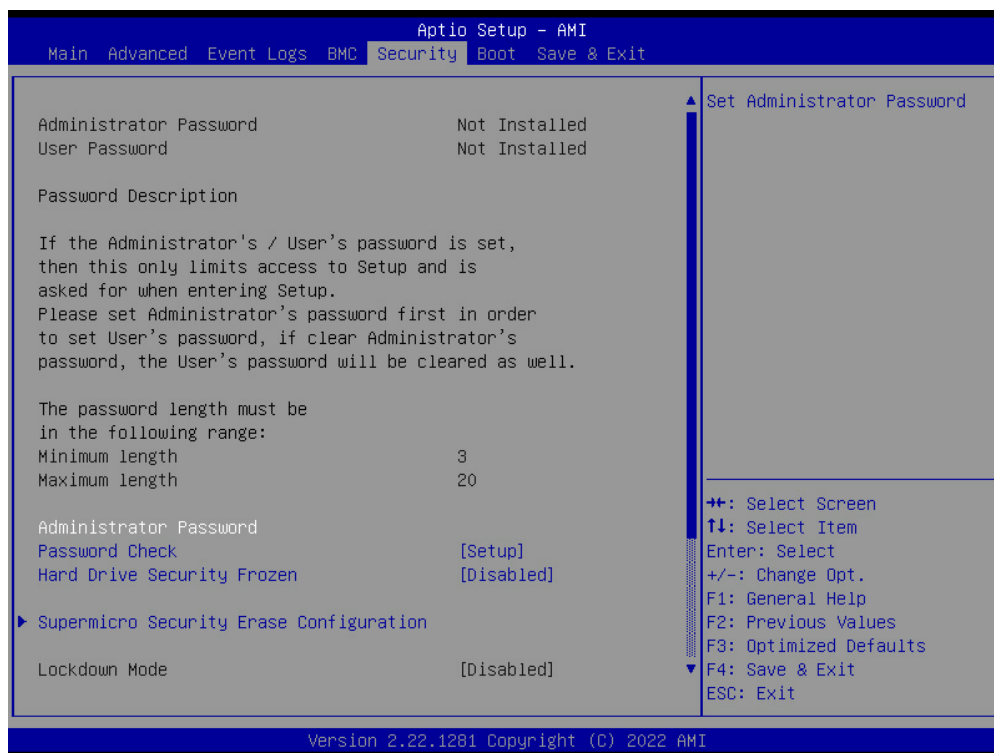

Administrator Password

Press <Enter> to create a new, or change an existing, Administrator password.

Password Check

Select Setup for the system to check for a password at Setup. Select Always for the system to check for a password at bootup or upon entering the BIOS Setup utility. The options are **Setup** and Always.

Hard Drive Security Frozen

Use this feature to enable or disable the BIOS security frozen command for SATA and NVMe devices. The options are Enabled and **Disabled**.

Lockdown mode

Use this feature to switch lockdown mode. The options are **Disabled** and Enabled.

► Supermicro Security Erase Configuration

This section displays following information if a storage device is detected by the system:

- HDD Name
- HDD Serial Number
- Security Mode
- Estimated Time
- HDD User Pwd Status

Security Function

Select Password to set an HDD/SATA password, which will allow you to configure the security settings of the HDD/SATA device. Select Security Erase-Password to enter a SATA user password to erase the password and the contents previously stored in the HDD/SATA device. Select Security Erase-Without Password to use the manufacturer default password "11111111" as the SATA user password and to erase the contents of the HDD/SATA device by using this default password. The options are **Disable**, Set Password, Security ErasePassword, Security Erase-PSID, and Security Erase-Without Password.



Note: Security Erase-PSID is only supported by the M.2 TCG function.

Password

Use this feature to set the SATA user password, which will allow you to configure the Supermicro Security Erase settings by using the SATA user password.

HDD Security Configuration

This section is available for configuration if a storage device is detected by the system.

HDD Password Description:

Use this feature to set, modify, and clear both HDD User Password and HDD Master Password. An installed HDD User Password is required to enable HDD security features. HDD Master Password can be modified only when successfully unlocked in POST. If the "Set HDD Password" option is grayed out, do a power cycle to enable it.

HDD PASSWORD CONFIGURATION:

Set User Password

Use this option to set up the HDD User Password. Power cycle the system after setting the HDD User Password.

▶ Secure Boot

This section displays the contents of the following secure boot features:

- System Mode
- Vendor Keys
- Secure Boot

Secure Boot

Use this feature to enable secure boot. The options are **Disabled** and Enabled.

Secure Boot Mode

Use this item to configure Secure Boot variables without authentication. The options are Standard and **Custom**.

▶ Enter Audit mode

This submenu can only be used if the current System Mode is set to User (refer to Exit Deployed Mode). The PK variable will be erased on transition to Audit Mode.

▶ Key Management

Provision Factory Defaults

Use this feature to install the factory default secure boot keys after the platform reset and while the system is in setup mode. The options are **Disabled** and Enabled.

▶ Restore Factory Keys

Force System to User Mode. Install factory default Secure Boot key databases.

▶ Reset to Setup Mode

This feature deletes all Secure Boot key databases from NVRAM.

▶ Export Secure Boot variables

This feature allows you to copy NVRAM content of Secure boot variables to files in a root folder on a file system device.

▶ Enroll EFI Image

This feature allows the image to run in Secure Boot Mode. Enroll SHA256 Hash Certificate of the image into the Authorized Signature Database.

Device Guard Ready**▶ Remove 'UEFI CA' from DB**

This feature allows you to decide if all secure boot variables should be saved.

▶ Restore DB defaults

Select Yes to restore the DB defaults.

Secure Boot Variable**▶ Platform Key (PK)****Update**

Select Yes to load the new Platform Keys (PK) from the manufacturer's defaults. Select No to load the Platform Keys from a file.

▶ Key Exchange Key**Update**

Select Yes to load the KEK from the manufacturer's defaults. Select No to load the Key Exchange Keys from a file.

Append

Select Yes to add the KEK from the manufacturer's defaults list to the existing KEK. Select No to load the KEK from a file.

▶ Authorized Signatures**Update**

Select Yes to load the DB from the manufacturer's defaults. Select No to load the DB from a file.

Append

Select Yes to add the DB from the manufacturer's defaults list to the existing DB. Select No to load the DB from a file.

►Forbidden Signatures

Update

Select Yes to load the DBX from the manufacturer's defaults. Select No to load the DBX from a file.

Append

Select Yes to add the DBX from the manufacturer's defaults list to the existing DBX. Select No to load the DBX from a file.

►Authorized TimeStamps

Update

Select Yes to load the DBT from the manufacturer's defaults. Select No to load the DBT from a file.

Append

Select Yes to add the DBT from the manufacturer's defaults list to the existing DBT. Select No to load the DBT from a file.

►OsRecovery Signature

Update

Select Yes to load the DBR from the manufacturer's defaults. Select No to load the DBR from a file.

Append

Select Yes to add the DBR from the manufacturer's defaults list to the existing DBR. Select No to load the DBR from a file.

4.7 Boot

Use this menu to configure Boot settings.

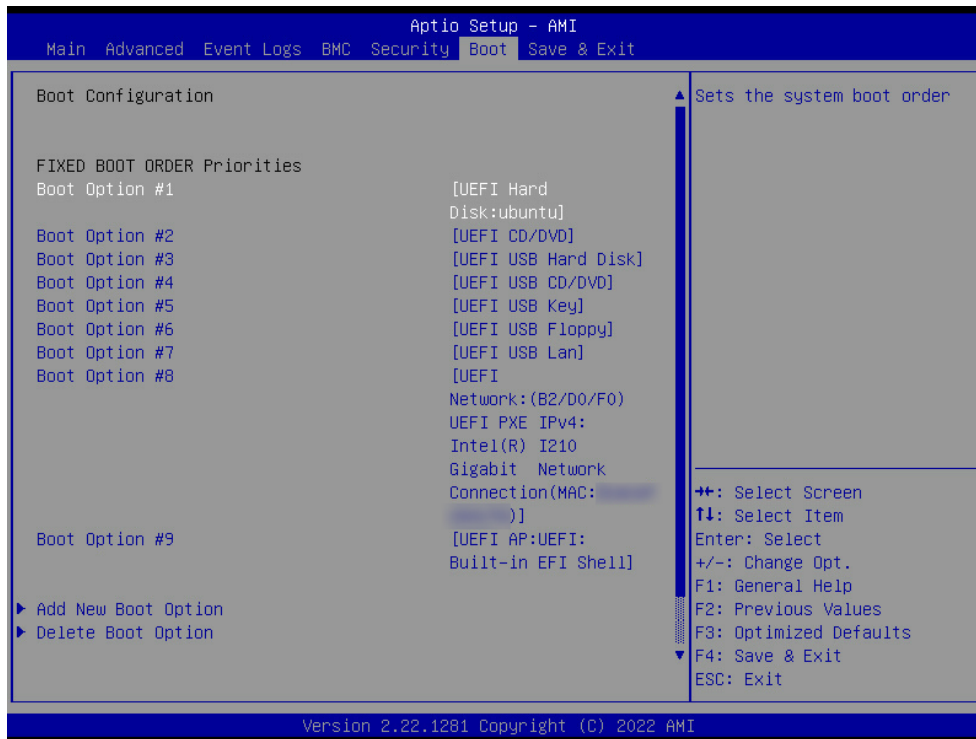

Fixed Boot Order Priorities

This option prioritizes the order of bootable devices that the system boots from. Press <Enter> on each entry from top to bottom to select devices.

- Boot Option #1
- Boot Option #2
- Boot Option #3
- Boot Option #4
- Boot Option #5
- Boot Option #6
- Boot Option #7
- Boot Option #8
- Boot Option #9

► Add New Boot Option

This feature allows you to add a new boot option to the boot priority features for your system.

Add Boot Option

Use this feature to specify the name for the new boot option.

Path for Boot Option

Use this feature to enter the path for the new boot option in the format fsx:\path\filename.efi.

Boot Option File Path

Use this feature to specify the file path for the new boot option.

Create

Use this feature to set the name and the file path of the new boot option.

► Delete Boot Option

This feature allows you to select a boot device to delete from the boot priority list.

Delete Boot Option

Use this item to remove an EFI boot option from the boot priority list.

► UEFI NETWORK Drive BBS Priorities

This feature sets the system boot order of detected devices.

- Boot Option #1
- Boot Option #2
- Boot Option #3
- Boot Option #4

► UEFI Application Boot Priorities

This feature sets the system boot order of detected devices.

- Boot Option #1

4.8 Save & Exit

Use this menu to save settings and exit from the BIOS.

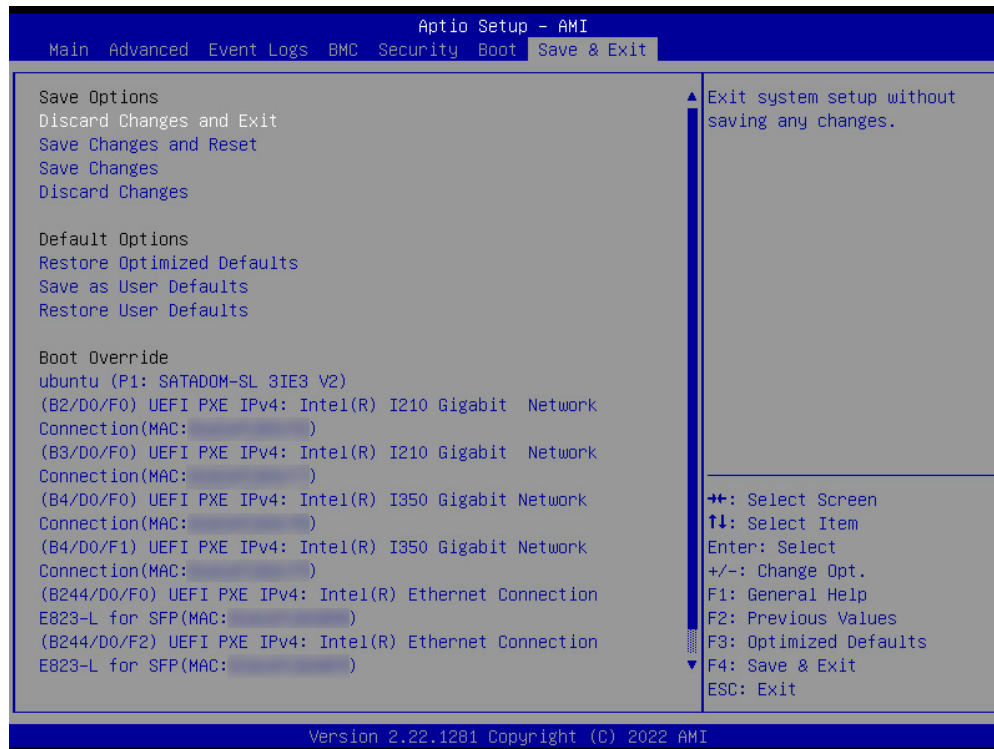

Save Options

Discard Changes and Exit

Select this option to quit the BIOS Setup without making any permanent changes to the system configuration, and reboot the computer. Select Discard Changes and Exit from the Save & Exit menu and press <Enter>.

Save Changes and Reset

After completing the system configuration changes, select this option to save the changes you have made. This will not reset (reboot) the system.

Save Changes

When you have completed the system configuration changes, select this option to leave the BIOS setup utility and reboot the computer for the new system configuration parameters to take effect. Select Save Changes from the Save & Exit menu and press <Enter>.

Discard Changes

Select this option and press <Enter> to discard all the changes and return to the AMI BIOS utility program.

Default Options

Restore Optimized Defaults

To set this feature, select Restore Defaults from the Save & Exit menu and press <Enter>. These are factory settings designed for maximum system stability, but not for maximum performance.

Save As User Defaults

To set this feature, select Save as User Defaults from the Save & Exit menu and press <Enter>. This enables you to save any changes to the BIOS setup for future use.

Restore User Defaults

To set this feature, select Restore User Defaults from the Save & Exit menu and press <Enter>. Use this feature to retrieve user-defined settings that were saved previously.

Boot Override

Listed in this section are other boot options for the system (i.e., Built-in EFI shell). The options may vary on each system. Select an option, press <Enter>, and your system will boot to the selected boot option.

**(B2/D0/F0) UEFI PXE IPv4: Intel(R) I210 Gigabit Network Connection
(MAC:XXXXXXXXXXXX)**

**(B3/D0/F0) UEFI PXE: IPv4: Intel(R) I210 Gigabit Network Connection
(MAC:XXXXXXXXXXXX)**

**(B4/D0/F0) UEFI PXE: IPv4: Intel(R) I350 Gigabit Network Connection
(MAC:XXXXXXXXXXXX)**

**(B4/D0/F1) UEFI PXE: IPv4: Intel(R) I350 Gigabit Network Connection
(MAC:XXXXXXXXXXXX)**

**(B244/D0/F0) UEFI PXE: IPv4: Intel(R) I350 Ethernet Connection E823-L for SFP
(MAC:XXXXXXXXXXXX)**

**(B244/D0/F2) UEFI PXE: IPv4: Intel(R) I350 Ethernet Connection E823-L for SFP
(MAC:XXXXXXXXXXXX)**

UEFI: Built-in EFI Shell

Launch EFI Shell from filesystem device

Appendix A

BIOS Codes

A.1 BIOS Error POST (Beep) Codes

During the Power-On Self-Test (POST) routines, which are performed each time the system is powered on, errors may occur.

Non-fatal errors are those which, in most cases, allow the system to continue the boot-up process. The error messages normally appear on the screen.

Fatal errors are those which will not allow the system to continue the boot-up procedure. If a fatal error occurs, you should consult with your system manufacturer for possible repairs.

These fatal errors are usually communicated through a series of audible beeps. The table shown below lists some common errors and their corresponding beep codes encountered by users.

BIOS Beep (POST) Codes		
Beep Code	Error Message	Description
1 beep	Refresh	Circuits have been reset (Ready to power up)
5 short, 1 long	Memory error	No memory detected in system
5 long, 2 short	Display memory read/write error	Video adapter missing or with faulty memory
1 long continuous	System OH	System overheat condition

A.2 Additional BIOS POST Codes

The AMI BIOS supplies additional checkpoint codes, which are documented online at <http://www.supermicro.com/support/manuals/> ("AMI BIOS POST Codes User's Guide").

For information on AMI updates, refer to <http://www.ami.com/products/>.

Appendix B

Software

After the hardware has been installed, you can install the Operating System (OS), configure RAID settings and install the drivers.

B.1 Microsoft Windows OS Installation

If you will be using RAID, you must configure RAID settings before installing the Windows OS and the RAID driver. Refer to the RAID Configuration User Guides posted on our website at www.supermicro.com/support/manuals.

Installing the OS

1. Create a method to access the MS Windows installation ISO file. That can be a USB flash or media drive.
2. Retrieve the proper RST/RSTe driver. Go to the Supermicro web page for your motherboard and click on "Download the Latest Drivers and Utilities", select the proper driver, and copy it to a USB flash drive.
3. Boot from a bootable device with Windows OS installation. You can see a bootable device list by pressing <F11> during the system startup.

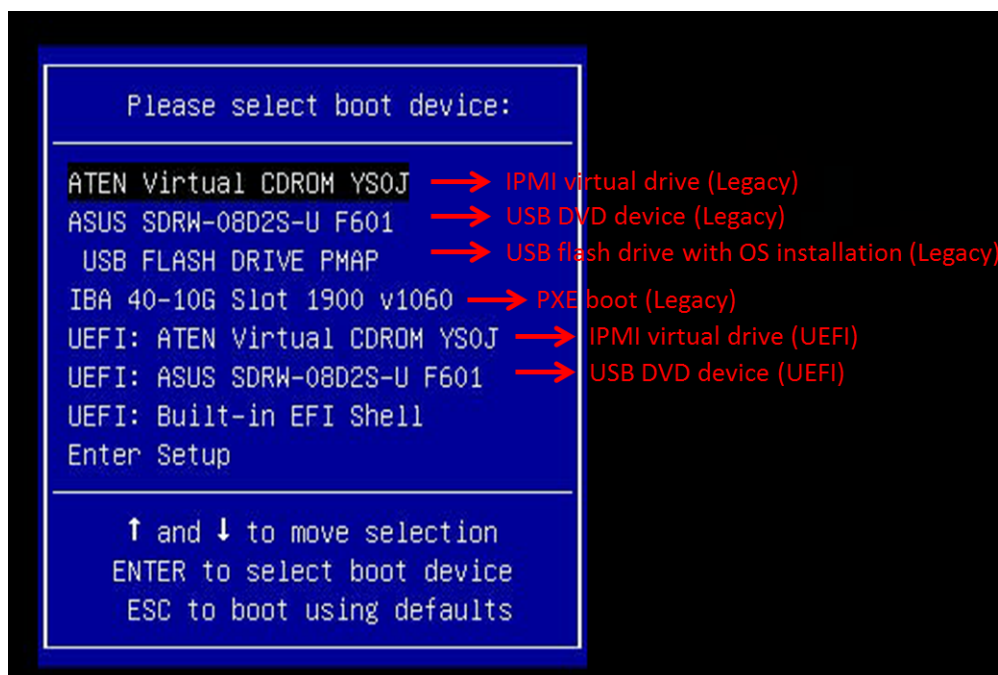

Figure B-1. Select Boot Device

4. During Windows Setup, continue to the dialog where you select the drives on which to install Windows. If the disk you want to use is not listed, click on “Load driver” link at the bottom left corner.

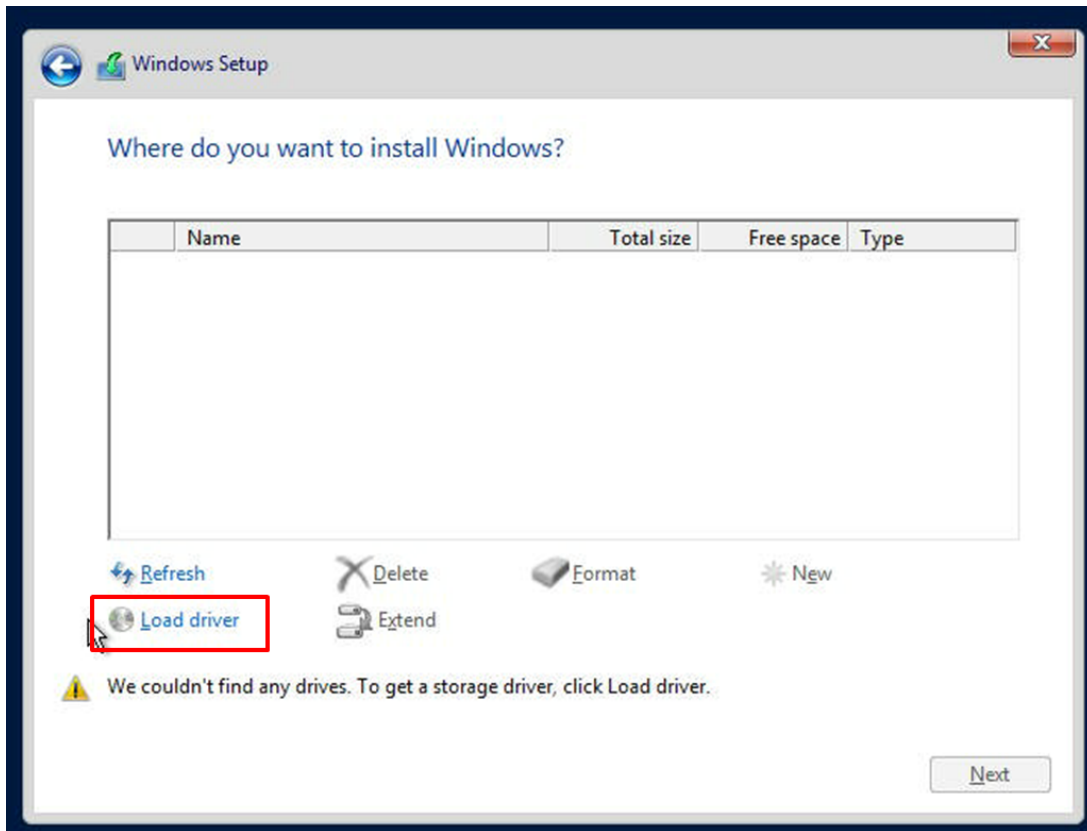

Figure B-2. Load Driver Link

To load the driver, browse the USB flash drive for the proper driver files.

- For RAID, choose the SATA/sSATA RAID driver indicated then choose the storage drive on which you want to install it.
 - For non-RAID, choose the SATA/sSATA AHCI driver indicated then choose the storage drive on which you want to install it.
5. Once all devices are specified, continue with the installation.
 6. After the Windows OS installation has completed, the system will automatically reboot multiple times.

B.2 Driver Installation

The Supermicro website contains drivers and utilities for your system at <https://www.supermicro.com/wdl/driver/>. Some of these must be installed, such as the chipset driver.

After accessing the website, go into the CDR_Images (in the parent directory of the above link) and locate the ISO file for your motherboard. Download this file to a USB flash or media drive. You may also use a utility to extract the ISO file if preferred.

Another option is to go to the Supermicro website at <http://www.supermicro.com/products/>. Find the product page for your motherboard and download the latest drivers and utilities.

Insert the flash drive or disk and the screenshot shown below should appear.

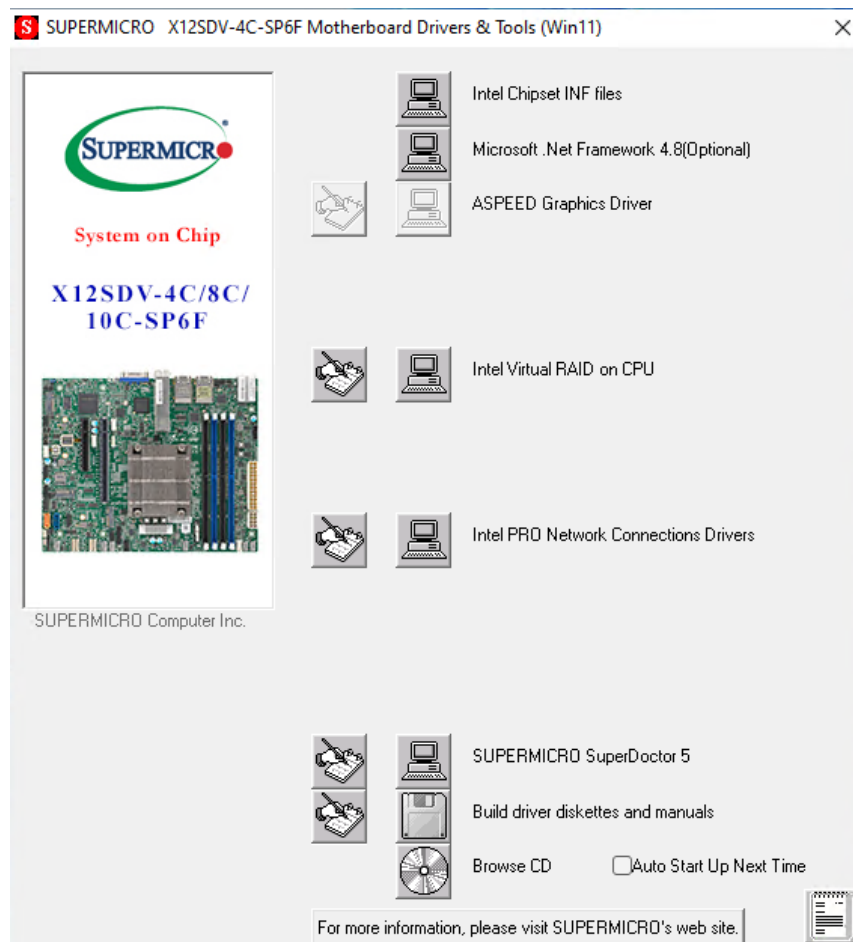



Figure B-3. Driver & Tool Installation Screen

 **Note:** Click the icons showing a hand writing on paper to view the readme files for each item. Click the computer icons to the right of these items to install each item from top to bottom one at a time. **After installing each item, you must reboot the system before moving on to the next item on the list.** The bottom icon with a CD on it allows you to view the entire contents.

B.3 SuperDoctor® 5

The Supermicro SuperDoctor 5 is a program that functions in a command-line or web-based interface for Windows and Linux operating systems. The program monitors such system health information as CPU temperature, system voltages, system power consumption, fan speed, and provides alerts via email or Simple Network Management Protocol (SNMP).

SuperDoctor 5 comes in local and remote management versions and can be used with Nagios to maximize your system monitoring needs. With SuperDoctor 5 Management Server (SSM Server), you can remotely control power on/off and reset chassis intrusion for multiple systems with SuperDoctor 5. SuperDoctor 5 Management Server monitors HTTP, FTP, and SMTP services to optimize the efficiency of your operation.

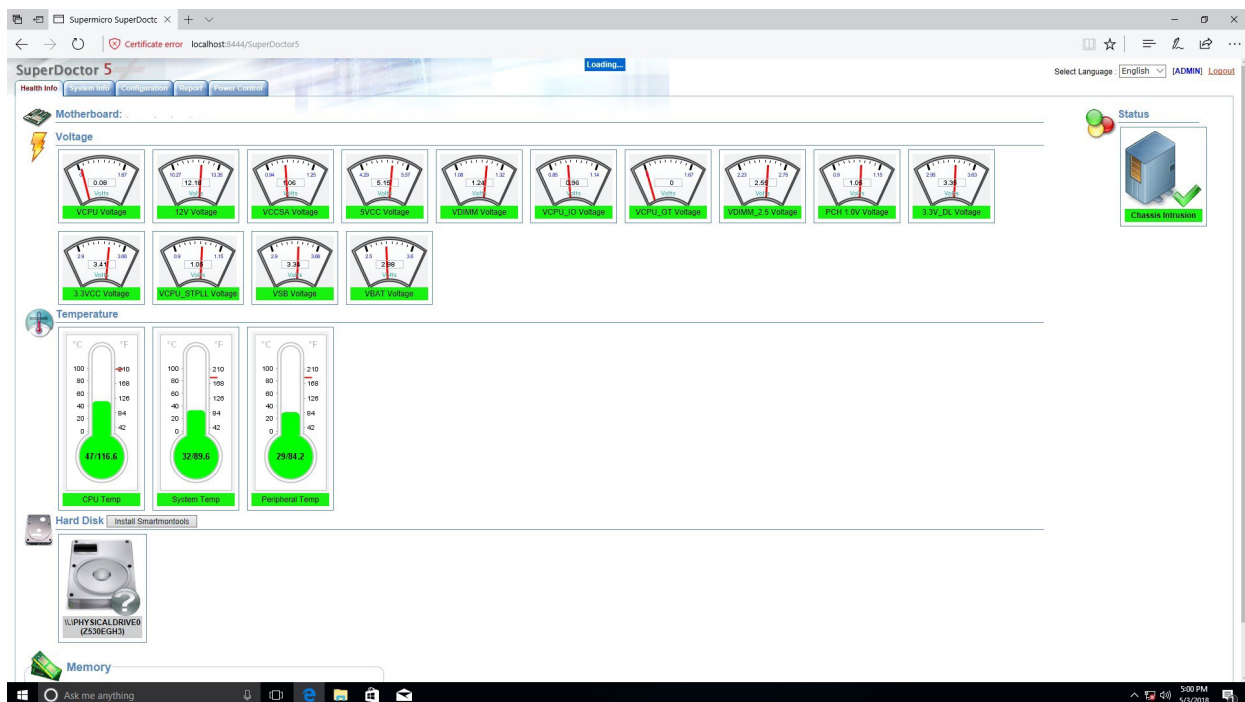

Figure B-4. SuperDoctor 5 Interface Display Screen (Health Information)



Note: The default User Name and Password for SuperDoctor 5 is ADMIN / ADMIN.

Appendix C

Standardized Warning Statements

The following statements are industry standard warnings, provided to warn the user of situations which have the potential for bodily injury. Should you have questions or experience difficulty, contact Supermicro's Technical Support department for assistance. Only certified technicians should attempt to install or configure components.

Read this section in its entirety before installing or configuring components.

These warnings may also be found on our website at http://www.supermicro.com/about/policies/safety_information.cfm.

Battery Handling



Warning! There is the danger of explosion if the battery is replaced incorrectly. Replace the battery only with the same or equivalent type recommended by the manufacturer. Dispose of used batteries according to the manufacturer's instructions

電池の取り扱い

電池交換が正しく行われなかった場合、破裂の危険性があります。交換する電池はメーカーが推奨する型、または同等のものを使用下さい。使用済電池は製造元の指示に従って処分して下さい。

警告

電池更換不當會有爆炸危險。請只使用同類電池或製造商推薦的功能相當的電池更換原有電池。請按製造商的說明處理廢舊電池。

警告

電池更換不當會有爆炸危險。請使用製造商建議之相同或功能相當的電池更換原有電池。請按照製造商的說明指示處理廢棄舊電池。

Warnung

Bei Einsetzen einer falschen Batterie besteht Explosionsgefahr. Ersetzen Sie die Batterie nur durch den gleichen oder vom Hersteller empfohlenen Batterietyp. Entsorgen Sie die benutzten Batterien nach den Anweisungen des Herstellers.

Attention

Danger d'explosion si la pile n'est pas remplacée correctement. Ne la remplacer que par une pile de type semblable ou équivalent, recommandée par le fabricant. Jeter les piles usagées conformément aux instructions du fabricant.

¡Advertencia!

Existe peligro de explosión si la batería se reemplaza de manera incorrecta. Reemplazar la batería exclusivamente con el mismo tipo o el equivalente recomendado por el fabricante. Desechar las baterías gastadas según las instrucciones del fabricante.

אזהרה!

קיימת סכנת פיצוץ של הסוללה במידה והוחלפה בדרך לא תקינה. יש להחליף את הסוללה בסוג התואם מחברת יצרן מומלצת. סילוק הסוללות המשומשות יש לבצע לפי הוראות היצרן.

هناك خطر من انفجار في حالة اسبدال البطارية بطريقة غير صحيحة فعلياً
اسبدال البطارية
فقط بنفس النوع أو ما يعادلها مما أوصت به الشركة المصنعة
جخلص من البطاريات المسحمة وفقاً لتعليمات الشركة الصانعة

경고!

배터리가 올바르게 교체되지 않으면 폭발의 위험이 있습니다. 기존 배터리와 동일하거나 제조사에서 권장하는 동등한 종류의 배터리로만 교체해야 합니다. 제조사의 안내에 따라 사용된 배터리를 처리하여 주십시오.

Waarschuwing

Er is ontploffingsgevaar indien de batterij verkeerd vervangen wordt. Vervang de batterij slechts met hetzelfde of een equivalent type die door de fabrikant aanbevolen wordt. Gebruikte batterijen dienen overeenkomstig fabrieksvoorschriften afgevoerd te worden.

Product Disposal



Warning! Ultimate disposal of this product should be handled according to all national laws and regulations.

製品の廃棄

この製品を廃棄処分する場合、国の関係する全ての法律・条例に従い処理する必要があります。

警告

本产品的废弃处理应根据所有国家的法律和规章进行。

警告

本產品的廢棄處理應根據所有國家的法律和規章進行。

Warnung

Die Entsorgung dieses Produkts sollte gemäß allen Bestimmungen und Gesetzen des Landes erfolgen.

¡Advertencia!

Al deshacerse por completo de este producto debe seguir todas las leyes y reglamentos nacionales.

Attention

La mise au rebut ou le recyclage de ce produit sont généralement soumis à des lois et/ou directives de respect de l'environnement. Renseignez-vous auprès de l'organisme compétent.

סילוק המוצר

אזהרה!

סילוק סופי של מוצר זה חייב להיות בהתאם להנחיות וחוקי המדינה.

عند التخلص النهائي من هذا المنتج ينبغي التعامل معه وفقا لجميع القوانين واللوائح الوطنية

경고!

이 제품은 해당 국가의 관련 법규 및 규정에 따라 폐기되어야 합니다.

Waarschuwing

De uiteindelijke verwijdering van dit product dient te geschieden in overeenstemming met alle nationale wetten en reglementen.

Appendix D

UEFI BIOS Recovery

Warning: Do not upgrade the BIOS unless your system has a BIOS-related issue. Flashing the wrong BIOS can cause irreparable damage to the system. In no event shall Supermicro be liable for direct, indirect, special, incidental, or consequential damages arising from a BIOS update. If you need to update the BIOS, do not shut down or reset the system while the BIOS is updating to avoid possible boot failure.

D.1 Overview

The Unified Extensible Firmware Interface (UEFI) provides a software-based interface between the operating system and the platform firmware in the pre-boot environment. The UEFI specification supports an architecture-independent mechanism that will allow the UEFI OS loader stored in an add-on card to boot the system. The UEFI offers clean, hands-off management to a computer during system boot.

D.2 Recovering the UEFI BIOS Image

A UEFI BIOS flash chip consists of a recovery BIOS block and a main BIOS block (a main BIOS image). The recovery block contains critical BIOS codes, including memory detection and recovery codes for you to flash a healthy BIOS image if the original main BIOS image is corrupted. When the system power is first turned on, the boot block codes execute first. Once this process is completed, the main BIOS code will continue with system initialization and the remaining Power-On Self-Test (POST) routines.

 **Note 1:** Follow the BIOS recovery instructions below for BIOS recovery when the main BIOS block crashes.

 **Note 2:** When the BIOS recovery block crashes, you will need to follow the procedures to make a Returned Merchandise Authorization (RMA) request. For an RMA request, see section 3.5 for more information. Also, you may use the Supermicro Update Manager (SUM) Out-of-Band (OOB) (https://www.supermicro.com.tw/products/nfo/SMS_SUM.cfm) to reflash the BIOS.

D.3 Recovering the BIOS Block with a USB Device

This feature allows you to recover the main BIOS image using a USB-attached device without additional utilities used. A USB flash or media device can be used for this purpose. However, a USB Hard Disk drive cannot be used for BIOS recovery at this time.

The file system supported by the recovery block is FAT (including FAT12, FAT16, and FAT32), which is installed on a bootable or non-bootable USB-attached device. However, the BIOS might need several minutes to locate the SUPER.ROM file if the media size becomes too large due to the huge volumes of folders and files stored in the device.

To perform UEFI BIOS recovery using a USB-attached device, follow the instructions below:

1. Using a different machine, copy the "Super.ROM" binary image file into the disc Root "\\" directory of a USB flash or media device.

 **Note 1:** If you cannot locate the "Super.ROM" file in your driver disk, visit our website at www.supermicro.com to download the BIOS package. Extract the BIOS binary image into a USB flash device and rename it "Super.ROM" for the BIOS recovery use.

 **Note 2:** Before recovering the main BIOS image, confirm that the "Super.ROM" binary image file you download is the same version or a close version meant for your motherboard.

2. Insert the USB device that contains the new BIOS image ("Super.ROM") into your USB port and reset the system until the following screen appears:



- After locating the new BIOS binary image, the system will enter the BIOS Recovery menu as shown below:

 **Note:** At this point, you may decide if you want to start the BIOS recovery. If you decide to proceed with BIOS recovery, follow the procedures below.

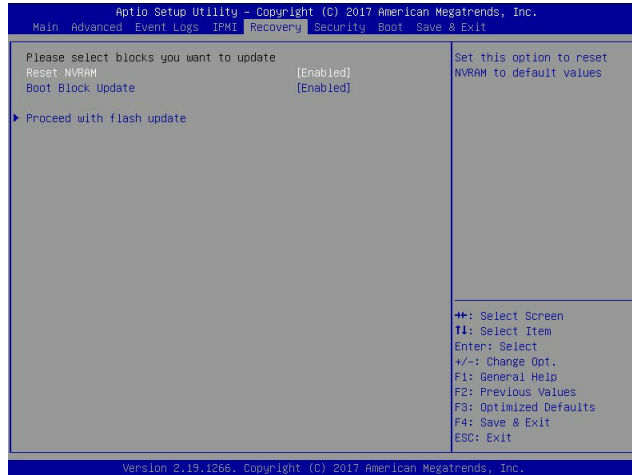

- When the screen as shown above displays, use the arrow keys to select the item "Proceed with flash update" and press the <Enter> key. You will see the BIOS recovery progress as shown in the screen below:

 **Note:** Do not interrupt the BIOS flashing process until it has completed.

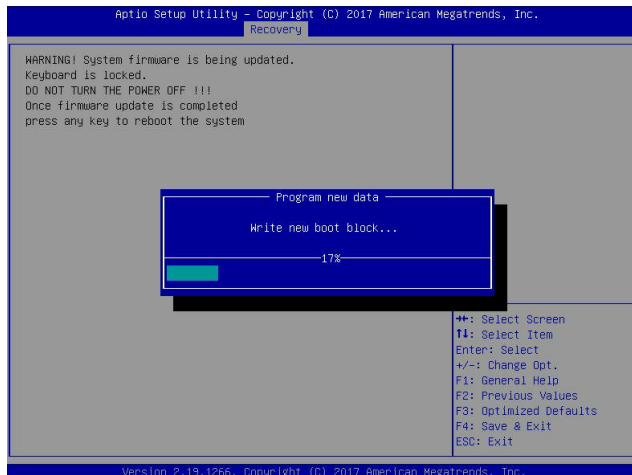

5. After the BIOS recovery process is completed, press any key to reboot the system.

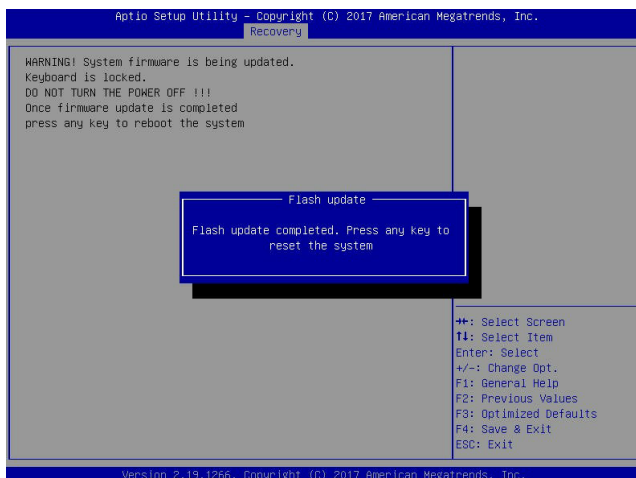

6. Using a different system, extract the BIOS package into a USB flash drive.
7. Press during system boot to enter the BIOS Setup utility. From the top of the tool bar, select Boot to enter the submenu. From the submenu list, select Boot Option #1 as shown below. Then, set Boot Option #1 to [UEFI AP:UEFI: Built-in EFI Shell]. Press <F4> to save the settings and exit the BIOS Setup utility.

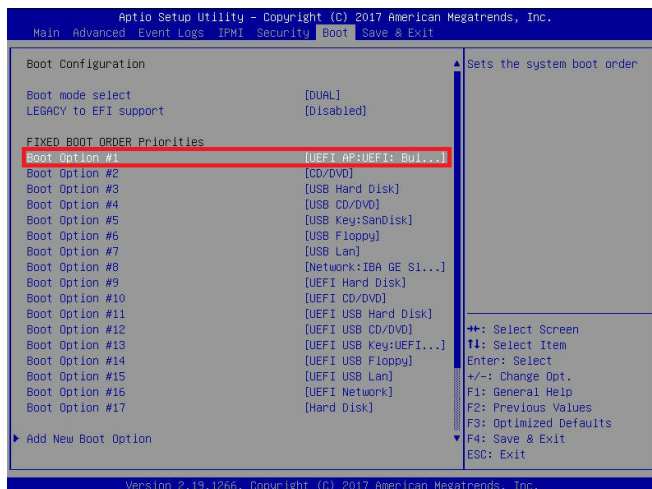

- When the UEFI Shell prompt appears, type `fs#` to change the device directory path. Go to the directory that contains the BIOS package you extracted earlier from Step 6. Enter `flash.nsh BIOSname.###` at the prompt to start the BIOS update process.

```

UEFI Interactive Shell v2.1
EDK II
UEFI v2.50 (American Megatrends, 0x0005000C)
Mapping table
  FS0: Alias(s):HD(0)0B:BLK1:
      PciRoot(0x0)/Pci(0x14,0x0)/USB(0x11,0x0)/HD(1,MBR,0x37901072,0x800,0x1
DR9592)
  BLK0: Alias(s):
      PciRoot(0x0)/Pci(0x14,0x0)/USB(0x11,0x0)
Press F8P in 1 seconds to skip startup.nsh or any other key to continue.
Shell> fs0:
FS0:\> cd AFUDOS
FS0:\AFUDOS> cd SNIPME2_03162017
FS0:\AFUDOS\SNIPME2_03162017> flash.nsh X12DPU7_314
    
```

 **Note:** Do not interrupt this process until the BIOS flashing is complete.

```

Done.
[ Access Cmos Port Ex ]
<Read>
Index 0x51: 0x10

Done.
*****
* Program BIOS and ME (including FDT) regions...
*****
| AMT Firmware Update Utility v5.09.01.1917
| Copyright (C)2017 American Megatrends Inc. All Rights Reserved.
|-----|
CPUID = 50652

Reading flash ..... done
- ME Data Size checking - ok
- FFS checksums ..... ok
- Check ROMLayout ..... Ok
Erasing Boot Block ..... done
Updating Boot Block ..... done
Verifying Boot Block ..... done
_Erasing Main Block ..... 0x00132000 (0x)
    
```

```

Verifying NCB Block ..... done
- Update success for FDR
- Update success for IE
- Successful Update Recovery Loader to OPRx11
- Successful Update MFSB11
- Successful Update FTPR11
- Successful Update MFS, IMB1 and IMB211
- Successful Update FLOS and UTRx11
- ME Entire Image update success !!

WARNING : System must power-off to have the changes take effect!
Moving FS0:\AFUDOS\SNIPME2_03162017\Fdtx64.efi -> FS0:\AFUDOS\SNIPME2_03162017\F
dt.smc
- [ok]
Moving FS0:\AFUDOS\SNIPME2_03162017\afuef1x64.efi -> FS0:\AFUDOS\SNIPME2_0316201
7\afuef1.smc
- [ok]
*****
* Please ignore this "Shell: Cannot read from file - Device Error"
* warning message due to it does not impact flashing process.
*****
Deleting "afuef1.smc"
Delete successful.
FS0:\>
    
```

- The screen above indicates that the BIOS update process is complete. When you see the screen above, unplug the AC power cable from the power supply, clear CMOS, and plug the AC power cable in the power supply again to power on the system.
- Press `` to enter the BIOS Setup utility.
- Press `<F3>` to load the default settings.
- After loading the default settings, press `<F4>` to save the settings and exit the BIOS Setup utility.