



X14DBM-SP

USER'S MANUAL

Revision 1.1a (MNL-2663)

The information in this User's Manual has been carefully reviewed and is believed to be accurate. The vendor assumes no responsibility for any inaccuracies that may be contained in this document, and makes no commitment to update or to keep current the information in this manual, or to notify any person or organization of the updates. Note: For the most up-to-date version of this manual, see our website at <https://www.supermicro.com>.

Super Micro Computer, Inc. ("Supermicro") reserves the right to make changes to the product described in this manual at any time and without notice. This product, including software and documentation, is the property of Supermicro and/or its licensors, and is supplied only under a license. Any use or reproduction of this product is not allowed, except as expressly permitted by the terms of said license.

IN NO EVENT WILL Super Micro Computer, Inc. BE LIABLE FOR DIRECT, INDIRECT, SPECIAL, INCIDENTAL, SPECULATIVE OR CONSEQUENTIAL DAMAGES ARISING FROM THE USE OR INABILITY TO USE THIS PRODUCT OR DOCUMENTATION, EVEN IF ADVISED OF THE POSSIBILITY OF SUCH DAMAGES. IN PARTICULAR, SUPER MICRO COMPUTER, INC. SHALL NOT HAVE LIABILITY FOR ANY HARDWARE, SOFTWARE, OR DATA STORED OR USED WITH THE PRODUCT, INCLUDING THE COSTS OF REPAIRING, REPLACING, INTEGRATING, INSTALLING OR RECOVERING SUCH HARDWARE, SOFTWARE, OR DATA.

Any disputes arising between manufacturer and customer shall be governed by the laws of Santa Clara County in the State of California, USA. The State of California, County of Santa Clara shall be the exclusive venue for the resolution of any such disputes. Supermicro's total liability for all claims will not exceed the price paid for the hardware product.

FCC Statement: This equipment has been tested and found to comply with the limits for a Class A or Class B digital device pursuant to Part 15 of the FCC Rules. These limits are designed to provide reasonable protection against harmful interference when the equipment is operated in industrial environment for Class A device or in residential environment for Class B device. This equipment generates, uses, and can radiate radio frequency energy and, if not installed and used in accordance with the manufacturer's instruction manual, may cause harmful interference with radio communications. Operation of this equipment in a residential area is likely to cause harmful interference, in which case you will be required to correct the interference at your own expense.

California Best Management Practices Regulations for Perchlorate Materials: This Perchlorate warning applies only to products containing CR (Manganese Dioxide) Lithium coin cells. "Perchlorate Material-special handling may apply. See <https://www.dtsc.ca.gov/hazardouswaste/perchlorate>".



WARNING: This product can expose you to chemicals including lead, known to the State of California to cause cancer and birth defects or other reproductive harm. For more information, go to <https://www.P65Warnings.ca.gov>.



AVERTISSEMENT : Ce produit peut vous exposer à des agents chimiques, y compris le plomb, identifié par l'État de Californie comme pouvant causer le cancer, des malformations congénitales ou d'autres troubles de la reproduction. Pour de plus amples informations, prière de consulter <https://www.P65Warnings.ca.gov>.

The products sold by Supermicro are not intended for and will not be used in life support systems, medical equipment, nuclear facilities or systems, aircraft, aircraft devices, aircraft/emergency communication devices or other critical systems whose failure to perform be reasonably expected to result in significant injury or loss of life or catastrophic property damage. Accordingly, Supermicro disclaims any and all liability, and should buyer use or sell such products for use in such ultra-hazardous applications, it does so entirely at its own risk. Furthermore, buyer agrees to fully indemnify, defend and hold Supermicro harmless for and against any and all claims, demands, actions, litigation, and proceedings of any kind arising out of or related to such ultra-hazardous use or sale.

Manual Revision 1.1a

Release Date: July 31, 2025

Unless you request and receive written permission from Super Micro Computer, Inc., you may not copy any part of this document. Information in this document is subject to change without notice. Other products and companies referred to herein are trademarks or registered trademarks of their respective companies or mark holders.

Copyright © 2025 by Super Micro Computer, Inc.
All rights reserved.

Published in the United States of America

Preface

About This Manual

This manual is written for professional system integrators and PC technicians. It provides information for the installation and use of the X14DBM-SP motherboard. Installation and maintenance should be performed by certified service technicians only.

Notes

For your system to work properly, follow the links below to download all necessary drivers/utilities and the user's manual for your motherboard.

- Supermicro product manuals: <https://www.supermicro.com/support/manuals>
- Product drivers and utilities: <https://www.supermicro.com/wdl>
- Product safety info: https://www.supermicro.com/about/policies/safety_information.cfm
- A secure data deletion tool designed to fully erase all data from storage devices can be found on our website:
https://www.supermicro.com/about/policies/disclaimer.cfm?url=/wdl/utility/Lot9_Secure_Data_Deletion_Utility
- Frequently Asked Questions: <https://www.supermicro.com/FAQ/index.php>
- If you still have questions after referring to our FAQs, contact our support team. Region-specific Technical Support email addresses can be found at: "[Contacting Supermicro](#)" on page 11
- If you have any feedback on Supermicro product manuals, contact our writing team at: Techwriterteam@supermicro.com

This manual may be periodically updated without notice. Check the Supermicro website for possible updates to the manual revision level.

Conventions Used in the Manual

Special attention should be given to the following symbols for proper installation and to prevent damage done to the components or injury to yourself.



Warning! Indicates important information given to prevent equipment/property damage or personal injury.



Warning! Indicates high voltage may be encountered while performing a procedure.

Important: Important information given to ensure proper motherboard installation or to relay safety precautions.

Note: Additional information given to differentiate various models or to provide information for proper motherboard setup.

Contents

Contacting Supermicro	11
Chapter 1: Introduction	12
1.1 Quick Reference	13
Motherboard Layout	13
Quick Reference Table	14
Memory Slots	17
Motherboard Features	18
Motherboard Block Diagram	22
1.2 Platform Overview	23
Flexible and Scalable Processor Architectural Design	23
New Software Capability and Performance Optimization	23
1.3 Special Features	24
Recovery from AC Power Loss	24
1.4 System Health Monitoring	25
Onboard Voltage Monitors	25
Fan Status Monitor with Firmware Control	25
Environmental Temperature Control	25
1.5 ACPI Features	26
1.6 Serial Port	27
Chapter 2: Component Installation	28
2.1 Static-Sensitive Devices	30
Precautions	30
Unpacking	30
2.2 Motherboard Installation	31
Mounting Holes/T-pin Cutouts/Heatsink Standoffs	31
Installing the Motherboard	34
2.3 Processor and Heatsink Installation	36
LGA 4710 Socket E2 Processors	36
Processor Top View	36
Overview of the Processor Socket	37
Overview of the Processor Carrier	37

Processor Carriers	38
Overview of the Processor Heatsink Module	39
Installing the Processor	42
Assembling the Processor Heatsink Module	44
Preparing the Processor Socket for Installation	51
Preparing to Install the PHM into the Processor Socket	52
Installing the Processor Heatsink Module	55
Removing the Processor Heatsink Module	63
2.4 Memory Support and Installation	73
Memory Support	73
Intel Xeon 6700-Series Processors with E-Cores	73
Intel Xeon 6700-Series Processors with P-Cores	76
General Guidelines for Optimizing Memory Performance	81
DIMM Installation	82
DIMM Removal	84
2.5 Battery Removal and Installation	85
Battery Removal	85
Proper Battery Disposal	85
Battery Installation	85
2.6 Connections, Jumpers, and LEDs	86
Power Supply and Power Connections	86
Power Supply	86
6-Pin Riser Card Power Connectors (JPWR1/JPWR2)	87
8-Pin/16-Pin Backplane/GPU Power Connectors (JPMW1–JPMW4 and JPMW5–JPMW7)	87
Main Server Power Connectors (PSU1/PSU2)	88
Headers and Connections	88
6-pin BMC External I ² C Header	88
BMC LAN/USB/VGA Connector	89
Chassis Intrusion	89
Expansion Slots	89
Fan Headers	89
Liquid Leak Check Header (JLC1)	89
M.2 M-Key PCIe 5.0 x2 Slots	90

MCIO NVMe Connectors	90
MCIO PCIe 5.0 x8 Connectors	90
NC-SI Connection	90
NVMe SMBus Header	91
NVMe VPP Bus Connector	91
TPM/Port 80 Header	91
VROC RAID Key Header	92
Control Panel	92
Front Control Panel Header with I ² C	93
Power On and BMC/BIOS Status LED Button	93
UID LED	94
Fail LED (Information LED for OH/FF/PF)	94
LAN1/LAN2 (NIC1/NIC2) LED	95
Storage Drive Activity LED	95
Standby Power LED	95
Root of Trust (RoT) Power LED	96
Standby Power	96
Power Fail LED Indicators	96
FP USB Power	96
Front Control Panel Header 2	97
I/O Connectors/Ports	97
Advanced I/O Module (AIOM) for I/O Support	97
AIOM Sideband Connector (JAIOMSB1)	97
BMC LAN/USB/VGA Connector	97
Universal Serial Bus (USB) 3.2 Header	98
VGA Connection Ports	98
Jumper Settings	99
CMOS Clear	99
UID LED and System_Reset Button Select Jumper	100
LED Indicators	100
BMC Heartbeat LED	100
BMC LAN LEDs	101
Onboard Power LED	101
Unit ID (UID) LED	101

Chapter 3: Troubleshooting	102
3.1 Troubleshooting Procedures	103
Before Power On	103
No Power	103
No Video	103
System Boot Failure	103
Memory Errors	104
Losing the System's Setup Configuration	104
If the System Becomes Unstable	104
3.2 Technical Support Procedures	106
3.3 Frequently Asked Questions	107
3.4 Returning Merchandise for Service	108
Chapter 4: UEFI BIOS	109
4.1 Introduction	110
Updating BIOS	110
Starting the Setup Utility	110
4.2 Main Setup	112
4.3 Advanced Setup Configurations	114
Boot Feature Menu	114
CPU Configuration Menu	115
Advanced Power Management Configuration Menu	118
CPU P State Control Menu	118
Hardware PM State Control Menu	120
CPU C State Control Menu	120
Package C State Control Menu	121
CPU1/CPU2 Core Disable Bitmap Menu	122
Chipset Configuration Menu	122
Uncore Configuration Menu	122
Memory Configuration Menu	124
Memory Topology Menu	125
Memory Map Menu	125
Memory RAS Configuration Menu	125
Security Configuration Menu	127
IIO Configuration Menu	133

CPU1/CPU2 Configuration Menu	133
Intel VT for Directed I/O (VT-d) Menu	135
PCIe Leaky Bucket Configuration Menu	135
Trusted Computing Menu	136
ACPI Settings Menu	137
Super IO Configuration Menu	137
Serial Port 1 Configuration Menu	138
Serial Port 2 Configuration Menu	138
Serial Port Console Redirection Menu	139
Network Stack Configuration Menu	143
MAC:(MAC address)-IPv4 Network Configuration Menu	144
MAC:(MAC address)-IPv6 Network Configuration Menu	145
PCIe/PCI/PnP Configuration Menu	146
HTTP Boot Configuration Menu	147
Supermicro KMS Server Configuration Menu	148
Super-Guardians Configuration Menu	150
TLS Authenticate Configuration Menu	152
Driver Health Menu	153
4.4 Event Logs	154
4.5 BMC	156
System Event Log Menu	156
BMC Network Configuration Menu	157
4.6 Security	160
Secure Boot Menu	161
4.7 Boot	164
4.8 Save & Exit	166
Appendix A: Software	168
Microsoft Windows OS Installation	168
Installing the OS	168
A.1 Driver Installation	171
BMC	173
BMC ADMIN User Password	173
Logging into the BMC	173

***Appendix B: Standardized Warning Statements* 174**
Battery Handling 174
Product Disposal 176

Contacting Supermicro

Headquarters

Address: Super Micro Computer, Inc.
980 Rock Ave.
San Jose, CA 95131 U.S.A.

Tel: +1 (408) 503-8000

Fax: +1 (408) 503-8008

Email: Marketing@supermicro.com (General Information)
Sales-USA@supermicro.com (Sales Inquiries)
Government_Sales-USA@supermicro.com (Gov. Sales Inquiries)
Support@supermicro.com (Technical Support)
RMA@Supermicro.com (RMA Support)
Webmaster@supermicro.com (Webmaster)

Website: <https://www.supermicro.com>

Europe

Address: Super Micro Computer B.V.
Het Sterrenbeeld 28, 5215 ML
's-Hertogenbosch, The Netherlands

Tel: +31 (0) 73-6400390

Fax: +31 (0) 73-6416525

Email: Sales_Europe@supermicro.com (Sales Inquiries)
Support_Europe@supermicro.com (Technical Support)
RMA_Europe@supermicro.com (RMA Support)

Website: <https://www.supermicro.nl>

Asia-Pacific

Address: Super Micro Computer, Inc.
3F, No. 150, Jian 1st Rd.
Zhonghe Dist., New Taipei City 235 Taiwan (R.O.C)

Tel: +886 (2) 8226-3990

Fax: +886 (2) 8226-3992

Email: Sales-Asia@supermicro.com.tw (Sales Inquiries)
Support@supermicro.com.tw (Technical Support)
RMA@supermicro.com.tw (RMA Support)

Website: <https://www.supermicro.com.tw>

Chapter 1:

Introduction

Congratulations on purchasing your computer motherboard from an industry leader. Supermicro motherboards are designed to provide you with the highest standards in quality and performance.

1.1 Quick Reference	13
Motherboard Layout	13
Quick Reference Table	14
Memory Slots	17
Motherboard Features	18
Motherboard Block Diagram	22
1.2 Platform Overview	23
Flexible and Scalable Processor Architectural Design	23
New Software Capability and Performance Optimization	23
1.3 Special Features	24
Recovery from AC Power Loss	24
1.4 System Health Monitoring	25
Onboard Voltage Monitors	25
Fan Status Monitor with Firmware Control	25
Environmental Temperature Control	25
1.5 ACPI Features	26
1.6 Serial Port	27

1.1 Quick Reference

For details on the X14DBM-SP motherboard layout, features, and other quick reference information, refer to the content below.

Motherboard Layout

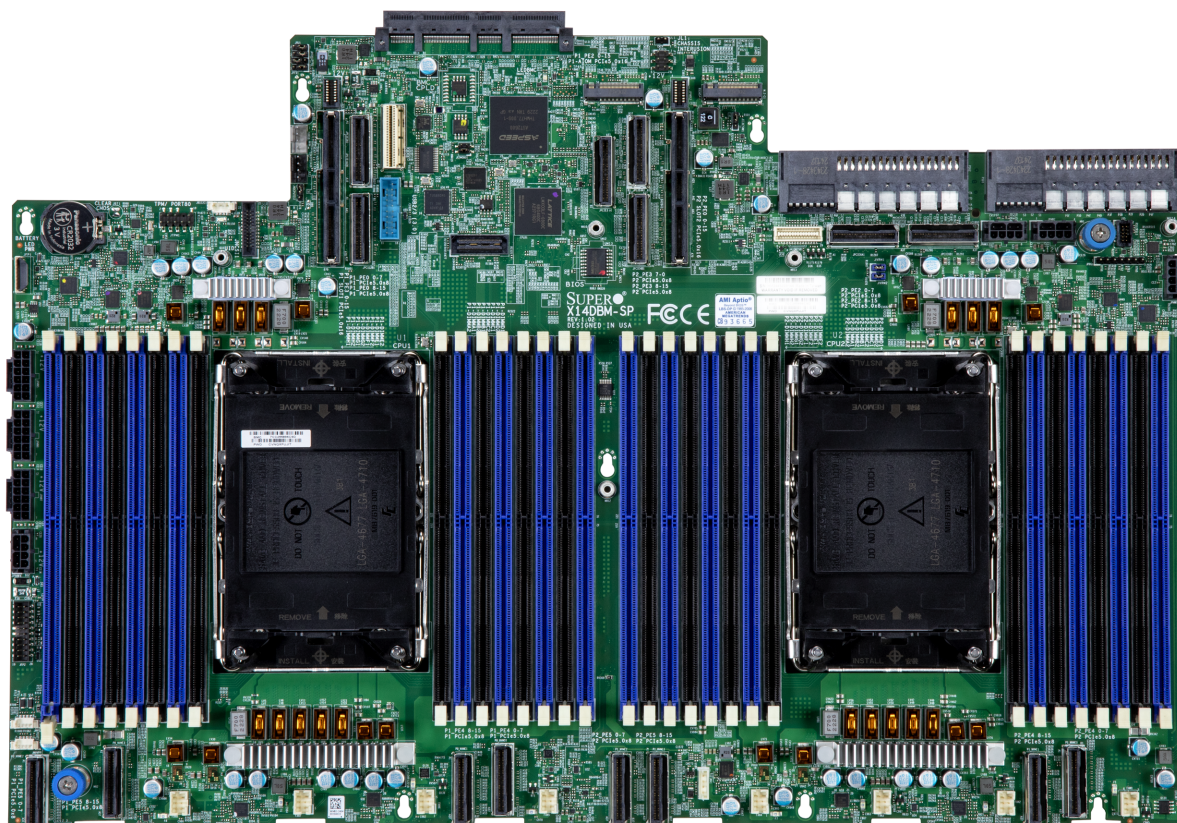

Figure 1-1. X14DBM-SP Motherboard Image

Note: All graphics shown in this manual were based upon the latest PCB revision available at the time of publication of the manual. The motherboard you received may or may not look exactly the same as the graphics shown in this manual.

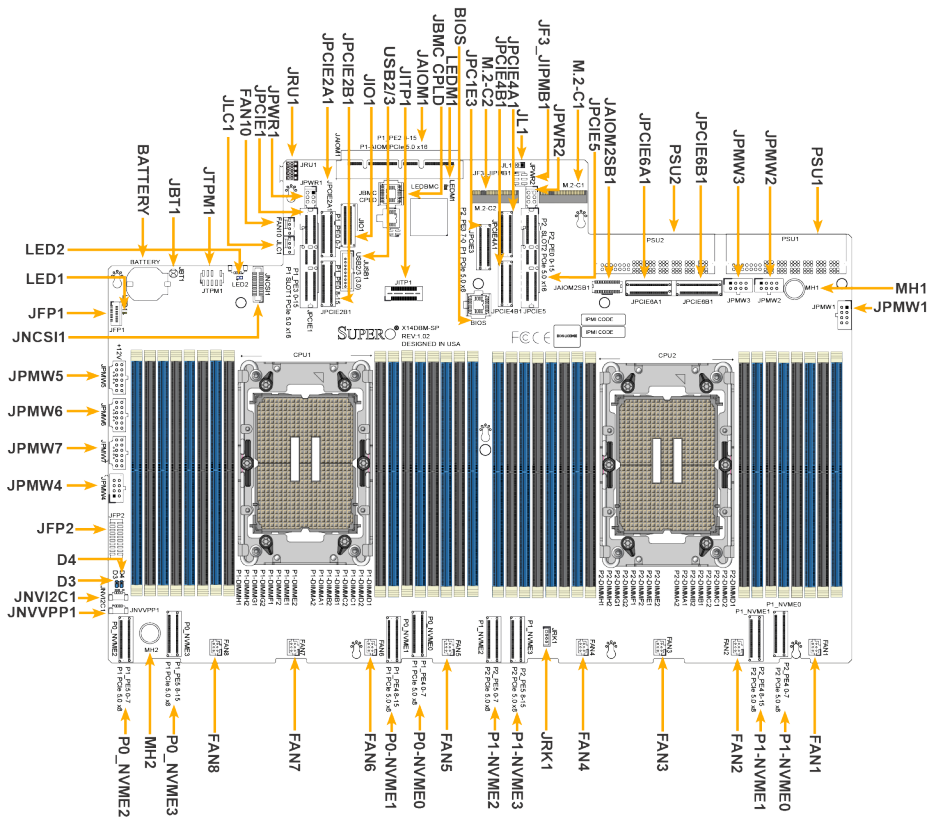

Figure 1-2. X14DBM-SP Motherboard Layout

Notes:

- For detailed information on jumpers, connectors, and LED indicators, see "Component Installation" on page 28.
- "■" indicates the location of pin 1.
- Components not documented are for internal testing purposes only.
- Use only the correct type of onboard CMOS battery as specified by the manufacturer. To avoid possible explosion, do not install the onboard battery upside down.

Quick Reference Table

Jumper	Description	Jumper Setting
JBT1	CMOS Clear	Open (Normal)

LED	Description	Status
LED1 (LEDPWR)	Onboard Power LED	LED On: Onboard Power On

LED	Description	Status
LED2 (UID-LED)	Unit Identifier (UID) LED	Solid Blue: Unit Identified
LEDM1 (LEDBMC)	BMC Heartbeat LED	Blinking Green: BMC Normal (Active) Solid Green: (During BMC Reset or during a Cold Reboot)

Connector	Description
Battery (BT1)	Onboard Battery
FAN1–FAN8, FAN10	Eight 6-pin Cooling Fan Headers (FAN1–FAN8) and one 4-pin Cooling Fan Header (FAN10)
JAIOM1 (P1_PE2 0–15)	Advanced Input/Output Module (AIOM) PCIe 5.0 x16 Connector for I/O Support
JAIOMSB1 (P1_PE0 0–15)	Advanced Input/Output Module (AIOM2) Sideband Connector PCIe 5.0 x16 AIOM (OCP3.0-compliant) Slot
JJF3_JIPMB1 (JIPMB1)	6-pin BMC External I ² C Header
JFP1	Front Control Panel Header
JFP2	Front Control Panel Header 2
JIO1 (BMCLAN/USB/VGA)	Low-profile (LP) Slim SAS I/O Connector
JL1	Chassis Intrusion Header
JLC1	Liquid Leak Check Header
JPCIE1 (P1_PE3 0–15)	(P1-SLOT1) PCIe 5.0 x16 Slot
JPCIE2A1 (P1_PE0 0–7)	MCIO (P1) PCIe 5.0 x8 Connector
JPCIE2B1 (P1_PE0 8–15)	MCIO (P1) PCIe 5.0 x8 Connector
JPCIE3	MCIO (P2) PCIe 5.0 x8 Connector
JPCIE4A1 (P2_PE3 7–0)	MCIO (P2) PCIe 5.0 x8 Connector

Connector	Description
JPCIE4B1 (P2_PE3 8–15)	MCIO (P2) PCIe 5.0 x8 Connector
JPCIE5 (P2_PE0 0–15)	(P2 SLOT2) PCIe 5.0 x16 Slot
JPCIE6A1 (P2_PE2 0–7)	MCIO (P2) PCIe 5.0 x8 Connector
JPCIE6B1 (P2_PE2 8–15)	MCIO (P2) PCIe 5.0 x8 Connector
JPMW1–JPMW4	8-pin +12 V Power Connectors
JPMW5–JPMW7	16-pin +12 V Power Connectors
JPWR1–JPWR2	6-pin +12 V Power Connectors
PSU1/PSU2	Power Supply Unit1/Unit2
JNCSI	Network Controller Sideband Interface (NC-SI) Connector
JNVI ² C1	NVMe SMBus I ² C Header
JNVVPP1	NVMe VPP System Management Bus (SMBus)
JRU1	UID LED and System_Reset Button Select Jumper
JTPM1	Trusted Platform Module/Port 80 Connector
M.2-C1/M.2-C2	M.2 M-Key PCIe 5.0 x2 Slots (2280/22110)
P0_NVME0 (P1_PE4 0–7)	MCIO P1_PCl e 5.0 x8 Connectors with NVMe Connections 0–7
P0_NVME1 (P1_PE4 8–15)	MCIO P1_PCl e 5.0 x8 Connectors with NVMe Connections 8–15
P0_NVME2 (P1_PE5 0–7)	MCIO P1_PCl e 5.0 x8 Connectors with NVMe Connections 0–7
P0_NVME3 (P1_PE5 8–15)	MCIO P1_PCl e 5.0 x8 Connectors with NVMe Connections 8–15
P1_NVME0 (P2_PE4 0–7)	MCIO P2_PCl e 5.0 x8 Connectors with NVMe Connections 0–7

Connector	Description
P1_NVME1 (P2_PE4 8–15)	MCIO P2_PCl e 5.0 x8 Connectors with NVMe Connections 8–15
P1_NVME2 (P2_PE5 0–7)	MCIO P2_PCl e 5.0 x8 Connectors with NVMe Connections 0–7
P1_NVME3 (P2_PE5 8–15)	MCIO P2_PCl e 5.0 x8 Connectors with NVMe Connections 8–15
USB2/3 (3.0) (JUSB1)	USB header with support for two USB 3.2 Gen 1 ports
VROC RAID Key (JRK1)	Intel VROC RAID Key Header

Notes:

- For details on how to configure Network Interface Card (NIC) settings, refer to the Network Interface Card Configuration User's Guide posted on our website under the link: <https://www.supermicro.com/support/manuals>.
- For detailed instructions on how to configure VROC RAID settings, refer to the VROC RAID Configuration User's Guide posted on the web page under the link: <https://www.supermicro.com/support/manuals>.

Memory Slots

This motherboard supports up to 4 TB of ECC DDR5 RDIMM/RDIMM 3DS/MR DIMM memory with speeds of up to 6400 MT/s (1DPC) or up to 5200 MT/s (2DPC) in 32 DIMM slots.

DIMM Slots Supported by CPU1	DIMM Slots Supported by CPU2
P1-DIMMA1	P2-DIMMA1
P1-DIMMA2	P2-DIMMA2
P1-DIMMB1	P2-DIMMB1
P1-DIMMB2	P2-DIMMB2
P1-DIMMC1	P2-DIMMC1
P1-DIMMC2	P2-DIMMC2
P1-DIMMD1	P2-DIMMD1
P1-DIMMD2	P2-DIMMD2
P1-DIMME1	P2-DIMME1

DIMM Slots Supported by CPU1	DIMM Slots Supported by CPU2
P1-DIMME2	P2-DIMME2
P1-DIMMF1	P2-DIMMF1
P1-DIMMF2	P2-DIMMF2
P1-DIMMG1	P2-DIMMG1
P1-DIMMG2	P2-DIMMG2
P1-DIMMH1	P2-DIMMH1
P1-DIMMH2	P2-DIMMH2

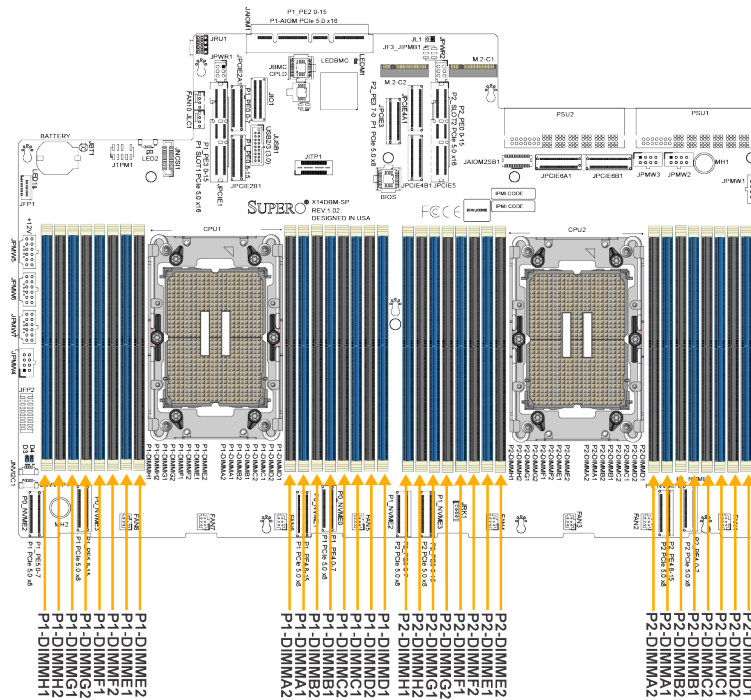

Figure 1-3. Memory Slots

Motherboard Features

Motherboard Features
Processor
<ul style="list-style-type: none"> Supports dual Intel® Xeon® 6700-series processors with E-cores (in LGA 4710 Socket E2) with four UPIs (24 GT/s max.) and a thermal design power (TDP) up to 330 W Supports dual Intel® Xeon® 6700-series processors with P-cores (XCC, LCC & HCC SKUs) with four UPIs (24 GT/s max.) and a thermal design power (TDP) up to 350 W

Motherboard Features
<p>Memory</p> <ul style="list-style-type: none"> • Supports up to 4 TB of ECC DDR5 RDIMM memory with speeds of up to 6400 MT/s (1DPC) or up to 5200 MT/s (2DPC) in 32 DIMM slots. • When the Intel Xeon 6700-series processors with E-cores are installed, the X14DBM-SP motherboard also supports MRDIMM DDR5 memory with speeds up to 8000 MT/s in 1DPC configurations.
<p>DIMM Size</p> <ul style="list-style-type: none"> • 32 GB, 64 GB, 96 GB, and 128 GB <p>Note: For the latest processor/memory updates, refer to our website at https://www.supermicro.com/en/products/motherboards.</p>
<p>Expansion Slots</p> <ul style="list-style-type: none"> • Up to 88 PCIe 5.0 lanes (PCIe or CXL) per processor, including: <ul style="list-style-type: none"> • Two GenZ 4C CONN for two PCIe 5.0 x16 • One GenZ 4C+ for two AIOM (Advanced IO Module) • 15 MCIO CONN for eight PCIe 5.0 X8 • Two M.2 M-key PCIe 5.0 x2 (with support for 2280 and 22110 form factor) • Two USB 3.1 (Header)/two USB 3.0 (IO Board)
<p>Baseboard Management Controller (BMC)/Network</p> <ul style="list-style-type: none"> • ASPEED AST2600 BMC • One dedicated BMC LAN/VGA (via AST2600 BMC HW RoT)
<p>Graphics</p> <ul style="list-style-type: none"> • Graphics controller and VGA support via ASPEED AST2600 BMC
<p>I/O Devices</p> <ul style="list-style-type: none"> • One VGA connection header (JFP2): used for dedicated VGA via BMC and for front accessible VGA connection • One LP (low-profile) SlimSAS x8 I/O connector (JIO1): used for I/O mezzanine card from a cable to provide VGA/COM/USB*2/RJ45 (dedicated BMC LAN) connections
<p>Peripheral Devices</p> <ul style="list-style-type: none"> • Two USB 2.0 ports on the I/O riser board via a cable • One USB 3.2 Gen1 (5 Gbps) header on the motherboard with support for two USB connections

Motherboard Features
BIOS
<ul style="list-style-type: none"> • AMI SPI BIOS® • NAND Flash 64/256 Mb support • SPI dual/quad speed control, RTC (Real Time Clock) wakeup, riser card auto detection support, IPMIView, SMCIPMITOOL, IPMI CFG, Redundant power supply unit detection, SPM, SUM-OOB/InBand
Power Connections
<ul style="list-style-type: none"> • Two power supply units (PSU1/PSU2) (Main server power) • Two 6-pin 12 V power connectors (JPWR1/JPWR2) (for riser cards) • Four 8-pin 12 V power connectors (JPMW1–JPMW4) (for backplane or GPU devices) • Three 16-pin 12 V power connectors (JPMW5–JPMW7) (for backplane or GPU devices)
Power Management
<ul style="list-style-type: none"> • ACPI power management • S1, S5 support • Power button override mechanism • Power-on mode for AC power recovery • Wake-on-LAN • Power supply monitoring
System Health Monitoring
<ul style="list-style-type: none"> • Onboard voltage monitoring for +3.3 V, +3.3 V Standby, +5 V, +5 V Standby, +12 V, Vcore, Vmem • Onboard temperature monitoring for CPU, GPU, VRM, LAN, system, peripheral, memory, NIC, M.2 SSD, AOM, and NVMe devices • 8 processor switch phase voltage regulator • Processor thermal trip support • Platform Environment Control Interface (PECI)

Motherboard Features
Fan Control
<ul style="list-style-type: none"> • Fan status monitoring via BMC connections • Three cooling zones • Low-noise fan speed control • 6-pin proprietary fans and 4-pin fans supported
System Management
<ul style="list-style-type: none"> • Chassis intrusion header and detection • Server platform service • RoHS support
Firmware Integrity/System Security
<ul style="list-style-type: none"> • Trusted Platform Module (TPM) support • Root of Trust (RoT) support to protect firmware security by detecting critical data corruption, and restoring platform integrity
LED Indicators
<ul style="list-style-type: none"> • Processor/system overheat LED • Power/suspend state indicator LED • Fan-Failed LED • UID/remote UID • HDD activity LED • LAN activity LED • BMC/CPLD firmware LED
Dimensions
10.75" x 17.0" (273.05 mm x 431.80 mm) (L x W) Proprietary

Notes:

- The processor maximum Thermal Design Power (TDP) is subject to chassis and heatsink cooling restrictions, and it also depends on server SKUs. For proper thermal management, check the chassis and heatsink specifications.
- For BMC configuration instructions, refer to the Embedded BMC Configuration User's Guide available at <https://www.supermicro.com/support/manuals>.

Motherboard Block Diagram

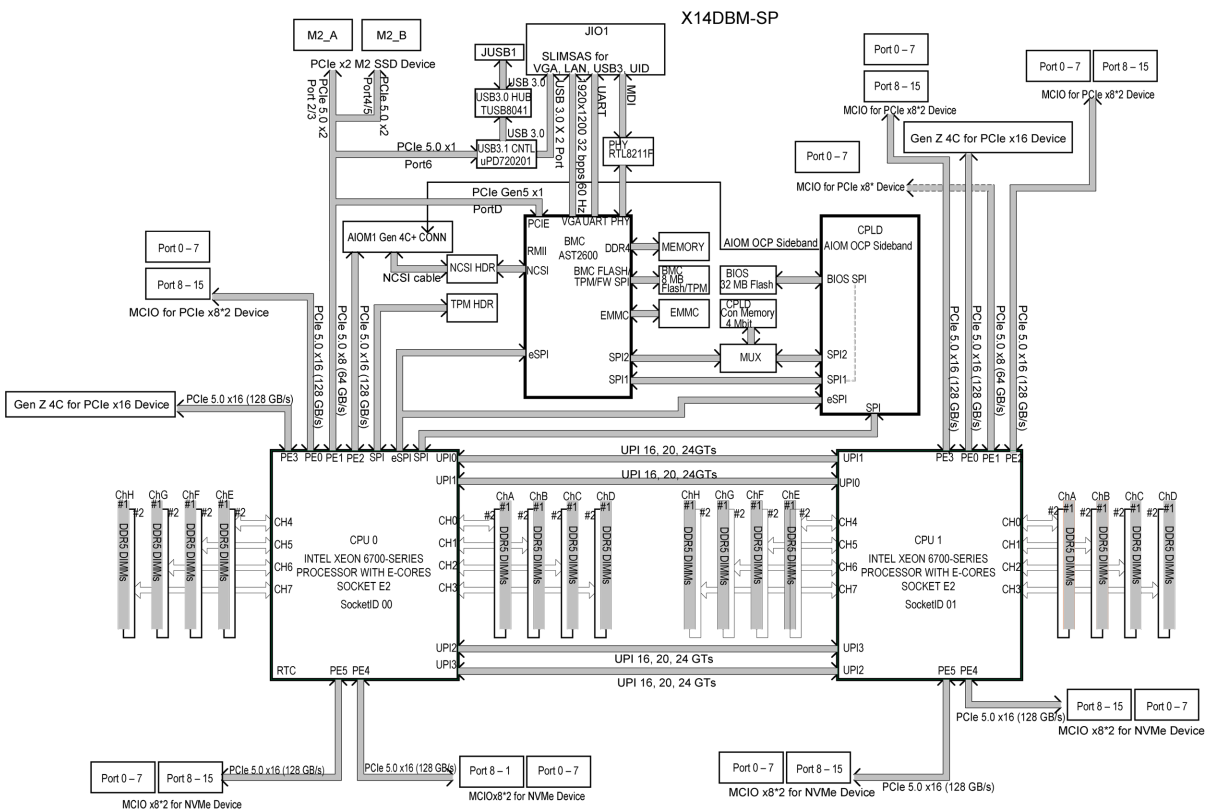

Figure 1-4. System Block Diagram

Note: This is a general block diagram and may not exactly represent the features on your motherboard. For the actual specifications of your motherboard, see the previous pages.

1.2 Platform Overview

Built upon the capability of the Intel® Xeon® 6 processors, the X14DBM-SP motherboard provides system performance, power efficiency, and feature sets to address the needs of next-generation computer users.

The X14DBM-SP motherboard dramatically increases system performance for a multitude of server applications and supports the following features:

Flexible and Scalable Processor Architectural Design

The Intel® Xeon® 6 processors are built upon System-on-Chip (SoC) modular design, which offers computer systems with flexible, unrestrictive expansion options.

- Separate Compute and IO silicon chipsets
- Modular die fabric that enables flexible construction
- EmiB packaging with high bandwidth/low latency support
- Common IP, Firmware, OS, and platform ingredients
- Processor scalability: P-core (1S-8S) and E-core (1S-2S) supported (with P-core optimized for performance, and E-core, for efficiency)
- A wide range of core counts and thermals supported
- Memory: up to eight channels of DDR/MCR with one or two DIMM per channel support
- Advanced I/O up to 136 lanes, PCIe 5.0/CXL 2.0, up to 6 UPI links (144 lanes) support
- Self-boot capability

New Software Capability and Performance Optimization

- AMX supports Floating Point 16-bit format (FP16) for AI/ML
- 2 K memory encryption keys with 256b strength
- 64 KB, 16-way I-cache with improved branch predictor and miss recovery
- More outstanding memory requests and prefetch capabilities
- New Intel Xeon Architecture optimized for power efficiency and performance built on the latest Intel 3 process

1.3 Special Features

Recovery from AC Power Loss

The Basic I/O System (BIOS) provides a setting that determines how the system will respond when AC power is lost and then restored to the system. You can choose for the system to remain powered off (in which case you must press the power switch to turn it back on), or for it to automatically return to the power-on state. See Advanced Setup Configurations under "[UEFI BIOS](#)" on [page 109](#) for this setting. The default setting is **Last State**.

1.4 System Health Monitoring

Onboard Voltage Monitors

An onboard voltage monitor will continuously scan the voltages of the onboard chipset, memory, processor, and battery. Once a voltage becomes unstable, a warning is given or an error message is sent to the screen. You can adjust the voltage thresholds to define the sensitivity of the voltage monitor. Real time voltage levels are displayed in IPMI.

Fan Status Monitor with Firmware Control

The system health monitor embedded in the BMC chip can check the RPM status of the cooling fans. The processor and chassis fans are controlled via IPMI.

Environmental Temperature Control

System Health sensors in the BMC monitor the temperatures and voltage settings of onboard processors and the system in real time via the IPMI interface. Whenever the temperature of the processor or the system exceeds a user-defined threshold, system/processor cooling fans will be turned on to prevent the processor or the system from overheating.

Note: To avoid possible system overheating, be sure to provide adequate airflow to your system.

1.5 ACPI Features

ACPI stands for Advanced Configuration and Power Interface. The ACPI specification defines a flexible and abstract hardware interface that provides a standard way to integrate power management features throughout a computer system, including its hardware, operating system and application software. This enables the system to automatically turn on and off peripherals such as network cards, hard disk drives, and printers.

In addition to enabling operating system-directed power management, ACPI also provides a generic system event mechanism for Plug and Play, an operating system-independent interface for configuration control. ACPI leverages the Plug and Play BIOS data structures while providing a processor architecture-independent implementation that is compatible with Windows Server 2022.

1.6 Serial Port

The X14DBM-SP motherboard supports one serial port via a header on the I/O board. COM Port 1 is used for input/output. The UART provides legacy speeds with a baud rate of up to 115.2 Kbps.

Chapter 2:

Component Installation

This chapter provides instructions on installing and replacing main system components for the X14DBM-SP motherboard. To prevent compatibility issues, only use components that match the specifications and/or part numbers given.

Installation or replacement of most components require that power first be removed from the system. Follow the procedures given in each section.

2.1 Static-Sensitive Devices	30
Precautions	30
Unpacking	30
2.2 Motherboard Installation	31
Mounting Holes/T-pin Cutouts/Heatsink Standoffs	31
Installing the Motherboard	34
2.3 Processor and Heatsink Installation	36
LGA 4710 Socket E2 Processors	36
Overview of the Processor Socket	37
Overview of the Processor Carrier	37
Overview of the Processor Heatsink Module	39
Installing the Processor	42
Assembling the Processor Heatsink Module	44
Preparing the Processor Socket for Installation	51
Preparing to Install the PHM into the Processor Socket	52
Installing the Processor Heatsink Module	55
Removing the Processor Heatsink Module	63
2.4 Memory Support and Installation	73
Memory Support	73
General Guidelines for Optimizing Memory Performance	81
DIMM Installation	82
DIMM Removal	84
2.5 Battery Removal and Installation	85
Battery Removal	85

Proper Battery Disposal	85
Battery Installation	85
2.6 Connections, Jumpers, and LEDs	86
Power Supply and Power Connections	86
Headers and Connections	88
Control Panel	92
I/O Connectors/Ports	97
Jumper Settings	99
LED Indicators	100

2.1 Static-Sensitive Devices

Electrostatic Discharge (ESD) can damage electronic components. To avoid damaging your motherboard, it is important to handle it very carefully. The following measures are generally sufficient to protect your equipment from ESD.

Precautions

- Use a grounded wrist strap designed to prevent static discharge.
- Touch a grounded metal object before removing the board from the antistatic bag.
- Handle the motherboard only by its edges. Do not touch its components, peripheral chips, memory modules, or gold contacts.
- When handling chips or modules, avoid touching their pins.
- Put the motherboard and peripherals back into their antistatic bags when not in use.
- For grounding purposes, make sure that your computer chassis provides excellent conductivity between the power supply, the case, the mounting fasteners, and the motherboard.
- Use only the correct type of onboard CMOS battery. To avoid possible explosion, do not install the onboard battery upside down.

Unpacking

To avoid static damage, the motherboard is shipped in antistatic packaging. When unpacking the motherboard, make sure that the person handling it is static protected.

2.2 Motherboard Installation

All motherboards have standard mounting holes to fit different types of chassis. Make sure that the locations of all the mounting holes for both the motherboard and the chassis match. Although a chassis may have both plastic and metal mounting fasteners, metal ones are highly recommended because they ground the motherboard to the chassis. Make sure that the metal standoffs click in or are screwed in tightly.

Before installing the motherboard in the chassis, carefully read the instructions below.

Notes:

- To avoid damaging the motherboard and its components, do not use a force greater than 8 lbf-in on each mounting screw during motherboard installation.
- Some components are very close to the mounting holes. Take precautionary measures to avoid damaging these components when installing the motherboard to the chassis.

Mounting Holes/T-pin Cutouts/Heatsink Standoffs

The following section provides information on mounting holes, T-pin cutouts, and heatsink standoffs on this motherboard.

1. Mounting holes for built-in thumbscrews (2: MH1, MH2)

Two mounting holes with built-in thumbscrews are used to help attach the motherboard onto the chassis.

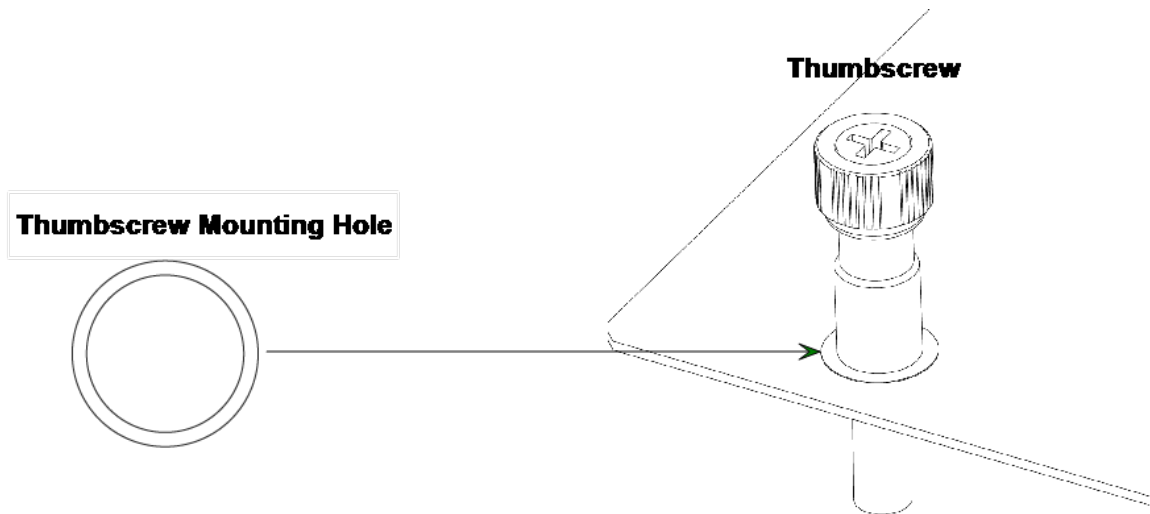

Figure 2-1. Thumbscrew and the Thumbscrew Mounting Hole

2. T-pin Cutouts (7)

Seven cutouts are used with T-pins on the chassis to help lock the motherboard onto the chassis.

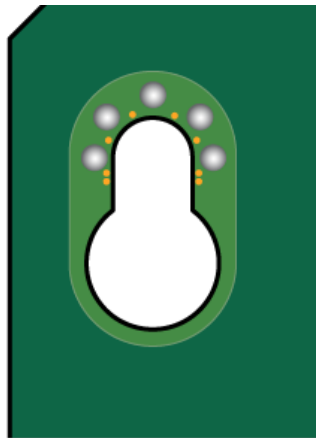

Figure 2-2. T-pin Figure (Left) and the Colored T-pin (Right)

3. Heatsink Standoffs (5: MH10, MH11, MH12, MH13, MH14)

Five standoffs are used to secure the optional EVCA-Ext. heatsink onto the motherboard.

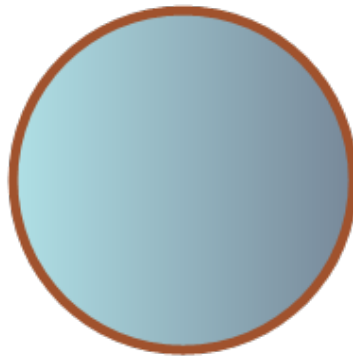

Figure 2-3. Heatsink Standoff

Note: The standoffs located at MH10–MH14 are used for the optional EVCA-Ext heatsinks only.

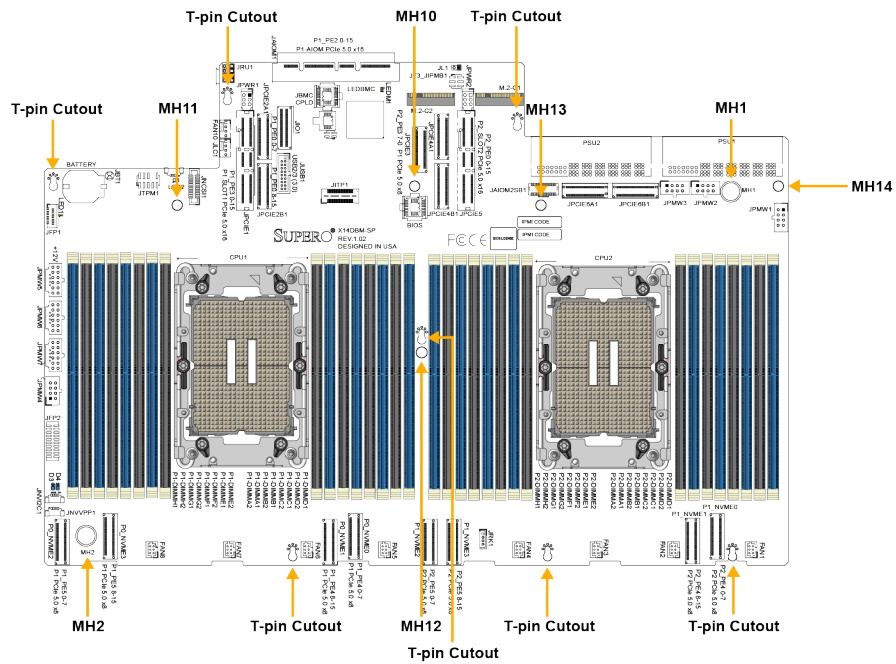

Figure 2-4. Locations of Mounting Holes/T-pin Cutouts/Heatsink Standoffs

Installing the Motherboard

1. Install the I/O shield into the back of the chassis, if applicable.

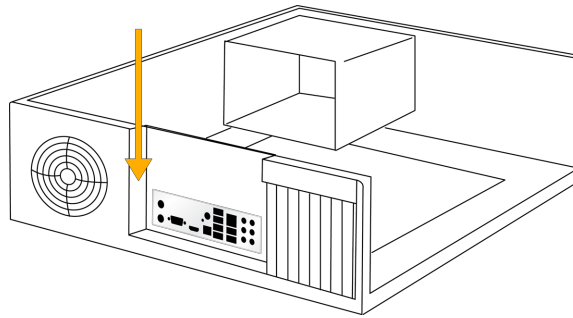

Figure 2-5. Installing the I/O Shield

Note: Images displayed are for illustration purposes only. The components installed in your system may or may not look exactly the same as the graphics shown in the manual.

2. Locate the mounting holes on the motherboard. See Motherboard Installation for the location.

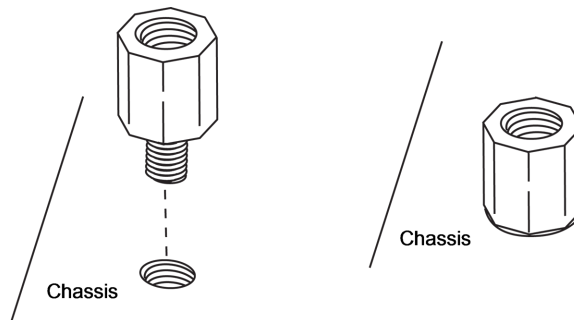

Figure 2-6. Locating the Mounting Holes

3. Locate the matching mounting holes on the chassis. Align the mounting holes on the motherboard against the mounting holes on the chassis.

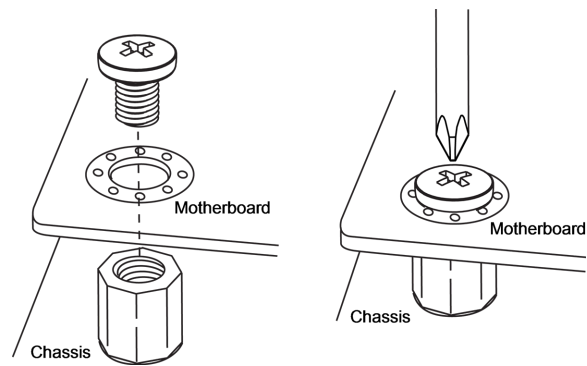

Figure 2-7. Aligning the Mounting Holes

4. Install standoffs in the chassis as needed.
5. Install the motherboard into the chassis carefully to avoid damaging other motherboard components.
6. Insert pan head #6 screws into the mounting holes on the motherboard and the matching mounting holes on the chassis.
7. Make sure that the motherboard is securely placed in the chassis.

2.3 Processor and Heatsink Installation

This section provides procedures to install the processor(s) and heatsink(s).

Notes:

- Take industry standard precautions to avoid ESD damage. For details, see "[Static-Sensitive Devices](#)" on page 30.
- Before starting, make sure that the plastic socket cap is in place and none of the socket pins are bent. If any damage is noted, contact your retailer.
- Do not connect the system power cord before the processor and heatsink installation is complete.
- When handling the processor, avoid touching or placing direct pressure on the LGA lands (gold contacts). Improper installation or socket misalignment can cause serious damage to the processor or processor socket.
- Install the processor in the socket and the motherboard into the chassis before installing the heatsink.
- When buying a processor separately, use only a Supermicro certified heatsink.
- Refer to the Supermicro website for the most recent processor support.
- When installing the heatsink, ensure a torque driver set to the correct force is used for each screw.
- Thermal grease is pre-applied on a new heatsink. No additional thermal grease is needed.

LGA 4710 Socket E2 Processors

Processor Top View

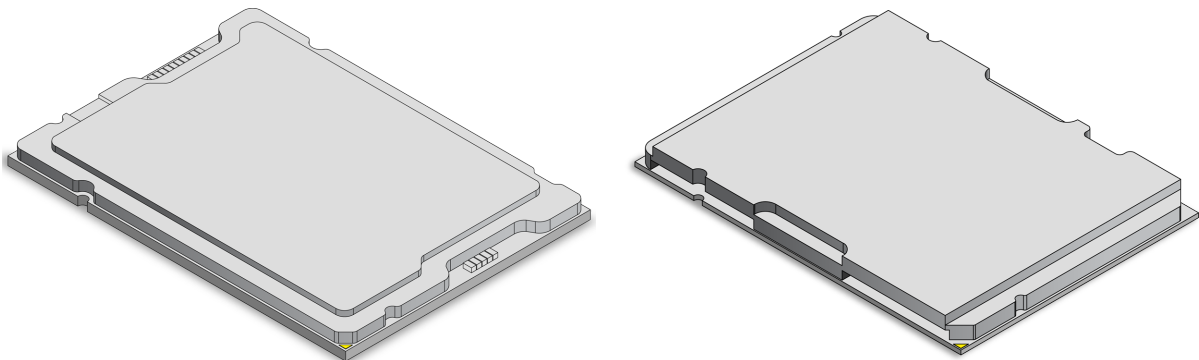

Figure 2-8. Processor (SP XCC left, SP HCC/LCC right)

Note: The motherboard supports three processor SKUs: SP XCC, SP HCC, and SP LCC. Each SKU supports a specific carrier; the SP XCC processor supports Carrier E2A while SP HCC and SP LCC support Carrier E2B. Make sure the processors of the same SKU are on the motherboard.

Overview of the Processor Socket

The processor socket is protected by a plastic protective cover.

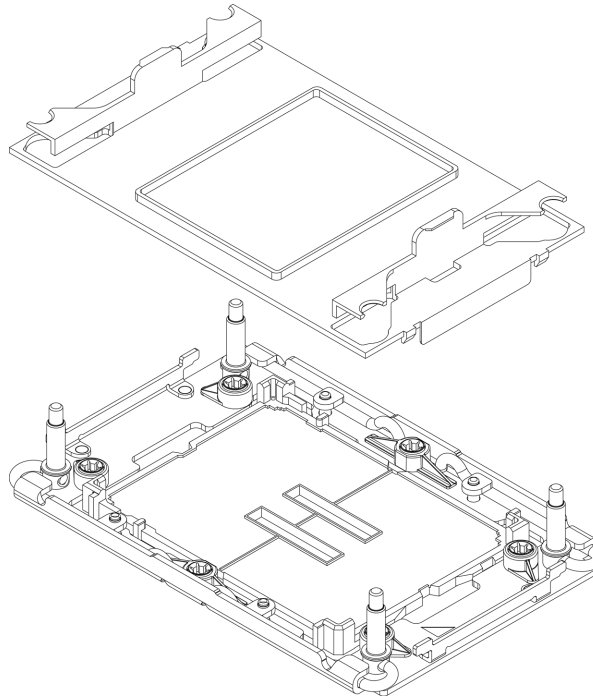

Figure 2-9. Plastic Protective Cover and Processor Socket

Overview of the Processor Carrier

The motherboard supports two types of processors and their associated processor carrier.

Processor Carriers

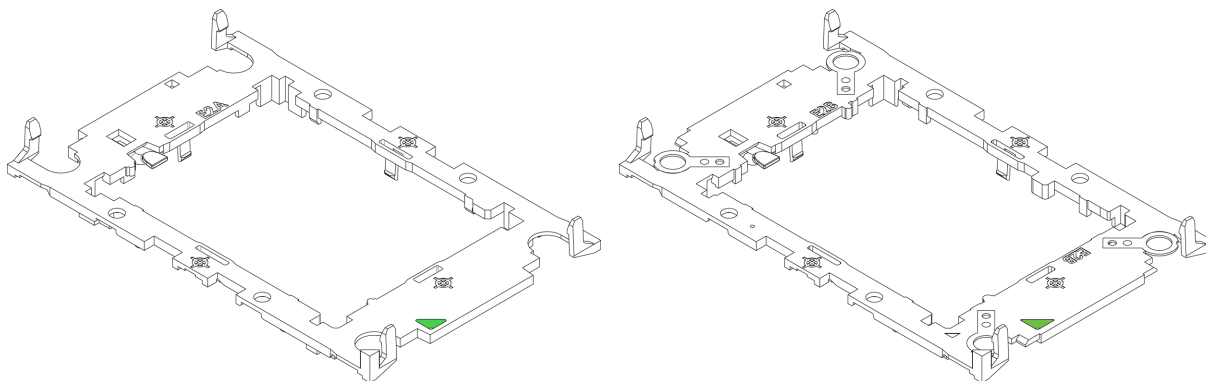

Figure 2-10. Carrier (SP XCC E2A left, SP HCC/LCC E2B right)

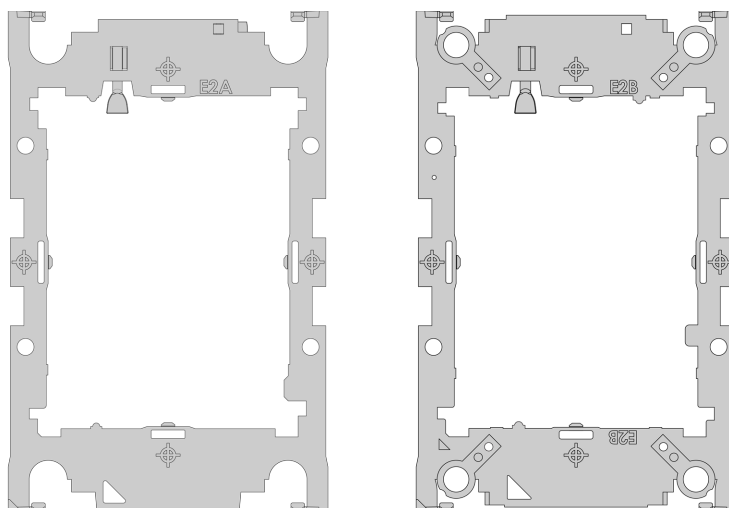

Figure 2-11. Carrier Top View (SP XCC E2A left, SP HCC/LCC E2B right)

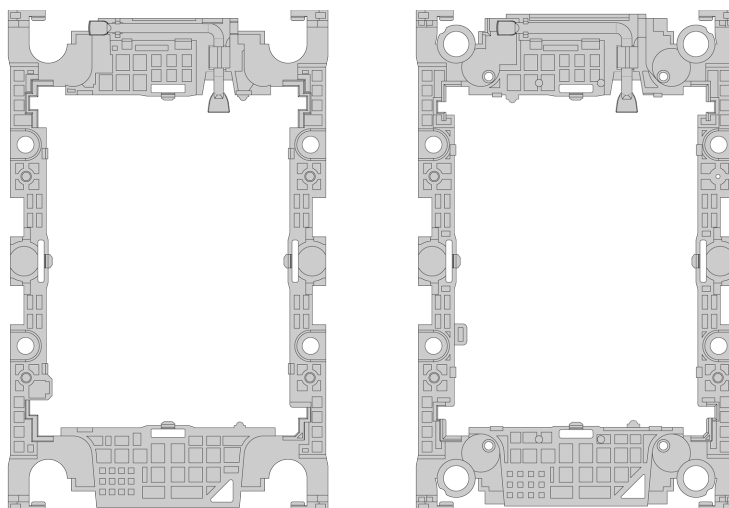

Figure 2-12. Carrier Bottom View (SP XCC E2A left, SP HCC/LCC E2B right)

Overview of the Processor Heatsink Module

The Processor Heatsink Module (PHM) contains a heatsink, a processor carrier, and the processor.

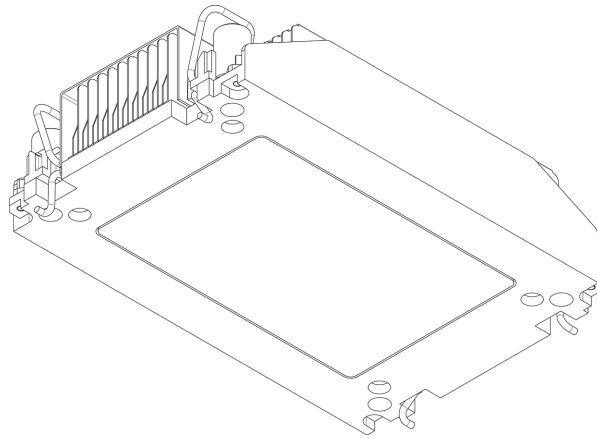

Figure 2-13. Heatsink (1U)

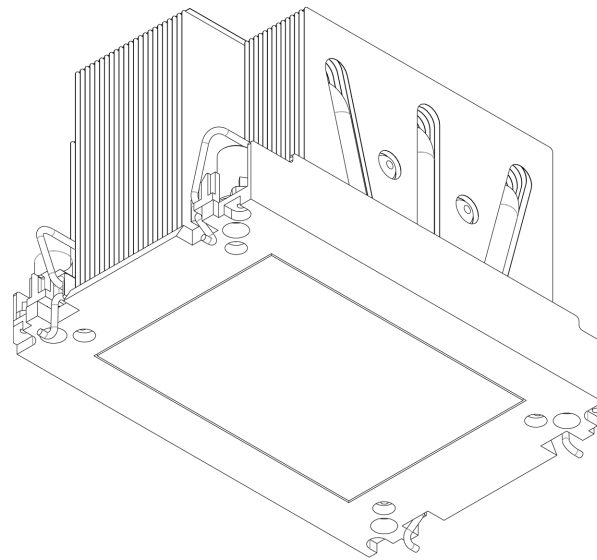

Figure 2-14. Heatsink (2U)

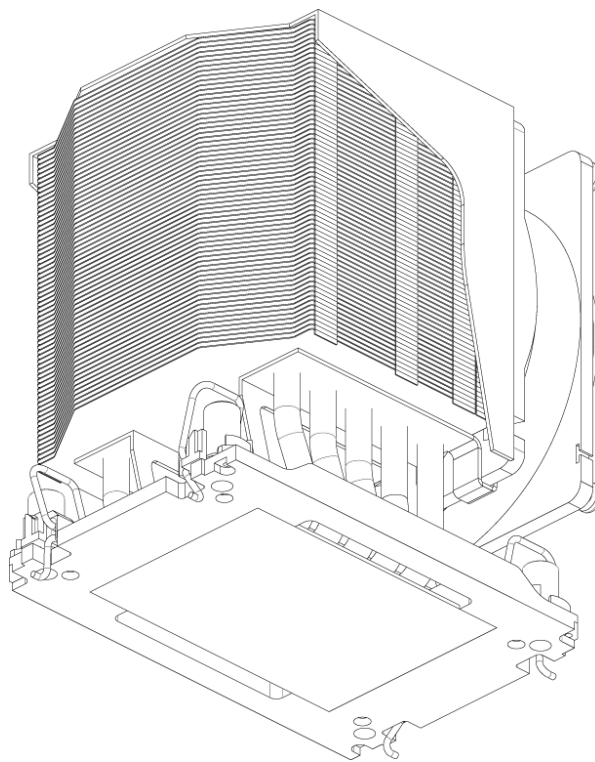

Figure 2-15. Heatsink (4U)

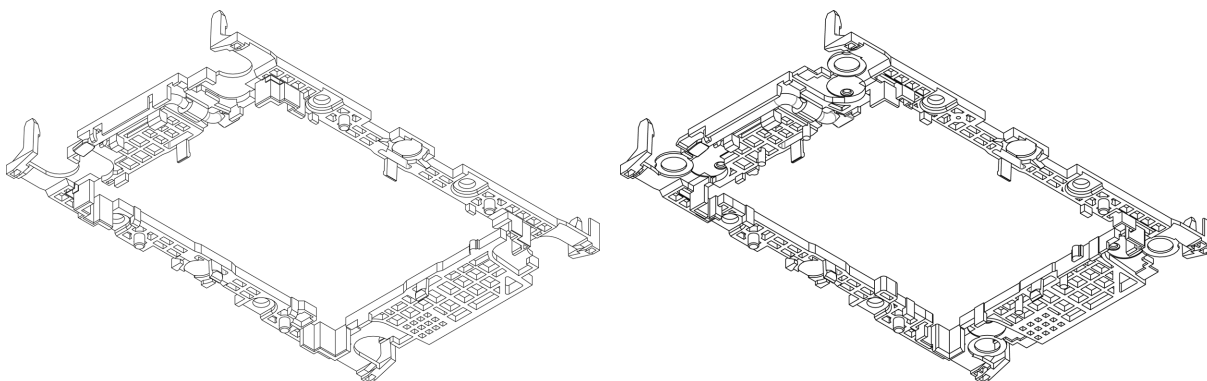

Figure 2-16. Carrier (SP XCC E2A left, SP HCC/LCC E2B right)

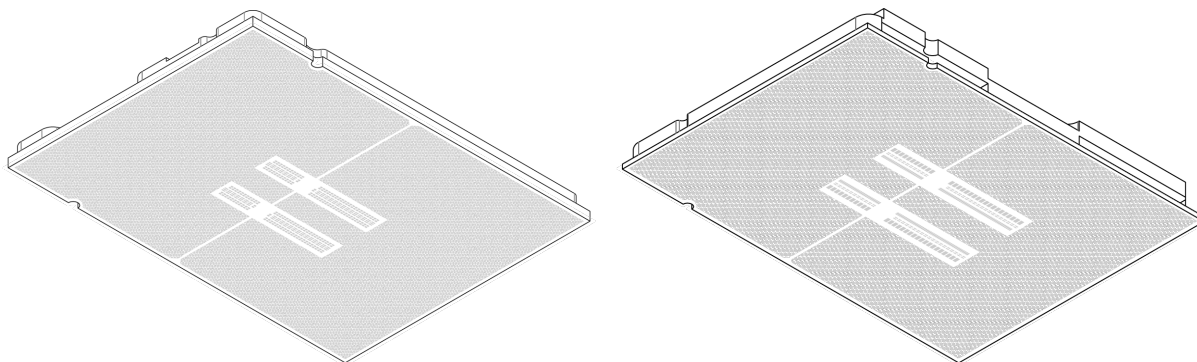

Figure 2-17. Processor (SP XCC E2A left, SP HCC/LCC E2B right)

Installing the Processor

To install the processor, follow the steps below:

1. Before installation, make sure the lever on the processor carrier is pressed down as shown below.

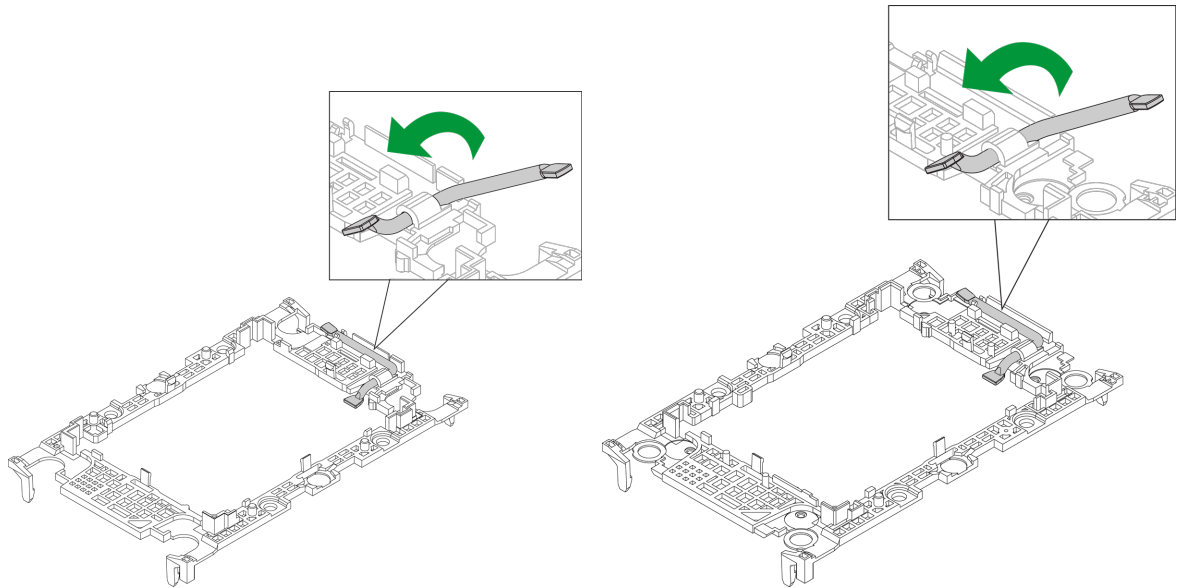

Figure 2-18. Carrier Lever (SP XCC left, SP HCC/LCC right)

2. Hold the processor with the LGA lands (gold contacts) facing up. Locate the small, gold triangle in the corner of the processor and the corresponding hollowed triangle on the processor carrier. These triangles indicate pin 1.

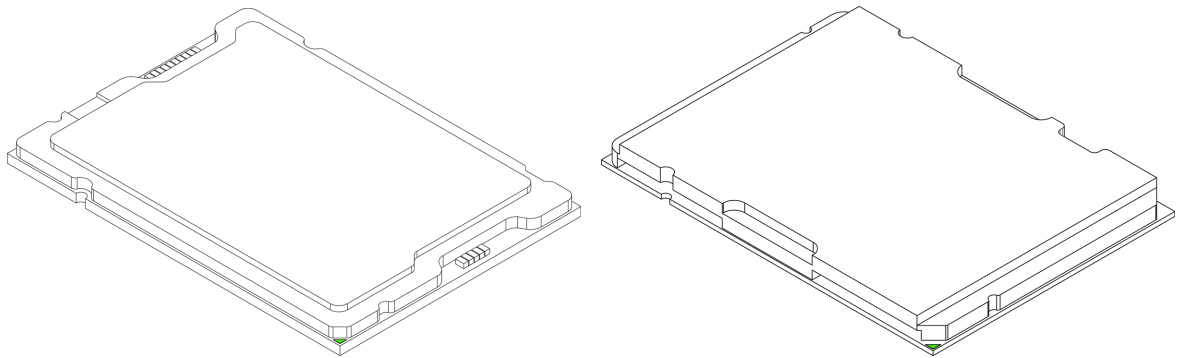

Figure 2-19. Processor (SP XCC E2A left, SP HCC/LCC E2B right)

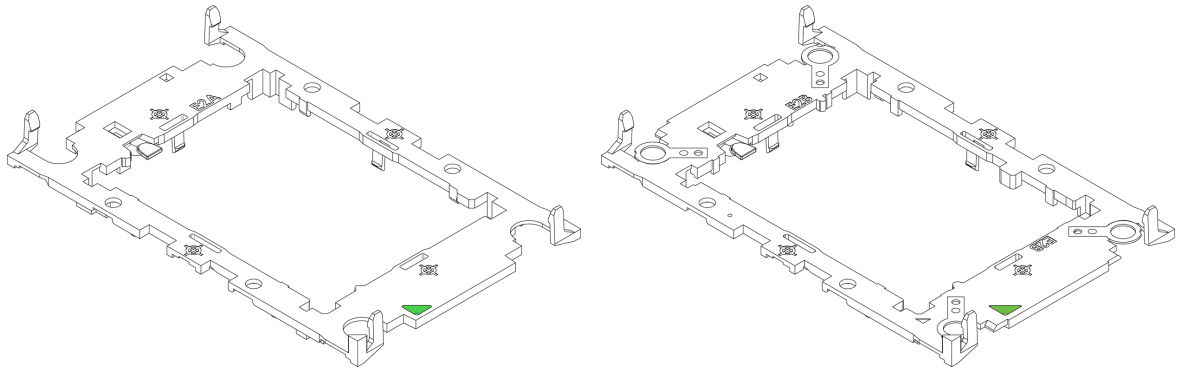

Figure 2-20. Carrier (SP XCC E2A left, SP HCC/LCC E2B right)

3. Use the triangles as a guide to carefully align and place one end of the processor into the latch marked A, and place the other end of the processor into the latch marked B as shown below.

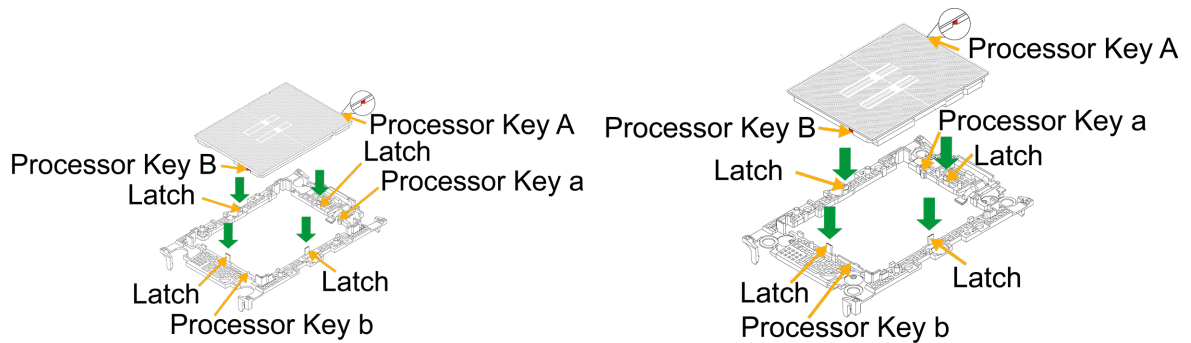

Figure 2-21. Keys and Latches Locations (SP XCC E2A left, SP HCC/LCC E2B right)

4. Examine all corners to ensure that the processor is firmly attached to the carrier.

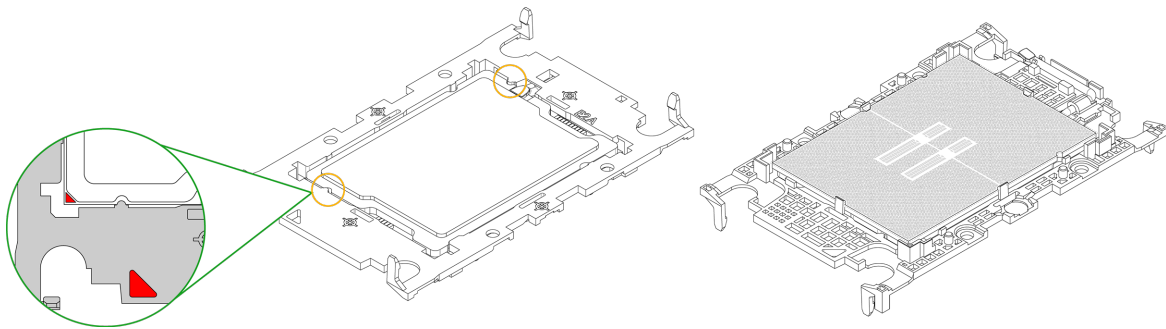

Figure 2-22. SP XCC E2A Keys and Latches

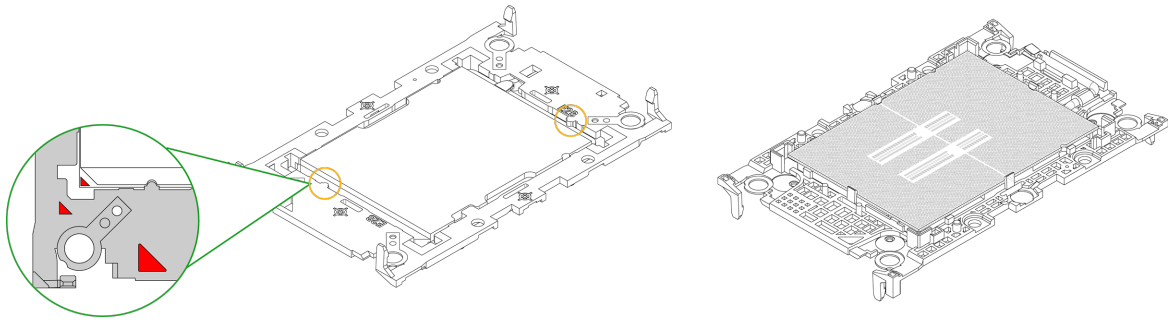

Figure 2-23. SP HCC/LCC E2B Keys and Latches Together

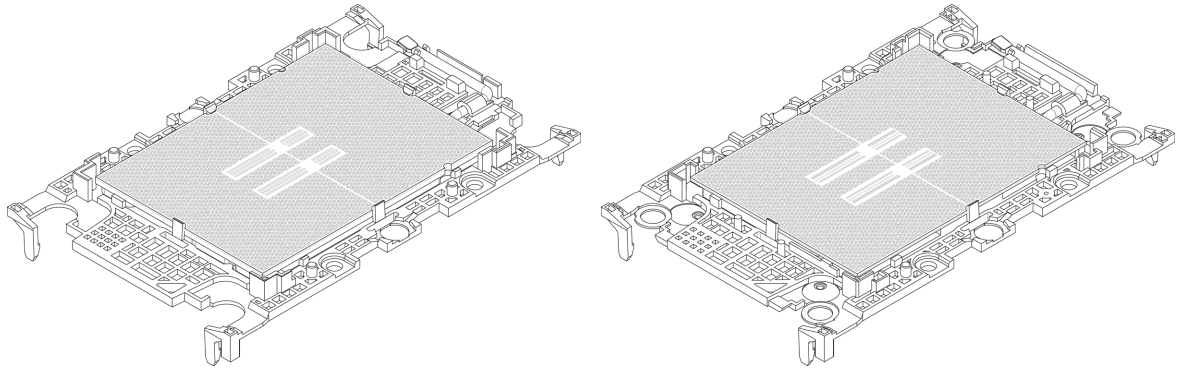

Figure 2-24. Carrier Assembly Completed (SP XCC E2A left, SP HCC/LCC E2B right)

Assembling the Processor Heatsink Module

After installing the processor into the carrier, mount it onto the heatsink to create the processor heatsink module (PHM):

1. Loosen the Torx screw from the heatsink.

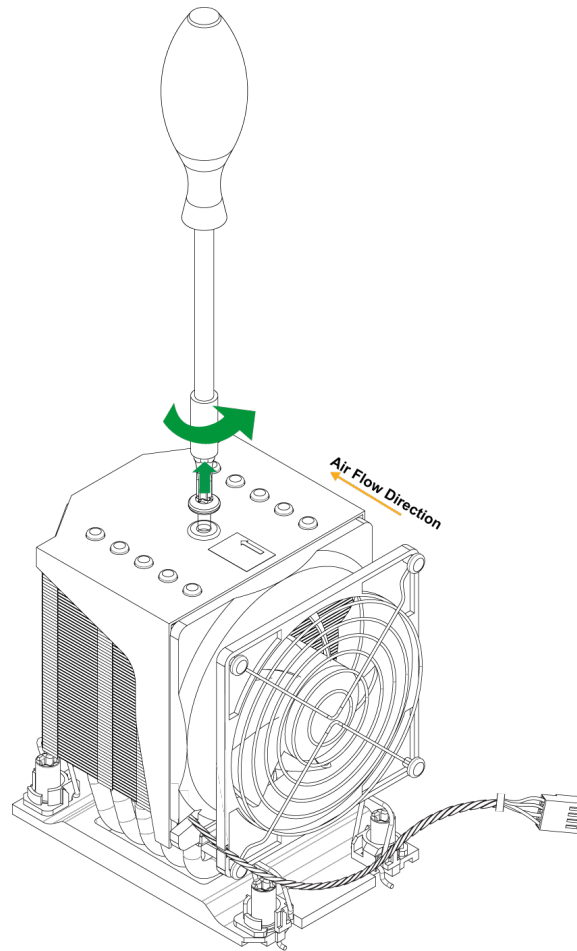

Figure 2-25. Loosening the Screw

2. Gently pull the heatsink fan upward to detach it from the heatsink.

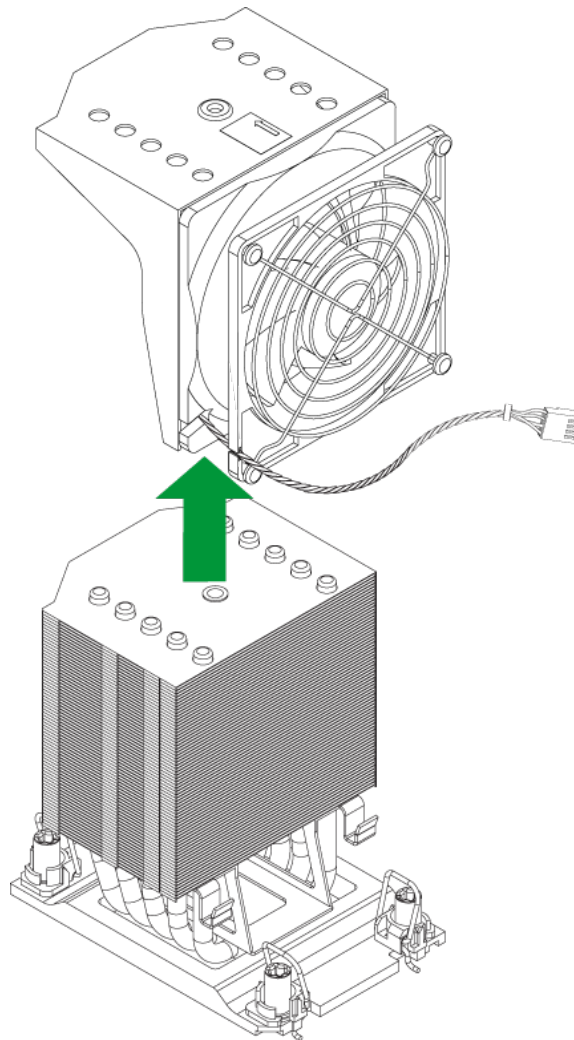

Figure 2-26. Heatsink Fan Detached

3. Note the label on top of the heatsink, which marks the airflow direction. Turn the heatsink over and orient the heatsink so the airflow arrow is pointing towards the triangle on the processor.
4. If this is a new heatsink, the thermal grease has been pre-applied. Otherwise, apply the proper amount of thermal grease.
5. Hold the processor carrier so the processor's gold contacts are facing up, then align the holes of the processor carrier with the holes on the heatsink. Press the processor carrier down until it snaps into place. The plastic clips of the processor carrier will lock at the four corners.

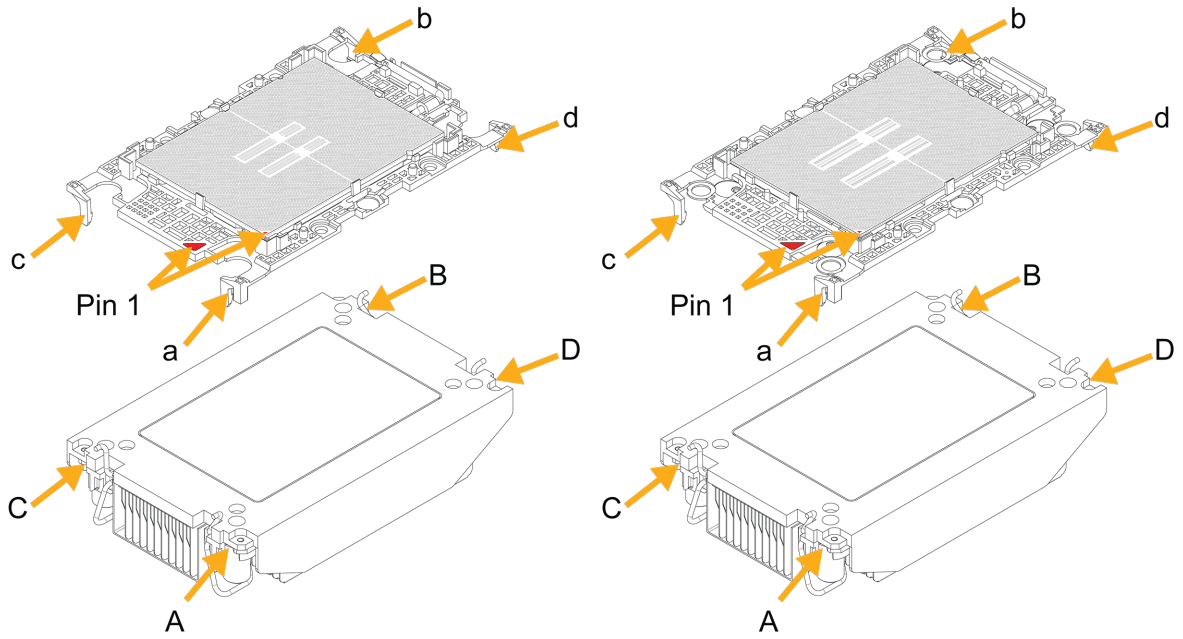

Figure 2-27. Carrier with 1U Heatsink (SP XCC left, SP HCC/LCC right)

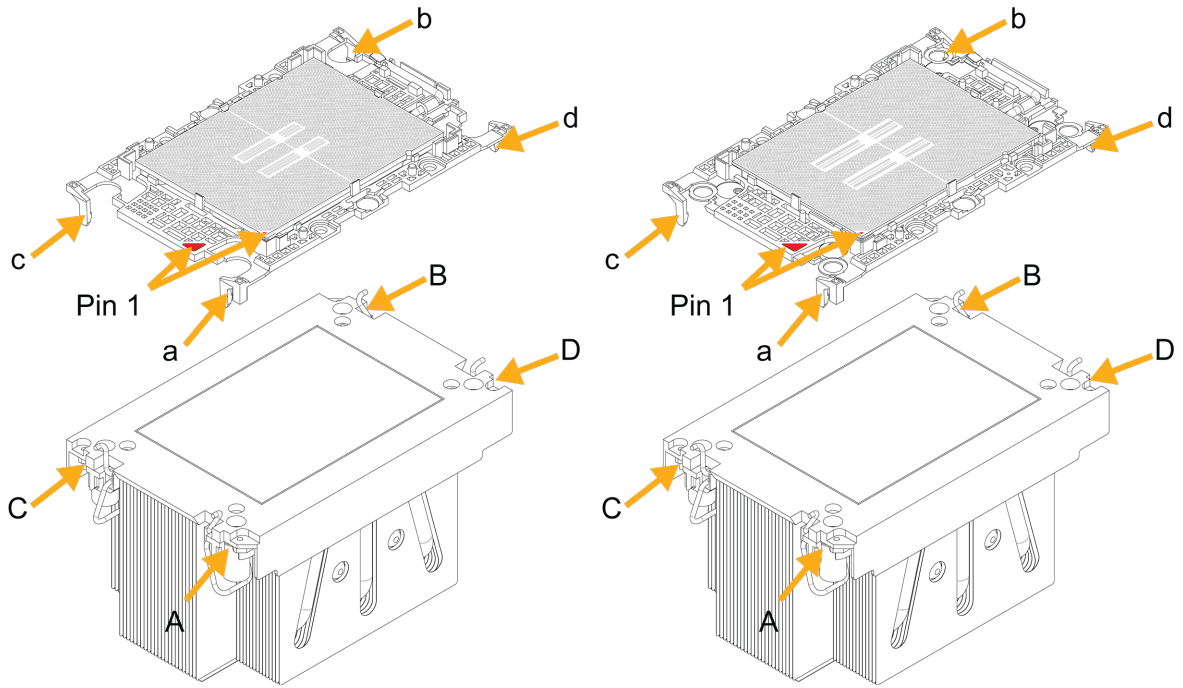

Figure 2-28. Carrier with 2U Heatsink (SP XCC left, SP HCC/LCC right)

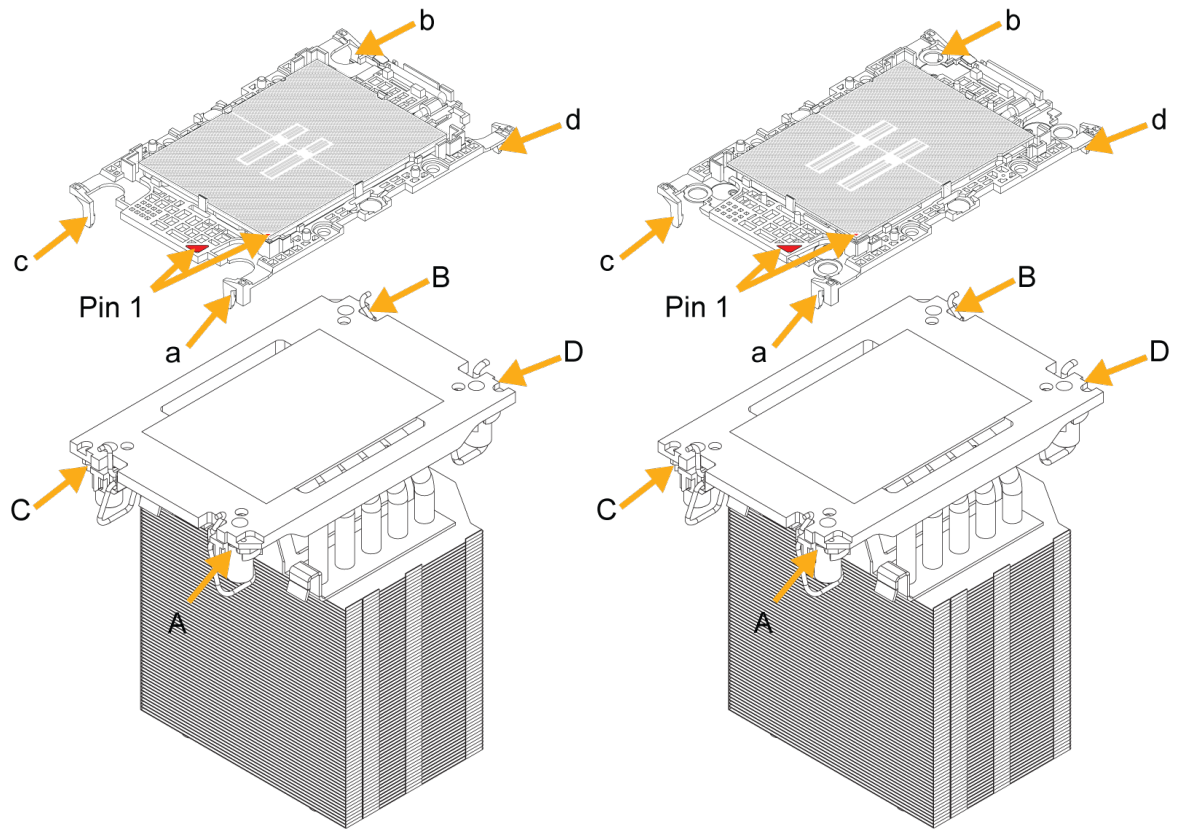

Figure 2-29. Carrier with 4U Heatsink (SP XCC left, SP HCC/LCC right)

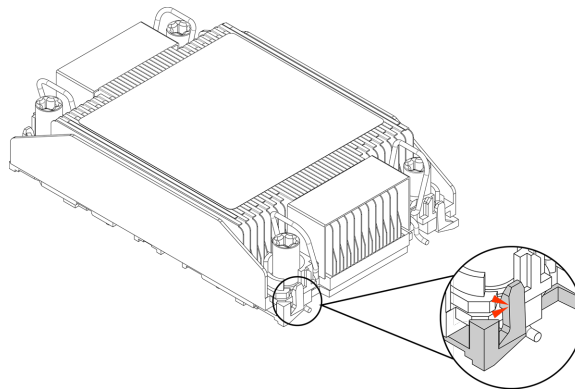

Figure 2-30. PHM Plastic Clips Locked(1U)

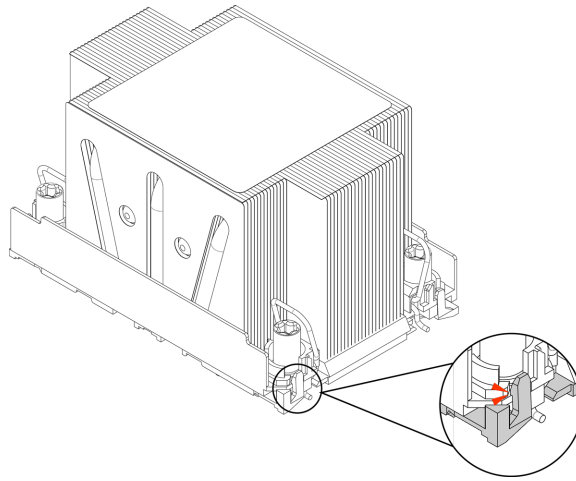

Figure 2-31. PHM Plastic Clips Locked (2U)

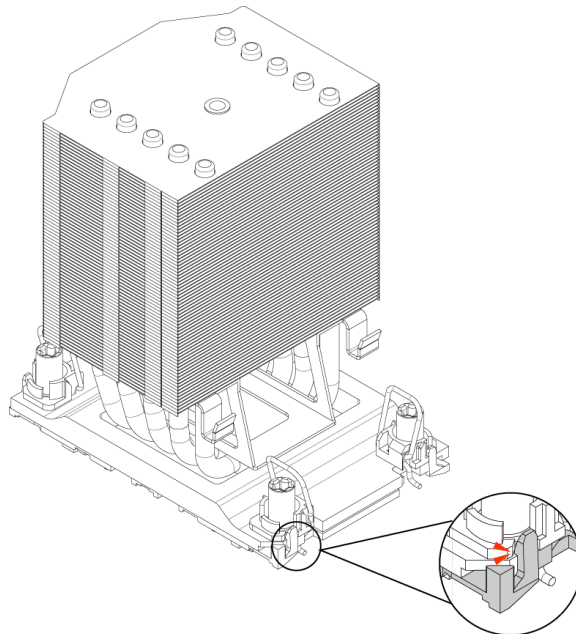

Figure 2-32. PHM Plastic Clips Locked (4U)

6. Examine all corners to ensure that the plastic clips on the processor carrier are firmly attached to the heatsink.

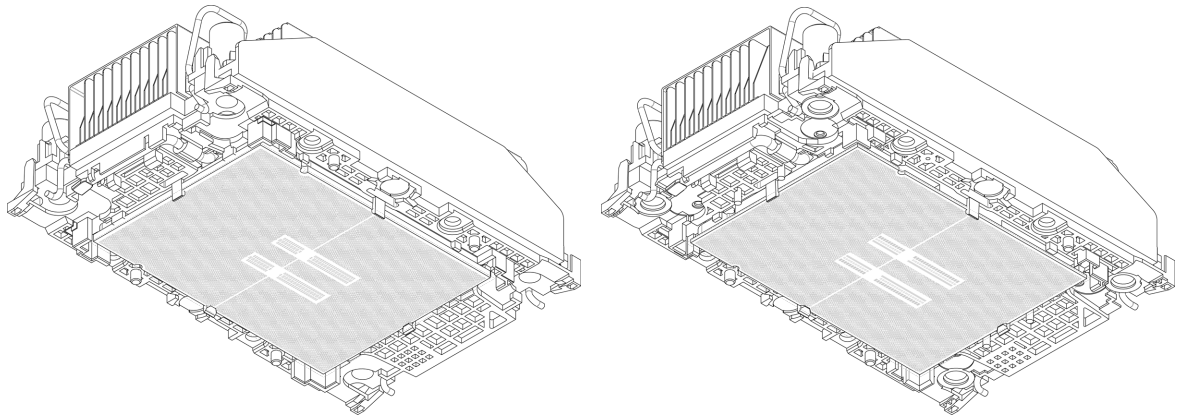

Figure 2-33. 1U PHM Completed (SP XCC left, SP HCC/LCC right)

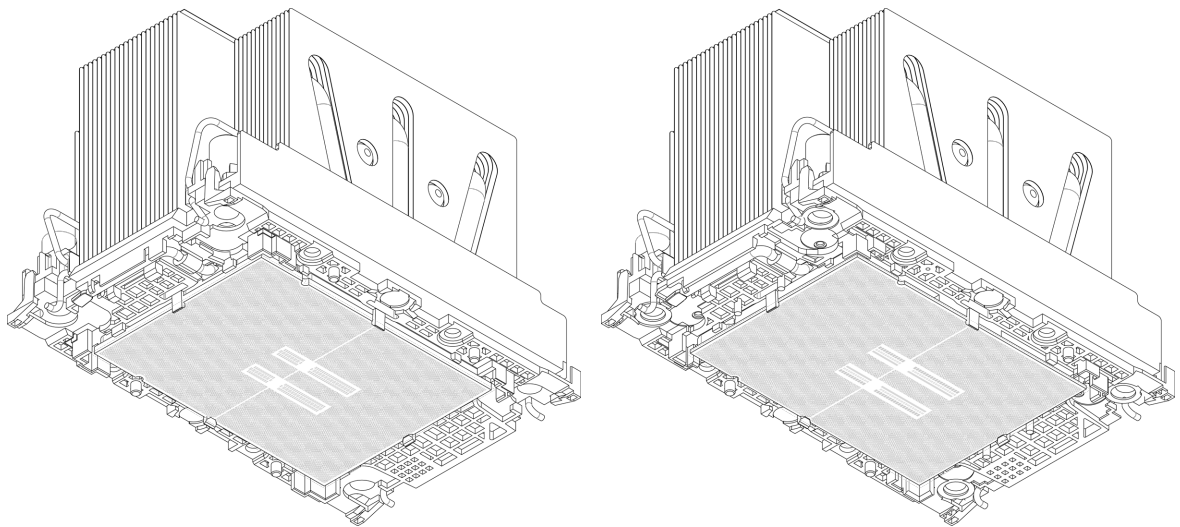

Figure 2-34. 2U PHM Completed (SP XCC left, SP HCC/LCC right)

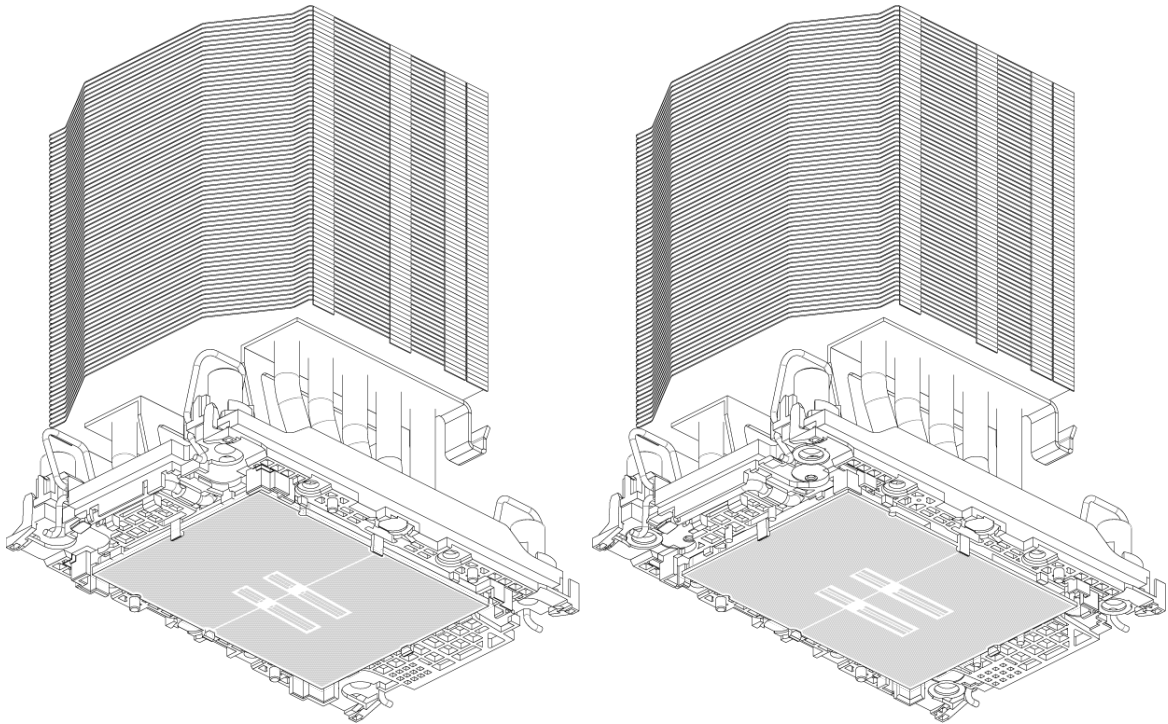

Figure 2-35. 4U PHM Completed (SP XCC left, SP HCC/LCC right)

Preparing the Processor Socket for Installation

This motherboard comes with a plastic protective cover installed on the processor socket. Remove it from the socket to install the Processor Heatsink Module (PHM). Gently pull up one corner of the plastic protective cover to remove it.

1. Press the tabs inward.

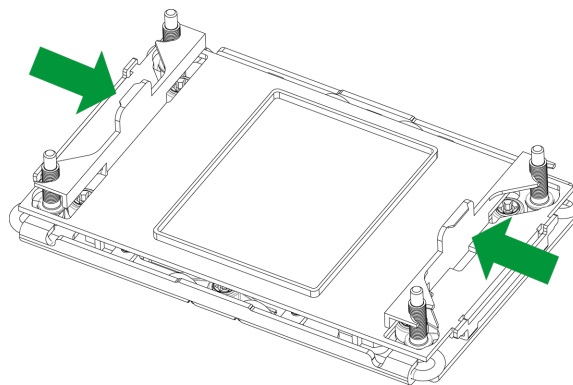

Figure 2-36. Processor Socket with Plastic Protective Cover

2. Pull up the protective cover from the socket.

Note: Do not touch or bend the socket pins.

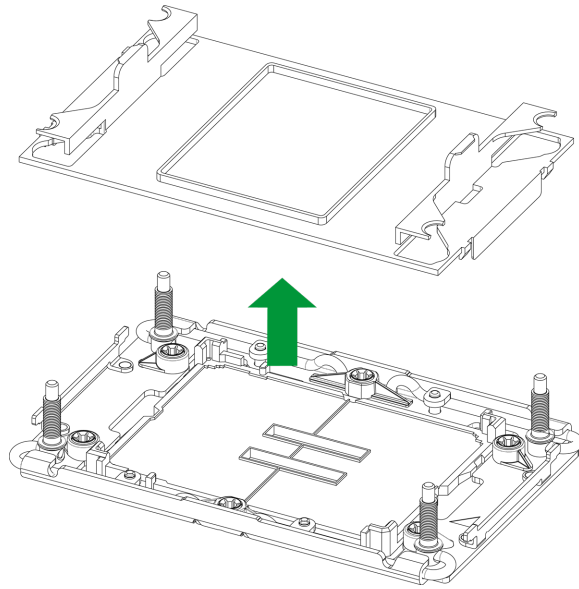
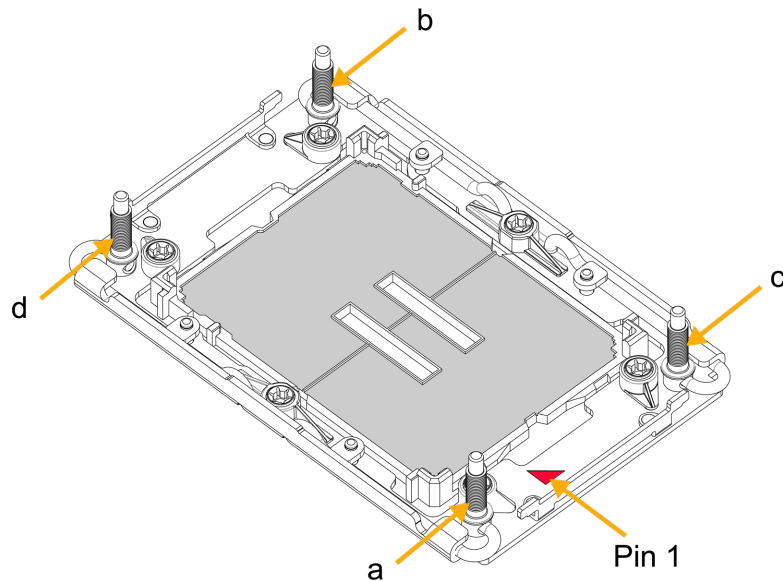

Figure 2-37. Plastic Protective Cover Removed

Preparing to Install the PHM into the Processor Socket

After assembling the Processor Heatsink Module (PHM), you are ready to install it into the processor socket. To ensure the proper installation, follow the procedures below:

1. Locate four threaded fasteners (marked a, b, c, and d) on the processor socket.



a, b, c, d: Threaded Fasteners

Figure 2-38. Threaded Fasteners

2. Locate four PEEK nuts (marked A, B, C, and D) and four rotating wires (marked 1, 2, 3, and 4) on the heatsink.

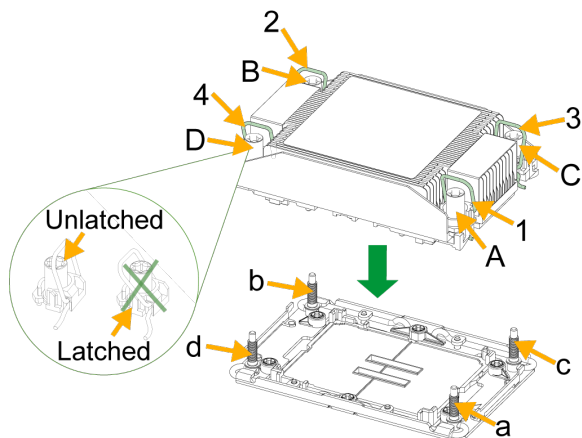

Figure 2-39. PEEK Nuts and Rotating Wires (1U)

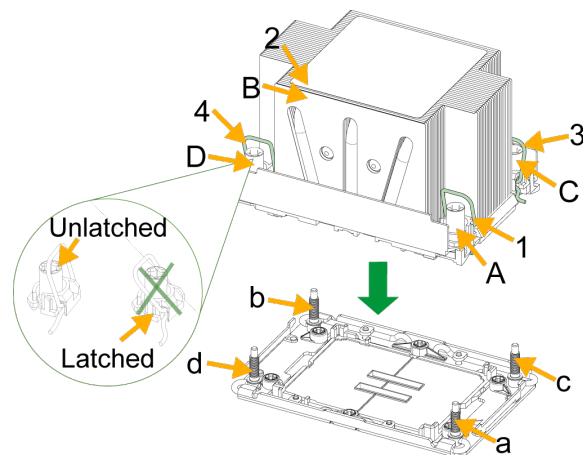

Figure 2-40. PEEK Nuts and Rotating Wires (2U)

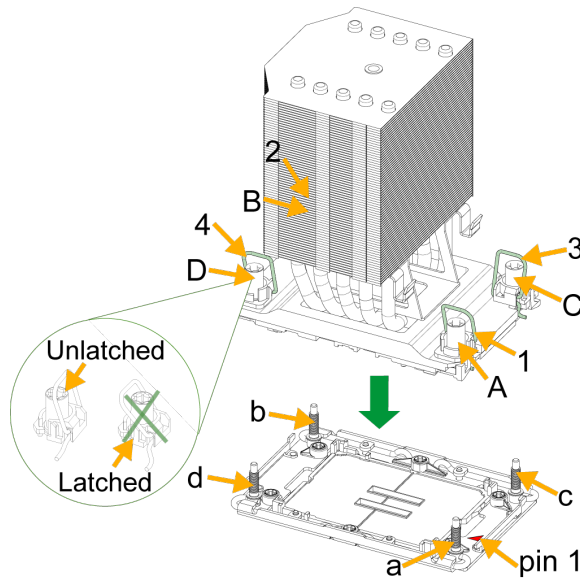

Figure 2-41. PEEK Nuts and Rotating Wires (4U)

3. Check the rotating wires (marked 1, 2, 3, and 4) to make sure that they are at unlatched positions before installing the PHM into the processor socket.

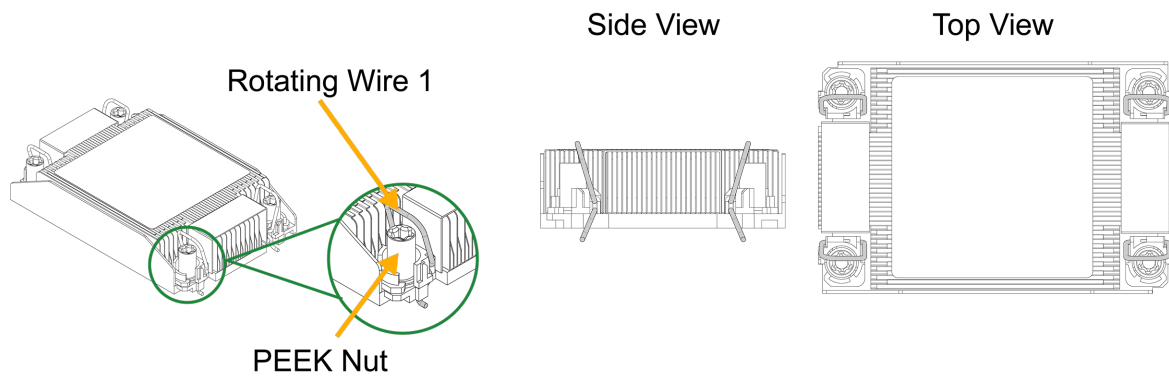

Figure 2-42. 1U Unlatched Positions

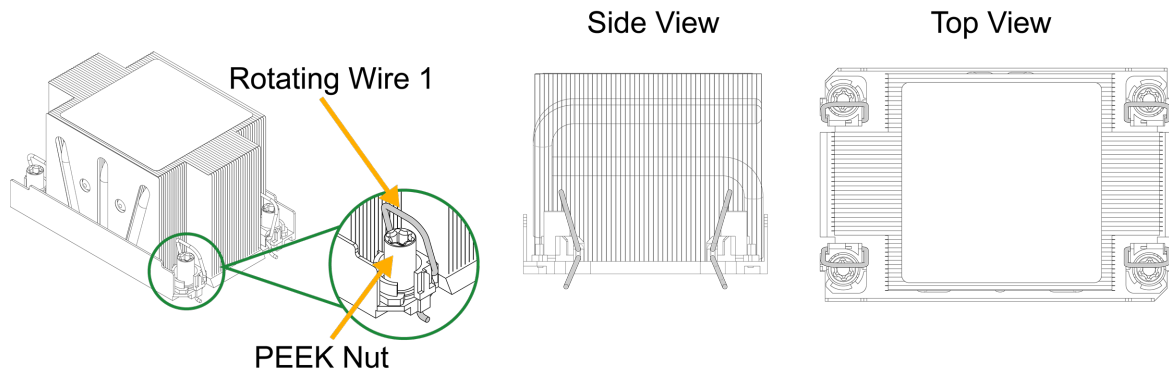

Figure 2-43. 2U Unlatched Positions

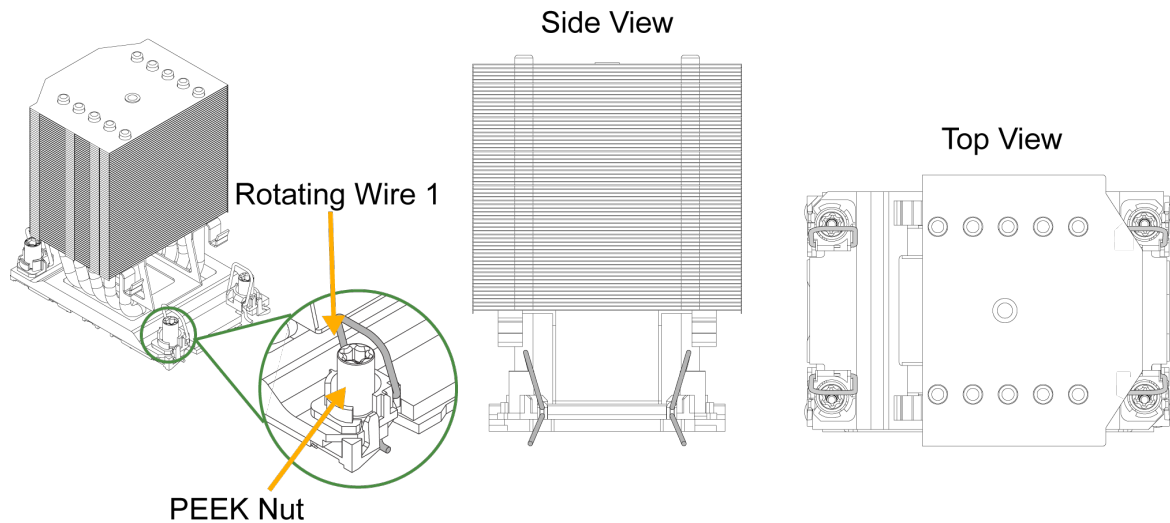
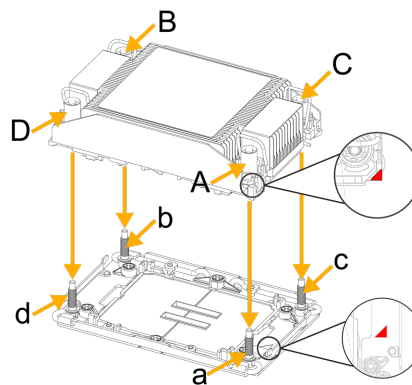

Figure 2-44. 4U Unlatched Positions

Installing the Processor Heatsink Module

1. Align pin 1 of the PHM with the printed triangle on the processor socket.
2. Make sure all four PEEK nuts of the heatsink (marked A, B, C, and D) are aligned with the threaded fasteners (marked a, b, c, and d), then gently place the heatsink on top of the processor socket.

A, B, C, D:
PEEK Nut on the Heatsink



a, b, c, d:
Threaded Fastener on the processor socket

Figure 2-45. Aligning the Heatsink with the Socket (1U)

A, B, C, D:
PEEK Nut on the Heatsink

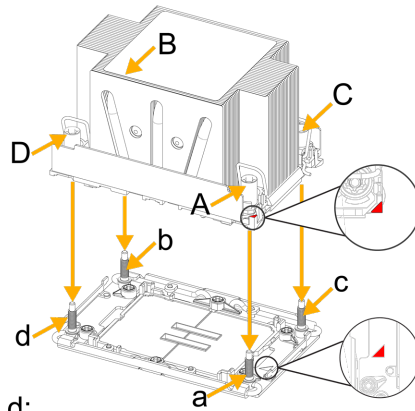

a, b, c, d:
Threaded Fastener on the processor socket

Figure 2-46. Aligning the Heatsink with the Socket (2U)

A, B, C, D:
PEEK Nut on the Heatsink

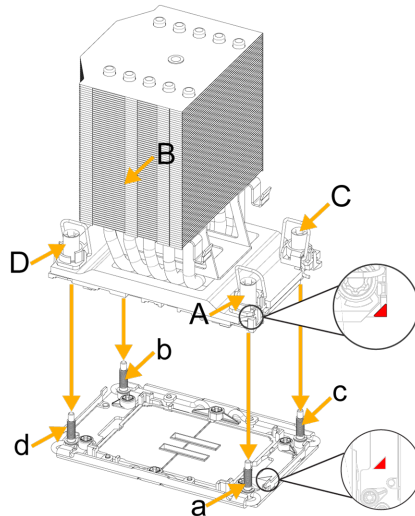

a, b, c, d:
Threaded Fastener on the processor socket

Figure 2-47. Aligning the Heatsink with the Socket (4U)

3. Press all four rotating wires outwards and make sure that the heatsink is securely latched into the processor socket.

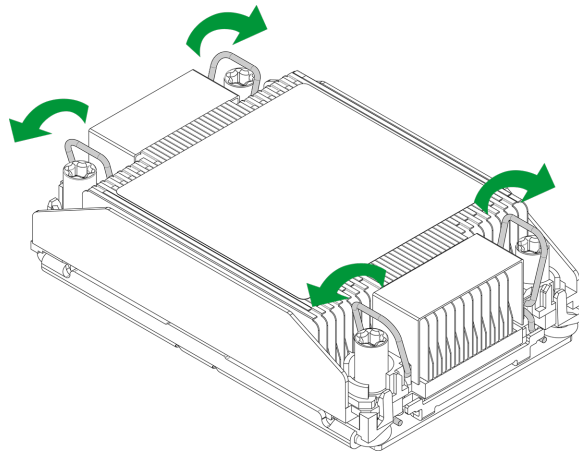

Figure 2-48. Latching the PHM (1U)

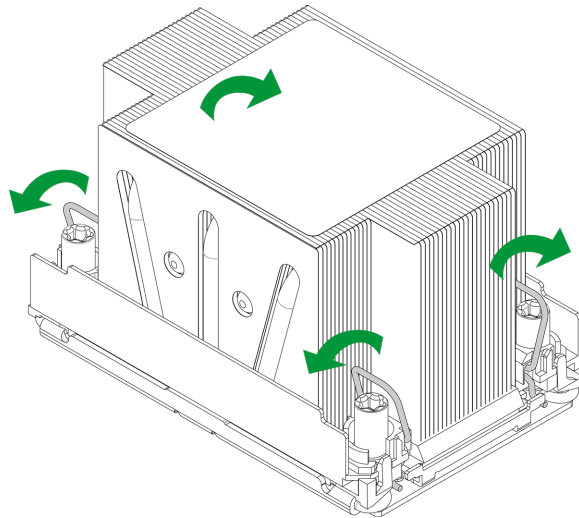

Figure 2-49. Latching the PHM (2U)

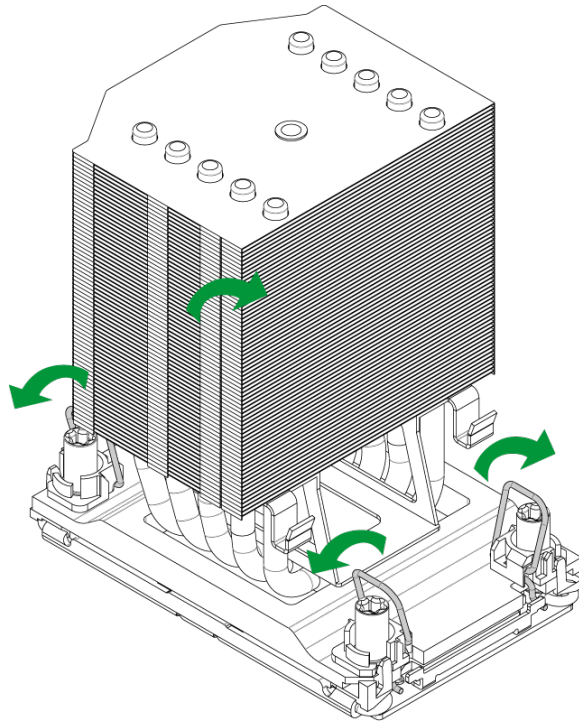

Figure 2-50. Latching the PHM (4U)

4. With a T30 bit torque driver set to a force of 8.0 lbf-in (0.904 N-m), gradually tighten the four screws to ensure even pressure. You can start with any screw, but make sure to tighten the screws in a diagonal pattern.

Important: Do not use a force greater than 8.0 lbf-in (0.904 N-m). Exceeding this force may over-torque the screw, causing damage to the processor, heatsink, and screw.

5. Examine all corners to ensure that the PHM is firmly attached to the socket.

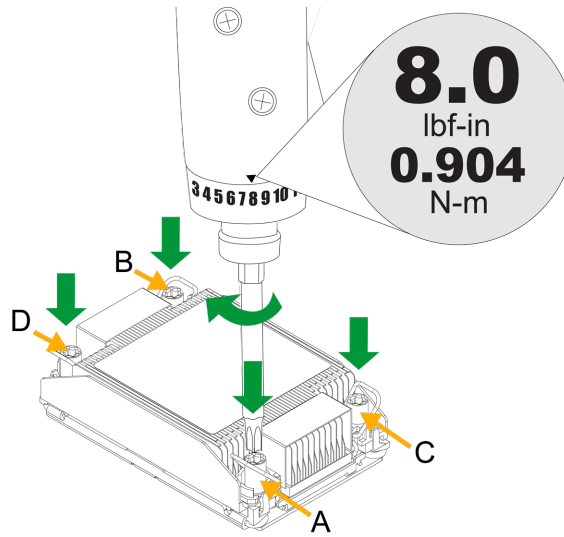

Figure 2-51. Installing the PHM with a Torque Driver (1U)

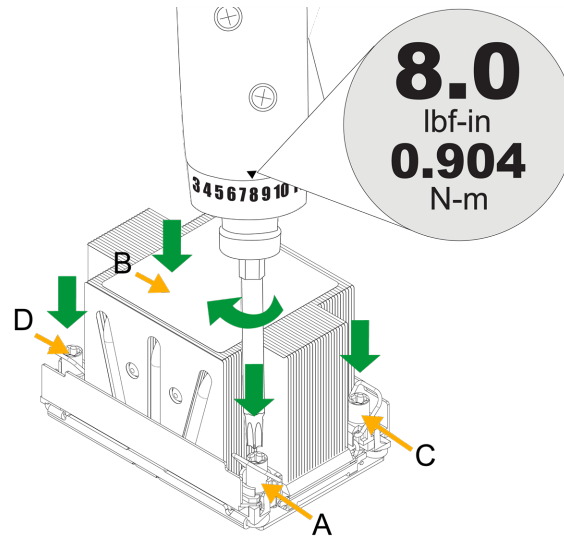

Figure 2-52. Installing the PHM with a Torque Driver (2U)

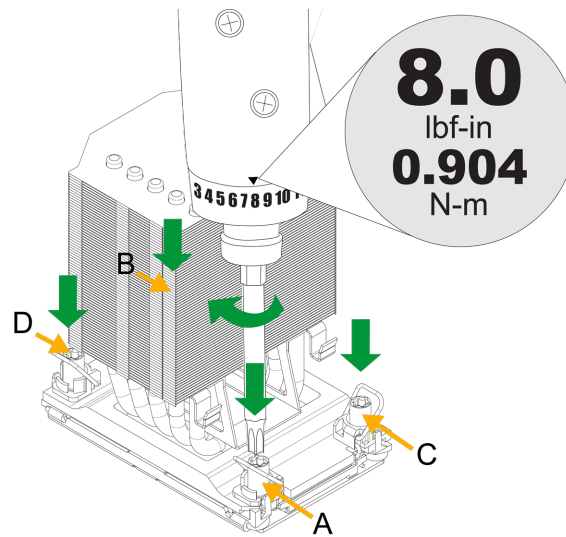

Figure 2-53. Installing the PHM with a Torque Driver (4U)

6. Align the aluminum fan shroud against the top of the 4U heatsink. The fan shroud was designed to match perfectly with the top of the heatsink in terms of geometric shape.

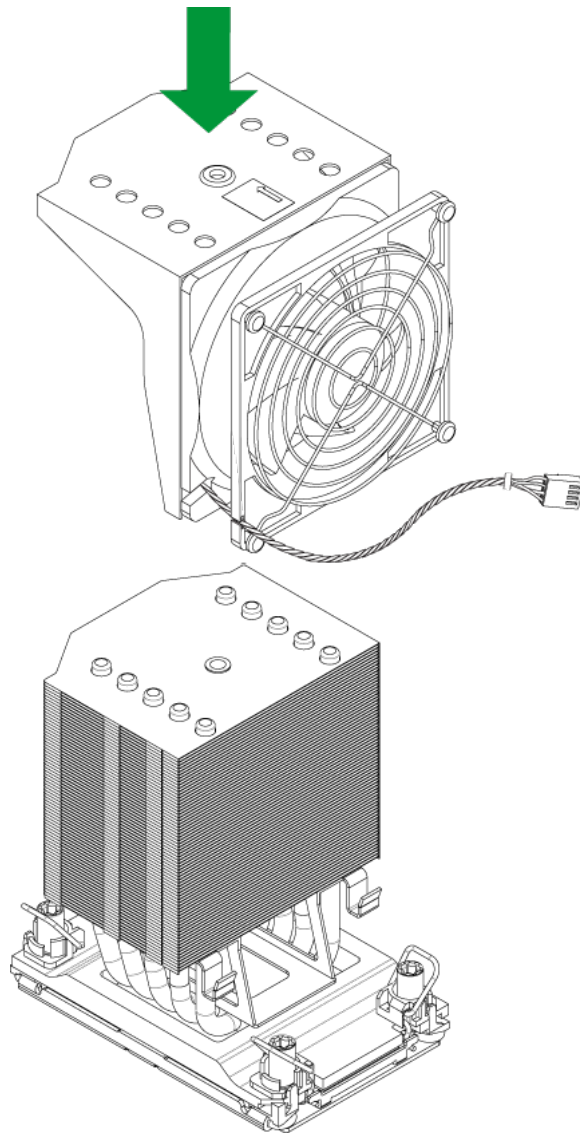

Figure 2-54. Aligning the Heatsink Fan

7. When the fan shroud and the top of the heatsink are properly aligned, gently push the fan onto the heatsink until the bottom of the fan properly rests on the two hooks of the heatsink.

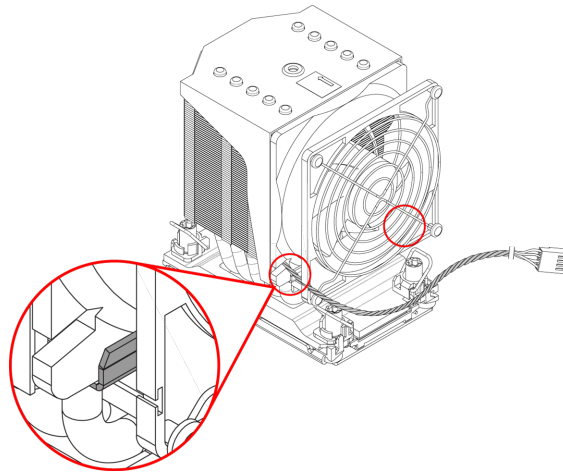

Figure 2-55. Installing the Heatsink Fan

8. Insert the Torx screw into the screw hole on top of the heatsink and turn it clockwise to tighten the screw.

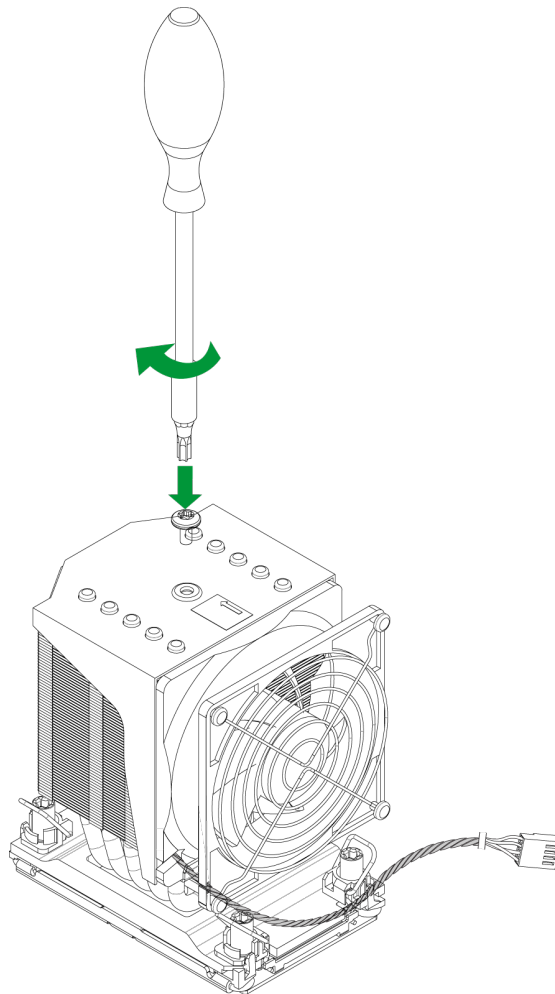

Figure 2-56. Tightening the Screw

9. Connect the fan power connector to a 4-pin fan header on the motherboard.

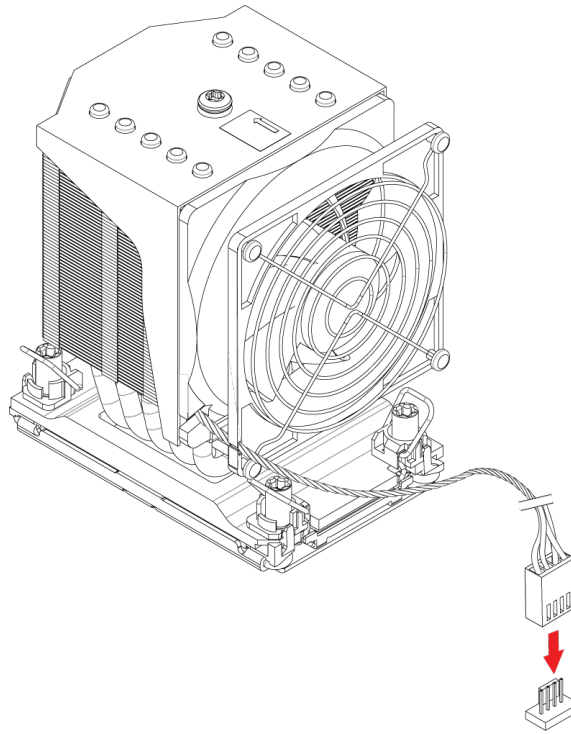

Figure 2-57. Connecting the Fan Power

Removing the Processor Heatsink Module

Before removing the processor heatsink module (PHM) from the motherboard, shut down the system and then unplug the AC power cord from all power supplies.

Then follow the steps below:

1. Loosen the Torx screw from the heatsink. Unplug the fan power connector from the fan header.

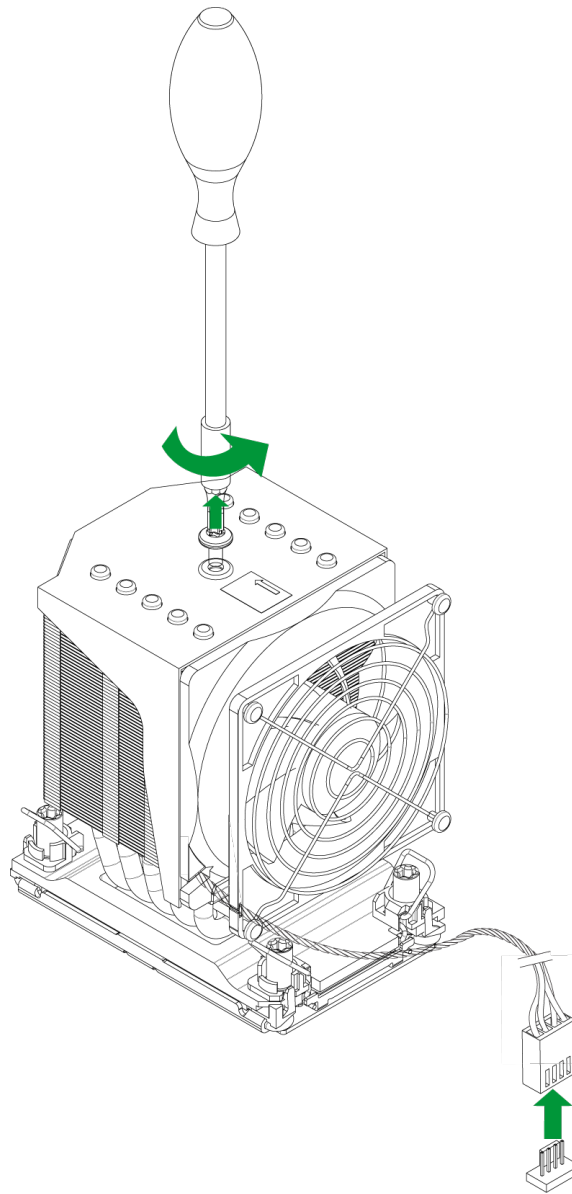

Figure 2-58. Loosening the Screw and Unplugging the Fan Power Header

2. Gently pull the heatsink fan upward to detach it from the heatsink.

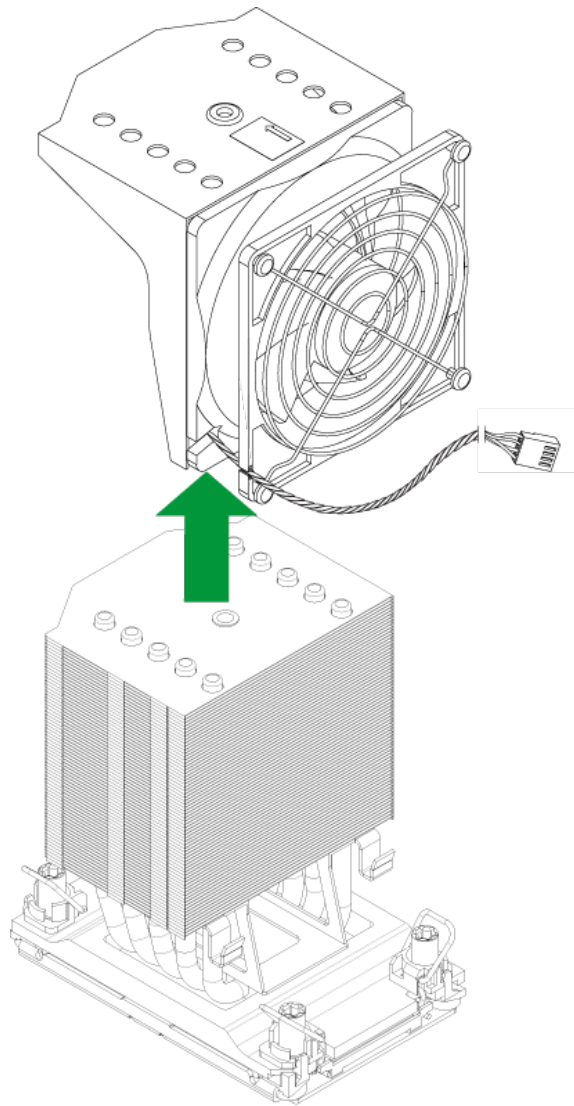

Figure 2-59. Removing the Fan

3. Use a screwdriver to loosen the four screws. You can start with any screw, but make sure to loosen the screws in a diagonal pattern.

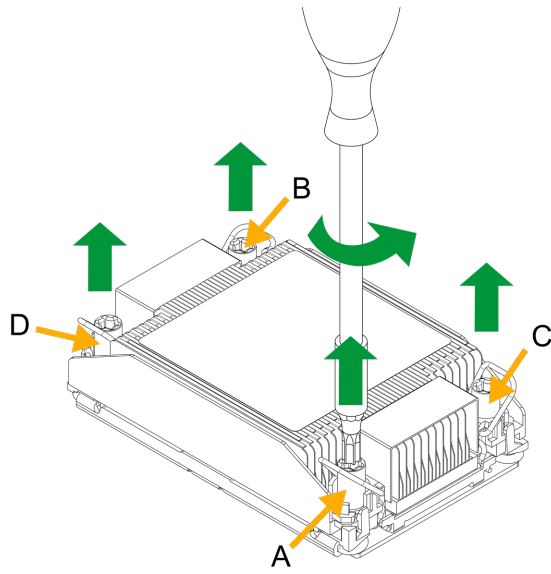

Figure 2-60. Loosening the Screws (1U)

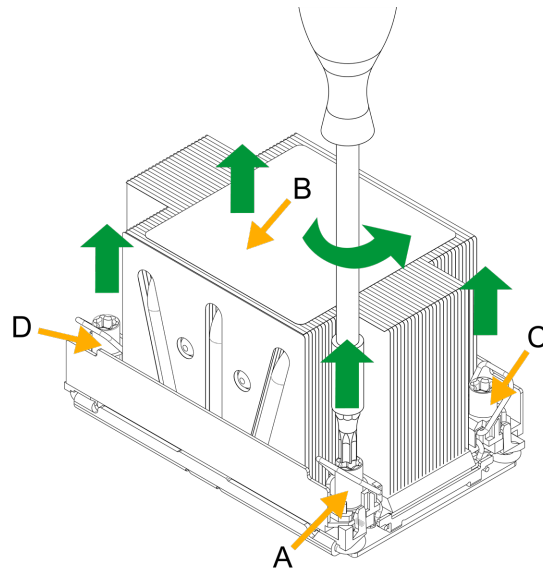

Figure 2-61. Loosening the Screws (2U)

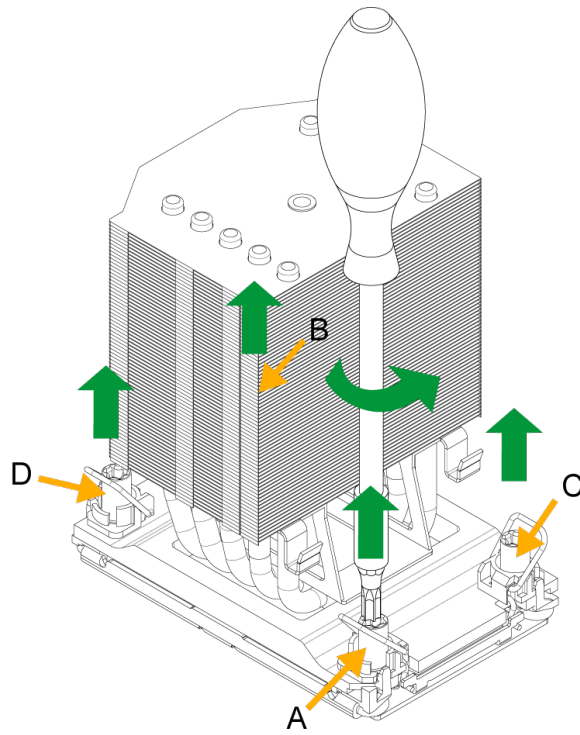

Figure 2-62. Loosening the Screws (4U)

4. Press the four rotating wires inwards to unlatch the PHM from the socket.

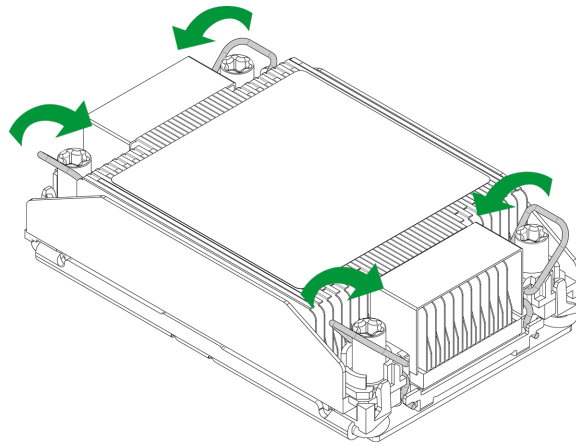

Figure 2-63. Unlatching the PHM (1U)

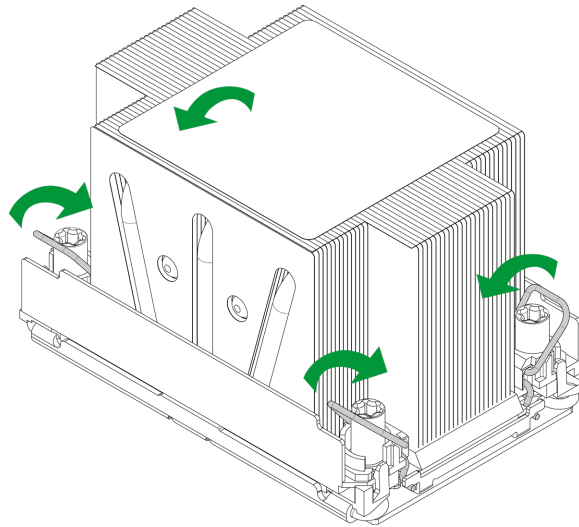

Figure 2-64. Unlatching the PHM (2U)

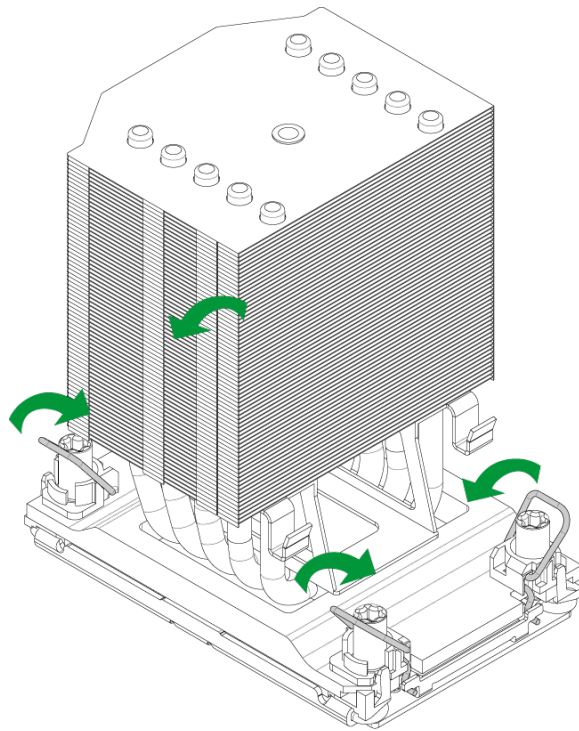

Figure 2-65. Unlatching the PHM (4U)

5. Gently lift the PHM upwards to remove it from the socket.

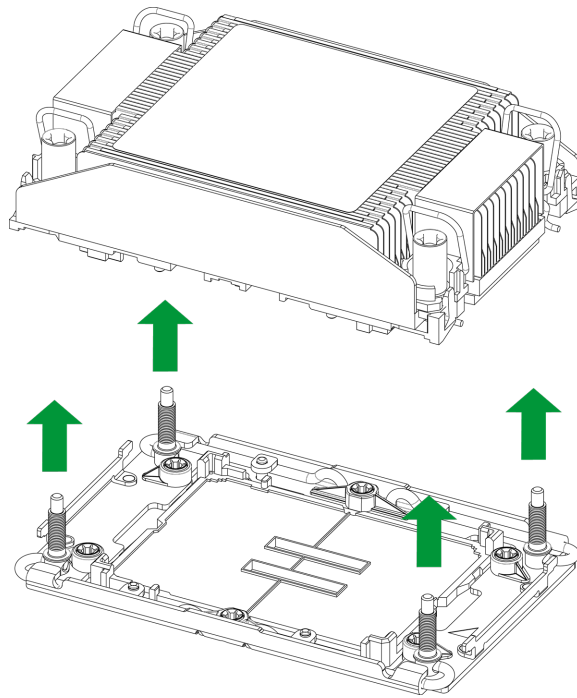

Figure 2-66. Removing the PHM from the Socket (1U)

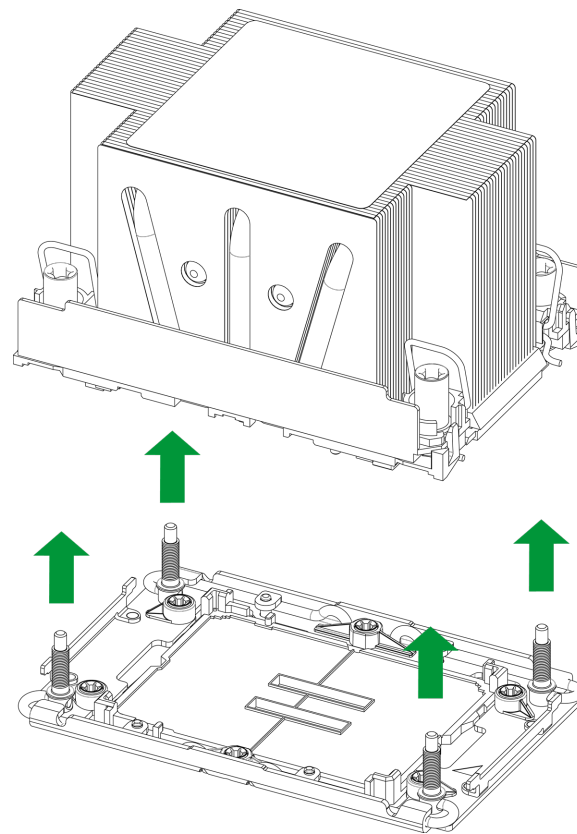

Figure 2-67. Removing the PHM from the Socket (2U)

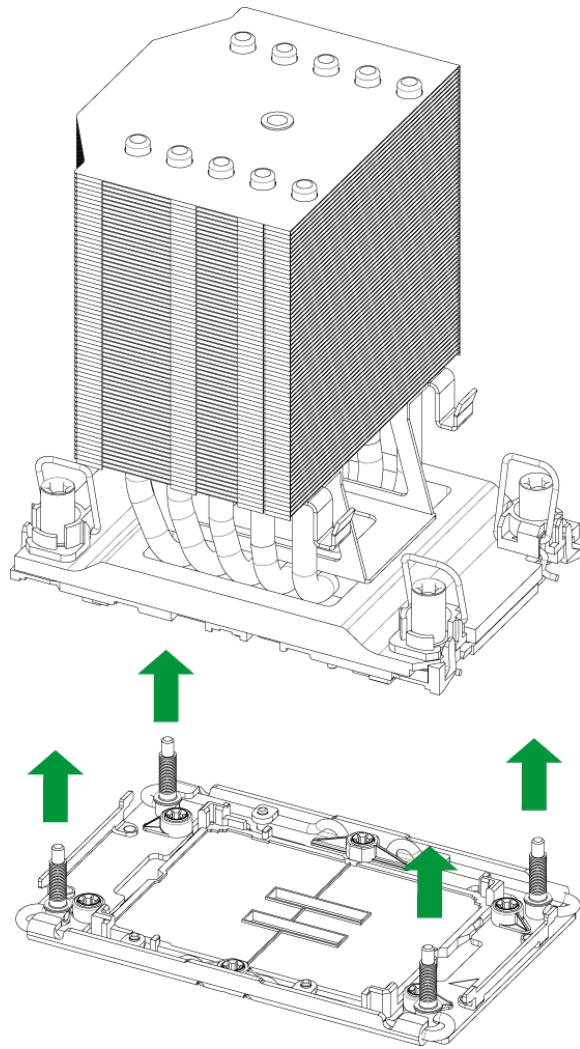

Figure 2-68. Removing the PHM from the Socket (4U)

6. To remove the processor from the heatsink, gently lift the lever from the processor carrier.

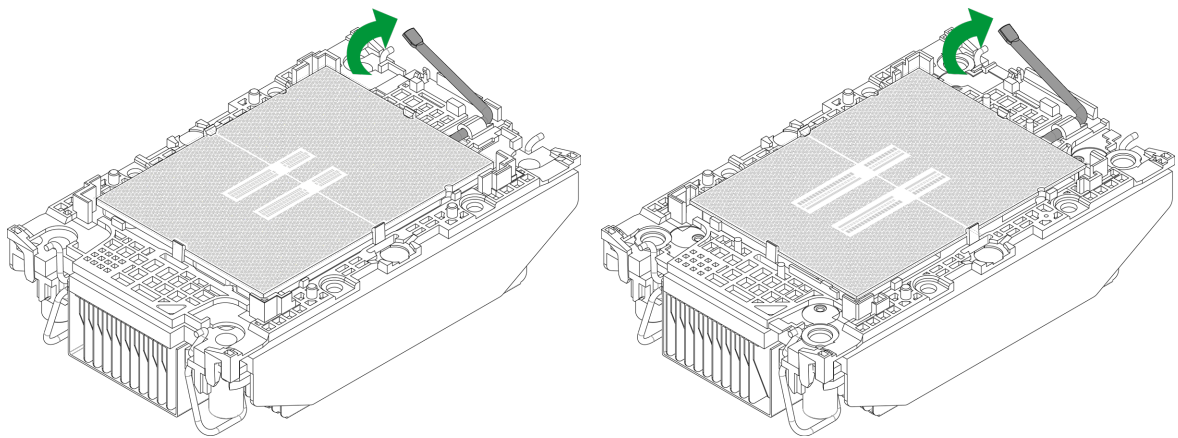

Figure 2-69. Carrier with 1U Heatsink (SP XCC left, SP HCC/LCC right)

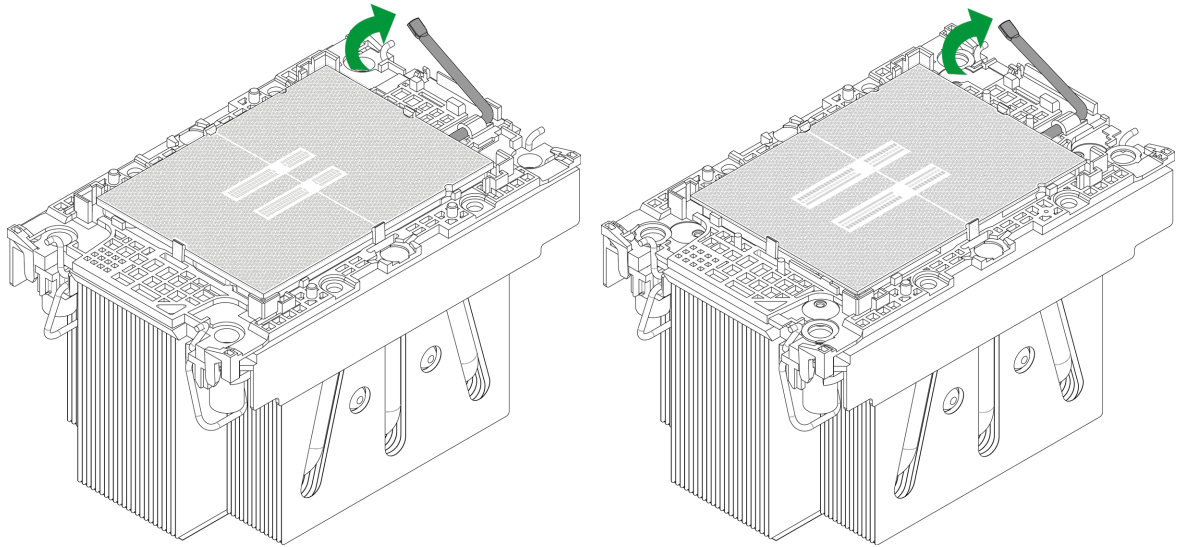

Figure 2-70. Carrier with 2U Heatsink (SP XCC left, SP HCC/LCC right)

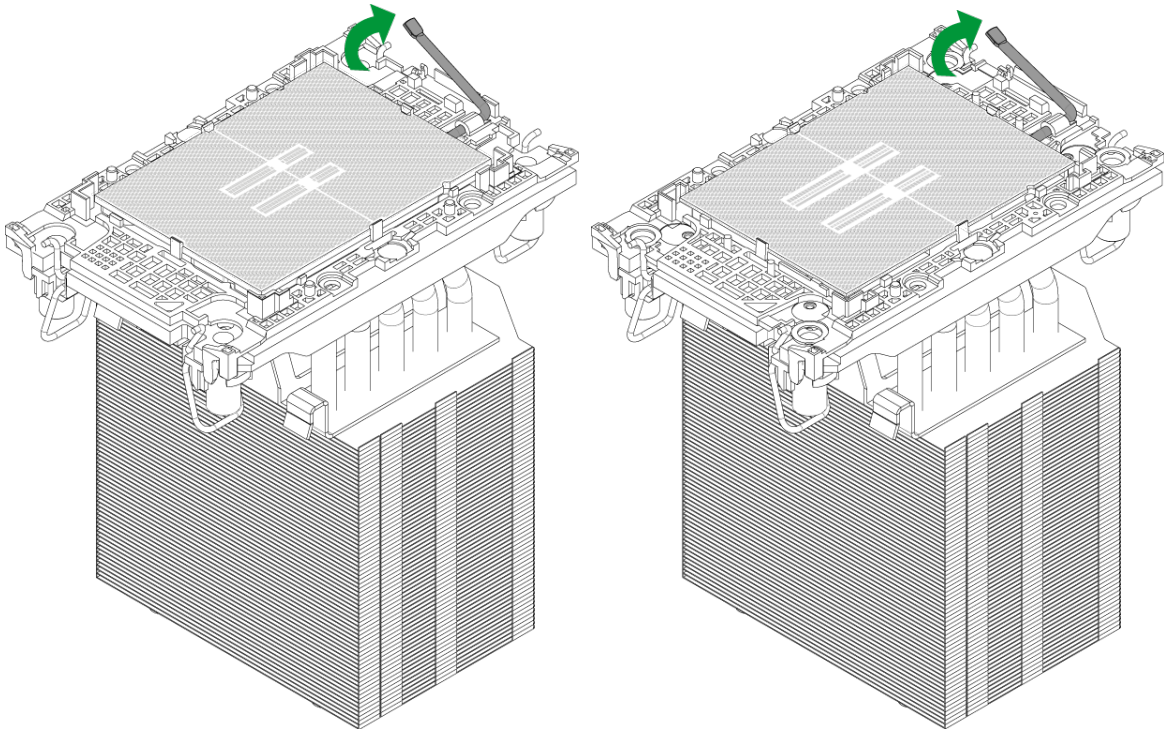

Figure 2-71. Carrier with 4U Heatsink (SP XCC left, SP HCC/LCC right)

7. To remove the processor, move the lever to its unlocked position and gently remove the processor.

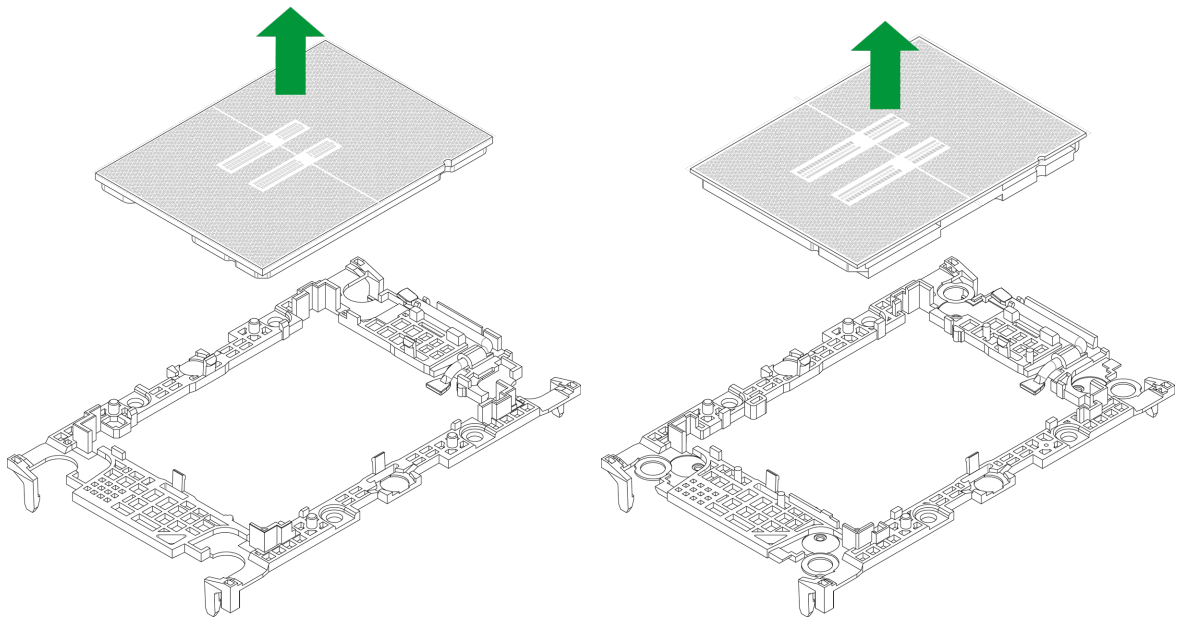

Figure 2-72. Removing the Processor (SP XCC left, SP HCC/LCC right)

2.4 Memory Support and Installation

Important: To prevent any damage, exercise extreme care when installing or removing memory modules.

Note: Check the Supermicro website for recommended memory modules.

Memory Support

The X14DBM-SP motherboard supports up to 4 TB of ECC DDR5 RDIMM/RDIMM 3DS memory with speeds of up to 6400 MT/s (1DPC) or up to 5200 MT/s (2DPC) in DIMM slots. In addition, MRDIMM DDR5 memory with speeds up to 8000 MT/s (1DPC or 2 slots per channel) is also supported.

To enhance memory performance and ensure system stability, do not mix memory modules of different speeds, different sizes, and different types in your server.

Note: Memory speed/capacity support depends on the processors used in the system.

Intel Xeon 6700-Series Processors with E-Cores

DDR5-6400 Memory Support for Intel® Xeon® 6700-Series Processors with E-Cores									
Type	Ranks Per DIMM, Data Width (Stack)	DIMM Capacity (GB)						Speed (MT/s); Voltage (V); Slots per Channel (SPC) and DIMMs per Channel (DPC)	
		DRAM Density						1DPC/2SPC	2DPC/2SPC
		16 Gb		24 Gb		32 Gb			
		1DPC	2DPC	1DPC	2DPC	1DPC	2DPC		
RDIMM	1Rx4	32 GB	-	-	-	-	-	6400, 6000, 5600, 5200, 4800 (DDR5-6400 rated RDIMMs only)	N/A
	2Rx8	32 GB	-	-	-	-	-		N/A
	2Rx4	64 GB	64 GB	96 GB	96 GB	-	-		5200, 4800 (DDR5-6400 rated RDIMMs only)
	2Rx4	-	-	-	-	128 GB	128 GB		
3DS RDIMM	4Rx4					256 GB	256 GB		

CXL Memory Configuration Support for Intel® Xeon® 6700-Series Processors with E-Cores								
Native DDR5 Memory Per Socket				CXL Memory Per Socket				
Slot 0 DIMM Ranks	Slot 0 DIMM Capacity (GB)	DIMM Type	DRAM Density (Gb)	CXL Memory Channels	CXL Memory Type	CXL Capacity Per Device/Module	CXL Interleave	CXL Mode
2Rx4	64	10x4	16	2+2	DDR5 x8	64 GB	1x4*, 2x2, 4x1	1LM+Vol
2Rx4	64	10x4	16	1+1	DDR5 x16	128 GB	1x2*, 2x1	1LM+Vol
1Rx4	32	10x4	16	2	DDR5 x8	128 GB	1x2*	Intel Flat Memory Mode

Notes:

- The items with an asterisk (*) are the default settings in the BIOS.
- The Intel® Xeon® 6700-series processors with E-cores CXL memory configurations are 1DPC ('Slot 0') only for native DDR5.
- CXL Memory Channel: number of devices per root port, with root ports separated by "+," e.g. 2+2+2+2 = four root ports populated with two devices per root port.
- CXL Interleave: sets x ways, e.g. 2x4 = One set of two modules, interleaved four-way.
- CXL Modes:
 - 1LM + Vol = DDR5 ('1LM') and (volatile) CXL memory visible to SW as separate tiers, separately interleaved.
 - Flat Memory Mode = HW manages data movement between DDR5 and CXL memory, total capacity visible to SW.

Intel® Xeon® 6700-Series Processors with E-Cores DDR5 Memory Population Table

(2 Processors and 32 DIMMs Installed)

1 Processor DIMM Count	Memory Population Sequence
1 Processor and 1 DIMM	P1-DIMMA1

Intel® Xeon® 6700-Series Processors with E-Cores DDR5 Memory Population Table (2 Processors and 32 DIMMs Installed)	
1 Processor and 4 DIMMs	P1-DIMMA1/P1-DIMMC1/P1-DIMME1/P1-DIMMG1
1 Processor and 4 DIMMs	P1-DIMMB1/P1-DIMMD1/P1-DIMMF1/P1-DIMMH1
1 Processor and 8 DIMMs	P1-DIMMA1/P1-DIMMA2/P1-DIMMC1/P1-DIMMC2/P1-DIMME1/P1-DIMME2/P1-DIMMG1/P1-DIMMG2
1 Processor and 8 DIMMs	P1-DIMMB1/P1-DIMMB2/P1-DIMMD1/P1-DIMMD2/P1-DIMMF1/P1-DIMMF2/P1-DIMMH1/P1-DIMMH2
1 Processor and 8 DIMMs (*)	P1-DIMMA1/P1-DIMMB1/P1-DIMMC1/P1-DIMMD1/P1-DIMME1/P1-DIMMF1/P1-DIMMG1/P1-DIMMH1
1 Processor and 16 DIMMs	P1-DIMMA1/P1-DIMMA2/P1-DIMMB1/P1-DIMMB2/P1-DIMMC1/P1-DIMMC2/P1-DIMMD1/P1-DIMMD2/P1-DIMME1/P1-DIMME2/P1-DIMMF1/P1-DIMMF2/P1-DIMMG1/P1-DIMMG2/P1-DIMMH1/P1-DIMMH2
2 Processor DIMM Count (Recommended)	Memory Population Sequence
2 Processors and 2 DIMMs	P1-DIMMA1 P2-DIMMA1
2 Processors and 8 DIMMs	P1-DIMMA1/P1-DIMMC1/P1-DIMME1/P1-DIMMG1 P2-DIMMA1/P2-DIMMC1/P2-DIMME1/P2-DIMMG1
2 Processors and 8 DIMMs	P1-DIMMB1/P1-DIMMD1/P1-DIMMF1/P1-DIMMH1 P2-DIMMB1/P2-DIMMD1/P2-DIMMF1/P2-DIMMH1
2 Processors and 16 DIMMs	P1-DIMMA1/P1-DIMMA2/P1-DIMMC1/P1-DIMMC2/P1-DIMME1/P1-DIMME2/P1-DIMMG1/P1-DIMMG2 P2-DIMMA1/P2-DIMMA2/P2-DIMMC1/P2-DIMMC2/P2-DIMME1/P2-DIMME2/P2-DIMMG1/P2-DIMMG2
2 Processors and 16 DIMMs	P1-DIMMB1/P1-DIMMB2/P1-DIMMD1/P1-DIMMD2/P1-DIMMF1/P1-DIMMF2/P1-DIMMH1/P1-DIMMH2 P2-DIMMB1/P2-DIMMB2/P2-DIMMD1/P2-DIMMD2/P2-DIMMF1/P2-DIMMF2/P2-DIMMH1/P2-DIMMH2

Intel® Xeon® 6700-Series Processors with E-Cores DDR5 Memory Population Table (2 Processors and 32 DIMMs Installed)	
2 Processors and 16 DIMMs (*)	P1-DIMMA1/P1-DIMMB1/P1-DIMMC1/P1-DIMMD1/P1-DIMME1/P1-DIMMF1/P1-DIMMG1/P1-DIMMH1 P2-DIMMA1/P2-DIMMB1/P2-DIMMC1/P2-DIMMD1/P2-DIMME1/P2-DIMMF1/P2-DIMMG1/P2-DIMMH1
2 Processors and 32 DIMMs (*)	P1-DIMMA1/P1-DIMMA2/P1-DIMMB1/P1-DIMMB2/P1-DIMMC1/P1-DIMMC2/P1-DIMMD1/P1-DIMMD2/P1-DIMME1/P1-DIMME2/P1-DIMMF1/P1-DIMMF2/P1-DIMMG1/P1-DIMMG2/P1-DIMMH1/P1-DIMMH2 P2-DIMMA1/P2-DIMMA2/P2-DIMMB1/P2-DIMMB2/P2-DIMMC1/P2-DIMMC2/P2-DIMMD1/P2-DIMMD2/P2-DIMME1/P2-DIMME2/P2-DIMMF1/P2-DIMMF2/P2-DIMMG1/P2-DIMMG2/P2-DIMMH1/P2-DIMMH2

Notes:

- The memory configurations with an asterisk (*) are recommended by Supermicro for optimal memory performance.
- DIMMs must be all DDR5-6400 rated RDIMMs.
- All DIMMs in a channel must have the same number of ranks (unless explicitly specified otherwise).
- x8 DIMMs and x4 DIMMs cannot be mixed in the same channel or same processor socket (see the memory support table above).
- Rank mixing is not allowed.
- Vendor mixing is not allowed.

Intel Xeon 6700-Series Processors with P-Cores

DDR5-6400 Memory Support for Intel® Xeon® 6700-Series Processors with P-Cores							
Type	Ranks Per DIMM, Data Width (Stack)	DIMM Capacity (GB)			Speed (MT/s); Voltage (V); Slots per Channel (SPC) and DIMMs per Channel (DPC)		
		DRAM Density			1DPC/2SPC	2DPC/2SPC	
		16 Gb	24 Gb	32 Gb			
		1DPC	2DPC	1DPC	2DPC	2DPC	+1.1 V

DDR5-6400 Memory Support for Intel® Xeon® 6700-Series Processors with P-Cores									
RDIMM	1Rx8	16 GB	-	24 GB	-	-	6400, 6000, 5600, 5200, 4800 (DDR5-6400 rated RDIMMs only)	5200, 4800 (DDR5-6400 rated RDIMMs only)	
	1Rx4	32 GB	-	48 GB	-	-			
	2Rx8	32 GB	32 GB	48 GB	-	-			
	2Rx4	64 GB	64 GB*	96 GB	96 GB*	128 GB*			
3DS RDIMM	4Rx4	-	128 GB	-	-	-	8000, 7200 (MRDIMM-8800 only)	N/A	
	8Rx4	-	256 GB	-	-	-		N/A	
MRDIMM	2Rx8	32 GB	-	-	-	-	8000, 7200 (MRDIMM-8800 only)	N/A	
	2Rx4	64 GB	-	-	-	-		N/A	

Note: The items marked with an asterisk (*) are supported in 1S/2S/4S/8S systems. All others support 1S/2S only.

CXL Memory Configuration Support for Intel® Xeon® 6700-Series Processors with P-Cores									
Native DDR5 Memory Per Socket				CXL Memory Per Socket					
Slot 0 DIMM Ranks	Slot 0 DIMM Capacity (GB)	DIMM Type	DRAM Density (Gb)	CXL Memory Channels	CXL Memory Type	CXL Capacity Per Device/Module	CXL Interleave	CXL Mode	4S and 8S support
2Rx4	96	10x4	24	2+2	DDR5 x8	96 GB	1x4*, 2x2, 4x1	1LM+Vol	Yes
2H 3DS	128	10x4	16	2+2	DDR5 x8, DDR x8	128 GB	1x4*, 2x2, 4x1	1LM+Vol	Yes
2Rx4	64	10x4	16	2+2	DDR5 x8	64 GB	hetero x12	Hetero	Yes
2Rx4	64	10x4	16	1+1	DDR5 x16	2ch 64 GB	hetero x12	Hetero	Yes
2Rx4	64	10x4	16	2+2+2+2	DDR5 x8	64 GB	1x8*, 2x4, 4x2	1LM+Vol	No
2Rx4	64	10x4	16	2	DDR5 x8	256 GB	1x2*	1LM+Vol	No

CXL Memory Configuration Support for Intel® Xeon® 6700-Series Processors with P-Cores

2Rx4	64	10x4	16	1+1	DDR4 x16, DDR5 x16	2ch 128 GB	1x2*	Intel Flat Memory Mode	No
------	----	------	----	-----	-----------------------------	---------------	------	------------------------------	----

Notes:

- The items with an asterisk (*) are the default settings in the BIOS.
- The Intel® Xeon® 6700-series processors with P-cores CXL memory configurations are 1DPC ('Slot 0') only for native DDR5.
- CXL Memory Channel: number of devices per root port, with root ports separated by "+," e.g. 2+2+2+2 = four root ports populated with two devices per root port.
- CXL Interleave: sets x ways, e.g. 2x4 = One set of two modules, interleaved four-way.
- CXL Modes:
 - 1LM + Vol = DDR5 ('1LM') and (volatile) CXL memory visible to SW as separate tiers, separately interleaved.
 - Hetero x12 = DDR5 and (volatile) CXL memory interleaved together in one 12-way set.
 - Flat Memory Mode = HW manages data movement between DDR5 and CXL memory, total capacity visible to SW.

Intel® Xeon® 6700-Series Processors with P-Cores DDR5 Memory Population Table

(2 Processors and 32 DIMMs Installed, 1DPC)

1 Processor DIMM Count	Memory Population Sequence (1DPC)
1 Processor and 1 DIMM	P1-DIMMA1
1 Processor and 4 DIMMs	P1-DIMMA1/P1-DIMMC1/P1-DIMME1/P1-DIMMG1 P1-DIMMB1/P1-DIMMD1/P1-DIMMH1/P1-DIMMF1
1 Processor and 8 DIMMs	P1-DIMMA1/P1-DIMMB1/P1-DIMMC1/P1-DIMMD1/P1-DIMME1/P1-DIMMF1/P1-DIMMG1/P1-DIMMH1
2 Processor (Recommended)	Memory Population Sequence (1DPC)
2 Processors and 8 DIMMs	P1-DIMMA1/P1-DIMMC1/P1-DIMME1/P1-DIMMG1 P2-DIMMA1/P2-DIMMC1/P2-DIMME1/P2-DIMMG1

Intel® Xeon® 6700-Series Processors with P-Cores DDR5 Memory Population Table	
(2 Processors and 32 DIMMs Installed, 1DPC)	
2 Processors and 8 DIMMs	P1-DIMMB1/P1-DIMMD1/P1-DIMMF1/P1-DIMMH1 P2-DIMMB1/P2-DIMMD1/P2-DIMMF1/P2-DIMMH1
2 Processors and 16 DIMMs	P1-DIMMA1/P1-DIMMB1/P1-DIMMC1/P1-DIMMD1/P1-DIMME1/P1-DIMMF1/P1-DIMMG1/P1-DIMMH1 P2-DIMMA1/P2-DIMMB1/P2-DIMMC1/P2-DIMMD1/P2-DIMME1/P2-DIMMF1/P2-DIMMG1/P2-DIMMH1

Intel® Xeon® 6700-Series Processors with P-Cores DDR5 Memory Population Table	
(2 Processors and 32 DIMMs Installed, 2DPC)	
1 Processor DIMM Count	Memory Population Sequence (2DPC)
1 Processor and 1 DIMM	P1-DIMMA1
1 Processor and 4 DIMMs	P1-DIMMA1/P1-DIMMC1/P1-DIMME1/P1-DIMMG1 P1-DIMMB1/P1-DIMMD1/P1-DIMMF1/P1-DIMMH1
1 Processor and 8 DIMMs	P1-DIMMA1/P1-DIMMB1/P1-DIMMC1/P1-DIMMD1/P1-DIMME1/P1-DIMMF1/P1-DIMMG1/P1-DIMMH1 P1-DIMMA1/P1-DIMMA2/P1-DIMMC1/P1-DIMMC2/P1-DIMME1/P1-DIMME2/P1-DIMMG1/P1-DIMMG2 P1-DIMMB1/P1-DIMMB2/P1-DIMMD1/P1-DIMMD2/P1-DIMMF1/P1-DIMMF2/P1-DIMMH1/P1-DIMMH2
1 Processor and 12 DIMMs	P1-DIMMA1/P1-DIMMA2/P1-DIMMB1/P1-DIMMC1/P1-DIMMC2/P1-DIMMD1/P1-DIMME1/P1-DIMME2/P1-DIMMF1/P1-DIMMG1/P1-DIMMG2/P1-DIMMH1
1 Processor and 16 DIMMs	P1-DIMMA1/P1-DIMMA2/P1-DIMMB1/P1-DIMMB2/P1-DIMMC1/P1-DIMMC2/P1-DIMMD1/P1-DIMMD2/P1-DIMME1/P1-DIMME2/P1-DIMMF1/P1-DIMMF2/P1-DIMMG1/P1-DIMMG2/P1-DIMMH1/P1-DIMMH2
2 Processor DIMM Count (Recommended)	Memory Population Sequence (2DPC)
2 Processors and 2 DIMMs	P1-DIMMA1 P2-DIMMA1

Intel® Xeon® 6700-Series Processors with P-Cores DDR5 Memory Population Table (2 Processors and 32 DIMMs Installed, 2DPC)	
2 Processors and 8 DIMMs	P1-DIMMA1/P1-DIMMC1/P1-DIMME1/P1-DIMMG1 P2-DIMMA1/P2-DIMMC1/P2-DIMME1/P2-DIMMG1
2 Processors and 8 DIMMs	P1-DIMMB1/P1-DIMMD1/P1-DIMMF1/P1-DIMMH1 P2-DIMMB1/P2-DIMMD1/P2-DIMMF1/P2-DIMMH1
2 Processors and 16 DIMMs	P1-DIMMA1/P1-DIMMB1/P1-DIMMC1/P1-DIMMD1/P1-DIMME1/P1-DIMMF1/P1-DIMMG1/P1-DIMMH1 P2-DIMMA1/P2-DIMMB1/P2-DIMMC1/P2-DIMMD1/P2-DIMME1/P2-DIMMF1/P2-DIMMG1/P2-DIMMH1
2 Processors and 16 DIMMs	P1-DIMMA1/P1-DIMMA2/P1-DIMMC1/P1-DIMMC2/P1-DIMME1/P1-DIMME2/P1-DIMMG1/P1-DIMMG2 P2-DIMMA1/P2-DIMMA2/P2-DIMMC1/P2-DIMMC2/P2-DIMME1/P1-DIMME2/P2-DIMMG1/P2-DIMMG2
2 Processors and 16 DIMMs	P1-DIMMB1/P1-DIMMB2/P1-DIMMD1/P1-DIMMD2/P1-DIMMF1/P1-DIMMF2/P1-DIMMH1/P1-DIMMH2 P2-DIMMB1/P2-DIMMB2/P2-DIMMD1/P2-DIMMD2/P2-DIMMF1/P2-DIMMF2/P2-DIMMH1/P2-DIMMH2
2 Processors and 24 DIMMs	P1-DIMMA1/P1-DIMMA2/P1-DIMMB1/P1-DIMMC1/P1-DIMMC2/P1-DIMMD1/P1-DIMME1/P1-DIMME2/P1-DIMMF1/P1-DIMMG1/P1-DIMMG2/P1-DIMMH1 P2-DIMMA1/P2-DIMMA2/P2-DIMMB1/P2-DIMMC1/P2-DIMMC2/P2-DIMMD1/P2-DIMME1/P2-DIMME2/P2-DIMMF1/P2-DIMMG1/P2-DIMMG2/P2-DIMMH1
2 Processors and 32 DIMMs	P1-DIMMA1/P1-DIMMA2/P1-DIMMB1/P1-DIMMB2/P1-DIMMC1/P1-DIMMC2/P1-DIMMD1/P1-DIMMD2/P1-DIMME1/P1-DIMME2/P1-DIMMF1/P1-DIMMF2/P1-DIMMG1/P1-DIMMG2/P1-DIMMH1/P1-DIMMH2 P2-DIMMA1/P2-DIMMA2/P2-DIMMB1/P2-DIMMB2/P2-DIMMC1/P2-DIMMC2/P2-DIMMD1/P2-DIMMD2/P2-DIMME1/P2-DIMME2/P2-DIMMF1/P2-DIMMF2/P2-DIMMG1/P2-DIMMG2/P2-DIMMH1/P2-DIMMH2

Notes:

- DIMMs must be all DDR5 RDIMM or all MRDIMMs.
- All DIMMs in a channel must have the same number of ranks (unless explicitly specified otherwise).
- x8 DIMMs and x4 DIMMs cannot be mixed in the same channel or same processor socket (see the memory support table above).
- Mixing of non-3DS and 3DS RDIMMs is not allowed in the same channel, across different channels, and across different sockets.
- 9x4 RDIMMs cannot be mixed with other DIMMs.
- All DDR5 DIMM must be in the same speed per processor socket.
- Rank mixing is not allowed.
- Mixing of DDR5 operating frequencies is not validated within a socket or across sockets by Intel. When DIMMs with different maximum frequencies are mixed in the same channel or across different channels across processor sockets, BIOS determines and sets the DIMM speed to the highest common frequency across all channels on the platform. For example, if a 6000 MT/s max frequency DIMM is installed in one channel and a 6400 MT/s max frequency DIMM in another, BIOS sets the platform speed to 6000 MT/s.
- Mixing memory made by different vendors is allowed for both RDIMM and 3DS RDIMM.
- The 1-DIMM per processor configuration supports only 16 GB 1Rx8 and 32 GB 2Rx8 modules.

General Guidelines for Optimizing Memory Performance

- It is recommended to use DDR5 memory of the same type, size, and speed.
- Mixed DIMM speeds can be installed. However, all DIMMs will run at the speed of the slowest DIMM.
- The motherboard will support an odd number amount of memory modules. However, to achieve the best memory performance, a balanced memory population is recommended.

DIMM Installation

Important: To avoid causing any damage to the memory module or the DIMM socket, do not use excessive force when pressing the release tabs on the ends of the DIMM socket. Handle memory modules with care. To avoid ESD-related damage to your memory modules or components, carefully follow all the instructions given in "[Static-Sensitive Devices](#)" on page 30.

1. Insert the desired number of DIMMs into the memory slots based on the recommended DIMM population table earlier in this section.
2. Push the release tabs outwards on both ends of the DIMM slot to unlock it.

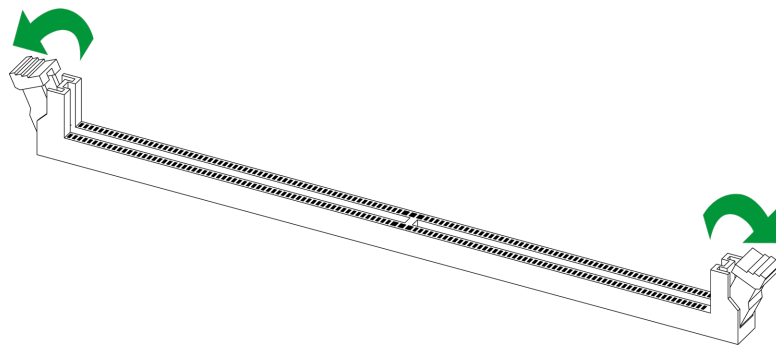

Figure 2-73. Unlocking the DIMM Slot

3. Align the key of the DIMM with the receptive point on the memory slot.

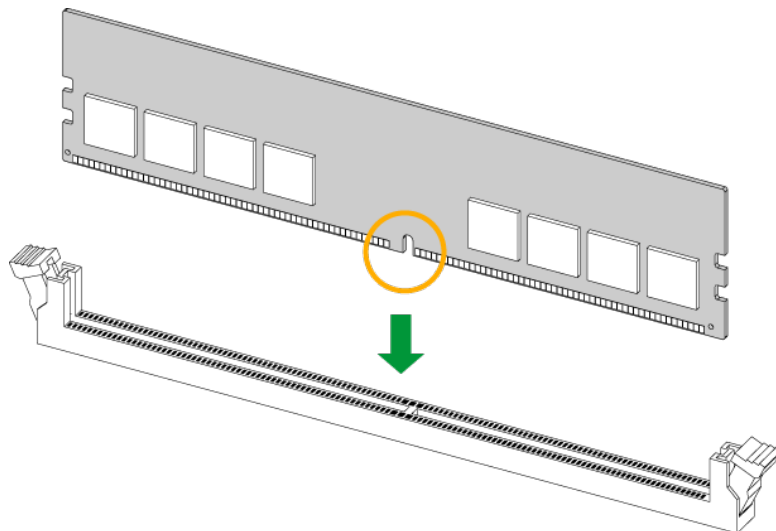

Figure 2-74. Aligning the DIMM Slot with the Receptive Point

- Align the notches on both ends of the module against the receptive points on the ends of the slot.

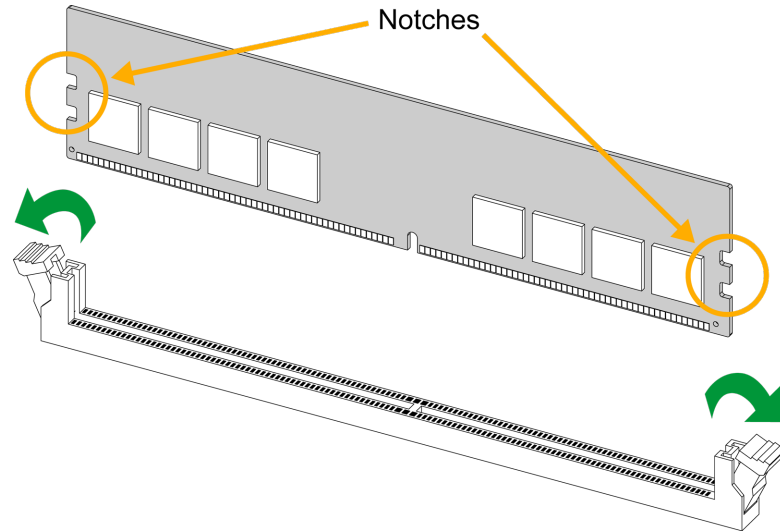

Figure 2-75. Aligning the Notches

- Press both ends of the module straight down into the slot until the module snaps into place.
- Press the release tabs to the lock positions to secure the DIMM into the slot.

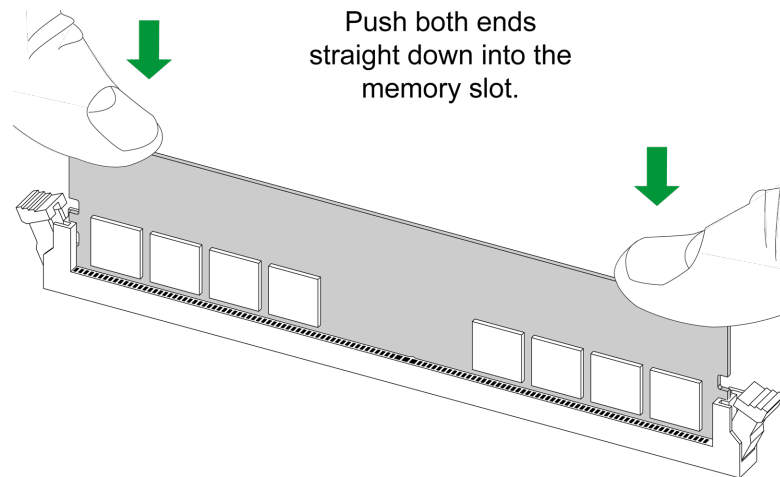

Figure 2-76. Securing the DIMM

For a detailed diagram of the X14DBM-SP motherboard, see the layout under ["Quick Reference"](#) on page 13.

DIMM Removal

Important: To avoid causing any damage to the memory module or the DIMM socket, do not use excessive force when pressing the release tabs on the ends of the DIMM socket. Handle memory modules with care. To avoid ESD-related damage to your memory modules or components, carefully follow all the instructions given in ["Static-Sensitive Devices"](#) on page 30.

Press both release tabs on the ends of the DIMM socket to unlock it. Once the DIMM is loosened, remove it from the memory slot.

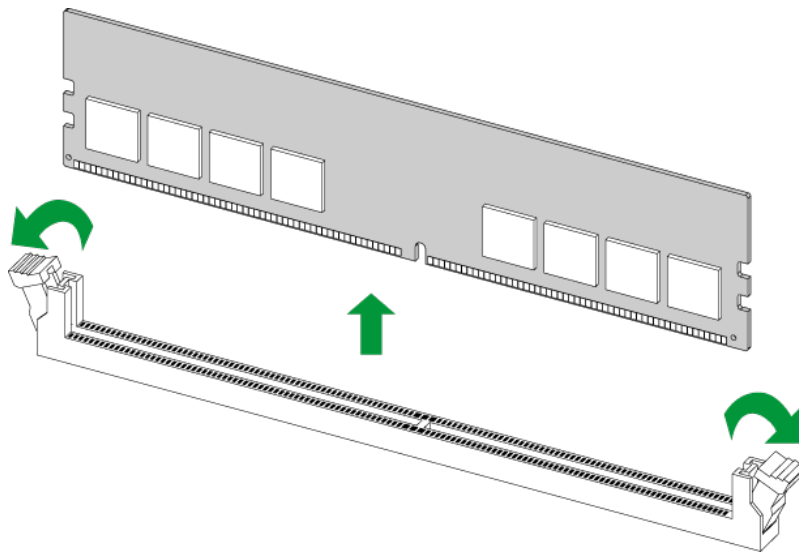

Figure 2-77. Unlocking the DIMM Slot

For a detailed diagram of the X14DBM-SP motherboard, see the layout under ["Quick Reference"](#) on page 13.

2.5 Battery Removal and Installation

Battery Removal

To remove the onboard battery, follow the steps below:

1. Power off your system and unplug your power cable.
2. Place the system on a workbench.
3. Locate the onboard battery as shown below.
4. Using a tool such as a pen or a small screwdriver, push the battery lock outwards to unlock it. Once unlocked, the battery will pop out from the holder.
5. Remove the battery.

Proper Battery Disposal

Important: Handle used batteries carefully. Do not damage the battery in any way; a damaged battery may release hazardous materials into the environment. Do not discard a used battery in the garbage or a public landfill. Comply with the regulations set up by your local hazardous waste management agency to dispose of your used battery properly.

Battery Installation

To install an onboard battery, follow steps 1 and 2 above and continue below:

Important: When replacing a battery, be sure to only replace it with the same type.

1. Identify the battery's polarity. The positive (+) side should be facing up.
2. Insert the battery into the battery holder and push it down until you hear a click to ensure that the battery is securely locked.

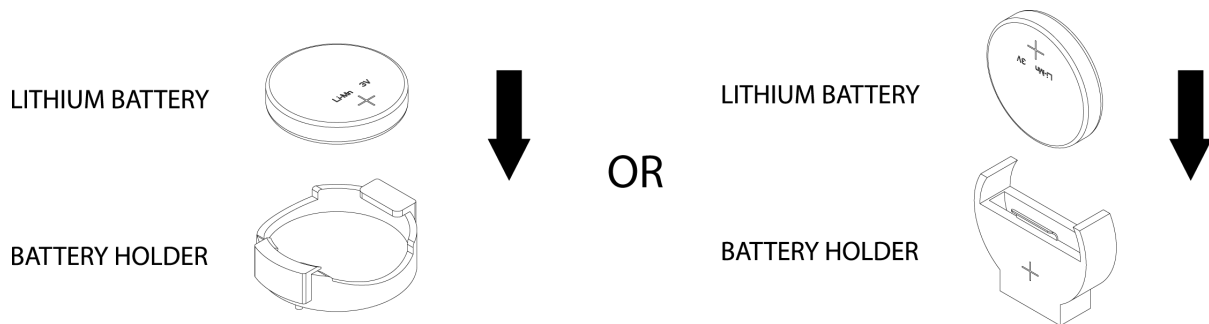

Figure 2-78. Installing a Battery

2.6 Connections, Jumpers, and LEDs

Refer to the following sections for information about connections, jumpers, and LEDs for the X14DBM-SP motherboard.

Power Supply and Power Connections

For information about the power supply and power connections of the X14DBM-SP motherboard, refer to the following content.

Power Supply

As with all computer products, a stable power source is necessary for proper and reliable operation. It is even more important for processors that have high CPU clock rates where noisy power transmission is present.

The X14DBM-SP Hyper Server board accommodates two Supermicro proprietary power supply units (PSU1/PSU2), two 6-pin +12 V power connectors (JPWR1/JPWR2), four 8-pin +12 V power connectors (JPMW1–JPMW4), and three 16-pin power connectors (JPMW5–JPMW7). Although most power supplies generally meet the specifications required by the processors, some are inadequate. All these power connections are also required to ensure adequate power supply to the system.

Important: To avoid damaging the power supply or the motherboard, be sure to use a power supply that accommodates two power supply units. Be sure to also connect the power supplies to four 8-pin +12 V power connectors (JPMW1–JPMW4), three 16-pin +12 V power connectors (PMW5–JPMW7), and two 6-pin power connectors (JPWR1/JPWR2) on the motherboard. Failure in doing so may void the manufacturer warranty on your power supply and motherboard.

It is strongly recommended that you use a high quality power supply that meets ATX power supply specification 2.02 or above. It must also be SSI compliant.

Note: The tables below represent the power supplies that support the main power supply units (PSU1/PSU2) in the Supermicro Hyper and Hyper-E servers. For detailed power supply support for your particular server, refer to your Hyper Server user manual.

- For Hyper Systems:

PWS-2K07A-1R
PWS-1K63A-1R
PWS-2K63A-1R
PWS-1K24A-1R

- For Hyper-E Systems:

PWS-2K08F-1R	PWS-1K30D-1R
PWS-2K08A-1R	PWS-1K30F-1R
PWS-2K08A-1R2	PWS-1K22F-1R
PWS-1K22A-1R	

6-Pin Riser Card Power Connectors (JPWR1/JPWR2)

Two 6-pin 12 V power connectors located at JPWR1 and JPWR2 on the X14DBM-SP motherboard are used for riser cards on the motherboard.

For a detailed diagram of the X14DBM-SP motherboard, see the layout under ["Quick Reference"](#) on page 13.

8-Pin/16-Pin Backplane/GPU Power Connectors (JPMW1–JPMW4 and JPMW5–JPMW7)

Four 8-pin 12 V power supply connectors (JPMW1–JPMW4) and another three 16-pin 12 V power connectors (JPMW5–JPMW7) on the X14DBM-SP motherboard are used to provide power to backplane and GPU devices via cables.

For a detailed diagram of the X14DBM-SP motherboard, see the layout under ["Quick Reference"](#) on page 13.

8-pin PWR Connector for Backplane/GPU Devices (JPMW1-4) Pin Definitions: 8 Total		16-pin PWR Connector for Backplane/GPU Devices (JPMW5-7) Pin Definitions: 16 Total	
Pin#	Definition	Pin#	Definition
1-4	GND	1-6	P12 V (12 V Power)
5-8	P12 V (12 V Power)	7-12	Ground
		S1 and S2	No Connection
		S3 and S4	Ground

Main Server Power Connectors (PSU1/PSU2)

Two power supply connectors, located at PSU1/PSU2, provide main server power to your hyper server.

Notes:

- The tables below represent the power supplies that are used with PSU1/PSU2 in Supermicro Hyper and Hyper-E servers. For detailed power supply support for your particular server, refer to your hyper server user manual.
- For Hyper Systems:

PWS-2K07A-1R
PWS-1K63A-1R
PWS-2K63A-1R
PWS-1K24A-1R

- For Hyper-E Systems:

PWS-2K08F-1R	PWS-1K30D-1R
PWS-2K08A-1R	PWS-1K30F-1R
PWS-2K08A-1R2	PWS-1K22F-1R
PWS-1K22A-1R	

- All power connectors used on this motherboard meet the ATX SSI EPS 12 V specification and must be connected to your power supply to provide adequate power to your system for all devices and components use.

For a detailed diagram of the X14DBM-SP motherboard, see the layout under "[Quick Reference](#)" on page 13.

Headers and Connections

For information about the headers on the X14DBM-SP motherboard, refer to the following content.

6-pin BMC External I²C Header

A System Management Bus header for the BMC is located at JF3_JIPMB1 on the X14DBM-SP motherboard.. Connect the appropriate cable here to use the IPMB I²C connection on your system.

For a detailed diagram of the X14DBM-SP motherboard, see the layout under "[Quick Reference](#)" on page 13.

BMC LAN/USB/VGA Connector

A low-profile SlimSAS I/O x8 connector, located at JIO1 on the X14DBM-SP motherboard, connects to an I/O mezzanine card, and provides dedicated BMC LAN/USB/VGA support for access.

For a detailed diagram of the X14DBM-SP motherboard, see the layout under ["Quick Reference" on page 13](#).

Chassis Intrusion

A Chassis Intrusion header is located at JL1 on the X14DBM-SP motherboard. Attach the appropriate cable from the chassis to inform you when the chassis is opened.

For a detailed diagram of the X14DBM-SP motherboard, see the layout under ["Quick Reference" on page 13](#).

Chassis Intrusion	
Pin Definitions: Two Total	
Pin#	Definition
1	Intrusion Input
2	GND

Expansion Slots

There are two PCIe 5.0 x16 slots on the X14DBM-SP motherboard. P1 SLOT1 PCIe 5.0 x16, located at JPCIE1, and P2 SLOT2 PCIe 5.0 x16, located at JPCIE5, support PCIe 5.0 x16 PCIe devices. P1 SLOT1 PCIe 5.0 x16 is supported by CPU1 while P2 SLOT2 PCIe 5.0 x16 is supported by CPU2.

For a detailed diagram of the X14DBM-SP motherboard, see the layout under ["Quick Reference" on page 13](#).

Fan Headers

There are eight 6-pin fan headers (FAN1–FAN8) and one 4-pin fan header (FAN10) on the motherboard. These fan headers are used for cooling fans for your system. Fan speed control for these fans is supported by thermal management via BMC 2.0 interface.

For a detailed diagram of the X14DBM-SP motherboard, see the layout under ["Quick Reference" on page 13](#).

Liquid Leak Check Header (JLC1)

A liquid leak check header is located at JLC1 on the X14DBM-SP motherboard.

For a detailed diagram of the X14DBM-SP motherboard, see the layout under "[Quick Reference](#)" on page 13.

M.2 M-Key PCIe 5.0 x2 Slots

Two M.2 M-key slots are located at M.2-C1 and M.2-C2 on the X14DBM-SP motherboard. The M.2 M-key slots on the motherboard support PCIe 5.0 x2 devices in a 2280/22110 form factor.

For a detailed diagram of the X14DBM-SP motherboard, see the layout under "[Quick Reference](#)" on page 13.

MCIO NVMe Connectors

MCIO NVMe connectors, located at P0_NVME0–P0_NVME3 and P1_NVME0–P1_NVME3, provide eight PCIe 5.0 x8 connections on the motherboard. P0_NVME0–P0_NVME3 connections are supported by CPU1, and P1_NVME0–P1_NVME3 connections, by CPU2. Use these MCIO connectors to support high-speed PCIe storage devices.

Note: When installing an NVMe device on a motherboard, be sure to connect the first NVMe port (P0_NVME0) first for your system to work properly.

For a detailed diagram of the X14DBM-SP motherboard, see the layout under "[Quick Reference](#)" on page 13.

MCIO PCIe 5.0 x8 Connectors

Mini Cool Edge IO (MCIO) PCIe 5.0 x8 connectors are located at JPCIE2A1, JPCIE2B1, JPCIE3, JPCIE4A1, JPCIE4B1, JPCIE6A1, and JPCIE6B1 on the X14DBM-SP motherboard. The connectors JPCIE2A1 and JPCIE2B1 are supported by CPU1, while JPCIE3, JPCIE4A1, JPCIE4B1, JPCIE6A1, and JPCIE6B1 are supported by CPU2.

For a detailed diagram of the X14DBM-SP motherboard, see the layout under "[Quick Reference](#)" on page 13.

NC-SI Connection

The Network Controller Sideband Interface (NC-SI) connection is located at JNCSI1 on the X14DBM-SP motherboard. This connection is used to connect a Network Interface Card (NIC) to the motherboard to allow the onboard Baseboard Management Controller (BMC) to communicate with a network.

Note: For detailed instructions on how to configure Network Interface Card (NIC) settings, refer to the Network Interface Card Configuration User's Guide posted on the web page under the link: <https://www.supermicro.com/support/manuals>.

For a detailed diagram of the X14DBM-SP motherboard, see the layout under "[Quick Reference](#)" on page 13.

NVMe SMBus Header

An NVMe SMBus (I²C) header is located at JNVI²C1 on the X14DBM-SP motherboard. It is used for PCIe SMBus clock and data connections, and provides hot-plug support through a dedicated SMBus interface. This feature is only available for a Supermicro complete system with a Supermicro proprietary NVMe add-on card and a proper cable installed.

For a detailed diagram of the X14DBM-SP motherboard, see the layout under "[Quick Reference](#)" on page 13.

NVMe SMBus Header	
Pin Definitions: Four Total	
Pin#	Definition
1	Data
2	GND
3	Clock
4	VCCIO

NVMe VPP Bus Connector

A NVMe VPP Bus connector is located at JNVVPP1 on the X14DBM-SP motherboard. The NVMe VPP connector provides hot plug support for the NVMe devices, which allows the user to replace NVMe devices without shutting down and powering off the system.

For a detailed diagram of the X14DBM-SP motherboard, see the layout under "[Quick Reference](#)" on page 13.

TPM/Port 80 Header

The JTPM1 header on the X14DBM-SP motherboard is used to connect a Trusted Platform Module (TPM)/Port 80, which is available from Supermicro (optional). A TPM/Port 80 connector is a security device that supports encryption and authentication in storage drives. It allows the motherboard to deny access if the TPM associated with the storage drive is not installed in the system. Information on the TPM is available at the following page:

https://www.supermicro.com/manuals/other/AOM-TPM-9670V_9670H_X12_H12.pdf

For a detailed diagram of the X14DBM-SP motherboard, see the layout under "[Quick Reference](#)" on page 13.

Trusted Platform Module Header			
Pin Definitions: 10 Total			
Pin#	Definition	Pin#	Definition
1	+3.3 V	2	SPI_CS#
3	RESET#	4	SPI_MISO
5	SPI_CLK	6	Ground
7	SPI_MOSI	8	No Connection
9	+1.8 V Standby	10	SPI_IRQ#

VROC RAID Key Header

A VROC RAID Key header is located at JRK1 on the X14DBM-SP motherboard. Install a VROC RAID key on JRK1 for NVMe RAID support as shown in the illustration below.

For a detailed diagram of the X14DBM-SP motherboard, see the layout under "[Quick Reference](#)" on page 13.

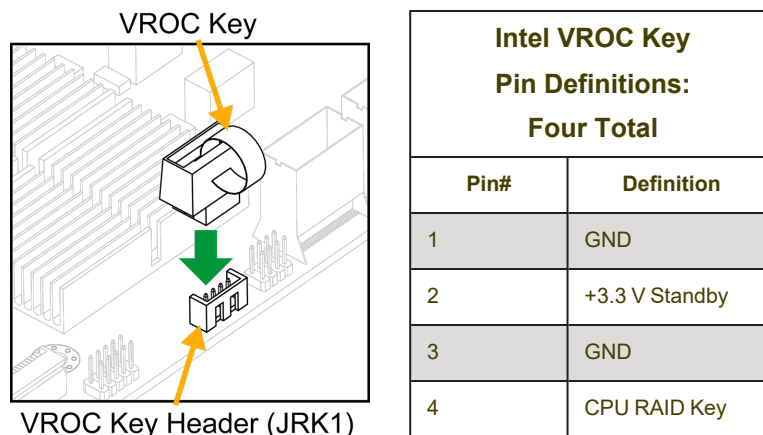

Note: Images displayed are for illustrative purposes only. The components installed in your system may or may not look exactly the same as the graphics shown in the manual.

Note: For detailed instructions on how to configure VROC RAID settings, refer to the VROC RAID Configuration User's Guide posted on the web page under the following link: <https://www.supermicro.com/support/manuals>.

Control Panel

Refer to the following content for information about the front control panel header on the X14DBM-SP motherboard.

Front Control Panel Header with I²C

There are two front control panel headers located on this motherboard.

JFP1 on the X14DBM-SP motherboard contains header pins for various buttons and indicators that are normally located on a control panel at the front of the chassis. These connectors are designed specifically for use with Supermicro chassis. See the figure below for the descriptions of the front control panel buttons and LED indicators.

For a detailed diagram of the X14DBM-SP motherboard, see the layout under ["Quick Reference"](#) on page 13.

JFP1	
1	○ Power Button
2	○ Reset/UID Button
3	○ UID LED_N
4	○ Fail LED_N (OH/FF/PF)
5	○ LAN-2 Activity LED
6	○ LAN-1 Activity LED (Aggregate all LAN)
7	○ Storage Drive Activity LED
8	○ Standby LED_N
9	○ Power/RoT LED_N
10	○ P3V3_STBY
11	○ GND
12	○ I2C Data
13	○ I2C Clock
14	○ GND
15	○ Power Fail LED_P
16	○ P5V_USB
17	○ P5V_USB
18	○ P5V_USB
19	○ Power Fail LED_N
20	○ GND

Figure 2-79. JFP1 Header Pins

Power On and BMC/BIOS Status LED Button

The Power On and BMC/BIOS Status LED button is located on pin 1 of the front control panel header located at JFP1 on the X14DBM-SP motherboard. Momentarily contacting pin 1 of JFP1 will power on/off the system or display BMC/BIOS status.

For a detailed diagram of the X14DBM-SP motherboard, see the layout under ["Quick Reference"](#) on page 13.

Power Button	
BMC/BIOS Status LED Indicator	
Status	Event
Green: Solid on	System power on
BMC/BIOS blinking green at 4 Hz	BMC/BIOS checking
BIOS blinking green at 4 Hz	BIOS recovery/update in progress
BMC blinking red x2 (two blinks red) at 4 Hz, one pause at 2 Hz (on-on-off-off)	BMC recovery/update in progress
BMC/BIOS blinking green at 1 Hz	Flash not detected or golden image checking failure

UID LED

The unit identifier LED connection is located on pin 3 of JFP1 on the X14DBM-SP motherboard.

For a detailed diagram of the X14DBM-SP motherboard, see the layout under "[Quick Reference](#)" on page 13.

Fail LED (Information LED for OH/FF/PF)

The Fail LED (Information LED for OH/Fan Fail/PWR Fail) connection, located on pin 4 of JFP1, provides warnings of overheating, power failure, or fan failure for the system.

For a detailed diagram of the X14DBM-SP motherboard, see the layout under "[Quick Reference](#)" on page 13.

Fail LED (Information LED) (OH/Fan Fail/PWR Fail)	
LED States	
Status	Description
Solid red (on)	An overheat condition has occurred.
Blinking red (1 Hz)	Fan failure: check for an inoperative fan.
Blinking red (0.25 Hz)	Power failure: check for a non-operational power supply.
Blinking red (10 Hz) (FP red LED)	CPLD recovery mode error(s).
Solid blue	UID has been activated locally. Use this function to locate a unit in the system that might be in need of service.
Blinking blue (1 Hz)	Local UID has been activated locally on. Use this function to identify a unit that might be in need of service.
BIOS/BMC blinking blue (10 Hz)	BIOS/BMC: recovery and/or update in progress.

Fail LED (Information LED) (OH/Fan Fail/PWR Fail)	
LED States	
Status	Description
Red Info LED blinking (10 Hz) and MB UID LED blue blinking (10 Hz)	CPLD: recovery and/or update in progress.

LAN1/LAN2 (NIC1/NIC2) LED

The Network Interface Controller (NIC) LED connection for LAN Port 1 is located on pin 6 of JFP1 on the X14DBM-SP motherboard, and LAN Port 2 is on pin 5.

For a detailed diagram of the X14DBM-SP motherboard, see the layout under ["Quick Reference"](#) on page 13.

LAN1/LAN2 LED	
LED States	
Color	State
NIC 2: Blinking green	LAN 2: Active
NIC 1: Blinking green	LAN 1: Active

Storage Drive Activity LED

The storage drive activity LED connection is located on pin 7 of JFP1 on the X14DBM-SP motherboard. When this LED is blinking green, it indicates storage drive activity.

For a detailed diagram of the X14DBM-SP motherboard, see the layout under ["Quick Reference"](#) on page 13.

Storage Drive Activity LED	
LED State	
Color	State
Blinking Green	Storage Drive Activity

Standby Power LED

The LED indicator for standby power is located on pin 8 of JFP1 on the X14DBM-SP motherboard. If this LED is on, standby power is on.

For a detailed diagram of the X14DBM-SP motherboard, see the layout under ["Quick Reference"](#) on page 13.

Root of Trust (RoT) Power LED

The Power LED for the Root of Trust (RoT) connection is located on pin 9 of JFP1 on the X14DBM-SP motherboard. If this LED is on, power for the RoT chip is on.

For a detailed diagram of the X14DBM-SP motherboard, see the layout under "[Quick Reference](#)" on page 13.

Standby Power

A Standby Power (I²C) connection is located on pins 10–14 of JFP1 on the X14DBM-SP motherboard to provide power to the system when it is in standby mode.

For a detailed diagram of the X14DBM-SP motherboard, see the layout under "[Quick Reference](#)" on page 13.

+3.3 V Standby Power	
Pin Definitions: Five Total	
Pin#	Definition
10	+3.3 Standby
11	Ground
12	I ² C Data
13	I ² C Clock
14	Ground

Power Fail LED Indicators

Power Failure LED Indicators are located on pins 15 and 19 of JFP1 on the X14DBM-SP motherboard.

For a detailed diagram of the X14DBM-SP motherboard, see the layout under "[Quick Reference](#)" on page 13.

FP Power LED	
Pin Definitions (JFP1)	
Pin#	Definition
15	PWR Failure LED-Positive
19	PWR Failure LED-Negative

FP USB Power

Front panel USB power connections, located on pins 16–18 of JFP1, provide power to front USB devices.

For a detailed diagram of the X14DBM-SP motherboard, see the layout under ["Quick Reference"](#) on page 13.

FP USB PWR	
Pin Definitions: Three Total	
Pin#	Definition
16	+5 V USB PWR
17	
18	

Front Control Panel Header 2

In addition to front control panel header 1 (JFP1), front control panel header 2 (JFP2), also located on the front side of the chassis, provides additional functions, including USB and VGA support to the system.

For a detailed diagram of the X14DBM-SP motherboard, see the layout under ["Quick Reference"](#) on page 13.

I/O Connectors/Ports

Advanced I/O Module (AIOM) for I/O Support

A Supermicro proprietary Advanced I/O Module (AIOM) PCIe 5.0 x16 connector used for an add-on module is located at JAIOM1 (P1-AIOM PCIe 5.0 x16) on the X14DBM-SP motherboard. This AIOM connector provides input/output connections on the I/O face of your system.

For a detailed diagram of the X14DBM-SP motherboard, see the layout under ["Quick Reference"](#) on page 13.

AIOM Sideband Connector (JAIOMSB1)

A Supermicro proprietary Advanced I/O Module (AIOM) sideband connector supported by CPU1, located at JAIOMSB1 on the X14DBM-SP motherboard, provides PCIe 5.0 x16 (with OCP 3.0 support) for AIOM sideband connections.

For a detailed diagram of the X14DBM-SP motherboard, see the layout under ["Quick Reference"](#) on page 13.

BMC LAN/USB/VGA Connector

A low-profile SlimSAS I/O x8 connector, located at JIO1 on the X14DBM-SP motherboard, connects to an I/O mezzanine card, and provides dedicated BMC LAN/USB/VGA support for access.

For a detailed diagram of the X14DBM-SP motherboard, see the layout under ["Quick Reference"](#) on page 13.

Universal Serial Bus (USB) 3.2 Header

A USB header that supports two USB 3.2 Gen 1 ports (USB2/3) is located at JUSB1 on the motherboard. This USB header can be used for USB support via USB cables (not included).

For a detailed diagram of the X14DBM-SP motherboard, see the layout under ["Quick Reference"](#) on page 13.

JUSB1 (USB 3.2 Gen 1) Header			
Pin Definitions: 20 Total			
Pin#	Definitions	Pin#	Definitions
1	VBUS	11	IntA_P2_D+
2	IntA_P1_SSRX-	12	IntA_P2_D-
3	IntA_P1_SSRX+	13	GND
4	GND	14	IntA_P2_SSTX+
5	IntA_P1_SSTX-	15	IntA_P2_SSTX-
6	IntA_P1_SSTX+	16	GND
7	GND	17	IntA_P2_SSRX+
8	IntA_P1_D-	18	IntA_P2_SSRX-
9	IntA_P1_D+	19	VBUS
10	GND	20	No Connection

VGA Connection Ports

There are two VGA connections in your system. One VGA connection is located on the BMCLAN/USB/VGA slot (JIO1) on the I/O side of the X14DBM-SP motherboard. The other VGA header is located on the Front Panel Control Module (JFP2). These VGA connections provide analog interface support between the computer and the video displays.

The onboard VGA port is located on the I/O ports of the motherboard. Use this connection for VGA display.

For a detailed diagram of the X14DBM-SP motherboard, see the layout under ["Quick Reference"](#) on page 13.

Jumper Settings

To modify the operation of the motherboard, jumpers can be used to choose between optional settings. Jumpers create shorts between two pins to change the function of the connector. Pin 1 is identified with a square solder pad on the printed circuit board. See the diagram below for an example of jumping pins 1 and 2. Refer to the motherboard layout page for jumper locations.

Note: On two-pin jumpers, "Closed" means the jumper is on and "Open" means the jumper is off the pins.

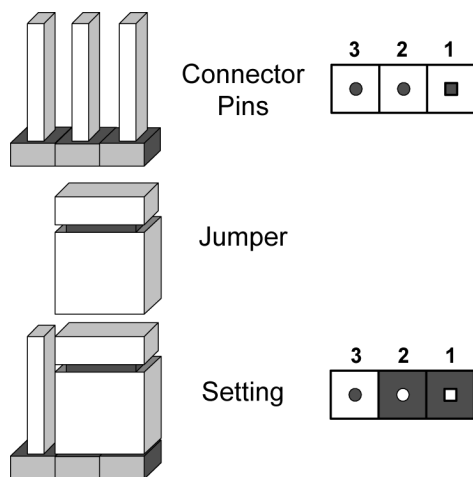

Figure 2-80. Jumping Connector Pins

CMOS Clear

JBT1 on the X14DBM-SP motherboard is used to clear CMOS, which will also clear any passwords. Instead of pins, this jumper consists of contact pads to prevent accidentally clearing the contents of CMOS.

For a detailed diagram of the X14DBM-SP motherboard, see the layout under "[Quick Reference](#)" on page 13.



1. First power down the system and unplug the power cord(s).
2. Remove the cover of the chassis to access the motherboard.
3. Remove the onboard battery from the motherboard.
4. Short the CMOS pads, JBT1, with a metal object such as a small screwdriver for at least four seconds.

Note: Clearing CMOS will also clear all passwords.

5. Remove the screwdriver (or shorting device).
6. Replace the cover, reconnect the power cord(s), and power on the system.

UID LED and System_Reset Button Select Jumper

Jumper JRU1 on the X14DBM-SP motherboard is used in conjunction with pin 2 of Front Control Panel header 1 (JFP1) to function as a System_Reset button or a UID LED button. To configure pin 2 of JFP1 for front UID button use in a chassis that supports front UID connection, close pins 1 and 2 of jumper JRU1. To set pin 2 of JFP1 for system reset support, close pins 3 and 4 of jumper JRU1.

For a detailed diagram of the X14DBM-SP motherboard, see the layout under ["Quick Reference" on page 13](#).

UID Switch/Reset Button Select Jumper (JRU1)	
Jumper Settings	
State	Description
Close pins 1 and 2 of JRU1	Pin 2 of JFP1: used for UID switch support
Close pins 3 and 4 of JRU1	Pin 2 of JFP1: used for System Reset support

LED Indicators

For information about the LED indicators on the X14DBM-SP motherboard, refer to the following content.

BMC Heartbeat LED

A BMC Heartbeat LED is located at LEDBMC (LEDM1) on the X14DBM-SP motherboard. When this LED is blinking, the BMC is functioning normally.

For a detailed diagram of the X14DBM-SP motherboard, see the layout under ["Quick Reference" on page 13](#).

BMC Heartbeat LED Indicator	
LED Color	Definition
Green: Blinking	BMC Normal

BMC LAN LEDs

The dedicated BMC LAN connection on the X14DBM-SP motherboard features two LEDs. The LED on the right indicates activity, and the LED on the left indicates the speed of the connection.

For a detailed diagram of the X14DBM-SP motherboard, see the layout under ["Quick Reference" on page 13](#).

BMC LAN LEDs		
	Color/State	Definition
Link (left)	Green: Solid	100 Mbps
	Amber: Solid	1 Gbps
Activity (right)	Amber: Blinking	Active

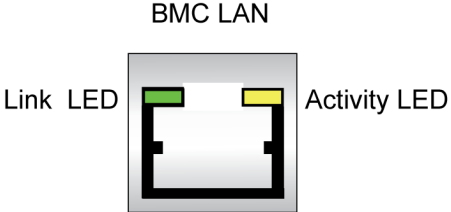

The diagram shows a network port labeled 'BMC LAN'. It has two LEDs: a green LED on the left labeled 'Link LED' and a yellow LED on the right labeled 'Activity LED'.

Onboard Power LED

The Onboard Power LED is located at LED1 on the X14DBM-SP motherboard. When this LED is on, the system is on. Be sure to turn off the system and unplug the power cord before removing or installing components.

For a detailed diagram of the X14DBM-SP motherboard, see the layout under ["Quick Reference" on page 13](#).

Onboard Power LED Indicator	
LED Color	Definition
Off	System Power Off (power cable not connected)
Green	System Power On

Unit ID (UID) LED

The UID LED indicator is located at LED2 on the X14DBM-SP motherboard. This UID indicator provides easy identification of a system that may need to be serviced.

For a detailed diagram of the X14DBM-SP motherboard, see the layout under ["Quick Reference" on page 13](#).

UID LED LED Indicator	
LED Color	Definitions
Blue: On	System Identified

Chapter 3:

Troubleshooting

The following content contains information on common issues and how to resolve them.

3.1 Troubleshooting Procedures	103
Before Power On	103
No Power	103
No Video	103
System Boot Failure	103
Memory Errors	104
Losing the System's Setup Configuration	104
If the System Becomes Unstable	104
3.2 Technical Support Procedures	106
3.3 Frequently Asked Questions	107
3.4 Returning Merchandise for Service	108

3.1 Troubleshooting Procedures

Use the following procedures to troubleshoot your system. If you have followed all of the procedures below and still need assistance, refer to the ["Technical Support Procedures" on page 106](#) or ["Returning Merchandise for Service" on page 108](#) section(s) in this chapter. Always disconnect the AC power cord before adding, changing or installing any non hot-swap hardware components. If the below steps do not fix the setup configuration problem, contact your vendor for repairs.

Before Power On

1. Make sure that there are no short circuits between the motherboard and chassis.
2. Disconnect all ribbon/wire cables from the motherboard, including those for the keyboard and mouse.
3. Remove all add-on cards.
4. Install the processor (making sure it is fully seated) and connect the front panel connectors to the motherboard.

No Power

1. Make sure that there are no short circuits between the motherboard and the chassis.
2. Make sure that the power connectors are properly connected.
3. Check that the 115 V/230 V switch, if available, on the power supply is properly set.
4. Turn the power switch on and off to test the system, if applicable.
5. Check the processor socket for bent pins and make sure the processor is fully seated.
6. The battery on your motherboard may be old. Check to verify that it still supplies approximately 3 VDC. If it does not, replace it with a new one.

No Video

1. If the power is on, but you do not have video, remove all add-on cards and cables.
2. Remove all memory modules and turn on the system (if the alarm is on, check the specs of memory modules, reset the memory, or try a different one).

System Boot Failure

If the system does not display Power-On-Self-Test (POST) or does not respond after the power is turned on, do the following:

1. Check the screen for an error message.
2. Clear the CMOS settings by unplugging the power cord and contacting both pads on the CMOS clear jumper. Restart the system. Refer to ["CMOS Clear" on page 99](#).
3. Remove all components from the motherboard and turn on the system with only one DIMM installed. If the system boots, turn off the system and repopulate the components back into the system to retest. Add one component at a time to isolate which one may have caused the system boot issue.

Memory Errors

When suspecting faulty memory is causing the system issue, check the following:

1. Make sure that the memory modules are compatible with the system and are properly installed. See ["Component Installation" on page 28](#) for installation instructions. (For memory compatibility, refer to the "Tested Memory List" link on the motherboard's product page to see a list of supported memory.)
2. Check if different speeds of DIMMs have been installed. It is strongly recommended that you use the same RAM type and speed for all DIMMs in the system.
3. Make sure that you are using the correct type of DIMMs recommended by the manufacturer.
4. Check for bad DIMMs or slots by swapping a single module among all memory slots and check the results.

Losing the System's Setup Configuration

1. Make sure that you are using a high-quality power supply. A poor-quality power supply may cause the system to lose the CMOS setup information. Refer to ["Introduction" on page 12](#) for details on recommended power supplies.
2. The battery on your motherboard may be old. Check to verify that it still supplies approximately 3 VDC. If it does not, replace it with a new one.

If the System Becomes Unstable

If the system becomes unstable during or after OS installation, check the following:

1. Processor/BIOS support: Make sure that your processor is supported and that you have the latest BIOS installed in your system.

2. Memory support: Make sure that the memory modules are supported. Refer to the product page on our website at <https://www.supermicro.com>. Test the modules using memtest86 or a similar utility.

Note: Click on the "Tested Memory List" link on the motherboard's product page to see a list of supported memory.

3. Storage Drive support: Make sure that all storage drives work properly. Replace the failed storage drives with good ones.
4. System cooling: Check the system cooling to make sure that all heatsink fans and processor/system fans, etc., work properly. Check the hardware monitoring settings in the IPMI to make sure that the processor and system temperatures are within the normal range. Also, check the front panel Overheat LED and make sure that it is not on.
5. Adequate power supply: Make sure that the power supply provides adequate power to the system. Make sure that all power connectors are connected. Refer to our website for more information on the minimum power requirements.
6. Proper software support: Make sure that the correct drivers are used.

If the system becomes unstable before or during OS installation, check the following:

1. Source of installation: Make sure that the devices used for installation are working properly, including boot devices such as a USB flash or media device.
2. Cable connection: Check to make sure that all cables are connected and working properly.
3. Use the minimum configuration for troubleshooting: Remove all unnecessary components (starting with add-on cards first), and use the minimum configuration (but with the processor and a memory module installed) to identify the trouble areas. Refer to the steps listed above in this section for proper troubleshooting procedures.
4. Identify bad components by isolating them: If necessary, remove a component in question from the chassis, and test it in isolation to make sure that it works properly. Replace a bad component with a good one.
5. Check and change one component at a time instead of changing several items at the same time. This will help isolate and identify the problem.
6. To find out if a component is good, swap this component with a new one to see if the system will work properly. If so, then the old component is bad. You can also install the component in question in another system. If the new system works, the component is good and the old system has problems.

3.2 Technical Support Procedures

Before contacting Technical Support, take the following steps. Also, note that as a motherboard manufacturer, Supermicro also sells motherboards through its channels, so it is best to first check with your distributor or reseller for troubleshooting services. They should know of any possible problems with the specific system configuration that was sold to you.

1. Refer to "Troubleshooting Procedures" on page 103 or see the FAQs on our website (<https://www.supermicro.com/FAQ/index.php>) before contacting Technical Support.
2. BIOS upgrades can be downloaded from our website (https://www.supermicro.com/support/resources/bios_ipmi.php).
3. If you still cannot resolve the problem, include the following information when contacting Supermicro for technical support:
 - Motherboard model and PCB revision number
 - BIOS release date/version (This can be seen on the initial display when your system first boots up.)
 - System configuration
4. An example of a Technical Support form is on our website at <https://webpr3.supermicro.com/SupportPortal>.
5. Distributors: For immediate assistance, have your account number ready when placing a call to our Technical Support department. For Supermicro contact information, refer to "Contacting Supermicro" on page 11.

3.3 Frequently Asked Questions

Question: What type of memory does my motherboard support?

Answer: This motherboard supports DDR5 (288-pin) memory with speeds up to 6400 MT/s (1DPC) or up to 5200 MT/s (2DPC). To enhance memory performance and ensure system stability, do not mixing memory modules of different speeds, different sizes, and different types in your server. Follow all memory installation instructions given on the [Memory Support and Installation](#) section.

Note: Memory speed and capacity support depend on the processors used in the system.

Question: How do I update my BIOS?

Answer: It is recommended that you do not upgrade your BIOS if you are not experiencing any problems with your system. Updated BIOS files are located on our website at https://www.supermicro.com/support/resources/bios_ipmi.php. Check our BIOS warning message and the information on how to update your BIOS on our website. Select your motherboard model and download the BIOS file to your computer. Also, check the current BIOS revision to make sure that it is newer than your BIOS before downloading.

Notes:

- The SPI BIOS chip used on this motherboard cannot be removed. Send your motherboard back to our RMA Department at Supermicro for repair.
- For BIOS Update and Recovery instructions, refer to the Firmware Update and Recovery Instructions for Supermicro's X14 Motherboards User's Guide posted at <https://www.supermicro.com/support/manuals>.
- When BIOS update is in progress, do not reset the BMC firmware.

3.4 Returning Merchandise for Service

A receipt or copy of your invoice marked with the date of purchase is required before any warranty service will be rendered. You can obtain service by calling your vendor for a Returned Merchandise Authorization (RMA) number. When returning the motherboard to the manufacturer, the RMA number should be prominently displayed on the outside of the shipping carton, and the shipping package is mailed prepaid or hand-carried. Shipping and handling charges will be applied for all orders that must be mailed when service is complete.

For faster service, RMA authorizations can be requested online at the following page:

<https://www.supermicro.com/RmaForm>

Whenever possible, repack the motherboard in the original Supermicro carton, using the original packaging material. If these are no longer available, be sure to pack the motherboard securely, using packaging material to surround the motherboard so that it does not shift within the carton and become damaged during shipping.

This warranty only covers normal consumer use and does not cover damages incurred in shipping or from failure due to the alternation, misuse, abuse or improper maintenance of products.

During the warranty period, contact your distributor first for any product problems.

Chapter 4:

UEFI BIOS

The following content contains information on BIOS configuration with the X14DBM-SP motherboard.

4.1 Introduction	110
4.2 Main Setup	112
4.3 Advanced Setup Configurations	114
4.4 Event Logs	154
4.5 BMC	156
4.6 Security	160
4.7 Boot	164
4.8 Save & Exit	166

4.1 Introduction

This chapter describes the AMIBIOS™ Setup utility for the motherboard. The BIOS is stored on a chip and can be easily upgraded using the UEFI script (flash.nsh), the BMC WebUI, or the SuperServer Automation Assistant (SAA) utility.

Note: Due to periodic changes to the BIOS, some settings may have been added or deleted and might not yet be recorded in this manual. Refer to the Manual Download area of our website for any changes to BIOS that may not be reflected in this manual.

Updating BIOS

It is recommended that you do not upgrade your BIOS if you are not experiencing any problems with your system. Updated BIOS files are located on our website at the following page:

https://www.supermicro.com/support/resources/bios_ipmi.php

Check our BIOS warning message and the information on how to update your BIOS on our website. Select your motherboard model and download the BIOS file to your computer. Also, check the current BIOS revision to make sure that it is newer than your BIOS before downloading.

Important: Do not shut down or reset the system while updating the BIOS to prevent possible system boot failure! Read the motherboard README file carefully before you perform the BIOS update.

To update the BIOS under the UEFI Shell, unzip the BIOS file onto a bootable USB device and then boot into the built-in UEFI Shell. For motherboards with BMC support, type "flash.nsh <BIOS filename><BMC Username><BMC Password>" to start the BIOS update. The flash.nsh script will invoke the SAA (EFI) tool automatically to perform the BIOS update, beginning with uploading the BIOS image to BMC. After uploading the BIOS image, the system will reboot to continue the process. The BMC will take over and continue the BIOS update in the background. The process will take 3–5 minutes. Refer to the README file for more information.

Starting the Setup Utility

To enter the BIOS Setup utility, press the <Delete> key while the system is booting-up. In most cases, the <Delete> key is used to invoke the BIOS Setup screen. There are a few cases when other hot keys are used, such as <F1>, <F2>, etc. Each main BIOS menu option is described in this manual.

The Main BIOS screen has two main frames. The left frame displays all the options that can be configured. "Grayed-out" options cannot be configured. The right frame displays the key legend. Above the key legend is an area reserved for a text message. When a BIOS submenu or item is selected in the left frame, it is highlighted in white. Often a text message will accompany it. (Note that BIOS has default text messages built in. We retain the option to include, omit, or change any of these text messages.) Settings printed in **Bold** are the default values.

A "▶" indicates a submenu. Highlighting such an item and pressing the <Enter> key open the list of settings within that submenu.

The BIOS Setup utility uses a key-based navigation system called hot keys. Most of these hot keys (<F1>, <F2>, <F3>, <F4>, <F5>, <F6>, <Enter>, <ESC>, the arrow keys, etc.) can be used at any time during the setup navigation process.

4.2 Main Setup

The Main setup screen appears when the AMI BIOS Setup utility is first entered. To return to the Main setup screen, select the Main tab at the top of the screen. The Main BIOS setup screen is shown below.

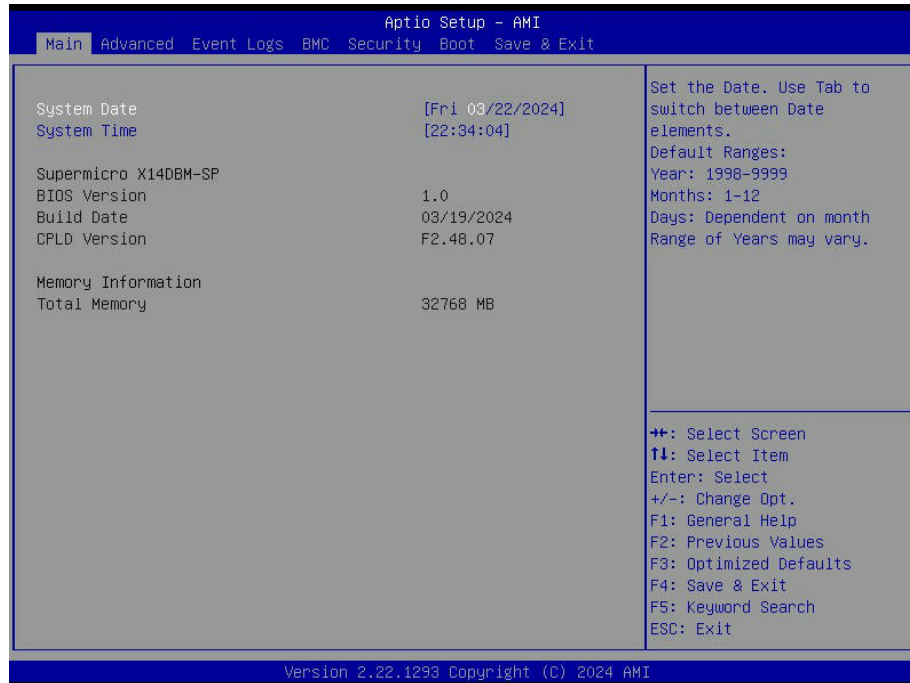

Figure 4-1. Main Setup Screen

System Date/System Time

Use the two features to change the system date and time. Highlight **System Date** or **System Time** using the arrow keys. Enter new values using the keyboard. Press the <Tab> key or the arrow keys to move between fields. The date must be entered in MM/DD/YYYY format. The time is entered in HH:MM:SS format.

Note: The time is in the 24-hour format. For example, 5:30 P.M. appears as 17:30:00.

Supermicro X14DBM-SP

BIOS Version

This feature displays the version of the BIOS ROM used in the system.

Build Date

This feature displays the date when the version of the BIOS ROM used in the system was built.

CPLD Version

This feature displays the version of the Complex-Programmable Logical Device (CPLD) used in the system.

Memory Information**Total Memory**

This feature displays the total size of memory available in the system.

4.3 Advanced Setup Configurations

Use the arrow keys to select the Advanced submenu and press <Enter> to access the submenu items.

Important: Use caution when changing the Advanced settings. An incorrect value, an improper DRAM frequency, or a wrong BIOS timing setting may cause the system to malfunction. When this occurs, revert the setting to the manufacture default settings.

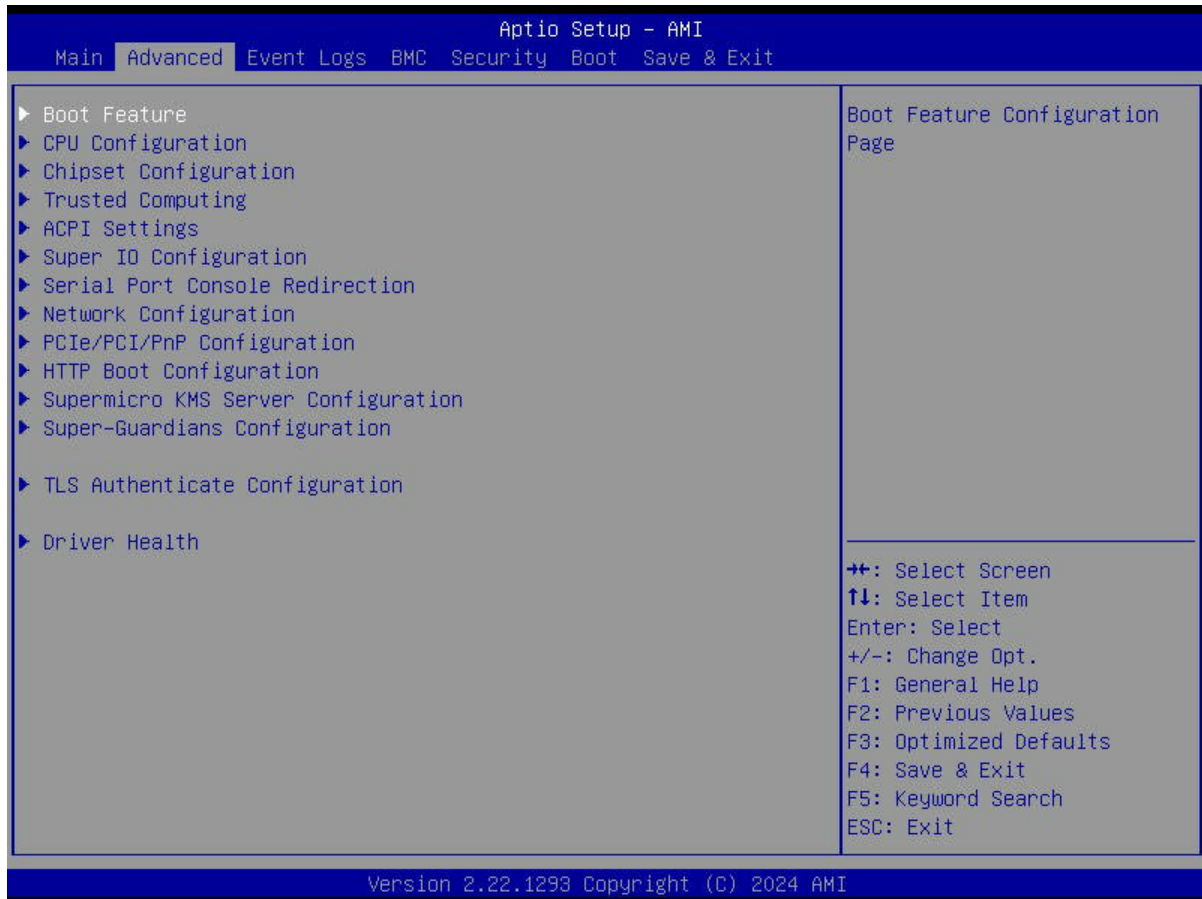

Figure 4-2. Advanced Screen

Boot Feature Menu

► Boot Feature

Quiet Boot

Use this feature to select the screen between displaying the Power-on Self Test (POST) messages or the OEM logo upon bootup. Select Disabled to display the POST messages. Select Enabled to display the OEM logo instead of the normal POST messages. The options

are Disabled and **Enabled**.

Note: BIOS POST messages are always displayed regardless of the setting of this feature.

Bootup NumLock State

Use this feature to set the Power-on state for the <Numlock> key. The options are **On** and Off.

Wait For "F1" If Error

Select Enabled to force the system to wait until the <F1> key is pressed if an error occurs. The options are **Disabled** and Enabled.

Re-try Boot

If this feature is set to Enabled, the system BIOS will automatically reboot the system from an Extensible Firmware Interface (EFI) boot device after an initial boot failure. The options are **Disabled** and Enabled.

Power Configuration

Watch Dog Function

Select Enabled to allow the Watch Dog timer to reboot the system when it is inactive for more than five minutes. The options are **Disabled** and Enabled.

Watch Dog Action (Available when "Watch Dog Function" is set to Enabled)

Use this feature to configure the Watch Dog Time_out setting. The options are **Reset** and NMI.

Restore on AC Power Loss

Use this feature to set the power state after a power outage. Select Stay Off for the system power to remain off after a power loss. Select Power On for the system power to be turned on after a power loss. Select Last State to allow the system to resume its last power state before a power loss. The options are Stay Off, Power On, and **Last State**.

Power Button Function

This feature controls how the system shuts down when the power button is pressed. Select 4 Seconds Override to power off the system after pressing and holding the power button for four seconds or longer. Select Instant Off to instantly power off the system as soon as you press the power button. The options are **Instant Off** and 4 Seconds Override.

CPU Configuration Menu

► CPU Configuration

Important: Setting the wrong values for the features included in the following sections may cause the system to malfunction.

The following processor information is displayed:

- Processor BSP Revision
- Processor Socket
- Processor ID
- Processor Frequency
- Processor Max Ratio
- Processor Min Ratio
- Microcode Revision
- L1 Cache RAM (Per Core)
- L2 Cache RAM (Per Core)
- L3 Cache RAM (Per Package)
- Processor 0 Version
- Processor 1 Version

Hyper-Threading [ALL]

Select Enabled to use Intel Hyper-Threading Technology to enhance CPU performance. The options are Disabled and **Enabled**. This feature is CPU-dependent.

Hardware Prefetcher

If this feature is set to Enabled, the hardware prefetcher will prefetch data from the main system memory to Level 2 cache to help expedite data transaction to enhance memory performance. The options are **Enabled** and Disabled.

Adjacent Cache Prefetch

Select Enabled for the CPU to prefetch both cache lines for 128 bytes as comprised. Select Disabled for the CPU to prefetch both cache lines for 64 bytes. The options are **Enabled** and Disabled.

DCU Streamer Prefetcher

If this feature is set to Enabled, the Data Cache Unit (DCU) streamer prefetcher will prefetch data streams from the cache memory to the DCU to speed up data accessing and processing to enhance CPU performance. The options are **Enabled** and Disabled.

DCU IP Prefetcher

This feature allows the system to use the sequential load history, which is based on the instruction pointer of previous loads, to determine whether the system will prefetch additional lines. The options are **Enabled** and Disabled.

LLC Prefetch

If this feature is set to Enabled, LLC (hardware cache) prefetching on all threads will be supported. The options are **Disabled** and Enabled. This feature is CPU-dependent.

Homeless Prefetch

Select Enabled for Homeless Prefetch support on all threads, which is an Effective Prefetch Strategy (EPS) used to enhance memory performance by reducing communication overhead, network latency, and the wait time needed for barrier synchronization in memory prefetching commonly associated with the home-based software Distributed Shared Memory (DSM) system. The options are Disabled, Enabled, and **Auto**. Please note that the option of Auto is program-specific. This feature is CPU-dependent.

AMP Prefetch

Select Enabled to use a machine learning algorithm to predict the best L2 prefetcher configuration for the currently running workload. This feature can improve the performance of various general-purpose workloads. The options are Disabled and **Enabled**. This feature is CPU-dependent.

APIC Physical Mode

This feature allows you to enable/disable the APIC physical destination mode. The options are **Disabled** and Enabled. (APIC is the abbreviation for Extended Advanced Programmable Interrupt Controller.)

TXT Support

Select Enabled to enable Intel Trusted Execution Technology (TXT) support to enhance system integrity and data security. The options are **Disabled** and Enabled. This feature is CPU-dependent.

Note: If this feature is set to Enabled, be sure to disable Device Function On-Hide (EV DFX) support when it is present in the BIOS for the system to work properly.

Intel Virtualization Technology (Unavailable when "TXT Support" is set to Enabled)

Select Enabled to enable the Intel Vanderpool Technology for Virtualization platform support, which allows multiple operating systems to run simultaneously on the same computer to maximize system resources for performance enhancement. The options are Disabled and **Enabled**.

Note: Please reboot the system for any change of the setting to take effect.

Enable SMX (Available when "TXT Support" is set to Disabled)

Select Enabled to support Safer Mode Extensions (SMX), which provides a programming interface for system software to establish a controlled environment to support the trusted platform configured by the end user and to verify a virtual machine monitor before it is allowed to run. The options are **Disabled** and Enabled.

PPIN Control

Select Unlock/Enabled to use the Protected Processor Inventory Number (PPIN) in the system. The PPIN is a unique number set for tracking a given Intel Xeon server processor. The options are Lock/Disabled and **Unlock/Enabled**.

AES-NI

Select Enabled to use the Intel Advanced Encryption Standard (AES) New Instructions (NI) to ensure data security. The options are Disabled and **Enabled**.

Advanced Power Management Configuration Menu**▶ Advanced Power Management Configuration****Power Performance Tuning**

This feature allows either operating system (OS) or BIOS to control the EPB. The options are **OS Controls EPB**, BIOS Controls EPB, and PCEI Controls EPB. (PCEI is the abbreviation for Platform Environment Control Interface. EPB is the abbreviation for Intel Performance and Energy Bias Hint.)

ENERGY_PERF_BIAS_CFG Mode (ENERGY PERFORMANCE BIAS CONFIGURATION Mode) (Available when "Power Performance Tuning" is set to BIOS Controls EPB)

Use this feature to configure the proper operation setting for your machine by achieving the desired system performance level and energy saving (efficiency) level at the same time. Select Performance to enhance system performance; however, this may consume more power as energy is needed to fuel the processors for operation. The options are Performance, **Balanced Performance**, Balanced Power, and Power.

CPU P State Control Menu**▶ CPU P State Control**

Note: This submenu is available when "Power Performance Tuning" is set to BIOS Controls EPB.

AVX P1 (Available when "SpeedStep (P-States)" is set to Enabled)

Use this feature to set the appropriate TDP level for the system. The Intel Advanced Vector Extensions (Intel AVX) P1 feature allows you to set the base P1 ratio for Streaming SIMD Extensions (SSE) and AVX workloads. Each P1 ratio has the corresponding AVX Impressed Current Cathodic Protection (ICCP) pre-grant license level, which refers to the selection between different AVX ICCP transition levels. The options are **Nominal**, Level 1, and Level 2. This feature is CPU-dependent.

The following information is CPU-dependent and will be displayed when "SpeedStep (P-States)" is set to Enabled:

- SST-PP Level
- Capable
- Core Count
- P1 Ratio
- Package TDP (W)
- DTS_Max

SpeedStep (P-States)

Enhanced Intel SpeedStep Technology (EIST) allows the system to automatically adjust processor voltage and core frequency in an effort to reduce power consumption and heat dissipation. Refer to Intel's website for detailed information. The options are Disabled and **Enable**.

EIST PSD Function (Available when "SpeedStep (P-States)" is set to Enabled)

This feature reduces the latency that occurs when one P-state changes to another, thus allowing the transitions to occur more frequently. This will allow for more demand-based P-state switching to occur based on the real-time energy needs of applications so that the power-to-performance balance can be optimized for energy efficiency. The options are **HW_ALL** and **SW_ALL**.

Turbo Mode (Available when "SpeedStep (P-States)" is set to Enabled)

Select Enable to allow the CPU to operate at the manufacturer-defined turbo speed by increasing CPU clock frequency. This feature is available when it is supported by the processors used in the system. The options are Disabled and **Enabled**.

Hardware PM State Control Menu

▶ **Hardware PM State Control**

Notes:

- This submenu is available when “Power Performance Tuning” is set to BIOS Controls EPB.
- This submenu is NOT available when “Workload Profile” is set to HPC, Virtualization, Telco NFVI, Telco NFVI-FP, or Telco FlexRAN.

Hardware P-States

If this feature is set to Disabled, system hardware will choose a P-state setting for the system based on an OS request. If this feature is set to Native Mode, system hardware will choose a P-state setting based on the OS guidance. If this feature is set to Native Mode with No Legacy Support, system hardware will choose a P-state setting independently without the OS guidance. The options are Disabled, **Native Mode**, Out of Band Mode, and Native Mode with No Legacy Support.

CPU C State Control Menu

▶ **CPU C State Control**

Notes:

- This submenu is available when “Power Performance Tuning” is set to BIOS Controls EPB.
- This submenu is NOT available when “Workload Profile” is set to Telco NFVI, Telco NFVI-FP, or Telco FlexRAN.

Monitor MWAIT

Select Enabled to support MONITOR and MWAIT, which are two instructions in Streaming SIMD Extension 3 (SSE3) to improve synchronization between multiple threads for CPU performance enhancement. The options are Disabled and **Enabled**.

Note: This feature is NOT available when “Workload Profile” is set to Telco NFVI, Telco NFVI-FP, or Telco FlexRAN.

C1 to C1e Promotion

If this feature is set to Enabled, CPU will run at its minimum frequency for lower power consumption in the C1 state. The options are Disabled and **Enabled**. This feature is CPU-dependent.

Note: This feature is available when "Workload Profile" is set to Disabled.

ACPI C1 Enumeration

Use this feature to select the ACPI C1 state or the ACPI C1e state. The options are C1 and **C1e**. This feature is CPU-dependent. (ACPI is the abbreviation for Advanced Configuration and Power Interface.)

Note: This feature is available when "Workload Profile" is set to Disabled.

ACPI C6x Enumeration

Use this feature to configure C6 state or C6 P-state as ACPI C2 or ACPI C3 state. The options are Disabled, C6 as ACPI C2, C6 as ACPI C3, C6-P as ACPI C2, C6-P as ACPI C3, and **Auto**.

Note: This feature is available when "Workload Profile" is set to Disabled.

Package C State Control Menu

► Package C State Control

Note: This submenu is available when "Power Performance Tuning" is set to BIOS Controls EPB.

Package C State

Use this feature to optimize and reduce CPU package power consumption in the idle mode. Please note that the changes you've made in this setting will affect all CPU cores or the circuits of the entire system. The options are C0/C1 state, C2 state, C6 (non Retention) state, No Limit, and **Auto**.

LTR IIO Input

Use this feature to set the MSR 1FCh Bit[35]. The options are Take IIO LTR input and **Ignore IIO LTR input**.

CPU1/CPU2 Core Disable Bitmap Menu

▶ CPU1/CPU2 Core Disable Bitmap

Note: The submenu of CPU2 Core Disable Bitmap is available when your motherboard supports dual processors.

Available Bitmap[0]:

This feature displays the available Bitmap[0]. This feature is CPU-dependent.

Available Bitmap[1]:

This feature displays the available Bitmap[1]. This feature is CPU-dependent.

CPU Core Count:

This feature displays the number of CPU cores that can be enabled.

CPU1/CPU2 Cores Enable

Use this feature to set the number of CPU cores to be enabled. Enter 0 to enable all CPU cores. Note that it is required to enable at least one core per CPU. The default setting is **0**.

Chipset Configuration Menu

▶ Chipset Configuration

Important: Setting the wrong values in this section may cause the system to malfunction.

Uncore Configuration Menu

▶ Uncore Configuration

The following information is displayed.

- Number of CPU
- Current UPI Link Speed
- Current UPI Link Frequency
- Global MMIO Low Base / Limit
- Global MMIO High Base / Limit
- PCIe Configuration Base / Size

Degrade Precedence

Use this feature to select the degrading precedence option for Ultra Path Interconnect (UPI) connections. Select Topology Precedent to degrade UPI features if system options are in conflict. Select Feature Precedent to degrade UPI topology if system options are in conflict. The options are **Topology Precedence** and Feature Precedence.

Link L0p Enable

Select Enabled for the system BIOS to enable Link L0p support, which allows the CPU to reduce the UPI links from full width to half width in the event when the CPU's workload is low in an attempt to save power. This feature is available for the system that uses Intel processors with UPI technology support. The options are **Disabled**, Enabled, and Auto.

Note: You can change the performance settings for non-standard applications by using this parameter. It is recommended that the default settings be used for standard applications.

Link L1 Enable

Select Enabled for the BIOS to activate Link L1 support, which will power down the UPI links to save power when the system is idle. This feature is available for the system that uses Intel processors with UPI technology support. The options are **Disabled**, Enabled, and Auto.

Note: Link L1 is an excellent feature for an idle system. L1 is used during Package C-States when its latency is hidden by other components during a wakeup.

KTI Prefetch

Keizer Technology Interconnect (KTI) is also known as the Intel Ultra Path Interconnect (UPI) technology. Select Enabled for the KTI prefetcher to preload the L1 cache with data deemed relevant, which allows the memory read to start earlier on a DDR bus in an effort to reduce latency. Select Auto for the KTI prefetcher to automatically preload the L1 cache with relevant data whenever is needed. The options are Disabled, Enabled, and **Auto**.

IO Directory Cache (IODC)

This feature allows the IODC to generate snoops instead of generating memory lockups for remote IIO (InvlToM) and/or WCiLF (Cores). Select Auto for the IODC to generate snoops (instead of memory lockups) for WCiLF (Cores). The options are Disabled, **Auto**, Enable for Remote InvltoM Hybrid Push, Enable for Remote InvltoM AllocFlow, Enable for Remote InvltoM Hybrid AllocNonAlloc, and Enable for Remote InvltoM and Remote WCiLF.

SNC

Sub NUMA Clustering (SNC) is a feature that breaks up the Last Level Cache (LLC) into clusters based on address range. Each cluster is connected to a subset of the memory controller. Enable this feature to improve average latency and reduce memory access

congestion for higher performance. The options are Disabled, Enabled, **Auto**. This feature is CPU-dependent.

XPT Prefetch

XPT Prefetch is a feature that speculatively makes a copy to the memory controller of a read request being sent to the LLC. If the read request maps to the local memory address and the recent memory reads are likely to miss the LLC, a speculative read is sent to the local memory controller. The options are Disabled, Enabled, and **Auto**.

Stale AtoS

The in-memory directory has three states: I, A, and S states. The I (-invalid) state indicates that the data is clean and does not exist in the cache of any other sockets. The A (-snoop All) state indicates that the data may exist in another socket in an exclusive or modified state. The S state (-Shared) indicates that the data is clean and may be shared in the caches across one or more sockets. When the system is performing "read" on the memory and if the directory line is in A state, we must snoop all other sockets because another socket may have the line in a modified state. If this is the case, a "snoop" will return the modified data. However, it may be the case that a line "reads" in an A state, and all the snoops come back with a "miss." This can happen if another socket reads the line earlier and then has silently dropped it from its cache without modifying it. If "Stale AtoS" is enabled, a line will transition to the S state when the line in the A state returns only snoop misses. That way, subsequent reads to the line will encounter it in the S state and will not have to snoop, saving the latency and snoop bandwidth. Stale "AtoS" may be beneficial in a workload where there are many cross-socket reads. The options are Disabled, Enabled, and **Auto**.

LLC Dead Line Alloc

Select Enabled to optimally fill the dead lines in the LLC. The options are Disabled, **Enabled**, and Auto.

Memory Configuration Menu

► Memory Configuration

This submenu is used to configure the Integrated Memory Controller (IMC) settings.

Enforce DDR Memory Frequency POR

Select Enforce POR to enforce Plan of Record (POR) restrictions for DDR memory frequency and voltage programming. The options are **Enforce POR**, Enforce Stretch Goals, and Disabled.

Host Memory Frequency

Use this feature to set the maximum memory frequency for onboard memory modules. The options are **Auto**, 4800, 5200, 5600, 6000, and 6400. Please note that the available options are CPU-dependent.

Global Scrambling

Select Enabled to enable data scrambling to enhance system performance and data integrity. The options are Disabled and **Enabled**.

Memory Topology Menu

▶ **Memory Topology**

This submenu displays the information of onboard memory modules as detected by the BIOS, for example:

P1-DIMMA1: 5600MT/s Hynix SRx8 16GB RDIMM

Memory Map Menu

▶ **Memory Map**

Intel(R) Flat Memory Mode Support

Enable this feature to allow hardware-managed data movement between DDR5 and CXL memory, making total memory capacity visible to your system. The options are **Disabled** and Enabled.

DDR CXL Heterogeneous Interleave Support

Select Enabled to support heterogeneous interleaving for physical DDR5 and CXL memory. The options are **Disabled** and Enabled.

Memory RAS Configuration Menu

▶ **Memory RAS Configuration**

Use this submenu to configure the memory mirroring, Reliability Availability Serviceability (RAS) settings.

Mirror Mode

Use this feature to configure the mirror mode settings for all 1LM/2LM memory modules in the system, which will create a duplicate copy of data stored in the memory to increase memory security, but it will reduce the memory capacity into half. The options are **Disabled** and Full Mirror Mode.

Note: This feature is available when "UEFI ARM Mirror" is set to Disabled.

UEFI ARM Mirror

If this feature is set to Enabled, mirror mode configuration settings for UEFI-based Address Range memory will be enabled upon system boot. This will create a duplicate copy of data stored in the memory to increase memory security, but it will reduce the memory capacity into half. The options are **Disabled** and Enabled. The Address Range Mirroring (ARM) feature supports partial memory mirroring. This feature is CPU-dependent.

Note: This feature is available when "Mirror Mode" is set to Disabled.

Mirror TAD0

Use this feature to enable the mirror mode on the entire memory for Target Address Decoder 0 (TAD0). The options are **Disabled** and Enabled. This feature is CPU-dependent.

Note: This feature is available when "Mirror Mode" is set to Disabled.

ARM Mirror Percentage (Available when "UEFI ARM Mirror" is set to Enabled)

Use this feature to set the percentage of memory space to be used for UEFI ARM mirroring for memory security enhancement. The default setting is **2500**.

Correctable Error Threshold

Use this feature to specify the threshold value for correctable memory-error logging, which sets a limit on the maximum number of events that can be logged in the memory error log at a given time. The default setting is **512**.

Note: This feature is available when "Memory PFA Support" is set to Disabled.

Leaky Bucket Low Bit

Use this feature to set the Low Bit value for the Leaky Bucket algorithm, which is used to check the data transmissions between CPU sockets and the memory controller. The default setting is **12**.

Leaky Bucket High Bit

Use this feature to set the High Bit value for the Leaky Bucket algorithm, which is used to check the data transmissions between CPU sockets and the memory controller. The default setting is **13**.

ADDDC Sparing (Available when populating 1Rx4, 2Rx4, and 4Rx4 DIMMs and when "Memory PFA Support" is set to Disabled)

Select Enabled for Adaptive Double Device Data Correction (ADDDC) support, which will not only provide memory error checking and correction but will also prevent the system from issuing a performance penalty before a device fails. Note that virtual lockstep mode will only start to work for ADDDC after a faulty DRAM module is spared. The options are Disabled and **Enabled**.

DDR PPR Type

Post Package Repair (PPR) is a new feature available for the DDR4/DDR5 technology. PPR provides additional spare capacity within a DDR4/DDR5 DRAM module that is used to replace faulty cell areas detected during system boot. PPR offers two types of memory repairs. Soft Post Package Repair (sPPR) provides a quick, temporary fix on a raw element in a bank group of a DDR4/DDR5 DRAM device, while hard Post Package Repair (hPPR) will take a longer time to provide a permanent repair on a raw element. The options are PPR Disabled, **Hard PPR**, and Soft PPR.

Note: This feature is available when "Memory PFA Support" is set to Disabled.

Enhanced PPR

Use this feature to set advanced memory test. Select Enabled to always execute for every boot. The options are **Disabled**, Enabled, and Persistent.

Memory PFA Support (Available when the DCMS key is activated)

Select Enabled to enable memory Predictive Failure Analysis (PFA) support. PFA can be used to avoid uncorrectable faults on the same memory page. The options are **Disabled** and Enabled.

Security Configuration Menu

► Security Configuration

 Memory Encryption (TME) [Outputs]

The following information is displayed.

- MSE activation state
- MK-TME activation state

- CI activation state
- Cryptographic Algorithm configured

 Memory Encryption (TME) [Inputs]

Memory Encryption (TME)

Select Enabled for Intel Total Memory Encryption (TME) support to enhance memory data security. The options are **Disabled** and Enabled.

Total Memory Encryption Multi-Tenant (TME-MT)

Use this feature to support tenant-provided (SW-provided) keys. The options are **Disabled** and Enabled.

Memory Integrity

Use this feature to enable TME-MT memory integrity protection for memory transactions. The options are **Disabled** and Enabled.

The following information is displayed.

- KEY stock amount
- TME-MT key ID bits

TME Encryption Algorithm

Use this feature to set the TME encryption algorithm. The options are AES-XTS-128 and **AES-XTS-256**.

 Trust Domain Extensions (TDX) [Outputs]

The following information is displayed.

- TDX activation state

 Trust Domain Extensions (TDX) [Inputs]

Trust Domain Extensions (TDX) (Available when your motherboard supports Intel TDX)

Use this feature to enable Intel Trust Domain Extensions (TDX) technology support to enhance control of data security. The options are **Disabled** and Enabled.

Note: To support TDX features, DIMM population must be symmetric across integrated Memory Controllers (IMCs) and at least eight DIMMs per socket. For each memory controller, populating the first slots (Px-DIMMX1 or DIMMX1 depending on the motherboard design) in all channels is required. Refer to memory population below for your motherboard.

TDX Memory Population for Intel Xeon 6700-Series Processors with E-Cores																	
IMC#	IMC4				IMC3				CPU	IMC1				IMC2			
Channel	P1/P2-DIMMH		P1/P2-DIMMG		P1/P2-DIMMF		P1/P2-DIMME			P1/P2-DIMMA		P1/P2-DIMMB		P1/P2-DIMMC		P1/P2-DIMMD	
	Slot1	Slot2	Slot1	Slot2	Slot1	Slot2	Slot1	Slot2		Slot2	Slot1	Slot2	Slot1	Slot2	Slot1	Slot2	Slot1
8	DDR5		DDR5		DDR5		DDR5			DDR5		DDR5		DDR5		DDR5	
16	DDR5	DDR5	DDR5	DDR5	DDR5	DDR5	DDR5	DDR5	DDR5	DDR5	DDR5	DDR5	DDR5	DDR5	DDR5	DDR5	DDR5

TDX Memory Population for Intel Xeon 6700/6500-Series Processors with P-Cores																	
IMC#	IMC4				IMC3				CPU	IMC1				IMC2			
Channel	P1/P2-DIMMH		P1/P2-DIMMG		P1/P2-DIMMF		P1/P2-DIMME			P1/P2-DIMMA		P1/P2-DIMMB		P1/P2-DIMMC		P1/P2-DIMMD	
	Slot1	Slot2	Slot1	Slot2	Slot1	Slot2	Slot1	Slot2		Slot2	Slot1	Slot2	Slot1	Slot2	Slot1	Slot2	Slot1
8	DDR5		DDR5		DDR5		DDR5			DDR5		DDR5		DDR5		DDR5	
12	DDR5		DDR5	DDR5	DDR5		DDR5	DDR5	DDR5	DDR5		DDR5	DDR5	DDR5		DDR5	DDR5
16	DDR5	DDR5	DDR5	DDR5	DDR5	DDR5	DDR5	DDR5	DDR5	DDR5	DDR5	DDR5	DDR5	DDR5	DDR5	DDR5	DDR5

TDX Secure Arbitration Mode Loader (SEAM Loader) (Available when your motherboard supports Intel TDX and when "Trust Domain Extensions (TDX)" is set to Enabled)

The SEAM Loader (SEAMLDR) is used to load and update Intel TDX modules into the SEAM memory range by verifying the digital signature. The options are **Disabled** and **Enabled**.

► **TDX Physical PCIe Configuration (Available when "Trust Domain Extension (TDX)" is set to Enabled)**

The following information is displayed.

- Available port bitmap [HEX]
- Disable port bitmap [HEX]

TME-MT/TDX Key Split (Available when "Trust Domain Extensions (TDX)" is set to Enabled)

Use this feature to set the number of bits for TDX. The other bits will be used by TME-MT. The default setting is **1**.

The following information is displayed when "Trust Domain Extensions (TDX)" is set to Enabled.

- TME-MT Keys:
- TDX Keys:

 Processor Reserved Memory [Capabilities]

The following information is displayed.

- PRMRR Min Size per domain
- PRMRR Max Size per domain

 Processor Reserved Memory [Outputs]

The following information is displayed.

- PRMRR Size per domain
- PRM Size per socket
- PRM Size per system

 Software Guard Extensions (SGX) [Outputs]

The following information is displayed when your motherboard supports SGX.

- SGX activation state
- SGX error code [HEX]

 Software Guard Extensions (SGX) [Inputs]

The following features are available when your motherboard supports SGX.

Note: To support SGX features, DIMM population must be symmetric across Integrated Memory Controllers (IMCs) and at least eight DIMMs per socket. For each memory controller, populating the first slots (Px-DIMMX1 or DIMMX1 depending on the motherboard design) in all channels is required. Refer to memory population below for your motherboard.

SGX Memory Population for Intel Xeon 6700-Series Processors with E-Cores																	
IMC#	IMC4				IMC3				CPU	IMC1				IMC2			
Channel	P1/P2-DIMMH		P1/P2-DIMMG		P1/P2-DIMMF		P1/P2-DIMME			P1/P2-DIMMA		P1/P2-DIMMB		P1/P2-DIMMC		P1/P2-DIMMD	
	Slot1	Slot2	Slot1	Slot2	Slot1	Slot2	Slot1	Slot2		Slot2	Slot1	Slot2	Slot1	Slot2	Slot1	Slot2	Slot1
8	DDR5		DDR5		DDR5		DDR5			DDR5		DDR5		DDR5		DDR5	
16	DDR5	DDR5	DDR5	DDR5	DDR5	DDR5	DDR5	DDR5	DDR5	DDR5	DDR5	DDR5	DDR5	DDR5	DDR5	DDR5	DDR5

SGX Memory Population for Intel Xeon 6700/6500-Series Processors with P-Cores																	
IMC#	IMC4				IMC3				CPU	IMC1				IMC2			
Channel	P1/P2-DIMMH		P1/P2-DIMMG		P1/P2-DIMMF		P1/P2-DIMME			P1/P2-DIMMA		P1/P2-DIMMB		P1/P2-DIMMC		P1/P2-DIMMD	
	Slot1	Slot2	Slot1	Slot2	Slot1	Slot2	Slot1	Slot2		Slot2	Slot1	Slot2	Slot1	Slot2	Slot1	Slot2	Slot1
8	DDR5		DDR5		DDR5		DDR5			DDR5		DDR5		DDR5		DDR5	
12	DDR5		DDR5	DDR5	DDR5		DDR5	DDR5	DDR5	DDR5		DDR5	DDR5		DDR5		DDR5
16	DDR5	DDR5	DDR5	DDR5	DDR5	DDR5	DDR5	DDR5	DDR5	DDR5	DDR5	DDR5	DDR5	DDR5	DDR5	DDR5	DDR5

SGX Factory Reset

Use this feature to perform an SGX factory reset to delete all registration data and force an Initial Platform Establishment flow. Reboot the system for the changes to take effect. The options are **Disabled** and Enabled.

SW Guard Extensions (SGX)

Use this feature to enable Intel Software Guard Extensions (SGX) support. Intel SGX is a set of extensions that increases the security of application code and data by using enclaves in memory to protect sensitive information. The options are **Disabled** and Enabled.

SGX Package Info In-Band Access

Setting this feature to Enabled is required before the BIOS provides software with the key blobs, which are generated for each CPU package. The options are **Disabled** and Enabled.

SGX PRMRR Size Requested (Available when "SW Guard Extensions (SGX)" is set to Enabled)

Use this feature to set the Processor Reserved Memory Range Register (PRMRR) size. The options are **Auto**, 128M, 256M, 512M, 1G, 2G, 4G, 8G, 16G, 32G, 64G, 128G, 256G, and 512G. Please note that the available options are based on your motherboard features, memory

size, and memory map.

SGX QoS (Available when "SW Guard Extensions (SGX)" is set to Enabled)

Use this feature to enable Intel SGX Quality of Service (QoS) support. QoS can enhance network performance by prioritizing network traffic. The options are Disabled and **Enabled**.

Select Owner EPOCH Input Type (Available when "SW Guard Extensions (SGX)" is set to Enabled)

Owner EPOCH is used as a parameter to add personal entropy into the key derivation process. A correct Owner EPOCH is required to have access to personal data previously sealed by other platform users. There are two Owner EPOCH modes. One is New Random Owner EPOCH, and the other is manually entered by the user. Each EPOCH is 64-bit. The options are **SGX Owner EPOCH deactivated**, Change to New Random Owner EPOCHs, and Manual User Defined Owner EPOCHs.

Note: Changing the Owner EPOCH value will lose the data in enclaves.

Software Guard Extensions Epoch 0

Use this feature to enter the EPOCH value. The default setting is **0**.

Note: This feature is available when "SW Guard Extensions (SGX)" is set to Enabled. This feature is NOT available when "Select Owner EPOCH Input Type" is set to SGX Owner EPOCH deactivated.

Software Guard Extensions Epoch 1

Use this feature to enter the EPOCH value. The default setting is **0**.

Note: This feature is available when "SW Guard Extensions (SGX)" is set to Enabled. This feature is NOT available when "Select Owner EPOCH Input Type" is set to SGX Owner EPOCH deactivated.

SGXLEPUBKEYHASHx Write Enable (Available when "SW Guard Extensions (SGX)" is set to Enabled)

Use this feature to enable writes to SGXLEPUBKEYHASH[3..0] from OS/SW. The options are Disabled and **Enabled**. Only those CPUs that support Intel SGX Flexible Launch Control (FLC) feature have SGXLEPUBKEYHASH, which contains the hash of the public key for the SGX Launch Enclave (LE) to be signed with.

SGXLEPUBKEYHASH0 (Available when both "SW Guard Extensions (SGX)" and "SGXLEPUBKEYHASHx Write Enable" are set to Enabled)

Use this feature to enter the bytes 0–7 of SGX Launch Enclave Public Key Hash.

The default setting is **0**.

SGXLEPUBKEYHASH1 (Available when both "SW Guard Extensions (SGX)" and "SGXLEPUBKEYHASHx Write Enable" are set to Enabled)

Use this feature to enter the bytes 8–15 of SGX Launch Enclave Public Key Hash.

The default setting is **0**.

SGXLEPUBKEYHASH2 (Available when both "SW Guard Extensions (SGX)" and "SGXLEPUBKEYHASHx Write Enable" are set to Enabled)

Use this feature to enter the bytes 16–23 of SGX Launch Enclave Public Key Hash.

The default setting is **0**.

SGXLEPUBKEYHASH3 (Available when both "SW Guard Extensions (SGX)" and "SGXLEPUBKEYHASHx Write Enable" are set to Enabled)

Use this feature to enter the bytes 24–31 of SGX Launch Enclave Public Key Hash.

The default setting is **0**.

SGX Auto MP Registration (Available when "SW Guard Extensions (SGX)" is set to Enabled)

Use this feature to enable/disable SGX Auto Multi-Package Registration Agent (MPA) running automatically at boot time. The options are **Disabled** and Enabled.

I/O Configuration Menu

► I/O Configuration

PCIe ASPM Support (Global)

Use this feature to disable the Active State Power Management (ASPM) support for all PCIe root ports. The options are **Disabled** and Auto.

CPU1/CPU2 Configuration Menu

► CPU1/CPU2 Configuration

Note: The submenu of CPU2 Configuration is motherboard-dependent.

► PCI Express 0 / PCI Express 1 / PCI Express 2 / PCI Express 3 / PCI Express 4 / PCI Express 5

Note: The number of PCIe slots and the slot naming can differ depending on the PCIe devices connected to your motherboard.

Intel VMD Technology

When this feature is set to Enabled, VMD support will be automatically enabled when a VROC key is detected by the BIOS. The options are **Disabled** and Enabled.

Notes:

- This feature is available when "NVMe Mode Switch" is set to Manual.
- After you've enabled VMD in the BIOS on a PCIe slot, this PCIe slot will be dedicated for VMD use only, and it will no longer support any PCIe device. To re-activate this slot for PCIe use, disable VMD in the BIOS.

Bifurcation

This feature is CPU-dependent. Use this feature to configure the PCIe Bifurcation setting for the PCIe port you specified. The options are **Auto**, x4x4x4x4, x4x4x8, x8x4x4, x8x8, and x16.

► PCI Express 5 Port A/Port C/Port E/Port G

Note: The number of PCIe slots and the slot naming can differ depending on the PCIe devices connected to your motherboard.

Requested Link Speed

Use this feature to configure the link speed for the PCIe port you specified. The options are **Auto**, Gen 1 (2.5 GT/s), Gen 2 (5 GT/s), Gen 3 (8 GT/s), Gen 4 (16 GT/s), and Gen 5 (32 GT/s).

The following information is displayed.

- Max Link Width
- Current Link Width
- Current Link Speed

Data Link Feature Exchange

Use this feature to enable data link feature negotiation in the Data Link Feature Capabilities (DLFCAP) register. The options are Disabled and **Enabled**.

PCIe Port Max Payload Size

Use this feature to configure the maximum payload size supported in Direct Media Interface (DMI) device capabilities register for the device installed in the PCIe port. The options are 128B, 256B, 512B, and **Auto**.

MCTP

Enable this feature, Management Component Transport Protocol (MCTP), to support communications between devices in a platform management subsystem. MCTP's underlying device buses include SMBus/I²C, serial links, PCIe, and USB. The options are Disabled and **Enabled**.

Equalization Bypass To Highest Rate

Set this feature to Enabled to reduce the link training time for PCIe 5.0 device by skipping equalization of intermediate data rates. The options are Disabled and **Enabled**.

Intel VMD Technology

When this feature is set to Enabled, VMD support will be automatically enabled when a VROC key is detected by the BIOS. The options are **Disabled** and Enabled.

Intel VT for Directed I/O (VT-d) Menu

► Intel VT for Directed I/O (VT-d)

Pre-boot DMA Protection

Select Enabled to establish DMA protection during pre-boot processing by setting DMA_CTRL_PLATFORM_OPT_IN_FLAG in the DMAR ACPI table. The options are **Enabled** and Disabled. (DMA is the abbreviation for Direct Memory Access. DMAR is the abbreviation for DMA Remapping Reporting.)

PCIe ACSCTL

Select Enabled to program ACS control to Chipset PCIe Root Port bridges. Select Disabled to program ACS control to all PCIe Root Port bridges. The options are Enabled and **Disabled**.

PCIe Leaky Bucket Configuration Menu

► PCIe Leaky Bucket Configuration

Gen2 Link Degradation

Use this feature to enable PCIe Gen2 link degradation. The options are Disabled and **Enabled**.

Note: The default setting is Enabled when your motherboard supports PCIe Gen2 link. Otherwise, the default setting is Disabled.

Gen3 Link Degradation

Use this feature to enable PCIe Gen3 link degradation. The options are Disabled and **Enabled**.

Note: The default setting is Enabled when your motherboard supports PCIe Gen3 link. Otherwise, the default setting is Disabled.

Gen4 Link Degradation

Use this feature to enable PCIe Gen4 link degradation. The options are Disabled and **Enabled**.

Note: The default setting is Enabled when your motherboard supports PCIe Gen4 link. Otherwise, the default setting is Disabled.

Gen5 Link Degradation

Use this feature to enable PCIe Gen5 link degradation. The options are Disabled and **Enabled**.

Note: The default setting is Enabled when your motherboard supports PCIe Gen5 link. Otherwise, the default setting is Disabled.

Trusted Computing Menu

► Trusted Computing

When the TPM 2.0 (either onboard or external) is detected by your system, the following information is displayed.

- TPM 2.0 Device Found
- Firmware Version:
- Vendor:

Note: This submenu is available when the TPM 2.0 (either onboard or external) is detected by the BIOS.

Security Device Support

Select Enabled to enable BIOS support for onboard security devices, which are not displayed in the OS. If this feature is set to Enabled, TCG EFI protocol and INT1A interface will not be available. The options are Disabled and **Enabled**.

When "Security Device Support" is set to Enabled and the TPM 2.0 (either onboard or external) is detected by the BIOS, the following information is displayed.

- Active PCR banks
- Available PCR banks

Note: The following features are available when the TPM 2.0 (either onboard or external) is detected by the BIOS.

ACPI Settings Menu

▶ ACPI Settings

NUMA

Use this feature to enable Non-Uniform Memory Access (NUMA) support to minimize memory access latencies. The options are Disabled and **Enabled**. This feature is CPU-dependent.

Virtual NUMA

Enable this feature to optimize the memory-access performance for VMware virtual machines. The options are **Disabled** and Enabled.

Number of Virtual NUMA Nodes (Available when "Virtual NUMA" is set to Enabled)

This feature displays the number of virtual NUMA nodes. A NUMA architecture divides hardware resources (including processors, memory, and I/O buses) into groups, called NUMA nodes. This feature indicates the available number of virtual NUMA nodes that can be assigned to the virtual machine. By default, this setting is automatically adjusted to match the physical NUMA topology.

WHEA Support

Select Enabled to support the Windows Hardware Error Architecture (WHEA) platform and provide a common infrastructure for the system to handle hardware errors within the Windows OS environment to reduce system crashes and to enhance system recovery and health monitoring. The options are Disabled and **Enabled**.

Super IO Configuration Menu

▶ Super IO Configuration

The following information is displayed.

- Super IO Chip

Note: This submenu is available when your system supports this feature.

Serial Port 1 Configuration Menu

► Serial Port 1 Configuration

Serial Port 1

Select Enabled to enable serial port 1. The options are Disabled and **Enabled**.

Device Settings (Available when "Serial Port 1" above is set to Enabled)

This feature displays the base I/O port address and the Interrupt Request address of serial port 1.

Change Settings (Available when "Serial Port 1" above is set to Enabled)

Use this feature to specify the base I/O port address and the Interrupt Request address of serial port 1. Select Auto for the BIOS to automatically assign the base I/O and IRQ address to serial port 1. The options are **Auto**, (IO=3F8h; IRQ=4;), (IO=3F8h; IRQ=3,4,5,6,7,9,10,11,12;), (IO=2F8h; IRQ=3,4,5,6,7,9,10,11,12;), (IO=3E8h; IRQ=3,4,5,6,7,9,10,11,12;), and (IO=2E8h; IRQ=3,4,5,6,7,9,10,11,12;).

Serial Port 2 Configuration Menu

► Serial Port 2 Configuration

Note: It can be "Serial Port 2 Configuration" or "SOL Configuration" based on your system support.

Serial Port 2/SOL ("Serial Port 2" or "SOL" based on your system support)

Select Enabled to enable serial port 2 (or SOL). The options are Disabled and **Enabled**.

Device Settings (Available when "Serial Port 2/SOL" above is set to Enabled)

This feature displays the base I/O port address and the Interrupt Request address of serial port 2 (or SOL).

Change Settings (Available when "Serial Port 2/SOL" above is set to Enabled)

Use this feature to specify the base I/O port address and the Interrupt Request address of serial port 2 (or SOL). Select Auto for the BIOS to automatically assign the base I/O and IRQ address to serial port 2 (or SOL). The options are **Auto**, (IO=2F8h; IRQ=3;), (IO=3F8h; IRQ=3,4,5,6,7,9,10,11,12;), (IO=2F8h; IRQ=3,4,5,6,7,9,10,11,12;), (IO=3E8h; IRQ=3,4,5,6,7,9,10,11,12;), and (IO=2E8h; IRQ=3,4,5,6,7,9,10,11,12;).

Serial Port 2 Attribute (Available for Serial Port 2 only)

Select SOL to use serial port 2 as a Serial Over LAN (SOL) port for console redirection. The options are **SOL** and COM.

Serial Port Console Redirection Menu

► Serial Port Console Redirection

COM1 (Available when your system supports the serial port of COM1)

Console Redirection

Select Enabled to enable COM port 1 for Console Redirection, which allows a client machine to be connected to a host machine at a remote site for networking. The options are **Disabled** and Enabled.

Note: This feature will be set to Enabled if there is no BMC support.

► Console Redirection Settings

Note: This submenu is available when "Console Redirection" for COM1 or SOL/COM2 is set to Enabled.

Terminal Type

Use this feature to select the target terminal emulation type for Console Redirection. Select VT100 to use the ASCII Character set. Select VT100+ to add color and function key support. Select ANSI to use the Extended ASCII Character Set. Select VT-UTF8 to use UTF8 encoding to map Unicode characters into one or more bytes. The options are VT100, **VT100+**, VT-UTF8, and ANSI.

Bits Per Second

Use this feature to set the transmission speed for a serial port used in Console Redirection. Make sure that the same speed is used in the host computer and the client computer. A lower transmission speed may be required for long and busy lines. The options are 9600, 19200, 38400, 57600, and **115200** (bits per second).

Data Bits

Use this feature to set the data transmission size for Console Redirection. The options are 7 and **8** (bits).

Parity

A parity bit can be sent along with regular data bits to detect data transmission errors. Select Even if the parity bit is set to 0, and the number of 1's in data bits is even. Select Odd if the parity bit is set to 0, and the number of 1's in data bits is odd. Select None if you do not want

to send a parity bit with your data bits in transmission. Select Mark to add a mark as a parity bit to be sent along with the data bits. Select Space to add a Space as a parity bit to be sent with your data bits. The options are **None**, Even, Odd, Mark, and Space.

Stop Bits

A stop bit indicates the end of a serial data packet. Select 1 (stop bit) for standard serial data communication. Select 2 (stop bits) if slower devices are used. The options are **1** and **2**.

Flow Control

Use this feature to set the flow control for Console Redirection to prevent data loss caused by buffer overflow. Send a "Stop" signal to stop sending data when the receiving buffer is full. Send a "Start" signal to start sending data when the receiving buffer is empty. The options are **None** and Hardware RTS/CTS.

VT-UTF8 Combo Key Support

Select Enabled to enable VT-UTF8 Combination Key support for ANSI/VT100 terminals. The options are Disabled and **Enabled**.

Recorder Mode

Select Enabled to capture the data displayed on a terminal and send it as text messages to a remote server. The options are **Disabled** and Enabled.

Resolution 100x31

Select Enabled for extended-terminal resolution support. The options are Disabled and **Enabled**.

Putty KeyPad

Use this feature to select function key and keypad settings on Putty, which is a terminal emulator designed for the Windows OS. The options are **VT100**, LINUX, XTERMR6, SCO, ESCN, and VT400.

SOL/COM2

Note: This feature is available when your system supports serial port of SOL and/or COM2. The "SOL/COM2" here indicates a shared serial port, and SOL is used as the default.

Console Redirection

Select Enabled to use the SOL/COM2 port for Console Redirection. The options are Disabled and **Enabled**.

► Console Redirection Settings

Note: This submenu is available when "Console Redirection" for COM1 or SOL/COM2 is set to Enabled.

Terminal Type

Use this feature to select the target terminal emulation type for Console Redirection. Select VT100 to use the ASCII Character set. Select VT100+ to add color and function key support. Select ANSI to use the Extended ASCII Character Set. Select VT-UTF8 to use UTF8 encoding to map Unicode characters into one or more bytes. The options are VT100, **VT100+**, VT-UTF8, and ANSI.

Bits Per Second

Use this feature to set the transmission speed for a serial port used in Console Redirection. Make sure that the same speed is used in the host computer and the client computer. A lower transmission speed may be required for long and busy lines. The options are 9600, 19200, 38400, 57600, and **115200** (bits per second).

Data Bits

Use this feature to set the data transmission size for Console Redirection. The options are 7 and **8** (bits).

Parity

A parity bit can be sent along with regular data bits to detect data transmission errors. Select Even if the parity bit is set to 0 and the number of 1s in data bits is even. Select Odd if the parity bit is set to 0 and the number of 1s in data bits is odd. Select None if you do not want to send a parity bit with your data bits in transmission. Select Mark to add a mark as a parity bit to be sent along with the data bits. Select Space to add a space as a parity bit to be sent with your data bits. The options are **None**, Even, Odd, Mark, and Space.

Stop Bits

A stop bit indicates the end of a serial data packet. Select 1 (stop bit) for standard serial data communication. Select 2 (stop bits) if slower devices are used. The options are **1** and 2.

Flow Control

Use this feature to set the flow control for Console Redirection to prevent data loss caused by buffer overflow. Send a "Stop" signal to stop sending data when the receiving buffer is full. Send a "Start" signal to start sending data when the receiving buffer is empty. The options are **None** and Hardware RTS/CTS.

VT-UTF8 Combo Key Support

Select Enabled to enable VT-UTF8 Combination Key support for ANSI/VT100 terminals. The options are Disabled and **Enabled**.

Recorder Mode

Select Enabled to capture the data displayed on a terminal and send it as text messages to a remote server. The options are **Disabled** and Enabled.

Resolution 100x31

Select Enabled for extended-terminal resolution support. The options are Disabled and **Enabled**.

Putty KeyPad

Use this feature to select function key and keypad settings on Putty, which is a terminal emulator designed for the Windows OS. The options are **VT100**, LINUX, XTERMR6, SCO, ESCN, and VT400.

Serial Port for Out-of-Band Management/Windows Emergency Management Services (EMS)

The feature allows you to configure Console Redirection settings to support Out-of-Band Serial Port management.

Console Redirection EMS

Select Enabled to use the SOL port for Console Redirection. The options are **Disabled** and Enabled.

► Console Redirection Settings

Note: This submenu is available when "Console Redirection EMS" is set to Enabled.

Out-of-Band Mgmt Port

The feature selects a serial port in a client server to be used by the Microsoft Windows Emergency Management Services (EMS) to communicate with a remote host server. The options are **COM1** and SOL/COM2. Please note that the option of SOL/COM2 indicates a shared serial port. SOL is available with BMC support.

Terminal Type EMS

Use this feature to select the target terminal emulation type for Console Redirection. Select VT100 to use the ASCII character set. Select VT100+ to add color and function key support.

Select ANSI to use the extended ASCII character set. Select VT-UTF8 to use UTF8 encoding to map Unicode characters into one or more bytes. The options are VT100, VT100+, **VT-UTF8**, and ANSI.

Bits Per Second EMS

This feature sets the transmission speed for a serial port used in Console Redirection. Make sure that the same speed is used in the host computer and the client computer. A lower transmission speed may be required for long and busy lines. The options are 9600, 19200, 57600, and **115200** (bits per second).

Flow Control EMS

Use this feature to set the flow control for Console Redirection to prevent data loss caused by buffer overflow. Send a "Stop" signal to stop sending data when the receiving buffer is full. Send a "Start" signal to start sending data when the receiving buffer is empty. The options are **None**, Hardware RTS/CTS, and Software Xon/Xoff.

The following information is displayed.

- **Data Bits EMS**
- **Parity EMS**
- **Stop Bits EMS**

Network Stack Configuration Menu

► Network Stack Configuration

Network Stack

Select Enabled to enable Preboot Execution Environment (PXE) or Unified Extensible Firmware Interface (UEFI) for network stack support. The options are Disabled and **Enabled**.

IPv4 PXE Support (Available when "Network Stack" is set to Enabled)

Select Enabled to enable IPv4 PXE boot support. If this feature is disabled, it will not create the IPv4 PXE boot option. The options are Disabled and **Enabled**.

IPv4 HTTP Support (Available when "Network Stack" is set to Enabled)

Select Enabled to enable IPv4 HTTP boot support. If this feature is disabled, it will not create the IPv4 HTTP boot option. The options are **Disabled** and Enabled.

IPv6 PXE Support (Available when "Network Stack" is set to Enabled)

Select Enabled to enable IPv6 PXE boot support. If this feature is disabled, it will not create the IPv6 PXE boot option. The options are Disabled and **Enabled**.

IPv6 HTTP Support (Available when "Network Stack" is set to Enabled)

Select Enabled to enable IPv6 HTTP boot support. If this feature is disabled, it will not create the IPv6 HTTP boot option. The options are **Disabled** and Enabled.

PXE Boot Wait Time (Available when "Network Stack" is set to Enabled)

Use this feature to set the wait time (in seconds) upon which the system BIOS will wait for you to press the <ESC> key to abort PXE boot instead of proceeding with PXE boot by connecting to a network server immediately. Press the <+> or <-> key on your keyboard to change the value. The default setting is **0**.

Media Detect Count (Available when "Network Stack" is set to Enabled)

Use this feature to set the wait time (in seconds) for the BIOS ROM to detect the presence of a LAN media either via the Internet connection or via a LAN port. Press the <+> or <-> key on your keyboard to change the value. The default setting is **1**.

MAC:(MAC address)-IPv4 Network Configuration Menu**▶ MAC:(MAC address)-IPv4 Network Configuration****Configured**

Enable this feature to configure network addresses for DHCP, local IP address, local netmask, local gateway, and local DNS server. The options are **Disabled** and Enabled.

Enable DHCP (Available when "Configured" is set to Enabled)

Select Enabled to support Dynamic Host Configuration Protocol (DHCP), which allows the BIOS to search for a DHCP server attached to the network and request the next available IP address for this computer. The options are **Disabled** and Enabled.

Local IP Address (Available when "Configured" is set to Enabled and "Enable DHCP" is set to Disabled)

Use this feature to enter an IP address for the local machine.

Local NetMask (Available when "Configured" is set to Enabled and "Enable DHCP" is set to Disabled)

Use this feature to set the netmask for the local machine.

Local Gateway (Available when "Configured" is set to Enabled and "Enable DHCP" is set to Disabled)

Use this feature to set the gateway address for the local machine.

Local DNS Servers (Available when "Configured" is set to Enabled and "Enable DHCP" is set to Disabled)

Use this feature to set the Domain Name System (DNS) server address for the local machine.

Save Changes and Exit

Press <Enter> to save changes and exit.

MAC:(MAC address)-IPv6 Network Configuration Menu

▶ MAC:(MAC address)-IPv6 Network Configuration

▶ Enter Configuration Menu

The following information is displayed.

- Interface Name
- Interface Type
- MAC address
- Host address
- Route Table
- Gateway addresses
- DNS addresses

Interface ID

Use this feature to change/enter the 64-bit alternative interface ID for the device. The string format is colon separated. The default setting is the MAC address above.

DAD Transmit Count

Use this feature to set the number of consecutive neighbor solicitation messages that have been sent while performing duplicate address detection on a tentative address. The default setting is **1**.

Policy

Use this feature to select how the policy is to be configured. The options are **automatic** and manual.

▶ Advanced Configuration

Note: This submenu is available when "Policy" is set to manual.

New IPv6 address: Use this feature to enter the IPv6 address for the local machine.

New Gateway addresses: Use this feature to set the gateway address for the local machine.

New DNS addresses: Use this feature to set the DNS server address for the local machine.

Commit Changes and Exit: Press <Enter> to save changes and exit.

Discard Changes and Exit: Press <Enter> to discard changes and exit.

Save Changes and Exit

Press <Enter> to save changes and exit.

PCIe/PCI/PnP Configuration Menu

► PCIe/PCI/PnP Configuration

The following information is displayed.

- PCI Bus Driver Version

PCI Devices Common Settings:

Re-Size BAR Support

Use this feature to enable the Resizable BAR support. Resizable BAR is a PCIe interface technology that allows the CPU to access the entire frame buffer. With this technology, your system will be able to handle multiple CPU to GPU transfers simultaneously rather than queuing, which can improve the frame rate performance. The options are **Disabled** and **Enabled**.

SR-IOV Support

Select **Enabled** for Single-Root IO Virtualization support. The options are **Disabled** and **Enabled**.

ARI Support

Select **Enabled** for Alternative Routing-ID Interpretation (ARI) support. The options are **Disabled** and **Enabled**.

MMIO High Base

Use this feature to select the base memory size according to memory-address mapping for the I/O hub. The options are 248T, 120T, 88T, 60T, 30T, 56T, 40T, 32T, 24T, 16T, 4T, 2T, 1T, 512G, 3584T, and **Auto**. The options of 248T, 120T, 88T, 60T, 30T, and 3584T are CPU-dependent.

MMIO High Granularity Size

Use this feature to select the high memory size according to memory-address mapping for the I/O hub. The options are 1G, 4G, 16G, 32G, 64G, 256G, and **1024G**. This feature is motherboard-dependent.

Bus Master Enable

If this feature is set to Enabled, the PCI Bus Driver will enable the Bus Master Attribute for DMA transactions. If this feature is set to Disabled, the PCI Bus Driver will disable the Bus Master Attribute for Pre-Boot DMA protection. The options are Disabled and **Enabled**.

NVMe Firmware Source

Use this feature to select the NVMe firmware to support system boot. The options are Vendor Defined Firmware and **AMI Native Support**. The option of Vendor Defined Firmware is pre-installed on the drive and may resolve errata or enable innovative functions for the drive. The default option, AMI Native Support, is offered by the BIOS with a generic method.

VGA Priority

Use this feature to select the graphics device to be used as the primary video display for system boot. The options are **Onboard** and Offboard.

Onboard Video Option ROM

Select EFI to boot the computer using the Extensible Firmware Interface (EFI) device installed on the onboard video port. The options are Disabled and **EFI**.

AOC-ATG-i2S LAN1 OPROM / Onboard SAS Option ROM / Onboard LAN1 Option ROM / Onboard NVMe1 Option ROM – Onboard NVMe24 Option ROM

Select EFI to allow you to boot the computer using the EFI device installed on the PCIe slot specified. The options are Disabled and **EFI**.

Note: The number of slots and slot naming vary based on your motherboard features.

HTTP Boot Configuration Menu

► HTTP Boot Configuration

HTTP Boot Policy

Use this feature to set the HTTP boot policy. The options are Apply to all LANs, **Apply to each LAN**, and Boot Priority #1 instantly.

HTTPS Boot Checks Hostname

Important: Disabling "HTTPS Boot Checks Hostname" is a violation of RFC 6125 and may expose you to Man-in-the-Middle Attacks. Supermicro is not responsible for any and all security risks incurred by you disabling this feature.

Enable this feature for HTTPS boot to check the hostname of the TLS certificates to see if it matches the host name provided by the remote server. The options are **Enabled** and Disabled (WARNING: Security Risk!!).

Priority of HTTP Boot

Instance of Priority 1: (Available when your motherboard supports this feature)

This feature sets the rank target port. The default setting is **1**.

Select IPv4 or IPv6

This feature specifies which connection the target LAN port should boot from. The options are **IPv4** and IPv6.

Boot Description

Use this feature to enter a boot description, which cannot be longer than 75 characters. Please be sure to enter a boot description; otherwise, the boot option for the URI cannot be created.

Boot URI

Enter a Boot Uniform Research Identifier (URI) with 128 characters or shorter. This Boot URI determines how IPv4 Boot Option and IPv6 Boot Option will be created.

Instance of Priority 2: (Available when your motherboard supports this feature)

This feature sets the rank target port. The default setting is **0**.

Select IPv4 or IPv6 (Unavailable when "Instance of Priority 2:" above is set to 0)

This feature specifies which connection the target LAN port should boot from. The options are **IPv4** and IPv6.

Boot Description (Unavailable when "Instance of Priority 2:" above is set to 0)

Use this feature to enter a boot description, which cannot be longer than 75 characters. Please be sure to enter a boot description; otherwise, the boot option for the URI cannot be created.

Boot URI (Unavailable when "Instance of Priority 2:" above is set to 0)

Enter a Boot URI with 128 characters or shorter. This Boot URI determines how IPv4 Boot Option and IPv6 Boot Option will be created.

Supermicro KMS Server Configuration Menu

► Supermicro KMS Server Configuration

Note: Be sure to configure all the features in the submenu of Supermicro KMS Server Configuration and the feature of "KMS Security Policy" in the submenu of Super-Guardians Configuration so that your system can communicate with the KMS server.

Supermicro KMS Server IP address

Use this feature to set the Supermicro Key Management Service (KMS) server IPv4 address in dotted-decimal notation.

Second Supermicro KMS Server IP address

Use this feature to set the second Supermicro KMS server IPv4 address in dotted-decimal notation.

Supermicro KMS TCP Port number

Use this feature to set the TCP port number used in the Supermicro KMS server. The valid range is 100–9999. The default setting is **5696**. Do not change the default setting unless a different TCP port number has been specified and used in the Supermicro KMS server.

KMS Time Out

Use this feature to enter the KMS server connecting time-out (in seconds). The default setting is **5** (seconds).

TimeZone

Use this feature to set the correct time zone. The default setting is **0** (not specified).

Client UserName

Press <Enter> to set the client identity (UserName). The length is 0–63 characters.

Client Password

Press <Enter> to set the client identity (Password). The length is 0–31 characters.

▶ CA Certificate**▶ Client Certificate****▶ Client Private Key**

Use the three features above to enroll factory defaults or load the KMS Transport Layer Security (TLS) certificates, which are generated by the KMS server, from the file stored in the USB flash drive as shown below.

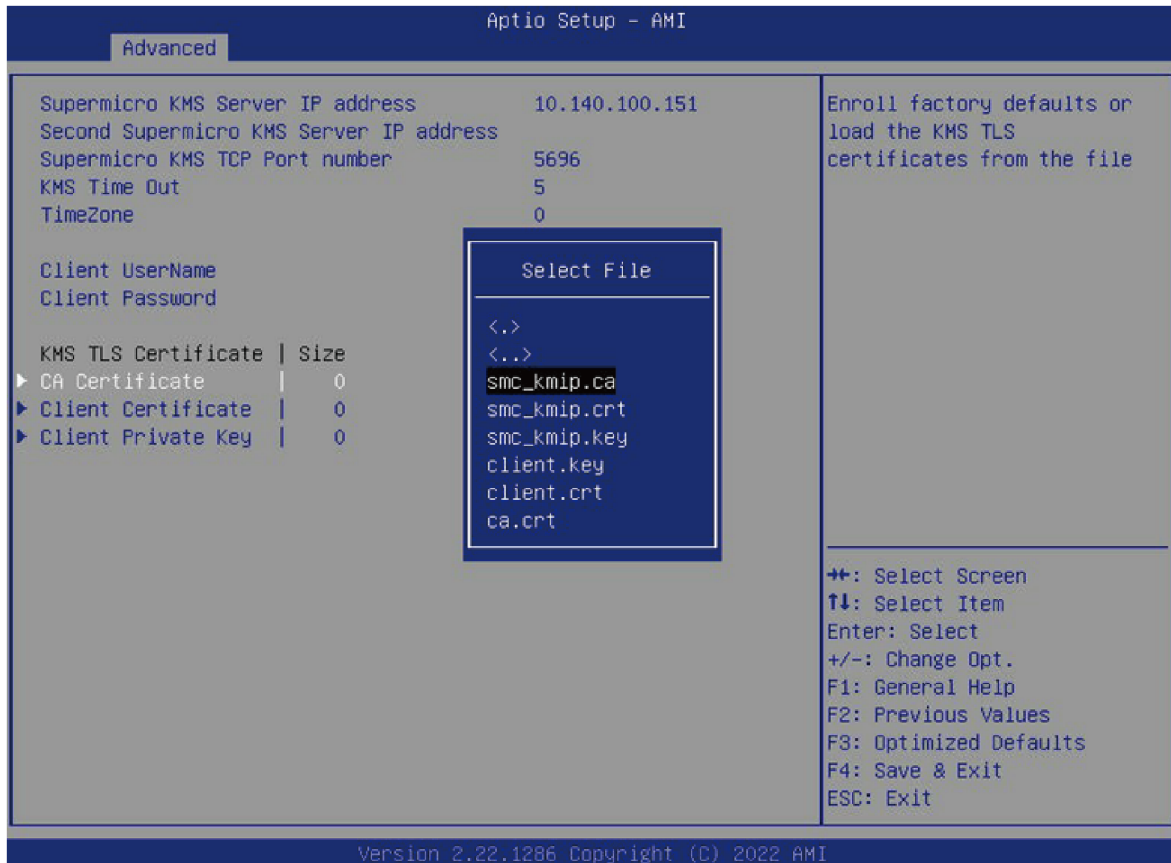

Private Key Password (Available when "Client Private Key" above has been set)

Use this feature to change the private key password.

Super-Guardians Configuration Menu

► Super-Guardians Configuration

Super-Guardians Protection Policy

Use this feature to enable the Super-Guardians Protection Policy. The options are **Storage**, **System**, and **System and Storage**. Set this feature to **Storage** to protect and have secure access to the Trusted Computing Group (TCG) NVMe devices with the Authentication-Key (AK). Set this feature to **System** to protect and have secure access to your system/motherboard with the AK. Set this feature to **System and Storage** to protect and have secure access to your system/motherboard/storage devices with the AK.

KMS Security Policy (Available when "TPM Security Policy" and "USB Security Policy" are set to Disabled)

Set this feature to **Enabled** to enable the KMS Security Policy. When this feature has not previously been set to **Enabled**, the options are **Disabled** and **Enabled**. Changes take effect after you save settings and reboot the system.

When this feature has previously been set to Enabled, the options are **Enabled**, Reset, and Key Rotation. Set this feature to Key Rotation to obtain an existing AK from the KMS server and create a new AK. To disable the KMS Security Policy, set this feature to Reset. When this feature is set to Reset, the system and TCG NVMe devices chosen in "Super-Guardians Protection Policy" will be in the unprotected mode.

Notes:

- Be sure that the KMS server is ready before configuring this feature.
- Use the professional KMS server solutions (e.g., Thales Server) or the Supermicro PyKMIP Software Package to establish the KMS server.

KMS Server Retry Count (Available when "TPM Security Policy" and "USB Security Policy" are set to Disabled)

Use this feature to specify how many times the system will attempt reconnecting to the KMS server. The valid range is 0–10. Press the <+> or <-> key on your keyboard to change the value. The default setting is 5. If the value is 0, the system will retry infinitely.

TPM Security Policy (Available when "KMS Security Policy" and "USB Security Policy" are set to Disabled)

Set this feature to Enabled to enable the TPM Security Policy. When this feature has not previously been set to Enabled, the options are **Disabled** and Enabled. Changes take effect after you save settings and reboot the system.

When this feature has previously been set to Enabled, the options are **Enabled** and Reset. To disable the TPM Security Policy, set this feature to Reset. When this feature is set to Reset, the system and TCG NVMe devices chosen in "Super-Guardians Protection Policy" will be in the unprotected mode.

Load Authentication-Key (Available when "KMS Security Policy," "TPM Security Policy," and "USB Security Policy" are set to Disabled)

The options are **Disabled** and Enabled. Set this feature to Enabled. Changes take effect after you save settings and reboot the system. While booting, the BIOS will automatically load the Authentication-Key (filename: TPMAuth.bin) from the USB flash drive. Afterwards, the default setting will be set to Disabled by the BIOS.

Notes:

- Be sure to connect a USB flash drive with the Authentication-Key (filename: TPMAuth.bin) to your system before the system reboot.
- Be sure to save the Authentication-Key (filename: TPMAuth.bin) to the USB flash drive and keep a backup. Load the Authentication-Key (filename: TPMAuth.bin) after the TPM (either onboard or external) is detected by your system. Otherwise, the TPM function can not work properly.

Save Authentication-Key (Available when "TPM Security Policy" is set to Enabled)

The options are **Disabled** and Enabled. Set this feature to Enabled. Changes take effect after you save settings and reboot the system. While booting, the BIOS will automatically save the Authentication-Key (filename: TPMAuth.bin) to the USB flash drive. Afterwards, the default setting will be set to Disabled by the BIOS.

Note: Be sure to connect a USB flash drive to your system before the system reboot.

USB Security Policy (Available when "KMS Security Policy" and "TPM Security Policy" are set to Disabled)

Use this feature to enable the USB Security Policy. The options are **Disabled** and Enabled. Set this feature to Enabled. Changes take effect after you save settings and reboot the system. Connect a USB flash drive to your system before the system reboot. While booting, the BIOS will automatically create the USB Authentication-Key (filename: USBAuth.bin) and save it to the USB flash drive.

When this feature has been previously set to Enabled, the options are **Enabled** and Reset. To disable the USB Security Policy, set this feature to Reset. When this feature is set to Reset, the system and TCG NVMe devices chosen in "Super-Guardians Protection Policy" will be in the unprotected mode.

Note: Be sure to connect a USB flash drive to your system before configuring this feature. Save the USB Authentication-Key (filename: USBAuth.bin) to the USB flash drive and keep a backup.

TLS Authenticate Configuration Menu

► TLS Authenticate Configuration

Use this submenu to configure Transport Layer Security (TLS) settings.

▶ Server CA Configuration

Use this feature to configure the client certificate that is to be used by the server.

▶ Enroll Certification

Use this feature to enroll the certificate in the system.

▶ Enroll Certification Using File

Use this feature to enroll the security certificate in the system by using a file.

▶ Commit Changes and Exit

Use this feature to save all changes and exit TLS settings.

▶ Discard Changes and Exit

Use this feature to discard all changes and exit TLS settings.

▶ Delete Certification

Use this feature to delete the certificate if a certificate has been enrolled in the system.

▶ Client Certification Configuration

Driver Health Menu

▶ Driver Health

This feature displays the health information of the drivers installed in your system, including LAN controllers, as detected by the BIOS. Select one and press <Enter> to see the details.

Note: This section is provided for reference only, for the driver health status will differ depending on the drivers installed in your system. It's also based on your system configuration and the environment that your system is operating in.

4.4 Event Logs

Use this menu to configure Event Logs settings.

Note: After making any changes in this section, please be sure to reboot the system for the changes to take effect.

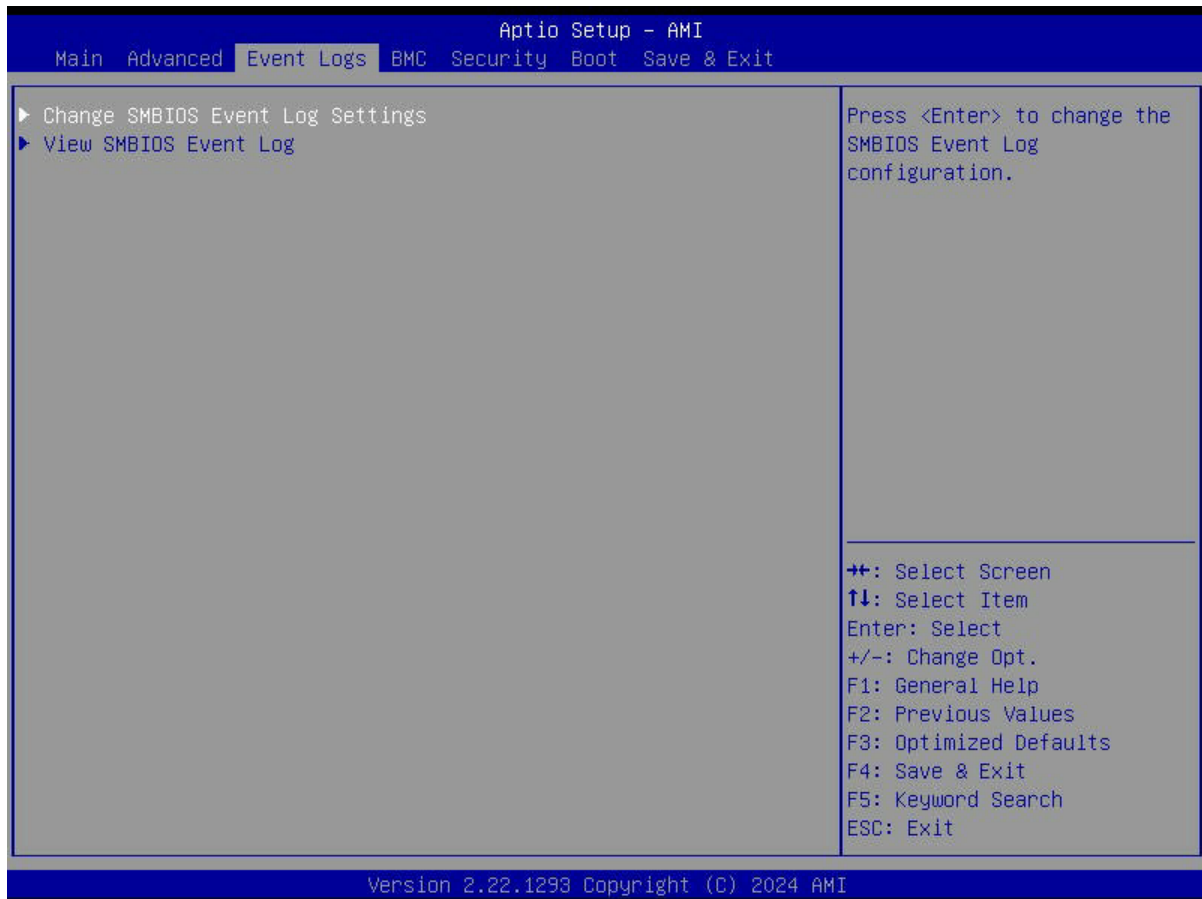

Figure 4-3. Event Logs Screen

▶ Change SMBIOS Event Log Settings

Note: Reboot the system for the changes in this section to take effect.

Enabling/Disabling Options

SMBIOS Event Log

Select Enabled to enable System Management BIOS (SMBIOS) Event Logging during system boot. The options are Disabled and **Enabled**.

Erasing Settings

Erase Event Log (Available when "SMBIOS Event Log" is set to Enabled)

Select No to keep the event log without erasing it upon next system bootup. Select (Yes, Next reset) to erase the event log upon next system reboot. The options are **No**, (Yes, Next reset), and (Yes, Every reset).

When Log is Full (Available when "SMBIOS Event Log" is set to Enabled)

Select Erase Immediately to immediately erase all errors in the SMBIOS event log when the event log is full. Select Do Nothing for the system to do nothing when the SMBIOS event log is full. The options are **Do Nothing** and Erase Immediately.

SMBIOS Event Log Standard Settings

Log System Boot Event (Available when "SMBIOS Event Log" is set to Enabled)

Select Enabled to log system boot events. The options are Enabled and **Disabled**.

MECI (Available when "SMBIOS Event Log" is set to Enabled)

Enter the increment value for the multiple event counter. Enter a number between 1 and 255. The default setting is 1. (MECI is the abbreviation for Multiple Event Count Increment.)

METW (Available when "SMBIOS Event Log" is set to Enabled)

Use this feature to determine how long (in minutes) should the multiple event counter wait before generating a new event log. Enter a number between 0 and 99. The default value is **60**. (METW is the abbreviation for Multiple Event Count Time Window.)

► View SMBIOS Event Log

Use this feature to view the event in the system event log. Select this feature and press <Enter> to view the status of an event in the log. The following information is displayed: DATE / TIME / ERROR CODE / SEVERITY.

4.5 BMC

Use this menu to configure Baseboard Management Console (BMC) settings.

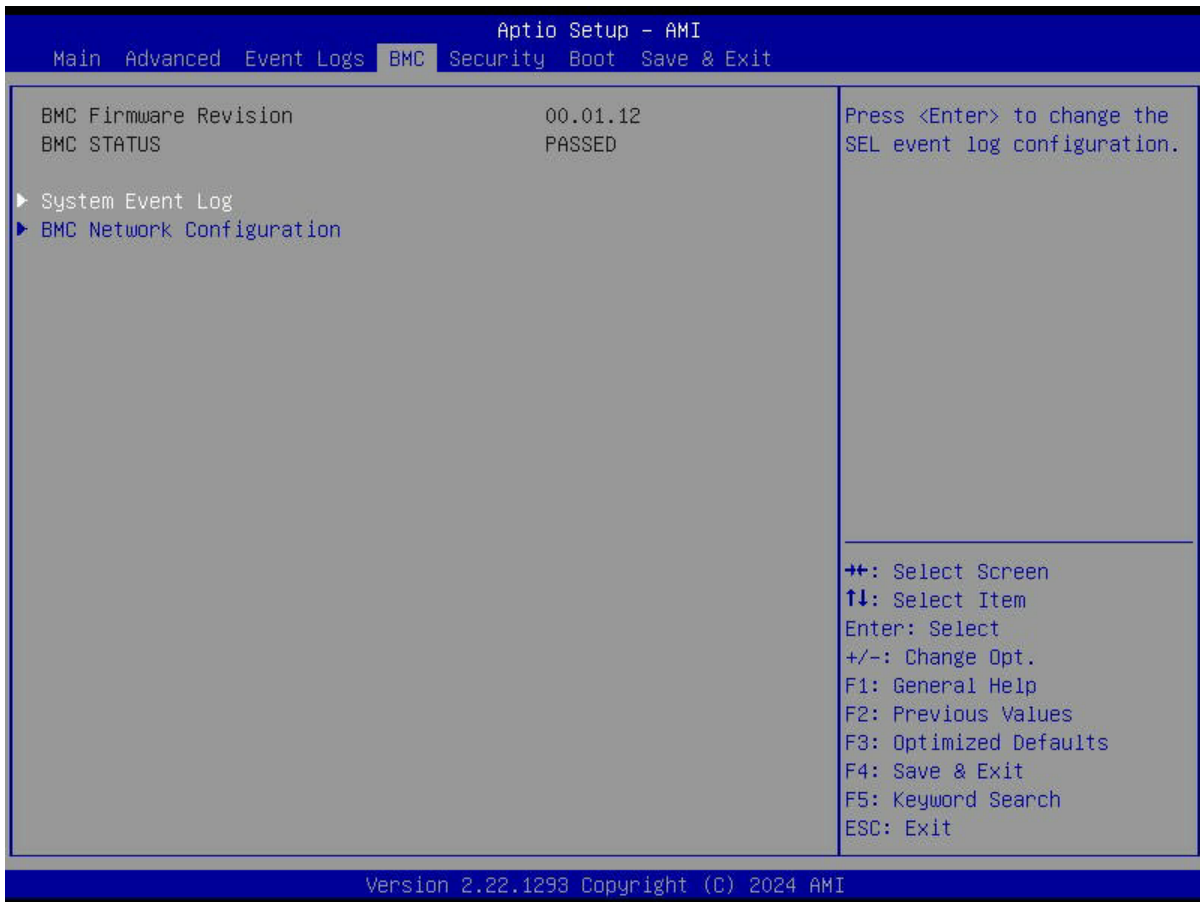

Figure 4-4. BMC Screen

BMC Firmware Revision

This feature indicates the BMC firmware revision used in this system.

BMC STATUS

This feature indicates the status of the BMC firmware installed in this system.

System Event Log Menu

▶ System Event Log

Note: All values changed in this submenu do not take effect until computer is restarted.

Enabling/Disabling Options

SEL Components

Select Enabled to enable all system event logging upon system boot. The options are Disabled and **Enabled**.

Erasing Settings

Erase SEL (Available when "SEL Components" is set to Enabled)

Select (Yes, On next reset) to erase all system event logs upon next system boot. Select (Yes, On every reset) to erase all system event logs upon each system reboot. Select No to keep all system event logs after each system reboot. The options are **No**, (Yes, On next reset), and (Yes, On every reset).

When SEL is Full (Available when "SEL Components" is set to Enabled)

This feature defines what the BIOS should do when the system event log is full. Select Erase Immediately to erase all events in the log when the system event log is full. The options are **Do Nothing** and Erase Immediately.

BMC Network Configuration Menu

► BMC Network Configuration

Update BMC LAN Configuration

Select Yes for the BIOS to implement all IP/MAC address changes upon next system boot. The options are **No** and Yes.

Configure IPv4 Support

BMC LAN Selection

This feature displays the type of the BMC LAN.

BMC Network Link Status:

This feature displays the status of the BMC network link for this system.

Configuration Address Source (Available when "Update BMC LAN Configuration" is set to Yes)

Use this feature to select the source of the IPv4 connection. If Static is selected, note the IP address of the IPv4 connection and enter it to the system manually in the field. If DHCP is

selected, the BIOS will search for a Dynamic Host Configuration Protocol (DHCP) server in the network that is attached to and request the next available IP address for this computer. The options are Static and **DHCP**.

Station IP Address

This feature displays the Station IP address in decimal and in dotted quad form (i.e., 172.29.176.131). It is available for configuration when "Configuration Address Source" above is set to Static.

Subnet Mask

This feature displays the sub-network that this computer belongs to. It is available for configuration when "Configuration Address Source" above is set to Static.

Station MAC Address

This feature displays the Station MAC address for this computer. MAC addresses are six two-digit hexadecimal numbers.

Gateway IP Address

This feature displays the Gateway IP address for this computer. This should be in decimal and in dotted quad form (i.e., 172.29.0.1). It is available for configuration when "Configuration Address Source" above is set to Static.

Configure IPv6 Support

IPv6 Address Status

This feature displays the status of the IPv6 address.

IPv6 Support (Available when "Update BMC LAN Configuration" is set to Yes)

Use this feature to enable IPv6 support. The options are **Enabled** and Disabled.

Configuration Address Source (Available when "IPv6 Support" is set to Enabled)

Use this feature to select the source of the IPv6 connection. If Static Configuration is selected, note the IP address of IPv6 connection and enter it to the system manually in the field. If the other two options are selected, the BIOS will search for a DHCP server in the network that is attached to and request the next available IP address for this computer. The options are Static Configuration, **DHCPv6 Stateless**, and DHCPv6 Stateful.

IPv6 Address ("Static," "DHCPv6 Stateless," or "DHCPv6 Stateful," depending on the option you selected for "Configuration Address Source" above)

This feature displays the station IPv6 address. It is available for configuration when "Configuration Address Source" above is set to Static Configuration.

Prefix Length

This feature displays the prefix length. It is available for configuration when "Configuration Address Source" above is set to Static Configuration.

Gateway IP

This feature displays the IPv6 gateway IP address. It is available for configuration when "Configuration Address Source" above is set to Static Configuration.

Advanced Settings (Available when "Configuration Address Source" is set to DHCPv6 Stateless)

Use this feature to set the DNS server IP. The default setting allows this system to obtain the DNS server IP automatically. The options are **Auto obtain DNS server IP** and Manually obtain DNS server IP.

Preferred DNS server IP (Available when "Advanced Settings" above is set to Manually obtain DNS server IP)

This feature displays the preferred DNS server IP. It can be configured via Redfish.

Alternative DNS server IP (Available when "Advanced Settings" above is set to Manually obtain DNS server IP)

This feature displays the alternative DNS server IP. It can be configured via Redfish.

Configure VLAN Support

Lan channel 1**VLAN Support (Available when "Update BMC LAN Configuration" is set to Yes)**

Use this feature to enable the virtual LAN (VLAN) support. The options are Enabled and Disabled.

VLAN ID (Available when "VLAN Support" is set to Enabled)

Use this feature to create a new VLAN ID. The valid range is 1–4094. The default setting is 1.

4.6 Security

Use this menu to configure the following security settings for the system.

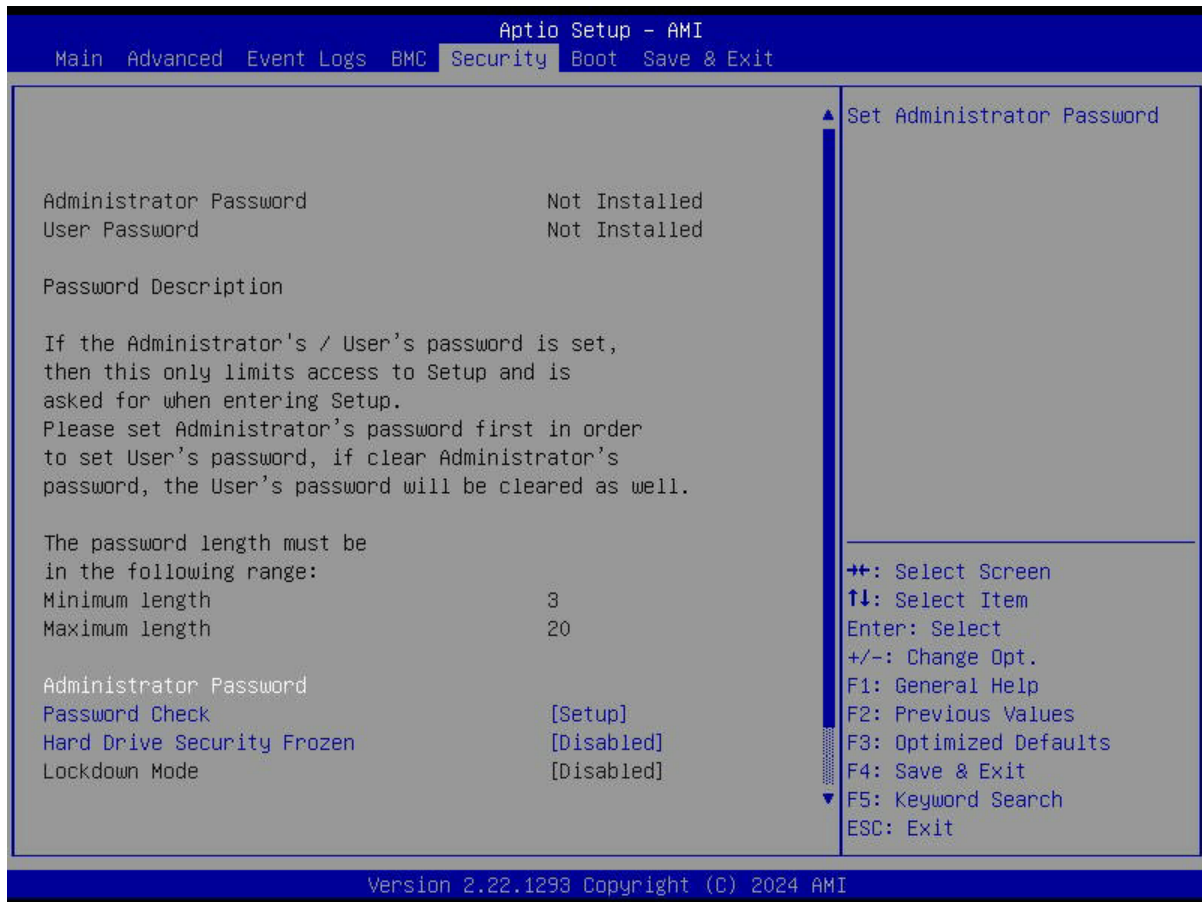

Figure 4-5. Security Screen

Disable Block Sid and Freeze Lock (Available when your storage devices support TCG)

Select Enabled to allow SID authentication to be performed in TCG storage devices. The options are **Disabled** and Enabled.

The following information is displayed:

- Administrator Password
- User Password
- Password Description

Administrator Password

This feature indicates if an administrator password has been installed. Use this feature to set the administrator password, which is required to enter the BIOS Setup utility. The length of the password can be between three and 20 characters long.

User Password (Available when "Administrator Password" has been set)

This feature indicates if a user password has been installed. Use this feature to set the user password which is required to enter the BIOS Setup utility. The length of the password can be between three and 20 characters long.

Password Check

Select Setup for the system to check for a password upon entering the BIOS Setup utility. Select Always for the system to check for the passwords needed at bootup and upon entering the BIOS Setup utility. The options are **Setup** and Always.

Hard Drive Security Frozen

Select Enabled to freeze the Lock Security feature for HDD to protect key data in hard drives from being altered. The options are **Disabled** and Enabled.

Lockdown Mode (Available when the DCMS key is activated)

Select Enabled to support the Lockdown Mode, which prevents the existing data or keys stored in the system from being altered or changed in an effort to preserve system integrity and security. The options are **Disabled** and Enabled.

Secure Boot Menu

► Secure Boot

The following information is displayed:

- System Mode
- Secure Boot

Note: For detailed instructions on configuring Security Boot settings, refer to the Security Boot Configuration User's Guide at <https://www.supermicro.com/support/manuals>.

Secure Boot

Select Enabled to configure Secure Boot settings. The options are **Disabled** and Enabled.

Secure Boot Mode

Use this feature to select the desired secure boot mode for the system. The options are Standard and **Custom**.

► Enter Audit Mode

Select Ok to enter the Audit Mode workflow. It will result in erasing the Platform Key (PK) variables and resetting the system to the Setup/Audit Mode.

Note: This submenu is available when "Secure Boot Mode" is set to Custom.

▶ Key Management

The following information is displayed:

- Vendor Keys

Note: This submenu is available when "Secure Boot Mode" is set to Custom.

Provision Factory Defaults

Select Enabled to install provision factory default settings after a platform reset while the system is in the Setup Mode. The options are **Disabled** and Enabled.

▶ Restore Factory Keys

Select Yes to restore manufacturer default keys to ensure system security. The options are **Yes** and No. Selecting Yes will reset system to the User Mode.

Note: This submenu is available when any secure keys have been installed.

▶ Reset To Setup Mode

This feature resets the system to the Setup Mode. The options are **Yes** and No.

Note: This submenu is available when any secure keys have been installed.

▶ Enroll Efi Image

This feature allows the Efi image to run in the secure boot mode and enroll the SHA256 Hash certificate of a PE image into the Authorized Signature Database (DB).

▶ Export Secure Boot Variables

This feature exports the NVRAM contents of secure boot variables to a storage device. The options are **Yes** and No.

Note: This submenu is available when any secure keys have been installed.

Secure Boot variable / Size / Keys / Key Source

▶ Platform Key (PK)

Use this feature to enter and configure a set of values to be used as platform firmware keys for the system. These values also indicate the sizes, key numbers, and the sources of the authorized signatures. Select Update to update the platform key.

▶ Key Exchange Keys (KEK)

Use this feature to enter and configure a set of values to be used as Key Exchange Keys for the system. These values also indicate the sizes, key numbers, and the sources of the authorized signatures. Select Update to update the Key Exchange Keys. Select Append to append the Key Exchange Keys.

▶ Authorized Signatures (db)

Use this feature to enter and configure a set of values to be used as Authorized Signatures for the system. These values also indicate the sizes, key numbers, and sources of the authorized signatures. Select Update to update the Authorized Signatures. Select Append to append the new Authorized Signatures.

▶ Forbidden Signatures (dbx)

Use this feature to enter and configure a set of values to be used as Forbidden Signatures for the system. These values also indicate sizes, key numbers, and key sources of the forbidden signatures. Select Update to update the Forbidden Signatures. Select Append to append the Forbidden Signature.

▶ Authorized TimeStamps (dbt)

Use this feature to set and save the timestamps for the Authorized Signatures, which will indicate the time when these signatures are entered into the system. These values also indicate sizes, keys, and key sources of the authorized timestamps. Select Update to update the Authorized TimeStamps. Select Append to append the Authorized TimeStamps.

▶ OsRecovery Signatures (dbr)

Use this feature to set and save the Authorized Signatures used for OS recovery. Select Update to update the OsRecovery Signatures. These values also indicate sizes, keys, and key sources of the OsRecovery Signatures. Select Append to append the OsRecovery Signatures.

4.7 Boot

Use this menu to configure Boot settings.

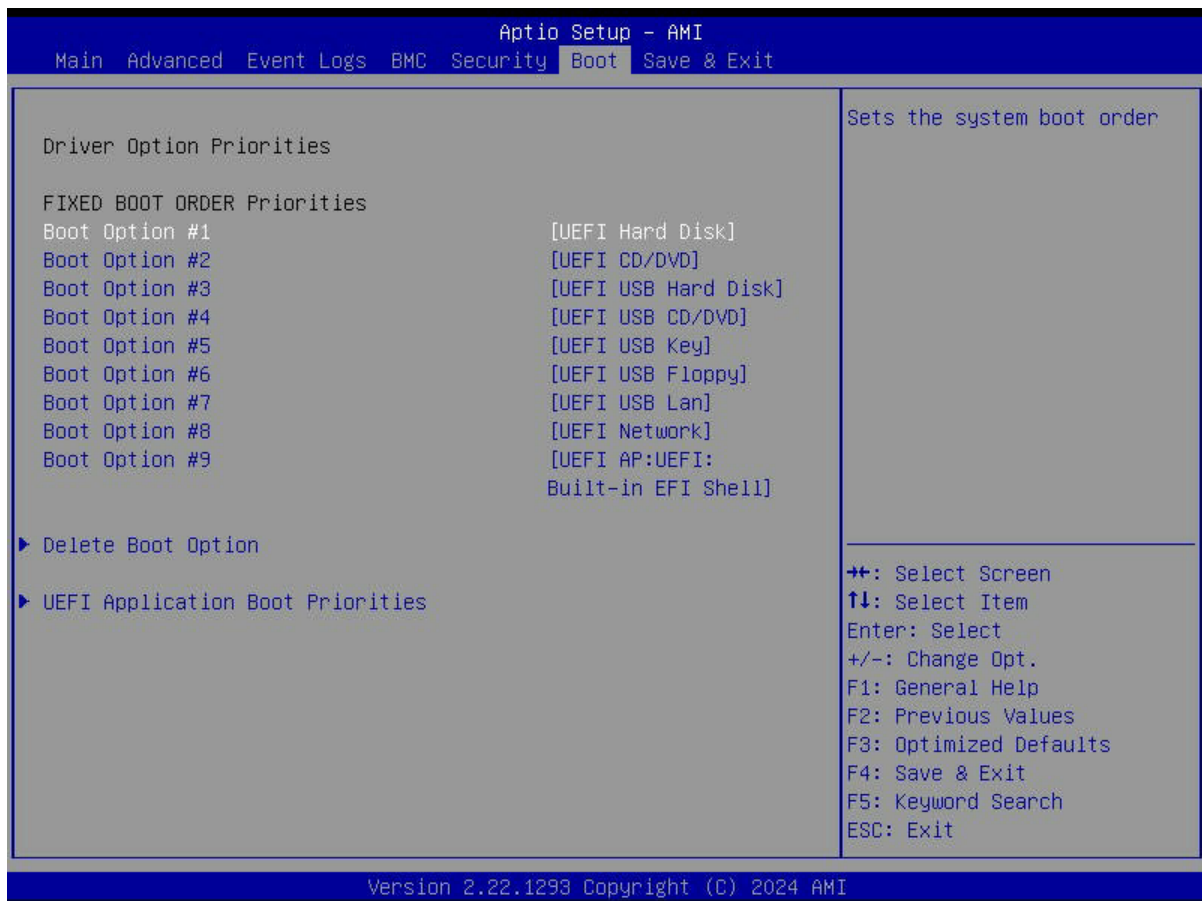

Figure 4-6. Boot Screen

Driver Option Priorities

FIXED BOOT ORDER Priorities

Use this feature to prioritize the order of a bootable device from which the system will boot. Press <Enter> on each item sequentially to select the device.

- Boot Option #1 – Boot Option #9

► Add New Boot Option

Use this feature to add a new boot option to the boot priority features for system boot.

Note: This submenu is available when any storage device is detected by the BIOS.

Add boot option

Use this feature to specify the name for the new boot option.

Path for boot option

Use this feature to enter the path for the new boot option in the format fsx:\path\filename.efi.

Boot option File Path

Use this feature to specify the file path for the new boot option.

Create

After setting the name and the file path for the boot option, press <Enter> to create the new boot option in the boot priority list.

► Delete Boot Option

Use this feature to select a boot device to delete from the boot priority list.

Delete Boot Option

Use this feature to remove an EFI boot option from the boot priority list.

► UEFI Application Boot Priorities

Use this feature to set the system boot order of detected devices.

4.8 Save & Exit

Select Save & Exit from the BIOS Setup screen to configure the settings below.

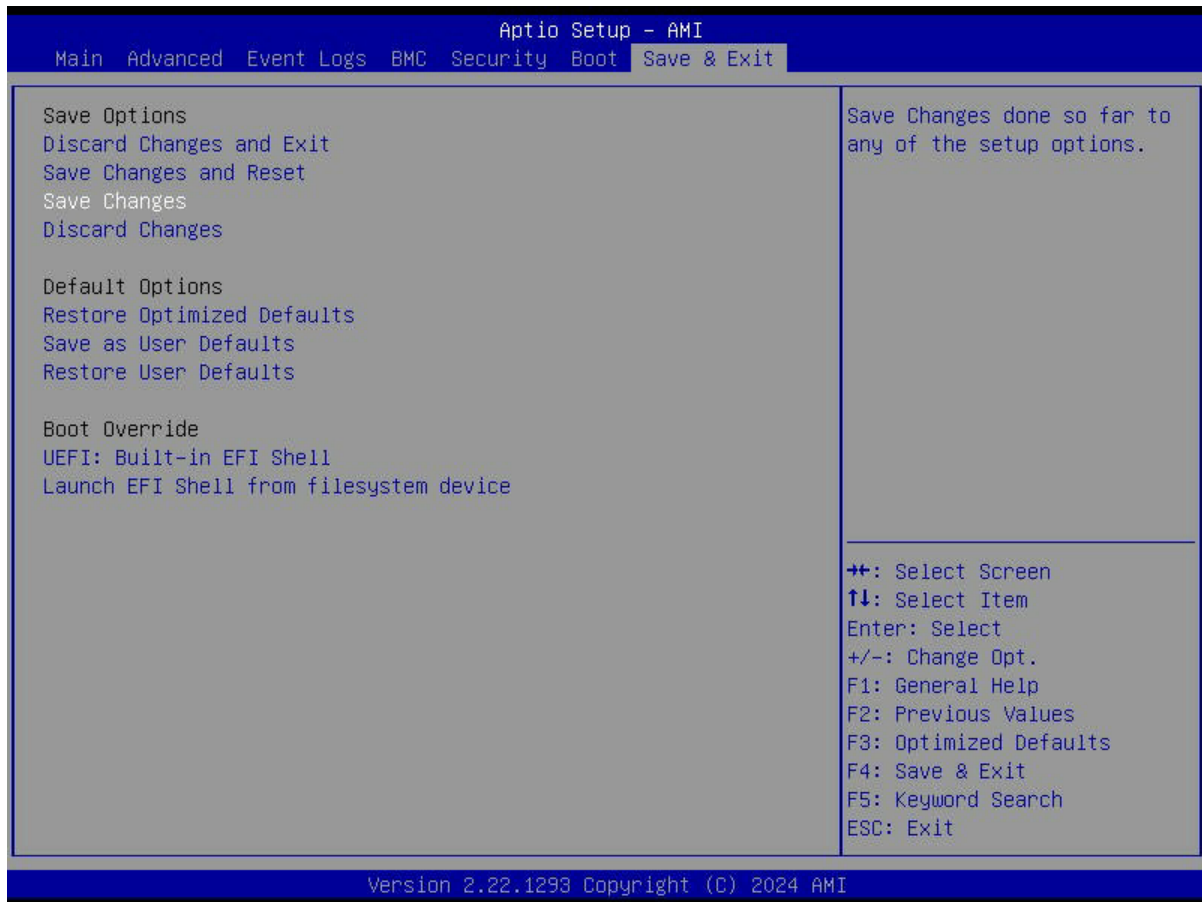

Figure 4-7. Save & Exit Screen

Save Options

Discard Changes and Exit

Use this feature to exit from the BIOS Setup utility without making any permanent changes to the system configuration and reboot the computer.

Save Changes and Reset

On completing the system configuration changes, use this feature to exit the BIOS Setup utility and reboot the computer for the new system configuration parameters to take effect.

Save Changes

On completing the system configuration changes, use this feature to save all changes made. This will not reset (reboot) the system.

Discard Changes

Select this feature and press <Enter> to discard all changes made and return to the BIOS Setup utility.

Default Options**Restore Optimized Defaults**

Select this feature and press <Enter> to load manufacturer optimized default settings, which are intended for maximum system performance but not for maximum stability.

Note: After pressing <Enter>, reboot the system for the changes to take effect, which ensures that this system has the optimized default settings.

Save as User Defaults

Select this feature and press <Enter> to save all changes as the default values specified to the BIOS Setup utility for future use.

Restore User Defaults

Select this feature and press <Enter> to retrieve user-defined default settings that have been saved previously.

Boot Override

Note: Use this section to override the Boot priorities sequence in the Boot menu, and immediately boot the system with a device specified here instead of the one specified in the boot list. This is a one-time boot override.

Launch EFI Shell from filesystem device

Use this feature to launch the EFI shell application (Shell.efi) from one of the available filesystem devices. A filesystem is a virtual, logical, or physical system for organizing, managing, and accessing the files and directories on devices such as SSDs, HDDs, or other storage devices.

Appendix A:

Software

After the X14DBM-SP motherboard has been installed, you can install the Operating System (OS), configure RAID settings, and install the drivers.

Microsoft Windows OS Installation

If you will be using RAID, you must configure RAID settings before installing the Windows OS and the RAID driver. Refer to the RAID Configuration User Guides posted on our website at <https://www.supermicro.com/support/manuals>.

Installing the OS

1. Create a method to access the Microsoft Windows installation ISO file. That can be a USB flash or media drive, or the BMC KVM console.
2. Retrieve the proper drivers. Go to the Supermicro web page for your motherboard and click on "Download the Latest Drivers and Utilities," select the proper driver, and copy it to a USB flash drive.
3. Boot from a bootable device with Windows OS installation. You can see a bootable device list by pressing <F11> during the system bootup.

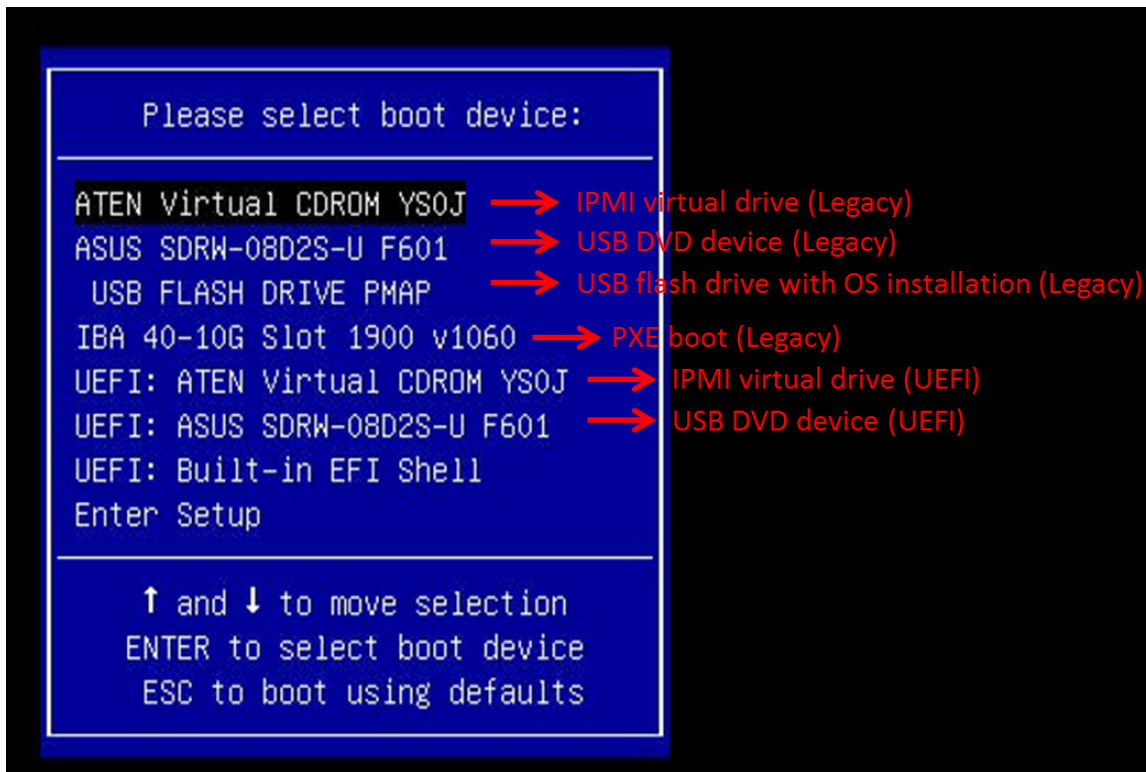

Figure A-1. Selecting the Boot Device

4. During Windows Setup, continue to the dialog box where you select the drives on which to install Windows. If the disk you want to use is not listed, click on the “Load driver” link at the bottom left corner.

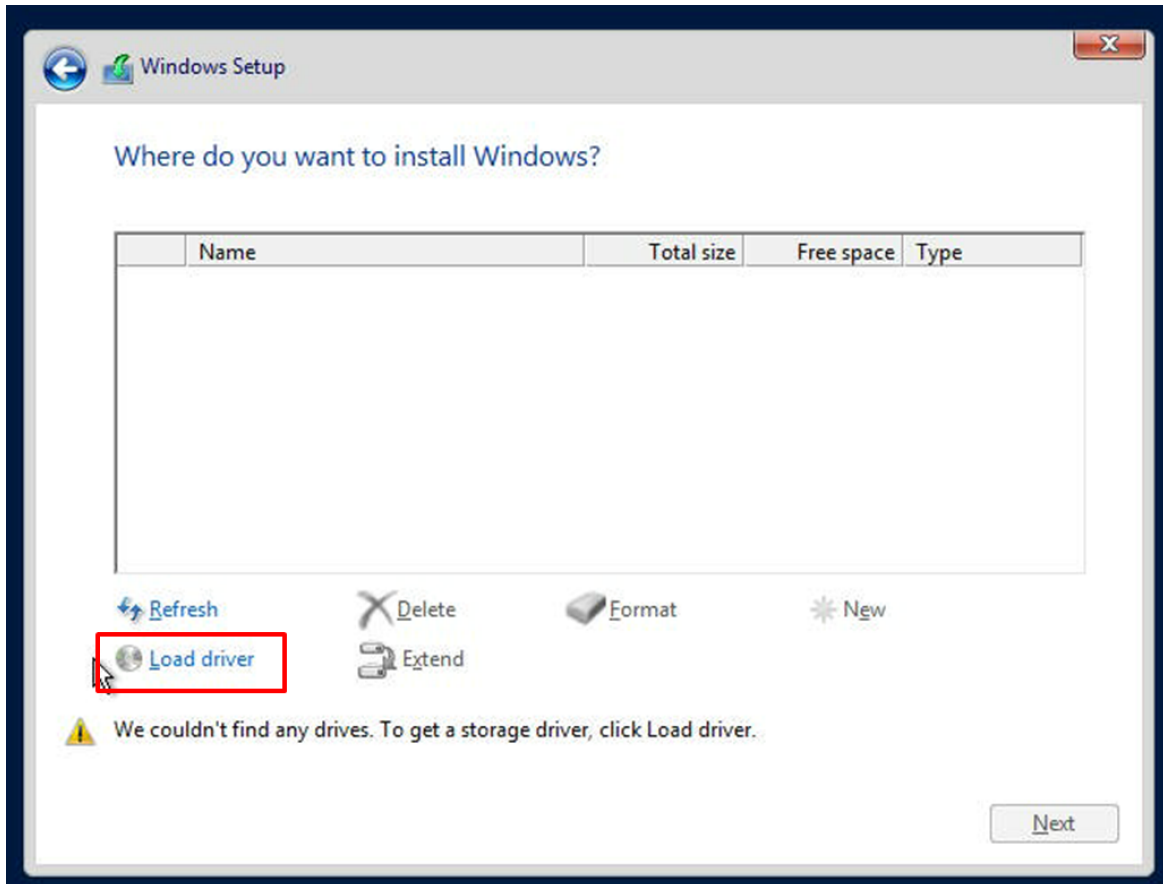

Figure A-2. Loading the Driver Link

To load the driver, browse the USB flash drive for the proper driver files.

5. Once all devices are specified, continue with the installation.
6. After the Windows OS installation has completed, the system will automatically reboot multiple times for system updates.

A.1 Driver Installation

The Supermicro website contains drivers and utilities for your system at the following page:

<https://www.supermicro.com/wdl>.

Some of these drivers and utilities must be installed, such as the chipset driver. After accessing the website, go into the CDR_Images (in the parent directory of the above link) and locate the ISO file for your motherboard. Download this file to a USB flash or media drive. You may also use a utility to extract the ISO file if preferred.

Another option is to go to the Supermicro website at <https://www.supermicro.com>. Find the product page for your motherboard and download the latest drivers and utilities. Insert the flash drive or disk, and the screenshot shown below should appear.

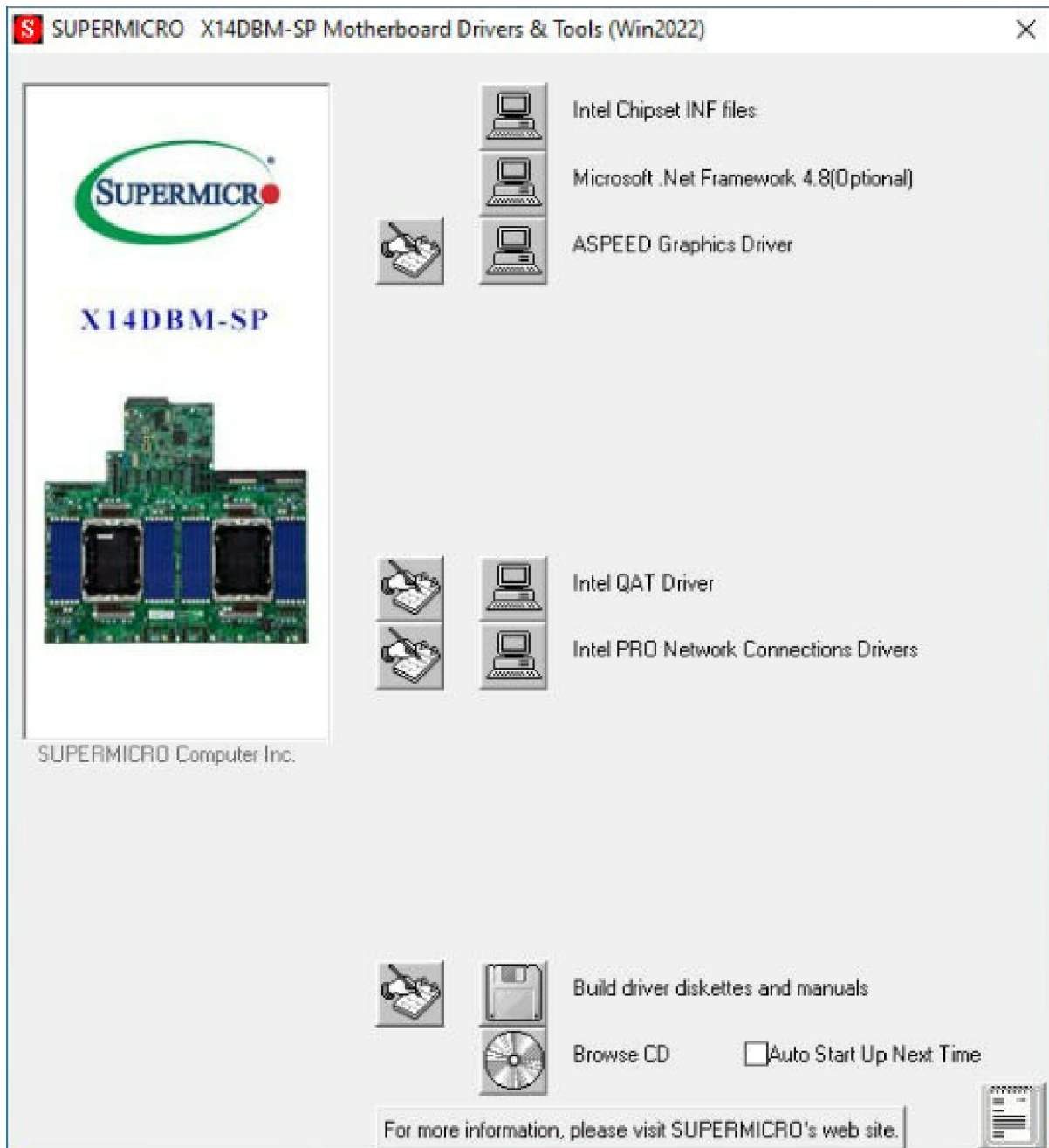

Figure A-3. Driver Installation

Note: Click the icons showing a hand writing on paper to view the readme files for each item. Click the computer icons to the right of these items to install each item (from top to bottom) one at a time. After installing each item, you must reboot the system before moving on to the next item on the list. The bottom icon with a CD on it allows you to view the entire contents.

BMC

The X14DBM-SP motherboard provides remote access, monitoring, and management through the baseboard management controller (BMC) and other management controllers distributed among different system modules. There are several BIOS settings that are related to BMC. For general documentation and information on BMC, visit our website at the following page:

<https://www.supermicro.com/en/solutions/management-software/bmc-resources>

BMC ADMIN User Password

For security, each system is assigned a unique default BMC password for the ADMIN user. The password can be found on a sticker on the motherboard and a sticker on the chassis, for Supermicro chassis. The sticker also displays the BMC MAC address. If necessary, the password can be reset using the Supermicro IPMICFG tool.



Figure A-4. BMC Password Label

Logging into the BMC

Supermicro ships standard products with a unique password for the BMC ADMIN user. This password can be found on a label on the motherboard.

When logging in to the BMC for the first time, use the unique password provided by Supermicro to log in. You can change the unique password to a user name and password of your choice for subsequent logins.

For more information regarding BMC passwords, visit our website at https://www.supermicro.com/en/support/BMC_Unique_Password.

Appendix B:

Standardized Warning Statements

The following statements are industry standard warnings, provided to warn the user of situations which have the potential for bodily injury. Should you have questions or experience difficulty, contact Supermicro's Technical Support department for assistance. Only certified technicians should attempt to install or configure components.

Read this section in its entirety before installing or configuring components in the Supermicro X14DBM-SP motherboard.

These warnings may also be found on our website at the following page:

https://www.supermicro.com/about/policies/safety_information.cfm

Battery Handling



CAUTION There is risk of explosion if the battery is replaced by an incorrect type. Replace the battery only with the same or equivalent type recommended by the manufacturer. Dispose of used batteries according to the manufacturer's instructions.

電池の取り扱い!

バッテリーを間違ったタイプに交換すると爆発の危険があります。交換する電池はメーカーが推奨する型、または同等のものを使用下さい。使用済電池は製造元の指示に従って処分して下さい。

警告!

如果更换的电池类型不正确。请只使用同类电池或制造商推荐的功能相当的电池更换原有电池。请按制造商的说明处理废旧电池。

警告!

如果更換的電池類型不正確。請使用製造商建議之相同或功能相當的電池更換原有電池。請按照製造商的說明指示處理廢棄舊電池。

WARNUNG!

Es besteht Explosionsgefahr, wenn die Batterie durch einen falschen Typ ersetzt wird. Ersetzen Sie die Batterie nur durch den gleichen oder vom Hersteller empfohlenen Batterietyp. Entsorgen Sie die benutzten Batterien nach den Anweisungen des Herstellers.

ADVERTENCIA!

Existe riesgo de explosión si la batería se reemplaza por un tipo incorrecto. Reemplazar la batería exclusivamente con el mismo tipo o el equivalente recomendado por el fabricante. Desechar las baterías gastadas según las instrucciones del fabricante.

ATTENTION!

Il existe un risque d'explosion si la batterie est remplacée par un type incorrect. Ne la remplacer que par une pile de type semblable ou équivalent, recommandée par le fabricant. Jeter les piles usagées conformément aux instructions du fabricant.

אזהרה!

קיימת סכנת פיצוץ אם הסוללה תוחלף בסוג שגוי. יש להחליף את הסוללה בסוג התואם מחברת יצרן מומלצת. סילוק הסוללות המשומשות יש לבצע לפי הוראות היצרן.

تحذير!

هناك خطر الانفجار إذا تم استبدال البطارية بنوع غير صحيح. اسحبذال البطارية فقط بنفس النوع أو ما يعادلها مما أوصت به الشركة المصنعة. جخلص من البطاريات المسحمة وفقاً لتعليمات الشركة الصانعة.

경고!

배터리를 잘못된 종류로 교체하면 폭발의 위험이 있습니다. 기존 배터리와 동일하거나 제조사에서 권장하는 동등한 종류의 배터리로만 교체해야 합니다. 제조사의 안내에 따라 사용된 배터리를 처리하여 주십시오.

WAARSCHUWING!

Er bestaat explosiegevaar als de batterij wordt vervangen door een verkeerd type. Vervang de batterij slechts met hetzelfde of een equivalent type die door de fabrikant aanbevolen wordt. Gebruikte batterijen dienen overeenkomstig fabrieksvoorschriften afgevoerd te worden.

Product Disposal

Warning! Ultimate disposal of this product should be handled according to all national laws and regulations.

製品の廃棄!

この製品を廃棄処分する場合、国の関係する全ての法律・条例に従い処理する必要があります。

警告!

本产品的废弃处理应根据所有国家的法律和规章进行。

警告!

本產品的廢棄處理應根據所有國家的法律和規章進行。

Warnung!

Die Entsorgung dieses Produkts sollte gemäß allen Bestimmungen und Gesetzen des Landes erfolgen.

¡Advertencia!

Al deshacerse por completo de este producto debe seguir todas las leyes y reglamentos nacionales.

Attention!

La mise au rebut ou le recyclage de ce produit sont généralement soumis à des lois et/ou directives de respect de l'environnement. Renseignez-vous auprès de l'organisme compétent.

אזהרה!

סילוק סופי של מוצר זה חייב להיות בהתאם להנחיות וחוקי המדינה.

تحذير!

عند التخلص النهائي من هذا المنتج ينبغي التعامل معه وفقا لجميع القوانين واللوائح الوطنية

경고!

이 제품은 해당 국가의 관련 법규 및 규정에 따라 폐기되어야 합니다.

Waarschuwing!

De uiteindelijke verwijdering van dit product dient te geschieden in overeenstemming met alle nationale wetten en reglementen.