



X14SAV-TLN4F/F

USER'S MANUAL

Revision 1.1a (MNL-2749)

The information in this User's Manual has been carefully reviewed and is believed to be accurate. The vendor assumes no responsibility for any inaccuracies that may be contained in this document, and makes no commitment to update or to keep current the information in this manual, or to notify any person or organization of the updates. Note: For the most up-to-date version of this manual, see our website at <https://www.supermicro.com>.

Super Micro Computer, Inc. ("Supermicro") reserves the right to make changes to the product described in this manual at any time and without notice. This product, including software and documentation, is the property of Supermicro and/or its licensors, and is supplied only under a license. Any use or reproduction of this product is not allowed, except as expressly permitted by the terms of said license.

IN NO EVENT WILL Super Micro Computer, Inc. BE LIABLE FOR DIRECT, INDIRECT, SPECIAL, INCIDENTAL, SPECULATIVE OR CONSEQUENTIAL DAMAGES ARISING FROM THE USE OR INABILITY TO USE THIS PRODUCT OR DOCUMENTATION, EVEN IF ADVISED OF THE POSSIBILITY OF SUCH DAMAGES. IN PARTICULAR, SUPER MICRO COMPUTER, INC. SHALL NOT HAVE LIABILITY FOR ANY HARDWARE, SOFTWARE, OR DATA STORED OR USED WITH THE PRODUCT, INCLUDING THE COSTS OF REPAIRING, REPLACING, INTEGRATING, INSTALLING OR RECOVERING SUCH HARDWARE, SOFTWARE, OR DATA.

Any disputes arising between manufacturer and customer shall be governed by the laws of Santa Clara County in the State of California, USA. The State of California, County of Santa Clara shall be the exclusive venue for the resolution of any such disputes. Supermicro's total liability for all claims will not exceed the price paid for the hardware product.

FCC Statement: This equipment has been tested and found to comply with the limits for a Class A or Class B digital device pursuant to Part 15 of the FCC Rules. These limits are designed to provide reasonable protection against harmful interference when the equipment is operated in industrial environment for Class A device or in residential environment for Class B device. This equipment generates, uses, and can radiate radio frequency energy and, if not installed and used in accordance with the manufacturer's instruction manual, may cause harmful interference with radio communications. Operation of this equipment in a residential area is likely to cause harmful interference, in which case you will be required to correct the interference at your own expense.

California Best Management Practices Regulations for Perchlorate Materials: This Perchlorate warning applies only to products containing CR (Manganese Dioxide) Lithium coin cells. "Perchlorate Material-special handling may apply. See <https://www.dtsc.ca.gov/hazardouswaste/perchlorate>".



WARNING: This product can expose you to chemicals including lead, known to the State of California to cause cancer and birth defects or other reproductive harm. For more information, go to <https://www.P65Warnings.ca.gov>.



AVERTISSEMENT : Ce produit peut vous exposer à des agents chimiques, y compris le plomb, identifié par l'État de Californie comme pouvant causer le cancer, des malformations congénitales ou d'autres troubles de la reproduction. Pour de plus amples informations, prière de consulter <https://www.P65Warnings.ca.gov>.

The products sold by Supermicro are not intended for and will not be used in life support systems, medical equipment, nuclear facilities or systems, aircraft, aircraft devices, aircraft/emergency communication devices or other critical systems whose failure to perform be reasonably expected to result in significant injury or loss of life or catastrophic property damage. Accordingly, Supermicro disclaims any and all liability, and should buyer use or sell such products for use in such ultra-hazardous applications, it does so entirely at its own risk. Furthermore, buyer agrees to fully indemnify, defend and hold Supermicro harmless for and against any and all claims, demands, actions, litigation, and proceedings of any kind arising out of or related to such ultra-hazardous use or sale.

Manual Revision 1.1a

Release Date: June 12, 2026

Unless you request and receive written permission from Super Micro Computer, Inc., you may not copy any part of this document. Information in this document is subject to change without notice. Other products and companies referred to herein are trademarks or registered trademarks of their respective companies or mark holders.

Copyright © 2026 by Super Micro Computer, Inc.
All rights reserved.

Published in the United States of America

Preface

About This Manual

This manual is written for professional system integrators and PC technicians. It provides information for the installation and use of the X14SAV-TLN4F/F motherboard. Installation and maintenance should be performed by certified service technicians only.

Notes

For your system to work properly, follow the links below to download all necessary drivers/utilities and the user's manual for your motherboard.

- Supermicro product manuals: <https://www.supermicro.com/support/manuals>
- Product drivers and utilities: <https://www.supermicro.com/wdl>
- Product safety info: https://www.supermicro.com/about/policies/safety_information.cfm
- A secure data deletion tool designed to fully erase all data from storage devices can be found on our website:
https://www.supermicro.com/about/policies/disclaimer.cfm?url=/wdl/utility/Lot9_Secure_Data_Deletion_Utility
- Frequently Asked Questions: <https://www.supermicro.com/FAQ/index.php>
- If you still have questions after referring to our FAQs, contact our support team. Region-specific Technical Support email addresses can be found at: "[Contacting Supermicro](#)" on page 11
- If you have any feedback on Supermicro product manuals, contact our writing team at: Techwriterteam@supermicro.com

This manual may be periodically updated without notice. Check the Supermicro website for possible updates to the manual revision level.

Conventions Used in the Manual

Special attention should be given to the following symbols for proper installation and to prevent damage done to the components or injury to yourself.



Warning! Indicates important information given to prevent equipment/property damage or personal injury.



Warning! Indicates high voltage may be encountered while performing a procedure.



Warning! Indicates hazardous moving parts may be encountered while handling a fan or components near a fan.

Important: Important information given to ensure proper motherboard installation or to relay safety precautions.

Note: Additional information given to differentiate various models or to provide information for proper motherboard setup.

Contents

Contacting Supermicro	11
Chapter 1: Introduction	12
1.1 Quick Reference	13
Checklist	13
Motherboard Layout	14
Quick Reference	17
Motherboard Features	19
Motherboard Block Diagram	22
1.2 Platform Overview	23
1.3 Special Features	24
Recovery from AC Power Loss	24
1.4 System Health Monitoring	25
Onboard Voltage Monitors	25
Fan Status Monitor with Firmware Control	25
Environmental Temperature Control	25
1.5 ACPI Features	26
Slow Blinking LED for Suspend-State Indicator	26
1.6 Serial Header	27
Chapter 2: Component Installation	28
2.1 Static-Sensitive Devices	30
Precautions	30
Unpacking	30
2.2 Motherboard Installation	31
Tools Needed	31
Installing the Motherboard	31
2.3 Processor and Heatsink Installation	33
Installing an LGA 1851 Processor	33
Installing a Processor Heatsink	37
Removing the Processor Heatsink	41
2.4 Memory Support and Installation	42
Memory Support	42

General Guidelines for Optimizing Memory Performance	42
SODIMM Installation	42
SODIMM Removal	44
2.5 Battery Removal and Installation	45
Battery Removal	45
Proper Battery Disposal	45
Battery Installation	45
Input/Output Ports	46
HDMI and DP Ports	47
LAN Ports	47
Unit Identifier Button	47
USB Ports	48
Front Control Panel	49
Power Button	49
Reset Button	49
Overheat/Fan Fail LED	50
NIC1/NIC2 (LAN1/LAN2)	50
HDD LED	51
Power LED	51
NMI Button	51
2.6 Connections, Jumpers, and LEDs	53
Power Supply and Power Connections	53
Power Supply	53
4-Pin HDD Power Connector	53
4-pin DC Power Source	54
8-pin DC Power Connector	54
Headers and Connections	54
Chassis Intrusion	54
CMOS Battery	55
COM Header	55
External BMC I ² C Header	55
Fan Headers	56
M.2 Slots	56
MCIO PCIe 4.0 x8 Connector	59

MCIO PCIe 4.0 x4 Connector	60
Power SMB (I ² C) Header	60
Power SMB Header	60
Speaker Header	61
TPM/Port 80 Header	61
VGA Header	62
USB Headers	62
Jumper Settings	63
CMOS Clear	63
LAN1 Enable/Disable	64
LAN2 Enable/Disable	64
ME Manufacturing Mode	65
PCIe Bifurcation	65
Onboard TPM Enable/Disable	65
SIM Detect Option	66
VGA Enable/Disable	66
Watchdog Timer	67
LED Indicators	67
BMC Heartbeat LED	67
Power LED	68
Unit ID (UID) LED	68
Chapter 3: Troubleshooting	69
3.1 Troubleshooting Procedures	70
Before Power On	70
No Power	70
No Video	70
System Boot Failure	70
Memory Errors	71
Losing the System's Setup Configuration	71
If the System Becomes Unstable	71
3.2 Technical Support Procedures	73
3.3 Motherboard Battery	74
3.4 Where to Get Replacement Components	75
3.5 Returning Merchandise for Service	76

3.6 Feedback	77
Chapter 4: UEFI BIOS	78
4.1 Introduction	79
Updating BIOS	79
Starting the Setup Utility	79
4.2 Main Setup	81
4.3 Advanced Setup Configurations	83
ACPI Settings Menu	83
Boot Feature Menu	84
CPU Configuration Menu	86
Chipset Configuration Menu	89
Memory Configuration Menu	90
Graphics Configuration Menu	91
DMI Configuration Menu	92
PEG Port Configuration	92
GT - Power Management Control	92
PCH-IO Configuration	93
PCI Express Configuration	93
Onboard LAN1	93
Onboard LAN2	93
MCIO-1	94
MCIO-2	94
M.2-H	95
HTTP Boot Configuration Menu	95
Super IO Configuration Menu	96
Serial Port 1 Configuration Menu	97
Serial Port 2 Configuration Menu	97
Network Stack Configuration Menu	97
MAC:(MAC address)-IPv4 Network Configuration Menu	98
MAC:(MAC address)-IPv6 Network Configuration Menu	99
MAC:(MAC address)-IPv4 Network Configuration Menu	100
MAC:(MAC address)-IPv6 Network Configuration Menu	101
MAC:(MAC address)-IPv4 Network Configuration Menu	102
MAC:(MAC address)-IPv6 Network Configuration Menu	103

MAC:(MAC address)-IPv4 Network Configuration Menu	104
MAC:(MAC address)-IPv6 Network Configuration Menu	105
PCH-FW Configuration	106
AMT Configuration	106
ASF Configuration	106
Secure Erase Configuration	107
One Click Recovery (OCR) Configuration	107
PCIe/PCI/PnP Configuration Menu	108
SATA and RST Configuration	109
VMD Setup Menu	110
Serial Port Console Redirection Menu	110
Trusted Computing Menu	114
USB Configuration Menu	116
Intel Ethernet Controller I226-LM	116
Intel Ethernet Controller I226-LM	116
Intel Ethernet Controller X550	116
Firmware Image Properties	117
NIC Configuration	117
Intel Ethernet Controller X550	117
Firmware Image Properties	118
NIC Configuration	118
TLS Authenticate Configuration Menu	118
Driver Health Menu	119
4.4 Event Logs	120
4.5 BMC	122
System Event Log Menu	122
BMC Network Configuration Menu	123
4.6 Security	126
Secure Boot Menu	127
4.7 Boot	130
4.8 Save & Exit	132
4.9 MEBx	134
Appendix A: BIOS Codes	143
BIOS Error POST (Beep) Codes	143

Additional BIOS POST Codes	143
Appendix B: Software	144
Microsoft Windows OS Installation	144
Installing the OS	144
Driver Installation	146
BMC	148
BMC ADMIN User Password	148
Appendix C: Standardized Warning Statements	149
Battery Handling	149
Product Disposal	151

Contacting Supermicro

Headquarters

Address: Super Micro Computer, Inc.
980 Rock Ave.
San Jose, CA 95131 U.S.A.

Tel: +1 (408) 503-8000

Fax: +1 (408) 503-8008

Email: Marketing@supermicro.com (General Information)
Sales-USA@supermicro.com (Sales Inquiries)
Government_Sales-USA@supermicro.com (Gov. Sales Inquiries)
Support@supermicro.com (Technical Support)
RMA@Supermicro.com (RMA Support)
Webmaster@supermicro.com (Webmaster)

Website: <https://www.supermicro.com>

Europe

Address: Super Micro Computer B.V.
Het Sterrenbeeld 28, 5215 ML
's-Hertogenbosch, The Netherlands

Tel: +31 (0) 73-6400390

Fax: +31 (0) 73-6416525

Email: Sales_Europe@supermicro.com (Sales Inquiries)
Support_Europe@supermicro.com (Technical Support)
RMA_Europe@supermicro.com (RMA Support)

Website: <https://www.supermicro.nl>

Asia-Pacific

Address: Super Micro Computer, Inc.
3F, No. 150, Jian 1st Rd.
Zhonghe Dist., New Taipei City 235 Taiwan (R.O.C)

Tel: +886 (2) 8226-3990

Fax: +886 (2) 8226-3992

Email: Sales-Asia@supermicro.com.tw (Sales Inquiries)
Support@supermicro.com.tw (Technical Support)
RMA@supermicro.com.tw (RMA Support)

Website: <https://www.supermicro.com.tw>

Chapter 1:

Introduction

Congratulations on purchasing your computer motherboard from an industry leader. Supermicro motherboards are designed to provide you with the highest standards in quality and performance.

1.1 Quick Reference	13
Checklist	13
Motherboard Layout	14
Quick Reference	17
Motherboard Features	19
Motherboard Block Diagram	22
1.2 Platform Overview	23
1.3 Special Features	24
Recovery from AC Power Loss	24
1.4 System Health Monitoring	25
Onboard Voltage Monitors	25
Fan Status Monitor with Firmware Control	25
Environmental Temperature Control	25
1.5 ACPI Features	26
Slow Blinking LED for Suspend-State Indicator	26
1.6 Serial Header	27

1.1 Quick Reference

For details on the X14SAV-TLN4F/F motherboard layout, features, and other quick reference information, refer to the content below.

Checklist

In addition to the X14SAV-TLN4F/F motherboard, several important parts that are included in your shipment are listed below. If anything listed is damaged or missing, contact your retailer.

Main Parts List		
Description	Part Number	Quantity
Supermicro Motherboard	X14SAV-TLN4F/F	1
Quick Reference Guide	MNL-2749-QRG	1

Motherboard Layout

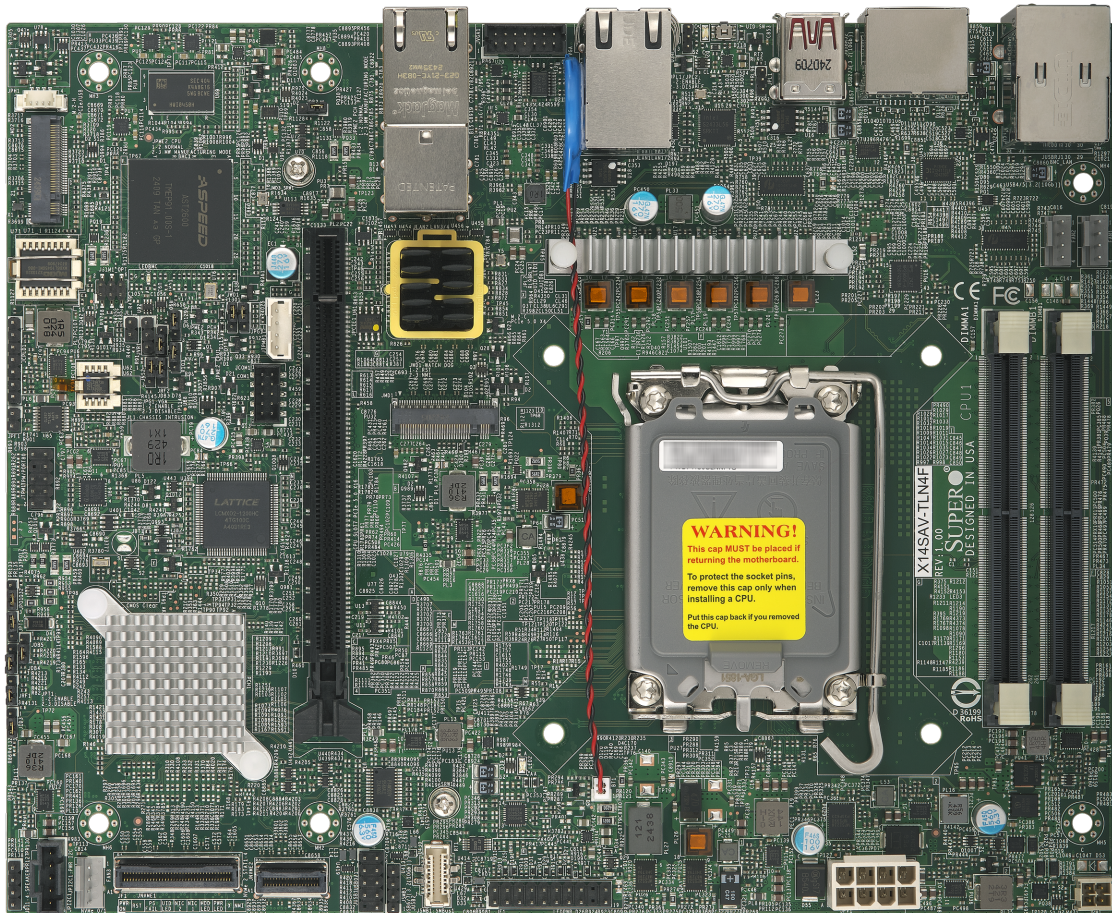

Figure 1-1. X14SAV-TLN4F Motherboard Photo

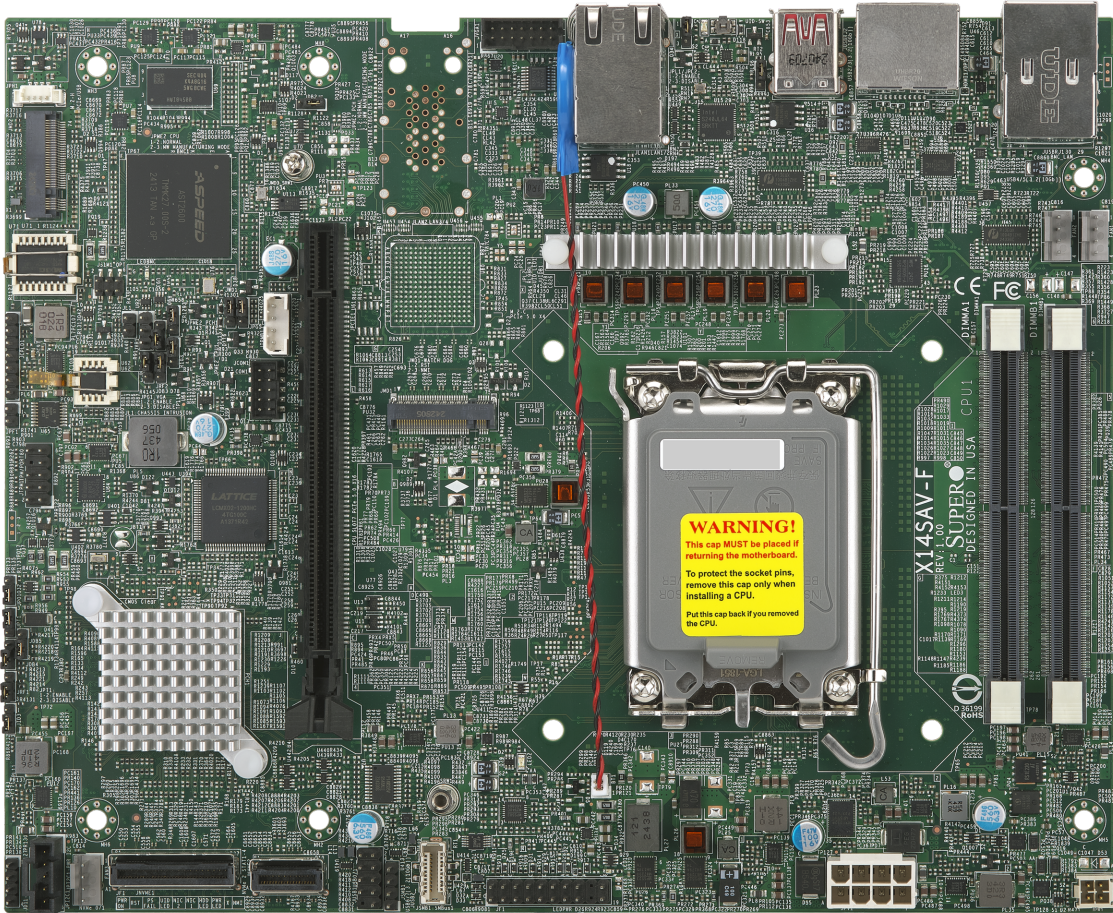

Figure 1-2. X14SAV-F Motherboard Photo

Quick Reference

For details on the X14SAV-TLN4F/F motherboard layout, features, and other quick reference information, refer to the content below.

Jumper	Description	Default Settings
JBT1	CMOS Clear	Open (Normal)
JNS2	M.2 B-Key Mode Selection	Pins 1–2 (USB 3.0) Pins 2–3 (PCIe 4.0)
JPG1	VGA Enable/Disable	Pins 1–2 (Enabled)
JPL1	LAN1 Enable/Disable	Pins 1–2 (Enabled)
JPL2	LAN2 Enable/Disable	Pins 1–2 (Enabled)
JPME2_CPU1	ME Manufacturing Mode	Pins 1–2 (Normal)
JPME2_PCH1	ME Manufacturing Mode	Pins 1–2 (Normal)
JPO1	CPU Throttle when PWR_FAIL	Pins 1–2 (Enabled) Pins 2–3 (Disabled) (Default)
JPT1	Onboard TPM 2.0 Enable/Disable	Pins 1–2 (Enabled)
JRF1, JRF2	PCIe Bifurcation	JRF1 JRF2 PEG Pins 2–3 Pins 2–3 x16 (PCIe) (Default) Pins 1–2 Pins 2–3 2x8 (PCIe) Pins 2–3 Pins 1–2 1x8, 2x4 (PCIe)
JSIM_OPT1	USB or PCI Interface Optional SIM Detect M.2 B-Key Storage LED	Pins 1–3 Short (USB) Pins 2–4 Short (Low Active) Pins 5–6 Enabled
JWD1	Watchdog Timer	Pins 1–2 (Reset)

Connector	Description
BT1	Onboard Battery
FAN1–FAN3	Fan Headers
HDMI1/DP1	High Definition Multimedia Interface/DisplayPort
JCOM1	COM Header (supports RS232)
JD1	Speaker/Buzzer (Pins: 1–4: Speaker, Pins 3–4: Buzzer)
JF1	Front Control Panel Header
JIPMB1	4-pin BMC External I ² C Header
JL1	Chassis Intrusion Header
JLAN1	2.5G LAN1/2 Ports
JLAN2	10G LAN3/4 Ports
JMD1	M.2 M-Key Slot (PCIe 5.0 x4)
JMD2	M.2 B-Key Slot (PCIe 4.0/USB 3.0)
JMD1_SRW1	M.2 Mounting Hole for JMD1
JMD2_SRW1	M.2 Mounting Hole for JMD2
JNVME1	MCIO Slot supports two PCIe 4.0x Connectors
JNVME2	MCIO Slot supports four SATA (or PCIe x4 by OEM BIOS)
JPCIE1	PCIe 5.0 x16 Slot
JPH1	4-pin HDD Power Connector
JPI2C1	Power System Management Bus (SMB) I ² C Header
JPV1	8-pin +12 V DC Power Connector for CPU (Required) or alternative single power input for when the 24-pin ATX is not in use
JPW1	4-pin +12 V Power Source
JSMB1	Power Mangement Bus Header
JTPM1	Trusted Platform Module/Port 80 Connector
JUSB1	USB 2.0 Header (USB0/1)
JUSB2	USB 3.2 (10 Gb) Header (USB6/7)

Connector	Description
JUSBRJ1	BMC LAN/USB4/5 Ports (USB 3.2, 10 Gb)
JUSBRJ2	USB 3.2 (10 Gb) Ports (USB2/3)
JVGA1	VGA Header
MH2–MH6, MH8	Mounting Holes
UID_SW	Unit Identifier Button

LED	Description	Status
LED1	Power LED	Solid Green: Power On
LED2	OH/Fan Fail LED	Blinking Red: OH/Fan fail
LED3	BMC LED	Blinking Orange: BMC Normal
UID_LED1	Unit Identifier (UID) LED	Solid Blue: Unit Identified

Motherboard Features

Motherboard Features
CPU
<ul style="list-style-type: none"> Intel® Core Ultra 9/7/5 Series 2 processor with a Thermal Design Power (TDP) of up to 125 W in the LGA 1851 socket
Memory
<ul style="list-style-type: none"> Supports up to 96 GB of ECC or Non-ECC DDR5 SODIMM memory with speeds of up to 5600 MT/s in two slots Supports up to 6400 MT/s with U9/U7 processor
DIMM Size
<ul style="list-style-type: none"> 16 GB, 24 GB, 32 GB, 48 GB
Expansion Slots
<ul style="list-style-type: none"> One PCIe 5.0 x16 slot One M.2 M-Key 2280 PCIe 5.0 slot One M.2 B-Key 3052 PCIe 4.0/USB3.0 Slot One MCIO x8 connector One MCIO x4 connector (supports four SATA by default)

Motherboard Features
Network
<ul style="list-style-type: none"> • Intel X550-AT2 for dual 10G LAN ports (Not available on X14SAV-F) • Intel I226 for dual 2.5G LAN ports
Graphics
<ul style="list-style-type: none"> • Intel Xe LPG Graphics
I/O Devices
<ul style="list-style-type: none"> • One HDMI 2.1 port • One DisplayPort 2.1 • One COM header
Peripheral Devices
<ul style="list-style-type: none"> • Four USB 2.0 ports • Six USB 3.2 Gen 2 ports
BIOS
<ul style="list-style-type: none"> • 256 Mb MX2515245GMI-08G BIOS • ACPI 6.0, Plug and Plug (PnP), SPI dual/quad support, Riser card auto detection support, Real Time Clock (RTC) wake-up
Power Management
<ul style="list-style-type: none"> • ACPI Power Management (S3, S4, S5) • Power Button Override Mechanism • Wake-On-LAN • Power-on Mode for AC Power Recovery
System Health Monitoring
<ul style="list-style-type: none"> • +3.3 V, +5 V, +12 V, 5V_AUX, 3.3V_AUX, 1.8V_AUX, CPU_VCCON, CPU_VCCIN, BMC +2.5 V, BMC +1.2 V, BMC +1.0 V, Vcore, Vmem, CPU, PCH, System, DIMM, and Peripheral temperature • Temperature: M.2 K-Key, X550 (LAN3/4) • CPU Thermal Trip support • Platform Environment Control Interface (PECI)/TSI
Fan Control
<ul style="list-style-type: none"> • Three 4-pin Fan headers • Low noise fan speed control

Motherboard Features
System Management
<ul style="list-style-type: none">• Trusted Platform Module (TPM) 2.0• SAA
LED Indicators
<ul style="list-style-type: none">• Power/suspend-state indicator LED• HDD Activity LED• LAN Activity LED
Dimensions
<ul style="list-style-type: none">• 9" x 7.25" (228.6 mm x 184.15 mm) (W x L)

Motherboard Block Diagram

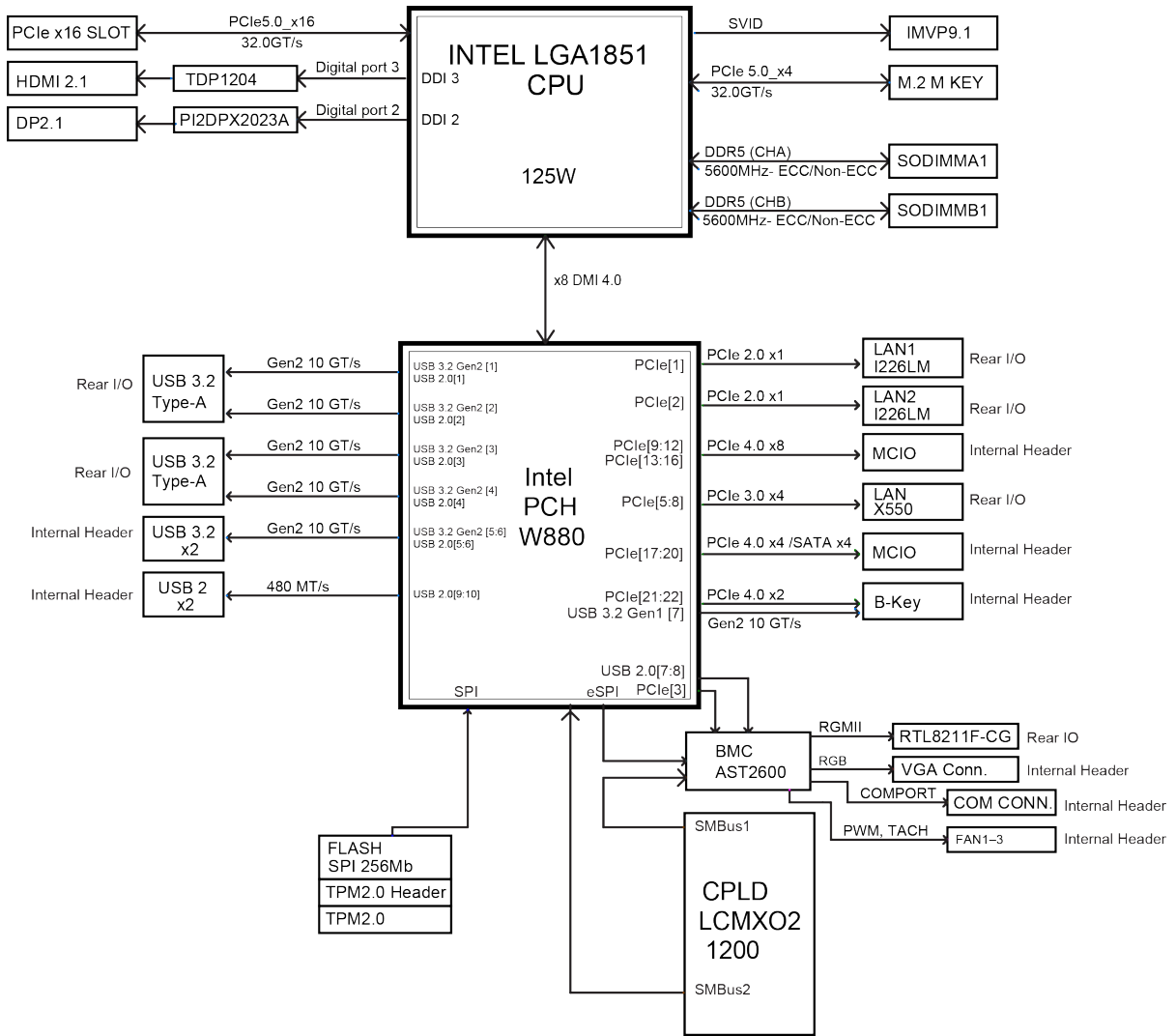

Figure 1-4. X14SAV-TLN4F Motherboard Block Diagram

1.2 Platform Overview

Built upon the functionality and capability of the 15th Generation Intel Core Ultra 5/7/9 Processor (in LGA1851) and the Intel 800 Series chipset, the X14SAV-TLN4F/F motherboard provides system performance, power efficiency, and feature sets to address the needs of next-generation computer users.

With the support of the new Intel Microarchitecture 20A Enhanced SuperFin Process Technology, the X14SAV-TLN4F/F motherboard dramatically increases system performance for a multitude of system applications and supports the following features:

- DDR5 288-pin memory support
- Direct Media Interface
- Intel Matrix Storage Technology and Intel Rapid Storage Technology
- Intel I/O Virtualization (VT-d) Support
- Intel Trusted Execution Technology Support
- PCIe 5.0 Interface (up to 32 GT/s)
- SATA Controller (up to 6 Gb/sec)
- Advanced Host Controller Interface (AHCI)

1.3 Special Features

Recovery from AC Power Loss

The Basic I/O System (BIOS) provides a setting that determines how the system will respond when AC power is lost and then restored to the system. You can choose for the system to remain powered off (in which case you must press the power switch to turn it back on), or for it to automatically return to the power-on state. See Advanced Setup Configurations under "[UEFI BIOS](#)" on [page 78](#) for this setting. The default setting is **Last State**.

1.4 System Health Monitoring

Onboard Voltage Monitors

An onboard voltage monitor will continuously scan the voltages of the onboard chipset, memory, processor, and battery. Once a voltage becomes unstable, a warning is given or an error message is sent to the screen. You can adjust the voltage thresholds to define the sensitivity of the voltage monitor. Real time voltage levels are displayed in IPMI.

Fan Status Monitor with Firmware Control

The system health monitor embedded in the BMC chip can check the RPM status of the cooling fans. The processor and chassis fans are controlled via IPMI.

Environmental Temperature Control

System Health sensors in the BMC monitor the temperatures and voltage settings of onboard processors and the system in real time via the IPMI interface. Whenever the temperature of the processor or the system exceeds a user-defined threshold, system/processor cooling fans will be turned on to prevent the processor or the system from overheating.

Note: To avoid possible system overheating, be sure to provide adequate airflow to your system.

1.5 ACPI Features

ACPI stands for Advanced Configuration and Power Interface. The ACPI specification defines a flexible and abstract hardware interface that provides a standard way to integrate power management features throughout a computer system, including its hardware, operating system and application software. This enables the system to automatically turn on and off peripherals such as network cards, hard disk drives, and printers.

In addition to enabling operating system-directed power management, ACPI also provides a generic system event mechanism for Plug and Play, and an operating system-independent interface for configuration control. ACPI leverages the Plug and Play BIOS data structures, while providing a processor architecture-independent implementation that is compatible with appropriate Windows operating systems. For detailed information regarding OS support, refer to the Supermicro website.

Slow Blinking LED for Suspend-State Indicator

When the CPU goes into a suspend state, the chassis power LED will start to blink to indicate that the CPU is in suspend mode. When the user presses any key, the CPU will "wake up," and the LED will automatically stop blinking and remain on.

1.6 Serial Header

The X14SAV-TLN4F/F motherboard supports one serial communication connection. The COM header can be used for input/output. The UART provides legacy speeds with a baud rate of up to 115.2 Kbps as well as an advanced speed with baud rates of 250 Kbps, 500 Kbps, or 1 Mbps, which support high-speed serial communication devices.

Chapter 2:

Component Installation

This chapter provides instructions on installing and replacing main system components for the X14SAV-TLN4F/F motherboard. To prevent compatibility issues, only use components that match the specifications and/or part numbers given.

Installation or replacement of most components require that power first be removed from the system. Follow the procedures given in each section.

2.1 Static-Sensitive Devices	30
Precautions	30
Unpacking	30
2.2 Motherboard Installation	31
Tools Needed	31
Installing the Motherboard	31
2.3 Processor and Heatsink Installation	33
Installing an LGA 1851 Processor	33
Installing a Processor Heatsink	37
Removing the Processor Heatsink	41
2.4 Memory Support and Installation	42
Memory Support	42
General Guidelines for Optimizing Memory Performance	42
SODIMM Installation	42
SODIMM Removal	44
2.5 Battery Removal and Installation	45
Battery Removal	45
Proper Battery Disposal	45
Battery Installation	45
Input/Output Ports	46
HDMI and DP Ports	47
LAN Ports	47
Unit Identifier Button	47
USB Ports	48

Front Control Panel	49
Power Button	49
Reset Button	49
Overheat/Fan Fail LED	50
NIC1/NIC2 (LAN1/LAN2)	50
HDD LED	51
Power LED	51
NMI Button	51
2.6 Connections, Jumpers, and LEDs	53
Power Supply and Power Connections	53
Headers and Connections	54
Jumper Settings	63
LED Indicators	67

2.1 Static-Sensitive Devices

Electrostatic Discharge (ESD) can damage electronic components. To avoid damaging your motherboard, it is important to handle it very carefully. The following measures are generally sufficient to protect your equipment from ESD.

Precautions

- Use a grounded wrist strap designed to prevent static discharge.
- Touch a grounded metal object before removing the board from the antistatic bag.
- Handle the motherboard only by its edges. Do not touch its components, peripheral chips, memory modules, or gold contacts.
- When handling chips or modules, avoid touching their pins.
- Put the motherboard and peripherals back into their antistatic bags when not in use.
- For grounding purposes, make sure that your computer chassis provides excellent conductivity between the power supply, the case, the mounting fasteners, and the motherboard.
- Use only the correct type of onboard CMOS battery. To avoid possible explosion, do not install the onboard battery upside down.

Unpacking

To avoid static damage, the motherboard is shipped in antistatic packaging. When unpacking the motherboard, make sure that the person handling it is static protected.

2.2 Motherboard Installation

All motherboards have standard mounting holes to fit different types of chassis. Make sure that the locations of all the mounting holes for both the motherboard and the chassis match. Although a chassis may have both plastic and metal mounting fasteners, metal ones are highly recommended because they ground the motherboard to the chassis. Make sure that the metal standoffs click in or are screwed in tightly.

Tools Needed

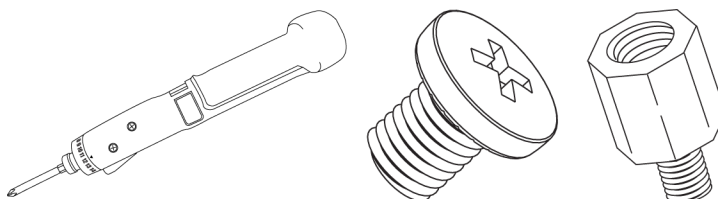

Figure 2-1. Torque Driver (1), Phillips Screws (4), Standoffs (4, only if needed)

Notes:

- To avoid damaging the motherboard and its components, do not use a force greater than 8 lbf-in on each mounting screw during motherboard installation.
- Some components are very close to the mounting holes. Take precautionary measures to avoid damaging these components when installing the motherboard to the chassis.

Installing the Motherboard

1. Install the I/O shield into the back of the chassis, if applicable.

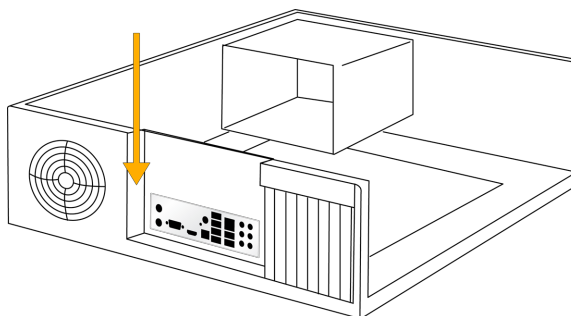

Figure 2-2. Installing the I/O Shield

Note: Images displayed are for illustration purposes only. The components installed in your system may or may not look exactly the same as the graphics shown in the manual.

2. Locate the mounting holes on the motherboard. See Motherboard Installation for the location.

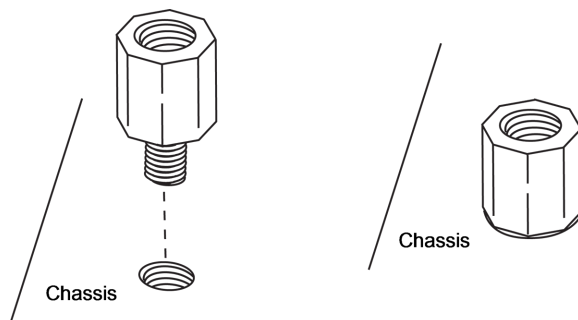

Figure 2-3. Locating the Mounting Holes

3. Locate the matching mounting holes on the chassis. Align the mounting holes on the motherboard against the mounting holes on the chassis.

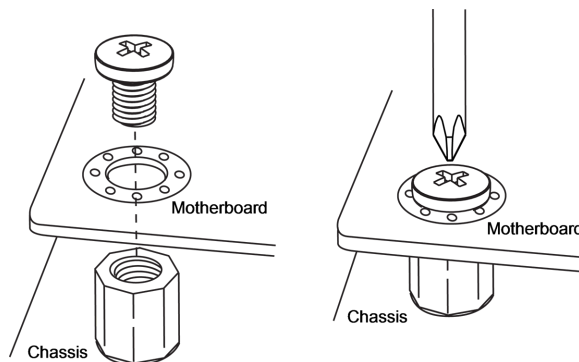

Figure 2-4. Aligning the Mounting Holes

4. Install standoffs in the chassis as needed.
5. Install the motherboard into the chassis carefully to avoid damaging other motherboard components.
6. Insert pan head #6 screws into the mounting holes on the motherboard and the matching mounting holes on the chassis.
7. Make sure that the motherboard is securely placed in the chassis.

2.3 Processor and Heatsink Installation

This section provides procedures to install the processor(s) and heatsink(s).

Notes:

- Take industry standard precautions to avoid ESD damage. For details, see "[Static-Sensitive Devices](#)" on page 30.
- Before starting, make sure that the plastic socket cap is in place and none of the socket pins are bent. If any damage is noted, contact your retailer.
- Do not connect the system power cord before the processor and heatsink installation is complete.
- When handling the processor, avoid touching or placing direct pressure on the LGA lands (gold contacts). Improper installation or socket misalignment can cause serious damage to the processor or processor socket.
- Install the processor in the socket and the motherboard into the chassis before installing the heatsink.
- When buying a processor separately, use only a Supermicro certified heatsink.
- Refer to the Supermicro website for the most recent processor support.
- When installing the heatsink, ensure a torque driver set to the correct force is used for each screw.
- Thermal grease is pre-applied on a new heatsink. No additional thermal grease is needed.

Installing an LGA 1851 Processor

Important: You can only install the processor in one direction. Make sure it is properly inserted into the socket before closing the load plate. If it doesn't close properly, do not force it as it may damage your processor. Instead, open the load plate again and double-check that the processor is properly aligned.

1. Remove the plastic protective cover from the load plate.

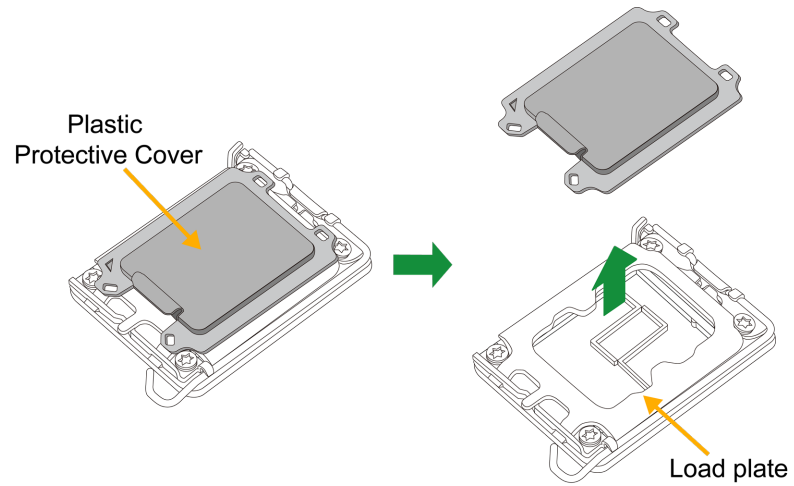

Figure 2-5. Removing the Protective Cover

2. Gently push the load lever down and away from the lever lock, then lift it up completely.

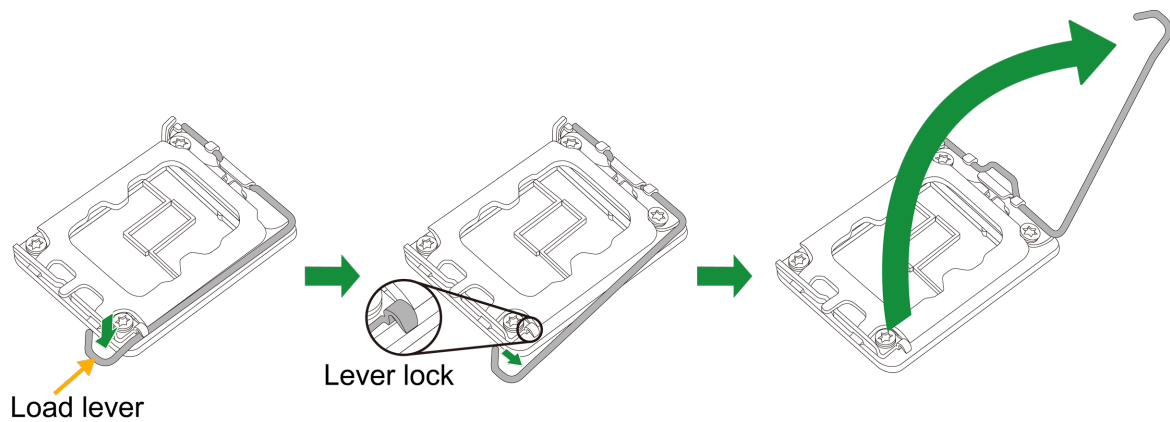

Figure 2-6. Releasing and Lifting the Lever

3. Lift the load plate to open it completely.

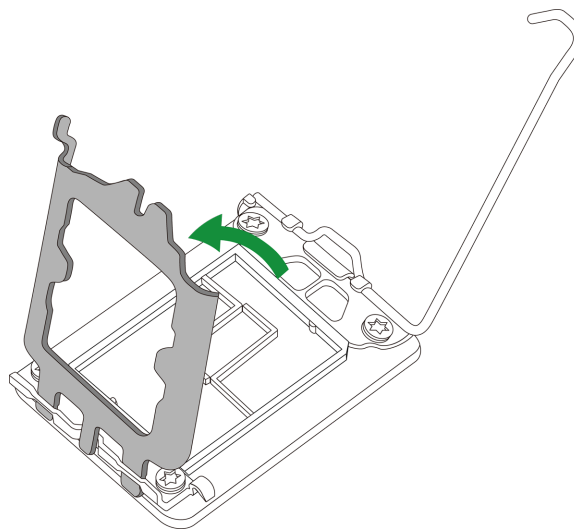

Figure 2-7. Opening the Load Plate

4. Carefully hold the processor by its edges. Align the small triangle marker and notches on the processor with the corresponding triangle marker and notches on the processor load bracket. Once aligned, carefully lower the processor straight down into the socket. (Do not drop the processor on the socket, or move it horizontally or vertically.)

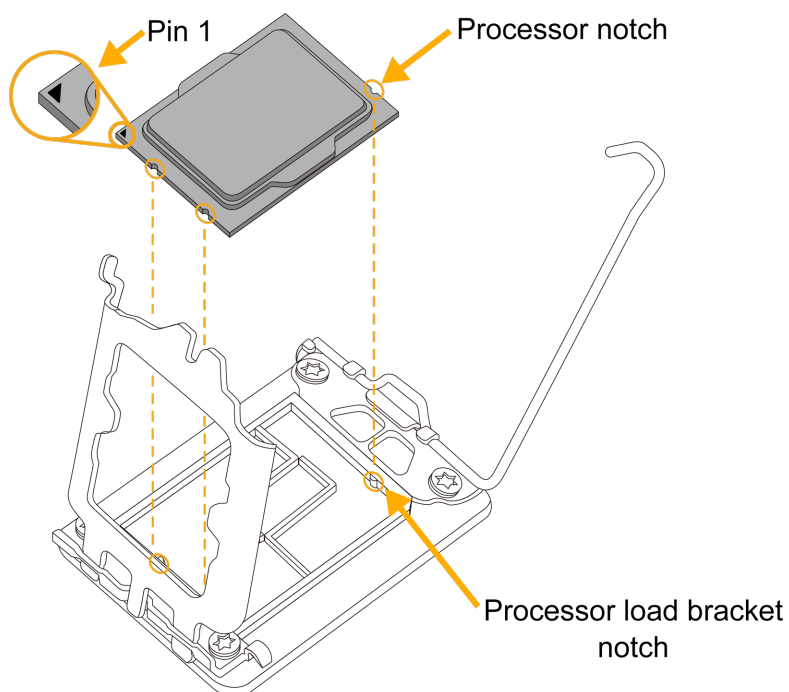

Figure 2-8. Aligning the Notches and Installing the Processor

5. Do not rub the processor against the surface or against any pins of the socket to avoid damaging the processor or the socket.

6. With the processor inside the socket, inspect all the corners to make sure it is properly installed.
7. Close the load plate with the processor inside the socket. Gently push the load lever down until it locks under the lever lock.

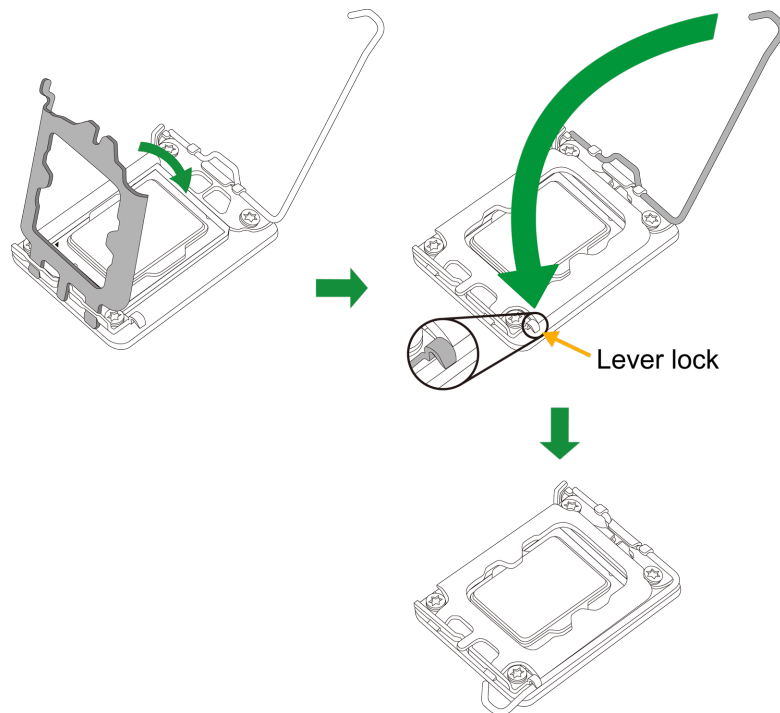

Figure 2-9. Closing the Load Plate and Pushing the Lever Down

Installing a Processor Heatsink

1. Loosen four screws to release the backplate. Note that one screw is not shown in the illustration below.

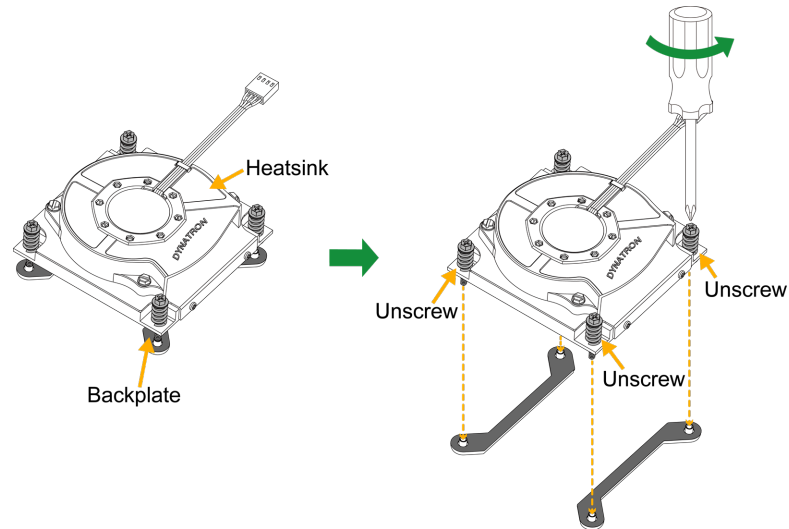

Figure 2-10. Releasing the Backplate from the Heatsink

2. If there is a thin layer of protective film on the backplate, remove it.

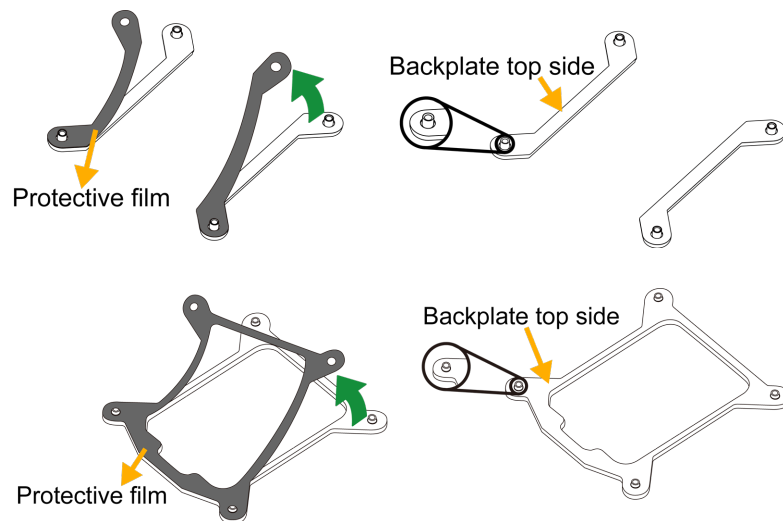
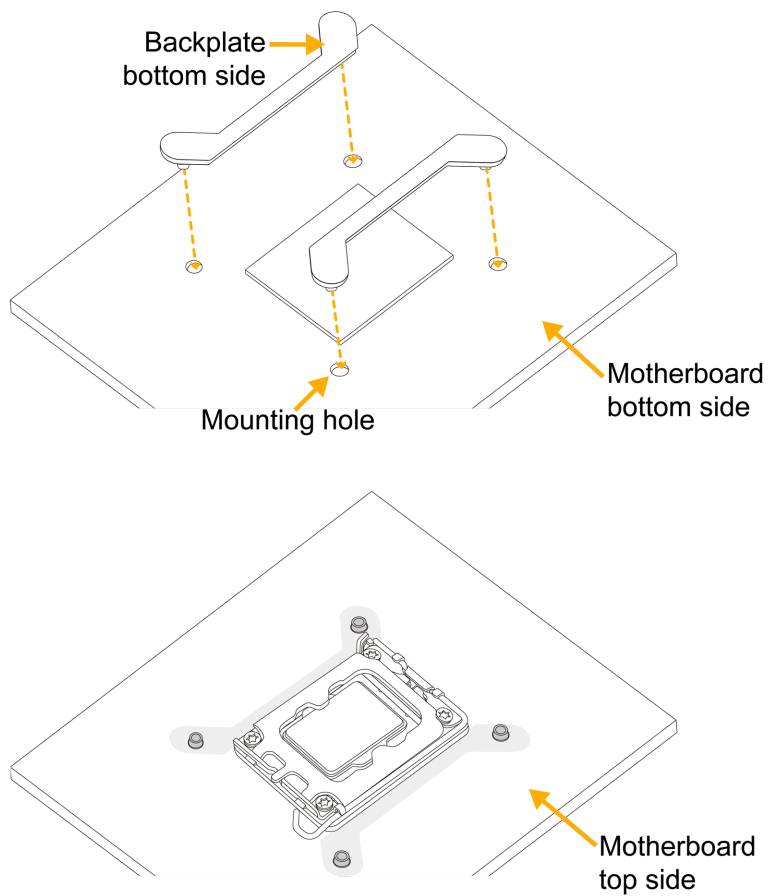

Figure 2-11. Removing the Protective Film

3. Attach the backplate into the mounting holes around the processor socket on the bottom side of the motherboard.



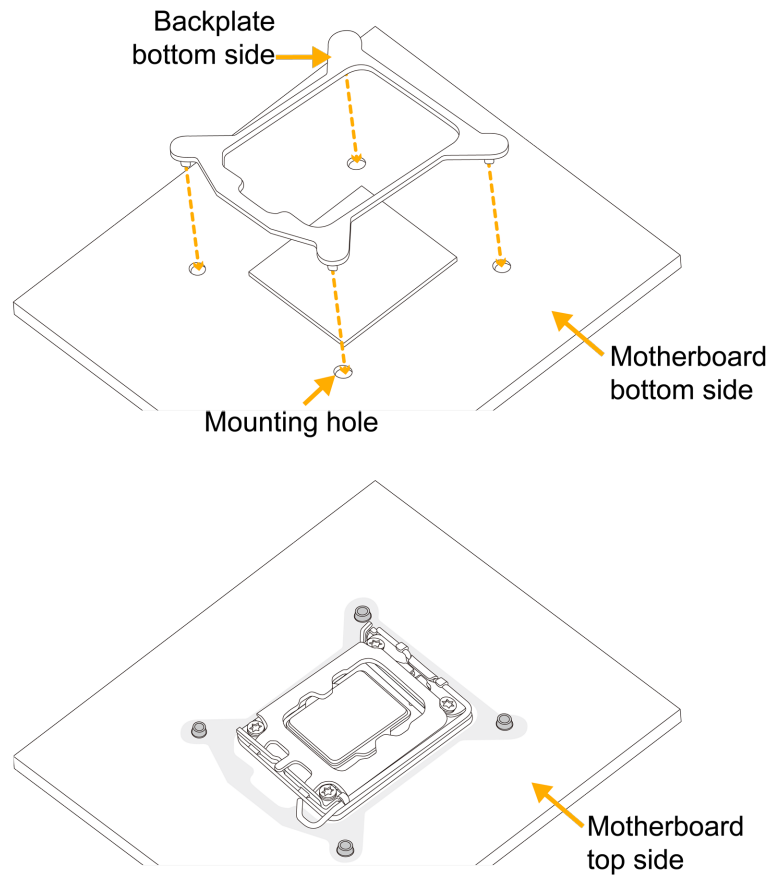

Figure 2-12. Attaching the Backplate to the Bottom Side of the Motherboard

4. Apply the proper amount of thermal grease on the processor.

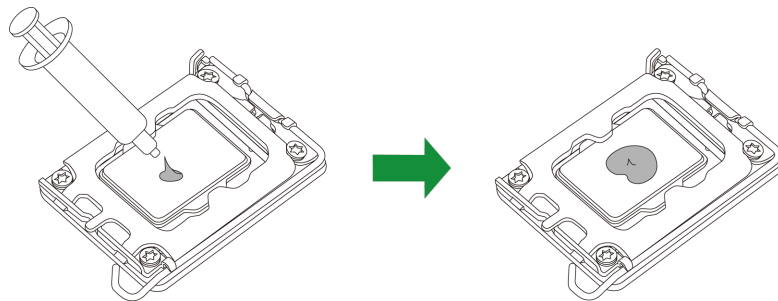
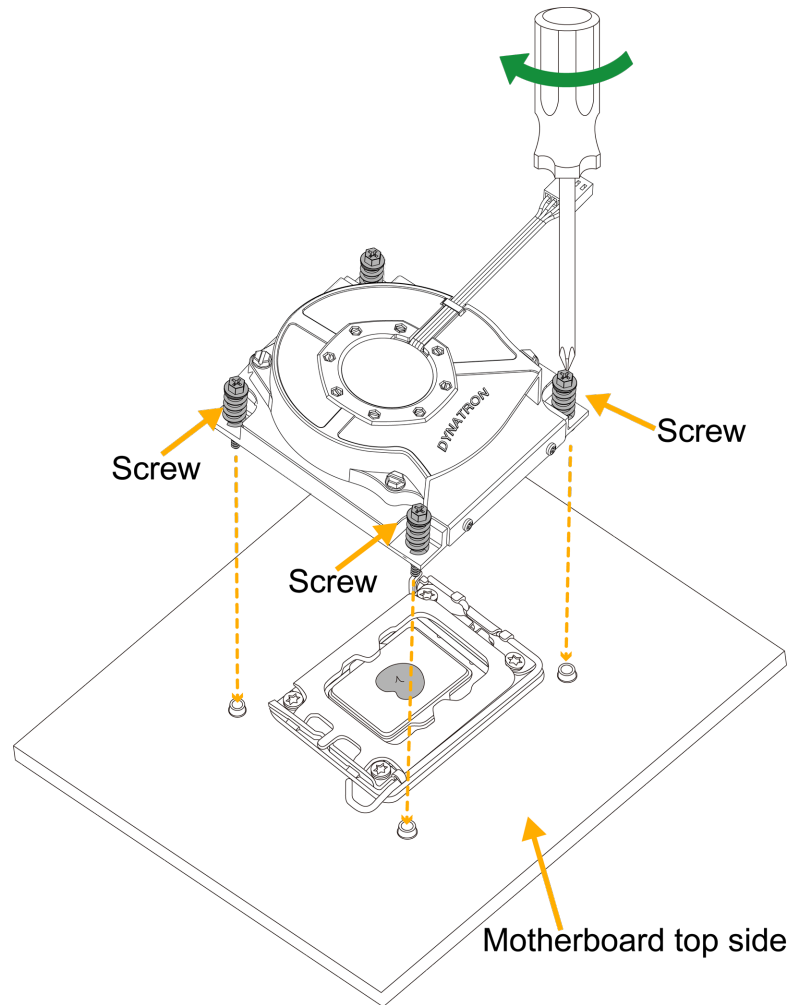

Figure 2-13. Applying Thermal Grease

5. Place the heatsink on top of the processor so that the four mounting holes on the heatsink are aligned with those on the retention mechanism.

6. Tighten the screws.

**Figure 2-14. Tightening the Heatsink Screws****Notes:**

- The installation described in this section is for reference only. The actual installation steps may vary depending on the CPU heatsink model. Refer to the heatsink instructions for more details.
- Images displayed are for illustration purposes only. Your components might look different from those shown in this manual.

Removing the Processor Heatsink

Important: We do not recommend that the processor or heatsink be removed. However, if you do need to remove the heatsink, follow the instructions below to remove the heatsink and prevent damage done to the processor or other components.

1. Unplug the power cord from the power supply and the power connector from the cooler and fan header.
2. Loosen the screws as shown in figure in the next step.
3. Gently wiggle the heatsink to loosen it. Do not use excessive force when wiggling the heatsink.

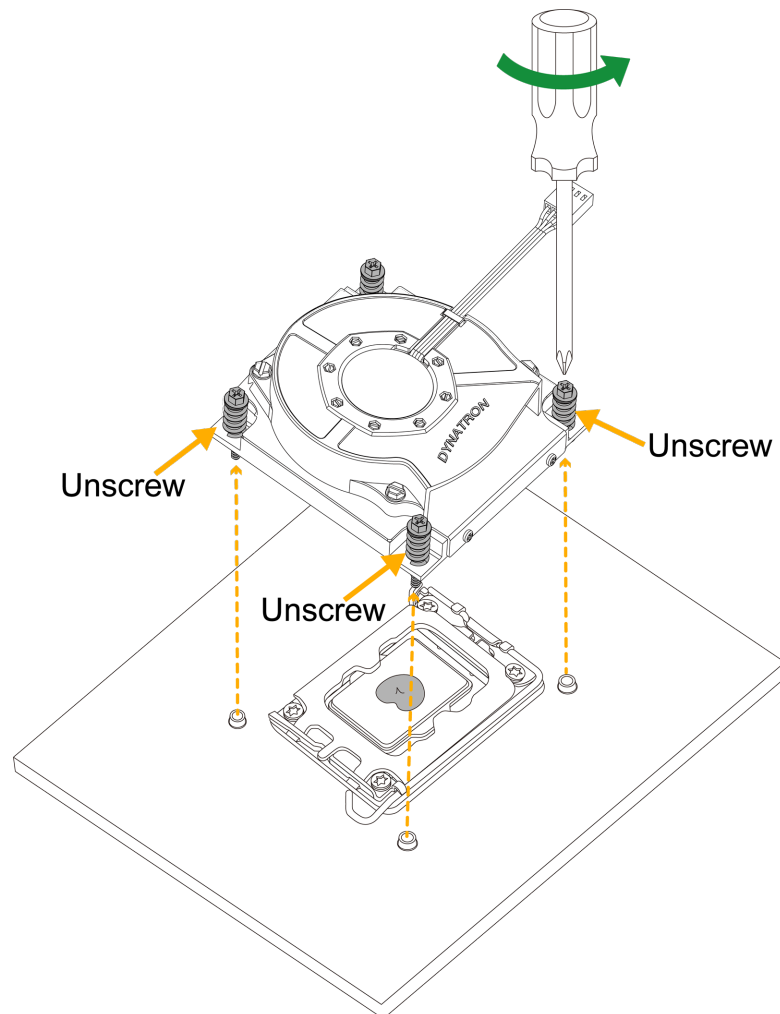

Figure 2-15. Loosening the Heatsink Screws

4. Once the heatsink is loosened, remove it from the motherboard.

2.4 Memory Support and Installation

Important: To prevent any damage, exercise extreme care when installing or removing memory modules.

Note: Check the Supermicro website for recommended memory modules.

Memory Support

The X14SAV-TLN4F supports up to 96 GB of DDR5 ECC and Non-ECC SODIMM memory with speeds of up to 5600 MT/s in two memory slots.

General Guidelines for Optimizing Memory Performance

- It is recommended to use DDR5 memory of the same type, size, and speed.
- Mixed DIMM speeds can be installed. However, all DIMMs will run at the speed of the slowest DIMM.
- The motherboard will support an odd number amount of memory modules. However, to achieve the best memory performance, a balanced memory population is recommended.

SODIMM Installation

Important: To avoid causing any damage to the memory module or the DIMM socket, do not use excessive force when pressing the release tabs on the ends of the DIMM socket. Handle memory modules with care. To avoid ESD-related damage to your memory modules or components, carefully follow all the instructions given in "[Static-Sensitive Devices](#)" on [page 30](#).

1. Install the desired number of SODIMMs into the memory slots, starting with DIMMA1 and then DIMMB1.
2. Align the key on the bottom of the SODIMM module against the receptive point on the memory slot. Take note of the notches on the side of the SODIMM module and of the locking clips on the socket to avoid causing damage.

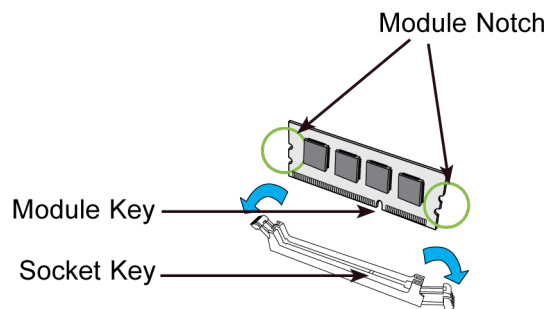

Figure 2-16. Aligning the SODIMM

3. Press the SODIMM module straight down into the socket with both hands until it is securely seated. The side clips will automatically lock the module into place.

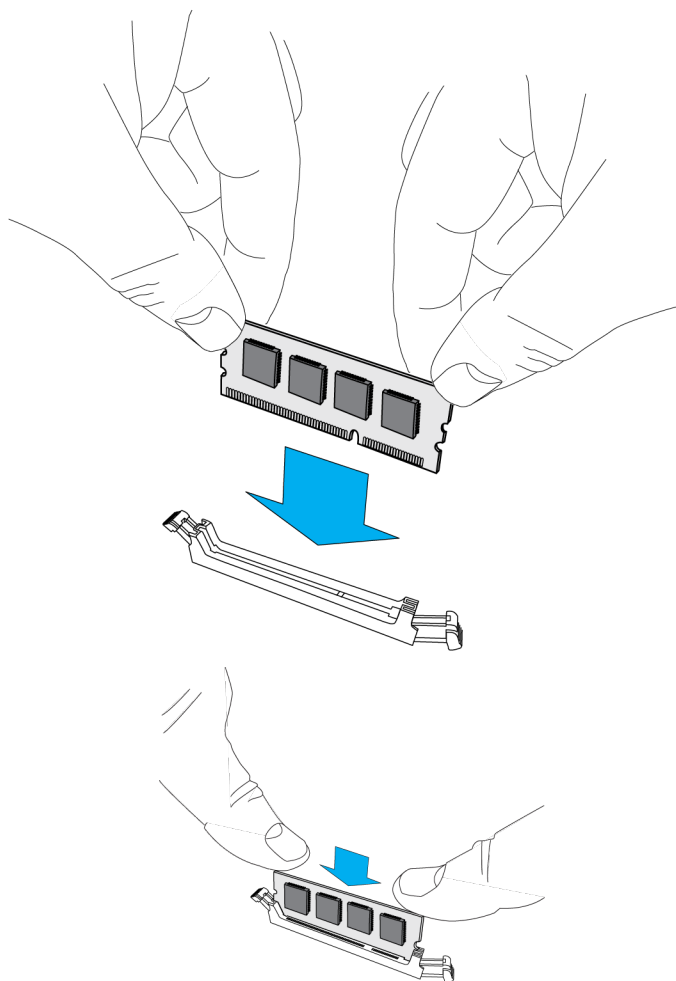

Figure 2-17. Securing the SODIMM

SODIMM Removal

Push the side clips at the end of the slot to release the SODIMM module. Pull the SODIMM module up to remove it from the slot.

For a detailed diagram of the X14SAV-TLN4F/F motherboard, see the layout under "[Quick Reference](#)" on page 13.

2.5 Battery Removal and Installation

Battery Removal

To remove the battery, follow the steps below:

1. Power off your system and unplug your power cable.
2. Remove the battery cable at the BT1 connector on the board.
3. Remove the battery.

Proper Battery Disposal



Warning! Handle used batteries carefully. Do not damage the battery in any way; a damaged battery may release hazardous materials into the environment. Do not discard a used battery in the garbage or a public landfill. Comply with the regulations set up by your local hazardous waste management agency to dispose of your used battery properly.

Battery Installation

To install an battery, follow steps 1 and 2 above and continue below:

1. Connect the battery cable into the battery connector (BT1) and push it down until you hear a click to ensure that the cable is securely locked.
2. Use the foam tape on the back side of the battery to secure it to a flat surface on the bottom of the motherboard or a proper location in the system. Do not place the battery on the heatsink.



Warning! When replacing a battery, be sure to only replace it with the same type.

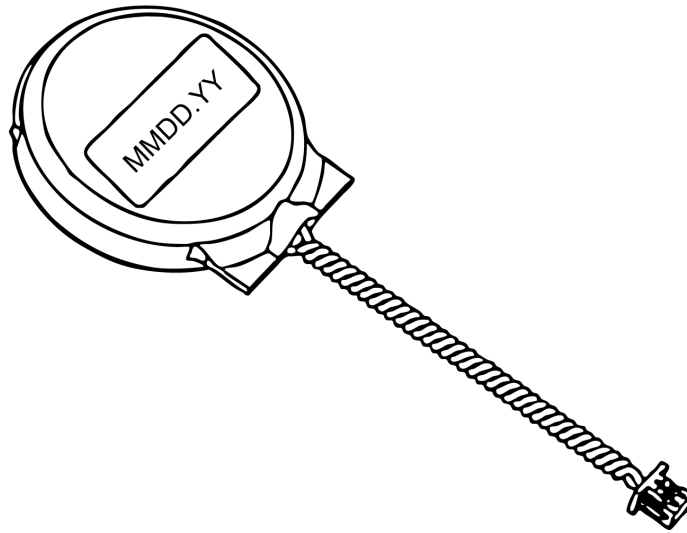

Figure 2-18. Battery

Input/Output Ports

For information about input/output ports on the X14SAV-TLN4F/F motherboard, refer to the following content.

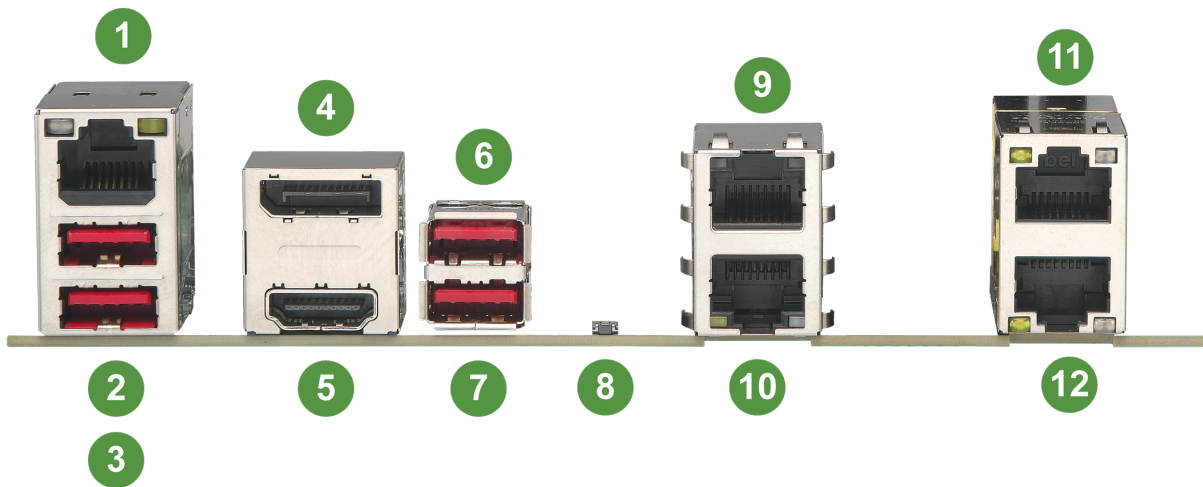

Figure 2-19. X14SAV-TLN4F I/O Ports

X14SAV-TLN4F I/O Ports					
#	Description	#	Description	#	Description
1	BMC LAN Port	5	HDMI 2.1 Port	9	LAN1 (2.5G)

X14SAV-TLN4F I/O Ports					
#	Description	#	Description	#	Description
2	USB4 (3.2, 10 Gb)	6	USB2 (3.2, 10 Gb)	10	LAN2 (2.5G)
3	USB5 (3.2, 10 Gb)	7	USB3 (3.2, 10 Gb)	11	LAN3 (10G) (on - TLN4F only)
4	DisplayPort	8	UID Button	12	LAN4 (10G) (10G) (on - TLN4F only)

HDMI and DP Ports

One High Definition Multimedia Interface (HDMI) port is included on the I/O port. This port is used to display both high definition video and digital sound through an HDMI-capable display. HDMI 2.1 allows faster frame rates and is backward compatible with previous HDMI versions. This port provides Intel HD graphics digital output with a resolution up to 4096 x 2160 at 60 Hz refresh rate with HDR. There is also one DP port included on the I/O port. These ports deliver digital display and fast refresh rate. They can connect to virtually any display device using a DisplayPort adapter for devices such as VGA, DVI, or HDMI.

For a detailed diagram of the X14SAV-TLN4F/F motherboard, see the layout under "[Quick Reference](#)" on page 13.

LAN Ports

Two 2.5G (JLAN1) LAN ports and two 10G (JLAN2) LAN ports are located on the I/O ports. There is also one BMC LAN port on the I/O ports. These ports accept RJ45 cables.

For a detailed diagram of the X14SAV-TLN4F/F motherboard, see the layout under "[Quick Reference](#)" on page 13.

Unit Identifier Button

A Unit Identifier (UID) button and two LED indicators are located on the motherboard. The UID button is located near the I/O ports of the X14SAV-TLN4F/F motherboard.

Note: After pushing and holding the UID button for 12 seconds, all BMC settings including username and password will revert back to the factory default. Only the network settings and FRU are retained.

For a detailed diagram of the X14SAV-TLN4F/F motherboard, see the layout under "[Quick Reference](#)" on page 13.

Function	User Input	Behavior	LED Activity
UID LED Indicator	Push once Push again	Turns on the UID LED Turns off the UID LED	UID LED turns solid blue UID LED turns off
BMC Reset	Push and hold for 6 seconds Push and hold for 12 seconds	BMC will do a cold boot BMC will reset to factory default	BMC Heartbeat LED turns solid green BMC Heartbeat LED turns solid green

UID Button Pin Definitions: Four Total		UID LED Pin Definitions: Four Total	
Pin#	Definition	Pin#	Status
1	Button In	1	Button In
2	GND	2	GND
G1	GND	G1	GND
G2	GND	G2	GND

USB Ports

There are four USB 3.2 ports (JUSBJ1, JUSBJ2) on the motherboard.

For a detailed diagram of the X14SAV-TLN4F/F motherboard, see the layout under ["Quick Reference"](#) on page 13.

USB 3.2 Gen 2 Ports Pin Definitions: 20 Total			
Pin#	Definition	Pin#	Definition
1	GND	11	GND
2	TX1+	12	TX2-
3	TX1-	13	TX2+
4	GND	14	GND
5	RX1+	15	RX2-
6	RX1-	16	RX2+
7	GND	17	GND
8	D1+	18	D2+

USB 3.2 Gen 2 Ports			
Pin Definitions: 20 Total			
Pin#	Definition	Pin#	Definition
9	D1-	19	D2-
10	VBUS1	20	VBUS2

Front Control Panel

JF1 on the X14SAV-TLN4F/F motherboard contains header pins for various buttons and indicators that are normally located on a control panel at the front of the chassis. These connectors are designed specifically for use with Supermicro chassis.

For a detailed diagram of the X14SAV-TLN4F/F motherboard, see the layout under ["Quick Reference"](#) on page 13.

Power Button

The Power Button connection is located on pins 1 and 2 of JF1 on the X14SAV-TLN4F/F motherboard. Momentarily contacting both pins will power on/off the system. This button can also be configured to function as a suspend button (with a setting in the BIOS). To turn off the power when the system is in suspend mode, press the button for four seconds or longer.

For a detailed diagram of the X14SAV-TLN4F/F motherboard, see the layout under ["Quick Reference"](#) on page 13.

Power Button	
Pin Definitions (JF1)	
Pin#	Definition
1	Signal
2	GND

Reset Button

The Reset Button connection is located on pins 3 and 4 of JF1 on the X14SAV-TLN4F/F motherboard. Attach it to a hardware reset switch on the computer case to reset the system.

For a detailed diagram of the X14SAV-TLN4F/F motherboard, see the layout under ["Quick Reference"](#) on page 13.

Reset Button	
Pin Definitions (JF1)	
Pin#	Definition
3	Reset
4	GND

Overheat/Fan Fail LED

Connect an LED cable to pins 7 and 8 of the Front Control Panel to use the UID LED and Overheat/Fan Fail LED connections. Attach a cable to pin 7 to use the UID button. The LED on pin 8 provides warnings of overheat or fan failure.

For a detailed diagram of the X14SAV-TLN4F/F motherboard, see the layout under "[Quick Reference](#)" on page 13.

OH/Fan Fail Indicator Status		UID and OH-FAN Fail LED	
Pin Definitions (JF1)		Pin Definitions (JF1)	
State	Definition	Pin#	Definition
Off	Normal	7	UID LED
On	Overheat	8	OH-Fan Fail LED
Flashing	Fan Fail		

NIC1/NIC2 (LAN1/LAN2)

The Network Interface Controller (NIC) LED connection for LAN port 1 is located on pins 11 and 12 of JF1 on the X14SAV-TLN4F/F motherboard, and LAN port 2 is on pins 9 and 10. Attach the NIC LED cables here to display network activity.

For a detailed diagram of the X14SAV-TLN4F/F motherboard, see the layout under "[Quick Reference](#)" on page 13.

LAN1/LAN2 LED	
Pin Definitions (JF1)	
Pin#	Definition
9	+3.3 V Stby
10	NIC2 Link/Active LED
11	+3.3 V Stby
12	NIC1 Link/Active LED

HDD LED

The HDD LED connection is located on pins 13 and 14 of JF1 on the X14SAV-TLN4F/F motherboard. Attach a cable to pin 14 to show storage drive activity status.

For a detailed diagram of the X14SAV-TLN4F/F motherboard, see the layout under ["Quick Reference" on page 13](#).

HDD LED	
Pin Definitions (JF1)	
Pin#	Definition
13	+3.3 V
14	HDD LED

Power LED

The Power LED connection is located on pins 15 and 16 of JF1 on the X14SAV-TLN4F/F motherboard.

For a detailed diagram of the X14SAV-TLN4F/F motherboard, see the layout under ["Quick Reference" on page 13](#).

Power LED	
Pin Definitions (JF1)	
Pin#	Definition
15	+3.3 V Stby
16	PWR LED

NMI Button

The non-maskable interrupt (NMI) button header is located on pins 19 and 20 of JF1 on the X14SAV-TLN4F/F motherboard.

For a detailed diagram of the X14SAV-TLN4F/F motherboard, see the layout under ["Quick Reference" on page 13](#).

NMI Button	
Pin Definitions (JF1)	
Pin#	Definition
19	Control

NMI Button	
Pin Definitions (JF1)	
Pin#	Definition
20	GND

2.6 Connections, Jumpers, and LEDs

Refer to the following sections for information about connections, jumpers, and LEDs for the X14SAV-TLN4F/F motherboard.

Power Supply and Power Connections

For information about the power supply and power connections of the X14SAV-TLN4F/F motherboard, refer to the following content.

Power Supply

As with all computer products, a stable power source is necessary for proper and reliable operation. It is even more important for processors that have high CPU clock rates where noisy power transmission is present.

The X14SAV-TLN4F/F motherboard supports both +12 V DC and ATX power input. Either option requires an 8-pin +12 V connection to the JPV1 header, with an ATX power signal input requiring an additional connection using PN: CBL-PWEX-1063/1066 between header JPV1 and the 24-pin power connector of an ATX power supply. JPV1 allows motherboard control of the +5 V Stby, power on, power good, and ground signals from the ATX power supply.

It is strongly recommended that you use a high quality power supply that meets ATX power supply Specification 2.02 or above.

4-Pin HDD Power Connector

JPH1 is 4-pin power connector that provides power to onboard HDD devices.

For a detailed diagram of the X14SAV-TLN4F/F motherboard, see the layout under "[Quick Reference](#)" on page 13.

4-pin HDD Power	
Pin Definitions: Four Total	
Pin#	Definition
1	+12 V
2	GND
3	GND
4	+5 V

4-pin DC Power Source

JPW1 is a necessary connection to the 24-pin ATX power header from the PSU via PN: CBL-PWEX-1066.

For a detailed diagram of the X14SAV-TLN4F/F motherboard, see the layout under "[Quick Reference](#)" on page 13.

4-pin DC Power Source	
Pin Defintions: Four Total	
Pin#	Definition
1	P5VSB
2	GND
3	ATX_PWRGD
4	PSU_PSON_N

8-pin DC Power Connector

JPV1 is an 8-pin 12 V DC power input for the processor that must be connected to the power supply.

For a detailed diagram of the X14SAV-TLN4F/F motherboard, see the layout under "[Quick Reference](#)" on page 13.

8-pin DC Power	
Pin Definitions: Eight Total	
Pin#	Definition
1-4	GND
5-8	+12 V (12 V Power)

Headers and Connections

For information about the headers on the X14SAV-TLN4F/F motherboard, refer to the following content.

Chassis Intrusion

A Chassis Intrusion header is located at JL1 on the X14SAV-TLN4F/F motherboard. Attach the appropriate cable from the chassis to inform you when the chassis is opened.

For a detailed diagram of the X14SAV-TLN4F/F motherboard, see the layout under "[Quick Reference](#)" on page 13.

Chassis Intrusion	
Pin Definitions: Two Total	
Pin#	Definition
1	Intrusion Input
2	GND

CMOS Battery

BT1 is a 2-pin connector for an external CMOS battery. This connector is also used to clear the CMOS. To clear the CMOS, remove the battery, short pins 1–2 for more than 10 seconds and then install the battery.

For a detailed diagram of the X14SAV-TLN4F/F motherboard, see the layout under "[Quick Reference](#)" on page 13.

COM Header

There is one COM header on the X14SAV-TLN4F/F motherboard. Use a cable with the COM header to access the COM port. COM ports provide serial communication support.

For a detailed diagram of the X14SAV-TLN4F/F motherboard, see the layout under "[Quick Reference](#)" on page 13.

COM Header			
Pin Definitions: 10 Total			
Pin#	Definition	Pin#	Definition
1	SP_DCD1	2	SP_DSR1
3	SP_RXD1	4	SP_RTS1
5	SP_TXD1	6	SP_CTS1
7	SP_DTR1	8	SP_RI1
9	GND	10	NC

External BMC I²C Header

A System Management Bus header for the BMC is located at JIPMB1 on the X14SAV-TLN4F/F motherboard. Connect the appropriate cable here to use the IPMB I²C connection on your system.

For a detailed diagram of the X14SAV-TLN4F/F motherboard, see the layout under "[Quick Reference](#)" on page 13.

External I ² C Header	
Pin Definitions: Four Total	
Pin#	Definition
1	Clock
2	GND
3	Data
4	NC

Fan Headers

There are three 4-pin fan headers (FAN1–FAN3) on the X14SAV-TLN4F/F motherboard. All the 4-pin fan headers are backwards compatible with the traditional 3-pin fans. However, fan speed control is available by Thermal Management via the IPMI 2.0 interface.

For a detailed diagram of the X14SAV-TLN4F/F motherboard, see the layout under "[Quick Reference](#)" on page 13.

4-pin Fan Header	
Pin Definitions: Four Total	
Pin#	Definition
1	GND (Black)
2	+12 V (Red)
3	Tachometer
4	PWM Control

M.2 Slots

Two M.2 slots are located on the X14SAV-TLN4F/F motherboard. M.2 was formerly known as Next Generation Form Factor (NGFF) and serves to replace mini PCIe. M.2 allows for a variety of card sizes, increased functionality, and spatial efficiency. The M.2 M-Key slot on the motherboard supports PCIe 5.0 x4 devices. The M.2 B-Key slot supports PCIe 4.0 and USB 3.0 devices.

For a detailed diagram of the X14SAV-TLN4F/F motherboard, see the layout under "[Quick Reference](#)" on page 13.

M.2 B-Key			
Pin Definitions: 75 Total			
Pin#	Definition	Pin#	Definition
1	No Connection	2	+3.3 VSB
3	GND	4	+3.3 VSB
5	GND	6	FULL_CARD_POWER_OFF# (PU to P1V8SB only)
7	USB_D+	8	W_DISABLE1#(PU to +3.3 VSB only)
9	USB_D-	10	LED_N
11	GND	12	KEY B
13	KEY B	14	KEY B
15	KEY B	16	KEY B
17	KEY B	18	KEY B
19	KEY B	20	PCIE_DIS
21	No Connection	22	VBUS_SENSE
23	WAKE_ON_WWAN#(PU to +1.8 VSB)	24	No Connection
25	No Connection	26	W_DISABLE2#(PU to +1.8 VSB only)
27	GND	28	No Connection
29	USB3.0-RX- / PERn1	30	UIM-RESET
31	USB3.0-Rx + / PERp1	32	UIM-CLK
33	GND	34	UIM-DATA
35	USB3.0-Tx- /PETn1	36	UIM-PWR
37	USB3.0-Tx+ / PETp1	38	No Connection
39	GND	40	No Connection
41	PERn0	42	No Connection
43	PERp0	44	Alert# (PU to +1.8 VSB only)
45	GND	46	No Connection
47	PETn0	48	No Connection
49	PETp0	50	PERST#
51	GND	52	CLKRED#
53	REFCLKn	54	PEWAKE#
55	REFCLKp	56	No Connection

M.2 B-Key			
Pin Definitions: 75 Total			
Pin#	Definition	Pin#	Definition
57	GND	58	No Connection
59	No Connection	60	No Connection
61	No Connection	62	No Connection
63	No Connection	64	No Connection
65	No Connection	66	SIM_DETECT
67	RESET#	68	No Connection
69	No Connection	70	SUSCLK
71	GND	72	+3.3 VSB
73	GND	74	+3.3 VSB
75	No Connection		

M.2 M-Key			
Pin Definitions: 75 Total			
Pin#	Definition	Pin#	Definition
1	GND	2	+3.3 V
3	GND	3	+3.3 V
5	PERn3	6	No Connection
7	PERp3	8	No Connection
9	GND	10	LED_N
11	PETn3	12	+3.3 V
13	PETp3	14	+3.3 V
15	GND	16	+3.3 V
17	PERn2	18	+3.3 V
19	PERp2	20	No Connection
21	GND	22	No Connection
23	PETn2	24	No Connection
25	PETp2	26	No Connection
27	GND	28	No Connection

M.2 M-Key			
Pin Definitions: 75 Total			
Pin#	Definition	Pin#	Definition
29	PERn1	30	No Connection
31	PERp1	32	No Connection
33	GND	34	No Connection
35	PETn1	36	No Connection
37	PETp1	38	No Connection
39	GND	40	SCL
41	PERn0	42	SDA
43	PERp0	44	SMB_ALERT
45	GND	46	No Connection
47	PETn0	48	No Connection
49	PETp0	50	PERST#
51	GND	52	CLKREQ#
53	REFCLKn	54	PCle_wake
55	REFCLKp	56	No Connection
57	GND	58	No Connection
59	KEY M	60	KEY M
61	KEY M	62	KEY M
63	KEY M	64	KEY M
65	KEY M	66	KEY M
67	No Connection	68	SUSCLK
69	PEDET	70	+3.3 V
71	GND	72	+3.3 V
73	GND	74	+3.3 V
75	GND		

MCIO PCIe 4.0 x8 Connector

One internal MCIO PCIe 4.0 x8 connector is located at JNVME1 on the motherboard for high-performance storage connectivity through the NVMe interface or for additional SATA storage.

For a detailed diagram of the X14SAV-TLN4F/F motherboard, see the layout under ["Quick Reference"](#) on page 13.

MCIO PCIe 4.0 x4 Connector

One internal MCIO PCIe 4.0 x4 connector is located at JNVME2 on the motherboard for high-performance storage connectivity through the NVMe interface or for additional SATA storage.

Depending on the setting through the JNS1 jumper, the MCIO PCIe 4.0 x4 connector can be utilized as PCIe x4/SATA ports or a single U.2 NVMe port. NVMe provides lower data latency for increased efficiency and storage performance.

For a detailed diagram of the X14SAV-TLN4F/F motherboard, see the layout under ["Quick Reference"](#) on page 13.

Power SMB (I²C) Header

The Power System Management Bus (I²C) connector on the X14SAV-TLN4F/F motherboard monitors the power supply, fan, and system temperatures.

For a detailed diagram of the X14SAV-TLN4F/F motherboard, see the layout under ["Quick Reference"](#) on page 13.

Power SMBus Header	
Pin Definitions: Five Total	
Pin#	Definition
1	Clock
2	Data
3	PMBUS_Alert
4	GND
5	+3.3 V

Power SMB Header

The Power System Management Bus header for additional slave devices is located at JSMB1.

For a detailed diagram of the X14SAV-TLN4F/F motherboard, see the layout under ["Quick Reference"](#) on page 13.

Power SMBus Header	
Pin Definitions: Three Total	
Pin#	Definition
1	Data

Power SMBus Header	
Pin Definitions: Three Total	
Pin#	Definition
2	GND
3	Clock

Speaker Header

On the JD1 header, close pins 3 and 4 with a cap to use the onboard buzzer. If you wish to use an external speaker, close pins 1-4 with a cable.

For a detailed diagram of the X14SAV-TLN4F/F motherboard, see the layout under "[Quick Reference](#)" on page 13.

Buzzer/External Speaker	
Pin Definitions: Four Total	
Pin#	Definition
Pins 1–4	Speaker

TPM/Port 80 Header

The JTPM1 header on the X14SAV-TLN4F/F motherboard is used to connect a Trusted Platform Module (TPM)/Port 80, which is available from Supermicro (optional). A TPM/Port 80 connector is a security device that supports encryption and authentication in hard drives. It allows the motherboard to deny access if the TPM associated with the storage drive is not installed in the system. Go to the following link for more information on the TPM: https://www.supermicro.com/manuals/other/AOM-TPM-9670V_9670H_X12_H12.pdf.

For a detailed diagram of the X14SAV-TLN4F/F motherboard, see the layout under "[Quick Reference](#)" on page 13.

Trusted Platform Module Header			
Pin Definitions: 10 Total			
Pin#	Definition	Pin#	Definition
1	+3.3 V	2	SPI_CS#
3	RESET#	4	SPI_MISO
5	SPI_CLK	6	GND
7	SPI_MOSI	8	No Connection
9	+3.3 V Stdbby	10	SPI_IRQ#

VGA Header

A video (VGA) header is located on the motherboard and is used with an optional VGA cable (OTHR-1062A-10). The VGA header provides analog interface support between the computer and the video displays.

For a detailed diagram of the X14SAV-TLN4F/F motherboard, see the layout under "[Quick Reference](#)" on page 13.

USB Headers

The motherboard has one USB 3.2 header (JUSB2) and one USB 2.0 header (USB0/1). The onboard headers can be used to provide front side USB access with a cable (not included).

For a detailed diagram of the X14SAV-TLN4F/F motherboard, see the layout under "[Quick Reference](#)" on page 13.

(USB 2.0) Header			
Pin Definitions: 10 Total			
Pin#	Definition	Pin#	Definition
1	+5 V	2	+5 V
3	USB_N	4	USB_N
5	USB_P	6	USB_P
7	GND	8	GND
9	Key	10	No Connection

(USB 3.2 Gen 1) Header			
Pin Definitions: 20 Total			
Pin#	Definitions	Pin#	Definitions
1	VBUS	11	IntA_P2_D+
2	IntA_P1_SSRX-	12	IntA_P2_D-
3	IntA_P1_SSRX+	13	GND
4	GND	14	IntA_P2_SSTX+
5	IntA_P1_SSTX-	15	IntA_P2_SSTX-
6	IntA_P1_SSTX+	16	GND
7	GND	17	IntA_P2_SSRX+
8	IntA_P1_D-	18	IntA_P2_SSRX-
9	IntA_P1_D+	19	VBUS

(USB 3.2 Gen 1) Header			
Pin Definitions: 20 Total			
Pin#	Definitions	Pin#	Definitions
10	GND	20	No Connection

Jumper Settings

To modify the operation of the motherboard, jumpers can be used to choose between optional settings. Jumpers create shorts between two pins to change the function of the connector. Pin 1 is identified with a square solder pad on the printed circuit board. See the diagram below for an example of jumping pins 1 and 2. Refer to the motherboard layout page for jumper locations.

Note: On two-pin jumpers, "Closed" means the jumper is on and "Open" means the jumper is off the pins.

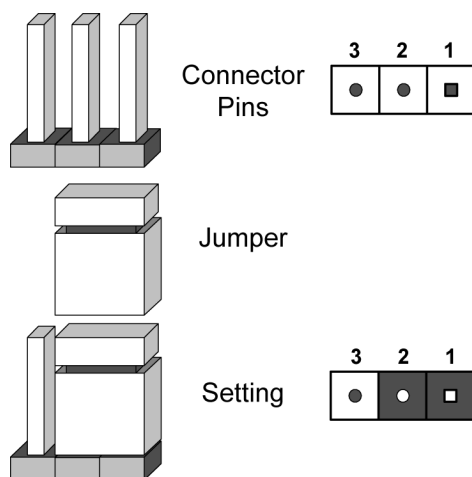

Figure 2-20. Jumping Connector Pins

CMOS Clear

JBT1 on the X14SAV-TLN4F/F motherboard is used to clear CMOS, which will also clear any passwords. Instead of pins, this jumper consists of contact pads to prevent accidentally clearing the contents of CMOS.

For a detailed diagram of the X14SAV-TLN4F/F motherboard, see the layout under "[Quick Reference](#)" on page 13.



1. Power down the system.
2. Unplug the power cord(s).
3. Remove the cover of the chassis to access the motherboard.
4. Remove the onboard battery from the motherboard.
5. Short the CMOS pads, JBT1, with a metal object such as a small screwdriver for at least four seconds.

Note: Clearing CMOS will also clear all passwords.

6. Remove the screwdriver or shorting device.
7. Reinsert the battery.
8. Replace the cover.
9. Reconnect the power cord(s).
10. Power on the system.

LAN1 Enable/Disable

Use JPL1 to enable or disable LAN on the X14SAV-TLN4F/F. The default setting is Enabled.

For a detailed diagram of the X14SAV-TLN4F/F motherboard, see the layout under "[Quick Reference](#)" on page 13.

LAN1 Enable/Disable	
Jumper Settings	
Jumper Setting	Definition
Pins 1–2	Enabled (Default)
Pins 2–3	Disabled

LAN2 Enable/Disable

Use JPL2 to enable or disable LAN on the X14SAV-TLN4F/F. The default setting is Enabled.

For a detailed diagram of the X14SAV-TLN4F/F motherboard, see the layout under "[Quick Reference](#)" on page 13.

LAN2 Enable/Disable	
Jumper Settings	
Jumper Setting	Definition
Pins 1–2	Enabled (Default)
Pins 2–3	Disabled

ME Manufacturing Mode

Close pins 2–3 of jumper JPME2_CPU1 and JPME_PCH1 to bypass SPI flash security and force the system to operate in the manufacturing mode, which will allow the user to flash the system firmware from a host server for system setting modifications. Refer to the table below for jumper settings. The default setting is Normal.

For a detailed diagram of the X14SAV-TLN4F/F motherboard, see the layout under "[Quick Reference](#)" on page 13.

ME Manufacturing Mode	
Jumper Settings	
Jumper Setting	Definition
Pins 1–2	Normal (Default)
Pins 2–3	Manufacturing Mode

PCIe Bifurcation

Use JRF1 and JRF2 to adjust the PCIe lane options on the PCIe slot. The options are x16 or x8x8.

For a detailed diagram of the X14SAV-TLN4F/F motherboard, see the layout under "[Quick Reference](#)" on page 13.

PCIe Bifurcation		
Jumper Settings		
JRF1	JRF2	PEG
Pins 2–3	Pins 2–3	x16 (PCIe)(Default)
Pins 2–3	Pins 1–2	2x8 (PCIe)
Pins 1–2	Pins 1–2	1x8, 2x4 (PCIe)

Onboard TPM Enable/Disable

Use JPT1 to enable or disable the onboard TPM.

For a detailed diagram of the X14SAV-TLN4F/F motherboard, see the layout under ["Quick Reference"](#) on page 13.

TPM Enable/Disable Jumper Settings	
Jumper Setting	Definition
Pins 1–2	Enabled (Default)
Pins 2–3	Disabled

SIM Detect Option

Pins 2 and 4 on the JSIM1_OPT jumper are for SIM card detection. Since each SIM card vendor sets a different condition for detection, check with the vendor for the correct detection type and set the JSIM1_OPT jumper before installing the SIM card. Pins 1 and 3 on the JSIM1_OPT jumper are for 5G/LTE USB/PCIe module detection. Check with the vendor for the correct detection type and set the JSIM1_OPT jumper before installing the module. Pins 5 and 6 on the JSIM1_OPT jumper are for enabling or disabling M.2 B-Key storage module LED signal to the front panel HDD LED. Disconnect pins 5 and 6 to disable the LED signal.

For a detailed diagram of the X14SAV-TLN4F/F motherboard, see the layout under ["Quick Reference"](#) on page 13.

SIM Detect Option Jumper Settings	
Jumper Settings	Definition
Pins 1–3	USB (Default)
Pins 1–3 Open	PCIe Low Active
Pins 2–4	SIM Detect Low Active (Default)
Pins 2–4 Open	SIM Detect High Active
Pins 5–6	M.2 B-Key Storage LED Enabled (Default)
Pins 5–6 Open	M.2 B-Key Storage LED Disabled

VGA Enable/Disable

Jumper JPG1 allows you to enable the onboard VGA connector on the X14SAV-TLN4F/F motherboard. The default setting is pins 1–2 to enable the connection.

For a detailed diagram of the X14SAV-TLN4F/F motherboard, see the layout under ["Quick Reference"](#) on page 13.

VGA Enable/Disable	
Jumper Settings	
Jumper Setting	Definition
Pins 1–2	Enabled (Default)
Pins 2–3	Disabled

Watchdog Timer

Watchdog (JWD1) is a system monitor that can reboot the system when a software application hangs. Close pins 1–2 to reset the system if an application hangs. Close pins 2–3 to generate a non-maskable interrupt (NMI) signal for the application that hangs. The watchdog must also be enabled in the BIOS.

For a detailed diagram of the X14SAV-TLN4F/F motherboard, see the layout under "[Quick Reference](#)" on page 13.

Watchdog Timer	
Jumper Settings	
Jumper Setting	Definition
Pins 1–2	Reset (Default)
Pins 2–3	NMI
Open	Disabled

LED Indicators

For information about the LED indicators on the X14SAV-TLN4F/F motherboard, refer to the following content.

BMC Heartbeat LED

A BMC Heartbeat LED is located at LED3 on the X14SAV-TLN4F/F motherboard. When this LED is blinking, the BMC is functioning normally.

For a detailed diagram of the X14SAV-TLN4F/F motherboard, see the layout under "[Quick Reference](#)" on page 13.

BMC Heartbeat LED Indicator	
LED Color	Definition
Orange: Blinking	BMC Normal

Power LED

The Power LED is located on the X14SAV-TLN4F/F motherboard. When this LED is on, power is present on the motherboard. In suspend mode, this LED will blink on and off. Be sure to turn off the system and unplug the power cord before removing or installing components.

For a detailed diagram of the X14SAV-TLN4F/F motherboard, see the layout under "[Quick Reference](#)" on page 13.

Power LED Indicator	
LED Color	Definition
Blinking	S3 Status
Green	Power On

Unit ID (UID) LED

The front UID LED indicator is located UID_LED1 on the X14SAV-TLN4F/F motherboard. This UID indicator provides easy identification of a system that may need services.

For a detailed diagram of the X14SAV-TLN4F/F motherboard, see the layout under "[Quick Reference](#)" on page 13.

UID LED LED Indicator	
LED Color	Definitions
Blue: On	System Identified

Chapter 3:

Troubleshooting

The following content contains information on common issues and how to resolve them.

3.1 Troubleshooting Procedures	70
Before Power On	70
No Power	70
No Video	70
System Boot Failure	70
Memory Errors	71
Losing the System's Setup Configuration	71
If the System Becomes Unstable	71
3.2 Technical Support Procedures	73
3.3 Motherboard Battery	74
3.4 Where to Get Replacement Components	75
3.5 Returning Merchandise for Service	76
3.6 Feedback	77

3.1 Troubleshooting Procedures

Use the following procedures to troubleshoot your system. If you have followed all of the procedures below and still need assistance, refer to the ["Technical Support Procedures" on page 73](#) or ["Returning Merchandise for Service" on page 76](#) section(s) in this chapter. Always disconnect the AC power cord before adding, changing or installing any non hot-swappable hardware components. If the below steps do not fix the setup configuration problem, contact your vendor for repairs.

Before Power On

1. Make sure that there are no short circuits between the motherboard and chassis.
2. Disconnect all ribbon/wire cables from the motherboard, including those for the keyboard and mouse.
3. Remove all add-on cards.
4. Install the processor (making sure it is fully seated) and connect the front panel connectors to the motherboard.

No Power

1. Make sure that there are no short circuits between the motherboard and the chassis.
2. Make sure that the power connectors are properly connected.
3. Check that the 115 V/230 V switch, if available, on the power supply is properly set.
4. Turn the power switch on and off to test the system, if applicable.
5. Check the processor socket for bent pins and make sure the processor is fully seated.
6. The battery on your motherboard may be old. Check to verify that it still supplies approximately 3 VDC. If it does not, replace it with a new one.

No Video

1. If the power is on, but you do not have video, remove all add-on cards and cables.
2. Remove all memory modules and turn on the system (if the alarm is on, check the specs of memory modules, reset the memory, or try a different one).

System Boot Failure

If the system does not display Power-On-Self-Test (POST) or does not respond after the power is turned on, do the following:

1. Check the screen for an error message.
2. Clear the CMOS settings by unplugging the power cord and contacting both pads on the CMOS clear jumper. Restart the system. Refer to ["CMOS Clear" on page 63](#).
3. Remove all components from the motherboard and turn on the system with only one DIMM installed. If the system boots, turn off the system and repopulate the components back into the system to retest. Add one component at a time to isolate which one may have caused the system boot issue.

Memory Errors

When suspecting faulty memory is causing the system issue, check the following:

1. Make sure that the memory modules are compatible with the system and are properly installed. See ["Component Installation" on page 28](#) for installation instructions. (For memory compatibility, refer to the "Tested Memory List" link on the motherboard's product page to see a list of supported memory.)
2. Check if different speeds of DIMMs have been installed. It is strongly recommended that you use the same RAM type and speed for all DIMMs in the system.
3. Make sure that you are using the correct type of DIMMs recommended by the manufacturer.
4. Check for bad DIMMs or slots by swapping a single module among all memory slots and check the results.

Losing the System's Setup Configuration

1. Make sure that you are using a high-quality power supply. A poor-quality power supply may cause the system to lose the CMOS setup information. Refer to ["Introduction" on page 12](#) for details on recommended power supplies.
2. The battery on your motherboard may be old. Check to verify that it still supplies approximately 3 VDC. If it does not, replace it with a new one.

If the System Becomes Unstable

If the system becomes unstable during or after OS installation, check the following:

1. Processor/BIOS support: Make sure that your processor is supported and that you have the latest BIOS installed in your system.

2. Memory support: Make sure that the memory modules are supported. Refer to the product page on our website at <https://www.supermicro.com>. Test the modules using memtest86 or a similar utility.

Note: Click on the "Tested Memory List" link on the motherboard's product page to see a list of supported memory.

3. Storage Drive support: Make sure that all storage drives work properly. Replace the failed storage drives with good ones.
4. System cooling: Check the system cooling to make sure that all heatsink fans and processor/system fans, etc., work properly. Check the hardware monitoring settings in the IPMI to make sure that the processor and system temperatures are within the normal range. Also, check the front panel Overheat LED and make sure that it is not on.
5. Adequate power supply: Make sure that the power supply provides adequate power to the system. Make sure that all power connectors are connected. Refer to our website for more information on the minimum power requirements.
6. Proper software support: Make sure that the correct drivers are used.

If the system becomes unstable before or during OS installation, check the following:

1. Source of installation: Make sure that the devices used for installation are working properly, including boot devices such as a USB flash or media device.
2. Cable connection: Check to make sure that all cables are connected and working properly.
3. Use the minimum configuration for troubleshooting: Remove all unnecessary components (starting with add-on cards first), and use the minimum configuration (but with the processor and a memory module installed) to identify the trouble areas. Refer to the steps listed above in this section for proper troubleshooting procedures.
4. Identify bad components by isolating them: If necessary, remove a component in question from the chassis, and test it in isolation to make sure that it works properly. Replace a bad component with a good one.
5. Check and change one component at a time instead of changing several items at the same time. This will help isolate and identify the problem.
6. To find out if a component is good, swap this component with a new one to see if the system will work properly. If so, then the old component is bad. You can also install the component in question in another system. If the new system works, the component is good and the old system has problems.

3.2 Technical Support Procedures

Before contacting Technical Support, take the following steps. Also, note that as a motherboard manufacturer, Supermicro also sells motherboards through its channels, so it is best to first check with your distributor or reseller for troubleshooting services. They should know of any possible problems with the specific system configuration that was sold to you.

1. Refer to "Troubleshooting Procedures" on page 70 or see the FAQs on our website (<https://www.supermicro.com/FAQ/index.php>) before contacting Technical Support.
2. BIOS upgrades can be downloaded from our website (https://www.supermicro.com/support/resources/bios_ipmi.php).
3. If you still cannot resolve the problem, include the following information when contacting Supermicro for technical support:
 - Motherboard model and PCB revision number
 - BIOS release date/version (This can be seen on the initial display when your system first boots up.)
 - System configuration
4. An example of a Technical Support form is on our website at <https://webpr3.supermicro.com/SupportPortal>.
5. Distributors: For immediate assistance, have your account number ready when placing a call to our Technical Support department. For Supermicro contact information, refer to "Contacting Supermicro" on page 11.

3.3 Motherboard Battery

For information on removing, disposing of, and replacing the motherboard battery of your system, refer to [Motherboard Battery Removal and Installation](#).

3.4 Where to Get Replacement Components

If you need replacement parts for your X14SAV-TLN4F/F motherboard, to ensure the highest level of professional service and technical support, purchase exclusively from our Supermicro Authorized Distributors/System Integrators/Resellers. A list can be found on the Supermicro website:

<https://www.supermicro.com>

Under the "Buy" menu, click the "Where to Buy" link.

3.5 Returning Merchandise for Service

A receipt or copy of your invoice marked with the date of purchase is required before any warranty service will be rendered. You can obtain service by calling your vendor for a Returned Merchandise Authorization (RMA) number. When returning the motherboard to the manufacturer, the RMA number should be prominently displayed on the outside of the shipping carton, and the shipping package is mailed prepaid or hand-carried. Shipping and handling charges will be applied for all orders that must be mailed when service is complete.

For faster service, RMA authorizations can be requested online at the following page:

<https://www.supermicro.com/RmaForm>

Whenever possible, repack the motherboard in the original Supermicro carton, using the original packaging material. If these are no longer available, be sure to pack the motherboard securely, using packaging material to surround the motherboard so that it does not shift within the carton and become damaged during shipping.

This warranty only covers normal consumer use and does not cover damages incurred in shipping or from failure due to the alteration, misuse, abuse or improper maintenance of products.

During the warranty period, contact your distributor first for any product problems.

3.6 Feedback

Supermicro values your feedback as we strive to improve our customer experience in all facets of our business. Email us at Techwriterteam@supermicro.com to provide feedback on our manuals.

Chapter 4:

UEFI BIOS

The following content contains information on BIOS configuration with the X14SAV-TLN4F/F motherboard.

4.1 Introduction	79
4.2 Main Setup	81
4.3 Advanced Setup Configurations	83
4.4 Event Logs	120
4.5 BMC	122
4.6 Security	126
4.7 Boot	130
4.8 Save & Exit	132
4.9 MEBx	134

4.1 Introduction

This chapter describes the AMIBIOS™ Setup utility for the motherboard. The BIOS is stored on a chip and can be easily upgraded using the UEFI script (flash.nsh), the BMC WebUI, or the SuperServer Automation Assistant (SAA) utility.

Note: Due to periodic changes to the BIOS, some settings may have been added or deleted and might not yet be recorded in this manual. Refer to the Manual Download area of our website for any changes to BIOS that may not be reflected in this manual.

Updating BIOS

It is recommended that you do not upgrade your BIOS if you are not experiencing any problems with your system. Updated BIOS files are located on our website at the following page:

https://www.supermicro.com/support/resources/bios_ipmi.php

Check our BIOS warning message and the information on how to update your BIOS on our website. Select your motherboard model and download the BIOS file to your computer. Also, check the current BIOS revision to make sure that it is newer than your BIOS before downloading.

Important: Do not shut down or reset the system while updating the BIOS to prevent possible system boot failure! Read the motherboard README file carefully before you perform the BIOS update.

To update the BIOS under the UEFI Shell, unzip the BIOS file onto a bootable USB device and then boot into the built-in UEFI Shell. For motherboards with BMC support, type "flash.nsh <BIOS filename> <BMC Username> <BMC Password>" to start the BIOS update. The flash.nsh script will invoke the SAA (EFI) tool automatically to perform the BIOS update, beginning with uploading the BIOS image to BMC. After uploading the BIOS image, the system will reboot to continue the process. The BMC will take over and continue the BIOS update in the background. The process will take 3–5 minutes. Refer to the README file for more information.

Starting the Setup Utility

To enter the BIOS Setup utility, press the <Delete> key while the system is booting-up. In most cases, the <Delete> key is used to invoke the BIOS Setup screen. There are a few cases when other hot keys are used, such as <F1>, <F2>, etc. Each main BIOS menu option is described in this manual.

The Main BIOS screen has two main frames. The left frame displays all the options that can be configured. "Grayed-out" options cannot be configured. The right frame displays the key legend. Above the key legend is an area reserved for a text message. When a BIOS submenu or item is selected in the left frame, it is highlighted in white. Often a text message will accompany it. (Note that BIOS has default text messages built in. We retain the option to include, omit, or change any of these text messages.) Settings printed in **Bold** are the default values.

A "▶" indicates a submenu. Highlighting such an item and pressing the <Enter> key open the list of settings within that submenu.

The BIOS Setup utility uses a key-based navigation system called hot keys. Most of these hot keys (<F1>, <F2>, <F3>, <F4>, <F5>, <F6>, <Enter>, <ESC>, the arrow keys, etc.) can be used at any time during the setup navigation process.

4.2 Main Setup

The Main setup screen appears when the AMI BIOS Setup utility is first entered. To return to the Main setup screen, select the Main tab at the top of the screen. The Main BIOS setup screen is shown below.

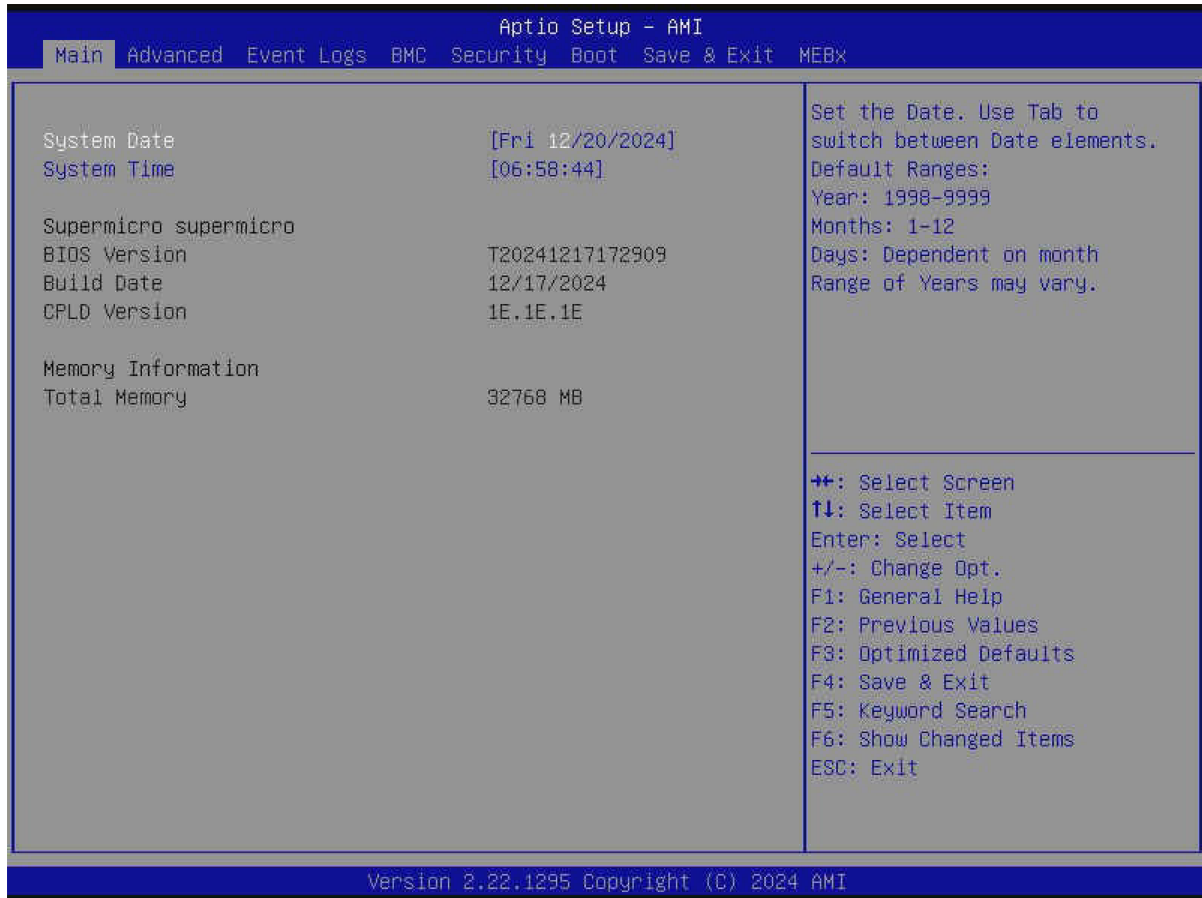

Figure 4-1. Main Setup Screen

System Date/System Time

Use the two features to change the system date and time. Highlight **System Date** or **System Time** using the arrow keys. Enter new values using the keyboard. Press the <Tab> key or the arrow keys to move between fields. The date must be entered in MM/DD/YYYY format. The time is entered in HH:MM:SS format.

Note: The time is in the 24-hour format. For example, 5:30 P.M. appears as 17:30:00.

Supermicro X14SAV-TLN4F/F

BIOS Version

This feature displays the version of the BIOS ROM used in the system.

Build Date

This feature displays the date when the version of the BIOS ROM used in the system was built.

CPLD Version

This feature displays the version of the Complex-Programmable Logical Device (CPLD) used in the system.

Memory Information**Total Memory**

This feature displays the total size of memory available in the system.

4.3 Advanced Setup Configurations

Use the arrow keys to select the Advanced submenu and press <Enter> to access the submenu items.

Important: Use caution when changing the Advanced settings. An incorrect value, an improper DRAM frequency, or a wrong BIOS timing setting may cause the system to malfunction. When this occurs, revert the settings to the default manufacturing settings.

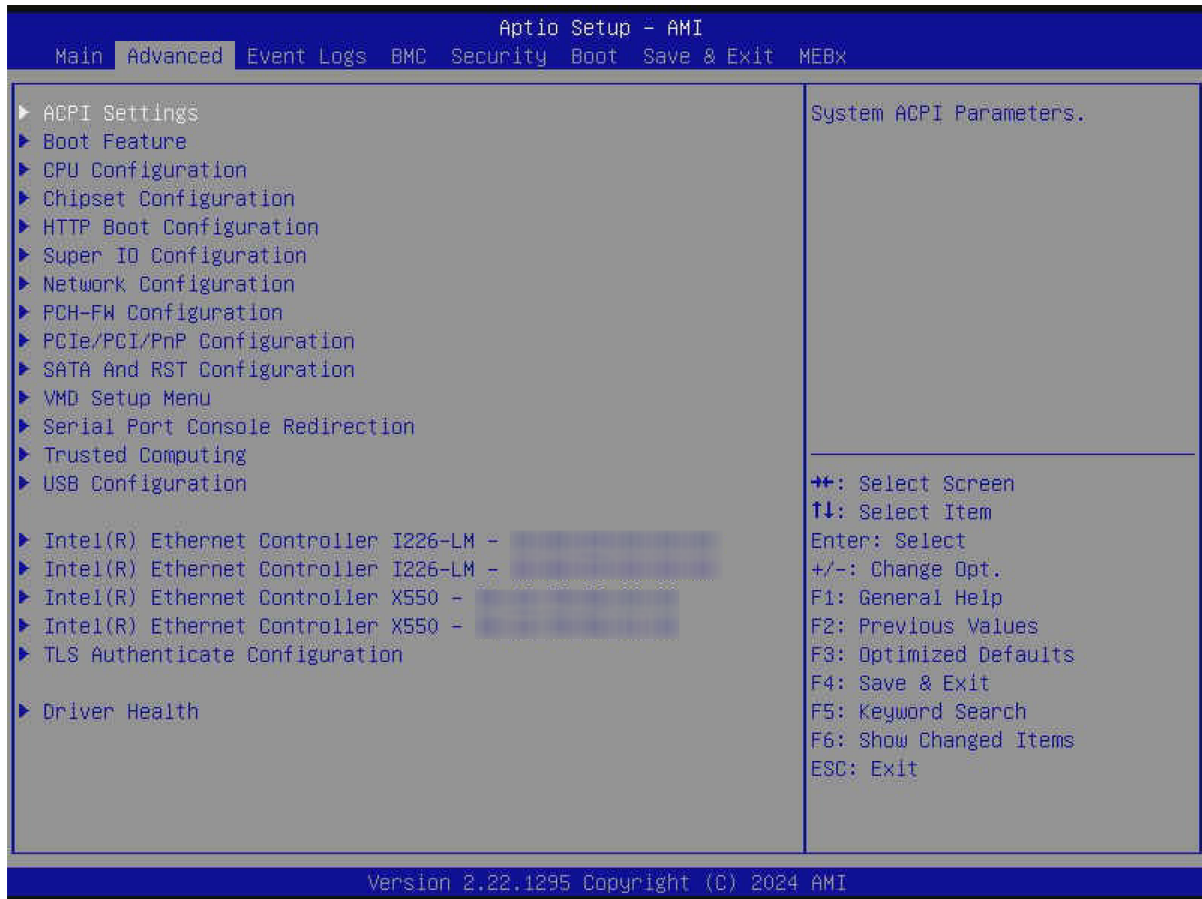

Figure 4-2. Advanced Setup Screen

ACPI Settings Menu

▶ ACPI Settings

ACPI Sleep State

Use this feature to select the ACPI Sleep State that the system will enter into when the suspend button is activated. The options are Suspend Disabled and **S3 (Suspend to RAM)**.

WHEA Support

Select Enabled to support the Windows Hardware Error Architecture (WHEA) platform. WHEA provides a common infrastructure for the system to handle hardware errors within the Windows OS environment, reducing system crashes and enhancing system recovery and health monitoring. The options are Disabled and **Enabled**.

High Precision Event Timer

Select Enabled to activate the High Precision Event Timer (HPET) that produces periodic interrupts at a much higher frequency than a Real-time Clock (RTC) does in synchronizing multimedia streams, providing smooth playback and reducing the dependency on other timestamp calculation devices, such as an x86 RDTSC Instruction embedded in the CPU. The High Performance Event Timer is used to replace the 8254 Programmable Interval Timer. The options are Disabled and **Enabled**.

Native PCIe Enable

Enable this feature to grant control of PCI Express Native hot plug, PCI Express Power Management Events, and PCI Express Capability Structure Control. The options are Disabled and **Enabled**.

Native ASPM

Select Enabled for the operating system to control the ASPM, or Disabled for the BIOS to control the ASPM. The options are Auto, Enabled, and **Disabled**.

Boot Feature Menu

► Boot Feature

Quiet Boot

Use this feature to select the screen between displaying the Power On Self Test (POST) messages or the OEM logo upon bootup. Select Disabled to display the POST messages. Select Enabled to display the OEM logo instead of the normal POST messages. The options are Disabled and **Enabled**.

Note: BIOS POST messages are always displayed regardless of the setting of this feature.

Fast Boot

This feature enables the system to boot with a minimal set of required devices to launch. This has no effect on BBS boot options. The options are **Disabled** and Enabled.

Bootup NumLock State

Use this feature to set the power on state for the <Num Lock> key. The options are **On** and Off.

Wait For "F1" If Error

Select Enabled to force the system to wait until the <F1> key is pressed if an error occurs. The options are Disabled and **Enabled**.

Re-try Boot

If this feature is set to Enabled, the system BIOS will automatically reboot the system from an Extensible Firmware Interface (EFI) boot device after an initial boot failure. The options are **Disabled** and Enabled.

Power Configuration**Watch Dog Function**

Select Enabled to allow the Watchdog timer to reboot the system when it is inactive for more than five minutes. The options are **Disabled** and Enabled.

Restore on AC Power Loss

Use this feature to set the power state after a power outage. Select Stay Off for the system power to remain off after a power loss. Select Power On for the system power to be turned on after a power loss. Select Last State to allow the system to resume its last power state before a power loss. The options are Stay Off, Power On, and **Last State**.

Power Button Function

This feature controls how the system shuts down when the power button is pressed. Select 4 Seconds Override to power off the system after pressing and holding the power button for four seconds or longer. Select Instant Off to instantly power off the system as soon as you press the power button. The options are **Instant Off** and 4 Seconds Override.

DeepSx Power Policies

Use this feature to configure the Advanced Configuration and Power Interface (ACPI) settings for the system. Enable S4 to use Hibernation mode (Suspend to Disk) so that all data stored in the main memory can be saved in a non-volatile memory area such as in a hard drive and then power down the system. Enable S5 to power off the whole system except the power supply unit (PSU) and keep the power button alive so that you can wake up the system by using a USB keyboard or mouse. The options are **Disabled**, Enabled In S4-S5, and Enabled in S5.

Delay Time Before PCI Enumeration

Use this feature to set the amount of time the system waits before enumerating PCI devices during the boot process. The valid range is 0–30 with a step of 1 second. The default setting is **0** for off, meaning the system will skip the delay time and immediately begin enumerating PCI devices.

CPU Configuration Menu

► CPU Configuration

Important: Setting the wrong values in this section may cause the system to malfunction.

The following processor information is displayed.

- Processor BSP Revision
- CPU Signature
- Microcode Patch
- Max CPU Speed
- Min CPU Speed
- CPU Speed
- Number of Performance-core(s)
- Number of Efficient-core(s)
- VMX
- SMX/TXT
- 64-bit
- EIST Technology
- CPU C3 state
- CPU C6 state
- CPU C7 state
- CPU C8 state
- CPU C9 state
- CPU C10 state
- Performance L1 Data Cache
- Performance L1 Instruction Cache
- Performance L2 Cache
- Performance L3 Cache
- Efficient L1 Data Cache

- Efficient L1 Instruction Cache
- Efficient L2 Cache
- Efficient L3 Cache

Intel Virtualization Technology

Select Enabled to enable the Intel Vanderpool Technology for Virtualization platform support, which allows multiple operating systems to run simultaneously on the same computer to maximize system resources for performance enhancement. The options are Disabled and **Enabled**. Changes take effect after you save settings and reboot the system.

Notes:

- This feature is NOT available when "TXT Support" is set to Enabled.
- This feature is NOT available when "Workload Profile" is set to Virtualization.

Active Performance-cores

This feature determines how many performance cores will be activated for each processor package. When all is selected, all cores in the processor will be activated. The options are **All**, 7, 6, 5, 4, 3, 2, and 1.

Active Efficient-cores

This feature determines how many efficient cores will be activated for each processor package. When all is selected, all cores in the processor will be activated. The options are **All**, 11, 10, 9, 8, 7, 6, 5, 4, 3, 2, and 1.

AES

Select Enabled to use the Intel Advanced Encryption Standard (AES) to ensure data security. The options are Disabled and **Enabled**.

Boot Performance Mode

This feature allows you to select the performance state that the BIOS will set before the operating system handoff. The options are **Max Non-Turbo Performance** and Turbo Performance.

Intel® SpeedStep™

Intel SpeedStep Technology allows the system to automatically adjust processor voltage and core frequency to reduce power consumption and heat dissipation. The options are Disabled and **Enabled**.

Intel® Speed Shift Technology

Use this feature to enable or disable Intel Speed Shift Technology support. When this feature is enabled, the Collaborative Processor Performance Control (CPPC) version 2 interface will be available to control CPU P-States. The options are Disabled and **Enabled**.

Turbo Mode

Select Enabled to allow the CPU to operate at the manufacturer-defined turbo speed by increasing CPU clock frequency. This feature is available when it is supported by the processors used in the system. The options are Disabled and **Enabled**.

Notes:

- This feature is available when "SpeedStep (P-States)" is set to Enabled.
- This feature is available when "Workload Profile" is set to Disabled.

Power Limit 1 Override

Select Enabled to support average power limit (PL1) override. The options are **Disabled** and Enabled.

Power Limit 2 Override

Select Enabled to support rapid power limit (PL2) override. The options are Disabled and **Enabled**.

Power Limit 2

Use this feature to configure the value for Power Limit 2. The value is in milliwatts and the step size is 125 mW. Use the number keys on your keyboard to enter the value. Enter 0 to use the manufacture default setting. If the value is 0, the BIOS will set PL2 as 1.25* TDP.

C-States

Use this feature to enable the C-State of the CPU. The options are Disabled and **Enabled**.

Enhanced C-States

Use this feature to enable the enhanced C-State of the CPU. The options are Disabled and **Enabled**.

C-State Auto Demotion

Use this feature to prevent unnecessary excursions into the C-states to improve latency. The options are Disabled and **C1**.

C-State Un-Demotion

This feature allows you to enable or disable the un-demotion of C-State. The options are Disabled and **C1**.

Package C-State Demotion

Use this feature to enable or disable the Package C-State demotion. The options are Disabled and **Enabled**.

Package C-State Un-Demotion

Use this feature to enable or disable the Package C-State un-demotion. The options are Disabled and **Enabled**.

C-State Pre-Wake

This feature allows you to enable or disable the C-State Pre-Wake. The options are Disabled and **Enabled**.

Package C-State Limit

Use this feature to set the Package C-State limit. The options are C0/C1, C2, C3, C6, C7, C7s, C8, C9, C10, Cpu Default, and **Auto**.

Monitor MWAIT

Select Enabled to support MONITOR and MWAIT, which are two instructions in Streaming SIMD Extension 3 (SSE3) to improve synchronization between multiple threads for CPU performance enhancement. The options are Disabled and **Enabled**.

Chipset Configuration Menu

► Chipset Configuration

Important: Setting the wrong values in this section may cause the system to malfunction.

System Agent (SA) Configuration

VT-d Supported

VT-d

Select Enabled to activate Intel Virtualization Technology support for Direct I/O VT-d by reporting the I/O device assignments to VMM through the DMAR ACPI Tables. This feature offers fully-protected I/O resource-sharing across the Intel platforms, providing the user with greater reliability, security and availability in networking and data-sharing. The options are **Enabled** and Disabled.

X2APIC Enable

Use this feature to enable or disable the Advanced Programmable Interrupt Controller (X2APIC) operating mode. The options are Disabled and **Enabled**.

DMA Control Guarantee

Use this feature to enable or disable DMA Control Guarantee bit. The options are **Enabled** and Disabled.

Memory Configuration Menu

▶ **Memory Configuration**

This submenu is used to configure the Integrated Memory Controller (IMC) settings.

- Memory RC Version
- Memory Frequency
- Memory Timings (tCL-tRCD-tRP-tRAS)
- DIMMA1
- DIMMA2
- DIMMB1
- DIMMB2

Maximum Memory Frequency

Use this feature to set the maximum memory frequency for onboard memory modules. The options are **Auto**, 1600, 2400, 3200, 3600, 4000, 4200, 4400, 4600, 4800, 5000, 5200, 5400, 5600, 5800, 6000, 6200, and 6400.

Max TOLUD

This feature sets the maximum TOLUD value, which specifies the "Top of Low Usable DRAM" memory space to be used by internal graphics devices, GTT Stolen Memory, and TSEG, respectively, if these devices are enabled. The options are **Dynamic**, 1 GB, 1.25 GB, 1.5 GB, 1.75 GB, 2 GB, 2.25 GB, 2.5 GB, 2.75 GB, 3 GB, 3.25 GB, and 3.5 GB.

Memory Scrambler

Use this feature to enable or disable memory scrambler support. The options are Disabled and **Enabled**.

Force ColdReset

Use this feature to enable or disable a cold boot during a MRC execution. The options are Enabled and **Disabled**.

Force Single Rank

Select enabled to use only Rank 0 in each DIMM. The options are **Disabled** and Enabled.

Memory Remap

Use this feature to enable or disable memory remap above 4 GB. The options are **Enabled** and Disabled.

MRC Fast Boot

Use this feature to enable or disable fast path through the memory reference code. The options are Disabled and **Enabled**.

Total Memory Encryption

Use this feature to enable or disable Total Memory Encryption (TME). When enabled, Intel TME enhances memory data security. The options are **Disabled** and Enabled.

Graphics Configuration Menu

► Graphics Configuration

This submenu allows you to configure the graphics configuration settings.

Graphics Configuration

IGFX GOP Version

Skip Scanning of External Gfx Card

If this feature is enabled, the system will not scan for an external graphics card on PEG and PCIe slots. The options are **Disabled** and Enabled.

Primary Display

Use this feature to select the primary video display. The options are Auto and **IGFX**.

Internal Graphics

Select Auto to keep an internal graphics device installed on an expansion slot supported by the CPU to be automatically enabled. The options are Auto, Disabled, and **Enabled**.

DVMT Pre-Allocated

Dynamic Video Memory Technology (DVMT) allows dynamic allocation of system memory to be used for video devices to ensure best use of available system memory based on the DVMT 5.0 platform. The options are 0M, 32M, 64M, 96M, **128M**, 4M, 8M, 12M, 16M, 20M, 24M, 28M, 32M/F7, 36M, 40M, 44M, 48M, 52M, 56M, and 60M.

Configure GT for use

Use this feature to enable or disable GT configuration. The options are Disabled and **Enabled**.

PAVP Enable

Use this feature to enable or disable PAVP support. The options are Disabled and **Enabled**.

DMI Configuration Menu

▶ **DMI Configuration**

This submenu allows you to configure the DMI configuration settings.

DMI ASPM

Use this feature to set the Active State Power Management (ASPM) state on the System Agent (SA) side of the DMI Link. The options are Disabled, ASPM L1, and **Auto**.

PEG Port Configuration

▶ **PEG Port Configuration**

CPU SLOT7 PCIe 5.0 x16

Enable Root Port

Use this feature to enable or disable the PCIe Graphics (PEG) device in the specified port . The options are Disabled and **Enabled**.

Max Link Speed

Use this feature to select PCIe support for the device installed the M.2 specified port. The options are **Auto**, Gen1, Gen2, Gen3, Gen4, and Gen5.

M.2-C PCIe 5.0 x4

Enable Root Port

Use this feature to enable or disable the PCIe Graphics (PEG) device in the specified port . The options are Disabled and **Enabled**.

Max Link Speed

Use this feature to select PCIe support for the device installed the M.2 specified port. The options are **Auto**, Gen1, Gen2, Gen3, Gen4, and Gen5.

GT - Power Management Control

GT - Power Management Control

RC6 (Render Standby)

Use this feature to enable render standby support. The options are Disabled and **Enabled**.

Maximum GT Frequency

Use this feature to define the Maximum GT frequency. Choose between 1650 MHz (RPN) and 6000 MHz (RP0). Any value beyond this range will be clipped to its min/max supported by the

CPU. The options are **Default Max Frequency**, 100Mhz, 150Mhz, 200Mhz, 250Mhz, 300Mhz, 350Mhz, 400Mhz, 450Mhz, 500Mhz, 550Mhz, 600Mhz, 650Mhz, 700Mhz, 750Mhz, 800Mhz, 850Mhz, 900Mhz, 950Mhz, 100Mhz, 1050Mhz, 1100Mhz, 1150Mhz, and 1200Mhz.

Disable Turbo GT Frequency

Use this feature to disable Turbo GT frequency. If set to Enabled, Turbo GT frequency becomes disabled. If set to Disabled, GT frequency limiters will be removed. The options are Enabled and **Disabled**.

PCH-IO Configuration

PCH SKU

Stepping

PCI Express Configuration

PCI Express Configuration

Onboard LAN1

ASPM

Use this feature to activate the Active State Power Management (ASPM) level for a PCIe device. Select Auto for the system BIOS to automatically set the ASPM level based on the system configuration. Select Disabled to disable ASPM support. The options are Disabled, **L1**, and Auto.

L1 Substates

Use this feature to set the PCI Express L1 Substate. The options are Disabled, L1.1 and **L1.1 & L1.2**.

PCIe Speed

Use this feature to set the PCI Express port speed. The options are **Auto**, Gen1, Gen2, Gen3, and Gen4.

Peer Memory Write Enable

Use this feature to enable or disable Peer Memory Write. The options are **Disabled** and Enabled.

Onboard LAN2

ASPM

Use this feature to activate the Active State Power Management (ASPM) level for a PCIe device. Select Auto for the system BIOS to automatically set the ASPM level based on the system configuration. Select Disabled to disable ASPM support. The options are Disabled, **L1**,

and Auto.

L1 Substates

Use this feature to set the PCI Express L1 Substate. The options are Disabled, L1.1 and **L1.1 & L1.2**.

PCIe Speed

Use this feature to set the PCI Express port speed. The options are **Auto**, Gen1, Gen2, Gen3, and Gen4.

Peer Memory Write Enable

Use this feature to enable or disable Peer Memory Write. The options are **Disabled** and Enabled.

MCIO-1

ASPM

Use this feature to activate the Active State Power Management (ASPM) level for a PCIe device. Select Auto for the system BIOS to automatically set the ASPM level based on the system configuration. Select Disabled to disable ASPM support. The options are Disabled, **L1**, and Auto.

L1 Substates

Use this feature to set the PCI Express L1 Substate. The options are Disabled, L1.1 and **L1.1 & L1.2**.

PCIe Speed

Use this feature to set the PCI Express port speed. The options are **Auto**, Gen1, Gen2, Gen3, and Gen4.

Peer Memory Write Enable

Use this feature to enable or disable Peer Memory Write. The options are **Disabled** and Enabled.

MCIO-2

ASPM

Use this feature to activate the Active State Power Management (ASPM) level for a PCIe device. Select Auto for the system BIOS to automatically set the ASPM level based on the system configuration. Select Disabled to disable ASPM support. The options are Disabled, **L1**, and Auto.

L1 Substates

Use this feature to set the PCI Express L1 Substate. The options are Disabled, L1.1 and **L1.1 & L1.2**.

PCIe Speed

Use this feature to set the PCI Express port speed. The options are **Auto**, Gen1, Gen2, Gen3, and Gen4.

Peer Memory Write Enable

Use this feature to enable or disable Peer Memory Write. The options are **Disabled** and Enabled.

M.2-H

ASPM

Use this feature to activate the Active State Power Management (ASPM) level for a PCIe device. Select Auto for the system BIOS to automatically set the ASPM level based on the system configuration. Select Disabled to disable ASPM support. The options are Disabled, **L1**, and Auto.

L1 Substates

Use this feature to set the PCI Express L1 Substate. The options are Disabled, L1.1 and **L1.1 & L1.2**.

PCIe Speed

Use this feature to set the PCI Express port speed. The options are **Auto**, Gen1, Gen2, Gen3, and Gen4.

Peer Memory Write Enable

Use this feature to enable or disable Peer Memory Write. The options are **Disabled** and Enabled.

HTTP Boot Configuration Menu

► HTTP Boot Configuration

HTTP Boot Policy

Use this feature to set the HTTP boot policy. The options are Apply to all LANs, **Apply to each LAN**, and Boot Priority #1 instantly.

HTTPS Boot Checks Hostname

Important: Disabling "HTTPS Boot Checks Hostname" is a violation of RFC 6125 and may expose you to Man-in-the-Middle Attacks. Supermicro is not responsible for any and all security risks incurred by you disabling this feature.

Enable this feature for HTTPS boot to check the hostname of the TLS certificates to see if it matches the host name provided by the remote server. The options are **Enabled** and Disabled (WARNING: Security Risk!!).

Priority of HTTP Boot

Instance of Priority 1: (Available when your motherboard supports this feature)

This feature sets the rank target port. The default setting is **1**.

Select IPv4 or IPv6

This feature specifies which connection the target LAN port should boot from. The options are **IPv4** and IPv6.

Boot Description

Use this feature to enter a boot description, which cannot be longer than 75 characters. Be sure to enter a boot description; otherwise, the boot option for the URI cannot be created.

Boot URI

Enter a Boot Uniform Research Identifier (URI) with 128 characters or shorter. This Boot URI determines how IPv4 Boot Option and IPv6 Boot Option will be created.

Instance of Priority 2: (Available when your motherboard supports this feature)

This feature sets the rank target port. The default setting is **0**.

Instance of Priority 3: (Available when "HTTP Boot Policy" is set to Apply to each LAN or Boot Priority #1 instantly)

This feature sets the rank target port. The default setting is **0**.

Super IO Configuration Menu

► Super IO Configuration

The following information is displayed.

- Super IO Chip

Note: This submenu is available when your system supports this feature.

Serial Port 1 Configuration Menu

► Serial Port 1 Configuration

Serial Port 1

Select Enabled to enable serial port 1. The options are Disabled and **Enabled**.

Device Settings (Available when "Serial Port 1" above is set to Enabled)

This feature displays the base I/O port address and the Interrupt Request address of serial port 1.

Change Settings (Available when "Serial Port 1" above is set to Enabled)

Use this feature to specify the base I/O port address and the Interrupt Request address of serial port 1. Select Auto for the BIOS to automatically assign the base I/O and IRQ address to serial port 1. The options are **Auto**, (IO=3F8h; IRQ=4;), (IO=2F8h; IRQ=4;), (IO=3E8h; IRQ=4;), and (IO=2E8h; IRQ=4;).

Serial Port 2 Configuration Menu

► Serial Port 2 Configuration

Serial Port 2

Select Enabled to enable serial port 2. The options are Disabled and **Enabled**.

Device Settings (Available when "Serial Port 2" above is set to Enabled)

This feature displays the base I/O port address and the Interrupt Request address of serial port 2.

Change Settings (Available when "Serial Port 2" above is set to Enabled)

Use this feature to specify the base I/O port address and the Interrupt Request address of serial port 2 (or SOL). Select Auto for the BIOS to automatically assign the base I/O and IRQ address to serial port 2 (or SOL). The options are **Auto**, (IO=2F8h; IRQ=3;), (IO=3F8h; IRQ=3;), (IO=3E8h; IRQ=3;), and (IO=2E8h; IRQ=3;).

Network Stack Configuration Menu

► Network Stack Configuration

Network Stack

Select Enabled to enable Preboot Execution Environment (PXE) or Unified Extensible Firmware Interface (UEFI) for network stack support. The options are Disabled and **Enabled**.

IPv4 PXE Support (Available when "Network Stack" is set to Enabled)

Select Enabled to enable IPv4 PXE boot support. If this feature is disabled, it will not create the IPv4 PXE boot option. The options are Disabled and **Enabled**.

IPv4 HTTP Support (Available when "Network Stack" is set to Enabled)

Select Enabled to enable IPv4 HTTP boot support. If this feature is disabled, it will not create the IPv4 HTTP boot option. The options are **Disabled** and Enabled.

IPv6 PXE Support (Available when "Network Stack" is set to Enabled)

Select Enabled to enable IPv6 PXE boot support. If this feature is disabled, it will not create the IPv6 PXE boot option. The options are Disabled and **Enabled**.

IPv6 HTTP Support (Available when "Network Stack" is set to Enabled)

Select Enabled to enable IPv6 HTTP boot support. If this feature is disabled, it will not create the IPv6 HTTP boot option. The options are **Disabled** and Enabled.

PXE Boot Wait Time (Available when "Network Stack" is set to Enabled)

Use this feature to set the wait time (in seconds) upon which the system BIOS will wait for you to press the <ESC> key to abort PXE boot instead of proceeding with PXE boot by connecting to a network server immediately. Press the <+> or <-> key on your keyboard to change the value. The default setting is **0**.

Media Detect Count (Available when "Network Stack" is set to Enabled)

Use this feature to set the wait time (in seconds) for the BIOS ROM to detect the presence of a LAN media either via the Internet connection or via a LAN port. Press the <+> or <-> key on your keyboard to change the value. The default setting is **1**.

MAC:(MAC address)-IPv4 Network Configuration Menu**▶ MAC:(MAC address)-IPv4 Network Configuration****Configured**

Enable this feature to configure network addresses for DHCP, local IP address, local netmask, local gateway, and local DNS server. The options are **Disabled** and Enabled.

Enable DHCP (Available when "Configured" is set to Enabled)

Select Enabled to support Dynamic Host Configuration Protocol (DHCP), which allows the BIOS to search for a DHCP server attached to the network and request the next available IP address for this computer. The options are **Disabled** and Enabled.

Local IP Address (Available when "Configured" is set to Enabled and "Enable DHCP" is set to Disabled)

Use this feature to enter an IP address for the local machine.

Local NetMask (Available when "Configured" is set to Enabled and "Enable DHCP" is set to Disabled)

Use this feature to set the netmask for the local machine.

Local Gateway (Available when "Configured" is set to Enabled and "Enable DHCP" is set to Disabled)

Use this feature to set the gateway address for the local machine.

Local DNS Servers (Available when "Configured" is set to Enabled and "Enable DHCP" is set to Disabled)

Use this feature to set the Domain Name System (DNS) server address for the local machine.

Save Changes and Exit

Press <Enter> to save changes and exit.

MAC:(MAC address)-IPv6 Network Configuration Menu**▶ MAC:(MAC address)-IPv6 Network Configuration****▶ Enter Configuration Menu**

The following information is displayed.

- Interface Name
- Interface Type
- MAC address
- Host address
- Route Table
- Gateway addresses
- DNS addresses

Interface ID

Use this feature to change/enter the 64-bit alternative interface ID for the device. The string format is colon separated. The default setting is the MAC address above.

DAD Transmit Count

Use this feature to set the number of consecutive neighbor solicitation messages that have been sent while performing duplicate address detection on a tentative address. The default setting is **1**.

Policy

Use this feature to select how the policy is to be configured. The options are **automatic** and manual.

► Advanced Configuration

Note: This submenu is available when "Policy" is set to manual.

New IPv6 address: Use this feature to enter the IPv6 address for the local machine.

New Gateway addresses: Use this feature to set the gateway address for the local machine.

New DNS addresses: Use this feature to set the DNS server address for the local machine.

Commit Changes and Exit: Press <Enter> to save changes and exit.

Discard Changes and Exit: Press <Enter> to discard changes and exit.

Save Changes and Exit

Press <Enter> to save changes and exit.

MAC:(MAC address)-IPv4 Network Configuration Menu

► MAC:(MAC address)-IPv4 Network Configuration

Configured

Enable this feature to configure network addresses for DHCP, local IP address, local netmask, local gateway, and local DNS server. The options are **Disabled** and Enabled.

Enable DHCP (Available when "Configured" is set to Enabled)

Select Enabled to support Dynamic Host Configuration Protocol (DHCP), which allows the BIOS to search for a DHCP server attached to the network and request the next available IP address for this computer. The options are **Disabled** and Enabled.

Local IP Address (Available when "Configured" is set to Enabled and "Enable DHCP" is set to Disabled)

Use this feature to enter an IP address for the local machine.

Local NetMask (Available when "Configured" is set to Enabled and "Enable DHCP" is set to Disabled)

Use this feature to set the netmask for the local machine.

Local Gateway (Available when "Configured" is set to Enabled and "Enable DHCP" is set to Disabled)

Use this feature to set the gateway address for the local machine.

Local DNS Servers (Available when "Configured" is set to Enabled and "Enable DHCP" is set to Disabled)

Use this feature to set the Domain Name System (DNS) server address for the local machine.

Save Changes and Exit

Press <Enter> to save changes and exit.

MAC:(MAC address)-IPv6 Network Configuration Menu**▶ MAC:(MAC address)-IPv6 Network Configuration****▶ Enter Configuration Menu**

The following information is displayed.

- Interface Name
- Interface Type
- MAC address
- Host address
- Route Table
- Gateway addresses
- DNS addresses

Interface ID

Use this feature to change/enter the 64-bit alternative interface ID for the device. The string format is colon separated. The default setting is the MAC address above.

DAD Transmit Count

Use this feature to set the number of consecutive neighbor solicitation messages that have been sent while performing duplicate address detection on a tentative address. The default setting is **1**.

Policy

Use this feature to select how the policy is to be configured. The options are **automatic** and **manual**.

▶ Advanced Configuration

Note: This submenu is available when "Policy" is set to manual.

New IPv6 address: Use this feature to enter the IPv6 address for the local machine.

New Gateway addresses: Use this feature to set the gateway address for the local machine.

New DNS addresses: Use this feature to set the DNS server address for the local machine.

Commit Changes and Exit: Press <Enter> to save changes and exit.

Discard Changes and Exit: Press <Enter> to discard changes and exit.

Save Changes and Exit

Press <Enter> to save changes and exit.

MAC:(MAC address)-IPv4 Network Configuration Menu

► MAC:(MAC address)-IPv4 Network Configuration

Configured

Enable this feature to configure network addresses for DHCP, local IP address, local netmask, local gateway, and local DNS server. The options are **Disabled** and **Enabled**.

Enable DHCP (Available when "Configured" is set to Enabled)

Select **Enabled** to support Dynamic Host Configuration Protocol (DHCP), which allows the BIOS to search for a DHCP server attached to the network and request the next available IP address for this computer. The options are **Disabled** and **Enabled**.

Local IP Address (Available when "Configured" is set to Enabled and "Enable DHCP" is set to Disabled)

Use this feature to enter an IP address for the local machine.

Local NetMask (Available when "Configured" is set to Enabled and "Enable DHCP" is set to Disabled)

Use this feature to set the netmask for the local machine.

Local Gateway (Available when "Configured" is set to Enabled and "Enable DHCP" is set to Disabled)

Use this feature to set the gateway address for the local machine.

Local DNS Servers (Available when "Configured" is set to Enabled and "Enable DHCP" is set to Disabled)

Use this feature to set the Domain Name System (DNS) server address for the local machine.

Save Changes and Exit

Press <Enter> to save changes and exit.

MAC:(MAC address)-IPv6 Network Configuration Menu

▶ MAC:(MAC address)-IPv6 Network Configuration

▶ Enter Configuration Menu

The following information is displayed.

- Interface Name
- Interface Type
- MAC address
- Host address
- Route Table
- Gateway addresses
- DNS addresses

Interface ID

Use this feature to change/enter the 64-bit alternative interface ID for the device. The string format is colon separated. The default setting is the MAC address above.

DAD Transmit Count

Use this feature to set the number of consecutive neighbor solicitation messages that have been sent while performing duplicate address detection on a tentative address. The default setting is **1**.

Policy

Use this feature to select how the policy is to be configured. The options are **automatic** and manual.

▶ Advanced Configuration

Note: This submenu is available when "Policy" is set to manual.

New IPv6 address: Use this feature to enter the IPv6 address for the local machine.

New Gateway addresses: Use this feature to set the gateway address for the local machine.

New DNS addresses: Use this feature to set the DNS server address for the local machine.

Commit Changes and Exit: Press <Enter> to save changes and exit.

Discard Changes and Exit: Press <Enter> to discard changes and exit.

Save Changes and Exit

Press <Enter> to save changes and exit.

MAC:(MAC address)-IPv4 Network Configuration Menu

► MAC:(MAC address)-IPv4 Network Configuration

Configured

Enable this feature to configure network addresses for DHCP, local IP address, local netmask, local gateway, and local DNS server. The options are **Disabled** and **Enabled**.

Enable DHCP (Available when "Configured" is set to Enabled)

Select **Enabled** to support Dynamic Host Configuration Protocol (DHCP), which allows the BIOS to search for a DHCP server attached to the network and request the next available IP address for this computer. The options are **Disabled** and **Enabled**.

Local IP Address (Available when "Configured" is set to Enabled and "Enable DHCP" is set to Disabled)

Use this feature to enter an IP address for the local machine.

Local NetMask (Available when "Configured" is set to Enabled and "Enable DHCP" is set to Disabled)

Use this feature to set the netmask for the local machine.

Local Gateway (Available when "Configured" is set to Enabled and "Enable DHCP" is set to Disabled)

Use this feature to set the gateway address for the local machine.

Local DNS Servers (Available when "Configured" is set to Enabled and "Enable DHCP" is set to Disabled)

Use this feature to set the Domain Name System (DNS) server address for the local machine.

Save Changes and Exit

Press <Enter> to save changes and exit.

MAC:(MAC address)-IPv6 Network Configuration Menu

► MAC:(MAC address)-IPv6 Network Configuration

► Enter Configuration Menu

The following information is displayed.

- Interface Name
- Interface Type
- MAC address
- Host address
- Route Table
- Gateway addresses
- DNS addresses

Interface ID

Use this feature to change/enter the 64-bit alternative interface ID for the device. The string format is colon separated. The default setting is the MAC address above.

DAD Transmit Count

Use this feature to set the number of consecutive neighbor solicitation messages that have been sent while performing duplicate address detection on a tentative address. The default setting is **1**.

Policy

Use this feature to select how the policy is to be configured. The options are **automatic** and **manual**.

► Advanced Configuration

Note: This submenu is available when "Policy" is set to manual.

New IPv6 address: Use this feature to enter the IPv6 address for the local machine.

New Gateway addresses: Use this feature to set the gateway address for the local machine.

New DNS addresses: Use this feature to set the DNS server address for the local machine.

Commit Changes and Exit: Press <Enter> to save changes and exit.

Discard Changes and Exit: Press <Enter> to discard changes and exit.

Save Changes and Exit

Press <Enter> to save changes and exit.

PCH-FW Configuration

ME Firmware Version: 19.0.0.1797

ME Firmware Mode: Normal Mode

ME Firmware SKU: Corporate SKU

ME FW Image Re-Flash

Use this feature to update the Management Engine firmware. The options are **Disabled** and Enabled.

TPM Device Selection

Use this feature to select dTPM or PTT for the TPM device. dTPM is discrete Trusted Platform Module and PTT is Platform Trusted Technology. The options are **dTPM** and PTT.

AMT Configuration

USB Provisioning of AMT

Use this feature to enable or disable USB provisioning. The options are **Disabled** and Enabled.

MAC Pass Through

Use this feature to enable or disable the MAC Pass Through function. The options are **Disabled** and Enabled.

Activate Remote Assistance Process

Use this feature to activate Remote Assistance. Enabling this feature will also trigger the Client Initiated Remote Access (CIRA) boot. The options are **Disabled** and Enabled.

Unconfigure ME

Use this feature to unconfigure ME with resetting the MEBx password to default on next boot. The options are **Disabled** and Enabled.

ASF Configuration

PET Progress

Use this feature to enable or disable PET Events Progress to receive PET Events alerts. The options are Disabled and **Enabled**.

WatchDog

Select Enabled to allow the Watchdog timer to reboot the system when it is inactive for more than five minutes. The options are **Disabled** and Enabled.

OS Timer / BIOS Timer

These options appear if WatchDog (above) is enabled. This is a timed delay in seconds, before a system power down or reset after a BIOS or operating system failure is detected. Enter the value in seconds. The default setting is **0**.

ASF Sensors Table

Enable this feature for the ASF Sensor Table to be added into the ASF ACPI table. The options are **Disabled** and Enabled.

Secure Erase Configuration

Secure Erase mode

Select Real to securely erase a solid state drive. The options are **Simulated** and Real.

Force Secure Erase

Select Enabled to force a secure erase of the solid state drive on the next boot. The options are **Disabled** and Enabled.

One Click Recovery (OCR) Configuration

OCR Https Boot

Use this feature to enable or disable One Click Recovery Https Boot. One Click Recovery is a recovery process that lets you restore your computer to its last known good state with a single command. The options are Disabled and **Enabled**.

OCR PBA Boot

Use this feature to enable or disable One Click Recovery PBA Boot. The options are Disabled and **Enabled**.

OCR Windows Recovery Boot

Use this feature to enable or disable One Click Recovery Windows Boot. The options are Disabled and **Enabled**.

OCR Disable Secure Boot

Use this feature to allow CSME to request Secure Boot to be disabled for One Click Recovery. The options are Disabled and **Enabled**.

PCIe/PCI/PnP Configuration Menu

PCI PERR/SERR Support

Use this feature to enable or disable the runtime event for PCI errors. The options are **Disabled** and **Enabled**.

Re-Size BAR Support

Use this feature to enable Resizable Base Address Register (BAR) support. Resizable BAR is a PCIe interface technology that allows the CPU to access the entire frame buffer. With this technology, your system will be able to handle multiple CPU to GPU transfers simultaneously rather than queuing, which can improve the frame rate performance. The options are **Disabled** and **Enabled**.

SR-IOV Support (Unavailable when "Workload Profile" is set to Virtualization)

Select **Enabled** for Single-Root IO Virtualization support. The options are **Disabled** and **Enabled**.

BME DMA Mitigation

Enable this feature to help block DMA attacks. The options are **Disabled** and **Enabled**.

Onboard Video Option ROM

Select **EFI** to boot the system using the Extensible Firmware Interface (EFI) device installed on the onboard video port. The options are **Disabled** and **EFI**.

NVMe Firmware Source

Use this feature to select the NVMe firmware to support system boot. The options are **Vendor Defined Firmware** and **AMI Native Support**. The option of Vendor Defined Firmware is pre-installed on the drive and may resolve errata or enable innovative functions for the drive. The default option, AMI Native Support, is offered by the BIOS with a generic method.

Consistent Device Name Support

This feature controls the device naming for network devices and slots. The options are **Disabled** and **Enabled**.

PCIe/PCI/PnP Configuration

M.2-C PCIe 5.0 x4 OPROM

Use this feature to select which firmware type to be loaded for the add-on card in this slot. The options are **Disabled** and **EFI**.

CPU SLOT7 PCIe 5.0 x16 OPROM

Use this feature to select which firmware type to be loaded for the add-on card in this slot. The options are **Disabled** and **EFI**.

MCIO-1 OPROM

Use this feature to select which firmware type to be loaded for the add-on card in this slot. The options are Disabled and **EFI**.

MCIO-2 OPROM

Use this feature to select which firmware type to be loaded for the add-on card in this slot. The options are Disabled and **EFI**.

M.2-H OPROM

Use this feature to select which firmware type to be loaded for the add-on card in this slot. The options are Disabled and **EFI**.

Onboard LAN1 Support

Use this feature to enable or disable LAN1. The options are Disabled and **Enabled**.

Onboard LAN2 Support

Use this feature to enable or disable LAN2. The options are Disabled and **Enabled**.

Onboard LAN1 Option ROM

Select EFI to boot the system using the EFI device installed on LAN port 1. The options are Disabled and **EFI**.

Note: This feature is available when your motherboard supports onboard LAN ports.

SATA and RST Configuration

SATA And RST Configuration**SATA Controller(s)**

Use this feature to enable or disable the onboard SATA controller supported by the Intel PCH chip. The options are **Enabled** and Disabled.

Support Aggressive Link Power Management

When this feature is set to Enabled, the SATA AHCI controller manages the power usage of the SATA link. The controller will put the link in a low power mode during extended periods of I/O inactivity and will return the link to an active state when I/O activity resumes. The options are Disabled and **Enabled**.

I-SATA5 / I-SATA6 / I-SATA7

This feature displays the information detected on the installed SATA drive on the particular SATA port.

Software Preserve Support

Hot Plug

Set this feature to Enable for hot plug support, which allows you to replace a SATA drive without shutting down the system. The options are Disabled and **Enabled**.

Spin Up Device

Set this feature to enable or disable the PCH to initialize the device. The options are **Disabled** and Enabled.

SATA Device Type

Use this feature to specify if the SATA port is connected to a Solid State Drive or a Hard Disk Drive. The options are **Hard Disk Drive** and Solid State Drive.

VMD Setup Menu

► VMD Setup Menu

VMD Configuration

Enable VMD Controller

Use this feature to enable or disable the VMD controller. The options are **Disabled** and Enabled.

Enable VMD Global Mapping (Available when Enable VMD Controller is set to "Enabled")

Use this feature to enable or disable VMD global mapping. The options are **Disabled** and Enabled.

Map PCH SATA Controller under VMD (Available when Enable VMD Controller is set to "Enabled")

Use this feature to map or unmap the selected root port to VMD. The options are **Disabled** and Enabled.

Serial Port Console Redirection Menu

► Serial Port Console Redirection

COM1

Console Redirection

Select Enabled to enable COM port 1 for Console Redirection, which allows a client machine to be connected to a host machine at a remote site for networking. The options are **Disabled** and Enabled.

Note: This feature will be set to Enabled if there is no BMC support.

SOL

Note: This feature is available when your system supports serial port of SOL.

Console Redirection

Select Enabled to use the SOL port for Console Redirection. The options are Disabled and Enabled.

AMT SOL

COM3 Console Redirection

Select Enabled to enable console redirection support for the specified serial port. The options are **Disabled** and Enabled.

► Console Redirection Settings

Note: This submenu is available when "Console Redirection" for COM1, SOL/COM2, or AMT SOL is set to Enabled.

Terminal Type

Use this feature to select the target terminal emulation type for Console Redirection. Select VT100 to use the ASCII character set. Select VT100+ to add color and function key support. Select ANSI to use the extended ASCII character set. Select VT-UTF8 to use UTF8 encoding to map Unicode characters into one or more bytes. The options are VT100, **VT100+**, VT-UTF8, and ANSI.

Bits Per Second

Use this feature to set the transmission speed for a serial port used in Console Redirection. Make sure that the same speed is used in the host computer and the client computer. A lower transmission speed may be required for long and busy lines. The options are 9600, 19200, 38400, 57600, and **115200** (bits per second).

Data Bits

Use this feature to set the data transmission size for Console Redirection. The options are 7 and **8** (bits).

Parity

A parity bit can be sent along with regular data bits to detect data transmission errors. Select Even if the parity bit is set to 0 and the number of 1s in data bits is even. Select Odd if the parity bit is set to 0 and the number of 1s in data bits is odd. Select None if you do not want to

send a parity bit with your data bits in transmission. Select **Mark** to add a mark as a parity bit to be sent along with the data bits. Select **Space** to add a space as a parity bit to be sent with your data bits. The options are **None**, Even, Odd, Mark, and Space.

Stop Bits

A stop bit indicates the end of a serial data packet. Select 1 (stop bit) for standard serial data communication. Select 2 (stop bits) if slower devices are used. The options are **1** and **2**.

Flow Control

Use this feature to set the flow control for Console Redirection to prevent data loss caused by buffer overflow. Send a "Stop" signal to stop sending data when the receiving buffer is full. Send a "Start" signal to start sending data when the receiving buffer is empty. The options are **None** and Hardware RTS/CTS.

VT-UTF8 Combo Key Support

Select Enabled to enable VT-UTF8 Combination Key support for ANSI/VT100 terminals. The options are Disabled and **Enabled**.

Recorder Mode

Select Enabled to capture the data displayed on a terminal and send it as text messages to a remote server. The options are **Disabled** and Enabled.

Resolution 100x31

Select Enabled for extended-terminal resolution support. The options are Disabled and **Enabled**.

Putty KeyPad

Use this feature to select the function key and keypad settings on Putty, which is a terminal emulator designed for the Windows OS. The options are **VT100**, LINUX, XTERMR6, SCO, ESCN, and VT400.

Redirection After BIOS POST

Use this feature to enable or disable legacy console redirection after BIOS POST. When set to Bootloader, legacy console redirection is disabled before booting the OS. When set to Always Enable, legacy console redirection remains enabled when booting the OS. The options are **Always Enable** and Bootloader.

Serial Port for Out-of-Band Management/Windows Emergency Management Services (EMS)

Use the features below to configure Console Redirection settings to support Out-of-Band Serial Port management.

Console Redirection EMS

Select Enabled to use the SOL port for Console Redirection. The options are **Disabled** and Enabled.

► Console Redirection Settings

Note: This submenu is available when "Console Redirection EMS" is set to Enabled.

Out-of-Band Mgmt Port

Use this feature to select a serial port in a client server to be used by the Microsoft Windows Emergency Management Services (EMS) to communicate with a remote host server. The options are **COM1** and SOL/COM2. Note that the option of SOL/COM2 indicates a shared serial port. SOL is available with BMC support.

Terminal Type EMS

Use this feature to select the target terminal emulation type for Console Redirection. Select VT100 to use the ASCII character set. Select VT100+ to add color and function key support. Select ANSI to use the extended ASCII character set. Select VT-UTF8 to use UTF8 encoding to map Unicode characters into one or more bytes. The options are VT100, VT100+, **VT-UTF8**, and ANSI.

Bits Per Second EMS

This feature sets the transmission speed for a serial port used in Console Redirection. Make sure that the same speed is used in the host computer and the client computer. A lower transmission speed may be required for long and busy lines. The options are 9600, 19200, 57600, and **115200** (bits per second).

Flow Control EMS

Use this feature to set the flow control for Console Redirection to prevent data loss caused by buffer overflow. Send a "Stop" signal to stop sending data when the receiving buffer is full. Send a "Start" signal to start sending data when the receiving buffer is empty. The options are **None**, Hardware RTS/CTS, and Software Xon/Xoff.

The following information is displayed.

- **Data Bits EMS**
- **Parity EMS**
- **Stop Bits EMS**

Trusted Computing Menu

► Trusted Computing

When the TPM 2.0 (either onboard or external) is detected by your system, the following information is displayed.

- TPM 2.0 Device Found
- Firmware Version:
- Vendor:

Note: This submenu is available when the TPM 2.0 (either onboard or external) is detected by the BIOS.

Security Device Support

Select Enabled to enable BIOS support for onboard security devices, which are not displayed in the OS. If this feature is set to Enabled, TCG EFI protocol and INT1A interface will not be available. The options are Disabled and **Enabled**.

When "Security Device Support" is set to Enabled and the TPM 2.0 (either onboard or external) is detected by the BIOS, the following information is displayed.

- Active PCR banks
- Available PCR banks

Note: The following features are available when the TPM 2.0 (either onboard or external) is detected by the BIOS.

SHA256 PCR Bank (Available when "Security Device Support" is set to Enabled)

Select Enabled to enable SHA256 PCR Bank support to enhance system integrity and data security. The options are Disabled and **Enabled**.

SHA384 PCR Bank (Available when "Security Device Support" is set to Enabled)

Select Enabled to enable SHA384 PCR Bank support to enhance system integrity and data security. The options are **Disabled** and Enabled.

Pending Operation (Available when "Security Device Support" is set to Enabled)

Use this feature to schedule a TPM-related operation to be performed by the security TPM (either onboard or external) at the next system boot to enhance system data integrity. The options are **None** and TPM Clear.

Note: If this feature is used, your system will reboot to carry out a pending TPM operation.

Platform Hierarchy (Available when "Security Device Support" is set to Enabled)

Select Enabled for TPM Platform Hierarchy support, which allows the manufacturer to utilize the cryptographic algorithm to define a constant key or a fixed set of keys to be used for initial system boot. These early boot codes are shipped with the platform and are included in the list of "public keys." During system boot, the platform firmware uses the trusted public keys to verify a digital signature in an attempt to manage and control the security of the platform firmware used in a host system via the TPM (either onboard or external). The options are Disabled and **Enabled**.

Storage Hierarchy (Available when "Security Device Support" is set to Enabled)

Select Enabled for TPM Storage Hierarchy support that is intended to be used for non-privacy-sensitive operations by a platform owner such as an IT professional or the end user. Storage Hierarchy has an owner policy and an authorization value, both of which can be set and are held constant (-rarely changed) through reboots. This hierarchy can be cleared or changed independently of the other hierarchies. The options are Disabled and **Enabled**.

TPM 2.0 InterfaceType

This feature displays the TPM interface type. The default option is **TIS**.

Endorsement Hierarchy (Available when "Security Device Support" is set to Enabled)

Select Enabled for Endorsement Hierarchy support, which contains separate controls to address the user's privacy concerns because the primary keys in the hierarchy are certified by the TPM key or by a manufacturer with restrictions on how an authentic TPM (either onboard or external) that is attached to an authentic platform can be accessed and used. A primary key can be encrypted and certified with a certificate created by using TPM2_ActivateCredential, which allows the user to independently enable "flag, policy, and authorization values" without involving other hierarchies. A user with privacy concerns can disable the endorsement hierarchy while still using the storage hierarchy for TPM applications, permitting the platform software to use the TPM. The options are Disabled and **Enabled**.

PH Randomization

Select Enabled for Platform Hierarchy (PH) Randomization support, which is used only during the platform developmental stage. This feature cannot be enabled in the production platforms. The options are **Disabled** and Enabled.

Intel Trusted Execution Technology

Intel Trusted Execution Technology (TXT) helps protect against software-based attacks and ensures protection, confidentiality, and integrity of data stored or created on the system. Use this feature to enable or disable TXT Support. The options are **Disabled** and Enabled.

USB Configuration Menu

► USB Configuration

USB Module Version

USB Controllers

USB Devices

XHCI Hand-off

This is a work-around solution for operating systems that do not support Extensible Host Controller Interface (XHCI) hand-off. The XHCI ownership change should be claimed by the XHCI driver. The settings are **Enabled** and Disabled.

USB Mass Storage Driver Support

Select Enabled for USB mass storage device support. The options are Disabled and **Enabled**.

USB S5 Wakeup Support

Use this feature to enable or disable USB S5 Wakeup support. The options are Disabled and **Enabled**.

Intel Ethernet Controller I226-LM

UEFI Driver

Device Name

Link Status

MAC Address

Intel Ethernet Controller I226-LM

UEFI Driver

Device Name

Link Status

MAC Address

Intel Ethernet Controller X550

Blink LEDs

Use this feature to identify the physical network port by blinking the associated LED. The default setting is **0** (up to 15 seconds).

UEFI Driver

Adapter PBA

Device Name

Chip Type

PCI Device ID

PCI Address

Link Status

MAC Address

Virtual MAC Address

Firmware Image Properties

The following firmware image information is displayed.

- Option ROM version
- Unique NVM/EEPROM ID
- NVM Version

NIC Configuration

Link Speed

The feature displays the connection speed of a LAN port. The options are **Auto Negotiated**, 10 Mbps Half, 10 Mbps Full, 100 Mbps Half, and 100 Mbps Full.

Wake On LAN

If this feature is set to Enabled, the LAN port you specified will be enabled when the system is powered on. The options are Disabled and **Enabled**.

Intel Ethernet Controller X550

Blink LEDs

Use this feature to identify the physical network port by blinking the associated LED. The default setting is **0** (up to 15 seconds).

UEFI Driver

Adapter PBA

Device Name

Chip Type

PCI Device ID

PCI Address

Link Status

MAC Address

Virtual MAC Address

Firmware Image Properties

The following firmware image information is displayed.

- Option ROM version
- Unique NVM/EEPROM ID
- NVM Version

NIC Configuration

Link Speed

The feature displays the connection speed of a LAN port. The options are **Auto Negotiated**, 10 Mbps Half, 10 Mbps Full, 100 Mbps Half, and 100 Mbps Full.

Wake On LAN

If this feature is set to Enabled, the LAN port you specified will be enabled when the system is powered on. The options are Disabled and **Enabled**.

TLS Authenticate Configuration Menu

► TLS Authenticate Configuration

Use this submenu to configure Transport Layer Security (TLS) settings.

► Server CA Configuration

Use this feature to configure the server Certificate Authority (CA).

► Enroll Certification

Use this feature to enroll the certificates in the system.

► Enroll Certification Using File

Use this feature to enroll the security certificates in the system by using a file.

▶ **Commit Changes and Exit**

Use this feature to save all changes and exit TLS settings.

▶ **Discard Changes and Exit**

Use this feature to discard all changes and exit TLS settings.

▶ **Delete Certification**

Use this feature to delete the certificates that have been enrolled in the system.

▶ **Client Certification Configuration**

This feature is to manage the certificates used to authenticate remote clients connecting to your system. Add, view, or delete client certificates as needed.

Driver Health Menu

▶ **Driver Health**

This feature displays the health information of the drivers installed in your system, including LAN controllers, as detected by the BIOS. Select one and press <Enter> to see the details.

Note: This section is provided for reference only. The driver health status will differ depending on the drivers installed in your system. It's also based on your system configuration and the environment that your system is operating in.

4.4 Event Logs

Use this menu to configure Event Logs settings.

Note: After making any changes in this section, be sure to reboot the system for the changes to take effect.



Figure 4-3. Event Logs Screen

▶ Change SMBIOS Event Log Settings

Note: Reboot the system for the changes in this section to take effect.

Enabling/Disabling Options

SMBIOS Event Log

Select Enabled to enable System Management BIOS (SMBIOS) Event Logging during system boot. The options are Disabled and **Enabled**.

Erasing Settings

Erase Event Log (Available when "SMBIOS Event Log" is set to Enabled)

Select No to keep the event log without erasing it upon next system bootup. Select (Yes, Next reset) to erase the event log upon next system reboot. The options are **No**, (Yes, Next reset), and (Yes, Every reset).

When Log is Full (Available when "SMBIOS Event Log" is set to Enabled)

Select Erase Immediately to immediately erase all errors in the SMBIOS event log when the event log is full. Select Do Nothing for the system to do nothing when the SMBIOS event log is full. The options are **Do Nothing** and Erase Immediately.

SMBIOS Event Log Standard Settings

Log System Boot Event (Available when "SMBIOS Event Log" is set to Enabled)

Select Enabled to log system boot events. The options are Enabled and **Disabled**.

MECI (Available when "SMBIOS Event Log" is set to Enabled)

Enter the increment value for the multiple event counter. Enter a number between 1 and 255. The default setting is **1**. (MECI is the abbreviation for Multiple Event Count Increment.)

METW (Available when "SMBIOS Event Log" is set to Enabled)

Use this feature to determine how long (in minutes) should the multiple event counter wait before generating a new event log. Enter a number between 0 and 99. The default value is **60**. (METW is the abbreviation for Multiple Event Count Time Window.)

► View SMBIOS Event Log

Use this feature to view the events in the system event log. Select this feature and press <Enter> to view the status of an event in the log. The following information is displayed: DATE / TIME / ERROR CODE / SEVERITY.

4.5 BMC

Use this menu to configure Baseboard Management Console (BMC) settings.

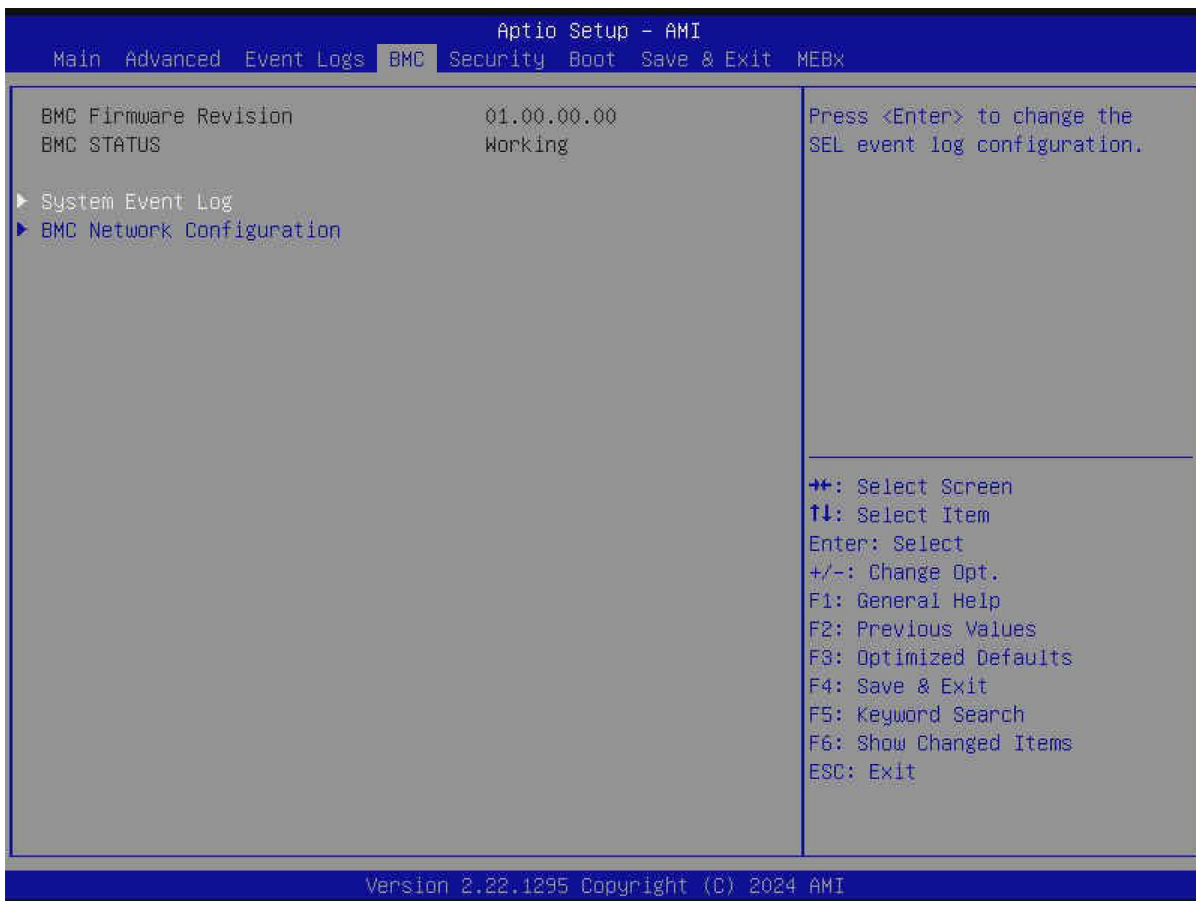

Figure 4-4. BMC Screen

BMC Firmware Revision

This feature indicates the BMC firmware revision used in this system.

BMC STATUS

This feature indicates the status of the BMC firmware installed in this system.

System Event Log Menu

► System Event Log

Note: All values changed in this submenu do not take effect until next system reboot.

Enabling/Disabling Options

SEL Components

Select Enabled to enable all system event logging upon system boot. The options are Disabled and **Enabled**.

Erasing Settings

Erase SEL (Available when "SEL Components" is set to Enabled)

Select (Yes, On next reset) to erase all system event logs upon next system boot. Select (Yes, On every reset) to erase all system event logs upon each system reboot. Select No to keep all system event logs after each system reboot. The options are **No**, (Yes, On next reset), and (Yes, On every reset).

When SEL is Full (Available when "SEL Components" is set to Enabled)

This feature defines what the BIOS should do when the system event log is full. Select Erase Immediately to erase all events in the log when the system event log is full. The options are **Do Nothing** and Erase Immediately.

BMC Network Configuration Menu

► BMC Network Configuration

Update BMC LAN Configuration

Select Yes for the BIOS to implement all IP/MAC address changes upon next system boot. The options are **No** and Yes.

Configure IPv4 Support

BMC LAN Selection

This feature displays the type of the BMC LAN.

BMC Network Link Status:

This feature displays the status of the BMC network link for this system.

Configuration Address Source

Use this feature to select the source of the IPv4 connection. If Static is selected, note the IP address of the IPv4 connection and enter it to the system manually in the field. If DHCP is selected, the BIOS will search for a Dynamic Host Configuration Protocol (DHCP) server in the

network that is attached to and request the next available IP address for this computer. The options are Static and **DHCP**. It is available for configuration when "Update BMC LAN Configuration" is set to Yes.

Station IP Address

This feature displays the Station IP address in decimal and in dotted quad form (i.e., 172.29.176.131). It is available for configuration when "Update BMC LAN Configuration" is set to Yes and "Configuration Address Source" above is set to Static.

Subnet Mask

This feature displays the sub-network that the system belongs to. It is available for configuration when "Update BMC LAN Configuration" is set to Yes and "Configuration Address Source" above is set to Static.

Station MAC Address

This feature displays the Station MAC address for the system. MAC addresses are six two-digit hexadecimal numbers.

Gateway IP Address

This feature displays the IPv4 gateway IP address for the system. This should be in decimal and in dotted quad form (i.e., 172.29.0.1). It is available for configuration when "Update BMC LAN Configuration" is set to Yes and "Configuration Address Source" above is set to Static.

Configure IPv6 Support

IPv6 Address Status

This feature displays the status of the IPv6 address.

IPv6 Support

Use this feature to enable IPv6 support. The options are **Enabled** and Disabled. It is available for configuration when "Update BMC LAN Configuration" is set to Yes.

Configuration Address Source

Use this feature to select the source of the IPv6 connection. If Static Configuration is selected, note the IP address of IPv6 connection and enter it to the system manually in the field. If the other two options are selected, the BIOS will search for a DHCP server in the network that is attached to and request the next available IP address for this computer. The options are Static Configuration, **DHCPv6 Stateless**, and DHCPv6 Stateful. It is available for configuration when "Update BMC LAN Configuration" is set to Yes.

IPv6 Address ("Static," "DHCPv6 Stateless," or "DHCPv6 Stateful," depending on the option you selected for "Configuration Address Source" above)

This feature displays the station IPv6 address. It is available for configuration when "Update BMC LAN Configuration" is set to Yes and "Configuration Address Source" above is set to Static Configuration.

Prefix Length

This feature displays the prefix length. It is available for configuration when "Update BMC LAN Configuration" is set to Yes and "Configuration Address Source" above is set to Static Configuration.

Gateway IP

This feature displays the IPv6 gateway IP address. It is available for configuration when "Update BMC LAN Configuration" is set to Yes and "Configuration Address Source" above is set to Static Configuration.

Advanced Settings

Use this feature to set the DNS server IP. The default setting allows this system to obtain the DNS server IP automatically. The options are **Auto obtain DNS server IP** and **Manually obtain DNS server IP**. It is available for configuration when "Update BMC LAN Configuration" is set to Yes and "Configuration Address Source" above is set to DHCPv6 Stateless.

Preferred DNS server IP (Available when "Advanced Settings" above is set to Manually obtain DNS server IP)

This feature displays the preferred DNS server IP. It can be configured via Redfish.

Alternative DNS server IP (Available when "Advanced Settings" above is set to Manually obtain DNS server IP)

This feature displays the alternative DNS server IP. It can be configured via Redfish.

Configure VLAN Support

VLAN Support

Use this feature to enable the virtual LAN (VLAN) support. The options are **Enabled** and **Disabled**.

VLAN ID (Available when "VLAN Support" is set to Enabled)

Use this feature to create a new VLAN ID. The valid range is 1–4094. The default setting is **1**.

4.6 Security

Use this menu to configure the following security settings for the system.

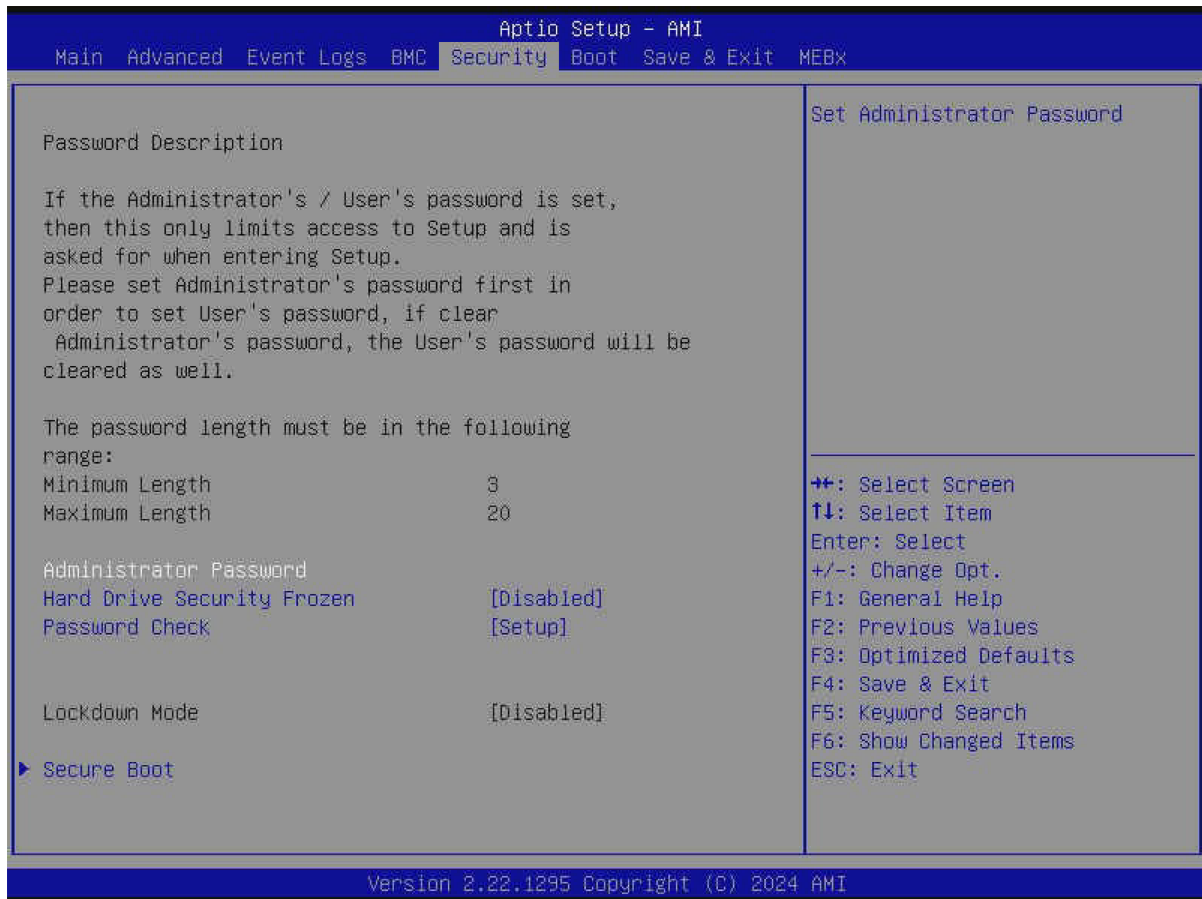

Figure 4-5. Security Screen

Administrator Password

This feature indicates if an administrator password has been installed. Use this feature to set the administrator password, which is required to enter the BIOS Setup utility. The length of the password can be between three and 20 characters long.

User Password (Available when "Administrator Password" has been set)

This feature indicates if a user password has been installed. Use this feature to set the user password which is required to enter the BIOS Setup utility. The length of the password can be between three and 20 characters long.

Hard Drive Security Frozen

Select Enabled to freeze the Lock Security feature for HDD to protect key data in hard drives from being altered. The options are **Disabled** and Enabled.

Password Check

Select Setup for the system to check for a password upon entering the BIOS Setup utility. Select Always for the system to check for the passwords needed at bootup and upon entering the BIOS Setup utility. The options are **Setup** and Always.

Lockdown Mode (Available when the DCMS key is activated)

Select Enabled to support the Lockdown Mode, which prevents the existing data or keys stored in the system from being altered or changed in an effort to preserve system integrity and security. The options are **Disabled** and Enabled.

Secure Boot Menu

► Secure Boot

The following information is displayed:

- System Mode
- Secure Boot

Note: For detailed instructions on configuring Security Boot settings, refer to the Security Boot Configuration User's Guide at <https://www.supermicro.com/support/manuals>.

Secure Boot

Select Enabled to configure Secure Boot settings. The options are **Disabled** and Enabled.

Secure Boot Mode

Use this feature to select the desired secure boot mode for the system. The options are Standard and **Custom**.

► Enter Audit Mode

Select Ok to enter the Audit Mode workflow. It will result in erasing the Platform Key (PK) variables and resetting the system to the Setup/Audit Mode.

Note: This submenu is available when "Secure Boot Mode" is set to Custom.

► Enter Deployed Mode / Exit Deployed Mode

Select Ok to reset system to the User Mode or to the Deployed Mode.

Note: This submenu is available when "Secure Boot Mode" is set to Custom.

► Key Management

The following information is displayed:

- Vendor Keys

Note: This submenu is available when "Secure Boot Mode" is set to Custom.

Provision Factory Defaults

Select Enabled to install the default secure boot keys when the system is in the Setup Mode. Changes take effect after you save settings and reboot the system. The options are **Disabled** and Enabled.

► Restore Factory Keys

Select Yes to restore manufacturer default keys to ensure system security. The options are **Yes** and No. Selecting Yes will reset the system to the User Mode.

Note: This submenu is available when any secure keys have been installed.

► Reset To Setup Mode

This feature resets the system to the Setup Mode. The options are **Yes** and No.

Note: This submenu is available when any secure keys have been installed.

► Enroll Efi Image

This feature allows the Efi image to run in the secure boot mode and enroll the SHA256 Hash certificate of a PE image into the Authorized Signature Database (DB).

► Export Secure Boot Variables

This feature exports the NVRAM contents of secure boot variables to a storage device. The options are **Yes** and No.

Note: This submenu is available when any secure keys have been installed.

Secure Boot variable / Size / Keys / Key Source

▶ Platform Key (PK)

Use this feature to enter and configure a set of values to be used as platform firmware keys for the system. These values also indicate the sizes, key numbers, and the sources of the authorized signatures. Select Update to update the platform key.

▶ Key Exchange Keys (KEK)

Use this feature to enter and configure a set of values to be used as Key Exchange Keys for the system. These values also indicate the sizes, key numbers, and the sources of the authorized signatures. Select Update to update the Key Exchange Keys. Select Append to append the Key Exchange Keys.

▶ Authorized Signatures (db)

Use this feature to enter and configure a set of values to be used as Authorized Signatures for the system. These values also indicate the sizes, key numbers, and sources of the authorized signatures. Select Update to update the Authorized Signatures. Select Append to append the new Authorized Signatures.

▶ Forbidden Signatures (dbx)

Use this feature to enter and configure a set of values to be used as Forbidden Signatures for the system. These values also indicate sizes, key numbers, and key sources of the forbidden signatures. Select Update to update the Forbidden Signatures. Select Append to append the Forbidden Signature.

▶ Authorized TimeStamps (dbt)

Use this feature to set and save the timestamps for the Authorized Signatures, which will indicate the time when these signatures are entered into the system. These values also indicate sizes, keys, and key sources of the authorized timestamps. Select Update to update the Authorized TimeStamps. Select Append to append the Authorized TimeStamps.

▶ OsRecovery Signatures (dbr)

Use this feature to set and save the Authorized Signatures used for OS recovery. Select Update to update the OsRecovery Signatures. These values also indicate sizes, keys, and key sources of the OsRecovery Signatures. Select Append to append the OsRecovery Signatures.

4.7 Boot

Use this menu to configure Boot settings.

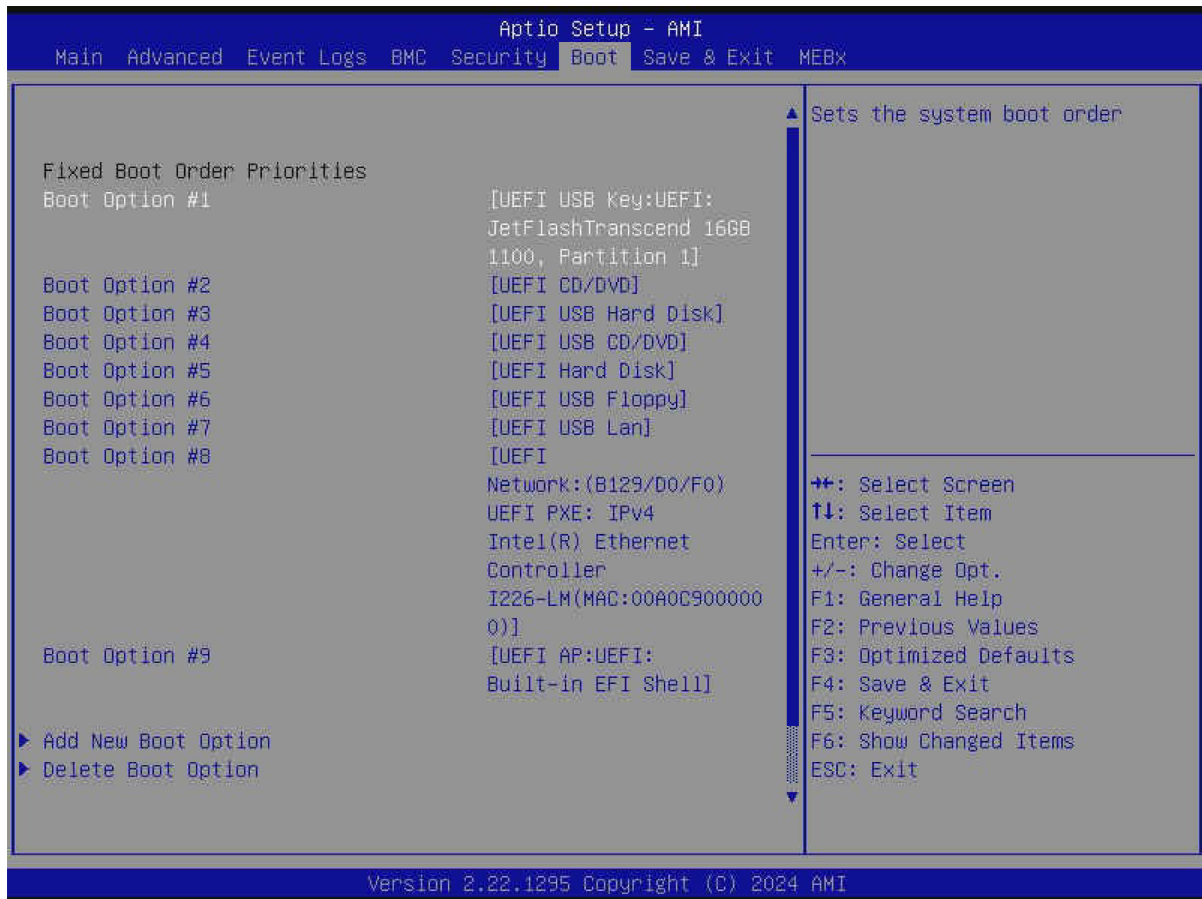

Figure 4-6. Boot Screen

FIXED BOOT ORDER Priorities

Use this feature to prioritize the order of bootable devices from which the system will boot. Press <Enter> on each item sequentially to select the device.

- Boot Option #1 – Boot Option #9

► Add New Boot Option

Use this feature to add a new boot option to the boot priority features for system boot.

Note: This submenu is available when any storage device is detected by the BIOS.

Add boot option

Use this feature to specify the name for the new boot option.

Path for boot option

Use this feature to enter the path for the new boot option in the format fsx:\path\filename.efi.

Boot option File Path

Use this feature to specify the file path for the new boot option.

Create

After setting the name and the file path for the boot option, press <Enter> to create the new boot option in the boot priority list.

▶ Delete Boot Option

Use this feature to select a boot device to delete from the boot priority list.

Delete Boot Option

Use this feature to remove an EFI boot option from the boot priority list.

▶ UEFI USB Key Drive BBS Priorities

Use this feature to set the system boot order of detected devices.

▶ UEFI NETWORK Drive BBS Priorities

Use this feature to set the system boot order of detected devices.

▶ UEFI Application Boot Priorities

Use this feature to set the system boot order of detected devices.

4.8 Save & Exit

Select Save & Exit from the BIOS Setup screen to configure the settings below.

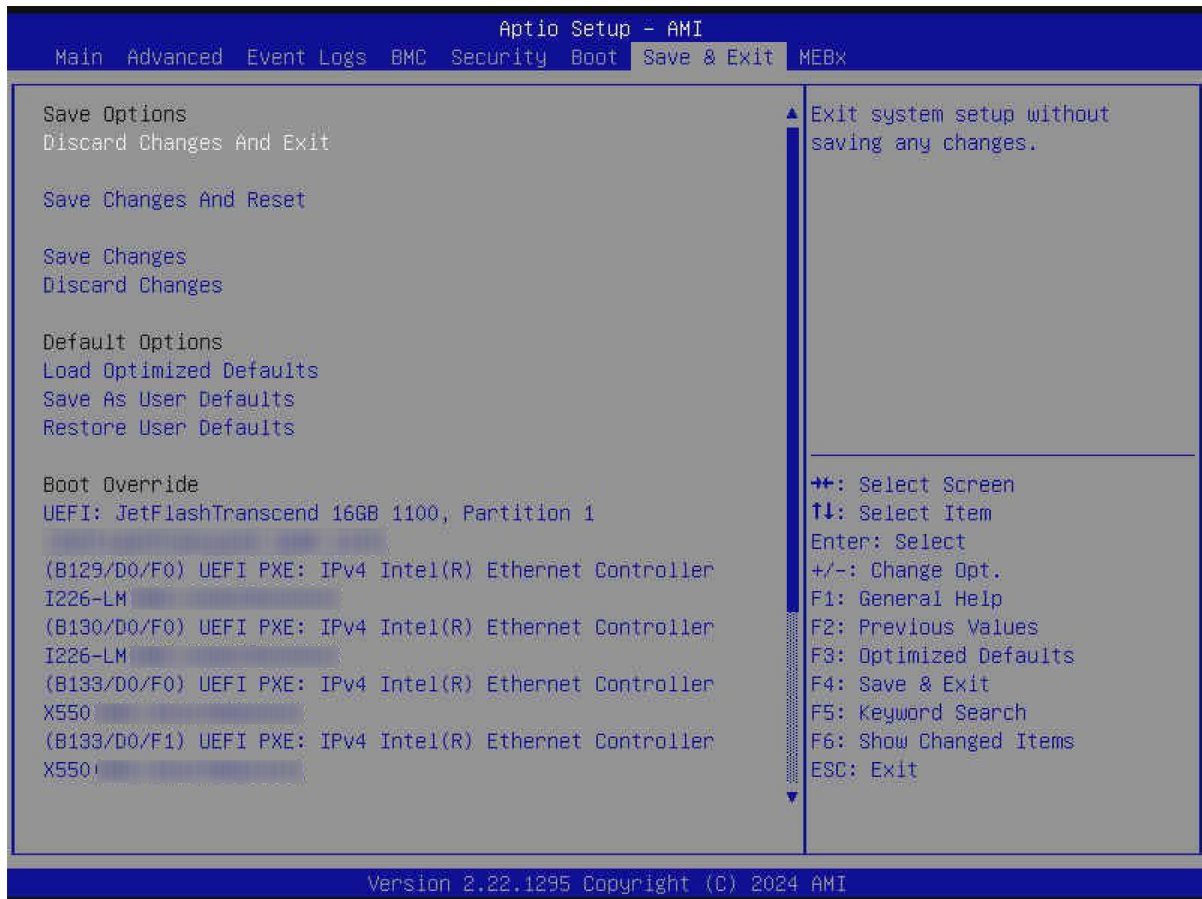

Figure 4-7. Save & Exit Screen

Save Options

Discard Changes and Exit

Use this feature to exit from the BIOS Setup utility without making any permanent changes to the system configuration and reboot the system.

Save Changes and Reset

On completing the system configuration changes, use this feature to exit the BIOS Setup utility and reboot the system for the new system configuration parameters to take effect.

Save Changes

On completing the system configuration changes, use this feature to save all changes made. This will not reset (reboot) the system.

Discard Changes

Select this feature and press <Enter> to discard all changes made and return to the BIOS Setup utility.

Default Options**Load Optimized Defaults**

Select this feature and press <Enter> to load manufacturer optimized default settings, which are intended for maximum system performance but not for maximum stability.

Note: After pressing <Enter>, reboot the system for the changes to take effect, which ensures that this system has the optimized default settings.

Save as User Defaults

Select this feature and press <Enter> to save all changes as the default values specified to the BIOS Setup utility for future use.

Restore User Defaults

Select this feature and press <Enter> to restore user-defined default settings that have been saved previously.

Boot Override

Note: Use this section to override the Boot priorities sequence in the Boot menu, and immediately boot the system with a device specified here instead of the one specified in the boot list. This is a one-time boot override.

Launch EFI Shell from filesystem device

Use this feature to launch the EFI shell application (Shell.efi) from one of the available filesystem devices. A filesystem is a virtual, logical, or physical system for organizing, managing, and accessing the files and directories on devices such as SSDs, HDDs, or other storage devices.

4.9 MEBx

Use this menu to create a password for MEBx.

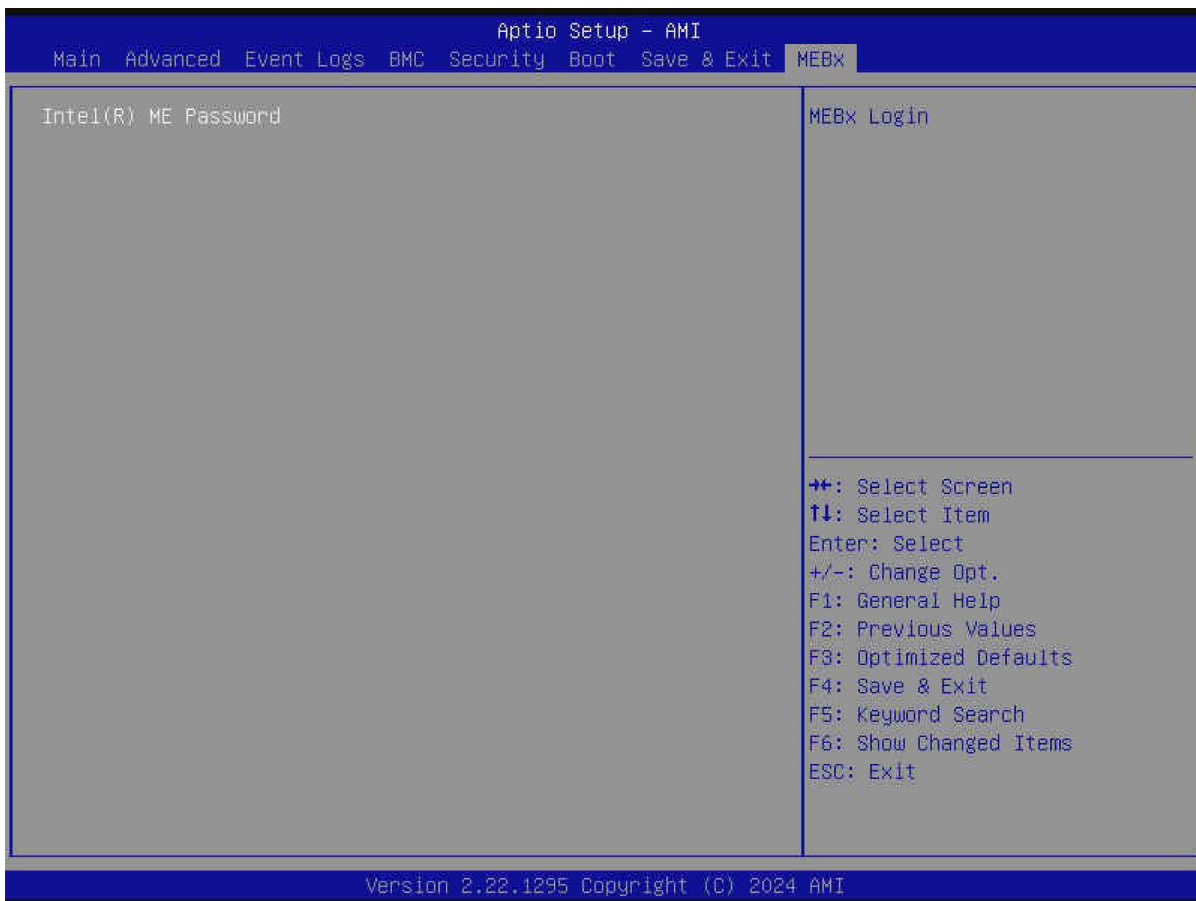

Figure 4-8. MEBx Screen

Intel(R) ME Password

Use this feature to create a password for the Intel Management Engine BIOS Extension.

Intel(R) AMT (Available after entering a password for Intel(R) ME Password)

Use this feature to enable or disable Active Management Technology (AMT). The options are Disabled, Partially Disabled, and **Enabled**.

Change ME Password (Available after entering a password for Intel(R) ME Password)

Press Enter and follow the prompt to change the password.

▶ Intel(R) AMT Configuration

▶ Redirection features

SOL

Use this feature to enable the SOL firmware interface. The options are Disabled and **Enabled**.

Storage Redirection

Use this feature to enable the firmware remote storage redirection. The options are Disabled and **Enabled**.

KVM Feature Selection

Use this feature to enable the firmware KVM feature. The options are Disabled and **Enabled**.

▶ User Consent

User Opt-in

Use this feature to configure when user consent is required. The options are None, **KVM**, and ALL.

Opt-in Configurable from Remote IT

Use this feature to enable or disable the remote change capability of the User Opt-in feature. The options are Disabled and **Enabled**.

Password Policy

Use this feature to set the password policy. The options are Default Password Only, During Setup And Configuration, and **Anytime**.

▶ Network Setup

▶ Intel(R) ME Network Name Settings

FQDN

Use this feature to specify the fully qualified domain name.

Shared/Dedicated FQDN

Use this feature to select dedicated or shared for the fully qualified domain name. The options are Dedicated and **Shared**.

▶ TCP/IP Settings

▶ Wired LAN IPv4 Configuration

DHCP Mode

Use this feature to enable or disable IPv4 DHCP mode. The options are Disable and **Enabled**.

Network Access State

Use this feature to change the state of the network state of ME. The options are Network Active, **Network Inactive**, Partial Unprovision, and Full Unprovision.

► Remote Setup And Configuration

Provisioning Server address

Use this feature to enter the provisioning server address. It's either a host name, IPv4, or IPv6.

Provisioning server port number

Use this feature to enter the provisioning server port number. The port numbers can range from 0 to 65535.

Remote Configuration **

Use this feature to enable or disable remote configuration. The options are Disabled and **Enabled**.

PKI DNS Suffix

Use this feature to enter the PKI DNS suffix.

Activate Remote Configuration

Use this feature to activate remote configuration.

► Manage Certificates

► Go Daddy Class 2 CA

This page displays information about the Go Daddy Root 2 CA certificates.

Active

Use this feature to set this certificate to active. The options are NO and **YES**.

Default

Shows this certificate as default. The option is **YES**.

Hash type

Hash data

► Go Daddy Root 2 CA-G2

This page displays information about the Go Daddy Class 2 CA-G2 certificates.

Active

Use this feature to set this certificate to active. The options are NO and **YES**.

Default

Shows this certificate as default. The option is **YES**.

Hash type

Hash data

▶ **Comodo AAA CA**

This page displays information about the Comodo AAA CA certificates.

Active

Use this feature to set this certificate to active. The options are NO and **YES**.

Default

Shows this certificate as default. The option is **YES**.

Hash type

Hash data

▶ **Starfield Class 2 CA**

This page displays information about the Starfield Class 2 CA certificates.

Active

Use this feature to set this certificate to active. The options are NO and **YES**.

Default

Shows this certificate as default. The option is **YES**.

Hash type

Hash data

▶ **Starfield Root CA-G2**

This page displays information about the Starfield Root 2 CA-G2 certificates.

Active

Use this feature to set this certificate to active. The options are NO and **YES**.

Default

Shows this certificate as default. The option is **YES**.

Hash type**Hash data****► VeriSign Class 3 Primary CA-G5**

This page displays information about the VeriSign Class 3 Primary CA-G5 certificates.

Active

Use this feature to set this certificate to active. The options are NO and **YES**.

Default

Shows this certificate as default. The option is **YES**.

Hash type**Hash data****► Baltimore CyberTrust Root**

This page displays information about the Baltimore CyberTrust Root certificates.

Active

Use this feature to set this certificate to active. The options are NO and **YES**.

Default

Shows this certificate as default. The option is **YES**.

Hash type**Hash data****► USERTrust RSA CA**

This page displays information about the USERTrust RSA CA certificates.

Active

Use this feature to set this certificate to active. The options are NO and **YES**.

Default

Shows this certificate as default. The option is **YES**.

Hash type**Hash data****► Verizon Global Root**

This page displays information about the Verizon Global Root certificates.

Active

Use this feature to set this certificate to active. The options are NO and **YES**.

Default

Shows this certificate as default. The option is **YES**.

Hash type**Hash data****▶ Entrust .net CA (2048)**

This page displays information about the Entrust .net CA (2048) certificates.

Active

Use this feature to set this certificate to active. The options are NO and **YES**.

Default

Shows this certificate as default. The option is **YES**.

Hash type**Hash data****▶ Entrust Root CA**

This page displays information about the Entrust Root CA certificates.

Active

Use this feature to set this certificate to active. The options are NO and **YES**.

Default

Shows this certificate as default. The option is **YES**.

Hash type**Hash data****▶ Entrust Root CA-G2**

This page displays information about the Entrust Root CA-G2 certificates.

Active

Use this feature to set this certificate to active. The options are NO and **YES**.

Default

Shows this certificate as default. The option is **YES**.

Hash type**Hash data****► VeriSign Universal Root CA**

This page displays information about the VeriSign Universal Root CA certificates.

Active

Use this feature to set this certificate to active. The options are NO and **YES**.

Default

Shows this certificate as default. The option is **YES**.

Hash type**Hash data****► Affirm Trust Premium**

This page displays information about the Affirm Trust Premium certificates.

Active

Use this feature to set this certificate to active. The options are NO and **YES**.

Default

Shows this certificate as default. The option is **YES**.

Hash type**Hash data****► DigiCert Global Root CA**

This page displays information about the DigiCert Global Root CA certificates.

Active

Use this feature to set this certificate to active. The options are NO and **YES**.

Default

Shows this certificate as default. The option is **YES**.

Hash type**Hash data****► DigiCert Global Root G2**

This page displays information about the DigiCert Global Root G2 certificates.

Active

Use this feature to set this certificate to active. The options are NO and **YES**.

Default

Shows this certificate as default. The option is **YES**.

Hash type**Hash data****▶ DigiCert Global Root G3**

This page displays information about the DigiCert Global Root G3 certificates.

Active

Use this feature to set this certificate to active. The options are NO and **YES**.

Default

Shows this certificate as default. The option is **YES**.

Hash type**Hash data****▶ DigiCert Trusted Root G4**

This page displays information about the DigiCert Trusted Root G4 certificates.

Active

Use this feature to set this certificate to active. The options are NO and **YES**.

Default

Shows this certificate as default. The option is **YES**.

Hash type**Hash data****▶ GlobalSign Root CA - R3**

This page displays information about the GlobalSign Root CA - R3 certificates.

Active

Use this feature to set this certificate to active. The options are NO and **YES**.

Default

Shows this certificate as default. The option is **YES**.

Hash type**Hash data****▶ GlobalSign ECC Root CA - R5**

This page displays information about the GlobalSign ECC Root CA - R5 certificates.

Active

Use this feature to set this certificate to active. The options are NO and **YES**.

Default

Shows this certificate as default. The option is **YES**.

Hash type**Hash data****▶ GlobalSign Root CA - R6**

This page displays information about the GlobalSign Root CA - R6 certificates.

Active

Use this feature to set this certificate to active. The options are NO and **YES**.

Default

Shows this certificate as default. The option is **YES**.

Hash type**Hash data****▶ Power Control****ME ON in Host Sleep States**

Use this feature to select the host sleep states. The options are Desktop: ON in S0 and **Desktop: ON in S0, ME Wake in S3, S4-5**.

Idle Timeout

Use this feature to enter the timeout value. The value can range from 1 to 65535.

Appendix A:

BIOS Codes

For information about BIOS codes for the X14SAV-TLN4F/F motherboard, refer to the following content.

BIOS Error POST (Beep) Codes

During the Power-On Self-Test (POST) routines, which are performed each time the system is powered on, errors may occur.

Non-fatal errors are those which, in most cases, allow the system to continue the boot up process. The error messages normally appear on the screen.

Fatal errors are those which will not allow the system to continue the boot up process. If a fatal error occurs, you should consult with your system manufacturer for possible repairs.

These fatal errors are usually communicated through a series of audible beeps that can be heard on an external buzzer connected to JD1. The table shown below lists some common errors and their corresponding beep codes encountered by users.

BIOS Beep (POST) Codes		
Beep Code	Error Message	Description
1 beep	Refresh	Circuits have been reset (Ready to power up)
5 short, 1 long	Memory error	No memory detected in system
5 short, 2 long	Display memory read/write error	Video adapter missing or with faulty memory
1 long continuous	System OH	System overheat condition

Additional BIOS POST Codes

The AMI BIOS supplies additional checkpoint codes, which are documented online at <https://www.supermicro.com/support/manuals> ("AMI BIOS POST Codes User's Guide").

For information on AMI updates, refer to <https://www.ami.com/products>.

Appendix B:

Software

After the X14SAV-TLN4F/F motherboard has been installed, you can install the Operating System (OS), configure RAID settings, and install the drivers.

Microsoft Windows OS Installation

If you will be using RAID, you must configure RAID settings before installing the Windows OS and the RAID driver. Refer to the RAID Configuration User Guides posted on our website at <https://www.supermicro.com/support/manuals>.

Installing the OS

1. Create a method to access the Microsoft Windows installation ISO file. That can be a USB flash or media drive, or the BMC KVM console.
2. Retrieve the proper drivers. Go to the Supermicro web page for your motherboard and click on "Download the Latest Drivers and Utilities," select the proper driver, and copy it to a USB flash drive.
3. Boot from a bootable device with Windows OS installation. You can see a bootable device list by pressing <F11> during the system bootup.

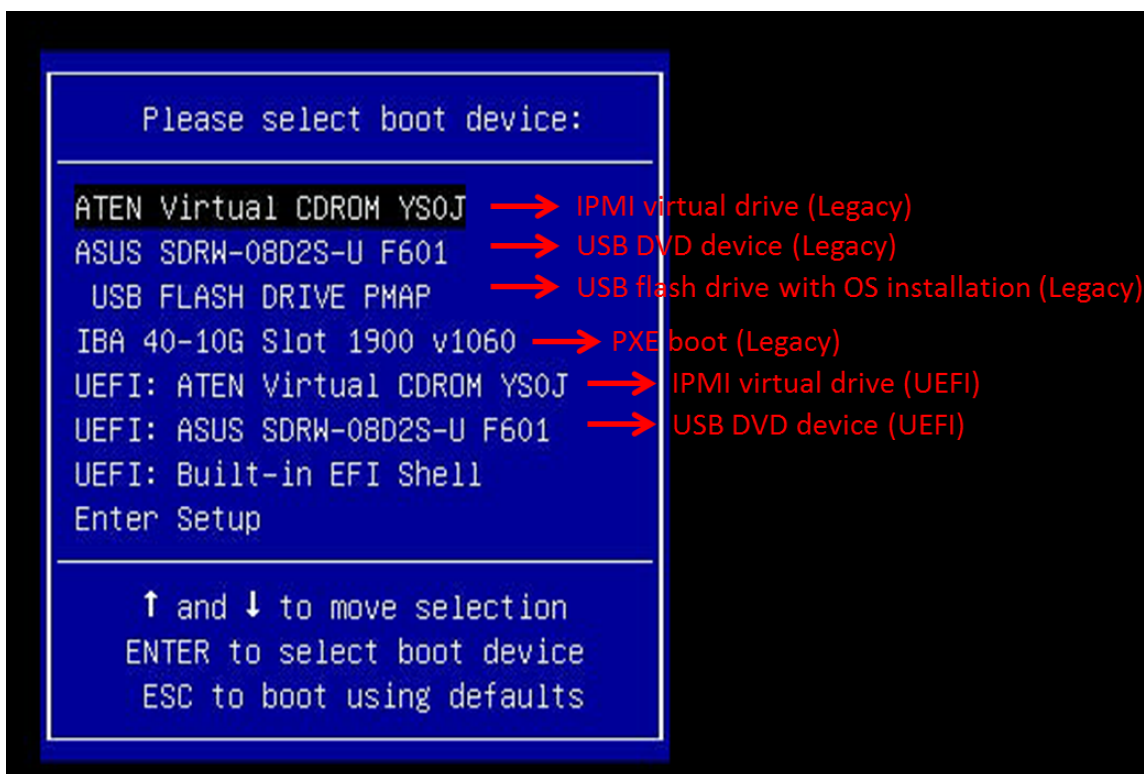

Figure B-1. Selecting the Boot Device

4. During Windows Setup, continue to the dialog box where you select the drives on which to install Windows. If the disk you want to use is not listed, click on the “Load driver” link at the bottom left corner.

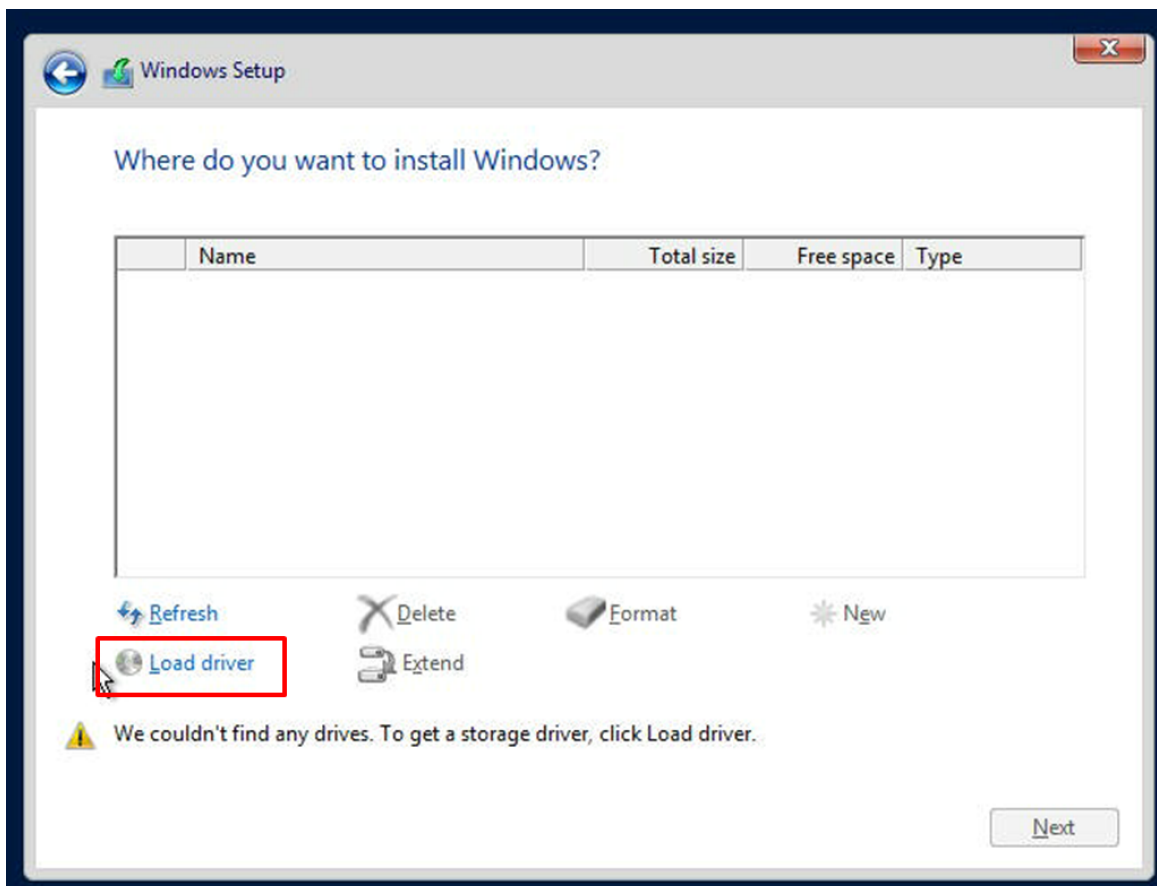

Figure B-2. Loading the Driver Link

To load the driver, browse the USB flash drive for the proper driver files.

5. Once all devices are specified, continue with the installation.
6. After the Windows OS installation has completed, the system will automatically reboot multiple times for system updates.

Driver Installation

The Supermicro website contains drivers and utilities for your system at the following page:

<https://www.supermicro.com/wdl>.

Some of these drivers and utilities must be installed, such as the chipset driver. After accessing the website, go into the CDR_Images (in the parent directory of the above link) and locate the ISO file for your motherboard. Download this file to a USB flash or media drive. You may also use a utility to extract the ISO file if preferred.

Another option is to go to the Supermicro website at <https://www.supermicro.com>. Find the product page for your motherboard and download the latest drivers and utilities. Insert the flash drive or disk, and the screenshot shown below should appear.

Note: Click the icons showing a hand writing on paper to view the readme files for each item. Click the computer icons to the right of these items to install each item (from top to bottom) one at a time. After installing each item, you must reboot the system before moving on to the next item on the list. The bottom icon with a CD on it allows you to view the entire contents.

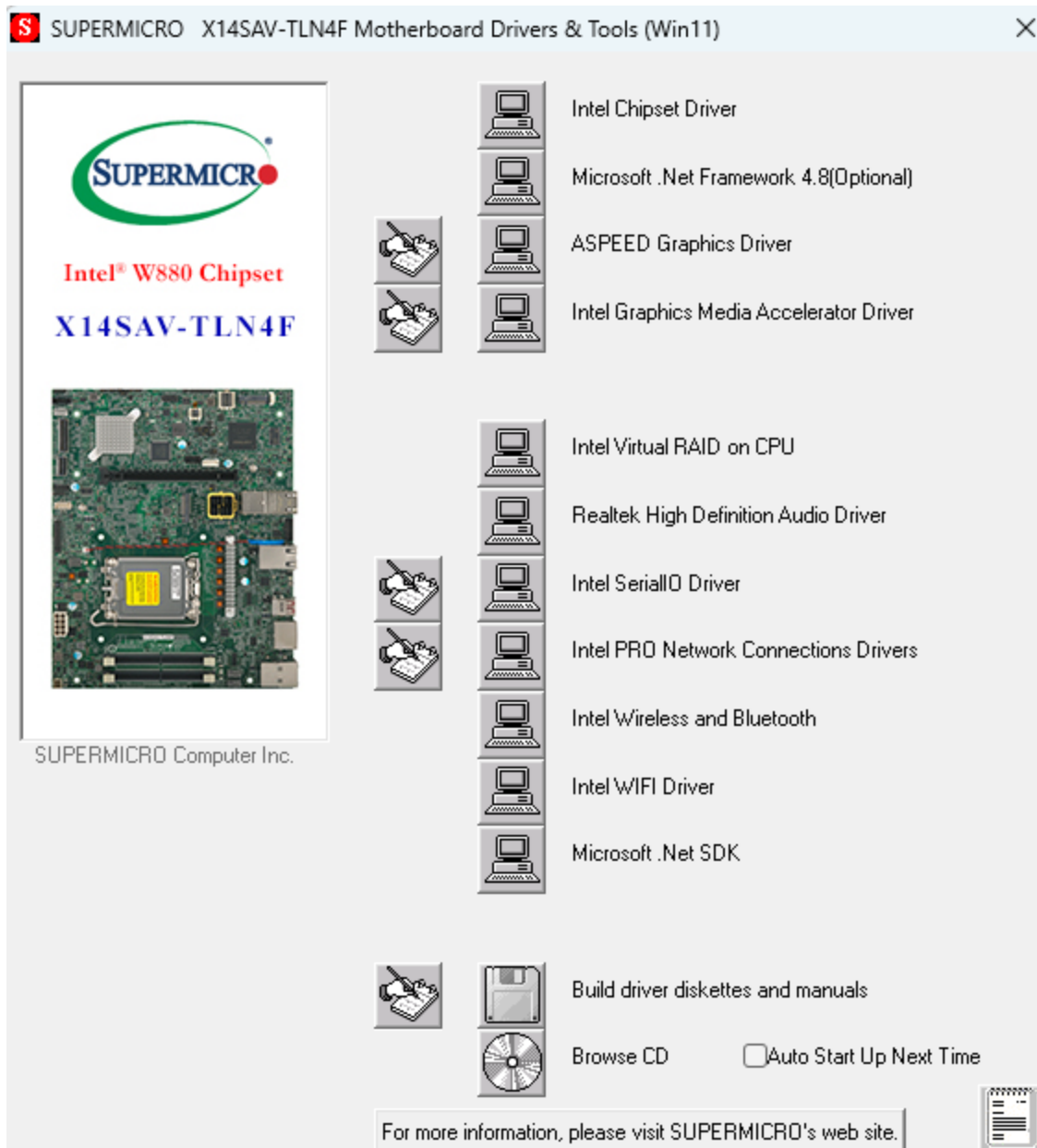

Figure B-3. Driver Installation Screenshot

BMC

The X14SAV-TLN4F/F motherboard provides remote access, monitoring, and management through the baseboard management controller (BMC) and other management controllers distributed among different system modules. There are several BIOS settings that are related to BMC. For general documentation and information on BMC, visit our website at the following page:

<https://www.supermicro.com/en/solutions/management-software/bmc-resources>

BMC ADMIN User Password

For security, each system is assigned a unique default BMC password for the ADMIN user. The password can be found on a sticker on the motherboard and a sticker on the chassis, for Supermicro chassis. The sticker also displays the BMC MAC address. If necessary, the password can be reset using the Supermicro IPMICFG tool.



Figure B-4. BMC Password Label

Appendix C:

Standardized Warning Statements

The following statements are industry standard warnings, provided to warn the user of situations which have the potential for bodily injury. Should you have questions or experience difficulty, contact Supermicro's Technical Support department for assistance. Only certified technicians should attempt to install or configure components.

Read this section in its entirety before installing or configuring components in the Supermicro X14SAV-TLN4F/F motherboard.

These warnings may also be found on our website at the following page:

https://www.supermicro.com/about/policies/safety_information.cfm

Battery Handling



Warning! There is risk of explosion if the battery is replaced by an incorrect type. Replace the battery only with the same or equivalent type recommended by the manufacturer. Dispose of used batteries according to the manufacturer's instructions.

تحذير! يوجد خطر حدوث انفجار إذا تم استبدال البطارية بنوع غير صحيح. استبدل البطارية بنفس النوع أو نوع مكافئ موصى به من قبل الشركة المصنعة فقط. يجب التخلص من البطاريات المستخدمة وفقاً لإرشادات الجهة المصنعة.

警告! 如果更换的电池类型不正确, 有爆炸危险。更换电池时, 请使用制造商推荐的相同或同等型号的电池。请按制造商的说明处理废旧电池。

警告! 如果更換的電池類型不正確, 有爆炸危險。請使用製造商建議之相同或功能相當的電池更換原有電池。請按照製造商的說明指示處理廢棄舊電池。

Advarsel! Der er risiko for eksplosion, hvis batteriet skiftes med et batteri af den forkerte type. Batteriet må kun skiftes med et batteri af samme eller tilsvarende type, der anbefales af producenten. Opbrugte batterier skal bortskaffes i henhold til vejledningerne fra producenten.

Waarschuwing! Er bestaat een explosiegevaar als de batterij wordt vervangen door een onjuist type. Vervang de batterij alleen door hetzelfde type of een soortgelijk type aanbevolen door de fabrikant. Verwijder gebruikte batterijen overeenkomstig de instructies van de fabrikant.

Varoitus! Väärän tyyppisen akun käyttö voi aiheuttaa räjähdysvaaran. Vaihda akku vain valmistajan suositteluun samaan tai vastaavaan tyyppiseen akkuun. Hävitä käytetyt paristot valmistajan ohjeiden mukaisesti.

Attention! Il y a un risque d'explosion si la batterie est remplacée par une d'un type incorrect. Remplacez la batterie uniquement par une d'un type identique ou équivalent recommandé par le fabricant. Éliminez les batteries usagées conformément aux instructions du fabricant.

Warnung! Es besteht Explosionsgefahr, wenn die Batterie durch einen falschen Typ ersetzt wird. Ersetzen Sie die Batterie ausschließlich durch denselben oder einen vom Hersteller empfohlenen gleichwertigen Typ. Entsorgen Sie gebrauchte Batterien gemäß den Anweisungen des Herstellers.

אזהרה! קיימת סכנת פיצוץ אם הסוללה תוחלף בסוללה מסוג שגוי. החלף את הסוללה רק בסוללה מאותו סוג או בסוללה מקבילה המומלצת על ידי היצרן. השלך סוללות משומשות בהתאם להוראות היצרן.

चेतावनी! यदि बैटरी को गलत प्रकार से बदला जाता है तो विस्फोट का जोखिम है। बैटरी को केवल निर्माता द्वारा अनुशंसित समान या समकक्ष प्रकार से ही बदलें। इस्तेमाल की गई बैटरियों का निपटान निर्माता के निर्देशों के अनुसार करें।

警告! 電池を間違ったタイプに交換すると爆発する危険があります。交換する電池はメーカーが推奨するタイプ、または同等のものを使用してください。使用済み電池は、メーカーの指示に従って廃棄してください。

경고! 배터리를 잘못된 종류로 교체하면 폭발의 위험이 있습니다. 기존 배터리와 동일하거나 제조사에서 권장하는 동등한 종류의 배터리로만 교체해야 합니다. 제조사의 안내에 따라 사용된 배터리를 처리하여 주십시오.

Advarsel! Det er fare for eksplosjon hvis batteriet byttes ut med et av feil type. Batterier skal kun byttes ut med et av lik eller tilsvarende type, som anbefalt av produsenten. Kast brukte batterier i henhold til produsentens instruksjoner.

¡Advertencia! Existe riesgo de explosión si se sustituye la batería por una de tipo incorrecto. Reemplace la batería únicamente con el mismo tipo o uno equivalente recomendado por el fabricante. Deseche las baterías usadas de acuerdo con las instrucciones del fabricante.

Varning! Det finns risk för explosion om batteriet byts ut mot en felaktig typ. Byt endast ut batteriet mot ett batteri av samma eller likvärdig typ som rekommenderas av tillverkaren. Kassera förbrukade batterier i enlighet med tillverkarens anvisningar.

Product Disposal



Warning! Ultimate disposal of this product should be handled according to all national laws and regulations.

تحذير! يجب التخلص النهائي من هذا المنتج وفقاً لجميع القوانين واللوائح الوطنية.

警告！本产品的废弃处理应根据所有国家的法律和规章进行。

警告！本產品的廢棄處理應根據所有國家的法律和規章進行。

Advarsel! Dette produkt skal bortskaffes i henhold til alle nationale love og regler.

Waarschuwing! De uiteindelijke verwijdering van dit product dient te geschieden in overeenstemming met alle nationale wetten en voorschriften.

Varoitus! Tämän tuotteen lopullinen hävittäminen on suoritettava kaikkien kansallisten lakien ja määräysten mukaisesti.

Attention! La mise au rebut ou le recyclage de ce produit sont généralement soumis à des lois et/ou directives de respect de l'environnement. Renseignez-vous auprès de l'organisme compétent.

Warnung! Die endgültige Entsorgung dieses Produkts muss gemäß allen nationalen Gesetzen und Vorschriften erfolgen.

אזהרה! סילוק סופי של מוצר זה חייב להתבצע בהתאם לכל החוקים והתקנות הלאומיים.

चेतावनी! इस उत्पाद का अंतिम निपटान सभी राष्ट्रीय कानूनों और नियमों के अनुसार किया जाना चाहिए।

警告! この製品を廃棄処分する場合、国の関係する全ての法律・条例に従い処理する必要があります。

경고! 이 제품은 해당 국가의 관련 법규 및 규정에 따라 폐기되어야 합니다.

Advarsel! Når produktet til slutt skal kasseres, må det håndteres i henhold til alle nasjonale lover og forskrifter.

¡Advertencia! Al deshacerse por completo de este producto debe seguir todas las leyes y reglamentos nacionales.

Varning! Slutgiltigt bortskaffande av denna produkt ska ske i enlighet med alla nationella lagar och förordningar.