

**SUPER**●<sup>®</sup>

**C9Z390-PGW**

**USER'S MANUAL**

**Revision 1.0b**

---

---

The information in this User's Manual has been carefully reviewed and is believed to be accurate. The vendor assumes no responsibility for any inaccuracies that may be contained in this document, makes no commitment to update or to keep current the information in this manual, or to notify any person or organization of the updates. **Please Note: For the most up-to-date version of this manual, please see our website at [www.supermicro.com](http://www.supermicro.com).**

Super Micro Computer, Inc. ("Supermicro") reserves the right to make changes to the product described in this manual at any time and without notice. This product, including software and documentation, is the property of Supermicro and/or its licensors, and is supplied only under a license. Any use or reproduction of this product is not allowed, except as expressly permitted by the terms of said license.

**IN NO EVENT WILL SUPERMICRO BE LIABLE FOR DIRECT, INDIRECT, SPECIAL, INCIDENTAL, SPECULATIVE OR CONSEQUENTIAL DAMAGES ARISING FROM THE USE OR INABILITY TO USE THIS PRODUCT OR DOCUMENTATION, EVEN IF ADVISED OF THE POSSIBILITY OF SUCH DAMAGES. IN PARTICULAR, SUPERMICRO SHALL NOT HAVE LIABILITY FOR ANY HARDWARE, SOFTWARE, OR DATA STORED OR USED WITH THE PRODUCT, INCLUDING THE COSTS OF REPAIRING, REPLACING, INTEGRATING, INSTALLING OR RECOVERING SUCH HARDWARE, SOFTWARE, OR DATA.**

Any disputes arising between manufacturer and customer shall be governed by the laws of Santa Clara County in the State of California, USA. The State of California, County of Santa Clara shall be the exclusive venue for the resolution of any such disputes. Super Micro's total liability for all claims will not exceed the price paid for the hardware product.

FCC Statement: This equipment has been tested and found to comply with the limits for a Class B digital device pursuant to Part 15 of the FCC Rules. These limits are designed to provide reasonable protection against harmful interference when the equipment is operated in a consumer environment or residential installation. This equipment generates, uses, and can radiate radio frequency energy and, if not installed and used in accordance with the manufacturer's instruction manual, may cause harmful interference with radio communications. Operation of this equipment in a residential area is likely to cause harmful interference, in which case you will be required to correct the interference at your own expense.

California Best Management Practices Regulations for Perchlorate Materials: This Perchlorate warning applies only to products containing CR (Manganese Dioxide) Lithium coin cells. "Perchlorate Material-special handling may apply. See [www.dtsc.ca.gov/hazardouswaste/perchlorate](http://www.dtsc.ca.gov/hazardouswaste/perchlorate)"



**WARNING:** This product can expose you to chemicals including lead, known to the State of California to cause cancer and birth defects or other reproductive harm. For more information, go to [www.P65Warnings.ca.gov](http://www.P65Warnings.ca.gov).

Manual Revision 1.0b

Release Date: June 07, 2022

Unless you request and receive written permission from Super Micro Computer, Inc., you may not copy any part of this document.

Information in this document is subject to change without notice. Other products and companies referred to herein are trademarks or registered trademarks of their respective companies or mark holders.

Copyright © 2022 by Super Micro Computer, Inc. All rights reserved.

**Printed in the United States of America**

## Preface

This manual is written for system integrators, PC technicians, and knowledgeable PC users. It provides information for the installation and use of the **SUPER** C9Z390-PGW motherboard.

### Manual Organization

**Chapter 1** describes the features, specifications and performance of the motherboard, and provides detailed information on the Intel® Z390 chipset.

**Chapter 2** provides hardware installation instructions. Read this chapter when installing the processor, memory modules and other hardware components into the system.

If you encounter any problems, see **Chapter 3**, which describes troubleshooting procedures for video, memory and system setup stored in the CMOS.

**Chapter 4** includes an introduction to the BIOS, and provides detailed information on running the CMOS Setup utility.

**Appendix A** provides BIOS Error Beep Codes.

**Appendix B** lists software program installation instructions.

**Appendix C** contains UEFI BIOS Recovery instructions.

## Checklist

Congratulations on purchasing your computer motherboard from an acknowledged leader in the industry. Supermicro boards are designed with the utmost attention to detail to provide you with the highest standards in quality and performance.

Please check that the following items have all been included with your motherboard. If anything listed here is damaged or missing, contact your retailer.

The following items are included in the retail box:

- One (1) Supermicro Motherboard
- Four (4) SATA cables
- One (1) I/O shield
- One (1) Quick Reference Guide
- One (1) Driver CD
- Two (2) Antennas

## Conventions Used in the Manual

Special attention should be given to the following symbols for proper installation and to prevent damage done to the components or injury to yourself:



**Attention!** Critical information to prevent damage to the components or injury to yourself.



**Important:** Important information given to ensure proper system installation or to relay safety precautions.



**Note:** Additional Information given to differentiate various models or provides information for correct system setup.

## Standardized Warning Statements

The following statements are industry-standard warnings, provided to warn the user of situations which have the potential for bodily injury. Should you have questions or experience difficulty, contact Supermicro's Technical Support department for assistance. Only certified technicians should attempt to install or configure components.

Read this section in its entirety before installing or configuring components in the Supermicro chassis.

### Battery Handling



#### Warning!

There is a danger of explosion if the battery is replaced incorrectly. Replace the battery only with the same or equivalent type recommended by the manufacturer. Dispose of used batteries according to the manufacturer's instructions

電池の取り扱い

電池交換が正しく行われなかった場合、破裂の危険性があります。交換する電池はメーカーが推奨する型、または同等のものを使用下さい。使用済電池は製造元の指示に従って処分して下さい。

#### 警告

電池更換不當會有爆炸危險。請只使用同類電池或製造商推薦的功能相當的電池更換原有電池。請按製造商的說明處理廢舊電池。

#### 警告

電池更換不當會有爆炸危險。請使用製造商建議之相同或功能相當的電池更換原有電池。請按照製造商的說明指示處理廢棄舊電池。

#### Warnung

Bei Einsetzen einer falschen Batterie besteht Explosionsgefahr. Ersetzen Sie die Batterie nur durch den gleichen oder vom Hersteller empfohlenen Batterietyp. Entsorgen Sie die benutzten Batterien nach den Anweisungen des Herstellers.

#### Attention

Danger d'explosion si la pile n'est pas remplacée correctement. Ne la remplacer que par une pile de type semblable ou équivalent, recommandée par le fabricant. Jeter les piles usagées conformément aux instructions du fabricant.

### ¡Advertencia!

Existe peligro de explosión si la batería se reemplaza de manera incorrecta. Reemplazar la batería exclusivamente con el mismo tipo o el equivalente recomendado por el fabricante. Desechar las baterías gastadas según las instrucciones del fabricante.

### אזהרה!

קיימת סכנת פיצוץ של הסוללה במידה והוחלפה בדרך לא תקינה. יש להחליף את הסוללה בסוג התואם מחברת יצרן מומלצת.

סילוק הסוללות המשומשות יש לבצע לפי הוראות היצרן.

هناك خطر من انفجار في حالة استبدال البطارية بطريقة غير صحيحة فعليك استبدال البطارية فقط بنفس النوع أو ما يعادلها كما أوصت به الشركة المصنعة تخلص من البطاريات المستعملة وفقا لتعليمات الشركة الصانعة

### 경고!

배터리가 올바르게 교체되지 않으면 폭발의 위험이 있습니다. 기존 배터리와 동일하거나 제조사에서 권장하는 동등한 종류의 배터리로만 교체해야 합니다. 제조사의 안내에 따라 사용된 배터리를 처리하여 주십시오.

### Waarschuwing

Er is ontploffingsgevaar indien de batterij verkeerd vervangen wordt. Vervang de batterij slechts met hetzelfde of een equivalent type die door de fabrikant aanbevolen wordt. Gebruikte batterijen dienen overeenkomstig fabrieksvoorschriften afgevoerd te worden.

## Product Disposal



### Warning!

Ultimate disposal of this product should be handled according to all national laws and regulations.

## 製品の廃棄

この製品を廃棄処分する場合、国の関係する全ての法律・条例に従い処理する必要があります。

### 警告

本产品的废弃处理应根据所有国家的法律和规章进行。

### 警告

本產品的廢棄處理應根據所有國家的法律和規章進行。

### Warnung

Die Entsorgung dieses Produkts sollte gemäß allen Bestimmungen und Gesetzen des Landes erfolgen.

### iAdvertencia!

Al deshacerse por completo de este producto debe seguir todas las leyes y reglamentos nacionales.

### Attention

La mise au rebut ou le recyclage de ce produit sont généralement soumis à des lois et/ou directives de respect de l'environnement. Renseignez-vous auprès de l'organisme compétent.

## סילוק המוצר

### אזהרה!

סילוק סופי של מוצר זה חייב להיות בהתאם להנחיות וחוקי המדינה.

عند التخلص النهائي من هذا المنتج ينبغي التعامل معه وفقا لجميع القوانين واللوائح الوطنية

### 경고!

이 제품은 해당 국가의 관련 법규 및 규정에 따라 폐기되어야 합니다.

### Waarschuwing

De uiteindelijke verwijdering van dit product dient te geschieden in overeenstemming met alle nationale wetten en reglementen.

## Contacting Supermicro

### Headquarters

Address: Super Micro Computer, Inc.  
980 Rock Ave.  
San Jose, CA 95131 U.S.A.

Tel: +1 (408) 503-8000

Fax: +1 (408) 503-8008

Email: [marketing@supermicro.com](mailto:marketing@supermicro.com) (General Information)  
[support@supermicro.com](mailto:support@supermicro.com) (Technical Support)

Website: [www.supermicro.com](http://www.supermicro.com)

### Europe

Address: Super Micro Computer B.V.  
Het Sterrenbeeld 28, 5215 ML  
's-Hertogenbosch, The Netherlands

Tel: +31 (0) 73-6400390

Fax: +31 (0) 73-6416525

Email: [sales@supermicro.nl](mailto:sales@supermicro.nl) (General Information)  
[support@supermicro.nl](mailto:support@supermicro.nl) (Technical Support)  
[rma@supermicro.nl](mailto:rma@supermicro.nl) (Customer Support)

Website: [www.supermicro.nl](http://www.supermicro.nl)

### Asia-Pacific

Address: Super Micro Computer, Inc.  
3F, No. 150, Jian 1st Rd.  
Zhonghe Dist., New Taipei City 235  
Taiwan (R.O.C)

Tel: +886-(2) 8226-3990

Fax: +886-(2) 8226-3992

Email: [support@supermicro.com.tw](mailto:support@supermicro.com.tw)

Website: [www.supermicro.com.tw](http://www.supermicro.com.tw)

## Where to Find More Information

For your system to work properly, please follow the links below to download all necessary drivers/utilities and the user's manual for your motherboard.

Supermicro product manuals: <http://www.supermicro.com/support/manuals/>

Product Drivers and utilities: <https://www.supermicro.com/wftp/driver/>

A secure data deletion tool designed to fully erase all data from storage devices can be found at our website: [https://www.supermicro.com/about/policies/disclaimer.cfm?url=/wftp/utility/Lot9\\_Secure\\_Data\\_Deletion\\_Utility/](https://www.supermicro.com/about/policies/disclaimer.cfm?url=/wftp/utility/Lot9_Secure_Data_Deletion_Utility/)

If you have any questions, please contact our support team at [support@supermicro.com](mailto:support@supermicro.com).

# Table of Contents

## Preface

### Chapter 1 Introduction

1-1	Overview .....	1-1
1-2	Chipset Overview .....	1-1
1-3	Motherboard Features .....	1-2
1-4	Special Features .....	1-4
1-5	PC Health Monitoring.....	1-4
1-6	ACPI Features .....	1-5
1-7	Power Supply .....	1-6
1-8	Super I/O .....	1-6

### Chapter 2 Installation

2-1	Installation Components and Tools Needed .....	2-1
2-2	Static-Sensitive Devices.....	2-2
2-3	Processor and Heatsink Installation.....	2-3
2-4	Installing DDR4 Memory .....	2-8
2-4	M.2 Installation (optional).....	2-11
2-5	Motherboard Installation.....	2-12
2-6	Connectors/IO Ports.....	2-14
2-7	Connecting Cables .....	2-22
2-8	Jumper Settings .....	2-30
2-9	Onboard Indicators .....	2-34
2-10	Hard Drive Connections.....	2-36

### Chapter 3 Troubleshooting

3-1	Troubleshooting Procedures.....	3-1
3-2	Technical Support Procedures.....	3-3
3-3	Frequently Asked Questions .....	3-4
3-4	Battery Removal and Installation .....	3-5
3-5	Returning Motherboard for Service.....	3-6

### Chapter 4 UEFI BIOS

4-1	Introduction .....	4-1
4-2	EZ Mode.....	4-3
4-3	Overclocking .....	4-5
4-4	CPU .....	4-20
4-5	Memory.....	4-26
4-6	Advanced.....	4-28

---

---

4-7	H/W Monitor .....	4-47
4-8	Save & Exit.....	4-49
4-9	BIOS Update .....	4-51

**Appendix A BIOS Error Beep Codes**

A-1	BIOS Error Beep Codes .....	A-1
-----	-----------------------------	-----

**Appendix B Software Installation Instructions**

B-1	Installing Drivers .....	B-1
B-2	Configuring SuperDoctor <sup>®</sup> 5 .....	B-2

**Appendix C UEFI BIOS Recovery Instructions**

C-1	An Overview to the UEFI BIOS .....	C-1
C-2	How to Recover the UEFI BIOS Image (the Main BIOS Block) .....	C-1
C-3	To Recover the Main BIOS Block Using a USB-Attached Device.....	C-2

## Notes

# Chapter 1

## Introduction

### 1-1 Overview

#### About this Motherboard

The C9Z390-PGW motherboard supports a single 8th/9th Generation Intel® Core™ i9/i7/i5/i3/Pentium®/Celeron® processor in an LGA 1151 (H4) socket. With the Intel Z390 Express chipset built in, the C9Z390-PGW motherboard offers substantial system performance and storage capability for overclocking platforms in a sleek package. Please refer to our website (<http://www.supermicro.com/products/>) for processor and memory support updates.

### 1-2 Chipset Overview

#### Intel Z390 Chipset Features

- Direct Media Interface (up to 10 Gb/s transfer, Full Duplex)
- Intel Matrix Storage Technology and Intel Rapid Storage Technology
- Dual NAND Interface
- Intel I/O Virtualization (VT-d) Support
- Intel Trusted Execution Technology Support
- PCI-E 3.0 Interface (up to 8 GT/s)
- SATA Controller (up to 6Gb/sec)
- Advanced Host Controller Interface (AHCI)

## 1-3 Motherboard Features

<b>CPU</b>	Single 8th/9th Gen. Intel Core i9/i7/i5/i3/Pentium/Celeron processor in an LGA 1151 (H4) type socket	
<b>Memory</b>	Four (4) slots support up to 128GB (available only for selected 9th Gen. processors) of unbuffered, non-ECC, 2666/2400 MHz or 4000+MHz (OC) DDR4 memory	
	Dual-channel memory	
	<b>DIMM sizes</b>	
	UDIMM	4GB/8GB/16GB; 32GB (available only for selected 9th Gen. processors)
<b>Chipset</b>	Intel Z390	
<b>Expansion Slots</b>	Four (4) PCI-E 3.0 x16 slots (16/NA/16/NA or 8/8/8/8 or 8/8/16/NA or NA/16/8/8)	
	One (1) PCI-E 3.0 x1 slot	
	Two (2) M.2 M-key (1 PCI-E x4, 1 PCI-E/SATA) (One 2260/2280/22110, One 2260/2280)	
	One (1) M.2 E-key (Pre-installed 802.11ac WiFi & Bluetooth module)	
<b>Network Connections</b>	One (1) Intel i219v 1G LAN port One (1) AQC 10G LAN port	
<b>I/O Devices</b>	<b>Hard Drive Connections</b>	
	SATA 3.0 (6Gb/s)	Six (6) I-SATA0~5 connectors, via Intel Z390
		RAID 0, 1, 5, and 10
	U.2 Connectors	Two (2) U.2 connectors for 2.5" SSD Drives
	M.2 Connectors	Two (2) M.2 connectors
	<b>USB Devices</b>	
	Four (4) USB 3.1 Gen. 2 ports on the back panel (USB 5: Type C, USB 4/6/7: Type A)	
	Two (2) USB 3.1 Gen. 1 ports on the back panel	
	One (1) front panel USB 3.1 Gen. 2 Type C header	
	Two (2) front panel USB 3.1 Gen. 1 connections via one header	
	Two (2) front accessible USB 2.0 connections via one header	
	<b>Keyboard/Mouse</b>	
	One shared PS/2 Keyboard/Mouse port on the back panel	
<b>Other I/O Ports</b>		
Two (2) DisplayPort 1.2 ports		
One (1) HDMI 2.0a port		
One (1) Serial port header (COM1)		

	<p style="text-align: center;"><b>Audio</b></p> <p>One (1) High Definition Audio 7.1 channel connector supported by Realtek ALC1220 on the back panel</p> <p>One (1) Front Panel Audio header</p> <p>One (1) S/PDIF Out on the rear side of the chassis</p> <p style="text-align: center;"><b>Super I/O</b></p> <p>Nuvoton NCT6792D-B</p>
<b>BIOS</b>	<p>256 Mb AMI BIOS® SPI Flash BIOS</p> <p>ACPI 3.0, SMBIOS 2.7, BIOS rescue hot-key, SPI dual/quad speed support, and Overclock support</p>
<b>Power Configuration</b>	<p>ACPI Power Management (S3, S4, and S5)</p> <p>Power Button Override Mechanism</p> <p>Internal/External Modem Ring-on</p> <p>Power-on mode for AC power recovery</p>
<b>Health Monitoring</b>	<p style="text-align: center;"><b>CPU Monitoring</b></p> <p>Onboard monitors: +1.8V, +3.3V, +5V, +/- 12V, +3.3V Stby, +5V Stby, VBAT, HT, PCH Temperature, System Temperature, and Memory Temperature</p> <p>CPU 6-phase switching voltage regulator</p> <p>CPU/System overheat LED and control</p> <p>CPU Thermal Trip support</p> <p style="text-align: center;"><b>Fan Control</b></p> <p>Five (5) 4-pin fan headers</p> <p>Fan status monitoring with firmware fan speed control</p> <p>Multi-speed fan control via onboard Super I/O</p>
<b>System Management</b>	<p>PECI (Platform Environment Configuration Interface) 2.0 support</p> <p>System resource alert via SuperDoctor® 5</p> <p>SuperDoctor 5</p> <p>Chassis Intrusion header and detection</p>
<b>CD Utilities</b>	<p>BIOS flash upgrade utility</p> <p>Drivers and software for Intel Z390 Express chipset utilities</p>
<b>Other</b>	ROHS 6/6 (Full Compliance, Lead Free)
<b>Dimensions</b>	ATX form factor (12.0" x 9.6") (304.8 mm x 243.84 mm)

## 1-4 Special Features

### Recovery from AC Power Loss

Basic I/O System (BIOS) provides a setting for you to determine how the system will respond when AC power is lost and then restored to the system. You can choose for the system to remain powered off, (in which case you must press the power switch to turn it back on), or for it to automatically return to a power-on state. See the Advanced BIOS Setup section to change this setting. The default setting is **Last State**.

## 1-5 PC Health Monitoring

This section describes the PC health monitoring features of the board. All have an onboard System Hardware Monitoring chip that supports PC health monitoring. An onboard voltage monitor will scan these onboard voltages continuously: +1.8V, +3.3V, +5V, +/- 12V, +3.3V Stby, +5V Stby, VBAT, HT, Memory PCH Temperature, System Temperature, and Memory Temperature. Once a voltage becomes unstable, a warning is given, or an error message is sent to the screen. The user can adjust the voltage thresholds to define the sensitivity of the voltage monitor.

### Fan Status Monitor with Firmware Control

PC health monitoring in the BIOS can check the RPM status of the cooling fans. The onboard CPU and chassis fans are controlled by Thermal Management via SIO.

### Environmental Temperature Control

The thermal control sensor monitors the CPU temperature in real time and will turn on the thermal control fan whenever the CPU temperature exceeds a user-defined threshold. The overheat circuitry runs independently from the CPU. Once the thermal sensor detects that the CPU temperature is too high, it will automatically turn on the thermal fans to prevent the CPU from overheating. The onboard chassis thermal circuitry can monitor the overall system temperature and alert the user when the chassis temperature is too high.



**Note:** To avoid possible system overheating, please be sure to provide adequate airflow for your system.

## **System Resource Alert**

This feature is available when the system is used with SuperDoctor 5 in the Windows and Linux operating systems. SuperDoctor is used to notify the user of certain system events. For example, you can also configure SuperDoctor to provide you with warnings when the system temperature, CPU temperatures, voltages and fan speeds go beyond predefined thresholds.

## **1-6 ACPI Features**

ACPI stands for Advanced Configuration and Power Interface. The ACPI specification defines a flexible and abstract hardware interface that provides a standard way to integrate power management features throughout a PC system, including its hardware, operating system and application software. This enables the system to automatically turn on and off peripherals, such as CD-ROMs, network cards, hard disk drives and printers.

In addition to enabling operating system-directed power management, ACPI also provides a generic system event mechanism for Plug and Play, and an operating system-independent interface for configuration control. ACPI leverages the Plug and Play BIOS data structures, while providing a processor architecture-independent implementation that is compatible with Windows 7, Windows 8, and Windows 2008 Operating Systems.

### **Slow Blinking LED for Suspend-State Indicator**

When the CPU goes into a suspend state, the chassis power LED will start to blink to indicate that the CPU is in suspend mode. When the user presses any key, the CPU will "wake up," and the LED will automatically stop blinking and remain on.

## 1-7 Power Supply

As with all computer products, a stable power source is necessary for proper and reliable operation. It is even more important for processors that have high CPU clock rates.

This motherboard accommodates a 24-pin ATX power supply. Although most power supplies generally meet the specifications required by the CPU, some are inadequate. In addition, the 12V 8-pin power connector located at JPW2 is also required to ensure adequate power supply to the system. Also your power supply must supply 1.5A for the Ethernet ports.

**! Attention!** To prevent damage to the power supply or motherboard, please use power supplies that contain 24-pin and 8-pin power connectors. Be sure to connect these connectors to the 24-pin (JPW1) and the 8-pin (JPW2) power connectors on the motherboard.

It is strongly recommended that you use a high quality power supply that meets ATX power supply Specification 2.02 or above. It must also be SSI compliant. (For more information, please refer to the website at <http://www.ssiforum.org/>). Additionally, in areas where noisy power transmission is present, you may choose to install a line filter to shield the computer from noise. It is recommended that you also install a power surge protector to help avoid problems caused by power surges.

## 1-8 Super I/O

The Super I/O supports one high-speed, 16550 compatible serial communication port (UART). Each UART includes a 16-byte send/receive FIFO, a programmable baud rate generator, complete modem control capability and a processor interrupt system. The UART provides legacy speed with a baud rate of up to 115.2 Kbps as well as an advanced speed with baud rates of 250 K, 500 K, or 1 Mb/s, which support higher speed modems.

The Super I/O provides functions that comply with ACPI (Advanced Configuration and Power Interface), which includes support of legacy and ACPI power management through an SMI or SCI function pin. It also features auto power management to reduce power consumption.

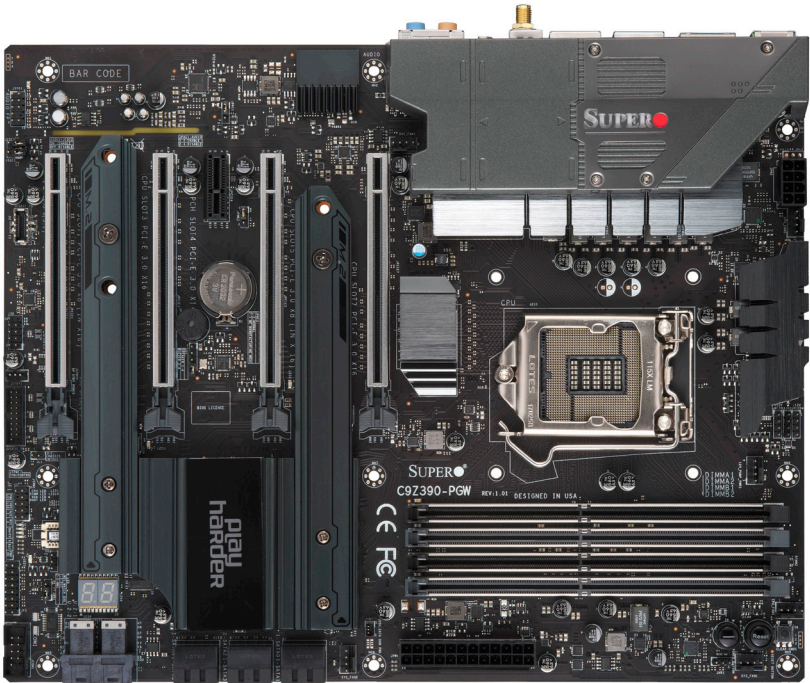
**C9Z390-PGW Motherboard Image**

**Note:** All graphics shown in this manual were based upon the latest PCB Revision available at the time of publishing of the manual. The motherboard you've received may or may not look exactly the same as the graphics shown in this manual.

**C9Z390-PGW Motherboard Layout**

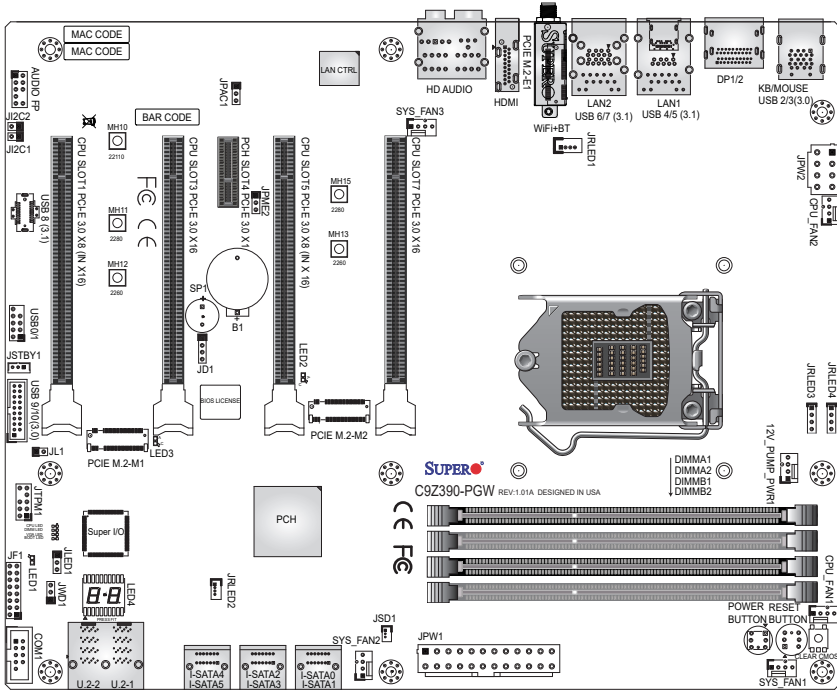

**Important Notes to the User**

- See Chapter 2 for detailed information on jumpers, I/O ports and JF1 front panel connections.
- "■" indicates the location of "Pin 1".
- Jumpers not indicated are for testing only.
- When LED1 (Onboard Power LED Indicator) is on, system power is on. Unplug the power cable before installing or removing any components.

## C92390-PGW Block Diagram

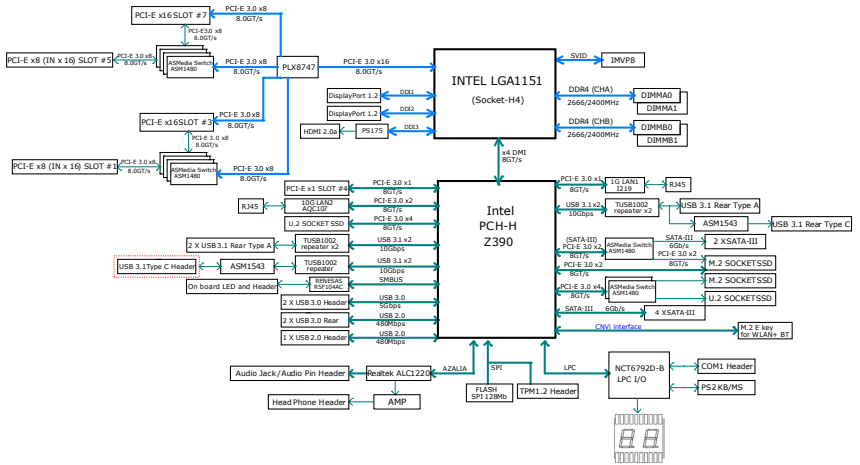

**C9Z390-PGW Quick Reference**

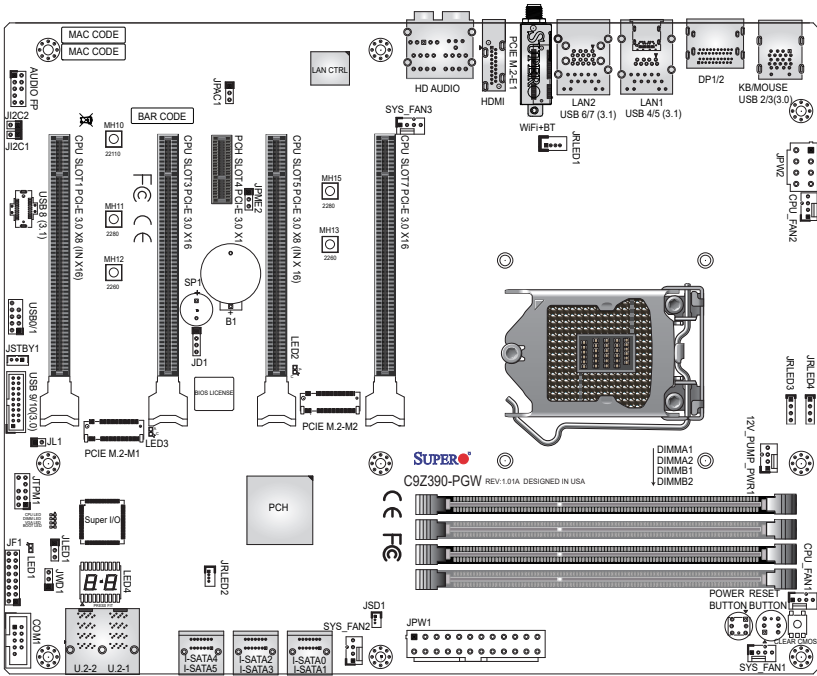

<b>Jumper</b>	<b>Description</b>	<b>Default</b>
CLEAR CMOS	Clear CMOS Switch	Push Button Switch
J12C1/J12C2	SMB to PCI Slots	Open (Disable)
JPAC1	Audio Enable/Disable	Pins 1-2 (Enabled)
JPME2	Intel Manufacturing Mode	Pins 1-2 (Normal)
JWD1	Watch Dog Function Enable	Pins 1-2 (RST)
POWER BUTTON	Internal Power Button	Push Button Switch
RESET BUTTON	Onboard System Reset Button	Push Button Switch

Connector	Description
12V_PUMP_PWR1	12V 4-pin Power Connector for CPU pump of liquid cooling
AUDIO FP	Front Panel Audio Header
B1	Onboard Battery
COM1	COM1 Header
CPU SLOT1/SLOT5 PCI-E 3.0 x8 (IN x16)	PCI-Express x16 Slots (PCI-E 3.0 x8 link)
CPU SLOT3/SLOT7 PCI-E 3.0 x16	PCI-Express x16 Slots (PCI-E 3.0 x16 link)
PCH SLOT4 PCI-E 3.0 x1	PCI-Express x1 Slot (PCI-E 3.0 x1 link)
HD AUDIO	High Definition Audio Ports
HDMI	High Definition Multimedia Interface up to 2.0a
DP1/DP2	DisplayPort 1.2 Ports
I-SATA0~5	Intel Z390 Serial ATA (SATA 3.0) Ports 0-5 (6Gb/sec)
JD1	Speaker/Buzzer (Pins 1-4: External Speaker, Pins 3-4: Buzzer)
JF1	Front Control Panel Header
JL1	Chassis Intrusion Header
JLED1	Power LED Indicator Header
JPW1	24-pin ATX Main Power Connector (Required)
JPW2	+12V 8-pin CPU power Connector (Required)
JRLED1/JRLED2	JRLED1 connects to I/O cover's RGB board JRLED2 connects to PCH RGB board
JRLED3/JRLED4	External 12V RGB strip Headers (see Chapter 2 for installation instructions)
JSD1	SATA DOM (Disk-On-Module) Power Connector
JSTBY1	Standby Power Header
JTPM1	Trusted Platform Module (TPM) Header
KB/MOUSE	PS/2 Keyboard/Mouse Port
LAN1/LAN2	RJ45 1GbE/10GbE LAN Ports
PCI-E M.2-E1	PCI-E M.2 Connector E1 for WiFi module (pre-installed)

Connector	Description
PCI-E M.2-M1/M.2-M2	PCI-E M.2 Connectors M1 and M2. Small form factor devices and other portable devices for high speed NVMe SSDs *M.2-M1 port shares lanes with U.2-1 port. M.2-M2 port shares lanes with I-SATA4 and I-SATA5 *RAID 0,1
SYS_FAN1/FAN2/ FAN3, CPU_FAN1/ FAN2	System/CPU Headers
U.2-1/U.2-2	U.2 Connector 1 and 2, for 2.5" SSD Drives *U.2-1 port shares lanes with M.2-M1 port *RAID 0,1
USB 0/1	Front Panel Accessible USB 2.0 Header (Black)
USB 2/3	Back Panel USB 3.1 Gen1 Ports (Blue)
USB 4/5, 6/7	Back Panel USB 3.1 Gen2 Ports, USB 4/6/7: Type A (Red), USB 5: Type C
USB 8	Front Panel Accessible USB 3.1 Gen2 Header (Type C)
USB 9/10	Front Panel Accessible USB 3.1 Gen1 Header (Black)

LED	Description	Color/State
BOOT LED	Bootable Device POST Status	Red ON: BOOT POST Activity
CPU LED	CPU POST Status	Yellow ON: CPU POST Activity
DIMM LED	DIMM POST Status	Blue ON: DIMM POST Activity
LED1	Onboard Standby PWR LED	Green ON: On
LED2	PCI-E M.2 Connector 2 LED	Green Blinking: Activity
LED3	PCI-E M.2 Connector 1 LED	Green Blinking: Activity
LED4	Diagnostic LED*	Digital Readout
VGA LED	Onboard VGA POST Status	Green ON: VGA POST Activity

\*Download the AMI status codes at [https://www.supermicro.com/manuals/other/AMI\\_AptioV\\_BIOS\\_POST\\_Codes\\_for\\_SM\\_Motherboards.pdf](https://www.supermicro.com/manuals/other/AMI_AptioV_BIOS_POST_Codes_for_SM_Motherboards.pdf).

## Chapter 2

### Installation

#### 2-1 Installation Components and Tools Needed

Screws

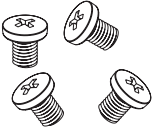

Phillips-Head Screwdriver

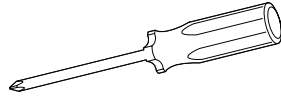

Intel LGA 1151 Processor

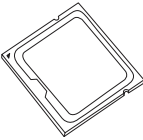

DDR4 DIMMs

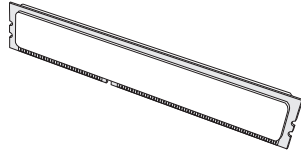

PC Chassis

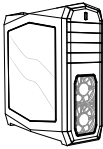

Heatsink with Fan

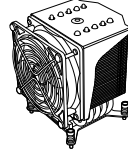

Power Supply

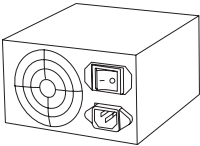

Video Card (Optional)

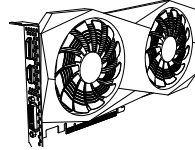

SATA/USB Optical Drive (Optional)

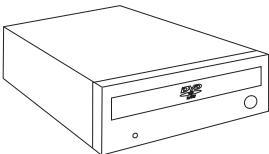

SATA Hard Disk Drive

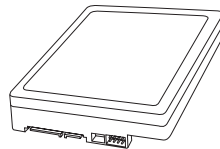

## 2-2 Static-Sensitive Devices

Electrostatic Discharge (ESD) can damage electronic components. To avoid damaging your system board, it is important to handle it very carefully. The following measures are generally sufficient to protect your equipment from ESD.

### Precautions

- Use a grounded wrist strap designed to prevent static discharge.
- Touch a grounded metal object before removing the board from the antistatic bag.
- Handle the board by its edges only; do not touch its components, peripheral chips, memory modules or gold contacts.
- When handling chips or modules, avoid touching their pins.
- Put the motherboard and peripherals back into their antistatic bags when not in use.
- For grounding purposes, make sure your computer chassis provides excellent conductivity between the power supply, the case, the mounting fasteners and the motherboard.
- Use only the correct type of onboard CMOS battery. Do not install the onboard battery upside down to avoid possible explosion.

### Unpacking

The motherboard is shipped in antistatic packaging to avoid static damage. When unpacking the board, make sure that the person handling it is static protected.

## 2-3 Processor and Heatsink Installation

**!** **Attention!** When handling the processor package, avoid placing direct pressure on the label area of the fan.



### Important:

Always connect the power cord last, and always remove it before adding, removing or changing any hardware components. Make sure that you install the processor into the CPU socket before you install the CPU heatsink.

If you buy a CPU separately, make sure that you use an Intel-certified multi-directional heatsink only.

Make sure to install the system board into the chassis before you install the CPU heatsink.

When receiving a server board without a processor pre-installed, make sure that the plastic CPU socket cap is in place and none of the socket pins are bent; otherwise, contact your retailer immediately.

Refer to the Supermicro website for updates on CPU support.

### Installing the LGA1151 Processor

1. Press the load lever to release the load plate, which covers the CPU socket, from its locking position.

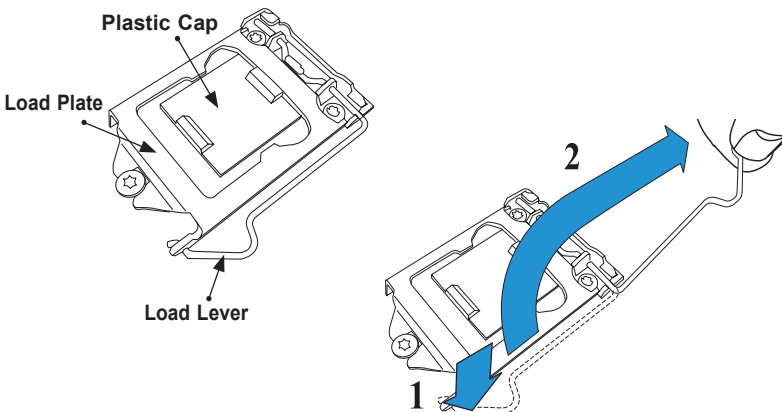

2. Gently lift the load lever to open the load plate. Remove the plastic cap.

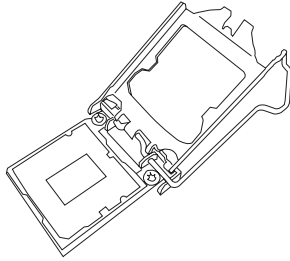

3. Use your thumb and your index finger to hold the CPU at the North center edge and the South center edge of the CPU.

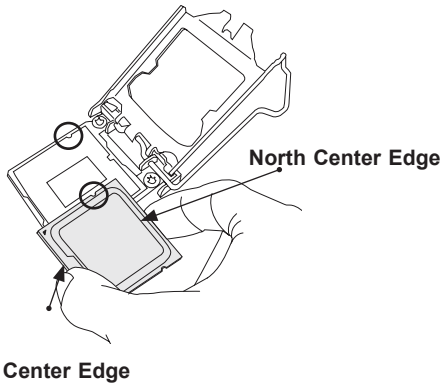

4. Align the small triangle marker on the CPU to its corresponding triangle marker on the load bracket. Once it is aligned, carefully lower the CPU straight down into the socket. (Do not drop the CPU on the socket, or move it horizontally or vertically.)

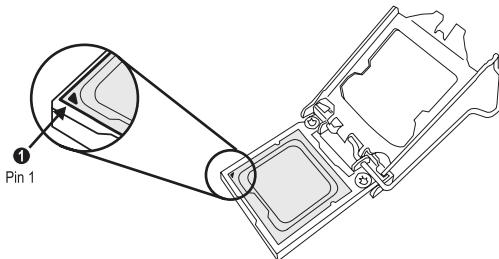

5. Do not rub the CPU against the surface or against any pins of the socket to avoid damaging the CPU or the socket.)
6. With the CPU inside the socket, inspect the four corners of the CPU to make sure that the CPU is properly installed.
7. Use your thumb to gently push the load lever down to the lever lock.
8. Close the load plate with the CPU inside the socket. Lock the "Close 1st" lever first, then lock the "Open 1st" lever second. Gently push the load levers down to the lever locks.

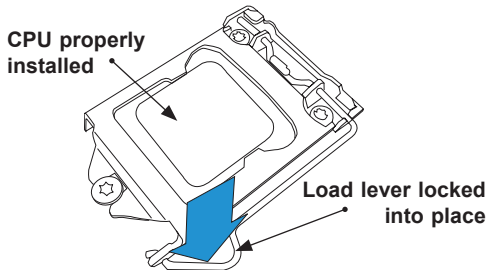

**! Attention!** You can only install the CPU inside the socket in one direction. Make sure that it is properly inserted into the CPU socket before closing the load plate. If it doesn't close properly, do not force it as it may damage your CPU. Instead, open the load plate again and double-check that the CPU is aligned properly.

## Installing an Active CPU Heatsink with Fan

1. Apply the proper amount of thermal grease to the heatsink.
2. Place the heatsink on top of the CPU so that the four mounting holes on the heatsink are aligned with those on the retention mechanism.
3. Tighten the screws in the following order:

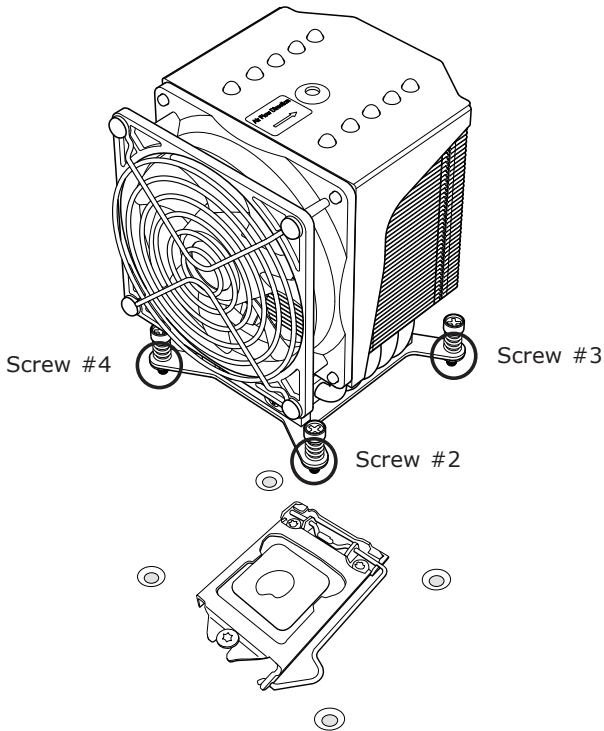

4. Once the screws are tightened, plug the power cord into the FAN1 connector.



**Note:** Screw #1 is not shown in the illustration.

**Note:** Graphic drawings included in this manual are for reference only. They might look different from the components installed in your system.

## Removing an Active CPU Heatsink with Fan

**Warning:** We do not recommend that the CPU or heatsink be removed. However, if you do need to remove the heatsink, please follow the instruction below to uninstall the heatsink to avoid damaging the CPU or other components.

1. Unplug the power cord from the power supply.
2. Loosen the screws in the order below.
3. Gently wiggle the heatsink to loosen it. Do not use excessive force when wiggling the heatsink.

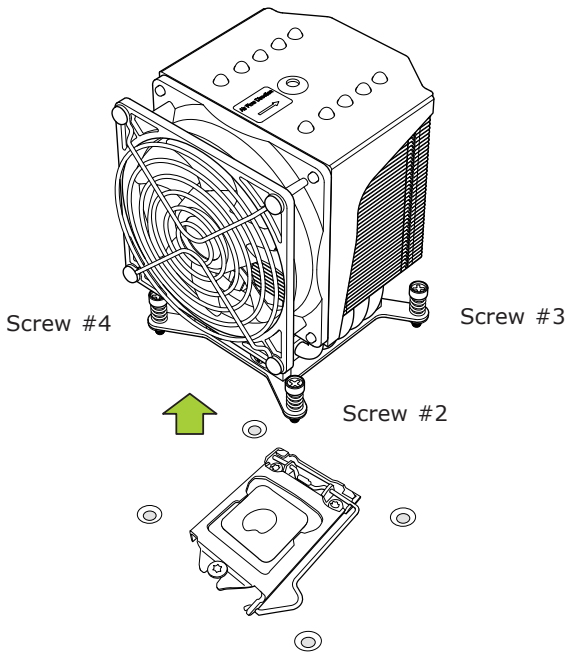

4. Once the heatsink is loosened, remove it from the motherboard.



**Note:** Screw #1 is not shown in the illustration.

## 2-4 Installing DDR4 Memory



**Note:** Check the Supermicro website for recommended memory modules.



**Attention!** Exercise extreme care when installing or removing DIMM modules to prevent any possible damage.

### DIMM Installation

1. Insert the desired number of DIMMs into the memory slots, starting with DIMMA2 and DIMMB2, then DIMMA1 and DIMMB1. For the system to work properly, please use the memory modules of the same type and speed.

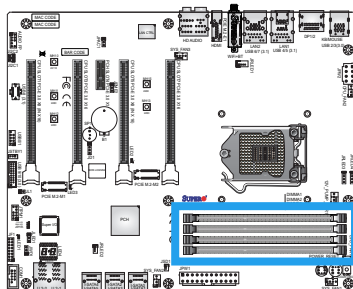

2. Push the release tabs outwards on both ends of the DIMM slot to unlock it.
3. Align the key of the DIMM module with the receptive point on the memory slot.
4. Align the notches on both ends of the module against the receptive points on the ends of the slot.
5. Use two thumbs together to press the notches on both ends of the module straight down into the slot until the module snaps into place.
6. Press the release tabs to the lock positions to secure the DIMM module into the slot.

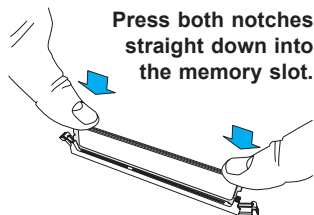
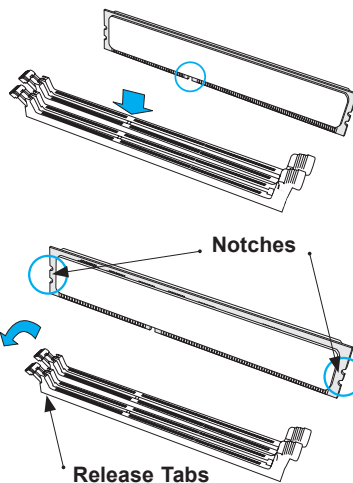

### Removing Memory Modules

Reverse the steps above to remove the DIMM modules from the motherboard.

## Memory Support

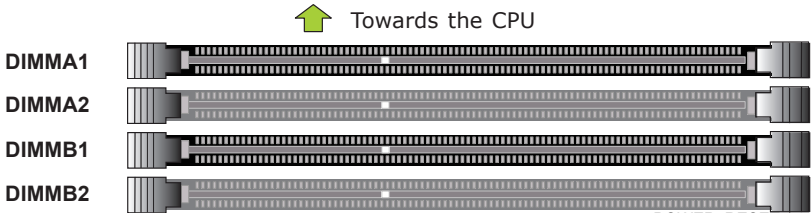

The C9Z390-PGW supports up to 128GB (available only for selected 9th Gen processors) of Unbuffered (UDIMM) non-ECC DDR4 memory, up to 2666/2400MHz or 4000+MHz (OC) in four 288-pin memory slots. Populating these DIMM modules with a pair of memory modules of the same type and size will result in interleaved memory, which will improve memory performance.



**Note:** Be sure to use memory modules of the same type, speed, and frequency on the motherboard. Mixing of memory modules of different types and speeds is not allowed.

## Memory Population Guidelines

When installing memory modules, the DIMM slots should be populated in the following order: DIMMA2, DIMMB2, then DIMMA1, DIMMB1.

- Always use DDR4 DIMM modules of the same size and speed.
- Mixed DIMM speeds can be installed. However, all DIMMs will run at the speed of the slowest DIMM.

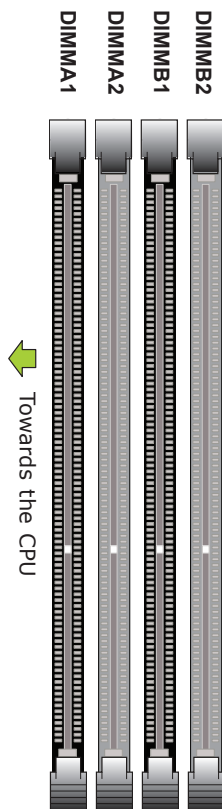

Recommended Population	One DIMM	○	●	○	○
	Two DIMM	○	●	○	●
	Four DIMM	●	●	●	●

## 2-4 M.2 Installation (optional)

Two M.2 (M-key) connectors are supported by the C9Z390-PGW. M.2 devices are used for solid state storage and internal expansion. Follow the steps below in order to install an M.2 device.

1. Locate and remove the retaining screws on the M.2 heatsink.
2. With the heatsink removed, locate the standoff.
3. If required, remove the standoff and move it to appropriate location for M.2 card's length.
4. Carefully plug the M.2 device into the M.2 connector and lower the semi-circle notched end onto the standoff.
5. Remove the M.2 heatsink thermal tape cover.
6. Replace the M.2 heatsink and the retaining screws. Tighten the screws to secure the heatsink into place.

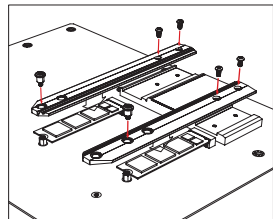
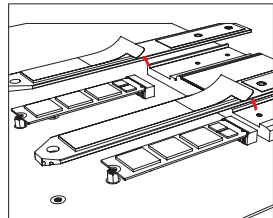
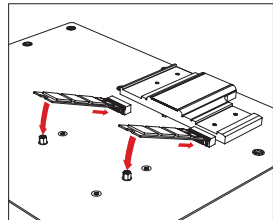
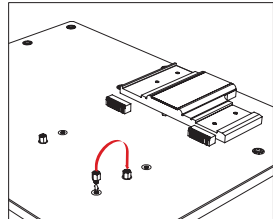
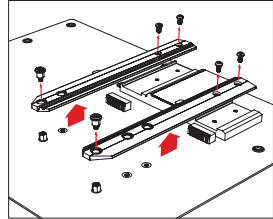

## 2-5 Motherboard Installation

All motherboards have standard mounting holes to fit different types of chassis. Make sure that the locations of all the mounting holes for both motherboard and chassis match. Although a chassis may have both plastic and metal mounting fasteners, metal ones are highly recommended because they ground the motherboard to the chassis. Make sure that the metal standoffs click in or are screwed in tightly. Then use a screwdriver to secure the motherboard onto the motherboard tray.

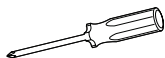

Philips Screwdriver (1)



Philips Screws (9)



Standoffs (9)  
Only if Needed

### Tools Needed

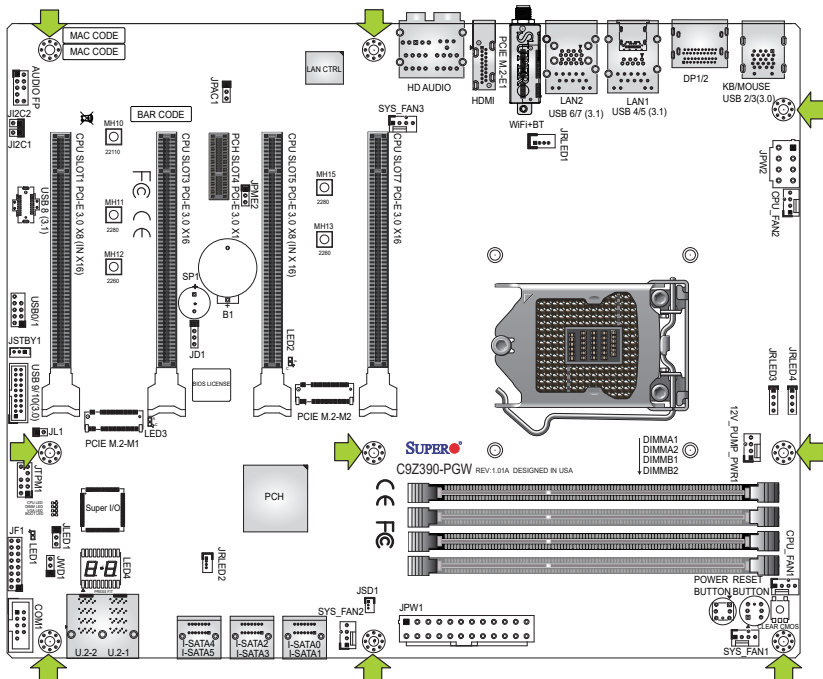

### Location of Mounting Holes

- ! Attention!** 1) To avoid damaging the motherboard and its components, please do not use a force greater than 8 lb/inch on each mounting screw during motherboard installation. 2) Some components are very close to the mounting holes. Please take precautionary measures to avoid damaging these components when installing the motherboard to the chassis.

## Installing the Motherboard

1. Install the I/O shield into the back of the chassis.

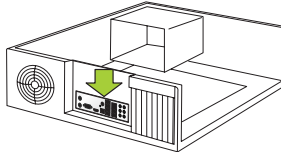

2. Locate the mounting holes on the motherboard. (See the previous page.)
3. Locate the matching mounting holes on the chassis. Align the mounting holes on the motherboard against the mounting holes on the chassis.

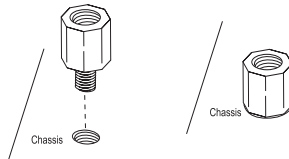

4. Install standoffs in the chassis as needed.
5. Install the motherboard into the chassis carefully to avoid damaging other motherboard components.

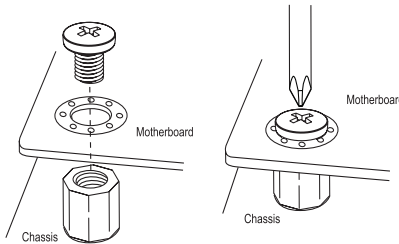

6. Using the Phillips screwdriver, insert a Phillips head #6 screw into a mounting hole on the motherboard and its matching mounting hole on the chassis.
7. Repeat Step 6 to insert remaining screws into all mounting holes.
8. Make sure that the motherboard is securely placed in the chassis.



**Note:** Images displayed are for illustration only. Your chassis or components might look different from those shown in this manual.

## 2-6 Connectors/IO Ports

The I/O ports are color coded in conformance with the industry standards. See the figure below for the colors and locations of the various I/O ports.

Back I/O Panel

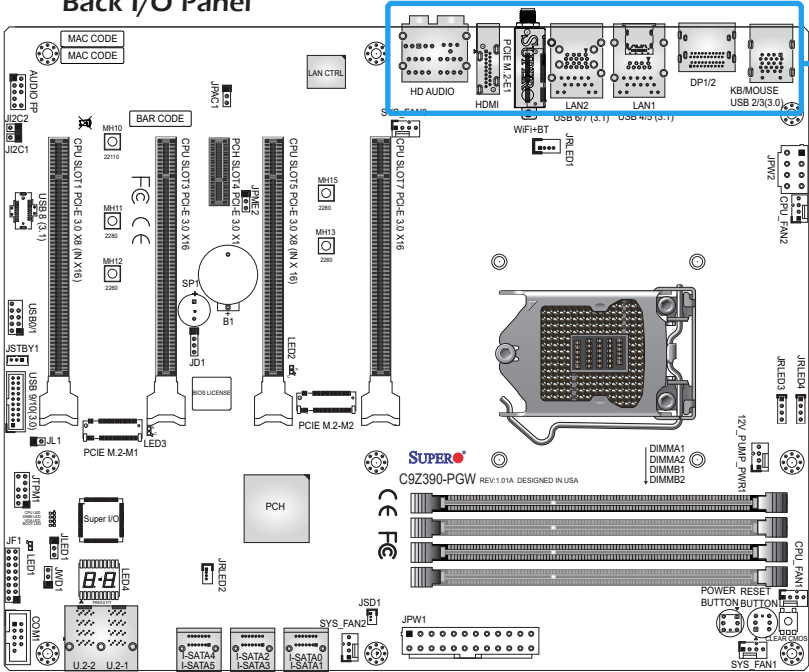

A. PS/2 Keyboard/Mouse Port	G. USB 3.1 Gen 2 Port 4	M. Center/LFE Out
B. USB 3.1 Gen 1 Port 2	H. USB 3.1 Gen 2 Port 5 (Type C)	N. Surround Out
C. USB 3.1 Gen 1 Port 3	I. LAN2	O. S/PDIF Out
D. DisplayPort 1.2 Port 1	J. USB 3.1 Gen 2 Port 6	P. Line In
E. DisplayPort 1.2 Port 2	K. USB 3.1 Gen 2 Port 7	Q. Line Out
F. LAN1	L. HDMI 2.0a Port	R. Mic In

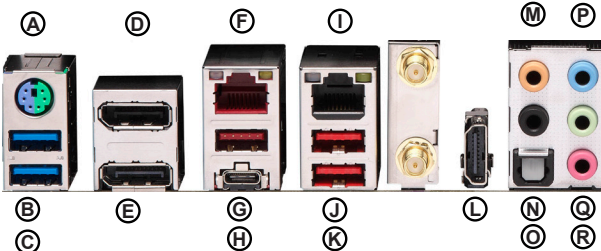

## Universal Serial Bus (USB) Ports

Four USB 3.1 Gen 2 ports (USB 4/5/6/7) and two USB 3.1 Gen 1 ports (USB 2/3) are located on the I/O back panel. In addition, one front panel USB 3.1 Gen 2 header (USB 8), one USB 3.1 Gen 1 header (USB 9/10), and one USB 2.0 header (USB 0/1) are also located on the motherboard to provide front chassis access using USB cables (not included). See the tables below for pin definitions.

Front Panel USB 0/1 (2.0) Pin Definitions			
Pin#	Definition	Pin#	Definition
1	+5V	2	+5V
3	USB_PN2	4	USB_PN3
5	USB_PP2	6	USB_PP3
7	Ground	8	Ground
9	Key	10	Ground

Back Panel USB 2/3 (3.1 Gen 1) USB 4/5/6/7 (3.1 Gen 2) Pin Definitions			
Pin#	Definition	Pin#	Definition
1	+5V	5	+5V
2	USB_PN1	6	USB_PN0
3	USB_PP1	7	USB_PP0
4	Ground	8	Ground

Front Panel USB 9/10 (3.1 Gen 1) Pin Definitions			
Pin#	Pin#	Signal Name	Description
1	10	VBUS	Power
2	11	D-	USB 2.0 Differential Pair
3	12	D+	
4	13	Ground	Ground of PWR Return
5	14	StdA_SSRX-	SuperSpeed Receiver
6	15	StdA_SSRX+	Differential Pair
7	16	GND_DRAIN	Ground for Signal Return
8	17	StdA_SSTX-	SuperSpeed Transmitter
9	18	StdA_SSTX+	Differential Pair

- A. USB 2
- B. USB 3
- C. USB 4
- D. USB 5
- E. USB 6
- F. USB 7
- G. USB 0/1
- H. USB 9/10

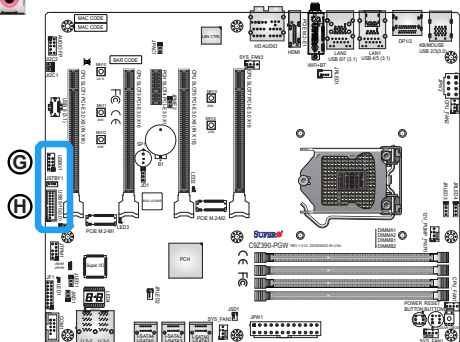
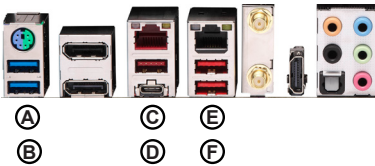



## Back Panel High Definition Audio (HD Audio)

This motherboard features a 7.1+2 Channel High Definition Audio (HDA) codec that provides 10 DAC channels. The HD Audio connections simultaneously supports multiple-streaming 7.1 sound playback with 2 channels of independent stereo output through the front panel stereo out for front, rear, center and subwoofer speakers. Use the Advanced software included in the CD-ROM with your motherboard to enable this function.

Audio Configuration					
		2 Channel	4.1 Channel	5.1 Channel	7.1 Channel
A	Light Blue (Line In/Side Speaker Out)	Line In	Line In	Line In	Side Speaker Out
B	Lime (Line Out/Front Speaker Out)	Line Out	Front Speaker Out	Front Speaker Out	Front Speaker Out
C	Orange (Center/Subwoofer)			Center/ Subwoofer	Center/ Subwoofer
D	Black (Surround)		Rear Speaker Out	Rear Speaker Out	Rear Speaker Out
E	Pink (Mic In)	Mic In	Mic In	Mic In	Mic In

- A. Line In
- B. Line Out
- C. Center/LFE Out
- D. Surround Out
- E. Mic In



### ATX PS/2 Keyboard/Mouse Port

The ATX PS/2 keyboard and PS/2 mouse port is located on the back panel above USB 2/3.

### DisplayPort Ports

DisplayPort, developed by the VESA consortium, delivers digital display at a fast refresh rate. It can connect to virtually any display device using a DisplayPort adapter for devices, such as VGA, DVI, and HDMI.

### HDMI Port

One HDMI 2.0a (High-Definition Multimedia Interface) port is located on the I/O back panel. This port is used to display both high definition video and digital sound through an HDMI capable display, using a single HDMI cable (not included).

### LAN Ports

Two RJ45 Ethernet LAN ports (LAN1/LAN2) are located on the I/O back panel. These ports accept RJ45 type cables.



**Note:** Please refer to Section 2-9 for LAN LED information.

LAN Ports Pin Definitions					
Pin#	Definition	Pin#	Definition	Pin	Definition
1	P2V5SB	7	TD2-	13	Link 100 LED (Green, +3V3SB)
2	TD0+	8	TD3+	14	Link 1000 LED (Yellow, +3V3SB)
3	TD0-	9	TD3-	15	Ground
4	TD1+	10	SGND	16	Ground
5	TD1-	11	Act LED	17	Ground
6	TD2+	12	P3V3SB	18	Ground

- A. PS/2 Keyboard/Mouse Port
- B. DisplayPort Port 1
- C. DisplayPort Port 2
- D. LAN1
- E. LAN2
- F. HDMI Port

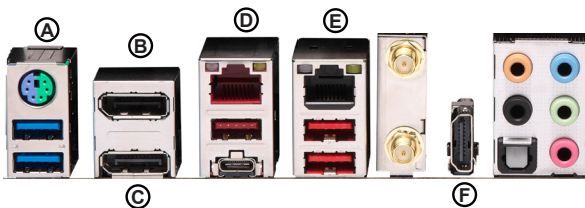

## Front Control Panel

JF1 contains header pins for various buttons and indicators that are normally located on a control panel at the front of the chassis. These connectors are designed specifically for use with Supermicro chassis. See the figure below for the descriptions of the front control panel buttons and LED indicators. Refer to the following section for descriptions and pin definitions.

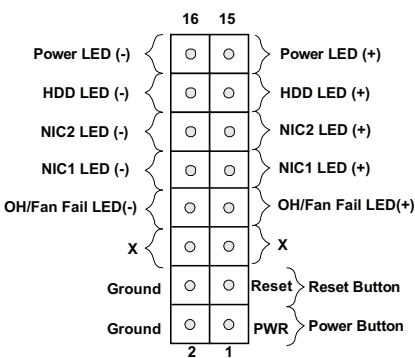
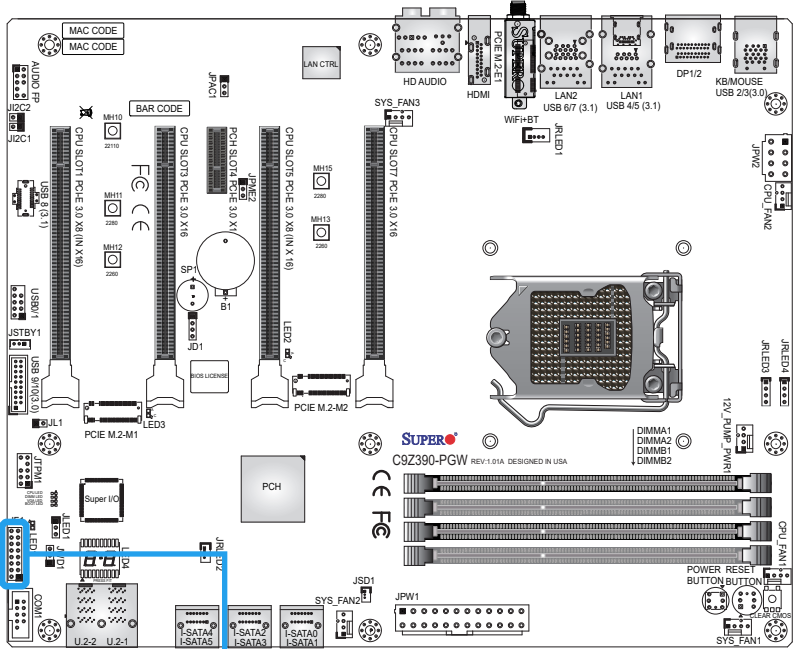

### JF1 Header Pins

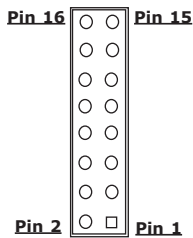

## Front Control Panel Pin Definitions

### Power LED

The Power LED connection is located on pins 15 and 16 of JF1. Refer to the table on the right for pin definitions.

Power LED Pin Definitions (JF1)	
Pin#	Definition
15	+5V
16	Vcc

### HDD LED

The HDD LED connection is located on pins 13 and 14 of JF1. Attach a cable here to indicate the status of HDD-related activities, including IDE and SATA activities. Refer to the table on the right for pin definitions.

HDD LED Pin Definitions (JF1)	
Pin#	Definition
13	Vcc
14	HDD LED

### NIC1/NIC2 (LAN1/LAN2) LED

The NIC (Network Interface Controller) LED connection for LAN1/LAN2 is located on pins 9/11 and 10/12 of JF1. Attach an LED indicator to this header to display network activity. Refer to the table on the right for pin definitions.

NIC1/NIC2 LED Pin Definitions (JF1)	
Pin#	Definition
9/11	Vcc
10/12	NIC1/NIC2 LED

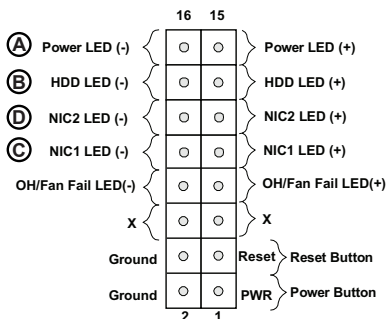

- A. Power LED
- B. HDD LED
- C. NIC1 LED
- D. NIC2 LED

### Reset Button

The Reset Button connection is located on pins 3 and 4 of JF1. Attach it to a hardware reset switch on the computer case to reset the system. Refer to the table on the right for pin definitions.

Reset Button Pin Definitions (JF1)	
Pin#	Definition
3	Reset Button
4	Ground

### Power Button

The Power Button connection is located on pins 1 and 2 of JF1. Momentarily contacting both pins will power on/off the system. To turn off the power in the suspend mode, press the button for at least four seconds. Refer to the table on the right for pin definitions.

Power Button Pin Definitions (JF1)	
Pin#	Definition
1	Power Button
2	Ground

### Overheat (OH)/Fan Fail LED

Connect an LED cable to OH/Fan Fail connections on pins 7 and 8 of JF1 to provide warnings for chassis overheat/fan failure. Refer to the tables on the right for more information.

OH/Fan Fail LED Pin Definitions (JF1)	
Pin#	Definition
7	Vcc
8	OH/Fan Fail LED

OH/Fan Fail Indicator Status	
State	Definition
Off	Normal
On	Overheat
Flashing	Fan Fail

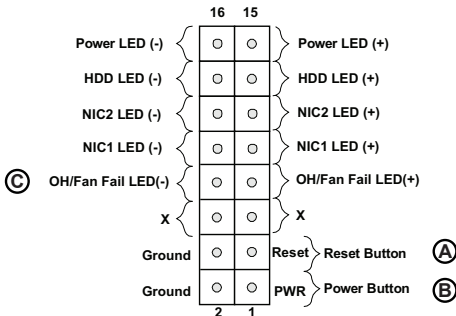

- A. Reset Button
- B. PWR Button
- C. OH/Fan Fail LED

## 2-7 Connecting Cables

This section provides brief descriptions and pinout definitions for onboard headers and connectors. Be sure to use the correct cable for each header or connector.

### ATX Main PWR & CPU PWR Connectors

The 24-pin main power connector (JPW1) is used to provide power for the motherboard. The 8-pin CPU PWR connector (JPW2) is also required for the processor. These power connectors meet the SSI EPS 12V specification. Refer to the tables on the right for pin definitions.

ATX Power 24-pin Connector Pin Definitions			
Pin#	Definition	Pin#	Definition
13	+3.3V	1	+3.3V
14	-12V	2	+3.3V
15	Ground	3	Ground
16	PS_ON	4	+5V
17	Ground	5	Ground
18	Ground	6	+5V
19	Ground	7	Ground
20	Res (NC)	8	PWR_OK
21	+5V	9	5VSB
22	+5V	10	+12V
23	+5V	11	+12V
24	Ground	12	+3.3V

- A. 24-Pin ATX Main PWR Connector
- B. 8-Pin PWR Connector

8-pin Power Connector Pin Definitions	
Pins	Definition
1-4	Ground
5-8	+12V

(Required)

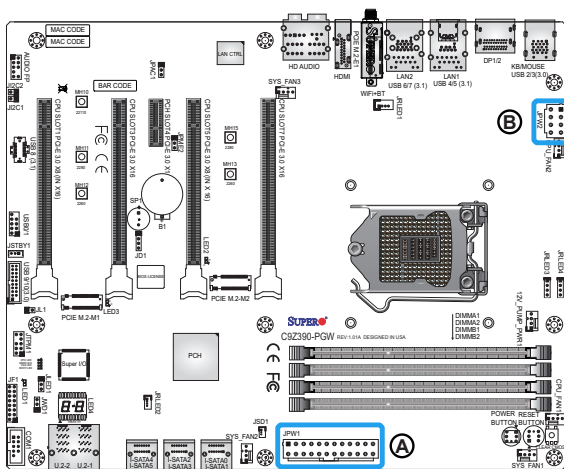

### Fan Headers

The motherboard has five fan headers. These fans are 4-pin fan headers. Although Pins 1-3 of the system fan headers are backwards compatible with the traditional 3-pin fans, the 4-pin fans are recommended to take advantage of the fan speed control. This allows fan speeds to be automatically adjusted based on the motherboard temperature. Refer to the table on the right for pin definitions.

Fan Headers Pin Definitions	
Pin#	Definition
1	Ground (Black)
2	2A/+12V (Red)
3	Tachometer
4	PWM_Control

### Chassis Intrusion Header

A Chassis Intrusion header is located at JL1 on the motherboard. Attach the appropriate cable from the chassis to inform you of a chassis intrusion when the chassis is opened.

Chassis Intrusion Header Pin Definitions	
Pin#	Definition
1	Intrusion Input
2	Ground

- A. CPU\_FAN1
- B. CPU\_FAN2
- C. SYS\_FAN2
- D. SYS\_FAN1
- E. SYS\_FAN3
- F. Chassis Intrusion Header

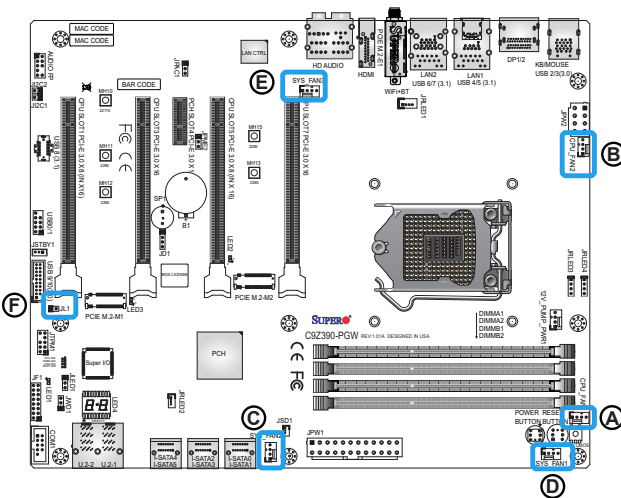

### Speaker Header

On JD1 Header, pins 3 and 4 are used for the internal speaker. Close pins 3 and 4 with a cap to use the onboard speaker. If you wish to use an external speaker, close pins 1-4 with a cable. Refer to the table on the right for pin definitions.

Speaker Header Pin Definitions	
Pin Setting	Definition
Pins 3-4	Internal Speaker
Pins 1-4	External Speaker

### Pump Power Header

The C9Z390-PGW has one +12V header for optional CPU liquid cooling systems. When using a liquid cooling system, attach the pump power cable to the 12V\_PUMP header.

Pump Power Header Pin Definitions	
Pin	Definition
1	Ground (Black)
2	2A/+12V (Red)
3	N/A
4	N/A

A. Speaker Header

B. Pump Power Header

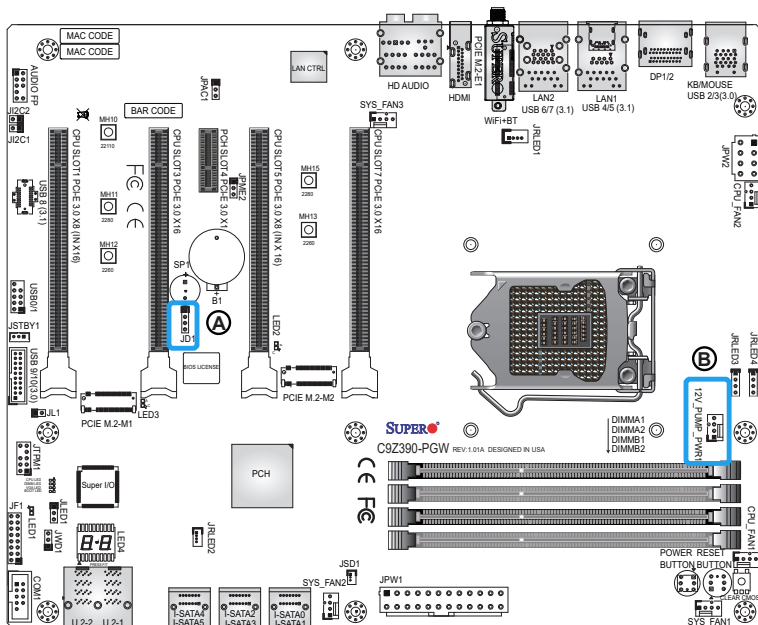

### Power LED Header

An onboard Power LED header is located at JLED1. This Power LED header is connected to Front Control Panel located at JF1 to indicate the status of system power. Refer to the table on the right for pin definitions.

Power LED Header Pin Definitions	
Pin#	Definition
1	VCC
2	No Connection
3	Connection to PWR LED in JF1

### Serial (COM) Header

There is one serial (COM) header on the motherboard. COM1 is located below the JF1 header. Refer to the table on the right for pin definitions.

Serial (COM) Header Pin Definitions			
Pin#	Definition	Pin#	Definition
1	DCD	6	DSR
2	RXD	7	RTS
3	TXD	8	CTS
4	DTR	9	RI
5	Ground	10	N/A

A. Power LED Header

B. COM1

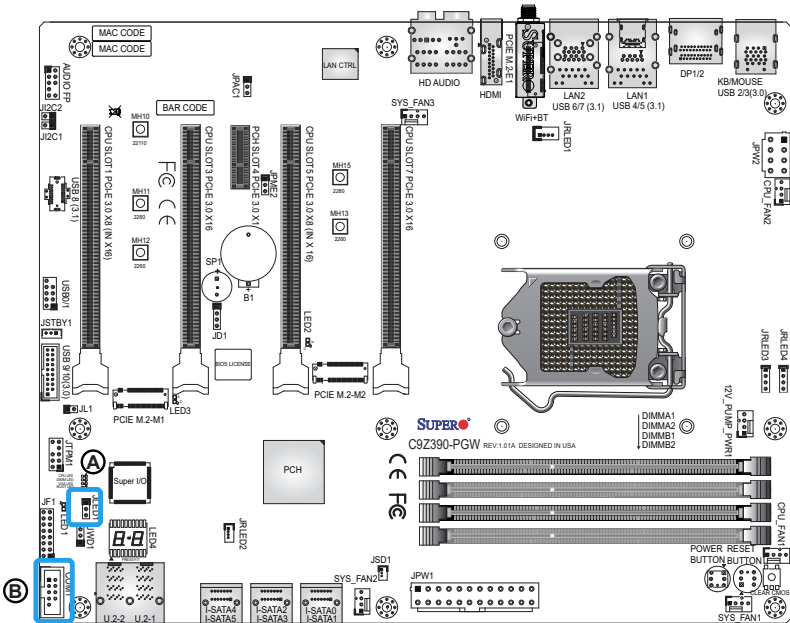

### DOM PWR Connector

The Disk-On-Module (DOM) power connector, located at JSD1, provides 5V power to a solid state DOM storage device connected to one of the SATA ports. Refer to the table on the right for pin definitions.

DOM PWR Connector Pin Definitions	
Pin#	Definition
1	5V
2	Ground
3	Ground

A. DOM PWR Connector

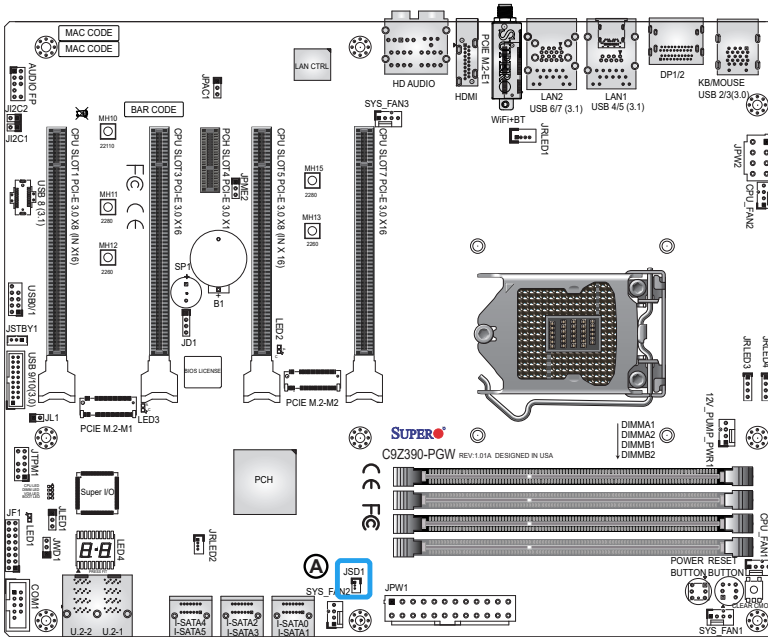

## Standby Power Header

The Standby Power header is located at JSTBY1 on the motherboard. Refer to the table on the right for pin definitions.

Standby Power Header Pin Definitions	
Pin#	Definition
1	+5V Standby
2	Ground
3	Wake-up

## M.2 Connectors

M.2 connectors are designed for devices such as memory cards, wireless adapters, etc. These devices must conform to the PCI-E M.2 specifications (formerly known as NGFF).



**Note:** PCI-E M.2-M1 port shares lanes with U.2-1 port. PCI-E M.2-M2 port shares lanes with I-SATA4 and I-SATA5.

**Note:** PCI-E M.2-M1 and PCI-E M.2-M2 support RAID 0 and RAID 5.

- A. Standby Power Header
- B. PCI-E M.2-M1
- C. PCI-E M.2-M2
- D. PCI-E M.2-E1

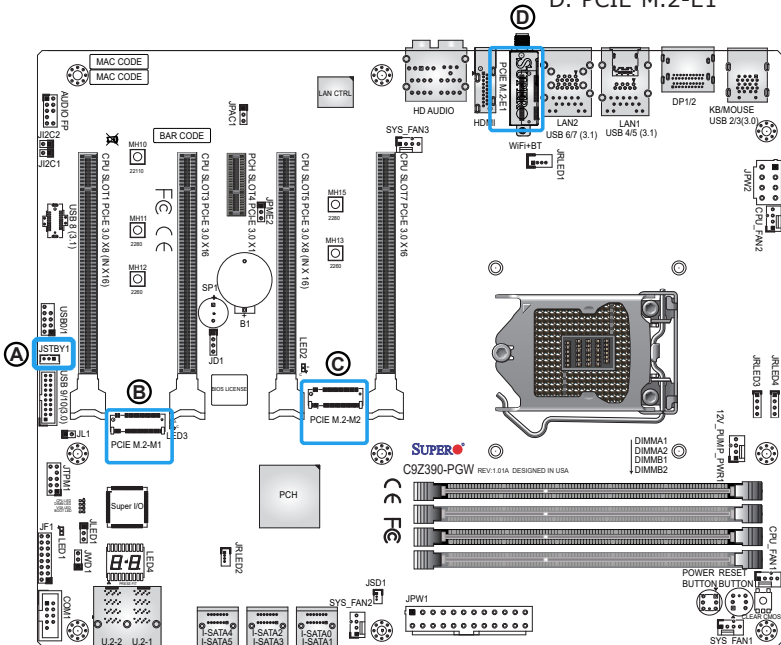



## Battery Connector

B1 is a two-pin connector for an external CMOS battery. This connector is also used to clear the CMOS. To clear the CMOS, remove the battery, short pins 1 and 2 and then install the battery.

## TPM/Port 80 Header

A Trusted Platform Module/Port 80 header is located at JTPM1 to provide TPM support and Port 80 connection. Use this header to enhance system performance and data security. Refer to the table on the right for pin definitions.

TPM/Port 80 Header Pin Definitions			
Pin#	Definition	Pin#	Definition
1	P3V3	2	SPI_TPM_CS_N
3	PCIE_RESET_N	4	SPI_PCB_MISO
5	SPI_PCH_CLK	6	GND
7	SPI_PCH_MOSI	8	X
9	P3V3_STBY	10	IRQ_TPM_SPI_N

A. Battery Connector

B. TPM/Port 80 Header

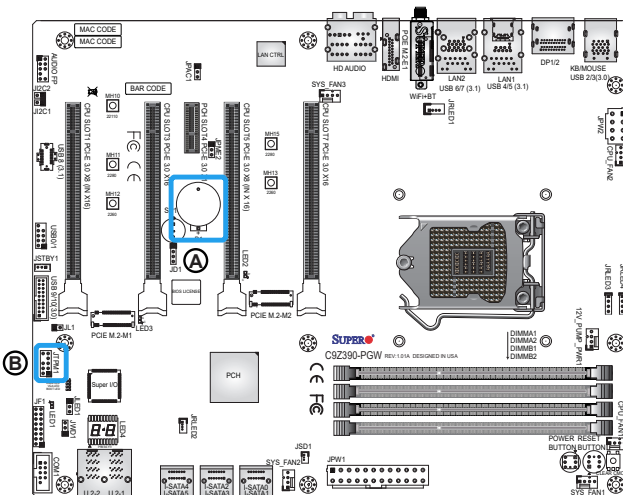

## 2-8 Jumper Settings

### Explanation of Jumpers

To modify the operation of the motherboard, jumpers can be used to choose between optional settings. Jumpers create shorts between two pins to change the function of the connector. Pin 1 is identified with a square solder pad on the printed circuit board.



**Note:** On two-pin jumpers, "Closed" means the jumper is on, and "Open" means the jumper is off the pins.

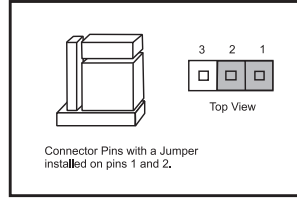
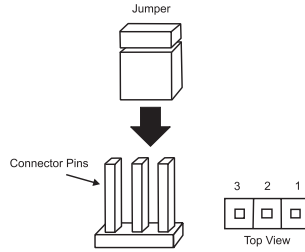

## Clear CMOS Button

Clear CMOS Button is used to clear the saved system setup configuration stored in the CMOS chip. Clearing BIOS works the same way but is a push button switch. This will erase all user settings and revert everything to their factory-set defaults.

## PCI Slot SMB Jumpers

Use Jumpers JI2C1 and JI2C2 to enable PCI SMB (System Management Bus) support to improve system management for the PCI slots. See the table on the right for jumper settings.

PCI Slot SMB Jumpers Settings	
Jumper Setting	Definition
Short	Enabled
Open (Default)	Disabled

- A. JI2C1
- B. JI2C2
- C. Clear CMOS Button

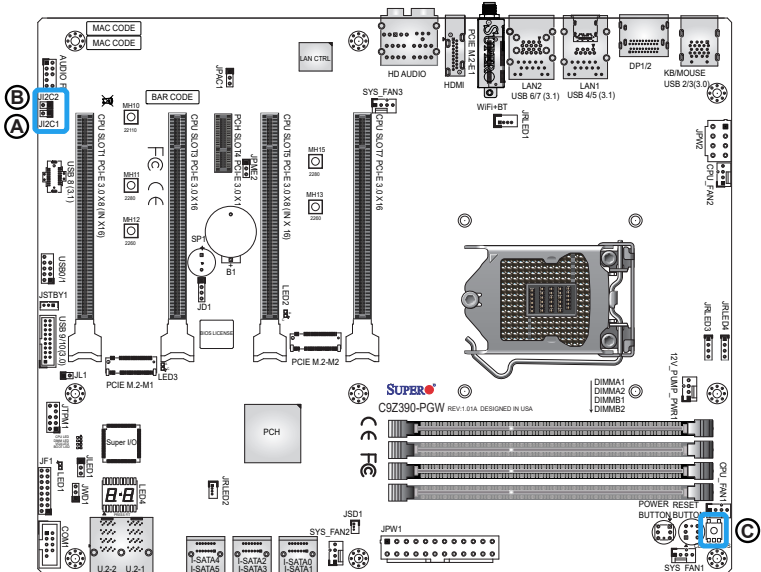

### Manufacturing Mode

Close pins 2 and 3 of Jumper JPME2 to bypass SPI flash security and force the system to operate in Manufacturing Mode, allowing the user to flash the system firmware from a host server for system setting modifications. Refer to the table on the right for jumper settings.

Manufacture Mode Jumper Settings	
Pin#	Definition
1-2	Normal (Default)
2-3	Manufacture Mode

### Audio Enable/Disable Jumper

JPAC1 allows you to enable or disable the onboard audio support. The default position is on pins 1 and 2 to enable onboard audio connections. Refer to the table on the right for jumper settings.

Audio Enable/Disable Jumper Settings	
Jumper Setting	Definition
Pins 1-2	Enabled (Default)
Pins 2-3	Disabled

### Watch Dog

Watch Dog (JWD1) is a system monitor that can reboot the system when a software application hangs. Close pins 1 and 2 to reset the system if an application hangs. Close pins 2 and 3 to generate a non-maskable interrupt signal for the application that hangs. Refer to the table on the right for jumper settings.

Watch Dog Jumper Settings	
Jumper Setting	Definition
Pins 1-2	Reset (Default)
Pins 2-3	NMI
Open	Disabled

- A. Manufacturing Mode
- B. Audio Enable/Disable Jumper
- C. Watch Dog

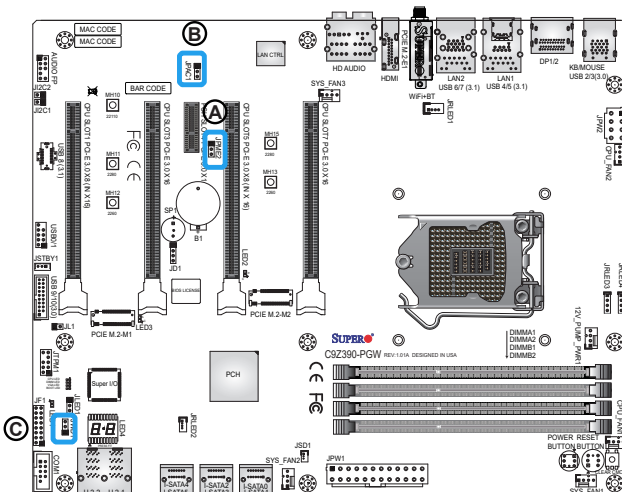



## 2-9 Onboard Indicators

### LAN LEDs

Two LAN ports are located on the I/O back panel of the motherboard. This Ethernet LAN port has two LEDs (Light Emitting Diode). The yellow LED indicates activity, while the Link LED may be green, amber, or off to indicate the speed of the connections. Refer to the tables on the right and below for more information.

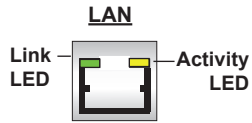

1G/10G LAN Activity Indicator LED Settings		
Color	Status	Definition
Yellow	Flashing	Active

1G LAN Link Indicator LED Settings	
LED Color	Definition
Off	No Connection
Amber	100Mbps/10Mbps
Green	1 Gbps.

10G LAN Link Indicator LED Settings	
LED Color	Definition
Off	No Connection
Amber	5Gbps/2.5Gbps/1Gbps/100Mbps
Green	10 Gbps.

### Power LED

An Onboard Power LED is located at LED1 on the motherboard. When LED1 is on, the AC power cable is connected. Make sure to disconnect the power cable before removing or installing any component. See the layout below for the LED location.

Power LED Indicator LED Status	
Status	Definition
Off	System Off
On	System on, or System off and PWR Cable Connected

- A. LAN1 LEDs
- B. LAN2 LEDs
- C. Power LED

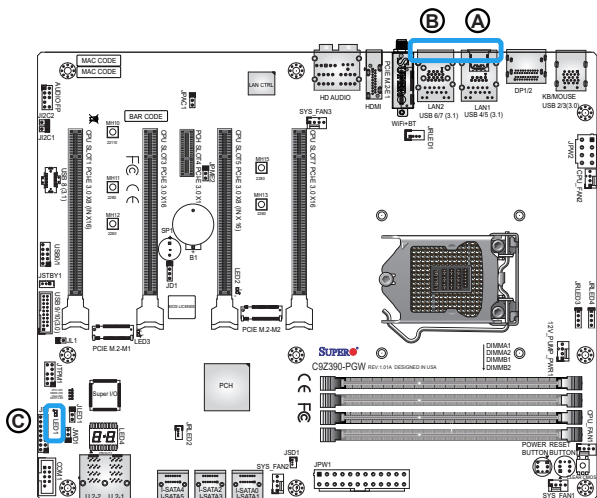

## Status Code LED

LED4 is made up of two alpha-numeric displays that will display a status or POST code, when the motherboard is powered on. Please download the following AMI publication for a complete list of POST codes:

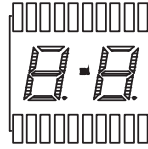

[https://www.supermicro.com/manuals/other/AMI\\_AptioV\\_BIOS\\_POST\\_Codes\\_for\\_SM\\_Motherboards.pdf](https://www.supermicro.com/manuals/other/AMI_AptioV_BIOS_POST_Codes_for_SM_Motherboards.pdf)

### A. Status Code LED

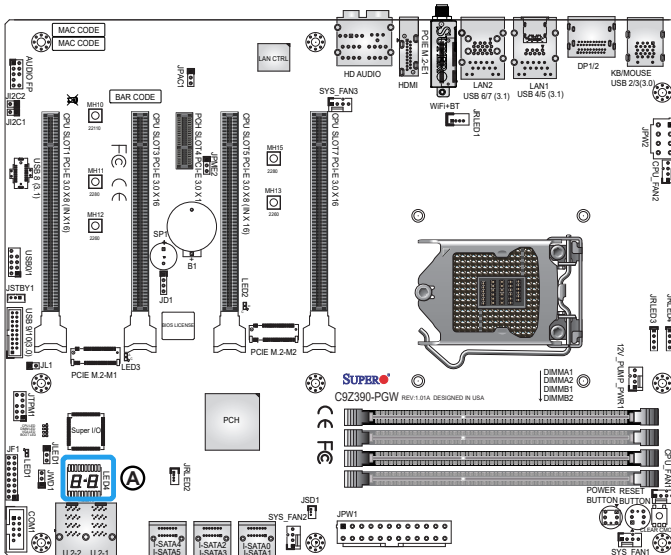

## 2-10 Hard Drive Connections

### SATA Connections

Six Serial ATA (SATA) 3.0 connectors (I-SATA 0~5) are supported on the motherboard. These I-SATA 3.0 ports are supported by the Intel Z390 PCH chip (supports RAID 0, 1, 5, and 10). Refer to the table on the right for pin definitions.

SATA 3.0 Connectors Pin Definitions	
Pin#	Signal
1	Ground
2	SATA_TXP
3	SATA_TXN
4	Ground
5	SATA_RXN
6	SATA_RXP
7	Ground

### U.2 SSD Connectors

U.2 SSD Connectors (U.2-1, U.2-2) are supported on the motherboard. These connectors support Solid State Drives (SSD) and is an extension of the existing SATA connectors. They offer up to PCI-E 3.0 x4 lanes to a connected SSD device.



**Note:** U.2-1 port shares lanes with M.2-M1 port. U.2-1 and U.2-2 support RAID 0 and RAID 5.

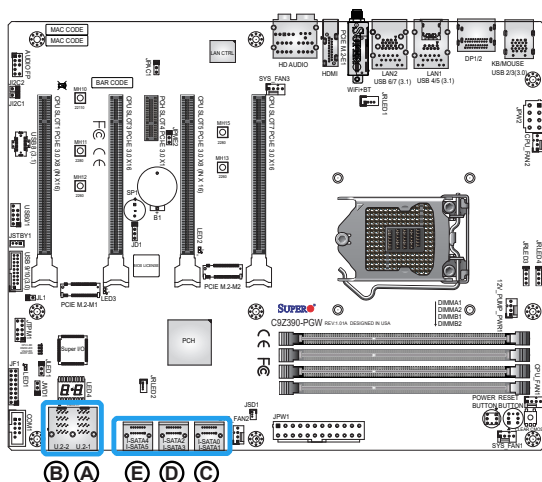

- A. U.2-1
- B. U.2-2
- C. I-SATA0/I-SATA1
- D. I-SATA2/I-SATA3
- E. I-SATA4/I-SATA5

---

---

## Chapter 3

### Troubleshooting

#### 3-1 Troubleshooting Procedures

Use the following procedures to troubleshoot your system. If you have followed all of the procedures below and still need assistance, refer to the 'Technical Support Procedures' and/or 'Returning Merchandise for Service' section(s) in this chapter. Always disconnect the AC power cord before adding, changing or installing any hardware components.

##### Before Power On

1. Make sure that the Standby PWR LED is not on. (**Note:** If it is on, the onboard power is on. Be sure to unplug the power cable before installing or removing the components.)
2. Make sure that there are no short circuits between the motherboard and chassis.
3. Disconnect all ribbon/wire cables from the motherboard, including those for the keyboard and mouse. Also, be sure to remove all add-on cards.
4. Install a CPU and heatsink (be sure that it is fully seated) and then connect the chassis speaker and the power LED to the motherboard. Check all jumper settings as well.

##### No Power

1. Make sure that there are no short circuits between the motherboard and chassis.
2. Make sure that all jumpers are set to their default positions.
3. Check if the 115V/230V switch on the power supply is properly set.
4. Turn the power switch on and off to test the system.
5. The battery on your motherboard may be old. Check to make sure that it still supplies ~3VDC. If it does not, replace it.

## No Video

1. If the power is on, but you have no video--in this case, you will need to remove all the add-on cards and cables first.
2. Use the speaker to determine if any beep codes exist. (Refer to Appendix A for details on beep codes.)
3. Remove all memory modules and turn on the system. (If the alarm is on, check the specifications of memory modules, reset the memory or try a different one.)

## Memory Errors

1. Make sure that the DIMM modules are properly installed and fully seated in the slots.
2. You should be using unbuffered Non-ECC DDR4 (up to 4000+ MHz with OC) memory recommended by the manufacturer. Also, it is recommended that you use the memory modules of the same type and speed for all DIMMs in the system. Do not use memory modules of different sizes, different speeds and different types on the same motherboard.
3. Check for bad DIMM modules or slots by swapping modules between slots to see if you can locate the faulty ones.
4. Check the switch of 115V/230V power supply.

## When the System is Losing the Setup Configuration

1. Please be sure to use a high quality power supply. A poor quality power supply may cause the system to lose CMOS setup information. Refer to Section 1-7 for details on recommended power supplies.
2. The battery on your motherboard may be old. Check to verify that it still supplies ~3VDC. If it does not, replace it with a new one.
3. If the above steps do not fix the Setup Configuration problem, contact your vendor for repairs.

## 3-2 Technical Support Procedures

Before contacting Technical Support, please make sure that you have followed all the steps listed below. Also, note that as a motherboard manufacturer, Supermicro does not sell directly to end users, so it is best to first check with your distributor or reseller for troubleshooting services. They should know of any possible problem(s) with the specific system configuration that was sold to you.

1. Please go through the 'Troubleshooting Procedures' and 'Frequently Asked Question' (FAQ) sections in this chapter or see the FAQs on our website (<http://www.supermicro.com/support/faqs/>) before contacting Technical Support.
2. BIOS upgrades can be downloaded from our website at (<http://www.supermicro.com/support/bios/>).



**Note:** Not all BIOS can be flashed. Some cannot be flashed; it depends on the boot block code of the BIOS.

3. If you've followed the instructions above to troubleshoot your system, and still cannot resolve the problem, then contact Supermicro's technical support and provide them with the following information:
  - Motherboard model and PCB revision number
  - BIOS release date/version (this can be seen on the initial display when your system first boots up)
  - System configuration
  - An example of a Technical Support form is on our website at (<http://www.supermicro.com/support/contact.cfm>).
4. Distributors: For immediate assistance, please have your account number ready when placing a call to our technical support department. We can be reached by e-mail at [support@supermicro.com](mailto:support@supermicro.com), by phone at: (408) 503-8000, option 2, or by fax at (408)503-8019.

### 3-3 Frequently Asked Questions

**Question:** What type of memory does my motherboard support?

**Answer:** Supports up to 128GB (available only for selected 9th Gen processors) of unbuffered, non-ECC, 4000+ MHz (OC) DDR4 memory. See Section 2-4 for details on installing memory.

**Question:** How do I update my BIOS?

**Answer:** We do NOT recommend that you upgrade your BIOS if you are not experiencing any problems with your system. Updated BIOS files are located on our website at <http://www.supermicro.com/support/bios/>. Please check our BIOS warning message and the information on how to update your BIOS on our web site. Select your motherboard model and download the BIOS ROM file to your computer. Also, check the current BIOS revision to make sure that it is newer than your BIOS before downloading. You may choose the zip file or the .exe file. If you choose the zipped BIOS file, please unzip the BIOS file onto a bootable device or a USB pen/thumb drive. To flash the BIOS, run the batch file named "ami.bat" with the new BIOS ROM file from your bootable device or USB pen/thumb drive. Use the following format:

```
F:\> ami.bat BIOS-ROM-filename.xxx <Enter>
```



**Note:** Always use the file named "ami.bat" to update the BIOS, and insert a space between "ami.bat" and the filename. The BIOS-ROM-filename will bear the motherboard name (i.e., C9Z390-PGW) and build version as the extension. For example, "C7Z390-PGW.115". When completed, your system will automatically reboot.

If you choose the .exe file, please run the .exe file under Windows to create the BIOS flash floppy disk. Insert the floppy disk into the system you wish to flash the BIOS. Then, boot the system to the floppy disk. The BIOS utility will automatically flash the BIOS without any prompts. Please note that this process may take a few minutes to complete. Do not be concerned if the screen is paused for a few minutes.

When the BIOS flashing screen is completed, the system will reboot and will show "Press F1 or F2". At this point, you will need to load the BIOS defaults. Press <F1> to go to the BIOS setup screen, and press <F9> to load the default settings. Next, press <F10> to save and exit. The system will then reboot.



**Attention!** Do not shut down or reset the system while updating the BIOS to prevent possible system boot failure!

**Question:** I think my BIOS is corrupted. How can I recover my BIOS?

**Answer:** Please see Appendix C-BIOS Recovery for detailed instructions.

## 3-4 Battery Removal and Installation

### Battery Removal

To remove the onboard battery, follow the steps below:

1. Power off your system and unplug your power cable.
2. Locate the onboard battery as shown below.
3. Using a tool such as a pen or a small screwdriver, push the battery lock outwards to unlock it. Once unlocked, the battery will pop out from the holder.
4. Remove the battery.

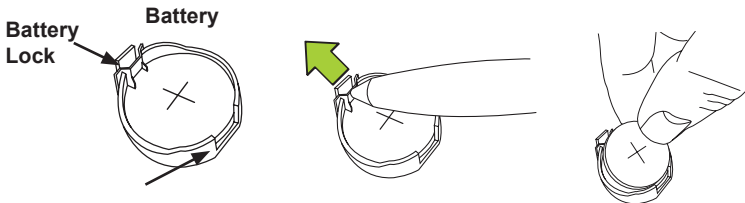

### Proper Battery Disposal

- ! **Attention!** Please handle used batteries carefully. Do not damage the battery in any way; a damaged battery may release hazardous materials into the environment. Do not discard a used battery in the garbage or a public landfill. Please comply with the regulations set up by your local hazardous waste management agency to dispose of your used battery properly.

## Battery Installation

1. To install an onboard battery, follow steps 1 and 2 above and continue below:
2. Identify the battery's polarity. The positive (+) side should be facing up.
3. Insert the battery into the battery holder and push it down until you hear a click to ensure that the battery is securely locked.

**!** **Attention!** When replacing a battery, be sure to only replace it with the same type.

### Battery Holder

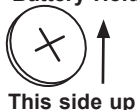

## 3-5 Returning Motherboard for Service

A receipt or copy of your invoice marked with the date of purchase is required before any warranty service will be rendered. You can obtain service by calling your vendor for a Returned Merchandise Authorization (RMA) number. For faster service, you may also obtain RMA authorizations online (<http://www.supermicro.com/RmaForm/>). When you return the motherboard to the manufacturer, the RMA number should be prominently displayed on the outside of the shipping carton, and mailed prepaid or hand-carried. Shipping and handling charges will be applied for all orders that must be mailed when service is complete.

This warranty only covers normal consumer use and does not cover damages incurred in shipping or from failure due to the alteration, misuse, abuse or improper maintenance of products.

During the warranty period, contact your distributor first for any product problems.

# Chapter 4

## UEFI BIOS

### 4-1 Introduction

This chapter describes the AMI BIOS Setup Utility for the C9Z390-PGW. The ROM BIOS is stored in a Flash EEPROM and can be easily updated. This chapter describes the basic navigation of the AMI BIOS Setup Utility setup screens.



**Note:** For AMI BIOS Recovery, please refer to the UEFI BIOS Recovery Instructions in Appendix C.

### Starting BIOS GUI Setup Utility

To enter the AMI BIOS GUI Setup Utility screens, press the <Delete> key while the system is booting up.



**Note:** In most cases, the <Delete> key is used to invoke the AMI BIOS setup screen.

Each BIOS menu option is described in this manual. The Advanced Mode BIOS Setup screen has two main areas. The top area is the main Navigation, and the bottom area is for the Information Section. Icons that do not respond when the mouse pointer is hovering on top are not configurable.

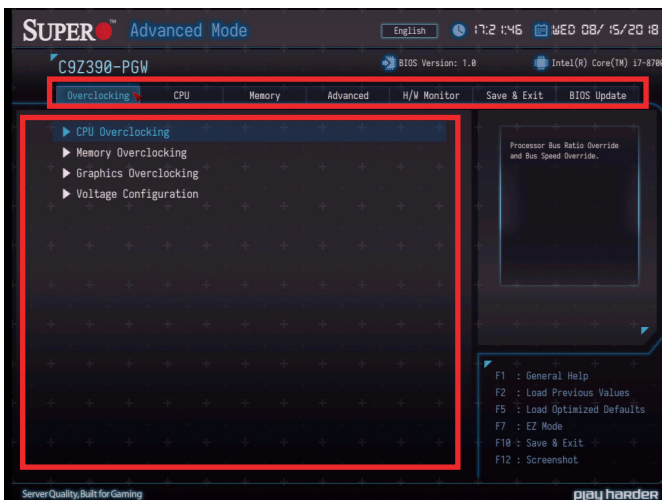

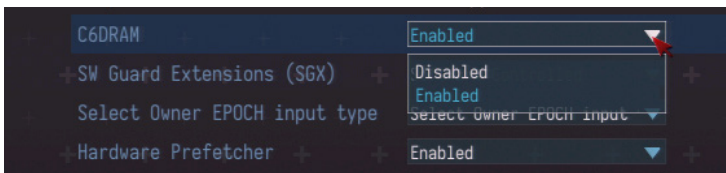

The AMI BIOS GUI Setup Utility uses a mouse pointer navigation system similar to standard graphical user interfaces. Hover and click an icon to select a section, click a down arrow to select from an options list.

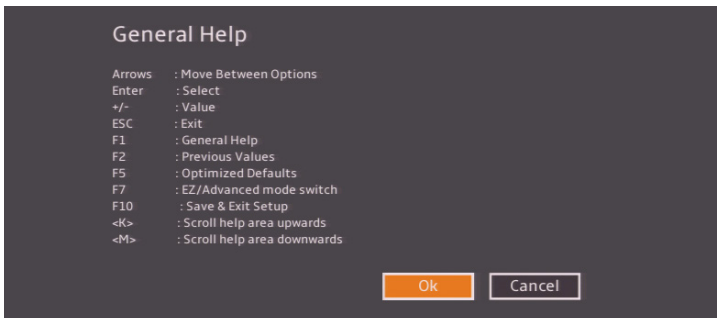

You may press the <F1> on any screen under the Setup Section to see a list of Hot Keys that are available. Press <F12> to print the screen.

The keyboard's Escape key <ESC> cancels the current screen and will return you back to the previous screen.

### Changing Between EZ Mode and Advanced Mode

To change between EZ Mode and Advanced Mode, hit F7 on the keyboard. When in EZ Mode, select feature options and an overview of hardware status are displayed (see Section 4-2). When in Advanced Mode, all following configuration menus and their contents become available.

## 4-2 EZ Mode



While in EZ Mode, the following information will be displayed:

**BIOS Version** - The current BIOS version

**CPU Information** - The model, speed, and voltage of installed CPU

**Memory Frequency** - The frequency of installed memory

**System Temp** - Displays CPU and PCH temperatures

**CPU Profile** - Allows changing of the CPU profile by clicking the left or right arrows

**DRAM Status** - Status of all DIMM slots

**SATA Info** - Displays which SATA ports are connected to storage devices

**Boot Priority** - Allows changing of the boot order, or click a device to boot selected device



**Note:** Using this will reboot the computer.

**X.M.P.** - Allows changing the X.M.P. profile

**Intel Rapid Storage Technology** - Allows for enabling Intel Rapid Storage Technology

**Fan Profile** - Displays current fan speeds

## 4-3 Overclocking

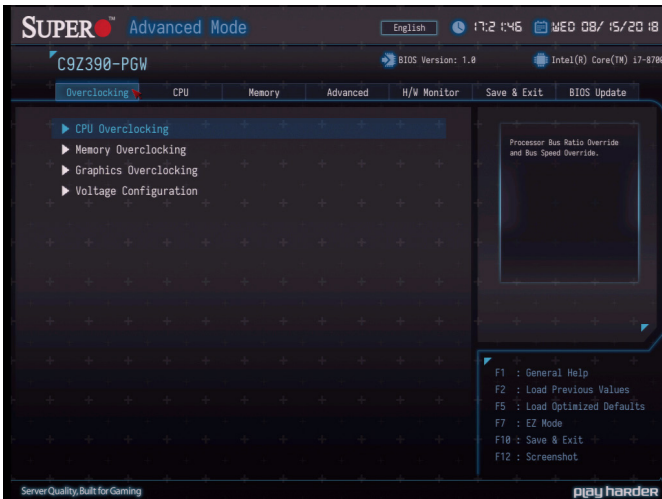

### ► CPU Overclocking

#### CPU Profile

This feature allows for preset CPU overclocking profiles to be selected. The options are Stable, **Default**, and Performance.

#### Advanced CPU OC Setting

This feature controls the CPU overclocking settings. The options are **Manual**, 4.3GHz, 4.4GHz, 4.5GHz, 4.6GHz, 4.7GHz, 4.8GHz, 4.9GHz, 5.0GHz, 5.1GHz, 5.2GHz, 5.3GHz, 5.4GHz, and 5.5GHz.

#### 1-Core ~ 8-Core Ratio Limit Override

Enter a value for each individual CPU core.

#### Active Processor Cores

Use this feature to select the number of active processor cores. The default option is **All**. These options depend on how many cores are supported by the CPU.

#### BCLK Clock Frequency(1/100 MHz)

Enter a value for the BCLK frequency. The default is **10000**.

### **FCLK Frequency for Early Power On**

Select the FCLK frequency for early power on. The options are Normal (800MHz), 1GHz, 400MHz, and **Auto**.

### **BCLK Aware Adaptive Voltage**

This feature enables BCLK Aware Adaptive Voltage, which helps avoid high voltage overrides by forcing pcode to be aware of the BCLK frequency when making calculations. The options are Disabled and **Enabled**.

### **Core Max OC Ratio**

This feature controls the general maximum overclocking ratio for the CPU cores and Ring. The default is **43**.

### **AVX Ratio Offset**

Enter a value for AVX Ratio Offset. The default is **0**.

### **TjMax Offset**

Enter a value to change the Tj-Max value. The default is **0**.

### **Power Limit 1 Override**

This feature enables Power Limit 1 override. If set to Disabled, the BIOS will program a default power limit and power limit time window. If set to Enabled, the following two features become available. The options are **Disabled** and Enabled.

#### **Power Limit 1**

Enter a value for Power Limit 1. The default is **95000**.

#### **Power Limit 1 Time Window**

This feature controls the time window for Power Limit 1. The default is **8**.

#### **Power Limit 2 Override**

This feature enables Power Limit 2 override. If set to Disabled, the BIOS will program a default power limit and power limit time window. The options are Disabled and **Enabled**.

#### **Power Limit 2**

Enter a value for Power Limit 2. The default is **113750**.

### **TVB Ratio Clipping**

This feature enables CPU core frequency reduction for processors that implement Intel Thermal Velocity Boost (TVB). For overclocking, this feature *must* be **Disabled**.

---

## TVB Voltage Optimizations

This feature enables thermal base voltage optimizations for processors that implement Intel Thermal Velocity Boost (TVB). The options are Disabled and **Enabled**.

### ► CPU feature

#### Hyper-Threading

This feature enables hyper-threading, which is a software method to control logical processor threads. The options are Disabled and **Enabled**.

#### Boot Performance Mode

This feature controls the performance state that the BIOS will set initially. The options are **Max Non-Turbo Performance** and Turbo Performance.

#### Intel(R) SpeedStep(tm)

Intel SpeedStep Technology allows the system to automatically adjust processor voltage and core frequency in an effort to reduce power consumption and heat dissipation. **Please refer to Intel's website for detailed information.** The options are Disabled and **Enabled**.

#### Race To Halt (RTH)

This feature enables Race To Halt, which dynamically increases CPU frequency in order to enter package C-State faster. This will reduce overall power consumption. The options are Disabled and **Enabled**.

#### Intel(R) Speed Shift Technology

This feature enables Intel Speed Shift, which allows the operating system to hand control of CPU frequency and voltage to the processor. This increases P-state change speed and improves power efficiency. The options are Disabled and **Enabled**.

#### C states

C-State architecture, a processor power management platform developed by Intel, can further reduce power consumption from the basic C1 (Halt State) state that blocks clock cycles to the CPU. Select Enabled for CPU C-State support. The options are Disabled and **Enabled**.

## Thermal Monitor

This feature enables the CPU thermal monitor. The options are Disabled and **Enabled**.

### ►Ring

#### Ring Max OC Ratio

Enter a value for the maximum overclock ratio for CPU Ring. The default is **0**.

#### Ring Down Bin

This feature enables Ring Down Bin. If set to Enabled, the maximum ring ratio will not be observed. The options are Disabled and **Enabled**.

#### Min Ring Ratio Limit

Enter a value for the minimum ratio limit for CPU Ring. The default is **0**.

#### Max Ring Ratio Limit

Enter a value for the maximum ratio limit for CPU Ring. The default is **0**.

### ►CPU VR Settings

#### VR Power Delivery Design

This feature is intended for motherboard validation purposes. The specifies the CFL-S board design for VR settings override values. The default is **Auto**.

#### PSYS Slope

Enter a value for the PSYS Slope. The range is 0-200. The default is **0**.

#### PSYS Offset

Enter a value for the PSYS Offset. The range is 0-255. The default is **0**.

---

## PSYS PMax Power

Enter a value for the PSYS PMax Power. The range is 0-8192. The default is **0**.

### ► Acoustic Noise Settings

#### Acoustic Noise Mitigation

This feature enables Acoustic Noise Mitigation, which mitigates acoustic noise on certain CPUs when they are in deep C-states. If set to Enabled, the following features may be configured:

#### Pre-Wake Time

#### Ramp Up Time

#### Ramp Down Time

Enter a value for the desired feature. The range is 0-255. The default is **0**.

#### Disable Fast PKG C State Ramp for IA Domain

#### Disable Fast PKG C State Ramp for GT Domain

#### Disable Fast PKG C State Ramp for SA Domain

#### Disable Fast PKG C State Ramp for VccIn Domain

This feature disables fast package C-state ramping in a specific domain. If set to FALSE, the selected domain will continue to fast ramp. If set to TRUE, the selected domain will disable fast ramping. The options are TRUE and **FALSE**.

#### Slow Slew Rate for IA Domain

#### Slow Slew Rate for GT Domain

#### Slow Slew Rate for SA Domain

#### Slow Slew Rate for VccIn Domain

This feature controls the slow slew rate for a specific domain. The options are **Fast/2**, Fast/4, Fast/8, and Fast/16.

### ► Core/IA VR Settings

#### VR Config Enable

This feature enables VR Config. The options are Disabled and **Enabled**.

#### AC Loadline

Enter a value for AC Loadline.

### **DC Loadline**

Enter a value for DC Loadline.

### **PS Current Threshold1**

Enter a value for PS Current Threshold1. The range is 0-512. The default is **80**.

### **PS Current Threshold2**

Enter a value for PS Current Threshold2. The range is 0-512. The default is **20**.

### **PS Current Threshold3**

Enter a value for PS Current Threshold3. The range is 0-512. The default is **4**.

### **PS3 Enable**

This feature enables PS3. The options are Disabled and **Enabled**.

### **PS4 Enable**

This feature enables PS4. The options are Disabled and **Enabled**.

### **IMON Slope**

Enter a value for IMON Slope. The range is 0-200. The default is **0**.

### **IMON Offset**

Enter a value for IMON Offset. The range is 0-63999. The default is **0**.

### **IMON Prefix**

Use this feature to set the prefix value as a positive (+) or a negative (-). The options are "+-" and "-".

### **VR Current Limit**

Enter a value for the voltage regulator current limit, with each whole number equating to 1/4A (i.e., 400 = 100A). Enter 0 for Auto.

**VR Voltage Limit**

Enter a value (in mV) for the voltage regulator voltage limit. The range is 0-7999. Enter 0 for Auto.

**TDC Enable**

This feature enables TDC. The options are Disabled and **Enabled**.

**TDC Current Limit**

Enter a value for the TDC Current Limit, with each whole number equating to 1/8A (i.e., 1000 = 125A). The range is 0-32767. The default is **800**.

**TDC Time Window**

This feature controls the TDC Time Window. The options are **1 ms**, 2 ms, 3 ms, 4 ms, 5 ms, 6 ms, 7 ms, 8 ms, and 10 ms.

**TDC Lock**

This feature enables TDC Lock. The options are **Disabled** and Enabled.

**►GT VR Settings****VR Config Enable**

This feature enables VR Config. The options are Disabled and **Enabled**.

**AC Loadline**

Enter a value for AC Loadline.

**DC Loadline**

Enter a value for DC Loadline.

**PS Current Threshold1**

Enter a value for PS Current Threshold1. The range is 0-512. The default is **80**.

**PS Current Threshold2**

Enter a value for PS Current Threshold2. The range is 0-512. The default is **20**.

### **PS Current Threshold3**

Enter a value for PS Current Threshold3. The range is 0-512. The default is **4**.

### **PS3 Enable**

This feature enables PS3. The options are Disabled and **Enabled**.

### **PS4 Enable**

This feature enables PS4. The options are Disabled and **Enabled**.

### **IMON Slope**

Enter a value for IMON Slope. The range is 0-200. The default is **0**.

### **IMON Offset**

Enter a value for IMON Offset. The range is 0-63999. The default is **0**.

### **IMON Prefix**

Use this feature to set the prefix value as a positive (+) or a negative (-). The options are "+-" and "-".

### **VR Current Limit**

Enter a value for the voltage regulator current limit, with each whole number equating to 1/4A (i.e., 400 = 100A). Enter 0 for Auto.

### **VR Voltage Limit**

Enter a value (in mV) for the voltage regulator voltage limit. The range is 0-7999. Enter 0 for Auto.

### **TDC Enable**

This feature enables TDC. The options are Disabled and **Enabled**.

### **TDC Current Limit**

Enter a value for the TDC Current Limit, with each whole number equating to 1/8A (i.e., 1000 = 125A). The range is 0-32767. The default is **800**.

**TDC Time Window**

This feature controls the TDC Time Window. The options are **1 ms**, 2 ms, 3 ms, 4 ms, 5 ms, 6 ms, 7 ms, 8 ms, and 10 ms.

**TDC Lock**

This feature enables TDC Lock. The options are **Disabled** and Enabled.

**Intersil VR Command**

This feature enables Intersil VR Command to fix VR C-state issues. The options are **Disabled**, Send for IA/GT rails, and Send for IA/GT/SA rails.

**► Memory OverClocking**

This section displays the following memory profile information for Default, Custom, XMP1, and XMP2 profiles:

**tCK [MHz]**  
**tCL**  
**tRCD/tRP**  
**tRAS**  
**tCWL**  
**tFAW**  
**tREFI**  
**tRFC**  
**tRRD**  
**tRTP**  
**tWR**  
**tWTR**  
**NMode**  
**VDD [mV]**

**Realtime Memory Timing**

This feature enables realtime memory timing changes to be made after MRC\_DONE. The options are **Disabled** and Enabled.

**Memory profile**

This feature controls the memory profile. The options are **Default profile**, Custom profile, and XMP profile 1.

*\*When the Memory profile feature (above) is set to "Custom profile", the following memory timing configurations become available.*

### Memory Reference Clock

This feature controls the memory reference clock, in MHz. The options are **133** and 100.

### Memory Ratio

This feature controls the memory ratio. The memory frequency is equal to the memory ratio times the reference clock.

### Memory Voltage

Enter a value for the memory voltage override. The default is **1200**.

### QCLK Odd Ratio

If set to Enabled, this feature adds the Memory Reference Clock amount to the QCLK frequency. The options are **Disabled** and Enabled.



**Note:** When the Memory profile feature (above) is set to "Custom profile" the following memory timings may be manually changed. The defaults are listed below.

**tCL**  
**tRCD/tRP**  
**tRAS**  
**tCWL**  
**tFAW**  
**tREFI**  
**tRFC**  
**tRRD**  
**tRTP**  
**tWR**  
**tWTR**  
**NMode**  
**tRRD\_sg**  
**tRRD\_dg**  
**tRDRD\_sg**  
**tRDRD\_dg**  
**tRDRD\_dr**  
**tRDRD\_dd**  
**tRDWR\_sg**  
**tRDWR\_dg**  
**tRDWR\_dr**  
**tRDWR\_dd**  
**tWRRD\_sg**  
**tWRRD\_dg**  
**tWRRD\_dr**  
**tWRRD\_dd**

**tWRWR\_sg**  
**tWRWR\_dg**  
**tWRWR\_dr**  
**tWRWR\_dd**  
**tCKE**

#### **ODT RTT WR(CHA)**

This feature controls ODT RTT WR(CHA). The options are **Auto**, 0, 80, 120, 240, and 255.

#### **ODT RTT PARK(CHA)**

This feature controls ODT RTT PARK(CHA). The options are **Auto**, 0, 34, 40, 48, 60, 80, 120, and 240.

#### **ODT RTT NOM(CHA)**

This feature controls ODT RTT NOM(CHA). The options are **Auto**, 0, 34, 40, 48, 60, 80, 120, and 240.

#### **ODT RTT WR(CHB)**

This feature controls ODT RTT WR(CHB). The options are **Auto**, 0, 80, 120, 240, and 255.

#### **ODT RTT PARK(CHB)**

This feature controls ODT RTT PARK(CHB). The options are **Auto**, 0, 34, 40, 48, 60, 80, 120, and 240.

#### **ODT RTT NOM(CHB)**

This feature controls ODT RTT NOM(CHB). The options are **Auto**, 0, 34, 40, 48, 60, 80, 120, and 240.

**RcompTarget[RdOdt]**  
**RcompTarget[WrdS]**  
**RcompTarget[WrdSCmd]**  
**RcompTarget[WrdSCtl]**  
**RcompTarget[WrdSClk]**  
**SCompDq StageDelayPS**  
**SCompCmd StageDelayPS**  
**SCompCtl StageDelayPS**  
**SCompClk StageDelayPS**  
**RTLatency\_CH0\_DIMM0**  
**RTLatency\_CH1\_DIMM0**  
**IOLatency\_CH0\_DIMM0**  
**IOLatency\_CH1\_DIMM0**

**DIIBwEn[0]**  
**DIIBwEn[1]**  
**DIIBwEn[2]**  
**DIIBwEn[3]**

## ► Graphics OverClocking

### **GT OverClocking Frequency**

Enter a value for the overclocked RPO frequency (in multiples of 50 MHz) in the GT domain. The default is **0**.

### **GT Voltage Mode**

This feature controls the voltage mode in the GT domain. The options are **Adaptive** and Override.

### **GT Voltage Override**

When "GT Voltage Mode" is set to Override, enter a value for the GT Voltage Override.

### **GT Extra Turbo Voltage**

Enter a value for the extra turbo voltage (in mV) that will be applied while GT is operating in turbo mode. The default is **0**.

### **GT Voltage Offset**

Enter a value for the offset voltage (in mV) that will be applied to the GT domain. The default is **0**.

### **Offset Prefix**

Use this feature to set the prefix value as a positive (+) or a negative (-). The options are "+" and "-".

### **GT OverClocking Frequency**

Enter a value for the overclocked RPO frequency (in multiples of 50 MHz) in the GT Unslice domain. The default is **0**.

### **GT Voltage Mode**

This feature controls the voltage mode in the GT Unslice domain. The options are **Adaptive** and Override.

### **GT Voltage Override**

When "GT Voltage Mode" is set to Override, enter a value for the GT Voltage Override.

**GT Extra Turbo Voltage**

Enter a value for the extra turbo voltage (in mV) that will be applied while GT is operating in turbo mode. The default is **0**.

**GTU Voltage Offset**

Enter a value for the offset voltage (in mV) that will be applied to the GT domain. The default is **0**.

**Offset Prefix**

Use this feature to set the prefix value as a positive (+) or a negative (-). The options are "+" and "-".

**► Voltage Configuration****System Agent Voltage (mV)**

Enter a value for the System Agent voltage (in mV). The default is **1056**.

**Core Voltage Mode**

This feature controls the core voltage mode. The options are **Adaptive** and **Override**.

**SVID**

When "Core Voltage Mode" is set to **Override**, this feature enables SVID. The options are **Disabled** and **Enabled**.

**Core Voltage Override**

When "Core Voltage Mode" is set to **Override**, enter a value for the Core Voltage Override. The default is **0**.

**Core Extra Turbo Voltage**

Enter a value for the extra turbo voltage (in mV) that will be applied while IA Core is operating in turbo mode. The default is **0**.

**Core Voltage Offset**

Enter a value for the offset voltage (in mV) that will be applied to the IA Core domain. The default is **0**.

**Offset Prefix**

Use this feature to set the prefix value as a positive (+) or a negative (-). The options are "+" and "-".

### **Vcc\_PLL**

Enter a value for the Vcc\_PLL override. The default is **1000**.

### **Vcc\_ST**

Enter a value for the Vcc\_ST override. The default is **1000**.

### **PCH Voltage**

Enter a value for the PCH voltage override. The default is **1010**.

### **PCH 1.8 Voltage**

Enter a value for the PCH 1.8 voltage override. The default is **1800**.

### **CPU PLL Voltage**

Enter a value for the CPU PLL voltage override. The default is **1200**.

### **CPU\_IO Voltage**

Enter a value for the CPU IO voltage override. The default is **936**.

### **VCC DMI Voltage**

Enter a value for the VCC DMI voltage override. The default is **1000**.

### **Load Line Calibration**

This feature controls the load line calibration. The options are Disabled, Level 1, Level 2, Level 3, Level 4, Level 5, Level 6, Level 7, and **Auto**.

## **►Uncore**

### **Uncore Voltage Offset**

Enter a value for the offset voltage (in mV) that will be applied to the Uncore domain. The default is **0**.

### **Offset Prefix**

Use this feature to set the prefix value as a positive (+) or a negative (-). The options are "+" and "-".

## **►Voltage PLL Trim Controls**

### **Core PLL Voltage Offset**

Enter a value for the Core PLL voltage offset, with each whole number equating to 17.5 mV. The range is 0-63. The default is **0**.

### **GT PLL Voltage Offset**

Enter a value for the GT PLL voltage offset, with each whole number equating to 17.5 mV. The range is 0-63. The default is **0**.

### **Ring PLL Voltage Offset**

Enter a value for the Ring PLL voltage offset, with each whole number equating to 17.5 mV. The range is 0-63. The default is **0**.

### **System Agent PLL Voltage Offset**

Enter a value for the System Agent PLL voltage offset, with each whole number equating to 17.5 mV. The range is 0-63. The default is **0**.

### **Memory Controller PLL Voltage Offset**

Enter a value for the Memory Controller PLL voltage offset, with each whole number equating to 17.5 mV. The range is 0-63. The default is **0**.

## 4-4 CPU



The following information is displayed in this section:

- **Type** - the brand, model name, model number of the CPU, and its rated clock speed
- **Speed** - the detected CPU speed
- **ID** - the unique CPU ID
- **Stepping** - the processor stepping
- **Number of Processors** - the number of cores detected
- **Microcode Revision** - the CPU's microcode patch version
- **GT Info** - the processor's GT Information
- **IGFX VBIOS Version** - the Integrated Graphics VBIOS version
- **IGFX GOP Version** - the Integrated Graphics VOP version
- **Memory RC Version** - the memory RC version

## ► CPU Configuration

The following CPU information will be displayed:

- **Type** - the brand, model name, model number of the CPU, and its rated clock speed
- **ID** - the unique CPU ID
- **Speed** - the detected CPU speed
- **L1 Data Cache** - displays if Level 1 cache is supported
- **L1 Instruction Cache** - displays if Level 1 instruction cache is supported
- **L2 Cache** - displays if Level 2 cache is supported
- **L3 Cache** - displays if Level 3 cache is supported
- **VMX** - displays if VMX is supported
- **SMX/TXT** - displays if SMX/TXT is supported

## C6DRAM

This feature enables moving DRAM contents to PRM memory when the CPU is in a C6 state. The options are Disabled and **Enabled**.

## SW Guard Extension (SGX)

Select Enabled to activate the Software Guard Extensions (SGX). The options are Enabled, Disabled, and **Software Controlled**.

## Select Owner EPOCH Input Type

There are three Owner EPOCH modes (each EPOCH is 64 bit). The options are **No Change in Owner EPOCHs**, Change to New Random Owner EPOCH, and Manual User Defined Owner EPOCHs.

## Hardware Prefetcher

*(Available when supported by the CPU)*

If set to Enabled, the hardware prefetcher will prefetch streams of data and instructions from the main memory to the L2 cache to improve CPU performance. The options are Disabled and **Enabled**.

### **Adjacent Cache Line Prefetch**

*(Available when supported by the CPU)*

Select Enabled for the CPU to prefetch both cache lines for 128 bytes as comprised. Select Disabled for the CPU to prefetch both cache lines for 64 bytes. The options are Disabled and **Enabled**.

### **Intel (VMX) Virtualization Technology**

*(Available when supported by the CPU)*

Select Enabled to use the Intel Virtualization Technology to allow one platform to run multiple operating systems and applications in independent partitions, creating multiple "virtual" systems in one physical computer. The options are Disabled and **Enabled**.



**Note:** If there is any change to this setting, you will need to power off and reboot the system for the change to take effect. Please refer to Intel's website for detailed information.

### **Active Processor Cores**

Use this feature to select the number of active processor cores. The default option is **All**. The available options depend on how many cores are supported by the CPU.

### **Hyper-Threading *(when supported by the CPU)***

Select Enabled to support Intel Hyper-threading Technology to enhance CPU performance. The options are Disabled and **Enabled**.

### **BIST**

Select Enabled to activate the Built-In Self Test (BIST) on reset. The options are **Disabled** and Enabled.

### **AES**

Select Enable for Intel CPU Advanced Encryption Standard (AES) Instructions support to enhance data integrity. The options are Disabled and **Enabled**.

### **Machine Check**

Select Enable to activate Machine Check. The options are Disabled and **Enabled**.

### **MonitorMWait**

Select Enable to activate MonitorMWait. The options are Disabled and **Enabled**.

**TXT support (when supported by the CPU)**

Intel TXT (Trusted Execution Technology) helps protect against software-based attacks and ensures protection, confidentiality and integrity of data stored or created on the system. The options are **Disabled** and Enabled.

**Reset AUX Content (when supported by the CPU)**

Use this feature to reset the TPM Auxiliary content. The options are Yes and **No**.

**FCLK Frequency for Early Power On**

Select the FCLK frequency for early power on. The options are **Normal (800MHz)**, 1GHz, and 400MHz.

**► Power and Performance****► CPU - Power Management Control****Boot Performance Mode**

This feature enables the selection of the default CPU performance during system boot. The options are **Max Non-Turbo Performance**, Max Battery, and Turbo Performance.

**Intel(R) SpeedStep(tm)**

Intel SpeedStep Technology allows the system to automatically adjust processor voltage and core frequency in an effort to reduce power consumption and heat dissipation. **Please refer to Intel's website for detailed information.** The options are Disabled and **Enabled**.

**C states**

C-States architecture, a processor power management platform developed by Intel, can further reduce power consumption from the basic C1 (Halt State) state that blocks clock cycles to the CPU. Select Enabled for CPU C-States support. The options are Disabled and **Enabled**.

### **Enhanced C-states**

This feature enables Enhanced C1 Power State to lower system energy consumption while all cores are in C-State. The options are Disabled and **Enabled**.

### **C-State Auto Demotion**

When this feature is enabled, the CPU will conditionally demote C-State based on un-cored auto-demote information. The options are Disabled, C1, C3, and **C1 and C3**.

### **C-State Un-demotion**

When this feature is enabled, the CPU will conditionally un-demote from demoted C3 or C1. The options are Disabled, C1, C3, and **C1 and C3**.

### **Package C-State Demotion**

This feature enables the Package C-State demotion. The options are **Disabled** and Enabled.

### **Package C-State Un-Demotion**

When this feature is enabled, the CPU will conditionally un-demote from demoted Packaged Package C-State Un-Demotion. The options are **Disabled** and Enabled.

### **CState Pre-Wake**

This feature enables the C-State pre wake. The options are Disabled and **Enabled**.

### **IO MWAIT Redirection**

When enabled, this feature will map and send the I/O read instructions to the I/O registers. The options are **Disabled** and Enabled.

### **Package C State Limit**

Select Auto for the AMI BIOS to automatically set the limit on the C-State package register. The options are C0/C1, C2, C3, C6, C7, C7S, C8, C9, C10, CPU Default, and **Auto**.

### **Package C State Workaround**

This feature enables a workaround for Package C-State 6/7. The options are **Disabled** and Enabled.

## ▶GT - Power Management Control

### **RC6 (Render Standby)**

Use this feature to enable Render Standby support. The options are Disabled and **Enabled**.

### **Maximum GT Frequency**

This feature defines the Maximum GT Frequency. Choose between 100MHz (RPN) and 1200MHz (RP0). Any value beyond this range will be clipped to its min/max supported by the CPU. The options are **Default Max Frequency** and 100MHz~1200MHz (in increments of 50MHz).

### **Disable Turbo GT frequency**

This feature disables Turbo GT frequency. If set to Enabled, Turbo GT frequency becomes disabled. If set to Disabled, GT frequency limiters will be removed. The options are **Disabled** and Enabled.

## 4-5 Memory



The following information is displayed:

- **Memory RC Version**
- **Memory Frequency**
- **Memory Timings (tCL-tRCD-tRP-tRAS)**
- **DIMM#A1 ~ DIMM#B2**

### Maximum Memory Frequency

This feature selects the type/speed of the memory installed. The options are 1333, 1600, 1867, 2133, 2400, and 2667. All values are in MHz.

**Default speed is auto detected.**

### Memory Scrambler

This feature enables memory scrambler support for memory error correction. The options are Disabled and **Enabled**.

### Force ColdReset

Use this feature when ColdBoot is required during MRC execution. The options are **Disabled** and Enabled.

**Force Single Rank**

When enabled, only Rank0 will be use in each DIMM. The options are **Disabled** and Enabled.

**Memory Remap**

PCI memory resources will overlap with the total physical memory if 4GB of memory (or above) is installed on the motherboard. When this occurs, Enable this function to reallocate the overlapped physical memory to a location above the total physical memory to resolve the memory overlapping situation. The options are Disabled and **Enabled**.

**MRC Fast Boot**

This feature enables or disables fast path through MRC. The options are Disabled and **Enabled**.

## 4-6 Advanced

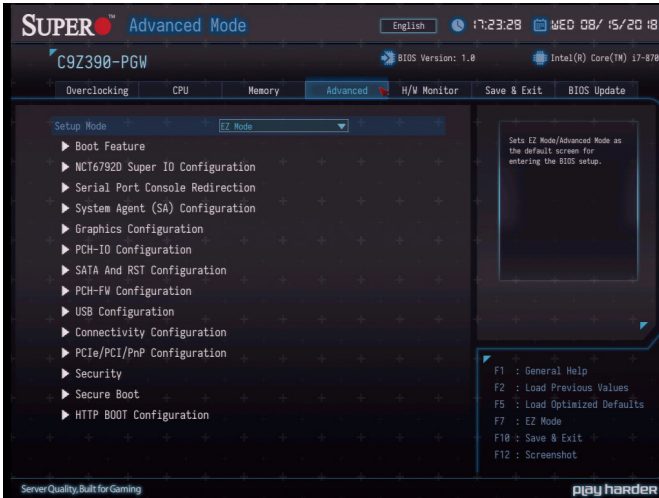

### Setup Mode

This feature sets the default mode to start in after entering BIOS. The options are **EZ Mode** and Advanced Mode.

### ► Boot Feature

#### Fast Boot

This feature enables the system to boot with a minimal set of required devices to launch. This has no effect on BBS boot options. The options are **Disabled** and Enabled.

#### Quiet Boot

Use this feature to select the screen display between the POST messages and the OEM logo upon bootup. Uncheck the box to display the POST messages. Check the box to display the OEM logo instead of the normal POST messages. The default is **Checked**.

#### Bootup NumLock State

Use this feature to set the Power-on state for the <Numlock> key. The options are Off and **On**.

### **Wait For "F1" If Error**

Use this feature to force the system to wait until the "F1" key is pressed if an error occurs. The options are Disabled and **Enabled**.

### **Re-try Boot**

If this feature is enabled, the BIOS will automatically reboot the system from a specified boot device after its initial boot failure. The options are **Disabled**, Legacy Boot, and EFI Boot.

### **Watch Dog Function**

If enabled, the Watch Dog Timer will allow the system to reset or generate NMI based on jumper settings when it is expired for more than five minutes. The options are **Disabled** and Enabled.

### **AC Loss Policy Depend on**

Use this feature to set the power state after a power outage. Select Stay Off for the system power to remain off after a power loss. Select Power On for the system power to be turned on after a power loss. Select Last State to allow the system to resume its last power state before a power loss. The options are Stay Off, Power On, and **Last State**.

### **Power Button Function**

This feature controls how the system shuts down when the power button is pressed. Select 4 Seconds Override for the user to power off the system after pressing and holding the power button for four seconds or longer. Select Instant Off to instantly power off the system as soon as the user presses the power button. The options are **Instant Off** and 4 Seconds Override.

### **DeepSx Power Policies**

This feature enables DeepSx Power Policy configuration. The options are **Disabled** and Enabled in S4-S5.

### **Install Windows 7 USB Support**

Enable this feature to use the USB keyboard and mouse during the Windows 7 installation since the native XHCI driver support is unavailable. Use a SATA optical drive as a USB drive. USB CD/DVD drives are not supported. Disable this feature after the XHCI driver has been installed in Windows. The options are **Disabled** and Enabled.

## RGB Led Control

This feature enables RGB LED controls. The options are Disabled and **Enabled**.

## ► NCT6792D Super IO Configuration

**Super IO Chip** - NCT6792D

### ► Serial Port 1 Configuration

#### Serial Port

This feature will Enable or Disable Serial Port 1 (COM1). Check the box to enable Serial Port 1. The default is **Checked**.

**Device Settings** - IO=3F8h; IRQ=4;

#### Change Settings

This feature configures the IRQ setting for Serial Port 1 (COM1).

The options for Serial Port 1 are **Auto**, "IO=3F8h; IRQ=4", "IO=3F8h; IRQ=3, 4, 5, 6, 7, 9, 10, 11, 12", "IO=2F8h; IRQ=3, 4, 5, 6, 7, 9, 10, 11, 12", "IO=3E8h; IRQ=3, 4, 5, 6, 7, 9, 10, 11, 12", and "IO=2E8h; IRQ=3, 4, 5, 6, 7, 9, 10, 11, 12".

## ► Serial Port Console Redirection

### COM1 Console Redirection

This feature enables COM Port 1 Console Redirection, which will allow a client machine to be connected to a host machine at a remote site for networking. The options are **Disabled** and Enabled.

*\*If the feature above is set to Enabled, the following features will become available for configuration:*

### ► COM1 Console Redirection Settings

#### COM1 Terminal Type

This feature allows the user to select the target terminal emulation type for Console Redirection. Select VT100 to use the ASCII Character set. Select VT100+ to add color and function key support. Select ANSI to use the Extended ASCII Character Set. Select VT-UTF8 to use UTF8 encoding to map Unicode characters into one or more bytes. The options are ANSI, VT100, **VT100+**, and VT-UTF8.

### **COM1 Bits per second**

Use this feature to set the transmission speed for a serial port used in Console Redirection. Make sure that the same speed is used in the host computer and the client computer. A lower transmission speed may be required for long and busy lines. The options are 9600, 19200, 38400, 57600, and **115200** (bits per second).

### **COM1 Data Bits**

Use this feature to set the data transmission size for Console Redirection. The options are 7 (Bits) and **8** (Bits).

### **COM1 Parity**

A parity bit can be sent along with regular data bits to detect data transmission errors. Select Even if the parity bit is set to 0, and the number of 1's in data bits is even. Select Odd if the parity bit is set to 0, and the number of 1's in data bits is odd. Select None if you do not want to send a parity bit with your data bits in transmission. Select Mark to add a mark as a parity bit to be sent along with the data bits. Select Space to add a Space as a parity bit to be sent with your data bits. The options are **None**, Even, Odd, Mark, and Space.

### **COM1 Stop Bits**

A stop bit indicates the end of a serial data packet. Select 1 Stop Bit for standard serial data communication. Select 2 Stop Bits if slower devices are used. The options are **1** and 2.

### **COM1 Flow Control**

Use this feature to set the flow control for Console Redirection to prevent data loss caused by buffer overflow. Send a "Stop" signal to stop sending data when the receiving buffer is full. Send a "Start" signal to start sending data when the receiving buffer is empty. The options are **None** and Hardware RTS/CTS.

### **COM1 VT-UTF8 Combo Key Support**

Select Enabled to enable VT-UTF8 Combination Key support for ANSI/VT100 terminals. The options are Disabled and **Enabled**.

### **COM1 Recorder Mode**

Select Enabled to capture the data displayed on a terminal and send it as text messages to a remote server. The options are **Disabled** and Enabled.

### **COM1 Resolution 100x31**

Select Enabled for extended-terminal resolution support. The options are Disabled and **Enabled**.

### **COM1 Legacy OS Redirection Resolution**

Use this feature to select the number of rows and columns used in Console Redirection for legacy OS support. The options are 80x24 and **80x25**.

### **COM1 Putty KeyPad**

This feature selects Function Keys and KeyPad settings for Putty, which is a terminal emulator designed for the Windows OS. The options are **VT100**, LINUX, XTERMR6, SCO, ESCN, and VT400.

### **COM1 Redirection After BIOS POST**

Use this feature to enable or disable legacy Console Redirection after BIOS POST. When the option Bootloader is selected, legacy Console Redirection is disabled before booting the OS. When the option Always Enable is selected, legacy Console Redirection remains enabled upon OS bootup. The options are **Always Enable** and Bootloader.

## **EMS Console Redirection**

This feature enables EMS Console Redirection, which will allow a client machine to be connected to a host machine at a remote site for networking. The options are **Disabled** and Enabled.

*\*If the feature above is set to Enabled, the following features will become available for configuration:*

## **► Console Redirection Settings**

### **EMS Terminal Type**

Use this feature to select the target terminal emulation type for Console Redirection. Select VT100 to use the ASCII character set. Select VT100+ to add color and function key support. Select ANSI to use the extended ASCII character set. Select VT-UTF8 to use UTF8 encoding to map Unicode characters into one or more bytes. The options are ANSI, VT100, VT100+, and **VT-UTF8**.

### EMS Bits per second

This feature sets the transmission speed for a serial port used in Console Redirection. Make sure that the same speed is used in both host computer and the client computer. A lower transmission speed may be required for long and busy lines. The options are 9600, 19200, 57600, and **115200** (bits per second).

### EMS Flow Control

Use this feature to set the flow control for Console Redirection to prevent data loss caused by buffer overflow. Send a "Stop" signal to stop data sending when the receiving buffer is full. Send a "Start" signal to start data sending when the receiving buffer is empty. The options are **None**, Hardware RTS/CTS, and Software Xon/Xoff.

The setting for each of these features is displayed:

**Data Bits**  
**Parity**  
**Stop Bits**

## ► System Agent (SA) Configuration

The following information will be displayed:

- **SA PCIe Code Version**
- **VT-d Capability**

## ► PEG Port Configuration

### PEG 0:1:0

#### Enable Root Port

Select Enable to activate the Root Port. The options are Disabled, Enabled, and **Auto**.

#### Max Link Speed

Select **Auto**, Gen1, Gen2, or Gen3 to set the PEG Max Link Speed.

## VT-d

This feature enables VT-d. The options are Disabled and **Enabled**.

### **GNA Device (B0:D8:F0)**

This feature enables the SA GNA device. The options are Disabled and **Enabled**.

### **X2APIC Opt Out**

This feature enables X2APIC Opt Out. The options are **Disabled** and Enabled.

## **►Graphics Configuration**

### **Graphics Turbo IMON Current**

Enter a value for the graphics turbo IMON current. The range is 14-31. The default is **31**.

### **Skip Scanning of External Gfx Card**

This feature disables scanning for external graphics cards. When this feature is set to Enabled, the system will not scan for external graphics cards on PEG and PCH PCI-E ports. The options are **Disabled** and Enabled.

### **Primary Display**

This feature controls which graphics device will be used as the primary display. The options are **Auto**, IGFX, PEG, PCI, and SG.

### **SG Delay After Power Enable**

Enter a value for Switchable Graphics Delay after power on. The default is **300**.

### **SG Delay After Hold Reset**

Enter a value for Switchable Graphics Delay after hold reset. The default is **100**.

## **►External Gfx Card Primary Display Display Configuration**

### **Primary PEG**

This feature controls the graphics device to be used as the primary device. The default is **Auto**, CPU SLOT1 PCI-E 3.0 X8 (IN X16), CPU SLOT3 PCI-E 3.0 X16, CPU SLOT5 PCI-E 3.0 X8 (IN X16), and CPU SLOT7 PCI-E 3.0 X16.

### Primary PCIE

This feature controls the primary PCI-E device. The options are **Auto** and PCH SLOT4 PCI-E 3.0 x1.

### Internal Graphics

This feature enables the internal graphics support, based on the setup options. The options are **Auto**, Disabled, and Enabled.

### GTT Size

This feature controls the memory allocation size for the graphics translation table (GTT). The options are 2MB, 4MB, and **8MB**.

### Aperture Size

This feature controls the graphics aperture size. For optimal performance, select the size that matches the installed graphics card's size. The options are 128MB, **256MB**, 512MB, 1024MB, and 2048MB.

### DVMT Pre-Allocated

This feature controls the DVMT 5.0 Pre-allocated graphics memory size to be used by the internal graphics device. The options are 0M, **32M**, 64M, 4M, 8M, 12M, 16M, 20M, 24M, 28M, 32M/F7, 36M, 40M, 44M, 48M, 52M, 56M, and 60M.

### DVMT Total Gfx Mem

This feature controls the DVMT 5.0 total graphics size to be used by the internal graphics device. The options are 128M, **256M**, and MAX.

### VDD Enable

This feature enables VDD in the BIOS. The options are Disabled and **Enabled**.

### PM Support

This feature enables PM support. The options are Disabled and **Enabled**.

### PAVP Enable

This feature enables PAVP support. The options are Disabled and **Enabled**.

### Cdynmax Clamping Enable

This feature enables Cdynmax Clamping. The options are Disabled and **Enabled**.

### Graphics Clock Frequency

This feature controls the graphics clock frequency. Select the highest clock frequency supported by the platform. The options are 337.5 Mhz, 450 Mhz, 540 Mhz, and **675 Mhz**.

### Skip CD Clock Init in S3 resume

This feature enables skipping the full CD clock initialization. If set to Disabled, the full CD clock will initialize. The options are **Disabled** and Enabled.

## ► PCH-IO Configuration

### HD Audio

This feature controls the detection of HD Audio devices. The options are Disabled and **Enabled**.

### Wake on LAN Enable

This feature enables integrated LAN to wake the system. The options are Disabled and **Enabled**.

### PCIe PLL SSC

This feature controls the PCIe PLL SSC setting. The options are **Auto** and 0.0~2.0% (in 0.1% increments).

### DMI Link ASPM Control

This feature configures Active State Power Management (ASPM) for DMI Link. The options are Disabled and **Enabled**.

### PCH SLOT4 ASPM

This feature configures the ASPM (Active State Power Management) settings for PCH Slot 4. The options are Disabled, L0s, L1, L0sL1, and **Auto**.

### PCH SLOT4 L1 Substates

This feature configures the L1 substate for PCH Slot 4. The options are Disabled, L1.1, and **L1.1 & L1.2**.

### M.2-M2 ASPM

This feature configures the ASPM (Active State Power Management) settings for M.2-M2. The options are Disabled, L0s, L1, L0sL1, and **Auto**.

**M.2-M2 L1 Substates**

This feature configures the L1 substate for M.2-M2. The options are Disabled, L1.1, and **L1.1 & L1.2**.

**M.2-M1 ASPM**

This feature configures the ASPM (Active State Power Management) settings for M.2-M1. The options are Disabled, L0s, L1, L0sL1, and **Auto**.

**M.2-M1 L1 Substates**

This feature configures the L1 substate for M.2-M1. The options are Disabled, L1.1, and **L1.1 & L1.2**.

**►SATA And RST Configuration****SATA Controller(s)**

This feature enables SATA device(s). The options are Disabled and **Enabled**.

**SATA Mode Selection**

This feature controls SATA mode(s). The options are **AHCI** and Intel RST With Intel Optane System Acceleration.

**RAID Mode Selection**

This feature is only available when "SATA Mode Selection" is set to Intel RST With Optane System Acceleration. The options are **iRST Mode** and Alternate.

**PCI-E M.2-M1****PCI-E M.2-M2**

These features become configurable if an M.2 device is installed.

**Aggressive LPM Support**

This feature enables the PCH to aggressively enter link power state. The options are Disabled and **Enabled**.

**Storage Option ROM/UEFI Driver**

This feature controls the execution of UEFI or legacy storage option ROM. The options are Do not launch, UEFI, and **Legacy**.

### **Serial ATA Port0~5 Hot Plug**

This feature designates the port specified for hot plugging. Set the setting to Enabled for hot-plugging support, which will allow the user to replace a SATA disk drive without shutting down the system. The options are Disabled and **Enabled**.

### **Spin Up Device**

When this feature is disabled, all drives will spin up at boot. When this option is enabled, it will perform Staggered Spin Up on any drive this option is activated. The options are **Disabled** and Enabled.

### **SATA Device Type**

Use this feature to identify the type of HDD that is connected to the SATA port. The options are **Hard Disk Drive** and Solid State Drive.

## **►PCH-FW Configuration**

Information for the following is displayed:

**ME Firmware Version**  
**ME Firmware Mode**  
**ME Firmware SKU**

### **ME FW Image Re-Flash**

This feature enables an update to the PCH firmware from an image in a USB flash drive attached to a USB port. The options are **Disabled** and Enabled.

## **►USB Configuration**

### **Legacy USB Support**

Select Enabled to support legacy USB devices. Select Auto to disable legacy support when legacy USB devices are not present. If Disable is selected, legacy USB devices will not be supported. The options are Disabled, **Enabled**, and Auto.

### **XHCI Hand-off**

This feature is a work-around solution for operating systems that do not support XHCI (Extensible Host Controller Interface) hand-off. The XHCI ownership change should be claimed by the XHCI driver. The options are Disabled and **Enabled**.

## USB Mass Storage Driver Support

This feature enables USB mass storage driver support. The options are Disabled and **Enabled**.

## Port 60/64 Emulation

This feature enables I/O port 60h/64h emulation for legacy USB keyboard support on non-USB aware operating systems. The options are Disabled and **Enabled**.

## ►Connectivity Configuration

### CNVi WiFi&BT

This feature enables CNVi WiFi and Bluetooth support. The options are Disabled and **Enabled**.

## ►PCIe/PCI/PnP Configuration

### Video

This feature controls which option ROM to execute for the video device. The options are Do Not Launch, UEFI, and **Legacy**.

### Above 4GB MMIO BIOS assignment

Select Enable for remapping of BIOS above 4GB. The options are **Disabled** and Enabled.

### CPU SLOT1 PCI-E 3.0 X8 (IN X16) OPROM

### CPU SLOT3 PCI-E 3.0 X16 OPROM

### PCH SLOT4 PCI-E 3.0 X1 OPROM

### CPU SLOT5 PCI-E 3.0 X8 (IN X16) OPROM

### CPU SLOT7 PCI-E 3.0 X16 OPROM

### PCIE M.2-M1 OPROM

### PCIE M.2-M2 OPROM

### PCIE M.2-E1 OPROM

Select Disabled to deactivate the selected slot, Legacy to activate the slot in legacy mode, and EFI to activate the slot in EFI mode. The options are Disabled, **Legacy**, and EFI.

### Onboard LAN1 SUPPORT

Use this feature to enable the onboard LAN1 device. The options are Disabled and **Enabled**.

### **Onboard LAN2 SUPPORT**

Use this feature to enable the onboard LAN2 device. The options are Disabled and **Enabled**.

### **Onboard LAN Option ROM Type**

Use this feature to select the type of option ROM installed. The options are EFI and **Legacy**.

### **Onboard LAN1 Option ROM**

Select PXE (Preboot Execution Environment) to boot the computer using a PXE device installed in a LAN port specified. Select Disabled to prevent system boot using a device installed in a LAN port. The options are Disabled and **PXE**.

### **Onboard LAN2 Option ROM**

Select PXE (Preboot Execution Environment) to boot the computer using a PXE device installed in a LAN port specified. Select Disabled to prevent system boot using a device installed in a LAN port. The options are **Disabled**, Legacy, and EFI.

### **Network Stack**

Select Enabled to enable PXE (Preboot Execution Environment) or UEFI (Unified Extensible Firmware Interface) for network stack support. The options are Disabled and **Enabled**.

*\*If this feature is enabled, the two features below are available.*

### **Ipv4 PXE Support**

Select Enabled to enable IPv4 PXE (Preboot Execution Environment) for boot support. If this feature is set to Disabled, IPv4 PXE boot option will not be supported. The options are Disabled and **Enabled**.

### **Ipv4 HTTP Support**

Use this feature to enable IPv4 HTTP boot support. The options are **Disabled** and Enabled.

### **Ipv6 PXE Support**

Select Enabled to enable IPv6 PXE (Preboot Execution Environment) for boot support. If this feature is set to Disabled, IPv6 PXE boot option will not be supported. The options are Disabled and **Enabled**.

### Ipv6 HTTP Support

Use this feature to enable IPv6 HTTP boot support. The options are **Disabled** and **Enabled**.

### IPSEC Certificate

This feature enables IPSEC certificate for Ikev. The options are **Disabled** and **Enabled**.

### PXE boot wait time

Enter a value for the wait time (in seconds) to press the ESC key to abort the PXE boot. The default is **0**.

### Media detect count

Enter a value for the number of times the presence of media will be checked. The default is **1**.

## ► Trusted Computing



**Note:** This submenu will only appear when a TPM device is installed.

**Firmware Version** - The TPM device's firmware version

**Vendor** - The TPM device's vendor

### Security Device Support

This feature enables BIOS support for security devices. The options are **Disabled** and **Enabled**.

**Active PCR banks** - A list of active PCR banks

**Available PCR banks** - A list of available PCR banks

### SHA-1 PCR Bank

This feature enables SHA-1 PCR Bank. The options are **Disabled** and **Enabled**.

### SHA256 PCR Bank

This feature enables SHA256 PCR Bank. The options are **Disabled** and **Enabled**.

### Pending operation

This feature schedules an operation for the security device. Changing this setting will reboot the system. The options are **None** and **TPM Clear**.

### **Platform Hierarchy**

This feature enables Platform Hierarchy. The options are Disabled and **Enabled**.

### **Storage Hierarchy**

This feature enables Storage Hierarchy. The options are Disabled and **Enabled**.

### **Endorsement Hierarchy**

This feature enables Endorsement Hierarchy. The options are Disabled and **Enabled**.

### **TPM2.0 UEFI Spec Version**

This feature controls the TCH2 spec version that is supported. The options are TCH\_1\_2 and **TCG\_2**.

### **Physical Presence Spec Version**

This feature controls the operating system support for a selected physical presence spec version. The options are 1.2 and **1.3**.

### **TPM 20 InterfaceType**

#### **PH Randomization**

This feature is for testing purposes. **Production motherboard users should keep this Disabled**.

#### **Device Select**

This feature controls the TPM device type that is supported. The options are TPM 1.2, TPM 2.0, and **Auto**.

### **►Security**

Use this submenu to create Administrator and User passwords. Using ONLY an Administrator password limits access to BIOS setup. Using ONLY a User password will lock unauthorized users from booting the system and/or entering BIOS setup.

### **►HDD Security Configuration**

Use this submenu to control access for setting, modifying, and clearing HDD User and master passwords.

## ► Secure Boot

The following information will be displayed:

- **System Mode**
- **Secure Boot**

### **Attempt Secure Boot**

Select Enabled for Secure Boot flow control. This feature is available when the platform key (PK) is pre-registered, the platform operates in the user mode, and CSM is disabled in the Setup utility. The options are **Disabled** and Enabled.

### **Secure Boot Mode**

This feature allows selection of the Secure Boot Mode between Standard and Custom. Selecting Custom enables users to change the Image Execution Policy and manage Secure Boot Keys. The options are **Custom** and Standard.

### **CSM Support**

Select enabled to support the Compatibility Support Module (CSM), which provides compatibility support for traditional legacy BIOS for system boot. The options are Disabled and **Enabled**.

## ► Key Management

### **Install Factory Default Keys**

This feature forces the system to install the factory default keys. Click Yes or No.

### **Reset to Setup Mode**

### **Save all Secure Boot variables**

This feature saves all revised Secure Boot settings.

### **Enroll Efi Image**

This feature allows the image to run in Secure Boot Mode. Enroll SHA256 Hash Certificate of the image into the Authorized Signature Database.

### **Restore DB defaults**

This feature restores DB variables to their factory defaults. Click Yes or No.

### **Platform Key (PK)**

This feature uploads and installs a secure Platform Key. You may insert a factory default key or load from a file. When prompted, select "Yes" to load Factory Defaults or "No" to load from a file.

### **Key Exchange Keys**

This feature uploads and installs a Key Exchange Key. You may insert a factory default key or load from a file. When prompted, select "Yes" to load Factory Defaults or "No" to load from a file.

### **Authorized Signatures**

This feature uploads and installs an Authorized Signature. You may insert a factory default key or load from a file. When prompted, select "Yes" to load Factory Defaults or "No" to load from a file.

### **Forbidden Signatures**

This feature uploads and installs a Forbidden Signature. You may insert a factory default key or load from a file. When prompted, select "Yes" to load Factory Defaults or "No" to load from a file.

### **Authorized TimeStamps**

This feature uploads and installs an Authorized Time Stamp. You may insert a factory default key or load from a file. When prompted, select "Yes" to load Factory Defaults or "No" to load from a file.

### **OsRecovery Signatures**

This feature uploads and installs an OSRecovery Signature. You may insert a factory default key or load from a file. When prompted, select "Yes" to load Factory Defaults or "No" to load from a file.

## **► HTTP BOOT Configuration**

### **Http Boot One Time**

This feature enables HTTP Boot, which is a client-server communication based application for system deployment and configuration over a network. The options are **Disabled** and Enabled.

**Input the description**

Enter a name for Http boot option.

**Boot URI**

Enter a value for a new Boot option to be created according to this Boot URI. The default is **0**.

**► Network Configuration**

This submenu becomes configurable when the "Onboard LAN Option ROM Type" feature within the PCIe/PCI/PnP Configuration submenu is set to EFI.

**► Intel(R) Rapid Storage Technology**

This submenu will only appear if the following requirements are met when entering BIOS:

1. The "Boot mode select" feature, within the Save & Exit menu, is set to "DUAL" or "UEFI".
2. The "SATA Mode Selection" feature, within the Advanced menu and then the SATA And RST Configuration submenu, is set to "Intel RST with Intel Optane System Acceleration".
3. The "Storage Option ROM/UEFI Driver" feature, within the Advanced menu and then the SATA And RST Configuration submenu, is set to "UEFI".

Information for installed storage drives will be viewable in this submenu.

**► Intel(R) Ethernet Connection (7)I219-V (XX:XX:XX:XX:XX:XX) Driver Health**

This submenu will only appear if the following requirements are met when entering BIOS:

1. The "Boot mode select" feature, within the Save & Exit menu, is set to "DUAL" or "UEFI".
2. The "Onboard LAN Option ROM Type" feature, within the Advanced menu and then the PCIe/PCI/PnP Configuration submenu, is set to "EFI".

## ►NIC Configuration

### Link Speed

This feature controls the port speed used for the selected boot protocol. The options are **Auto Negotiated**, 10 Mbps Half, 10 Mbps Full, 100 Mbps Half, and 100 Mbps Full.

### Wake On LAN

This feature enables the system to be powered on using an in-band packet. The options are Disabled and **Enabled**.

### Blink LEDs

Use this feature to identify a physical network port. Enter a number to force the associated network port LED to blink.

## PORT CONFIGURATION INFORMATION

Information for the LAN port configuration is displayed.

## ►Driver Health

This submenu will only appear if the following requirements are met when entering BIOS:

1. The "Boot mode select" feature, within the Save & Exit menu, is set to "DUAL" or "UEFI".
2. The "Onboard LAN Option ROM Type" feature, within the Advanced menu and then the PCIe/PCI/PnP Configuration submenu, is set to "EFI".

This submenu displays the health of the LAN and its related controller.

## 4-7 H/W Monitor



### System Temperature

The following items will be displayed:

- **CPU Temperature** - the CPU temperature detected by PECI
- **System Temperature** - the system internal temperature
- **Peripheral Temperature** - the detected peripheral device temperature
- **PCH Temperature** - the detected PCH chip temperature

### System Health

The voltages for the following items will be displayed:

- **VCPU**
- **12V**
- **VCCSA**

- **5VCC**
- **VDIMM**
- **VCPU\_IO**
- **PCH 1.0V**
- **3.3V\_DL**
- **USB**
- **3.3VCC**
- **VBAT**
- **VCPU\_STPLL**

## ► Fan Control

### Fan Speed Control Mode

This feature allows the user to decide how the system controls the speeds of the onboard fans. The CPU temperature and the fan speed are correlative. When the CPU on-die temperature increases, the fan speed will also increase for effective system cooling. Select "Full Speed" to allow the onboard fans to run at full speed (of 100% Pulse Width Modulation Duty Cycle) for maximum cooling. This setting is recommended for special system configuration or debugging. Select "Stable" for the onboard fans to run at 50% of the Initial PWM Cycle in order to balance the needs between system cooling and power saving. This setting is recommended for regular systems with normal hardware configurations. Select "Quiet" to optimize for minimal fan noise and Custom to enter user-specific settings. The options are **Quiet**, **Stable**, **Full Speed** and **Customize**.

When "Customize" is selected above, the settings for **CPU\_FAN1/ FAN2 Control**, **SYS FAN1/FAN2/FAN3 Control** will appear and can be configured.

## 4-8 Save & Exit

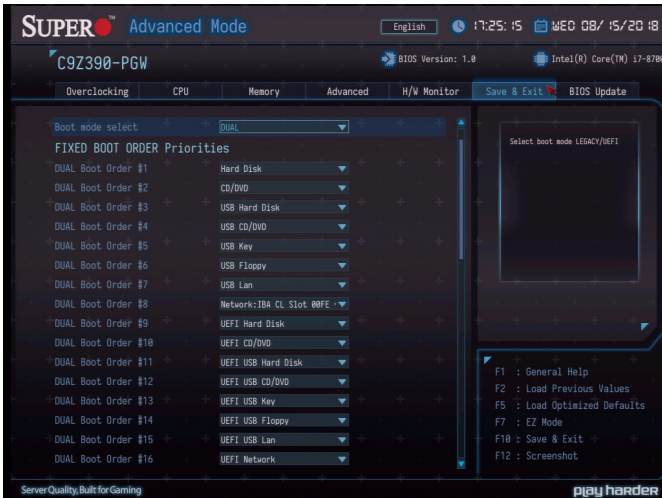

### Boot mode select

Use this feature to select the type of device to be used for system boot. The options are Legacy, UEFI, and **Dual**.

### FIXED BOOT ORDER Priorities

This feature prioritizes the order of bootable devices from which the system will boot. Choose an entry from top to bottom to select devices.

### Legacy Boot Option #1~#8

The options are Hard Disk, CD/DVD, USB Hard Disk, USB CD/DVD, USB Key, USB Floppy, USB LAN, Network, and Disabled.

### UEFI Boot Option #1~#9

These options display when "Boot mode select" is set to UEFI. The options are UEFI Hard Disk, UEFI AP: UEFI: Built-in EFI Shell, UEFI CD/DVD, UEFI USB Hard Disk, UEFI USB CD/DVD, UEFI USB Key, UEFI USB Floppy, UEFI USB Lan, UEFI Network, and Disabled.

### DUAL Boot Option #1~#17

These options display when "Boot mode select" is set to DUAL. The options contain all options from UEFI and Legacy boot modes.

### **Delete Boot Option**

Removes an EFI boot option from the boot order.

### **UEFI Application Boot Priorities**

Specifies the Boot Application Priority sequence from available UEFI Applications.

### **NETWORK Drive BBS Priorities**

Specifies the Boot Device Priority sequence from available Network Drives.

### **Boot Override**

Saves the specified boot override and resets the system, i.e., **IBA CL Slot 00FE v0110**. Select OK to activate, otherwise, click Cancel.

### **Save Options**

The Save Options section includes the following features:

- Save Changes and Reset**
- Discard Changes and Reset**
- Save Changes**
- Discard Changes**

### **Default Options**

The Default Options sections include the following features:

- Restore Defaults**
- Save as User Defaults**
- Restore User Defaults**
- Save Profile 1**
- Save Profile 2**
- Load Profile 1**
- Load Profile 2**

## 4-9 BIOS Update



The following items will be displayed:

**BIOS Version**  
**BIOS Tag**  
**Date**  
**Time**

### Start Update

Use this utility to prepare BIOS Update with ME.

1. Click "Start Update" enter the SuperFlash utility.
2. At the prompt, select "Yes" to reboot and configure the system to Flash mode. Select "No" to cancel and view the BIOS information.
3. After the system reboots to the flash mode, the system is ready to flash the BIOS. At the prompt, select "OK" to continue.
4. Select "Select File" and then in the pop-up menu select "General USB Flash Disk 1.00."
5. Select the filename (i.e., "C7Z390-PGW") in the pop-up menu.

6. Select "Start Flash" to flash the BIOS. A pop-up message will appear to show the progress of the BIOS flash.
  
7. If the flash is successful, a pop-up message will indicate the result. Select "OK" to complete the BIOS flash and to reboot the system. Check the System Information section of the BIOS Setup to check for the correct BIOS version.

## Appendix A

### BIOS Error Beep Codes

During the POST (Power-On Self-Test) routines, which are performed each time the system is powered on, errors may occur.

**Non-fatal errors** are those which, in most cases, allow the system to continue with bootup. The error messages normally appear on the screen.

**Fatal errors** will not allow the system to continue to bootup. If a fatal error occurs, you should consult with your system manufacturer for possible repairs.

The fatal errors are usually communicated through repeated patterns of audible beeps. Each pattern of audible beeps listed below corresponds to its respective error.

#### A-1 BIOS Error Beep Codes

BIOS Error Beep Codes		
Beep Code/LED	Error Message	Description
1 beep	Refresh	Circuits have been reset. (Ready to power up)
5 short beeps + 1 long beep	Memory error	No memory detected in the system
5 short beeps	Display error	System display error
OH LED On	System OH	System Overheat

## Notes

## Appendix B

### Software Installation Instructions

#### B-1 Installing Drivers

After you've installed the Windows Operating System, a screen as shown below will appear. You are ready to install software programs and drivers that have not yet been installed. To install these software programs and drivers, click the icons to the right of these items. (**Note:** To install the Windows Operating System, please refer to the instructions posted on our website at [http://www.supermicro.com/support/manuals/.](http://www.supermicro.com/support/manuals/))

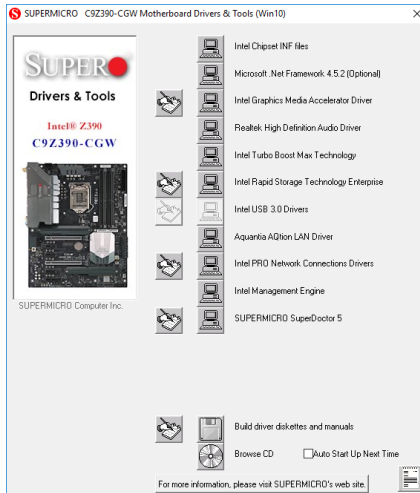

#### Driver/Tool Installation Display Screen



**Note 1:** Click the icons showing a hand writing on the paper to view the readme files for each item. Click on a computer icon to the right of an item to install this item (from top to bottom), one at a time. After installing each item, you must reboot the system before proceeding with the next item on the list. The bottom icon with a CD on it allows you to view the entire contents of the CD.

**Note 2:** When making a storage driver diskette by booting into a Driver CD, please set the SATA Configuration to "Compatible Mode" and configure SATA as IDE in the BIOS Setup. After making the driver diskette, be sure to change the SATA settings back to your original settings.

## B-2 Configuring SuperDoctor® 5

The SuperDoctor 5 program is a web-based management tool that supports remote management capability. It includes Remote and Local Management tools. The local management tool is called the SD 5 Client. The SuperDoctor 5 program included on the CDROM that came with your motherboard allows you to monitor the environment and operations of your system. SuperDoctor 5 displays crucial system information such as CPU temperature, system voltages, and fan status. See the Figure below for a display of the SuperDoctor 5 interface.



**Note 1:** The default user name and password are ADMIN.

**Note 2:** In the Windows OS environment, the SuperDoctor 5 settings take precedence over the BIOS settings. When first installed, SuperDoctor 5 adopts the temperature threshold settings previously set in BIOS. Any subsequent changes to these thresholds must be made within SuperDoctor, since the settings override the BIOS settings. For the Windows OS to adopt the BIOS temperature threshold settings, please change the SD 5 Client settings to be the same as those set in BIOS.

### SuperDoctor 5 Interface Display Screen-I (Health Information)

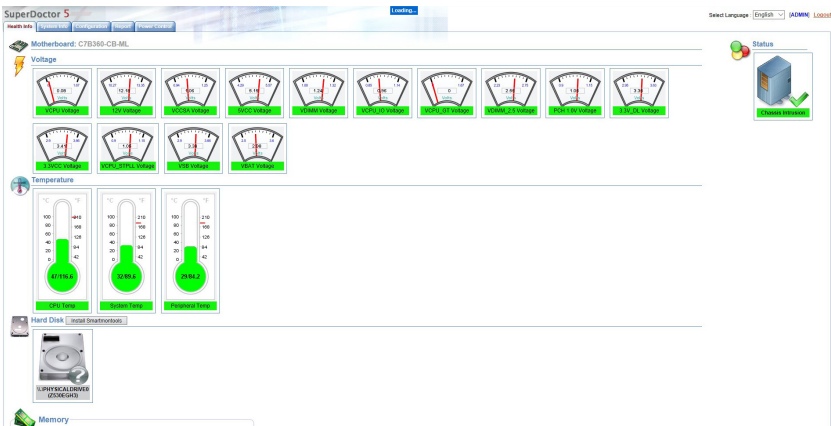

**Note:** The SuperDoctor 5 software and manual may be downloaded from our website at:

[https://www.supermicro.com/Products/nfo/SMS\\_SD5.cfm](https://www.supermicro.com/Products/nfo/SMS_SD5.cfm)

---

---

## Appendix C

### UEFI BIOS Recovery Instructions

**!** **Attention!** Do not upgrade the BIOS unless your system has a BIOS-related issue. Flashing the wrong BIOS can cause irreparable damage to the system. In no event shall Supermicro be liable for direct, indirect, special, incidental, or consequential damages arising from a BIOS update. If you need to update the BIOS, do not shut down or reset the system while the BIOS is updating to avoid possible boot failure.

#### C-1 An Overview to the UEFI BIOS

The Unified Extensible Firmware Interface (UEFI) specification provides a software-based interface between the operating system and the platform firmware in the pre-boot environment. The UEFI specification supports an architecture-independent mechanism for add-on card initialization to allow the UEFI OS loader, which is stored in the add-on card, to boot up the system. UEFI offers a clean, hands-off control to a computer system at bootup.

#### C-2 How to Recover the UEFI BIOS Image (the Main BIOS Block)

A UEFI BIOS flash chip consists of a recovery BIOS block, comprised of two boot blocks and a main BIOS block (a main BIOS image). The boot block contains critical BIOS codes, including memory detection and recovery codes for the user to flash a new BIOS image if the original main BIOS image is corrupted. When the system power is on, the boot block codes execute first. Once that is completed, the main BIOS code will continue with system initialization and bootup.

### C-3 To Recover the Main BIOS Block Using a USB-Attached Device

This feature allows the user to recover a BIOS image using a USB-attached device without additional utilities used. A USB flash device such as a USB Flash Drive, or a USB CD/DVD ROM/RW device can be used for this purpose. However, a USB Hard Disk drive cannot be used for BIOS recovery at this time.

To perform UEFI BIOS recovery using a USB-attached device, follow the instructions below.

1. Using a different machine, copy the "Super.ROM" binary image file into the disc Root "\\" Directory of a USB device or a writeable CD/DVD.



**Note:** If you cannot locate the "SUPER.ROM" file in your driver disk, visit our website at [www.supermicro.com](http://www.supermicro.com) to download the BIOS image into a USB flash device (save in the root folder) and rename it "SUPER.ROM" for BIOS recovery use.

2. Insert the USB device that contains the new BIOS image ("SUPER.ROM") into any available USB port. Be sure the file is saved in the very top (root) folder.
3. With the USB device inserted, power on the system. If the screen appears as below, press <DEL> to continue.

```
Version 2.16.1243. Copyright (C) 2013 American Megatrends, Inc.
Supermicro C7Z37-ODE BIOS Date:04/25/2014 Rev:1.0
CPU : Intel(R) Core(TM) i7-4765T CPU @ 2.00GHz
Speed : 2.00 GHz

The BMC is operating with DDR3L 1333 Mhz
Setup default has been loaded.
Press <DEL> to run Setup
Press <F1> to Continue Booting
```

- 4. After locating the new BIOS binary image, the system will enter the BIOS Recovery menu as shown below.

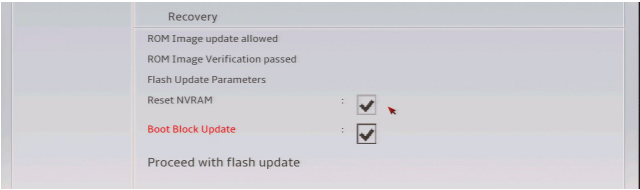

 **Note:** At this point, you may decide if you want to start with BIOS Recovery. If you decide to proceed with BIOS Recovery, follow the procedures below.

- 5. To continue with BIOS Recovery, select the item "Proceed with flash update". You will see the progress of BIOS Recovery as shown on the screens below.

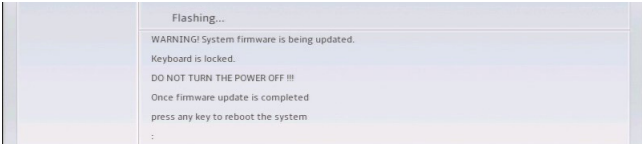

 **Note:** Do not interrupt the BIOS programming until it is completed.

- 6. After the BIOS Recovery process is complete, click OK to reboot the system.

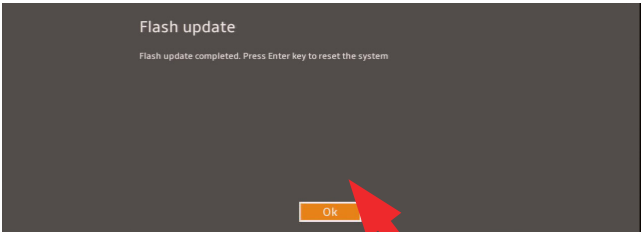

## Notes

(Disclaimer Continued)

The products sold by Supermicro are not intended for and will not be used in life support systems, medical equipment, nuclear facilities or systems, aircraft, aircraft devices, aircraft/emergency communication devices or other critical systems whose failure to perform be reasonably expected to result in significant injury or loss of life or catastrophic property damage. Accordingly, Supermicro disclaims any and all liability, and should buyer use or sell such products for use in such ultra-hazardous applications, it does so entirely at its own risk. Furthermore, buyer agrees to fully indemnify, defend and hold Supermicro harmless for and against any and all claims, demands, actions, litigation, and proceedings of any kind arising out of or related to such ultra-hazardous use or sale.