



SSE-C4632SB/SRB

USER'S GUIDE

Revision 1.2

The information in this User's Manual has been carefully reviewed and is believed to be accurate. The vendor assumes no responsibility for any inaccuracies that may be contained in this document, and makes no commitment to update or to keep current the information in this manual, or to notify any person or organization of the updates. Note: For the most up-to-date version of this manual, see our website at <https://www.supermicro.com>.

Super Micro Computer, Inc. ("Supermicro") reserves the right to make changes to the product described in this manual at any time and without notice. This product, including software and documentation, is the property of Supermicro and/or its licensors, and is supplied only under a license. Any use or reproduction of this product is not allowed, except as expressly permitted by the terms of said license.

IN NO EVENT WILL Super Micro Computer, Inc. BE LIABLE FOR DIRECT, INDIRECT, SPECIAL, INCIDENTAL, SPECULATIVE OR CONSEQUENTIAL DAMAGES ARISING FROM THE USE OR INABILITY TO USE THIS PRODUCT OR DOCUMENTATION, EVEN IF ADVISED OF THE POSSIBILITY OF SUCH DAMAGES. IN PARTICULAR, SUPER MICRO COMPUTER, INC. SHALL NOT HAVE LIABILITY FOR ANY HARDWARE, SOFTWARE, OR DATA STORED OR USED WITH THE PRODUCT, INCLUDING THE COSTS OF REPAIRING, REPLACING, INTEGRATING, INSTALLING OR RECOVERING SUCH HARDWARE, SOFTWARE, OR DATA.

Any disputes arising between manufacturer and customer shall be governed by the laws of Santa Clara County in the State of California, USA. The State of California, County of Santa Clara shall be the exclusive venue for the resolution of any such disputes. Supermicro's total liability for all claims will not exceed the price paid for the hardware product.

FCC Statement: This equipment has been tested and found to comply with the limits for a Class A or Class B digital device pursuant to Part 15 of the FCC Rules. These limits are designed to provide reasonable protection against harmful interference when the equipment is operated in industrial environment for Class A device or in residential environment for Class B device. This equipment generates, uses, and can radiate radio frequency energy and, if not installed and used in accordance with the manufacturer's instruction manual, may cause harmful interference with radio communications. Operation of this equipment in a residential area is likely to cause harmful interference, in which case you will be required to correct the interference at your own expense.

California Best Management Practices Regulations for Perchlorate Materials: This Perchlorate warning applies only to products containing CR (Manganese Dioxide) Lithium coin cells. "Perchlorate Material-special handling may apply. See <https://www.dtsc.ca.gov/hazardouswaste/perchlorate>".



WARNING: This product can expose you to chemicals including lead, known to the State of California to cause cancer and birth defects or other reproductive harm. For more information, go to <https://www.P65Warnings.ca.gov>.



AVERTISSEMENT : Ce produit peut vous exposer à des agents chimiques, y compris le plomb, identifié par l'État de Californie comme pouvant causer le cancer, des malformations congénitales ou d'autres troubles de la reproduction. Pour de plus amples informations, prière de consulter <https://www.P65Warnings.ca.gov>.

The products sold by Supermicro are not intended for and will not be used in life support systems, medical equipment, nuclear facilities or systems, aircraft, aircraft devices, aircraft/emergency communication devices or other critical systems whose failure to perform be reasonably expected to result in significant injury or loss of life or catastrophic property damage. Accordingly, Supermicro disclaims any and all liability, and should buyer use or sell such products for use in such ultra-hazardous applications, it does so entirely at its own risk. Furthermore, buyer agrees to fully indemnify, defend and hold Supermicro harmless for and against any and all claims, demands, actions, litigation, and proceedings of any kind arising out of or related to such ultra-hazardous use or sale.

Manual Revision 1.2

Release Date: November 20, 2025

Unless you request and receive written permission from Super Micro Computer, Inc., you may not copy any part of this document. Information in this document is subject to change without notice. Other products and companies referred to herein are trademarks or registered trademarks of their respective companies or mark holders.

Copyright © 2025 by Super Micro Computer, Inc.
All rights reserved.

Published in the United States of America

Document Revision History

Date	Revision	Description
11/20/2025	1.2	Updated model number. Updated hardware information.
9/2/2025	1.1	Edited language. Reformatted content for display in web page format.
5/1/2024	1.0	Initial document.

Contents

Chapter 1: Introduction	6
1.1 Product Brief	7
Overview	7
Features and Benefits	8
Multiple Interfaces	8
Networking Protocols	8
ACL	8
QoS	8
MPLS Ready	8
1.2 Description of Hardware	9
Front Panel	9
Back Panel	9
Console Port Description	10
1.3 Status LEDs	11
1.4 Port Description	13
1.5 Power Supply Module	14
1.6 Fan Module	15
1.7 System Specifications	16
Chapter 2: Installation Notice	17
2.1 Switch Installation Notice	18
2.2 Environmental Requirements	19
Dust and Particles	19
Temperature and Humidity	20
Power Supply	21
Preventing Electrostatic Discharge Damage	21
Anti-Interference	21
Rack Configuration	22
2.3 Security Warnings	23
Chapter 3: Switch Installation	24
3.1 Installation Preparation	25
3.2 Device Installation	26

Installing the Switch	26
Installing the Switch with Fixed Brackets	26
Installing Power Supply Modules	27
Installing Fans	27
Connecting the Console	27
SFP+/QSFP28 Transceiver Installation	28
Copper Cable/Fiber Cable Connection	28
Installing Copper Cables	28
Installing Fiber Cables	28
Connecting the DAC Cable	29
AC Power Supply Connection	29
Earthing Cable Connection	30
Checking the Switch	30
Contacting Supermicro	31

Chapter 1:

Introduction

This chapter provides a brief outline of the functions and features of the SSE-C4632SB/SRB switch.

1.1 Product Brief	7
Overview	7
Features and Benefits	8
1.2 Description of Hardware	9
Front Panel	9
Back Panel	9
1.3 Status LEDs	11
1.4 Port Description	13
1.5 Power Supply Module	14
1.6 Fan Module	15
1.7 System Specifications	16

1.1 Product Brief

This section provides a hardware overview and briefly describes the main features of the SSE-C4632SB/SRB switch.

Overview	7
Features and Benefits	8

Overview

The SSE-C4632SB/SRB is a high-density, wire-rate, Layer 2 and Layer 3 switch with 32x100G QSFP28 ToR Switch. The SSE-C4632SB/SRB switch uses 100 GbE switching technology.

Note: The SSE-C4632SB/SRB is available in two configurations for different airflow directions: airflow is front-to-rear for the SSE-C4632SB, and rear-to-front for the SSE-C4632SRB.

The SSE-C4632SB/SRB can serve as a distribution layer switch for campus networks, enterprise networks, and IP metropolitan networks, as well as core layer switches for small and medium-sized networks.

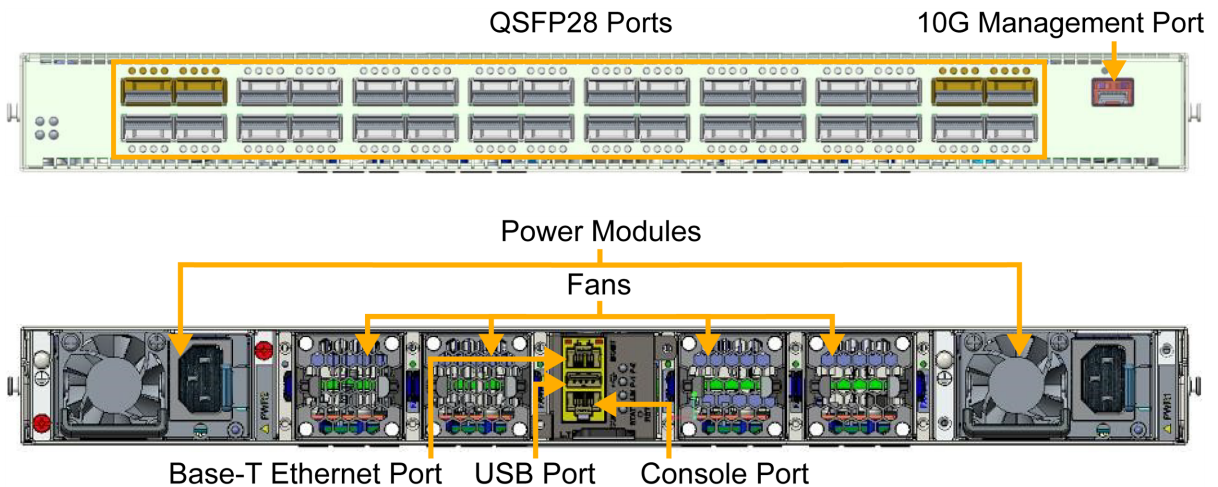

Figure 1-1. Front (Top) and Back (Bottom) Panel of the SSE-C4632SB/SRB

Features and Benefits

Multiple Interfaces

The SSE-C4632SB/SRB switch provides 32 100 Gb QSFP28 ports. Each QSFP28 port can be split into four 25 Gb ports.

Networking Protocols

The SSE-C4632SB/SRB switch supports 802.1d/w/s, 802.1Q, 802.1p, 802.3ad, 802.3x, GVRP, DHCP, and SNTP. The switch comprehensively supports multicast protocols such as IGMP, DVMRP, and PIM. Moreover, the SSE-C4632SB/SRB switch supports RIPv1/2, OSPF, and IPv6. All these protocols enable the SSE-C4632SB/SRB switch to meet the requirements of complex network constructions.

ACL

The SSE-C4632SB/SRB switch supports comprehensive ACL policies. The traffic can be classified by source/destination IP address, source/destination MAC address, IP protocols, TCP/UDP, IP precedence, time ranges, and ToS. Various policies can be conducted to forward the traffic. By implementing ACL policies, users can filter virus packets such as “Worm.Blaster,” “Worm.Sasser,” and “Red Code.” The SSE-C4632SB/SRB switch also supports IEEE802.1x port-based access authentication, which can be deployed with RADIUS, to ensure port-level security and block illegal users.

QoS

The SSE-C4632SB/SRB switch fully supports DiffServ Module. Users can specify a queue bandwidth on each port. WRR/SP/SWRR scheduling is also supported. The SSE-C4632SB/SRB supports port security. Users can deploy trusted CoS, DSCP, IP precedence, and port priority. The user can also modify packets’ DSCP and COS values. The traffic can be classified by port, VLAN, DSCP, IP precedence, and ACL table. Users can also modify packets’ DSCP and IP precedence values. Users can specify different bandwidths for voice/data/video to customize different qualities of service.

MPLS Ready

The SSE-C4632SB/SRB supports MPLS VPN, which can be used in metropolitan area networks and wide area networks, and supports wire speed forwarding. IPv6 and MPLS implement high-performance wire speed forwarding at the same time.

The SSE-C4632SB/SRB supports LDP function and MPLS VPN (it can access the public network), and it can be deployed as PE and P.

1.2 Description of Hardware

This section provides a description of the SSE-C4632SB/SRB switch hardware.

Front Panel	9
Back Panel	9

Front Panel

The following figure and table describe the ports on the front panel of the SSE-C4632SB/SRB switch.

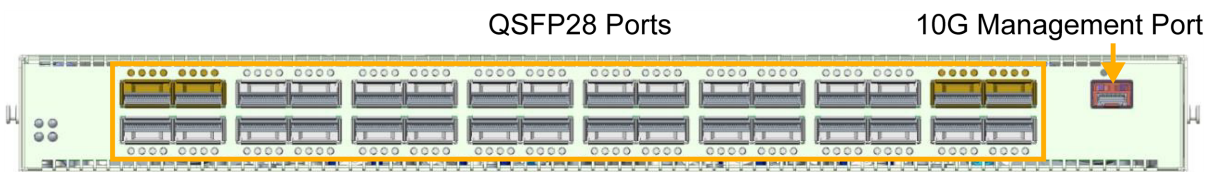

Figure 1-2. Front Panel of the SSE-C4632SB/SRB

Front Panel Features of the SSE-C4632SB/SRB Switch	
QSFP28 Ports	10G Management Port
32	1

Back Panel

The back panel of the SSE-C4632SB/SRB switch features two 220 V redundant power modules and four fans.

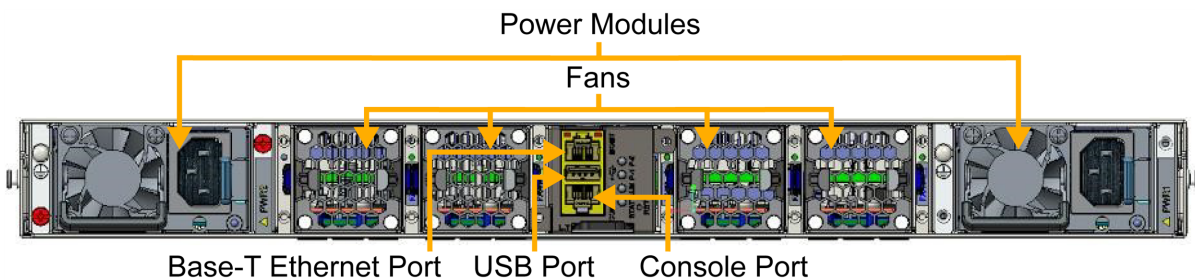

Figure 1-3. Back Panel of the SSE-C4632SB/SRB

Back Panel Features of the SSE-C4632SB/SRB Switch				
Power Modules	Fans	10/100/1000 M Base-T Ethernet port	Console Port	USB 2.0 Interface
2	4	1	1	1

Console Port Description

The SSE-C4632SB/SRB features an RJ45 serial console port. The user can perform local and telnet configuration through this port. The console port supports asynchronous mode. Set the data bit to 8, the stop bit to 1, the parity bit to none, and the default baud rate to 115200 bps.

1.3 Status LEDs

Front Panel LEDs			
Indicator LED	Front Panel Sign	Status	Description
Alarm LED	ALM	Green on	No alarm
System LED	STAT	Amber on	Critical alarm
		Amber blinking	Major alarm: 4 Hz blinking Minor alarm: 1 Hz blinking
		Green and amber alternate blinking at 4 Hz	Default
		For ONIE-installed systems, after ONIE boot success, ONIE sets the LED to green and amber LED alternate blinking at 1 Hz. For ICOS-installed systems, the System Status LED is controlled by ICOS, and the behavior is TBD. The LED controlling is open to NOS, and NOS can control the LED behavior depending on requirement.	
QSFP28 Port Indicator LED	N/A	First green blinking	The port and link are active in 100 GbE mode, and there is link activity.
		First green on steadily	The port and link are active in 100 GbE mode, but there is no link activity.
		All amber blinking	The port and link are active in 4x10 GbE mode, and there is link activity.
		All amber on steadily	The port and link are active in 4x10 GbE mode, but there is no link activity.
		All green blinking	The port and link are active in 4x25 GbE mode, and there is link activity.
		All green on steadily	The port and link are active in 4x25 GbE mode, but there is no link activity.
		Off	The port is not active.

Front Panel LEDs			
Indicator LED	Front Panel Sign	Status	Description
SFP+ Port Indicator LED	N/A	Green blinking	The port and link are active in 10 GbE mode, and there is link activity.
		Green on steadily	The port and link are active in 10 GbE mode, but there is no link activity.
		Amber blinking	The port and link are active in 1 GbE mode, and there is link activity.
		Amber on steadily	The port and link are active in 1 GbE mode, but there is no link activity.

Back Panel LEDs			
Indicator LED	Back Panel Sign	Status	Description
Fan Module Indicator LED	FAN1/FAN2/ FAN3/FAN4	Green on	Fan is present and its status is normal
		Amber on	Fan is present but its status is Alarm
		Off	Fan tray is missing
PSU LED	P1/P2	Green on	PSU is present and its status is normal
		Amber on	PSU is present but its status is incorrect
		Off	PSU is missing
Ethernet Port Activity LED (Left)	N/A	Green blinking	The port is transmitting data
		Off	There is no data transmitting on this port
Ethernet Port Activity LED (Right)	N/A	On with amber LED	The port is configured at 10M/100M speed
		On with green LED	The port is configured at 1000M speed
		Off	No connections, or failing to connect

1.4 Port Description

SSE-C4632SB/SRB Port Description	
Port Mode	Specification
RJ45 Port	<ul style="list-style-type: none"> • 10/100/1000 Mbps auto-negotiation • MDI/MDI-X cable mode auto-negotiation
QSFP28	<ul style="list-style-type: none"> • Supports parallel multimode fiber OM3 and OM4 for short-reach applications 100Gbase-SR4 • Supports long-reach optics 100Gbase-LR4 (10 km) over single-mode fiber • Supports copper 100Gbase-CR4 connections: <ul style="list-style-type: none"> • 1 M 30 AWG • 3 M 28 AWG • 5 M 26 AWG • 100G port mode change to 4x25G should not require a switch device reboot • 100G port mode should be used for changing the breakout cable to 4x25G mode
SFP+	<ul style="list-style-type: none"> • Supports parallel multimode fiber OM3 and OM4 for short reach applications 10Gbase-SR4 • Supports long-reach optics 10Gbase-LR4 (10 km) over single-mode fiber • Supports copper 10Gbase-CR4 connections: <ul style="list-style-type: none"> • 1 M 30 AWG • 3 M 28 AWG • 5 M 26 AWG • 7 M 24 AWG

1.5 Power Supply Module

The SSE-C4632SB/SRB switch uses two redundant 550 W power modules in its standard configuration. The standard configuration provides front-to-rear airflow, while the optional configuration includes rear-to-front airflow components.

Note: The SSE-C4632SB/SRB is available in two configurations for different airflow directions: airflow is front-to-rear for the SSE-C4632SB, and rear-to-front for the SSE-C4632SRB.

Important: Do not mix power modules of different airflow directions. The airflow direction of the power supply modules must be the same as that of the fan modules.

The maximum power is 550 W, the input is 90–264 VAC, and the output is 12 V +/- 5%. There is a fan and a handle on the back of the power supply for inserting or removing the module. The power supply module supports hot-plug.

1.6 Fan Module

The SSE-C4632SB/SRB switch uses four fan modules in its standard configuration. The standard configuration provides front-to-rear airflow, while the optional configuration includes rear-to-front airflow components. The rotating speed of the fan adjusts depending on the system temperature.

Note: The SSE-C4632SB/SRB is available in two configurations for different airflow directions: airflow is front-to-rear for the SSE-C4632SB, and rear-to-front for the SSE-C4632SRB.

Important: Do not mix fan modules of different airflow directions. The airflow direction of the fan modules must be the same as that of the power supply modules.

1.7 System Specifications

System Specifications of the SSE-C4632SB/SRB	
Attribute	Specification
Dimensions	433.8 x 44 x 520 mm (WxHxD)
Weight	10 kg
Fixed ports	32 QSFP28 ports and one SFP+ port
Management ports	Two RJ45 serial console ports
Power input	90–264 VAC (50–60 Hz), 3.4–7.1 A
System consumption	<500 W
Operating temperature	0°C to 45°C
Storage temperature	-40°C to 70°C
Operating relative humidity	10–90%, non-condensing
Storage relative humidity	5–95%, non-condensing

Chapter 2:

Installation Notice

To ensure proper operation of the SSE-C4632SB/SRB switch and physical security, carefully read the following installation guide.

2.1 Switch Installation Notice	18
2.2 Environmental Requirements	19
Dust and Particles	19
Temperature and Humidity	20
Power Supply	21
Preventing Electrostatic Discharge Damage	21
Anti-Interference	21
Rack Configuration	22
2.3 Security Warnings	23

2.1 Switch Installation Notice

Read through these installation instructions carefully before installing the SSE-C4632SB/SRB switch. Make sure that the installation site, as well as all installation materials and tools, are well-prepared.

- During installation, you must use the brackets and screws provided in the accessory kit. You must use the proper tools to perform the installation. You must always wear an antistatic uniform and ESD wrist straps. You must use standard cables and connectors.
- After installation, you must clean the site. Before powering on the switch, you must ensure the switch is well-grounded. You must maintain the switch regularly to extend its lifespan.
- In the event that power input needs to be removed, a readily accessible disconnect device should be incorporated in the building wiring installation.
- Do not block or cover the openings of the switch. Never place a product near a radiator or heat register. Failure to follow these guidelines can cause overheating and affect the reliability of the switch.
- You must remove the cover of your switch to add cards, memory, or internal storage devices. Be sure to replace the cover before powering on your switch.

Important: Do not operate products without the cover in place. Failure to take this precaution may result in personal injury and switch damage.

Important: There is danger of explosion if batteries are mishandled or incorrectly replaced. On a switch with replaceable batteries, replace only with batteries of the same manufacturer and type (or equivalent type recommended by the manufacturer) per the instructions provided in the product service manual. Do not disassemble batteries or attempt to recharge them outside the switch.

Important: Do not dispose of batteries in fire. Dispose of batteries properly in accordance with the manufacturer's instructions and local regulations. Note that on some CPU boards, there is a lithium battery molded into the real-time clock. These batteries are not customer-replaceable parts.

2.2 Environmental Requirements

- The switch must be installed in a clean area. Otherwise, the switch might be damaged by electrostatic adherence.
- Maintain the airflow temperature within 0°C to 40°C and the humidity within 5% to 85% (non-condensing).
- The switch must be put in a dry and cool place. Leave sufficient spacing around the switch for good air circulation.
- The switch must work in the AC power input range of 100–240 VAC (50/60 Hz).
- The switch must be well-grounded in order to avoid ESD damage and physical injury to people.
- The switch must avoid direct sunlight exposure. Keep the switch away from heat sources and strong electromagnetic interference sources.
- The switch must be mounted to a standard 19-inch rack or placed on a clean and level desktop.

Dust and Particles	19
Temperature and Humidity	20
Power Supply	21
Preventing Electrostatic Discharge Damage	21
Anti-Interference	21
Rack Configuration	22

Dust and Particles

Dust is harmful to the safe operation of the SSE-C4632SB/SRB switch. Dust can lead to electrostatic adherence, especially likely under low relative humidity, causing poor contact of metal connectors or contacts. Electrostatic adherence will result in not only a reduced product lifespan, but will also increase the chance of communication failures. The table below lists the recommended values for dust content and particle diameter at the switch operation site.

Environmental Requirements: Dust				
Max Diameter (µm)	0.5	1	3	5
Max Density (particles/m ³)	1.4 x 10 ⁵	7 x 10 ⁵	2.4 x 10 ⁵	1.3 x 10 ⁵

In addition, salt, acid, and sulfide in the air are also harmful to the switch. Such harmful gases aggravate metal corrosion and the aging of some parts. The site must avoid harmful gases, such as SO₂, H₂S, NO₂, NH₃, etc. The table below lists the threshold values.

Environmental Requirements: Particles		
Gas	Average (mg/m ³)	Max (mg/m ³)
SO ₂	0.2	1.5
H ₂ S	0.006	0.03
NO ₂	0.04	0.15
NH ₃	0.05	0.15

Temperature and Humidity

Although the SSE-C4632SB/SRB switch is designed to use four fans, the site must still maintain a desirable temperature and humidity.

High humidity can cause electrical resistance degradation and even electrical leakage. High humidity can also cause the degradation of mechanical properties and corrosion of internal components. Extremely low relative humidity may cause the insulation spacer to contract, which can unsecure the fastening screw. Furthermore, in dry environments, static electricity can be generated and cause harm to internal circuits. Extreme temperatures can cause reduced reliability and premature aging of insulation materials, thus reducing the working lifespan of the switch. In hot summers, it is recommended to use air conditioners to cool down the site. In cold winters, it is recommended to use heaters.

Important: A sample of ambient temperature and humidity must be taken at 1.5 m above the floor and 0.4 m in front of the switch rack, with no protective panel covering the front and back of the rack. Short-term working conditions refer to a maximum of 48 hours of continued operation and an annual cumulative total of less than 15 days. Formidable operation conditions refer to the ambient temperature and relative humidity value that may occur during an air-conditioning system failure, and normal operation conditions must be recovered within five hours.

Environmental Requirements: Temperature and Humidity	
Temperature	Relative Humidity (Non-Condensing)
0°C to 40°C	5% to 85%

Power Supply

Before powering on the power supply of the SSE-C4632SB/SRB, check the power input to ensure proper grounding of the power supply system. The input source for the switch must be reliable and secure; if necessary, a voltage adapter can be used. The building's circuit protection system must include in the circuit a fuse or circuit breaker of no greater than 240 V and 12.5 A. It is recommended to use a UPS for a more reliable power supply.

Important: Improper power supply system grounding, extreme fluctuation of the input source, and transients (or spikes) can result in an increased error rate or hardware damage. This product might come with more than one power cord. Disconnect power supply cords before servicing.

Preventing Electrostatic Discharge Damage

Static electric discharges can cause damage to internal circuits or to the entire SSE-C4632SB/SRB switch. Follow these guidelines for avoiding electrostatic discharge (ESD) damage to the switch:

- Ensure proper earth grounding of the device.
- Perform regular cleaning to reduce dust.
- Maintain proper temperature and humidity.
- Whenever in contact with circuit boards, wear an ESD wrist strap and antistatic uniform.

Anti-Interference

All sources of interference, whether from the SSE-C4632SB/SRB switch itself or the outside environment, will affect operations in various ways; this includes capacitive coupling, inductive coupling, electromagnetic radiation, common impedance (including the grounding system), and cables/lines (power cables, signal lines, and output lines). Note the following points:

- Take precautions to prevent power source interruptions.
- Provide the system with dedicated grounding, rather than sharing the grounding with electronic equipment or lightning protection devices.
- Keep away from high-power radio transmitters, radar transmitters, and high-frequency strong circuit devices.
- Provide electromagnetic shielding, if necessary.

Rack Configuration

The dimensions of the SSE-C4632SB/SRB switch are designed to be mounted on a standard 19-inch rack; ensure good ventilation for the rack and all equipment in it.

- **Elevated operating ambient:** If installed in a closed or multi-unit rack assembly, the operating ambient temperature of the rack environment might be greater than the room ambient. Therefore, be sure to install the equipment in an environment compatible with the maximum ambient temperature (TMA) specified by the manufacturer.
- **Reduced air flow:** Install the equipment in the rack so as not to compromise the amount of airflow required for safe operation of the equipment.
- **Mechanical loading:** Mount the equipment in the rack so as not to achieve a hazardous condition due to uneven mechanical loading.
- **Circuit overloading:** Consider the connection of the equipment to the supply circuit, and the effect that overloading of the circuits might have on overcurrent protection and supply wiring. Be sure of the appropriate equipment nameplate ratings when addressing the potential for circuit overloading.
- **Reliable earthing:** Maintain the reliable earthing of all rack-mounted equipment. Pay particular attention to supplying connections other than direct connections to the branch circuit (for example, the use of any power strips).

2.3 Security Warnings

- When using the SFP/SFP+/QSFP/SFP28/QSFP28 transceiver, do not stare directly at the fiber bore when the switch is in operation. Otherwise, the laser might harm your eyes.
- Do not attempt to conduct operations which can damage the switch or cause physical injury.
- Do not install, move, or open the switch and its modules when the switch is in operation.
- Do not open the shell of the switch.
- Do not drop metals into the switch; this can cause a short circuit.
- Do not touch the power plug or the power socket.
- Do not place flammable materials near the switch.
- Do not configure the switch alone in a hazardous situation.
- Use standard power sockets which have overload and leakage protection.
- Regularly inspect and maintain the site and the switch.
- Have an emergency power switch on the site. In case of emergency, turn off the power immediately.

Important: Potential risks include electric leakage, power supply arcing, power line breakage, imperfect earth, overloaded circuits, and electrical short circuits. If electric shock, fire, or an electrical short circuit occurs, cut off the electricity supply and rapidly turn on the alarm. As long as the area is safe to do so without further harm to others or yourself, rescue the injured person. Give the injured person proper first aid treatment for the injury and seek urgent medical assistance.

Chapter 3:

Switch Installation

Read the following content for details on installing the SSE-C4632SB/SRB switch.

3.1 Installation Preparation	25
3.2 Device Installation	26
Installing the Switch	26
Installing Power Supply Modules	27
Installing Fans	27
Connecting the Console	27
SFP+/QSFP28 Transceiver Installation	28
Copper Cable/Fiber Cable Connection	28
AC Power Supply Connection	29
Earthing Cable Connection	30
Checking the Switch	30

3.1 Installation Preparation

Carefully unpack the SSE-C4632SB/SRB switch shipping package and verify all the contents inside.

The following additional tools and utilities are required for setup:

- Phillips screwdriver
- Flathead screwdriver
- ESD wrist strap
- Antistatic uniform

Note: These required tools and utilities are not included in the package.

3.2 Device Installation

This section provides rack and component installation information for the SSE-C4632SB/SRB switch.

Installing the Switch	26
Installing Power Supply Modules	27
Installing Fans	27
Connecting the Console	27
SFP+/QSFP28 Transceiver Installation	28
Copper Cable/Fiber Cable Connection	28
AC Power Supply Connection	29
Earthing Cable Connection	30
Checking the Switch	30

Installing the Switch

The SSE-C4632SB/SRB switch supports mounting via fixed bracket onto a standard 19-inch rack.

Important: Given the weight of the SSE-C4632SB/SRB, at least one other person must assist during installation or removal.

Important: The brackets are used to secure the switch to the rack. They cannot serve as a bearing. Place a rack shelf under the switch. Do not place anything on top of the switch. Do not block the ventilation on the switch to ensure the proper operation of the switch.

Note: Images displayed are for illustrative purposes only. The components installed in your system may or may not look exactly the same as the graphics shown in the manual.

Installing the Switch with Fixed Brackets

Fixed brackets enable mounting the switch onto the rack.

1. Attach the two brackets onto the switch with screws provided in the accessory kit.
2. Choose a location at the bottom of the rack.
3. Slide the bracket-mounted switch smoothly into the rack, fastening it to the rack with the screws provided. Leave enough space around the switch for good air circulation.

Installing Power Supply Modules

The SSE-C4632SB/SRB uses two power supplies. For details, refer to ["Power Supply Module" on page 14](#).

1. With the correct side of the power supply module facing up, and its handle pointing away from the switch, push the module into the power bay of the switch until it clicks.
2. To remove the power supply module, push the release tab on the module, then pull the module out using the handle provided.

Installing Fans

The SSE-C4632SB/SRB switch uses four fans. For details, refer to ["Fan Module" on page 15](#).

Important: Hazardous moving parts. Keep away from moving fan blades. The fans might still be turning when you remove the fan assembly from the switch. Keep fingers, screwdrivers, and other objects away from the openings in the fan assembly's housing. The sheet metal edge of the fan is thin. Be careful of injury to the hands when pinching, pressing, inserting, or removing it.

1. With the correct side of the fan module facing up, and its handles pointing away from the switch, push the module into the fan slot of the switch until it clicks.
2. To remove the fan module, push the release tabs on the module, then pull the module out using the handles provided.

Connecting the Console

1. Find the console cable provided in the accessory kit. Attach the console cable end to the console port of the switch.
2. Connect the other end of the console cable to a character terminal (PC).
3. Power on the switch and the character terminal.
4. Configure the switch through the character terminal.

SFP+/QSFP28 Transceiver Installation

The SSE-C4632SB/SRB provides one SFP+ and 32 QSFP28 ports.

Important: Do not stare directly at the two-fiber bore in the QSFP28 transceiver when the switch is in operation; the laser might harm your eyes.

Note: The optical transceiver is hot-swappable.

1. Put on an ESD wrist strap (or antistatic gloves).
2. Insert the transceiver into the guide rail inside the data port. Do not install the transceiver upside down.
3. Gently push the transceiver along the guide rail until you feel the transceiver snap into place at the bottom of the data port.

Copper Cable/Fiber Cable Connection

Installing Copper Cables

Important: Verify the sign above the port to ensure you are using the right port. Connecting to the wrong ports might damage the switch.

1. Insert one end of the Ethernet cable into the RJ45 Ethernet port in the switch copper port.
2. Insert the other end of the Ethernet cable into the RJ45 Ethernet port of another device.
3. Check all status indicators for the corresponding ports. A lit LED indicates that the link has been established; otherwise, the link is not ready and the cable should be examined.

Installing Fiber Cables

Important: Verify the sign above the port to ensure you are using the correct ports. Connecting to the wrong ports might damage the transceiver or the other ports. When connecting other devices through a fiber cable to the switch, the output power of the fiber cable must not exceed the maximum received power of the corresponding modules. Otherwise, it will damage the fiber transceiver.

Important: Do not stare directly at the two-fiber bore in the QSFP28 transceiver when the switch is in operation; the laser might harm your eyes.

1. Remove the protective plug from the transceiver bore. Remove the protective cap from one end of the fiber cable. Keep the fiber end clean and neat.
2. Attach one end of the fiber cable to the transceiver, then attach the other end to the transceiver of the corresponding devices.

Note: The transceiver's TX port should be connected to the RX port of the corresponding device, and vice versa.

3. Check the fiber port status indicator. A lit LED indicates that the link has been established; otherwise, the link is not ready and must be examined.

Connecting the DAC Cable

1. Connect the two sides of the DAC cable to the SFP+/QSFP28 transceiver of the SSE-C4632SB/SRB switch.
2. Check the indicator light state of the light port.
 - If the LINK light is on, it means the link is connected.
 - If the LINK light is off, it means the lines have trouble and you must check the line connection.

AC Power Supply Connection

The SSE-C4632SB/SRB switch uses 220 VAC power supplies. For detailed information, read the power input specification.

Important: The input voltage must be within the required range; otherwise, the switch could be damaged or malfunction. Do not open the switch shell without permission; this can cause physical injury. Disconnect all power supply cords before servicing.

1. Insert one end of the power cable provided in the accessory kit into the power source socket, and the other end into the power reception socket of the switch (with overload and leakage protection).
2. Check the power status indicator on the front panel of the switch. The corresponding PWR indicator should light up. The SSE-C4632SB/SRB is self-adjustable for the input voltage. As soon as the input voltage is in the range printed on the switch surface, the switch can operate correctly.
3. Once powered on, the switch executes a self-test procedure and starts up.

Earthing Cable Connection

Important: The unit shall be permanently connected to earth.

1. Attach one end of the earthing cable to the earthing pillar of the back panel.
2. Attach the nut on the earthing pillar of the switch with the screws fixed on its chassis.
3. Connect the other end of the earthing cable to the earthing side.

Checking the Switch

After installing the SSE-C4632SB/SRB switch, run the following checks:

- Check whether the ground cable is connected.
- Check whether the console cable connects correctly to the power cable.
- If there are cables outdoors, ensure the cable is well-connected with lightning protection devices.

Contacting Supermicro

Headquarters

Address: Super Micro Computer, Inc.
980 Rock Ave.
San Jose, CA 95131 U.S.A.

Tel: +1 (408) 503-8000

Fax: +1 (408) 503-8008

Email: Marketing@supermicro.com (General Information)
Sales-USA@supermicro.com (Sales Inquiries)
Government_Sales-USA@supermicro.com (Gov. Sales Inquiries)
Support@supermicro.com (Technical Support)
RMA@Supermicro.com (RMA Support)
Webmaster@supermicro.com (Webmaster)

Website: <https://www.supermicro.com>

Europe

Address: Super Micro Computer B.V.
Het Sterrenbeeld 28, 5215 ML
's-Hertogenbosch, The Netherlands

Tel: +31 (0) 73-6400390

Fax: +31 (0) 73-6416525

Email: Sales_Europe@supermicro.com (Sales Inquiries)
Support_Europe@supermicro.com (Technical Support)
RMA_Europe@supermicro.com (RMA Support)

Website: <https://www.supermicro.nl>

Asia-Pacific

Address: Super Micro Computer, Inc.
3F, No. 150, Jian 1st Rd.
Zhonghe Dist., New Taipei City 235 Taiwan (R.O.C)

Tel: +886 (2) 8226-3990

Fax: +886 (2) 8226-3992

Email: Sales-Asia@supermicro.com.tw (Sales Inquiries)
Support@supermicro.com.tw (Technical Support)
RMA@supermicro.com.tw (RMA Support)

Website: <https://www.supermicro.com.tw>