

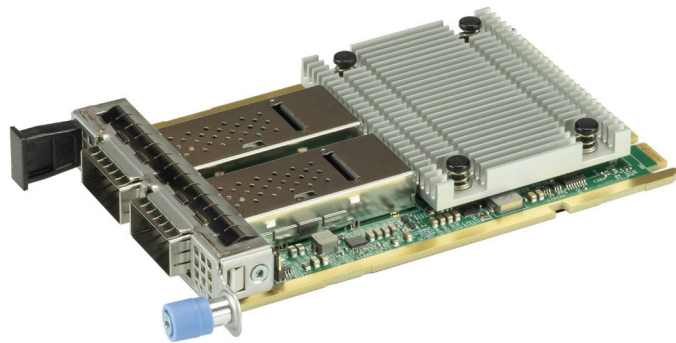

AOC-A100G-m2CM

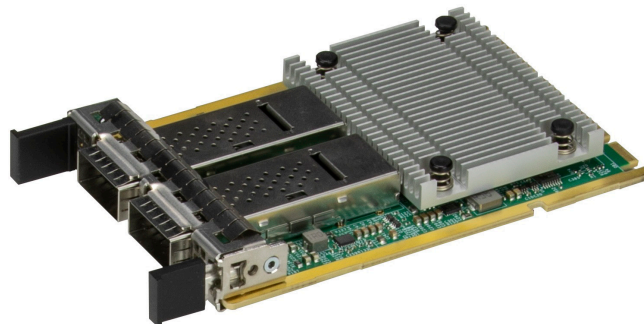

AOC-A100G-m2CG



USER'S MANUAL

Revision 1.1a

The information in this user's manual has been carefully reviewed and is believed to be accurate. The manufacturer assumes no responsibility for any inaccuracies that may be contained in this document, and makes no commitment to update or to keep current the information in this manual, or to notify any person or organization of the updates. **Please Note: For the most up-to-date version of this manual, please see our website at [www.supermicro.com](http://www.supermicro.com).**

Super Micro Computer, Inc. ("Supermicro") reserves the right to make changes to the product described in this manual at any time and without notice. This product, including software and documentation, is the property of Supermicro and/or its licensors, and is supplied only under a license. Any use or reproduction of this product is not allowed, except as expressly permitted by the terms of said license.

IN NO EVENT WILL Super Micro Computer, Inc. BE LIABLE FOR DIRECT, INDIRECT, SPECIAL, INCIDENTAL, SPECULATIVE OR CONSEQUENTIAL DAMAGES ARISING FROM THE USE OR INABILITY TO USE THIS PRODUCT OR DOCUMENTATION, EVEN IF ADVISED OF THE POSSIBILITY OF SUCH DAMAGES. IN PARTICULAR, SUPER MICRO COMPUTER, INC. SHALL NOT HAVE LIABILITY FOR ANY HARDWARE, SOFTWARE, OR DATA STORED OR USED WITH THE PRODUCT, INCLUDING THE COSTS OF REPAIRING, REPLACING, INTEGRATING, INSTALLING OR RECOVERING SUCH HARDWARE, SOFTWARE, OR DATA.

Any disputes arising between manufacturer and customer shall be governed by the laws of Santa Clara County in the State of California, USA. The State of California, County of Santa Clara shall be the exclusive venue for the resolution of any such disputes. Supermicro's total liability for all claims will not exceed the price paid for the hardware product.

FCC Statement: This equipment has been tested and found to comply with the limits for a Class A digital device pursuant to Part 15 of the FCC Rules. These limits are designed to provide reasonable protection against harmful interference when the equipment is operated in industrial environment. This equipment generates, uses, and can radiate radio frequency energy and, if not installed and used in accordance with the manufacturer's instruction manual, may cause harmful interference with radio communications. Operation of this equipment in a residential area is likely to cause harmful interference, in which case you will be required to correct the interference at your own expense.

California Best Management Practices Regulations for Perchlorate Materials: This Perchlorate warning applies only to products containing CR (Manganese Dioxide) Lithium coin cells. "Perchlorate Material-special handling may apply. See [www.dtsc.ca.gov/hazardouswaste/perchlorate](http://www.dtsc.ca.gov/hazardouswaste/perchlorate)."



**WARNING:** This product can expose you to chemicals including lead, known to the State of California to cause cancer and birth defects or other reproductive harm. For more information, go to [www.P65Warnings.ca.gov](http://www.P65Warnings.ca.gov).

The products sold by Supermicro are not intended for and will not be used in life support systems, medical equipment, nuclear facilities or systems, aircraft, aircraft devices, aircraft/emergency communication devices or other critical systems whose failure to perform be reasonably expected to result in significant injury or loss of life or catastrophic property damage. Accordingly, Supermicro disclaims any and all liability, and should buyer use or sell such products for use in such ultra-hazardous applications, it does so entirely at its own risk. Furthermore, buyer agrees to fully indemnify, defend and hold Supermicro harmless for and against any and all claims, demands, actions, litigation, and proceedings of any kind arising out of or related to such ultra-hazardous use or sale.

Manual Revision 1.1a

Release Date: December 09, 2025

Unless you request and receive written permission from Super Micro Computer, Inc., you may not copy any part of this document. Information in this document is subject to change without notice. Other products and companies referred to herein are trademarks or registered trademarks of their respective companies or mark holders.

Copyright © 2025 by Super Micro Computer, Inc.  
All rights reserved.

**Printed in the United States of America**

# Preface

## About This Manual

This user's guide is written for system integrators, IT technicians, and knowledgeable end users. It provides information for the installation and use of the AOC-A100G-m2CM/-m2CG add-on card.

## About This Add-On Card

Supermicro® Advanced I/O Modules (AIOM) are the latest form factor designed to provide a wide range of networking options to support the most advanced I/O technologies. The AOC-A100G-m2CM/-m2CG is one of the most feature-rich and low-power consumption 100 GbE controllers in the market. Based on the Mellanox® ConnectX-6 Dx controller with features such as VXLAN, NVGRE, and RDMA, it provides unparalleled density, performance, and functionality. The Supermicro AOC-A100G-m2CM/-m2CG is the industry's most secure and advanced cloud network interface card to accelerate mission-critical data center applications, such as security, virtualization, SDN/NFV, big data, machine learning, and storage.

## An Important Note to the User

All graphic images and layout drawings shown in this user's guide are based upon the latest PCB revision available at the time of publishing this user's guide. The add-on card you have received may or may not look exactly the same as the graphics shown in this user's guide.

## Returning Merchandise for Service

A receipt or copy of your invoice marked with the date of purchase is required before any warranty service will be rendered. You can obtain service by calling your vendor for a Returned Merchandise Authorization (RMA) number. When returning to the manufacturer, the RMA number should be prominently displayed on the outside of the shipping carton and mailed prepaid or hand-carried. Shipping and handling charges will be applied for all orders that must be mailed when service is complete. For faster service, RMA authorizations may be requested online (<http://www.supermicro.com/support/rma/>).

This warranty only covers normal consumer use and does not cover damages incurred in shipping or from failure due to the alteration, misuse, abuse, or improper maintenance of products.

During the warranty period, contact your distributor first for any product problems.

## Conventions Used in the Manual

Special attention should be given to the following symbols for proper installation and to prevent damage done to the components or injury.



**Warning!** Indicates important information given to prevent equipment/property damage or personal injury.



**Warning!** Indicates high voltage may be encountered while performing a procedure.



**Important:** Important information given to ensure proper system installation or to relay safety precautions.



**Note:** Additional information given to differentiate various models or to provide information for proper system setup.

## Important Links

For your system to work properly, follow the links to download all necessary drivers/utilities and the user's manual for your server.

- Supermicro product manuals: <http://www.supermicro.com/support/manuals/>
- Product drivers and utilities: <https://www.supermicro.com/wdl/driver>
- Product safety info: <https://www.supermicro.com/en/about/policies/safety-information>
- A secure data deletion tool designed to fully erase all data from storage devices can be found at our website: [https://www.supermicro.com/about/policies/disclaimer.cfm?url=/wdl/utility/Lot9\\_Secure\\_Data\\_Deletion\\_Utility/](https://www.supermicro.com/about/policies/disclaimer.cfm?url=/wdl/utility/Lot9_Secure_Data_Deletion_Utility/)
- If you have any questions, contact our support team at: [support@supermicro.com](mailto:support@supermicro.com)
- Frequently Asked Questions: <https://www.supermicro.com/FAQ/index.php>
- If you have any feedback on Supermicro product manuals, contact our writing team at: [Techwriterteam@supermicro.com](mailto:Techwriterteam@supermicro.com)

This manual may be periodically updated without notice. Check the Supermicro website for possible updates to the manual revision level.

## Naming Convention

### AOC-ATG-i2T2SM

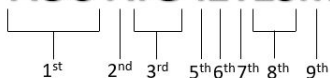

| Character | Representation                                       | Options   |
|-----------|--|---|
| 1st       | Product Family                                       | AOC: Add On Card  |
| 2nd       | Form Factor  | S: Standard, P: Proprietary, C: MicroLP,<br>M: Super IO Module (SIOM), MH: SIOM Hybrid<br>A: Advanced IO Module (AIOM), AH: AIOM Hybrid   |
| 3rd       | Product Type/Speed                                   | G: GbE (1Gb/s), TG: 10GbE (10Gb/s), 25G: 25GbE (25Gb/s), 40G: 40GbE (40Gb/s), 50G: 50GbE (50Gb/s), 100G: 100GbE (100Gb/s), IBE: EDR IB (100Gb/s), HFI: Host Fabric Interface                          |
| 4th       | Chipset Model (Optional)                             | N: Niantec (82599), P: Powerville (i350), S: Sageville (X550),<br>F: Fortville (XL710/X710), L: Lewisburg (PCH)   |
| 5th       | Chipset Manufacturer                                 | i: Intel, m: Mellanox, b: Broadcom  |
| 6th       | Number of Ports                                      | 1: 1 port, 2: 2 ports, 4: 4 ports, 8: 8 ports   |
| 7th       | Connector Type (Optional)                            | S: SFP/SFP+/SFP28, T: 10GBase-T, Q: QSFP+, C: QSFP28  |
| 8th       | 2 <sup>nd</sup> Controller/Connector Type (Optional) | G: 1x GbE RJ45, 2G: GbE 2x RJ45, S: 1x 10G SFP+, T: 10GBase-T, 2T: 2x 10GBase-T, 2S: 2x SFP+  |
| 9th       | Bracket  | For SIOM – Non-M: swappable bracket for Storage systems, M: Internal bracket for Twin systems.<br>For AIOM – Non-M: 1U height bracket for Edge systems, M: 0.5U height bracket for all other systems. |

## Contacting Supermicro

### Headquarters

Address: Super Micro Computer, Inc.  
980 Rock Ave.  
San Jose, CA 95131 U.S.A.

Tel: +1 (408) 503-8000

Fax: +1 (408) 503-8008

Email: marketing@supermicro.com (General Information)  
Sales-USA@supermicro.com (Sales Inquiries)  
Government\_Sales-USA@supermicro.com (Gov. Sales Inquiries)  
support@supermicro.com (Technical Support)  
RMA@supermicro.com (RMA Support)  
Webmaster@supermicro.com (Webmaster)

Website: [www.supermicro.com](http://www.supermicro.com)

### Europe

Address: Super Micro Computer B.V.  
Het Sterrenbeeld 28, 5215 ML  
's-Hertogenbosch, The Netherlands

Tel: +31 (0) 73-6400390

Fax: +31 (0) 73-6416525

Email: Sales\_Europe@supermicro.com (Sales Inquiries)  
Support\_Europe@supermicro.com (Technical Support)  
RMA\_Europe@supermicro.com (RMA Support)

Website: [www.supermicro.nl](http://www.supermicro.nl)

### Asia-Pacific

Address: Super Micro Computer, Inc.  
3F, No. 150, Jian 1st Rd.  
Zhonghe Dist., New Taipei City 235  
Taiwan (R.O.C)

Tel: +886-(2) 8226-3990

Fax: +886-(2) 8226-3992

Email: Sales-Asia@supermicro.com.tw (Sales Inquiries)  
Support@supermicro.com.tw (Technical Support)  
RMA@supermicro.com.tw (RMA Support)

Website: [www.supermicro.com.tw](http://www.supermicro.com.tw)

---

---

# Table of Contents

## ***Chapter 1 Introduction***

|                         |    |
|-------------------------|----|
| 1.1 Overview.....       | 8  |
| 1.2 Key Features.....   | 8  |
| 1.3 Specifications..... | 9  |
| 1.4 Available SKUs..... | 11 |

## ***Chapter 2 Hardware Components***

|  |    |
|--|----|
| 2.1 Add-On Card Image and Layout.....            | 12 |
| 2.2 Major Components.....                        | 15 |
| 2.3 QSFP28 Ethernet Connections.....             | 16 |
| 2.4 Port LEDs.....                               | 17 |
| 2.5 Jumper Settings.....                         | 18 |
| 2.6 PCIe 4.0 x16 AIOM Form Factor Connector..... | 19 |

## ***Chapter 3 Installation***

|  |    |
|--|----|
| 3.1 Static-Sensitive Devices.....                        | 20 |
| 3.2 Before Installation.....                             | 21 |
| 3.3 Installing the Add-on Card (with 0.5U Bracket).....  | 22 |
| 3.4 Installing Drivers (for Mellanox ConnectX-6 Dx)..... | 25 |

# Chapter 1

## Introduction

### 1.1 Overview

Congratulations on purchasing your add-on card from an acknowledged leader in the industry. Supermicro products are designed with the utmost attention to detail to provide you with the highest standards of quality and performance. For product support and updates, refer to our website at <https://www.supermicro.com/en/products/networking/adapters>.

### 1.2 Key Features

The key features of this add-on card include the following:

- Advanced I/O Module (AIOM) form factor
- Mellanox ConnectX-6 Dx 100 GbE controller
- Host Interface: PCIe Gen 4.0 x16
- Dual QSFP28 connectors
- PCIe Gen 4.0
- RDMA over Converged Ethernet (RoCE)
- VXLAN, NVGRE, and Geneve
- Asset Management Features with thermal sensor
- Network Controller Sideband Interface (NC-SI) for remote management
- No Crypto

## 1.3 Specifications

### General

- Advanced I/O Module (AIOM) form factor
- Mellanox ConnectX-6 Dx 100 GbE controller
- Dual QSFP28 ports

### Storage Accelerations

- NVMe over Fabric offloads for target
- Storage protocols: iSER, NFSoRDMA
- SMB Direct, NVMe-oF, and more
- T-10 Dif/Signature Handover

### RDMA over Converging Ethernet (RoCE)

- RoCE v1/v2
- Zero-Touch RoCE: no ECN, no PFC
- RoCE over overlay networks
- IPsec over RoCE
- Selective repeat
- Programmable congestion control interface
- GPUDirect®
- Dynamically Connected Transport (DCT)
- Burst buffer offload

## Management and Control

- NC-SI, MCTP over SMBus, and MCTP over PCIe — Baseboard Management Controller interface
- PLDM for Monitor and Control DSP0248
- PLDM for Firmware Update DSP026
- I2C interface for device control and configuration

## Remote Boot

- Remote boot over Ethernet
- Remote boot over iSCSI
- UEFI support for x86 and ARM servers
- PXE boot

## Standards

- IEEE 802.3bs, 200 Gigabit Ethernet
- IEEE 802.3cd, 50, 100, and 200 Gigabit Ethernet
- IEEE 802.3bj, 802.3bm 100 Gigabit Ethernet
- IEEE 802.3by, 25, 50 Gigabit Ethernet supporting all FEC modes
- IEEE 802.3ba 40 Gigabit Ethernet
- IEEE 802.3ae 10 Gigabit Ethernet
- IEEE 802.3az Energy Efficient Ethernet (supports only “FastWake” mode)
- IEEE 802.3ap based autonegotiation and KR startup
- IEEE 802.3ad, 802.1AX Link Aggregation
- IEEE 802.1Q, 802.1P VLAN tags and priority
- IEEE 802.1Qaz (ETS)
- IEEE 802.1Qbb (PFC)

- IEEE 802.1Qbg
- IEEE 1588v2
- 25/50 Ethernet Consortium “Low Latency FEC” for 50 GE/100 GE/200 GE PAM4 links
- PCI Express Gen 3.0 and 4.0

## Power Consumption

- Maximum power consumption: 23.7 W

## Operating Conditions

- Storage temperature: -40°C to 70°C (-40°F to 158°F)
- Storage humidity: 90% non-condensing relative humidity at 35°C (95°F)

## Physical Dimensions

- Card PCB dimensions: 2.99" x 4.53" (76 mm x 115 mm) (W x D)

## 1.4 Available SKUs

| Product Part Number | Bracket Included | Description  |
|---------------------|------------------|--|
| AOC-A100G-m2CM      | BKT-0170L        | 2-port 100 Gigabit Ethernet Adapter with a 0.5U height Pull-Tab bracket                          |
| AOC-A100G-m2CG      | BKT-0205L        | 2-port 100 Gigabit Ethernet Adapter with a 0.5U height narrow bracket for Grand Twin FIO systems |



**Note:** This product is sold only as part of an integrated solution with Supermicro server systems.

## Chapter 2

# Hardware Components

## 2.1 Add-On Card Image and Layout

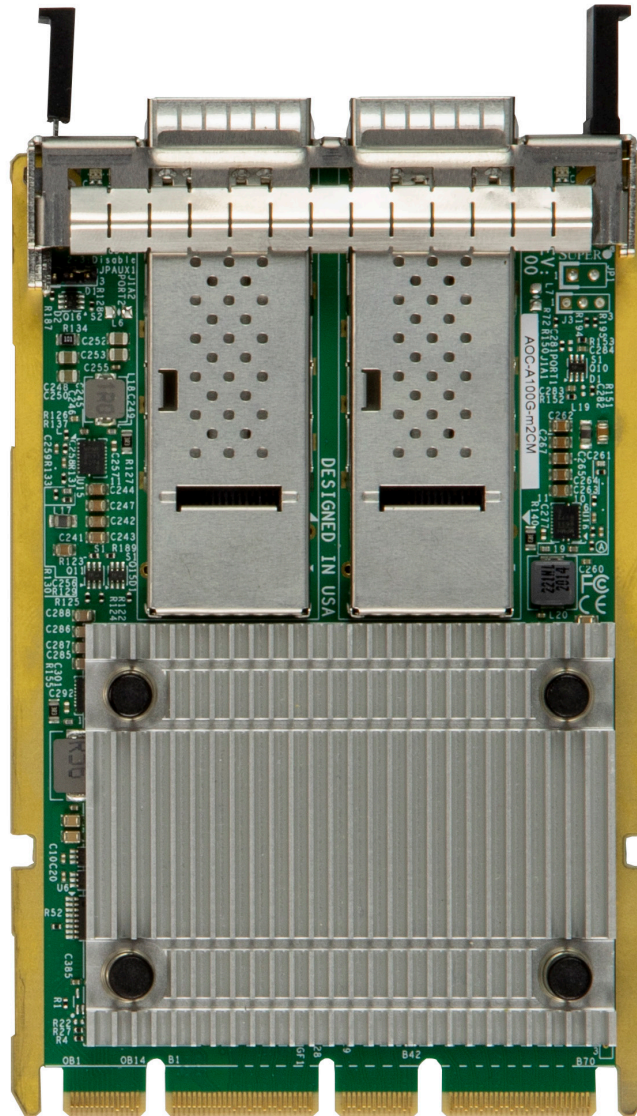
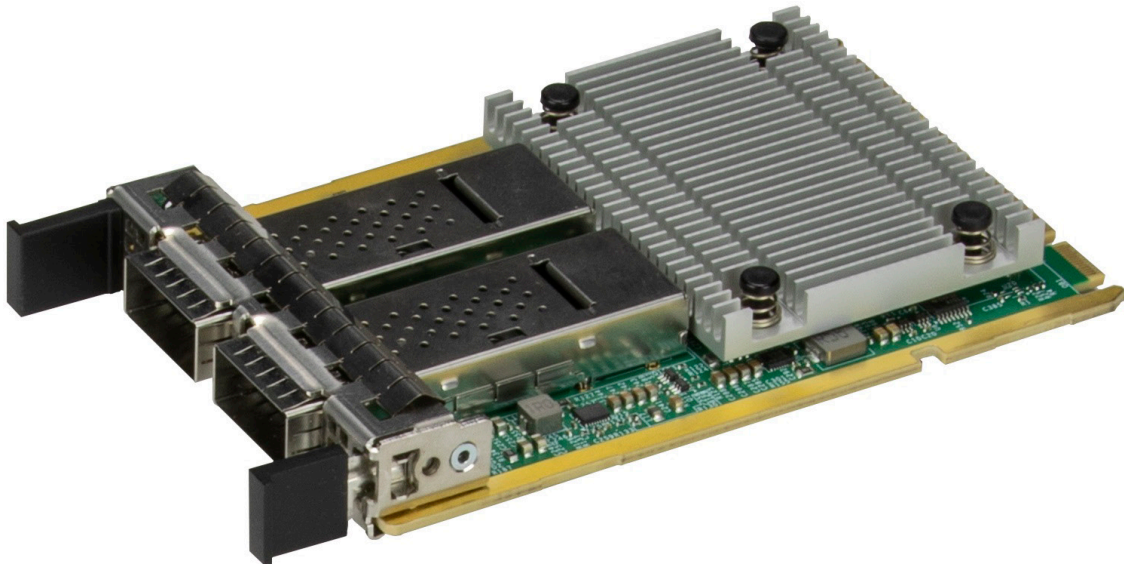

Figure 2-1: AOC-A100G-m2CM Image



**Figure 2-2: AOC-A100G-m2CG Image**

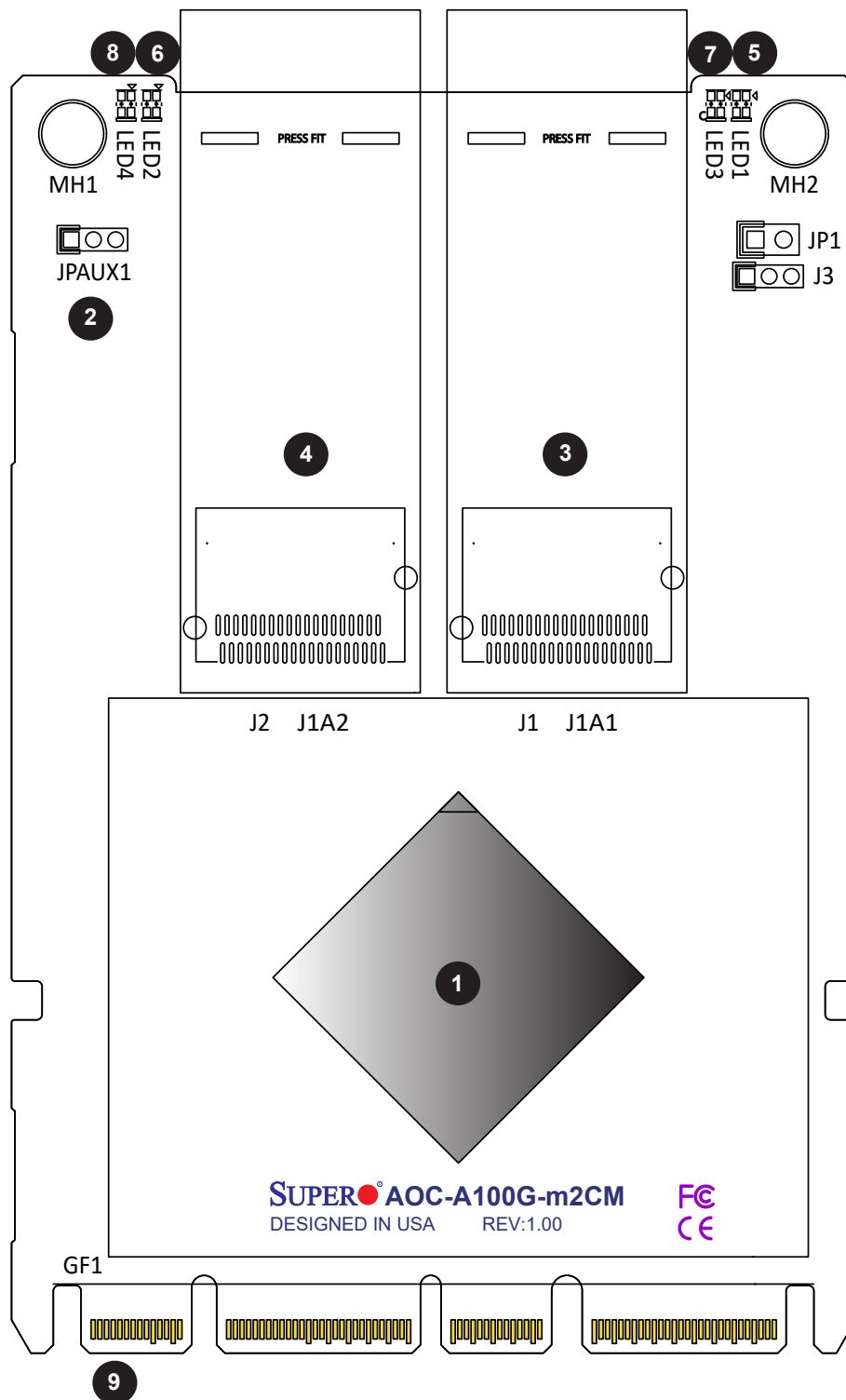

Figure 2-2: AOC-A100G-m2CM Layout

## 2.2 Major Components

The following major components are installed on the AOC-A100G-m2CM/-m2CG:

| <b>AOC-A100G-m2CM/-m2CG Major Components</b> |                        |  |
|--|------------------------|--|
| <b>No</b>                                    | <b>Component Name</b>  | <b>Definition</b>                          |
| 1  | Mellanox ConnectX-6 Dx | 100 GbE controller                         |
| 2  | JPAUX1                 | 1–2: Enable AUX Power                      |
|  |                        | 2–3: Disable AUX Power                     |
| 3  | J1/J1A1                | Quad Small Form-Factor Pluggable 28 Port 1 |
| 4  | J2/J1A2                | Quad Small Form-Factor Pluggable 28 Port 2 |
| 5  | LED1                   | QSFP28 Port 1 Link LED                     |
| 6  | LED2                   | QSFP28 Port 2 Link LED                     |
| 7  | LED3                   | QSFP28 Port 1 Active LED                   |
| 8  | LED4                   | QSFP28 Port 2 Active LED                   |
| 9  | GF1                    | PCIe 4.0 AIOM form factor                  |

## 2.3 QSFP28 Ethernet Connections

### QSFP28 Port

AOC-A100G-m2CM/-m2CG has dual Quad-Small-Form-Factor-Pluggable 28 (QSFP28) connectors located on the add-on card. The QSFP28 ports operate at up to 100 GbE. Plug the Direct Attached Copper (DAC) cable into the QSFP28 ports for network connections. See the layout for the locations.

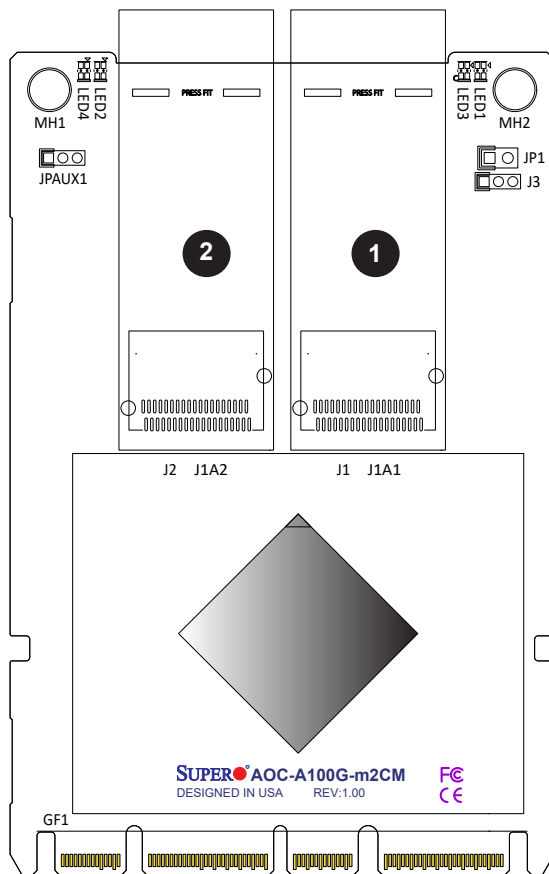

1. QSFP28 Port 1

2. QSFP28 Port 2

## 2.4 Port LEDs

### QSFP28 Port LEDs

There are four LEDs, two LEDs per port, located below the dual QSFP28 ports to indicate the link speed and activity of each port. See the table at right for more information.

| QSFP28 Port LEDs |                |                       |
|------------------|----------------|-----------------------|
| LED              | Color          | Definition            |
| Activity         | Blinking Green | Activity              |
| Link             | Amber          | < 100 Gbps Link Speed |
|                  | Green          | 100 Gbps Link Speed   |

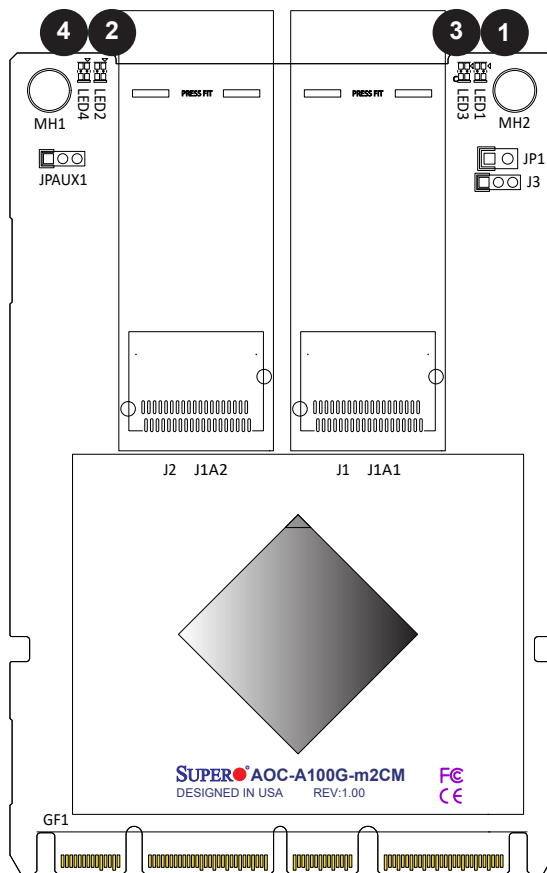

1. QSFP28 Port 1 Link LED
2. QSFP28 Port 2 Link LED
3. QSFP28 Port 1 Active LED
4. QSFP28 Port 2 Active LED

## 2.5 Jumper Settings

### Explanation of Jumpers

To modify the operation of the motherboard, jumpers can be used to choose between optional settings. Jumpers create shorts between two pins to change the function of the connector. Pin 1 is identified with a square solder pad on the printed circuit board.

|                                   |   |                         |                    |
|-----------------------------------|---|-------------------------|--------------------|
| <b>AOC JPAUX1 Set to Disabled</b> | <b>When System/Motherboard Goes Into Standby Mode</b> |                         |                    |
|                                   | <b>IPMI Support</b>                                   | <b>FailOver Support</b> | <b>WoL Support</b> |
|                                   | No  | No                      | No                 |
|                                   | <b>When System/Motherboard Is NOT In Standby Mode</b> |                         |                    |
|                                   | <b>IPMI Support</b>                                   | <b>FailOver Support</b> | <b>WoL Support</b> |
|                                   | Yes   | Yes                     | N/A                |
| <b>AOC JPAUX1 Set to Enabled</b>  | <b>When System/Motherboard Goes Into Standby Mode</b> |                         |                    |
|                                   | <b>IPMI Support</b>                                   | <b>FailOver Support</b> | <b>WoL Support</b> |
|                                   | Yes   | Yes                     | Yes                |
|                                   | <b>When System/Motherboard Is NOT In Standby Mode</b> |                         |                    |
|                                   | <b>IPMI Support</b>                                   | <b>FailOver Support</b> | <b>WoL Support</b> |
|                                   | Yes   | Yes                     | N/A                |

| <b>JPAUX1 for Standby Power</b>               | <b>Function</b>                                   | <b>Notes</b>  |
|---|---|---|
| Disable<br><i>No standby power to AOC NIC</i> | Disable jumper to disconnect the standby power    | Default   |
| Enable<br><i>Standby power to AOC NIC</i>     | Enable jumper to connect standby power to AOC NIC | WoL is supported on port 1 ONLY, but limited to platforms with sufficient airflow when it is in standby mode (S5 state). Consult Supermicro before enabling it. |

## 2.6 PCIe 4.0 x16 AIOM Form Factor Connector

Insert the PCIe 4.0 x16 AIOM form factor connector into a PCIe 4.0 x16 AIOM form factor slot on a motherboard to use this AIOM form factor card. See the layout for the location.

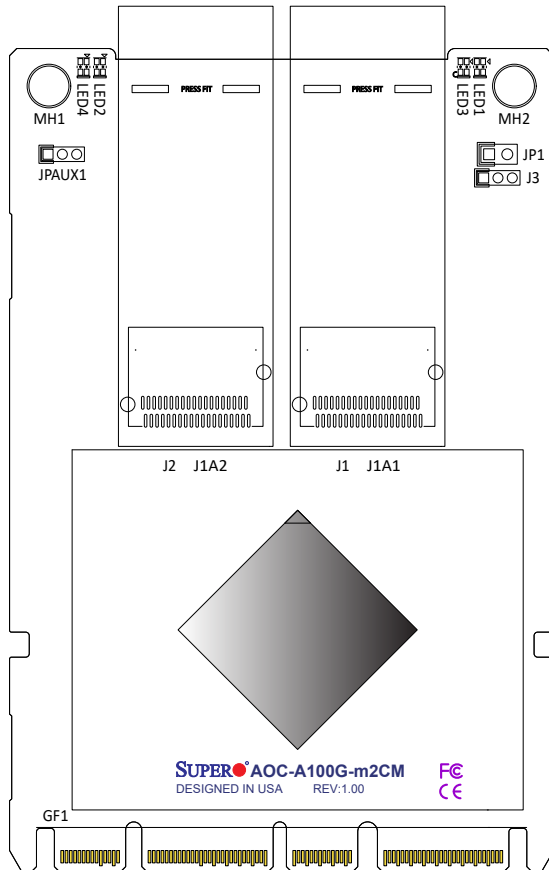

1. PCIe 4.0 x16 AIOM form factor connector

1

## Chapter 3

# Installation

### 3.1 Static-Sensitive Devices

Electrostatic Discharge (ESD) can damage electronic components. To avoid damaging your add-on card, it is important to handle it very carefully. The following measures are generally sufficient to protect your equipment from ESD.

#### Precautions

- Use a grounded wrist strap designed to prevent static discharge.
- Touch a grounded metal object before removing the add-on card from the antistatic bag.
- Handle the add-on card by its edges only; do not touch its components or peripheral chips.
- Put the add-on card back into the antistatic bags when not in use.
- For grounding purposes, make sure that your system chassis provides excellent conductivity between the power supply, the case, the mounting fasteners, and the add-on card.

#### Unpacking

The add-on card is shipped in antistatic packaging to avoid static damage. When unpacking your component or system, make sure you are static protected.



**Note:** To avoid damaging your components and to ensure proper installation, always connect the power cord last, and always unplug it before adding, removing, or changing any hardware components.

## 3.2 Before Installation

To install the add-on card properly, be sure to follow the instructions:

1. Power down the system.
2. Remove the power cord from the wall socket.
3. Use industry-standard antistatic equipment (such as gloves or a wrist strap) and follow the instructions listed on [page 20](#) to avoid damage caused by ESD.
4. Familiarize yourself with the server, motherboard, and/or chassis documentation.
5. Confirm that your operating system includes the latest updates and hot fixes.

### 3.3 Installing the Add-on Card (with a 0.5U Bracket)

Follow the steps to install an add-on card into your system. If the system is fixed onto a rack, the removal of the server top cover is not required. If the system is not anchored to a fixed structure, it is recommended to remove the system's top cover for ease of installation.

#### Uninstalling an AIOM Module

1. Unscrew the blue knob from the system.
2. Pull on the tab and knob evenly on both sides of the card to disengage the AIOM module from the motherboard connector.
3. Gently slide the AIOM module out.

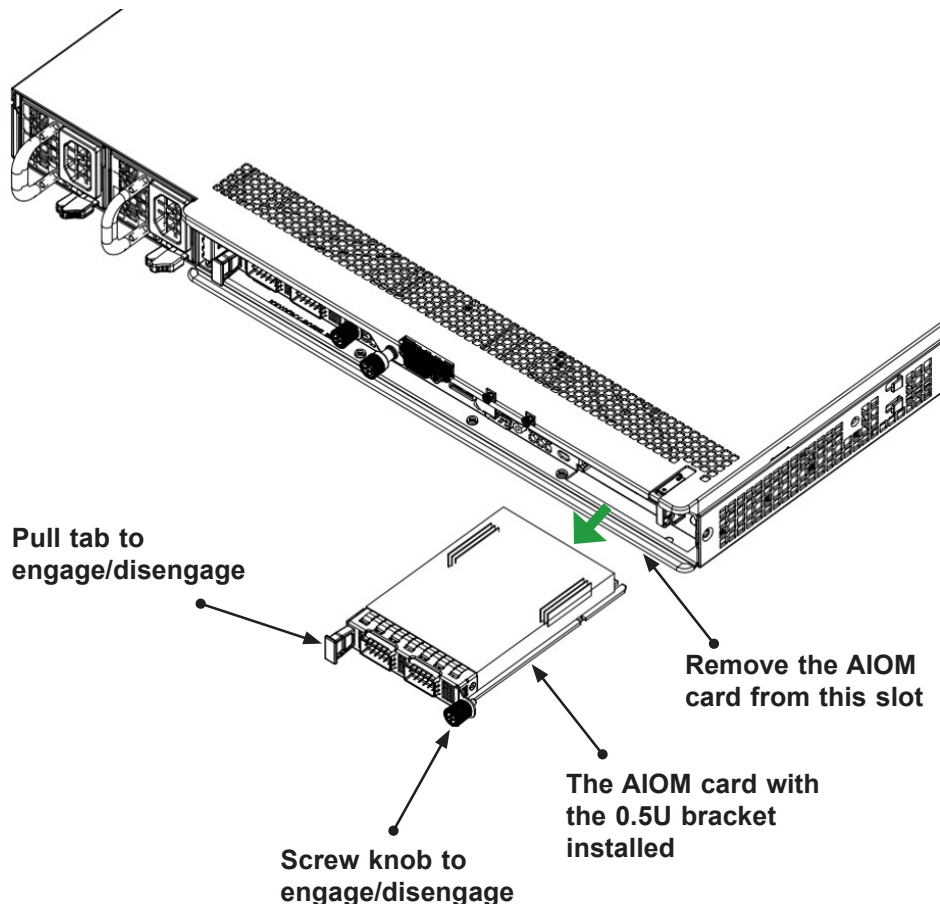

Figure 3-1: Uninstalling the AIOM Module

## Installing an AIOM Module

1. Position the AIOM module in front of the empty slot and gently push it onto the metal bracket. The AIOM module should slide into the chassis until the card is securely seated in the connector.
2. Press the blue knob and secure it onto the chassis by turning the knob clockwise.

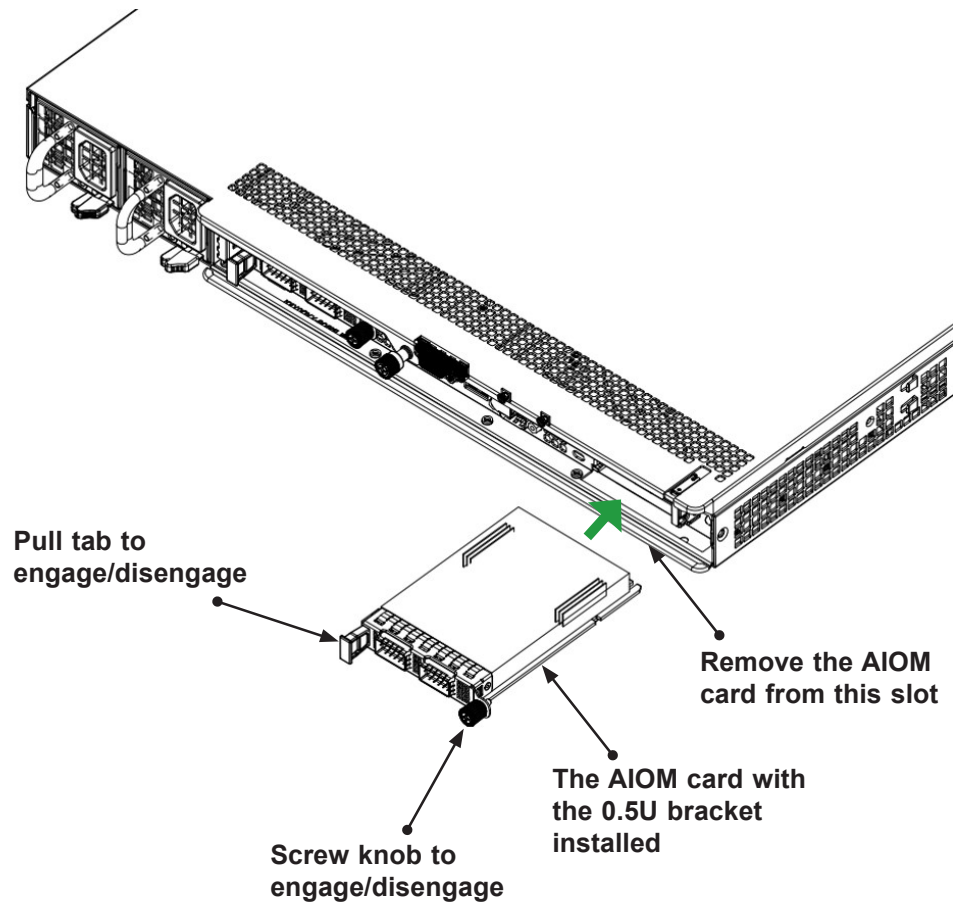
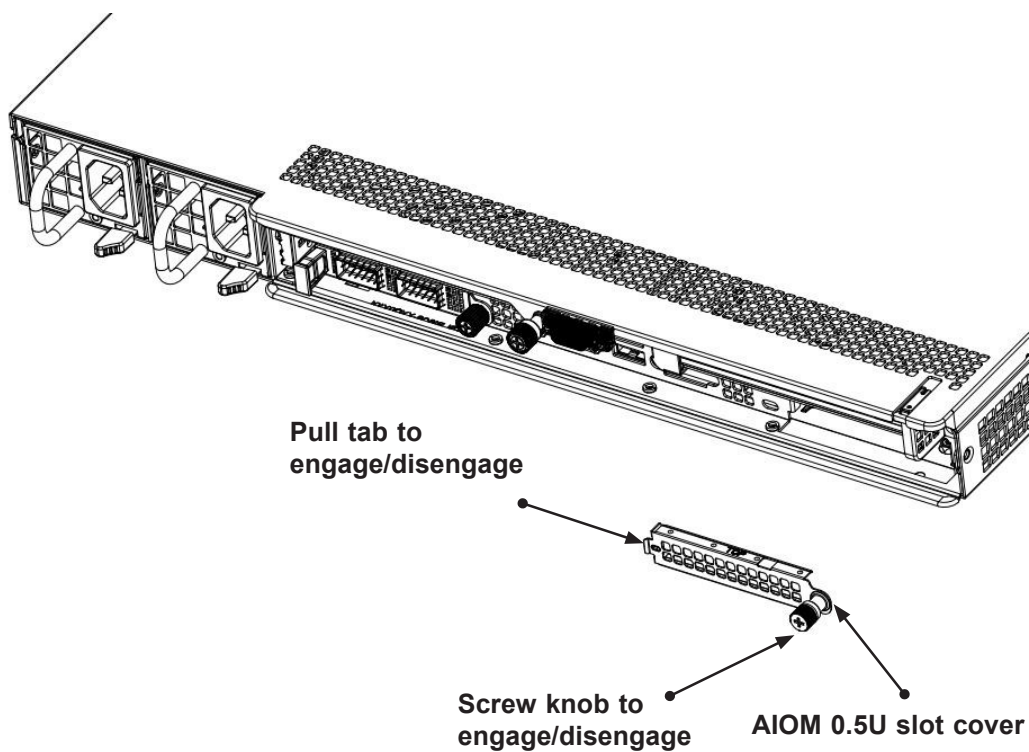

Figure 3-2: Installing the AIOM Module

## Installing an AIOM Module (with an AIOM Slot Cover)

1. Remove the AIOM slot cover by unscrewing the screw and knob that attaches the bracket to the chassis.
2. Pull the bracket away and set it aside.
3. Position the AIOM module in front of the empty slot and gently push it onto the metal bracket. The AIOM module should slide into the chassis until the card is securely seated in the connector.
4. Press the blue knob and secure it onto the chassis by turning the knob clockwise.



**Figure 3-3: Installing the AIOM Module**



**Note 1:** This AIOM module does not support the hot plug. Turn off the AC power and remove the power cord from the wall socket before installing or removing an AIOM module.

**Note 2:** Graphics shown above are for illustration purposes only. Actual products may vary due to product enhancement.

## 3.4 Installing Drivers (for Mellanox ConnectX-6 Dx)

To install drivers for the AOC-A100G-m2CM/-m2CG add-on card for either Linux or Windows, follow the instructions:

### Before Installing the Drivers for the Linux Operating System

Infiniband-diags is a set of utilities designed to help configure, debug, and maintain infiniband fabrics. Installing them from the Linux library is necessary prior to driver installation. To do so, first download the following libraries:

```
yum -y install libibverbs* infiniband-diags perftest qperf librd-  
macm-utils
```

```
yum -y install groupinstall "InfiniBand Support"
```

### Installing 100 GbE Drivers for the Linux Operating System

Use the following procedures to install the 100 GbE driver on the Linux (RedHat/CentOS) operating system:

1. We recommend downloading the latest Mellanox Driver directly from the Mellanox website: [https://mellanox.com/products/infiniband-drivers/linux/mlnx\\_ofed](https://mellanox.com/products/infiniband-drivers/linux/mlnx_ofed).
2. Download and extract /untar the MLNX\_OFED\*\*\*.tgz package.
3. Change to the appropriate directory where your newly extracted package is located.
4. Install the driver by entering the following commands:

```
tar xzvf MLNX_OFED_LINUX-<ver>.tgz  
  
cd MLNX_OFED_LINUX-<ver>  
  
./mlnxofedinstall --without-fw-update
```

This installs the Linux driver into your system. You might be prompted to install kernel dependencies for Linux. In which case, you would need to follow on-screen instructions.

## Installing 100 GbE Drivers for the Windows Operating System

Follow the steps to install the drivers on the Windows operating system:

1. We recommend downloading the latest Mellanox Driver directly from the Mellanox website: <https://mellanox.com/products/adapter-software/ethernet/windows/winof-2>.
2. Once the driver is downloaded, run the .exe file to install the driver.

(Disclaimer Continued)

The products sold by Supermicro are not intended for and will not be used in life support systems, medical equipment, nuclear facilities or systems, aircraft, aircraft devices, aircraft/emergency communication devices or other critical systems whose failure to perform be reasonably expected to result in significant injury or loss of life or catastrophic property damage. Accordingly, Supermicro disclaims any and all liability, and should buyer use or sell such products for use in such ultra-hazardous applications, it does so entirely at its own risk. Furthermore, buyer agrees to fully indemnify, defend and hold Supermicro harmless for and against any and all claims, demands, actions, litigation, and proceedings of any kind arising out of or related to such ultra-hazardous use or sale.