

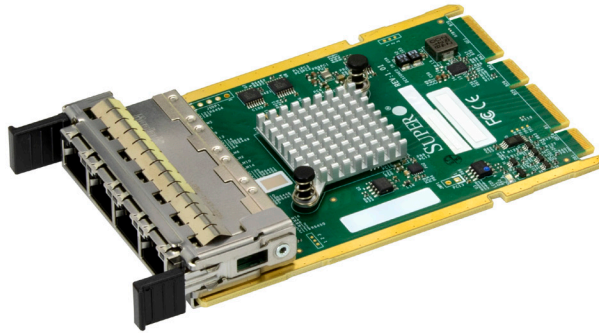

AOC-AG-i4G

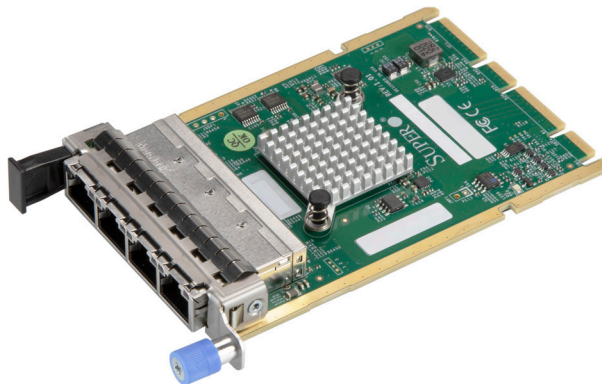

AOC-AG-i4M



USER'S MANUAL

Revision 1.0a

The information in this user's manual has been carefully reviewed and is believed to be accurate. The manufacturer assumes no responsibility for any inaccuracies that may be contained in this document, and makes no commitment to update or to keep current the information in this manual, or to notify any person or organization of the updates. **Please Note: For the most up-to-date version of this manual, please see our website at www.supermicro.com.**

Super Micro Computer, Inc. ("Supermicro") reserves the right to make changes to the product described in this manual at any time and without notice. This product, including software and documentation, is the property of Supermicro and/or its licensors, and is supplied only under a license. Any use or reproduction of this product is not allowed, except as expressly permitted by the terms of said license.

IN NO EVENT WILL Super Micro Computer, Inc. BE LIABLE FOR DIRECT, INDIRECT, SPECIAL, INCIDENTAL, SPECULATIVE OR CONSEQUENTIAL DAMAGES ARISING FROM THE USE OR INABILITY TO USE THIS PRODUCT OR DOCUMENTATION, EVEN IF ADVISED OF THE POSSIBILITY OF SUCH DAMAGES. IN PARTICULAR, SUPER MICRO COMPUTER, INC. SHALL NOT HAVE LIABILITY FOR ANY HARDWARE, SOFTWARE, OR DATA STORED OR USED WITH THE PRODUCT, INCLUDING THE COSTS OF REPAIRING, REPLACING, INTEGRATING, INSTALLING OR RECOVERING SUCH HARDWARE, SOFTWARE, OR DATA.

Any disputes arising between manufacturer and customer shall be governed by the laws of Santa Clara County in the State of California, USA. The State of California, County of Santa Clara shall be the exclusive venue for the resolution of any such disputes. Supermicro's total liability for all claims will not exceed the price paid for the hardware product.

FCC Statement: This equipment has been tested and found to comply with the limits for a Class A digital device pursuant to Part 15 of the FCC Rules. These limits are designed to provide reasonable protection against harmful interference when the equipment is operated in industrial environment. This equipment generates, uses, and can radiate radio frequency energy and, if not installed and used in accordance with the manufacturer's instruction manual, may cause harmful interference with radio communications. Operation of this equipment in a residential area is likely to cause harmful interference, in which case you will be required to correct the interference at your own expense.

California Best Management Practices Regulations for Perchlorate Materials: This Perchlorate warning applies only to products containing CR (Manganese Dioxide) Lithium coin cells. "Perchlorate Material-special handling may apply. See www.dtsc.ca.gov/hazardouswaste/perchlorate".



WARNING: This product can expose you to chemicals including lead, known to the State of California to cause cancer and birth defects or other reproductive harm. For more information, go to www.P65Warnings.ca.gov.

The products sold by Supermicro are not intended for and will not be used in life support systems, medical equipment, nuclear facilities or systems, aircraft, aircraft devices, aircraft/emergency communication devices or other critical systems whose failure to perform be reasonably expected to result in significant injury or loss of life or catastrophic property damage. Accordingly, Supermicro disclaims any and all liability, and should buyer use or sell such products for use in such ultra-hazardous applications, it does so entirely at its own risk. Furthermore, buyer agrees to fully indemnify, defend and hold Supermicro harmless for and against any and all claims, demands, actions, litigation, and proceedings of any kind arising out of or related to such ultra-hazardous use or sale.

Manual Revision 1.0a

Release Date: March 25, 2025

Unless you request and receive written permission from Super Micro Computer, Inc., you may not copy any part of this document. Information in this document is subject to change without notice. Other products and companies referred to herein are trademarks or registered trademarks of their respective companies or mark holders.

Copyright © 2025 by Super Micro Computer, Inc.
All rights reserved.

Printed in the United States of America

Preface

About This Manual

This user's guide is written for system integrators, IT technicians, and knowledgeable end users. It provides information for the installation and use of the AOC-AG-i4G/AOC-AG-i4M add-on module.

About This Add-On Card

The Supermicro® Advanced I/O Module (AIOM) is the latest form factor designed to provide a wide range of networking options as well as other I/O technologies. The AOC-AG-i4G/AOC-AG-i4M is the most flexible and scalable GbE solution with four RJ45 port support currently available on the market. Based on the Intel® network controller i350 with performance-enhancing features and power management technologies built in, AOC-AG-i4G/AOC-AG-i4M provides quality networking choice for data centers while reducing CPU utilization and power consumption. With the added NC-SI feature, this adapter also functions as a secure networking port for server remote management.

An Important Note to the User

All graphic images and layout drawings shown in this user's guide are based upon the latest PCB revision available at the time of publishing this user's guide. The add-on card you have received may or may not look exactly the same as the graphics shown in this user's guide.

Returning Merchandise for Service

A receipt or copy of your invoice marked with the date of purchase is required before any warranty service will be rendered. You can obtain service by calling your vendor for a Returned Merchandise Authorization (RMA) number. When returning to the manufacturer, the RMA number should be prominently displayed on the outside of the shipping carton and mailed prepaid or hand-carried. Shipping and handling charges will be applied for all orders that must be mailed when service is complete. For faster service, RMA authorizations may be requested online (<http://www.supermicro.com/support/rma/>).

This warranty only covers normal consumer use and does not cover damages incurred in shipping or from failure due to the alteration, misuse, abuse, or improper maintenance of products.

During the warranty period, contact your distributor first for any product problems.

Conventions Used in the Manual

Special attention should be given to the following symbols for proper installation and to prevent damage done to the components or injury.



Warning! Indicates important information given to prevent equipment/property damage or personal injury.



Warning! Indicates high voltage may be encountered while performing a procedure.



Important: Important information given to ensure proper system installation or to relay safety precautions.



Note: Additional information given to differentiate various models or to provide information for proper system setup.

Important Links

For your system to work properly, follow the links below to download all necessary drivers/utilities and the user's manual for your server.

- Supermicro product manuals: <http://www.supermicro.com/support/manuals/>
- Product drivers and utilities: <https://www.supermicro.com/wdl/driver>
- Product safety info: http://www.supermicro.com/about/policies/safety_information.cfm
- A secure data deletion tool designed to fully erase all data from storage devices can be found at our website: https://www.supermicro.com/about/policies/disclaimer.cfm?url=/wdl/utility/Lot9_Secure_Data_Deletion_Utility/
- If you have any questions, contact our support team at: support@supermicro.com
- Frequently Asked Questions: <https://www.supermicro.com/FAQ/index.php>
- If you have any feedback on Supermicro product manuals, contact our writing team at: Techwriterteam@supermicro.com

This manual may be periodically updated without notice. Check the Supermicro website for possible updates to the manual revision level.

Naming Convention

AOC-ATG-i2T2SM



Character	Representation	Options
1st	Product Family	AOC: Add On Card
2nd	Form Factor	S: Standard, P: Proprietary, C: MicroLP, M: Super IO Module (SIOM), MH: SIOM Hybrid A: Advanced IO Module (AIOM), AH: AIOM Hybrid
3rd	Product Type/Speed	G: GbE (1Gb/s), TG: 10GbE (10Gb/s), 25G: 25GbE (25Gb/s), 40G: 40GbE (40Gb/s), 50G: 50GbE (50Gb/s), 100G: 100GbE (100Gb/s), IBE: EDR IB (100Gb/s), HFI: Host Fabric Interface
4th	Chipset Model (Optional)	N: Niantec (82599), P: Powerville (i350), S: Sageville (X550), F: Fortville (XL710/X710), L: Lewisburg (PCH)
5th	Chipset Manufacturer	i: Intel, m: Mellanox, b: Broadcom
6th	Number of Ports	1: 1 port, 2: 2 ports, 4: 4 ports, 8: 8 ports
7th	Connector Type (Optional)	S: SFP/SFP+/SFP28, T: 10GBase-T, Q: QSFP+, C: QSFP28
8th	2 nd Controller/Connector Type (Optional)	G: 1x GbE RJ45, 2G: GbE 2x RJ45, S: 1x 10G SFP+, T: 10GBase-T, 2T: 2x 10GBase-T, 2S: 2x SFP+
9th	Bracket	For SIOM – Non-M: swappable bracket for Storage systems, M: Internal bracket for Twin systems. For AIOM – Non-M: 1U height bracket for Edge systems, M: 0.5U height bracket for all other systems.

Contacting Supermicro

Headquarters

Address: Super Micro Computer, Inc.
980 Rock Ave.
San Jose, CA 95131 U.S.A.

Tel: +1 (408) 503-8000

Fax: +1 (408) 503-8008

Email: marketing@supermicro.com (General Information)
Sales-USA@supermicro.com (Sales Inquiries)
Government_Sales-USA@supermicro.com (Gov. Sales Inquiries)
support@supermicro.com (Technical Support)
RMA@supermicro.com (RMA Support)
Webmaster@supermicro.com (Webmaster)

Website: www.supermicro.com

Europe

Address: Super Micro Computer B.V.
Het Sterrenbeeld 28, 5215 ML
's-Hertogenbosch, The Netherlands

Tel: +31 (0) 73-6400390

Fax: +31 (0) 73-6416525

Email: Sales_Europe@supermicro.com (Sales Inquiries)
Support_Europe@supermicro.com (Technical Support)
RMA_Europe@supermicro.com (RMA Support)

Website: www.supermicro.nl

Asia-Pacific

Address: Super Micro Computer, Inc.
3F, No. 150, Jian 1st Rd.
Zhonghe Dist., New Taipei City 235
Taiwan (R.O.C)

Tel: +886-(2) 8226-3990

Fax: +886-(2) 8226-3992

Email: Sales-Asia@supermicro.com.tw (Sales Inquiries)
Support@supermicro.com.tw (Technical Support)
RMA@supermicro.com.tw (RMA Support)

Website: www.supermicro.com.tw

Table of Contents

Chapter 1 Introduction

1.1 Overview.....	8
1.2 Key Features	8
1.3 Specifications	9
1.4 Available SKUs.....	11

Chapter 2 Hardware Components

2.1 Add-On Card Image and Layout.....	12
2.2 Major Components	15
2.3 LAN Indicators and Connectors	16
2.4 PCIe 2.1 x4 AIOM Form Factor Connector	18

Chapter 3 Installation

3.1 Overview.....	19
3.2 Static-Sensitive Devices.....	19
3.3 Before Installation.....	20
3.4 Installing the Add-on Card AOC-AG-i4G (with 0.5U bracket for Grand Twin Front IO).....	21
3.5 Installing the Add-on Card AOC-AG-i4M (with 0.5U bracket).....	24
3.6 Installing the Drivers in Windows (for Intel i350-AM4).....	27
3.7 Installing the Drivers on Linux (for Intel i350-AM4)	28
3.8 Installing the Drivers on FreeBSD (for Intel i350-AM4)	30

Chapter 1

Introduction

1.1 Overview

Congratulations on purchasing your add-on card from an acknowledged leader in the industry. Supermicro products are designed with the utmost attention to detail to provide you with the highest standards of quality and performance. For product support and updates, refer to our website at <https://www.supermicro.com/en/products/networking/adapters>.

1.2 Key Features

The key features of this add-on card include the following:

- Advanced I/O Module (AIOM) form factor
- Four 1 Gbps ports with RJ45 connectors
- Intel i350 GbE controller
- Energy Efficient Ethernet (EEE)
- Reliable and proven Gigabit Ethernet technology
- Asset Management features with thermal sensor
- NC-SI for Remote Management
- RoHS compliant 6/6 

1.3 Specifications

General

- Advanced I/O Module (AIOM) form factor
- Intel i350 GbE controller
- Four 1 Gbps ports: 4x RJ45 connectors

Networking Features

- IEEE 802.3 auto-negotiation for speed, duplex, and flow control
- IEEE 802.3x and 802.3z compliant flow control support
- Automatic cross-over detection function (MDI/MDI-X)
- 1 Gb/s Ethernet IEEE 802.3, 802.3u, 802.3ab PHY specifications compliant

Virtualization Features

- PC-SIG SR-IOV support
- VM to VM packet forwarding (packet loopback)
- Flexible port partitioning
- IEEE 802.1q VLAN support
- IEEE 802.1q advanced packet filtering
- Jumbo frames support

Power Management and Efficiency

- Energy Efficient Ethernet (EEE)
- DMA Coalescing reduces platform power consumption
- PCI Express Active State Power Management (ASPM)

- LAN disable function
- Low power link up — Link speed control

Performance Features

- TCP/UDP, IPv4, and IPv6 checksum offloads to improve CPU usage
- Low latency interrupts
- Tx TCP segmentation offload (IPv4, IPv6) increases throughput and lowers processor usage
- Receive Side Scaling (RSS) for Windows environment, Scalable I/O for Linux environments
- Intelligent interrupt generation

Management Features

- Preboot eXecution Environment (PXE) support
- iSCSI remote boot support
- Asset Management support on Supermicro platforms
- NC-SI for remote management

OS Support

- Windows® Server
- RedHat Linux
- SUSE Linux
- FreeBSD
- UEFI
- VMWare

Power Consumption

- Maximum power consumption: 4.4 W

Operating Conditions

- Storage temperature: -40°C to 70°C (-40°F to 158°F)
- Storage humidity: 90% non-condensing relative humidity at 35°C

Physical Dimensions

- Card PCB dimensions: 2.99" x 4.53" (76 mm x 115 mm) (W x D)



Note: This product is only sold as part of an integrated solution with Supermicro server systems.

1.4 Available SKUs

SKUs	Bracket Included	Description
AOC-AG-i4G	BKT-0225L	4-port Gigabit Ethernet Adapter with a 0.5U height bracket for Grand Twin Front IO systems
AOC-AG-i4M	BKT-0178L	4-port Gigabit Ethernet Adapter with a 0.5U height bracket

Chapter 2

Hardware Components

2.1 Add-On Card Image and Layout

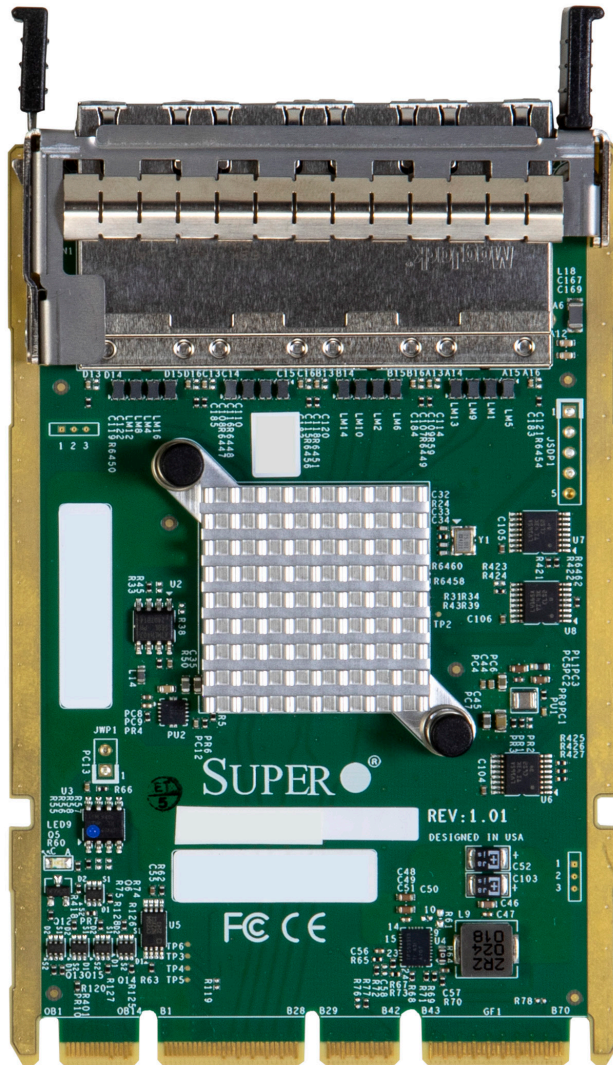

Figure 2-1: AOC-AG-i4G Top View

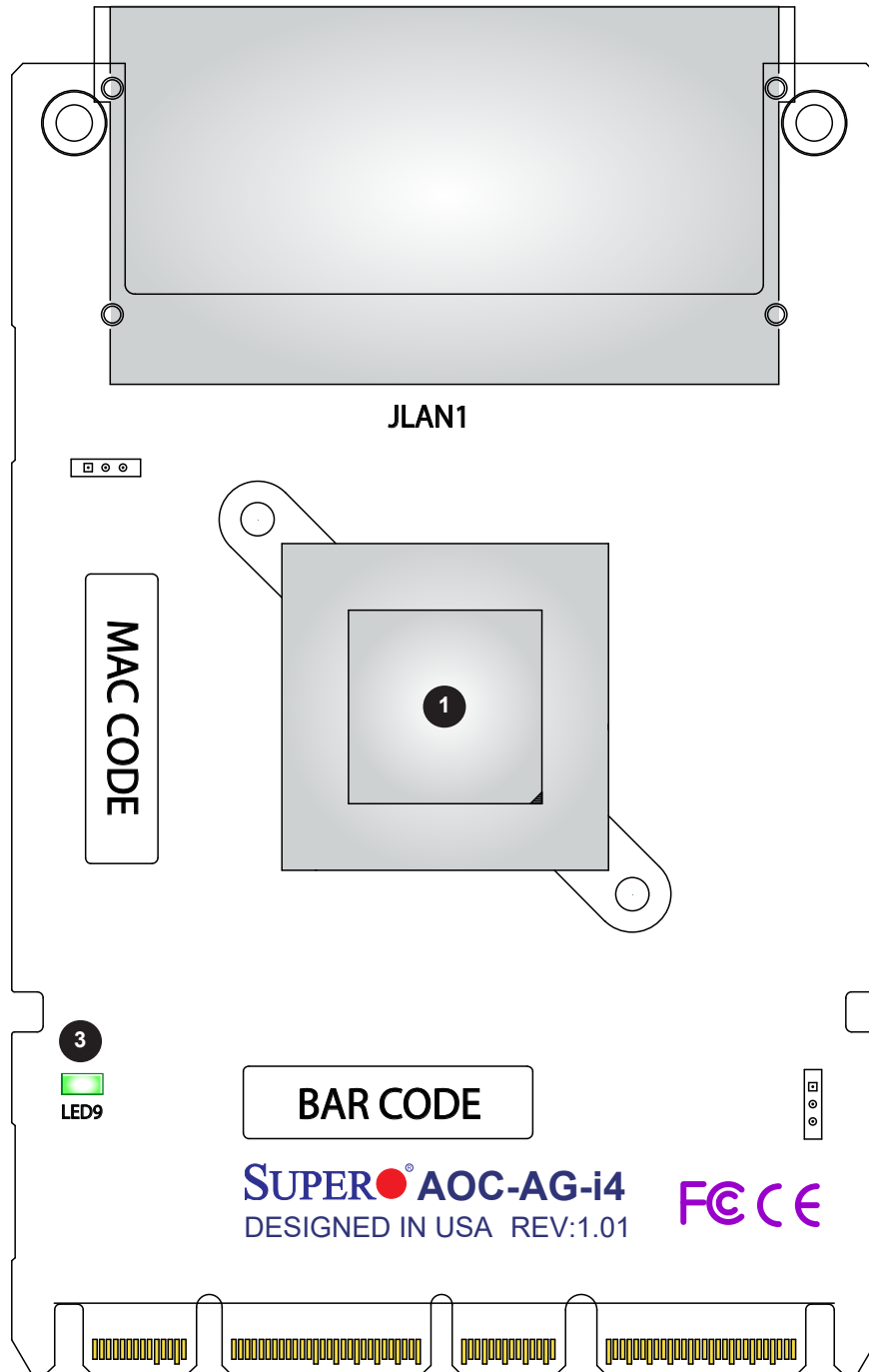

Figure 2-3: AOC-AG-i4 Layout

2.2 Major Components

The following major components are installed on the AOC-AG-i4G/-i4M:

AOC-AG-i4G/-i4M Major Components		
No	Component Name	Definition
1	Intel i350 GbE	Ethernet Controller
2	JLAN1	LAN (RJ45) Port
3	LED9	On: Power Rails Ready
		Off: Power Rails Not Ready

2.3 LAN Indicators and Connectors

LAN Ports

The AOC-AG-i4G/i4M has four network LAN (RJ45) ports. These LAN ports support connection speeds up to 1 Gbps. Plug the Direct Attached Copper (DAC) cable into the RJ45 port for network connections.

 **Note 1:** To make sure that LAN port functions properly, be sure to use one of the following cables specified by the manufacturer:

- Direct-attached twin-axial copper cable
- Short range or long range fiber optic cable used in conjunction with optional optical transceiver

Note 2: For detailed information on the cable and transceiver recommended by the manufacturer, refer to "Optional Accessories" on [section 1-4](#) or the Supermicro product information posted online.

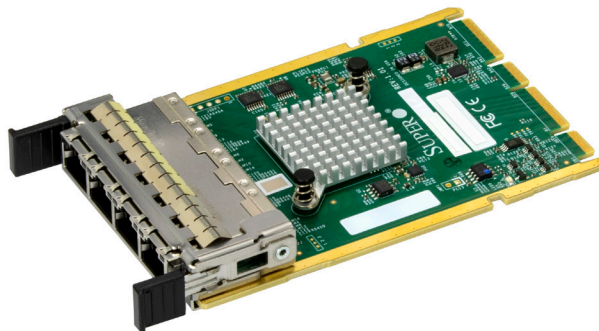

Figure 2-4: AOC-AG-i4G

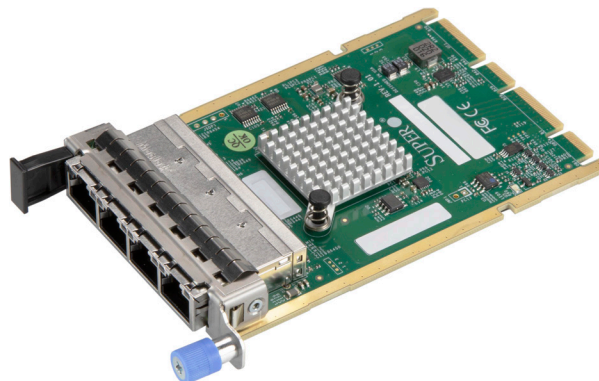

Figure 2-5: AOC-AG-i4M

LAN LED

Each RJ45 connector has two LEDs. The LEDs on the left of a port indicates link speeds, while the LEDs on the right indicates the status of activity of the connector.

Port LED State		
LED Color	Color	Definition
Link (Left)	Green	1 Gbps Link Speed
	Amber	100 Mbps Link Speed
Amber (Right)	Green Flashing	Activity

2.4 PCIe 2.1 x4 AIOM Form Factor Connector

Explanation of Jumpers

Insert the PCIe 2.1 x4 AIOM form factor connector into a PCIe 2.1 x4 AIOM form factor slot on a motherboard to use this AIOM form factor card.

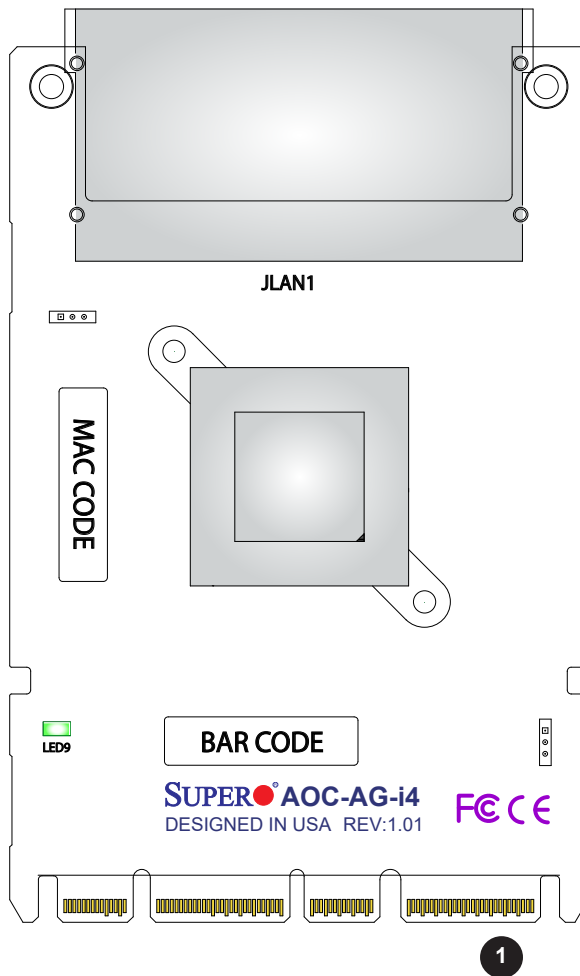

1. PCIe 2.1 x4 AIOM form factor connector

Chapter 3

Installation

3.1 Overview

As a part of an integrated solution, your system came with the adapter pre-installed. We do not recommend removing and reinstalling any part of your system components. If you need to remove or re-install a system component, including this add-on card, follow the instructions in this chapter to ensure proper system setup.

3.2 Static-Sensitive Devices

Electrostatic Discharge (ESD) can damage electronic components. To avoid damaging your add-on card, it is important to handle it very carefully. The following measures are generally sufficient to protect your equipment from ESD.

Precautions

- Use a grounded wrist strap designed to prevent static discharge.
- Touch a grounded metal object before removing the add-on card from the antistatic bag.
- Handle the add-on card by its edges only; do not touch its components or peripheral chips.
- Put the add-on card back into the antistatic bags when not in use.
- Be sure to remove the power cord first before adding, removing, or changing any hardware components to avoid damaging the system or components.
- For grounding purposes, make sure that your system chassis provides excellent conductivity between the power supply, the cage, the mounting fasteners, and the add-on card.

Unpacking

The add-on card is shipped in antistatic packaging to avoid static damage. When unpacking your component or system, make sure you are static protected.



Note: To avoid damaging your components and to ensure proper installation, always connect the power cord last, and always unplug it before adding, removing, or changing any hardware components.

3.3 Before Installation

To install the add-on card properly, be sure to follow the instructions.

1. Power down the system.
2. Remove the power cord from the wall socket.
3. Use industry-standard antistatic equipment (such as gloves or wrist strap) and follow the instructions listed on [page 19](#) to avoid damage caused by ESD.
4. Familiarize yourself with the server, motherboard, and/or chassis documentation.
5. Confirm that your operating system includes the latest updates and hot fixes.

3.4 Installing the Add-on Card AOC-AG-i4G (with 0.5U Bracket for Grand Twin Front IO)

Follow the steps to install an add-on card into your system. If the system is fixed onto a rack, the removal of the server top cover is not required. If the system is not anchored to a fixed structure, it is recommended to remove the system top cover for ease of installation.

Uninstalling an AIOM (with AIOM in Slot)

1. Slide the black latch to the left to the "unlock" position.
2. Disengage the AIOM from the chassis structure by pushing the blue latch once to extend it outward.



Black Latch

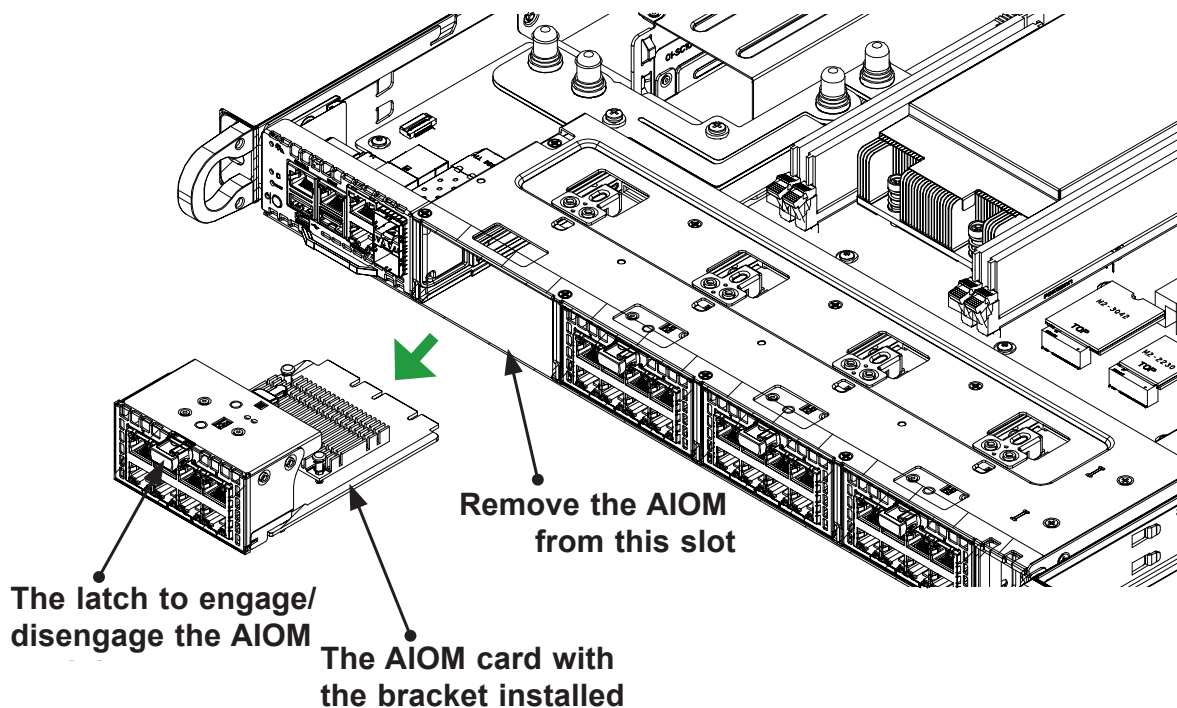

Figure 3-1: Disengaging the AIOM From Chassis

Installing an AIOM (Reinstalling Into Empty Slot)

1. Position the AIOM in front of the empty slot and gently push onto the metal bracket. The module should slide into the chassis until the module is securely seated in the connector.
2. Press the blue latch to properly secure it onto the chassis and move the black latch to the right to the "lock" position.

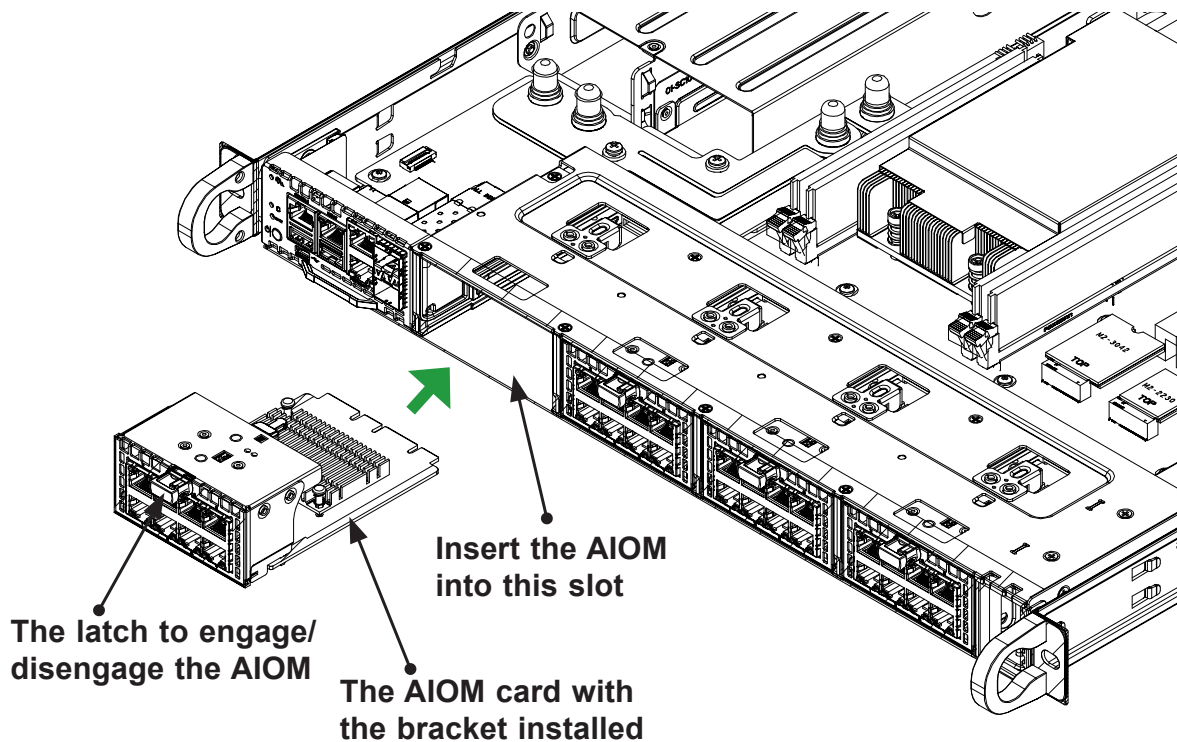



Figure 3-2: Pushing AIOM onto Metal Bracket

 **Note:** A computer system should not be operating with an empty AIOM slot. All slots should be populated with modules, AIOM slot covers, or combinations of both.

Installing an AIOM (With an AIOM Slot Cover)

1. Remove the AIOM slot cover by pulling it with two handles.
2. Position the AIOM in front of the empty slot and gently push onto the metal bracket (do not use the blue latch). The module should slide into the chassis until the card is fully seated inside the connector.
3. Press the blue latch to secure it onto the chassis structure.

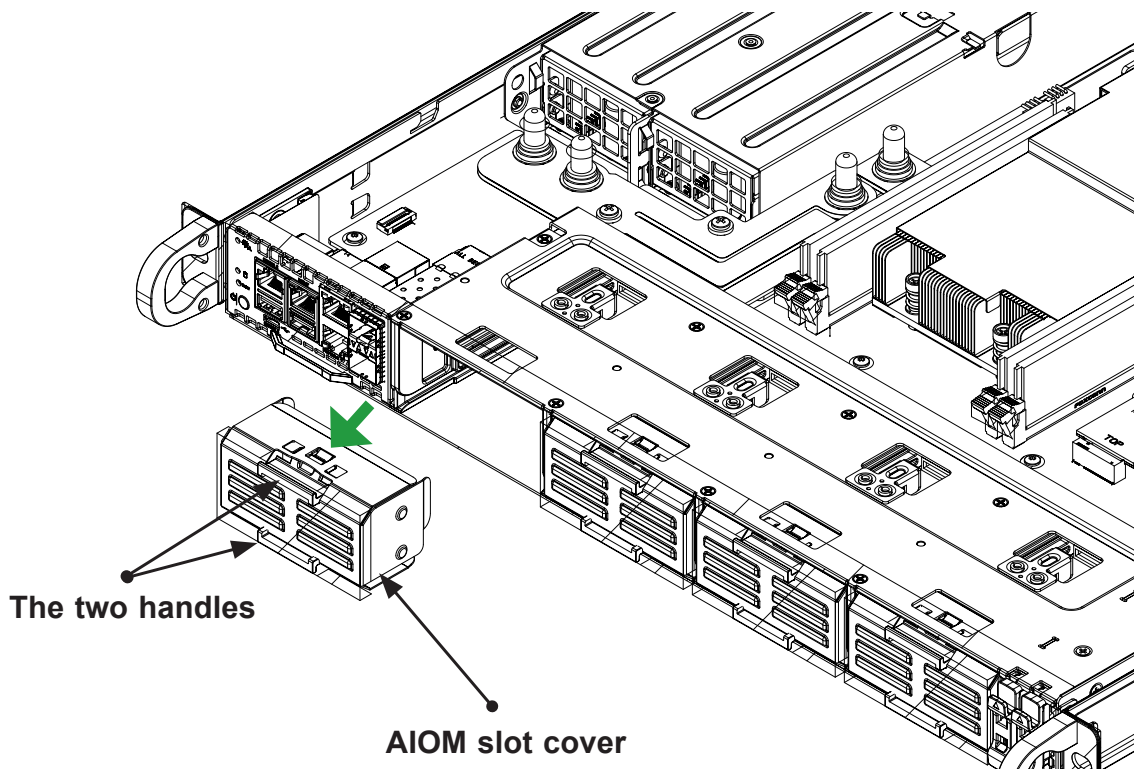



Figure 3-3: Removing the AIOM Slot Cover

 **Note:** This AIOM does not support hot plug. Turn off the AC power and remove the power cord from the wall socket before installing or removing an AIOM.

3.5 Installing the Add-on Card AOC-AG-i4M (With 0.5U Bracket)

Follow the steps to install an add-on card into your system. If the system is fixed onto a rack, the removal of the server top cover is not required. If the system is not anchored to a fixed structure, it is recommended to remove the system top cover for ease of installation.

Uninstalling an AIOM (with AIOM in the Slot)

1. Unscrew the blue knob from the system.
2. Pull on the tab and a knob evenly on both sides of the card to disengage the AIOM from the motherboard connector.
3. Gently slide the AIOM out.

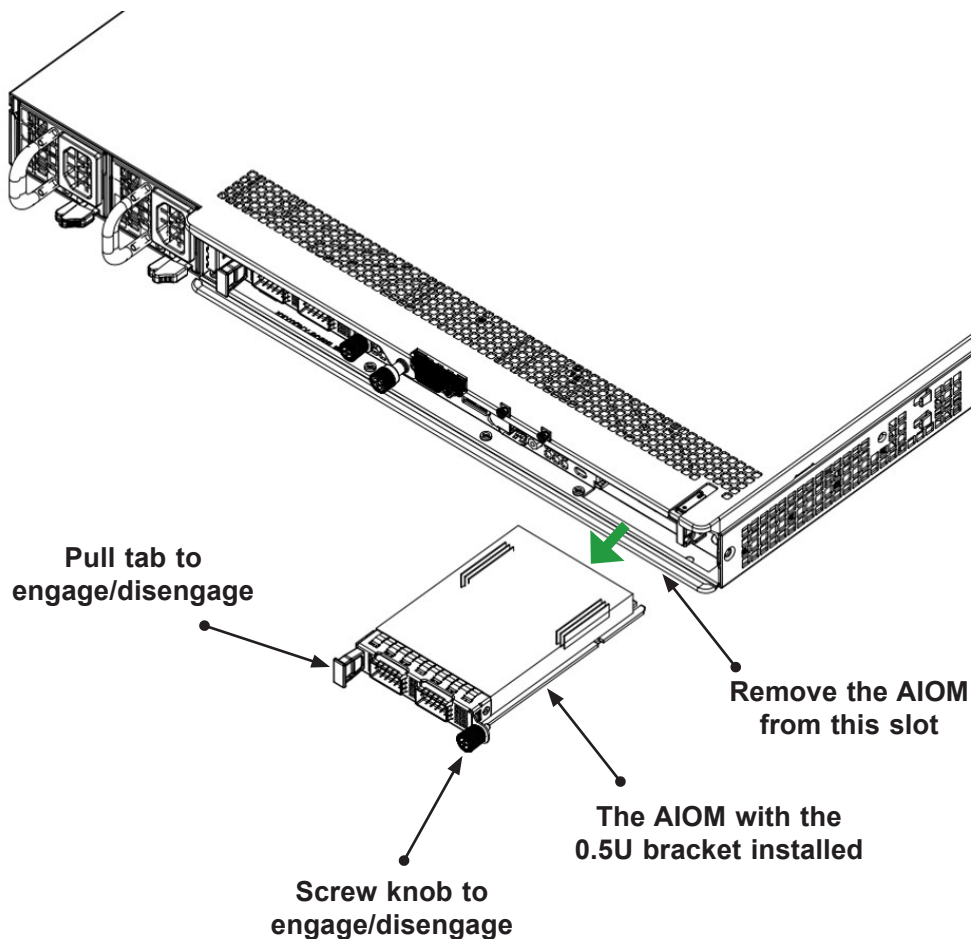

Figure 3-4: Removing the AIOM From the Slot

Installing an AIOM

1. Position the AIOM in front of the empty slot and gently push onto the metal bracket. The module should slide into the chassis until the card is securely seated in the connector.
2. Press the blue knob and secure it onto the chassis by turning the knob clockwise.

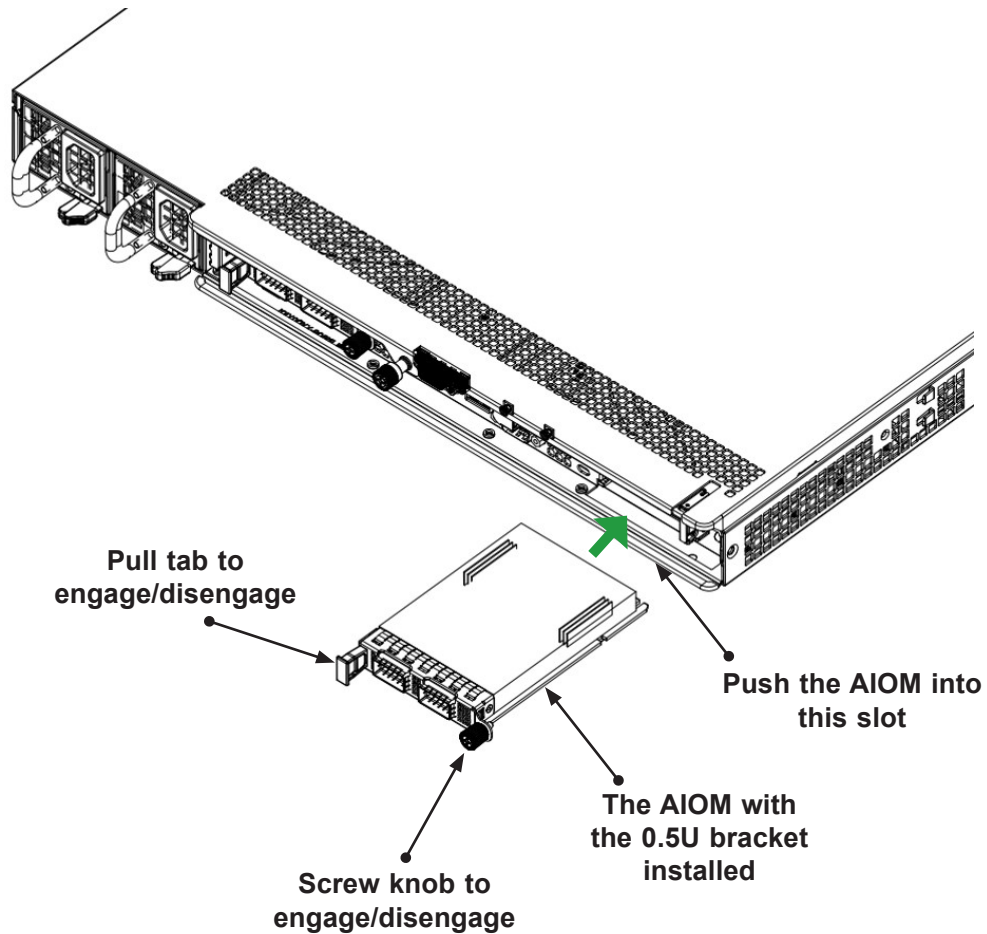

Figure 3-5: Pushing the AIOM Into the Slot

Installing an AIOM (With an AIOM Slot Cover)

1. Remove the AIOM slot cover by unscrewing the knob and screw that attaches the bracket to the chassis. Pull the bracket away and set it aside.
2. Position the AIOM in front of the empty slot and gently push onto the metal bracket. The module should slide into the chassis until the module is securely seated in the connector.
3. Press the blue knob and secure it onto the chassis by turning the knob clockwise.

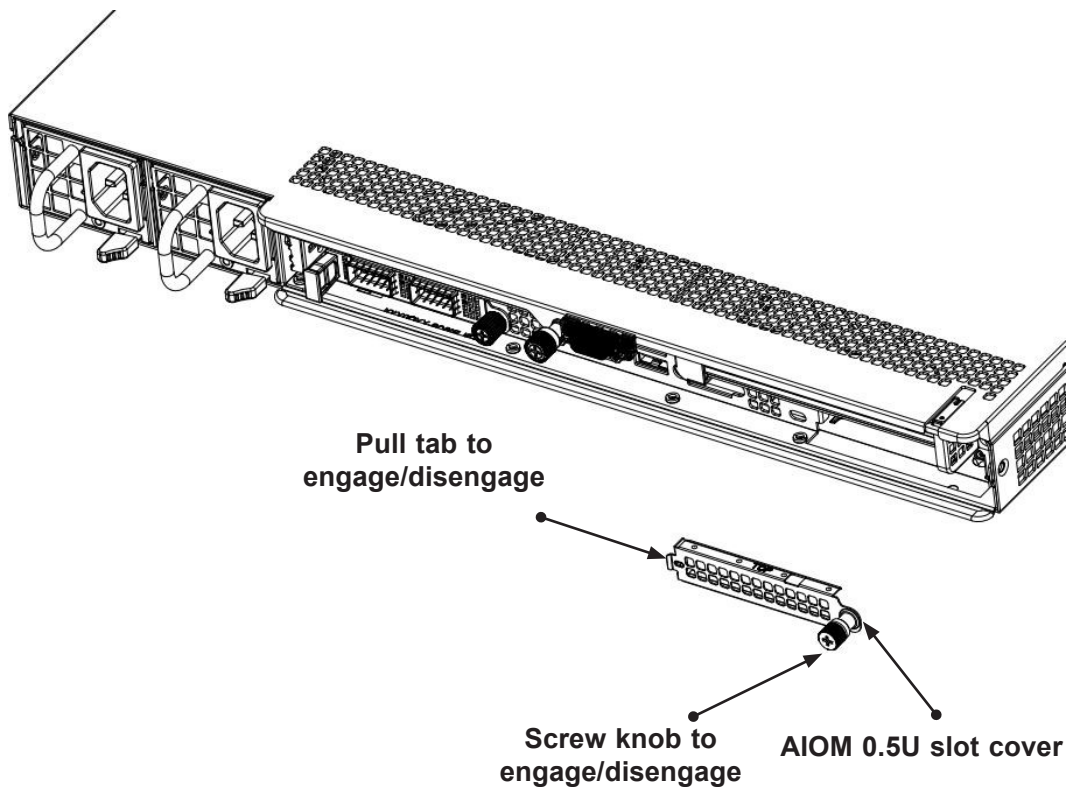



Figure 3-6: Removing the Slot Cover

 **Note 1:** This AIOM does not support hot plug. Turn off the AC power and remove the power cord from the wall socket before installing or removing an AIOM.

Note 2: Pictures shown above are for illustration purposes only. The pictures of the actual product may vary due to product enhancement.

3.6 Installing the Drivers in Windows (for Intel i350-AM4)

Follow the steps to install the drivers for Windows. Download the latest drivers from the Supermicro project board at <https://www.supermicro.com/wdl/driver>.

1. Run CDR-NIC.
2. When the SUPERMICRO window appears, click on the computer icon next to the product model.



Figure 3-7: Add-on Card Drivers and Tools



Note: If the *FOUND NEW HARDWARE WIZARD* screen displays on your system, click CANCEL.

3. Click on INSTALL DRIVERS AND SOFTWARE.
4. Follow the prompts to complete the installation.

3.7 Installing the Drivers on Linux (for Intel i350-AM4)

Download the drivers from Intel Download Center or the Supermicro site at https://www.supermicro.com/wftp/Networking_Drivers.

Build a Binary RPM Package

1. Run 'rpmbuild -tb <filename.tar.gz>'.
2. Replace <filename.tar.gz> with the specific filename of the driver.



Note: For the build to work properly, the current running kernel MUST match the version and configuration of the installed kernel sources. If you have just recompiled the kernel, reboot the system at this time.

Follow the instructions to build the driver manually.

1. Move the base driver tar file to the directory of your choice. For example:

```
/home/username/igb
```

or

```
/usr/local/src/igb
```

2. Untar/unzip archive, where <x.x.x> is the version number for the driver tar file:

```
tar xzf igb-x.x.x.tar.gz
```

3. Change to the driver src directory, where <x.x.x> is the version number for the driver tar:

```
cd igb-x.x.x/src/
```

4. Compile the driver module:

```
make install
```

The binary will be installed as:

```
/lib/modules/[KERNEL_VERSION]/kernel/drivers/net/igb/igb.[k]o
```

The install locations listed above are the default locations. They may not be correct for certain Linux distributions. For more information, see the `ldistrib.txt` file included in the driver tar. This will install the Linux driver to your system. For more driver installation information, refer to the [Intel support website](#).



Note: IGB_NO_LRO is a compile time flag. You can enable it at compile time to remove support for LRO from the driver. The flag is used by adding CFLAGS_EXTRA="-DIGB_NO_LRO" to the make file when it's being compiled.

```
make CFLAGS_EXTRA="-DIGB_NO_LRO" install
```

5. Load the module:

For kernel 2.6.x, use the modprobe command:

```
modprobe igb <parameter>=<value>
```

For 2.6 kernels, the insmod command can be used if the full path to the driver module is specified. For example:

```
insmod /lib/modules/<KERNEL_VERSION>/kernel/drivers/net/igb/igb.ko
```

In addition, when using 2.6-based kernels, make sure that older igb drivers are removed from the kernel before loading the new module. To do this, use:

```
rmmod igb; modprobe igb
```

6. Assign an IP address to the interface by entering the following with x as the interface number:

```
ifconfig ethx <IP_address> netmask <netmask>
```

7. Verify that the interface works. Enter the following, where <IP_address> is the IP address for another machine on the same subnet as the interface that is being tested:

```
ping <IP_address>
```

3.8 Installing the Drivers on FreeBSD (for Intel i350-AM4)

Follow the instructions to install the drivers to a FreeBSD kernel 4.8 or later. In the instructions below, x.x.x is the driver version as indicated in the name of the drive tar file.



Note: You must have kernel sources installed in order to compile the driver module.

1. Move the base driver tar file to the directory of your choice. For example, use

```
/home/username/igb or /usr/local/src/igb.
```

2. Untar/unzip the archive:

```
tar xzf igb-x.x.x directory
```

3. To install the main page:

```
cd igb-x.x.x  
gzip -c igb.4 > /usr/share/man/man4/igb.4.gz
```

4. To load the driver onto a running system, perform the following steps:

```
cd igb-x.x.x  
make
```

or

```
cd igb-x.x.x/src  
make load
```

5. To assign an IP address to the interface, enter the following:

```
ifconfig igb<interface_num> <IP_address>
```

6. Verify that the interface works. Enter the following, where <IP_address> is the IP address for another machine on the same subnet as the interface that is being tested:

```
ping <IP_address>
```

7. If you want the driver to load automatically when the system is booted:

```
cd igb-x.x.x/src
make load
cp if_igb.ko /modules
```

Edit `/boot/loader.conf`, and add the following line:

```
if_igb_load="YES"
```

or

compile the driver into the kernel (see item 8). Edit `/etc/rc.conf`, and create the appropriate `ifconfig_igb<interface_num>` entry:

```
ifconfig_igb<interface_num>="<ifconfig_settings>"
```

Example usage:

```
ifconfig_igb0="inet 192.168.10.1 netmask 255.255.255.0"
```

8. If you want to compile the driver into the kernel, enter:

```
cd igb-x.x.x/src
mkdir /usr/src/sys/dev/igb
cp if_igb* /usr/src/sys/dev/igb
cp igb* /usr/src/sys/dev/igb
cp Makefile.kernel /usr/src/sys/modules/igb/Makefile
```

Edit the `/usr/src/sys/conf/files.i386` file, and add the following line:

```
dev/igb/igb_hw.c optional igb
dev/igb/igb_ee.c optional igb
dev/igb/if_igb.c optional igb
```

Remove the following lines from the `/usr/src/sys/conf/files.i386` file, if they exist:

```
/dev/igb/if_igb_fx_hw.c optional igb
/dev/igb/if_igb_phy.c optional igb
```

Edit the kernel configuration file (i.e., GENERIC or MYKERNEL) in /usr/src/sys/i386/conf, and ensure the following line is present:

```
device igb
```

Compile and install the kernel. Then reboot the system for the kernel updates to take effect.

(Disclaimer Continued)

The products sold by Supermicro are not intended for and will not be used in life support systems, medical equipment, nuclear facilities or systems, aircraft, aircraft devices, aircraft/emergency communication devices or other critical systems whose failure to perform be reasonably expected to result in significant injury or loss of life or catastrophic property damage. Accordingly, Supermicro disclaims any and all liability, and should buyer use or sell such products for use in such ultra-hazardous applications, it does so entirely at its own risk. Furthermore, buyer agrees to fully indemnify, defend and hold Supermicro harmless for and against any and all claims, demands, actions, litigation, and proceedings of any kind arising out of or related to such ultra-hazardous use or sale.