



# AOC-XEH-i2M



## User's Guide

Revision 1.0a

---

The information in this User's Guide has been carefully reviewed and is believed to be accurate. The vendor assumes no responsibility for any inaccuracies that may be contained in this document, and makes no commitment to update or to keep current the information in this user's guide, or to notify any person or organization of the updates. **Please Note: For the most up-to-date version of this user's guide, please see our Website at [www.supermicro.com](http://www.supermicro.com).**

Super Micro Computer, Inc. ("Supermicro") reserves the right to make changes to the product described in this user's guide at any time and without notice. This product, including software and documentation, is the property of Supermicro and/or its licensors, and is supplied only under a license. Any use or reproduction of this product is not allowed, except as expressly permitted by the terms of said license.

IN NO EVENT WILL SUPER MICRO COMPUTER, INC. BE LIABLE FOR DIRECT, INDIRECT, SPECIAL, INCIDENTAL, SPECULATIVE OR CONSEQUENTIAL DAMAGES ARISING FROM THE USE OR INABILITY TO USE THIS PRODUCT OR DOCUMENTATION, EVEN IF ADVISED OF THE POSSIBILITY OF SUCH DAMAGES. IN PARTICULAR, SUPER MICRO COMPUTER, INC. SHALL NOT HAVE LIABILITY FOR ANY HARDWARE, SOFTWARE, OR DATA STORED OR USED WITH THE PRODUCT, INCLUDING THE COSTS OF REPAIRING, REPLACING, INTEGRATING, INSTALLING OR RECOVERING SUCH HARDWARE, SOFTWARE, OR DATA.

---

Any disputes arising between the manufacturer and the customer shall be governed by the laws of Santa Clara County in the State of California, USA. The State of California, County of Santa Clara shall be the exclusive venue for the resolution of any such disputes. Supermicro's total liability for all claims will not exceed the price paid for the hardware product.

---

FCC Statement: This equipment has been tested and found to comply with the limits for a Class A digital device pursuant to Part 15 of the FCC Rules. These limits are designed to provide reasonable protection against harmful interference when the equipment is operated in industrial environment. This equipment generates, uses, and can radiate radio frequency energy and, if not installed and used in accordance with the manufacturer's instruction manual, may cause harmful interference with radio communications. Operation of this equipment in a residential area is likely to cause harmful interference, in which case you will be required to correct the interference at your own expense.

---

California Best Management Practices Regulations for Perchlorate Materials: This Perchlorate warning applies only to products containing CR (Manganese Dioxide) Lithium coin cells. "Perchlorate Material-special handling may apply. See [www.dtsc.ca.gov/hazardouswaste/perchlorate](http://www.dtsc.ca.gov/hazardouswaste/perchlorate)".



**WARNING:** This product can expose you to chemicals including lead, known to the State of California to cause cancer and birth defects or other reproductive harm. For more information, go to [www.P65Warnings.ca.gov](http://www.P65Warnings.ca.gov).

The products sold by Supermicro are not intended for and will not be used in life support systems, medical equipment, nuclear facilities or systems, aircraft, aircraft devices, aircraft/emergency communication devices or other critical systems whose failure to perform be reasonably expected to result in significant injury or loss of life or catastrophic property damage. Accordingly, Supermicro disclaims any and all liability, and should buyer use or sell such products for use in such ultra-hazardous applications, it does so entirely at its own risk. Furthermore, buyer agrees to fully indemnify, defend and hold Supermicro harmless for and against any and all claims, demands, actions, litigation, and proceedings of any kind arising out of or related to such ultra-hazardous use or sale.

---

User's Guide Revision 1.0a

Release Date: August 12, 2020

Unless you request and receive written permission from Super Micro Computer, Inc., you may not copy any part of this document.

Information in this document is subject to change without notice. Other products and companies referred to herein are trademarks or registered trademarks of their respective companies or mark holders.

Copyright © 2020 by Super Micro Computer, Inc.  
All rights reserved.

**Printed in the United States of America**

## Preface

### About this User's Guide

This user's guide is written for system integrators, PC technicians, and knowledgeable PC users. It provides information for the installation and use of the AOC-XEH-i2M add-on card.

### About this Add-on Card

This product is sold only as part of an integrated solution with Supermicro server systems.

### An Important Note to the User

All images and layouts shown in this user's guide are based upon the latest PCB revision available at the time of publishing. The card you have received may or may not look exactly the same as the graphics shown in this user's guide.

### Returning Merchandise for Service

A receipt or copy of your invoice marked with the date of purchase is required before any warranty service will be rendered. You can obtain service by calling your vendor for a Returned Merchandise Authorization (RMA) number. When returning the add-on-card to the manufacturer, the RMA number should be prominently displayed on the outside of the shipping carton, and the shipping package is mailed prepaid or hand-carried. Shipping and handling charges will be applied for all orders that must be mailed when service is complete. For faster service, You can also request a RMA authorization online (<http://www.supermicro.com>).

This warranty only covers normal consumer use and does not cover damages incurred in shipping or from failure due to the alternation, misuse, abuse, or improper maintenance of products.

During the warranty period, contact your distributor first for any product problems.

## Conventions Used in the User's Guide

Pay special attention to the following symbols for proper system installation and to prevent damage to the system or injury to yourself:



**Note:** Additional information given to differentiate between various models or provides information for correct system setup.

## Naming Convention



Character	Representation	Options
1st	Product Family	<b>AOC:</b> Add On Card
2nd	Product Type/Speed	<b>GEH:</b> GbE (1Gb/s) <b>XEH:</b> 10GbE (10Gb/s) <b>B25G:</b> 25GbE (25Gb/s) <b>IBH:</b> Infiniband <b>OPH:</b> Omni-Path
3rd	Chipset	<b>X4D/6X4D:</b> Mellanox <sup>®</sup> ConnectX-4 Lx EN <b>X4ES:</b> Mellanox ConnectX-4 VPI <b>i2M:</b> Intel <sup>®</sup> Ethernet Controller X710-BM2 <b>I4M:</b> Intel Ethernet Controller I350-AM4 <b>IN2:</b> Intel Ethernet Controller 82599 <b>WFR:</b> Intel Omni-Path Wolfriver

## SMC Blade Networking Add-on Cards

Model	Type	Form Factor	Controller	Connection	Dimension (mm)	Power (W)	Where used
AOC-XEH-i2M	10GbE	Proprietary	Intel Ethernet Controller X710-BM2	2x 10GbE	76.58 x 46.56	3.04W typical, 5.63W max	Microblade 3U/6U
AOC-GEH-I4M	1GbE	Proprietary	Intel Ethernet Controller I350-AM4	4x 1GbE	76.58 x 46.56	2.1W typical, 2.6W max	Microblade 3U/6U
AOC-IBH-X4ES	EDR IB	Proprietary	Mellanox ConnectX-4 VPI	1x 100Gb/s InfiniBand port	75.1 x 133.5	12.5W typical, 14.6W max	Superblade 8U (SBE-820C)
AOC-XEH-IN2	10GbE	Proprietary	Intel Ethernet Controller 82599	2x 10GbE	71.35 x 59.5	6.25W max	Superblade 7U
AOC-OPH-WFR	Omni-Path	Proprietary	Intel Omni-Path Wolfriver	1x 100Gb/s	75.1 x 133.5	13.12W typical, 16.65W max	Superblade 8U (SBE-820C)
AOC-B25G-X4D	25GbE	Proprietary	Mellanox ConnectX-4 Lx EN	2x 25GbE or 10GbE	75.1 x 133.5	12.5W typical, 14.6W max	Superblade 8U (SBE-820J)
AOC-B25G-6X4D	25GbE	Proprietary	Mellanox ConnectX-4 Lx EN	2x 25GbE or 10GbE	73.5 x 87	12.5W typical, 14.6W max	Superblade 6U (SBE-610J)

## Contacting Supermicro

### Headquarters

Address: Super Micro Computer, Inc.  
980 Rock Ave.  
San Jose, CA 95131 U.S.A.

Tel: +1 (408) 503-8000

Fax: +1 (408) 503-8008

Email: [marketing@supermicro.com](mailto:marketing@supermicro.com) (General Information)  
[support@supermicro.com](mailto:support@supermicro.com) (Technical Support)

Website: [www.supermicro.com](http://www.supermicro.com)

### Europe

Address: Super Micro Computer B.V.  
Het Sterrenbeeld 28, 5215 ML  
's-Hertogenbosch, The Netherlands

Tel: +31 (0) 73-6400390

Fax: +31 (0) 73-6416525

Email: [sales@supermicro.nl](mailto:sales@supermicro.nl) (General Information)  
[support@supermicro.nl](mailto:support@supermicro.nl) (Technical Support)  
[rma@supermicro.nl](mailto:rma@supermicro.nl) (Customer Support)

Website: [www.supermicro.com](http://www.supermicro.com)

### Asia-Pacific

Address: Super Micro Computer, Inc.  
3F, No. 150, Jian 1st Rd.  
Zhonghe Dist., New Taipei City 235  
Taiwan (R.O.C)

Tel: +886-(2) 8226-3990

Fax: +886-(2) 8226-3992

Email: [support@supermicro.com.tw](mailto:support@supermicro.com.tw)

Website: [www.supermicro.com.tw](http://www.supermicro.com.tw)

# Table of Contents

## **Preface**

About this User's Guide .....	iii
About this Add-on Card .....	iii
An Important Note to the User .....	iii
Returning Merchandise for Service .....	iii
Conventions Used in the User's Guide .....	iv
Naming Convention .....	iv
SMC Blade Networking Add-on Cards .....	iv
Contacting Supermicro .....	v

## **Chapter 1 Overview**

1-1 Overview .....	1-1
1-2 Key Features .....	1-1
1-3 Specifications .....	1-2
General .....	1-2
I/O Features .....	1-2
Virtualization Features .....	1-2
Storage Interface Features .....	1-3
Management Features .....	1-3
Advanced Software Features .....	1-3
Power Consumption .....	1-3
Operating Conditions .....	1-4
Physical Dimensions .....	1-4
Supported Platforms .....	1-4
1-4 Available SKUs .....	1-4

## **Chapter 2 Hardware Components**

2-1 Add-On Card Images and Layout .....	2-1
2-2 Major Components .....	2-2

## **Chapter 3 Installation**

3-1 Static-Sensitive Devices .....	3-1
Precautions .....	3-1
Unpacking .....	3-1
3-2 Before Installation .....	3-2
3-3 Add-on Card Installation .....	3-2
3-4 Installing Drivers on Windows .....	3-4
3-5 Installing Drivers on Linux <sup>®</sup> .....	3-5
Build a Binary RPM Package .....	3-5
3-6 Installing Drivers on FreeBSD <sup>®</sup> .....	3-6

# Chapter 1

## Overview

### 1-1 Overview

Congratulations on purchasing your add-on card from an acknowledged leader in the industry. Supermicro products are designed with the utmost attention to detail to provide you with the highest standards in quality and performance. For product support and updates, please refer to our website at <http://www.supermicro.com/products/nfo/networking.cfm#adapter>.

### 1-2 Key Features

The key features of this add-on card include:

- Supermicro Blade Mezzanine Card
- Intel Ethernet Controller X710-BM2, supporting two 10G ports
- Network Virtualization Offloads including VXLAN and NVGRE
- Small packet performance
- Data Plane Developer Kit for efficient packet processing
- Low power consumption
- Intel Flow Director
- Intelligent Offloads
- Unified networking providing a single wire support for LAN and storage
- Asset Management features
- RoHS compliant 6/6 

## 1-3 Specifications

### General

- Supermicro Blade Mezzanine Card
- Intel Ethernet Controller X710-BM2, supporting two 10G ports
- Load balancing on multiple CPUs
- Intel PROSet Utility for Windows® Device Manager
- Time Sync (IEEE 1588)
- Energy Efficient Ethernet (EEE)

### I/O Features

- Intel Flow Director
- MSI-X support
- Multiple Queues: 1,536 TX and RX queues per port
- Tx/Rx IP, SCTP, TCP, and UDP checksum offloading (IPv4, IPv6) capabilities
- Jumbo Frame (9.5KB)

### Virtualization Features

- Next-Generation VMDq with up to 256 VMDq VMs supported
- PCI-SIG SR-IOV with up to 128 virtual ports
- Virtual Machine Load Balancing (VMLB)
- Advanced Packet Filtering
- VLAN support for up to 4096 VLAN tags
- VXLAN and NVGRE support

## **Storage Interface Features**

- Preboot eXecution Environment (PXE) support
- iSCSI remote boot
- Simple Network Management Protocol (SNMP) and Remote Network Monitoring (RMON) static counters

## **Management Features**

- Asset Management support on Supermicro platforms
- Controller asset tags such as part number, revision, serial number, and MAC addresses
- Controller thermal sensor
- NC-SI for remote management

## **Advanced Software Features**

- Teaming support
- IEEE 802.3ad (link aggregation control protocol)
- IEEE 802.1Q VLANs
- IEEE 802.3 2005 flow control support
- TCP segmentation/large send offload
- Interrupt moderation

## **Power Consumption**

- Typical power consumption: 3.04W
- Maximum power consumption: 5.63W

## Operating Conditions

- Operating temperature: 0°C to 55°C (32°F to 131°F)
- Storage temperature: -40°C to 70°C (-40°F to 158°F)
- Storage humidity: 90% non-condensing relative humidity at 35°C

## Physical Dimensions

- Card PCB dimensions: 76.58mm (3.02in) x 46.56mm (1.83in) (W x D)

## Supported Platforms

- Supermicro<sup>®</sup> MicroBlade motherboard with mezzanine slot



**Note:** This product is sold only as part of an integrated solution with Supermicro server systems.

## 1-4 Available SKUs

SKUs	Part Number	Description
AOC-XEH-i2M	AOC-XEH-i2M	2-port 10 Gigabit Ethernet Adapter

## Chapter 2

### Hardware Components

#### 2-1 Add-On Card Images and Layout

##### Images of AOC-XEH-i2M

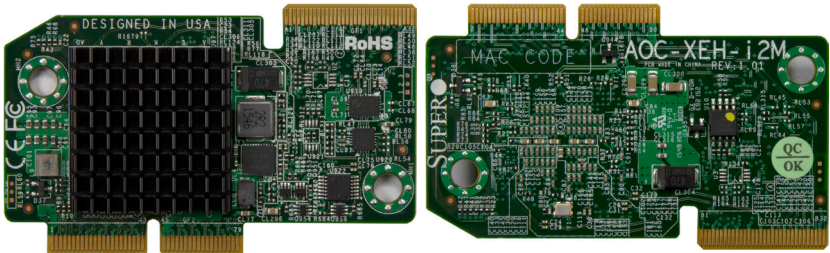

Top View

Bottom View

##### Layout of AOC-XEH-i2M

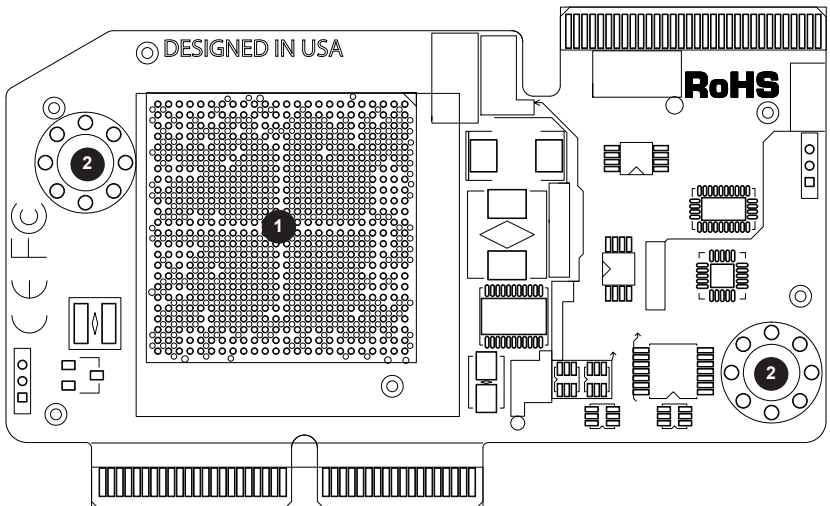

1. Intel X710-BM2

2. Mounting Holes

## **2-2 Major Components**

The following major components are built-in on the AOC-XEH-i2M:

1. One (1) Intel X710-BM2 controller
2. Two (2) Mounting Holes

## Chapter 3

### Installation

#### 3-1 Static-Sensitive Devices

Electrostatic Discharge (ESD) can damage electronic components. To avoid damaging your add-on card, it is important to handle it very carefully. The following measures are generally sufficient to protect your equipment from ESD.

##### Precautions

- Use a grounded wrist strap designed to prevent static discharge.
- Touch a grounded metal object before removing the add-on card from the antistatic bag.
- Handle the add-on card by its edges only; do not touch its components.
- Put the add-on card back into the antistatic bags when not in use.
- For grounding purposes, make sure that your system chassis provides excellent conductivity between the power supply, the case, the mounting fasteners and the add-on card.

##### Unpacking

The add-on card is shipped in antistatic packaging to avoid static damage. When unpacking your component or system, make sure you are static protected.



**Note:** To avoid damaging your components and to ensure proper installation, always connect the power cord last, and always unplug it before adding, removing, or changing any hardware components.

## 3-2 Before Installation

Before you install the add-on card, follow the instructions below.

1. Use industry-standard anti-static equipment such as gloves or a wrist strap and follow the precautions on [page 3-1](#) to avoid damage caused by ESD.
2. Familiarize yourself with the server, motherboard, and/or chassis documentation.
3. Confirm that your operating system includes the latest updates and hotfixes.

## 3-3 Add-on Card Installation

Follow the steps below to install the add-on card into your system.

**Note:** This add-on card does not support hot plug.

1. Remove the CPU Blade from the enclosure.
2. Remove the motherboard from the chassis, and set the screws aside for later use.
3. Position the add-on card in front of the corresponding slot on the motherboard and gently push the card until it slides into the slot.
4. Insert the screws into the add-on card's and motherboard's mounting holes.
5. Secure the add-on card and motherboard to the chassis using the screws.  
**Note:** To avoid the motherboard being damaged, **DO NOT** overtighten the screws.

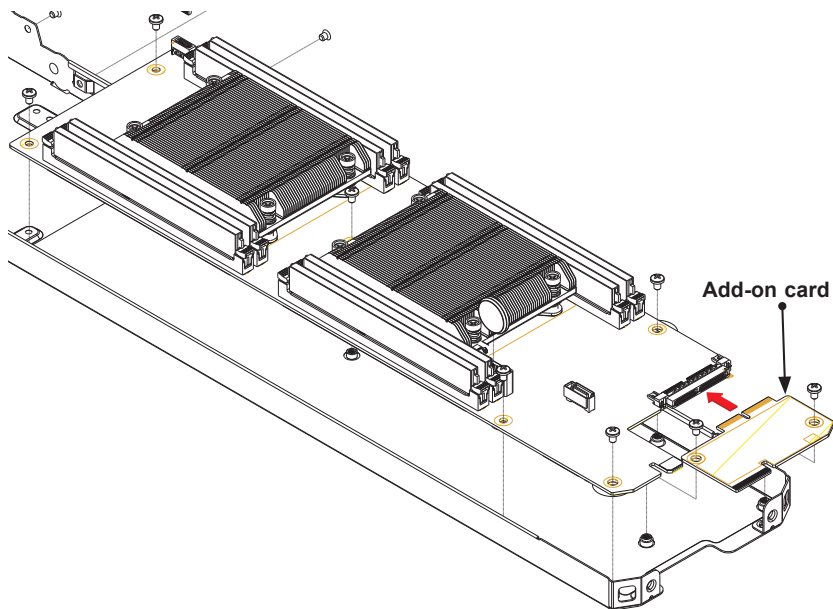

**Figure 3-1. Installing the Add-on Card**

6. Re-insert the CPU Blade into the enclosure.

### 3-4 Installing Drivers on Windows

Follow the steps below to install the drivers for Windows. Download the drivers from the Supermicro website at <https://www.supermicro.com/wftp/driver>.

1. Run CDR-NIC.
2. When the SUPERMICRO window appears, click on the computer icon next to Intel 10GbE Adapter.

**Note:** If the *FOUND NEW HARDWARE WIZARD* screen displays on your system, click CANCEL.

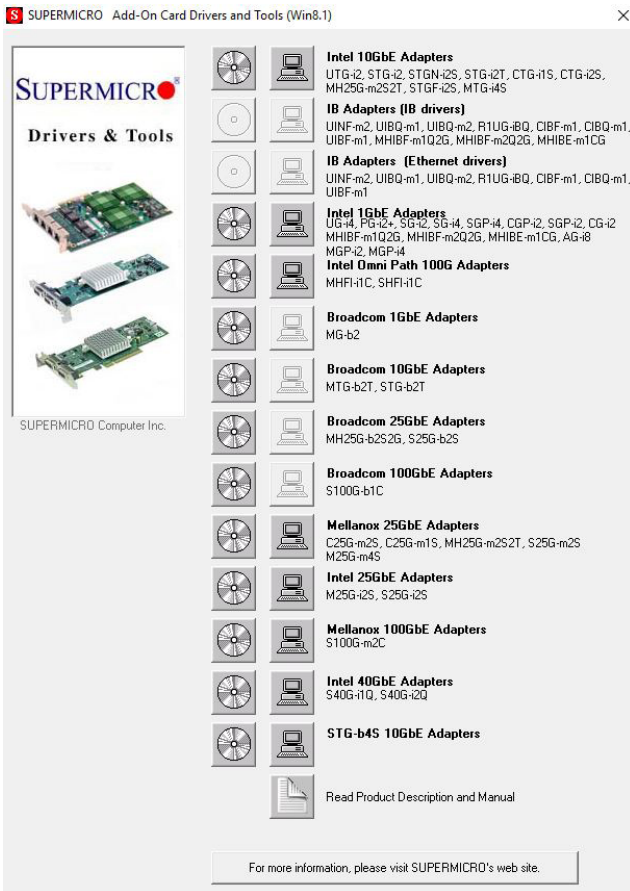

3. Click on INSTALL DRIVERS AND SOFTWARE.
4. Follow the prompts to complete the installation.

### 3-5 Installing Drivers on Linux®

Follow the steps below to install the drivers in Linux.

#### Build a Binary RPM Package

1. Run 'rpmbuild -tb <filename.tar.gz>'
2. Replace <filename.tar.gz> with the specific filename of the driver.

**Note:** For the build to work properly, the current running kernel MUST match the version and configuration of the installed kernel sources. If you have just recompiled the kernel, reboot the system at this time.

Follow the instructions below to build the driver manually.

1. Move the base driver tar file to the directory of your choice. For example:

```
/home/username/ixgbe
```

or

```
/usr/local/src/ixgbe
```

2. Untar/unzip archive, where <x.x.x> is the version number for the driver tar file:

```
tar xzf ixgbe-x.x.x.tar.gz
```

3. Change to the driver src directory, where <x.x.x> is the version number for the driver tar:

```
cd ixgbe-x.x.x/src/
```

4. Compile the driver module:

```
make install
```

The binary will be installed as:

```
/lib/modules/[KERNEL_VERSION]/kernel/drivers/net/ixgbe/ixgbe.[k]o
```

The install locations listed above are the default locations. They may not be correct for certain Linux distributions. For more information, see the `ldistrib.txt` file included in the driver tar.

**Note:** `IXGBE_NO_LRO` is a compile time flag. The user can enable it at compile time to remove support for LRO from the driver. The flag is used by adding `CFLAGS_EXTRA="-DIXGBE_NO_LRO"` to the make file when it's being compiled.

```
make CFLAGS_EXTRA="-DIXGBE_NO_LRO" install
```

5. Load the module:

For kernel 2.6.x, use the `modprobe` command:

```
modprobe ixgbe <parameter>=<value>
```

For 2.6 kernels, the `insmod` command can be used if the full path to the driver module is specified. For example:

```
insmod /lib/modules/<KERNEL_VERSION>/kernel/drivers/net/  
ixgbe/ixgbe.ko
```

In addition, when using 2.6-based kernels, make sure that older `ixgbe` drivers are removed from the kernel before loading the new module. To do this, use:

```
rmmod ixgbe; modprobe ixgbe
```

6. Assign an IP address to the interface by entering the following, where `x` is the interface number:

```
ifconfig ethx <IP_address> netmask <netmask>
```

7. Verify that the interface works. Enter the following, where `<IP_address>` is the IP address for another machine on the same subnet as the interface that is being tested:

```
ping <IP_address>
```

## 3-6 Installing Drivers on FreeBSD®

Follow the instructions below to install the drivers in FreeBSD kernel 4.8 or later. In the instructions below, `x.x.x` is the driver version as indicated in the name of the drive tar file.

**Note:** You must have kernel sources installed in order to compile the driver module.

1. Move the base driver tar file to the directory of your choice. For example, use `/home/username/ixgb` or `/usr/local/src/ixgb`.

2. Untar/unzip the archive:

```
tar xfz ixgb-x.x.x directory
```

3. To install man page:

```
cd ixgb-x.x.x
```

```
gzip -c ixgb.4 > /usr/share/man/man4/ixgb.4.gz
```

4. To load the driver onto a running system, perform the following steps:

```
cd ixgb-x.x.x
```

```
make
```

or

```
cd ixgb-x.x.x/src
```

```
make load
```

5. To assign an IP address to the interface, enter the following:

```
ifconfig ixgb<interface_num> <IP_address>
```

6. Verify that the interface works. Enter the following, where `<IP_address>` is the IP address for another machine on the same subnet as the interface that is being tested:

```
ping <IP_address>
```

7. If you want the driver to load automatically when the system is booted:

```
cd ixgb-x.x.x/src
```

```
make load
```

```
cp if_ixgb.ko /modules
```

Edit `/boot/loader.conf`, and add the following line:

```
if_ixgb_load="YES"
```

or

compile the driver into the kernel (see item 8). Edit `/etc/rc.conf`, and create the appropriate `ifconfig_ixgb<interface_num>` entry:

```
ifconfig_ixgb<interface_num>="<ifconfig_settings>"
```

Example usage:

```
ifconfig_ixgb0="inet 192.168.10.1 netmask 255.255.255.0"
```

8. If you want to compile the driver into the kernel, enter:

```
cd ixgb-x.x.x/src
mkdir /usr/src/sys/dev/ixgb
cp if_ixgb* /usr/src/sys/dev/ixgb
cp ixgb* /usr/src/sys/dev/ixgb
cp Makefile.kernel /usr/src/sys/modules/ixgb/Makefile
```

Edit the `/usr/src/sys/conf/files.i386` file, and add the following line:

```
dev/ixgb/ixgb_hw.c optional ixgb
dev/ixgb/ixgb_ee.c optional ixgb
dev/ixgb/if_ixgb.c optional ixgb
```

Remove the following lines from the `/usr/src/sys/conf/files.i386` file if they exist:

```
/dev/ixgb/if_ixgb_fx_hw.c optional ixgb
/dev/ixgb/if_ixgb_phy.c optional ixgb
```

Edit the kernel configuration file (i.e., `GENERIC` or `MYKERNEL`) in `/usr/src/sys/i386/conf`, and ensure the following line is present:

```
device ixgb
```

Compile and install the kernel. Reboot the system for the kernel updates to take effect.