

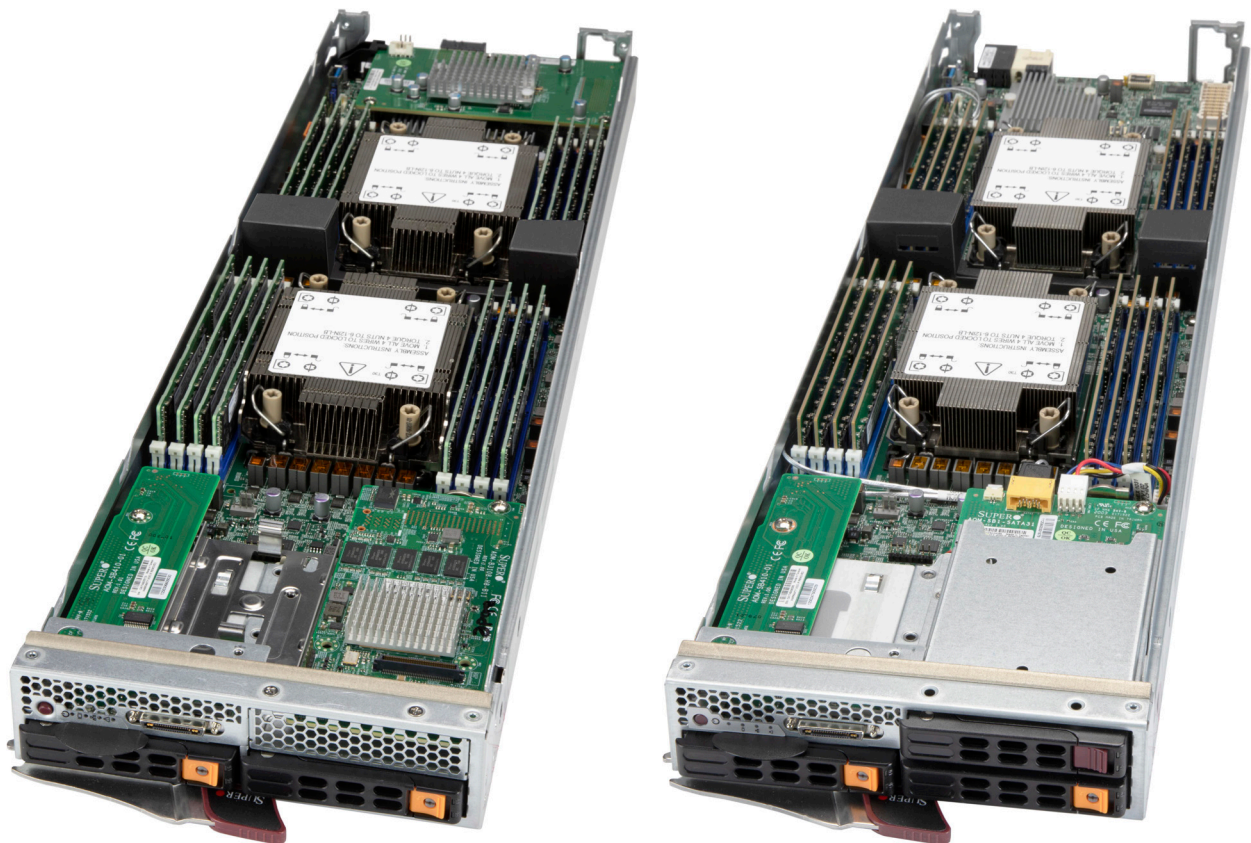

SUPERBLADE SERVER

SBI-420P-1C2N SBI-420P-1T3N



USER'S MANUAL

Revision 1.0a

The information in this User's Manual has been carefully reviewed and is believed to be accurate. The vendor assumes no responsibility for any inaccuracies that may be contained in this document, and makes no commitment to update or to keep current the information in this manual, or to notify any person or organization of the updates. Please Note: For the most up-to-date version of this manual, please see our website at www.supermicro.com.

Super Micro Computer, Inc. ("Supermicro") reserves the right to make changes to the product described in this manual at any time and without notice. This product, including software and documentation, is the property of Supermicro and/or its licensors, and is supplied only under a license. Any use or reproduction of this product is not allowed, except as expressly permitted by the terms of said license.

IN NO EVENT WILL Super Micro Computer, Inc. BE LIABLE FOR DIRECT, INDIRECT, SPECIAL, INCIDENTAL, SPECULATIVE OR CONSEQUENTIAL DAMAGES ARISING FROM THE USE OR INABILITY TO USE THIS PRODUCT OR DOCUMENTATION, EVEN IF ADVISED OF THE POSSIBILITY OF SUCH DAMAGES. IN PARTICULAR, SUPER MICRO COMPUTER, INC. SHALL NOT HAVE LIABILITY FOR ANY HARDWARE, SOFTWARE, OR DATA STORED OR USED WITH THE PRODUCT, INCLUDING THE COSTS OF REPAIRING, REPLACING, INTEGRATING, INSTALLING OR RECOVERING SUCH HARDWARE, SOFTWARE, OR DATA.

Any disputes arising between manufacturer and customer shall be governed by the laws of Santa Clara County in the State of California, USA. The State of California, County of Santa Clara shall be the exclusive venue for the resolution of any such disputes. Supermicro's total liability for all claims will not exceed the price paid for the hardware product.

FCC Statement: This equipment has been tested and found to comply with the limits for a Class A or Class B digital device pursuant to Part 15 of the FCC Rules. These limits are designed to provide reasonable protection against harmful interference when the equipment is operated in industrial environment for Class A device or in residential environment for Class B device. This equipment generates, uses, and can radiate radio frequency energy and, if not installed and used in accordance with the manufacturer's instruction manual, may cause harmful interference with radio communications. Operation of this equipment in a residential area is likely to cause harmful interference, in which case you will be required to correct the interference at your own expense.

California Best Management Practices Regulations for Perchlorate Materials: This Perchlorate warning applies only to products containing CR (Manganese Dioxide) Lithium coin cells. "Perchlorate Material-special handling may apply. See www.dtsc.ca.gov/hazardouswaste/perchlorate".



WARNING: This product can expose you to chemicals including lead, known to the State of California to cause cancer and birth defects or other reproductive harm. For more information, go to www.P65Warnings.ca.gov.

The products sold by Supermicro are not intended for and will not be used in life support systems, medical equipment, nuclear facilities or systems, aircraft, aircraft devices, aircraft/emergency communication devices or other critical systems whose failure to perform be reasonably expected to result in significant injury or loss of life or catastrophic property damage. Accordingly, Supermicro disclaims any and all liability, and should buyer use or sell such products for use in such ultra-hazardous applications, it does so entirely at its own risk. Furthermore, buyer agrees to fully indemnify, defend and hold Supermicro harmless for and against any and all claims, demands, actions, litigation, and proceedings of any kind arising out of or related to such ultra-hazardous use or sale.

Manual Revision 1.0

Release Date: February 16,2024

mk

Unless you request and receive written permission from Super Micro Computer, Inc., you may not copy any part of this document. Information in this document is subject to change without notice. Other products and companies referred to herein are trademarks or registered trademarks of their respective companies or mark holders.

Copyright © 2021 by Super Micro Computer, Inc.
All rights reserved.

Printed in the United States of America

Preface

About this Manual

This manual is written for professional system integrators and PC technicians. It provides information for the installation and use of this blade server. Installation and maintenance should be performed by experienced technicians only.

Please refer to the SBI-420P-1(C2/T3)N specifications page on our website for updates on supported memory, processors and operating systems (<http://www.supermicro.com>).

Notes

For your system to work properly, download all necessary drivers/utilities and the user's manual for your server.

- Supermicro product manuals: <http://www.supermicro.com/support/manuals/>
- Product drivers and utilities: <https://www.supermicro.com/wftp>
- Product safety info: http://www.supermicro.com/about/policies/safety_information.cfm

If you have any questions, contact our support team at: support@supermicro.com

This manual may be periodically updated without notice. Check the Supermicro website for possible updates to the manual revision level.

Secure Data Deletion

A secure data deletion tool designed to fully erase all data from storage devices can be found on our website: https://www.supermicro.com/about/policies/disclaimer.cfm?url=/wftp/utility/Lot9_Secure_Data_Deletion_Utility/

Warnings

Special attention should be given to the following symbols used in this manual.



Warning! Indicates important information given to prevent equipment/property damage or personal injury.



Warning! Indicates high voltage may be encountered when performing a procedure.

Contents

Chapter 1 Introduction

1.1 Overview.....	7
Eligible Enclosures.....	7
1.2 System Features	8
1.3 Front View	9
Control Panel	10
1.4 Components	11

Chapter 2 Installation and Setup

2.1 Unpacking the System	13
2.2 Installing or Removing the Blade Unit.....	14
Installing a Blade Unit into the Enclosure.....	14
Removing a Blade Unit from the Enclosure	14
Removing and Replacing the Blade Cover.....	15
2.3 Powering Up or Down	16
Powering Up a Blade Unit.....	16
Powering Down a Blade Unit.....	16
2.4 Processor and Heatsink Installation.....	17
The Processor Carrier Assembly	18
The Processor Heatsink Module (PHM)	20
Installing the PHM into the CPU Socket.....	21
Removing the PHM from the CPU Socket	24
Removing the Processor Carrier Assembly from the PHM	25
Removing the Processor from the Carrier Assembly.....	26
2.5 Memory.....	27
Memory Support.....	27
Memory Population Guidelines	30
Guidelines Regarding Mixing DIMMs	30
DIMM Construction	30
Memory Population Sequence	30
Installing Memory.....	31
2.6 Storage Drives.....	32
Drive Carrier Indicators	32
Hot-Swap for NVMe Drives.....	35

Checking the Temperature of an NVMe Drive	36
M.2 Solid State Drives	37
2.7 Installing the Operating System	38
Linux Installation with Two Storage Drives	39
2.8 Configuring and Setting up RAID.....	39
2.9 Driver Installation.....	40
Chapter 3 Management and Maintenance	
3.1 Management Software	41
IPMI	41
BMC ADMIN User Password.....	41
3.2 Motherboard Battery.....	42
3.3 System Cooling	43
Installing the Air Shrouds	43
Checking the Server Air Flow	44
Overheating	44
3.4 CMOS Clear	44
3.5 Where to Get Replacement Components	45
3.6 Returning Merchandise for Service.....	45
Chapter 4 Motherboard Connections	
4.1 Motherboard Layout	46
Chipset Block Diagram.....	48
4.2 Power Connections	49
4.3 Headers and Connectors	49
4.4 Jumpers.....	51
Explanation of Jumpers	51
4.5 LED Indicators.....	52
Chapter 5 UEFI BIOS	
5.1 Introduction.....	53
Starting BIOS Setup Utility.....	53
5.2 Main Setup	53
5.3 Tab Pages	55
Appendix A BIOS POST Codes	
Appendix B Standardized Warning Statements for AC Systems	
Appendix C CPU-Based RAID for NVMe	
Appendix D Specifications and Compliance Statements	

Contacting Supermicro

Headquarters

Address: Super Micro Computer, Inc.
980 Rock Ave.
San Jose, CA 95131 U.S.A.

Tel: +1 (408) 503-8000

Fax: +1 (408) 503-8008

Email: marketing@supermicro.com (General Information)
support@supermicro.com (Technical Support)

Website: www.supermicro.com

Europe

Address: Super Micro Computer B.V.
Het Sterrenbeeld 28, 5215 ML
's-Hertogenbosch, The Netherlands

Tel: +31 (0) 73-6400390

Fax: +31 (0) 73-6416525

Email: sales@supermicro.nl (General Information)
support@supermicro.nl (Technical Support)
rma@supermicro.nl (Customer Support)

Website: www.supermicro.nl

Asia-Pacific

Address: Super Micro Computer, Inc.
3F, No. 150, Jian 1st Rd.
Zhonghe Dist., New Taipei City 235
Taiwan (R.O.C)

Tel: +886-(2) 8226-3990

Fax: +886-(2) 8226-3992

Email: support@supermicro.com.tw

Website: www.supermicro.com.tw

Chapter 1

Introduction

1.1 Overview

The SBI-420P-1(C2/T3)N blade is a compact self-contained server that connects into a pre-cabled enclosure that provides power, cooling, management and networking functions. One 8U enclosure can hold up to twenty blades. Each blade contains one computing node.

In this manual, “blade” or “blade unit” refers to a single blade, and “blade enclosure” is the chassis that houses the blades, power supplies and other modules. “Blade system” refers to the enclosure, blades units, and various management and networking modules.

This chapter outlines of the functions and features.

Models		
System	Storage Type	Add-on Module
SBI-420P-1T3N	SATA/NVMe hybrid ports	AOM-SB1-SATA31
SBI-420P-1C2N	SAS/NVMe hybrid ports	AOM-B3108-H8-B11

In addition, several important parts are listed below.

Main Parts List		
Description	Part Number	Quantity
Motherboard	B12DPT-6	1
Blade chassis	MCP-680-41001-0N	1
Add-on card, front control board	AOM-SB410-01	1
Air Shroud	MCP-310-41008-0N	1
License key for OOB BIOS	SFT-OOB-LIC	1
CPU heatsink, passive	SNK-P1044V	2
<i>(optional)</i> Mezzanine add-on card, Omnipath, 100Gbps	AOC-OPH-WFR	1*
<i>(optional)</i> Mezzanine add-on card, M.2 support	AOM-B-4M	1*
<i>(optional)</i> Mezzanine add-on card, Infiniband EDR	AOC-IBH-X4ESO	1*
<i>(optional; SBI-420P-1T3N only)</i> Mezzanine add-on card, two-port 25GbE	AOC-B25G-M2SP	1*

*Mutually exclusive—only one mezzanine card can be installed.

Eligible Enclosures

- SBE-820C-[4/6/8]22
- SBE-820H-[4/6/8]22
- SBE-820J-[4/6/8]22
- SBE-820L-[4/6/8]22

1.2 System Features

The following is an overview of the main features of the SBI-420P-1(C2/T3)N blade server.

System Features
Motherboard
B12DPT-6
CPU
Dual Intel Xeon 3rd Gen Scalable processors (in Socket P4 LGA4189) with up to 38 cores and a thermal design power (TDP) of up to 270W; for the updates, refer to our website at Supermicro.com
Chipset
Intel C621A
Memory
Sixteen slots for up to 2TB of 3DS LRDIMM/LRDIMM/3DS RDIMM/RDIMM DDR4 ECC memory with speeds of 3200/2933/2666MT/s; DIMM size up to 128G at 1.2V
Storage Drives
SBI-420P-1C2N: Two hot-swap 2.5" SAS or NVMe SBI-420P-1T3N: Two hot-swap 2.5"SATA or NVMe, and one hot-swap 2.5" SATA One M.2 SSD; an optional add-on module can provide four additional M.2 SSDs
BIOS
256Mb SPI Flash EEPROM with AMI BIOS
LAN Connections
Two 25GbE onboard; an optional mezzanine card can provide two additional 25GbE, EDR, HDR, or OPA
Form Factor
4U (WxHxD) 1.75 x 6.5 x 23.5 in. (44.5 x 165 x 597 mm)

1.3 Front View

The illustration below shows the features on the front of the blade unit.



Figure 1-1. Front View, SBI-420P-1T3N

Chassis Front Features		
Item	Features	Description
1	Control Panel	Power button and status indicators
2	Storage Drives	Two hot-swap 2.5" drive bays for NVME, SAS, or SATA; the drive carriers display status lights
3	Storage Drive	SBI-420P-1T3N only; one hot-swap 2.5" drive bay for SATA
4	KVM	Keyboard, video, mouse connector
5	Service/Asset Tag	Pull-out identifier (with BMC ADMIN default password sticker)

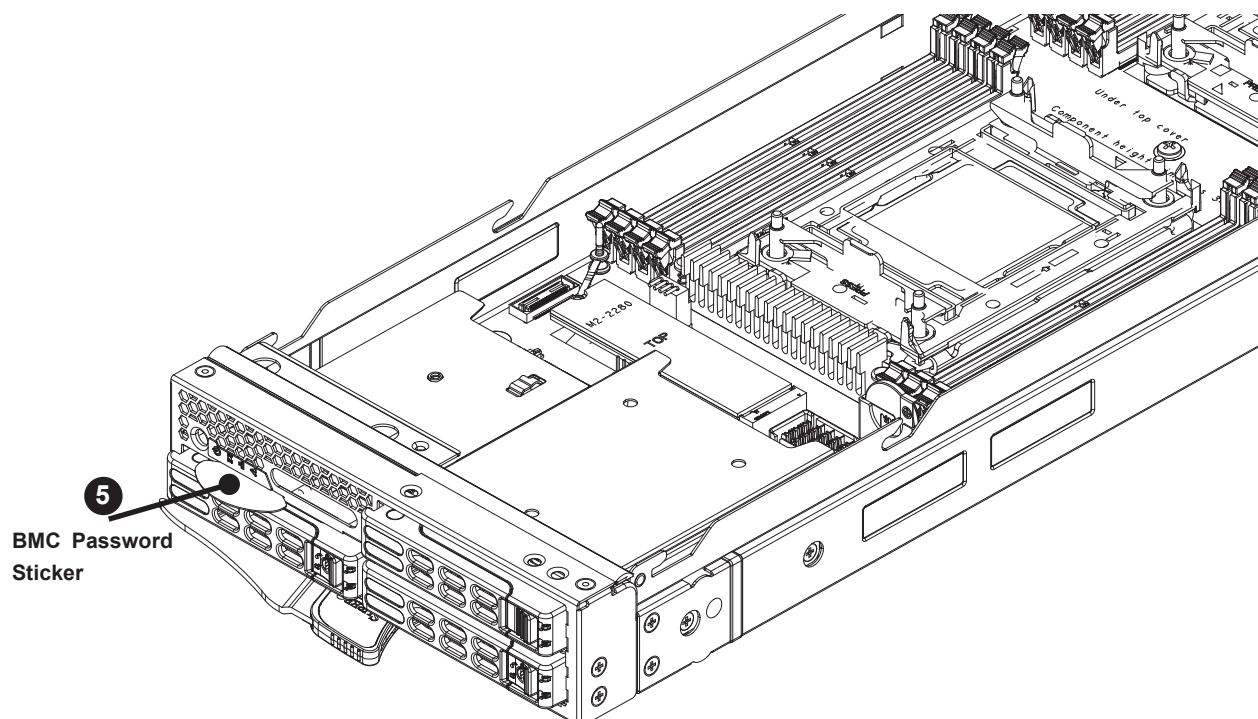

Figure 1-2. Location of the BMC Password Label

Control Panel

Power switches and status LEDs are located on the control panel on the front of the chassis.

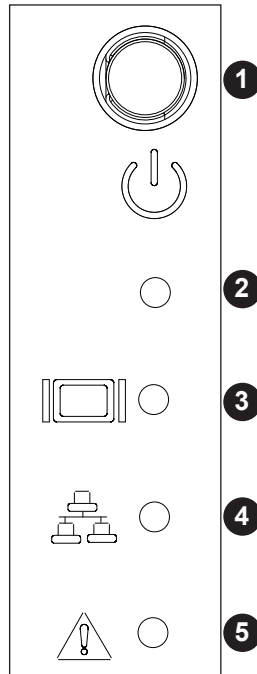
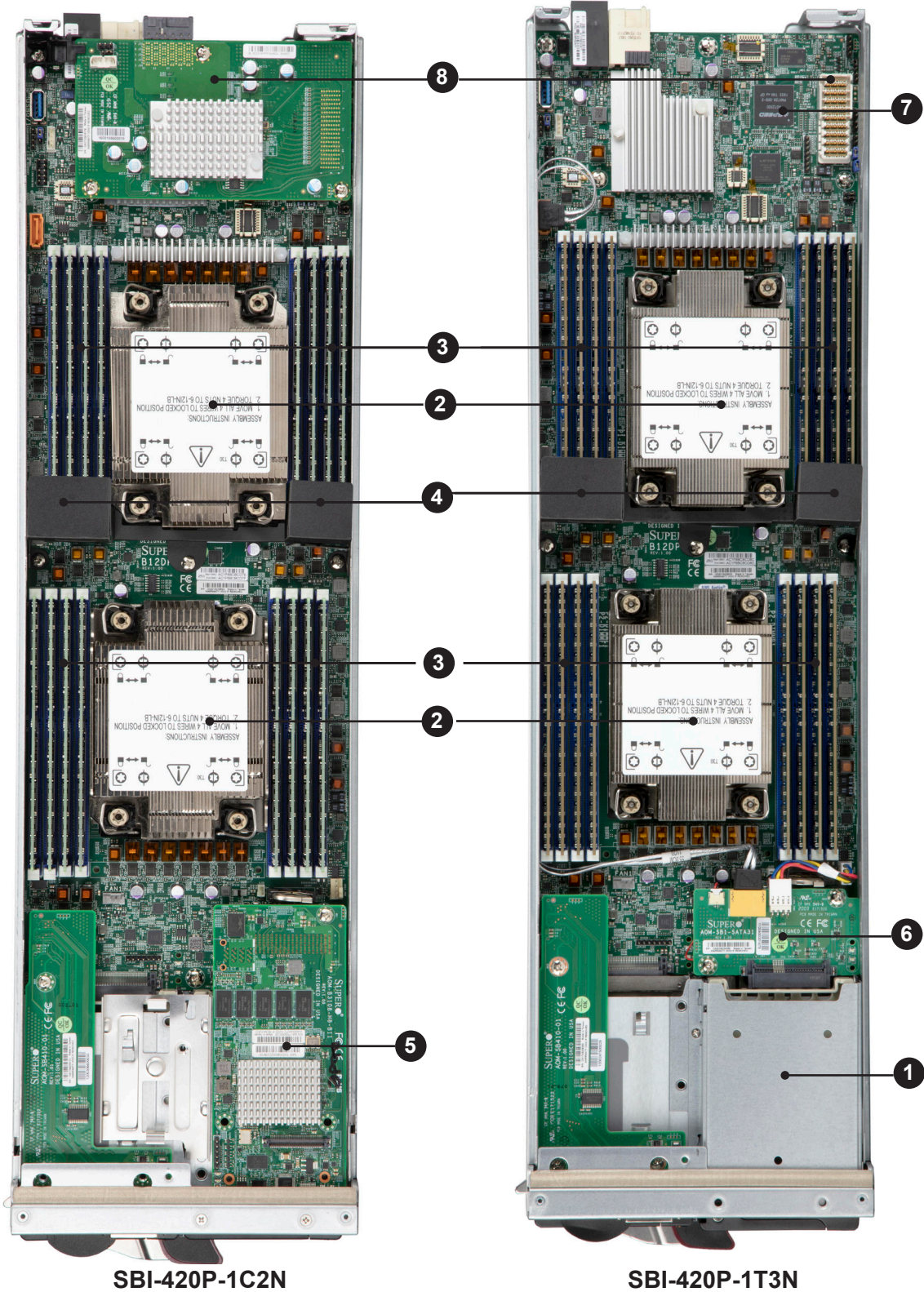

Figure 1-3. Control Panel

Control Panel Features			
Item	Feature	State	Description
1	Power button		The main power switch applies or removes primary power from the power supply to the server but maintains standby power.
2	Power LED	Green	Power on
		Flashing amber	Before the BMC is ready, blinks until every node is ready
3	KVM/UID LED	Steady blue	Indicates that KVM has been initialized
		Flashing blue	Unit Identifier indicator (The UID function is activated with a management program.)
4	NIC LED	Flashing green	Indicates traffic (Tx and RX data) on the LAN connection to this blade module
		Flashing orange	Indicates traffic over the network (when present in the system)
5	System Fail LED	Red	Indicates a fatal error. This may be a memory error or any other error that prevents the operating system from booting.

1.4 Components



SBI-420P-1C2N

SBI-420P-1T3N

Figure 1-4. Components Labeled (see next page)

Blade Components		
Item	Feature	Description
1	Drive	SBI-420P-1T3N only; 2.5" SATA storage drive
2	CPU	Processor and heatsink
3	Memory	DIMM slots
4	Air Shrouds	Direct air flow
5	Module	SBI-420P-1C2N only; enables Broadcom 3108 RAID controller
6	Module	SBI-420P-1T3N only; provides SATA for third drive
7	Chipset	Motherboard chipset
8	Mezzanine	Add-on card provides one of: EDR, HDR, M.2 storage, Omnipath 100Gbps, or 25GbE network speed; see Section 1.1 for more details; for SBI-420P-1T3N, the mezzanine connector is shown

Chapter 2

Installation and Setup

This chapter provides instructions on installing and replacing user-replaceable components. To prevent compatibility issues, use only components that match the specifications or parts qualified by Supermicro.

Up to twenty blade modules may be installed into a blade enclosure. Blade modules with different operating systems, such as Windows and Linux, may be mixed together in the same blade enclosure.

2.1 Unpacking the System

Inspect the box the system was shipped in and note if it was damaged in any way. If any equipment appears damaged, please file a damage claim with the carrier who delivered it.

Decide on a suitable location for the rack unit that will hold the enclosure. It should be situated in a clean, dust-free area that is well ventilated. Avoid areas where heat, electrical noise and electromagnetic fields are generated. It will also require a grounded AC power outlet nearby. Be sure to read the precautions and considerations noted in Appendix B.

2.2 Installing or Removing the Blade Unit

Installing a Blade Unit into the Enclosure

Make sure the cover of the blade unit is on before insertion.

Installing a Blade Unit into the Enclosure

1. Pull open the blade locking handle and slowly push the blade into its bay.
2. After the blade is seated in the enclosure, push the handle into its locked position, making sure the notch in the handle catches the lip of the enclosure.

Caution: Insert the blade with caution so the rear connectors are not damaged. If mezzanine connectors are installed, be aware that the stand-offs are properly installed before the mezzanine card is installed.

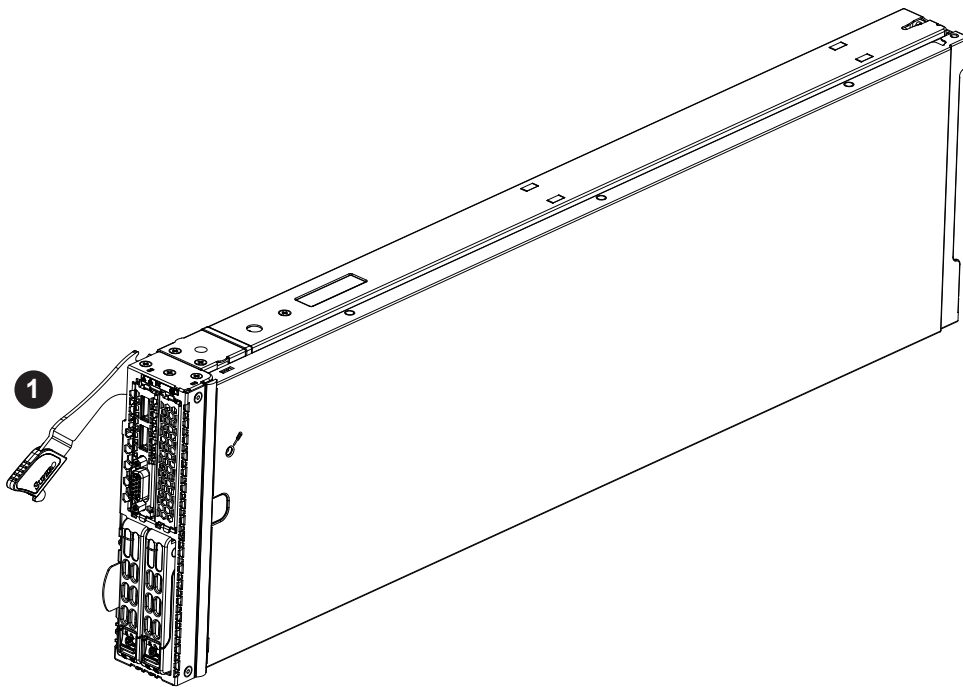

Figure 2-1. Blade Locking Handle

Removing a Blade Unit from the Enclosure

A blade can be removed from the enclosure while other blades continue to operate.

Removing a Blade Unit from the Enclosure

1. Power down the blade unit.
2. Release the handle completely and use it to pull the blade unit from the enclosure.

Removing and Replacing the Blade Cover

The blade cover can be removed to access the mainboard and install processors, memory modules, the onboard battery, etc.

- To remove the cover, remove the screw as illustrated below. Slide the cover toward the rear and lift it off.
- To replace the cover, fit the six studs on the inside of the cover into the slots of the chassis, then slide the cover toward the front of the blade to lock it into place. Replace the locking screw.

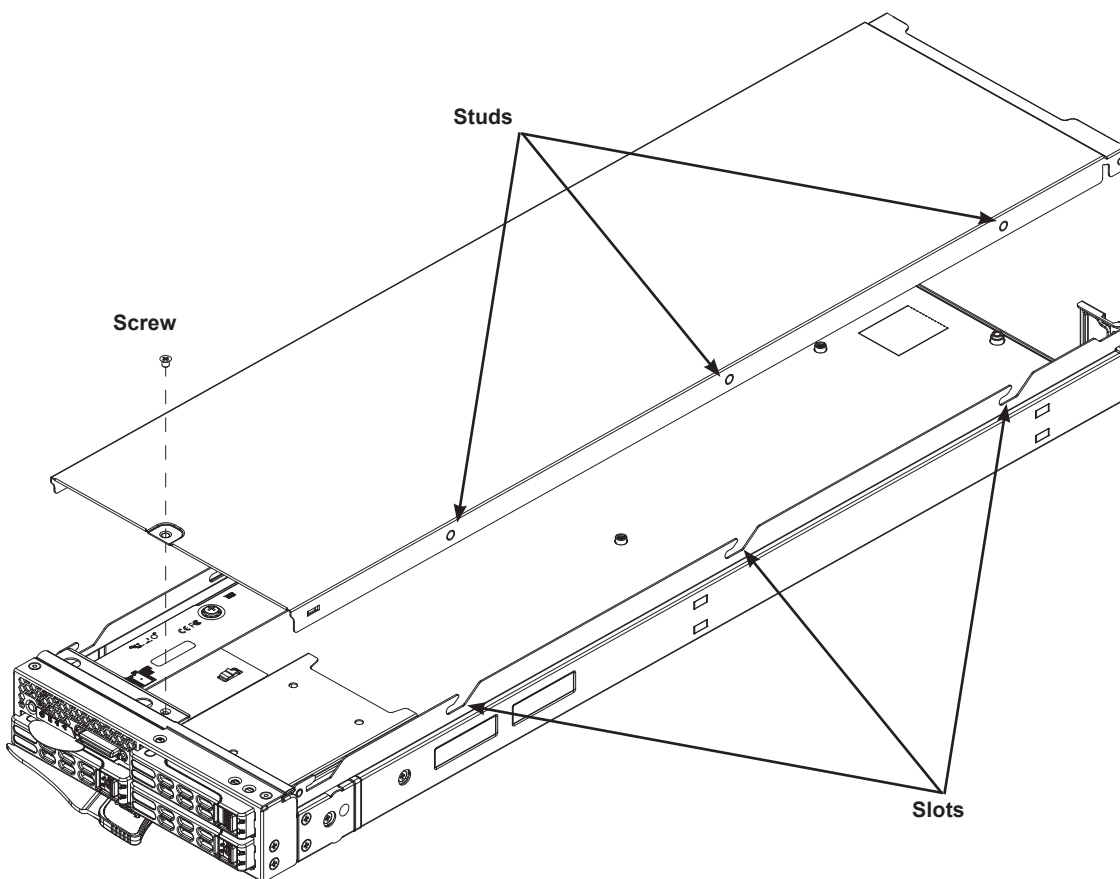

Figure 2-2. Removing the Cover

2.3 Powering Up or Down

Each blade unit may be powered on and off independently from the rest of the blades in the enclosure.

Powering Up a Blade Unit

A blade unit may be powered up in two ways:

- Press the power button on the blade unit.
- Use IPMIView or the browser based management utility to apply power using either a CMM module, or by the use of the onboard BMC chip in the blade module.

Powering Down a Blade Unit

A blade unit may be powered down in any of the following ways:

- Press the power button on the blade unit.
- Use IPMIView or the browser based management utility to power down; requires Operator or Admin privileges on the CMM.
- Use SMCIPMItool when connected to the CMM to power down; requires Operator or Admin privileges on the CMM.
- Use IPMIview or a browser connected to the onboard BMC chip to power down.
- Use SMCIPMItool Command Line Interface (CLI) to the onboard BMC chip; requires Operator or Admin privileges.

2.4 Processor and Heatsink Installation

The processor (CPU) and processor carrier should be assembled together first to form the processor carrier assembly. This will be attached to the heatsink to form the processor heatsink module (PHM) before being installed onto the CPU socket.

Notes:

- Use ESD protection.
- Remove the blade from the enclosure and the blade chassis cover to expose the motherboard.
- Check that the plastic protective cover is on the blade CPU socket and that none of the socket pins are bent. If they are, contact your retailer.
- When handling the processor, avoid touching or placing direct pressure on the land grid array (gold contacts).
- Improper installation or socket misalignment can cause serious damage to the processor or the socket and may require manufacturer repairs.
- Thermal grease is pre-applied on new heatsinks. No additional thermal grease is needed.
- Refer to the Supermicro website for updates on processor support.
- Graphics in this manual are for illustration only. Your components may look different.

The Processor Carrier Assembly

The processor carrier assembly is comprised of the processor and the processor carrier.

1. Hold the processor with the land grid array (LGA, gold contacts) facing down. Locate the gold triangle at the corner of the processor and the corresponding hollowed triangle on the processor carrier as shown below. These triangles indicate the location of pin 1.

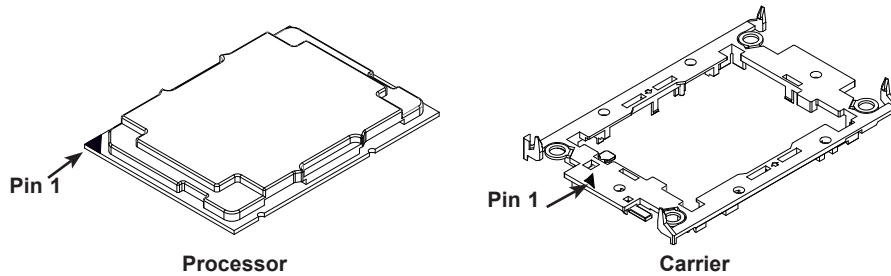

2. Turn the processor over (with the gold LGA up). Locate the CPU keys on the processor and the four latches on the carrier as shown below.

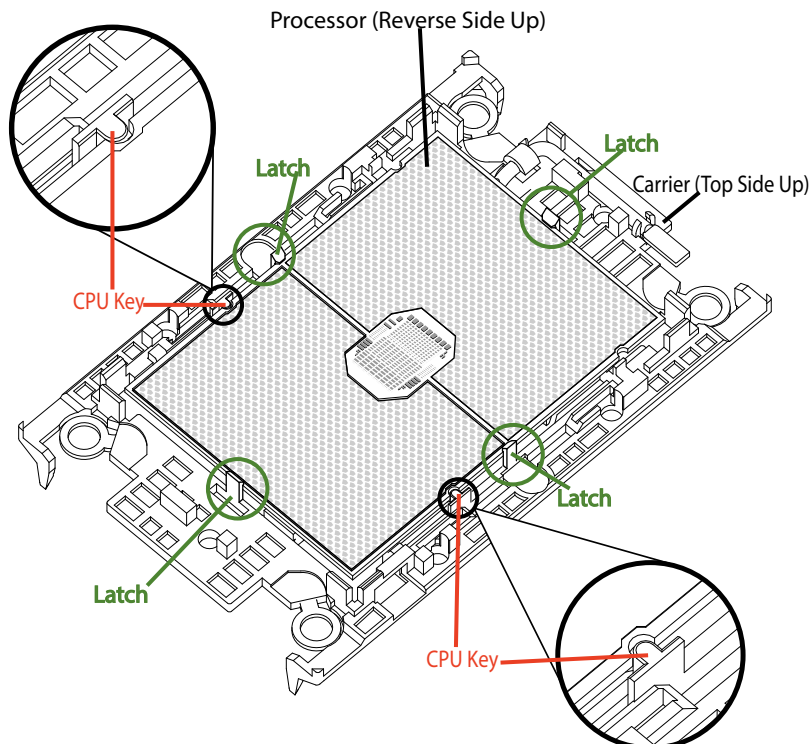

3. Locate the lever on the carrier and, if necessary, press it down as shown below.

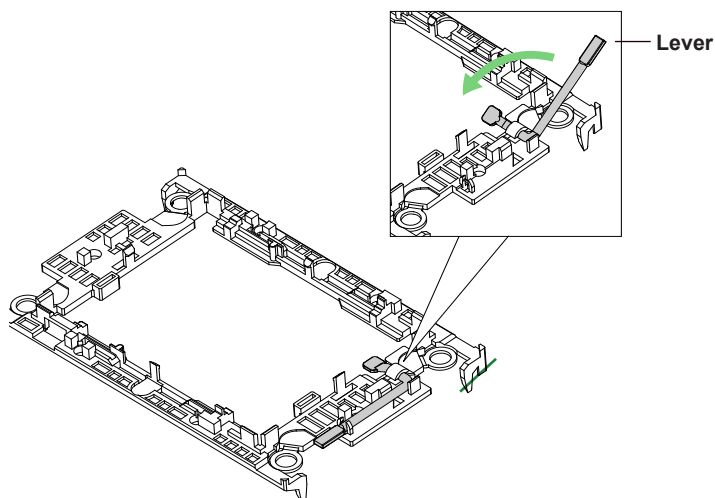

4. Align the CPU keys on the processor (A & B) with those on the carrier (a & b) as shown below.

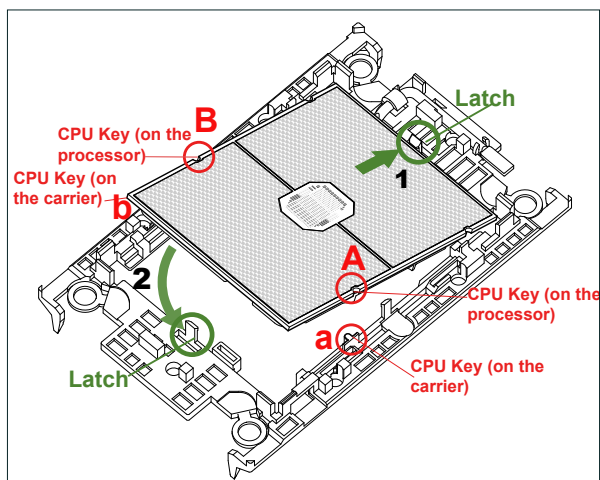

5. Carefully place one end of the processor under latch 1 on the carrier, and then press the other end down until it snaps into latch 2 and is properly seated on the carrier.

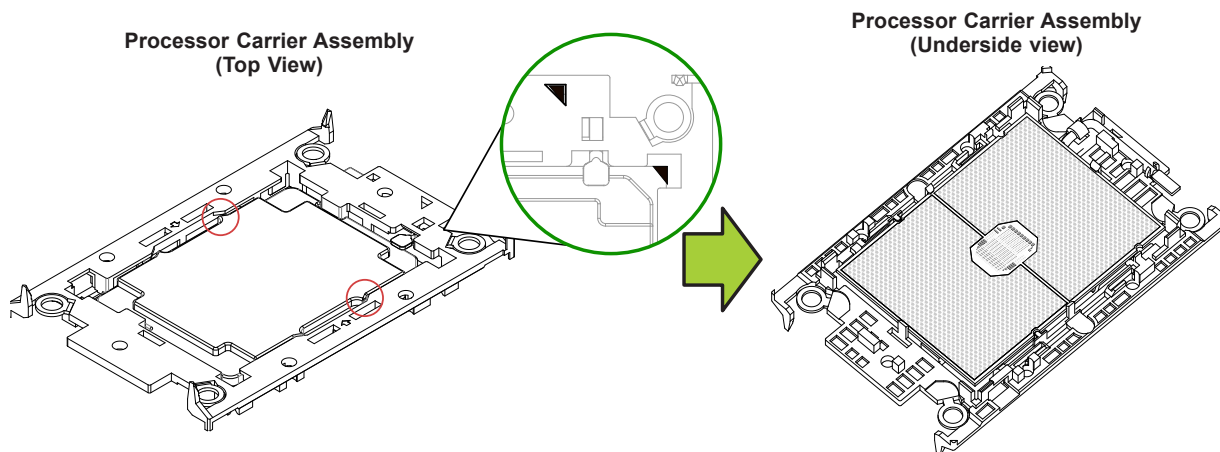

The Processor Heatsink Module (PHM)

After creating the processor carrier assembly, mount the heatsink onto the carrier assembly to form the processor heatsink module (PHM).

Note: If this is a new heatsink, the thermal grease has been pre-applied. Otherwise, apply the proper amount of thermal grease to the underside of the heatsink.

1. Turn the heatsink over with the thermal grease facing up. Note the two triangle cutouts (A, B) located at the diagonal corners of the heatsink as shown in the drawing below.
2. On the processor carrier assembly, find pin 1, as noted by the triangles. Hold the processor carrier assembly over so that the gold LGA is facing up.
3. Align clip "a" (pin 1) on the carrier assembly with the triangular cutout A on the heatsink and b, c, d on the carrier assembly with B, C, D on the heatsink.
4. Push the carrier assembly onto the heatsink, making sure that all four clips on each corner are properly secured.

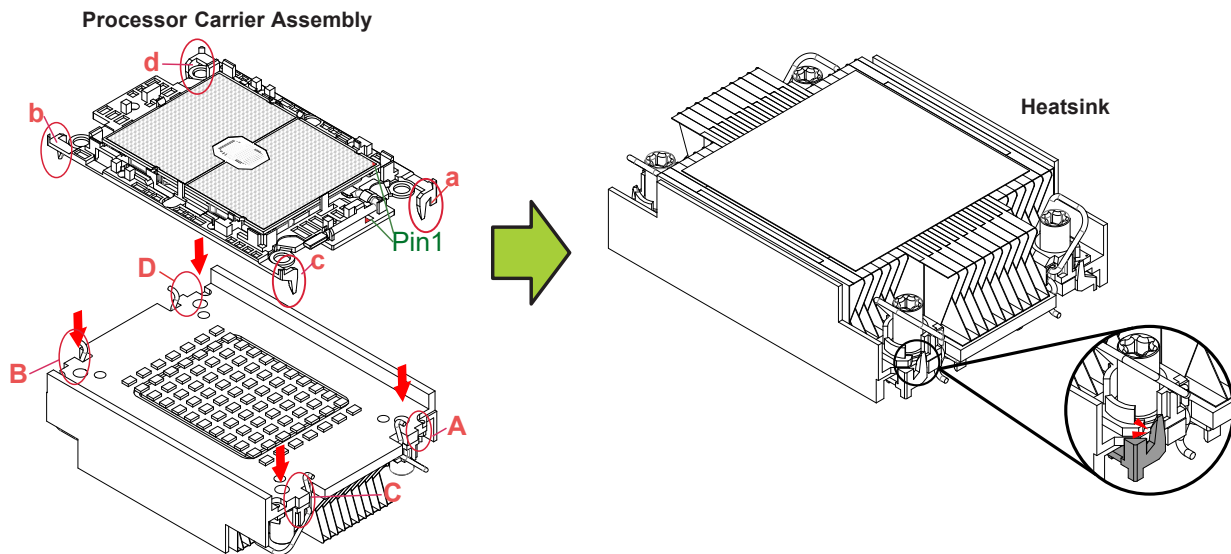

Note: These diagrams show an air cooled heatsink.

Installing the PHM into the CPU Socket

1. Remove the plastic protective cover from the CPU socket. Gently squeeze the grip tabs then pull the cover off.

CPU Socket with Plastic Protective Cover

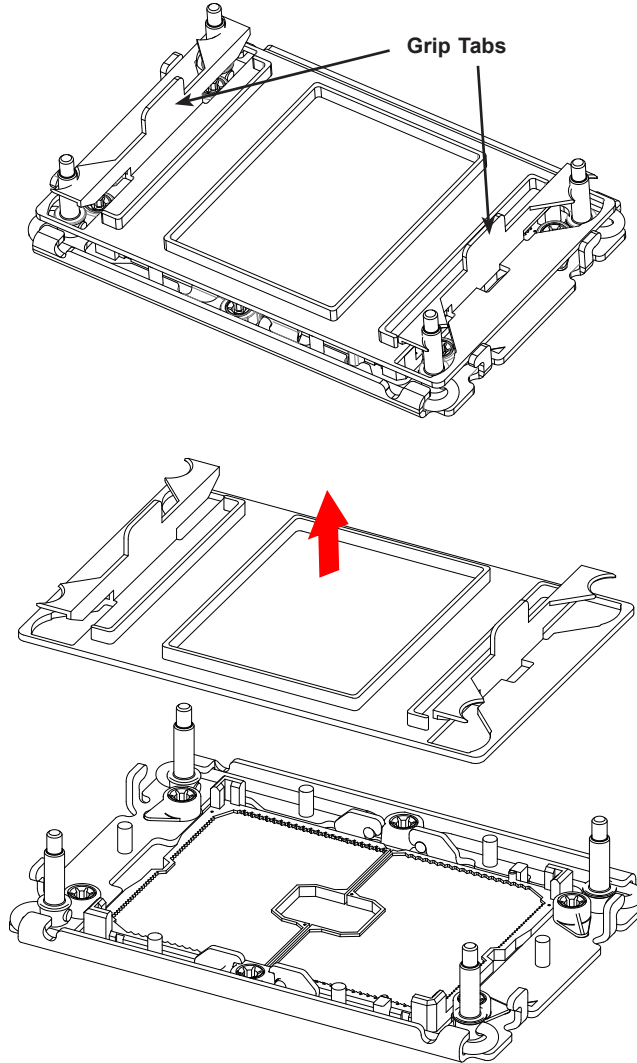

2. Locate four threaded fasteners (a, b, c, d) on the CPU socket.

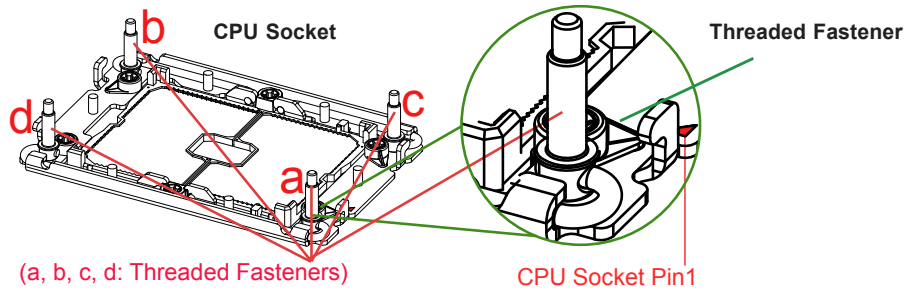

3. Locate four PEEK nuts (A, B, C, D) and four rotating wires (1, 2, 3, 4) on the heatsink as shown below.

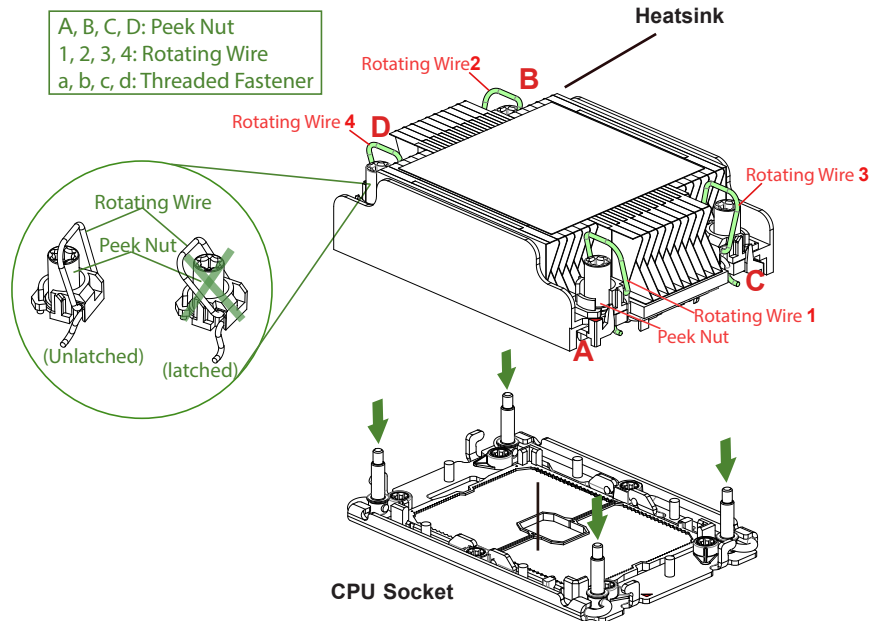

4. Check that the rotating wires (1, 2, 3, 4) are in the unlatched position as shown.

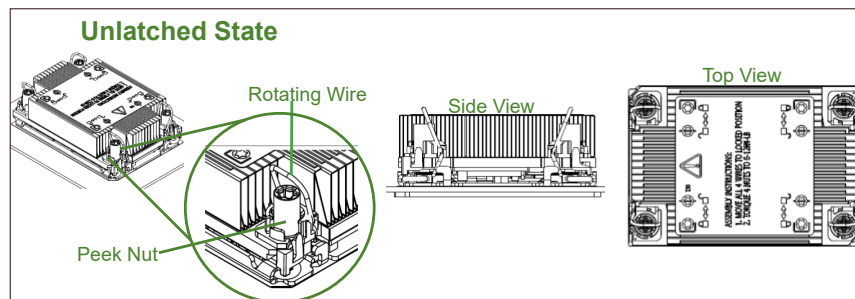

- Align nut A (next to the triangles and pin 1) on the heatsink with threaded fastener "a" on the CPU socket. Also align nuts B, C, D on the heatsink with threaded fasteners b, c, d on the CPU socket.
- Gently place the heatsink on the CPU socket, making sure that each nut is properly aligned with its corresponding threaded fastener.

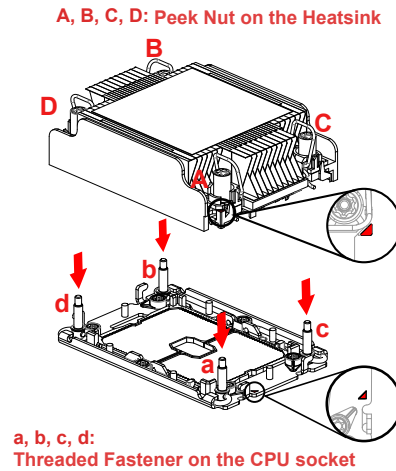

- Press all four rotating wires outward to latch the PHM onto the CPU socket.

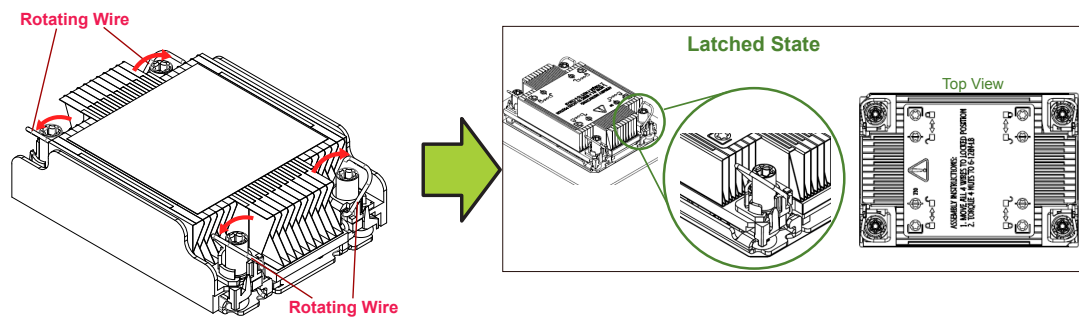

- With a t30-bit screwdriver, tighten all PEEK nuts in the sequence of A, B, C, and D with even pressure not greater than 12 lbf-in.

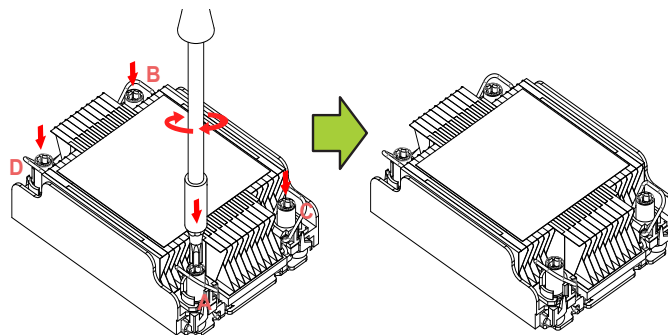

Removing the PHM from the CPU Socket

Be sure the system is shut down and all AC power cords are unplugged.

1. Use a t30-bit screwdriver to loosen the four PEEK nuts on the heatsink in the sequence of A, B, C, and D.

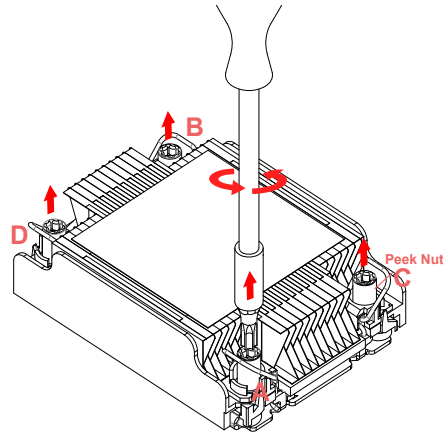

2. Press the four rotating wires inward to unlatch the PHM as shown below.

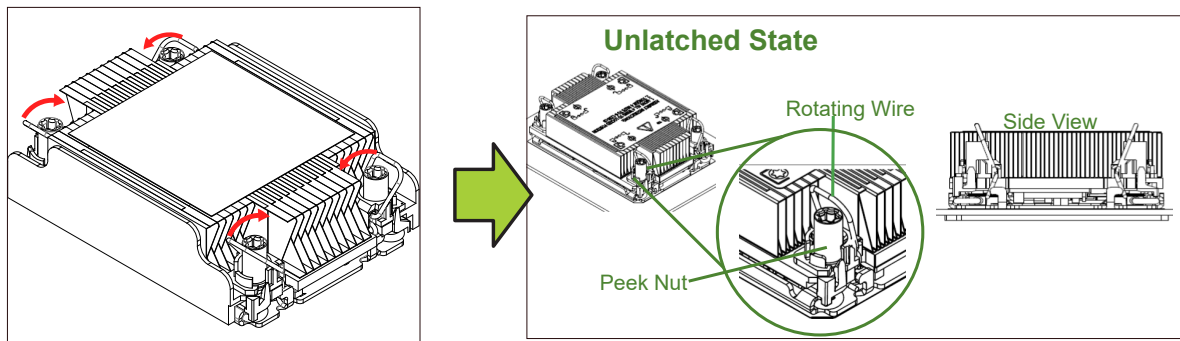

3. Gently lift the PHM upward to remove it from the CPU socket.

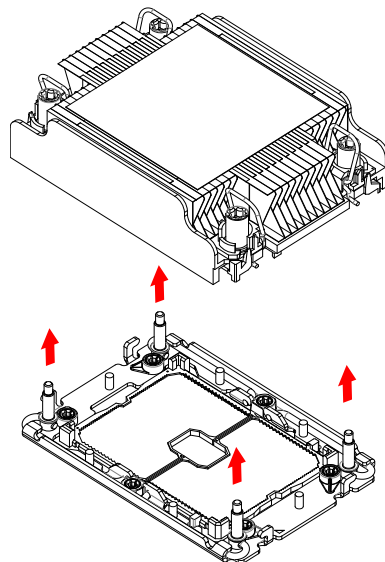

Removing the Processor Carrier Assembly from the PHM

Detach the four plastic clips (a, b, c, d) on the processor carrier assembly from the four corners of the heatsink (A, B, C, D) as shown below, and lift off the processor carrier assembly.

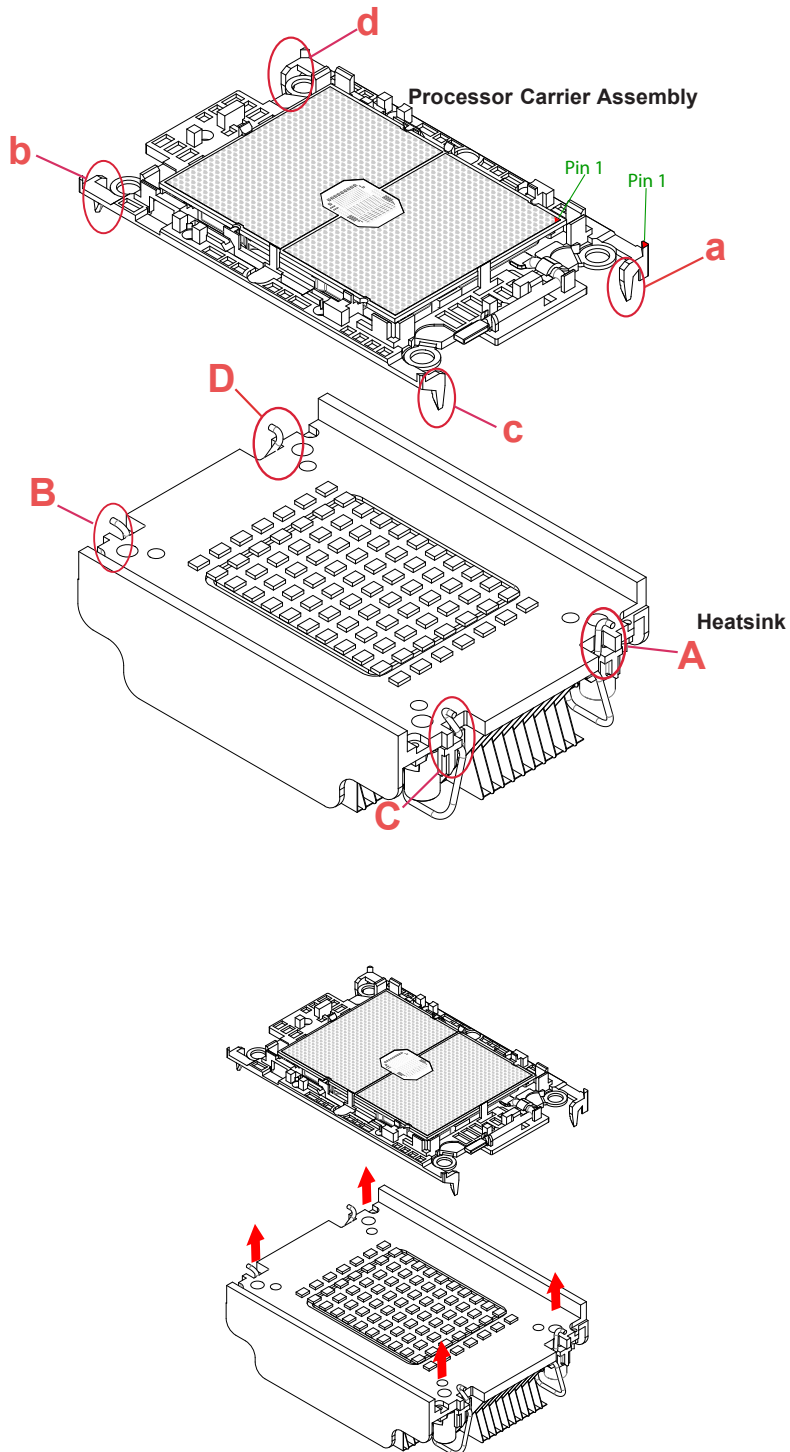

Removing the Processor from the Carrier Assembly

Unlock the lever from its locked position and push it upwards to disengage the processor from the carrier as shown below right. Carefully remove the processor from the carrier.

Processor Carrier Assembly

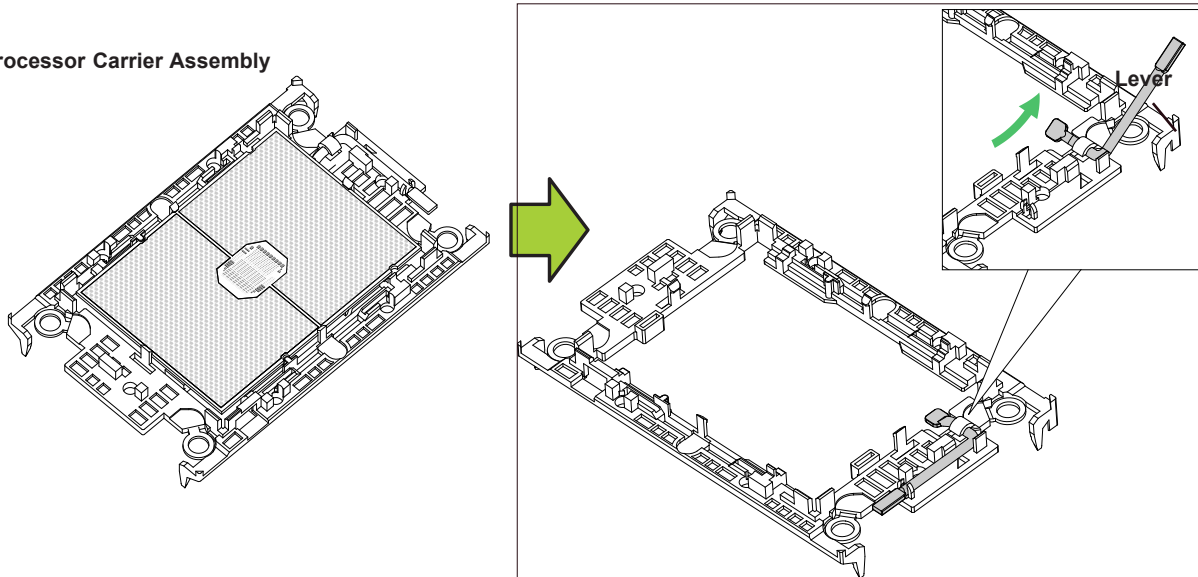

Note: Handle the processor with care to avoid damage.

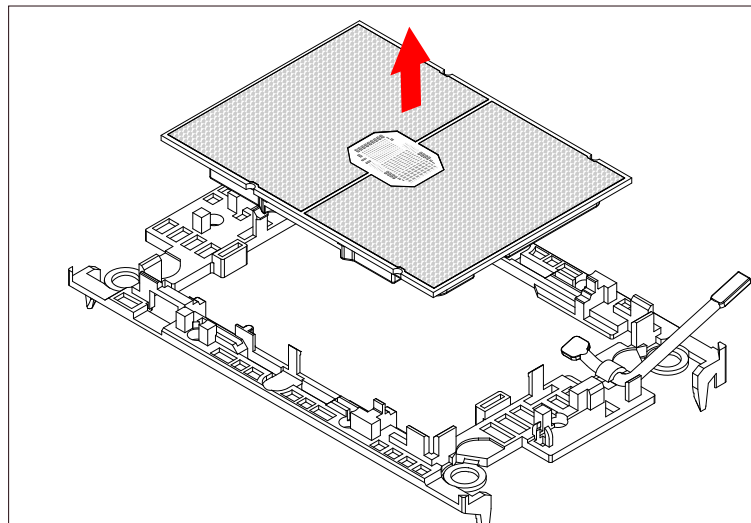

2.5 Memory

Memory Support

The B12DPT-6 has 16 DIMM slots for up to 2TB of 3DS LRDIMM/LRDIMM/3DS RDIMM/RDIMM DDR4 (288-pin) ECC memory with speeds of 3200/2933/2666MT/s. For validated memory, use our [Product Resources page](#).

DDR4 Memory Support for 83xx/63xx/53xx/43xx Processors				
Type	Ranks Per DIMM and Data Width	DIMM Capacity (GB)		Speed (MT/s)
		DRAM Density		One Slot per Channel
		4 Gb	8 Gb	One DIMM per Channel
				1.2 Volts
RDIMM	SRx8	8GB	16GB	3200*
	SRx4	16GB	32GB	
	DRx8	16GB	32GB	
	DRx4	32GB	64GB	
RDIMM 3DS	(4R/8R) x4	2H- 64GB 4H-128GB	2H-128GB 4H-256GB	
LRDIMM	QRx4	64GB	128GB	
LRDIMM 3DS	(4R/8R) x4	4H-128GB	2H-128GB 4H-256GB	

*Only the 83xx and 63xx series support 3200MT/s; for other processors, memory speed as supported by the CPU.

Memory Population Guidelines

- All DIMMs must be DDR4.
- Balance memory. Using unbalanced memory topology, such as populating two DIMMs in one channel while populating one DIMM in another channel, reduces performance. It is not recommended for Supermicro systems.
- In dual-CPU configurations, memory must be installed in the slots associated with the installed CPUs. Also, an odd number of total DIMMs is not recommended.
- For MM, NM/FM ratio is between 1:4 and 1:16. The capacity not used for FM can be used for AD. (NM = Near Memory; FM = Far Memory).

Guidelines Regarding Mixing DIMMs

- Populating slots with a pair of DIMM modules of the same type and capacity results in interleaved memory, which improves memory performance.
- Use memory modules of the same type and speed, as mixing is not allowed.
- x4 and x8 DIMMs can be mixed in the same channel.
- Mixing of LRDIMMs and RDIMMs is not allowed in the same channel, across different channels, and across different sockets.
- Mixing of non-3DS and 3DS LRDIMM is not allowed in the same channel, across different channels, and across different sockets.

DIMM Construction

- RDIMM (*non-3DS*) Raw Cards: A/B (2Rx4), C (1Rx4), D (1Rx8), E (2Rx8)
- 3DS RDIMM Raw Cards: A/B (4Rx4)
- LRDIMM (*non-3DS*) Raw Cards: D/E (4Rx4)
- 3DS LRDIMM Raw Cards: A/B (8Rx4)

Memory Population Sequence

Blue slots versus black slots: Install the first DIMM in the blue memory slot, which is the first of a memory channel.

The following memory population sequence table was created based on guidelines provided by Intel to support Supermicro motherboards.

Memory Population for the X12 DP Motherboard, 16 DIMM Slots	
CPU/DIMMs	Memory Slots
1 CPU & 1 DIMM*	A1
1 CPU & 2 DIMMs	A1, E1
1 CPU & 4 DIMMs	A1, C1, E1, G1
1 CPU & 6 DIMMs*	A1, B1, C1, E1, F1, G1
1 CPU & 8 DIMMs	A1, B1, C1, D1, E1, F1, G1, H1
2 CPUs & 2 DIMMs	CPU1: A1 CPU2: A1
2 CPUs & 4 DIMMs	CPU1: A1, E1 CPU2: A1, E1
2 CPUs & 6 DIMMs*	CPU1: A1, C1, E1, G1 CPU2: A1, E1
2 CPUs & 8 DIMMs	CPU1: A1, C1, E1, G1 CPU2: A1, C1, E1, G1
2 CPUs & 10 DIMMs*	CPU1: A1, B1, C1, E1, F1, G1 CPU2: A1, C1, E1, G1
2 CPUs & 12 DIMMs	CPU1: A1, B1, C1, E1, F1, G1 CPU2: A1, B1, C1, E1, F1, G1
2 CPUs & 14 DIMMs*	CPU1: A1, B1, C1, D1, E1, F1, G1, H1 CPU2: A1, B1, C1, E1, F1, G1
2 CPUs & 16 DIMMs	CPU1: A1, B1, C1, D1, E1, F1, G1, H1 CPU2: A1, B1, C1, D1, E1, F1, G1, H1

*Unbalanced, not recommended.

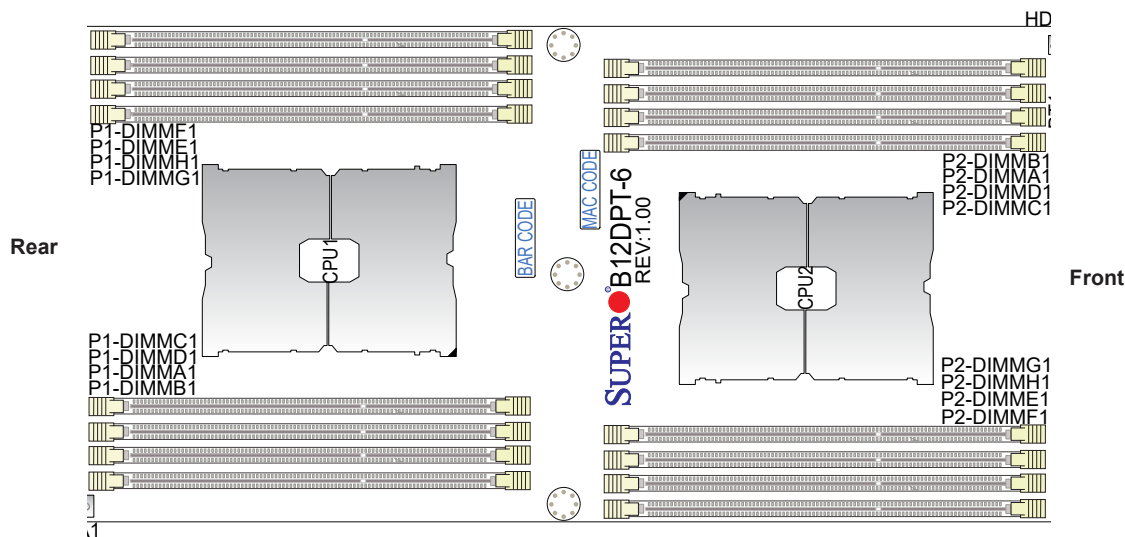

Figure 2-3. Memory Slots

Installing Memory

ESD Precautions

Electrostatic Discharge (ESD) can damage electronic components including memory modules. To avoid damaging DIMM modules, it is important to handle them carefully. The following measures are generally sufficient.

- Use a grounded wrist strap designed to prevent static discharge.
- Handle the memory module by its edges only.
- Put the memory modules into the antistatic bags when not in use.

Installing Memory

Begin by removing power from the system as described in Section 3.1. Follow the memory population sequence in the table above.

1. Push the release tabs outwards on both ends of the DIMM slot to unlock it.

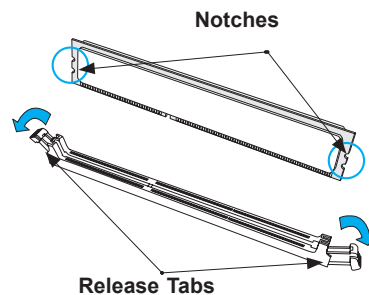

2. Align the key of the DIMM with the receptive notch on the memory slot and with your thumbs on both ends of the module, press it straight down into the slot until the module snaps into place.

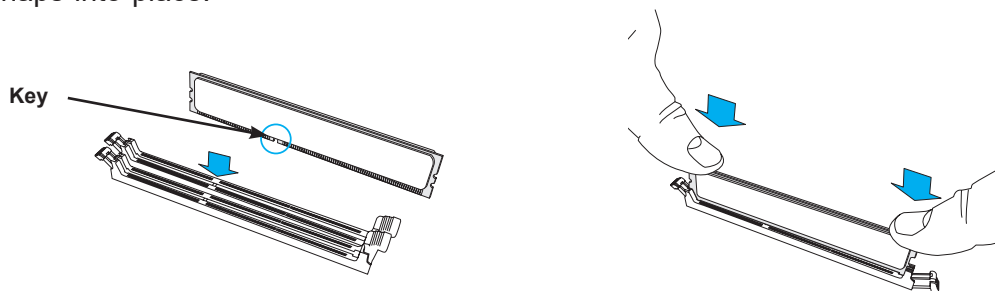

3. Press the release tabs to the locked position to secure the DIMM module into the slot.

Caution: Exercise extreme caution when installing or removing memory modules to prevent damage to the DIMMs or slots.

Removing Memory

To remove a DIMM, unlock the release tabs then pull the DIMM from the memory slot.

2.6 Storage Drives

The blade has two or three 2.5" hot-swap storage drive bays. The drives are mounted in drive carriers that simplify their removal from the chassis. These carriers also help promote proper airflow. Even carriers without drives must remain in the chassis for proper airflow.

The blade can be purchased with drives installed or without drives installed.

For VROC configurations, refer to the VROC appendix in this manual.

Note: Enterprise level storage drives are recommended for use in Supermicro systems. For information on recommended drives, visit the Supermicro website.

Drive Carrier Indicators

Each drive carrier has two LED indicators: an activity indicator and a status indicator. For RAID configurations using a controller, the meaning of the status indicator is described in the table below. For OS RAID or non-RAID configurations, some LED indications are not supported, such as hot spare.

Drive Carrier LED Indicators			
	Color	Blinking Pattern	Behavior for Device
Activity LED	Blue	Solid On	SAS/NVMe drive installed
	Blue	Blinking	I/O activity
Status LED	Red	Solid On	Failure of drive with RSTe support
	Red	Blinking at 1 Hz	Rebuilding drive with RSTe support
	Red	Blinking with two blinks and one stop at 1 Hz	Hot spare for drive with RSTe support <i>(not supported in VMD mode)</i>
	Red	On for five seconds, then off	Power on for drive with RSTe support
	Red	Blinking at 4 Hz	Identify drive with RSTe support
	Green	Solid On	Safe to remove NVMe device <i>(not supported in VMD mode)</i>
	Amber	Blinking at 1 Hz	Attention state—do not remove NVMe device <i>(not supported in VMD mode)</i>

Removing a Hot-Swap Drive Carrier from the Chassis

1. Press the release button (shown below as **1**) on the drive carrier, which will extend the drive carrier handle.
2. Use the drive carrier handle to pull the drive out of the chassis.

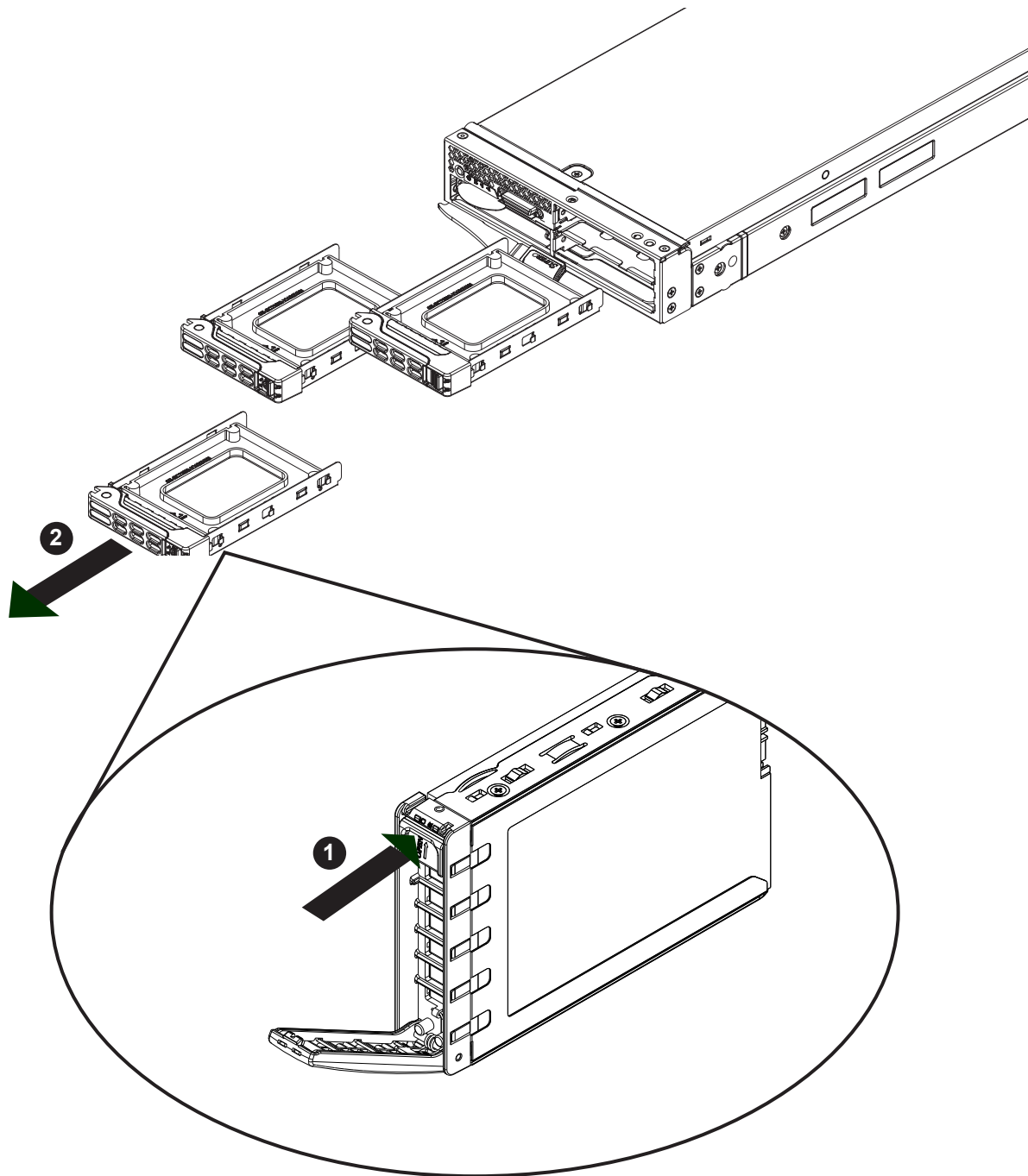

Figure 2-4. Removing a Drive Carrier

Installing a Drive

1. Remove the dummy drive, which comes pre-installed in the drive carrier. Pull out the two locking clasps on the left outside of the carrier and lift out the dummy drive.
2. Position the drive above the carrier with the PCB side facing down and the connector end toward the rear of the carrier.

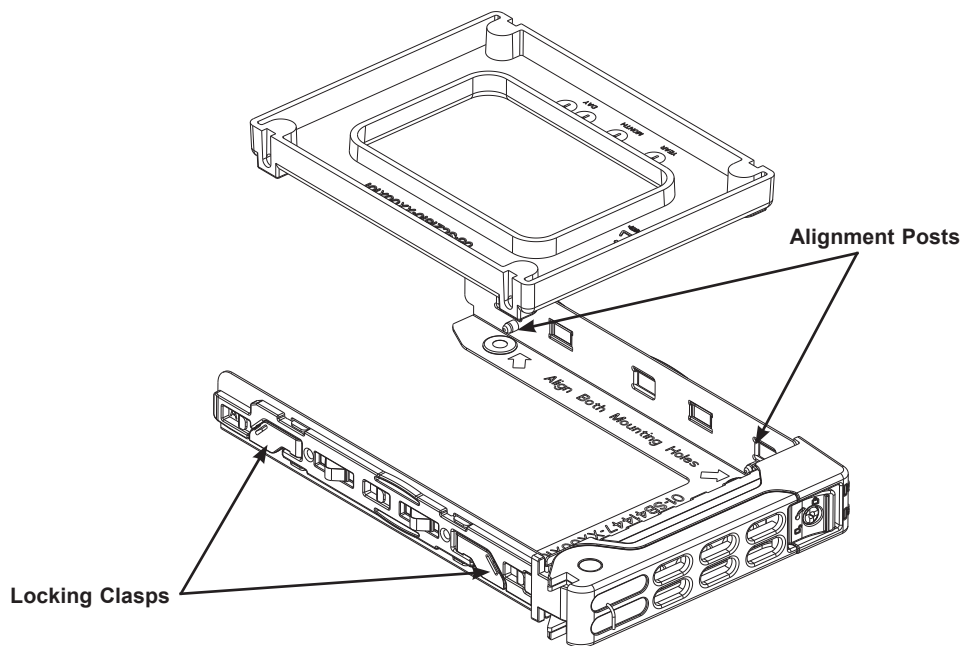

Figure 2-5. Removing the Dummy Drive from a Carrier

3. Tilt the drive to insert it onto the two posts on the right inside of the carrier.
4. Pull out the two spring locking clasps and allow the drive to sit fully in the carrier, then close them to secure the drive.
5. Insert the drive carrier into its bay, keeping the release button on the right. When the carrier reaches the rear of the bay, the release handle will retract.
6. Push the handle in until it clicks into its locked position

Hot-Swap for NVMe Drives

Supermicro servers support NVMe surprise hot-swap. For even better data security, NVMe *orderly* hot-swap is recommended. NVMe drives can be ejected and replaced remotely using IPMI.

Note: If you are using VROC, see the VROC appendix in this manual instead.

Ejecting a Drive

1. IPMI > Server Health > NVMe SSD

2. Select Device, Group and Slot, and click **Eject**. After ejecting, the drive Status LED indicator turns green.
3. Remove the drive.

Note that *Device* and *Group* are categorized by the CPLD design architecture.

Slot is the slot number on which the NVMe drives are mounted.

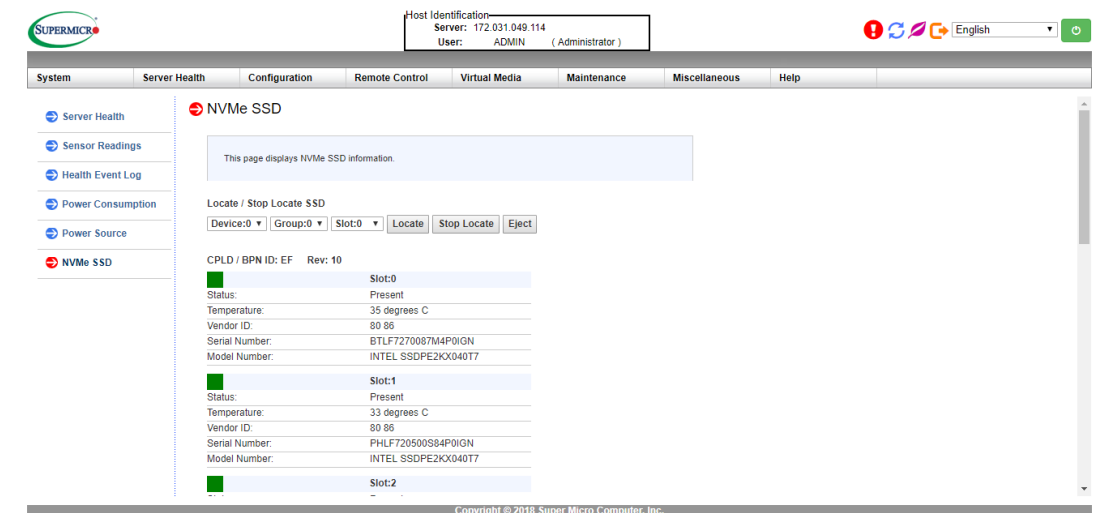

Figure 2-6. IPMI Screenshot

Replacing the Drive

1. Remove the old drive and insert the replacement drive.
2. IPMI > Server Health > NVMe SSD
3. Select Device, Group and slot and click **Insert**. The drive Status LED indicator flashes red, then turns off. The Activity LED turns blue.

Checking the Temperature of an NVMe Drive

There are two ways to check using IPMI.

Checking a Drive

- **IPMI > Server Health > NVMe SSD** – Shows the temperatures of all NVMe drives, as in Figure 2-6.
- **IPMI > Server Health > Sensor Reading > NVME_SSD** – Shows the single highest temperature among all the NVMe drives.

M.2 Solid State Drives

One option for the mezzanine card supports M.2 solid state drives (SSDs) of 80mm in length. There is an hole in the motherboard standoff for a plastic clasp.

Installing an M.2 SSD

Caution: Use industry-standard anti-static equipment, such as gloves or wrist strap, and follow precautions to avoid damage caused by ESD.

1. Insert the SSD into the socket on the motherboard. Then push it flat against the standoff.
2. Secure the SSD by firmly inserting the plastic plug into the standoff.

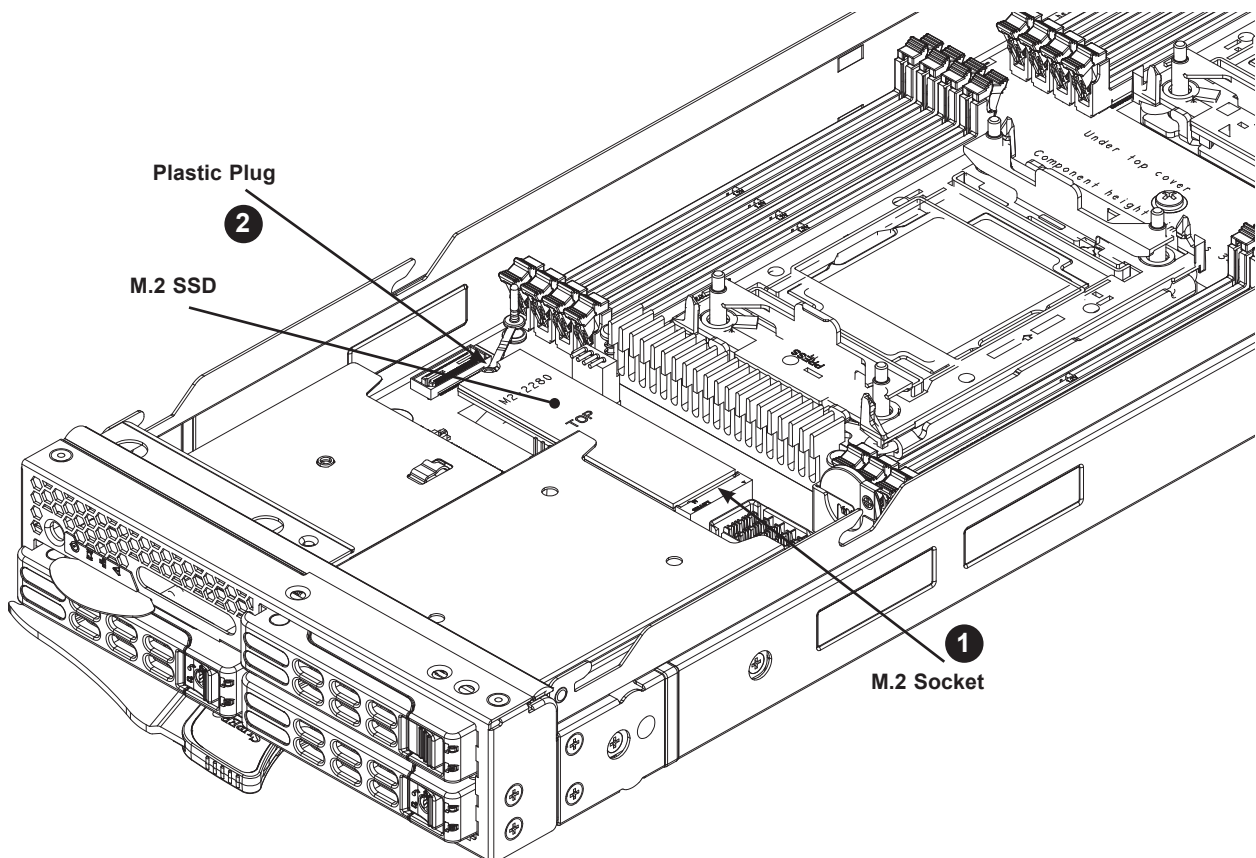

Figure 2-7. Installing M.2 SSD

2.7 Installing the Operating System

An operating system (OS) must be installed on each blade module. Blades with Microsoft Windows OS and blades with Linux OS can both occupy and operate within the same blade enclosure. Refer to the SuperMicro web site for a complete list of supported operating systems. There are several methods of installing an OS to the blade modules.

Installing with an External USB CD-ROM Drive

Note: Installing the OS from an external CD-ROM drive may take several hours to complete.

1. Connect an SUV cable (Serial port/USB port/Video port cable) to the KVM connector on the front of the blade module. You will then need to attach a USB hub to the USB port on this cable to provide multiple USB ports.
2. Connect the external CD-ROM drive, a USB keyboard and a mouse to the USB hub. You will also need to connect a monitor to the video connector on the SUV cable. Turn on the blade module.
3. Insert the CD containing the OS into the CD-ROM drive.
4. Follow the prompts to begin the installation.

Installing by using PXE Boot (common method)

Preboot Execution Environment (PXE) is used to boot a computer over a network. To install the OS via PXE, the following conditions must be met:

- The PXE BOOT option in BIOS must be enabled.
- A PXE server has been configured (this can be another blade in the system).
- The PXE server must be connected over a network to the blade to be booted.
- The blade has only non-partitioned, unformatted hard drives installed and no bootable devices attached to it.

Once these conditions are met, make sure the PXE server is running. Then turn on the blade on which you wish to boot or install the OS. The BIOS in the blade will look at all bootable devices and finding none, will connect to the PXE server to begin the boot/install.

Installing by using Virtual Media (Drive Redirection)

You can install the OS via Virtual Media through either the IPMIview (Java based client utility), SuperBladeTool or the Web-based Management Utility. With this method, the OS is installed from an ISO image that resides on another system/blade.

Refer to the manuals on your SuperBlade CD-ROM for further details on the Virtual Media (CD-ROM or Drive Redirection) sections of these two utility programs.

Linux Installation with Two Storage Drives

When installing Linux with two storage drives on the you may encounter a situation where one drive is recognized as HDA and the other drive is recognized as SDA. This is normal since in this case the connection for SATA HDDs is from two different controllers.

So under Native IDE mode (which is the default), your Linux OS will see one drive as HDA and the other as SDA. If the SATA controller mode operation is changed to AMD_AHCI in the BIOS, then the HDDs will appear as SDA and SDB.

2.8 Configuring and Setting up RAID

For RAID setup, see <http://www.supermicro.com/support/manuals/> under RAID Installation Guides.

2.9 Driver Installation

The Supermicro website contains drivers and utilities for your system at <https://www.supermicro.com/wftp/driver>. Some of these must be installed, such as the chipset driver.

After accessing the website, go into the CDR_Images (in the parent directory of the above link) and locate the ISO file for your motherboard. Download this file to a USB flash drive or a DVD. (You may also use a utility to extract the ISO file if preferred.)

Another option is to go to the Supermicro website at <http://www.supermicro.com/products/>. Find the product page for your motherboard, and "Download the Latest Drivers and Utilities".

Insert the flash drive or disk and the screenshot shown below should appear.

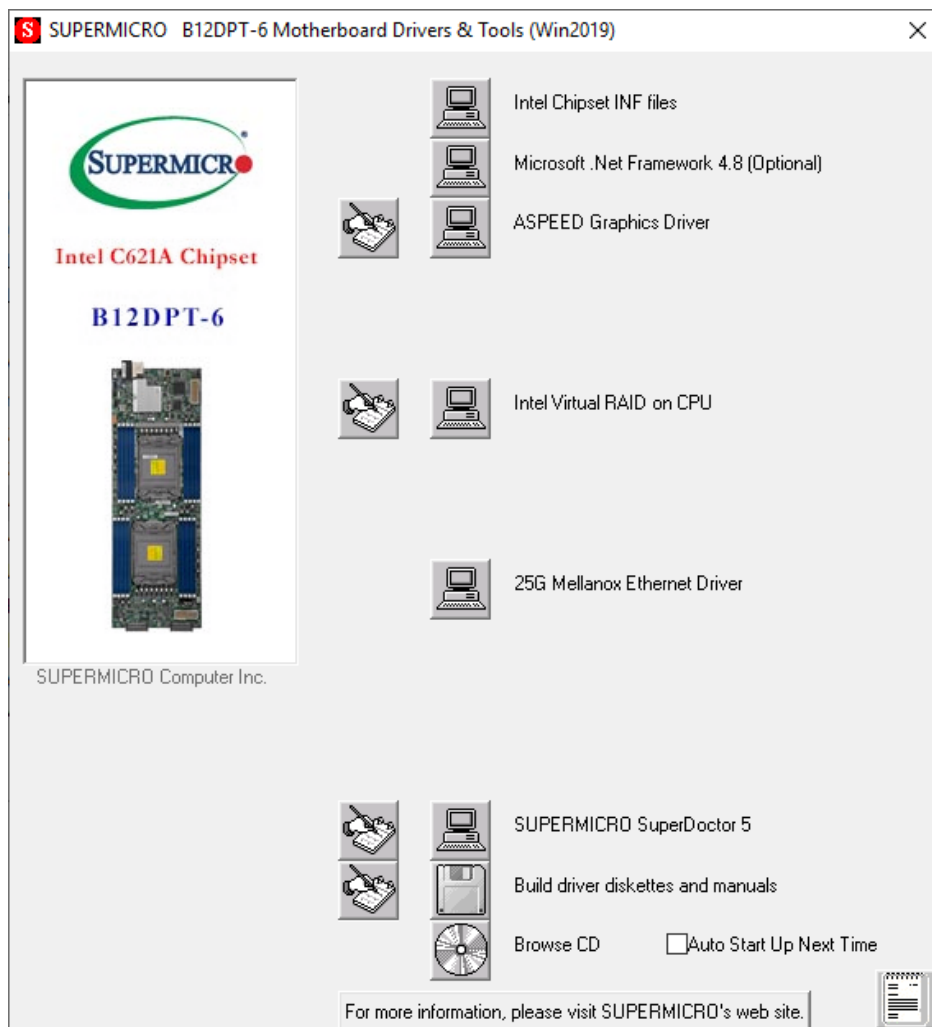

Figure 2-8. Driver & Tool Installation Screen

Note: Click the icons showing a hand writing on paper to view the readme files for each item. Click the computer icons to the right of these items to install each item (from top to the bottom) one at a time. **After installing each item, you must re-boot the system before moving on to the next item on the list.** The bottom icon with a CD on it allows you to view the entire contents.

Chapter 3

Management and Maintenance

This chapter provides instructions for managing the blade unit and performing maintenance on components.

3.1 Management Software

System management may be performed with any of three software packages: IPMIview, IPMItool or a Web-based Management Utility. These are designed to provide an administrator with a comprehensive set of functions and monitored data to keep tabs on the system and perform management activities.

BMC

The motherboard provides remote access, monitoring and management through the baseboard management controller (BMC) and other management controllers distributed among different system modules. There are several BIOS settings that are related to BMC. For general documentation and information on BMC, visit our website at:

www.supermicro.com/en/solutions/management-software/bmc-resources

BMC ADMIN User Password

For security, each system is assigned a unique default BMC password for the ADMIN user. This can be found on a sticker on the chassis, as noted in Section 1.4, and a sticker on the motherboard. The sticker also displays the BMC MAC address. For more information, refer to: https://www.supermicro.com/en/support/BMC_Unique_Password.



Figure 3-1. BMC Password Label

3.2 Motherboard Battery

The motherboard uses non-volatile memory to retain system information when system power is removed. This memory is powered by a lithium battery residing on the motherboard.

Replacing the Battery

Begin by removing power from the system as described in section 3.1.

1. Push aside the small clamp that covers the edge of the battery. When the battery is released, lift it out of the holder.
2. To insert a new battery, slide one edge under the lip of the holder with the positive (+) side facing up. Then push the other side down until the clamp snaps over it.

Note: Handle used batteries carefully. Do not damage the battery in any way; a damaged battery may release hazardous materials into the environment. Do not discard a used battery in the garbage or a public landfill. Please comply with the regulations set up by your local hazardous waste management agency to dispose of your used battery properly.

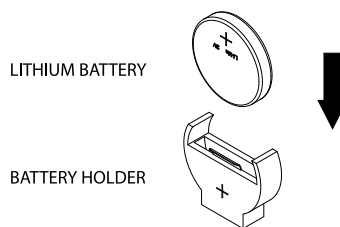

Figure 3-2. Installing the Onboard Battery

Warning: There is a danger of explosion if the onboard battery is installed upside down (which reverses its polarities). This battery must be replaced only with the same or an equivalent type recommended by the manufacturer (CR2032).

3.3 System Cooling

Installing the Air Shrouds

Air shrouds concentrate airflow to maximize fan efficiency.

Installing the Standard Air Shrouds

- Position the air shrouds as illustrated in the figure below, sliding them over the components, and secure them with screws. The *screws are shared* with the motherboard.

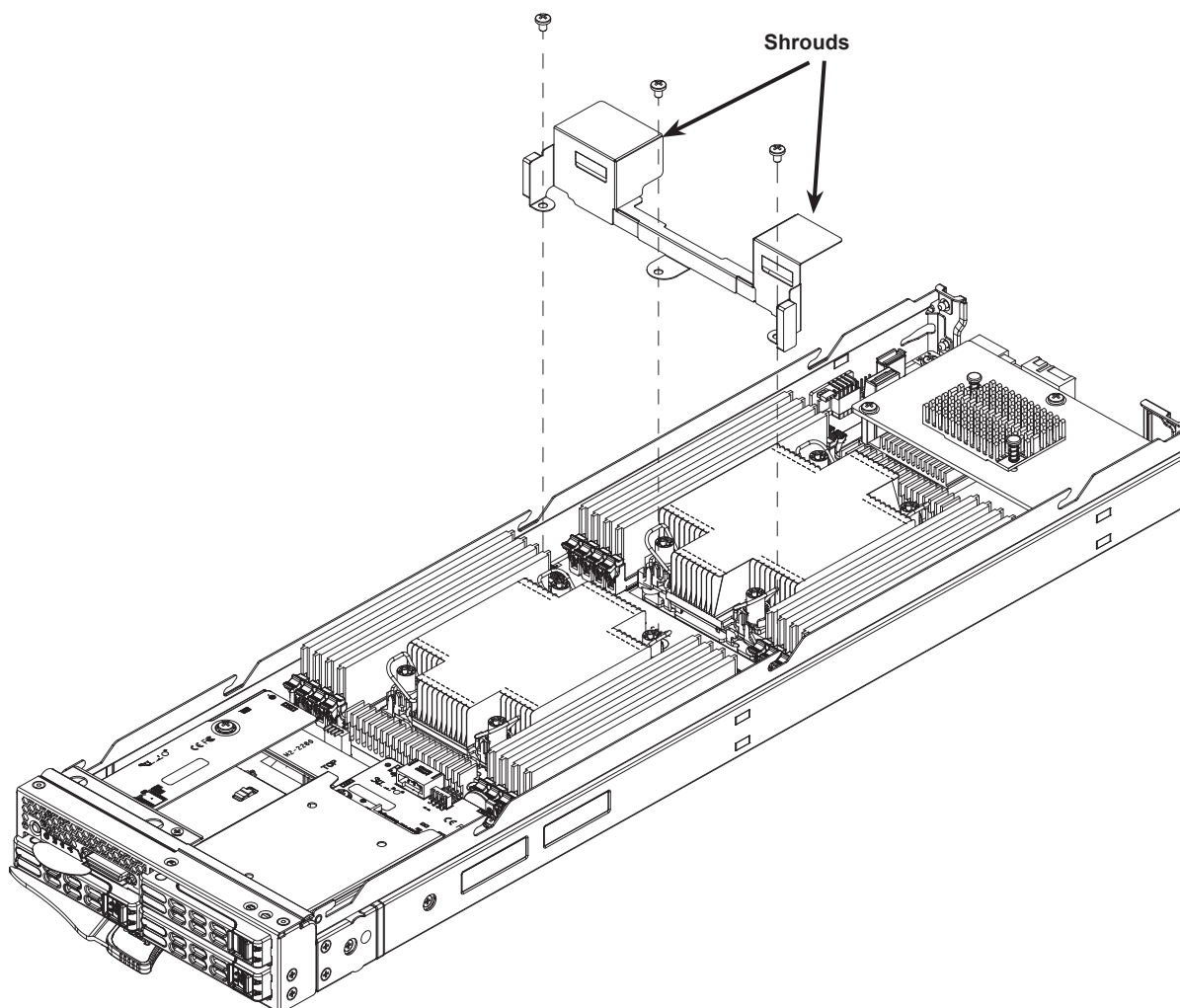

Figure 3-3. Installing the Standard Air Shrouds

Checking the Server Air Flow

- Make sure there are no objects to obstruct airflow through the server.
- Do not operate the server without drive carriers in the drive bays.
- Use only Supermicro recommended server parts.
- Make sure no wires or foreign objects obstruct air flow through the chassis. Pull all excess cabling out of the airflow path or use shorter cables.

The control panel LEDs display system heat status. See “Control Panel” in Chapter 1 for details.

Overheating

There are several possible responses if the system overheats.

- Use the LEDs to determine the nature of the overheating condition.
- Confirm that the chassis covers are installed properly.
- Make sure all fans are present and operating normally.
- Check the routing of the cables.
- Verify that the heatsinks are installed properly.

3.4 CMOS Clear

JBT1 is used to clear CMOS (see motherboard drawing, Chapter 4). Instead of pins, this jumper consists of contact pads to prevent accidentally clearing the contents of CMOS.

To Clear CMOS

1. First power down the system and unplug the power cord(s).
2. Remove the cover of the chassis to access the motherboard.
3. Remove the onboard battery from the motherboard.
4. Short the CMOS pads with a metal object such as a small screwdriver for at least four seconds.
5. Remove the screwdriver (or shorting device).
6. Replace the cover, reconnect the power cord(s) and power on the system.



JBT1 contact pads

Notes: Clearing CMOS will also clear all passwords.

Do not use the PW_ON connector to clear CMOS.

3.5 Where to Get Replacement Components

If you need replacement parts for your system, to ensure the highest level of professional service and technical support, purchase exclusively from our Supermicro Authorized Distributors/System Integrators/Resellers. A list can be found at: <http://www.supermicro.com>. Click the menu icon > **Buy** > **Where to Buy** link.

3.6 Returning Merchandise for Service

A receipt or copy of your invoice marked with the date of purchase is required before any warranty service will be rendered. You can obtain service by calling your vendor for a Returned Merchandise Authorization (RMA) number. When returning to the manufacturer, the RMA number should be prominently displayed on the outside of the shipping carton, and mailed prepaid or hand-carried. Shipping and handling charges will be applied for all orders that must be mailed when service is complete.

For faster service, RMA authorizations may be requested online (<http://www.supermicro.com/support/rma/>).

Whenever possible, repack the chassis in the original Supermicro carton, using the original packaging material. If these are no longer available, be sure to pack the chassis securely, using packaging material to surround the chassis so that it does not shift within the carton and become damaged during shipping.

This warranty only covers normal consumer use and does not cover damages incurred in shipping or from failure due to the alteration, misuse, abuse or improper maintenance of products.

During the warranty period, contact your distributor first for any product problems.

Chapter 4

Motherboard Connections

This chapter describes the jumpers, connections and LEDs on the motherboard and provides pinout definitions. Some connections might not be used in this system.

4.1 Motherboard Layout

Below is a layout of the B12DPT-6 with descriptions on the following page.

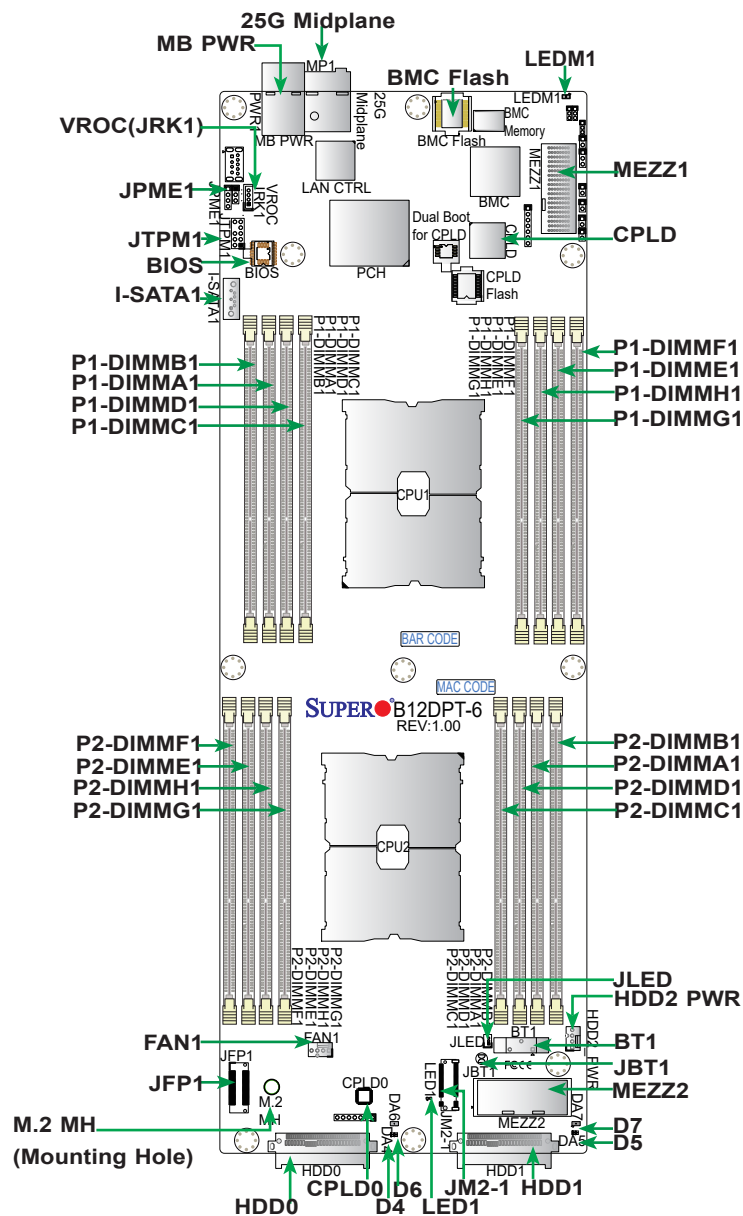

Figure 4-1. Motherboard Layout

Quick Reference

Jumper	Description	Default Setting
JBT1	CMOS Clear	Open (Normal)
JPME1	ME Manufacturing Recovery	Pins 1-2 (Normal)

Connector	Description
BT1	Onboard CMOS battery
CPLD0	Complex Programmable Logic Device (CPLD) chip
FAN1	Cooling fan header reserved for liquid cooling
HDD0/HDD1	Front accessible Hard Driver Connector #0/Hard Driver Connector #1
HDD2_PWR	Power connector for HDD 2
JBT1	Contacts for CMOS Clear
JFP1	Front Panel Control board with KVM & USB 2.0 support (via Cable CBL-0218L)
JLED	HDD2 SATA Activity LED
JM2-1 & M.2 MH	M.2 slot (PCIe 4.0 x4) and M.2 Mounting Hole (M.2 MH)
JTPM1	Trusted Platform Module/Port 80 connector
MEZZ1/MEZZ2	PCI Mezzanine Card Connector 1/Mezzanine Card Connector 2
MP1	Onboard 25G midplane
PWR1	Motherboard Power connector
I-SATA 1	Intel PCH SATA 3.0 port (with RAID 0, 1, 5, 10)
VROC (JRK1)	Intel VROC key header for NVMe RAID support

LED	Description	State: Status
DA4	HDD0 Heartbeat LED	Green: HDD0 Normal; Red: HDD0 Failure
DA5	HDD1 Heartbeat LED	Green: HDD1 Normal; Red: HDD1 Failure
DA6	HDD0 Activity LED	Blue: HDD0 Active
DA7	HDD1 Activity LED	Blue: HDD0 Active
LED1	M.2 Activity LED	Green: M.2 Normal
LEDM1	BMC Activity LED	Green: BMC Normal

Motherboard Block Diagram

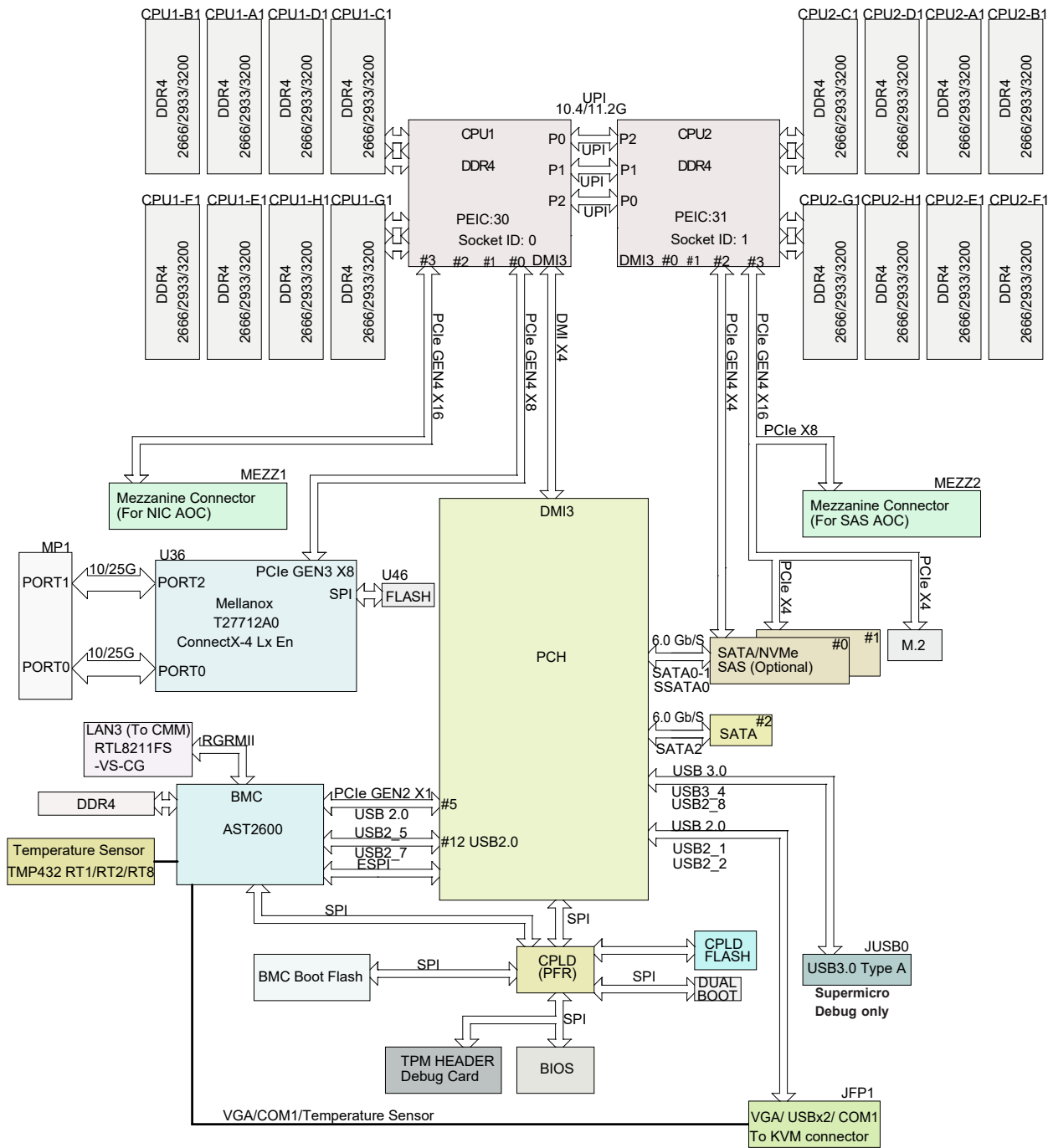

Figure 1-7. Motherboard Block Diagram

4.2 Power Connections

Main Power Connector

The proprietary main power header is PWR1.

Storage Drive Power Connectors

The proprietary 4-pin connector, HDD2_PWR, is connected to the AOM-SB1-SATA31 to provide power to the HDD2.

4.3 Headers and Connectors

Fan Header

A 4-pin fan header (FAN1) is located on the motherboard. This fan header is reserved for liquid cooling.

Fan Header Pin Definitions	
Pin#	Definition
1	Ground (Black)
2	+12V (Red)
3	Tachometer
4	PWM Control

TPM Header

The JTPM1 header is used to connect a Trusted Platform Module (TPM)/Port 80, which is available from Supermicro. A TPM/Port 80 connector is a security device that supports encryption and authentication in hard drives. It allows the motherboard to deny access if the TPM associated with the storage drive is not installed in the system.

Trusted Platform Module/Port 80 Header Pin Definitions			
Pin#	Definition	Pin#	Definition
1	P3V3	2	SPI_TPM_CS_N
3	PCI-E_RESET_N#	4	SPI_PCH_MISO
5	SPI_PCH_CLK#	6	Ground
7	SPI_PCH_MOSI	8	N/A
9	JTPM1_P3V3A	10	IRQ_TPM_SPIN_N

M.2 Slot

The M2-1 connector is an M.2 slot for SSD storage. It is PCIe 4.0 x4 SSD in the 2280 form factor with support of M-Key 2280.

RAID Key Header

A VROC RAID Key header is located at JRK1. It supports VMD used in creating optional advanced NVMe RAID configurations. See the VROC appendix for details.

RAID Key Header Pin Definitions	
Pin#	Definition
1	Ground
2	3.3V Standby
3	Ground
4	PCH_RAID_KEY

I-SATA 3.0 Port (for SBI-420P-1T3N)

The motherboard has one SATA 3.0 port (I-SATA1), which is supported by the Intel C621A PCH. Connect this port to the AOM-SB1-SATA31 add-on module.

HDD2 SATA Activity LED Connector (for SBI-420P-1T3N)

JLED is a 3-pin connector used to indicate the status of HDD2 SATA Activity. Connect JLED to the AOM-SB1-SATA31 add-on module to show HDD2 SATA activity.

4.4 Jumpers

Explanation of Jumpers

To modify the operation of the motherboard, jumpers are used to choose between optional settings. Jumpers create shorts between two pins to change the function associated with it. Pin 1 is identified with a square solder pad on the printed circuit board. See the motherboard layout page for jumper locations.

Note: On a two-pin jumper, "Closed" means the jumper is on both pins and "Open" indicates the jumper is either on only one pin or has been completely removed.

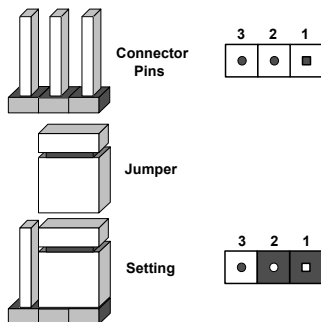

ME Recovery

JPME1 is used for ME Firmware Recovery mode, which will limit system resource for essential function use only without putting restrictions on power use. In the single operation mode, online upgrade will be available in Recovery mode.

ME Recovery Jumper Settings	
Jumper Setting	Definition
Pins 1-2	Normal (Default)
Pins 2-3	ME Recovery

CMOS Clear Contacts

JBT1 is used to clear CMOS. Instead of pins, this jumper consists of contact pads. See Chapter 3 for more information.



4.5 LED Indicators

BMC Heartbeat LED

LEDM1 is a BMC Heartbeat indicator. It blinks green when the BMC is working properly.

M.2 Activity LED

LED1 is an M.2 Activity indicator. When it is blinking green, M.2 is active.

Chapter 5

UEFI BIOS

5.1 Introduction

This chapter describes the AMI UEFI BIOS setup utility for the B12DPT-6 and provides the instructions on navigating the setup screens. The BIOS is stored in a Flash EEPROM and can be updated.

Note: Due to periodic changes to the BIOS, some settings may have been added or deleted since this manual was published.

Starting BIOS Setup Utility

To enter the BIOS setup utility screens, press the <Delete> key while the system is booting up. (There are a few cases when other keys are used, such as <F1>, <F2>, etc.)

The BIOS screens have three main frames. The large left frame displays options can be configured by the user. These are blue. When an option is selected, it is highlighted in white. Settings printed in **Bold** are the default values.

In the left frame, a " ►" indicates a submenu. Highlighting such an item and pressing the <Enter> key opens the list of settings in that submenu.

The upper right frame displays helpful information for the user. The AMI BIOS has default informational messages built in. The manufacturer retains the option to include, omit, or change any of these informational messages.

The lower right frame lists navigational methods. The AMI BIOS setup utility uses a key-based navigation system called *hot keys*. Most of these hot keys can be used at any time during setup navigation. These keys include <F3>, <F4>, <Enter>, <ESC>, arrow keys, etc.

Some system parameters may be changed.

5.2 Main Setup

When running the BIOS setup utility, it starts with the Main screen. You can always return to it by selecting the Main tab on the top of the screen.

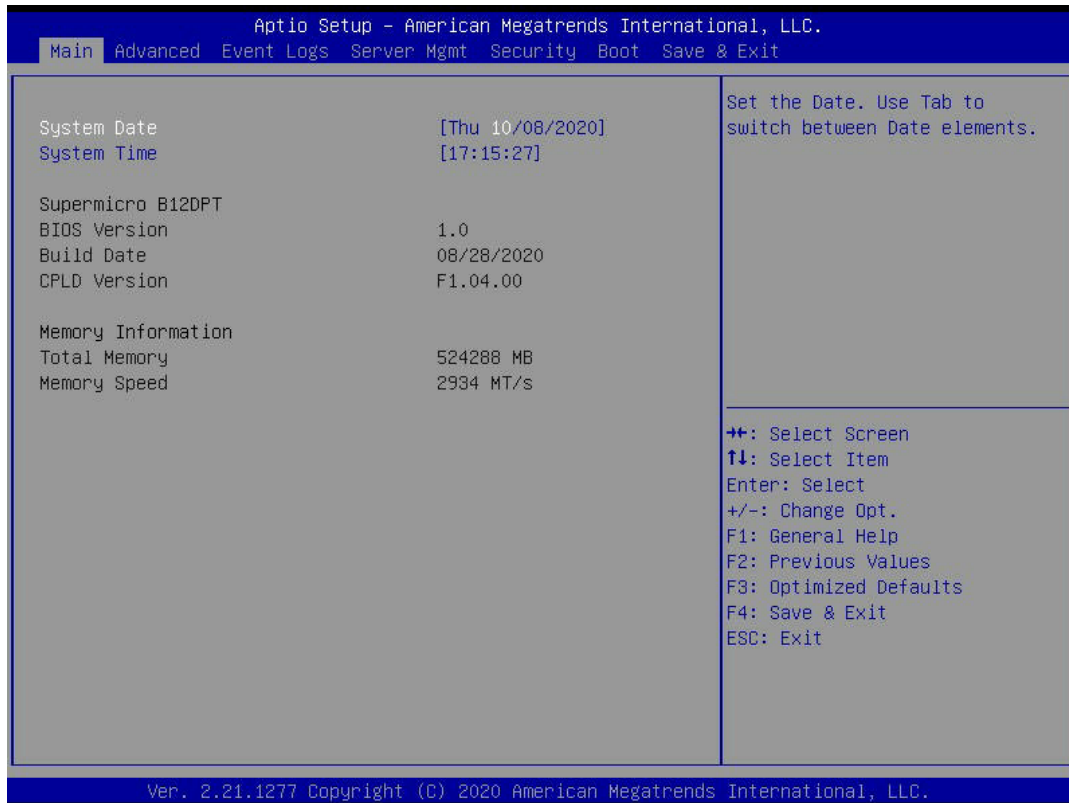

The Main tab page allows you to set the date and time, and it displays system information.

System Date/System Time

Use this option to change the system date and time. Highlight *System Date* or *System Time* using the arrow keys. Enter new values using the keyboard. Press the <Tab> key or the arrow keys to move between fields. The date must be entered in MM/DD/YYYY format. The time is entered in HH:MM:SS format.

Note: The time is in the 24-hour format. For example, 5:30 P.M. appears as 17:30:00. The date's default value is 01/01/2016 after RTC reset.

Supermicro B12DPT-6 (Motherboard model)

BIOS Version

Build Date (of the BIOS)

CPLD (Complex Programmable Logic Device) **Version**

Memory Information

Total Memory (for the system)

Memory Speed

5.3 Tab Pages

Advanced

- Boot Function
- CPU Configuration
- Chipset Configuration
- SATA Configuration
- sSATA Configuration
- PCIe/PCI/PnP Configuration
- Super IO Configuration
- Serial Port Console Redirection
- ACPI Settings
- Trusted Computing
- SIO Common Settings
- T1s Auth Configuration
- All Cpu Information
- RAM Disk Configuration
- iSCSI Configuration
- IPv4 Network Configuration
- VLAN Network Configuration
- IPv6 Network Configuration

Event Logs

- Change SMBIOS Event Log Settings
- ViewSMBOIS Event Log

Server Mgmt

- Serial MUX
- System Event Log
- BMC self test log
- BMC network configuration
- BMC User Settings

Security

- Administrator Password
- Password Check
- Secure Boot

Boot

- Boot Mode Select
- Delete Boot Option
- Delete Driver Optioni
- UEFI Application Boot Priorities
- UEFI NETWORK Drive BBS Priorityies

Save & Exit

- Save Options
- Default Options
- Boot Override

Appendix A

BIOS POST Codes

A.1 BIOS POST Messages

During the Power-On Self-Test (POST), the BIOS will check for problems. If a problem is found, the BIOS will activate an alarm or display a message. The following is a list of such BIOS messages. Not all options may be supported.

BIOS POST Messages	
BIOS Message	Description
Failure Fixed Disk	Fixed disk is not working or not configured properly. Check to see if fixed disk is attached properly. Run Setup. Find out if the fixed-disk type is correctly identified.
Stuck key	Stuck key on keyboard.
Keyboard error	Keyboard not working.
Keyboard Controller Failed	Keyboard controller failed test. May require replacing keyboard controller.
Keyboard locked - Unlock key switch	Unlock the system to proceed.
Monitor type does not match CMOS - Run SETUP	Monitor type not correctly identified in Setup
Shadow Ram Failed at offset: nnnn	Shadow RAM failed at offset nnnn of the 64k block at which the error was detected.
System RAM Failed at offset: nnnn	System RAM failed at offset nnnn of in the 64k block at which the error was detected.
Extended RAM Failed at offset: nnnn	Extended memory not working or not configured properly at offset nnnn.
System battery is dead - Replace and run SETUP	The CMOS clock battery indicator shows the battery is dead. Replace the battery and run Setup to reconfigure the system.
System CMOS checksum bad - Default configuration used	System CMOS has been corrupted or modified incorrectly, perhaps by an application program that changes data stored in CMOS. The BIOS installed Default Setup Values. If you do not want these values, enter Setup and enter your own values. If the error persists, check the system battery or contact your dealer.
System timer error	The timer test failed. Requires repair of system board.
Real time clock error	Real-Time Clock fails BIOS hardware test. May require board repair.
Check date and time settings	BIOS found date or time out of range and reset the Real-Time Clock. May require setting legal date (1991-2099).

BIOS POST Messages	
BIOS Message	Description
Previous boot incomplete - Default configuration used	Previous POST did not complete successfully. POST loads default values and offers to run Setup. If the failure was caused by incorrect values and they are not corrected, the next boot will likely fail. On systems with control of wait states, improper Setup settings can also terminate POST and cause this error on the next boot. Run Setup and verify that the waitstate configuration is correct. This error is cleared the next time the system is booted.
Memory Size found by POST differed from CMOS	Memory size found by POST differed from CMOS.
Diskette drive A error	
Diskette drive B error	Drive A: or B: is present but fails the BIOS POST diskette tests. Check to see that the drive is defined with the proper diskette type in Setup and that the diskette drive is attached correctly.
Incorrect Drive A type - run SETUP	Type of floppy drive A: not correctly identified in Setup.
Incorrect Drive B type - run SETUP	Type of floppy drive B: not correctly identified in Setup.
System cache error - Cache disabled	RAM cache failed and BIOS disabled the cache. On older boards, check the cache jumpers. You may have to replace the cache. See your dealer. A disabled cache slows system performance considerably.
CPU ID:	CPU socket number for Multi-Processor error.
EISA CMOS not writeable	ServerBIOS2 test error: Cannot write to EISA CMOS.
DMA Test Failed	ServerBIOS2 test error: Cannot write to extended DMA (Direct Memory Access) registers.
Software NMI Failed	ServerBIOS2 test error: Cannot generate software NMI (Non-Maskable Interrupt).
Fail-Safe Timer NMI Failed	ServerBIOS2 test error: Fail-Safe Timer takes too long.
device Address Conflict	Address conflict for specified device.
Allocation Error for: device	Run ISA or EISA Configuration Utility to resolve resource conflict for the specified device.
CD ROM Drive	CD ROM Drive identified.
Entering SETUP...	Starting Setup program
Failing Bits: nnnn	The hex number nnnn is a map of the bits at the RAM address which failed the memory test. Each 1 (one) in the map indicates a failed bit. See errors 230, 231, or 232 above for offset address of the failure in System, Extended, or Shadow memory.
Fixed Disk n	Fixed disk n (0-3) identified.
Invalid System Configuration Data	Problem with NVRAM (CMOS) data.
I/O device IRQ conflict	I/O device IRQ conflict error.
PS/2 Mouse Boot Summary Screen:	PS/2 Mouse installed.

BIOS POST Messages	
BIOS Message	Description
nnnn kB Extended RAM Passed	Where nnnn is the amount of RAM in kilobytes successfully tested.
nnnn Cache SRAM Passed	Where nnnn is the amount of system cache in kilobytes successfully tested.
nnnn kB Shadow RAM Passed	Where nnnn is the amount of shadow RAM in kilobytes successfully tested.
nnnn kB System RAM Passed	Where nnnn is the amount of system RAM in kilobytes successfully tested.
One or more I2O Block Storage Devices were excluded from the Setup Boot Menu	There was not enough room in the IPL table to display all installed I2O block-storage devices.
Operating system not found	Operating system cannot be located on either drive A: or drive C:. Enter Setup and see if fixed disk and drive A: are properly identified.
Parity Check 1 nnnn	Parity error found in the system bus. BIOS attempts to locate the address and display it on the screen. If it cannot locate the address, it displays ?????. Parity is a method for checking errors in binary data. A parity error indicates that some data has been corrupted.
Parity Check 2 nnnn	Parity error found in the I/O bus. BIOS attempts to locate the address and display it on the screen. If it cannot locate the address, it displays ?????.
Press <F1> to resume, <F2> to Setup, <F3> for previous	Displayed after any recoverable error message. Press <F1> to start the boot process or <F2> to enter Setup and change the settings. Press <F3> to display the previous screen (usually an initialization error of an Option ROM, i.e., an add-on card). Write down and follow the information shown on the screen.
Press <F2> to enter Setup	Optional message displayed during POST. Can be turned off in Setup.
PS/2 Mouse:	PS/2 mouse identified.
Run the I2O Configuration Utility	One or more unclaimed block storage devices have the Configuration Request bit set in the LCT. Run an I2O Configuration Utility (e.g. the SAC utility).
System BIOS shadowed	System BIOS copied to shadow RAM.
UMB upper limit segment address: nnnn	Displays the address nnnn of the upper limit of Upper Memory Blocks, indicating released segments of the BIOS which can be reclaimed by a virtual memory manager.
Video BIOS shadowed	Video BIOS successfully copied to shadow RAM.

A.2 BIOS POST Codes

This section lists the POST (Power-On Self-Test) codes for the AMI BIOS. POST codes are divided into two categories: recoverable and terminal.

Recoverable POST Errors

When a recoverable type of error occurs during POST, the BIOS will display an POST code that describes the problem. BIOS may also issue one of the following beep codes:

One long and two short beeps – video configuration error

One repetitive long beep – no memory detected

Terminal POST Errors

If a terminal type of error occurs, BIOS will shut down the system. Before doing so, BIOS will write the error to port 80h, attempt to initialize video and write the error in the top left corner of the screen.

The following is a list of codes that may be written to port 80h.

Terminal POST Errors	
Code	Description
02h	Verify Real Mode
03h	Disable Non-Maskable Interrupt (NMI)
04h	Get CPU type
06h	Initialize system hardware
07h	Disable shadow and execute code from the ROM.
08h	Initialize chipset with initial POST values
09h	Set IN POST flag
0Ah	Initialize CPU registers
0Bh	Enable CPU cache
0Ch	Initialize caches to initial POST values
0Eh	Initialize I/O component
0Fh	Initialize the local bus IDE
10h	Initialize Power Management
11h	Load alternate registers with initial POST values
12h	Restore CPU control word during warm boot
13h	Initialize PCI Bus Mastering devices
14h	Initialize keyboard controller
16h	1-2-2-3 BIOS ROM checksum
17h	Initialize cache before memory Auto size
18h	8254 timer initialization
1Ah	8237 DMA controller initialization
1Ch	Reset Programmable Interrupt Controller

Terminal POST Errors	
Code	Description
20h	1-3-1-1 Test DRAM refresh
22h	1-3-1-3 Test 8742 Keyboard Controller
28h	Auto size DRAM
29h	Initialize POST Memory Manager
2Ah	Clear 512 kB base RAM
2Ch	1-3-4-1 RAM failure on address line xxxx*
2Eh	1-3-4-3 RAM failure on data bits xxxx* of low byte of memory bus
2Fh	Enable cache before system BIOS shadow
32h	Test CPU bus-clock frequency
33h	Initialize Phoenix Dispatch Manager
36h	Warm start shut down
38h	Shadow system BIOS ROM
3Ah	Auto size cache
3Ch	Advanced configuration of chipset registers
3Dh	Load alternate registers with CMOS values
41h	Initialize extended memory for RomPilot
42h	Initialize interrupt vectors
45h	POST device initialization
46h	2-1-2-3 Check ROM copyright notice
47h	Initialize I20 support
48h	Check video configuration against CMOS
49h	Initialize PCI bus and devices
4Ah	Initialize all video adapters in system
4Bh	QuietBoot start (optional)
4Ch	Shadow video BIOS ROM
4Eh	Display BIOS copyright notice
4Fh	Initialize MultiBoot
50h	Display CPU type and speed
51h	Initialize EISA board

Terminal POST Errors	
Code	Description
52h	Test keyboard
54h	Set key click if enabled
55h	Enable USB devices
58h	2-2-3-1 Test for unexpected interrupts
59h	Initialize POST display service
5Ah	Display prompt "Press F2 to enter SETUP"
5Bh	Disable CPU cache
5Ch	Test RAM between 512 and 640 kB
60h	Test extended memory
62h	Test extended memory address lines
64h	Jump to UserPatch1
66h	Configure advanced cache registers
67h	Initialize Multi Processor APIC
68h	Enable external and CPU caches
69h	Setup System Management Mode (SMM) area
6Ah	Display external L2 cache size
6Bh	Load custom defaults (optional)
6Ch	Display shadow-area message
6Eh	Display possible high address for UMB recovery
70h	Display error messages
72h	Check for configuration errors
76h	Check for keyboard errors
7Ch	Set up hardware interrupt vectors
7Dh	Initialize Intelligent System Monitoring
7Eh	Initialize coprocessor if present
80h	Disable onboard Super I/O ports and IRQs
81h	Late POST device initialization
82h	Detect and install external RS232 ports
83h	Configure non-MCD IDE controllers

Terminal POST Errors	
Code	Description
84h	Detect and install external parallel ports
85h	Initialize PC-compatible PnP ISA devices
86h	Re-initialize onboard I/O ports.
87h	Configure Motherboard Configurable Devices (optional)
88h	Initialize BIOS Data Area
89h	Enable Non-Maskable Interrupts (NMIs)
8Ah	Initialize Extended BIOS Data Area
8Bh	Test and initialize PS/2 mouse
8Ch	Initialize floppy controller
8Fh	Determine number of ATA drives (optional)
90h	Initialize hard-disk controllers
91h	Initialize local-bus hard-disk controllers
92h	Jump to UserPatch2
93h	Build MPTABLE for multi-processor boards
95h	Install CD ROM for boot
96h	Clear huge ES segment register
98h	1-2 Search for option ROMs. One long, two short beeps on check-sum failure
99h	Check for SMART Drive (optional)
9Ah	Shadow option ROMs
9Ch	Set up Power Management
9Dh	Initialize security engine (optional)
9Eh	Enable hardware interrupts
9Fh	Determine number of ATA and SCSI drives
A0h	Set time of day
A2h	Check key lock
A4h	Initialize typematic rate
A8h	Erase F2 prompt
AAh	Scan for F2 key stroke
ACh	Enter SETUP

Terminal POST Errors	
Code	Description
AEh	Clear Boot flag
B0h	Check for errors
B1h	Inform RomPilot about the end of POST.
B2h	POST done - prepare to boot operating system
B4h	1 One short beep before boot
B5h	Terminate QuietBoot (optional)
B6h	Check password (optional)
B7h	Initialize ACPI BIOS
B9h	Prepare Boot
BAh	Initialize SMBIOS
BBh	Initialize PnP Option ROMs
BCh	Clear parity checkers
BDh	Display MultiBoot menu
BEh	Clear screen (optional)
BFh	Check virus and backup reminders
C0h	Try to boot with INT 19
C1h	Initialize POST Error Manager (PEM)
C2h	Initialize error logging
C3h	Initialize error display function
C4h	Initialize system error handler
C5h	PnPnd dual CMOS (optional)
C6h	Initialize note dock (optional)
C7h	Initialize note dock late
C8h	Force check (optional)
C9h	Extended checksum (optional)
CAh	Redirect Int 15h to enable remote keyboard
CBh	Redirect Int 13h to Memory Technologies Devices such as ROM, RAM, PCMCIA, and serial disk
CCh	Redirect Int 10h to enable remote serial video
CDh	Re-map I/O and memory for PCMCIA

Terminal POST Errors	
Code	Description
CEh	Initialize digitizer and display message
D2h	Unknown interrupt

The following are for the boot block in Flash ROM:

Boot Block Flash ROM Terminal POST Errors	
Code	Description
E0h	Initialize the chipset
E1h	Initialize the bridge
E2h	Initialize the CPU
E3h	Initialize system timer
E4h	Initialize system I/O
E5h	Check force recovery boot
E6h	Checksum BIOS ROM
E7h	Go to BIOS
E8h	Set Huge Segment
E9h	Initialize Multi Processor
EAh	Initialize OEM special code
EBh	Initialize PIC and DMA
ECh	Initialize Memory type
EDh	Initialize Memory size
EEh	Shadow Boot Block
EFh	System memory test

Boot Block Flash ROM Terminal POST Errors	
Code	Description
F0h	Initialize interrupt vectors
F1h	Initialize Run Time Clock
F2h	Initialize video
F3h	Initialize System Management Manager
F4h	Output one beep
F5h	Clear Huge Segment
F6h	Boot to Mini DOS
F7h	Boot to Full DOS

If the BIOS detects error 2C, 2E, or 30 (base 512K RAM error), it displays an additional word-bitmap (xxxx) indicating the address line or bits that failed. For example, "2C 0002" means address line 1 (bit one set) has failed. "2E 1020" means data bits 12 and 5 (bits 12 and 5 set) have failed in the lower 16 bits. The BIOS also sends the bitmap to the port-80 LED display. It first displays the checkpoint code, followed by a delay, the high-order byte, another delay, and then the low order byte of the error. It repeats this sequence continuously.

Appendix B

Standardized Warning Statements for AC Systems

About Standardized Warning Statements

The following statements are industry standard warnings, provided to warn the user of situations which have the potential for bodily injury. Should you have questions or experience difficulty, contact Supermicro's Technical Support department for assistance. Only certified technicians should attempt to install or configure components.

Read this appendix in its entirety before installing or configuring components in the Supermicro chassis.

These warnings may also be found on our website at http://www.supermicro.com/about/policies/safety_information.cfm.

Warning Definition



Warning! This warning symbol means danger. You are in a situation that could cause bodily injury. Before you work on any equipment, be aware of the hazards involved with electrical circuitry and be familiar with standard practices for preventing accidents.

警告の定義

この警告サインは危険を意味します。

人身事故につながる可能性がありますので、いずれの機器でも動作させる前に、電気回路に含まれる危険性に注意して、標準的な事故防止策に精通して下さい。

此警告符号代表危險。

您正处于可能受到严重伤害的工作环境中。在您使用设备开始工作之前，必须充分意识到触电的危险，并熟练掌握防止事故发生的标准工作程序。请根据每项警告结尾的声明号码找到此设备的安全性警告说明的翻译文本。

此警告符號代表危險。

您正處於可能身體可能會受損傷的工作環境中。在您使用任何設備之前，請注意觸電的危險，並且要熟悉預防事故發生的標準工作程序。請依照每一注意事項後的號碼找到相關的翻譯說明內容。

Warnung

WICHTIGE SICHERHEITSHINWEISE

Dieses Warnsymbol bedeutet Gefahr. Sie befinden sich in einer Situation, die zu Verletzungen führen kann. Machen Sie sich vor der Arbeit mit Geräten mit den Gefahren elektrischer Schaltungen und den üblichen Verfahren zur Vorbeugung vor Unfällen vertraut. Suchen Sie mit der am Ende jeder Warnung angegebenen Anweisungsnummer nach der jeweiligen Übersetzung in den übersetzten Sicherheitshinweisen, die zusammen mit diesem Gerät ausgeliefert wurden.

BEWAHREN SIE DIESE HINWEISE GUT AUF.

INSTRUCCIONES IMPORTANTES DE SEGURIDAD

Este símbolo de aviso indica peligro. Existe riesgo para su integridad física. Antes de manipular cualquier equipo, considere los riesgos de la corriente eléctrica y familiarícese con los procedimientos estándar de prevención de accidentes. Al final de cada advertencia encontrará el número que le ayudará a encontrar el texto traducido en el apartado de traducciones que acompaña a este dispositivo.

GUARDE ESTAS INSTRUCCIONES.

IMPORTANTES INFORMATIONS DE SÉCURITÉ

Ce symbole d'avertissement indique un danger. Vous vous trouvez dans une situation pouvant entraîner des blessures ou des dommages corporels. Avant de travailler sur un équipement, soyez conscient des dangers liés aux circuits électriques et familiarisez-vous avec les procédures couramment utilisées pour éviter les accidents. Pour prendre connaissance des traductions des avertissements figurant dans les consignes de sécurité traduites qui accompagnent cet appareil, référez-vous au numéro de l'instruction situé à la fin de chaque avertissement.

CONSERVEZ CES INFORMATIONS.

תקנון הזהרות אזהרה

הזהרות הבאות הן אזהרות על פי תקני התעשייה, על מנת להזהיר את המשתמש מפני חבלה פיזית אפשרית. במידה ויש שאלות או היתקלות בבעיה כלשהי, יש ליצור קשר עם מחלקת תמיכה טכנית של סופרמיקרו. טכנאים מוסמכים בלבד רשאים להתקין או להגדיר את הרכיבים. יש לקרוא את הנספח במלואו לפני התקנת או הגדרת הרכיבים במארזי סופרמיקרו.

اَكْ ف حالة وُكِي اَي تتسبب ف اصابة جسدهُ هذا الزهز عْ خطر! تحذُرُ .
قبل اَي تعول على اَي هعدات، كي على علن بالوخاطز ال اُجوة عي الذوائر
الكهزبائِة
وكي على دراةُ بالووارسات النقاىِة لو عْ وقع اَي حادث
استخدم رقن الب اى الو صُص ف هاةُ كل تحذُر للعشر تزجوتها

안전을 위한 주의사항

경고!

이 경고 기호는 위험이 있음을 알려 줍니다. 작업자의 신체에 부상을 야기 할 수 있는 상태에 있게 됩니다. 모든 장비에 대한 작업을 수행하기 전에 전기회로와 관련된 위험요소들을 확인하시고 사전에 사고를 방지할 수 있도록 표준 작업절차를 준수해 주시기 바랍니다.

해당 번역문을 찾기 위해 각 경고의 마지막 부분에 제공된 경고문 번호를 참조하십시오

BELANGRIJKE VEILIGHEIDSINSTRUCTIES

Dit waarschuwings symbool betekent gevaar. U verkeert in een situatie die lichamelijk letsel kan veroorzaken. Voordat u aan enige apparatuur gaat werken, dient u zich bewust te zijn van de bij een elektrische installatie betrokken risico's en dient u op de hoogte te zijn van de standaard procedures om ongelukken te voorkomen. Gebruik de nummers aan het eind van elke waarschuwing om deze te herleiden naar de desbetreffende locatie.

BEWAAR DEZE INSTRUCTIES

Installation Instructions



Warning! Read the installation instructions before connecting the system to the power source.

設置手順書

システムを電源に接続する前に、設置手順書をお読み下さい。

警告

将此系统连接电源前,请先阅读安装说明。

警告

將系統與電源連接前，請先閱讀安裝說明。

Warnung

Vor dem Anschließen des Systems an die Stromquelle die Installationsanweisungen lesen.

¡Advertencia!

Lea las instrucciones de instalación antes de conectar el sistema a la red de alimentación.

Attention

Avant de brancher le système sur la source d'alimentation, consulter les directives d'installation.

יש לקרוא את הוראות התקנה לפני חיבור המערכת למקור מתח.

اقرأ إرشادات التركيب قبل توصيل النظام إلى مصدر للطاقة

시스템을 전원에 연결하기 전에 설치 안내를 읽어주십시오.

Waarschuwing

Raadpleeg de installatie-instructies voordat u het systeem op de voedingsbron aansluit.

Circuit Breaker



Warning! This product relies on the building's installation for short-circuit (overcurrent) protection. Ensure that the protective device is rated not greater than: 250 V, 20 A.

サーキット・ブレーカー

この製品は、短絡(過電流)保護装置がある建物での設置を前提としています。

保護装置の定格が250 V、20 Aを超えないことを確認下さい。

警告

此产品的短路(过载电流)保护由建筑物的供电系统提供,确保短路保护设备的额定电流不大于250V,20A。

警告

此產品的短路(過載電流)保護由建築物的供電系統提供,確保短路保護設備的額定電流不大於250V,20A。

Warnung

Dieses Produkt ist darauf angewiesen, dass im Gebäude ein Kurzschluss- bzw. Überstromschutz installiert ist. Stellen Sie sicher, dass der Nennwert der Schutzvorrichtung nicht mehr als: 250 V, 20 A beträgt.

¡Advertencia!

Este equipo utiliza el sistema de protección contra cortocircuitos (o sobrecorrientes) del edificio. Asegúrese de que el dispositivo de protección no sea superior a: 250 V, 20 A.

Attention

Pour ce qui est de la protection contre les courts-circuits (surtension), ce produit dépend de l'installation électrique du local. Vérifiez que le courant nominal du dispositif de protection n'est pas supérieur à :250 V, 20 A.

מוצר זה מסתמך על הגנה המותקנת במבנים למניעת קצר חשמלי. יש לוודא כי המכשיר המגן מפני הקצר החשמלי הוא לא יותר מ-250VDC, 20A

هذا المنتج يعتمد على معدات الحماية من الدوائر القصيرة التي تم تثبيتها في المبنى
تأكد من أن تقييم الجهاز الوقائي ليس أكثر من : 20A, 250V

경고!

이 제품은 전원의 단락(과전류)방지에 대해서 전적으로 건물의 관련 설비에 의존합니다. 보호장치의 정격이 반드시 250V(볼트), 20A(암페어)를 초과하지 않도록 해야 합니다.

Waarschuwing

Dit product is afhankelijk van de kortsluitbeveiliging (overspanning) van uw elektrische installatie. Controleer of het beveiligde apparaat niet groter gedimensioneerd is dan 250V, 20A.

Power Disconnection Warning



Warning! The system must be disconnected from all sources of power and the power cord removed from the power supply module(s) before accessing the chassis interior to install or remove system components.



電源切断の警告

システムコンポーネントの取り付けまたは取り外しのために、シャーシ内部にアクセスするには、システムの電源はすべてのソースから切断され、電源コードは電源モジュールから取り外す必要があります。

警告

在你打开机箱并安装或移除内部器件前,必须将系统完全断电,并移除电源线。

警告

在您打開機殼安裝或移除內部元件前，必須將系統完全斷電，並移除電源線。

Warnung

Das System muss von allen Quellen der Energie und vom Netzanschlusskabel getrennt sein, das von den Spg.Versorgungsteilmodulen entfernt wird, bevor es auf den Chassisinnenraum zurückgreift, um Systemsbestandteile anzubringen oder zu entfernen.

¡Advertencia!

El sistema debe ser disconnected de todas las fuentes de energía y del cable eléctrico quitado de los módulos de fuente de alimentación antes de tener acceso el interior del chasis para instalar o para quitar componentes de sistema.

Attention

Le système doit être débranché de toutes les sources de puissance ainsi que de son cordon d'alimentation secteur avant d'accéder à l'intérieur du chasis pour installer ou enlever des composants de système.

אזהרה מפני ניתוק חשמלי

אזהרה!

יש לנתק את המערכת מכל מקורות החשמל ויש להסיר את כבל החשמלי מהספק לפני גישה לחלק הפנימי של המארז לצורך התקנת או הסרת רכיבים.

يجب فصل انظاؤ من جميع مصادر انطاقت وإزانت سهك انكهرباء من وحدة امداد انطاقت قيم

انصل إني امنطاقت انداخييت نههيكم ننتبيح أو إزانت مكناث الجهاز

경고!

시스템에 부품들을 장착하거나 제거하기 위해서는 새시 내부에 접근하기 전에 반드시 전원 공급장치로부터 연결되어있는 모든 전원과 전기코드를 분리해주어야 합니다.

Waarschuwing

Voordat u toegang neemt tot het binnenwerk van de behuizing voor het installeren of verwijderen van systeem onderdelen, dient u alle spanningsbronnen en alle stroomkabels aangesloten op de voeding(en) van de behuizing te verwijderen

Equipment Installation



Warning! Only trained and qualified personnel should be allowed to install, replace, or service this equipment.

機器の設置

トレーニングを受け認定された人だけがこの装置の設置、交換、またはサービスを許可されていません。

警告

只有经过培训且具有资格的人员才能进行此设备的安装、更换和维修。

警告

只有經過受訓且具資格人員才可安裝、更換與維修此設備。

Warnung

Das Installieren, Ersetzen oder Bedienen dieser Ausrüstung sollte nur geschultem, qualifiziertem Personal gestattet werden.

¡Advertencia!

Solamente el personal calificado debe instalar, reemplazar o utilizar este equipo.

Attention

Il est vivement recommandé de confier l'installation, le remplacement et la maintenance de ces équipements à des personnels qualifiés et expérimentés.

אזהרה!

צוות מוסמך בלבד רשאי להתקין, להחליף את הציוד או לתת שירות עבור הציוד.

والمدربيه لتزكيب واستبدال أو خدمة هذا الجهاز يجب أن يسمح فقط للمظفيه المؤهليه

경고!

훈련을 받고 공인된 기술자만이 이 장비의 설치, 교체 또는 서비스를 수행할 수 있습니다.

Waarschuwing

Deze apparatuur mag alleen worden geïnstalleerd, vervangen of hersteld door geschoold en gekwalificeerd personeel.

Restricted Area



Warning! This unit is intended for installation in restricted access areas. A restricted access area can be accessed only through the use of a special tool, lock and key, or other means of security. (This warning does not apply to workstations).

アクセス制限区域

このユニットは、アクセス制限区域に設置されることを想定しています。

アクセス制限区域は、特別なツール、鍵と錠前、その他のセキュリティの手段を用いてのみ出入りが可能です。

警告

此部件应安装在限制进出的场所，限制进出的场所指只能通过使用特殊工具、锁和钥匙或其它安全手段进出的场所。

警告

此裝置僅限安裝於進出管制區域，進出管制區域係指僅能以特殊工具、鎖頭及鑰匙或其他安全方式才能進入的區域。

Warnung

Diese Einheit ist zur Installation in Bereichen mit beschränktem Zutritt vorgesehen. Der Zutritt zu derartigen Bereichen ist nur mit einem Spezialwerkzeug, Schloss und Schlüssel oder einer sonstigen Sicherheitsvorkehrung möglich.

¡Advertencia!

Esta unidad ha sido diseñada para instalación en áreas de acceso restringido. Sólo puede obtenerse acceso a una de estas áreas mediante la utilización de una herramienta especial, cerradura con llave u otro medio de seguridad.

Attention

Cet appareil doit être installée dans des zones d'accès réservés. L'accès à une zone d'accès réservé n'est possible qu'en utilisant un outil spécial, un mécanisme de verrouillage et une clé, ou tout autre moyen de sécurité.

אזור עם גישה מוגבלת

אזהרה!

יש להתקין את היחידה באזורים שיש בהם הגבלת גישה. הגישה ניתנת בעזרת 'כלי אבטחה בלבד' (מפתח, מנעול וכד.).

تخصيص هذه انحدة نترك بُها ف مناطق محظورة تم .
،مكن اننصل إن منطقت محظورة فقط من خلال استخذاو أداة خاصت
أو أ وس هُت أخري نلالأمما ققم ومفتاح

경고!

이 장치는 접근이 제한된 구역에 설치하도록 되어있습니다. 특수도구, 잠금 장치 및 키, 또는 기타 보안 수단을 통해서만 접근 제한 구역에 들어갈 수 있습니다.

Waarschuwing

Dit apparaat is bedoeld voor installatie in gebieden met een beperkte toegang. Toegang tot dergelijke gebieden kunnen alleen verkregen worden door gebruik te maken van speciaal gereedschap, slot en sleutel of andere veiligheidsmaatregelen.

Battery Handling



Warning! There is the danger of explosion if the battery is replaced incorrectly. Replace the battery only with the same or equivalent type recommended by the manufacturer. Dispose of used batteries according to the manufacturer's instructions

電池の取り扱い

電池交換が正しく行われなかった場合、破裂の危険性があります。交換する電池はメーカーが推奨する型、または同等のものを使用下さい。使用済電池は製造元の指示に従って処分して下さい。

警告

電池更換不當會有爆炸危險。請只使用同類電池或制造商推薦的功能相當的電池更換原有電池。請按製造商的說明處理廢舊電池。

警告

電池更換不當會有爆炸危險。請使用製造商建議之相同或功能相當的電池更換原有電池。請按照製造商的說明指示處理廢棄舊電池。

Warnung

Bei Einsetzen einer falschen Batterie besteht Explosionsgefahr. Ersetzen Sie die Batterie nur durch den gleichen oder vom Hersteller empfohlenen Batterietyp. Entsorgen Sie die benutzten Batterien nach den Anweisungen des Herstellers.

Attention

Danger d'explosion si la pile n'est pas remplacée correctement. Ne la remplacer que par une pile de type semblable ou équivalent, recommandée par le fabricant. Jeter les piles usagées conformément aux instructions du fabricant.

¡Advertencia!

Existe peligro de explosión si la batería se reemplaza de manera incorrecta. Reemplazar la batería exclusivamente con el mismo tipo o el equivalente recomendado por el fabricante. Desechar las baterías gastadas según las instrucciones del fabricante.

אזהרה!

קיימת סכנת פיצוץ של הסוללה במידה והוחלפה בדרך לא תקינה. יש להחליף את הסוללה בסוג התואם מחברת יצרן מומלצת. סילוק הסוללות המשומשות יש לבצע לפי הוראות היצרן.

هناك خطر من انفجار في حالة اسبدال البطارية بطريقة غير صحيحة فعلى
اسبدال البطارية
فقط بنفس النوع أو ما يعادلها مما أوصت به الشركة المصنعة
جخلص من البطاريات المسحومة وفقا لعمليات الشركة الصانعة

경고!

배터리가 올바르게 교체되지 않으면 폭발의 위험이 있습니다. 기존 배터리와 동일하거나 제조사에서 권장하는 동등한 종류의 배터리로만 교체해야 합니다. 제조사의 안내에 따라 사용된 배터리를 처리하여 주십시오.

Waarschuwing

Er is ontplofingsgevaar indien de batterij verkeerd vervangen wordt. Vervang de batterij slechts met hetzelfde of een equivalent type die door de fabrikant aanbevolen wordt. Gebruikte batterijen dienen overeenkomstig fabrieksvoorschriften afgevoerd te worden.

Redundant Power Supplies



Warning! This unit might have more than one power supply connection. All connections must be removed to de-energize the unit.

冗長電源装置

このユニットは複数の電源装置が接続されている場合があります。

ユニットの電源を切るためには、すべての接続を取り外さなければなりません。

警告

此部件连接的电源可能不止一个，必须将所有电源断开才能停止给该部件供电。

警告

此装置连接的电源可能不只一个，必须切断所有电源才能停止对该装置的供电。

Warnung

Dieses Gerät kann mehr als eine Stromzufuhr haben. Um sicherzustellen, dass der Einheit kein Strom zugeführt wird, müssen alle Verbindungen entfernt werden.

¡Advertencia!

Puede que esta unidad tenga más de una conexión para fuentes de alimentación. Para cortar por completo el suministro de energía, deben desconectarse todas las conexiones.

Attention

Cette unité peut avoir plus d'une connexion d'alimentation. Pour supprimer toute tension et tout courant électrique de l'unité, toutes les connexions d'alimentation doivent être débranchées.

אם קיים יותר מספק אחד

אזהרה!

ליחידה יש יותר מחיבור אחד של ספק. יש להסיר את כל החיבורים על מנת לרוקן את היחידה.

قد يكون لهذا الجهاز عدة اتصالات بوحدات امداد الطاقة .
يجب إزالة كافة الاتصالات لعسل الوحدة عن الكهرباء

경고!

이 장치에는 한 개 이상의 전원 공급 단자가 연결되어 있을 수 있습니다. 이 장치에 전원을 차단하기 위해서는 모든 연결 단자를 제거해야만 합니다.

Waarschuwing

Deze eenheid kan meer dan één stroomtoevoeraansluiting bevatten. Alle aansluitingen dienen verwijderd te worden om het apparaat stroomloos te maken.

Backplane Voltage



Warning! Hazardous voltage or energy is present on the backplane when the system is operating. Use caution when servicing.

バックプレーンの電圧

システムの稼働中は危険な電圧または電力が、バックプレーン上にかかっています。

修理する際には注意ください。

警告

当システム正在进行时，背板上有很危险的电压或能量，进行维修时务必小心。

警告

當系統正在進行時，背板上危險的電壓或能量，進行維修時務必小心。

Warnung

Wenn das System in Betrieb ist, treten auf der Rückwandplatine gefährliche Spannungen oder Energien auf. Vorsicht bei der Wartung.

¡Advertencia!

Cuando el sistema está en funcionamiento, el voltaje del plano trasero es peligroso. Tenga cuidado cuando lo revise.

Attention

Lorsque le système est en fonctionnement, des tensions électriques circulent sur le fond de panier. Prendre des précautions lors de la maintenance.

מתח בפנל האחורי

אזהרה!

קיימת סכנת מתח בפנל האחורי בזמן תפעול המערכת. יש להיזהר במהלך העבודה.

هناك خطر من التيار الكهربائي أو الطاقة المتجددة على اللوحة
عندما يكون النظام يعمل كه حذرا عند خدمة هذا الجهاز

경고!

시스템이 동작 중일 때 후면판 (Backplane)에는 위험한 전압이나 에너지가 발생 합니다.
서비스 작업 시 주의하십시오.

Waarschuwing

Een gevaarlijke spanning of energie is aanwezig op de backplane wanneer het systeem in gebruik is. Voorzichtigheid is geboden tijdens het onderhoud.

Comply with Local and National Electrical Codes



Warning! Installation of the equipment must comply with local and national electrical codes.

地方および国の電気規格に準拠

機器の取り付けはその地方および国の電気規格に準拠する必要があります。

警告

设备安装必须符合本地与本国电气法规。

警告

設備安裝必須符合本地與本國電氣法規。

Warnung

Die Installation der Geräte muss den Sicherheitsstandards entsprechen.

¡Advertencia!

La instalación del equipo debe cumplir con las normas de electricidad locales y nacionales.

Attention

L'équipement doit être installé conformément aux normes électriques nationales et locales.

תיאום חוקי החשמל הארצי

אזהרה!

התקנת הציוד חייבת להיות תואמת לחוקי החשמל המקומיים והארציים.

تركيب المعدات الكهربائية يجب أن يمتثل للقوايه المحلية والبطية المتعلقة

بالكهرباء

경고!

현 지역 및 국가의 전기 규정에 따라 장비를 설치해야 합니다.

Waarschuwing

Bij installatie van de apparatuur moet worden voldaan aan de lokale en nationale elektriciteitsvoorschriften.

Product Disposal



Warning! Ultimate disposal of this product should be handled according to all national laws and regulations.

製品の廃棄

この製品を廃棄処分する場合、国の関係する全ての法律・条例に従い処理する必要があります。

警告

本产品的废弃处理应根据所有国家的法律和规章进行。

警告

本產品的廢棄處理應根據所有國家的法律和規章進行。

Warnung

Die Entsorgung dieses Produkts sollte gemäß allen Bestimmungen und Gesetzen des Landes erfolgen.

¡Advertencia!

Al deshacerse por completo de este producto debe seguir todas las leyes y reglamentos nacionales.

Attention

La mise au rebut ou le recyclage de ce produit sont généralement soumis à des lois et/ou directives de respect de l'environnement. Renseignez-vous auprès de l'organisme compétent.

סילוק המוצר

אזהרה!

סילוק סופי של מוצר זה חייב להיות בהתאם להנחיות וחוקי המדינה.

التخلص النهائي من هذا المنتج ينبغي التعامل معه وفقا لجميع القوانين واللوائح الوطنية عند

경고!

이 제품은 해당 국가의 관련 법규 및 규정에 따라 폐기되어야 합니다.

Waarschuwing

De uiteindelijke verwijdering van dit product dient te geschieden in overeenstemming met alle nationale wetten en reglementen.

Hot Swap Fan Warning



Warning! Hazardous moving parts. Keep away from moving fan blades. The fans might still be turning when you remove the fan assembly from the chassis. Keep fingers, screwdrivers, and other objects away from the openings in the fan assembly's housing.

ファン・ホットスワップの警告

警告!回転部品に注意。運転中は回転部(羽根)に触れないでください。シャーシから冷却ファン装置を取り外した際、ファンがまだ回転している可能性があります。ファンの開口部に、指、ドライバー、およびその他のものを近づけないで下さい。

警告!

警告! 危險的可移動性零件。請務必與轉動的风扇叶片保持距離。當您從機架移除風扇裝置，風扇可能仍在轉動。小心不要將手指、螺絲起子和其他物品太靠近風扇

警告

危險的可移動性零件。請務必與轉動的风扇叶片保持距離。當您從機架移除風扇裝置，風扇可能仍在轉動。小心不要將手指、螺絲起子和其他物品太靠近風扇。

Warnung

Gefährlich Bewegende Teile. Von den bewegenden Lüfterblätter fern halten. Die Lüfter drehen sich u. U. noch, wenn die Lüfterbaugruppe aus dem Chassis genommen wird. Halten Sie Finger, Schraubendreher und andere Gegenstände von den Öffnungen des Lüftergehäuses entfernt.

¡Advertencia!

Riesgo de piezas móviles. Mantener alejado de las aspas del ventilador. Los ventiladores podran dar vuelta cuando usted quite el montaje del ventilador del chasis. Mantenga los dedos, los destornilladores y todos los objetos lejos de las aberturas del ventilador

Attention

Pieces mobiles dangereuses. Se tenir a l'écart des lames du ventilateur Il est possible que les ventilateurs soient toujours en rotation lorsque vous retirerez le bloc ventilateur du châssis. Prenez garde à ce que doigts, tournevis et autres objets soient éloignés du logement du bloc ventilateur.

אזהרה!

חלקים נעים מסוכנים. התרחק מלהבי המאוורר בפעולה כאשר מסירים את חלקי המאוורר מהמארז, יתכן והמאווררים עדיין עובדים. יש להרחיק למרחק בטוח את האצבעות וכלי עבודה שונים מהפתחים בתוך המאוורר

تحذير! أجزاء متحركة خطيرة. ابتعد عن شفرات المروحة المتحركة. من الممكن أن المراوح لا تزال تدور عند إزالة كتلة المروحة من الهيكل يجب إبقاء الأصابع ومفكات البراغي وغيرها من الأشياء بعيدا عن الفتحات في كتلة المروحة

경고!

움직이는 위험한 부품. 회전하는 송풍 날개에 접근하지 마세요. 새시로부터 팬 조립품을 제거할 때 팬은 여전히 회전하고 있을 수 있습니다. 팬 조립품 외관의 열려있는 부분들로부터 손가락 및 스크류드라이버, 다른 물체들이 가까이 하지 않도록 배치해 주십시오.

Waarschuwing

Gevaarlijk bewegende onderdelen. Houd voldoende afstand tot de bewegende ventilatorbladen. Het is mogelijk dat de ventilator nog draait tijdens het verwijderen van het ventilatorsamenstel uit het chassis. Houd uw vingers, schroevendraaiers en eventuele andere voorwerpen uit de buurt van de openingen in de ventilatorbehuizing.

Power Cable and AC Adapter



Warning! When installing the product, use the provided or designated connection cables, power cables and AC adaptors. Using any other cables and adaptors could cause a malfunction or a fire. Electrical Appliance and Material Safety Law prohibits the use of UL or CSA -certified cables (that have UL/CSA shown on the cord) for any other electrical devices than products designated by Supermicro only.

電源コードとACアダプター

製品を設置する場合、提供または指定および購入された接続ケーブル、電源コードとACアダプターを、該当する地域の条例や安全基準に適合するコードサイズやプラグと共に使用下さい。他のケーブルやアダプタを使用すると故障や火災の原因になることがあります。

電気用品安全法は、ULまたはCSA認定のケーブル(UL/CSAマークがコードに表記)を Supermicro が指定する製品以外に使用することを禁止しています。

警告

安装此产品时,请使用本身提供的或指定的或采购的连接线,电源线和电源适配器。包含遵照当地法规和安全要求的合规的电源线尺寸和插头。使用其它线材或适配器可能会引起故障或火灾。除了Supermicro所指定的产品,电气用品和材料安全法律规定禁止使用未经UL或CSA认证的线材。(线材上会显示UL/CSA符号)。

警告

安裝此產品時,請使用本身提供的或指定的或採購的連接線,電源線和電源適配器。包含遵照當地法規和安全要求的合規的電源線尺寸和插頭。使用其它線材或適配器可能會引起故障或火災。除了Supermicro所指定的產品,電氣用品和材料安全法律規定禁止使用未經UL或CSA認證的線材。(線材上會顯示UL/CSA符號)。

Warnung

Nutzen Sie beim Installieren des Produkts ausschließlich die von uns zur Verfügung gestellten Verbindungskabeln, Stromkabeln und/oder Adapter, die Ihre örtlichen Sicherheitsstandards einhalten. Der Gebrauch von anderen Kabeln und Adapter können Fehlfunktionen oder Feuer verursachen. Die Richtlinien untersagen das Nutzen von UL oder CAS zertifizierten Kabeln (mit UL/CSA gekennzeichnet), an Geräten oder Produkten die nicht mit Supermicro gekennzeichnet sind.

전원 케이블 및 AC 어댑터

경고! 제품을 설치할 때 현지 코드 및 적절한 굵기의 코드와 플러그를 포함한 안전 요구 사항을 준수하여 제공되거나 지정된 연결 혹은 구매 케이블, 전원 케이블 및 AC 어댑터를 사용하십시오.

다른 케이블이나 어댑터를 사용하면 오작동이나 화재가 발생할 수 있습니다. 전기 용품 안전법은 UL 또는 CSA 인증 케이블 (코드에 UL / CSA가 표시된 케이블)을 Supermicro 가 지정한 제품 이외의 전기 장치에 사용하는 것을 금지합니다.

Stroomkabel en AC-Adapter

Waarschuwing! Bij het aansluiten van het Product uitsluitend gebruik maken van de geleverde Kabels of een andere geschikte aan te schaffen Aansluitmethode, deze moet altijd voldoen aan de lokale voorschriften en veiligheidsnormen, inclusief de juiste kabeldikte en stekker. Het gebruik van niet geschikte Kabels en/of Adapters kan een storing of brand veroorzaken. Wetgeving voor Elektrische apparatuur en Materiaalveiligheid verbied het gebruik van UL of CSA -gecertificeerde Kabels (met UL/CSA in de code) voor elke andere toepassing dan de door Supermicro hiervoor beoogde Producten.

Appendix C

CPU-Based RAID for NVMe

Intel® Virtual RAID on CPU (Intel VROC) is an enterprise RAID solution for NVMe SSDs directly attached to Intel Xeon Scalable processors. Intel Volume Management Device (VMD) is an integrated controller inside the CPU PCIe root complex.

- A single processor supports up to 12 NVMe SSDs and up to 6 RAID arrays.
- A dual processor system supports up to 24 NVMe SSDs and 12 RAID arrays.

Strip sizes are 4K, 8K, 16K, 32K, 64K, 128K.

Requirements and Restrictions

- Intel VROC is only available when the system is configured for UEFI boot mode.
- To enable the `mdadm` command and support for RSTe, install the patch from
 - Linux: <https://downloadcenter.intel.com/download/28158/Intel-Virtual-RAID-on-CPU-Intel-VROC-and-Intel-Rapid-Storage-Technology-enterprise-Intel-RSTe-Driver-for-Linux->
 - Windows: <https://downloadcenter.intel.com/download/28108/Intel-Virtual-RAID-on-CPU-Intel-VROC-and-Intel-Rapid-Storage-Technology-enterprise-Intel-RSTe-Driver-for-Windows->
- To enable Intel VROC, a hardware key must be inserted on the motherboard, and the appropriate processor's Virtual Management Devices must be enabled in the BIOS setup.
- It is possible to enable Intel VROC without a hardware key installed, but only RAID0 will be enabled.
- Intel VROC is not compatible with secure boot. This feature must be disabled.
- When creating bootable OS RAID1 devices, you must have both devices on the same CPU, and a VMD on that CPU.
- Spanning drives when creating RAID devices is not recommended to due to performance issues, even though it is supported.

Supported SSDs and Operating Systems

To see the latest support information: <https://www.intel.com/content/www/us/en/support/articles/000030310/memory-and-storage/ssd-software.html>

Additional Information

Additional information is available on the product page for the Supermicro add-on card and the linked manuals.

www.supermicro.com/products/accessories/addon/AOC-VROCxxxMOD.cfm

www.supermicro.com/manuals/other/AOC-VROCxxxMOD_Windows.pdf

C.1 Hardware Key

The Intel VROC hardware key is a license key that detects the Intel VROC SKU and activates the function accordingly. The key must be plugged into the Supermicro motherboard (connector JRK1). The key options are:

Intel® VROC Keys			
VROC Package	Description	Part Number	Intel MM Number
Standard	RAID 0, 1, 10 Supports 3rd party SSDs	AOC-VROCSTNMOD	951605
Premium	RAID 0, 1, 5, 10 Supports 3rd party SSDs	AOC-VROCPREMOD	951606
Intel SSD only	RAID 0, 1, 5, 10 Supports Intel SSDs only	AOC-VROCINTMOD	956822

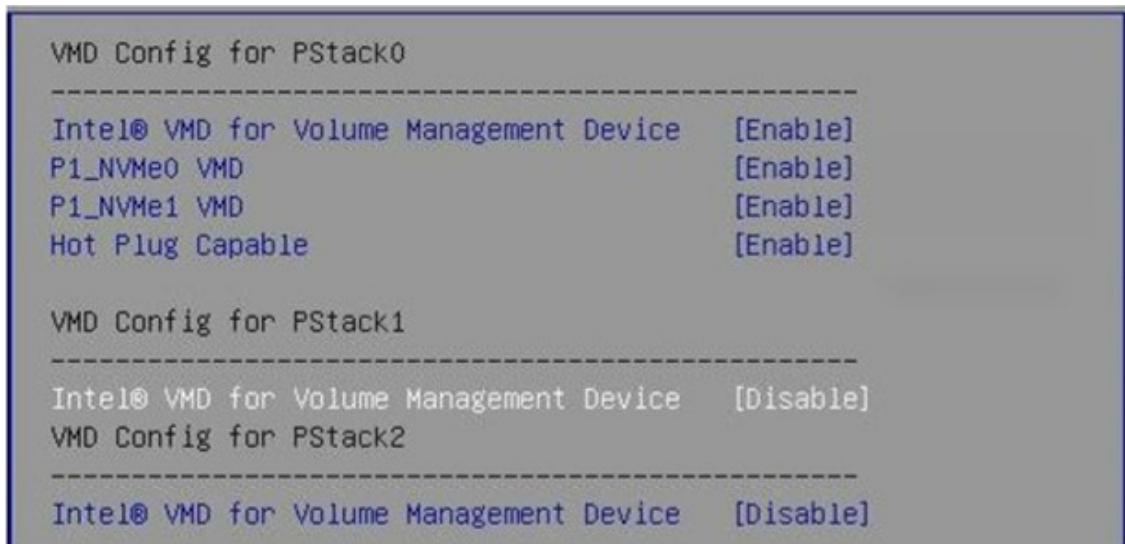

Figure C-1. Intel® VROC RAID Key and Motherboard Connector JRK1

C.2 Enabling NVMe RAID

RAID for NVMe SSDs must be enabled through the UEFI BIOS.

1. Install the patch as described in the Restrictions and Requirements section on a previous page.
2. Reboot the server and press [DEL] key to enter BIOS.
3. Switch to **Advanced > Chipset Configuration > North Bridge > IIO Configuration > Intel® VMD Technology > Intel® VMD for Volume Management Device on Socket for CPU1 & CPU2.**
4. Select each VMD on the CPU and enable VMD mode for the NVMe device.



```
VMD Config for PStack0
-----
Intel® VMD for Volume Management Device  [Enable]
P1_NVMe0 VMD                             [Enable]
P1_NVMe1 VMD                             [Enable]
Hot Plug Capable                         [Enable]

VMD Config for PStack1
-----
Intel® VMD for Volume Management Device  [Disable]
VMD Config for PStack2
-----
Intel® VMD for Volume Management Device  [Disable]
```

Figure C-2. BIOS, Enabling VMD Mode

5. Select the desired PStack# to Enable or Disable the corresponding Intel VMD controller

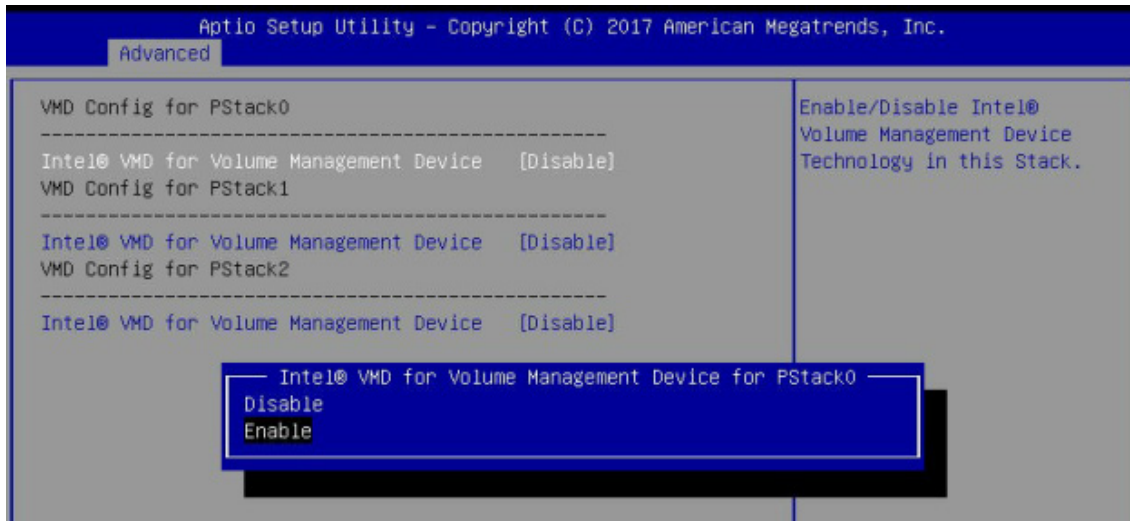

Figure C-3. BIOS, Enabling VMD for Pstack0

6. Select the desired PCIe slot to Enable or Disable Intel VMD functionality according to the current hardware configuration being used. Hot Plug Capability can also be Enabled or Disabled

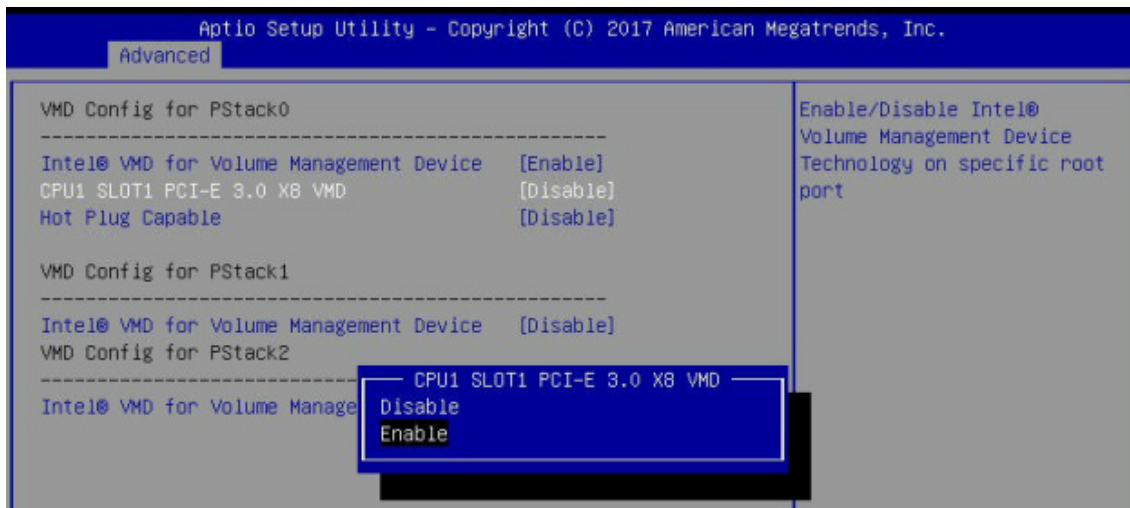

Figure C-4. BIOS, Enabling VMD Functionality per Slot

- Repeat steps 5-6 for each PStack# on each CPU to be enabled or disabled. In this example, we enabled CPU1 Slot1 (Figure C-5) and CPU2 Slot5 (Figure C-6) (our 4x U.2 form factor SSDs), as well as CPU1 M.2 C-1 and CPU1 M2. C-2 (our 2x M.2 form factor SSDs).

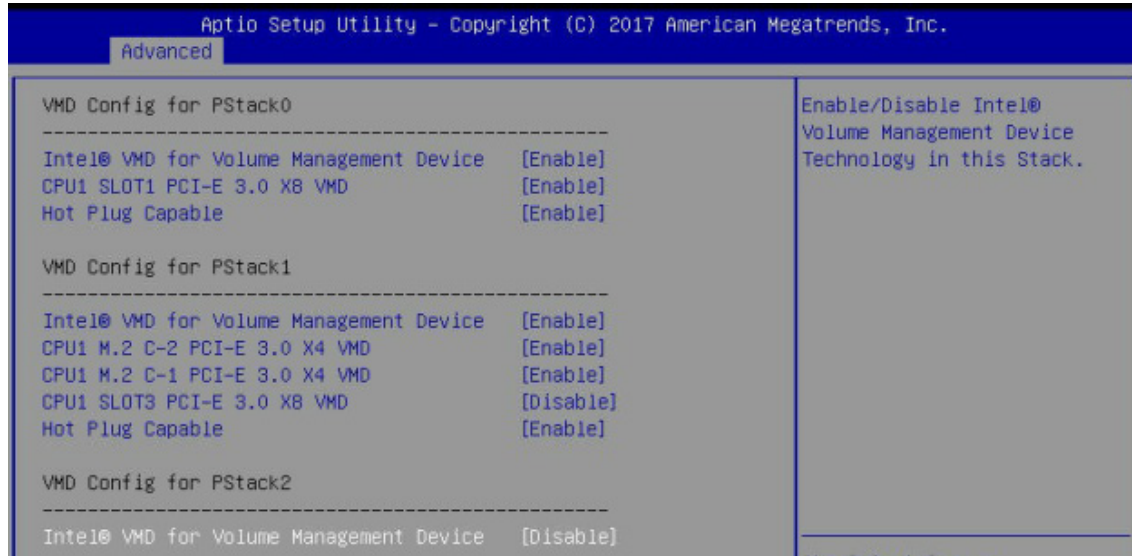

Figure C-5. BIOS, Enabling CPU1 Example

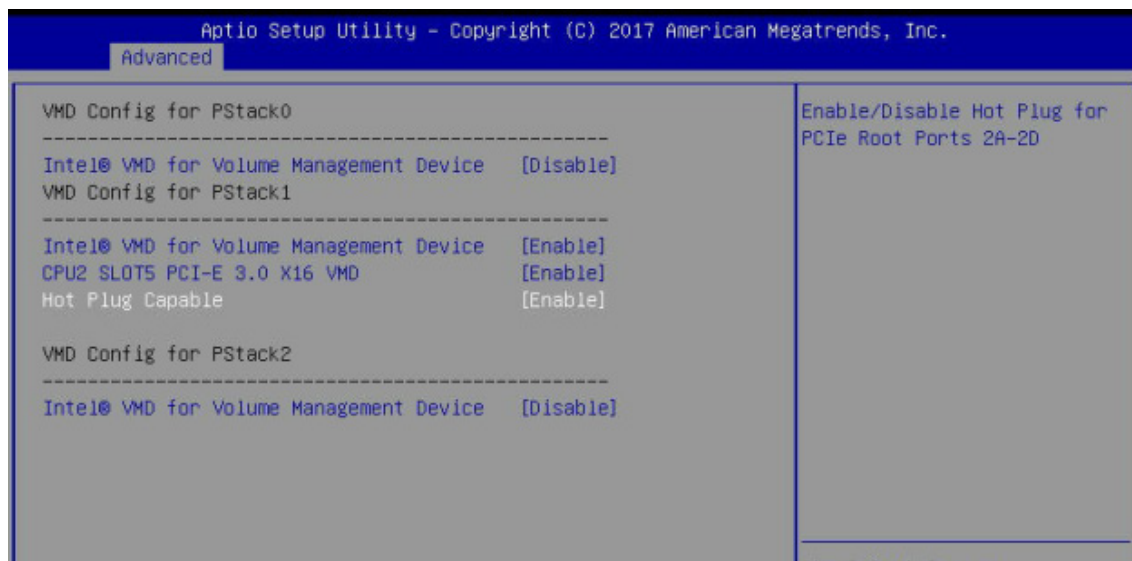

Figure C-6. BIOS, Enabling CPU2 Example

8. Press [F4] to save the configuration and reboot the system and press [DEL] to enter BIOS.

Note: Disabling the VMD controller without first deleting the associated existing RAID volume can lead to unexpected behavior. This action is strongly not recommended.

Note: The effects of physically changing or swapping a CPU on the VMD controller enablement has not yet been thoroughly tested or documented.

9. Switch to **Advanced > Intel(R) Virtual RAID on CPU > All Intel VMD Controllers > Create RAID Volume**.
10. Set **Name**.
11. Set **RAID Level**.
12. If cross-controller RAID is required, select **Enable RAID spanned over VMD Controller**.

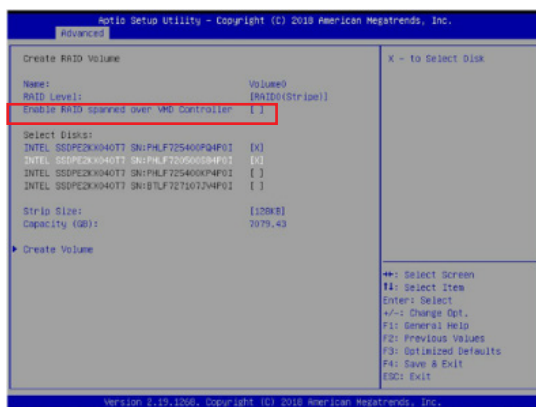

Figure C-7. Created Volume *without* enabling RAID spanned over VMD controller

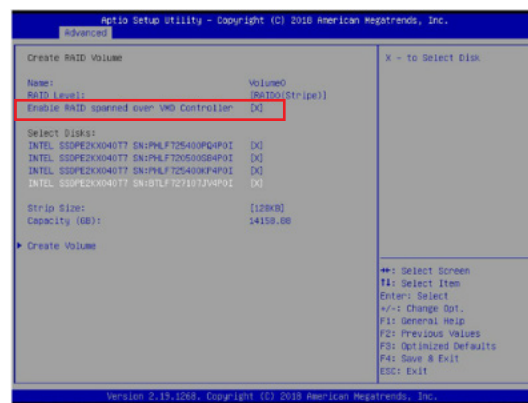

Figure C-8. Created Volume *with* enabling RAID spanned over VMD controller

13. Select specific disks for RAID with an [X].
 - RAID0: Select at least two [2 - 24] disks
 - RAID1: Select only two disks
 - RAID5: Select at least three [3 - 24] disks
 - RAID10: Select only four disks
14. Select **Strip Size** (Default 64KB).
15. Select **Create Volume**.
16. If another RAID is needed, start again at step 9.
17. Press [F4] to save and reboot.

C.3 Status Indications

An LED indicator on the drive carrier shows the RAID status of the drive.

Drive Carrier Status LED Indicator	
Status	State (red)
Normal function	Off
Locating	4 Hz blink
Fault	Solid on
Rebuilding	1 Hz Blink

IBPI SFF 8489 Defined Status LED States

C.4 Hot Swap Drives

Intel VMD enables hot-plug and hot-unplug for NVMe SSDs, whether from Intel or other manufacturers. Under vSphere ESXi, several steps are necessary to avoid potential stability issues. See the information at link [1] below.

Hot-unplug

1. Prevent devices from being re-detected during rescan:

```
esxcli storage core claiming autoclaim --enabled=false
```

2. Unmount the VMFS volumes on the device. Check [2] for details.
3. Detach the device. Check [3] for details.
4. Physically remove the device.

Hot-plug

- Physically install the device.

ESXi will automatically discover NVMe SSDs, but a manual scan may be required in some cases.

Related Information Links

[1] <https://kb.vmware.com/s/article/2151404>

[2] <https://docs.vmware.com/en/VMware-vSphere/6.5/com.vmware.vsphere.storage.doc/GUID-1B56EF97-F60E-4F21-82A7-8F2A7294604D.html>

[3] <https://docs.vmware.com/en/VMware-vSphere/6.5/com.vmware.vsphere.storage.doc/GUID-F2E75F67-740B-4406-9F0C-A2D99A698F2A.html>

Appendix D

Specifications and Compliance

Processors

Intel Xeon 3rd Gen Scalable in a P4 LGA4189 type socket, with up to 38 cores and a thermal design power (TDP) of up to 270W

Chipset

Intel C621A

Memory

Sixteen slots for up to 2TB of 3DS LRDIMM/LRDIMM/3DS RDIMM/RDIMM/ DDR4 ECC memory with speeds of 3200/2933/2666MHz; DIMM size up to 128G at 1.2V

BIOS

256Mb SPI Flash EEPROM with AMI BIOS

Motherboard

B12DPT-6

Chassis

MCP-680-41001-0N; (WxHxD) 1.75 x 6.5 x 23.5 in. (44.5 x 165 x 597 mm)

Storage Drives

SBI-420P-1C2N: Two hot-swap 2.5" SAS or NVMe

SBI-420P-1T3N: Two hot-swap 2.5" SATA or NVMe, and one hot-swap 2.5" SATA

One M.2 SSD; an optional add-on module can provide four additional M.2 SSDs

LAN Connections

Two 25GbE onboard; an optional mezzanine card can provide two additional 25GbE, EDR, HDR, or OPA

Operating Environment

Operating Temperature: 10° to 35° C (50° to 95° F)

Non-operating Temperature: -40° to 70° C (-40° to 158° F)

Operating Relative Humidity: 8% to 90% (non-condensing)

Non-operating Relative Humidity: 5% to 95% (non-condensing)

Regulatory Compliance

FCC, ICES, CE, VCCI, RCM, NRTL, CB

Applied Directives, Standards

EMC/EMI: 2014/30/EU (EMC Directive)

FCC Part 15

ICES-003

VCCI 32-1

AS/NZS CISPR 32

EN55032

EN55035

CISPR 24

EN 61000-3-2

EN 61000-3-3

EN 61000-4-2

EN 61000-4-3

EN 61000-4-4

EN 61000-4-5

EN 61000-4-6

EN 61000-4-8

EN 61000-4-11

Green Environment:

2011/65/EU (RoHS Directive)

EC 1907/2006 (REACH)

2012/19/EU (WEEE Directive)

Product Safety: 2014/35/EU (LVD Directive)

UL/CSA 60950-1, 62368-1 (USA and Canada)

IEC/EN 60950-1, 62368-1

Perchlorate Warning

California Best Management Practices Regulations for Perchlorate Materials: This Perchlorate warning applies only to products containing CR (Manganese Dioxide) Lithium coin cells. "Perchlorate Material-special handling may apply. See www.dtsc.ca.gov/hazardouswaste/perchlorate"

この装置は、クラスA機器です。この装置を住宅環境で使用すると電波妨害を引き起こすことがあります。この場合には使用者が適切な対策を講ずるよう要求されることがあります。

VCCI – A

General Data Center Environmental Specifications

Particulate contamination specifications

Air filtration: Data centers must be kept clean to Class 8 of ISO 14644-1 (ISO 2015). The air entering the data center should be filtered with a MERV 11 filter or better. The air within the data center should be continuously filtered with a MERV 8 filter or better.

Conductive dust: Air should be free fo conductive dust, zinc whiskers, or other conductive particles.

Corrosive dust: Air should be free of corrosive dust.

Gaseous* contamination specifications

Copper coupon corrosion rate: <300 Å/month per class G1 as defined by ANSI.ISA71.04-2013, reference by ASHRAE TC 9.9

Silver coupon corrosion rate: <200 Å/month per class G1 as defined by ANSI.ISA71.04-2013, reference by ASHRAE TC 9.9

*If testing with silver or copper coupons results in values less that 200 Å/month or 300 Å/month, respectively, then operating up to 70% relative humidity (RH) is acceptable. If the testing shows corrosion levels exceed these limits, then catalyst-type pollutants are probably present and RH should be driven to 50% or lower.