

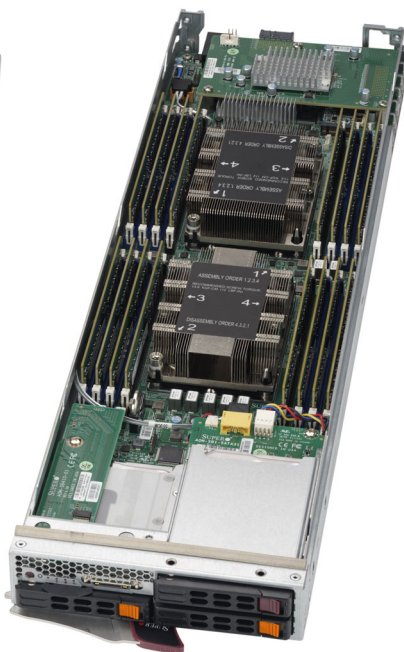

SBI-4129P-T3N SBI-4129P-C2N SuperBlade Module



SBI-4129P-C2N



SBI-4129P-T3N

User's Manual

Revision 1.0e

The information in this User's Manual has been carefully reviewed and is believed to be accurate. The vendor assumes no responsibility for any inaccuracies that may be contained in this document, and makes no commitment to update or to keep current the information in this manual, or to notify any person or organization of the updates. **Please Note: For the most up-to-date version of this manual, please see our website at www.supermicro.com.**

Super Micro Computer, Inc. ("Supermicro") reserves the right to make changes to the product described in this manual at any time and without notice. This product, including software and documentation, is the property of Supermicro and/or its licensors, and is supplied only under a license. Any use or reproduction of this product is not allowed, except as expressly permitted by the terms of said license.

IN NO EVENT WILL Super Micro Computer, Inc. BE LIABLE FOR DIRECT, INDIRECT, SPECIAL, INCIDENTAL, SPECULATIVE OR CONSEQUENTIAL DAMAGES ARISING FROM THE USE OR INABILITY TO USE THIS PRODUCT OR DOCUMENTATION, EVEN IF ADVISED OF THE POSSIBILITY OF SUCH DAMAGES. IN PARTICULAR, SUPER MICRO COMPUTER, INC. SHALL NOT HAVE LIABILITY FOR ANY HARDWARE, SOFTWARE, OR DATA STORED OR USED WITH THE PRODUCT, INCLUDING THE COSTS OF REPAIRING, REPLACING, INTEGRATING, INSTALLING OR RECOVERING SUCH HARDWARE, SOFTWARE, OR DATA.

Any disputes arising between manufacturer and customer shall be governed by the laws of Santa Clara County in the State of California, USA. The State of California, County of Santa Clara shall be the exclusive venue for the resolution of any such disputes. Supermicro's total liability for all claims will not exceed the price paid for the hardware product.

FCC Statement: This equipment has been tested and found to comply with the limits for a Class A digital device pursuant to Part 15 of the FCC Rules. These limits are designed to provide reasonable protection against harmful interference when the equipment is operated in an industrial environment. This equipment generates, uses, and can radiate radio frequency energy and, if not installed and used in accordance with the manufacturer's instruction manual, may cause harmful interference with radio communications. Operation of this equipment in a residential area is likely to cause harmful interference, in which case you will be required to correct the interference at your own expense.

California Best Management Practices Regulations for Perchlorate Materials: This Perchlorate warning applies only to products containing CR (Manganese Dioxide) Lithium coin cells. "Perchlorate Material-special handling may apply. See www.dtsc.ca.gov/hazardouswaste/perchlorate".



WARNING: This product can expose you to chemicals including lead, known to the State of California to cause cancer and birth defects or other reproductive harm. For more information, go to www.P65Warnings.ca.gov.

Manual Revision 1.0e

Release Date: June 26, 2023

Unless you request and receive written permission from Super Micro Computer, Inc., you may not copy any part of this document. Information in this document is subject to change without notice. Other products and companies referred to herein are trademarks or registered trademarks of their respective companies or mark holders.

Copyright © 2023 by Super Micro Computer, Inc.
All rights reserved.

Printed in the United States of America

Preface

About this Manual

This manual is written for professional system integrators, Information Technology professionals, service personnel and technicians. It provides information for the installation and use of the Supermicro SuperBlade[®] system's SBI-4129P-T3N/C2N SuperBlade module. Installation and maintenance should be performed by experienced professionals only.

Manual Organization

Chapter 1: Introduction

The first chapter provides a checklist of the main components included with SBI-4129P-T3N/C2N SuperBlade module and describes their main features.

Chapter 2: System Safety

You should familiarize yourself with this chapter for a general overview of safety precautions that should be followed when installing and servicing SBI-4129P-T3N/C2N SuperBlade module.

Chapter 3: Setup and Installation

Refer to this chapter for details on installing the SBI-4129P-T3N/C2N SuperBlade module into the SuperBlade chassis. Other sections cover the installation and placement of memory modules and the installation of hard disk drives into the blade module.

Chapter 4: Blade Module Features

This chapter covers features and component information about SBI-4129P-T3N/C2N SuperBlade module. Included here are descriptions and information for mainboard components, connectors, LEDs and other features of the blade module.

Chapter 5: BIOS

BIOS setup is covered in this chapter for SBI-4129P-T3N/C2N SuperBlade module.

Appendix A: BIOS POST Codes

BIOS POST Codes for SBI-4129P-T3N/C2N SuperBlade module are explained in this appendix.

Secure Data Deletion

A secure data deletion tool designed to fully erase all data from storage devices can be found on our website: https://www.supermicro.com/about/policies/disclaimer.cfm?url=/wftp/utility/Log9_Secure_Data_Deletion_Utility/

Table of Contents

Chapter 1

Introduction	1-1
1-1 Overview	1-1
1-2 Product Checklist of Typical Components.....	1-1
1-3 Blade Module Features	1-2
Processors	1-2
Memory	1-2
Storage	1-3
RAID	1-3
Enclosure Requirements.....	1-3
Density	1-4
BMC Password	1-4
1-4 Contacting Supermicro	1-5

Chapter 2

Standardized Warning Statements	2-1
2-1 About Standardized Warning Statements	2-1
Warning Definition	2-1
Installation Instructions	2-3
Circuit Breaker	2-4
Power Disconnection Warning	2-5
Equipment Installation.....	2-6
Restricted Area	2-7
Battery Handling	2-9
Redundant Power Supplies	2-10
Backplane Voltage	2-11
Comply with Local and National Electrical Codes.....	2-12
Product Disposal.....	2-14
Hot Swap Fan Warning	2-15
Power Cable and AC Adapter	2-16

Chapter 3

Setup and Installation	3-1
3-1 Overview	3-1
3-2 Installing Blade Modules	3-1
Powering Up a Blade Unit.....	3-1

Powering Down a Blade Unit	3-1
Removing a Blade Unit from the Enclosure	3-2
Removing/Replacing the Blade Cover	3-2
Installing a Blade Unit into the Enclosure	3-2
3-3 Processor Installation	3-4
Overview of the Processor Socket Assembly	3-5
Overview of the Processor Heatsink Module (PHM).....	3-6
Attaching the Processor to the Narrow Processor Clip to Create the Processor Package Assembly	3-7
Attaching the Processor Package Assembly to the Heatsink to Form the Processor Heatsink Module (PHM).....	3-8
Preparing the CPU Socket for Installation	3-10
Removing the Dust Cover from the CPU Socket.....	3-10
Removing the Processor Heatsink Module (PHM) from the Motherboard ... 3-12	
3-4 On-board Battery Installation.....	3-13
3-5 Memory Installation.....	3-13
Populating Memory Slots	3-13
DIMM Installation	3-17
3-6 Hard Disk Drive Installation	3-18
3-7 Installing a Rear Daughter Card	3-19
3-8 Installing the Operating System.....	3-21
Installing with an External USB CD-ROM Drive.....	3-21
Installing via PXE Boot.....	3-21
Installing via Virtual Media (Drive Redirection)	3-21
3-9 Management Software	3-22
3-10 Configuring and Setting up RAID	3-22

Chapter 4

Blade Module Features.....	4-1
4-1 Control Panel	4-2
Power Button	4-3
KVM Connector.....	4-3
4-2 Mainboard.....	4-4
CMOS Clear.....	4-6
Jumper Settings	4-6
4-3 Blade Unit Components	4-8
Memory Support	4-8
Hard Disk Drives	4-8

Chapter 5

BIOS	5-1
5-1 Introduction.....	5-1
System BIOS	5-1
How To Change the Configuration Data	5-1
Starting the Setup Utility	5-1
5-2 BIOS Updates.....	5-2
Flashing BIOS.....	5-2
5-3 Running Setup	5-2
5-4 Main BIOS Setup.....	5-3
5-5 Advanced Setup	5-5
5-6 Event Logs Setup.....	5-19
5-7 IPMI Setup.....	5-21
5-8 Security	5-23
5-9 Boot	5-25
5-10 Save & Exit.....	5-27

Appendix A

Updating BIOS Using KVM Console	A-1
----------------------------------------------	-----

Chapter 1

Introduction

1-1 Overview

This user's manual covers the SBI-4129P-T3N/C2N blade module. This blade module is a compact self-contained server that connects into a pre-cabled enclosure that provides power, cooling, management and networking functions. One enclosure for the SBI-4129P-T3N/C2N blade module can hold up to 20 blade units in the SBI-820C-822 model enclosure (8x2200W power supplies required for full enclosure capacity).

In this manual, "blade system" refers to the entire system (including the enclosure and blades units), "blade" or "blade unit" refers to a single blade module, "Node" refers to a single node in each blade module and "blade enclosure" is the chassis that the blades, power supplies and modules are housed within.

Please refer to our web site for information on operating systems that have been certified for use with the SuperBlade (www.supermicro.com/products/superblade/).

Note: For your system to work properly, please follow the links below to download all necessary drivers/utilities and the user's manual for your server.

- Supermicro product manuals: <http://www.supermicro.com/support/manuals/>
- Product drivers and utilities: <ftp://ftp.supermicro.com>
- Product safety information: http://www.supermicro.com/about/policies/safety_information.cfm
- If you have any questions, please contact our support team at: support@supermicro.com

Note: A complete list of safety warnings is provided on the Supermicro web site at http://www.supermicro.com/about/policies/safety_information.cfm.

1-2 Product Checklist of Typical Components

Your blade module ships with its B11DPT mainboard already installed in its chassis. Memory, hard disk drives and the CPU must all be installed by the user after shipment. See [Chapter 3: "Setup and Installation" on page 3-1](#) for details on installation of these components.

The blade module's serverboard includes an InfiniBand chip (one per node) for your blade module, which allows you to use InfiniBand communication for your blade module.

Typical support modules for systems with the SBI-4129P-T3N/C2N blade module when mounted in an 8U enclosure system include the following:

- MBM-CMM-001 or MBM-CMM-FIO CMM Module (1)
- MBM-XEM-001 or MBM-XEM-002 10G switches (up to 2)
- MBM-GEM-001 or MBM-GEM-004 1G switches (up to 2)
- SBM-IBS-E3616 or SBM-OPA-C4020 100G switches (1)

1-3 Blade Module Features

Table 1-1 lists the main features of the SBI-4129P-T3N/C2N blade module. See the proceeding section for components typically included in a blade system and other optional components. Specific details for the SBI-4129P-T3N/C2N blade module are found in [Chapter 4: "Blade Module Features" on page 4-1](#).

Table 1-1. SBI-4129P-T3N/C2N SuperBlade Module Specification Features

Mainboard	B11DPT (proprietary form factor)
Processors	Two Intel™ Xeon® EP series Socket P processors for each node. Please refer to our web site for a complete listing of supported processors.
UPI Speed	UPI up to 10.4 GT/s
Chipset	One Intel C622 chip set for each node
Graphics Controller	Integrated Aspeed AST 2500 VGA Graphics chip for each node
BIOS	256 Mb SPI Flash EEPROM with AMI® BIOS for each node
Memory Capacity	Supports up to 2 TB of RDIMM/LRDIMM DDR4 2400/2666 MHz speed and 8 GB, 16 GB, 32 GB, 64 GB and 128 GB size SDRAM memory in sixteen (16) 288-pin DIMM sockets for each node. See https://www.supernmicro.com/support/resources/memory/X11_memory_config_guide.pdf for details.
Hard Drive Bays	Includes three hot-swap drive bays for 2.5" SATA/SSD/NVMe disk drives and one M.2 connector supports 80-mm M.2 SSDs.
Add-on Cards	The SBI-4129P-T3N/C2N blade module uses both AOM-SB410-01-P and the AOM-SBI-SATA31-P add-on cards.
System Weight	15 lbs (6.8 kg)
System Dimensions	1.75 x 6.5 x 23.5" (44.45 x 165.1 x 596.9 mm)

Processors

The SBI-4129P-T3N/C2N SuperBlade module supports two Socket P LBA 3647 Intel Xeon processor EP series processors grouped two per node.

Refer to the Supermicro web site for a complete listing of supported processors (<http://www.supernmicro.com/products/superblade>). Please note that you will need to check the detailed specifications of a particular blade module for a list of the CPUs it supports.

Details on installation of the processor into the SBI-4129P-T3N/C2N SuperBlade module are found in [Chapter 3: "Setup and Installation" on page 3-1](#).

Memory

Both the SBI-4129P-T3N/C2N SuperBlade module have sixteen (16) 288-pin DIMM sockets that can support up to 2 TB of RDIMM/LRDIMM DDR4 2400/2666 MHz speed, 8 GB, 16 GB, 32 GB, 64 GB and 128 GB size SDRAM 1.2V memory per node. Memory is interleaved, which requires modules of the same size and speed to be installed in groups (of two or three).

Please refer to the Supermicro web site for a list of supported memory (www.supermicro.com/products/superblade). The detailed specifications for a blade module will contain a link to a list of recommended memory sizes and manufacturers.

Details on installation of memory modules into the SBI-4129P-T3N/C2N SuperBlade module are found in [Chapter 3: "Setup and Installation" on page 3-1](#).

Storage

The SBI-4129P-T3N/C2N SuperBlade modules can have the following configurations in front-mounted easy removable carriers.

Table 1-2. SBI-4129P-T3N/C2N Storage Configurations

SBI-4129P-T3N Blade Module	SBI-4129P-C2N Blade Module
2 hot-swap 2.5" NVMe drives and 1 hot-swap 2.5" SATA3 drive	2 hot-swap 2.5" NVMe/SAS3/SATA3 drives
3 hot-swap 2.5" SATA3 drives	

Additionally, both blade modules can each have one on board PCI-E X4 M.2 connector. They both can have an additional AOM card consisting of four PCI-E X4 M.2 connectors for four additional M.2 drives.

See [Chapter 3: "Setup and Installation" on page 3-1](#) for storage installation details.

RAID

Each SBI-4129P-T3N/C2N blade module supports up to three hard drives, which may create either a RAID 0 and 1 system for the SBI-4129P-C2N, or RAID 0, 1 and 5 for the SBI-4129P-T3N blade module.

Further information on the RAID and its software can be found on our website at:

http://www.supermicro.com/manuals/other/LSI_2108_2208_SAS_MegaRAID_Configuration_Utility.pdf

Enclosure Requirements

The SBI-4129P-T3N/C2N blade module requires one of the following enclosures to run in:

- SBE-820C-822/622/422
- SBE-820J-822/622/422
- SBE-820JB-422

The SBI-4129P-T3N/C2N blade module also requires a power supply in the enclosure to run the blade module. Available SuperBlade power supplies can be found on the Supermicro website at <https://www.supermicro.com/products/SuperBlade/powersupply/>.

Density

A maximum of 20 blade modules may be installed into a single blade enclosure. Each blade enclosure is a 8U form factor, so a standard 42U rack may accommodate up to five enclosures with 100 blade modules, or the equivalent of 100 1U servers. With the inclusion of five CMM modules, ten Gigabit Ethernet switches and five InfiniBand/Omni-path switches, this would occupy up to 115U space in a conventional 1U server configuration.

BMC Password

For security, each blade unit is assigned a unique default BMC password for the ADMIN user. It can be found on a sticker on the blade service tab, and a sticker on the motherboard. The sticker also displays the BMC MAC address. For more information, refer to our website at https://www.supermicro.com/en/support/BMC_Unique_Password. The service tab and an example sticker are illustrated below.

Figure 1-1. Service Tag Location on a Blade Module

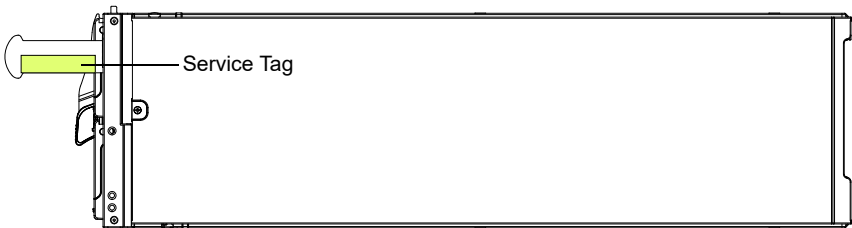

Password
Sticker



1-4 Contacting Supermicro

Headquarters

Address: Super Micro Computer, Inc.
980 Rock Ave.
San Jose, CA 95131 U.S.A.

Tel: +1 (408) 503-8000

Fax: +1 (408) 503-8008

Email: marketing@supermicro.com (General Information)
support@supermicro.com (Technical Support)

Web Site: www.supermicro.com

Europe

Address: Super Micro Computer B.V.
Het Sterrenbeeld 28, 5215 ML
's-Hertogenbosch, The Netherlands

Tel: +31 (0) 73-6400390

Fax: +31 (0) 73-6416525

Email: sales@supermicro.nl (General Information)
support@supermicro.nl (Technical Support)
rma@supermicro.nl (Customer Support)

Asia-Pacific

Address: Super Micro Computer, Inc.
3F, No. 150, Jian 1st Rd.
Zhonghe Dist., New Taipei City 23511
Taiwan (R.O.C)

Tel: +886-(2) 8226-3990

Fax: +886-(2) 8226-3992

Web Site: www.supermicro.com.tw

Technical Support:

Email: support@supermicro.com.tw

Tel: +886-(2)-8226-3990

Chapter 2

Standardized Warning Statements

2-1 About Standardized Warning Statements

The following statements are industry standard warnings, provided to warn the user of situations which have the potential for bodily injury. Should you have questions or experience difficulty, contact Supermicro's Technical Support department for assistance. Only certified technicians should attempt to install or configure components.

Read this appendix in its entirety before installing or configuring components in the Supermicro chassis

These warnings may also be found on our website at http://www.supermicro.com/about/policies/safety_information.cfm.

Warning Definition



Warning!

This warning symbol means danger. You are in a situation that could cause bodily injury. Before you work on any equipment, be aware of the hazards involved with electrical circuitry and be familiar with standard practices for preventing accidents.

警告の定義

この警告サインは危険を意味します。

人身事故につながる可能性がありますので、いずれの機器でも動作させる前に、電気回路に含まれる危険性に注意して、標準的な事故防止策に精通して下さい。

此警告符号代表危險。

您正處於可能受到嚴重傷害的工作環境中。在您使用設備開始工作之前，必須充分意識到觸電的危險，並熟練掌握防止事故發生的標準工作程序。請根據每項警告結尾的聲明號碼找到此設備的安全性警告說明的翻譯文本。

此警告符號代表危險。

您正處於可能身體可能會受損傷的工作環境中。在您使用任何設備之前，請注意觸電的危險，並且要熟悉預防事故發生的標準工作程序。請依照每一注意事項後的號碼找到相關的翻譯說明內容。

Warnung

WICHTIGE SICHERHEITSHINWEISE

Dieses Warnsymbol bedeutet Gefahr. Sie befinden sich in einer Situation, die zu Verletzungen führen kann. Machen Sie sich vor der Arbeit mit Geräten mit den Gefahren elektrischer Schaltungen und den üblichen Verfahren zur Vorbeugung vor Unfällen vertraut. Suchen Sie mit der am Ende jeder Warnung angegebenen Anweisungsnummer nach der jeweiligen Übersetzung in den übersetzten Sicherheitshinweisen, die zusammen mit diesem Gerät ausgeliefert wurden.

BEWAHREN SIE DIESE HINWEISE GUT AUF.

INSTRUCCIONES IMPORTANTES DE SEGURIDAD

Este símbolo de aviso indica peligro. Existe riesgo para su integridad física. Antes de manipular cualquier equipo, considere los riesgos de la corriente eléctrica y familiarícese con los procedimientos estándar de prevención de accidentes. Al final de cada advertencia encontrará el número que le ayudará a encontrar el texto traducido en el apartado de traducciones que acompaña a este dispositivo.

GUARDE ESTAS INSTRUCCIONES.

IMPORTANTES INFORMATIONS DE SÉCURITÉ

Ce symbole d'avertissement indique un danger. Vous vous trouvez dans une situation pouvant entraîner des blessures ou des dommages corporels. Avant de travailler sur un équipement, soyez conscient des dangers liés aux circuits électriques et familiarisez-vous avec les procédures couramment utilisées pour éviter les accidents. Pour prendre connaissance des traductions des avertissements figurant dans les consignes de sécurité traduites qui accompagnent cet appareil, référez-vous au numéro de l'instruction situé à la fin de chaque avertissement.

CONSERVEZ CES INFORMATIONS.

הצהרות הבאות הן אזהרות על פי תקני התעשייה, על מנת להזהיר את המשתמש מפני חבלה פיזית אפשרית. במידה ויש שאלות או היתקלות בבעיה כלשהי, יש ליצור קשר עם מחלקת תמיכה טכנית של סופרמיקרו. טכנאים מוסמכים בלבד רשאים להתקין או להגדיר את הרכיבים.

יש לקרוא את הנספח במלווא לפני התקנת או הגדרת הרכיבים במארזי סופרמיקרו.

تحذير! هذا الرمز يعني خطر انك في حالة يمكن أن تتسبب في اصابة جسدية .
قبل أن تعمل على أي معدات، كن على علم بالمخاطر الناجمة عن الدوائر
الكهربائية

وكن على دراية بالممارسات الوقائية لمنع وقوع أي حوادث
استخدم رقم البيان المنصوص في نهاية كل تحذير للعثور ترجمتها

안전을 위한 주의사항

경고!

이 경고 기호는 위험이 있음을 알려 줍니다. 작업자의 신체에 부상을 야기 할 수 있는 상태에 있게 됩니다. 모든 장비에 대한 작업을 수행하기 전에 전기회로와 관련된 위험 요소들을 확인하시고 사전에 사고를 방지할 수 있도록 표준 작업절차를 준수해 주시기 바랍니다.

해당 번역문을 찾기 위해 각 경고의 마지막 부분에 제공된 경고문 번호를 참조하십시오

BELANGRIJKE VEILIGHEIDSINSTRUCTIES

Dit waarschuwings symbool betekent gevaar. U verkeert in een situatie die lichamelijk letsel kan veroorzaken. Voordat u aan enige apparatuur gaat werken, dient u zich bewust te zijn van de bij een elektrische installatie betrokken risico's en dient u op de hoogte te zijn van de standaard procedures om ongelukken te voorkomen. Gebruik de nummers aan het eind van elke waarschuwing om deze te herleiden naar de desbetreffende locatie.

BEWAAR DEZE INSTRUCTIES

Installation Instructions



Warning!

Read the installation instructions before connecting the system to the power source.

設置手順書

システムを電源に接続する前に、設置手順書をお読み下さい。

警告

将此系统连接电源前，请先阅读安装说明。

警告

將系統與電源連接前，請先閱讀安裝說明。

Warnung

Vor dem Anschließen des Systems an die Stromquelle die Installationsanweisungen lesen.

¡Advertencia!

Lea las instrucciones de instalación antes de conectar el sistema a la red de alimentación.

Attention

Avant de brancher le système sur la source d'alimentation, consulter les directives d'installation.

יש לקרוא את הוראות התקנה לפני חיבור המערכת למקור מתח.

اقر إرشادات التركيب قبل توصيل النظام إلى مصدر للطاقة
시스템을 전원에 연결하기 전에 설치 안내를 읽어주십시오.

Waarschuwing

Raadpleeg de installatie-instructies voordat u het systeem op de voedingsbron aansluit.

Circuit Breaker



Warning!

This product relies on the building's installation for short-circuit (overcurrent) protection. Ensure that the protective device is rated not greater than: 250 V, 20 A.

サーキット・ブレーカー

この製品は、短絡（過電流）保護装置がある建物での設置を前提としています。

保護装置の定格が 250 V、20 A を超えないことを確認下さい。

警告

此产品的短路（过载电流）保护由建筑物的供电系统提供，确保短路保护设备的额定电流不大于 250V,20A。

警告

此產品的短路（過載電流）保護由建築物的供電系統提供，確保短路保護設備的額定電流不大於 250V,20A。

Warnung

Dieses Produkt ist darauf angewiesen, dass im Gebäude ein Kurzschluss- bzw. Überstromschutz installiert ist. Stellen Sie sicher, dass der Nennwert der Schutzvorrichtung nicht mehr als: 250 V, 20 A beträgt.

¡Advertencia!

Este equipo utiliza el sistema de protección contra cortocircuitos (o sobrecorrientes) del edificio. Asegúrese de que el dispositivo de protección no sea superior a: 250 V, 20 A.

Attention

Pour ce qui est de la protection contre les courts-circuits (surtension), ce produit dépend de l'installation électrique du local. Vérifiez que le courant nominal du dispositif de protection n'est pas supérieur à :250 V, 20 A.

מוצר זה מסתמך על הגנה המותקנת במבנים למניעת קצר חשמלי. יש לוודא כי
המכשיר המגן מפני הקצר החשמלי הוא לא יותר מ-20 A, 250 V

هذا المنتج يعتمد على معدات الحماية من الدوائر القصيرة التي تم تثبيتها في
المبنى
تأكد من أن تقييم الجهاز الوقائي ليس أكثر من: 20A, 250V

경고 !

이 제품은 전원의 단락 (과전류) 방지에 대해서 전적으로 건물의 관련 설비에 의존합니다. 보호장치의 정격이 반드시 250V(볼트), 20A(암페어)를 초과하지 않도록 해야 합니다.

Waarschuwing

Dit product is afhankelijk van de kortsluitbeveiliging (overspanning) van uw elektrische installatie. Controleer of het beveiligde apparaat niet groter gedimensioneerd is dan 250V, 20A.

Power Disconnection Warning



Warning!

The system must be disconnected from all sources of power and the power cord removed from the power supply module(s) before accessing the chassis interior to install or remove system components.

電源切斷の警告

システムコンポーネントの取り付けまたは取り外しのために、シャーシ内部にアクセスするには、

システムの電源はすべてのソースから切斷され、電源コードは電源モジュールから取り外す必要があります。

警告

在你打开机箱并安装或移除内部器件前，必须将系统完全断电，并移除电源线。

警告

在您打開機殼安裝或移除內部元件前，必須將系統完全斷電，並移除電源線。

Warnung

Das System muss von allen Quellen der Energie und vom Netzanschlusskabel getrennt sein, das von den Spg.Versorgungsteilmodulen entfernt wird, bevor es auf den Chassisinnenraum zurückgreift, um Systemsbestandteile anzubringen oder zu entfernen.

¡Advertencia!

El sistema debe ser disconnected de todas las fuentes de energía y del cable eléctrico quitado de los módulos de fuente de alimentación antes de tener acceso el interior del chasis para instalar o para quitar componentes de sistema.

Attention

Le système doit être débranché de toutes les sources de puissance ainsi que de son cordon d'alimentation secteur avant d'accéder à l'intérieur du châssis pour installer ou enlever des composants de système.

אזהרה מפני ניתוק חשמלי

!אזהרה!

יש לנתק את המערכת מכל מקורות החשמל ויש להסיר את כבל החשמלי מהספק לפני גישה לחלק הפנימי של המארז לצורך התקנת או הסרת רכיבים.

يجب فصل النظام من جميع مصادر الطاقة وإزالة سلك الكهرباء من وحدة امداد الطاقة قبل

الوصول إلى المناطق الداخلية للهيكل لتثبيت أو إزالة مكونات الجهاز

경고 !

시스템에 부품들을 장착하거나 제거하기 위해서는 채시 내부에 접근하기 전에 반드시 전원 공급장치로부터 연결되어있는 모든 전원과 전기코드를 분리해주어야 합니다.

Waarschuwing

Voordat u toegang neemt tot het binnenwerk van de behuizing voor het installeren of verwijderen van systeem onderdelen, dient u alle spanningsbronnen en alle stroomkabels aangesloten op de voeding(en) van de behuizing te verwijderen.

Equipment Installation



Warning!

Only trained and qualified personnel should be allowed to install, replace, or service this equipment.

機器の設置

トレーニングを受け認定された人だけがこの装置の設置、交換、またはサービスを許可されています。

警告

只有经过培训且具有资格的人员才能进行此设备的安装、更换和维修。

警告

只有經過受訓且具資格人員才可安裝、更換與維修此設備。

Warnung

Das Installieren, Ersetzen oder Bedienen dieser Ausrüstung sollte nur geschultem, qualifiziertem Personal gestattet werden.

¡Advertencia!

Solamente el personal calificado debe instalar, reemplazar o utilizar este equipo.

Attention

Il est vivement recommandé de confier l'installation, le remplacement et la maintenance de ces équipements à des personnels qualifiés et expérimentés.

אזהרה!

צוות מוסמך בלבד רשאי להתקין, להחליף את הציוד או לתת שירות עבור הציוד.

يجب أن يسمح فقط للموظفين المؤهلين والمدربين لتكيب واستبدال أو خدمة هذا الجهاز
경고!

훈련을 받고 공인된 기술자만이 이 장비의 설치, 교체 또는 서비스를 수행할 수 있습니다.

Waarschuwing

Deze apparatuur mag alleen worden geïnstalleerd, vervangen of hersteld door geschoold en gekwalificeerd personeel.

Restricted Area



Warning!

This unit is intended for installation in restricted access areas. A restricted access area can be accessed only through the use of a special tool, lock and key, or other means of security. (This warning does not apply to workstations).

アクセス制限区域

このユニットは、アクセス制限区域に設置されることを想定しています。

アクセス制限区域は、特別なツール、鍵と錠前、その他のセキュリティの手段を用いてのみ出入りが可能です。

警告

此部件应安装在限制进出的场所·限制进出的场所指只能通过使用特殊工具、锁和钥匙或其它安全手段进出的场所。

警告

此装置仅限安装於进出管制区域·进出管制区域係指僅能以特殊工具、鎖頭及鑰匙或其他安全方式才能進入的區域。

Warnung

Diese Einheit ist zur Installation in Bereichen mit beschränktem Zutritt vorgesehen. Der Zutritt zu derartigen Bereichen ist nur mit einem Spezialwerkzeug, Schloss und Schlüssel oder einer sonstigen Sicherheitsvorkehrung möglich.

¡Advertencia!

Esta unidad ha sido diseñada para instalación en áreas de acceso restringido. Sólo puede obtenerse acceso a una de estas áreas mediante la utilización de una herramienta especial, cerradura con llave u otro medio de seguridad.

Attention

Cet appareil doit être installée dans des zones d'accès réservés. L'accès à une zone d'accès réservé n'est possible qu'en utilisant un outil spécial, un mécanisme de verrouillage et une clé, ou tout autre moyen de sécurité.

אזור עם גישה מוגבלת

אזהרה!

יש להתקין את היחידה באזורים שיש בהם הגבלת גישה. הגישה ניתנת בעזרת כלי אבטחה בלבד (מפתח, מנעול וכד').

تم تخصيص هذه الوحدة لتركيبها في مناطق محظورة .
يمكن الوصول إلى منطقة محظورة فقط من خلال استخدام أداة خاصة،
قفل ومفتاح أو أي وسيلة أخرى للأمان

경고 !

이 장치는 접근이 제한된 구역에 설치하도록 되어있습니다. 특수도구, 잠금 장치 및 키, 또는 기타 보안 수단을 통해서만 접근 제한 구역에 들어갈 수 있습니다.

Waarschuwing

Dit apparaat is bedoeld voor installatie in gebieden met een beperkte toegang. Toegang tot dergelijke gebieden kunnen alleen verkregen worden door gebruik te maken van speciaal gereedschap, slot en sleutel of andere veiligheidsmaatregelen.

Battery Handling



Warning!

There is the danger of explosion if the battery is replaced incorrectly. Replace the battery only with the same or equivalent type recommended by the manufacturer. Dispose of used batteries according to the manufacturer's instructions.

電池の取り扱い

電池交換が正しく行われなかった場合、破裂の危険性があります。交換する電池はメーカーが推奨する型、または同等のものを使用下さい。使用済電池は製造元の指示に従って処分して下さい。

警告

電池更換不當會有爆炸危險。請只使用同類電池或制造商推荐的功能相当的電池更換原有電池。請按制造商的說明處理廢舊電池。

警告

電池更換不當會有爆炸危險。請使用製造商建議之相同或功能相當的電池更換原有電池。請按照製造商的說明指示處理廢棄舊電池。

Warnung

Bei Einsetzen einer falschen Batterie besteht Explosionsgefahr. Ersetzen Sie die Batterie nur durch den gleichen oder vom Hersteller empfohlenen Batterietyp. Entsorgen Sie die benutzten Batterien nach den Anweisungen des Herstellers.

Attention

Danger d'explosion si la pile n'est pas remplacée correctement. Ne la remplacer que par une pile de type semblable ou équivalent, recommandée par le fabricant. Jeter les piles usagées conformément aux instructions du fabricant.

¡Advertencia!

Existe peligro de explosión si la batería se reemplaza de manera incorrecta. Reemplazar la batería exclusivamente con el mismo tipo o el equivalente recomendado por el fabricante. Desechar las baterías gastadas según las instrucciones del fabricante.

אזהרה!

קיימת סכנת פיצוץ של הסוללה במידה והוחלפה בדרך לא תקינה. יש להחליף את הסוללה בסוג התואם מחברת יצרן מומלצת.

סילוק הסוללות המשומשות יש לבצע לפי הוראות היצרן.

هناك خطر من انفجار في حالة استبدال البطارية بطريقة غير صحيحة فعليك
استبدال البطارية
فقط بنفس النوع أو ما يعادلها كما أوصت به الشركة المصنعة
تخلص من البطاريات المستعملة وفقا لتعليمات الشركة الصانعة

경고!

배터리가 올바르게 교체되지 않으면 폭발의 위험이 있습니다. 기존 배터리와 동일하거나 제조사에서 권장하는 동등한 종류의 배터리로만 교체해야 합니다. 제조사의 안내에 따라 사용된 배터리를 처리하여 주십시오.

Waarschuwing

Er is ontploffingsgevaar indien de batterij verkeerd vervangen wordt. Vervang de batterij slechts met hetzelfde of een equivalent type die door de fabrikant aanbevolen wordt. Gebruikte batterijen dienen overeenkomstig fabrieksvoorschriften afgevoerd te worden.

Redundant Power Supplies



Warning!

This unit might have more than one power supply connection. All connections must be removed to de-energize the unit.

冗長電源裝置

このユニットは複数の電源装置が接続されている場合があります。

警告

此部件连接的电源可能不止一个，必须将所有电源断开才能停止给该部件供电。

警告

此裝置連接的電源可能不只一個，必須切斷所有電源才能停止對該裝置的供電。

Warnung

Dieses Gerät kann mehr als eine Stromzufuhr haben. Um sicherzustellen, dass der Einheit kein Strom zugeführt wird, müssen alle Verbindungen entfernt werden.

¡Advertencia!

Puede que esta unidad tenga más de una conexión para fuentes de alimentación. Para cortar por completo el suministro de energía, deben desconectarse todas las conexiones.

Attention

Cette unité peut avoir plus d'une connexion d'alimentation. Pour supprimer toute tension et tout courant électrique de l'unité, toutes les connexions d'alimentation doivent être débranchées.

אם קיים יותר מספק אחד

אזהרה!

ליחידה יש יותר מחיבור אחד של ספק. יש להסיר את כל החיבורים על מנת לרוקן את היחידה.

قد يكون لهذا الجهاز عدة اتصالات بوحدات امداد الطاقة.
يجب إزالة كافة الاتصالات لعزل الوحدة عن الكهرباء

경고!

이 장치에는 한 개 이상의 전원 공급 단자가 연결되어 있을 수 있습니다. 이 장치에 전원을 차단하기 위해서는 모든 연결 단자를 제거해야만 합니다.

Waarschuwing

Deze eenheid kan meer dan één stroomtoevoeraansluiting bevatten. Alle aansluitingen dienen verwijderd te worden om het apparaat stroomloos te maken

Backplane Voltage



Warning!

Hazardous voltage or energy is present on the backplane when the system is operating. Use caution when servicing.

バックプレーンの電圧

システムの稼働中は危険な電圧または電力が、バックプレーン上にかかっています。

修理するには注意ください。

警告

当系统正在进行时·背板上有很危险的电压或能量·进行维修时务必小心。

警告

當系統正在進行時·背板上有很危險的電壓或能量·進行維修時務必小心。

Warnung

Wenn das System in Betrieb ist, treten auf der Rückwandplatine gefährliche Spannungen oder Energien auf. Vorsicht bei der Wartung.

¡Advertencia!

Quando el sistema está en funcionamiento, el voltaje del plano trasero es peligroso. Tenga cuidado cuando lo revise.

Attention

Lorsque le système est en fonctionnement, des tensions électriques circulent sur le fond de panier. Prendre des précautions lors de la maintenance.

מתח בפנל האחורי

אזהרה!

קיימת סכנת מתח בפנל האחורי בזמן תפעול המערכת. יש להיזהר במהלך העבודה.

هناك خطر من التيار الكهربائي أو الطاقة الموجودة على اللوحة عندما يكون النظام يعمل كن حذرا عند خدمة هذا الجهاز

경고!

시스템이 동작 중일 때 후면판 (Backplane) 에는 위험한 전압이나 에너지가 발생 합니다. 서비스 작업 시 주의하십시오.

Waarschuwing

Een gevaarlijke spanning of energie is aanwezig op de backplane wanneer het systeem in gebruik is. Voorzichtigheid is geboden tijdens het onderhoud.

Comply with Local and National Electrical Codes



Warning!

Installation of the equipment must comply with local and national electrical codes.

地方および国の電気規格に準拠

機器の取り付けはその地方および国の電気規格に準拠する必要があります。

警告

设备安装必须符合本地与本国电气法规。

警告

設備安裝必須符合本地與本國電氣法規。

Warnung

Die Installation der Geräte muss den Sicherheitsstandards entsprechen.

¡Advertencia!

La instalación del equipo debe cumplir con las normas de electricidad locales y nacionales.

Attention

L'équipement doit être installé conformément aux normes électriques nationales et locales.

תיאום חוקי החשמל הארצי

אזהרה!

התקנת הציוד חייבת להיות תואמת לחוקי החשמל המקומיים והארציים.

تركيب المعدات الكهربائية يجب أن يمتثل للقوانين المحلية والوطنية المتعلقة
بالكهرباء

경고!

현 지역 및 국가의 전기 규정에 따라 장비를 설치해야 합니다.

Waarschuwing

Bij installatie van de apparatuur moet worden voldaan aan de lokale en nationale elektriciteitsvoorschriften.

Product Disposal



Warning!

Ultimate disposal of this product should be handled according to all national laws and regulations.

製品の廃棄

この製品を廃棄処分する場合、国の関係する全ての法律・条例に従い処理する必要があります。

警告

本产品的废弃处理应根据所有国家的法律和规章进行。

警告

本產品的廢棄處理應根據所有國家的法律和規章進行。

Warnung

Die Entsorgung dieses Produkts sollte gemäß allen Bestimmungen und Gesetzen des Landes erfolgen.

¡Advertencia!

Al deshacerse por completo de este producto debe seguir todas las leyes y reglamentos nacionales.

Attention

La mise au rebut ou le recyclage de ce produit sont généralement soumis à des lois et/ou directives de respect de l'environnement. Renseignez-vous auprès de l'organisme compétent.

סילוק המוצר

אזהרה!

סילוק סופי של מוצר זה חייב להיות בהתאם להנחיות וחוקי המדינה.

عند التخلص النهائي من هذا المنتج ينبغي التعامل معه وفقا لجميع القوانين واللوائح الوطنية

경고!

이 제품은 해당 국가의 관련 법규 및 규정에 따라 폐기되어야 합니다.

Waarschuwing

De uiteindelijke verwijdering van dit product dient te geschieden in overeenstemming met alle nationale wetten en reglementen.

Hot Swap Fan Warning



Warning!

The fans might still be turning when you remove the fan assembly from the chassis. Keep fingers, screwdrivers, and other objects away from the openings in the fan assembly's housing.

ファン・ホットスワップの警告

シャーシから冷却ファン装置を取り外した際、ファンがまだ回転している可能性があります。ファンの開口部に、指、ドライバー、およびその他のものを近づけないで下さい。

警告!

警告! 危険的可移動性零件。请务必与转动的风扇叶片保持距离。当您从机架移除风扇装置·风扇可能仍在转动。小心不要将手指、螺丝起子和其他物品太靠近风扇。

警告

危險的可移動性零件。請務必與轉動的風扇葉片保持距離。當您從機架移除風扇裝置·風扇可能仍在轉動。小心不要將手指、螺絲起子和其他物品太靠近風扇。

Warnung

Die Lüfter drehen sich u. U. noch, wenn die Lüfterbaugruppe aus dem Chassis genommen wird. Halten Sie Finger, Schraubendreher und andere Gegenstände von den Öffnungen des Lüftergehäuses entfernt.

¡Advertencia!

Los ventiladores podran dar vuelta cuando usted quite ell montaje del ventilador del chasis. Mandtenga los dedos, los destornilladores y todos los objetos lejos de las aberturas del ventilador

Attention

Il est possible que les ventilateurs soient toujours en rotation lorsque vous retirerez le bloc ventilateur du châssis. Prenez garde à ce que doigts, tournevis et autres objets soient éloignés du logement du bloc ventilateur.

אזהרה!

חלקים נעים מסוכנים. התרחק מלהבי המאוורר בפעולה כאשר מסירים את חלקי המאוורר מהמארז, יתכן והמאווררים עדיין עובדים. יש להרחיק למרחק בטוח את

تحذير! أجزاء متحركة خطيرة. ابتعد عن شفرات المروحة المتحركة. من الممكن أن المراوح لا تزال تدور عند إزالة كتلة المروحة من الهيكل يجب إبقاء الأصابع ومفكات البراغي وغيرها من الأشياء بعيدا عن الفتحات في كتلة المروحة.
경고!

새시로부터 팬 조립품을 제거할 때 팬은 여전히 회전하고 있을 수 있습니다. 팬 조립품 외관의 열려있는 부분들로부터 손가락 및 스크류드라이버, 다른 물체들이 가까이 하지 않도록 배치해 주십시오.

Waarschuwing

Het is mogelijk dat de ventilator nog draait tijdens het verwijderen van het ventilatorsamenstel uit het chassis. Houd uw vingers, schroevendraaiers en eventuele andere voorwerpen uit de buurt van de openingen in de ventilatorbehuizing.

Power Cable and AC Adapter



Warning!

When installing the product, use the provided or designated connection cables, power cables and AC adaptors. Using any other cables and adaptors could cause a malfunction or a fire. Electrical Appliance and Material Safety Law prohibits the use of UL or CSA -certified cables (that have UL/CSA shown on the code) for any other electrical devices than products designated by Supermicro only.

電源コードと AC アダプター

製品を設置する場合、提供または指定された接続ケーブル、電源コードと AC アダプターを使用下さい。他のケーブルやアダプタを使用すると故障や火災の原因になることがあります。電気用品安全法は、UL または CSA 認定のケーブル (UL/CSE マークがコードに表記) を Supermicro が指定する製品以外に使用することを禁止しています。

警告

安装此产品时,请使用本身提供的或指定的或采购的连接线,电源线和电源适配器·包含遵照当地法规和安全要求的合规的电源线尺寸和插头.使用其它线材或适配器可能会引起故障或火灾.除了 Supermicro 所指定的产品,电气用品和材料安全法律规定禁止使用未经 UL 或 CSA 认证的线材。(线材上会显示 UL/CSA 符号)。

警告

安裝此產品時，請使用本身提供的或指定的或採購的連接線，電源線和電源適配器。包含遵照當地法規和安全要求的合規的電源線尺寸和插頭。使用其它線材或適配器可能會引起故障或火災。除了 Supermicro 所指定的產品，電氣用品和材料安全法律規定禁止使用未經 UL 或 CSA 認證的線材。(線材上會顯示 UL/CSA 符號)。

Warnung

Bei der Installation des Produkts, die zur Verfügung gestellten oder benannt Anschlusskabel, Stromkabel und Netzteile. Verwendung anderer Kabel und Adapter kann zu einer Fehlfunktion oder ein Brand entstehen. Elektrische Geräte und Material Safety Law verbietet die Verwendung von UL-oder CSA-zertifizierte Kabel, UL oder CSA auf der Code für alle anderen elektrischen Geräte als Produkte von Supermicro nur bezeichnet gezeigt haben.

¡Advertencia!

Al instalar el producto, utilice los cables de conexión previstos o designados, los cables y adaptadores de CA. La utilización de otros cables y adaptadores podría ocasionar un mal funcionamiento o un incendio. Aparatos Eléctricos y la Ley de Seguridad del Material prohíbe el uso de UL o CSA cables certificados que tienen UL o CSA se muestra en el código de otros dispositivos eléctricos que los productos designados por Supermicro solamente.

Attention

Lors de l'installation du produit, utilisez les bables de connection fournis ou désigné. L'utilisation d'autres cables et adaptateurs peut provoquer un dysfonctionnement ou un incendie. Appareils électroménagers et de loi sur la sécurité Matériel interdit l'utilisation de UL ou CSA câbles certifiés qui ont UL ou CSA indiqué sur le code pour tous les autres appareils électriques que les produits désignés par Supermicro seulement.

חשמליים ומתאמי AC

!אזהרה

כאשר מתקינים את המוצר, יש להשתמש בכבלים, ספקים ומתאמים AC אשר נועדו וסופקו לשם כך. שימוש בכל כבל או מתאם אחר יכול לגרום לתקלה או קצר חשמלי. על פי חוקי שימוש במכשירי חשמל וחוקי בטחות, קיים איסור להשתמש בכבלים המוסמכים ב- UL או ב- CSA (כשאר מופיע עליהם קוד של UL/CSA) עבור כל מוצר חשמלי אחר שלא צוין על ידי סופרמיקרו בלבד.

عند تركيب الجهاز يجب استخدام كابلات التوصيل، والكابلات الكهربائية
ومحولات التيار المتردد
التي . أن استخدام أي كابلات ومحولات أخرى يتسبب في حدوث عطل أو حريق.
تم توفيرها لك مع المنتج
الأجهزة الكهربائية ومواد قانون السلامة يحظر استخدام الكابلات UL أو CSA
معتمدة من قبل
لأي أجهزة كهربائية أخرى غير المنتجات المعينة من قبل Supermicro
(التي تحمل علامة UL/CSA)

경고!

제품을 설치할 때에는 제공되거나 지정된 연결케이블과 전원케이블, AC 어댑터를 사용해야 합니다. 그 밖의 다른 케이블들이나 어댑터들은 고장 또는 화재의 원인이 될 수 있습니다. 전기용품안전법 (Electrical Appliance and Material Safety Law) 은 슈퍼마이크로에서 지정한 제품들 외에는 그 밖의 다른 전기 장치들을 위한 UL 또는 CSA 에서 인증한 케이블 (전선 위에 UL/CSA 가 표시) 들의 사용을 금지합니다.

Waarschuwing

Bij het installeren van het product, gebruik de meegeleverde of aangewezen kabels, stroomkabels en adapters. Het gebruik van andere kabels en adapters kan leiden tot een storing of een brand. Elektrisch apparaat en veiligheidsinformatiebladen wet verbiedt het gebruik van UL of CSA gecertificeerde kabels die UL of CSA die op de code voor andere elektrische apparaten dan de producten die door Supermicro alleen.

Chapter 3

Setup and Installation

3-1 Overview

This chapter covers the setup and installation of the blade module and its components.

3-2 Installing Blade Modules

Up to 20 SBI-4129P-T3N/C2N SuperBlade module may be installed into a single blade enclosure. Blade modules with Windows and Linux operating systems may be mixed together in the same blade or blade enclosure.

Powering Up a Blade Unit

Each blade unit node may be powered on and off independently from the rest of the blades and nodes installed in the same enclosure. A blade unit may be powered up in two ways:

- Press the power button on the blade unit.
- Use IPMIView, IPMITool or the web-browser based management utility to apply power using the CMM module (if you have Operator or Admin privileges on the CMM).

Powering Down a Blade Unit

A blade unit may be powered down in either of the following ways:

- Press the power button on the blade unit.
- Use IPMIView, IPMITool or the web-browser based management utility to power down (if you have Operator or Admin privileges on the CMM).

Removing a Blade Unit from the Enclosure

Although the blade system may continue to run, individual blades should always be powered down before removing them from the enclosure.

Removing a Blade Unit from the Enclosure

1. Power down the blade unit (see "[Powering Down a Blade Unit](#)" above).
2. Squeeze the handle to depress the red section then pull out the blade unit from the enclosure using the handle.

Note: Blade Modules can be Hot-Plugged from the enclosure.

Removing/Replacing the Blade Cover

The blade cover must be removed to access the mainboard when you need to install or remove processors, memory units, the On-board battery and so on.

Removing/Replacing the Blade Cover

1. Remove the blade unit from the enclosure (see "[Removing a Blade Unit from the Enclosure](#)" above).
2. Remove the single center screw holding the cover in place and push the top cover off.
3. To replace the cover, fit the six grooves in the cover into the studs in the sides of the blade, then slide the cover toward the front of the blade to lock it into place. Then replace and screw in the center screw to hold it in place.

Installing a Blade Unit into the Enclosure

Make sure the cover of the blade unit has been replaced first before installing a blade unit in the enclosure.

Installing a Blade Unit into the Enclosure

1. Slowly push the blade unit into its bay with the handles fully pulled out (see [Figure 3-1](#)).
2. When the blade stops, push the handle back into its locked position, making sure the notches in the handle catches the lip of the enclosure (see [Figure 3-3](#)).

Note: Blade Modules can be Hot-Plugged into the enclosure.

Caution: Use extreme caution when inserting a blade module into the enclosure. If the blade's power connector becomes damaged, it can damage pins on other blade bays that it is inserted into.

Figure 3-1. Inserting a Blade into the Enclosure

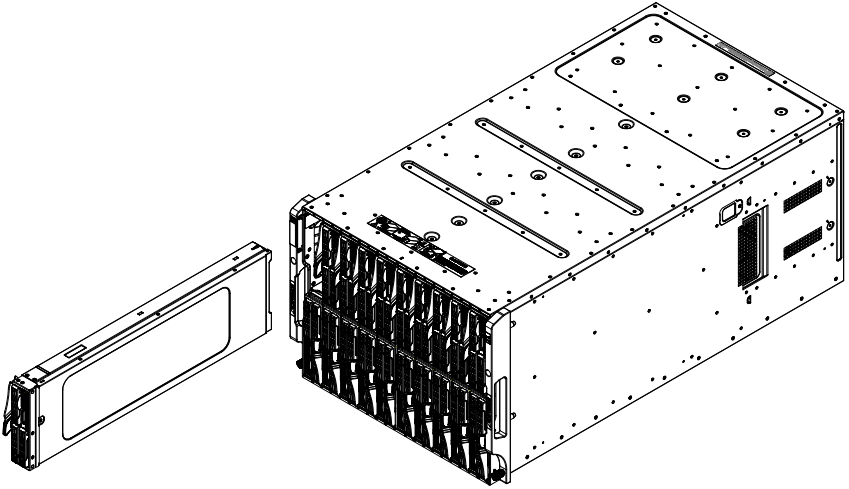

3-3 Processor Installation

One or two processors may be installed to the mainboard of each blade unit. See [Chapter 1](#) for general information on the features of the blade unit and the [Supermicro web site](#) for further details including processor, memory and operating system support.

Figure 3-2. SKX Processor

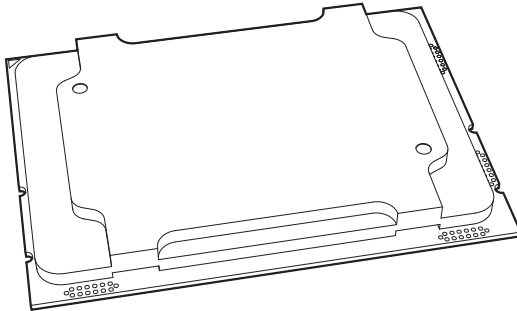

WARNING: When handling the processor package, avoid placing direct pressure on the label area of the CPU or CPU socket. Also, improper CPU installation or socket misalignment can cause serious damage to the CPU or motherboard which may result in RMA repairs. Please read and follow all instructions thoroughly before installing your CPU and heatsink.

Notes:

1. Always connect the power cord last, and always remove it before adding, removing, or changing any hardware components. Please note that the processor and heatsink should be assembled together first to form the Processor Heatsink Module (PHM), and then install the entire PHM into the CPU socket.
2. When you receive a motherboard without a processor pre-installed, make sure that the plastic CPU socket cap is in place and that none of the socket pins are bent; otherwise, contact your retailer immediately.
3. Refer to the Supermicro website for updates on CPU support.
4. Please follow the instructions given in the ESD Warning section on the first page of this chapter before handling, installing, or removing system components.
5. All graphics, drawings, and pictures shown in this manual are for illustration only. The components that came with your machine may or may not look exactly the same as those shown in this manual

Overview of the Processor Socket Assembly

The processor socket assembly contains 1) the Intel SKX processor, 2) the narrow processor clip, 3) the dust cover, and 4) the CPU socket.

1. SKX (-F) Processor

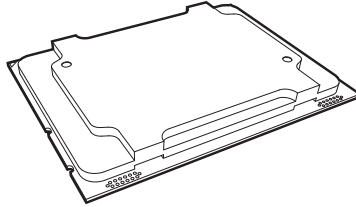

2. Narrow processor clip (the plastic processor package carrier used for the CPU)

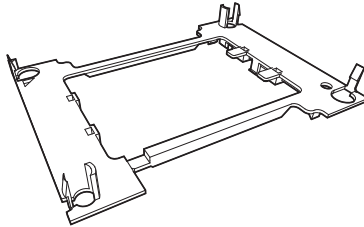

3. Dust Cover

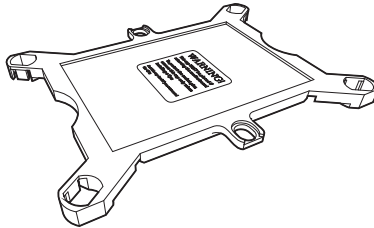

4. CPU Socket

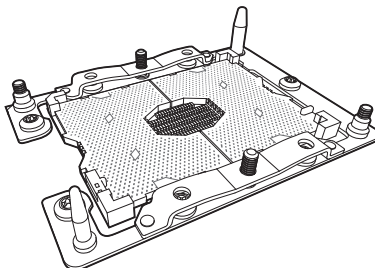

Note: Be sure to cover the CPU socket with the dust cover when the CPU is not installed.

Overview of the Processor Heatsink Module (PHM)

The Processor Heatsink Module (PHM) contains 1) a heatsink, 2) a narrow processor clip, and 3) the SKX(-F) processor.

1. Heatsink

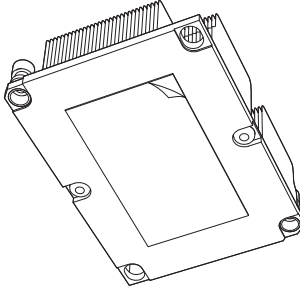

2. Narrow Processor Clip

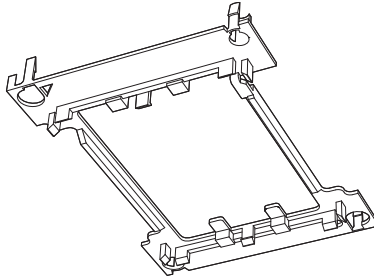

3. SKK Processor

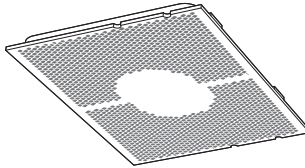

Bottom View

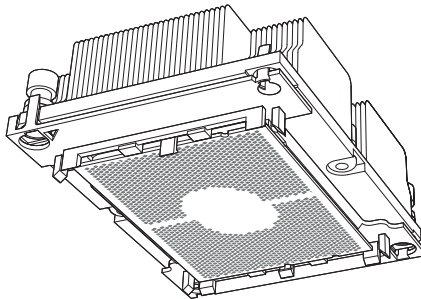

Attaching the Processor to the Narrow Processor Clip to Create the Processor Package Assembly

To properly install the CPU into the narrow processor clip, please follow the steps below.

1. Locate pin 1 (notch A), which is the triangle located on the top of the narrow processor clip. Also locate notch B and notch C on the processor clip.
2. Locate pin 1 (notch A), which is the triangle on the substrate of the CPU. Also, locate notch B and notch C on the CPU as shown below.
3. Align pin 1 (the triangle on the substrate) of the CPU with pin 1 (the triangle) of the narrow processor clip. Once they are aligned, carefully insert the CPU into the processor clip by sliding notch B of the CPU into notch B of the processor clip, and sliding notch C of the CPU into notch C of the processor clip.
4. Examine all corners of the CPU to ensure that it is properly seated on the processor clip. Once the CPU is securely attached to the processor clip, the processor package assembly is created.

Note: Please exercise extreme caution when handling the CPU. Do not touch the CPU LGA-lands to avoid damaging the LGA-lands or the CPU. Be sure to wear ESD gloves when handling components.

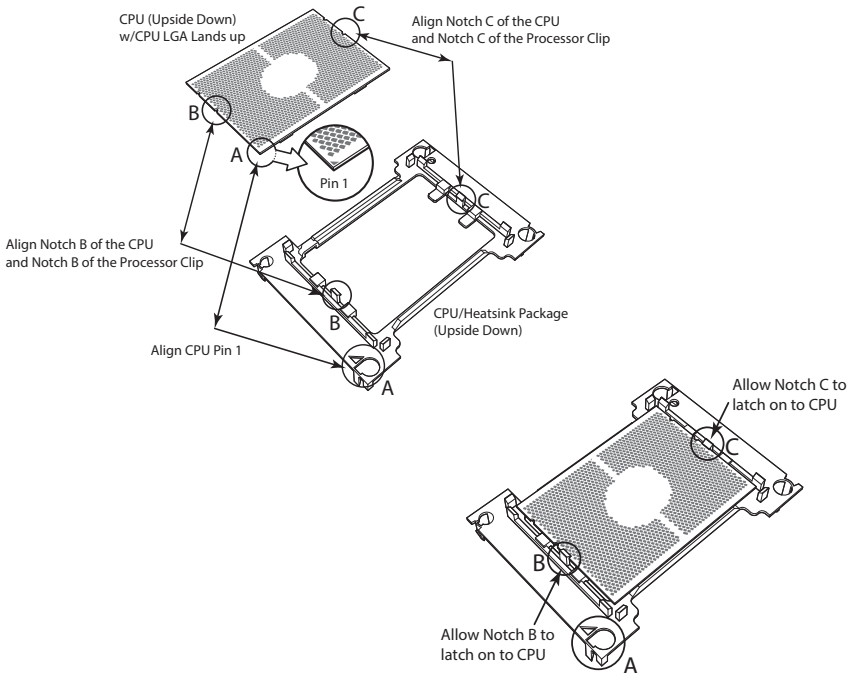

Attaching the Processor Package Assembly to the Heatsink to Form the Processor Heatsink Module (PHM)

After you have made a processor package assembly by following the instructions on the previous page, please follow the steps below to mount the processor package assembly onto the heatsink to create the Processor Heatsink Module (PHM).

1. Locate "1" on the heatsink label and the triangular corner next to it on the heatsink. With your index finger pressing against the screw at this triangular corner, carefully hold and turn the heatsink upside down with the thermal-grease side facing up. Remove the protective thermal film if present, and apply the proper amount of the thermal grease as needed. (Skip this step if you have a new heatsink because the necessary thermal grease is pre-applied in the factory.)
2. Holding the processor package assembly at the center edge, turn it upside down. With the thermal-grease side facing up, locate the hollow triangle located at the corner of the processor carrier assembly ("a" in the graphic). Note a larger hole and plastic mounting clicks located next to the hollow triangle. Also locate another set of mounting clicks and a larger hole at the diagonal corner of the same (reverse) side of the processor carrier assembly ("b" in the graphic).
3. With the back of heatsink and the reverse side of the processor package assembly facing up, align the triangular corner on the heatsink ("A" in the graphic) against the mounting clips next to the hollow triangle ("a") on the processor package assembly.
4. Also align the triangular corner ("B") at the diagonal side of the heatsink with the corresponding clips on the processor package assembly ("b").
5. Once the mounting clips on the processor package assembly are properly aligned with the corresponding holes on the back of heatsink, securely attach the heatsink to the processor package assembly by snapping the mounting clips at the proper places on the heatsink to create the processor heatsink module (PHM).

Non-Fabric CPU and Processor Clip
(Upside Down)

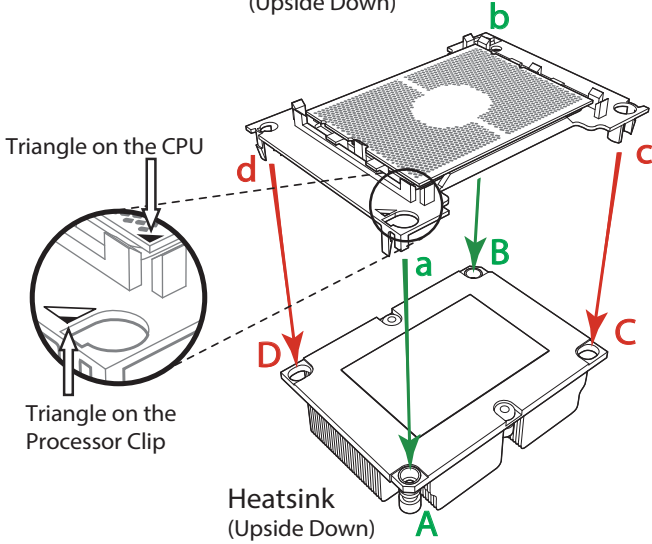

On Locations of (C, D), the notches
snap onto the heat sink's
mounting holes

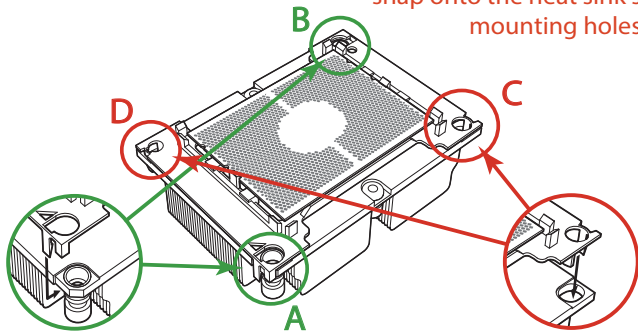

On Locations (A, B), the notches
snap onto the heatsink's sides

Make sure Mounting
Notches snap into place

Preparing the CPU Socket for Installation

This motherboard comes with the CPU socket pre-assembled in the factory. The CPU socket contains 1) a dust cover, 2) a socket bracket, 3) the CPU (P0) socket, and 4) a back plate. These components are pre-installed on the motherboard before shipping.

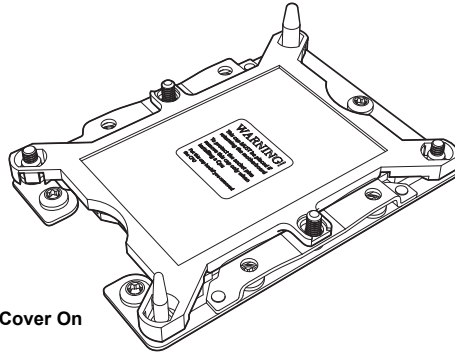

CPU Socket w/Dust Cover On

Removing the Dust Cover from the CPU Socket

Remove the dust cover from the CPU socket, exposing the SKX socket and socket pins as shown on the illustration below.

Note: Do not touch the socket pins to avoid damaging them, causing the CPU to malfunction.

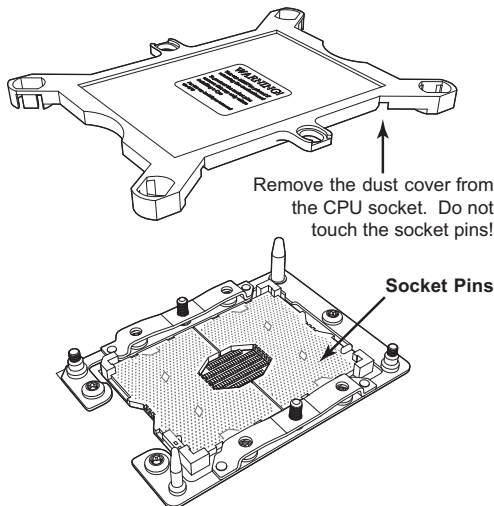

Installing the Processor Heatsink Module (PHM)

Once you have assembled the processor heatsink module (PHM) by following the instructions listed on page 29 or page 30, you are ready to install the processor heatsink module (PHM) into the CPU socket on the motherboard. To install the PHM into the CPU socket, follow the instructions below.

1. Locate the triangle (pin 1) on the CPU socket, and locate the triangle (pin 1) at the corner of the PHM that is closest to "1." (If you have difficulty locating pin 1 of the PHM, turn the PHM upside down. With the LGA-lands side facing up, you will note the hollow triangle located next to a screw at the corner. Turn the PHM right side up, and you will see a triangle marked on the processor clip at the same corner of hollow triangle.)
2. Carefully align pin 1 (the triangle) on the the PHM against pin 1 (the triangle) on the CPU socket.
3. Once they are properly aligned, insert the two diagonal oval holes on the heatsink into the guiding posts.
4. Using a T30 Torx-bit screwdriver, install four screws into the mounting holes on the socket to securely attach the PHM onto the motherboard starting with the screw marked "1" (in the sequence of 1, 2, 3, and 4).

Note: Do not use excessive force when tightening the screws to avoid damaging the LGA-lands and the processor.

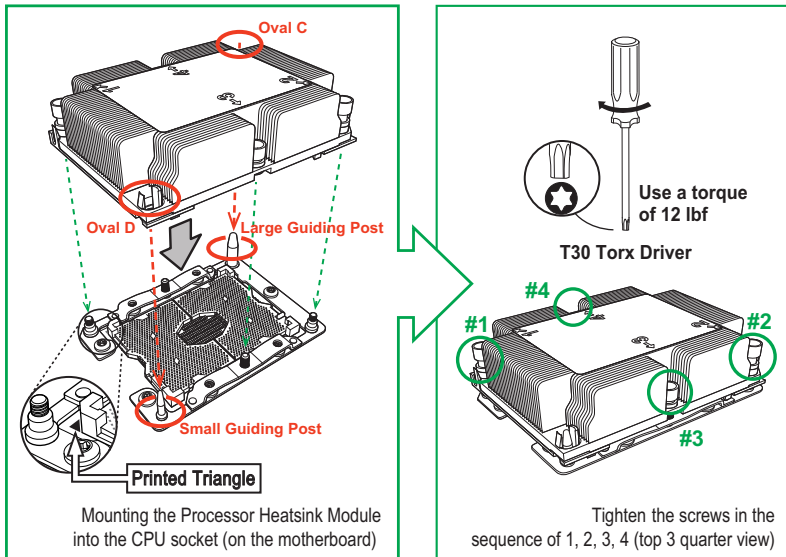

Removing the Processor Heatsink Module (PHM) from the Motherboard

Before removing the processor heatsink module (PHM), unplug power cord from the power outlet.

1. Using a T30 Torx-bit screwdriver, turn the screws on the PHM counterclockwise to loosen them from the socket, starting with screw marked #4 (in the sequence of 4, 3, 2, 1).
2. After all four screws are removed, wiggle the PHM gently and pull it up to remove it from the socket.

Note: To properly remove the processor heatsink module, be sure to loosen and remove the screws on the PHM in the sequence of 4, 3, 2, 1 as shown below.

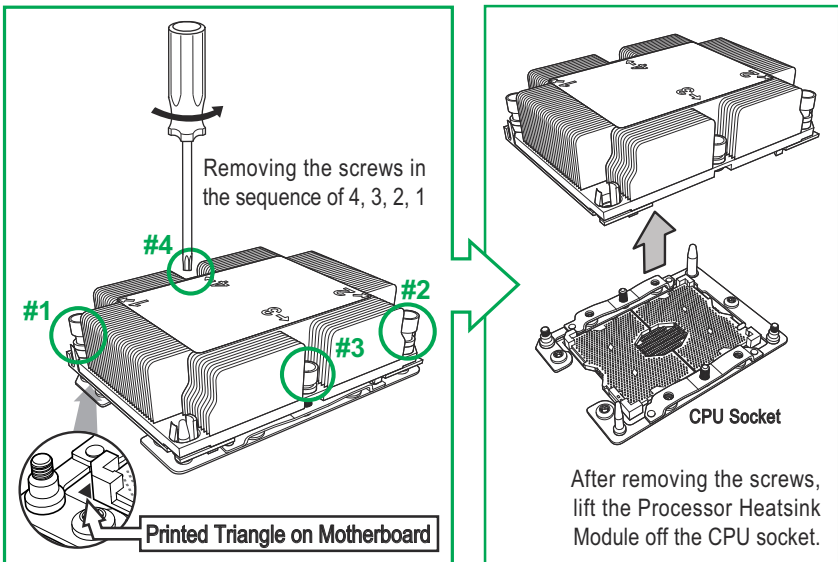

3-4 On-board Battery Installation

A battery is included on the mainboard to supply certain volatile memory components with power when power has been removed from the blade module. If this battery dies, it must be replaced with an equivalent CR2032 Lithium 3V battery. Dispose of used batteries according to the manufacturer's instructions. See [Figure 3-3](#) for a diagram of installing a new On-board battery.

Caution: There is a danger of explosion if the On-board battery is installed upside down, which reverses its polarities.

Figure 3-3. Installing the On-board Battery

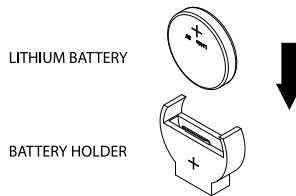

3-5 Memory Installation

The mainboard of each blade unit must be populated with DIMMs (Dual In-line Memory Modules) to provide system memory. **The DIMMs should all be of the same size and speed and from the same Super Micro authorized manufacturer due to compatibility issues.** See details below on supported memory and our web site (www.supermicro.com/products/superblade for recommended memory.

Populating Memory Slots

Each node's mainboard of a SBI-4129P-T3N/C2N blade module has sixteen (16) memory slots, four for each processor. Both interleaved and non-interleaved memory are supported, so you may populate any number of DIMM slots. For information on memory population, see [Table 3-1](#).

Total memory capacity for the module is 2 TB for RDIMM/LRDIMM per node. See [Table 3-2](#) and [Table 3-3](#) for information on supported memory types.

For better performance and capacity consistency please use the same DIMM size and the same DIMM speed. By doing this you will avoid the issue of memory down speed to the lower speed DIMM, in case of any DIMMs' speed disparity. This also allows readiness for Memory RAS with Spare Rank and Spare DIMM features which required lock steps.

For information on memory numbering, see [Figure 3-4](#).

Table 3-1. Memory Population for 16 Slots

CPUs/DIMMs	Memory Population Sequence
When 1 CPU is used:	
1	CPU1: P1-DIMMA1
2	CPU1: P1-DIMMA1/P1-DIMMD1
3	CPU1: P1-DIMMC1/P1-DIMMB1/P1-DIMMA1
4	CPU1: P1-DIMMB1/P1-DIMMA1/P1-DIMMD1/P1-DIMME1
5*	CPU1: P1-DIMMC1/P1-DIMMB1/P1-DIMMA1/P1-DIMMD1/P1-DIMME1
6	CPU1: P1-DIMMC1/P1-DIMMB1/P1-DIMMA1/P1-DIMMD1/P1-DIMME1/P1-DIMMF1
7*	CPU1: P1-DIMMC1/P1-DIMMB1/P1-DIMMA1/P1-DIMMA2/P1-DIMMD1/P1-DIMME1/P1-DIMMF1
8	CPU1: P1-DIMMC1/P1-DIMMB1/P1-DIMMA1/P1-DIMMA2/P1-DIMMD2/P1-DIMMD1/P1-DIMME1/P1-DIMMF1
When 2 CPUs are used:	
2	CPU1: P1-DIMMA1 CPU2: P2-DIMMA1
4	CPU1: P1-DIMMA1/P1-DIMMD1 CPU2: P2-DIMMA1/P2-DIMMD1
6	CPU1: P1-DIMMC1/P1-DIMMB1/P1-DIMMA1 CPU2: P2-DIMMC1/P2-DIMMB1/P2-DIMMA1
8	CPU1: P1-DIMMB1/P1-DIMMA1/P1-DIMMD1/P1-DIMME1 CPU2: P2-DIMMB1/P2-DIMMA1/P2-DIMMD1/P2-DIMME1
10*	CPU1: P1-DIMMC1/P1-DIMMB1/P1-DIMMA1/P1-DIMMD1/P1-DIMME1/P1-DIMMF1 CPU2: P2-DIMMB1/P2-DIMMA1/P2-DIMMD1/P2-DIMME1
12	CPU1: P1-DIMMC1/P1-DIMMB1/P1-DIMMA1/P1-DIMMD1/P1-DIMME1/P1-DIMMF1 CPU2: P2-DIMMC1/P2-DIMMB1/P2-DIMMA1/P2-DIMMD1/P2-DIMME1/P2-DIMMF1
14*	CPU1: P1-DIMMC1/P1-DIMMB1/P1-DIMMA1/P1-DIMMA2/P1-DIMMD1/P1-DIMME1/P1-DIMMF1 CPU2: P2-DIMMC1/P2-DIMMB1/P2-DIMMA1/P2-DIMMA2/P2-DIMMD1/P2-DIMME1/P2-DIMMF1
16*	CPU1: P1-DIMMC1/P1-DIMMB1/P1-DIMMA1/P1-DIMMA2/P1-DIMMD2/P1-DIMMD1/P1-DIMME1/P1-DIMMF1 CPU2: P2-DIMMC1/P2-DIMMB1/P2-DIMMA1/P2-DIMMA2/P2-DIMMD2/P2-DIMMD1/P2-DIMME1/P2-DIMMF1

*Unbalanced: not recommended

Notes:

1. All DIMMs must be either all DDR4 DIMMs or DDR4 and AEP/NVDIMM.
2. Populate in furthest slot from CPU if only one DIMM Populated in a channel.
3. Populate in furthest slot from CPU if only one DIMM Populated in a channel.
4. A2 and D2 reserved for AEP/NVDIMM
5. See https://www.supermicro.com/support/resources/memory/X11_memory_config_guide.pdf for details.

Table 3-2. DDR4 Support for the Intel 81xx/61xx/51xx/41xx/31xx Series Processor Platform – 2 Slots per Channel

Type	Ranks Per DIMM and Data Width	DIMM Capacity (GB)		Speed (M/Ts); Voltage (V), Slots per Channel (SPC), and DIMMs per Channel (DPC)	
				2 Slots per Channel	
				1DPC	2DPC
		4 GB	8 GB	1.2V	1.2V
RDIMM	SRx4	8 GB	16 GB	2666	2666
RDIMM	SRx8	4 GB	8 GB	2666	2666
RDIMM	DRx8	8 GB	16 GB	2666	2666
RDIMM	DRx4	16 GB	32 GB	2666	2666
RDIMM 3DS	QRx4	N/A	2H-64 GB	2666	2666
	8RX4	N/A	4H-128 GB	2666	2666
LRDIMM	QRx4	32 GB	64 GB	2666	2666
LRDIMM 3DS	QRx4	N/A	2H-64 GB	2666	2666
	8Rx4	N/A	4H-128 GB	2666	2666

Table 3-3. DDR4 Support for the Intel 81xx/61xx/51xx/41xx/31xx Series Processor Platform – 1 Slot per Channel

Type	Ranks Per DIMM and Data Width	DIMM Capacity (GB)		Speed (M/Ts); Voltage (V), Slots per Channel (SPC), and DIMMs per Channel (DPC)
				1 Slot per Channel
				1DPC
		4 GB	8 GB	1.2V
RDIMM	SRx4	8 GB	16 GB	2666
RDIMM	SRx8	4 GB	8 GB	2666
RDIMM	DRx8	8 GB	16 GB	2666
RDIMM	DRx4	16 GB	32 GB	2666
RDIMM 3DS	QRx4	N/A	2H-64 GB	2666
	8RX4	N/A	4H-128 GB	2666
LRDIMM	QRx4	32 GB	64 GB	2666
LRDIMM 3DS	QRx4	N/A	2H-64 GB	2666
	8Rx4	N/A	4H-128 GB	2666

Figure 3-4. 16-slot DIMM Numbering

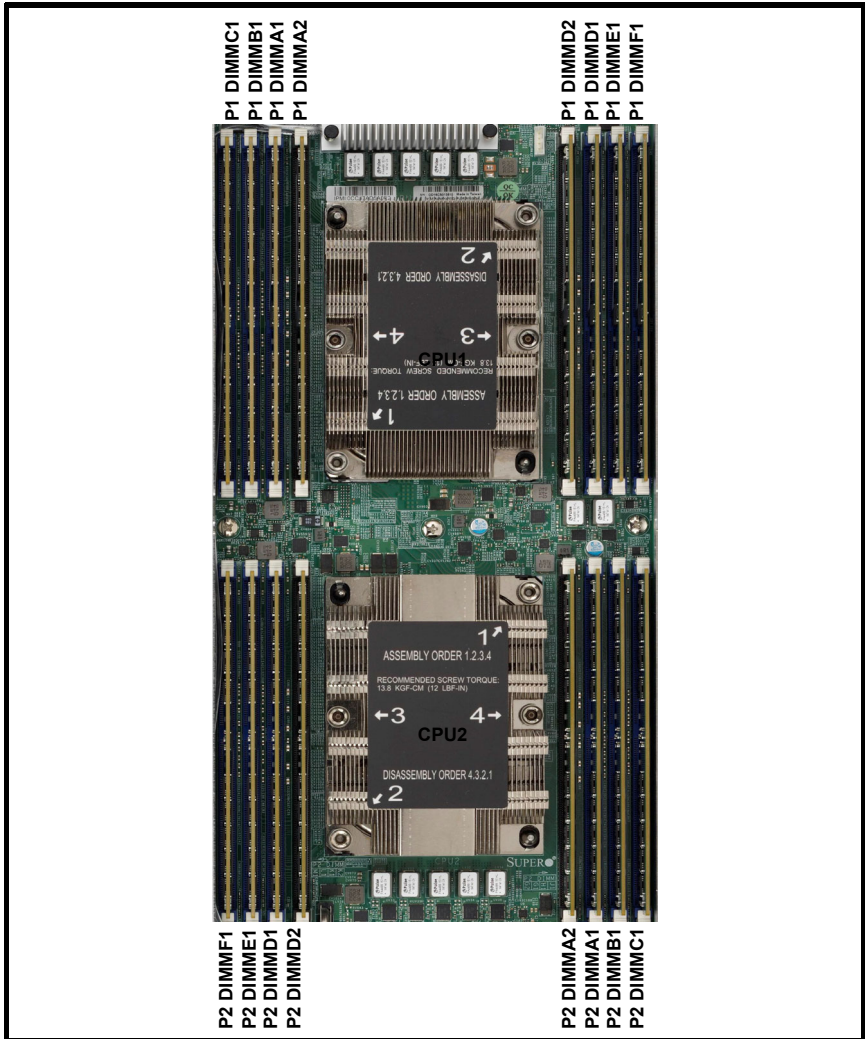

Note: Though multiple DIMM memory module types and speeds may be supported, you need to use DIMM memory modules of the same speed and type.

DIMM Installation

Warning: Exercise extreme care when installing or removing DIMM modules to prevent any possible damage.

Installing & Removing DIMMs

1. Insert the desired number of DIMMs into the memory slots, starting with P1-DIMMA1. (For best performance, please use the memory modules of the same type and speed in the same bank.)
2. Push the release tabs outwards on both ends of the DIMM slot to unlock it.

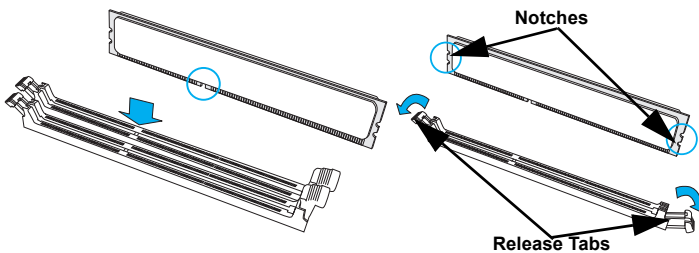

3. Align the key of the DIMM module with the receptive point on the memory slot.
4. Align the notches on both ends of the module against the receptive points on the ends of the slot.
5. Use two thumbs together to press the notches on both ends of the module straight down into the slot until the module snaps into place.
6. Press the release tabs to the locking positions to secure the DIMM module into the slot.

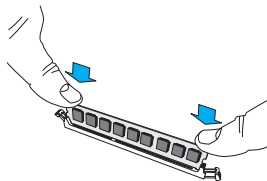

Note: Check Supermicro's website for recommended memory modules.

Removing Memory Modules

Press the release tabs on both ends of the memory module to unlock it. Once it is loosened, remove the DIMM module from the memory slot.

3-6 Hard Disk Drive Installation

Hard disk drives are installed in "carriers" which are hot-swappable and can be removed or replaced without powering down the blade unit they reside in. A blade module needs a hard disk drive with an operating system installed to operate.

Caution: To maintain proper airflow, both hard drive bays must have drive carriers inserted during operation whether or not a drive is installed in the carrier.

To remove a hard drive carrier, do the following:

Removing a Hard Drive Carrier

1. Locate the colored "Open" button at the bottom of the drive carrier and press it with your thumb. This action releases the drive carrier from the drive bay.
2. Pull the release handle out about 45-degrees, then use it to pull the drive carrier out.

To Install a hard drive, use the following procedure:

Installing a Hard Drive

1. Remove a blank drive carrier from the blade (see removal procedure above).
2. Insert a drive into the carrier with the PCB side facing down and the connector end toward the rear of the carrier.
3. Align the drive in the carrier so that the screw holes of both line up. Note that there are holes in the carrier marked "SATA" to aid in correct installation.
4. Secure the drive to the carrier with six screws as shown in [Figure 3-5](#).
5. Insert the drive carrier into its slot keeping the Open button at the bottom. When the carrier reaches the rear of the bay the release handle will retract.
6. Push the handle in until you hear the carrier click into its locked position.

Caution: Enterprise level hard disk drives are recommended for use in Supermicro chassis and servers. For information on recommended HDDs, visit the Supermicro Web site at <http://www.supermicro.com/products/nfo/files/storage/SAS-CompList.pdf>

Figure 3-5. Installing a Hard Drive in a Carrier

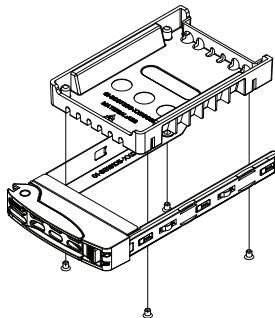

3-7 Installing a Rear Daughter Card

Depending upon your preference for the system, you may install either a rear network card or a M.2 drive daughter card with four M.2 drives into your system. Both plug into the same daughter card slot on the rear of the serverboard.

See [Figure 3-6](#) and [Figure 3-7](#) below for a comparison of both cards installed.

Figure 3-6. System with Network Daughter Card Installed



Figure 3-7. System with M.2 Daughter Card Installed



3-8 Installing the Operating System

An operating system (OS) must be installed on each blade module. Blades with Microsoft Windows OS and blades with Linux OS can both occupy and operate within the same blade enclosure. Refer to the SuperMicro web site for a complete list of supported operating systems.

There are several methods of installing an OS to the blade modules.

Installing with an External USB CD-ROM Drive

The most common method of installing the OS is with an external USB CD-ROM drive. Take the following steps to install the OS to a blade module:

Caution: Installing the OS from an external CD-ROM drive may take several hours to complete.

1. Connect an SUV cable (Serial port/USB port/Video port cable) to the KVM connector on the front of the blade module. You will then need to attach a USB hub to the USB port on this cable to provide multiple USB ports.
2. Connect the external CD-ROM drive, a USB keyboard and a mouse to the USB hub. You will also need to connect a monitor to the video connector on the SUV cable. Turn on the blade module.
3. Insert the CD containing the OS into the CD-ROM drive.
4. Follow the prompts to begin the installation.

Installing via PXE Boot

PXE (Preboot Execution Environment) is used to boot a computer over a network. To install the OS via PXE, the following conditions must be met:

1. The PXE BOOT option in BIOS must be enabled.
2. A PXE server has been configured (this can be another blade in the system).
3. The PXE server must be connected over a network to the blade to be booted.
4. The blade has only non-partitioned/unformatted hard drives installed and no bootable devices attached to it.

Once these conditions are met, make sure the PXE server is running. Then turn on the blade on which you wish to boot and/or install the OS. The BIOS in the blade will look at all bootable devices and finding none will connect to the PXE server to begin the boot/install.

Installing via Virtual Media (Drive Redirection)

You can install the OS via Virtual Media through either the *IPMIview* (Java based client utility), *IPMItool* or the *Web-based Management Utility*. With this method, the OS is installed from an ISO image that resides on another system/blade.

Refer to the manuals on your SuperBlade CD-ROM for further details on the Virtual Media (CD-ROM or Drive Redirection) sections of these two utility programs.

3-9 Management Software

System management may be performed with either of three software packages: *IPMIview*, *IPMITool* or a *Web-based Management Utility*. These are designed to provide an administrator with a comprehensive set of functions and monitored data to keep tabs on the system and perform management activities.

Refer to the manuals on your SuperBlade CD-ROM for further details on the various functions provided by these management programs.

3-10 Configuring and Setting up RAID

Each blade module that supports two or more hard drives may be used to create a RAID array. The procedures for doing this vary depending upon the blade model chosen for your SuperBlade system. For this module 0 and 1 is available for each node.

For RAID setup see <http://www.supermicro.com/support/manuals/> under RAID Installation Guides for more details.

Chapter 4

Blade Module Features

Figure 4-1. SBI-4129P-T3N/C2N Blade Unit Front View



This chapter describes the SBI-4129P-T3N/C2N blade unit. Installation and maintenance should be performed by experienced technicians only.

See [Figure 4-1](#) for a front view of the blade unit and [Table 4-1](#) for its features.

Table 4-1. SBI-4129P-T3N/C2N Blade Unit Features

Feature	Description
Processors	Supports single or dual Socket P LBA 3647 Intel Xeon processor EP series processors per node
Memory	Supports up to 2 TB of RDIMM/LRDIMM DDR4 2400/2666 MHz speed, 8 GB, 16 GB, 32 GB, 64 GB and 128 GB size SDRAM memory in sixteen (16) 288-pin DIMM sockets per node. See https://www.supernmicro.com/support/resources/memory/X11_memory_config_guide.pdf for details.
Storage	Either two hot-plug 2.5" NVMe/SAS3 (SBI-4129P-C2N), or two hot-plug 2.5" NVMe and one SATA3 or three SATA3 (SBI-4129P-T3N)
Ports	One KVM port, dual port 10-Gigabit Ethernet
Features	On-board Integrated Aspeed AST 2500 VGA Graphics chip, Intel® I/OAT 3, VMDq, IPMI 2.0, ATA/100, Plug and Play, APM 1.2, DMI 2.3, PCI 2.2, ACPI 1.0/2.0, SMBIOS 2.3, Real Time Clock, Watch Dog,

4-1 Control Panel

Each blade has a similar control panel (Figure 4-2) with power on/off button, a KVM connector, a KVM button and four LEDs on the top front of the unit. The numbers mentioned in Figure 4-2 are described in Table 4-2.

Figure 4-2. Blade Control Panel

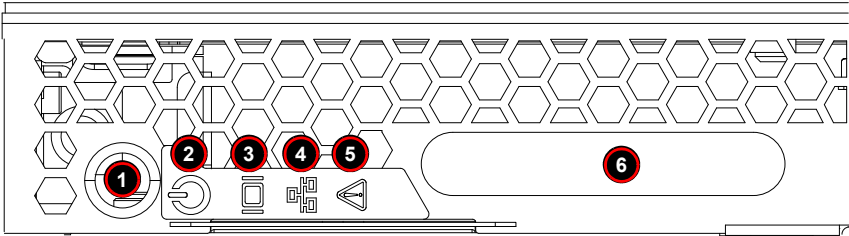

Table 4-2. Blade Control Panel

Item	Function	State	Description
1	Power Button	N/A	Turns blade module on and off
2	Power LED	Green	Indicates power status "On"
		Solid Orange	Indicates power status "Off" (with power cables plugged in)
		Flashing Orange	Flashing Orange: Indicates node is not ready or not enough power to turn on
3	KVM/UID LED	Blue	Indicates KVM being utilized on blade unit
		Flashing Blue	Indicates UID activated on blade module
4	Network/IB LED	Flashing Green	Indicates network activity over LAN
		Flashing Orange	Indicates network activity over InfiniBand module
5	System Fault LED	Red	Indicates a memory error, overheat, VGA error or any error that prevents booting
6	KVM Connector	N/A	Connector for SUV/KVM cable

Power Button

Each blade has its own power button so that individual blade units within the enclosure may be turned on or off independently of the others. Press the power button (#1) to turn on the blade server. The power LED (#2) will turn green. To turn off, press and hold the power button for >4 seconds and the power LED will turn orange.

KVM Connector

Alternatively, you may connect a KVM cable (CBL-0218L, with a keyboard/video/mouse attached) to the KVM connector (#6) of the blade you wish to access. To switch to another blade, disconnect the cable then reconnect it to the new blade.

See the *Web-based Management Utility User's Manual* on your SuperBlade system CD-ROM for further details on using the KVM function remotely.

4-2 Mainboard

The mainboard of the SBI-4129P-T3N/C2N blade unit is a proprietary design, which is based on the Intel C622 chipset. See [Figure 4-4](#) for a block diagram of this chipset, [Figure 4-3](#) for a view of the B11DPT mainboard and [Figure 4-5](#) for an exploded view diagram of the blade unit.

Figure 4-3. B11DPT Mainboard

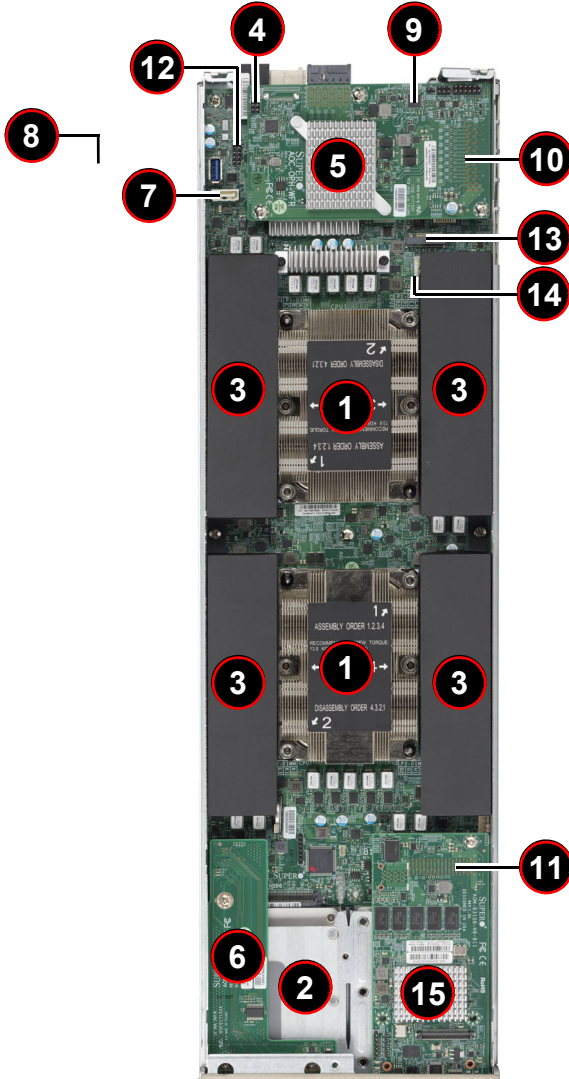
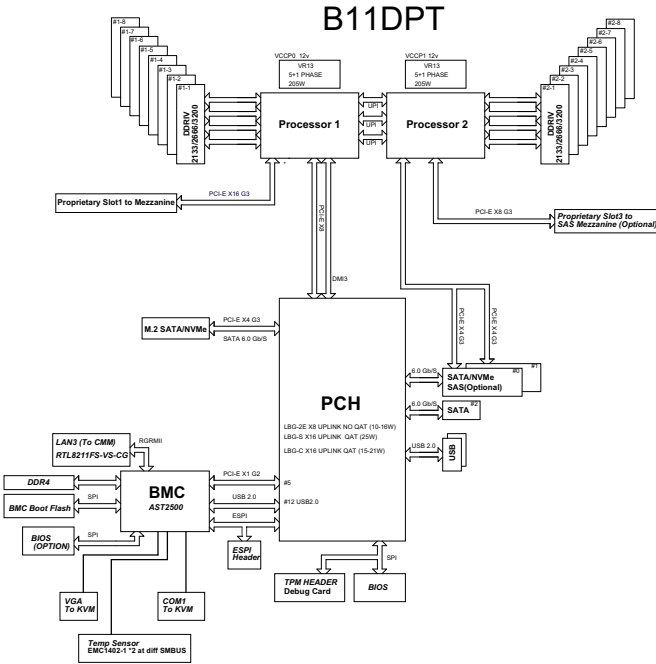

Table 4-3. B11DPT Mainboard Layout

Item	Description
1	CPUs installed (see Figure 3-5 for details on CPU numbering, two total)
2	Front housing for two (SBI-4129P-C2N) or three (SBI-4129P-T3N) 2.5" SATA3/SSD/NVMe hard drive bays
3	DIMM slots (see Figure 3-5 for details, sixteen total)
4	Power and Logic connectors to backplane
5	Intel C622 chipset
6	Front panel module card (KVM cards)
7	SATA port
8	RAIDKEY
9	Integrated Aspeed AST 2500 BMC with VGA Graphics Chips
10	InfiniBand or M.2 daughter card slot
11	SAS/SATA daughter card slot
12	9-pin TPM Connector
13	On-board M.2 Connector
14	Intel VROC upgrade key for NVMe
15	AOC SAS Controller (SBI-4129P-C2N only)

Figure 4-4. SBI-4129P-T3N/C2N System Block Diagram



CMOS Clear

JBT1 is used to clear CMOS and will also clear any passwords. This consists of two contact pads located near the BIOS chip.

Clearing CMOS

1. First power down the blade and remove it from the enclosure.
2. Remove the blade cover to access the mainboard (see ["Removing/Replacing the Blade Cover"](#) on page 3-2 for further details). Short the CMOS pads with a metal object such as a small screwdriver.
3. Replace the cover, install the blade back into the enclosure and power it on.

Jumper Settings

The following jumper settings can be used for the SBI-4129P-T3N/C2N blade modules:

Table 4-4. Jumper Settings

Jumper	Default Setting	Notes
JWD1	Pins 1-2	Pins 1-2: Time to reset (Default); Pins 2-3: Timeout to NMI
JPME1/2	Pins 1-2	Pins 1-2: ME normal operation (Default); Pins 2-3: ME Recovery Mode
JVRM1/2	Pins 1-2	Normal Operation (Default)

4-3 Blade Unit Components

Figure 4-5. Exploded View of a SBI-4129P-T3N/C2N Blade Module

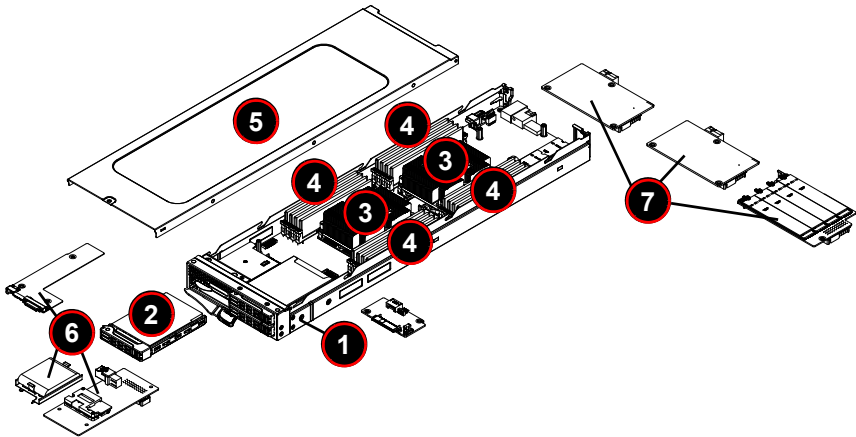

Table 4-5. Main Components of a SBI-4129P-T3N/C2N Blade Module

Item	Description
1	Blade Unit/Module
2	2.5" Hard Drives (up to three)
3	CPUs/Heatsinks (2)
4	DIMM slots (16)
5	Top Cover
6	Front Panel Module Cards
7	Rear Module Cards

Memory Support

The SBI-4129P-T3N/C2N SuperBlade module supports up to 2 TB of RDIMM, 128 GB of UDIMM and 2 TB LRDIMM DDR4 2400/2666 MHz speed, 8 GB, 16 GB, 32 GB, 64 GB and 128 GB size SDRAM memory in sixteen (16) 288-pin DIMM sockets per node. See [Section 3-5: Memory Installation on page 3-13](#) for further details on mainboard memory installation.

Hard Disk Drives

The SBI-4129P-T3N/C2N blade unit accommodates up to three 2.5" SATA/SSD/NVMe hard disk drives (max two NVMe), which are mounted in drive "trays". The drives can be hot-swapped and removed or replaced without powering down the blade unit they reside in. The three drives can be used to set up a RAID array. These drives use a blue color for the Blade HDD active LED. See [Chapter 1](#) for information on RAID Setup.

Additional drives can be added by a module card mounted in the front.

For RAID setup see <http://www.supermicro.com/support/manuals/> under RAID Installation Guides for details.

Caution: To maintain proper airflow, both hard drive bays must have drive carriers inserted during operation whether or not a drive is installed in the tray.

WARNING: Enterprise level hard disk drives are recommended for use in Supermicro chassis and servers. For information on recommended HDDs, visit the Supermicro Web site at <http://www.supermicro.com/products/nfo/storage.cfm>

Chapter 5

BIOS

5-1 Introduction

This chapter describes the BIOS for Intel SuperBlade modules. The Intel Blade modules use a 256 Mb SPI Flash EEPROM with AMI® BIOS that is stored in a flash chip. This BIOS can be easily upgraded using a floppy disk-based program.

Note: Due to periodic changes to the BIOS, some settings may have been added or deleted and might not yet be recorded in this manual. Please refer to the <http://www.supermicro.com/products/SuperBlade/module/> web site for further details on BIOS setup and the BIOS menus for your SuperBlade blade module.

System BIOS

BIOS stands for Basic Input Output System. The 256 Mb SPI Flash EEPROM with AMI® BIOS flash chip stores the system parameters, types of disk drives, video displays, in the CMOS. The CMOS memory requires very little electrical power. When the blade unit is turned off, a backup battery provides power to the BIOS flash chip, enabling it to retain system parameters. Each time the blade is powered on it is configured with the values stored in the BIOS ROM by the system BIOS, which gains control at boot up.

How To Change the Configuration Data

The CMOS information that determines the system parameters may be changed by entering the BIOS Setup utility. This Setup utility can be accessed by pressing the <DELETE> key at the appropriate time during system boot. (See "[Starting the Setup Utility](#)" below.)

Starting the Setup Utility

Normally, the only visible POST (Power-On Self-Test) routine is the memory test. As the memory is being tested, press the <DELETE> key to enter the main menu of the BIOS Setup utility. From the main menu, you can access the other setup screens, such as the Security and Power menus.

Caution: To prevent possible boot failure, do not shut down or reset the system while updating the BIOS.

5-2 BIOS Updates

It may be necessary to update the BIOS used in the blade modules on occasion. However, it is recommended that you not update BIOS if you are not experiencing problems with a blade module.

Updated BIOS files are located on our web site(www.supermicro.com/products/superblade/). Please check the current BIOS revision and make sure it is newer than your current BIOS before downloading.

There are several methods you may use to upgrade (flash) your BIOS. After downloading the appropriate BIOS file (in a zip file format), follow one of the methods described below to flash the new BIOS.

Flashing BIOS

Use the procedures below to “Flash” your BIOS with a new update using the KVM dongle, USB ports on the CMM module or by use of a Floppy disk.

Flashing a BIOS using the KVM Dongle:

For this method, you must use a KVM “dongle” cable (CBL-0218L, included with the system).

1. Copy the contents of the zip file to a bootable USB pen drive.
2. Connect the KVM dongle (CBL-0218L) to the KVM connector at the front of the blade you will be flashing the BIOS to.
3. Connect your bootable USB pen drive to one of the two USB slots on the KVM dongle.
4. Boot to the USB pen drive and go to the directory where you saved the contents of the zip file.
5. Type **flash filename.rom** (replace *filename.rom* by the actual ROM file name).

5-3 Running Setup

Note: Default settings are in **bold** text unless otherwise noted.

The BIOS setup options described in this section are selected by choosing the appropriate text from the MAIN BIOS SETUP screen. All displayed text is described in this section, although the screen display is often all you need to understand how to set the options.

When you first power on the computer, the BIOS is immediately activated.

While the BIOS is in control, the Setup program can be activated in one of two ways:

1. By pressing <DELETE> immediately after turning the system on, or
2. When the message **Press the <Delete> key to enter Setup** appears briefly at the bottom of the screen during the POST, press the <DELETE> key to activate the main SETUP menu:

5-4 Main BIOS Setup

Figure 5-1. Main BIOS Setup Screen

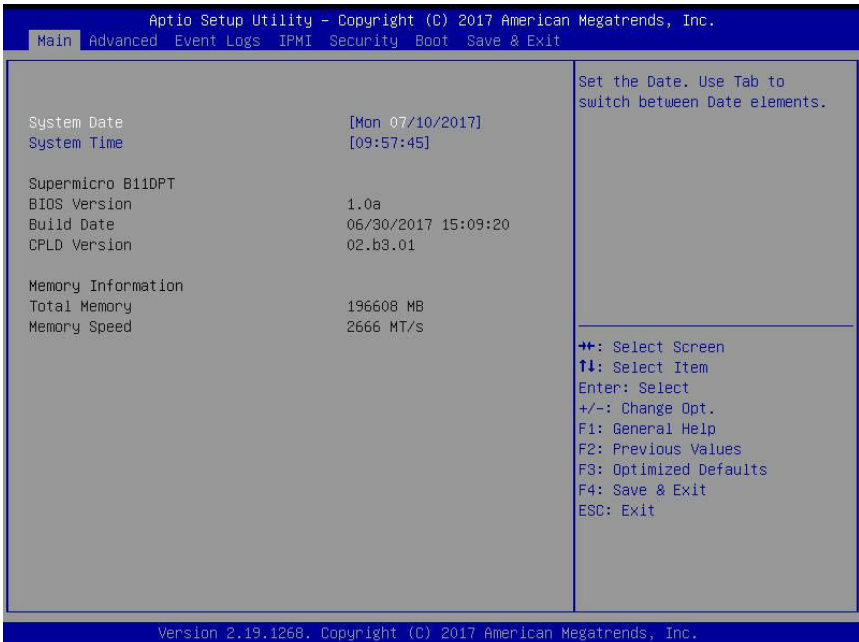

All Main Setup options are described in this section.

Use the UP/DOWN arrow keys to move among the different settings in each menu. Use the LEFT/RIGHT arrow keys to change the options for each setting.

Press the <ESC> key to exit the CMOS SETUP menu. The next section describes in detail how to navigate through the menus.

Items that use sub-menus are indicated with the ► icon. With the item highlighted, press the <ENTER> key to access the sub-menu.

Menu options found in the MAIN BIOS SETUP menu are described in [Table 5-1](#).

Table 5-1. Main BIOS Setup Menu Options

Menu Option	Description
System Date	Using the arrow keys, highlight the month, day and year fields, and enter the correct data for the system date. Press the <Enter> key to save the data.
System Time	To set the system date and time, key in the correct information in the appropriate fields. Then press the <Enter> key to save the data.
BIOS Information	BIOS static display information including the motherboard number, SMC version, SMC Build Date and Total Memory is also shown on the screen.

5-5 Advanced Setup

Figure 5-2. BIOS Setup Screen

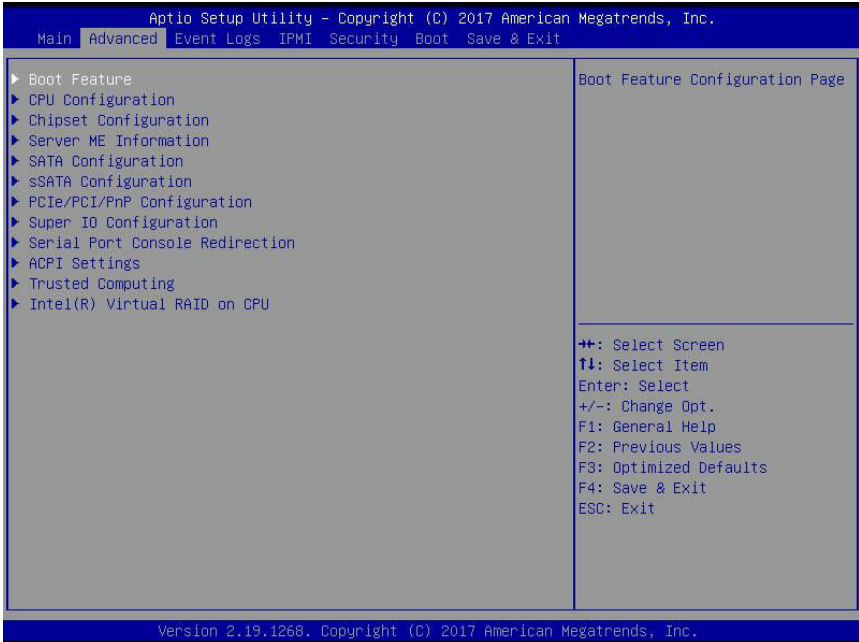

Choose **Advanced** from the BIOS Setup Utility main menu with the arrow keys to display the **ADVANCED SETUP** menu. The items with a triangle beside them are sub-menus that can be accessed by highlighting the item and pressing <ENTER>. Options for PIR settings are displayed by highlighting the setting option using the arrow keys and pressing <ENTER>.

Table 5-2 describes all sub-menus found in the **ADVANCED SETUP** menu.

Table 5-2. Advanced Setup Menu Options

Sub-menu	Description
▶ Boot Feature	See Table 5-3 for a description of BIOS setup menu options in this sub-menu.
▶ CPU Configuration	See Table 5-4 for a description of BIOS setup menu options in this sub-menu.
▶ Chipset Configuration	See Table 5-5 for a description of BIOS setup menu options in this sub-menu.
Server Me Information	See Table 5-6 for a description of BIOS setup menu options in this sub-menu.
▶ SATA Configuration	See Table 5-7 for a description of BIOS setup menu options in this sub-menu.
▶ sSATA Configuration	See Table 5-8 for a description of BIOS setup menu options in this sub-menu.
▶ PCIe/PCI/PnP Configuration	See Table 5-9 for a description of BIOS setup menu options in this sub-menu.
▶ Super IO Configuration	See Table 5-10 for a description of BIOS setup menu options in this sub-menu.
▶ Serial Port Console Redirection	See Table 5-11 for a description of BIOS setup menu options in this sub-menu.
▶ ACPI Settings	See Table 5-12 for a description of BIOS setup menu options in this sub-menu.
▶ Trusted Computing	See Table 5-13 for a description of BIOS setup menu options in this sub-menu.
▶ Intel(R) Virtual RAID on CPU	See Table 5-14 for a description of BIOS setup menu options in this sub-menu.

Table 5-3. Boot Feature sub-menu

Menu Option	Description
Quiet Boot	When Disabled the BIOS displays normal POST messages. When Enabled the BIOS displays an OEM Logo instead of POST messages.
Option ROM Messages	Use this setting to set the display mode for Option ROM to either Force BIOS or Keep Current.
Bootup NUM-Lock State	This setting selects the Power-On state for Numlock. Options include On or Off.
Wait for 'F1' If Error	When enabled, the system will wait for the F1 key to be pressed if an error occurs. Options are Enabled or Disabled.
Interrupt 19 Capture	When enabled this setting allows option ROMs to trap Interrupt 19. Options include Immediate or Postponed.
Re-try Boot	Use this setting to specify the Re-try Boot option to use. Options include Disabled , Legacy Boot or EFI Boot.
Watch Dog Function	This setting allows the system to restart when it is not active more than 5 minutes. Option include Enabled and Disabled .
Power Button Function	This setting specifies the power button's function when pressed. Option include 4 Seconds Override or Instant Off .

Table 5-4. CPU Configuration sub-menu

Menu Option	Description
Processor Configuration Information	This section shows static information on the processor configuration.
Hyper-threading [ALL]	This setting is Enabled for Windows XP and Linux (OS optimized for Hyper-threading technology), and Disabled for other OSes (any OS not optimized for Hyper-threading technology). When Disabled, only one thread per enabled core is enabled.
Execute Disable Bit	XD can prevent certain classes of malicious buffer overflow attacks when combined with a supporting OS such as Windows Server 2003 SP1, Windows XP SP2, SuSE Linux 9.2 or RedHat Enterprise 3 Update 3. Options include Enabled or Disabled.
Intel® Virtualization Technology	Select Enabled to use this Virtualization Technology feature to allow one platform to run multiple operating systems and applications in independent partitions, creating multiple "virtual" systems in one physical computer system. The options are Enabled and Disabled. Please refer to the Intel website for further detailed information. NOTE: A full reset of the system is required when you change this setting.
PPIN Control	Use this setting to enable/disable the PPIN control. Options include Unlock/Enable or Unlock/Disable.
Hardware Prefetcher	This settings allows you to Enable or Disable the Hardware Prefetcher.
Adjacent Cache Prefetch	This setting allows you to Enable or Disable the Adjacent Cache Prefetch.
DCU Streamer Prefetcher	This setting allows you to Enable or Disable the DCU Streamer Prefetcher, which is an L1 data cache prefetcher.

Table 5-4. CPU Configuration sub-menu (Continued)

Menu Option	Description
DCU IP Prefetcher	This setting allows you to Enable or Disable the DCU IP Prefetcher, which is an L1 data cache prefetcher.
LLC Prefetch	This setting allows you to enable or disable the LLC Prefetch on all threads. Options include Enable or Disable.
Extended APIC	Use this setting to Enable or Disable extended APIC support
AES-NI	Use this setting to Enable or Disable AES-NI support.
▶ Advanced Power Management Configuration	This submenu display and provides options to change the Power Management Settings.
▶ CPU P State Control	Use this submenu to specify options for CPU P-State controls.
SpeedStep (Pstates)	This setting allows you to Enable or Disable EIST (P-States).
EIST PSD Function	For this setting, choose a setting for the EIST PSD function. Options include HW_ALL , SW_ALL , or SW_ANY .
Turbo Mode	This setting allows you to Enable or Disable the processor Turbo Mode for your system. Note: This requires EMTTM be enabled also.
▶ Hardware PM State Control	Use this submenu for specifying Hardware PM State controls.
Hardware P-States	Use this setting to specify an option for Hardware P-States. Options include the following: <ul style="list-style-type: none"> • Disable – The hardware chooses a P-State based upon the OS request (Legacy P-States). • Native Mode – The hardware chooses a P-State based upon the OS guidance. • Out of Band Mode – The hardware autonomously chooses a P-State (No OS guidance). • Native Mode with No Legacy Support
▶ CPU C State Control	Use this submenu to select a CPU C-State controls.
Autonomous Core C-State	This setting allows you to Enable or Disable the Autonomous Core C-State control for your system.
CPU C6 Report	This setting allows you enable/disable a CPU C6 (ACPI C3) report to the OS. Options include Disable, Enable and Auto .
Enhanced Halt State (C1E)	Use this setting to Enable or Disable Core C1E auto promotion control. Note: This setting only takes effect after a reboot.
▶ Package C State Control	Use this submenu to specify Package C-State controls.
Package C State	This setting allows you to specify a Package C State option. Options include: C0/C1 state, C2 state, C6 (non-retention) state, C6 (Retention) state, No Limit and Auto .

Table 5-5. Chipset Configuration Sub-menu

Menu Option	Description
►North Bridge Configuration	This sub-menu configures North Bridge features and shows configuration information.
►UPI Configuration	
UPI General Configuration Information	This static information shows UPI General Configuration information for your system.
Degrade Precedence	Use this setting to select the Degrade Precedence. Choose Topology Precedence to degrade features if the system options are in conflict. Choose Feature Precedence to degrade topology if the system options are in conflict.
Link L0p Enable	Use this setting to enable/disable Link L0p. Options include Disable, Enable or Auto .
Link L1 Enable	Use this setting to enable/disable Link L1. Options include Disable, Enable or Auto .
IO Directory Cache (IODC)	The IO Directory Cache (IODC) generates snoops instead of memory lookups, for remote InvltOM (ITO) and/or WCiLF (cores). Options include the following: <ul style="list-style-type: none"> • Disable • Auto (sets to WCiLF) • Enable for Remote InvltOM Hybrid Push InvltOM AllocFlow • Enable for Remote InvltOM Hybrid AllocNonAlloc • Enable for Remote InvltOM and Remote WViLF
Isoc Mode	This sets Isoc Mode to either Enable, Disable or Auto .
►Memory Configuration	This sub-menu displays Memory Configuration settings.
Enforce POR	This setting allows you to enforce POR restrictions for DDR4 frequency and voltage programming. Options include POR or Disabled.
Memory Frequency	This setting sets the maximum memory frequency in Mhz. Options are Auto and frequency values from 1866 ~ 2666 Mhz.
Data Scrambling for NVMDIMM	Use this setting to enable data scrambling for NVMDIMM. Options include Auto (sets it to the MRC default), Disabled and Enabled.
Data Scrambling for DDR4	Use this setting to enable data scrambling for DDR4. Options include Auto (sets it to the MRC default), Disabled and Enabled.
tCCD_L Relaxation	Use this setting to specify if the tCCD_L is overridden by the SPD or based on the memory frequency. Options include Auto , Disable and Enable.
Enable ADR	This setting enables the detecting and enabling of ADR. Options include Enable or Disable .
►Memory Topology	This submenu, when selected, provides with you with static information for memory topology.
►Memory RAS Configuration	This submenu displays and provides options to change the Memory RAS settings.

Table 5-5. Chipset Configuration Sub-menu (Continued)

Menu Option	Description
Static Virtual Lockstep Mode	Use this setting to Enable or Disable Static Virtual Lockstep mode.
Mirror Mode	Mirror Mode will set the entire 1LM/2LM memory in the system to be mirrored, consequently reducing the memory capacity by half. Options include Disable , Mirror Mode 1LM and Mirror Mode 2LM. Note: Mirror Enable will disable XPT Prrefetch.
Memory Rank Sparing	This setting will Enable or Disable Memory Rank Sparing for your system.
Correctable Error Threshold	Use this setting to set a threshold value from 1 ~32767 for the Correctable Error Threshold used for sparing, tagging and leaky bucket. Use the + or - keys on your numpad to toggle up or down a value or type in a number value for the field for this setting. Default value is 10 .
SDDC	This value Enables or Disables SDDC for your system.
ADDCC Sparing	This value Enables or Disables ADDCC Sparing for your system.
Patrol Scrub	This setting Enables or Disables Patrol Scrub in your system.
Patrol Scrub Interval	This setting selects the number of hours (1-24) required to complete full scrub. A value of 0 means auto. Default is 24 . Settings are increased or decreased using the "+" or "-" keys on your keyboard's number pad.
► IIO Configuration	This sub-menu configures Integrated I/O Configuration.
EV DFX Features	This setting gives you the option to allow DFX Lock Bits to remain clear or not. Options include Enable or Disable .
► CPU1 Configuration	This submenu allows you to configure CPU1 configuration options.
IOU0 (IIO PCIe Br1)	This setting selects the PCIe port bifurcation for Br1. Options include x4x4x4x4, x4x4x8, x8x4x4, x8x8, x16 or Auto .
IOU1 (IIO PCIe Br2)	This setting selects the PCIe port bifurcation for Br2. Options include x4x4x4x4, x4x4x8, x8x4x4, x8x8, x16 or Auto .
IOU2 (IIO PCIe Br3)	This setting selects the PCIe port bifurcation for Br3. Options include x4x4x4x4, x4x4x8, x8x4x4, x8x8, x16 or Auto .
MCP0 (IIO PCIe Br4)	This setting selects the PCIe port bifurcation for Br4. Options include x16 or Auto .
MCP1 (IIO PCIe Br5)	This setting selects the PCIe port bifurcation for Br5. Options include x16 or Auto .
► Socket 0 PcieBr0D00F0 - Port 0/DMI Submenu	Settings for this submenu are related to PCI Express Ports in your system. This submenu contains a mix of static information and configurable option settings.
Link Speed	This setting specifies the link speed for the PCI-E port. Options include Auto , Gen 1 (2.5 GT/s), Gen 2 (5 GT/s) and Gen 3 (8GT/s)
PCI-E Port Max Payload Size	This sets the max payload size. Options include 128B, 256B or Auto .

Table 5-5. Chipset Configuration Sub-menu (Continued)

Menu Option	Description
▶ CPU2 Configuration	This submenu allows you to configure CPU2 configuration options.
IOU0 (IIO PCIe Br1)	This setting selects the PCIe port bifurcation for Br1. Options include x4x4x4x4, x4x4x8, x8x4x4, x8x8, x16 or Auto .
IOU1 (IIO PCIe Br2)	This setting selects the PCIe port bifurcation for Br2. Options include x4x4x4x4, x4x4x8, x8x4x4, x8x8, x16 or Auto .
IOU2 (IIO PCIe Br3)	This setting selects the PCIe port bifurcation for Br3. Options include x4x4x4x4, x4x4x8, x8x4x4, x8x8, x16 or Auto .
MCP0 (IIO PCIe Br4)	This setting selects the PCIe port bifurcation for Br4. Options include x16 or Auto .
MCP1 (IIO PCIe Br5)	This setting selects the PCIe port bifurcation for Br5. Options include x16 or Auto .
▶ IOAT Configuration	This submenu allows you to configure IOAT configuration options.
Disable TPH	This setting lets you turn on/off TLP Processing Hint disabling. Options are Yes or No .
Prioritize TPH	This setting allows you to Enable or Disable the Prioritize TPH option.
Relaxed Ordering	This setting Enables or Disables relaxed ordering in your system.
▶ Intel VT for Directed I/O (VT-d)	Use this submenu to bring up options for Intel VT for Directed I/O configurations.
Intel VT for Directed I/O (VT-d)	This setting allows you to Enable or Disable Intel Virtualization Technology for Directed I/O (VT-d) by reporting the I/O device assignment to VMM through the DMAR ACPI Tables.
Interrupt Remapping	This setting allows you to Enable or Disable the VT_D Interrupt Remapping support.
Passthrough DMA	This setting allows you to Enable or Disable the Non-Isoch VT_D Engine Pass Through DMA support.
ATS	This setting allows you to Enable or Disable the Non-Isoch VT_D Engine ATS support.
Posted Interrupt	This setting allows you to Enable or Disable the VT_D Posted Interrupt.
Coherency Support (Non-Isoch)	This setting allows you to Enable or Disable the VT_D Engine Coherency support.
▶ Intel VMD Technology Submenu	Use this submenu to bring up options for Intel VMD Technology configuration options.
▶ Intel VMD for On-board NVMe submenu	Use this submenu to bring up options for Intel VMD for On-board NVMe configuration options.
On-board NVMe Mode	This setting selects Legacy Mode or VMD Mode options for On-board NVMe.

Table 5-5. Chipset Configuration Sub-menu (Continued)

Menu Option	Description
PCIe Hot Plug	This setting allows you to Enable/Disable PCIe Hot Plug globally. Options include Disable , Enable, Auto and Manual.
PCI-E Completion Timeout (Global)	This setting allows you to Enable/Disable the Completion Timeout, where x is 0-3. Options include Yes, No and Per-Port.
►South Bridge Configuration	This sub-menu allows you to configure South Bridge parameters.
USB Information	Static information for USB Module Version and USB devices connected is shown at the top of this screen.
Legacy USB Support	This setting allows you to enable the use of Legacy USB devices. If this option is set to Auto, legacy USB support will be automatically enabled if a legacy USB device is installed on the mainboard, and disabled if no USB devices are connected. The Disable option will keep USB devices available only for EFI applications. The options include Disabled, Enabled and Auto.
XHCI Hand-off	This is a workaround for OSes without XHCI hand-off support. The XHCI ownership change should be claimed by the XHCI driver. Options include Enabled and Disabled.
Port 60/64 Emulation	This setting Enables or Disables I/O port 60h/64h emulation support. This should be enabled for the complete USB keyboard legacy support for non-USB aware OSes.
Port 61h Bit-4 Emulation	This setting allows you to Enable or Disable Port 61h Bit-4 Emulation.
Install Window 7 USB Support	This setting allows you to Enable or Disable installation of Windows 7 USB support to your system..

Table 5-6. Server ME Information Sub-menu

Menu Option	Description
General ME Configuration Information	General ME configuration information is displayed at the top of this screen.

Table 5-7. SATA Configuration Sub-menu

Menu Option	Description
SATA Controller	This setting allows you to Enable or Disable the SATA device.
Configure SATA as	Use this setting to select the SATA mode you desire. Options include IDE, AHCI and RAID.
SATA HDD Unlock	Use this setting to Enable or Disable the HDD password unlock in the OS.
Aggressive Link Power Management	Use this setting to Enable or Disable SALP.
SATA Port 0~2 Settings	For each of the ports you may configure the settings listed below.
Hot Plug	Use this setting to Enable or Disable the port as Hot Pluggable.
Spin Up Device	This setting allows you to Enable or Disable the Spin up Device for the system. If enabled for any ports staggered spin up will be performed and only the drives that have this option enabled will spin up at boot. Otherwise all drives spin up at boot if this setting is disabled.
SATA Device Type	This setting allows you to identify that the SATA port is connected to either a Solid State Drive or a Hard Disk Drive .

Table 5-8. sSATA Configuration Sub-menu

Menu Option	Description
sSATA Controller	This setting allows you to Enable or Disable the SATA controller.
Configure sSATA as	Use this setting to select the SATA mode you desire. Options include IDE, AHCI and RAID.
SATA HDD Unlock	Use this setting to Enable or Disable the HDD password unlock in the OS.
Aggressive Link Power Management	Use this setting to Enable or Disable SALP.
sSATA Port 0~5 Settings	For each of the ports you may configure the settings listed below.
Hot Plug	Use this setting to Enable or Disable the port as Hot Pluggable.
Spin Up Device	This setting allows you to Enable or Disable the Spin up Device for the system. If enabled for any ports staggered spin up will be performed and only the drives that have this option enabled will spin up at boot. Otherwise all drives spin up at boot if this setting is disabled.
sSATA Device Type	This setting allows you to identify that the SATA port is connected to either a Solid State Drive or a Hard Disk Drive .

Table 5-9. PCIe/PCI/PnP Configuration Sub-menu

Menu Option	Description
PCI Bus Driver Version	The installed version for the PCI Bus Driver is static displayed here for your information.
PCI Devices Common Settings	
Above 4G Decoding	Select Enabled to decode a 64-bit PCI device in the space above 4G Address. The options are Enabled and Disabled.
SR-IOV Support	If the system has SR-IOV capable PCIe device, this option Enables or Disables single root I/O virtualization support.
MMIO High Base	Use this setting to select the MMIO High Base. Options include 56T , 48T, 24T, 16T, 4T and 1T.
MMIO High Granularity Size	This setting selects the allocation size used to assign MMIOH resources. The total MMIOH space can be up to 32xgranularity. Per stack MMIOH resource assignments are multiples of the granularity where 1 unit per stack is the default allocation. Options are numbers 1G~1024G where 256G is the default.
PCI PERR/SERR Support	This setting Enables or Disables the runtime event for SERR/PERR errors.
Maximum Read Request	Select Auto to allow the system BIOS to automatically set the maximum Read Request size for a PCI-E device to enhance system performance. The options are Auto , 128 Bytes, 256 Bytes, 512 Bytes, 1024 Bytes, 2048 Bytes, and 4096 Bytes.
MMCFG Base	This setting selects the MMCFG base. Options include 1G, 1.5G, 1.75G, 2G , 2.25G and 3G.
VGA Priority	This setting decides the priority between On-board and the first Offboard video device found.
PCI Devices Option ROM Settings	
On-board NVME 1 OPROM	This setting enables/disables the On-board NVMe OPROM option. Options include Disabled, Legacy and EFI .
On-board NVME 2 OPROM	This setting enables/disables the On-board NVMe OPROM option. Options include Disabled, Legacy and EFI .
CPU1 Slot 1 PCI-E x8 OPROM	This setting enables/disables the PCI-E Slot OPROM option. Options include Disabled, Legacy and EFI.
CPU1 Slot2 PCI-E x16 OPROM	This setting enables/disables the PCI-E Slot OPROM option. Options include Disabled, Legacy and EFI.
CPU1 Slot 3 PCI-E x8 OPROM	This setting enables/disables the PCI-E Slot OPROM option. Options include Disabled, Legacy and EFI.
On-board Video OPROM	Use this setting to control the execution of UEFI and Legacy Video OPROM on your system. Options include Disabled, Legacy or EFI .
On-board LAN 1 OPROM	This setting enables or disables On-board LAN 1 Option ROM. Options include Disabled, Legacy and EFI.
On-board LAN 2 OPROM	This setting enables or disables On-board LAN 2 Option ROM. Options include Disabled , Legacy and EFI

Table 5-9. PCIe/PCI/PnP Configuration Sub-menu (Continued)

Menu Option	Description
▶ Network Stack Configuration	Use this submenu to configure network stack settings.
Network Stack	This setting allows you to Enable or Disable UEFI Network Stack for your system. If disabled, the boot option for UEFI Network Stack will not be created.
Ipv4 PXE Support	This setting allows you to Enable or Disable Ipv4 PXE support for your system. If disabled, the boot option for Ipv4 PXE Support will not be created.
Ipv4 HTTP Support	This setting allows you to Enable or Disable Ipv4 HTTP support for your system. If disabled, the boot option for Ipv4 HTTP Support will not be created.
Ipv6 PXE Support	This setting allows you to Enable or Disable Ipv6 PXE Support for your system. If disabled, the boot option for Ipv4 PXE Support will not be created.
Ipv6 HTTP Support	This setting allows you to Enable or Disable Ipv6 HTTP Support for your system. If disabled, the boot option for Ipv6 HTTP Support will not be created.
PXE Boot Wait Time	This sets the wait time in seconds for you to press the ESC key in order to abort the PXE boot for your system. Default is 0 , use your system's keyboard's keypad to specify the number.
Media Detect Count	This sets the number of times the presence of media will be checked for your system. Default is 1 , use your system's keyboard's keypad to specify the number.

Table 5-10. SuperIO Device Configuration Sub-menu

Menu Option	Description
Super IO Chip	This static display shows the name of the Super IO chip installed for your system.
► Serial Port 1/2 Configuration	This sub-menu allows the user the configure settings of Serial Port 1 or Serial Port 2.
Serial Port	Select Enabled to enable the a selected On-board serial port. The options are Enabled and Disabled.
Device Settings	This displays a static display of the status of a serial part specified by the user.
Change Settings	This feature specifies the base I/O port address and the Interrupt Request address of a serial port specified by the user. Select Auto to allow the BIOS to automatically assign the base I/O and IRQ address. The options for Serial Port 1 are Auto , (IO=3F8h; IRQ=4), (IO=3F8h; IRQ=3, 4, 5, 6, 7, 9, 10, 11, 12), (IO=2F8h; IRQ=3, 4, 5, 6, 7, 9, 10, 11, 12), (IO=3E8h; IRQ=3, 4, 5, 6, 7, 9, 10, 11, 12) and (IO=2E8h; IRQ=3, 4, 5, 6, 7, 9, 10, 11, 12). The options for Serial Port 2 are Auto , (IO=2F8h; IRQ=3), (IO=3F8h; IRQ=3, 4, 5, 6, 7, 9, 10, 11, 12), (IO=2F8h; IRQ=3, 4, 5, 6, 7, 9, 10, 11, 12), (IO=3E8h; IRQ=3, 4, 5, 6, 7, 9, 10, 11, 12) and (IO=2E8h; IRQ=3, 4, 5, 6, 7, 9, 10, 11, 12).
Serial Port 2 Attribute (Available for Serial Port 2 only)	This feature specifies the attribute of Serial Port 1. The options are SOL and COM.

Table 5-11. Serial Port Console Redirection Sub-menu

Menu Option	Description
COM1 Console Redirection, COM2/SOL Console Redirection Sub-menus	
Console Redirection	Select Enabled to enable console redirection support for a serial port specified by the user. The options are Enabled and Disabled .
► Console Redirection Settings	This feature allows the user to specify how the host computer will exchange data with the client computer, which is the remote computer used by the user.
Terminal Type	This feature allows the user to select the target terminal emulation type for Console Redirection. Select VT100 to use the ASCII Character set. Select VT100+ to add color and function key support. Select ANSI to use the Extended ASCII Character Set. Select VT-UTF8 to use UTF8 encoding to map Unicode characters into one or more bytes. The options are ANSI, VT100, VT100+ , and VT-UTF8.
Bits Per second	Use this feature to set the transmission speed for a serial port used in Console Redirection. Make sure that the same speed is used in the host computer and the client computer. A lower transmission speed may be required for long and busy lines. The options are 9600, 19200, 38400, 57600 and 115200 (bits per second).
Data Bits	Use this feature to set the data transmission size for Console Redirection. The options are 7 Bits and 8 Bits .

Table 5-11. Serial Port Console Redirection Sub-menu (Continued)

Menu Option	Description
Parity	A parity bit can be sent along with regular data bits to detect data transmission errors. Select Even if the parity bit is set to 0, and the number of 1's in data bits is even. Select Odd if the parity bit is set to 0, and the number of 1's in data bits is odd. Select None if you do not want to send a parity bit with your data bits in transmission. Select Mark to add a mark as a parity bit to be sent along with the data bits. Select Space to add a Space as a parity bit to be sent with your data bits. The options are None , Even, Odd, Mark and Space.
Stop Bits	A stop bit indicates the end of a serial data packet. Select 1 Stop Bit for standard serial data communication. Select 2 Stop Bits if slower devices are used. The options are 1 and 2 .
Flow Control	Use this feature to set the flow control for Console Redirection to prevent data loss caused by buffer overflow. Send a "Stop" signal to stop sending data when the receiving buffer is full. Send a "Start" signal to start sending data when the receiving buffer is empty. The options are None and Hardware RTS/CTS.
VT-UTF8 Combo Key Support	Select Enabled to enable VT-UTF8 Combination Key support for ANSI/VT100 terminals. The options are Enabled and Disabled.
Recorder Mode	Select Enabled to capture the data displayed on a terminal and send it as text messages to a remote server. The options are Disabled and Enabled.
Resolution 100x31	Select Enabled for extended-terminal resolution support. The options are Disabled and Enabled .
Legacy OS Redirection Resolution	Use this feature to select the number of rows and columns used in Console Redirection for legacy OS support. The options are 80x24 and 80x25 .
Putty KeyPad	This feature selects the settings for Function Keys and KeyPad used for Putty, which is a terminal emulator designed for the Windows OS. The options are VT100 , LINUX, XTERMR6, SC0, ESCN, and VT400.
Redirection After BIOS Post	Use this feature to enable or disable legacy console redirection after BIOS POST. When set to Bootloader, legacy console redirection is disabled before booting the OS. When set to Always Enable, legacy console redirection remains enabled when booting the OS. The options are Always Enable and Bootloader.
Legacy Console Redirection Sub-menu	
Legacy Serial Redirection Port	Use this setting to select a COM port to display redirection of Legacy OS and Legacy OPROM messages. Options include COM1 Console Redirection or COM2/SOL Console Redirection.
Serial Port for Out-of-Band Management/Windows Emergency Management Services (EMS)	
Console Redirection (for EMS)	Select Enabled to use a COM Port selected by the user for Console Redirection. The options are Enabled and Disabled .
► Console Redirection Settings (for EMS)	This feature allows the user to specify how the host computer will exchange data with the client computer, which is the remote computer used by the user.
Out-of-Band Management Port	The feature selects a serial port used by the Microsoft Windows Emergency Management Services (EMS) to communicate with a remote server. The options are COM1 Console Redirection and COM2/SOL Console Redirection.

Table 5-11. Serial Port Console Redirection Sub-menu (Continued)

Menu Option	Description
Terminal Type	This feature allows the user to select the target terminal emulation type for Console Redirection. Select VT100 to use the ASCII character set. Select VT100+ to add color and function key support. Select ANSI to use the extended ASCII character set. Select VT-UTF8 to use UTF8 encoding to map Unicode characters into one or more bytes. The options are ANSI, VT100, VT100+, and VT-UTF8 .
Bits Per Second	This item sets the transmission speed for a serial port used in Console Redirection. Make sure that the same speed is used in the host computer and the client computer. A lower transmission speed may be required for long and busy lines. The options are 9600, 19200, 57600, and 115200 (bits per second).
Flow Control	This feature allows the user to set the flow control for Console Redirection to prevent data loss caused by buffer overflow. Send a "Stop" signal to stop sending data when the receiving buffer is full. Send a "Start" signal to start sending data when the receiving buffer is empty. The options are None , Hardware RTS/CTS, and Software Xon/Xoff.
Data Bits, Parity, Stop Bits	The status of each item above is displayed.

Table 5-12. ACPI Settings Sub-menu

Menu Option	Description
NUMA	Use this setting to Enable or Disable NUMA.
WHEA Support	This feature Enables the Windows Hardware Error Architecture (WHEA) support for the Windows 2008 (or a later vision) operating system. The options are Enabled and Disabled.
High Precision Timer	Select Enabled to activate the High Performance Event Timer (HPET) that produces periodic interrupts at a much higher frequency than a Real-time Clock (RTC) does in synchronizing multimedia streams, providing smooth playback and reducing the dependency on other timestamp calculation devices, such as an x86 RDTSC Instruction embedded in the CPU. The High Performance Event Timer is used to replace the 8254 Programmable Interval Timer. The options are Enabled and Disabled.

Table 5-13. Trusted Computing Settings Sub-menu

Menu Option	Description
Device Select	Use this setting to select the TPM device support and restriction to be used. Options are described below: <ul style="list-style-type: none"> • TPM 1.2 – This option restricts support to TPM 1.2 devices. • TPM 2.0 – This option restricts support to TPM 2.0 devices. • Auto – This option will support both with the default set to TPM 2.0 devices. If TPM 2.0 is not found, then TPM 1.2 devices will be enumerated. Default for this setting is the Auto option.
TXT Support	This setting will Enable or Disable TXT support.

Table 5-14. Intel(R) Virtual RAID on CPU Settings Sub-menu

Menu Option	Description
	Use this menu if you have RAID volumes or Intel VMD Controllers on the system to configure your Intel Virtual RAID on CPU settings. Otherwise this menu is blank.

5-6 Event Logs Setup

Figure 5-3. BIOS Setup Screen

Table 5-15. Event Logs Menu

Menu Option	Description
▶Change SMBIOS Event Log Settings	This sub-menu allows you to change the SMBIOS Event Log configuration settings.
SMBIOS Event Log	Change this setting to enable or disable all features of the SMBIOS Event Logging during system boot. The options are Enabled and Disabled .
Erase Event Log	If No is selected, data stored in the event log will not be erased. Select Yes, Next Reset, data in the event log will be erased upon next system reboot. Select Yes, Every Reset, data in the event log will be erased upon every system reboot. The options are No , Yes, Next reset, and Yes, Every reset.
When Log is Full	Select Erase Immediately for all messages to be automatically erased from the event log when the event log memory is full. The options are Do Nothing and Erase Immediately.
Log System Boot Event	This option toggles the System Boot Event logging to enabled or disabled. The options are Disabled and Enabled.
MECI	The Multiple Event Count Increment (MECI) counter counts the number of occurrences that a duplicate event must happen before the MECI counter is incremented. This is a numeric value. The default value is 1 .
METW	The Multiple Event Time Window (METW) defines number of minutes must pass between duplicate log events before MECI is incremented. This is in minutes, from 0 to 99. The default value is 60 .
Log OEM Codes	Use this setting to Enable or Disable the logging of EFI Status codes as OEM codes (if not already converted to legacy).
Convert OEM Codes	Use this setting to Enable or Disable the converting of EFI Status Codes to Standard SMBIOS types (not all may be translated).
▶View SMBIOS Event Log	This section displays the contents of the SMBIOS Event Log. It provides a date, time, error code and severity with a brief description of each event.

5-7 IPMI Setup

Figure 5-4. BIOS Setup Screen

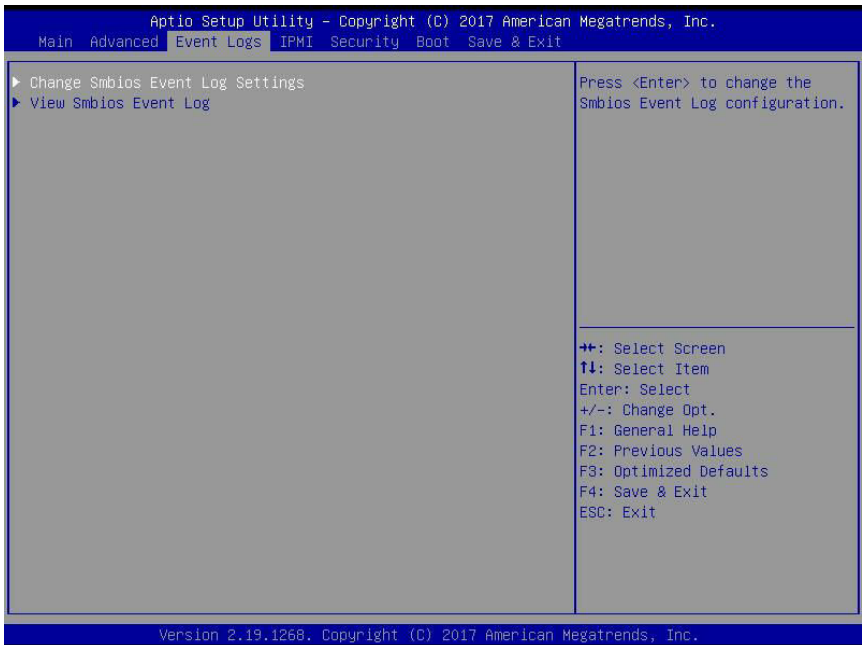
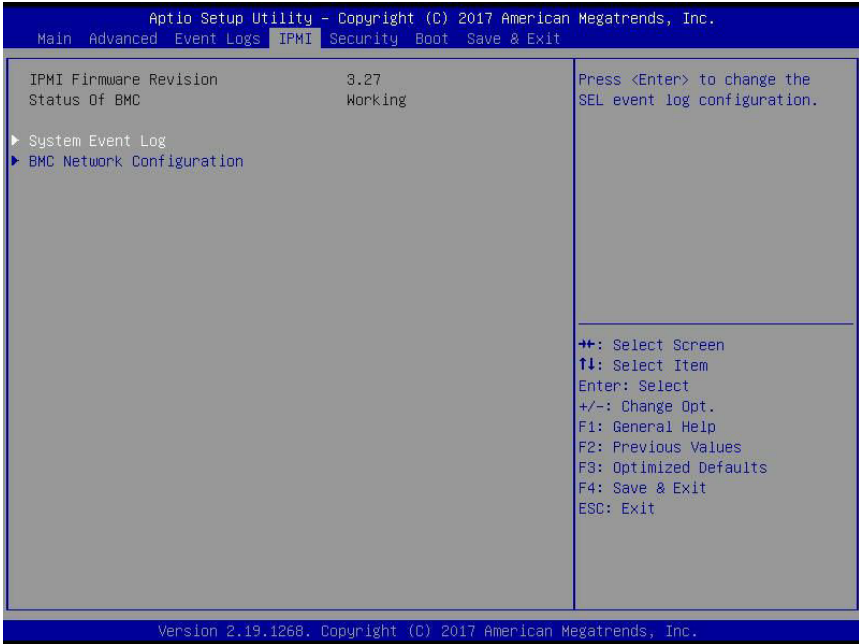
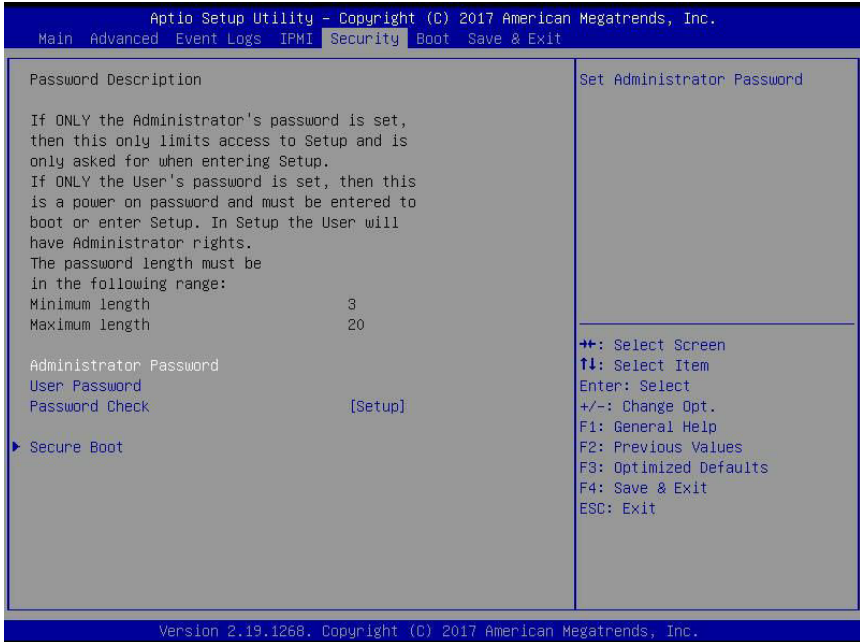

Table 5-16. IPMI Menu

Menu Option	Description
IPMI Information	IPMI Firmware Revision and IPMI Status information are statically displayed at the top of this menu.
► System Event Log	Selecting this sub-menu displays settings for changing the SEL Event Log configuration. Note: all values changed here do not take effect until the system is restarted.
SEL Components	Change this setting to Enable or Disable all features of the System Event Logging during boot-up.
Erase SEL	Use this setting for erasing the SEL. Options are No , Yes On Next Reset and Yes On Every Reset.
When SEL is Full	Use this setting to choose options for reactions to a full SEL. Options include Do Nothing and Erase Immediately.
Log EFI Status Codes	Use this setting to Enable or Disable logging of EFI status codes, log only error codes or only progress codes
► BMC Network Configuration	Use this sub-menu to configure BMC network parameters.
BMC Network Configuration Information	The sub-menu contains static display information for the Station IP Address, Subnet Mask, Station MAC Address and Gateway IP Address.
Update IPMI LAN Configuration	Specify Yes or No for the BIOS to use this setting for IPMI in the next boot-up.

5-8 Security

Figure 5-5. BIOS Setup Screen



Choose **Security** from the BIOS Setup main menu with the arrow keys to bring up the SECURITY SETUP menu. Security setting options are displayed by highlighting the setting using the arrow keys and pressing <ENTER>. All Security BIOS settings are described in [Table 5-17](#) below.

Table 5-17. Security Menu Options

Menu Option	Description
Administrator Password	This allows you to create an administrator password for the system.
User Password	This allows you to create user password for the system.
Password Check	Use this setting to specify when to do a password check. Options include checking the password while invoking Setup , or Always when invoking setup as well as on each boot.
► Secure Boot	This submenu allows you to customize the Secure Boot settings.
Attempt Secure Boot	This setting allows you to Enable or Disable Secure Boot activation when the Platform Key (PK) is enrolled. System Mode is User/Deployed, and the CSM function is disabled.

Table 5-17. Security Menu Options (Continued)

Menu Option	Description
Secure Boot Mode	This setting specifies the Secure Boot Mode used. Options include Standard and Custom . In Custom mode, Secure Boot variables can be configured without authentication.
CSM Support	Use this setting to Enable or Disable CSM support for your system.
▶Key Management	Use this submenu to modify boot policy variables without full authentication.
Provision Factory Defaults	This setting allows you to provision the factory default Secure Boot Keys when the system is in Setup Mode. Options include Enabled and Disabled .
Install Factory Default Keys	Use this setting to force the system to User Mode, and install all factory default keys. Pressing the Enter keyboard key will bring up Yes or No dialog.
Enroll EFI Image	This setting allows the image to run in Secure Boot Mode. Pressing the Enter keyboard key will bring up a field for entering in a path to enroll the SHA256 hash of the binary into the Authorized Signature Database (db).
Platform Key (PK)	For all of these features, enroll factory defaults or load certificates from a file.
Key Exchange Keys	
Authorized Signatures	
Forbidden Signatures	
Authorized Timestamps	
OsRecovery Signatures	

5-9 Boot

Figure 5-6. BIOS Setup Screen

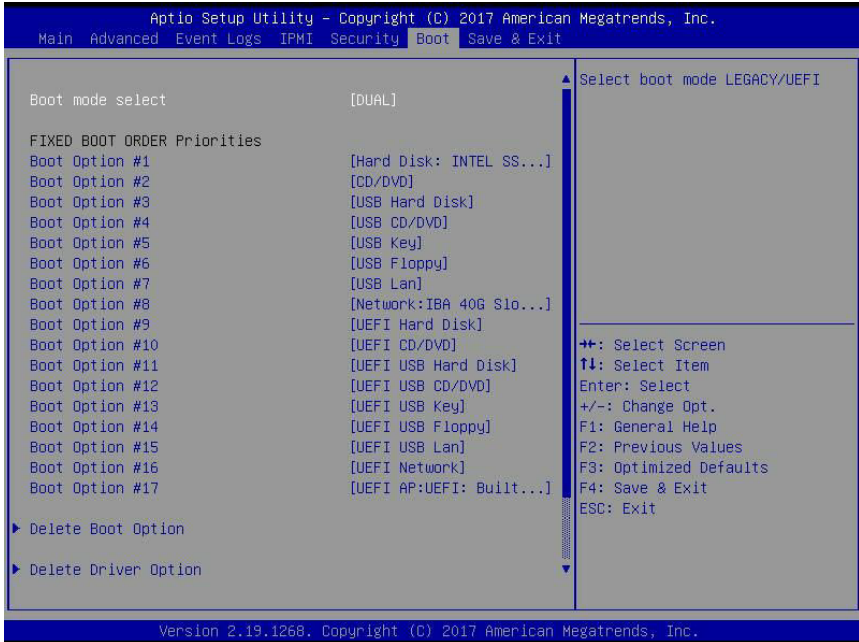

Choose **Boot** from the 256 Mb SPI Flash EEPROM with AMI® BIOS Setup Utility main menu with the arrow keys to bring up the BOOT SETUP menu. Security setting options are displayed by highlighting the setting using the arrow keys and pressing <ENTER>. All Security BIOS settings are described in [Table 5-18](#) below.

Table 5-18. Boot Setup Menu Options

Menu Option	Description
Boot Mode Select	This setting allows you to select the boot mode to use. Options include Legacy, UEFI or Dual .
Boot Priority Options 1 ~ 17	This feature allows you to specify the sequence of priority for the boot device (such as hard disk drives, USB devices, CD-ROM drives, Network drives and so on). The menu options are for 1st Boot Device, 2nd Boot Device and 3rd Boot device. Each numbered boot device can be set to a specific device installed in your system or to Disabled. NOTE: A device enclosed in parenthesis has been disabled in the corresponding type menu.
▶Delete Boot Option	This sub-menu allows you to remove an EFI boot option form the boot order.
▶Add New Driver Option	Use this submenu to add a new EFI driver option to the driver order.
Add driver option	Selecting this option brings up a field for entering a name for a new driver option.
Path for driver option	Selecting this option brings up a field for entering a path to the driver option in the format fsx:\path\filename.efi.
Create	After specifying the driver option name and path select this option to create it.
▶Delete Driver Option	This sub-menu allows you to remove an EFI driver option form the boot order.
▶UEFI Hard Disk Drive BBS Priorities	Use this submenu to specify the Boot Device Priority sequence from the available UEFI Hard Disk Drives in the system.
▶Hard Disk Drive BBS Priorities	Use this submenu to specify the Boot Device Priority sequence from the available Hard Disk Drives in the system.
▶Network Device BBS Priorities	This sub-menu allows you to set the order of the legacy devices in this group for setting the boot order.

5-10 Save & Exit

Figure 5-7. BIOS Setup Screen

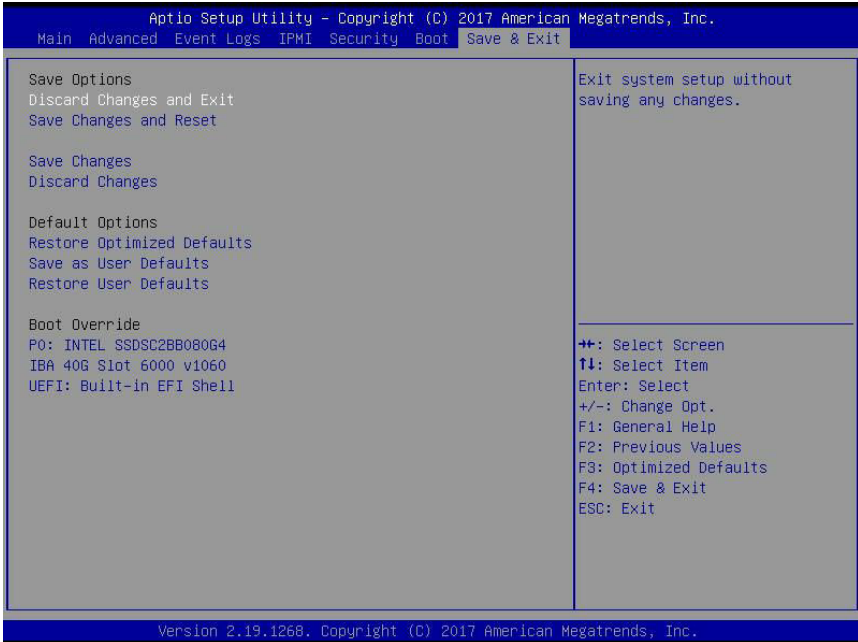

Choose **SAVE & EXIT** from the 256 Mb SPI Flash EEPROM with AMI® BIOS BIOS Setup Utility main menu with the arrow keys to display the **SAVE & EXIT SETUP** menu. All Exit BIOS settings are described in [Table 5-19](#) below.

Table 5-19. Exit Menu Options

Menu Option	Description
Discard Changes and Exit	Highlight this item and hit <ENTER> to exit the BIOS Setup utility without saving any changes you may have made. Any changes you have made to the BIOS Setup will not take effect upon system bootup.
Save Changes and Reset	Highlight this item and hit <ENTER> to save any changes you made and to exit the BIOS Setup utility. The system will reboot and implement the changes you have made to the BIOS Setup.
Save Changes	Highlight this item and hit <ENTER> to save changes done so far to any of the setup options.
Discard Changes	Highlight this item and hit <ENTER> to discard (cancel) any changes you made. You will remain in the Setup utility.
Restore Optimized Defaults	Highlight this item and hit <ENTER> to load the default settings for all items in the BIOS Setup. These are the safest settings to use and are designed for maximum system performance, but may not work best for all computer applications.
Save as Users Defaults	Highlight this item and hit <ENTER> to save changes done so far as user defaults.
Restore User Defaults	Highlight this item and hit <ENTER> to restore the user defaults to all the setup options.
Boot Override	For each boot device you have the option of saving the configuration for it and exiting.

Appendix A

Updating BIOS Using KVM Console

Use the following procedure to update a module BIOS using the KVM console software.

Updating the BIOS Using the KVM Console

1. Click on the graphic in the SYSTEM -> SYSTEM INFORMATION screen to launch the KVM Console window as shown in [Figure A-1](#).

Alternately, you may go to the CONFIGURATION -> CONSOLE REDIRECTION screen ([Figure A-2](#)) and press the LAUNCH CONSOLE button to bring up the KVM Console window.

Figure A-1. System Information Remote Console Preview Graphic



Figure A-2. Console Redirection Screen

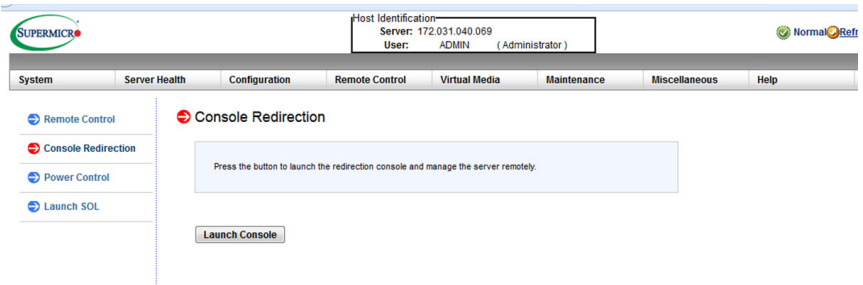

2. In the KVM Console window, click on the VIRTUAL STORAGE menu option from the VIRTUAL MEDIA menu (Figure A-3). The VIRTUAL STORAGE window will be displayed (Figure A-4).

Figure A-3. KVM Console Window

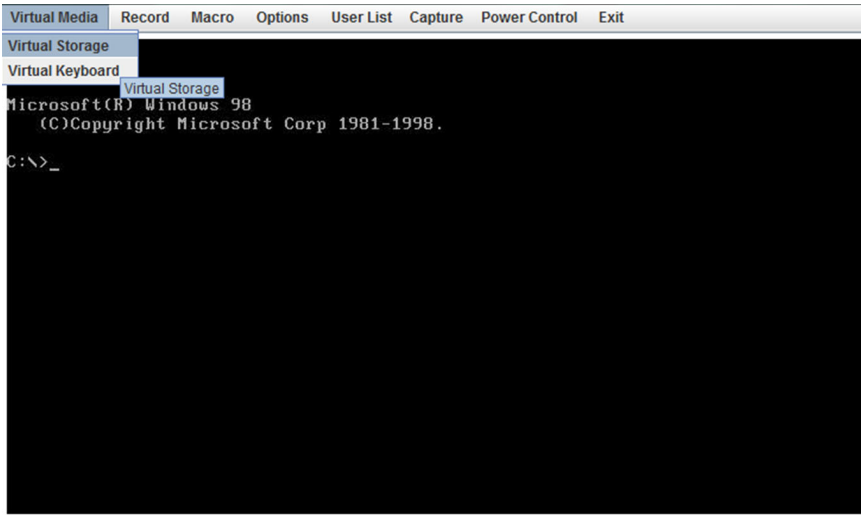
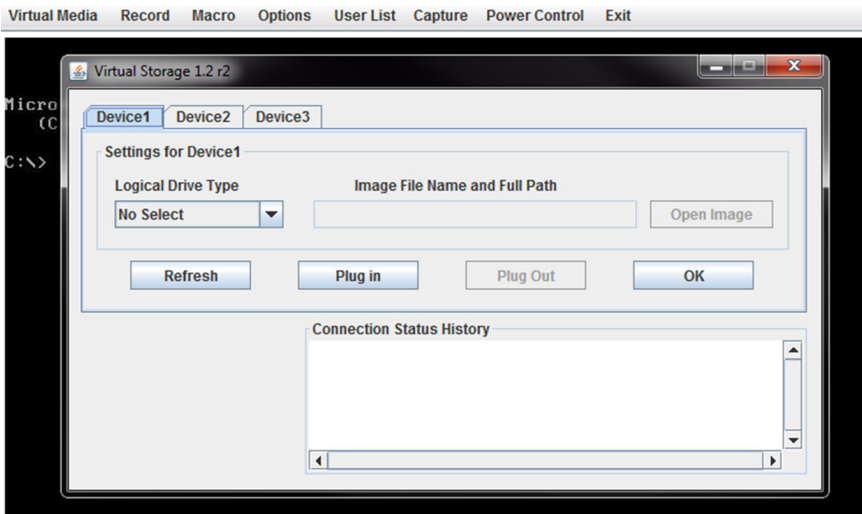
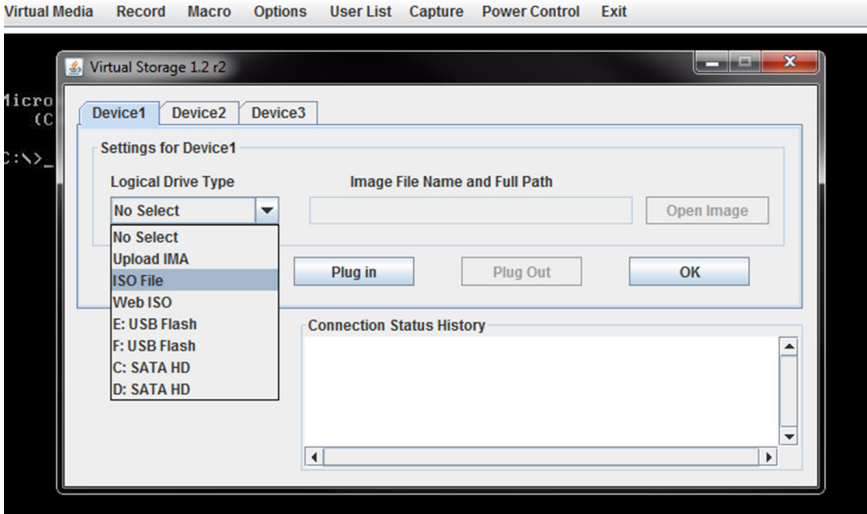

Figure A-4. Virtual Storage Window



- Under the DEVICE 1 tab of the VIRTUAL STORAGE window, select **ISO File** from the LOGICAL DRIVE TYPE menu if you wish to mount an ISO file (Figure A-5).

Figure A-5. Selecting ISO File to Mount an ISO File



- Browse for the ISO file on your local disk that contains the BIOS file and flash utility (Figure A-6). Press the OPEN button to select it.

Figure A-6. Locating the ISO File

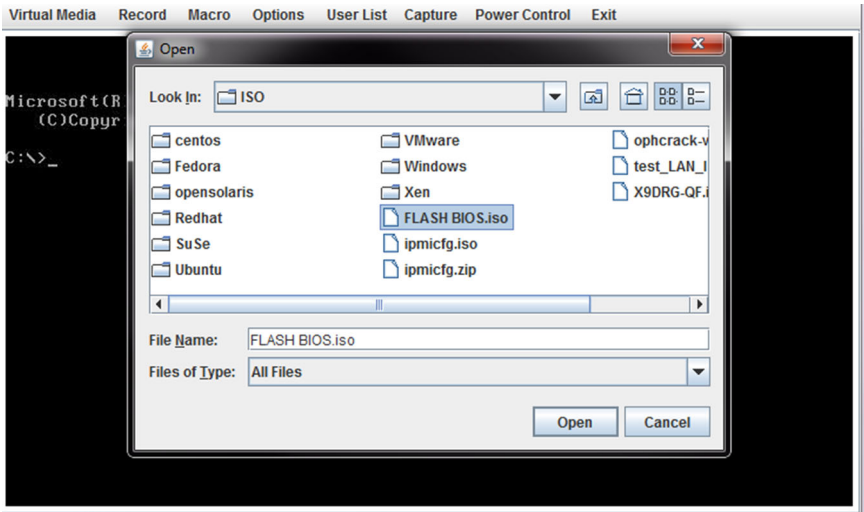

5. After you have selected the ISO file, press the Plug In button, then the OK button to exit the VIRTUAL STORAGE window (Figure A-7). Skip ahead to [step 8](#).

Figure A-7. Pressing the Plug In and OK Buttons for an ISO File

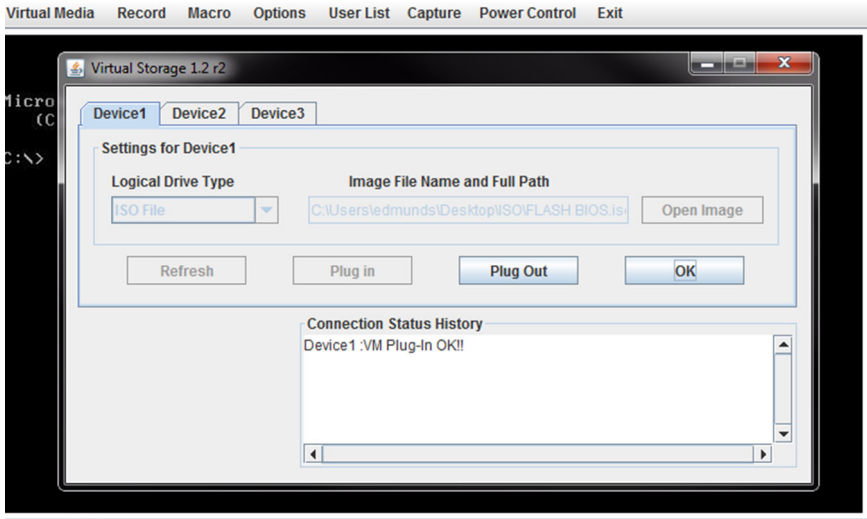

-
6. If you wish instead to download the BIOS update from a USB Flash drive, then insert the flash drive into your system and select it from the Logical Drive Type menu (Figure A-8).

Figure A-8. Selecting a USB Flash Drive

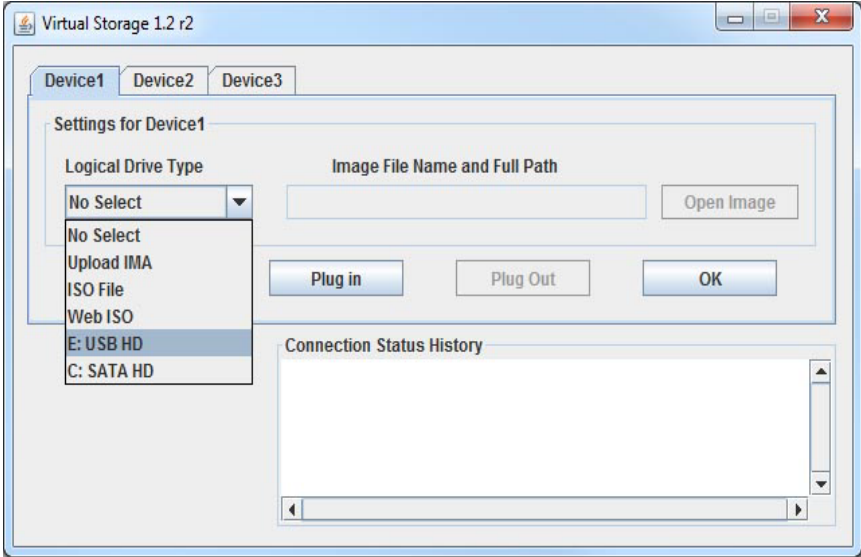

7. After you have selected the USB flash drive file, press the Plug In button, then the OK button to exit the VIRTUAL STORAGE window (Figure A-9).

Figure A-9. Pressing the Plug In and OK Buttons for an USB Flash Drive File

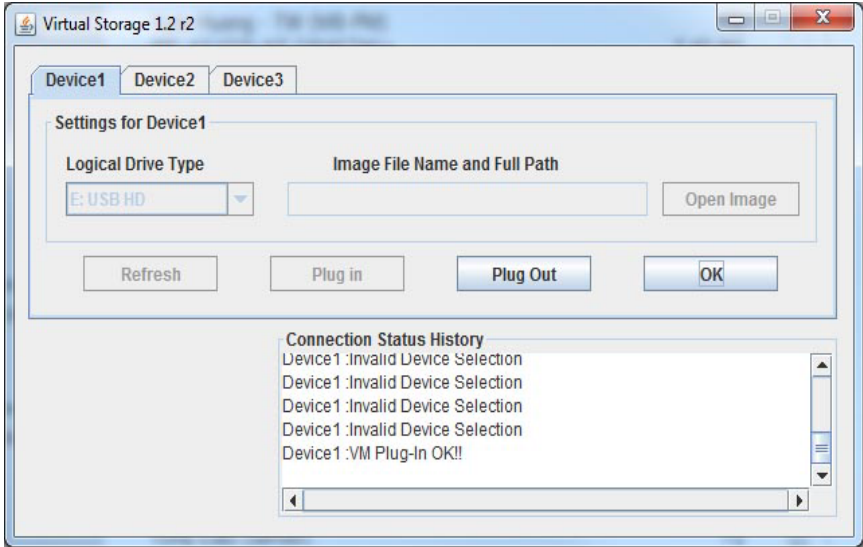

-
-
8. Reboot the MicroBlade by selecting the POWER CONTROL -> SET POWER RESET menu option from the KVM CONSOLE window. If the MicroBlade is not powered on yet, please select SET POWER ON from the menu ([Figure A-10](#)).

Figure A-10. Selecting Set Power Reset

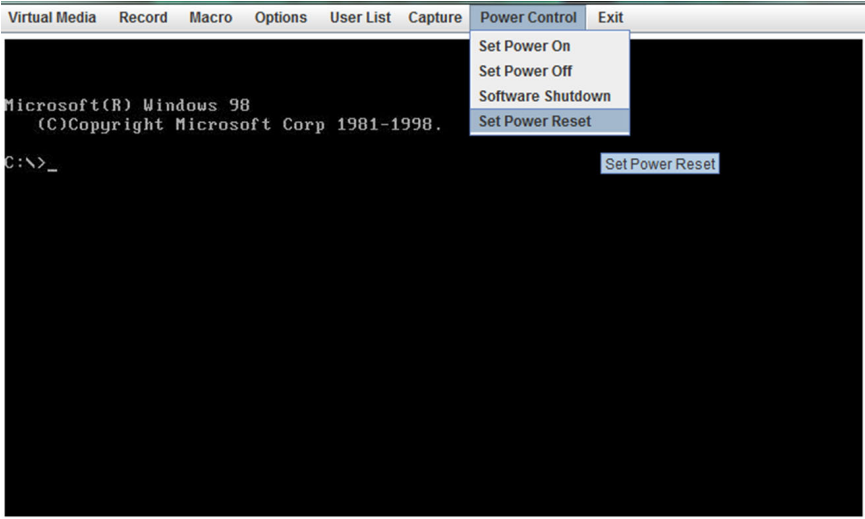

When the system powers up, press your keyboard's **F11** key in order to boot into the INVOKE BOOTABLE DEVICES LIST. From this list, select the **ATEN Virtual CDROM YS0J** command. Your MicroBlade will now boot up into mounting the ISO file which contains the new BIOS file and flash utility (Figure A-11).

Figure A-11. Bootable Devices List

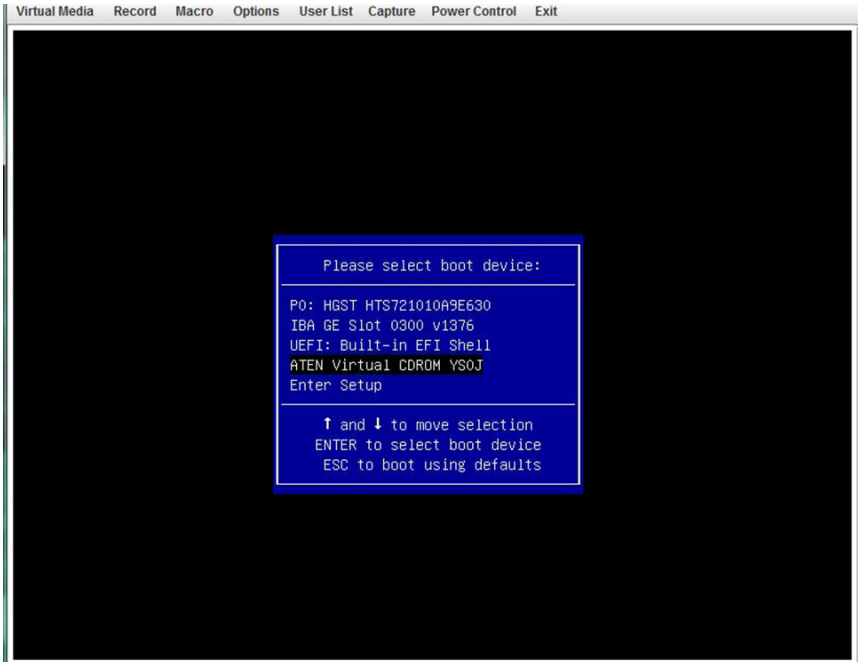

-
9. Close the KVM CONSOLE window, or go to the Virtual Storage window (see [step 2](#)) and click on **Plug Out**, this will remove mounting of the ISO file ([Figure A-12](#)).

Figure A-12. Clicking Plug Out in the Virtual Storage Window

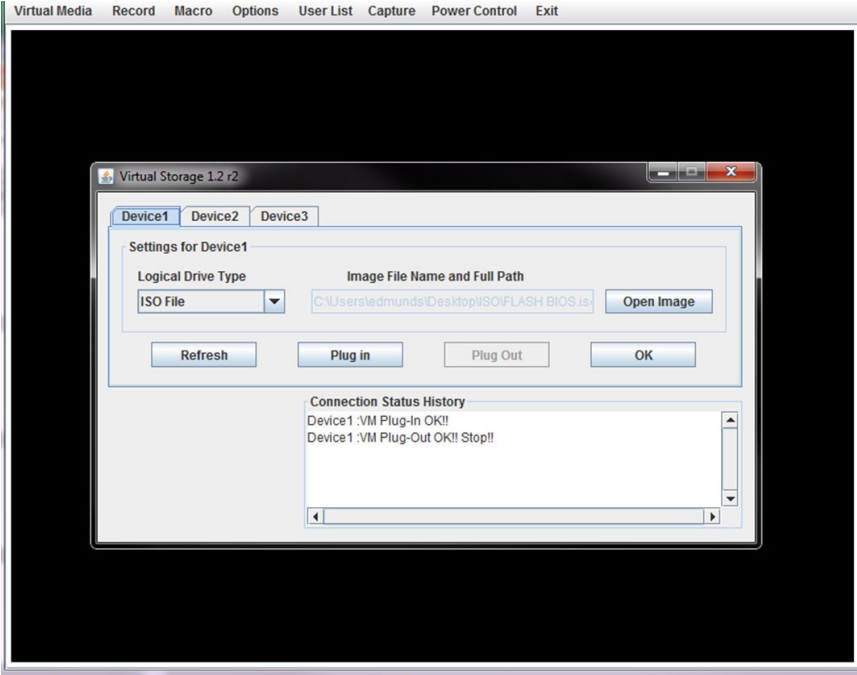

Disclaimer

The products sold by Supermicro are not intended for and will not be used in life support systems, medical equipment, nuclear facilities or systems, aircraft, aircraft devices, aircraft/emergency communication devices or other critical systems whose failure to perform be reasonably expected to result in significant injury or loss of life or catastrophic property damage. Accordingly, Supermicro disclaims any and all liability, and should buyer use or sell such products for use in such ultra-hazardous applications, it does so entirely at its own risk. Furthermore, buyer agrees to fully indemnify, defend and hold Supermicro harmless for and against any and all claims, demands, actions, litigation, and proceedings of any kind arising out of or related to such ultra-hazardous use or sale.

Appendix A

Specifications and Compliance

Operating Environment

Operating Temperature: 10° to 35° C (50° to 95° F)

Non-operating Temperature: -40° to 70° C (-40° to 158° F)

Operating Relative Humidity: 8% to 90% (non-condensing)

Non-operating Relative Humidity: 5% to 95% (non-condensing)

Regulatory Compliance

FCC, ICES, CE, VCCI, RCM, NRTL, CB

Applied Directives, Standards

EMC/EMI: 2014/30/EU (EMC Directive)

FCC Part 15

ICES-003

VCCI 32-1

AS/NZS CISPR 32

EN55032

EN55035

CISPR 24

EN 61000-3-2

EN 61000-3-3

EN 61000-4-2

EN 61000-4-3

EN 61000-4-4

EN 61000-4-5

EN 61000-4-6

EN 61000-4-8

EN 61000-4-11

Green Environment:

2011/65/EU (RoHS Directive)

EC 1907/2006 (REACH)

2012/19/EU (WEEE Directive)

Product Safety: 2014/35/EU (LVD Directive)

UL/CSA 60950-1, 62368-1 (USA and Canada)

IEC/EN 60950-1, 62368-1

Perchlorate Warnings

California Best Management Practices Regulations for Perchlorate Materials: This Perchlorate warning applies only to products containing CR (Manganese Dioxide) Lithium coin cells. "Perchlorate Material-special handling may apply. See www.dtsc.ca.gov/hazardouswaste/perchlorate"

General Data Center Environmental Specifications

Particulate contamination specifications

Air filtration: Data centers must be kept clean to Class 8 of ISO 14644-1 (ISO 2015). The air entering the data center should be filtered with a MERV 11 filter or better. The air within the data center should be continuously filtered with a MERV 8 filter or better.

Conductive dust: Air should be free fo conductive dust, zinc whiskers, or other conductive particles.

Corrosive dust: Air should be free of corrosive dust.

Gaseous* contamination specifications

Copper coupon corrosion rate: <300 Å/month per class G1 as defined by ANSI. ISA71.04-2013, reference by ASHRAE TC 9.9

Silver coupon corrosion rate: <200 Å/month per class G1 as defined by ANSI. ISA71.04-2013, reference by ASHRAE TC 9.9

*If testing with silver or copper coupons results in values less that 200 Å/month or 300 Å/month, respectively, then operating up to 70% relative humidity (RH) is acceptable. If the testing shows corrosion levels exceed these limits, then catalyst-type pollutants are probably present and RH should be driven to 50% or lower.