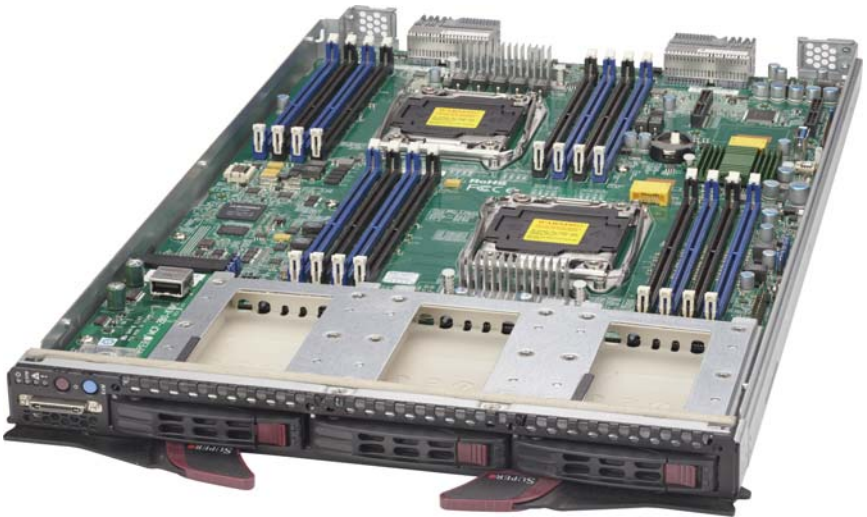




**SBI-7428R-T3  
SBI-7428R-T3N  
SuperBlade Module**



**User's Manual**

Revision 1.0b

The information in this User's Manual has been carefully reviewed and is believed to be accurate. The vendor assumes no responsibility for any inaccuracies that may be contained in this document, makes no commitment to update or to keep current the information in this manual, or to notify any person or organization of the updates. **Please Note: For the most up-to-date version of this manual, please see our web site at [www.supermicro.com](http://www.supermicro.com).**

Super Micro Computer, Inc. ("Supermicro") reserves the right to make changes to the product described in this manual at any time and without notice. This product, including software and documentation, is the property of Supermicro and/or its licensors, and is supplied only under a license. Any use or reproduction of this product is not allowed, except as expressly permitted by the terms of said license.

IN NO EVENT WILL SUPERMICRO BE LIABLE FOR DIRECT, INDIRECT, SPECIAL, INCIDENTAL, SPECULATIVE OR CONSEQUENTIAL DAMAGES ARISING FROM THE USE OR INABILITY TO USE THIS PRODUCT OR DOCUMENTATION, EVEN IF ADVISED OF THE POSSIBILITY OF SUCH DAMAGES. IN PARTICULAR, SUPERMICRO SHALL NOT HAVE LIABILITY FOR ANY HARDWARE, SOFTWARE, OR DATA STORED OR USED WITH THE PRODUCT, INCLUDING THE COSTS OF REPAIRING, REPLACING, INTEGRATING, INSTALLING OR RECOVERING SUCH HARDWARE, SOFTWARE, OR DATA.

Any disputes arising between manufacturer and customer shall be governed by the laws of Santa Clara County in the State of California, USA. The State of California, County of Santa Clara shall be the exclusive venue for the resolution of any such disputes. Super Micro's total liability for all claims will not exceed the price paid for the hardware product.

FCC Statement: This equipment has been tested and found to comply with the limits for a Class A digital device pursuant to Part 15 of the FCC Rules. These limits are designed to provide reasonable protection against harmful interference when the equipment is operated in a commercial environment. This equipment generates, uses, and can radiate radio frequency energy and, if not installed and used in accordance with the manufacturer's instruction manual, may cause harmful interference with radio communications. Operation of this equipment in a residential area is likely to cause harmful interference, in which case you will be required to correct the interference at your own expense.

California Best Management Practices Regulations for Perchlorate Materials: This Perchlorate warning applies only to products containing CR (Manganese Dioxide) Lithium coin cells. Perchlorate Material-special handling may apply. See [www.dtsc.ca.gov/hazardouswaste/perchlorate](http://www.dtsc.ca.gov/hazardouswaste/perchlorate) for further details.

**WARNING: HANDLING OF LEAD SOLDER MATERIALS USED IN THIS PRODUCT MAY EXPOSE YOU TO LEAD, A CHEMICAL KNOWN TO THE STATE OF CALIFORNIA TO CAUSE BIRTH DEFECTS AND OTHER REPRODUCTIVE HARM.**

Manual Revision 1.0b

Release Date: March 31, 2016

Unless you request and receive written permission from Super Micro Computer, Inc., you may not copy any part of this document.

Information in this document is subject to change without notice. Other products and companies referred to herein are trademarks or registered trademarks of their respective companies or mark holders.

Copyright © 2016 by Super Micro Computer, Inc.  
All rights reserved.

**Printed in the United States of America**

---

---

# Preface

## About this Manual

This manual is written for professional system integrators, Information Technology professionals, service personnel and technicians. It provides information for the installation and use of Supermicro's SBI-7428R-T3/T3N blade module. Installation and maintenance should be performed by experienced professionals only.

The only difference between the SBI-7428R-T3 and SBI-7428R-T3N blade modules is that the SBI-7428R-T3N supports NVMe drives and the SBI-7428R-T3 does not.

## Manual Organization

### Chapter 1: Introduction

The first chapter provides a checklist of the main components included with SBI-7428R-T3/T3N blade module and describes their main features.

### Chapter 2: System Safety

You should familiarize yourself with this chapter for a general overview of safety precautions that should be followed when installing and servicing SBI-7428R-T3/T3N blade module.

### Chapter 3: Setup and Installation

Refer to this chapter for details on installing the SBI-7428R-T3/T3N blade module into the SuperBlade<sup>®</sup> chassis. Other sections cover the installation and placement of memory modules and the installation of hard disk drives into the blade module.

### Chapter 4: Blade Module Features

This chapter covers features and component information about SBI-7428R-T3/T3N blade module. Included here are descriptions and information for mainboard components, connectors, LEDs and other features of the blade module.

### Chapter 5: RAID Setup Procedure

RAID setup and operations for SBI-7428R-T3/T3N blade module are covered in this chapter.

### Chapter 6: BIOS

BIOS setup is covered in this chapter for SBI-7428R-T3/T3N blade module.

### Appendix A: BIOS POST Codes

BIOS POST Codes for SBI-7428R-T3/T3N blade module are explained in this appendix.

## Notes

---

---

# Table of Contents

<b>Chapter 1 Introduction</b> .....	1-1
1-1 Overview.....	1-1
1-2 Product Checklist of Typical Components.....	1-1
1-3 Blade Module Features.....	1-2
Processors.....	1-2
Memory.....	1-2
Storage.....	1-3
NVMe.....	1-3
Density.....	1-3
1-4 Contacting Supermicro.....	1-5
<b>Chapter 2 Standardized Warning Statements</b> .....	2-1
2-1 About Standardized Warning Statements.....	2-1
Warning Definition.....	2-1
Installation Instructions.....	2-3
Circuit Breaker.....	2-4
Power Disconnection Warning.....	2-5
Equipment Installation.....	2-6
Restricted Area.....	2-7
Battery Handling.....	2-9
Redundant Power Supplies.....	2-10
Backplane Voltage.....	2-11
Comply with Local and National Electrical Codes.....	2-12
Product Disposal.....	2-13
Hot Swap Fan Warning.....	2-14
Power Cable and AC Adapter.....	2-15
<b>Chapter 3 Setup and Installation</b> .....	3-1
3-1 Overview.....	3-1
3-2 Installing Blade Modules.....	3-1
Powering Up a Blade Unit.....	3-1
Powering Down a Blade Unit.....	3-1
Removing a Blade Unit from the Enclosure.....	3-2
Removing/Replacing the Blade Cover.....	3-2
Installing a Blade Unit into the Enclosure.....	3-2
3-3 Processor Installation.....	3-4

3-4 Onboard Battery Installation .....	3-9
3-5 Memory Installation .....	3-9
Populating Memory Slots .....	3-9
DIMM Installation .....	3-11
3-6 Hard Disk Drive Installation .....	3-12
3-7 Installing the Operating System .....	3-13
Installing with an External USB CD-ROM Drive .....	3-13
Installing via PXE Boot .....	3-13
Installing via Virtual Media (Drive Redirection) .....	3-14
3-8 Management Software .....	3-14
3-9 Configuring and Setting up RAID .....	3-14
<b>Chapter 4 Blade Module Features .....</b>	<b>4-1</b>
4-1 Control Panel .....	4-2
Power Button .....	4-3
KVM Button .....	4-3
LED Indicators .....	4-3
KVM Connector .....	4-3
4-2 Mainboard .....	4-4
Jumpers .....	4-6
CMOS Clear .....	4-6
4-3 Blade Unit Components .....	4-7
Memory Support .....	4-8
Hard Disk Drives .....	4-8
<b>Chapter 5 RAID Setup Procedure .....</b>	<b>5-1</b>
5-1 RAID Configurations .....	5-1
5-2 Preparing for Setup .....	5-1
5-3 RAID Setup Procedure .....	5-2
<b>Chapter 6 BIOS .....</b>	<b>6-1</b>
6-1 Introduction .....	6-1
System BIOS .....	6-1
How To Change the Configuration Data .....	6-1
Starting the Setup Utility .....	6-1
6-2 BIOS Updates .....	6-2
Flashing BIOS .....	6-2
6-3 Running Setup .....	6-3
6-4 Main BIOS Setup .....	6-4

6-5 Advanced Setup .....	6-5
6-6 Event Logs Setup .....	6-18
6-7 IPMI Setup .....	6-19
6-8 Security .....	6-20
6-9 Boot .....	6-20
6-10 Save & Exit .....	6-21
<b>Appendix A BIOS POST Codes .....</b>	<b>A-1</b>
A-1 BIOS POST Messages .....	A-1
A-2 BIOS POST Codes .....	A-3
Recoverable POST Errors .....	A-4
Terminal POST Errors .....	A-4

## Notes

---

---

# Chapter 1

## Introduction

### 1-1 Overview

This user's manual covers the SBI-7428R-T3/T3N blade module. This blade module is a compact self-contained server that connects into a pre-cabled enclosure that provides power, cooling, management and networking functions. One enclosure for the SBI-7428R-T3/T3N blade module can hold fourteen blade units.

In this manual, "blade system" refers to the entire system (including the enclosure and blades units), "blade" or "blade unit" refers to a single blade module and "blade enclosure" is the chassis that the blades, power supplies and modules are housed within.

Please refer to our web site for information on operating systems that have been certified for use with the SuperBlade ([www.supermicro.com/products/superblade/](http://www.supermicro.com/products/superblade/)).

### 1-2 Product Checklist of Typical Components

Your blade module ships with its B10DRI mainboard already installed in its chassis. Memory, hard disk drives and the CPU must all be installed by the user after shipment. See [Chapter 3: "Setup and Installation" on page 3-1](#) for details on installation of these components.

Aside from the blade module unit itself, the following optional Mezzanine add-on cards (with Infiniband Switch) may be ordered for your blade module:

- AOC-IBH-X3QD
- AOC-IBH-X3QS
- AOC-XEH-iN2
- AOC-IBH-XDD
- AOC-IBH-XQD
- AOC-IBH-XQS
- AOC-IBH-XDS

See the [Supermicro website](#) and the *SuperBlade Network Modules User's Manual* on your SuperBlade system's CD-ROM for more details on these add-on cards.

## 1-3 Blade Module Features

**Table 1-1** lists the main features of the SBI-7428R-T3/T3N blade module. See the proceeding section for components typically included in a blade system and other optional components. Specific details for the SBI-7428R-T3/T3N blade module are found in **Chapter 4: "Blade Module Features"** on page 4-1.

**Table 1-1. SBI-7428R-T3/T3N Blade Module Specification Features**

Mainboard	B10DRI (proprietary form factor) Chassis Dimensions (HxWxD): 11.32"x 1.19" x18.9" (288-mm x 30.2-mm x 480-mm)
Processors	Dual or quad core Intel™ Xeon® E5-2600 V3/V4 series 2011-pin processors. Please refer to our web site for a complete listing of supported processors.
FSB Speed	QPI up to 9.6 GT/s
Chipset	Intel C612
Graphics Controller	Aspeed AST2400 BMC Graphics
BIOS	64 MB SPI Flash EEPROM with AMI® BIOS
Memory Capacity	Supports up to 512 GB memory in 32 GB, 16 GB, 8 GB or 4 GB VLP RDIMM size, 2400/2133/1866/1600 MHz speed SDRAM in sixteen (16) 288-pin DDR4 DIMM sockets
SATA Controller	Intel C612 on-chip controller for three Serial ATA drives
Hard Drive Bays	Includes three hot-swap drive bays for 2.5" Hot-swap HDD/SSD/NVMe SATA disk drives (RAID 0 and 1)

### Processors

The SBI-7428R-T3/T3N blade module supports dual 2011-pin (LGA 2011 Socket R3) Intel Xeon E5-2600 V3/V4 series processors.

Refer to the Supermicro web site for a complete listing of supported processors (<http://www.supermicro.com/products/superblade>). Please note that you will need to check the detailed specifications of a particular blade module for a list of the CPUs it supports.

Details on installation of the processor into the SBI-7428R-T3/T3N blade module are found in **Chapter 3: "Setup and Installation"** on page 3-1.

### Memory

The SBI-7428R-T3/T3N blade module has sixteen (16) 288-pin DDR4 DIMM sockets that can support up to 512 GB of 32 GB, 16 GB, 8 GB or 4 GB VLP RDIMM size, 2400/2133/1866/1600 MHz speed SDRAM. Memory is interleaved, which requires modules of the same size and speed to be installed in groups (of two or three).

Please refer to the Supermicro web site for a list of supported memory ([www.supermicro.com/products/superblade](http://www.supermicro.com/products/superblade)). The detailed specifications for a blade module will contain a link to a list of recommended memory sizes and manufacturers.

Details on installation of memory modules into the SBI-7428R-T3/T3N blade module are found in [Chapter 3: "Setup and Installation" on page 3-1](#).

## Storage

The SBI-7428R-T3/T3N blade module can have three 2.5" Hot-swap HDD/SSD/NVMe SATA (Serial ATA)/SSD hard disk drives in front-mounted easy removable carriers. Only the SBI-7428R-T3N blade module can support NVMe drives. See [Chapter 3: "Setup and Installation" on page 3-1](#) for storage installation details.

The SBI-7428R-T3/T3N blade module also has two SuperDOM ports for attaching SuperDOM drives to the serverboard. See <http://www.supermicro.com/products/nfo/satadom.cfm> for details on SuperDOM ports.

## NVMe

The NVMe Express ports available in the SBI-7428R-T3N blade module provide high-speed, low-latency connections directly from the CPU to NVMe Solid State drives (SSDs). This greatly increases SSD throughput and significantly reduces storage device latency by simplifying driver and software requirements resulting from the direct PCI-E interface between the CPU and the NVMe SSD drives.

## Density

A maximum of fourteen blade modules may be installed into a single blade enclosure. Each blade enclosure is a 7U form factor, so a standard 42U rack may accommodate up to six 14-blade enclosures with 84 blade modules, or the equivalent of 84 1U servers. With the inclusion of six CMM modules, twelve Gigabit Ethernet switches and six InfiniBand switches, this would occupy up to 108U space in a conventional 1U server configuration.

[Figure 1-1](#) displays a view of a full rack with six blade enclosures in it, each with fourteen blades to an enclosure.

**Figure 1-1. Full Rack of Blade Enclosures and Blade Servers**



## 1-4 Contacting Supermicro

### Headquarters

Address: Super Micro Computer, Inc.  
980 Rock Ave.  
San Jose, CA 95131 U.S.A.

Tel: +1 (408) 503-8000

Fax: +1 (408) 503-8008

Email: marketing@supermicro.com (General Information)  
support@supermicro.com (Technical Support)

Website: [www.supermicro.com](http://www.supermicro.com)

### Europe

Address: Super Micro Computer B.V.  
Het Sterrenbeeld 28, 5215 ML  
's-Hertogenbosch, The Netherlands

Tel: +31 (0) 73-6400390

Fax: +31 (0) 73-6416525

Email: sales@supermicro.nl (General Information)  
support@supermicro.nl (Technical Support)  
rma@supermicro.nl (Customer Support)

### Asia-Pacific

Address: Super Micro Computer, Inc.  
3F, No. 150, Jian 1st Rd.  
Zhonghe Dist., New Taipei City 23511  
Taiwan (R.O.C)

Tel: +886-(2) 8226-3990

Fax: +886-(2) 8226-3992

Website: [www.supermicro.com.tw](http://www.supermicro.com.tw)

Technical Support:

Email: support@supermicro.com.tw

## Notes

---

---

# Chapter 2

## Standardized Warning Statements

### 2-1 About Standardized Warning Statements

The following statements are industry standard warnings, provided to warn the user of situations which have the potential for bodily injury. Should you have questions or experience difficulty, contact Supermicro's Technical Support department for assistance. Only certified technicians should attempt to install or configure components.

Read this appendix in its entirety before installing or configuring components in the Supermicro chassis

These warnings may also be found on our web site at [http://www.supermicro.com/about/policies/safety\\_information.cfm](http://www.supermicro.com/about/policies/safety_information.cfm).

#### Warning Definition



##### Warning!

This warning symbol means danger. You are in a situation that could cause bodily injury. Before you work on any equipment, be aware of the hazards involved with electrical circuitry and be familiar with standard practices for preventing accidents.

##### 警告の定義

この警告サインは危険を意味します。

人身事故につながる可能性がありますので、いずれの機器でも動作させる前に、電気回路に含まれる危険性に注意して、標準的な事故防止策に精通して下さい。

此警告符号代表危險。

您正處於可能受到嚴重傷害的工作環境中。在您使用設備開始工作之前，必須充分意識到觸電的危險，並熟練掌握防止事故發生的標準工作程序。請根據每項警告結尾的聲明號碼找到此設備的安全性警告說明的翻譯文本。

此警告符號代表危險。

您正處於可能身體可能會受損傷的工作環境中。在您使用任何設備之前，請注意觸電的危險，並且要熟悉預防事故發生的標準工作程序。請依照每一注意事項後的號碼找到相關的翻譯說明內容。

## Warnung

### WICHTIGE SICHERHEITSHINWEISE

Dieses Warnsymbol bedeutet Gefahr. Sie befinden sich in einer Situation, die zu Verletzungen führen kann. Machen Sie sich vor der Arbeit mit Geräten mit den Gefahren elektrischer Schaltungen und den üblichen Verfahren zur Vorbeugung vor Unfällen vertraut. Suchen Sie mit der am Ende jeder Warnung angegebenen Anweisungsnummer nach der jeweiligen Übersetzung in den übersetzten Sicherheitshinweisen, die zusammen mit diesem Gerät ausgeliefert wurden.

BEWAHREN SIE DIESE HINWEISE GUT AUF.

### INSTRUCCIONES IMPORTANTES DE SEGURIDAD

Este símbolo de aviso indica peligro. Existe riesgo para su integridad física. Antes de manipular cualquier equipo, considere los riesgos de la corriente eléctrica y familiarícese con los procedimientos estándar de prevención de accidentes. Al final de cada advertencia encontrará el número que le ayudará a encontrar el texto traducido en el apartado de traducciones que acompaña a este dispositivo.

GUARDE ESTAS INSTRUCCIONES.

### IMPORTANTES INFORMATIONS DE SÉCURITÉ

Ce symbole d'avertissement indique un danger. Vous vous trouvez dans une situation pouvant entraîner des blessures ou des dommages corporels. Avant de travailler sur un équipement, soyez conscient des dangers liés aux circuits électriques et familiarisez-vous avec les procédures couramment utilisées pour éviter les accidents. Pour prendre connaissance des traductions des avertissements figurant dans les consignes de sécurité traduites qui accompagnent cet appareil, référez-vous au numéro de l'instruction situé à la fin de chaque avertissement.

CONSERVEZ CES INFORMATIONS.

## תקנתן הצהרות אזהרה

הצהרות הבאות הן אזהרות על פי תקני התעשייה, על מנת להזהיר את המשתמש מפני חבלה פיזית אפשרית. במידה ויש שאלות או היתקלות בבעיה כלשהי, יש ליצור קשר עם מחלקת תמיכה טכנית של סופרמיקרו. טכנאים מוסמכים בלבד רשאים להתקין או להגדיר את הרכיבים.

יש לקרוא את הנספח במלואו לפני התקנת או הגדרת הרכיבים במארזי סופרמיקרו.

تحذير! هذا الرمز يعني خطر انك في حالة يمكن أن تتسبب في اصابة جسدية .  
قبل أن تعمل على أي معدات، كن على علم بالمخاطر الناجمة عن الدوائر  
الكهربائية

وكن على دراية بالممارسات الوقائية لمنع وقوع أي حوادث  
استخدم رقم البيان المنصوص في نهاية كل تحذير للعثور ترجمتها

안전을 위한 주의사항

경고!

이 경고 기호는 위험이 있음을 알려 줍니다. 작업자의 신체에 부상을 야기 할 수 있는 상태에 있게 됩니다. 모든 장비에 대한 작업을 수행하기 전에 전기회로와 관련된 위험 요소들을 확인하시고 사전에 사고를 방지할 수 있도록 표준 작업절차를 준수해 주시기 바랍니다.

해당 번역문을 찾기 위해 각 경고의 마지막 부분에 제공된 경고문 번호를 참조하십시오

## **BELANGRIJKE VEILIGHEIDSINSTRUCTIES**

Dit waarschuwings symbool betekent gevaar. U verkeert in een situatie die lichamelijk letsel kan veroorzaken. Voordat u aan enige apparatuur gaat werken, dient u zich bewust te zijn van de bij een elektrische installatie betrokken risico's en dient u op de hoogte te zijn van de standaard procedures om ongelukken te voorkomen. Gebruik de nummers aan het eind van elke waarschuwing om deze te herleiden naar de desbetreffende locatie.

**BEWAAR DEZE INSTRUCTIES**

### **Installation Instructions**



#### **Warning!**

Read the installation instructions before connecting the system to the power source.

設置手順書

システムを電源に接続する前に、設置手順書をお読み下さい。

警告

将此系统连接电源前，请先阅读安装说明。

警告

將系統與電源連接前，請先閱讀安裝說明。

#### **Warnung**

Vor dem Anschließen des Systems an die Stromquelle die Installationsanweisungen lesen.

#### **¡Advertencia!**

Lea las instrucciones de instalación antes de conectar el sistema a la red de alimentación.

#### **Attention**

Avant de brancher le système sur la source d'alimentation, consulter les directives d'installation.

יש לקרוא את הוראות התקנה לפני חיבור המערכת למקור מתח.

اقرأ إرشادات التركيب قبل توصيل النظام إلى مصدر للطاقة

시스템을 전원에 연결하기 전에 설치 안내를 읽어주십시오.

### Waarschuwing

Raadpleeg de installatie-instructies voordat u het systeem op de voedingsbron aansluit.

### Circuit Breaker



#### Warning!

This product relies on the building's installation for short-circuit (overcurrent) protection. Ensure that the protective device is rated not greater than: 250 V, 20 A.

サーキット・ブレーカー

この製品は、短絡（過電流）保護装置がある建物での設置を前提としています。

保護装置の定格が 250 V、20 A を超えないことを確認下さい。

#### 警告

此产品的短路（过载电流）保护由建筑物的供电系统提供，确保短路保护设备的额定电流不大于 250V, 20A。

#### 警告

此產品的短路（過載電流）保護由建築物的供電系統提供，確保短路保護設備的額定電流不大於 250V, 20A。

### Warnung

Dieses Produkt ist darauf angewiesen, dass im Gebäude ein Kurzschluss- bzw. Überstromschutz installiert ist. Stellen Sie sicher, dass der Nennwert der Schutzvorrichtung nicht mehr als: 250 V, 20 A beträgt.

### ¡Advertencia!

Este equipo utiliza el sistema de protección contra cortocircuitos (o sobrecorrientes) del edificio. Asegúrese de que el dispositivo de protección no sea superior a: 250 V, 20 A.

### Attention

Pour ce qui est de la protection contre les courts-circuits (surtension), ce produit dépend de l'installation électrique du local. Vérifiez que le courant nominal du dispositif de protection n'est pas supérieur à :250 V, 20 A.

מוצר זה מסתמך על הגנה המותקנת במבנים למניעת קצר חשמלי. יש לוודא כי המכשיר המגן מפני הקצר החשמלי הוא לא יותר מ-250 V, 20 A

هذا المنتج يعتمد على معدات الحماية من الدوائر القصيرة التي تم تثبيتها في  
المبنى  
تأكد من أن تقييم الجهاز الوقائي ليس أكثر من: 20A, 250V

경고!

이 제품은 전원의 단락 (과전류) 방지에 대해서 전적으로 건물의 관련 설비에 의존합니다. 보호장치의 정격이 반드시 250V(볼트), 20A(암페어)를 초과하지 않도록 해야 합니다.

### Waarschuwing

Dit product is afhankelijk van de kortsluitbeveiliging (overspanning) van uw elektrische installatie. Controleer of het beveiligde apparaat niet groter gedimensioneerd is dan 220V, 20A.

### Power Disconnection Warning



#### Warning!

The system must be disconnected from all sources of power and the power cord removed from the power supply module(s) before accessing the chassis interior to install or remove system components.

#### 電源切斷の警告

システムコンポーネントの取り付けまたは取り外しのために、シャーシ内部にアクセスするには、

システムの電源はすべてのソースから切斷され、電源コードは電源モジュールから取り外す必要があります。

#### 警告

在你打开机箱并安装或移除内部器件前，必須將系統完全斷電，並移除電源線。

#### 警告

在您打開機殼安裝或移除內部元件前，必須將系統完全斷電，並移除電源線。

### Warnung

Das System muss von allen Quellen der Energie und vom Netzanschlusskabel getrennt sein, das von den Spg.Versorgungsteilmodulen entfernt wird, bevor es auf den Chassisinnenraum zurückgreift, um Systemsbestandteile anzubringen oder zu entfernen.

### ¡Advertencia!

El sistema debe ser disconnected de todas las fuentes de energía y del cable eléctrico quitado de los módulos de fuente de alimentación antes de tener acceso el interior del chasis para instalar o para quitar componentes de sistema.

### Attention

Le système doit être débranché de toutes les sources de puissance ainsi que de son cordon d'alimentation secteur avant d'accéder à l'intérieur du châssis pour installer ou enlever des composants de système.

## אזהרה מפני ניתוק חשמלי

### !אזהרה!

יש לנתק את המערכת מכל מקורות החשמל ויש להסיר את כבל החשמלי מהספק לפני גישה לחלק הפנימי של המארז לצורך התקנת או הסרת רכיבים.

يجب فصل النظام من جميع مصادر الطاقة وإزالة سلك الكهرباء من وحدة امداد الطاقة قبل

الوصول إلى المناطق الداخلية للهيكल لتثبيت أو إزالة مكونات الجهاز

경고!

시스템에 부품들을 장착하거나 제거하기 위해서는 새시 내부에 접근하기 전에 반드시 전원 공급장치로부터 연결되어있는 모든 전원과 전기코드를 분리해주어야 합니다.

### Waarschuwing

Voordat u toegang neemt tot het binnenwerk van de behuizing voor het installeren of verwijderen van systeem onderdelen, dient u alle spanningsbronnen en alle stroomkabels aangesloten op de voeding(en) van de behuizing te verwijderen.

## Equipment Installation



### Warning!

Only trained and qualified personnel should be allowed to install, replace, or service this equipment.

### 機器の設置

トレーニングを受け認定された人だけがこの装置の設置、交換、またはサービスを許可されています。

### 警告

只有经过培训且具有资格的人员才能进行此设备的安装、更换和维修。

### 警告

只有經過受訓且具資格人員才可安裝、更換與維修此設備。

**Warnung**

Das Installieren, Ersetzen oder Bedienen dieser Ausrüstung sollte nur geschultem, qualifiziertem Personal gestattet werden.

**¡Advertencia!**

Solamente el personal calificado debe instalar, reemplazar o utilizar este equipo.

**Attention**

Il est vivement recommandé de confier l'installation, le remplacement et la maintenance de ces équipements à des personnels qualifiés et expérimentés.

**אזהרה!**

צוות מוסמך בלבד רשאי להתקין, להחליף את הציוד או לתת שירות עבור הציוד.

يجب أن يسمح فقط للموظفين المؤهلين والمدربين لتكيب واستبدال أو خدمة هذا الجهاز  
경고!

훈련을 받고 공인된 기술자만이 이 장비의 설치, 교체 또는 서비스를 수행할 수 있습니다.

**Waarschuwing**

Deze apparatuur mag alleen worden geïnstalleerd, vervangen of hersteld door geschoold en gekwalificeerd personeel.

**Restricted Area**



**Warning!**

This unit is intended for installation in restricted access areas. A restricted access area can be accessed only through the use of a special tool, lock and key, or other means of security. (This warning does not apply to workstations).

**アクセス制限区域**

このユニットは、アクセス制限区域に設置されることを想定しています。

アクセス制限区域は、特別なツール、鍵と錠前、その他のセキュリティの手段を用いてのみ出入りが可能です。

**警告**

此部件应安装在限制进出的场所，限制进出的场所指只能通过使用特殊工具、锁和钥匙或其它安全手段进出的场所。

**警告**

此裝置僅限安裝於進出管制區域，進出管制區域係指僅能以特殊工具、鎖頭及鑰匙或其他安全方式才能進入的區域。

### Warnung

Diese Einheit ist zur Installation in Bereichen mit beschränktem Zutritt vorgesehen. Der Zutritt zu derartigen Bereichen ist nur mit einem Spezialwerkzeug, Schloss und Schlüssel oder einer sonstigen Sicherheitsvorkehrung möglich.

### ¡Advertencia!

Esta unidad ha sido diseñada para instalación en áreas de acceso restringido. Sólo puede obtenerse acceso a una de estas áreas mediante la utilización de una herramienta especial, cerradura con llave u otro medio de seguridad.

### Attention

Cet appareil doit être installée dans des zones d'accès réservés. L'accès à une zone d'accès réservé n'est possible qu'en utilisant un outil spécial, un mécanisme de verrouillage et une clé, ou tout autre moyen de sécurité.

### אזור עם גישה מוגבלת

#### אזהרה!

יש להתקין את היחידה באזורים שיש בהם הגבלת גישה. הגישה ניתנת בעזרת כלי אבטחה בלבד (מפתח, מנעול וכד').

تم تخصيص هذه الوحدة لتكسيبها في مناطق محظورة .  
يمكن الوصول إلى منطقة محظورة فقط من خلال استخدام أداة خاصة،  
قفل ومفتاح أو أي وسيلة أخرى للأمان

경고!

이 장치는 접근이 제한된 구역에 설치하도록 되어있습니다. 특수도구, 잠금 장치 및 키, 또는 기타 보안 수단을 통해서만 접근 제한 구역에 들어갈 수 있습니다.

### Waarschuwing

Dit apparaat is bedoeld voor installatie in gebieden met een beperkte toegang. Toegang tot dergelijke gebieden kunnen alleen verkregen worden door gebruik te maken van speciaal gereedschap, slot en sleutel of andere veiligheidsmaatregelen.

## Battery Handling



### Warning!

There is the danger of explosion if the battery is replaced incorrectly. Replace the battery only with the same or equivalent type recommended by the manufacturer. Dispose of used batteries according to the manufacturer's instructions.

### 電池の取り扱い

電池交換が正しく行われなかった場合、破裂の危険性があります。交換する電池はメーカーが推奨する型、または同等のものを使用下さい。使用済電池は製造元の指示に従って処分して下さい。

### 警告

電池更換不當會有爆炸危險。請只使用同類電池或製造商推薦的功能相當的電池更換原有電池。請按製造商的說明處理廢舊電池。

### 警告

電池更換不當會有爆炸危險。請使用製造商建議之相同或功能相當的電池更換原有電池。請按照製造商的說明指示處理廢棄舊電池。

### Warnung

Bei Einsetzen einer falschen Batterie besteht Explosionsgefahr. Ersetzen Sie die Batterie nur durch den gleichen oder vom Hersteller empfohlenen Batterietyp. Entsorgen Sie die benutzten Batterien nach den Anweisungen des Herstellers.

### Attention

Danger d'explosion si la pile n'est pas remplacée correctement. Ne la remplacer que par une pile de type semblable ou équivalent, recommandée par le fabricant. Jeter les piles usagées conformément aux instructions du fabricant.

### ¡Advertencia!

Existe peligro de explosión si la batería se reemplaza de manera incorrecta. Reemplazar la batería exclusivamente con el mismo tipo o el equivalente recomendado por el fabricante. Desechar las baterías gastadas según las instrucciones del fabricante.

### אזהרה!

קיימת סכנת פיצוץ של הסוללה במידה והוחלפה בדרך לא תקינה. יש להחליף את הסוללה בסוג התואם מחברת יצרן מומלצת.

סילוק הסוללות המשומשות יש לבצע לפי הוראות היצרן.

هناك خطر من انفجار في حالة استبدال البطارية بطريقة غير صحيحة فعليك استبدال البطارية

فقط بنفس النوع أو ما يعادلها كما أوصت به الشركة المصنعة تخلص من البطاريات المستعملة وفقا لتعليمات الشركة الصانعة

경고!

배터리가 올바르게 교체되지 않으면 폭발의 위험이 있습니다. 기존 배터리와 동일하거나 제조사에서 권장하는 동등한 종류의 배터리로만 교체해야 합니다. 제조사의 안내에 따라 사용된 배터리를 처리하여 주십시오.

### Waarschuwing

Er is ontplofingsgevaar indien de batterij verkeerd vervangen wordt. Vervang de batterij slechts met hetzelfde of een equivalent type die door de fabrikant aanbevolen wordt. Gebruikte batterijen dienen overeenkomstig fabrieksvoorschriften afgevoerd te worden.

## Redundant Power Supplies



### Warning!

This unit might have more than one power supply connection. All connections must be removed to de-energize the unit.

### 冗長電源装置

このユニットは複数の電源装置が接続されている場合があります。

ユニットの電源を切るためには、すべての接続を取り外さなければなりません。

### 警告

此部件连接的电源可能不止一个，必须将所有电源断开才能停止给该部件供电。

### 警告

此裝置連接的電源可能不只一個，必須切斷所有電源才能停止對該裝置的供電。

### Warnung

Dieses Gerät kann mehr als eine Stromzufuhr haben. Um sicherzustellen, dass der Einheit kein Strom zugeführt wird, müssen alle Verbindungen entfernt werden.

### ¡Advertencia!

Puede que esta unidad tenga más de una conexión para fuentes de alimentación. Para cortar por completo el suministro de energía, deben desconectarse todas las conexiones.

### Attention

Cette unité peut avoir plus d'une connexion d'alimentation. Pour supprimer toute tension et tout courant électrique de l'unité, toutes les connexions d'alimentation doivent être débranchées.

**אם קיים יותר מספק אחד**

**אזהרה!**

ליחידה יש יותר מחיבור אחד של ספק. יש להסיר את כל החיבורים על מנת לרוקן את היחידה.

قد يكون لهذا الجهاز عدة اتصالات بوحدات امداد الطاقة.  
يجب إزالة كافة الاتصالات لعزل الوحدة عن الكهرباء

경고 !

이 장치에는 한 개 이상의 전원 공급 단자가 연결되어 있을 수 있습니다. 이 장치에 전원을 차단하기 위해서는 모든 연결 단자를 제거해야만 합니다.

### Waarschuwing

Deze eenheid kan meer dan één stroomtoevoeraansluiting bevatten. Alle aansluitingen dienen verwijderd te worden om het apparaat stroomloos te maken

### Backplane Voltage



#### Warning!

Hazardous voltage or energy is present on the backplane when the system is operating. Use caution when servicing.

バックプレーンの電圧

システムの稼働中は危険な電圧または電力が、バックプレーン上にかかっています。

修理する際にはご注意ください。

警告

当系统正在进行时，背板上有很危险的电压或能量，进行维修时务必小心。

警告

當系統正在進行時，背板上有危險的電壓或能量，進行維修時務必小心。

### Warnung

Wenn das System in Betrieb ist, treten auf der Rückwandplatine gefährliche Spannungen oder Energien auf. Vorsicht bei der Wartung.

### ¡Advertencia!

Quando el sistema está en funcionamiento, el voltaje del plano trasero es peligroso. Tenga cuidado cuando lo revise.

### Attention

Lorsque le système est en fonctionnement, des tensions électriques circulent sur le fond de panier. Prendre des précautions lors de la maintenance.

מתח בפנל האחורי

אזהרה !

קיימת סכנת מתח בפנל האחורי בזמן תפעול המערכת. יש להיזהר במהלך העבודה.

هناك خطر من التيار الكهربائي أو الطاقة الموجودة على اللوحة  
عندما يكون النظام يعمل كن حذرا عند خدمة هذا الجهاز

경고 !

시스템이 동작 중일 때 후면판 (Backplane) 에는 위험한 전압이나 에너지가 발생 합니다. 서비스 작업 시 주의하십시오 .

### Waarschuwing

Een gevaarlijke spanning of energie is aanwezig op de backplane wanneer het systeem in gebruik is. Voorzichtigheid is geboden tijdens het onderhoud.

## Comply with Local and National Electrical Codes



### Warning!

Installation of the equipment must comply with local and national electrical codes.

地方および国の電気規格に準拠

機器の取り付けはその地方および国の電気規格に準拠する必要があります。

警告

设备安装必须符合本地与本国电气法规。

警告

設備安裝必須符合本地與本國電氣法規。

### Warnung

Die Installation der Geräte muss den Sicherheitsstandards entsprechen.

### ¡Advertencia!

La instalacion del equipo debe cumplir con las normas de electricidad locales y nacionales.

### Attention

L'équipement doit être installé conformément aux normes électriques nationales et locales.

## תיאום חוקי החשמל הארצי

אזהרה !

התקנת הציוד חייבת להיות תואמת לחוקי החשמל המקומיים והארציים.

تركيب المعدات الكهربائية يجب أن يمتثل للقوانين المحلية والوطنية المتعلقة  
بالكهرباء

경고!

현 지역 및 국가의 전기 규정에 따라 장비를 설치해야 합니다.

### Waarschuwing

Bij installatie van de apparatuur moet worden voldaan aan de lokale en nationale elektriciteitsvoorschriften.

## Product Disposal



### Warning!

Ultimate disposal of this product should be handled according to all national laws and regulations.

### 製品の廃棄

この製品を廃棄処分する場合、国の関係する全ての法律・条例に従い処理する必要があります。

### 警告

本产品的废弃处理应根据所有国家的法律和规章进行。

### 警告

本產品的廢棄處理應根據所有國家的法律和規章進行。

### Warnung

Die Entsorgung dieses Produkts sollte gemäß allen Bestimmungen und Gesetzen des Landes erfolgen.

### ¡Advertencia!

Al deshacerse por completo de este producto debe seguir todas las leyes y reglamentos nacionales.

### Attention

La mise au rebut ou le recyclage de ce produit sont généralement soumis à des lois et/ou directives de respect de l'environnement. Renseignez-vous auprès de l'organisme compétent.

## סילוק המוצר

אזהרה!

סילוק סופי של מוצר זה חייב להיות בהתאם להנחיות וחוקי המדינה.

عند التخلص النهائي من هذا المنتج ينبغي التعامل معه وفقا لجميع القوانين واللوائح الوطنية

경고!

이 제품은 해당 국가의 관련 법규 및 규정에 따라 폐기되어야 합니다.

### Waarschuwing

De uiteindelijke verwijdering van dit product dient te geschieden in overeenstemming met alle nationale wetten en reglementen.

### Hot Swap Fan Warning



#### Warning!

The fans might still be turning when you remove the fan assembly from the chassis. Keep fingers, screwdrivers, and other objects away from the openings in the fan assembly's housing.

#### ファン・ホットスワップの警告

シャーシから冷却ファン装置を取り外した際、ファンがまだ回転している可能性があります。ファンの開口部に、指、ドライバー、およびその他のものを近づけないで下さい。

#### 警告

当您从机架移除风扇装置，风扇可能仍在转动。小心不要将手指、螺丝起子和其他物品太靠近风扇。

#### 警告

當您從機架移除風扇裝置，風扇可能仍在轉動。小心不要將手指、螺絲起子和其他物品太靠近風扇。

### Warnung

Die Lüfter drehen sich u. U. noch, wenn die Lüfterbaugruppe aus dem Chassis genommen wird. Halten Sie Finger, Schraubendreher und andere Gegenstände von den Öffnungen des Lüftergehäuses entfernt.

### ¡Advertencia!

Los ventiladores podran dar vuelta cuando usted quite ell montaje del ventilador del chasis. Mandtenga los dedos, los destornilladores y todos los objetos lejos de las aberturas del ventilador

### Attention

Il est possible que les ventilateurs soient toujours en rotation lorsque vous retirerez le bloc ventilateur du châssis. Prenez garde à ce que doigts, tournevis et autres objets soient éloignés du logement du bloc ventilateur.

! אזהרה

כאשר מסירים את חלקי המאוורר מהמארו, יתכן והמאווררים עדיין עובדים. יש להרחיק למרחק בטוח את האצבעות וכלי עבודה שונים מהפתחים בתוך המאוורר

من الممكن أن المراوح لا تزال تدور عند إزالة كتلة المروحة من الهيكل يجب إبقاء الأصابع ومفكات البراغي وغيرها من الأشياء بعيدا عن الفتحات في كتلة المروحة.

경고 !

새시로부터 팬 조립품을 제거할 때 팬은 여전히 회전하고 있을 수 있습니다. 팬 조립품 외관의 열려있는 부분들로부터 손가락 및 스크류드라이버, 다른 물체들이 가까이 하지 않도록 배치해 주십시오.

### Waarschuwing

Het is mogelijk dat de ventilator nog draait tijdens het verwijderen van het ventilatorsamenstel uit het chassis. Houd uw vingers, schroevendraaiers en eventuele andere voorwerpen uit de buurt van de openingen in de ventilatorbehuizing.

## Power Cable and AC Adapter



### Warning!

When installing the product, use the provided or designated connection cables, power cables and AC adaptors. Using any other cables and adaptors could cause a malfunction or a fire. Electrical Appliance and Material Safety Law prohibits the use of UL or CSA -certified cables (that have UL/CSA shown on the code) for any other electrical devices than products designated by Supermicro only.

### 電源コードと AC アダプター

製品を設置する場合、提供または指定された接続ケーブル、電源コードと AC アダプターを使用下さい。他のケーブルやアダプタを使用すると故障や火災の原因になることがあります。電気用品安全法は、UL または CSA 認定のケーブル (UL/CSE マークがコードに表記) を Supermicro が指定する製品以外に使用することを禁止しています。

### 警告

安装此产品时,请使用本身提供的或指定的连接线,电源线和电源适配器.使用其它线材或适配器可能会引起故障或火灾。除了 Supermicro 所指定的产品,电气用品和材料安全法律规定禁止使用未经 UL 或 CSA 认证的线材。(线材上会显示 UL/CSA 符号)。

### 警告

安裝此產品時,請使用本身提供的或指定的連接線,電源線和電源適配器.使用其它線材或適配器可能會引起故障或火災。除了 Supermicro 所指定的產品,電氣用品和材料安全法律規定禁止使用未經 UL 或 CSA 認證的線材。(線材上會顯示 UL/CSA 符號)。

## Warnung

Bei der Installation des Produkts, die zur Verfügung gestellten oder benannt Anschlusskabel, Stromkabel und Netzteile. Verwendung anderer Kabel und Adapter kann zu einer Fehlfunktion oder ein Brand entstehen. Elektrische Geräte und Material Safety Law verbietet die Verwendung von UL-oder CSA-zertifizierte Kabel, UL oder CSA auf der Code für alle anderen elektrischen Geräte als Produkte von Supermicro nur bezeichnet gezeigt haben.

## ¡Advertencia!

Al instalar el producto, utilice los cables de conexión previstos o designados, los cables y adaptadores de CA. La utilización de otros cables y adaptadores podría ocasionar un mal funcionamiento o un incendio. Aparatos Eléctricos y la Ley de Seguridad del Material prohíbe el uso de UL o CSA cables certificados que tienen UL o CSA se muestra en el código de otros dispositivos eléctricos que los productos designados por Supermicro solamente.

## Attention

Lors de l'installation du produit, utilisez les bables de connection fournis ou désigné. L'utilisation d'autres cables et adaptateurs peut provoquer un dysfonctionnement ou un incendie. Appareils électroménagers et de loi sur la sécurité Matériel interdit l'utilisation de UL ou CSA câbles certifiés qui ont UL ou CSA indiqué sur le code pour tous les autres appareils électriques que les produits désignés par Supermicro seulement.

## חשמליים ומתאמי AC

אזהרה!

כאשר מתקינים את המוצר, יש להשתמש בכבלים, ספקים ומתאמים AC אשר נועדו וסופקו לשם כך. שימוש בכל כבל או מתאם אחר יכול לגרום לתקלה או קצר חשמלי. על פי חוקי שימוש במכשירי חשמל וחוקי בטיחות, קיים איסור להשתמש בכבלים המוסמכים ב- UL או ב- CSA (כשאר מופיע עליהם קוד של UL/CSA) עבור כל מוצר חשמלי אחר שלא צוין על ידי סופרקמיקרו בלבד.

عند تركيب الجهاز يجب استخدام كابلات التوصيل، والكابلات الكهربائية ومحولات التيار المتردد التي . أن استخدام أي كابلات ومحولات أخرى يتسبب في حدوث عطل أو حريق. تم توفيرها لك مع المنتج الأجهزة الكهربائية ومواد قانون السلامة يحظر استخدام الكابلات UL أو CSA معتمدة من قبل لأي أجهزة كهربائية أخرى غير المنتجات المعينة من قبل Supermicro (التي تحمل علامة UL/CSA)

**경고 !**

제품을 설치할 때에는 제공되거나 지정된 연결케이블과 전원케이블, AC 어댑터를 사용해야 합니다. 그 밖의 다른 케이블들이나 어댑터들은 고장 또는 화재의 원인이 될 수 있습니다. 전기용품안전법 (Electrical Appliance and Material Safety Law) 은 슈퍼마이크로에서 지정한 제품들 외에는 그 밖의 다른 전기 장치들을 위한 UL 또는 CSA 에서 인증한 케이블 (전선 위에 UL/CSA 가 표시) 들의 사용을 금지합니다.

**Waarschuwing**

Bij het installeren van het product, gebruik de meegeleverde of aangewezen kabels, stroomkabels en adapters. Het gebruik van andere kabels en adapters kan leiden tot een storing of een brand. Elektrisch apparaat en veiligheidsinformatiebladen wet verbiedt het gebruik van UL of CSA gecertificeerde kabels die UL of CSA die op de code voor andere elektrische apparaten dan de producten die door Supermicro alleen.

## Notes

---

---

# Chapter 3

## Setup and Installation

### 3-1 Overview

This chapter covers the setup and installation of the blade module and its components.

### 3-2 Installing Blade Modules

Up to fourteen SBI-7428R-T3/T3N blade module may be installed into a single blade enclosure. Blade modules with Windows and Linux operating systems may be mixed together in the same blade enclosure.

#### Powering Up a Blade Unit

Each blade unit may be powered on and off independently from the rest of the blades installed in the same enclosure. A blade unit may be powered up in two ways:

- Press the power button on the blade unit.
- Use IPMIView or the web-browser based management utility to apply power using the CMM module.

#### Powering Down a Blade Unit

A blade unit may be powered down in either of the following ways:

- Press the power button on the blade unit.
- Use IPMIView or the web-browser based management utility to power down (if you have Operator or Admin privileges on the CMM).
- Use IPMITool when connected to the CMM to power down (if you have Operator or Admin privileges on the CMM).

## Removing a Blade Unit from the Enclosure

Although the blade system may continue to run, individual blades should always be powered down before removing them from the enclosure.

### *Removing a Blade Unit from the Enclosure*

1. Power down the blade unit (see ["Powering Down a Blade Unit"](#) above).
2. Squeeze both handles to depress the red sections then pull out both handles completely and use them to pull the blade unit from the enclosure.

**NOTE:** Blade Modules can be Hot-Plugged from the enclosure.

## Removing/Replacing the Blade Cover

The blade cover must be removed to access the mainboard when you need to install or remove processors, memory units, the onboard battery and so on.

### *Removing/Replacing the Blade Cover*

1. Remove the blade unit from the enclosure (see ["Removing a Blade Unit from the Enclosure"](#) above).
2. Depress the two buttons on the cover while pushing the cover toward the rear of the blade unit. When it stops, lift the cover off the blade unit.
3. To replace the cover, fit the six grooves in the cover into the studs in the sides of the blade, then slide the cover toward the front of the blade to lock it into place.

## Installing a Blade Unit into the Enclosure

Make sure the cover of the blade unit has been replaced first before installing a blade unit in the enclosure.

### *Installing a Blade Unit into the Enclosure*

1. Slowly push the blade unit into its bay with the handles fully pulled out (see [Figure 3-1](#)).
2. When the blade stops, push the handles back in to their locked position, making sure the notches in both handles catch the lip of the enclosure (see [Figure 3-2](#)).

**NOTE:** Blade Modules can be Hot-Plugged into the enclosure.

**WARNING:** Use extreme caution when inserting a blade module into the enclosure. If the blade's power connector becomes damaged, it can damage pins on other blade bays that it is inserted into.

Figure 3-1. Inserting a Blade into the Enclosure

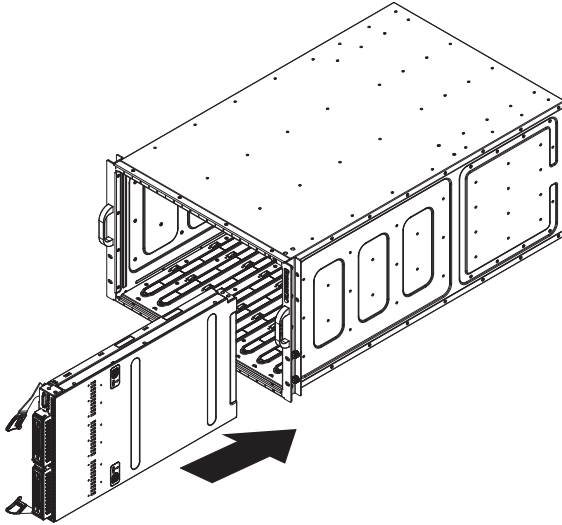
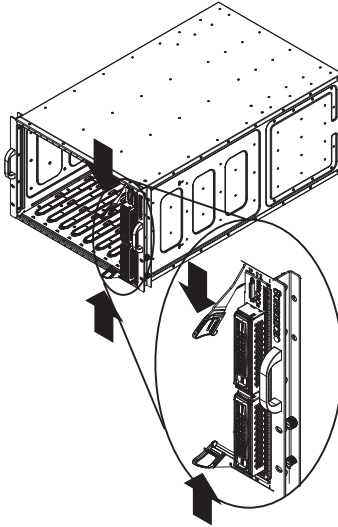


Figure 3-2. Locking the Blade into Position



### 3-3 Processor Installation

One or two processors may be installed to the mainboard of each blade unit. See [Chapter 1](#) for general information on the features of the blade unit and the [Supermicro web site](#) for further details including processor, memory and operating system support.

**WARNING:** This action should only be performed by a trained service technician. Allow the processor heatsink to cool before removing it.

#### ***Removing a Processor***

1. Power down and remove the blade unit from the enclosure (see [Section 3-2: Installing Blade Modules on page 3-1](#) for details).
2. Remove the cover of the blade unit (see "[Removing/Replacing the Blade Cover](#)" on [page 3-2](#)).
3. Loosen the four screws that secure the heatsink to the mainboard.
4. Remove the heatsink by *gently* rotating it back-and-forth sideways with your fingers to release it from the processor. Set the heatsink aside and upside-down so that nothing comes into contact with the thermal grease on its underside.
5. Raise the lever of the processor socket up until the processor is released from the socket, then lift the silver cover plate and remove the processor.
6. Reapply plastic socket covers to the LGA2011 sockets to prevent pin damage.

**WARNING:** This action should only be performed by a trained service technician.

### Installing a Processor

**WARNING:** When handling the processor package, avoid placing direct pressure on the label area.

**WARNING:** Always connect the power cord last, and always remove it before adding, removing or changing any hardware components. Make sure that you install the processor into the CPU socket before you install the CPU heatsink.

**Important!** If you buy a CPU separately, make sure that you use an Intel-certified multi-directional heatsink only.

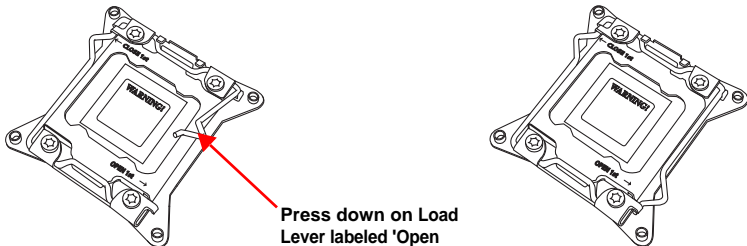
**WARNING:** Make sure to install the system board into the chassis before you install the CPU heatsink.

**WARNING:** When receiving a server board without a processor pre-installed, make sure that the plastic CPU socket cap is in place and none of the socket pins are bent; otherwise, contact your retailer immediately.

**WARNING:** Refer to the Supermicro website for updates on CPU support.

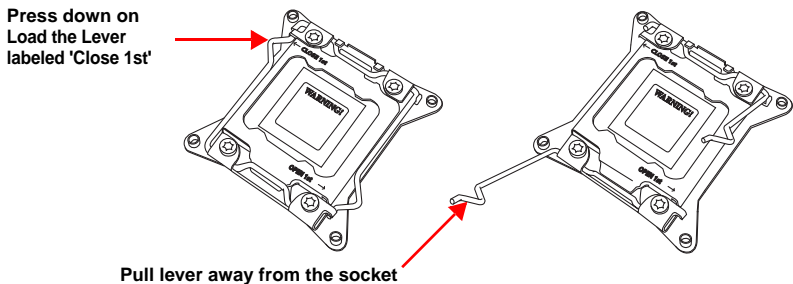
1. There are two load levers on the LGA2011 socket. To open the socket cover, first press and release the load lever labeled 'Open 1st' (Figure 3-3).

Figure 3-3. Open First Load Lever



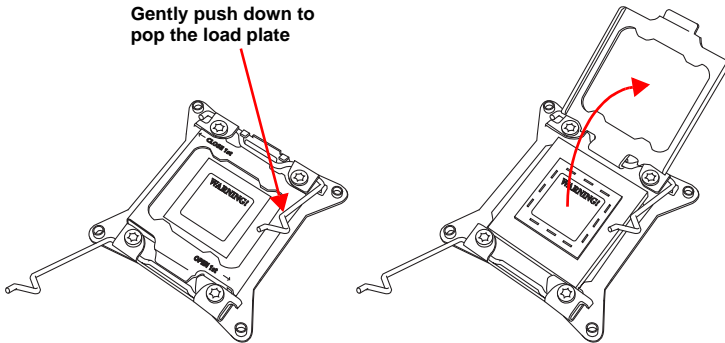
2. Press the second load lever labeled 'Close 1st' to release the load plate that covers the CPU socket from its locking position (Figure 3-4).

Figure 3-4. Close First Load Lever



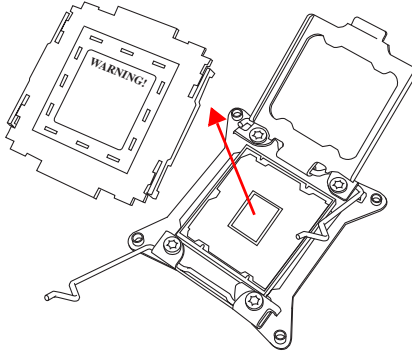
3. With the lever labeled 'Close 1st' fully retracted, gently push down on the 'Open 1st' lever to open the load plate. Lift the load plate to open it completely (Figure 3-5).

**Figure 3-5. Opening the Load Plate**



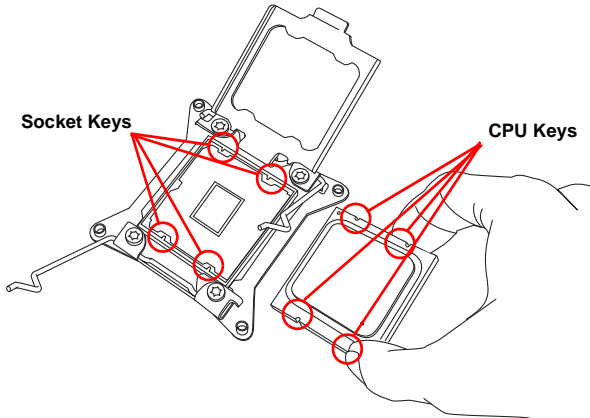
4. Using your thumb and the index finger, remove the 'WARNING' plastic cap from the socket (Figure 3-6).

**Figure 3-6. Removing the Warning Plastic Cap**



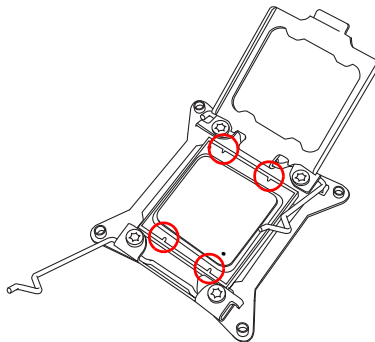
5. Use your thumb and index finger to hold the CPU on its edges. Align the CPU keys, which are semi-circle cutouts, against the socket keys (Figure 3-7).

**Figure 3-7. Aligning CPU Keys with Socket Keys**



6. Once the keys are aligned, carefully lower the CPU straight down into the socket (Figure 3-8). Do not drop the CPU on the socket. Do not move the CPU horizontally or vertically. Do not rub the CPU against the surface or against any pins of the socket to avoid damaging the CPU or the socket.

**Figure 3-8. Lowering the CPU into the Socket**

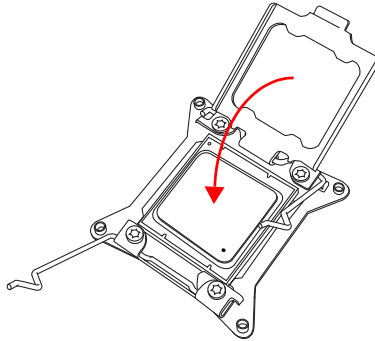


**WARNING:** You can only install the CPU inside the socket in one direction. Make sure that the CPU is properly inserted into the CPU socket before closing the load plate. If it doesn't close properly, do not force it as it may damage your CPU. Instead, open the load plate again and double-check that the CPU is aligned properly.

7. With the CPU inside the socket, inspect the four corners of the CPU to make sure that the CPU is properly installed.

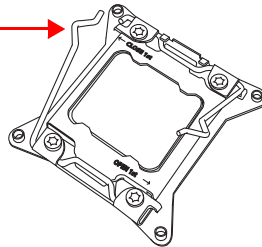
8. Close the load plate with the CPU inside the socket (Figure 3-9). Lock the lever labeled 'Close 1st' first (Figure 3-10), then lock the lever labeled 'Open 1st' second (Figure 3-11). Use your thumb to gently push the load levers down to the lever locks.

**Figure 3-9. Closing the Load Plate**

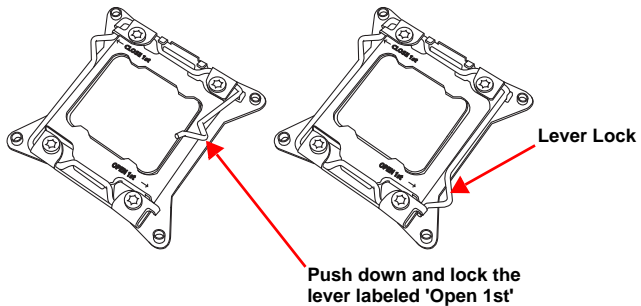


**Figure 3-10. Locking the Close First Lever**

Push down and lock the level labeled 'Close 1st'.



**Figure 3-11. Locking the Open 1st Lever**

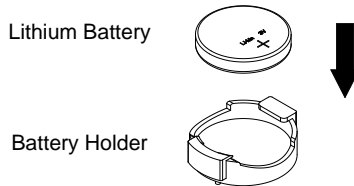


### 3-4 Onboard Battery Installation

A battery is included on the mainboard to supply certain volatile memory components with power when power has been removed from the blade module. If this battery dies, it must be replaced with an equivalent CR2032 Lithium 3V battery. Dispose of used batteries according to the manufacturer's instructions. See [Figure 3-12](#) for a diagram of installing a new onboard battery.

**WARNING:** There is a danger of explosion if the onboard battery is installed upside down, which reverses its polarities.

**Figure 3-12. Installing the Onboard Battery**



### 3-5 Memory Installation

The mainboard of each blade unit must be populated with DIMMs (Dual In-line Memory Modules) to provide system memory. **The DIMMs should all be of the same size and speed and from the same Super Micro authorized manufacturer due to compatibility issues.** See details below on supported memory and our web site ([www.supermicro.com/products/superblade](http://www.supermicro.com/products/superblade) for recommended memory.

**WARNING:** For all SBI-7428 series blades, *ONLY* VLP (Very low profile) memory can be used.

#### Populating Memory Slots

The mainboard of a SBI-7428R-T3/T3N blade module has sixteen (16) 288-pin DDR4 DIMM memory slots, eight for each processor. Both interleaved and non-interleaved memory are supported, so you may populate any number of DIMM slots.

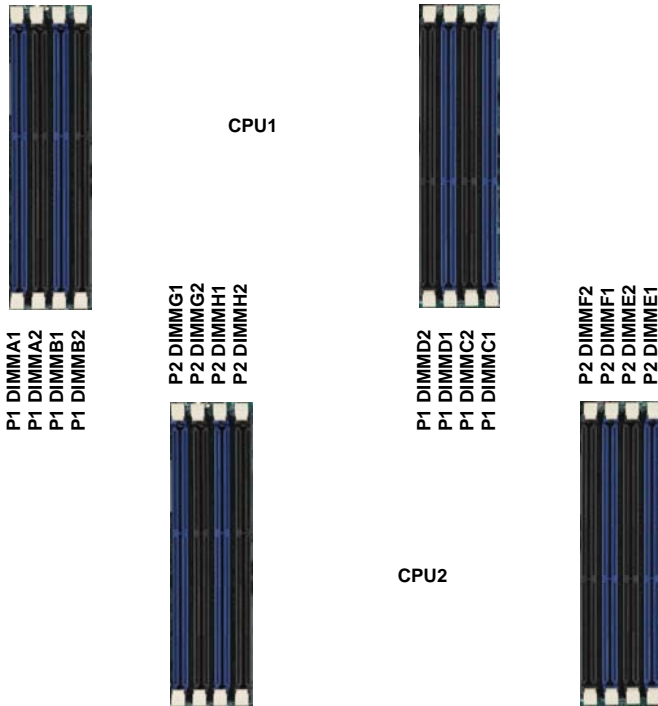
Populating two slots at a time (DIMM1A + DIMM2A, DIMM3A + DIMM4A, etc.) with memory modules of the same size and of the same type will result in dual-channel, interleaved memory, which is faster than single-channel, non-interleaved memory. See [Table 3-1: "Populating Eight Memory Slots for Interleaved Operation" on page 3-10](#) for details.

**WARNING:** For an interleaved configuration, memory modules of the same size and speed must be installed in pairs. You should not mix DIMMs of different sizes and speeds.

Table 3-1. Populating Eight Memory Slots for Interleaved Operation

# of DIMMs	CPU1								CPU2							
	Channel A		Channel B		Channel C		Channel D		Channel E		Channel F		Channel G		Channel H	
	A1	A2	B1	B2	C1	C2	D1	D2	E1	E2	F1	F2	G1	G2	H1	H2
4	X		X						X		X					
8	X		X		X		X		X		X		X		X	
12	X	X	X	X	X		X		X	X	X	X	X		X	
16	X	X	X	X	X	X	X	X	X	X	X	X	X	X	X	X

Figure 3-13. 16-slot DIMM Numbering



**NOTE:** Though multiple DIMM memory module types and speeds may be supported, you need to use DIMM memory modules of the same speed and type.

**NOTE:** An “X” in Table 3-1 indicates the memory slot is populated by a DIMM module.

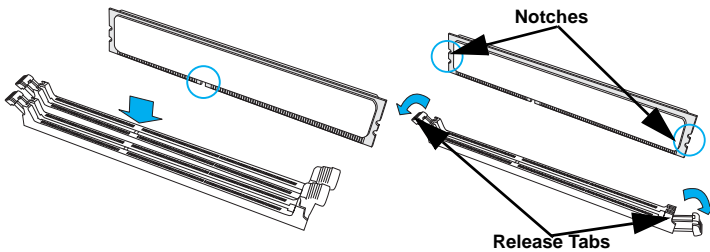
**NOTE:** For an optimized memory bandwidth, it is recommended that you populate the memory modules in sets of four (4) DIMMs for the CPU’s.

## DIMM Installation

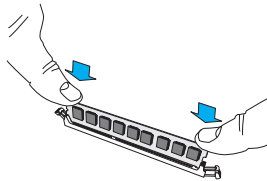
**Warning:** Exercise extreme care when installing or removing DIMM modules to prevent any possible damage.

### Installing & Removing DIMMs

1. Insert the desired number of DIMMs into the memory slots, starting with P1-DIMMA1. (For best performance, please use the memory modules of the same type and speed in the same bank.)
2. Push the release tabs outwards on both ends of the DIMM slot to unlock it.



3. Align the key of the DIMM module with the receptive point on the memory slot.
4. Align the notches on both ends of the module against the receptive points on the ends of the slot.
5. Use two thumbs together to press the notches on both ends of the module straight down into the slot until the module snaps into place.
6. Press the release tabs to the locking positions to secure the DIMM module into the slot.



**Note:** Check Supermicro's website for recommended memory modules.

### Removing Memory Modules

Press the release tabs on both ends of the memory module to unlock it. Once it is loosened, remove the DIMM module from the memory slot.

## 3-6 Hard Disk Drive Installation

Hard disk drives are installed in “carriers” which are hot-swappable and can be removed or replaced without powering down the blade unit they reside in. A blade module needs a hard disk drive with an operating system installed to operate.

**WARNING:** To maintain proper airflow, both hard drive bays must have drive carriers inserted during operation whether or not a drive is installed in the carrier.

To remove a hard drive carrier, do the following:

### ***Removing a Hard Drive Carrier***

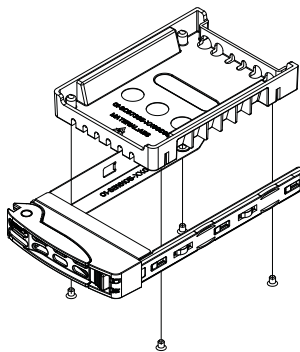
1. Locate the colored “Open” button at the bottom of the drive carrier and press it with your thumb. This action releases the drive carrier from the drive bay.
2. Pull the release handle out about 45-degrees, then use it to pull the drive carrier out.

To Install a hard drive, use the following procedure:

### ***Installing a Hard Drive***

1. Remove a blank drive carrier from the blade (see removal procedure above).
2. Insert a drive into the carrier with the PCB side facing down and the connector end toward the rear of the carrier.
3. Align the drive in the carrier so that the screw holes of both line up. Note that there are holes in the carrier marked “SATA” to aid in correct installation.
4. Secure the drive to the carrier with six screws as shown in [Figure 3-14](#).
5. Insert the drive carrier into its slot keeping the Open button at the bottom. When the carrier reaches the rear of the bay the release handle will retract.
6. Push the handle in until you hear the carrier click into its locked position.

**Figure 3-14. Installing a Hard Drive in a Carrier**



## 3-7 Installing the Operating System

An operating system (OS) must be installed on each blade module. Blades with Microsoft Windows OS and blades with Linux OS can both occupy and operate within the same blade enclosure. Refer to the SuperMicro web site for a complete list of supported operating systems.

There are several methods of installing an OS to the blade modules.

### Installing with an External USB CD-ROM Drive

The most common method of installing the OS is with an external USB CD-ROM drive. Take the following steps to install the OS to a blade module:

**WARNING:** Installing the OS from an external CD-ROM drive may take several hours to complete.

1. Connect an SUV cable (Serial port/USB port/Video port cable) to the KVM connector on the front of the blade module. You will then need to attach a USB hub to the USB port on this cable to provide multiple USB ports.
2. Connect the external CD-ROM drive, a USB keyboard and a mouse to the USB hub. You will also need to connect a monitor to the video connector on the SUV cable. Turn on the blade module.
3. Insert the CD containing the OS into the CD-ROM drive.
4. Follow the prompts to begin the installation.

### Installing via PXE Boot

PXE (Preboot Execution Environment) is used to boot a computer over a network. To install the OS via PXE, the following conditions must be met:

1. The PXE BOOT option in BIOS must be enabled.
2. A PXE server has been configured (this can be another blade in the system).
3. The PXE server must be connected over a network to the blade to be booted.
4. The blade has only non-partitioned/unformatted hard drives installed and no bootable devices attached to it.

Once these conditions are met, make sure the PXE server is running. Then turn on the blade on which you wish to boot and/or install the OS. The BIOS in the blade will look at all bootable devices and finding none will connect to the PXE server to begin the boot/install.

## Installing via Virtual Media (Drive Redirection)

You can install the OS via Virtual Media through either the *IPMIview* (Java based client utility), *IPMITool* or the *Web-based Management Utility*. With this method, the OS is installed from an ISO image that resides on another system/blade.

Refer to the manuals on your SuperBlade CD-ROM for further details on the Virtual Media (CD-ROM or Drive Redirection) sections of these two utility programs.

## 3-8 Management Software

System management may be performed with either of three software packages: *IPMIview*, *IPMITool* or a *Web-based Management Utility*. These are designed to provide an administrator with a comprehensive set of functions and monitored data to keep tabs on the system and perform management activities.

Refer to the manuals on your SuperBlade CD-ROM for further details on the various functions provided by these management programs.

## 3-9 Configuring and Setting up RAID

Each blade module that supports two or more hard drives may be used to create a RAID array. The procedures for doing this vary depending upon the blade model chosen for your SuperBlade system.

See [Chapter 5](#) for details on how to configure and set up RAID on your blade module.

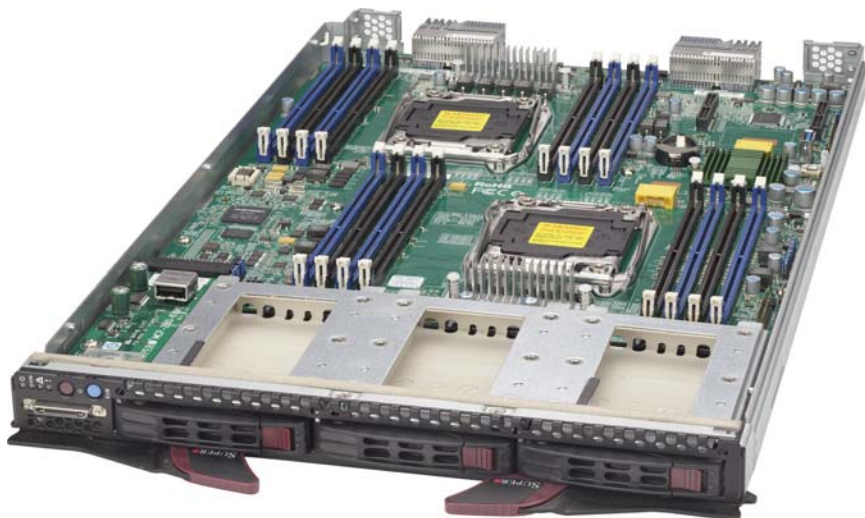
---

---

# Chapter 4

## Blade Module Features

Figure 4-1. SBI-7428R-T3/T3N Blade Unit Front View



This chapter describes the SBI-7428R-T3/T3N blade unit. Installation and maintenance should be performed by experienced technicians only.

See [Figure 4-1](#) for a front view of the blade unit and [Table 4-1](#) for its features.

Table 4-1. SBI-7428R-T3/T3N Blade Unit Features

Feature	Description
Processors	Supports single or dual 2011-pin (LGA2011 Socket R) Intel Xeon E5-2600 V3/V4 series processors
Memory	Supports up to 512 GB of VLP RDIMM in 32 GB, 16 GB, 8 GB or 4 GB VLP RDIMM size, and 2400/2133/1866/1600 MHz speed SDRAM in sixteen (16) 288-pin DDR4 DIMM sockets with 1.2 V voltage
Storage	Up to three hot-plug 2.5" Hot-swap HDD/SSD/NVMe hot pluggable 2.5" enterprise drives
Ports	KVM (1), SATA (1) connectors
Features	Onboard Aspeed AST2400 BMC Graphics chip, IPMI 2.0, ATA/100, Plug and Play, APM 1.2, DMI 2.3, PCI 2.2, ACPI up to 3.0, SMBIOS 2.3, Real Time Clock, Watch Dog, VMDq support, Intel® I/OAT 3 support

## 4-1 Control Panel

Each blade has a similar control panel (Figure 4-2) with power on/off button, a KVM connector, a KVM button and four LEDs on the top front of the unit. The numbers mentioned in Figure 4-2 are described in Table 4-2.

Figure 4-2. Blade Control Panel

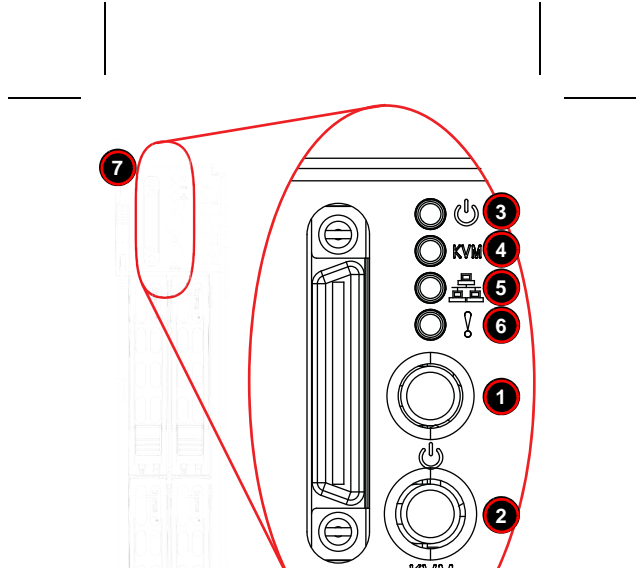


Table 4-2. Blade Control Panel

Item	Function	State	Description
1	Power Button	N/A	Turns blade module on and off
2	KVM Button	N/A	Initiates KVM function
3	Power LED	Green	Indicates power status "On"
		Orange	Indicates power status "Off" (with power cables plugged in)
4	KVM/UID LED	Blue	Indicates KVM being utilized on blade unit
		Flashing Blue	Indicates UID activated on blade module
5	Network/IB LED	Flashing Green	Indicates network activity over LAN
		Flashing Orange	Indicates network activity over InfiniBand module
6	System Fault LED	Red	Indicates a memory error, overheat, VGA error or any error that prevents booting
7	KVM Connector	N/A	Connector for SUV/KVM cable

## Power Button

Each blade has its own power button so that individual blade units within the enclosure may be turned on or off independently of the others. Press the power button (#1) to turn on the blade server. The power LED (#3) will turn green. To turn off, press and hold the power button for >4 seconds and the power LED will turn orange.

## KVM Button

KVM stands for Keyboard/Video/Mouse. With KVM, a user can control multiple blades with a single keyboard/video/mouse setup. Connect your keyboard, mouse and monitor to the USB and VGA connectors on the CMM module, then push the KVM button on the control panel of the blade module you wish to access.

## LED Indicators

Blade module LEDs are described below in [Table 4-3](#).

**Table 4-3. Blade Module LED Indicators**

LED	State	Description
Power LED	Green	Power On
	Amber	Standby
	Red	Power Failure <sup>a</sup>
KVM/UID LED (Blue)	Steady On	Indicates that KVM has been initialized on this blade module
	Flashing	Serves as a UID indicator (the UID function is activated with a management program)
Network LED (Green)	Flashing	Flashes on and off to indicate traffic (Tx and Rx data) on the LAN connection to this blade module.
System Fault LED (Red)	Steady On	This LED illuminates red when a fatal error occurs. This may be the result of a memory error, a VGA error or any other fatal error that prevents the operating system from booting up.

- a. In the event of a power failure, the N+1 Redundant Power Supply (if included in your system's configuration) automatically turns on and picks up the system load to provide uninterrupted operation. The failed power supply should be replaced with a new one as soon as possible.

## KVM Connector

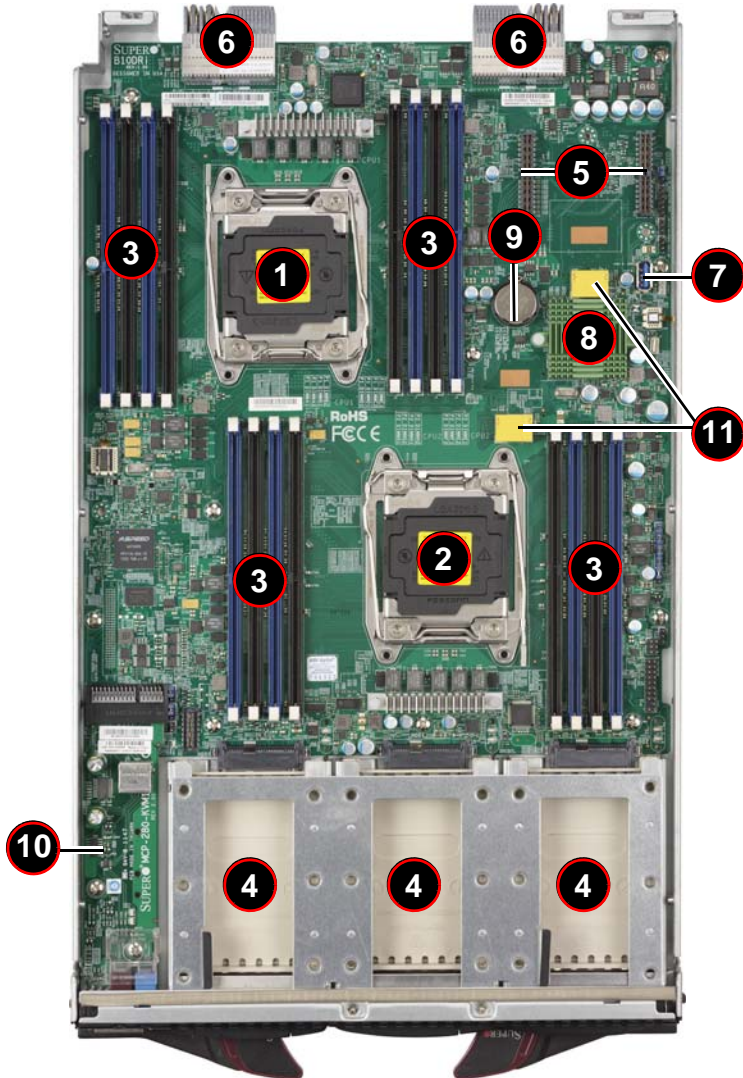
Alternatively, you may connect a KVM cable (CBL-0218L, with a keyboard/video/mouse attached) to the KVM connector (#7) of the blade you wish to access. To switch to another blade, disconnect the cable then reconnect it to the new blade.

See the *Web-based Management Utility User's Manual* on your SuperBlade system CD-ROM for further details on using the KVM function remotely.

## 4-2 Mainboard

The mainboard of the SBI-7428R-T3/T3N blade unit is a proprietary design, which is based on the Intel C612 chipset. See [Figure 4-4](#) for a block diagram of this chipset, [Figure 4-3](#) for a view of the B10DRI mainboard and [Figure 4-5](#) for an exploded view diagram of the blade unit.

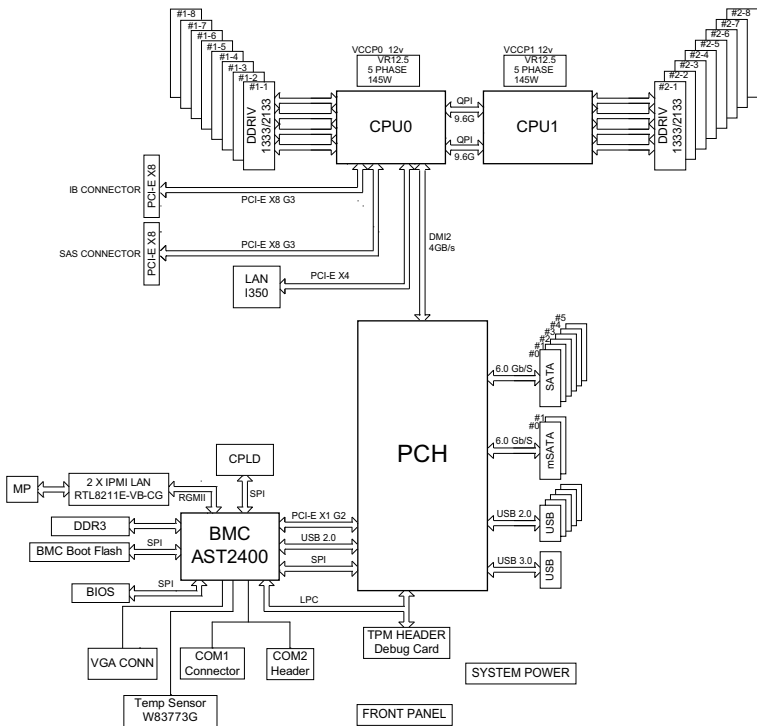
Figure 4-3. B10DRI Mainboard



**Table 4-4. B10DRI Mainboard Layout**

Item	Description
1	LGA 2011 CPU1 Socket
2	LGA 2011 CPU2 Socket
3	DIMM Slots (see <a href="#">Figure 3-13: "16-slot DIMM Numbering" on page 3-10</a> for details) (sixteen)
4	2.5" Hot-swap HDD/SSD/NVMe SATA Hard Drive Bays (three)
5	InfiniBand Connectors (for InfiniBand daughter card) (two)
6	Gbx Connectors (for power and logic to backplane) (two)
7	Onboard SATA Port
8	Intel C612 Chipset
9	Onboard Battery
10	KVM Module
11	SuperDOM (Disk on Module) ports (two)

**Figure 4-4. Intel C612 Chipset: Block Diagram**



## Jumpers

The jumpers present on the mainboard are used by the manufacturer only; there are no jumpers used to configure the operation of the mainboard.

## CMOS Clear

JBT1 is used to clear CMOS and will also clear any passwords. JBT1 consists of two contact pads located near the BIOS chip.

### *Clearing CMOS*

1. First power down the blade and remove it from the enclosure.
2. Remove the blade cover to access the mainboard (see [Section : Removing/ Replacing the Blade Cover on page 3-2](#) for further details). Short the CMOS pads with a metal object such as a small screwdriver.
3. Replace the cover, install the blade back into the enclosure and power it on.

### 4-3 Blade Unit Components

Figure 4-5. Exploded View of a SBI-7428R-T3/T3N Blade Module

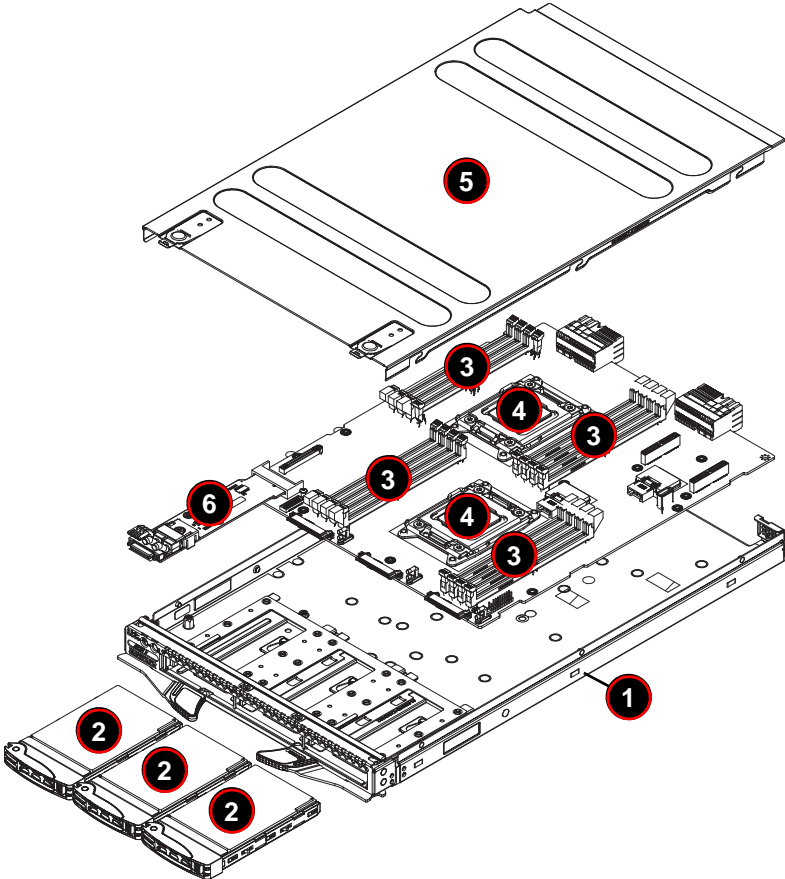


Table 4-5. Main Components of a SBI-7428R-T3/T3N Blade Module

Item	Description
1	Blade Unit/Module
2	2.5" Hot-swap HDD/SSD/NVMe Hard Drives
3	DIMMs (system memory)
4	CPUs (2)
5	Top Cover
6	KVM Module

## Memory Support

The SBI-7428R-T3/T3N blade module supports up to 256 GB of 32 GB, 16 GB, 8 GB or 4 GB VLP RDIMM size, 2400/2133/1866/1600 MHz speed SDRAM memory in sixteen (16) 288-pin DDR4 DIMM sockets. See [Section 3-5: Memory Installation on page 3-9](#) for further details on mainboard memory installation.

## Hard Disk Drives

The SBI-7428R-T3/T3N blade unit accommodates up to three 2.5" Hot-swap HDD/SSD/NVMe SATA hard disk drives, which are mounted in drive "trays". The drives can be hot-swapped and removed or replaced without powering down the blade unit they reside in. The three drives can be used to set up a RAID 0 and 1 array. These drives use a yellow color for the Blade HDD active LED. See [Chapter 5: "RAID Setup Procedure" on page 5-1](#) for further details on RAID Setup. See ["NVMe" on page 1-3](#) for details on NVMe drives.

The SBI-7428R-T3/T3N blade module also has two SuperDOM ports for attaching SuperDOM drives to the serverboard. See <http://www.supermicro.com/products/nfo/satadom.cfm> for details on SuperDOM ports.

**WARNING:** To maintain proper airflow, both hard drive bays must have drive carriers inserted during operation whether or not a drive is installed in the tray.

---

---

# Chapter 5

## RAID Setup Procedure

Each SBI-7428R-T3/T3N blade module supports up to three hard drives, which may be used to create a RAID 0 and 1 (Windows) or RAID 0, 1 and 10 (Linux) array. For RAID setup use the procedure below. This blade's BIOS has a RAID utility available in its setup.

### 5-1 RAID Configurations

With two or hard drives per blade, the following RAID configurations are supported:

- RAID 0 (Data Striping): this writes data in parallel, interleaved ("striped") sections on two hard drives. Data transfer rate is doubled over using a single disk.
- RAID1 (Data Mirroring): an identical data image from one drive is copied to another drive. The second drive must be the same size or larger than the first drive.
- Enhanced RAID 5 or RAID 10 (Data Mirroring): as RAID1 with data mirrored from one or more disks to one or more disks of a second, larger size. You can couple the disks from the source to create a virtual volume and use one or more disks of a second, larger size to provide a single larger volume (or multiple larger volumes) that serve as the mirroring drive or drives for the array.

### 5-2 Preparing for Setup

Before you begin the installation, verify the following:

1. The SBI-7428R-T3/T3N blade module has two or more hard drives installed.
2. These drives must not have an OS installed and must be non-partitioned (formatted is ok).
3. The installation procedure is done via KVM, so have a KVM cable (CBL-0218L) connected to the KVM connector on the blade module with a keyboard, mouse and monitor attached.

**NOTE:** You may also instead use IPMI or the Web-based Management utility to access the blade.

## 5-3 RAID Setup Procedure

This section provides instructions for configuring arrays and logical drives with the RAID BIOS Configuration Utility.

It is recommended that you use drives with the same capacity when you create a storage configuration. If you use drives with different capacities in one array, the configuration utility limits each drive to the capacity of the smallest drive.

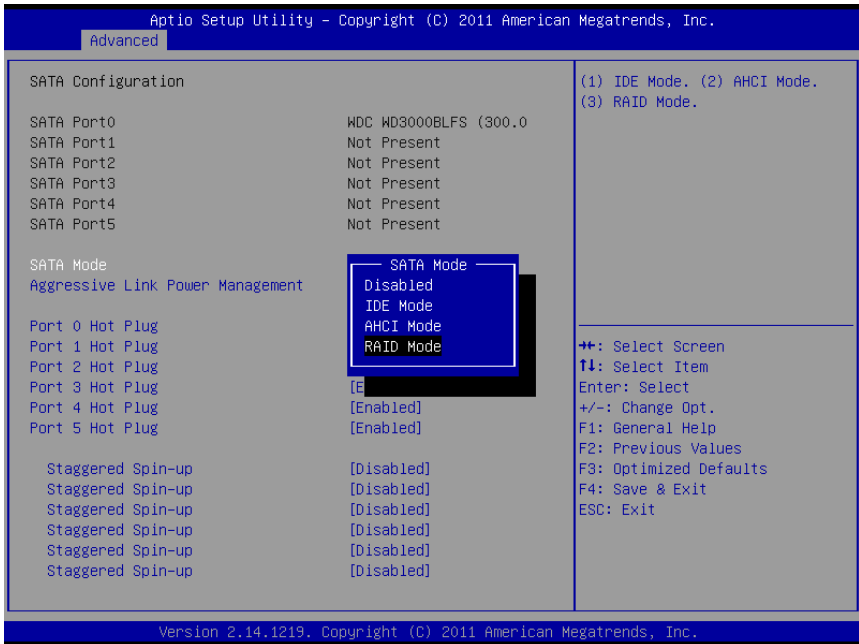
The number of physical drives in a specific array determines the possible RAID levels that you can implement with the array.

### ***Enabling SATA RAID in the BIOS***

Before installing the Windows Operating System, you must change some settings in BIOS. Boot up the system and hit the <Del> key to enter the BIOS Setup Utility. After the Setup Utility loads,

1. Use the arrow keys to move to the EXIT menu. Scroll down with the arrow keys to the LOAD OPTIMAL DEFAULTS setting and press <ENTER>. Select OK to confirm, then <ENTER> to load the default settings.
2. Use the arrow keys to move to the ADVANCED menu, then scroll down to SATA CONFIGURATION. Once in this submenu, scroll down to SATA MODE and choose the RAID MODE option (see [Figure 5-1](#)).
3. Hit the <ESC> key twice and scroll to the EXIT menu. Select SAVE CHANGES AND EXIT and hit <ENTER>, then hit <ENTER> again to verify.
4. After exiting the BIOS Setup Utility, the system will reboot. When prompted during the startup, press the <CTRL+A> key when prompted to run the Adaptec RAID Utility program (see [Figure 5-2](#)).

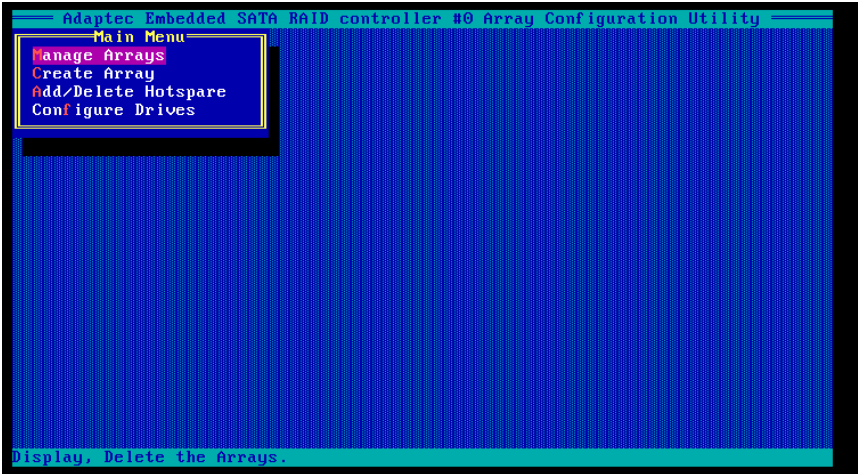
Figure 5-1. BIOS Setup Screen



## Using the Adaptec RAID Utility

The Adaptec® RAID Utility program is where you can define the drives you want to include in the RAID array and the mode and type of RAID. In the ADAPTEC RAID UTILITY PROGRAM screen (Figure 5-2) you can create an array, add hotspares and configure your drives.

Figure 5-2. Adaptec RAID Utility Program Screen



---

---

# Chapter 6

## BIOS

### 6-1 Introduction

This chapter describes the BIOS for Intel SuperBlade modules. The Intel Blade modules use a 64 MB SPI Flash EEPROM with AMI® BIOS™ that is stored in a flash chip. This BIOS can be easily upgraded using a floppy disk-based program.

**NOTE:** Due to periodic changes to the BIOS, some settings may have been added or deleted and might not yet be recorded in this manual. Please refer to the <http://www.supermicro.com/products/SuperBlade/module/> web site for further details on BIOS setup and the BIOS menus for your SuperBlade blade module.

#### System BIOS

BIOS stands for Basic Input Output System. The 64 MB SPI Flash EEPROM with AMI® BIOS flash chip stores the system parameters, types of disk drives, video displays, in the CMOS. The CMOS memory requires very little electrical power. When the blade unit is turned off, a backup battery provides power to the BIOS flash chip, enabling it to retain system parameters. Each time the blade is powered on it is configured with the values stored in the BIOS ROM by the system BIOS, which gains control at boot up.

#### How To Change the Configuration Data

The CMOS information that determines the system parameters may be changed by entering the BIOS Setup utility. This Setup utility can be accessed by pressing the <DELETE> key at the appropriate time during system boot. (See "Starting the Setup Utility" below.)

#### Starting the Setup Utility

Normally, the only visible POST (Power-On Self-Test) routine is the memory test. As the memory is being tested, press the <DELETE> key to enter the main menu of the BIOS Setup utility. From the main menu, you can access the other setup screens, such as the Security and Power menus.

**WARNING:** To prevent possible boot failure, do not shut down or reset the system while updating the BIOS.

## 6-2 BIOS Updates

It may be necessary to update the BIOS used in the blade modules on occasion. However, it is recommended that you not update BIOS if you are not experiencing problems with a blade module.

Updated BIOS files are located on our web site([www.supermicro.com/products/superblade/](http://www.supermicro.com/products/superblade/)). Please check the current BIOS revision and make sure it is newer than your current BIOS before downloading.

There are several methods you may use to upgrade (flash) your BIOS. After downloading the appropriate BIOS file (in a zip file format), follow one of the methods described below to flash the new BIOS.

### Flashing BIOS

Use the procedures below to “Flash” your BIOS with a new update using the KVM dongle, USB ports on the CMM module or by use of a Floppy disk.

#### ***Flashing a BIOS using the KVM Dongle:***

For this method, you must use a KVM “dongle” cable (CBL-0218L, included with the system).

1. Copy the contents of the zip file to a bootable USB pen drive.
2. Connect the KVM dongle (CBL-0218L) to the KVM connector at the front of the blade you will be flashing the BIOS to.
3. Connect your bootable USB pen drive to one of the two USB slots on the KVM dongle.
4. Boot to the USB pen drive and go to the directory where you saved the contents of the zip file.
5. Type **flash filename.rom** (replace *filename.rom* by the actual ROM file name).

#### ***Flashing a BIOS using the USB Ports on the CMM:***

1. Copy the contents of the zip file to a bootable USB pen drive.
2. Connect your bootable USB pen drive to one of the two USB slots on the CMM (located on the back side of the enclosure).
3. Boot to the USB pen drive and go to the directory where you saved the contents of the zip file.
4. Type **flash filename.rom** (replace *filename.rom* by the actual ROM file name).

#### ***Flashing a BIOS using a Floppy Image File***

This method must be performed remotely.

1. Copy the image file from the zip file to your desktop.
2. Use the web browser or IPMIView to access your CMM remotely using its IP Address.

3. Go to the VIRTUAL MEDIA menu and select FLOPPY IMAGE UPLOAD.
4. BROWSE or OPEN to locate the \*.img file on your desktop and select it.
5. Press the UPLOAD button and wait a few seconds for the image to upload to the CMM.
6. Once the upload finishes, turn on the blade module and press <DEL> to enter the BIOS setup utility.
7. In the BOOT MENU, bring **USB LS120: PEPPCMM VIRTUAL DISC 1** to the top of the boot priority list.
8. Exit while saving the changes. The blade module will boot to the virtual media (floppy image) **A:\>**.
9. Type **flash filename.rom**.

**NOTE:** Replace *filename.rom* by the actual ROM file name (such as **B8DTE142.rom** for example) in the command.

## 6-3 Running Setup

**NOTE:** Default settings are in **bold** text unless otherwise noted.

The BIOS setup options described in this section are selected by choosing the appropriate text from the MAIN BIOS SETUP screen. All displayed text is described in this section, although the screen display is often all you need to understand how to set the options.

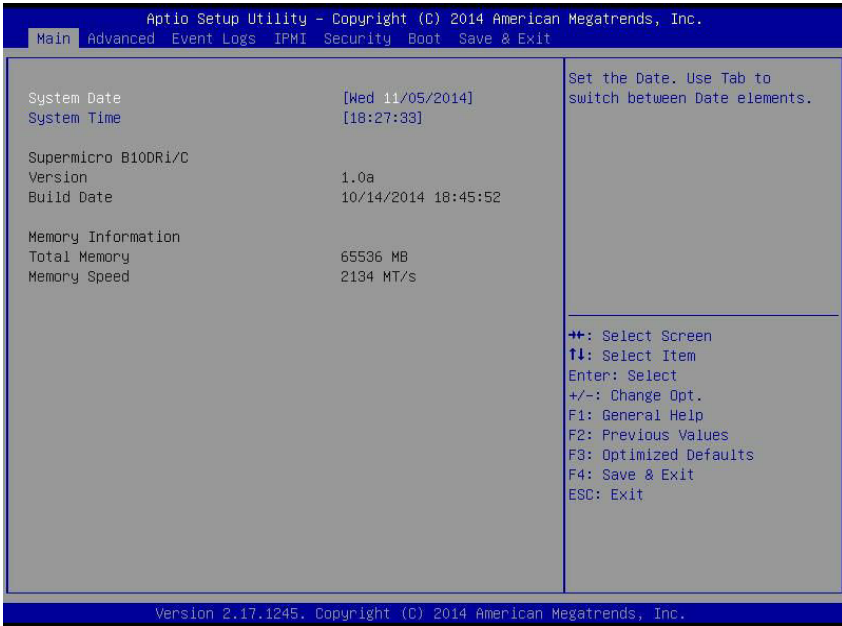
When you first power on the computer, the BIOS is immediately activated.

While the BIOS is in control, the Setup program can be activated in one of two ways:

1. By pressing <DELETE> immediately after turning the system on, or
2. When the message **Press the <Delete> key to enter Setup** appears briefly at the bottom of the screen during the POST, press the <DELETE> key to activate the main SETUP menu:

## 6-4 Main BIOS Setup

Figure 6-1. BIOS Setup Screen



All Main Setup options are described in this section.

Use the UP/DOWN arrow keys to move among the different settings in each menu. Use the LEFT/RIGHT arrow keys to change the options for each setting.

Press the <ESC> key to exit the CMOS SETUP menu. The next section describes in detail how to navigate through the menus.

Items that use sub-menus are indicated with the ► icon. With the item highlighted, press the <ENTER> key to access the submenu.

Menu options found in the MAIN BIOS SETUP menu are described in [Table 6-1](#).

Table 6-1. Main BIOS Setup Menu Options

Menu Option	Description
System Date	Using the arrow keys, highlight the month, day and year fields, and enter the correct data for the system date. Press the <Enter> key to save the data.
System Time	To set the system date and time, key in the correct information in the appropriate fields. Then press the <Enter> key to save the data.
BIOS Information	BIOS static display information including the serverboard number, SMC version, SMC Build Date and Total Memory is also shown on the screen.

## 6-5 Advanced Setup

Choose **Advanced** from the BIOS Setup Utility main menu with the arrow keys to display the **ADVANCED SETUP** menu. The items with a triangle beside them are sub-menus that can be accessed by highlighting the item and pressing <ENTER>. Options for PIR settings are displayed by highlighting the setting option using the arrow keys and pressing <ENTER>.

Table 6-2 describes all sub-menus found in the **ADVANCED SETUP** menu.

**Table 6-2. Advanced Setup Menu Options**

Sub-menu	Description
▶ Boot Feature	See Table 6-3 for a description of BIOS setup menu options in this sub-menu.
▶ CPU Configuration	See Table 6-4 for a description of BIOS setup menu options in this sub-menu.
▶ Chipset Configuration	See Table 6-5 for a description of BIOS setup menu options in this sub-menu.
▶ SATA Configuration	See Table 6-6 for a description of BIOS setup menu options in this sub-menu.
▶ sSATA Configuration	See Table 6-7 for a description of BIOS setup menu options in this sub-menu.
▶ Server ME Configuration	See Table 6-8 for a description of BIOS setup menu options in this sub-menu.
▶ PCIe/PII/PnP Configuration	See Table 6-9 for a description of BIOS setup menu options in this sub-menu.
▶ Super IO Configuration	See Table 6-10 for a description of BIOS setup menu options in this sub-menu.
▶ Serial Port Console Redirection	See Table 6-11 for a description of BIOS setup menu options in this sub-menu.
▶ ACPI Configuration	See Table 6-12 for a description of BIOS setup menu options in this sub-menu.
▶ iSCSI Configuration	

**Table 6-3. Boot Feature Submenu**

Menu Option	Description
Quiet Boot	When Disabled the BIOS displays normal POST messages. When <b>Enabled</b> the BIOS displays an OEM Logo instead of POST messages.
AddOn ROM Display Mode	This setting sets the display mode for Option ROM. Options include <b>Force BIOS</b> or <b>Keep Current</b> .
Bootup NUM-Lock	This setting selects the Power-On state for Numlock. Options include <b>On</b> or <b>Off</b> .

**Table 6-3. Boot Feature Submenu (Continued)**

Menu Option	Description
Wait for 'F1' If Error	When enabled, the system will wait for the F1 key to be pressed if an error occurs. Options are <b>Enabled</b> or Disabled.
Interrupt 19 Capture	When enabled this setting allows option ROMs to trap Interrupt 19. Options include <b>Immediate</b> or Postponed.
Watch Dog Function	This setting allows the system to restart when it is not active more than 5 minutes. Option include Enabled and <b>Disabled</b> .
Power Button Function	This setting specifies the power button's function when pressed. Option include 4 Seconds Override or <b>Instant Off</b> .
Restore on AC Power Loss	This setting specifies what the system will do when power is restored after an AC power loss to the system. Options include <b>Stay Off</b> (system power remains off after power loss), Power-On (system power turns on after power loss) or Last State (allows the system to resume its last state before the power loss).

**Table 6-4. CPU Configuration Submenu**

Menu Option	Description
CPU Information	CPU Information is statically shown here for both processors in your system.
Clock Spread Spectrum	This setting enables or disables spread spectrum modulation. Options are Enabled and <b>Disabled</b> .
Hyper-threading (ALL)	This setting is <b>Enabled</b> for Windows XP and Linux (OS optimized for Hyper-threading technology), and Disabled for other OSes (any OS not optimized for Hyper-threading technology). When Disabled, only one thread per enabled core is enabled.
Cores Enabled	Use this setting to specify the CPU cores to enable for your system. This is specified by a number from 0 to 12. Specifying "0" means all cores are enabled. 12 cores are available.
Execute Disable Bit	XD can prevent certain classes of malicious buffer overflow attacks when combined with a supporting OS such as Windows Server 2003 SP1, Windows XP SP2, SuSE Linux 9.2 or RedHat Enterprise 3 Update 3. Options include <b>Enabled</b> or Disabled.
PPIN Control	Use this setting to unlock and enable/disable PPIN control. Options include Unlock/Disable and <b>Unlock/Enable</b> .
Hardware Prefetcher	If set to <b>Enabled</b> , the hardware prefetcher will prefetch streams of data and instructions from the main memory to the L2 cache in the forward or backward manner to improve CPU performance. Options are <b>Enabled</b> and Disabled. For UP platforms leave it enabled. for DP/MP servers, this setting may be used to tune performance to the specific application.
Adjacent Cache Line Prefetch	The CPU fetches the cache line for 64-bytes if this option is set to Disabled. The CPU fetches both cache lines for 128-bytes as comprised if <b>Enabled</b> . For UP platforms leave it enabled. for DP/MP servers, this setting may be used to tune performance to the specific application.

Table 6-4. CPU Configuration Submenu (Continued)

Menu Option	Description
DCU Streamer Prefetcher	For UP platforms, leave this option <b>Enabled</b> . For DP/MP servers, this option may be used to tune performance to the specific application. Options are <b>Enabled</b> or <b>Disabled</b> .
DCU IP Prefetcher	This setting <b>Enables</b> or <b>Disables</b> prefetch of the next L1 line based upon sequential load history.
Direct Cache Access (DCA)	Use this setting to enable Direct Cache Access. Options include <b>Disable</b> , <b>Enable</b> or <b>Auto</b> .
X2APIC	Use this setting to <b>Enable</b> or <b>Disable</b> extended APIC support.
AES-NI	Use this setting to <b>Enable</b> or <b>Disable</b> AES-NI support.
Intel® Virtualization Technology	Select <b>Enabled</b> to use this Virtualization Technology feature to allow one platform to run multiple operating systems and applications in independent partitions, creating multiple "virtual" systems in one physical computer system. The options are <b>Enabled</b> and <b>Disabled</b> . Please refer to the <a href="#">Intel website</a> for further detailed information. <b>NOTE:</b> A full reset of the system is required when you change this setting.
►Advanced Power Management Configuration	Power management options and information is displayed on this submenu. In addition to the options in this submenu, information is displayed for Factory Long Duration Power Limit, Factory Long Duration Maintained and Recommended Short Duration Power.
Power Technology	This option enables power management features. Options include <b>Disable</b> , <b>Energy Efficient</b> and <b>Custom</b> . Selecting "Custom" allows you to either <b>Enable</b> or <b>Disable</b> the following sub-menus and their settings: <ul style="list-style-type: none"> <li>• CPU P State Control</li> <li>• CPU C State Control</li> <li>• CPU T State Control</li> </ul>
►CPU P State Control	This sub-menu allows you to configure CPU P State Control settings.
EIST (P-States)	When this setting is <b>Enabled</b> , the OS sets CPU frequency according to the load. When <b>Disabled</b> , the CPU frequency is set at maximum non-turbo.
Turbo Mode	Turbo mode allows a CPU logical processor to execute a higher frequency when enough power is available to not exceed CPU defined limits. Options include <b>Enabled</b> and <b>Disabled</b> .
P-state Coordination	Use this setting to configure P-state coordination. Options include <b>HW_ALL</b> , <b>SW_ALL</b> and <b>SW_ANY</b> . <b>HW_ALL</b> (hardware) coordination is recommended over <b>SW_ALL</b> and <b>SW_ANY</b> (software coordination).
►CPU C State Control	This sub-menu allows you to configure CPU C State Control settings.
Package C State Limit	Use this setting to specify the Package C State Limit. Options include <b>C0/C1 State</b> , <b>C2 State</b> , <b>C6 (non-retention) State</b> , <b>C6 (Retention) State</b> , <b>No Limit</b> .
CPU C3 Report	This setting allows you to <b>Disable</b> or <b>Enable</b> the CPU C3 (ACPI C2) report to the OS. It is recommended that this setting be disabled.

**Table 6-4. CPU Configuration Submenu (Continued)**

Menu Option	Description
CPU C6 Report	This setting allows you to Disable or <b>Enable</b> the CPU C3 (ACPI C2) report to the OS. It is recommended that this setting be enabled.
Enhanced Halt State (C1E)	Use this setting to enable the Enhanced C1E State of the CPU. This only takes effect after a reboot of the system. Options include <b>Enabled</b> or Disabled.
▶CPU T State Control	This sub-menu allows you to configure CPU T State Control settings.
ACPI T-States	Use this setting to <b>Enable</b> or Disable CPU throttling by the OS in order to reduce power consumption.
▶Socket RAPL Config	This sub-menu allows you to configure Socket RAPL Configuration settings.
FAST_RAPL_NSTRIKE_PL2_DUTY_CYCLE	This setting provides you a FAST_RAPL_NSTRIKE_PL2_DUTY_CYCLE value between 25 (10%) - <b>64</b> (25%). Use the "+" or "-" key on your keyboard's number pad to select a value.
Turbo Pwr Limit Lock	Use this setting to Enable or <b>Disable</b> the locking of the turbo settings. When enabled, the TURBO_POWER_LIMIT MSR will be locked and a reset will be required to unlock the register.
Long Pwr Limit Ovrđ	Use this setting to <b>Enable</b> or Disable Long Term Power Limit override. If this option is disabled, the BIOS will program the default values for Long Duration Power Limit and Long Duration Time Window settings.
Long Dur Pwr Limit	This setting is for the Turbo Mode Long Duration Power Limit (Power Limit 1) in Watts. The value may vary from <b>0</b> to Fused value. If the value is 0, then the fused value will be programmed. A value greater than fused TDP value will not be programmed. Use the "+" or "-" key on your keyboard's number pad to select a value.
Long Dur Time Window	This setting is for the Long Duration Time Window (Power Limit 1) value in seconds. The value may vary from 0 to 56, with the default being <b>1</b> . This setting indicates the time window over which the TDP value should be maintained. If the value is 0, the Fused value will be programmed. Use the "+" or "-" key on your keyboard's number pad to select a value.
Pkg Clmp Lim1	This setting is for the Packaging Clamping Limit1. You may specify the value to be between P1 and P0 or <b>Below P1</b> for this setting.
Short Dur Pwr Limit En	Use this setting to <b>Enable</b> or Disable the Short Duration Power Limit (Power Limit 2).
Short Dur Pwr Limit	Use this setting to specify the Short Duration Power Limit (Power Limit 2) value in Watts. The value may vary from <b>0</b> to 32767. Use the "+" or "-" key on your keyboard's number pad to select a value. If the value is 0, the BIOS will program this value as 125%*TDP. The processor applies the control policies such that the package power does not exceed this limit.
Pkg Clmp Lim2	This setting is for the Packaging Clamping Limit2. You may specify the value to be between P1 and P0 or <b>Below P1</b> for this setting.

Table 6-4. CPU Configuration Submenu (Continued)

Menu Option	Description
▶DRAM RAPL Configuration	This sub-menu allows you to configure DRAM RAPL Configuration settings.
DRAM RAPL Baseline	This setting allows you to enable the DRAM RAPL Baseline and its mode. Options include Disable, DRAM RAPL Mode 0 and <b>DRAM RAPL Mode 1</b> .
Override BW_LIMIT_TF	This setting allows you to custom tune BW_LIMIT_TF when DRAM RAPL is enabled. Use the "+" or "-" key on your keyboard's number pad to select a value.
DRAM RAPL Extended Range	Use this setting to <b>Enable</b> or Disable the DRAM RAPL Extended Range for your system.

Table 6-5. Chipset Configuration Sub-menu

Menu Option	Description
▶North Bridge Configuration	This sub-menu configures North Bridge features and shows configuration information.
▶IOH Configuration	This submenu configures Intel VT-d and Intel I/OAT in your system and configures IOU PCIe port bifurcation controls.
EV DFX Features	Use this setting to <b>Enable</b> or Disable allowing DFX Lock Bits to remain clear.
▶IIO0 Configuration	This sub-menu allows you to set IIO0 Configuration.
IOU2 (IIO PCIe Port 1)	Selects PCIe port Bifurcation for PCIe Port 1. Options include x4x4, x8 or <b>Auto</b> .
IOU0 (IIO PCIe Port 2)	Selects PCIe port Bifurcation for PCIe Port 2. Options include x4x4x4x4, x4x4x8, x8x4x4, <b>x8x8</b> , x16 or Auto.
IOU1 (IIO PCIe Port 3)	Selects PCIe port Bifurcation for PCIe Port 3. Options include <b>x4x4x4x4</b> , x4x4x8, x8x4x4, x8x8, x16 or Auto.
No PCIe port active ECO	Use this for workaround settings when no PCIe port is active. Options include <b>PCU Squelch Exit Ignore Option</b> or Reset the SQ FLOP by CSR Option.
▶Socket 0 PCIED00F0 - Port 0/DMI	Use this submenu for settings related to PCI Express Ports.
Link Speed	This setting specifies the link speed for the PCI-E port. Options include <b>Auto</b> , Gen 1 (2.5 GT/s) or Gen 2 (5 GT/s)
PCI-E Port DeEmphasis	This setting allows you to de-emphasize control for this PCI-E port. Options include <b>-6.0 dB</b> or -3.5 dB.
PCI-e Port Link Information	This is static information for your PCI-E link and includes PCI-E Port Link Status, PCI-E Port Link Max and PCI-E Port Link Speed.
PCI-E Port L0s Exit Latency	This setting allows you to specify the length of time this port requires to complete transition from L0s to L0. The default and only option is <b>4uS-8uS</b> .

Table 6-5. Chipset Configuration Sub-menu (Continued)

Menu Option	Description
PCI-E Port L1 Exit Latency	This setting allows you to specify the length of time this port requires to complete transition from L1 to L0. The options include <1uS, 1uS - 2uS, 2uS - 4uS, 4uS - 8uS, <b>8uS - 16uS</b> , 16uS - 32uS, 32uS - 64uS and >64uS.
Fatal Err Over	This setting enables you to force fatal error propagation to the IIO core error logic for this port. Options include Enable and <b>Disable</b> .
Non-Fatal Err Over	This setting enables you to force non-fatal error propagation to the IIO core error logic for this port. Options include Enable and <b>Disable</b> .
Corr Err Over	This setting enables you to force correctable error propagation to the IIO core error logic for this port. Options include Enable and <b>Disable</b> .
LOs Support	When this setting is <b>Disabled</b> , the IIO never puts its transmitter in the Los state.
▶ IIO1 Configuration	This sub-menu configures Integrated I/O 1 Configuration.
IIOU2 (IIO PCIe Port 1)	This setting selects the PCIe port bifurcation for PCIe Slot 1. Options include x4x4, x8 or <b>Auto</b> .
IIOU0 (IIO PCIe Port 2)	This setting selects the PCIe port bifurcation for PCIe Slot 2. Options include <b>x4x4x4x4</b> , x4x4x8, x8x4x4, x8x8, x16 or Auto.
IIOU1 (IIO PCIe Port 3)	This setting selects the PCIe port bifurcation for PCIe Slot 3. Options include x4x4x4x4, x4x4x8, x8x4x4, x8x8, x16 or <b>Auto</b> .
No PCIe Port Active ECO	This setting is a workaround setting when no PCIe port is active. Options include <b>PCU Squelch Exit Ignore Option</b> and Reset the SQ FLOP by CSR Option.
▶ IOAT Configuration	This sub-menu configures all IOAT configuration options.
Enable IOAT	This setting allows you <b>Enable</b> or Disable IOAT devices.
No Snoop	Use this setting to Enable or <b>Disable</b> No Snoop for each CB device.
Relaxed Ordering	This setting Enables or <b>Disables</b> relaxed ordering in your system.
▶ Intel VT for Directed I/O (VT-d)	This sub-menu allows you to configure Intel VT for Directed I/O settings.
Intel VT for Directed I/O (VT-d)	This setting allows you to <b>Enable</b> or Disable Intel Virtualization Technology for Directed I/O (VT-d) by reporting the I/O device assignment to VMM through the DMAR ACPI Tables.
Interrupt Remapping	This setting allows you to <b>Enable</b> or Disable VT_D Interrupt Remapping Support.
▶ QPI Configuration	This sub-menu allows you to configure QPI settings.
▶ QPI General Configuration	This sub-menu displays and provides options to change the QPI General settings.
▶ QPI Status	Selecting this sub-menu brings up a screen showing QPI Status static information including Number of CPU, Number of IIO, Current QPI Link Speed, Current QPI Link Frequency, QPI Global MMIO Low Base / Limit, QPI Global MMIO High Base / Limit and QPI Pci-e Configuration Base / Size.

Table 6-5. Chipset Configuration Sub-menu (Continued)

Menu Option	Description
Link Frequency Select	This setting allows you to select the QPI Link Frequency. Options include 6.4GB/s, 8.0GB/s, 9.6GB/s, <b>Auto</b> and Auto Limited.
Link L0p Enable	This setting <b>Enables</b> or Disables Link L0p.
Link L1 Enable	This setting <b>Enables</b> or Disables Link L1.
COD Enable	This setting Enables or <b>Disables</b> Cluster on Die for the system.
Early Snoop	This setting enables or disables Early Snoop for the system. Options include Disable, Enable or <b>Auto</b> .
Isoc Mode	This setting allows you to Enable or <b>Disable</b> Isoc in your system.
►Memory Configuration	This sub-menu displays Memory Configuration settings.
Enforce POR	This setting allows you to enforce POR restrictions for DDR4 frequency and voltage programming. Options include <b>Enabled</b> or Disabled.
Memory Frequency	This sets the maximum memory frequency in Mhz. Options include <b>Auto</b> and frequencies between 1333 ~ 3200. <b>WARNING! DO NOT SELECT RESERVED.</b>
Data Scrambling	Use this setting to enable data scrambling for your system. Options include <b>Auto</b> , Disabled and Enabled.
DRAM RAPL Baseline	This setting enables and specifies the DRAM RAPL Baseline mode. Options include Disable, DRAM RAPL Mode 0 and <b>DRAM RAPL Mode 1</b> .
Set Throttling Mode	This setting sets the Thermal Throttling mode for your system to either Disabled or <b>CLTT</b> .
Socket Interleave Below 4GB	This setting splits the 0-4GB address space between two sockets, so that both sockets get a chunk of the local memory below 4GB. Options include <b>Disable</b> or Enable.
A7 Mode	This setting <b>Enables</b> or Disables A7 mode in your system.
►DIMM Information	Static DIMM presence and size information is shown when this sub-menu is selected.
►Memory RAS Configuration	This sub-menu displays and provides settings to change Memory RAS.
RAS Mode	This setting Enables or <b>Disables</b> RAS Mode. Enabled Sparing and Mirroring is not supported. If enabled, Sparing will be selected.
Memory Rank Sparing	This setting Enables or <b>Disables</b> Memory Rank Sparing in your system.
Patrol Scrub	This setting <b>Enables</b> or Disables Patrol Scrub in your system.
Patrol Scrub Interval	This setting selects the number of hours (1-24) required to complete full scrub. A value of 0 means auto. Default is <b>24</b> . Settings are increased or decreased using the "+" or "-" keys on your keyboard's number pad.
Demand Scrub	This setting <b>Enables</b> or Disables Demand Scrub in your system.

**Table 6-5. Chipset Configuration Sub-menu (Continued)**

Menu Option	Description
Device Tagging	This setting Enables or <b>Disables</b> Device Tagging in your system.
► South Bridge Configuration	This sub-menu allows you to configure South Bridge parameters.
USB Information	Static information for USB Module Version and USB devices connected is shown at the top of this screen.
Legacy USB Support	This setting allows you to enable the use of Legacy USB devices. If this option is set to Auto, legacy USB support will be automatically enabled if a legacy USB device is installed on the mainboard, and disabled if no USB devices are connected. The Disable option will keep USB devices available only for EFI applications. The options include Disabled, <b>Enabled</b> and Auto.
XHCI Hand-off	This is a workaround for OSES without XHCI hand-off support. The XHCI ownership change should be claimed by the XHCI driver. Options include <b>Enabled</b> and Disabled.
EHCI Hand-off	This setting is a workaround for OSES without EHCI hand-off support. The EHCI ownership change should be claimed by the EHCI driver. Options include Enabled or <b>Disabled</b> .
Port 60/64 Emulation	This setting <b>Enables</b> or Disables I/O port 60h/64h emulation support. This should be enabled for the complete USB keyboard legacy support for non-USB aware OSES.
USB 3.0 Support	This setting enables or disables USB 3.0 Support. Options include Smart Auto, Auto, Enabled or <b>Disabled</b> .
EHCI1	This setting controls the USB EHCI (USB 2.0) functions for EHCI1. One of these EHCI controllers must always be enabled. Options include <b>Enabled</b> or Disabled.
EHCI2	This setting controls the USB EHCI (USB 2.0) functions for EHCI2. One of these EHCI controllers must always be enabled. Options include <b>Enabled</b> or Disabled.

**Table 6-6. SATA Configuration Sub-menu**

Menu Option	Description
SATA Controller	This setting allows you to <b>Enable</b> or Disable the SATA device.
Configure SATA as	Use this setting to select the SATA mode you desire. Options include IDE, <b>AHCI</b> and RAID.
Support Aggressive Link Power Mana	Use this setting to <b>Enable</b> or Disable SALP.
SATA Port 0-5 Settings	For each of the ports you may configure the settings listed below.
Spin Up Device	This setting allows you to Enable or <b>Disable</b> the Spin up Device for the system. If enabled for any ports staggered spin up will be performed and only the drives that have this option enabled will spin up at boot. Otherwise all drives spin up at boot if this setting is disabled.
SATA Device Type	This setting allows you to identify that the SATA port is connected to either a Solid State Drive or a <b>Hard Disk Drive</b> .

**Table 6-7. sSATA Configuration Sub-menu**

Menu Option	Description
sSATA Controller	This setting allows you to <b>Enable</b> or Disable the SATA controller.
Configure sSATA as	Use this setting to select the SATA mode you desire. Options include IDE, <b>AHCI</b> and RAID.
Support Aggressive Link Power Mana	Use this setting to <b>Enable</b> or Disable SALP.
sSATA Port 0~3 Settings	For each of the ports you may configure the settings listed below.
Spin Up Device	This setting allows you to Enable or <b>Disable</b> the Spin up Device for the system. If enabled for any ports staggered spin up will be performed and only the drives that have this option enabled will spin up at boot. Otherwise all drives spin up at boot if this setting is disabled.
SATA Device Type	This setting allows you to identify that the SATA port is connected to either a Solid State Drive or a <b>Hard Disk Drive</b> .

**Table 6-8. Server ME Information Sub-menu**

Menu Option	Description
General ME Configuration Information	General ME configuration information is displayed at the top of this screen.
Altitude	The altitude of the platform location above sea level, expressed in meters, is set using the keyboard's number pad "+" or "-" keys. Use the default <b>8000000</b> value if the altitude is unknown.
MCTP Bus Owner	This setting is for specifying the MCTP bus owner location on PCIe. Values can be [15:8] bus, [7:3] device or [2:0] function. If <b>0</b> , then the sending bus owner is disabled.

**Table 6-9. PCIe/PCI/PnP Configuration Sub-menu**

Menu Option	Description
PCI Latency Timer	Use this feature to set the latency Timer of each PCI device installed on a PCI bus. Select 32 to set the PCI latency to 32 PCI clock cycles. The options are <b>32 PCI Bus Clocks</b> , 64 PCI Bus Clocks, 96 PCI Bus Clocks, 128 PCI Bus Clocks, 160 PCI Bus Clocks, 192 PCI Bus Clocks, 224 PCI Bus Clocks and 248 PCI Bus Clocks.
PERR# Generation	Select Enabled to allow a PCI device to generate a PERR number for a PCI Bus Signal Error Event. The options are <b>Disabled</b> and Enabled.
SERR# Generation	Select Enabled to allow a PCI device to generate an SERR number for a PCI Bus Signal Error Event. The options are <b>Enabled</b> and Disabled.
PCI PERR/SERR Support	This setting Enables or <b>Disables</b> the runtime event for SERR/PERR errors.

**Table 6-9. PCIe/PCI/PnP Configuration Sub-menu (Continued)**

Menu Option	Description
Above 4G Decoding (Available if the system supports 64-bit PCI decoding)	Select Enabled to decode a 64-bit PCI device in the space above 4G Address. The options are Enabled and <b>Disabled</b> .
SR-IOV Support	If the system has SR-IOV capable PCIe device, this option Enables or <b>Disables</b> single root I/O virtualization support.
Maximum Payload	Select Auto to allow the system BIOS to automatically set the maximum payload value for a PCI-E device to enhance system performance. The options are <b>Auto</b> , 128 Bytes, 256 Bytes, 512 Bytes, 1024 Bytes, 2048 Bytes, and 4096 Bytes.
Maximum Read Request	Select Auto to allow the system BIOS to automatically set the maximum Read Request size for a PCI-E device to enhance system performance. The options are <b>Auto</b> , 128 Bytes, 256 Bytes, 512 Bytes, 1024 Bytes, 2048 Bytes, and 4096 Bytes.
ASPM Support	This feature allows the user to set the Active State Power Management (ASPM) level for a PCI-E device. Select Force L0 to force all PCI-E links to operate at L0 state. Select Auto to allow the system BIOS to automatically set the ASPM level for the system. Select Disabled to disable ASPM support. The options are <b>Disabled</b> , Force L0, and Auto. Enabling ASPM support may cause some PCI-E devices to fail!
MMIOHBase	This setting must specify a number between 4032 - 4078. Options include <b>56T</b> , 48T, 24T, 2T, 512G and 256G.
MMIO High Size	This setting allocates MMIOH size per CPU. Options include <b>256G</b> , 128G, 512G and 1024G.
CPU1 Slot 1 PCI-E OPROM	This setting enables or disables the PCIe Slot OPROM option. Options include Disabled, <b>Legacy</b> or EFI.
Onboard Video OPROM	Use this setting to control the execution of UEFI and Legacy Video OPROM on your system. Options include Disabled, <b>Legacy</b> or EFI.
VGA Priority	This setting decides the priority between <b>Onboard</b> and the first Offboard video device found.
Onboard LAN Option ROM Type	Select the onboard LAN option ROM type from this setting. Options include <b>Legacy</b> and EFI.
Onboard LAN 1 OPROM	This setting enables or disables Onboard LAN 1 Option ROM. Options include <b>PXE</b> , iSCSI or Disabled.
Onboard LAN 2 OPROM	This setting enables or disables Onboard LAN 2 Option ROM. Options include PXE or <b>Disabled</b> .
Network Stack	This setting Enables or <b>Disables</b> the UEFI Network Stack.

**Table 6-10. SuperIO Device Configuration Sub-menu**

Menu Option	Description
Super IO Chip	This static display shows the name of the Super IO chip installed for your system.
► Serial Port 1/2 Configuration	This sub-menu allows the user the configure settings of Serial Port 1 or Serial Port 2.
Serial Port	Select Enabled to enable the a selected onboard serial port. The options are <b>Enabled</b> and Disabled.
Device Settings	This item displays the status of a serial part specified by the user.
Change Settings (Available for Serial Port 2 only)	This feature specifies the base I/O port address and the Interrupt Request address of a serial port specified by the user. Select Auto to allow the BIOS to automatically assign the base I/O and IRQ address. The options for Serial Port 1 are <b>Auto</b> , (IO=3F8h; IRQ=4), (IO=3F8h; IRQ=3, 4, 5, 6, 7, 9, 10, 11, 12), (IO=2F8h; IRQ=3, 4, 5, 6, 7, 9, 10, 11, 12), (IO=3E8h; IRQ=3, 4, 5, 6, 7, 9, 10, 11, 12) and (IO=2E8h; IRQ=3, 4, 5, 6, 7, 9, 10, 11, 12). The options for Serial Port 2 are <b>Auto</b> , (IO=2F8h; IRQ=3), (IO=3F8h; IRQ=3, 4, 5, 6, 7, 9, 10, 11, 12), (IO=2F8h; IRQ=3, 4, 5, 6, 7, 9, 10, 11, 12), (IO=3E8h; IRQ=3, 4, 5, 6, 7, 9, 10, 11, 12) and (IO=2E8h; IRQ=3, 4, 5, 6, 7, 9, 10, 11, 12).
Device Mode	Use this feature to set the optimal setting for a super I/O device. The options are <b>24MHz/13</b> and 24MHz.
Serial Port 2 Attribute (Available for Serial Port 2 only)	This feature specifies the attribute of Serial Port 1. The options are <b>SOL</b> and COM.

**Table 6-11. Serial Port Console Redirection Sub-menu**

Menu Option	Description
<b>COM1 Console Redirection, COM2/SOL/Legacy Console Redirection Sub-menus</b>	
Console Redirection	Select Enabled to enable console redirection support for a serial port specified by the user. The options are Enabled and <b>Disabled</b> .
► Console Redirection Settings	This feature allows the user to specify how the host computer will exchange data with the client computer, which is the remote computer used by the user.
Terminal Type	This feature allows the user to select the target terminal emulation type for Console Redirection. Select VT100 to use the ASCII Character set. Select VT100+ to add color and function key support. Select ANSI to use the Extended ASCII Character Set. Select VT-UTF8 to use UTF8 encoding to map Unicode characters into one or more bytes. The options are ANSI, VT100, <b>VT100+</b> , and VT-UTF8.
Bits Per second	Use this feature to set the transmission speed for a serial port used in Console Redirection. Make sure that the same speed is used in the host computer and the client computer. A lower transmission speed may be required for long and busy lines. The options are 9600, 19200, 38400, 57600 and <b>115200</b> (bits per second).
Data Bits	Use this feature to set the data transmission size for Console Redirection. The options are 7 Bits and <b>8 Bits</b> .

**Table 6-11. Serial Port Console Redirection Sub-menu (Continued)**

Menu Option	Description
Parity	A parity bit can be sent along with regular data bits to detect data transmission errors. Select Even if the parity bit is set to 0, and the number of 1's in data bits is even. Select Odd if the parity bit is set to 0, and the number of 1's in data bits is odd. Select None if you do not want to send a parity bit with your data bits in transmission. Select Mark to add a mark as a parity bit to be sent along with the data bits. Select Space to add a Space as a parity bit to be sent with your data bits. The options are <b>None</b> , Even, Odd, Mark and Space.
Stop Bits	A stop bit indicates the end of a serial data packet. Select 1 Stop Bit for standard serial data communication. Select 2 Stop Bits if slower devices are used. The options are <b>1</b> and <b>2</b> .
Flow Control	Use this feature to set the flow control for Console Redirection to prevent data loss caused by buffer overflow. Send a "Stop" signal to stop sending data when the receiving buffer is full. Send a "Start" signal to start sending data when the receiving buffer is empty. The options are <b>None</b> and Hardware RTS/CTS.
VT-UTF8 Combo Key Support	Select Enabled to enable VT-UTF8 Combination Key support for ANSI/VT100 terminals. The options are <b>Enabled</b> and Disabled.
Recorder Mode	Select Enabled to capture the data displayed on a terminal and send it as text messages to a remote server. The options are <b>Disabled</b> and Enabled.
Resolution 100x31	Select Enabled for extended-terminal resolution support. The options are Disabled and <b>Enabled</b> .
Legacy OS Redirection Resolution	Use this feature to select the number of rows and columns used in Console Redirection for legacy OS support. The options are 80x24 and <b>80x25</b> .
Putty KeyPad	This feature selects the settings for Function Keys and KeyPad used for Putty, which is a terminal emulator designed for the Windows OS. The options are <b>VT100</b> , LINUX, XTERMR6, SC0, ESCN, and VT400.
Redirection After BIOS Post	Use this feature to enable or disable legacy console redirection after BIOS POST. When set to Bootloader, legacy console redirection is disabled before booting the OS. When set to Always Enable, legacy console redirection remains enabled when booting the OS. The options are <b>Always Enable</b> and Bootloader.
Legacy Serial Redirection Port (for Legacy Console Redirection only)	Use this setting to select a COM port to display redirection of Legacy OS and Legacy OPROM messages. Options include <b>COM1 Console Redirection</b> or COM2/SOL Console Redirection.
<b>Serial Port for Out-of-Band Management/Windows Emergency Management Services (EMS)</b>	
Console Redirection (for EMS)	Select Enabled to use a COM Port selected by the user for Console Redirection. The options are Enabled and <b>Disabled</b> .
► Console Redirection Settings (for EMS)	This feature allows the user to specify how the host computer will exchange data with the client computer, which is the remote computer used by the user.
Out-of-Band Management Port	The feature selects a serial port used by the Microsoft Windows Emergency Management Services (EMS) to communicate with a remote server. The options are <b>COM1 Console Redirection</b> and COM2/SOL Console Redirection.

**Table 6-11. Serial Port Console Redirection Sub-menu (Continued)**

Menu Option	Description
Terminal Type	This feature allows the user to select the target terminal emulation type for Console Redirection. Select VT100 to use the ASCII character set. Select VT100+ to add color and function key support. Select ANSI to use the extended ASCII character set. Select VT-UTF8 to use UTF8 encoding to map Unicode characters into one or more bytes. The options are ANSI, VT100, VT100+, and <b>VT-UTF8</b> .
Bits Per Second	This item sets the transmission speed for a serial port used in Console Redirection. Make sure that the same speed is used in the host computer and the client computer. A lower transmission speed may be required for long and busy lines. The options are 9600, 19200, 57600, and <b>115200</b> (bits per second).
Flow Control	This feature allows the user to set the flow control for Console Redirection to prevent data loss caused by buffer overflow. Send a "Stop" signal to stop sending data when the receiving buffer is full. Send a "Start" signal to start sending data when the receiving buffer is empty. The options are <b>None</b> , Hardware RTS/CTS, and Software Xon/Xoff.
Data Bits, Parity, Stop Bits	The status of each item above is displayed.

**Table 6-12. ACPI Settings Sub-menu**

Menu Option	Description
WHEA Support	This feature Enables the Windows Hardware Error Architecture (WHEA) support for the Windows 2008 (or a later vision) operating system. The options are <b>Enabled</b> and Disabled.
High Precision Event Timer	Select Enabled to activate the High Performance Event Timer (HPET) that produces periodic interrupts at a much higher frequency than a Real-time Clock (RTC) does in synchronizing multimedia streams, providing smooth playback and reducing the dependency on other timestamp calculation devices, such as an x86 RDTSC Instruction embedded in the CPU. The High Performance Event Timer is used to replace the 8254 Programmable Interval Timer. The options are <b>Enabled</b> and Disabled.
NUMA	Use this setting to <b>Enable</b> or Disable NUMA.
PCI AER Support	This setting allows you to Enable or <b>Disable</b> PCI AER Support.

**Table 6-13. iSCSI Configuration Sub-menu**

Menu Option	Description
iSCSI Initiator Name	Use this setting to enter a unique name of the iSCSI Initiator. Only IQN format is accepted. Range is from 4 to 223.

## 6-6 Event Logs Setup

Choose **Event Logs Setup** from the BIOS Setup main menu with the arrow keys to bring up the EVENT LOGS SETUP menu. Event Logs setup options are displayed by highlighting the setting using the arrow keys and pressing <ENTER>. All Event Logs Setup BIOS settings are described in [Table 6-14](#) below.

**Table 6-14. Event Logs Menu**

Menu Option	Description
►Change SMBIOS Event Log Settings	This sub-menu allows you to change the SMBIOS Event Log configuration settings.
SMBIOS Event Log	Change this setting to enable or disable all features of the SMBIOS Event Logging during system boot. The options are <b>Enabled</b> and <b>Disabled</b> .
Runtime Error Logging Support	This setting <b>Enables</b> or Disables Runtime Error Logging Support.
Memory Corrected Error Enabling	This setting <b>Enables</b> or Disables Corrected Memory Error Logging.
PCI-Ex Error Enable	This setting Enables or <b>Disables</b> PCI-Ex Error Logging.
Memory Corr. Error Threshold	Use this setting to set the Corrected Memory Error Logging Threshold using the keyboard's "+" or "-" keys. Default is <b>10</b> .
Erase Event Log	If No is selected, data stored in the event log will not be erased. Select Yes, Next Reset, data in the event log will be erased upon next system reboot. Select Yes, Every Reset, data in the event log will be erased upon every system reboot. The options are <b>No</b> , Yes, Next reset, and Yes, Every reset.
When Log is Full	Select Erase Immediately for all messages to be automatically erased from the event log when the event log memory is full. The options are <b>Do Nothing</b> and Erase Immediately.
Log System Boot Event	This option toggles the System Boot Event logging to enabled or disabled. The options are <b>Disabled</b> and Enabled.
MECI	The Multiple Event Count Increment (MECI) counter counts the number of occurrences that a duplicate event must happen before the MECI counter is incremented. This is a numeric value. The default value is <b>1</b> .
METW	The Multiple Event Time Window (METW) defines number of minutes must pass between duplicate log events before MECI is incremented. This is in minutes, from 0 to 99. The default value is <b>60</b> .
►View SMBIOS Event Log	This section displays the contents of the SMBIOS Event Log. It provides a date, time, error code and severity with a brief description of each event.

## 6-7 IPMI Setup

Choose **IPMI Setup** from the BIOS Setup main menu with the arrow keys to bring up the IPMI SETUP menu. IPMI setup options are displayed by highlighting the setting using the arrow keys and pressing <ENTER>. All IPMI Setup BIOS settings are described in [Table 6-15](#) below.

**Table 6-15. IPMI Menu**

Menu Option	Description
IPMI Information	IPMI Firmware Revision and IPMI Status information are statically displayed at the top of this menu.
► System Event Log	Selecting this sub-menu displays settings for changing the SEL Event Log configuration. Note: all values changed here do not take effect until the system is restarted.
SEL Components	Change this setting to <b>Enable</b> or Disable all features of the System Event Logging during boot-up.
Erase SEL	Use this setting for erasing the SEL. Options are <b>No</b> , Yes On Next Reset and Yes On Every Reset.
When SEL is Full	Use this setting to choose options for reactions to a full SEL. Options include <b>Do Nothing</b> and Erase Immediately.
Log EFI Status Codes	Use this setting to <b>Enable</b> or Disable logging of EFI status codes, log only error codes or only progress codes
► BMC Network Configuration	Use this sub-menu to configure BMC network parameters.
BMC Network Configuration Information	The sub-menu contains static display information for the Station IP Address, Subnet Mask, Station MAC Address and Gateway IP Address.
Update IPMI LAN Configuration	Specify Yes or <b>No</b> for the BIOS to use this setting for IPMI in the next boot-up.
Configuration Address Source	This setting allows you to configure LAN channel parameters Statically or Dynamically (by BIOS or BMC). Unspecified option will not modify any BMC network parameters during the BIOS phase. Options are <b>DHCP</b> (dynamic) or Static.

## 6-8 Security

Choose **Security** from the BIOS Setup main menu with the arrow keys to bring up the SECURITY SETUP menu. Security setting options are displayed by highlighting the setting using the arrow keys and pressing <ENTER>. All Security BIOS settings are described in [Table 6-16](#) below.

**Table 6-16. Security Menu Options**

Menu Option	Description
Administrator Password	This allows you to create an administrator password for the system.
User Password	This allows you to create user password for the system.

## 6-9 Boot

Choose **Boot** from the 64 MB SPI Flash EEPROM with AMI® BIOS BIOS Setup Utility main menu with the arrow keys to bring up the BOOT SETUP menu. Security setting options are displayed by highlighting the setting using the arrow keys and pressing <ENTER>. All Security BIOS settings are described in [Table 6-17](#) below.

**Table 6-17. Boot Setup Menu Options**

Menu Option	Description
Boot Priority Option 1 ~ 15	This feature allows you to specify the sequence of priority for the boot device (such as hard disk drives, USB devices, CD-ROM drives, Network drives and so on). The menu options are for 1st Boot Device, 2nd Boot Device and 3rd Boot device. Each numbered boot device can be set to a specific device installed in your system or to Disabled. <b>NOTE:</b> A device enclosed in parenthesis has been disabled in the corresponding type menu.
▶Delete Boot Option	This sub-menu allows you to remove an EFI boot option form the boot order.
▶Delete Driver Option	This sub-menu allows you to remove an EFI driver option form the boot order.
▶Network Device BBS Priorities	This sub-menu allows you to set the order of the legacy devices in this group for setting the boot order.
▶UEFI Application Boot Priorities	This sub-menu specifies the boot device priority sequence from the available UEFI application.

## 6-10 Save & Exit

Choose **SAVE & EXIT** from the 64 MB SPI Flash EEPROM with AMI® BIOS BIOS Setup Utility main menu with the arrow keys to display the **SAVE & EXIT SETUP** menu. All Exit BIOS settings are described in [Table 6-18](#) below.

**Table 6-18. Exit Menu Options**

Menu Option	Description
Discard Changes and Exit	Highlight this item and hit <ENTER> to exit the BIOS Setup utility without saving any changes you may have made. Any changes you have made to the BIOS Setup will not take effect upon system bootup.
Save Changes and Reset	Highlight this item and hit <ENTER> to save any changes you made and to exit the BIOS Setup utility. The system will reboot and implement the changes you have made to the BIOS Setup.
Save Changes	Highlight this item and hit <ENTER> to save changes done so far to any of the setup options.
Discard Changes	Highlight this item and hit <ENTER> to discard (cancel) any changes you made. You will remain in the Setup utility.
Restore Optimized Defaults	Highlight this item and hit <ENTER> to load the default settings for all items in the BIOS Setup. These are the safest settings to use and are designed for maximum system performance, but may not work best for all computer applications.
Save as Users Defaults	Highlight this item and hit <ENTER> to save changes done so far as user defaults.
Restore User Defaults	Highlight this item and hit <ENTER> to restore the user defaults to all the setup options.
Boot Override	For each boot device you have the option of saving the configuration for it and exiting.

## Notes

---

---

# Appendix A

## BIOS POST Codes

### A-1 BIOS POST Messages

During the Power-On Self-Test (POST), the BIOS will check for problems. If a problem is found, the BIOS will activate an alarm or display a message. The following is a list of such BIOS messages.

**Table A-1. BIOS POST Messages**

BIOS Message	Description
Failure Fixed Disk	Fixed disk is not working or not configured properly. Check to see if fixed disk is attached properly. Run Setup. Find out if the fixed-disk type is correctly identified.
Stuck key	Stuck key on keyboard.
Keyboard error	Keyboard not working.
Keyboard Controller Failed	Keyboard controller failed test. May require replacing keyboard controller.
Keyboard locked - Unlock key switch	Unlock the system to proceed.
Monitor type does not match CMOS - Run SETUP	Monitor type not correctly identified in Setup
Shadow Ram Failed at offset: nnnn	Shadow RAM failed at offset <b>nnnn</b> of the 64k block at which the error was detected.
System RAM Failed at offset: nnnn	System RAM failed at offset <b>nnnn</b> of in the 64k block at which the error was detected.
Extended RAM Failed at offset: nnnn	Extended memory not working or not configured properly at offset <b>nnnn</b> .
System battery is dead - Replace and run SETUP	The CMOS clock battery indicator shows the battery is dead. Replace the battery and run Setup to reconfigure the system.
System CMOS checksum bad - Default configuration used	System CMOS has been corrupted or modified incorrectly, perhaps by an application program that changes data stored in CMOS. The BIOS installed Default Setup Values. If you do not want these values, enter Setup and enter your own values. If the error persists, check the system battery or contact your dealer.
System timer error	The timer test failed. Requires repair of system board.
Real time clock error	Real-Time Clock fails BIOS hardware test. May require board repair.
Check date and time settings	BIOS found date or time out of range and reset the Real-Time Clock. May require setting legal date (1991-2099).

Table A-1. BIOS POST Messages (Continued)

BIOS Message	Description
Previous boot incomplete - Default configuration used	Previous POST did not complete successfully. POST loads default values and offers to run Setup. If the failure was caused by incorrect values and they are not corrected, the next boot will likely fail. On systems with control of <b>wait states</b> , improper Setup settings can also terminate POST and cause this error on the next boot. Run Setup and verify that the waitstate configuration is correct. This error is cleared the next time the system is booted.
Memory Size found by POST differed from CMOS	Memory size found by POST differed from CMOS.
Diskette drive A error Diskette drive B error	Drive A: or B: is present but fails the BIOS POST diskette tests. Check to see that the drive is defined with the proper diskette type in Setup and that the diskette drive is attached correctly.
Incorrect Drive A type - run SETUP	Type of floppy drive A: not correctly identified in Setup.
Incorrect Drive B type - run SETUP	Type of floppy drive B: not correctly identified in Setup.
System cache error - Cache disabled	RAM cache failed and BIOS disabled the cache. On older boards, check the cache jumpers. You may have to replace the cache. See your dealer. A disabled cache slows system performance considerably.
CPU ID:	CPU socket number for Multi-Processor error.
EISA CMOS not writeable	ServerBIOS2 test error: Cannot write to EISA CMOS.
DMA Test Failed	ServerBIOS2 test error: Cannot write to extended <b>DMA</b> (Direct Memory Access) registers.
Software NMI Failed	ServerBIOS2 test error: Cannot generate software NMI (Non-Maskable Interrupt).
Fail-Safe Timer NMI Failed	ServerBIOS2 test error: Fail-Safe Timer takes too long.
device Address Conflict	Address conflict for specified <b>device</b> .
Allocation Error for: device	Run ISA or EISA Configuration Utility to resolve resource conflict for the specified <b>device</b> .
CD ROM Drive	CD ROM Drive identified.
Entering SETUP...	Starting Setup program
Failing Bits: nnnn	The hex number <b>nnnn</b> is a map of the bits at the RAM address which failed the memory test. Each 1 (one) in the map indicates a failed bit. See errors 230, 231, or 232 above for offset address of the failure in System, Extended, or Shadow memory.
Fixed Disk n	Fixed disk <b>n</b> (0-3) identified.
Invalid System Configuration Data	Problem with NVRAM (CMOS) data.
I/O device IRQ conflict	I/O device IRQ conflict error.
PS/2 Mouse Boot Summary Screen:	PS/2 Mouse installed.

Table A-1. BIOS POST Messages (Continued)

BIOS Message	Description
nxxx kB Extended RAM Passed	Where <b>nxxx</b> is the amount of RAM in kilobytes successfully tested.
nxxx Cache SRAM Passed	Where <b>nxxx</b> is the amount of system cache in kilobytes successfully tested.
nxxx kB Shadow RAM Passed	Where <b>nxxx</b> is the amount of shadow RAM in kilobytes successfully tested.
nxxx kB System RAM Passed	Where <b>nxxx</b> is the amount of system RAM in kilobytes successfully tested.
One or more I2O Block Storage Devices were excluded from the Setup Boot Menu	There was not enough room in the IPL table to display all installed I2O block-storage devices.
Operating system not found	Operating system cannot be located on either drive A: or drive C:. Enter Setup and see if fixed disk and drive A: are properly identified.
Parity Check 1 nxxx	Parity error found in the system bus. BIOS attempts to locate the address and display it on the screen. If it cannot locate the address, it displays <b>????</b> . Parity is a method for checking errors in binary data. A parity error indicates that some data has been corrupted.
Parity Check 2 nxxx	Parity error found in the I/O bus. BIOS attempts to locate the address and display it on the screen. If it cannot locate the address, it displays <b>????</b> .
Press <F1> to resume, <F2> to Setup, <F3> for previous	Displayed after any recoverable error message. Press <F1> to start the boot process or <F2> to enter Setup and change the settings. Press <F3> to display the previous screen (usually an initialization error of an <b>Option ROM</b> , i.e., an add-on card). Write down and follow the information shown on the screen.
Press <F2> to enter Setup	Optional message displayed during POST. Can be turned off in Setup.
PS/2 Mouse:	PS/2 mouse identified.
Run the I2O Configuration Utility	One or more unclaimed block storage devices have the Configuration Request bit set in the LCT. Run an I2O Configuration Utility (e.g. the SAC utility).
System BIOS shadowed	System BIOS copied to shadow RAM.
UMB upper limit segment address: nxxx	Displays the address <b>nxxx</b> of the upper limit of <b>Upper Memory Blocks</b> , indicating released segments of the BIOS which can be reclaimed by a virtual memory manager.
Video BIOS shadowed	Video BIOS successfully copied to shadow RAM.

## A-2 BIOS POST Codes

This section lists the POST (Power-On Self-Test) codes for the 64 MB SPI Flash EEPROM with AMI® BIOS BIOS. POST codes are divided into two categories: recoverable and terminal.

## Recoverable POST Errors

When a recoverable type of error occurs during POST, the BIOS will display an POST code that describes the problem. BIOS may also issue one of the following beep codes:

- **One long and two short beeps** – video configuration error
- **One repetitive long beep** – no memory detected

## Terminal POST Errors

If a terminal type of error occurs, BIOS will shut down the system. Before doing so, BIOS will write the error to *port 80h*, attempt to initialize video and write the error in the top left corner of the screen.

The following is a list of codes that may be written to *port 80h*.

**Table A-2. Terminal POST Errors**

Post Code	Description
02h	Verify Real Mode
03h	Disable Non-Maskable Interrupt (NMI)
04h	Get CPU type
06h	Initialize system hardware
07h	Disable shadow and execute code from the ROM.
08h	Initialize chipset with initial POST values
09h	Set IN POST flag
0Ah	Initialize CPU registers
0Bh	Enable CPU cache
0Ch	Initialize caches to initial POST values
0Eh	Initialize I/O component
0Fh	Initialize the local bus IDE
10h	Initialize Power Management
11h	Load alternate registers with initial POST values
12h	Restore CPU control word during warm boot
13h	Initialize PCI Bus Mastering devices
14h	Initialize keyboard controller
16h	1-2-2-3 BIOS ROM checksum
17h	Initialize cache before memory Auto size
18h	8254 timer initialization
1Ah	8237 DMA controller initialization
1Ch	Reset Programmable Interrupt Controller
20h	1-3-1-1 Test DRAM refresh

Table A-2. Terminal POST Errors (Continued)

Post Code	Description
22h	1-3-1-3 Test 8742 Keyboard Controller
28h	Auto size DRAM
29h	Initialize POST Memory Manager
2Ah	Clear 512 kB base RAM
2Ch	1-3-4-1 RAM failure on address line <b>xxxx*</b>
2Eh	1-3-4-3 RAM failure on data bits <b>xxxx*</b> of low byte of memory bus
2Fh	Enable cache before system BIOS shadow
32h	Test CPU bus-clock frequency
33h	Initialize Phoenix Dispatch Manager
36h	Warm start shut down
38h	Shadow system BIOS ROM
3Ah	Auto size cache
3Ch	Advanced configuration of chipset registers
3Dh	Load alternate registers with CMOS values
41h	Initialize extended memory for RomPilot
42h	Initialize interrupt vectors
45h	POST device initialization
46h	2-1-2-3 Check ROM copyright notice
47h	Initialize I20 support
48h	Check video configuration against CMOS
49h	Initialize PCI bus and devices
4Ah	Initialize all video adapters in system
4Bh	QuietBoot start (optional)
4Ch	Shadow video BIOS ROM
4Eh	Display BIOS copyright notice
4Fh	Initialize MultiBoot
50h	Display CPU type and speed
51h	Initialize EISA board
52h	Test keyboard
54h	Set key click if enabled
55h	Enable USB devices
58h	2-2-3-1 Test for unexpected interrupts
59h	Initialize POST display service
5Ah	Display prompt "Press F2 to enter SETUP"
5Bh	Disable CPU cache

Table A-2. Terminal POST Errors (Continued)

Post Code	Description
5Ch	Test RAM between 512 and 640 kB
60h	Test extended memory
62h	Test extended memory address lines
64h	Jump to UserPatch1
66h	Configure advanced cache registers
67h	Initialize Multi Processor APIC
68h	Enable external and CPU caches
69h	Setup System Management Mode (SMM) area
6Ah	Display external L2 cache size
6Bh	Load custom defaults (optional)
6Ch	Display shadow-area message
6Eh	Display possible high address for UMB recovery
70h	Display error messages
72h	Check for configuration errors
76h	Check for keyboard errors
7Ch	Set up hardware interrupt vectors
7Dh	Initialize Intelligent System Monitoring
7Eh	Initialize coprocessor if present
80h	Disable onboard Super I/O ports and IRQs
81h	Late POST device initialization
82h	Detect and install external RS232 ports
83h	Configure non-MCD IDE controllers
84h	Detect and install external parallel ports
85h	Initialize PC-compatible PnP ISA devices
86h	Re-initialize onboard I/O ports.
87h	Configure Serverboard Configurable Devices (optional)
88h	Initialize BIOS Data Area
89h	Enable Non-Maskable Interrupts (NMIs)
8Ah	Initialize Extended BIOS Data Area
8Bh	Test and initialize PS/2 mouse
8Ch	Initialize floppy controller
8Fh	Determine number of ATA drives (optional)
90h	Initialize hard-disk controllers
91h	Initialize local-bus hard-disk controllers
92h	Jump to UserPatch2

Table A-2. Terminal POST Errors (Continued)

Post Code	Description
93h	Build MPTABLE for multi-processor boards
95h	Install CD ROM for boot
96h	Clear huge ES segment register
98h	1-2 Search for option ROMs. One long, two short beeps on check-sum failure
99h	Check for SMART Drive (optional)
9Ah	Shadow option ROMs
9Ch	Set up Power Management
9Dh	Initialize security engine (optional)
9Eh	Enable hardware interrupts
9Fh	Determine number of ATA and SCSI drives
A0h	Set time of day
A2h	Check key lock
A4h	Initialize typematic rate
A8h	Erase F2 prompt
AAh	Scan for F2 key stroke
ACh	Enter SETUP
A Eh	Clear Boot flag
B0h	Check for errors
B1h	Inform RomPilot about the end of POST.
B2h	POST done - prepare to boot operating system
B4h	1 One short beep before boot
B5h	Terminate QuietBoot (optional)
B6h	Check password (optional)
B7h	Initialize ACPI BIOS
B9h	Prepare Boot
BAh	Initialize SMBIOS
BBh	Initialize PnP Option ROMs
BCh	Clear parity checkers
BDh	Display MultiBoot menu
BEh	Clear screen (optional)
BFh	Check virus and backup reminders
C0h	Try to boot with INT 19
C1h	Initialize POST Error Manager (PEM)
C2h	Initialize error logging
C3h	Initialize error display function

**Table A-2. Terminal POST Errors (Continued)**

Post Code	Description
C4h	Initialize system error handler
C5h	PnPnd dual CMOS (optional)
C6h	Initialize note dock (optional)
C7h	Initialize note dock late
C8h	Force check (optional)
C9h	Extended checksum (optional)
CAh	Redirect Int 15h to enable remote keyboard
CBh	Redirect Int 13h to Memory Technologies Devices such as ROM, RAM, PCMCIA, and serial disk
CCh	Redirect Int 10h to enable remote serial video
CDh	Re-map I/O and memory for PCMCIA
CEh	Initialize digitizer and display message
D2h	Unknown interrupt

The following are for the boot block in Flash ROM:

**Table A-3. Boot Block Flash ROM Terminal POST Errors**

Post Code	Description
E0h	Initialize the chipset
E1h	Initialize the bridge
E2h	Initialize the CPU
E3h	Initialize system timer
E4h	Initialize system I/O
E5h	Check force recovery boot
E6h	Checksum BIOS ROM
E7h	Go to BIOS
E8h	Set Huge Segment
E9h	Initialize Multi Processor
EAh	Initialize OEM special code
EBh	Initialize PIC and DMA
ECh	Initialize Memory type
EDh	Initialize Memory size
EEh	Shadow Boot Block
EFh	System memory test
F0h	Initialize interrupt vectors
F1h	Initialize Run Time Clock

**Table A-3. Boot Block Flash ROM Terminal POST Errors (Continued)**

Post Code	Description
F2h	Initialize video
F3h	Initialize System Management Manager
F4h	Output one beep
F5h	Clear Huge Segment
F6h	Boot to Mini DOS
F7h	Boot to Full DOS

If the BIOS detects error 2C, 2E, or 30 (base 512K RAM error), it displays an additional word-bitmap (**xxxx**) indicating the address line or bits that failed. For example, "2C 0002" means address line 1 (bit one set) has failed. "2E 1020" means data bits 12 and 5 (bits 12 and 5 set) have failed in the lower 16 bits. The BIOS also sends the bitmap to the port-80 LED display. It first displays the checkpoint code, followed by a delay, the high-order byte, another delay, and then the low order byte of the error. It repeats this sequence continuously.

## Notes

---

---

# Disclaimer

The products sold by Supermicro are not intended for and will not be used in life support systems, medical equipment, nuclear facilities or systems, aircraft, aircraft devices, aircraft/emergency communication devices or other critical systems whose failure to perform be reasonably expected to result in significant injury or loss of life or catastrophic property damage. Accordingly, Supermicro disclaims any and all liability, and should buyer use or sell such products for use in such ultra-hazardous applications, it does so entirely at its own risk. Furthermore, buyer agrees to fully indemnify, defend and hold Supermicro harmless for and against any and all claims, demands, actions, litigation, and proceedings of any kind arising out of or related to such ultra-hazardous use or sale.

