

SUPERMICRO[®]

SBA-7121M-T1 Blade Module

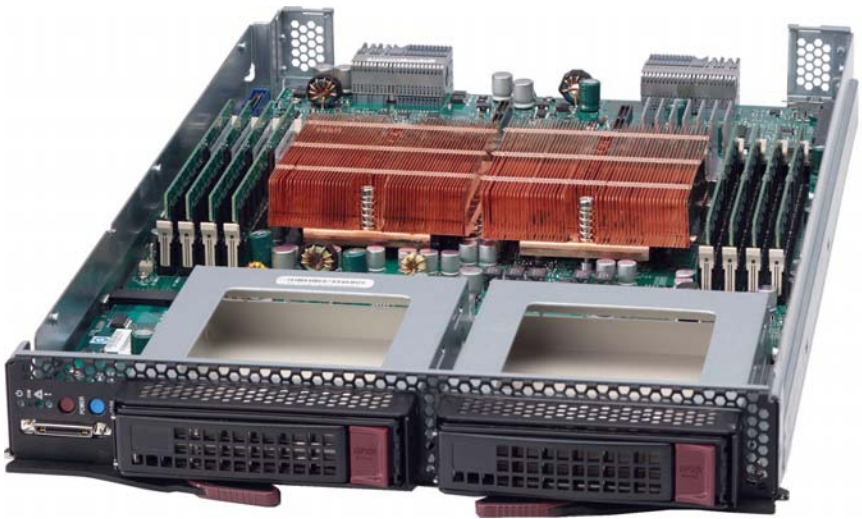

User's Manual

Revision 1.0c

The information in this User's Manual has been carefully reviewed and is believed to be accurate. The vendor assumes no responsibility for any inaccuracies that may be contained in this document, makes no commitment to update or to keep current the information in this manual, or to notify any person or organization of the updates. **Please Note: For the most up-to-date version of this manual, please see our web site at www.supermicro.com.**

Super Micro Computer, Inc. ("Supermicro") reserves the right to make changes to the product described in this manual at any time and without notice. This product, including software and documentation, is the property of Supermicro and/or its licensors, and is supplied only under a license. Any use or reproduction of this product is not allowed, except as expressly permitted by the terms of said license.

IN NO EVENT WILL SUPERMICRO BE LIABLE FOR DIRECT, INDIRECT, SPECIAL, INCIDENTAL, SPECULATIVE OR CONSEQUENTIAL DAMAGES ARISING FROM THE USE OR INABILITY TO USE THIS PRODUCT OR DOCUMENTATION, EVEN IF ADVISED OF THE POSSIBILITY OF SUCH DAMAGES. IN PARTICULAR, SUPERMICRO SHALL NOT HAVE LIABILITY FOR ANY HARDWARE, SOFTWARE, OR DATA STORED OR USED WITH THE PRODUCT, INCLUDING THE COSTS OF REPAIRING, REPLACING, INTEGRATING, INSTALLING OR RECOVERING SUCH HARDWARE, SOFTWARE, OR DATA.

Any disputes arising between manufacturer and customer shall be governed by the laws of Santa Clara County in the State of California, USA. The State of California, County of Santa Clara shall be the exclusive venue for the resolution of any such disputes. Super Micro's total liability for all claims will not exceed the price paid for the hardware product.

FCC Statement: This equipment has been tested and found to comply with the limits for a Class A digital device pursuant to Part 15 of the FCC Rules. These limits are designed to provide reasonable protection against harmful interference when the equipment is operated in a commercial environment. This equipment generates, uses, and can radiate radio frequency energy and, if not installed and used in accordance with the manufacturer's instruction manual, may cause harmful interference with radio communications. Operation of this equipment in a residential area is likely to cause harmful interference, in which case you will be required to correct the interference at your own expense.

California Best Management Practices Regulations for Perchlorate Materials: This Perchlorate warning applies only to products containing CR (Manganese Dioxide) Lithium coin cells. Perchlorate Material-special handling may apply. See www.dtsc.ca.gov/hazardouswaste/perchlorate for further details.



WARNING: HANDLING OF LEAD SOLDER MATERIALS USED IN THIS PRODUCT MAY EXPOSE YOU TO LEAD, A CHEMICAL KNOWN TO THE STATE OF CALIFORNIA TO CAUSE BIRTH DEFECTS AND OTHER REPRODUCTIVE HARM.

Manual Revision 1.0c

Release Date: May 18, 2011

Unless you request and receive written permission from Super Micro Computer, Inc., you may not copy any part of this document.

Information in this document is subject to change without notice. Other products and companies referred to herein are trademarks or registered trademarks of their respective companies or mark holders.

Copyright © 2011 by Super Micro Computer, Inc.
All rights reserved.

Printed in the United States of America

Preface

About this Manual

This manual is written for professional system integrators, Information Technology professionals, service personnel and technicians. It provides information for the installation and use of Supermicro's SBA-7121M-T1 Blade Module. Installation and maintenance should be performed by experienced professionals only.

Manual Organization

Chapter 1: Introduction

The first chapter provides a checklist of the main components included with the SBA-7121M-T1 Blade Module and describes its main features.

Chapter 2: System Safety

You should familiarize yourself with this chapter for a general overview of safety precautions that should be followed when installing and servicing the SBA-7121M-T1 Blade Module.

Chapter 3: Setup and Installation

Refer to this chapter for details on installing the SBA-7121M-T1 Blade Module into the SuperBladeSuperBlade chassis. Other sections cover the installation and placement of memory modules and the installation of hard disk drives into the blade module.

Chapter 4: Blade Module Features

This chapter covers features and component information about the SBA-7121M-T1 Blade Module. Included here are descriptions and information for mainboard components, connectors, LEDs and other features of the blade module.

Chapter 5: RAID Setup Procedure

RAID setup and operations for the SBA-7121M-T1 Blade Module are covered in this chapter.

Chapter 6: BIOS

BIOS setup is covered in this chapter for the SBA-7121M-T1 Blade Module.

Appendix A: BIOS POST Codes

BIOS POST Codes for the SBA-7121M-T1 Blade Module are explained in this appendix.

Notes

Table of Contents

Chapter 1 Introduction	1-1
1-1 Overview.....	1-1
1-2 Product Checklist of Typical Components.....	1-1
1-3 Blade Module Features.....	1-2
Processors.....	1-2
Memory.....	1-2
Storage.....	1-3
Density.....	1-3
1-4 Contacting Supermicro.....	1-4
Chapter 2 System Safety	2-1
2-1 Electrical Safety Precautions.....	2-1
2-2 General Safety Precautions.....	2-2
2-3 Electrostatic Discharge Precautions.....	2-2
2-4 Operating Precautions.....	2-2
Chapter 3 Setup and Installation	3-1
3-1 Overview.....	3-1
3-2 Installing Blade Modules.....	3-1
Powering Up a Blade Unit.....	3-1
Powering Down a Blade Unit.....	3-1
Removing a Blade Unit from the Enclosure.....	3-1
Removing/Replacing the Blade Cover.....	3-2
Installing a Blade Unit into the Enclosure.....	3-2
3-3 Processor Installation.....	3-4
3-4 Onboard Battery Installation.....	3-5
3-5 Memory Installation.....	3-6
Populating Memory Slots.....	3-6
DIMM Installation.....	3-7
USB Memory Stick Installation.....	3-8
3-6 Hard Disk Drive Installation.....	3-8
3-7 Installing the Operating System.....	3-9
Installing with an External USB CD-ROM Drive.....	3-10
Installing via PXE Boot.....	3-10
Installing via Virtual Media (Drive Redirection).....	3-10

3-8 Management Software	3-10
3-9 Configuring and Setting up RAID	3-11
Chapter 4 Blade Module Features	4-1
4-1 Control Panel	4-2
Power Button	4-3
KVM Button.....	4-3
LED Indicators	4-3
KVM Connector.....	4-3
4-2 Mainboard.....	4-4
Jumpers	4-5
CMOS Clear.....	4-5
4-3 Blade Unit Components	4-6
Memory Support	4-7
Hard Disk Drives	4-7
Chapter 5 RAID Setup Procedure	5-1
5-1 Preparing for Setup.....	5-1
5-2 Changing BIOS Settings for RAID Configuration.....	5-1
5-3 Configuring RAID in the Media Shield BIOS Utility.....	5-1
Chapter 6 BIOS	6-1
6-1 Introduction.....	6-1
Running Setup	6-1
6-2 Main BIOS Setup Menu	6-1
System Time/System Date	6-2
6-3 Advanced Settings Menu	6-2
BOOT Features.....	6-3
CPU Configuration	6-4
SATA Configuration.....	6-4
PCI/PnP Configuration.....	6-6
Super IO Configuration	6-7
Chipset Configuration	6-7
NorthBridge Configuration.....	6-7
SouthBridge/MCP55 Configuration	6-9
Event Log Configuration	6-10
PCI Express Configuration.....	6-10
Remote Access Configuration	6-10
System Health Monitor.....	6-11

6-4 Boot Menu	6-11
6-5 Security Menu	6-12
6-6 Exit Menu.....	6-13
Appendix A BIOS POST Codes	A-1
A-1 BIOS POST Messages	A-1
A-2 BIOS POST Codes.....	A-3
Recoverable POST Errors	A-4
Terminal POST Errors.....	A-4

Notes

List of Figures

Figure 1-1. Full Rack of Blade Enclosures and Blade Servers	1-3
Figure 3-1. Inserting a Blade into the Enclosure	3-3
Figure 3-2. Locking the Blade into Position.....	3-3
Figure 3-3. Installing a Processor in a Socket.....	3-5
Figure 3-4. Installing the Onboard Battery	3-5
Figure 3-5. 8-slot DIMM Numbering.....	3-7
Figure 3-6. Installing a DIMM into a Memory Slot.....	3-8
Figure 3-7. Installing a Hard Drive in a Carrier.....	3-9
Figure 4-1. SBA-7121M-T1 Blade Unit Front View	4-1
Figure 4-2. Blade Control Panel.....	4-2
Figure 4-3. BHDME Mainboard.....	4-4
Figure 4-4. NVidia MCP55 Pro Chipset: Block Diagram for SBA-7121M-T1	4-5
Figure 4-5. Exploded View of SBA-7121M-T1 Blade Module	4-6

Notes

List of Tables

Table 1-1. SBA-7121M-T1 Blade Specification Features	1-2
Table 3-1. Populating 8 Memory Slots and 2 CPUs for Interleaved Operation.....	3-7
Table 4-1. SBA-7121M-T1 Blade Unit Features	4-1
Table 4-2. Blade Control Panel.....	4-2
Table 4-3. Blade Module LED Indicators	4-3
Table 4-4. BHQME Mainboard Layout.....	4-5
Table 4-5. Main Components of SBA-7121M-T1 Blade Unit	4-7
Table 6-1. BOOT Features.....	6-3
Table 6-2. CPU Configuration Submenu.....	6-4
Table 6-3. SATA Configuration Submenu.....	6-4
Table 6-4. PCI/PnP Configuration Submenu	6-6
Table 6-5. Super IO Configuration Submenu.....	6-7
Table 6-6. Chipset Configuration Submenu.....	6-7
Table 6-7. NorthBridge Configuration Submenu	6-7
Table 6-8. SouthBridge/MCP55 Configuration Submenu	6-9
Table 6-9. Event Log Configuration Submenu	6-10
Table 6-10. PCI Express Configuration Submenu	6-10
Table 6-11. Remote Access Configuration Submenu.....	6-10
Table 6-12. System Health Monitor Submenu	6-11
Table 6-13. Boot Menu.....	6-11
Table 6-14. Security Menu.....	6-12
Table 6-15. Exit Menu	6-13
Table A-1. BIOS POST Messages.....	A-1
Table A-2. Terminal POST Errors.....	A-4
Table A-3. Boot Block Flash ROM Terminal POST Errors.....	A-8

Notes

Chapter 1

Introduction

1-1 Overview

The SBA-7121M-T1 blade module is a compact self-contained server that connects into a pre-cabled enclosure that provides power, cooling, management and networking functions. One enclosure for the SBA-7121M-T1 blade module can hold ten blade units.

In this manual, “blade system” refers to the entire system (including the enclosure and blades units), “blade” or “blade unit” refers to a single blade module and “blade enclosure” is the chassis that the blades, power supplies and modules are housed in.

Please refer to our web site for information on operating systems that have been certified for use with the SuperBlade (www.supermicro.com/products/superblade/).

1-2 Product Checklist of Typical Components

Your blade module ships with its mainboard already installed in its chassis. Memory, hard disk drives and the CPU must all be installed by the user after shipment. See [Chapter 3: "Setup and Installation" on page 3-1](#) for details on installation of these components.

Aside from the blade module unit itself, the following optional add-on cards may be ordered for your blade module:

- Blade IPMI Add-on Card: AOC-SIMBL
- Mezzanine Cards (with Infiniband Switch): AOC-IBH-XDD, AOC-IBH-XDS or AOC-IBH-002

See the [Supermicro website](#) and the *SuperBlade Network Modules User's Manual* on your SuperBlade system's CD-ROM for more details on these add-on cards.

1-3 Blade Module Features

Table 1-1 lists the main features of the SBA-7121M-T1 blade module. See the proceeding section for components typically included in a blade system and other optional components. Specific details on the SBA-7121M-T1 blade module is found in Chapter 4: "Blade Module Features" on page 4-1.

Table 1-1. SBA-7121M-T1 Blade Specification Features

Mainboard	BHDME (proprietary form factor) Chassis Dimensions (HxWxD): 11.32" x 1.67" x 18.5"
Processors	Supports Dual 1207-pin Socket F processors for up to two Six-Core AMD Opteron™ series processors HT 3.0 Link support. Please refer to our web site for a complete listing of supported processors.
FSB Speed	Hyper Transport: 1000 MHz front side (system) bus speed
Chipset	NVidia MCP55 Pro
Graphics Controller	Onboard ATI ES1000 graphics chip with 16MB of SDRAM
BIOS	8 Mb AMI® Flash ROM
Memory Capacity	Eight 240-pin DIMM sockets supporting up to 64 GB of ECC Registered DDR2-800/667/533 SDRAM DIMMS in two 4-DIMM slot banks.
SATA Controller	NVidia MCP55 Pro on-chip controller for two Serial ATA drives
Hard Drive Bays	Two (2) hot-swap drive bays for 3.5" SATA disk drives

Processors

The SBA-7121M-T1 blade module supports up to dual 771-pin Intel Xeon 2300/2200 series processors.

Refer to the Supermicro web site for a complete listing of supported processors (<http://www.supermicro.com/products/superblade>). Please note that you will need to check the detailed specifications of a particular blade module for a list of the CPUs it supports.

Details on installation of the processor into the SBA-7121M-T1 blade module are found in Chapter 3: "Setup and Installation" on page 3-1.

Memory

The SBA-7121M-T1 blade module has eight 240-pin DIMM sockets that can support up to 64 GB of ECC FBD (Fully Buffered DIMM) DDR2-800/667/533 SDRAM. Memory is interleaved, which requires modules of the same size and speed to be installed in groups (of two or three).

Please refer to the Supermicro web site for a list of supported memory (www.supermicro.com/products/superblade). The detailed specifications for a blade module will contain a link to a list of recommended memory sizes and manufacturers.

Details on installation of memory modules into the SBA-7121M-T1 blade module are found in Chapter 3: "Setup and Installation" on page 3-1.

Storage

The SBA-7121M-T1 blade module can have two 3.5-inch SATA (Serial ATA) hard disk drives in front-mounted easy removable carriers. See [Chapter 3: "Setup and Installation" on page 3-1](#) for storage installation details.

Density

A maximum of ten blade modules may be installed into a single blade enclosure. Each blade enclosure is a 7U form factor, so a standard 42U rack may accommodate up to six enclosures with 60 blade modules, or the equivalent of 60 1U servers. With the inclusion of six CMM modules, twelve Gigabit Ethernet switches and six InfiniBand switches, this would occupy up to 84U space in a conventional 1U server configuration.

[Figure 1-1](#) displays a view of a full rack with six blade enclosures in it, each with ten blades to an enclosure.

Figure 1-1. Full Rack of Blade Enclosures and Blade Servers



1-4 Contacting Supermicro

Headquarters

Address: Super Micro Computer, Inc.
980 Rock Ave.
San Jose, CA 95131 U.S.A.

Tel: +1 (408) 503-8000

Fax: +1 (408) 503-8008

Email: marketing@supermicro.com (General Information)
support@supermicro.com (Technical Support)

Web Site: www.supermicro.com

Europe

Address: Super Micro Computer B.V.
Het Sterrenbeeld 28, 5215 ML
's-Hertogenbosch, The Netherlands

Tel: +31 (0) 73-6400390

Fax: +31 (0) 73-6416525

Email: sales@supermicro.nl (General Information)
support@supermicro.nl (Technical Support)
rma@supermicro.nl (Customer Support)

Asia-Pacific

Address: Super Micro Computer, Inc.
4F, No. 232-1, Liancheng Rd.
Chung-Ho 235, Taipei County
Taiwan, R.O.C.

Tel: +886-(2) 8226-3990

Fax: +886-(2) 8226-3991

Web Site: www.supermicro.com.tw

Technical Support:

Email: support@supermicro.com.tw

Tel: +886-2-8228-1366, ext. 132 or 139

Chapter 2

System Safety

2-1 Electrical Safety Precautions

Basic electrical safety precautions should be followed to protect yourself from harm and the SuperBlade from damage:

- Be aware of how to power on/off the enclosure power supplies and the individual blades as well as the room's emergency power-off switch, disconnection switch or electrical outlet. If an electrical accident occurs, you can then quickly remove power from the system.
- Do not work alone when working with high voltage components.
- Power should always be disconnected from the blade module when removing or installing such system components as the mainboard, memory modules and processors.
- When working around exposed electrical circuits, another person who is familiar with the power-off controls should be nearby to switch off the power if necessary.
- Use only one hand when working with powered-on electrical equipment. This is to avoid making a complete circuit, which will cause electrical shock. Use extreme caution when using metal tools, which can easily damage any electrical components or circuit boards they come into contact with.
- Do not use mats designed to decrease electrostatic discharge as protection from electrical shock. Instead, use rubber mats that have been specifically designed as electrical insulators.
- The power supply power cords must include a grounding plug and must be plugged into grounded electrical outlets. Power input requires 110-240 VAC, depending upon your power supply module.
- Mainboard Battery: This battery must be replaced only with the same or an equivalent type recommended by the manufacturer (CR2032 Lithium 3V battery). Dispose of used batteries according to the manufacturer's instructions.



WARNING: There is a danger of explosion if the onboard battery is installed upside down, which will reverse its polarities.

- Mainboard replaceable soldered-in fuses: Self-resetting PTC (Positive Temperature Coefficient) fuses on the mainboard must be replaced by trained service technicians only. The new fuse must be the same or equivalent as the one replaced. Contact technical support for details and support.

2-2 General Safety Precautions

Follow these rules to ensure general safety:

- Keep the area around the SuperBlade clean and free of clutter.
- Place the blade module cover and any system components that have been removed away from the system or on a table so that they won't accidentally be stepped on.
- While working on the system, do not wear loose clothing such as neckties and unbuttoned shirt sleeves, which can come into contact with electrical circuits or be pulled into a cooling fan.
- Remove any jewelry or metal objects from your body, which are excellent metal conductors that can create short circuits and harm you if they come into contact with printed circuit boards or areas where power is present.
- After accessing the inside of the system, replace the blade module's cover before installing it back into the blade enclosure.

2-3 Electrostatic Discharge Precautions

Electrostatic discharge (ESD) is generated by two objects with different electrical charges coming into contact with each other. An electrical discharge is created to neutralize this difference, which can damage electronic components and printed circuit boards.

The following measures are generally sufficient to neutralize this difference **before** contact is made to protect your equipment from ESD:

- Use a grounded wrist strap designed to prevent static discharge.
- Keep all components and printed circuit boards (PCBs) in their antistatic bags until ready for use.
- Touch a grounded metal object before removing the board from the antistatic bag.
- Do not let components or PCBs come into contact with your clothing, which may retain a charge even if you are wearing a wrist strap.
- Handle a board by its edges only; do not touch its components, peripheral chips, memory modules or contacts.
- When handling chips or modules, avoid touching their pins.
- Put the mainboard and peripherals back into their antistatic bags when not in use.
- For grounding purposes, make sure the blade enclosure provides excellent conductivity between the power supplies, the blade modules and the mainboard.

2-4 Operating Precautions

Care must be taken to assure that the cover of the blade unit is in place when the blade is operating to assure proper cooling. Out of warranty damage to the blade can occur if this practice is not strictly followed.

Any drive carrier without a hard drive installed must remain fully installed in the drive bay when the blade module is operating to ensure proper airflow.

Chapter 3

Setup and Installation

3-1 Overview

This chapter covers the setup and installation of the blade module and its components.

3-2 Installing Blade Modules

Up to ten SBA-7121M-T1 blade modules may be installed into a single blade enclosure (depending upon your enclosure and blad). Blade modules with Windows and Linux operating systems may be mixed together in the same blade enclosure.

Powering Up a Blade Unit

Each blade unit may be powered on and off independently from the rest of the blades installed in the same enclosure. A blade unit may be powered up in two ways:

- Press the power button on the blade unit.
- Use IPMIView or the web-browser based management utility to apply power using either a CMM module, or by the use of an installed SIMBL add-on card in the blade module.

Powering Down a Blade Unit

A blade unit may be powered down in either of five ways:

- Press the power button on the blade unit.
- Use IPMIView or the web-browser based management utility to power down (if you have Operator or Admin privileges on the CMM).
- Use IPMItool when connected to the CMM to power down (if you have Operator or Admin privileges on the CMM).
- Use IPMIview or a browser connected to the SIMBL card attached to the blade to power down.
- Use IPMItool to use a Command Line Interface (CLI) to the SIMBL (if you have Operator or Admin privileges).

Removing a Blade Unit from the Enclosure

Although the blade system may continue to run, individual blades should always be powered down before removing them from the enclosure.

Removing a Blade Unit from the Enclosure

1. Power down the blade unit (see "[Powering Down a Blade Unit](#)" above).
2. Squeeze both handles to depress the red sections then pull out both handles completely and use them to pull the blade unit from the enclosure.



NOTE: Blade Modules can be Hot-Plugged from the enclosure.

Removing/Replacing the Blade Cover

The blade cover must be removed to access the mainboard when you need to install or remove processors, memory units, the onboard battery and so on.

Removing/Replacing the Blade Cover

1. Remove the blade unit from the enclosure (see "[Removing a Blade Unit from the Enclosure](#)" above).
2. Depress the two buttons on the cover while pushing the cover toward the rear of the blade unit. When it stops, lift the cover off the blade unit.
3. To replace the cover, fit the six grooves in the cover into the studs in the sides of the blade, then slide the cover toward the front of the blade to lock it into place.

Installing a Blade Unit into the Enclosure

Make sure the cover of the blade unit has been replaced first before installing a blade unit in the enclosure.

Installing a Blade Unit into the Enclosure

1. Slowly push the blade unit into its bay with the handles fully pulled out (see [Figure 3-1](#)).
2. When the blade stops, push the handles back in to their locked position, making sure the notches in both handles catch the lip of the enclosure (see [Figure 3-2](#)).



NOTE: Blade Modules can be Hot-Plugged into the enclosure.



WARNING: Use extreme caution when inserting a blade module into the enclosure. If the blade's power connector becomes damaged, it can damage pins on other blade bays that it is inserted into.

Figure 3-1. Inserting a Blade into the Enclosure

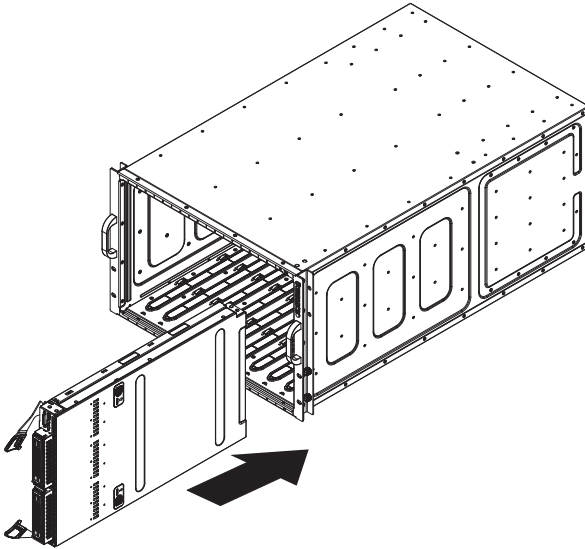
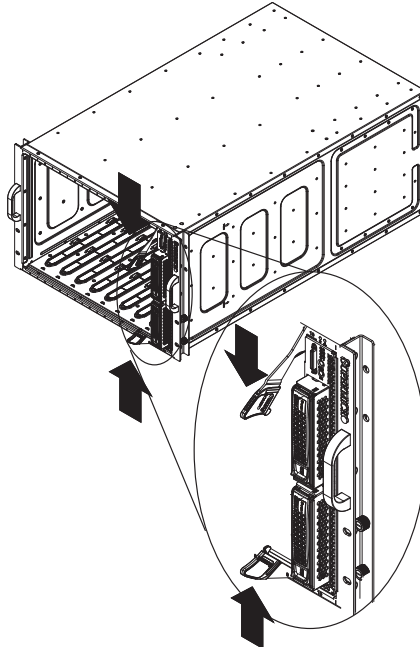

Figure 3-2. Locking the Blade into Position



3-3 Processor Installation

One or two processors may be installed to the mainboard of each blade unit. See [Chapter 1](#) for general information on the features of the blade unit and the [Supermicro web site](#) for further details including processor, memory and operating system support.



WARNING: This action should only be performed by a trained service technician. Allow the processor heatsink to cool before removing it.

Removing a Processor

1. Power down and remove the blade unit from the enclosure (see [Section 3-2: Installing Blade Modules on page 3-1](#) for details).
2. Remove the cover of the blade unit (see "[Removing/Replacing the Blade Cover](#)" on [page 3-2](#)).
3. Loosen the four screws that secure the heatsink to the mainboard.
4. Remove the heatsink by *gently* rotating it back-and-forth sideways with your fingers to release it from the processor. Set the heatsink aside and upside-down so that nothing comes into contact with the thermal grease on its underside.
5. Raise the lever of the processor socket up until the processor is released from the socket, then lift the silver cover plate and remove the processor.



WARNING: This action should only be performed by a trained service technician.

Installing a Processor

1. If present, remove the protective black PnP cap from the processor socket.
2. Raise the lever of the processor socket until it reaches its upper limit.
3. Lift the silver cover plate completely up and out of the way.



NOTE: Be careful not to damage the pins protruding from the CPU socket.

4. Align pin 1 of the processor with pin 1 of the socket (both are marked with a small gold triangle) and gently seat the processor into the socket ([Figure 3-3](#)).
5. Check to make sure the processor is flush to the socket and fully seated.
6. Lower the socket lever until it locks.
7. To install the heatsink, apply thermal grease to the top of the processor. (If reinstalling a heatsink, first clean off the old thermal grease with a clean, lint-free cloth.)

- Place the heatsink on the processor then tighten two diagonal screws until snug, then the other two screws.
- When all four screws are snug, tighten them all to secure the heatsink to the mainboard.



NOTE: Do not overtighten the screws as this may damage the processor or the heatsink.

- Replace the cover on the blade unit and finish by installing the unit back into the blade enclosure.

Figure 3-3. Installing a Processor in a Socket

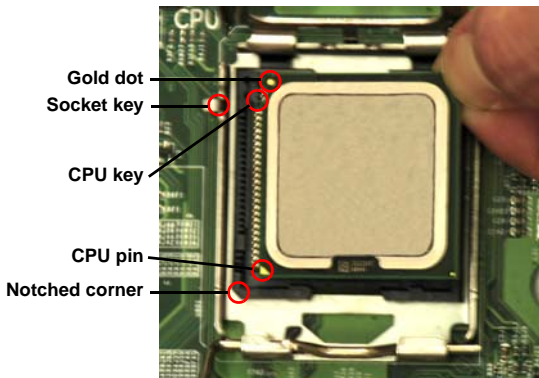

3-4 Onboard Battery Installation

A battery is included on the mainboard to supply certain volatile memory components with power when power has been removed from the blade module. If this battery dies, it must be replaced with an equivalent CR2032 Lithium 3V battery. Dispose of used batteries according to the manufacturer's instructions. See [Figure 3-4](#) for a diagram of installing a new onboard battery.



WARNING: There is a danger of explosion if the onboard battery is installed upside down, which reverses its polarities.

Figure 3-4. Installing the Onboard Battery

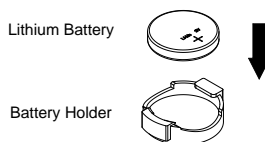

3-5 Memory Installation

The mainboard of each blade unit must be populated with DIMMs (Dual In-line Memory Modules) to provide system memory. **The DIMMs should all be of the same size and speed and from the same manufacturer due to compatibility issues.**

See below for details on supported memory and our web site (www.supermicro.com/products/superblade) for recommended memory.

Populating Memory Slots

The mainboard has eight to sixteen memory slots, depending upon the blade model. Both interleaved and non-interleaved memory are supported, so you may populate any number of DIMM slots. Maximum memory is 64 GB ECC Registered DDR2-800/667/533 SDRAM for dual-CPU configurations.

Populating two slots at a time with memory modules of the same size and of the same type will result in dual-channel, interleaved memory, which is faster than single-channel, non-interleaved memory. In this case it is better to spread pairs of DIMMs across all memory banks with a CPU installed than to fill up one CPU memory bank while leaving another empty.

For example, if you were to install eight DIMMs in a quad-CPU configuration, you should install two in the CPU1 DIMM slots (slots 1A and 1B), two in the CPU2 DIMM slots, two in the CPU3 DIMM slots and two in the CPU4 DIMM slots rather than four in any two CPU DIMM slots. If you install four more, install two in the remaining CPU1 DIMM slots and two in the remaining CPU2 DIMM slots, etc. This balances the load over all CPUs to optimize performance. In a dual-CPU configuration, memory can only be installed in the banks associated with CPU#1 and CPU#2.

See [Table 3-1](#) and [Figure 3-5](#) for DIMM slot number information.

For an interleaved configuration, memory modules of the same size and speed must be installed in pairs. You should not mix DIMMs of different sizes and speeds.



NOTE: Each processor has its own built-in memory controller, consequently each CPU has a four-slot memory bank associated with it. Memory installed into a bank with no CPU present cannot be accessed.

Memory modules with a size of 128 MB, 256 MB, 512 MB, 1 GB, 2 GB, 4 GB and 8 GB are supported.



WARNING: It is highly recommended that you remove the power cord from the system before installing or changing any memory modules.

Table 3-1. Populating 8 Memory Slots and 2 CPUs for Interleaved Operation

Number of DIMMS	CPU0				CPU1			
	Channel 0		Channel 1		Channel 0		Channel 1	
	1A	1B	2A	2B	1A	1B	2A	2B
2	X				X			
4	X	X			X	X		
6	X	X	X	X	X	X		
8	X	X	X	X	X	X	X	X

Figure 3-5. 8-slot DIMM Numbering

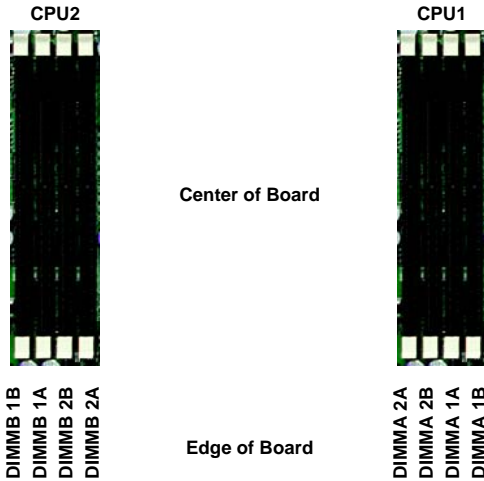

DIMM Installation



WARNING: Exercise extreme care when installing or removing DIMM modules to prevent any possible damage.

Installing Memory Modules

1. Power down the blade module.
2. Remove the blade from the enclosure and the cover from the blade.
3. Remove the air shroud that covers the DIMM slots.

4. Insert each DIMM vertically into its slot, paying attention to the notch along the bottom of the module to prevent inserting the module incorrectly (see [Figure 3-6](#)).
Insert first into the 1A slot(s), then the 1B slot(s), then the 2A slot(s) and 2B slot(s). See support information below.

Figure 3-6. Installing a DIMM into a Memory Slot

To Install: Insert module vertically and press down until it snaps into place. Pay attention to the bottom notch.

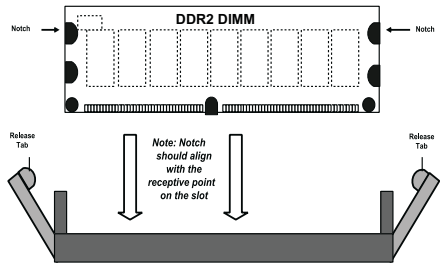

To Remove: Use your thumbs to gently push each release tab outward to free the DIMM from the slot.

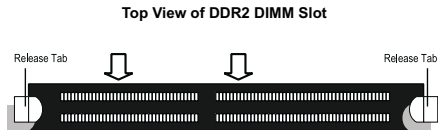

5. Gently press down on the DIMM until it snaps into place in the slot. Repeat for all modules (see [Table 3-1](#) for installing DIMMs into the slots in the correct order).
6. Replace the air shroud and the blade cover and install the blade module back into the enclosure.
7. Power up the blade unit.

USB Memory Stick Installation

All newer blades (at this time the SBX-####A-A# blade only) have a provision for a Type A connector that will allow a USB memory stick to be placed on the blade. This is used to support ESX VMware, a custom BIOS extension (such as ScaleMP), or as a read-only bootable operating system that will allow the system to save power by eliminating mirrored drives for a reliable operating system.

3-6 Hard Disk Drive Installation

Hard disk drives are installed in “carriers” which are hot-swappable and can be removed or replaced without powering down the blade unit they reside in. A blade module needs a hard disk drive with an operating system installed to operate.



WARNING: To maintain proper airflow, both hard drive bays must have drive carriers inserted during operation whether or not a drive is installed in the carrier.

To remove a hard drive carrier, do the following:

Removing a Hard Drive Carrier

1. Locate the colored “Open” button at the bottom of the drive carrier and press it with your thumb. This action releases the drive carrier from the drive bay.
2. Pull the release handle out about 45-degrees, then use it to pull the drive carrier out.

To Install a hard drive, use the following procedure:

Installing a Hard Drive

1. Remove a blank drive carrier from the blade (see removal procedure above).
2. Insert a drive into the carrier with the PCB side facing down and the connector end toward the rear of the carrier.
3. Align the drive in the carrier so that the screw holes of both line up.
4. Secure the drive to the carrier with six screws as shown in [Figure 3-7](#).
5. Insert the drive carrier into its slot keeping the Open button at the bottom. When the carrier reaches the rear of the bay the release handle will retract.
6. Push the handle in until you hear the carrier click into its locked position.

Figure 3-7. Installing a Hard Drive in a Carrier

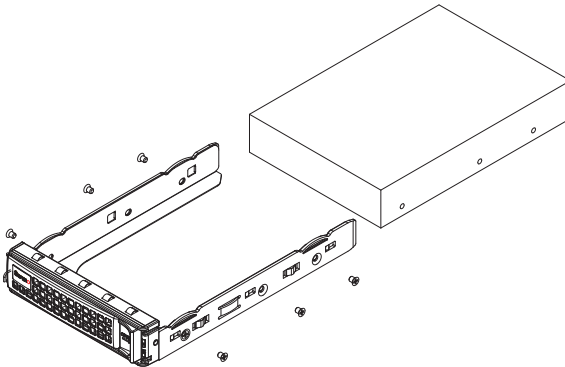

3-7 Installing the Operating System

An operating system (OS) must be installed on each blade module. Blades with Microsoft Windows OS and blades with Linux OS can both occupy and operate within the same blade enclosure. Refer to the SuperMicro web site for a complete list of supported operating systems.

There are several methods of installing an OS to the blade modules.

Installing with an External USB CD-ROM Drive

The most common method of installing the OS is with an external USB CD-ROM drive. Take the following steps to install the OS to a blade module:



WARNING: Installing the OS from an external CD-ROM drive may take several hours to complete.

1. Connect an SUV cable (Serial port/USB port/Video port cable) to the KVM connector on the front of the blade module. You will then need to attach a USB hub to the USB port on this cable to provide multiple USB ports.
2. Connect the external CD-ROM drive, a USB keyboard and a mouse to the USB hub. You will also need to connect a monitor to the video connector on the SUV cable. Turn on the blade module.
3. Insert the CD containing the OS into the CD-ROM drive.
4. Follow the prompts to begin the installation.

Installing via PXE Boot

PXE (Preboot Execution Environment) is used to boot a computer over a network. To install the OS via PXE, the following conditions must be met:

1. The PXE BOOT option in BIOS must be enabled.
2. A PXE server has been configured (this can be another blade in the system).
3. The PXE server must be connected over a network to the blade to be booted.
4. The blade has only non-partitioned/unformatted hard drives installed and no bootable devices attached to it.

Once these conditions are met, make sure the PXE server is running. Then turn on the blade on which you wish to boot and/or install the OS. The BIOS in the blade will look at all bootable devices and finding none will connect to the PXE server to begin the boot/install.

Installing via Virtual Media (Drive Redirection)

You can install the OS via Virtual Media through either the *IPMIview* (Java based client utility), *IPMItool* or the *Web-based Management Utility*. With this method, the OS is installed from an ISO image that resides on another system/blade.

Refer to the manuals on your SuperBlade CD-ROM for further details on the Virtual Media (CD-ROM or Drive Redirection) sections of these two utility programs.

3-8 Management Software

System management may be performed with either of three software packages: *IPMIview*, *IPMItool* or a *Web-based Management Utility*. These are designed to provide

an administrator with a comprehensive set of functions and monitored data to keep tabs on the system and perform management activities.

Refer to the manuals on your SuperBlade CD-ROM for further details on the various functions provided by these management programs.

3-9 Configuring and Setting up RAID

Each blade module that supports two or more hard drives may be used to create a RAID array. The procedures for doing this vary depending upon the blade model chosen for your SuperBlade system.

See [Chapter 5](#) for details on how to configure and set up RAID on your blade module.

Notes

Chapter 4

Blade Module Features

Figure 4-1. SBA-7121M-T1 Blade Unit Front View

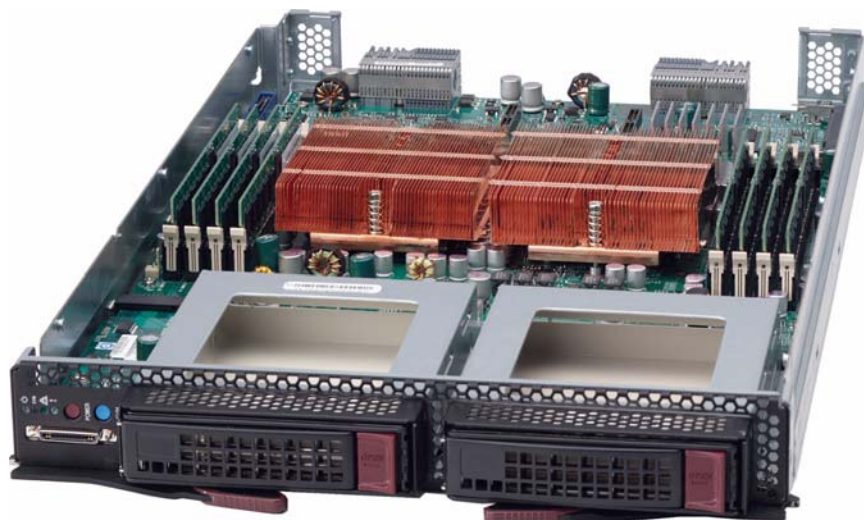

This chapter describes the SBA-7121M-T1 blade unit. Installation and maintenance should be performed by experienced technicians only.

See [Figure 4-1](#) for a front view of the blade unit and [Table 4-1](#) for its features.

Table 4-1. SBA-7121M-T1 Blade Unit Features

Feature	Description
Processors	Supports two AMD Six/Quad/Dual-Core Opteron 2300/2200 series processors
Memory	Supports up to 64 GB of ECC Registered DDR2-800/667/533 SDRAM in eight DIMM slots
Storage	One or two 3.5" hot-plug SATA hard disk drives
Ports	KVM port (1)
Features	Onboard ATI ES1000 graphics chip with 16MB of SDRAM, IPMI 2.0, ATA/100, Plug and Play, APM 1.2, DMI 2.3, PCI 2.2, ACPI 1.0/2.0, SMBIOS 2.3, Real Time Clock, Watch Dog,
Power Consumption	Base Power Draw (~35W) / Power per CPU (50W/80W/120W) / Power per DIMM (typically ~7W)

4-1 Control Panel

Each blade has a similar control panel (Figure 4-2) with power on/off button, a KVM connector, a KVM button and four LEDs on the top front of the unit. The numbers mentioned in Figure 4-2 are described in Table 4-2.

Figure 4-2. Blade Control Panel

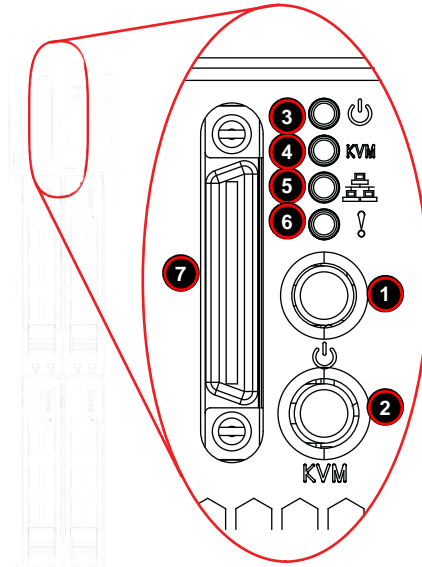

Table 4-2. Blade Control Panel

Item	Function	State	Description
1	Power Button	N/A	Turns blade module on and off
2	KVM Button	N/A	Initiates KVM function
3	Power LED	Green	Indicates power status "On"
		Orange	Indicates power status "Off" (with power cables plugged in)
4	KVM/UID LED	Blue	Indicates KVM being utilized on blade unit
		Flashing Blue	Indicates UID activated on blade module
5	Network/IB LED	Flashing Green	Indicates network activity over LAN
		Flashing Orange	Indicates network activity over InfiniBand module
6	System Fault LED	Red	Indicates a memory error, overheat, VGA error or any error that prevents booting
7	KVM Connector	N/A	Connector for SUV/KVM cable

Power Button

Each blade has its own power button so that individual blade units within the enclosure may be turned on or off independently of the others. Press the power button (#1) to turn on the blade server. The power LED (#3) will turn green. To turn off, press and hold the power button for >4 seconds and the power LED will turn orange.

KVM Button

KVM stands for Keyboard/Video/Mouse. With KVM, a user can control multiple blades with a single keyboard/video/mouse setup. Connect your keyboard, mouse and monitor to the USB and VGA connectors on the CMM module, then push the KVM button on the control panel of the blade module you wish to access.

LED Indicators

Blade module LEDs are described below in [Table 4-3](#).

Table 4-3. Blade Module LED Indicators

LED	State	Description
Power LED	Green	Power On
	Amber	Standby
	Red	Power Failure ^a
KVM/UID LED (Blue)	Steady On	Indicates that KVM has been initialized on this blade module
	Flashing	Serves as a UID indicator (the UID function is activated with a management program)
Network LED (Green)	Flashing	Flashes on and off to indicate traffic (Tx and Rx data) on the LAN connection to this blade module.
System Fault LED (Red)	Steady On	This LED illuminates red when a fatal error occurs. This may be the result of a memory error, a VGA error or any other fatal error that prevents the operating system from booting up.

- a. In the event of a power failure, the N+1 Redundant Power Supply (if included in your system's configuration) automatically turns on and picks up the system load to provide uninterrupted operation. The failed power supply should be replaced with a new one as soon as possible.

KVM Connector

Alternatively, you may connect a KVM cable (CBL-0218L, with a keyboard/video/mouse attached) to the KVM connector (#7) of the blade you wish to access. To switch to another blade, disconnect the cable then reconnect it to the new blade.

See the *Web-based Management Utility User's Manual* on your SuperBlade system CD-ROM for further details on using the KVM function remotely.

4-2 Mainboard

The mainboard of the SBA-7121M-T1 blade unit is a proprietary design, which is based on the NVidia MCP55 Pro chipset. See [Figure 4-4](#) for a block diagram of this chipset, [Figure 4-3](#) for a view of the BHDME Mainboard and [Figure 4-5](#) for an exploded view diagram of the blade unit.

Figure 4-3. BHDME Mainboard

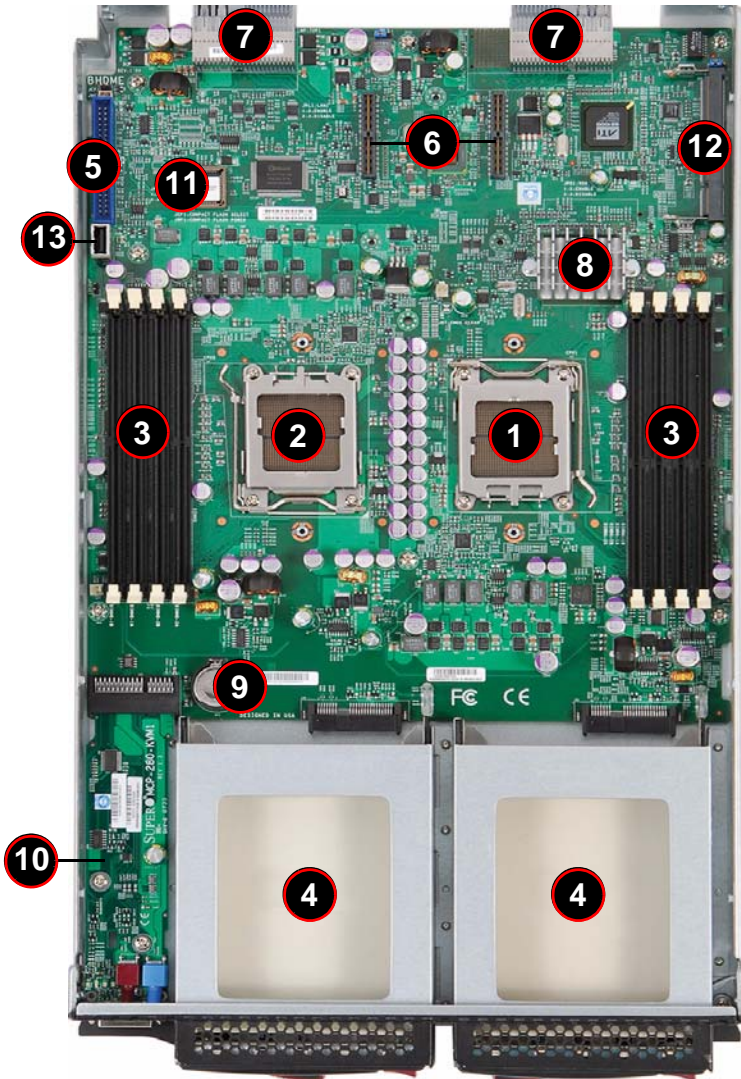
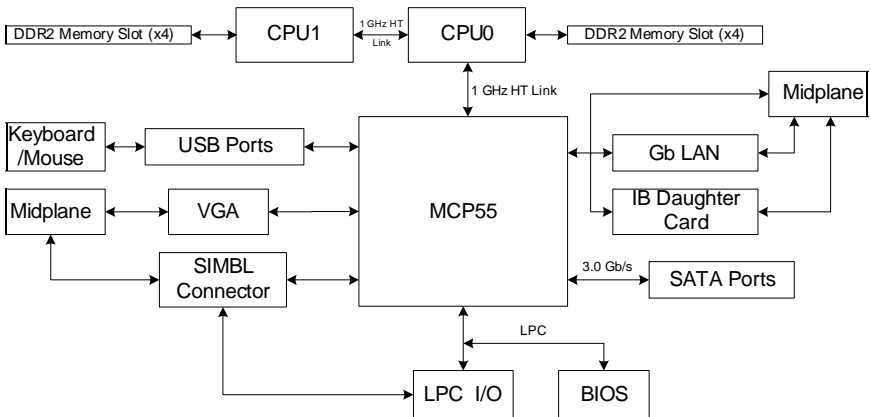

Table 4-4. BQME Mainboard Layout

Item	Description
1	CPU Socket for CPU1
2	CPU Socket for CPU2
3	DIMM Slots (see Figure 3-5: "8-slot DIMM Numbering" on page 3-7 for details)
4	Space for 3.5" SATA Hard Drive
5	SATA Connector
6	InfiniBand Connectors (for InfiniBand cards)
7	Gbx Connectors (for power and logic to backplane)
8	MCP55 chip
9	Onboard Battery
10	KVM Module
11	BIOS Chip
12	SIMBL Slot
13	USB Port

Figure 4-4. Nvidia MCP55 Pro Chipset: Block Diagram for SBA-7121M-T1



Jumpers

The jumpers present on the mainboard are used by the manufacturer only; there are no jumpers used to configure the operation of the mainboard.

CMOS Clear

JBT1 is used to clear CMOS and will also clear any passwords. JBT1 consists of two contact pads located near the BIOS chip (#10 in [Figure 4-3](#)).

Clearing CMOS

1. First power down the blade and remove it from the enclosure.
2. Remove the blade cover to access the mainboard (see [Section : Removing/ Replacing the Blade Cover on page 3-2](#) for further details). Short the CMOS pads with a metal object such as a small screwdriver.
3. Replace the cover, install the blade back into the enclosure and power it on.

4-3 Blade Unit Components

Figure 4-5. Exploded View of SBA-7121M-T1 Blade Module

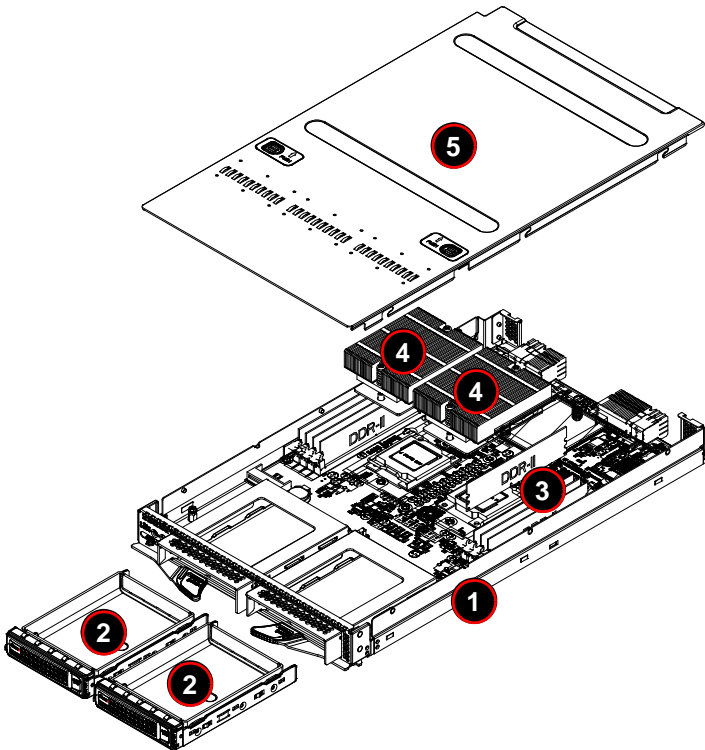

Table 4-5. Main Components of SBA-7121M-T1 Blade Unit

Item	Description
1	Blade Unit/Module
2	SATA Hard Drives (2 per blade module)
3	DIMMs (system memory)
4	CPU Heatsinks
5	Top Cover

Memory Support

The SBA-7121M-T1 blade module supports up to 64 GB of ECC Registered DDR2-800/667/533 SDRAM in eight DIMM sockets. See [Section 3-5](#) for further details on mainboard memory installation.

Hard Disk Drives

The SBA-7121M-T1 blade unit accommodates up to two 3.5" SATA hard disk drives, which are mounted in drive "carriers". The drives are hot-swappable and can be removed or replaced without powering down the blade unit they reside in. The two drives can be used to set up a RAID array (SATA RAID 0 or 1 only) or JBOD. These drives use a yellow color for the Blade HDD active LED.



WARNING: To maintain proper airflow, both hard drive bays must have drive carriers inserted during operation whether or not a drive is installed in the carrier.

Chapter 5

RAID Setup Procedure

Any blade module that supports two or more hard drives may be used to create a RAID RAID array. For Supermicro AMD processor SuperBlade modules, only the SBA-7121M-T1 blade module with two hard drives installed works for this purpose.

5-1 Preparing for Setup

Before you begin the installation, verify the following:

1. The blade module has two or more hard drives installed.
2. These drives must not have an OS installed and must be non-partitioned (formatted is ok).
3. The installation procedure is done via KVM, so have a KVM cable (CBL-0218L) connected to the KVM connector on the blade module with a keyboard, mouse and monitor attached.



NOTE: You may also instead use IPMI or the Web-based Management utility to access the blade.

5-2 Changing BIOS Settings for RAID Configuration

Use the following procedure for changing BIOS settings for RAID configuration:

1. Boot the blade and hit the <DELETE> key to enter the BIOS setup utility.
2. In the **ADVANCED SETTINGS** Menu, highlight the **SATA CONFIGURATION** option and hit <ENTER>.
3. From the **SATA Configuration** menu screen select the **NVIDIA RAID FUNCTION** setting, hit <ENTER> to open its options and select **ENABLE**.
4. Go to the **EXIT** Menu, highlight **SAVE CHANGES AND EXIT** and hit <ENTER>.

5-3 Configuring RAID in the Media Shield BIOS Utility

Use the following procedure for configuring RAID in the Media Shield BIOS Utility:

1. After exiting the BIOS utility, the blade will begin to boot up. At this time press <F10>. This brings up the **MEDIA SHIELD BIOS UTILITY** screen.
2. In the **MEDIA SHIELD BIOS UTILITY** screen, select either **MIRRORED** or **STRIPED** as your selection for the **RAID MODE** option.

3. For the DISKS selection, use the arrow keys to add drives to the ARRAY section. You must select and add at least two drives to the ARRAY section for RAID to work on the module.
4. Press <F7> to finish.
5. In the confirm message screen that appears press <Y> to confirm your selections.
6. Another confirm screen will appear asking you if you want to "Clear MBR". Press <Y> again to confirm this message.
7. Press <CTRL> + <X> to exit the program.

Chapter 6

BIOS

6-1 Introduction

This document describes the AMI® BIOS Setup utility for the SBA-7121M-T1 AMD Blade Module. The AMI ROM BIOS is stored in a flash chip and can be easily upgraded using a floppy disk-based program.

Running Setup



NOTE: Default settings are in **bold** text unless otherwise noted.

The BIOS setup options described in this section are selected by choosing the appropriate text from the MAIN BIOS SETUP screen. All displayed text is described in this section, although the screen display is often all you need to understand how to set the options.

When you first power on the computer, the BIOS is immediately activated. While the BIOS is in control, the Setup program can be activated in one of two ways:

1. By pressing <DELETE> immediately after turning the system on, or
2. When the message **Press the <Delete> key to enter Setup** appears briefly at the bottom of the screen during the POST, press the <DELETE> key to activate the main SETUP menu.

6-2 Main BIOS Setup Menu

The MAIN MENU screen has two main frames. The left frame displays all the options that can be configured. "Grayed-out" options cannot be configured. The right frame displays the key legend. Above the key legend is an area reserved for a text message. When an option is selected in the left frame, it is highlighted in white. Often a text message will accompany it.



NOTE: The BIOS has default text messages built in. SuperMicro retains the option to include, omit, or change any of these text messages.

Settings printed in **Bold** are the default values. Use the UP/DOWN arrow keys to move among the different settings in each menu. Use the LEFT/RIGHT arrow keys to change the options for each setting.

Items that use sub-menus are indicated with the ► icon. With the item highlighted, press the <ENTER> key to access the submenu.

The BIOS setup utility uses a key-based navigation system called hot keys. Most of these hot keys (<F1>, <F10>, <ENTER>, <ESC>, <ARROW> keys, and so on) can be used at any time during the setup navigation process. Press the <ESC> key to exit the CMOS SETUP menu.

When you first enter the AMI BIOS Setup utility, you will see the MAIN MENU screen. You can always return to the MAIN MENU by selecting the **Main** tab on the top of the screen with the arrow keys. The MAIN MENU screen provides you with a system overview, which includes the version, built date and ID of the AMIBIOS, the type, speed and number of the processors in the system and the amount of memory installed in the system.

System Time/System Date

You can edit the SYSTEM TIME/SYSTEM DATE field to change the system time and date. Highlight SYSTEM TIME or SYSTEM DATE using the <ARROW> keys. Enter new values through the keyboard. Press the <TAB> key or the <ARROW> keys to move between fields.

The date must be entered in **DAY/MM/DD/YYYY** format. The time is entered in **HH:MM:SS** format. Please note that time is in a 24-hour format. For example, 5:30 A.M. appears as 05:30:00 and 5:30 P.M. as 17:30:00.

6-3 Advanced Settings Menu

Choose **Advanced** from the BIOS Setup Utility main menu with the arrow keys. The items with a triangle beside them have sub menus that can be accessed by highlighting the item and pressing <ENTER>. Below is a list of all submenus in the ADVANCED SETTINGS menu:

- [BOOT Features](#)
- [CPU Configuration](#)
- [SATA Configuration](#)
- [PCI/PnP Configuration](#)
- [Super IO Configuration](#)
- [Chipset Configuration](#)
 - [NorthBridge Configuration](#)
 - [SouthBridge/MCP55 Configuration](#)
- [Event Log Configuration](#)
- [PCI Express Configuration](#)
- [Remote Access Configuration](#)
- [System Health Monitor](#)

BOOT Features

The menu options in the BOOT SETTINGS CONFIGURATION submenu and their descriptions are shown in [Table 6-1](#).

Table 6-1. BOOT Features

Menu Option	Description
Quick Boot	If ENABLED , this option will skip certain tests during POST to reduce the time needed for the system to boot up. The options are Enabled and DISABLED .
Quiet Boot	If DISABLED , normal POST messages will be displayed on boot-up. If ENABLED , this display the OEM logo instead of POST messages.
Add-On ROM Display Mode	Set this option to display add-on ROM (read-only memory) messages. The options are Force BIOS and KEEP CURRENT . The default setting is Force BIOS . <ul style="list-style-type: none"> • Select Force BIOS to allow the computer system to force a third party BIOS to display during system boot. • Select KEEP CURRENT to allow the computer system to display the BIOS information during system boot.
Bootup Num-Lock	Set this value to allow the NUMBER LOCK setting to be modified during boot up. The options are On and OFF .
Wait for 'F1' If Error	Select Enabled to activate the WAIT FOR F1 IF ERROR function. The options are Enabled and DISABLED .
Hit 'DEL' Message Display	Select Enabled to display message to hit the DEL key to enter SETUP . The options are Enabled and DISABLED .
Interrupt 19 Capture	Select Enabled to allow ROMs to trap Interrupt 19. The options are Enabled and DISABLED .
OS Installation	Change this setting if using a 64-bit Linux operating system. The available options are Other and LINUX .
▶ ACPI Configuration	
ACPI Version Features	Use this setting the determine which ACPI version to use. Options are ACPI v1.0 , ACPI v2.0 and ACPI v3.0 .
ACPI APIC Support	Determines whether to include the ACPI APIC table pointer in the RSDT pointer list. The available options are Enabled and DISABLED .
ACPI OEMB Table	Determines whether to include the ACPI APIC table pointer in the RSDT pointer list. The available options are Enabled and DISABLED .
Headless Mode	Use this setting to ENABLE or Disable headless operation mode through ACPI.
MCP55 ACPI HPET Table	Use this setting to either Enable or DISABLE the MCP55 ACPI HPET table.
▶ Power Configuration	
Power Button Mode	Allows the user to change the function of the power button. Options are On/Off and SUSPEND .
Restore on AC Power Loss	This setting allows you to choose how the system will react when power returns after an unexpected loss of power. The options are POWER OFF , POWER ON and Last State .

Table 6-1. BOOT Features (Continued)

Menu Option	Description
Watch Dog Timer	This setting is used to ENABLE or Disable the WATCH DOG TIMER function. It must be used in conjunction with the WATCH DOG jumper.
I2C Switch	Auto or DISABLE the I2C switch.
▶ MPS Configuration	
MPS Revision	This setting allows the user to select the MPS revision level. The options are 1.1 and 1.4 .
▶ Smbios Configuration	
Smbios Smi Support	This setting allows SMI wrapper support for PnP function 50h-54h. The options are Enabled and DISABLED .

CPU Configuration

The menu options in the CPU CONFIGURATION submenu and their descriptions are shown in [Table 6-2](#).

Table 6-2. CPU Configuration Submenu

Menu Option	Description
GART Error Reporting	This setting is used to Enable or Disable GART error processing.
Microcode Update	This setting is used to Enable or DISABLE microcode updates for Virtual Machine.
Secure Virtual Machine Mode	This setting is used to Enable or DISABLE processor-assisted virtualization.
Power Now	This setting is used to ENABLE or Disable the AMD Power Now feature.
Power Now	This setting is used to ENABLE or Disable the generation of ACPI _PCC, _PSS, and _PCT objects.
ACPI SRAT Table	Enable or Disable the building of an ACPI SRAT Table.
Thermal Throttling	This setting is used to ENABLE or Disable Thermal Throttling.

SATA Configuration

The menu options in the FLOPPY/IDE/SATA Configuration submenu and their descriptions are shown in [Table 6-3](#)

Table 6-3. SATA Configuration Submenu

Menu Option	Description
On-board IDE Controller	Enables or DISABLES on-board IDE controller.
Serial ATA 0	Enables or DISABLES Serial ATA 0.
nVidia RAID Function	Enables or DISABLES the nVidia RAID function in the system.

Table 6-3. SATA Configuration Submenu (Continued)

Menu Option	Description
▶ Primary IDE Master	This displays the status of Auto detection of IDE devices.
Type	Select the type. Options include: Auto , CD/DVD and ARMD
LBA/Large Mode	Sets LBA Large Mode. Options are DISABLED and Auto .
Block (Multi-Sector Transfer)	This sets the data transfer rate from or to the device. Options are Auto (for multiple sectors) and DIABLE (for one sector at a time).
PIO Mode	This sets the PIO mode. Options are Auto , 0, 1, 2, 3 or 4.
DMA Mode	This set the DMA mode. Options are Auto , 0, 1, 2, 3 or 4.
S.M.A.R.T.	Sets the S.M.A.R.T. mode. Options are Auto , DISABLE and ENABLE.
32-bit Data Transfer	Enables or DISABLES 32-bit data transfer.
▶ Serial ATA 0 Primary Channel	While entering BIOS, it auto detects the presence of IDE devices. This displays the status of auto detection of IDE devices.
LBA/Large Mode	Sets LBA Large Mode. Options are DISABLED and Auto .
Block (Multi-Sector Transfer)	This sets the data transfer rate from or to the device. Options are Auto (for multiple sectors) and DIABLE (for one sector at a time).
PIO Mode	This sets the PIO mode. Options are Auto , 0, 1, 2, 3 or 4.
DMA Mode	This set the DMA mode. Options are Auto , 0, 1, 2, 3 or 4.
S.M.A.R.T.	Sets the S.M.A.R.T. mode. Options are Auto , DISABLE and ENABLE.
32-bit Data Transfer	Enables or DISABLES 32-bit data transfer.
▶ Serial ATA 0 Secondary Channel	While entering BIOS, it auto detects the presence of IDE devices. This displays the status of auto detection of IDE devices.
LBA/Large Mode	Sets LBA Large Mode. Options are DISABLED and Auto .
Block (Multi-Sector Transfer)	This sets the data transfer rate from or to the device. Options are Auto (for multiple sectors) and DIABLE (for one sector at a time).
PIO Mode	This sets the PIO mode. Options are Auto , 0, 1, 2, 3 or 4.
DMA Mode	This set the DMA mode. Options are Auto , 0, 1, 2, 3 or 4.
S.M.A.R.T.	Sets the S.M.A.R.T. mode. Options are Auto , DISABLE and ENABLE.
32-bit Data Transfer	Enables or DISABLES 32-bit data transfer.
Hard Disk Write Protect	Disable/ Enable device write protection. This will be effective only if device is accessed through BIOS.

PCI/PnP Configuration

The menu options in the PCI/PNP CONFIGURATION submenu and their descriptions are shown in [Table 6-4](#).

Table 6-4. PCI/PnP Configuration Submenu

Menu Option	Description
Clear NVRAM	Select YES to clear NVRAM during boot-up. The options are YES and No .
Plug & Play OS	Select YES to allow the OS to configure Plug & Play devices. NOTE: Selecting YES is not required for system boot if your system has an OS that supports Plug & Play. Select No to allow AMIBIOS to configure all devices in the system.
PCI Latency Timer	This option sets the latency of all PCI devices on the PCI bus. Select a value to set the PCI latency in PCI clock cycles. Options are 32, 64 , 96, 128, 160, 192, 224 and 248.
Allocate IRQ to PCI VGA	Set this value to allow or restrict the system from giving the VGA adapter card an interrupt address. The options are Yes and No.
Palette Snooping	Select ENABLED to inform the PCI devices that an ISA graphics device is installed in the system in order for the graphics card to function properly. The options are ENABLED and Disabled .
IRQ3/IRQ4/IRQ5/ IRQ7/IRQ9/IRQ10/ IRQ11/IRQ14/IRQ15	This feature specifies the availability of an IRQ to be used by a PCI/PnP device. Select RESERVED for the IRQ to be used by a Legacy ISA device. The options are Available and RESERVED.
DMA Channel 0/ Channel 1/Channel 3/ Channel 5/Channel 6/ Channel 7	Select Available to indicate that a specific DMA channel is available to be used by a PCI/PnP device. Select RESERVED if the DMA channel specified is reserved for a Legacy ISA device. The options are Available and Reserved.
Reserved Memory Size	You may set reserved memory with this setting. The options are Disabled , 16k, 32k and 64k.

Super IO Configuration

The menu options in the SUPER IO CONFIGURATION submenu and their descriptions are shown in [Table 6-5](#).

Table 6-5. Super IO Configuration Submenu

Menu Option	Description
Serial Port1 Address	<p>This option specifies the base I/O port address and Interrupt Request address of serial port 1. The options are DISABLED, 3F8/IRQ4, 3E8/IRQ4 and 2E8/IRQ3.</p> <ul style="list-style-type: none"> • Select DISABLED to prevent the serial port from accessing any system resources. When this option is set to DISABLED, the serial port physically becomes unavailable. • Select 3F8/IRQ4 to allow the serial port to use 3F8 as its I/O port address and IRQ 4 for the interrupt address.
Serial Port2 Address	<p>This option specifies the base I/O port address and Interrupt Request address of serial port 2. The options are DISABLED, 2F8/IRQ3, 3E8/IRQ4 and 2E8/IRQ3. Select DISABLED to prevent the serial port from accessing any system resources. When this option is set to DISABLED, the serial port physically becomes unavailable.</p> <p>Select 2F8/IRQ3 to allow the serial port to use 2F8 as its I/O port address and IRQ 3 for the interrupt address.</p>
Serial Port 2 Mode	<p>This tells the BIOS which mode to select for serial port 2. The options are Normal, IRDA and ASKIR.</p>

Chipset Configuration

The CHIPSET CONFIGURATION submenu contains two submenus as shown in [Table 6-6](#).

Table 6-6. Chipset Configuration Submenu

Menu Option	Description
▶ NorthBridge Configuration	This menu option configures the NorthBridge Chip. For details see Table 6-7 .
▶ SouthBridge/MCP55 Configuration	This menu option configures the SouthBridge/MCP55 Chip. For details see Table 6-8 .

NorthBridge Configuration

The menu options in the NORTHBRIDGE CONFIGURATION submenu and their descriptions are shown in [Table 6-7](#).

Table 6-7. NorthBridge Configuration Submenu

Menu Option	Description
▶ Memory Configuration	
Bank Interleaving	Select Auto to automatically enable interleaving-memory scheme when this function is supported by the processor. The options are Auto and Disabled.

Table 6-7. NorthBridge Configuration Submenu (Continued)

Menu Option	Description
Channel Interleaving	Enables channel memory interleaving. Options include: Disabled , ADDRESS BITS 6, ADDRESS BITS 12, RESERVED, XOR OF ADDRESS BITS [20:16, 6], XOR OF ADDRESS BITS [20:16, 9].
Enable Clock to All DIMMs	Use this setting to enable unused clocks to all DIMMs, even if some DIMM slots are unpopulated. Options are ENABLED and Disabled .
Mem Clk Tristate C3/ALTVID	Use this setting to ENABLE or Disable memory clock tristate during C3 and ALT VID.
Memory Hole Remapping	When ENABLED, this feature enables hardware memory remapping around the memory hole. Options are Enabled and DISABLED.
CS Sparing Enable	Use this setting to ENABLE or Disable the CS Sparing function.
DCT Unganged Mode	This allows selection of unganged DRAM mode (64-bit width). Options are Auto (Ganged Mode) and ALWAYS (unganged mode).
Power Down Enable	Enable or DISABLE DDR power down mode.
Power Down Mode	Set DDR power down mode to Channel or CHIP SELECT.
► ECC Configuration	
ECC Mode	<p>DRAM ECC allows hardware to report and correct memory errors automatically. Options are Enabled and DISABLED.</p> <ul style="list-style-type: none"> 4-Bit ECC Mode – Allows you to enable 4-bit ECC mode (also known as ECC Chipkill). Options are ENABLED and Disabled. DRAM Scrub Redirect – Allows the system to correct DRAM ECC errors immediately, even with background scrubbing on. Options are ENABLED and Disabled. DRAM BG Scrub – Corrects memory errors so later reads are correct. Options are Disabled and various times in nanoseconds and microseconds.
Alternate VID	Specifies and alternate VID while in low power states. Options are Auto and various voltages between .8V and 1.115V.
Memory Timing Parameters	Allows the user to select which CPU Node's timing parameters (memory clock, etc.) to display. Options are CPU Node 0 , CPU NODE 1, CPU NODE 2 and CPU NODE 3.
► DRAM Timing Configuration	
Memory Clock Mode	Set the Memory Clock Mode. Options are Auto , LIMIT and MANUAL.
DRAM Timing Mode	Set the DRAM Timing Mode. Options are Auto , DCT0, DCT1 and BOTH.

SouthBridge/MCP55 Configuration

The menu options in the SOUTHBRIDGE/MCP55 CONFIGURATION submenu and their descriptions are shown in [Table 6-8](#).

Table 6-8. SouthBridge/MCP55 Configuration Submenu

Menu Option	Description
CPU/LDT Spread Spectrum	Enables spread spectrum for the CPU/LDT. Options are Center Spread , DOWN SPREAD or DISABLED.
PCIe Spread Spectrum	Allows you to Enable or DISABLE spread spectrum for PCI-Express.
SATA Spread Spectrum	Enables spread spectrum for the SATA. Options are Enabled and DISABLED.
Primary Graphics Adapter	Options are PCI Express → PCI and PCI ≠ PCI EXPRESS.
USB 1.1 Controller	Enable or DISABLE the USB 1.1 controller.
USB 2.0 Controller	Enable or DISABLE the USB 2.0 controller.
USB Devices Enabled	This menu option is greyed out and cannot be configured by the user.
Legacy USB Support	Select Enabled to enable the support for USB Legacy. Disable Legacy support if there are no USB devices installed in the system. AUTO disables Legacy support if no USB devices are connected. The options are DISABLED, Enabled and AUTO.
USB 2.0 Controller Mode	Select the controller mode for your USB ports. Options are HiSpeed and FULLSPEED. (HiSpeed=480 Mbps, FullSpeed=12 Mbps).
BIOS EHCI Hand-Off	Enable or DISABLE a workaround for OS's without EHCI hand-off support.
▶ USB Mass Storage Device Configuration	
USB Mass Storage Reset Delay	This sets the number of seconds POST waits for the USB mass storage device after the START unit command. Options are 10 SEC, 20 sec , 30 SEC AND 40 SEC.
▶ Emulation Type	
Device 1 Emulation Type	Options for all include Auto , FLOPPY, FORCED FDD, HARD DISK and CDROM. If Auto , then USB devices less than 530 MB will be emulated as floppy and remaining as hard drive. Forced FDD option can be used to force HDD formatted drive to boot as an FDD (example: ZIP Drive).
Device 2 Emulation Type	
Device 3 Emulation Type	
Device 4 Emulation Type	

Event Log Configuration

The menu options in the EVENT LOG CONFIGURATION submenu and their descriptions are shown in [Table 6-9](#).

Table 6-9. Event Log Configuration Submenu

Menu Option	Description
View Event Log	Highlight this item and press <ENTER> to view the contents of the event log.
Mark All Events as Read	Highlight this item and press <ENTER> to mark all events as read.
Clear Event Log	Select Yes and press <ENTER> to clear all event logs. The options are YES and NO to verify.

PCI Express Configuration

The PCI EXPRESS CONFIGURATION submenu contains a single menu option as shown in [Table 6-10](#).

Table 6-10. PCI Express Configuration Submenu

Menu Option	Description
Active State Power Management	Used to ENABLE or Disable the PCI L0 and L1 link power states.

Remote Access Configuration

The menu options in the REMOTE ACCESS CONFIGURATION submenu and their descriptions are shown in [Table 6-11](#).

Table 6-11. Remote Access Configuration Submenu

Menu Option	Description
Remote Access	Allows you to ENABLE or Disable remote access. If enabled, the settings below will appear.
Serial Port Number	Selects the serial port to use for console redirection. Options are COM1 and COM2 .
Serial Port Mode	Selects the serial port settings to use. Options are (115200 8, n, 1) , (57600 8, N, 1), (38400 8, N, 1), (19200 8, N, 1) AND (09600 8, N, 1).
Flow Control	Selects the flow control to be used for console redirection. Options are None , HARDWARE and SOFTWARE .
Redirection After BIOS POST	Options are DISABLE (no redirection after BIOS POST), BOOT LOADER (redirection during POST and during boot loader) and Always (redirection always active). Note that some OS's may not work with this set to Always.
Terminal Type	Selects the type of the target terminal: ANSI , VT100 and VT-UTF8 .

Table 6-11. Remote Access Configuration Submenu (Continued)

Menu Option	Description
VT-UTF8 Combo Key Support	Allows you to Enable or DISABLE VT-UTF8 combination key support for ANSI/VT100 terminals.
Sredir Memory Display Delay	Use this setting to set the delay in seconds to display memory information. Options are No Delay , 1 SEC, 2 SECS and 4 SECS.

System Health Monitor

The SYSTEM HEALTH MONITOR submenu's menu option is shown in [Table 6-12](#).

Table 6-12. System Health Monitor Submenu

Menu Option	Description
CPU Overheat Temperature	Use the "+" and "-" keys to set the CPU temperature threshold to between 65° and 90° C. When this threshold is exceeded, the overheat LED on the chassis will light up and an alarm will sound. The LED and alarm will turn off once the CPU temperature has dropped to 5 degrees below the threshold set. The default setting is 72o C .

Other items in the submenu are systems monitor displays for the following information: CPU1 TEMPERATURE, CPU2 TEMPERATURE, CPU3 TEMPERATURE, CPU4 TEMPERATURE, (for 4U systems), SYSTEM TEMPERATURE, CPU1 VCORE, CPU2 VCORE, CPU3 VCORE, CPU4 VCORE (for 4U systems), 3.3V VCC, +5VIN, +12VIN, 5V STANDBY and BATTERY VOLTAGE.

6-4 Boot Menu

The menu options for the BOOT menu are shown in [Table 6-13](#).

Table 6-13. Boot Menu

Menu Option	Description
► Boot Device Priority	This feature allows the user to prioritize the boot sequence from the available devices. The devices to set are: <ul style="list-style-type: none"> • 1ST BOOT DEVICE • 2ND BOOT DEVICE • 3RD BOOT DEVICE • 4TH BOOT DEVICE
► Hard Disk Drives	This feature allows the user to specify the boot sequence from available hard disk drives.
1st Drive	Specifies the boot sequence for the 1st Hard Drive.
► Removable Drives	This feature allows the user to specify the boot sequence from available removable drives.
1st Drive	Specifies the boot sequence for the 1st Removable Drive. The options are USB: PeppCMM Virtual Disc 1 , USB: PEPPCMM VIRTUAL DISC 2 and DISABLED .

Table 6-13. Boot Menu

Menu Option	Description
2nd Drive	Specifies the boot sequence for the 1st Removable Drive. The options are USB: PeppCMM Virtual Disc 1 , USB: PEPPCMM VIRTUAL DISC 2 and DISABLED.
► CD/DVD Drives	This feature allows the user to specify the boot sequence from available CD or DVD disc drives.
1st Drive	Specifies the boot sequence for the 1st CD/DVD Drive. The options are USB: PeppCMM Virtual Disc 1 , USB: PEPPCMM VIRTUAL DISC 2 and DISABLED.
2nd Drive	Specifies the boot sequence for the 1st CD/DVD Drive. The options are USB: PeppCMM Virtual Disc 1 , USB: PEPPCMM VIRTUAL DISC 2 and DISABLED.

6-5 Security Menu

The menu options for the SECURITY menu are shown in [Table 6-14](#).

The AMI BIOS provides a **Supervisor** and a **User** password. If you use both passwords, the Supervisor password must be set first.

Table 6-14. Security Menu

Menu Option	Description
Change Supervisor Password	Select this option and press <ENTER> to access the sub menu, and then type in the password.
Change User Password	Select this option and press <ENTER> to access the sub menu, and then type in the password.
Boot Sector Virus Protection	<p>This option is near the bottom of the SECURITY SETUP screen. The options are ENABLED and Disabled.</p> <ul style="list-style-type: none"> Select DISABLED to deactivate the Boot Sector Virus Protection. Select ENABLED to enable boot sector protection. <p>When ENABLED, the AMI BIOS displays a warning when any program (or virus) issues a <i>Disk Format</i> command or attempts to write to the boot sector of the hard disk drive.</p>

6-6 Exit Menu

Select the EXIT tab from AMI BIOS SETUP UTILITY screen to enter the EXIT BIOS SETUP screen. The options for the EXIT menu are shown in [Table 6-15](#). You may also additionally press <Esc> to exit without saving or <F10> to save your settings and exit.

Table 6-15. Exit Menu

Menu Option	Description
Save Changes and Exit	When you have completed the system configuration changes, select this option to leave BIOS Setup and reboot the computer, so the new system configuration parameters can take effect. Select SAVE CHANGES AND EXIT from the EXIT menu and press <ENTER>.
Discard Changes and Exit	Select this option to quit BIOS Setup without making any permanent changes to the system configuration and reboot the computer. Select DISCARD CHANGES AND EXIT from the EXIT menu and press <ENTER>.
Discard Changes	Select this option and press <ENTER> to discard all the changes and return to AMI BIOS Utility Program.
Load Optimal Defaults	To set this feature, select LOAD OPTIMAL DEFAULTS from the EXIT menu and press <ENTER>. Then Select OK to allow BIOS to automatically load the OPTIMAL DEFAULTS as the BIOS Settings. The OPTIMAL SETTINGS are designed for maximum system performance, but may not work best for all computer applications.
Load Fail-Safe Defaults	To set this feature, select LOAD FAIL-SAFE DEFAULTS from the EXIT menu and press <ENTER>. The FAIL-SAFE settings are designed for maximum system stability, but not maximum performance.

Notes

Appendix A

BIOS POST Codes

A-1 BIOS POST Messages

During the Power-On Self-Test (POST), the BIOS will check for problems. If a problem is found, the BIOS will activate an alarm or display a message. The following is a list of such BIOS messages.

Table A-1. BIOS POST Messages

BIOS Message	Description
Failure Fixed Disk	Fixed disk is not working or not configured properly. Check to see if fixed disk is attached properly. Run Setup. Find out if the fixed-disk type is correctly identified.
Stuck key	Stuck key on keyboard.
Keyboard error	Keyboard not working.
Keyboard Controller Failed	Keyboard controller failed test. May require replacing keyboard controller.
Keyboard locked - Unlock key switch	Unlock the system to proceed.
Monitor type does not match CMOS - Run SETUP	Monitor type not correctly identified in Setup
Shadow Ram Failed at offset: nnnn	Shadow RAM failed at offset nnnn of the 64k block at which the error was detected.
System RAM Failed at offset: nnnn	System RAM failed at offset nnnn of in the 64k block at which the error was detected.
Extended RAM Failed at offset: nnnn	Extended memory not working or not configured properly at offset nnnn .
System battery is dead - Replace and run SETUP	The CMOS clock battery indicator shows the battery is dead. Replace the battery and run Setup to reconfigure the system.
System CMOS checksum bad - Default configuration used	System CMOS has been corrupted or modified incorrectly, perhaps by an application program that changes data stored in CMOS. The BIOS installed Default Setup Values. If you do not want these values, enter Setup and enter your own values. If the error persists, check the system battery or contact your dealer.
System timer error	The timer test failed. Requires repair of system board.
Real time clock error	Real-Time Clock fails BIOS hardware test. May require board repair.
Check date and time settings	BIOS found date or time out of range and reset the Real-Time Clock. May require setting legal date (1991-2099).

Table A-1. BIOS POST Messages (Continued)

BIOS Message	Description
Previous boot incomplete - Default configuration used	Previous POST did not complete successfully. POST loads default values and offers to run Setup. If the failure was caused by incorrect values and they are not corrected, the next boot will likely fail. On systems with control of wait states , improper Setup settings can also terminate POST and cause this error on the next boot. Run Setup and verify that the waitstate configuration is correct. This error is cleared the next time the system is booted.
Memory Size found by POST differed from CMOS	Memory size found by POST differed from CMOS.
Diskette drive A error Diskette drive B error	Drive A: or B: is present but fails the BIOS POST diskette tests. Check to see that the drive is defined with the proper diskette type in Setup and that the diskette drive is attached correctly.
Incorrect Drive A type - run SETUP	Type of floppy drive A: not correctly identified in Setup.
Incorrect Drive B type - run SETUP	Type of floppy drive B: not correctly identified in Setup.
System cache error - Cache disabled	RAM cache failed and BIOS disabled the cache. On older boards, check the cache jumpers. You may have to replace the cache. See your dealer. A disabled cache slows system performance considerably.
CPU ID:	CPU socket number for Multi-Processor error.
EISA CMOS not writeable	ServerBIOS2 test error: Cannot write to EISA CMOS.
DMA Test Failed	ServerBIOS2 test error: Cannot write to extended DMA (Direct Memory Access) registers.
Software NMI Failed	ServerBIOS2 test error: Cannot generate software NMI (Non-Maskable Interrupt).
Fail-Safe Timer NMI Failed	ServerBIOS2 test error: Fail-Safe Timer takes too long.
device Address Conflict	Address conflict for specified device .
Allocation Error for: device	Run ISA or EISA Configuration Utility to resolve resource conflict for the specified device .
CD ROM Drive	CD ROM Drive identified.
Entering SETUP...	Starting Setup program
Failing Bits: nnnn	The hex number nnnn is a map of the bits at the RAM address which failed the memory test. Each 1 (one) in the map indicates a failed bit. See errors 230, 231, or 232 above for offset address of the failure in System, Extended, or Shadow memory.
Fixed Disk n	Fixed disk n (0-3) identified.
Invalid System Configuration Data	Problem with NVRAM (CMOS) data.
I/O device IRQ conflict	I/O device IRQ conflict error.
PS/2 Mouse Boot Summary Screen:	PS/2 Mouse installed.

Table A-1. BIOS POST Messages (Continued)

BIOS Message	Description
nxxx kB Extended RAM Passed	Where xxxx is the amount of RAM in kilobytes successfully tested.
nxxx Cache SRAM Passed	Where xxxx is the amount of system cache in kilobytes successfully tested.
xxxx kB Shadow RAM Passed	Where xxxx is the amount of shadow RAM in kilobytes successfully tested.
xxxx kB System RAM Passed	Where xxxx is the amount of system RAM in kilobytes successfully tested.
One or more I2O Block Storage Devices were excluded from the Setup Boot Menu	There was not enough room in the IPL table to display all installed I2O block-storage devices.
Operating system not found	Operating system cannot be located on either drive A: or drive C:. Enter Setup and see if fixed disk and drive A: are properly identified.
Parity Check 1 nxxx	Parity error found in the system bus. BIOS attempts to locate the address and display it on the screen. If it cannot locate the address, it displays ???? . Parity is a method for checking errors in binary data. A parity error indicates that some data has been corrupted.
Parity Check 2 nxxx	Parity error found in the I/O bus. BIOS attempts to locate the address and display it on the screen. If it cannot locate the address, it displays ???? .
Press <F1> to resume, <F2> to Setup, <F3> for previous	Displayed after any recoverable error message. Press <F1> to start the boot process or <F2> to enter Setup and change the settings. Press <F3> to display the previous screen (usually an initialization error of an Option ROM , i.e., an add-on card). Write down and follow the information shown on the screen.
Press <F2> to enter Setup	Optional message displayed during POST. Can be turned off in Setup.
PS/2 Mouse:	PS/2 mouse identified.
Run the I2O Configuration Utility	One or more unclaimed block storage devices have the Configuration Request bit set in the LCT. Run an I2O Configuration Utility (e.g. the SAC utility).
System BIOS shadowed	System BIOS copied to shadow RAM.
UMB upper limit segment address: nxxx	Displays the address xxxx of the upper limit of Upper Memory Blocks , indicating released segments of the BIOS which can be reclaimed by a virtual memory manager.
Video BIOS shadowed	Video BIOS successfully copied to shadow RAM.

A-2 BIOS POST Codes

This section lists the POST (Power-On Self-Test) codes for the AMI BIOS. POST codes are divided into two categories: recoverable and terminal.

Recoverable POST Errors

When a recoverable type of error occurs during POST, the BIOS will display an POST code that describes the problem. BIOS may also issue one of the following beep codes:

- **One long and two short beeps** – video configuration error
- **One repetitive long beep** – no memory detected

Terminal POST Errors

If a terminal type of error occurs, BIOS will shut down the system. Before doing so, BIOS will write the error to *port 80h*, attempt to initialize video and write the error in the top left corner of the screen.

The following is a list of codes that may be written to *port 80h*.

Table A-2. Terminal POST Errors

Post Code	Description
02h	Verify Real Mode
03h	Disable Non-Maskable Interrupt (NMI)
04h	Get CPU type
06h	Initialize system hardware
07h	Disable shadow and execute code from the ROM.
08h	Initialize chipset with initial POST values
09h	Set IN POST flag
0Ah	Initialize CPU registers
0Bh	Enable CPU cache
0Ch	Initialize caches to initial POST values
0Eh	Initialize I/O component
0Fh	Initialize the local bus IDE
10h	Initialize Power Management
11h	Load alternate registers with initial POST values
12h	Restore CPU control word during warm boot
13h	Initialize PCI Bus Mastering devices
14h	Initialize keyboard controller
16h	1-2-2-3 BIOS ROM checksum
17h	Initialize cache before memory Auto size
18h	8254 timer initialization
1Ah	8237 DMA controller initialization
1Ch	Reset Programmable Interrupt Controller
20h	1-3-1-1 Test DRAM refresh

Table A-2. Terminal POST Errors (Continued)

Post Code	Description
22h	1-3-1-3 Test 8742 Keyboard Controller
28h	Auto size DRAM
29h	Initialize POST Memory Manager
2Ah	Clear 512 kB base RAM
2Ch	1-3-4-1 RAM failure on address line xxxx*
2Eh	1-3-4-3 RAM failure on data bits xxxx* of low byte of memory bus
2Fh	Enable cache before system BIOS shadow
32h	Test CPU bus-clock frequency
33h	Initialize Phoenix Dispatch Manager
36h	Warm start shut down
38h	Shadow system BIOS ROM
3Ah	Auto size cache
3Ch	Advanced configuration of chipset registers
3Dh	Load alternate registers with CMOS values
41h	Initialize extended memory for RomPilot
42h	Initialize interrupt vectors
45h	POST device initialization
46h	2-1-2-3 Check ROM copyright notice
47h	Initialize I20 support
48h	Check video configuration against CMOS
49h	Initialize PCI bus and devices
4Ah	Initialize all video adapters in system
4Bh	QuietBoot start (optional)
4Ch	Shadow video BIOS ROM
4Eh	Display BIOS copyright notice
4Fh	Initialize MultiBoot
50h	Display CPU type and speed
51h	Initialize EISA board
52h	Test keyboard
54h	Set key click if enabled
55h	Enable USB devices
58h	2-2-3-1 Test for unexpected interrupts
59h	Initialize POST display service
5Ah	Display prompt "Press F2 to enter SETUP"
5Bh	Disable CPU cache

Table A-2. Terminal POST Errors (Continued)

Post Code	Description
5Ch	Test RAM between 512 and 640 kB
60h	Test extended memory
62h	Test extended memory address lines
64h	Jump to UserPatch1
66h	Configure advanced cache registers
67h	Initialize Multi Processor APIC
68h	Enable external and CPU caches
69h	Setup System Management Mode (SMM) area
6Ah	Display external L2 cache size
6Bh	Load custom defaults (optional)
6Ch	Display shadow-area message
6Eh	Display possible high address for UMB recovery
70h	Display error messages
72h	Check for configuration errors
76h	Check for keyboard errors
7Ch	Set up hardware interrupt vectors
7Dh	Initialize Intelligent System Monitoring
7Eh	Initialize coprocessor if present
80h	Disable onboard Super I/O ports and IRQs
81h	Late POST device initialization
82h	Detect and install external RS232 ports
83h	Configure non-MCD IDE controllers
84h	Detect and install external parallel ports
85h	Initialize PC-compatible PnP ISA devices
86h	Re-initialize onboard I/O ports.
87h	Configure Motherboard Configurable Devices (optional)
88h	Initialize BIOS Data Area
89h	Enable Non-Maskable Interrupts (NMIs)
8Ah	Initialize Extended BIOS Data Area
8Bh	Test and initialize PS/2 mouse
8Ch	Initialize floppy controller
8Fh	Determine number of ATA drives (optional)
90h	Initialize hard-disk controllers
91h	Initialize local-bus hard-disk controllers
92h	Jump to UserPatch2

Table A-2. Terminal POST Errors (Continued)

Post Code	Description
93h	Build MPTABLE for multi-processor boards
95h	Install CD ROM for boot
96h	Clear huge ES segment register
98h	1-2 Search for option ROMs. One long, two short beeps on check-sum failure
99h	Check for SMART Drive (optional)
9Ah	Shadow option ROMs
9Ch	Set up Power Management
9Dh	Initialize security engine (optional)
9Eh	Enable hardware interrupts
9Fh	Determine number of ATA and SCSI drives
A0h	Set time of day
A2h	Check key lock
A4h	Initialize typematic rate
A8h	Erase F2 prompt
AAh	Scan for F2 key stroke
ACh	Enter SETUP
A Eh	Clear Boot flag
B0h	Check for errors
B1h	Inform RomPilot about the end of POST.
B2h	POST done - prepare to boot operating system
B4h	1 One short beep before boot
B5h	Terminate QuietBoot (optional)
B6h	Check password (optional)
B7h	Initialize ACPI BIOS
B9h	Prepare Boot
BAh	Initialize SMBIOS
BBh	Initialize PnP Option ROMs
BCh	Clear parity checkers
BDh	Display MultiBoot menu
BEh	Clear screen (optional)
BFh	Check virus and backup reminders
C0h	Try to boot with INT 19
C1h	Initialize POST Error Manager (PEM)
C2h	Initialize error logging
C3h	Initialize error display function

Table A-2. Terminal POST Errors (Continued)

Post Code	Description
C4h	Initialize system error handler
C5h	PnPnd dual CMOS (optional)
C6h	Initialize note dock (optional)
C7h	Initialize note dock late
C8h	Force check (optional)
C9h	Extended checksum (optional)
CAh	Redirect Int 15h to enable remote keyboard
CBh	Redirect Int 13h to Memory Technologies Devices such as ROM, RAM, PCMCIA, and serial disk
CCh	Redirect Int 10h to enable remote serial video
CDh	Re-map I/O and memory for PCMCIA
CEh	Initialize digitizer and display message
D2h	Unknown interrupt

The following are for the boot block in Flash ROM:

Table A-3. Boot Block Flash ROM Terminal POST Errors

Post Code	Description
E0h	Initialize the chipset
E1h	Initialize the bridge
E2h	Initialize the CPU
E3h	Initialize system timer
E4h	Initialize system I/O
E5h	Check force recovery boot
E6h	Checksum BIOS ROM
E7h	Go to BIOS
E8h	Set Huge Segment
E9h	Initialize Multi Processor
EAh	Initialize OEM special code
EBh	Initialize PIC and DMA
ECh	Initialize Memory type
EDh	Initialize Memory size
EEh	Shadow Boot Block
EFh	System memory test
F0h	Initialize interrupt vectors
F1h	Initialize Run Time Clock

:

Table A-3. Boot Block Flash ROM Terminal POST Errors (Continued)

Post Code	Description
F2h	Initialize video
F3h	Initialize System Management Manager
F4h	Output one beep
F5h	Clear Huge Segment
F6h	Boot to Mini DOS
F7h	Boot to Full DOS

If the BIOS detects error 2C, 2E, or 30 (base 512K RAM error), it displays an additional word-bitmap (**xxxx**) indicating the address line or bits that failed. For example, "2C 0002" means address line 1 (bit one set) has failed. "2E 1020" means data bits 12 and 5 (bits 12 and 5 set) have failed in the lower 16 bits. The BIOS also sends the bitmap to the port-80 LED display. It first displays the checkpoint code, followed by a delay, the high-order byte, another delay, and then the low order byte of the error. It repeats this sequence continuously.

Notes

Disclaimer

The products sold by Supermicro are not intended for and will not be used in life support systems, medical equipment, nuclear facilities or systems, aircraft, aircraft devices, aircraft/emergency communication devices or other critical systems whose failure to perform be reasonably expected to result in significant injury or loss of life or catastrophic property damage. Accordingly, Supermicro disclaims any and all liability, and should buyer use or sell such products for use in such ultra-hazardous applications, it does so entirely at its own risk. Furthermore, buyer agrees to fully indemnify, defend and hold Supermicro harmless for and against any and all claims, demands, actions, litigation, and proceedings of any kind arising out of or related to such ultra-hazardous use or sale.
