

Information for Lot 9 of ErP (Ecodesign)

This addendum addresses European Union (EU) Ecodesign requirements for servers and storage products. All data and ratings within this addendum are in reference only to the Supermicro product(s) in the manual. The below information conforms to requirements laid down in Annex II of the Commission Regulation 2019/424.

- 3(1)(a): See Section 1.1 of the system manual for the product type.
- 3(1)(b): See the title page and preface of the system manual for the trademark and manufacturer's address.
- 3(1)(c): See the title page of the system manual for product model number(s).
- 3(1)(d): See the serial number on the physical system to determine the year of manufacture.
- 3(1)(e-j): **PSU Efficiency and Power Factor Value (Table) (From 80 Plus report)**

PSU Model #: PWS-5K26G-2R1 Watts: 5250W	PSU Efficiency				Power Factor
% of Rated Load	10%	20%	50%	100%	50%
Single Output (AC-DC)	92.38%	94.48%	96.40%	95.56%	0.9957

System (EUT) Efficiency in Idle State Power (Table)

Representative Configurations	Measured Idle State Power (W)	Calculated Idle Power Allowance (W)
High-End Performance Configuration	1045.9	1110.9485
Typical Configuration	N/A	N/A
Low-End Performance Configuration	912.5	763.6835

System (EUT) Efficiency in Active State Power (Table)

Representative Configurations	Active State Efficiency Score (Effserver)	Minimum Active State Efficiency for 2-Socket Server
High-End Performance Configuration	63.7	9.5
Typical Configuration	N/A	
Low-End Performance Configuration	45	

3(1)(k): The operating condition class is **A2**.

Operating condition class	Dry bulb temp °C		Humidity range, non-condensing		Max dew point (°C)	Maximum rate of change (°C/hr)
	Allowable range	Recommended range	Allowable range	Recommended range		
A1	15-32	18-27	- 12 °C Dew Point (DP) and 8 % relative humidity (RH) to 17 °C DP and 80 % RH	- 9 °C DP to 15 °C DP and 60 % RH	17	5/20
A2	10-35	18-27	- 12 °C DP and 8 % RH to 21 °C DP and 80 % RH	Same as A1	21	5/20
A3	5-40	18-27	- 12 °C DP and 8 % RH to 24 °C DP and 85 % RH	Same as A1	24	5/20
A4	5-45	18-27	- 12 °C DP and 8 % RH to 24 °C DP and 90 % RH	Same as A1	24	5/20

3(1)(l): The idle state power at the higher boundary temperature of the operating conditions class is 1234.162 W.

3(1)(m): The active state efficiency and performance is 63.7.

3(1)(n): The user performing secure data deletion should be an IT professional.

The method is through the secure data deletion tool provided by the original manufacturer of the hard drive. Each manufacturer should have the tool available on their website. If needed, please look on the hard drive label for the name of the manufacturer and model information.

3(1)(o): List of recommended combinations of blade servers with chassis: N/A.

3(1)(p): List of all current SKUs within this product family: SYS-A22GA-NBRT.

3(3)(a): There is no use of cobalt in batteries in this product.

The indicative weight range of neodymium in the HDD is 0.0 if manufactured by Western Digital, and is between 5-25 grams if manufactured by Seagate.

3(3)(b): Please see the disassembly instructions on the next page.

Illustrated System Disassembly Instructions

Please note: All the illustrations in the below disassembly instructions are for demonstration only. Components shown here may not match exactly with the components in your system.

CAUTION: Always power off the system and unplug the power cord(s) first before disassembling the system!

1. GPU Drawer Cover

Type and number of fastenings: Four (4) Phillips screws.

Tools required: Screwdriver with PH2 bit.

Procedure:

1. First, remove the drawer from the chassis and remove the screws securing the cover to the GPU drawer.
2. Slide the cover toward the rear of the chassis.
3. Lift the top cover off the chassis.

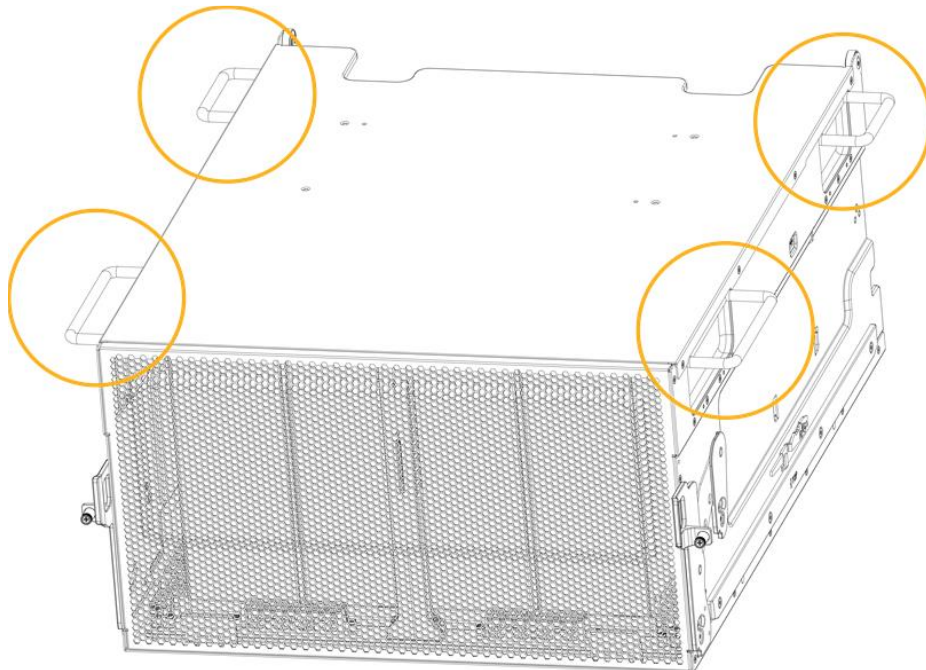

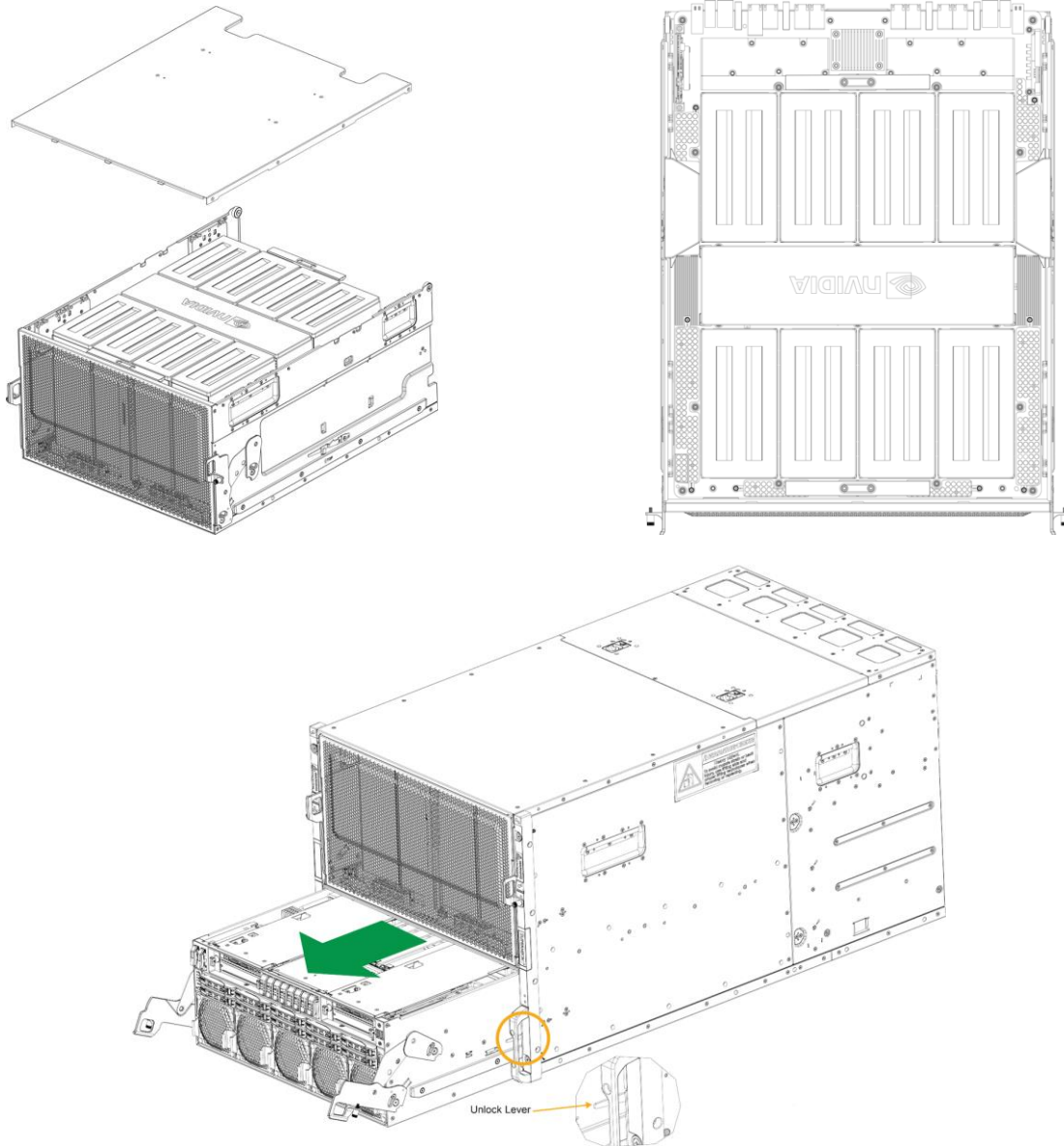

2. Processor

Type and number of fastenings: Four (4) T30 Torx screws.

Tools required: Screwdriver with T30 Torx bit.

Procedure:

1. Use a screwdriver to loosen the four screws in a diagonal pattern.

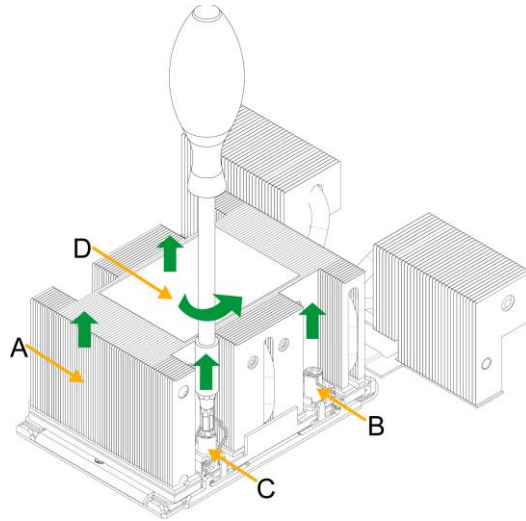

2. Press the four rotating wires outward to unlatch the processor heatsink module from the socket.

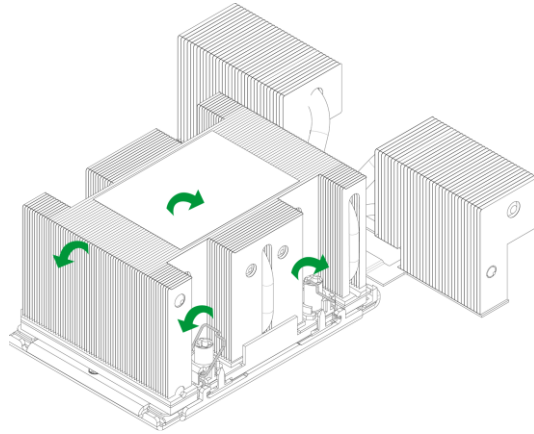

3. Gently lift the processor heatsink module upward to remove it from the socket.

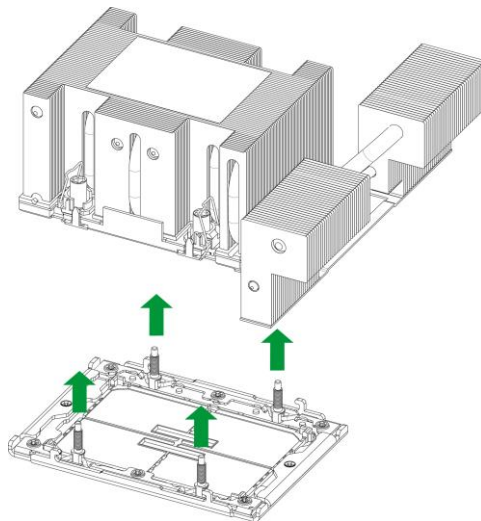

4. To remove the processor from the heatsink, gently lift the lever from the processor carrier.

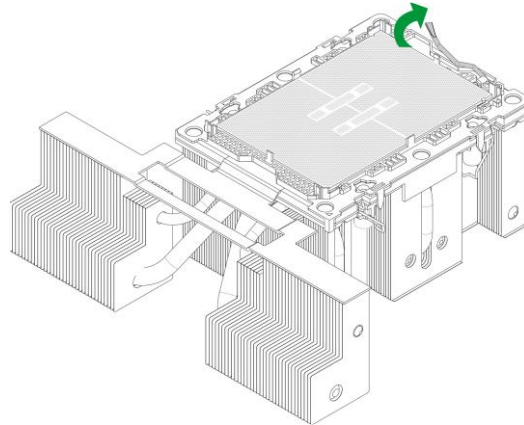

5. To remove the processor, move the lever to its unlocked position and gently remove the processor.

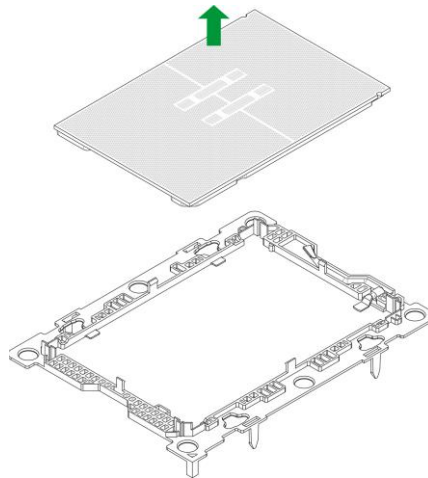

3. Memory

Type and number of fastenings: Two (2) latches per memory module.

Tools required: None.

Procedure: Press both release tabs on the ends of the memory module to unlock it. Once the module is loosened, remove it from the memory slot.

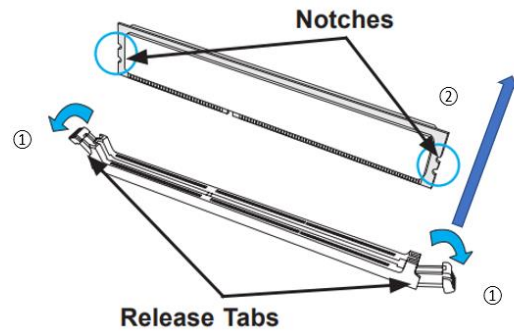

4. Battery

Type and number of fastenings: One (1) latch.

Tools required: None.

Procedure: Push aside the small clamp that covers the edge of the battery. When the battery is released, lift it out of the holder.

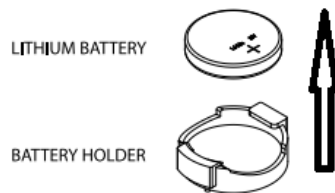

5. M.2 Drive

Type and number of fastenings: One (1) Phillips screw.

Tools required: Screwdriver with PH2 bit.

Procedure:

1. Locate and lift the M.2 tray latch.
2. Unplug the M.2 tray.
3. Unscrew the M.2 drive from the tray.

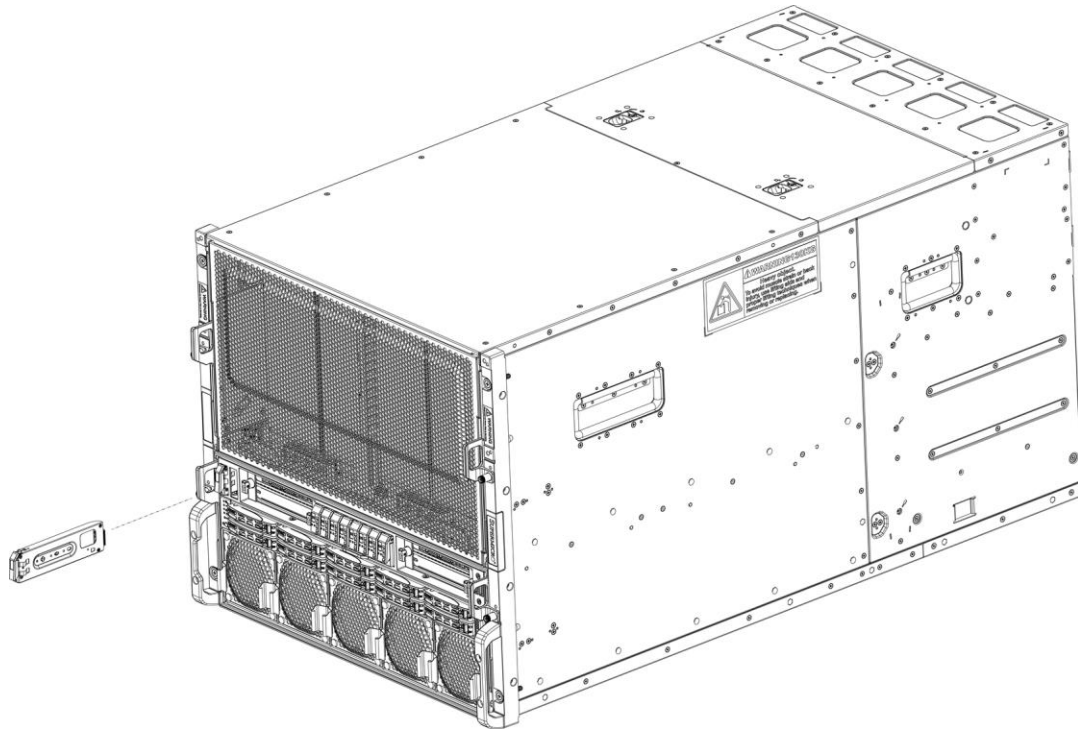

6. 2.5" Drive

Type and number of fastenings: One (1) latch.

Tools required: Flat-head screwdriver (*optional*).

Procedure:

1. Remove the drive carrier from the chassis. Push the release button on the drive carrier. This releases and extends the drive carrier handle.
2. If the button does not release the handle, it may be locked. Using a flat-head screwdriver, rotate the screw counterclockwise 45 degrees to unlock the handle.
3. Use the handle to pull the carrier out of the chassis.
4. Remove the drive from the drive carrier.

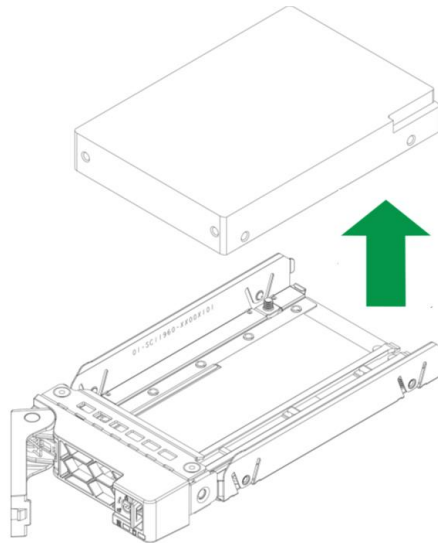
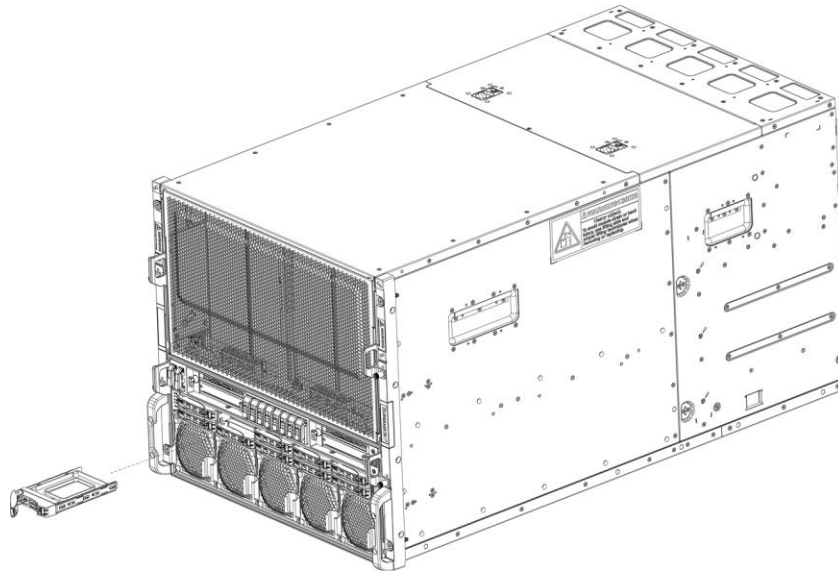

7. Fan

Type and number of fastenings: Two (2) latches.

Tools required: None.

Procedure: Remove the fan from the chassis by squeezing the two release tabs together and pulling the fan out.

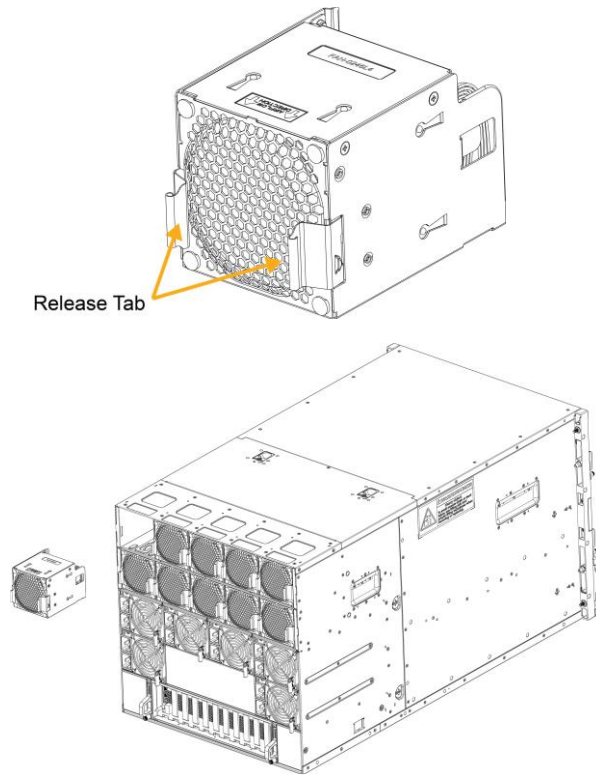

8. Air Shroud

Type and number of fastenings: None.

Tools required: None.

Procedure: Lift the air shroud away from the motherboard.

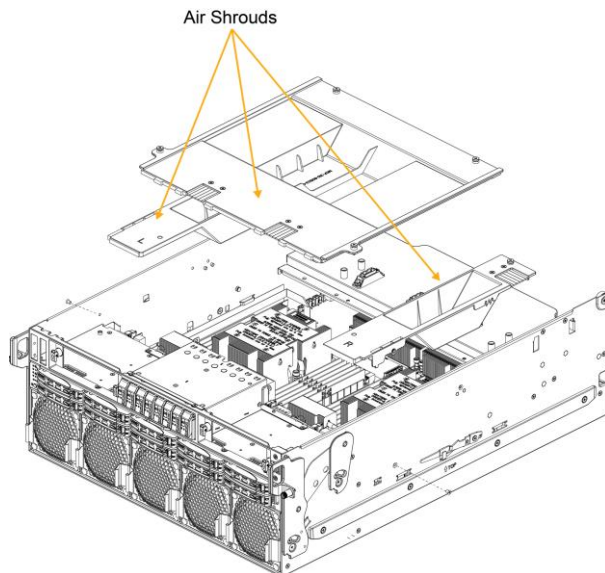

9. LPIO Drawer

Type and number of fastenings: Two (2) Phillips screws.

Tools required: Screwdriver with PH2 bit.

Procedure:

1. Locate the two locking levers on the left and right side of the LPIO drawer. Loosen the screws and pull these levers outward at the same time to unlock the drawer from the chassis.
2. Use these levers to pull the drawer out from the chassis.

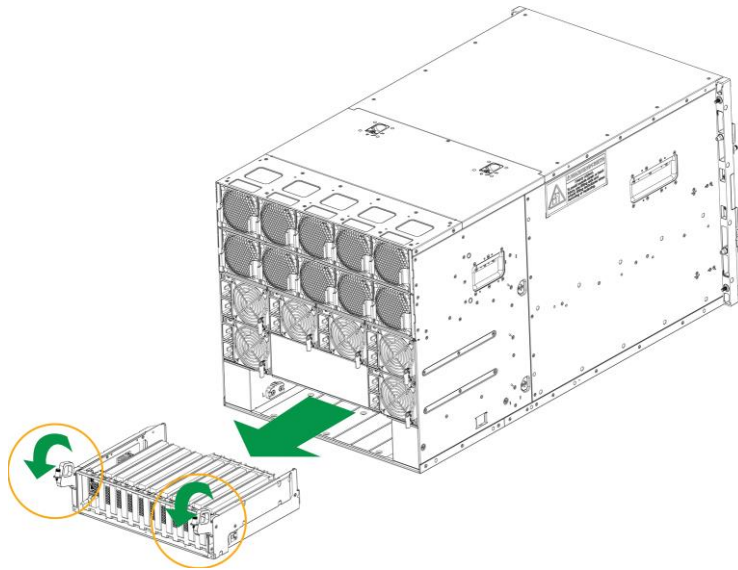

10. Low-Profile PCIe Card

Type and number of fastenings: One (1) Phillips screw.

Tools required: Screwdriver with PH2 bit.

Procedure:

1. After removing the LPIO drawer from the chassis, remove the PCIe card bracket screw.
2. Remove the PCIe card from the slot.

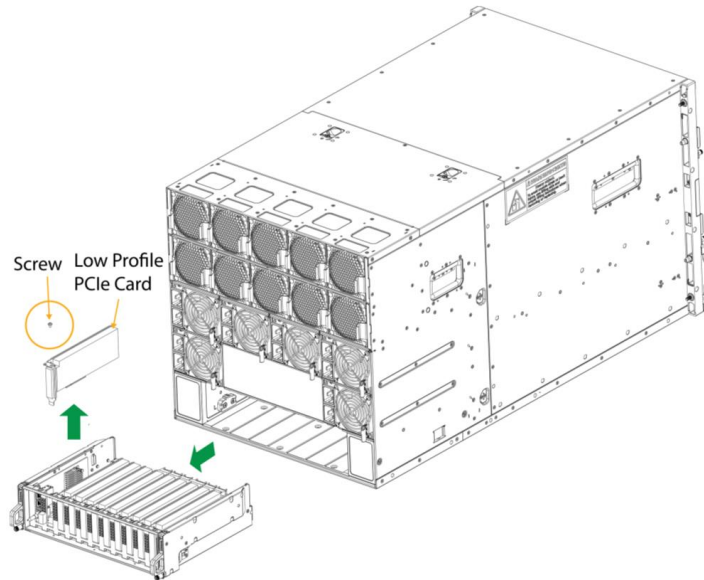

11. CPU Drawer

Type and number of fastenings: Two (2) Phillips screws.

Tools required: Screwdriver with PH2 bit.

Procedure:

11. There are two levers, located directly on the left and right side of the CPU drawer. Loosen the screws and pull these two levers down.
12. Use these levers to pull the drawer out from the chassis.

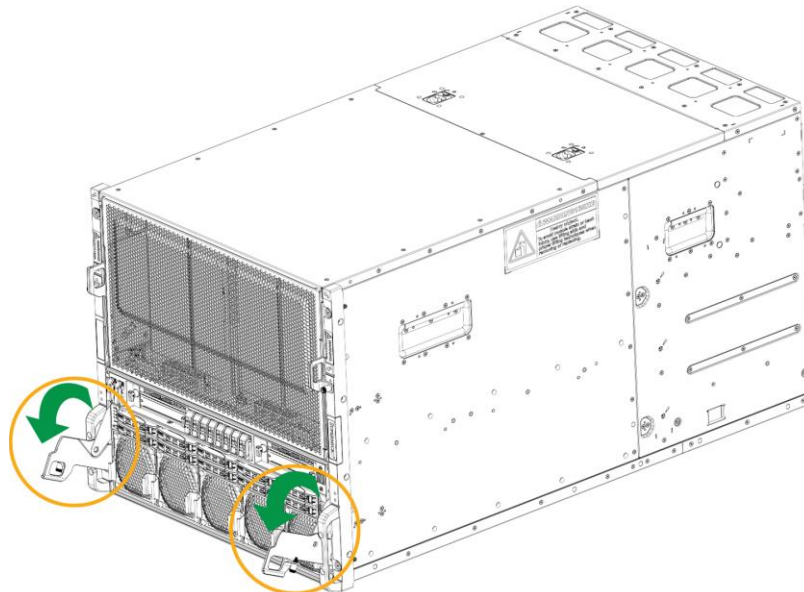

12. CPU Drawer Front Riser Card

Type and number of fastenings: One (1) Phillips screw per riser card.

Tools required: Screwdriver with PH2 bit.

Procedure:

1. Lift the riser card brackets away from the CPU drawer.
2. Remove the screws to separate the riser cards from riser card brackets.

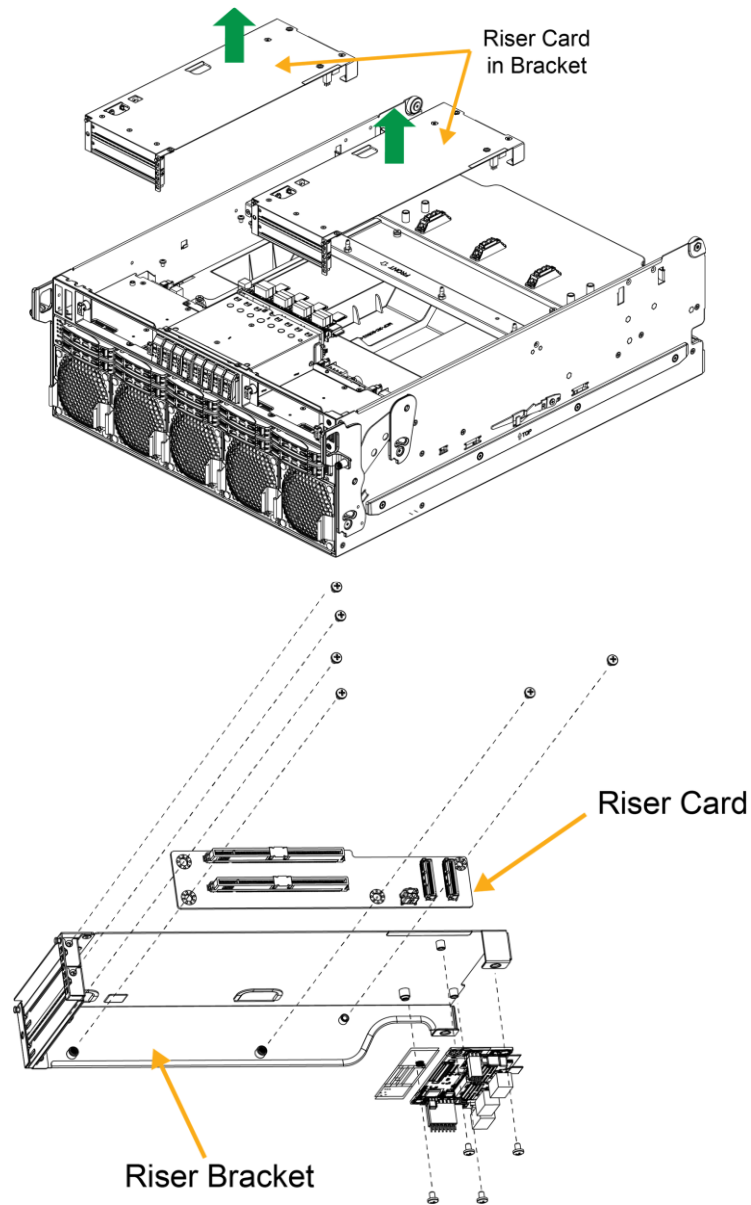

13. Power Supply Module

Type and number of fastenings: One (1) latch per module.

Tools required: None.

Procedure: Unplug the power cord from the power supply. Push the release tab on the back of the power supply module to the side and pull the module straight out.

