

## Information for Lot 9 of ErP (Ecodesign)

This addendum addresses European Union (EU) Ecodesign requirements for servers and storage products. All data and ratings within this addendum are in reference only to the Supermicro product(s) in the manual. The below information conforms to requirements laid down in Annex II of the Commission Regulation 2019/424.

- 3(1)(a): See Section 1.1 of the system manual for the product type.
- 3(1)(b): See the title page and preface of the system manual for the trademark and manufacturer's address.
- 3(1)(c): See the title page of the system manual for product model number(s).
- 3(1)(d): See the serial number on the physical system to determine the year of manufacture.
- 3(1)(e-j): **PSU Efficiency and Power Factor Value (Table) (From 80 Plus report)**

<b>PSU Model#: PWS-407P-1R Watts: 400W</b>	<b>PSU Efficiency</b>				<b>Power Factor</b>
<b>% of Rated Load</b>	<b>10 %</b>	<b>20 %</b>	<b>50 %</b>	<b>100 %</b>	<b>50 %</b>
Single Output (AC-DC)	85.64%	92.05%	94.43%	93.17%	0.98

### **System (EUT) Efficiency in Idle State Power (Table)**

<b>Representative Configurations</b>	<b>Measured Idle State Power (W)</b>	<b>Calculated Idle Power Allowance (W)</b>
High-End Performance Configuration	251.40	358.21
Typical Configuration	N/A	N/A
Low-End Performance Configuration	107.60	229.33

### **System (EUT) Efficiency in Active State Power (Table)**

<b>Representative Configurations</b>	<b>Active State Efficiency Score (Effserver)</b>	<b>Minimum Active State Efficiency for 2-Socket Server</b>
High-End Performance Configuration	18.1	9
Typical Configuration	N/A	
Low-End Performance Configuration	18.7	

3(1)(k): The operating condition class is **A2**.

Operating condition class	Dry bulb temp °C		Humidity range, non-condensing		Max dew point (°C)	Maximum rate of change (°C/hr)
	Allowable range	Recommended range	Allowable range	Recommended range		
A1	15- 32	18-27	- 12 °C Dew Point (DP) and 8 % relative humidity (RH) to 17 °C DP and 80 % RH	- 9 °C DP to 15 °C DP and 60 % RH	17	5/20
A2	10-35	18-27	- 12 °C DP and 8 % RH to 21 °C DP and 80 % RH	Same as A1	21	5/20
A3	5-40	18-27	- 12 °C DP and 8 % RH to 24 °C DP and 85 % RH	Same as A1	24	5/20
A4	5-45	18-27	- 12 °C DP and 8 % RH to 24 °C DP and 90 % RH	Same as A1	24	5/20

3(1)(l): The idle state power at the higher boundary temperature of the operating conditions class is 296.65W.

3(1)(m): The active state efficiency and performance is a minimum of 18.1.

3(1)(n): There are two methods by which a user can securely delete data from this system. The user performing secure data deletion should be an IT professional.

The first is with a Unified Extensible Firmware Interface (UEFI) shell utility. This utility works on X10/X11/H11/H12/M11 motherboard series with onboard SATA/NVMe devices. Any user may access and download this utility through following link:

[https://www.supermicro.com/about/policies/disclaimer.cfm?url=/wftp/utility/Lot9\\_Secure\\_Data\\_Deletion\\_Utility/](https://www.supermicro.com/about/policies/disclaimer.cfm?url=/wftp/utility/Lot9_Secure_Data_Deletion_Utility/)

Download the shell utility package and extract it to a USB flash drive, then plug the drive into the server for which secure data deletion is necessary. Then turn the system on. Navigate to the BIOS setup menu, then place the server system into the UEFI shell environment. Follow the instructions in the README file to invoke the utility and complete the deletion.

The second method is through the secure data deletion tool provided by the original manufacturer of the hard drive. This should be used in a scenario where the shell utility is not applicable. Each manufacturer should have the tool available on their website. If needed, please look on the hard drive label for the name of the manufacturer and model information.

3(1)(o): List of recommended combinations of blade servers with chassis: N/A.

3(1)(p): List of all current SKUs within this product family: N/A.

3(3)(a): There is no use of cobalt in batteries in this product.

The indicative weight range of neodymium in the HDD is 0.0 if manufactured by Western Digital, and is between 5-25 grams if manufactured by Seagate.

3(3)(b): Please see the disassembly instructions on the next page.

# Illustrated System Disassembly Instructions

*Please note: All the illustrations in the below disassembly instructions are for demonstration only. Components shown here may not match exactly with the components in your system.*

**CAUTION: Always power off the system and unplug the power cord(s) first before disassembling the system!**

## 1. Data Storage Devices

*Type and number of fastenings:* Phillips screws (number may vary).

*Tools required:* Screwdriver with PH2 bit.

*Procedure:* Unplug the connected cables. Remove the four Phillips screws that secure the drive tray to the chassis. Then remove the Phillips screws that secure the drive(s) to the drive tray.

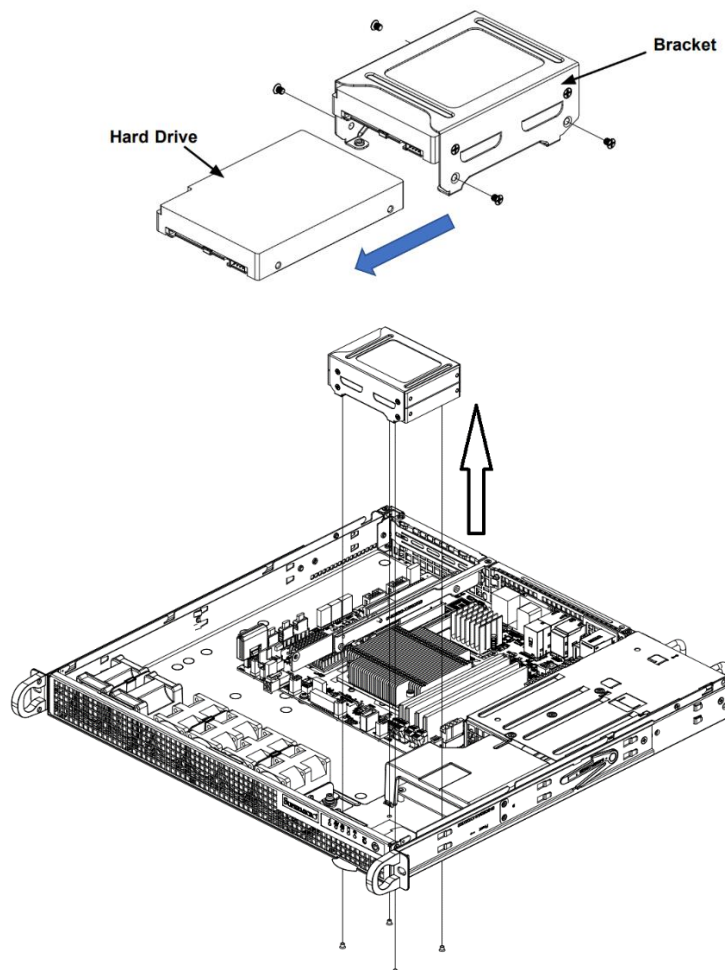

---

## 2. Memory

Type and number of fastenings: Two (2) latches per memory module.

Tools required: None.

Procedure: Press both release tabs on the ends of the memory module to unlock it. Once the module is loosened, remove it from the memory slot.

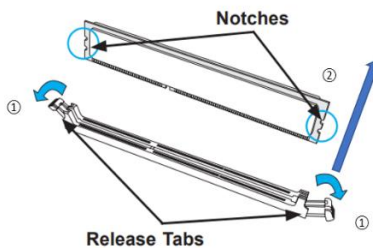

---

## 3. Processor (Socket LGA-2011)

Type and number of fastenings: Four (4) Phillips screws.

Tools required: Screwdriver with PH2 bit.

Procedure: After removing the screws, lift the processor heatsink module off the processor socket. There are two levers on the LGA2011 socket. First press and release the load lever labeled "Open 1<sup>st</sup>." Press the second load lever labeled "Close 1<sup>st</sup>" to release the load plate from its locked position. With the lever labeled "Close 1<sup>st</sup>" fully retracted, gently push down on the "Open 1<sup>st</sup>" lever to open the load plate. Lift the load plate to open it completely. Finally, carefully remove the processor from its socket.

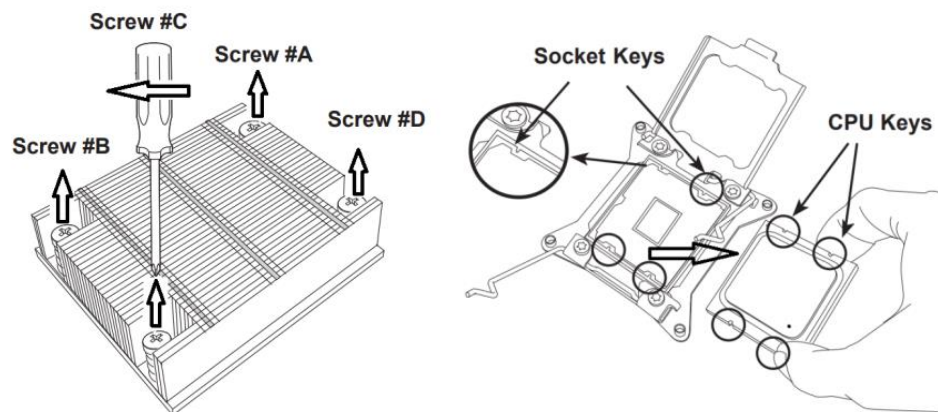

---

## 4. Motherboard

Type and number of fastenings: Phillips screws (number may vary).

Tools required: Screwdriver with PH2 bit.

Procedure: Remove the Phillips screws. Lift the motherboard from its base.

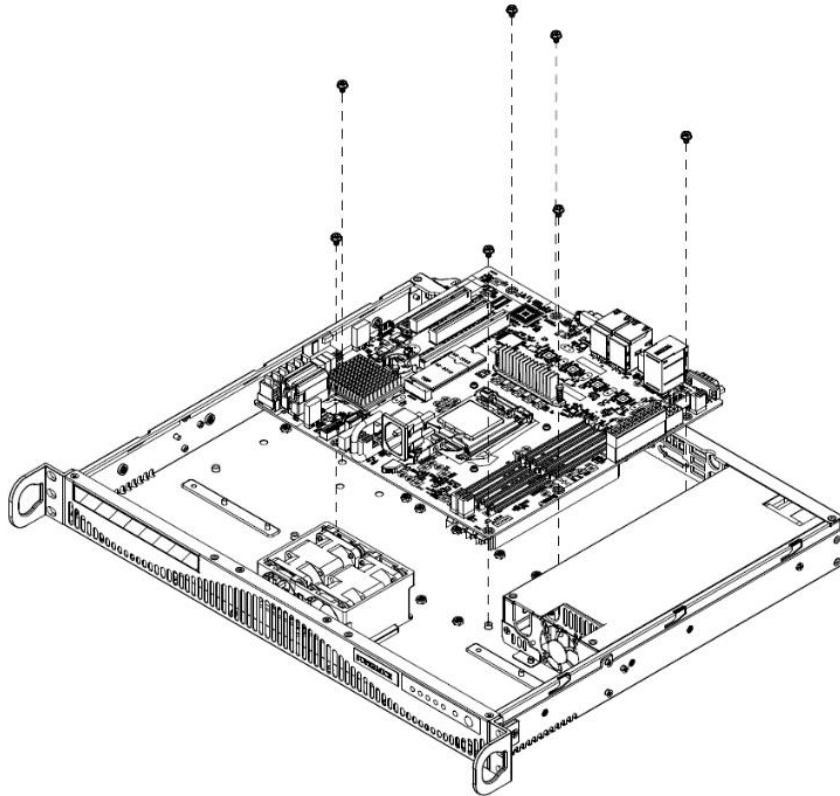

---

## 5. Expansion Card

Type and number of fastenings: Phillips screws (number may vary).

Tools required: Screwdriver with PH2 bit.

Procedure: Remove the riser card bracket from the chassis by unscrewing only the screws indicated by the screwdriver icon as illustrated. Lift the riser card bracket from the chassis. Then open the latch on the end of the bracket. Finally, remove the expansion cards from the riser card.

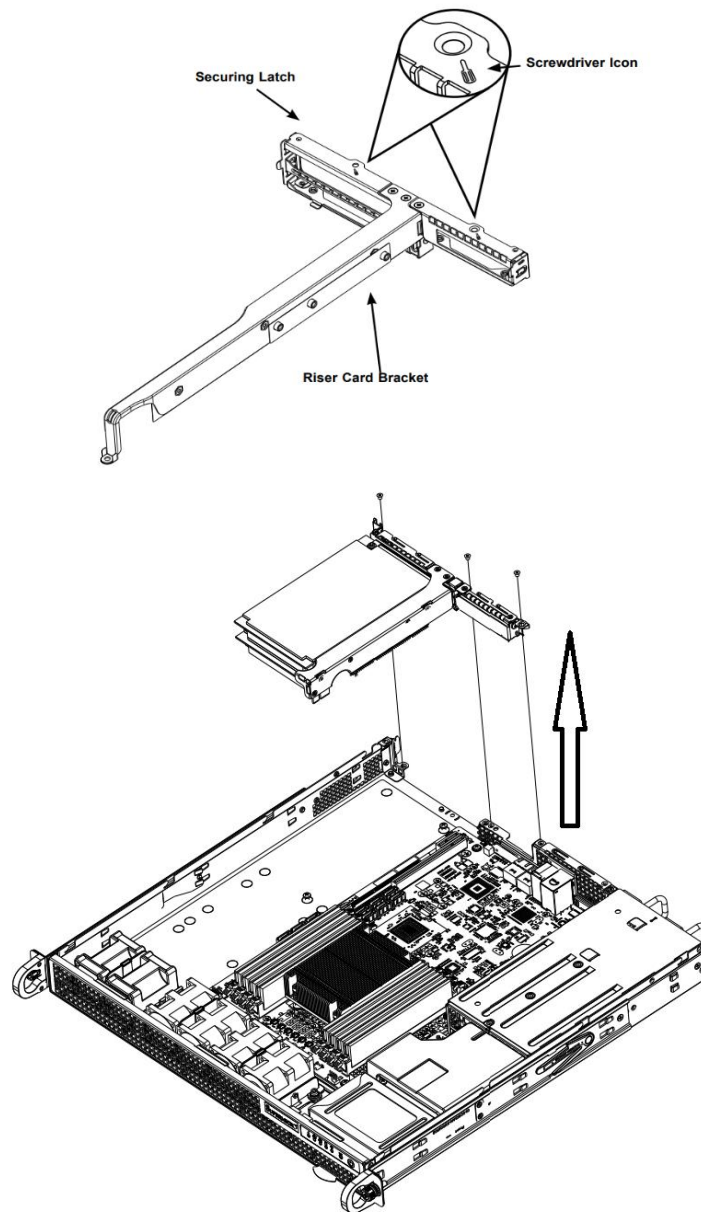

---

## 6. Power Supply Module

*Type and number of fastenings:* One (1) latch per module.

*Tools required:* None.

*Procedure:* Unplug the power cord from the power supply. Push the release tab on the back of the power supply module to the side and pull the module straight out.

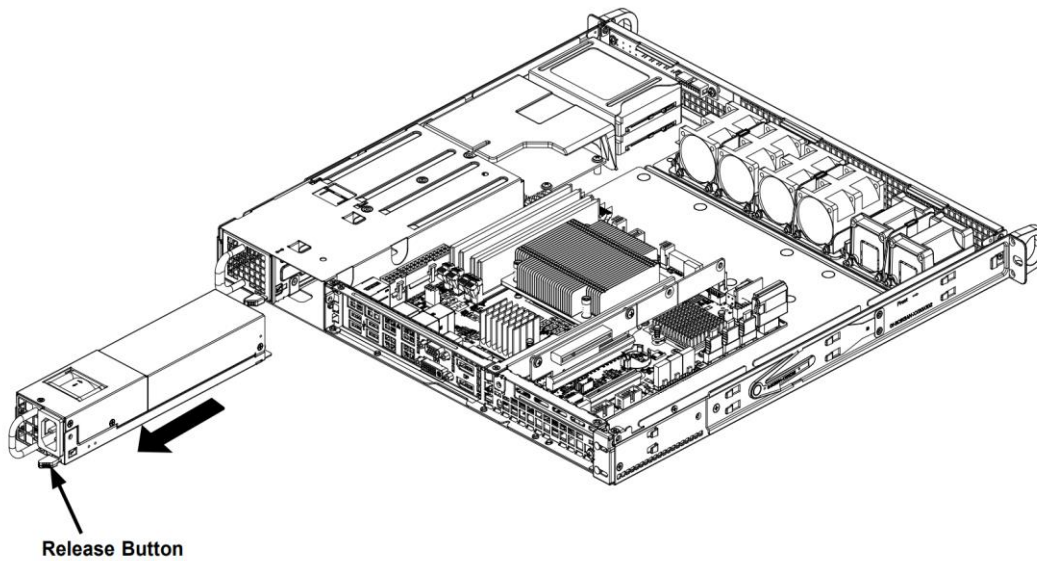

---

## 7. Chassis Cover

Type and number of fastenings: Phillips screws (number may vary).

Tools required: Screwdriver with PH2 bit.

Procedure: Power down the system. Remove the Phillip screws that hold the chassis cover in place. Finally, loosen the thumb screw and lift the cover upward to remove it from the chassis.

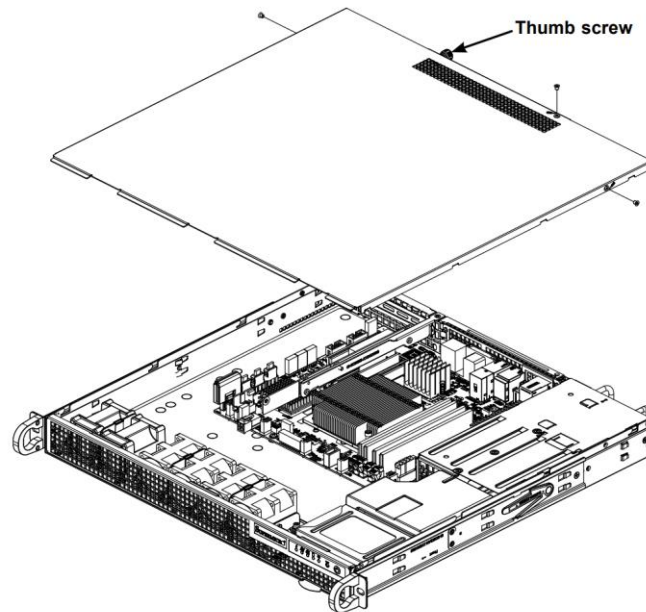

---

## 8. Batteries

Type and number of fastenings: One (1) latch.

Tools required: None.

Procedure: Push aside the small clamp that covers the edge of the battery. When the battery is released, lift it out of the holder.

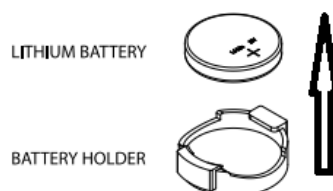

---

## 9. Riser Card

*Type and number of fastenings:* Phillips screws (number may vary).

*Tools required:* Screwdriver with PH2 bit.

*Procedure:* Remove the two screws as indicated and lift the riser card up from the motherboard expansion slot.

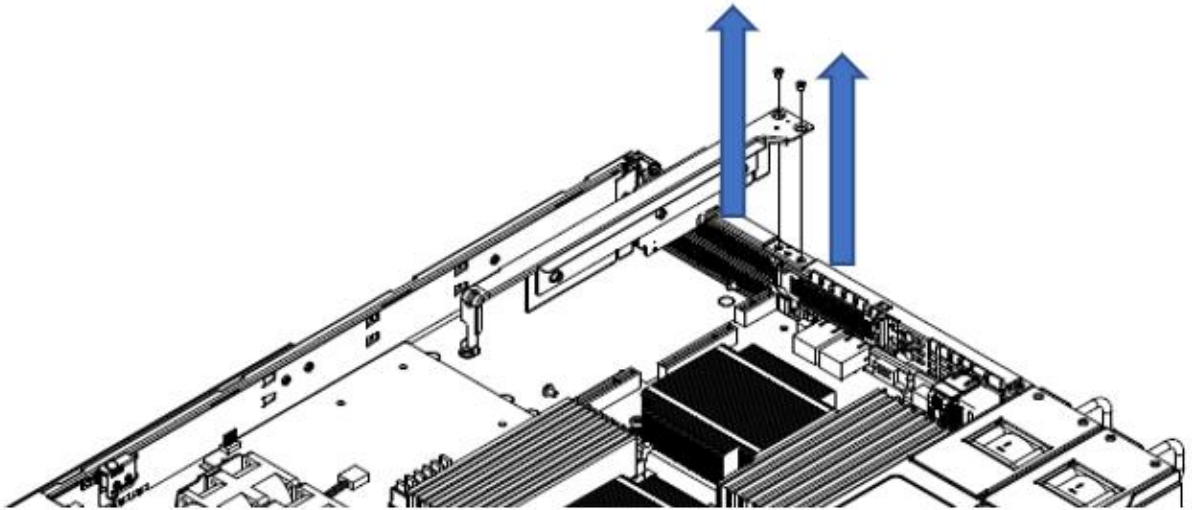

---

## 10. Fans

*Type and number of fastenings:* One (1) fan header per fan.

*Tools required:* None.

*Procedure:* Disconnect the fan wiring from the fan header on the motherboard. Then remove the fan module.

