

SUPERO[®]

SUPERSERVER 6011H

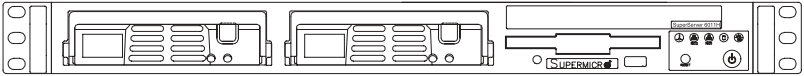

USER'S MANUAL

1.0c

The information in this User's Manual has been carefully reviewed and is believed to be accurate. The vendor assumes no responsibility for any inaccuracies that may be contained in this document, makes no commitment to update or to keep current the information in this manual, or to notify any person or organization of the updates. **Please Note: For the most up-to-date version of this manual, please see our web site at www.supermicro.com.**

SUPERMICRO COMPUTER reserves the right to make changes to the product described in this manual at any time and without notice. This product, including software, if any, and documentation may not, in whole or in part, be copied, photocopied, reproduced, translated or reduced to any medium or machine without prior written consent.

IN NO EVENT WILL SUPERMICRO COMPUTER BE LIABLE FOR DIRECT, INDIRECT, SPECIAL, INCIDENTAL, SPECULATIVE OR CONSEQUENTIAL DAMAGES ARISING FROM THE USE OR INABILITY TO USE THIS PRODUCT OR DOCUMENTATION, EVEN IF ADVISED OF THE POSSIBILITY OF SUCH DAMAGES. IN PARTICULAR, THE VENDOR SHALL NOT HAVE LIABILITY FOR ANY HARDWARE, SOFTWARE, OR DATA STORED OR USED WITH THE PRODUCT, INCLUDING THE COSTS OF REPAIRING, REPLACING, INTEGRATING, INSTALLING OR RECOVERING SUCH HARDWARE, SOFTWARE, OR DATA.

Any disputes arising between manufacturer and customer shall be governed by the laws of Santa Clara County in the State of California, USA. The State of California, County of Santa Clara shall be the exclusive venue for the resolution of any such disputes. Supermicro's total liability for all claims will not exceed the price paid for the hardware product.

Unless you request and receive written permission from SUPER MICRO COMPUTER, you may not copy any part of this document.

Information in this document is subject to change without notice. Other products and companies referred to herein are trademarks or registered trademarks of their respective companies or mark holders.

Copyright © 2003 by SUPER MICRO COMPUTER INC.
All rights reserved.

Printed in the United States of America.

Preface

About This Manual

This manual is written for professional system integrators and PC technicians. It provides information for the installation and use of the SuperServer 6011H. Installation and maintenance should be performed by experienced technicians only.

The SuperServer 6011H is a high-end dual processor 1U rackmount server based on the SC810 1U rackmount server chassis and the P3TDER+, a dual processor motherboard that supports single or dual Intel Pentium® III FCPGA 500 MHz-1.40 GHz processors at front bus speeds of 133 and 100 MHz and up to 4 GB SDRAM main memory.

Manual Organization

Chapter 1: Introduction

The first chapter provides a checklist of the main components included with the server system and describes the main features of the SUPER P3TDER+ mainboard and the SC810 chassis, which make up the SuperServer 6011H.

Chapter 2: Server Installation

This chapter describes the steps necessary to install the SuperServer 6011H into a rack and check out the server configuration prior to powering up the system. If your server was ordered without processor and memory components, this chapter will refer you to the appropriate sections of the manual for their installation.

Chapter 3: System Interface

Refer here for details on the system interface, which includes the functions and information provided by the control panel on the chassis as well as other LEDs located throughout the system.

Chapter 4: System Safety

You should thoroughly familiarize yourself with this chapter for a general overview of safety precautions that should be followed when installing and servicing the SuperServer 6011H.

Chapter 5: Advanced Motherboard Setup

Chapter 5 provides detailed information on the P3TDER+ motherboard, including the locations and functions of connections, headers, jumpers, DIP switches and IRQs. Refer to this chapter when adding or removing processors or main memory and when reconfiguring the motherboard.

Chapter 6: Advanced Chassis Setup

Refer to Chapter 6 for detailed information on the SC810 1U rackmount server chassis. You should follow the procedures given in this chapter when installing, removing or reconfiguring SCSI or peripheral drives and when replacing system power supply units and cooling fans.

Chapter 7: BIOS

The BIOS chapter includes an introduction to BIOS and provides detailed information on running the CMOS Setup Utility.

Appendix A: BIOS Error Beep Codes and Messages

Appendix B: POST Diagnostic Error Codes

Appendix C: System Specifications

Manual Organization

Chp1	Introduction	Overview Chassis Features Mainboard Features Contacting Supermicro	Chp2	Installation	Overview Precautions Rack Installation Setup	Chp3	System Interface	Overview Control Panel Buttons Control Panel LEDs SCSI LEDs Power Supply Switch Motherboard LED	Chp4	System Safety	Electrical Safety General Safety ESD Safety	Chp5	Motherboard Details	Static Safety MB Installation Cables I/O Ports CPU Installation Memory PCI Cards MB Layout Connectors DIP Switches Jumpers Drive Conn. IRQs	Chp6	Chassis Details	Static Safety Control Panel System Fans Drive Bay Inst.	Chp7	BIOS and Setup Routine	Introduction BIOS Features Running CMOS Setup	App. A/B/C	Appendices	BIOS Error Beep Codes Post Diag. Error Messages System Specs
-------------	---------------------	---	-------------	---------------------	---	-------------	-------------------------	--	-------------	----------------------	---	-------------	----------------------------	---	-------------	------------------------	--	-------------	-------------------------------	---	-------------------	-------------------	--

Table of Contents

Preface

About This Manual	iii
Manual Organization	iii
Manual Organization (Chart)	v

Chapter 1: Introduction to the SuperServer 6011H

1-1 Overview	1-1
1-2 Server Chassis Features	1-2
1-3 Mainboard Features	1-4
1-4 Contacting Supermicro	1-6

Chapter 2: Server Installation

2-1 Overview	2-1
2-2 Unpacking the SuperServer 6011H	2-1
2-3 Preparing for Setup	2-1
Choosing a Setup Location	2-2
Rack Precautions	2-2
Server Precautions	2-2
2-4 Installing the SuperServer 6011H into a Rack	2-3
Identifying the Sections of the Rack Rails	2-3
Installing the Chassis Rails	2-4
Installing the Rack Rails	2-4
Installing the Server into the Rack	2-5
Installing the Server into a Telco Rack	2-6
2-5 Checking the Motherboard Setup	2-7
2-6 Checking the Drive Bay Setup	2-9
2-7 Supplying Power to the System	2-10

Chapter 3: System Interface

3-1 Overview	3-1
3-2 Control Panel Buttons	3-1
Reset	3-1
Power	3-1
3-3 Control Panel LEDs	3-2
Overheat	3-2
NIC1/2	3-2
HDD	3-2

Power	3-3
3-4 SCSI Drive Carrier LEDs	3-3
3-5 Power Supply Switch	3-3
3-6 Motherboard LED	3-3

Chapter 4: System Safety

4-1 Electrical Safety Precautions	4-1
4-2 General Safety Precautions	4-2
4-3 ESD Precautions	4-3
4-4 Operating Precautions	4-4

Chapter 5: Advanced Motherboard Setup

5-1 Handling the P3TDER+ Motherboard	5-1
5-2 Motherboard Installation	5-2
5-3 Connecting Cables	5-3
Connecting Data Cables	5-3
Connecting Power Cables	5-3
Connecting the Control Panel	5-4
5-4 I/O Ports	5-5
5-5 Installing Processors	5-5
5-6 Installing Memory	5-8
5-7 Adding PCI Cards	5-9
SUPER P3TDER+ Layout	5-11
SUPER P3TDER+ Quick Reference	5-12
5-8 Connector Definitions	5-13
Power Supply Connector	5-13
Power	5-13
Reset	5-13
Overheat LED	5-14
NIC 1 LED	5-14
NIC 2 LED	5-14
Hard Drive LED	5-14
Power LED	5-15
Chassis Intrusion	5-15
Extra USB Connection	5-15
Fan Headers	5-15
Serial Ports	5-16
ATX PS/2 Keyboard & Mouse Ports	5-16
Universal Serial Bus (USB)	5-16
Wake-On-LAN	5-16

SLED1 (SCSI LED) Indicator	5-17
Power Supply Fail Header	5-17
IPMB	5-17
SMB	5-17
5-9 DIP Switch Settings	5-18
DIP Switch 1: Processor Speed	5-18
5-10 Jumper Settings	5-19
Explanation of Jumpers	5-19
CMOS Clear	5-19
Front Side Bus Speed	5-20
SCSI Termination Enable/Disable	5-20
Watch Dog Enable/Disable	5-20
Speaker Enable/Disable	5-21
Onboard LAN 1 (NIC) Enable/Disable	5-21
Onboard LAN 2 (NIC) Enable/Disable	5-21
Spread Spectrum Enable/Disable	5-21
LVD Channel A SCSI Termination Enable/Disable	5-22
LVD Channel B SCSI Termination Enable/Disable	5-22
Thermal Fan Enable/Disable	5-22
VGA Enable/Disable	5-22
CPU/CPU Chassis Fan Select	5-22
5-11 Floppy/Hard Drive and SCSI Connections	5-23
Floppy Connector	5-23
IDE Connectors	5-24
Ultra160 SCSI Connectors	5-25
5-12 Installing Software Drivers	5-26

Chapter 6: Advanced Chassis Setup

6-1 Static-Sensitive Devices	6-1
6-2 Control Panel	6-2
6-3 System Fans	6-3
System Fan Failure	6-3
Replacing System Cooling Fans	6-3
6-4 Drive Bay Installation/Removal	6-4
Accessing the Drive Bays	6-4
SCSI Drive Installation	6-5
IDE Drive Installation	6-7
CD-ROM and Floppy Drive Installation	6-8
6-5 Power Supply	6-9

Power Supply Failure	6-9
Replacing the Power Supply	6-9

Chapter 7: BIOS

7-1 Introduction	7-1
7-2 BIOS Features	7-2
7-3 Running Setup	7-2
The Main BIOS Setup Menu	7-3
7-4 Advanced BIOS Setup	7-4
7-5 Chipset Setup	7-16
7-6 PCI PnP Setup	7-18
7-7 Power Setup	7-20
7-8 Boot Setup	7-22
7-9 Security Setup	7-24
7-10 Exit Setup	7-26

Appendices:

Appendix A: BIOS Error Beep Codes & Messages	A-1
Appendix B: AMIBIOS POST Diagnostic Error Codes	B-1
Appendix C: System Specifications	C-1

Notes

Chapter 1

Introduction to the SuperServer 6011H

1-1 Overview

The Supermicro SuperServer 6011H is a high-end dual processor, 1U rackmount server that features some of the most advanced technology currently available. The SuperServer 6011H is comprised of two main sub-systems: the SC810 1U rackmount chassis and the P3TDER+, a 370-pin Pentium III Tualatin dual processor mainboard. Please refer to our web site for information on operating systems that have been certified for use with the SuperServer 6011H. (www.supermicro.com)

In addition to the mainboard and chassis, various hardware components may have been included with your SuperServer 6011H, as listed below:

- Up to two (2) 370-pin Pentium III Tualatin processors*
- Two (2) CPU heat sinks* (SNK-023)
- Up to 4 GB ECC registered SDRAM main memory*
- One (1) 1.44" floppy drive
- One (1) slim CD-ROM drive
- One (1) SCA SCSI backplane**
- Two (2) SCA **1-inch high** SCSI drive carriers**
- SCSI Accessories**
 - One (1) internal 68-pin Ultra160 SCSI cable for SCA SCSI backplane
 - One (1) set of SCSI driver diskettes
 - One (1) SCSI manual
- Rackmount hardware (with screws):
 - Two (2) rack rail assemblies
 - Six (6) brackets for mounting the rack rails to a rack/telco rack
- One (1) CD-ROM containing drivers and utilities:
 - Intel LANdesk Client Manager

ATI Rage XL 8MB PCI graphics controller driver
LAN driver
SCSI driver

- SuperServer 6011H User's Manual

** Type and number depends upon the configuration ordered.*

*** SCSI components are not included on the 6011HI model. All information in this manual relating to the SCSI subsystem and SCSI drives do not apply to the 6011HI. For information on installing/removing IDE drives on the 6011HI, refer to Section 6-4.*

1-2 Server Chassis Features

The SuperServer 6011H is a high-end, scaleable 1U rackmount server platform designed with today's most state-of-the-art features. The following is a general outline of the main features of the SC810, a 1U chassis optimized for the use of riser cards.

System Power

When configured as a SuperServer 6011H, the SC810 chassis includes a 250W power supply.

SCSI Subsystem

The SCSI subsystem supports two 80-pin SCA Ultra160 SCSI hard drives. (Any standard 1" drives are supported. SCA = Single Connection Attachment.) The SCSI drives are connected to an SCA backplane that provides power, bus termination and configuration settings. The SCSI drives are also hot-swap units.

Control Panel

The SC810's control panel provides important system monitoring and control information. LEDs indicate power on, network activity, hard disk drive activity and system overheat conditions. The control panel also includes a main power button and a system reset button.

IO Backpanel

The SC810 is a 1U rackmount chassis. Its IO backpanel provides one riser card expansion slot, a VGA (monitor) port, one COM port, two USB ports, PS/2 mouse and keyboard ports and two Ethernet ports. (See Figure 1-1.)

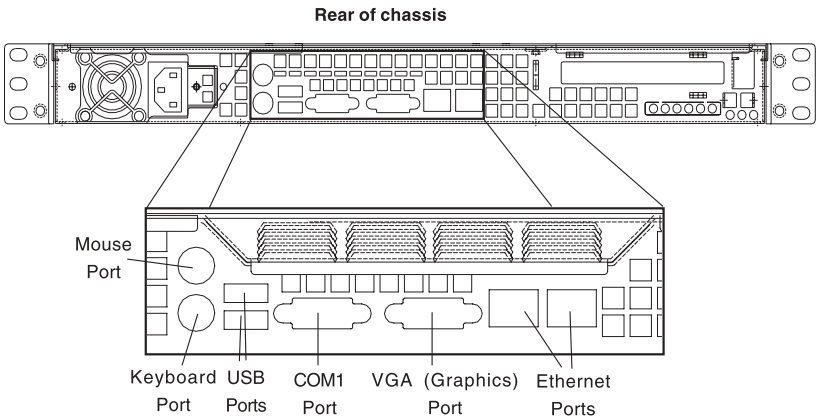

Figure 1-1. IO Backpanel

Cooling System

The SC810 chassis has an innovative cooling design that includes a 10-cm blower system cooling (intake) fan. The blower fan plugs into a chassis fan header on the mother and continuously operates at full rpm. If a fan fails, the ambient air temperature inside the chassis will rise and activate an overheat LED.

1-3 Mainboard Features

At the heart of the SuperServer 6011H lies the P3TDER+, a dual processor motherboard designed to provide high performance. The following are the main features of the P3TDER+.

Chipset

The P3TDER+ is based on ServerWorks ServerSet™ III HE-SL chipset, which is a high-performance core logic chipset that consists of a North Bridge and a South Bridge.

The North Bridge includes an integrated main memory subsystem and a dual channel PCI bus that bridges the processor bus to a 64-bit PCI bus and a 32-bit PCI bus. The North Bridge also packs and unpacks data for PCI accesses, which reserves more processor bandwidth for multiprocessor motherboards.

The South Bridge provides various integrated functions, including the PCI to ISA bridge and support for UDMA33, security (passwords and system protection), Plug & Play, USBs, power management, interrupt controllers and the SMBus.

Processors

The P3TDER+ supports single or dual Pentium III Tualatin 500 MHz-1.40 GHz processors at either a 100 or 133 MHz FSB. Please refer to the support section of our web site for a complete listing of supported processors (<http://www.supermicro.com/TechSupport.htm>).

Memory

The P3TDER+ has 4 DIMM slots that can support up to 4 GB of ECC registered PC133 and PC100 SDRAM. Module sizes of 128MB, 256MB, 512MB and 1 GB may be used to populate the 25 degree DIMM slots.

Onboard SCSI

Onboard SCSI is provided with an Adaptec AIC-7899W SCSI controller chip, which supports dual channel, Ultra160 (320 optional) SCSI at a burst throughput rate of 160 MB/sec. The P3TDER+ provides two SCSI ports.

PCI Expansion Slots

The P3TDER+ has one 64-bit 66/33 MHz PCI slot.

ATI Graphics Controller

The P3TDER+ includes an onboard ATI Rage XL graphics controller. The Rage XL fully supports sideband addressing. This graphics package provides a bandwidth of up to 512 MB/sec over a 32-bit graphics memory bus.

Onboard Controllers/Ports

One floppy drive controller and two onboard IDE controllers support one up to four hard drives or ATAPI devices. Onboard I/O ports include one COM port, two USB ports, PS/2 mouse and keyboard ports, a video (monitor) port and two 10/100 MB Intel 82559 Ethernet (NIC) ports. The P3TDER also includes an onboard ATI Rage XL graphics controller (see above).

Other Features

Other onboard features that promote system health include five voltage monitors, two CPU temperature sensors, four fan speed sensors, a chassis intrusion header, auto-switching voltage regulators, chassis and CPU overheat sensors, virus protection and BIOS rescue.

1-4 Contacting Supermicro

Headquarters

Address: SuperMicro Computer, Inc.
980 Rock Ave.
San Jose, CA 95131 U.S.A.

Tel: +1 (408) 503-8000

Fax: +1 (408) 503-8008

Email: marketing@supermicro.com (General Information)
support@supermicro.com (Technical Support)

Web Site: www.supermicro.com

Europe

Address: SuperMicro Computer B.V.
Het Sterrenbeeld 28, 5215 ML
's-Hertogenbosch, The Netherlands

Tel: +31 (0) 73-6400390

Fax: +31 (0) 73-6416525

Email: sales@supermicro.nl (General Information)
support@supermicro.nl (Technical Support)
rma@supermicro.nl (Customer Support)

Asia-Pacific

Address: SuperMicro, Taiwan
D5, 4F, No. 16 Chien-Ba Road
Chung-Ho 235, Taipei Hsien, Taiwan, R.O.C.

Tel: +886-(2) 8226-3990

Fax: +886-(2) 8226-3991

Web Site: www.supermicro.com.tw

Technical Support:

Email: support@supermicro.com.tw

Tel: 886-2-8228-1366, ext.132 or 139

Chapter 2

Server Installation

2-1 Overview

This chapter provides a quick setup checklist to get your SuperServer 6011H up and running. Following these steps in the order given should enable you to have the system operational in a minimum amount of time. This quick setup assumes that your SuperServer 6011H system has come to you with the processors and memory preinstalled. If your system is not already fully integrated with a motherboard, processors, system memory etc., please turn to the chapter or section noted in each step for details on installing specific components.

2-2 Unpacking the SuperServer 6011H

You should inspect the box the SuperServer 6011H was shipped in and note if it was damaged in any way. If the server itself shows damage you should file a damage claim with the carrier who delivered it.

Decide on a suitable location for the rack unit that will hold the SuperServer 6011H. It should be situated in a clean, dust-free area that is well ventilated. Avoid areas where heat, electrical noise and electromagnetic fields are generated. You will also need it placed near a grounded power outlet. Read the Rack and Server Precautions in the next section.

2-3 Preparing for Setup

The box the SuperServer 6011H was shipped in should include two sets of rail assemblies, two rail mounting brackets and the mounting screws you will need to install the system into the rack. Follow the steps in the order given to complete the installation process in a minimum amount of time. Please read this section in its entirety before you begin the installation procedure outlined in the sections that follow.

Choosing a Setup Location:

- Leave enough clearance in front of the rack to enable you to open the front door completely (~25 inches).
- Leave approximately 30 inches of clearance in the back of the rack to allow for sufficient airflow and ease in servicing.



Warnings and Precautions!



Rack Precautions

- Ensure that the leveling jacks on the bottom of the rack are fully extended to the floor with the full weight of the rack resting on them.
- In single rack installation, stabilizers should be attached to the rack.
- In multiple rack installations, the racks should be coupled together.
- Always make sure the rack is stable before extending a component from the rack.
- You should extend only one component at a time - extending two or more simultaneously may cause the rack to become unstable.

Server Precautions

- Review the electrical and general safety precautions in Chapter 4.
- Determine the placement of each component in the rack *before* you install the rails.
- Install the heaviest server components on the bottom of the rack first, and then work up.
- Use a regulating uninterruptible power supply (UPS) to protect the server from power surges, voltage spikes and to keep your system operating in case of a power failure.
- Allow the hot plug SCSI drives and power supply units to cool before touching them.
- Always keep the rack's front door and all panels and components on the servers closed when not servicing to maintain proper cooling.

2-4 Installing the SuperServer 6011H into a Rack

This section provides information on installing the SuperServer 6011H into a rack unit. If the 6011H has already been mounted into a rack, you can skip ahead to Sections 2-5 and 2-6. There are a variety of rack units on the market, which may mean the assembly procedure will differ slightly. The following is a general guideline for installing the 6011H into a rack with the rack rails provided. You should also refer to the installation instructions that came with the rack unit you are using.

Identifying the Sections of the Rack Rails

You should have received two rack rail assemblies with the SuperServer 6011H. Each of these assemblies consist of two sections: an inner fixed chassis rail that secures to the 6011H (A) and an outer fixed rack rail that secures directly to the rack itself (B). A sliding rail guide sandwiched between the two should remain attached to the fixed rack rail. (See Figure 2-1.) The A and B rails must be detached from each other to install.

To remove the fixed chassis rail (A), pull it out as far as possible - you should hear a "click" sound as a locking tab emerges from inside the rail assembly and locks the inner rail. Then depress the locking tab to pull the inner rail completely out. Do this for both the left and right side rack rail assemblies.

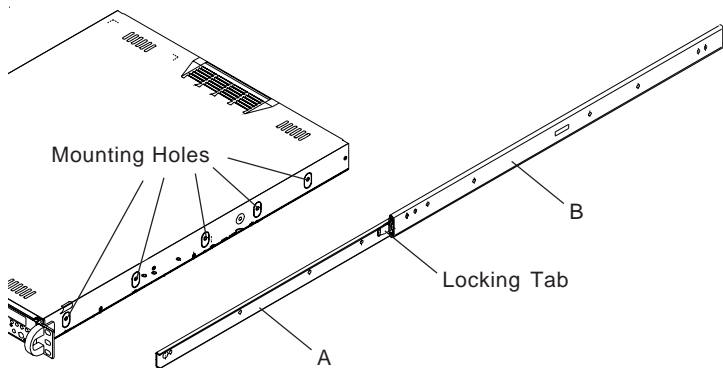

Figure 2-1. Identifying the Sections of the Rack Rails

Installing the Chassis Rails

Position the fixed chassis rail sections you just removed along the side of the 6011H chassis making sure the five screw holes line up. Note that these two rails are left/right specific. Screw the rail securely to the side of the chassis (see Figure 2-2). Repeat this procedure for the other rail on the other side of the chassis. You will also need to attach the rail brackets when installing into a telco rack.

Locking Tabs: As you have seen, both chassis rails have a locking tab, which serves two functions. The first is to lock the server into place when installed and pushed fully into the rack, which is its normal position. Secondly, these tabs also lock the server in place when fully extended from the rack. This prevents the server from coming completely out of the rack when you pull it out for servicing.

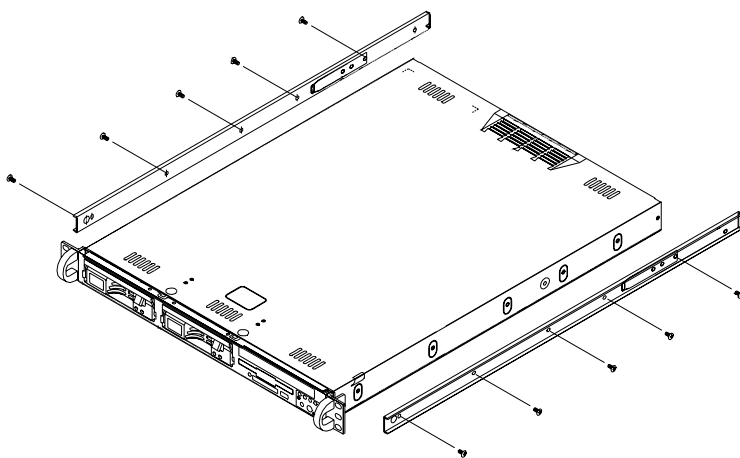

Figure 2-2. Installing Chassis Rails

Installing the Rack Rails

Determine where you want to place the SuperServer 6011H in the rack. (See Rack and Server Precautions in Section 2-3.) Position the fixed rack rail/sliding rail guide assemblies at the desired location in the rack, keeping the sliding rail guide facing the inside of the rack. Screw the assembly securely to the rack using the brackets provided. Attach the other assem-

bly to the other side of the rack, making sure both are at the exact same height and with the rail guides facing inward.

Installing the Server into the Rack

You should now have rails attached to both the chassis and the rack unit. The next step is to install the server into the rack. Do this by lining up the rear of the chassis rails with the front of the rack rails. Slide the chassis rails into the rack rails, keeping the pressure even on both sides (you may have to depress the locking tabs when inserting). See Figure 2-3.

When the server has been pushed completely into the rack, you should hear the locking tabs "click". Finish by inserting and tightening the thumbscrews that hold the front of the server to the rack.

Figure 2-3. Installing the Server into a Rack

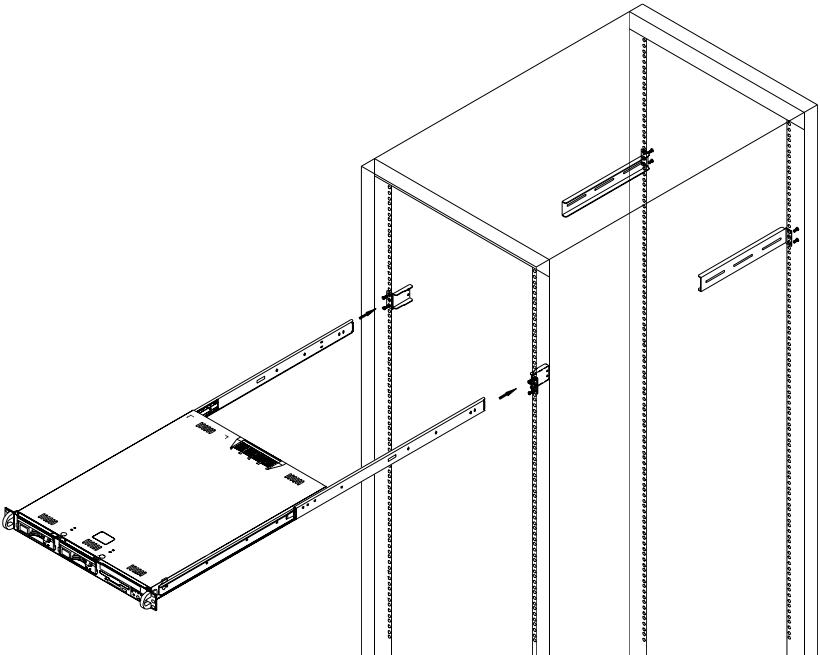

Installing the Server into a Telco Rack

If you are installing the SuperServer 6011H into a Telco type rack, follow the directions given on the previous pages for rack installation. The only difference in the installation procedure will be the positioning of the rack brackets to the rack. They should be spaced apart just enough to accommodate the width of the telco rack.

Figure 2-4. Installing the Server into a Telco Rack

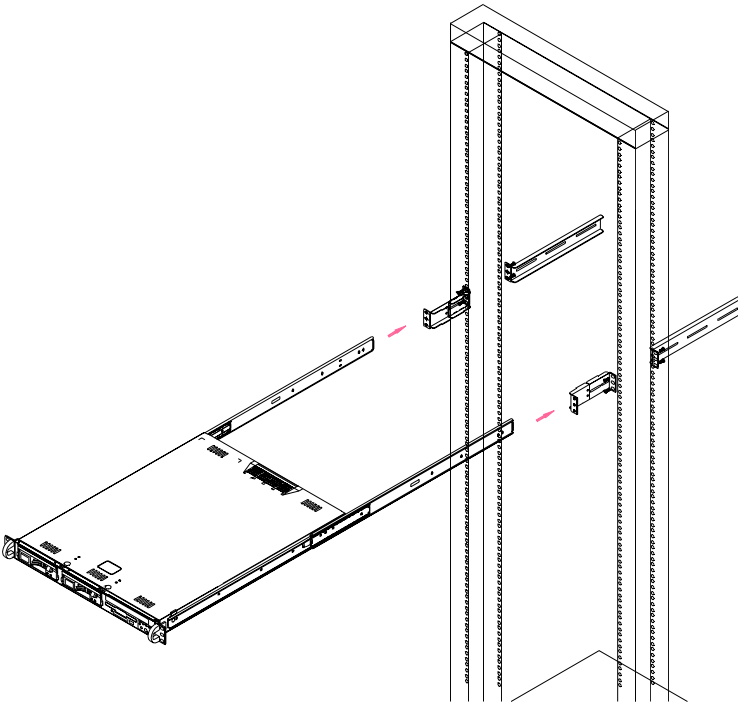

2-5 Checking the Motherboard Setup

After you install the 6011H into the rack, you will need to open the unit to make sure the motherboard is properly installed and all the connections have been made.

1. Access the inside of the 6011H (see Figure 2-5):

First, release the retention screws that secure the unit to the rack. Grasp the two handles on either side and pull the unit straight out until it locks (you will hear a "click"). Next, depress the two buttons on the top of the chassis to release the top cover. There is a large rectangular recess in the middle front of the top cover to help you push the cover away from you until it stops. You can then lift the top cover from the chassis to gain full access to the inside of the server.

2. Check the CPUs (processors):

You should have one or two processors already installed into the system board. Each processor should have its own heatsink attached. See Section 5-5 for instructions on processor installation.

3. Verify the proper CPU speed setting:

You should verify that the CPU speed as set with DIP Switch 1 matches the speed of your installed processors. Most Intel processor speeds will automatically be determined and this step is usually not necessary. However, under certain circumstances you may need to change this setting to reflect the speed of the processors installed in your system. (See Section 5-9 for setting the CPU speed with DIP Switch 1.)

4. Check the system memory:

Your 6011H server system may have come with system memory already installed. Make sure all DIMMs are fully seated in their slots. For details on adding system memory, refer to Section 5-6.

5. Installing add-on cards:

If desired, you can install an add-on card to the system. See Section 5-7 for details on installing a PCI add-on card.

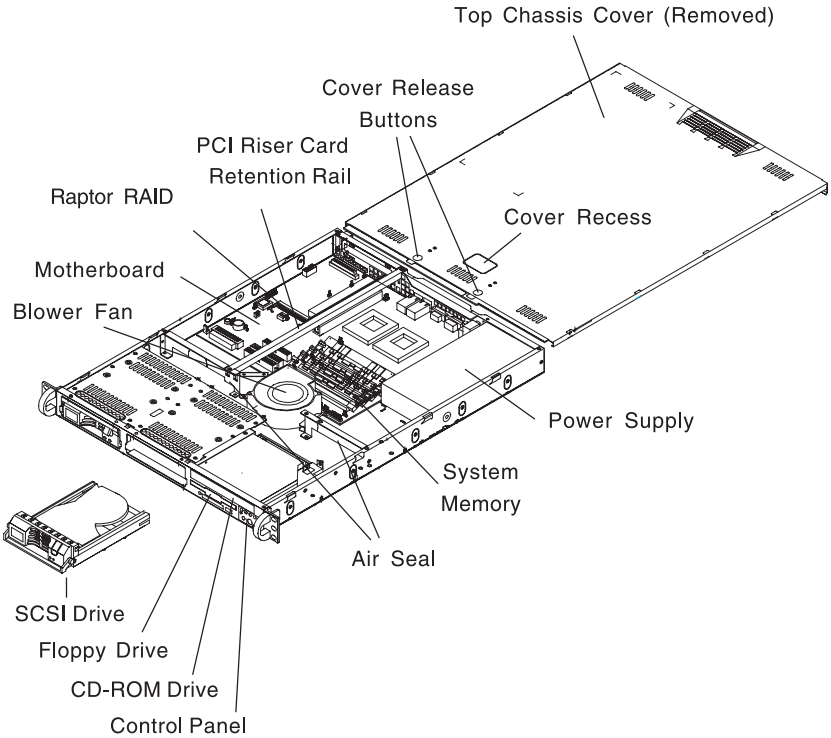

Figure 2-5. Accessing the Inside of the SuperServer 6011H (with one SCSI Drive removed)

6. Check all cable connections and airflow:

Make sure all power and data cables are properly connected and not blocking the airflow. See Section 5-3 for details on cable connections. Also, check the air seals for damage. The air seals are located under the blower fan and beneath the frame cross section that separates the drive bay area from the motherboard area of the chassis.

2-6 Checking the Drive Bay Setup

Next, you should check to make sure the peripheral drives and the SCSI drives and SCA backplane have been properly installed and all connections have been made.

1. Accessing the drive bays:

All drives can be accessed from the front of the server. For servicing the CD-ROM and floppy drives, you will need to remove the top chassis cover. The SCSI disk drives can be installed and removed from the front of the chassis without removing the top chassis cover.

2. Installing a CD-ROM and floppy disk drives:

Refer to Section 6-4 if you need to reinstall a CD-ROM and/or floppy disk drive to the system.

3. Check the SCSI disk drives:

Depending upon your system's configuration, your system may have one drive already installed. If you need to install SCSI drive, please refer to Section 6-4.

4. Check the airflow:

Airflow is provided by a 10-cm blower input fan. The system component layout was carefully designed to promote sufficient airflow through the small 1U rackmount space. Also note that all power and data cables have been routed in such a way that they do not block the airflow generated by the fans.

2-7 Supplying Power to the System

The last thing you must do is to provide input power to the system. Plug the power cord from the power supply unit into a high-quality power strip that offers protection from electrical noise and power surges. It is recommended that you use an uninterruptible power supply (UPS). Finally, push the power on button located on the front control panel to power up the server.

Chapter 3 System Interface

3-1 Overview

There are several LEDs on the control panel as well as others on the SCSI drive carriers and the motherboard to keep you constantly informed of the overall status of the system as well as the activity and health of specific components. There are also two buttons on the chassis control panel and an on/off switch on the power supply. This chapter explains the meanings of all LED indicators and the appropriate response you may need to take.

3-2 Control Panel Buttons

There are two push-button buttons located on the front of the chassis. These are (in order from left to right) a reset button and a power on/off button.

RESET



- **RESET:** The reset switch reboots the system.

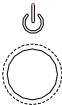

- **POWER:** This is the main power switch, which is used to apply or turn off the main system power. Turning off system power with this button removes the main power but keeps standby power supplied to the system. (See also the power supply on/off switch in Section 3-5.)

3-3 Control Panel LEDs

The control panel located on the front of the SC810 chassis has five LEDs. These LEDs provide you with critical information related to different parts of the system. This section explains what each LED indicates when illuminated and any corrective action you may need to take.



- **Overheat:** Indicates an overheat condition in the chassis. This may be caused by cables obstructing the airflow in the system or the ambient room temperature being too warm. You should also check to make sure that the chassis cover is installed and that all fans are present and operating normally. Finally, check the air seals for damage. The air seals are located under the blower fan and beneath the frame cross section that separates the drive bay area from the motherboard area of the chassis.



NIC2

- **NIC2:** Indicates network activity on LAN2 when flashing.



NIC1

- **NIC1:** Indicates network activity on LAN1 when flashing.



- **HDD:** Indicates IDE channel activity. On the SuperServer 6011H, this light indicates CD-ROM drive activity when flashing.



- **Power:** Indicates power is being supplied to the system's power supply units. This LED should normally be illuminated when the system is operating.

3-4 SCSI Drive Carrier LEDs

A SCSI drive carrier has two LEDs.

- **Green:** When illuminated, the green LED on the front of the SCSI drive carrier indicates drive activity. A connection to the SCSI SCA backplane enables this LED to blink on and off when that particular drive is being accessed.
- **Red:** A SAF-TE compliant backplane is needed to activate the red LED to indicate a drive failure. (A SAF-TE compliant SCSI backplane is optional on the 6011H.) If one of the SCSI drives fail, you should be notified by your system management software. Please refer to Section 6-4 for instructions on replacing failed SCSI drives.

3-5 Power Supply Switch

An on/off switch is located on the back of the power supply. This switch should normally be on at all times. Turning this switch to the off position removes both the main and standby power from the system, as opposed to the power button located on the control panel on the front of the chassis.

3-6 Motherboard LED

There is only one LED on the motherboard. When illuminated, it indicates that system power is present on the motherboard. This LED is located in the corner of the P3TDER+ near the JA1 SCSI connector.

Notes

Chapter 4

System Safety

4-1 Electrical Safety Precautions



Basic electrical safety precautions should be followed to protect yourself from harm and the SuperServer 6011H from damage:

- Be aware of the locations of the power on/off switch on the chassis as well as the room's emergency power-off switch, disconnection switch or electrical outlet. If an electrical accident occurs, you can then quickly remove power from the system.
- Do not work alone when working with high voltage components.
- Power should always be disconnected from the system when removing or installing main system components, such as the motherboard, memory modules and IDE and floppy drives. When disconnecting power, you should first power down the system with the operating system first and then unplug the power cords of all the power supply units in the system.
- When working around exposed electrical circuits, another person who is familiar with the power-off controls should be nearby to switch off the power if necessary.
- Use only one hand when working with powered-on electrical equipment. This is to avoid making a complete circuit, which will cause electrical shock. Use extreme caution when using metal tools, which can easily damage any electrical components or circuit boards they come into contact with.
- Do not use mats designed to decrease static electrical discharge as protection from electrical shock. Instead, use rubber mats that have been specifically designed as electrical insulators.
- The power supply power cords must include a grounding plug and must be plugged into grounded electrical outlets.

- **Motherboard Battery: CAUTION** - There is a danger of explosion if the onboard battery (located near the JA1 SCSI connector) is installed upside down, which will reverse its polarities. This battery must be replaced only with the same or an equivalent type recommended by the manufacturer. Dispose of used batteries according to the manufacturer's instructions.
- **CD-ROM Laser: CAUTION** - this server may have come equipped with a CD-ROM drive. To prevent direct exposure to the laser beam and hazardous radiation exposure, do not open the enclosure or use the unit in any unconventional way.

4-2 General Safety Precautions



Follow these rules to ensure general safety:

- Keep the area around the SuperServer 6011H clean and free of clutter.
- The SuperServer 6011H weighs approximately 54 lbs (24.2 kg) when fully loaded. When lifting the system, two people at either end should lift slowly with their feet spread out to distribute the weight. Always keep your back straight and lift with your legs.
- Place the chassis top cover and any system components that have been removed away from the system or on a table so that they won't accidentally be stepped on.
- While working on the system, do not wear loose clothing such as neckties and unbuttoned shirt sleeves, which can come into contact with electrical circuits or be pulled into a cooling fan.
- Remove any jewelry or metal objects from your body, which are excellent metal conductors that can create short circuits and harm you if they come into contact with printed circuit boards or areas where power is present.
- After accessing the inside of the system, close the system back up and secure it to the rack unit with the retention screws after ensuring that all connections have been made.

4-3 ESD Precautions



Electrostatic discharge (ESD) is generated by two objects with different electrical charges coming into contact with each other. An electrical discharge is created to neutralize this difference, which can damage electronic components and printed circuit boards. The following measures are generally sufficient to neutralize this difference before contact is made to protect your equipment from ESD:

- Use a grounded wrist strap designed to prevent static discharge.
- Keep all components and printed circuit boards (PCBs) in their antistatic bags until ready for use.
- Touch a grounded metal object before removing the board from the antistatic bag.
- Do not let components or PCBs come into contact with your clothing, which may retain a charge even if you are wearing a wrist strap.
- Handle a board by its edges only; do not touch its components, peripheral chips, memory modules or contacts.
- When handling chips or modules, avoid touching their pins.
- Put the motherboard and peripherals back into their antistatic bags when not in use.
- For grounding purposes, make sure your computer chassis provides excellent conductivity between the power supply, the case, the mounting fasteners and the motherboard.

4-3 Operating Precautions



Care must be taken to assure that the chassis cover is in place when the 6011H is operating to assure proper cooling. Out of warranty damage to the 6011H system can occur if this practice is not strictly followed.

Chapter 5

Advanced Motherboard Setup

This chapter covers the steps required to install the P3TDER+ motherboard into the SC810 chassis, connect the data and power cables and install add-on cards. Descriptions of all motherboard jumpers and connections and a motherboard layout and quick reference chart are also included in this chapter. Remember to close the chassis completely when you have finished working with the motherboard to protect and cool the system better.

Tools Required

The only tools you will need to install the P3TDER+ into the SC810 chassis are a long and short Phillips screwdriver.

5-1 Handling the P3TDER+ Motherboard

Static electrical discharge can damage electronic components. To prevent damage to any printed circuit boards (PCBs), it is important to handle them very carefully (see previous chapter). Also note that the size and weight of the motherboard can cause it to bend if handled improperly, which may result in damage. To prevent the motherboard from bending, keep one hand under the center of the board to support it when handling. The following measures are generally sufficient to protect your equipment from static discharge.

Precautions

- Use a grounded wrist strap designed to prevent static discharge.
- Touch a grounded metal object before removing any board from its anti-static bag.
- Handle a board by its edges only; do not touch its components, peripheral chips, memory modules or gold contacts.
- When handling chips or modules, avoid touching their pins.
- Put the motherboard, add-on cards and peripherals back into their anti-static bags when not in use.

Unpacking

The motherboard is shipped in antistatic packaging to avoid static damage. When unpacking the board, make sure the person handling it is static protected.

5-2 Motherboard Installation

This section explains the first step of physically mounting the P3TDER+ into the SC810 chassis. Following the steps in the order given will eliminate the most common problems encountered in such an installation. To remove the motherboard, follow the procedure in reverse order.

1. Accessing the inside of the 6011H (see Figure 2-5):

Two release buttons are located on the top cover of the chassis. Depress both of these buttons while pushing the cover away from you until it stops. You can then lift the top cover from the chassis to gain full access to the inside of the server. (If already installed in a rack, you must first release the retention screws that secure the unit to the rack. Then grasp the two handles on either side and pull the unit straight out until the rails lock into place.)

2. Check the compatibility of the motherboard ports and the chassis backpanel:

The P3TDER+ requires a chassis big enough to support a 12.05" x 11.5" extended ATX motherboard, such as Supermicro's SC810 1U rackmount chassis. Make sure that the I/O ports on the motherboard properly align with their respective holes in the chassis backpanel.

3. Mounting the motherboard onto the motherboard tray:

Carefully mount the motherboard to the motherboard tray by aligning the board holes with the raised metal standoffs that are should be visible on the bottom of the chassis. Insert screws into all the mounting holes on your motherboard that line up with the standoffs and tighten until snug (careful - if you screw them in too tight, you might strip the threads). Metal screws provide an electrical contact to the motherboard ground to provide a continuous ground for the system.

5-3 Connecting Cables

Now that the motherboard is installed, the next step is to connect the cables to the board. These include the data (ribbon) cables for the peripherals and control panel and the power cables.

Connecting Data Cables

The ribbon cables used to transfer data from the peripheral devices have been carefully routed to prevent them from blocking the flow of cooling air that moves through the system from front to back. If you need to disconnect any of these cables, you should take care to keep them routed as they were originally after reconnecting them (make sure the red wires connect to the pin 1 locations). The following data cables (with their locations noted) should be connected. (See the layout in this chapter for connector locations.)

- IDE Device Cables (J13 and J14)
- Floppy Drive Cable (J15)
- Ultra 160 LVD SCSI Connector Channel A (JA1)
- Ultra 160 LVD SCSI Connector Channel B (JA3)
- Control Panel Cable (JF1, see next page)

Connecting Power Cables

The P3TDER+ has a 24-pin primary power supply connector designated "ATX Power" for connection to the ATX power supply. See Section 5-8 for power connector pin definitions.

Connecting the Control Panel

JF1 contains header pins for various front control panel connectors. See Figure 5-1 for the pin locations of the various front control panel buttons and LED indicators. Please note that even and odd numbered pins are on opposite sides of each header.

All JF1 wires have been bundled into single ribbon cable to simplify their connection. Make sure the red wire plugs into pin 1 as marked on the board. The other end connects to the Control Panel printed circuit board, located just behind the system status LEDs in the chassis. The control signals are all on the even numbered pins.

See Section 5-8 for details and pin descriptions of the JF1 connector.

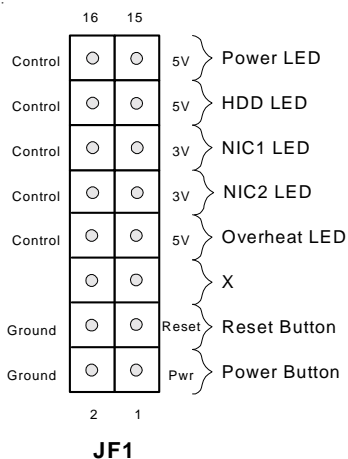

Figure 5-1. P3TDER+ Front Control Panel Header Pins

5-4 I/O Ports

The I/O ports are color coded in conformance with the PC 99 specification. See Figure 5-2 below for the colors and locations of the various I/O ports.

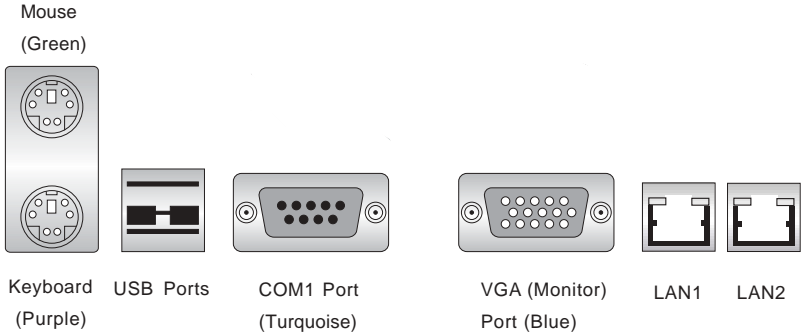

Figure 5-2. P3TDER+ Rear Panel I/O Ports

5-5 Installing Processors



Avoid placing direct pressure to the top of the processor package. Always connect the power cord last and always remove it before adding, removing or changing any hardware components.

1. Installing the FCPGA processors:

The P3TDER+ has two 370-pin sockets to support single or dual Intel Pentium® III FCPGA 500 MHz-1.40 GHz processors with a 512K L2 cache at front bus speeds of 100 and 133 MHz. (You must use the server version of these processors.) Lift the lever on the FCPGA socket and insert the processor keeping the notched corner oriented toward pin one on the socket. Make sure the processor is fully seated in the socket and then close the lever. You can also install a single processor on the motherboard without changing any jumper settings. (Install a single processor into the socket marked "CPU1".) See Figure 5-3 for views of a 370-pin FCPGA socket before and after processor installation.

Figure 5-3. FCPGA Socket: Empty and with Processor Installed**2. Attaching heatsinks to the processors:**

Two passive heatsinks (one for each processor) have been included with your SuperServer 6011H. Secure a heatsink to each processor with a suitable thermal compound to best conduct the heat from the processor to the heatsink. Make sure that you apply the compound evenly and that good contact is made between the CPU chip (the die) and the heatsink. Insufficient contact or improper types of heatsinks and thermal compounds can cause the processor to overheat, which may crash the system. See figure 5-4 for heatsink installation diagrams.

3. Removing the processors:

To remove the processors from the motherboard, simply follow the installation process in reverse order.

Figure 5-4. Heatsink Installation

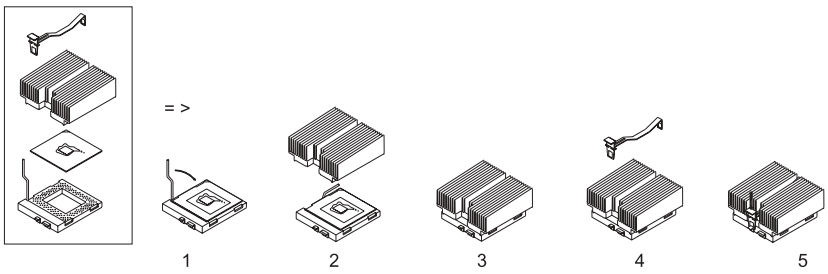

5-6 Installing Memory



CAUTION! Exercise extreme care when installing or removing DIMM modules to prevent any possible damage.

Note: Check the Supermicro web site for recommended memory modules:
http://www.supermicro.com/TECHSUPPORT/FAQs/Memory_vendors.htm

CAUTION

Exercise extreme care when installing or removing DIMM modules to prevent any possible damage. Also note that the memory is interleaved to improve performance (see step 1).

DIMM Installation (See Figure 2-2)

1. Insert either two or four DIMMs as required for the desired system memory. Two-way interleaved memory requires that memory modules be installed in pairs (first in the two slots of Bank0 and then in both slots of Bank1, if needed).
2. Insert each DIMM module vertically into its slot. Pay attention to the two notches along the bottom of the module to prevent inserting the DIMM module incorrectly.
3. Gently press down on the DIMM module until it snaps into place in the slot. Repeat for all modules (see step 1 above).

Support

The P3TDER+ only supports registered ECC SDRAM memory. PC133 and PC100 memory are both supported at their respective speeds. However, the memory bus is synchronized to the front side bus speed, so using PC100 with a 133 MHz FSB or using PC133 with a 100 MHz FSB, will result in 100 MHz memory speed operation in either case.

Figure 5-5. DIMM Installation

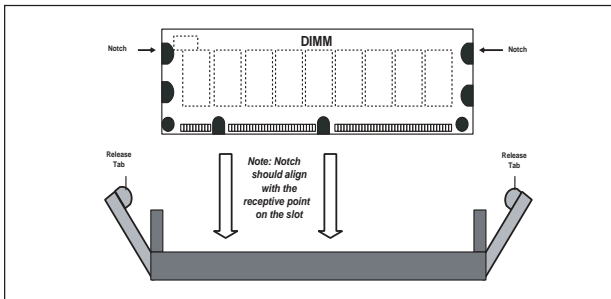

To Install: Insert module vertically and press down until it snaps into place. Pay attention to the bottom notches. **To Remove:** Use your thumbs to gently push each release tab outward to free the DIMM from the slot.

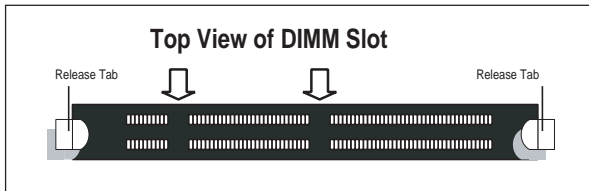

To Remove:
Use your thumbs to gently push each release tab outward. This should release the DIMM from the slot.

5-7 Adding PCI Cards

1. 64-bit PCI slots:

The 6011H system board has one 64-bit, 33/66 MHz PCI slot that requires a **riser card** to fit inside the Supermicro SC810 chassis - see figures 5-6a and 5-6b.

2. 64-bit PCI card installation:

Before installing a PCI add-on card, make sure you choose the correct **riser card** for the type of PCI card you are installing (see step 1, above). Begin by removing the I/O shield for the PCI slot. Insert the PCI card into the PCI slot on the motherboard, pushing down with your thumbs evenly on both sides of the card. Finish by using a screw to secure the top of the card shield to the chassis. The I/O shield protects the motherboard and its components from EMI (electromagnetic interference) and aids in proper ventilation, so make sure there is always a shield covering each slot.

Figure 5-6a. 3.3V and 5V Riser Cards

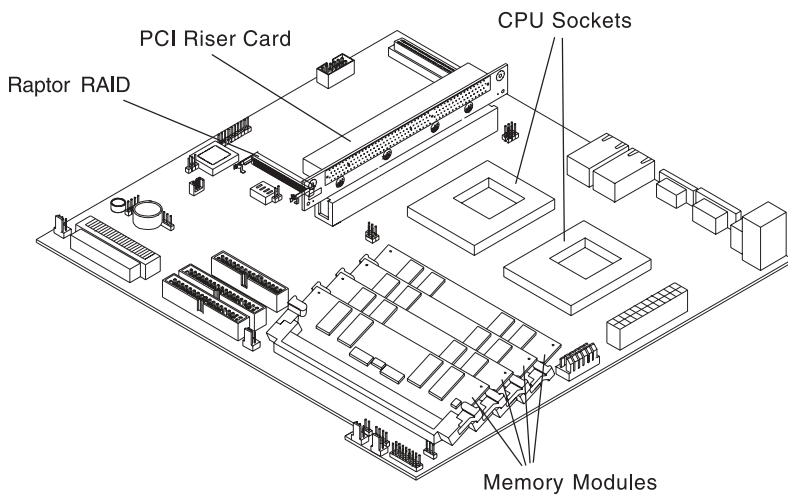
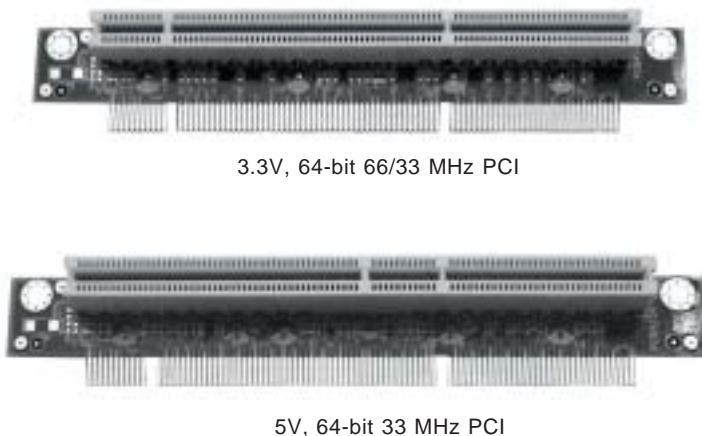
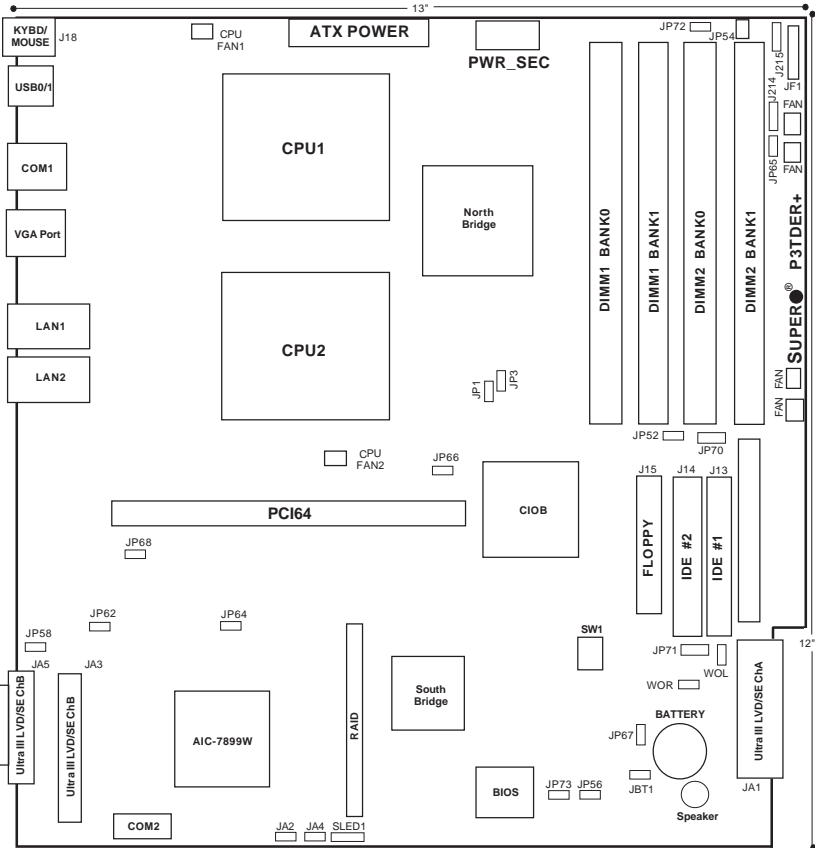

Figure 5-6b. Installing Riser Card

Figure 5-7. SUPER P3TDER+ Layout
(not drawn to scale)



Note: Memory modules must be installed in pairs.
DIP Switch 1 sets the CPU Speed.

Also see Figures 5-1 and 5-2 for the locations of the I/O ports and the Front Control Panel (JF1) connectors, respectively.

P3TDER+ Quick Reference

<u>Jumper</u>	<u>Description</u>	<u>Default Setting</u>
JA2	LVD SCSI Ch A Term.	Open (Enabled)
JA4	LVD SCSI Ch B Term.	Open (Enabled)
JBT1	CMOS Clear	Pins 1-2 (Normal)
JP1	FSB Speed Setting	Pins 1-2 (Auto)
JP3	Spread Spectrum	Open (Disabled)
JP56	Speaker Enable/Disable	Closed (Enabled)
JP58	LAN1 Enable/Disable	Pins 1-2 (Enabled)
JP62	LAN2 Enable/Disable	Pins 1-2 (Enabled)
JP64	SCSI Enable/Disable	Pins 1-2 (Enabled)
JP65	Thermal Fan Enable/Disable	Open (Disabled)
JP68	VGA Enable/Disable	Pins 1-2 (Enabled)
JP72	CPU/CPU Chassis Fan Select	Closed(CPU CH Fan)
JP73	Watch Dog Enable/Disable	Open (Disabled)

<u>Connector</u>	<u>Description</u>
ATX POWER	Primary ATX Power Connector
BANK0/BANK1	Memory (RAM) Slots
COM1/COM2	COM1/2 Serial Port Connector/Header
CPU/CH/OH FAN	CPU/Overheat/Chassis Fan Headers
J13, J14	IDE Hard Disk Drive Connectors
J15	Floppy Disk Drive Connector
J18	PS/2 Keyboard/Mouse
J214	USB3 Header
J215	Power LED Header
JA1	Ultra160 Channel A LVD SCSI
JA3	Ultra160 Channel B LVD SCSI
JF1	Front Control Panel
JP52	Chassis Intrusion Header
JP54	Third Power Supply Fail Header
JP67	NMI (Non-Maskable Interrupt) Connection
JP70	IPMB Connector
JP71	SMB Connector
LAN1/LAN2	Ethernet Port 1 / Ethernet Port 2
PWR_SEC	Secondary ATX Power Connector
RAID	RAID Port Connector
SLED1	SCSI Active LED Header
USB 0/1	Universal Serial Bus Ports
WOL	Wake-on-LAN Header
WOR	Wake-on-Ring Header

5-8 Connector Definitions

Power Supply Connector

After you have mounted the motherboard, added memory, and PCI cards, you are ready to connect the cables. The power supply connector on the P3TDER+ meets the SSI (Superset ATX) 24-pin specification. Make sure that the orientation of the PS connector is correct. Refer to the table on the right for pin definitions.

**ATX Power Supply 24-pin Connector
Pin Definitions (ATX Power)**

Pin Number	Definition	Pin Number	Definition
13	+3.3V	1	+3.3V
14	-12V	2	+3.3V
15	COM	3	COM
16	PS_ON#	4	+5V
17	COM	5	COM
18	COM	6	+5V
19	COM	7	COM
20	Res(NC)	8	PWR_OK
21	+5V	9	5VSB
22	+5V	10	+12V
23	+5V	11	+12V
24	COM	12	+3.3V

Power

The Power Button connection is located on pins 1 and 2 of JF1. Refer to the table on the right for pin definitions.

**Power Button Pin
Definitions (JF1)**

Pin Number	Definition
1	Power
2	Ground

Reset

The Reset Button connection is located on pins 3 and 4 of JF1. This connector attaches to the hardware reset switch on the computer case. Refer to the table on the right for pin definitions.

**Reset Button Pin
Definitions (JF1)**

Pin Number	Definition
3	Reset
4	Ground

Overheat LED

The Overheat LED connection is located on pins 7 and 8 of JF1. It is used to provide advanced warning of chassis overheating. Refer to the table on the right for pin definitions.

**Overheat LED
Pin Definitions
(JF1)**

Pin Number	Definition
7	5V
8	Control

NIC1 LED

The Network Interface Controller 1 LED connection is located on pins 11 and 12 of JF1. This LED displays network activity on LED1. Refer to the table on the right for pin definitions.

**NIC1 LED Pin
Definitions (JF1)**

Pin Number	Definition
11	3V
12	Control

NIC2 LED

The Network Interface Controller 2 LED connection is located on pins 9 and 10 of JF1. This LED displays network activity on LED2. Refer to the table on the right for pin definitions.

**NIC2 LED Pin
Definitions (JF1)**

Pin Number	Definition
9	3V
10	Control

Hard Drive LED

The Hard Drive LED connection is located on pins 13 and 14 of JF1. This LED displays hard disk activity. Refer to the table on the right for pin definitions.

**HDD LED Pin
Definitions (JF1)**

Pin Number	Definition
13	+5V
14	Control

Power LED

The Power LED connection is located on pins 15 and 16 of JF1. It is used to provide indication that power is being supplied to the system. Refer to the table on the right for pin definitions.

**Power LED
Pin Definitions
(JF1)**

Pin Number	Definition
15	5V
16	Control

Chassis Intrusion

A Chassis Intrusion header is located at JP52 on the motherboard. Refer to the table on the right for pin definitions.

**Chassis Intrusion
Pin Definitions (JP52)**

Pin Number	Definition
1	Signal
2	Ground

Extra Universal Serial Bus Connection (USB3)

An additional connection for USB3 is located at J214 on the P3TDER+ for front side USB access. You will need a USB cable (not included) to use this connection. Refer to the table on the right for pin definitions.

**USB3 Pin
Definitions (J214)**

Pin Number	Definition
1	+5V
2	Key
3	IRRX
4	Ground

Fan Headers

The motherboard has CPU, chassis and overheat fan headers designated CPU, CHASSIS and OH FAN, respectively. See the table on the right for pin definitions.

**Fan Header Pin Definitions
(CPU/CHASSIS/OH Fans)**

Pin Number	Definition
1	Ground (black)
2	+12V (red)
3	Tachometer

Caution: These fan headers are DC power.

Serial Ports

On the P3TDER+, COM1 is located beside the USB ports on the backplane (see Figure 5-2) and COM2 is a header located near the Ultra160 SCSI channel B header (JA3) on the motherboard. See the table on the right for pin definitions.

**Serial Port Pin Definitions
(COM1, COM2)**

Pin Number	Definition	Pin Number	Definition
1	CD	6	DSR
2	RD	7	RTS
3	TD	8	CTS
4	DTR	9	RI
5	Ground	10	NC

Note: Pin 10 is included on the header but not on the port.

ATX PS/2 Keyboard and PS/2 Mouse Ports

The ATX PS/2 keyboard and the PS/2 mouse are located on the backplane at J18. See the table on the right for pin definitions. (The mouse port is above the keyboard port. See Figure 5-2.)

**PS/2 Keyboard and Mouse Port
Pin Definitions
(J18)**

Pin Number	Definition
1	Data
2	NC
3	Ground
4	VCC
5	Clock
6	NC

Universal Serial Bus (USB)

Two Universal Serial Bus ports are located on the backplane beside the keyboard/mouse ports. USB0 is the bottom connector and USB1 is the top connector. See the table on the right for pin definitions.

**Universal Serial Bus Pin Definitions
USB0 USB1**

USB0		USB1	
Pin Number	Definition	Pin Number	Definition
1	+5V	1	+5V
2	P0-	2	P0-
3	P0+	3	P0+
4	Ground	4	Ground
5	N/A	5	Key

Wake-On-LAN

The Wake-On-LAN header is designated as WOL. See the table on the right for pin definitions. You must enable the LAN Wake-Up setting in BIOS to use this feature. You must also have a LAN card with a Wake-on-LAN connector and cable.

**Wake-On-LAN Pin
Definitions (WOL)**

Pin Number	Definition
1	+5V Standby
2	Ground
3	Wake-up

SLED1 (SCSI LED) Indicator

The SLED connector is used to provide an LED indication of SCSI activity. See the table on the right for pin definitions.

**SCSI LED Pin Definitions
(SLED1)**

Pin Number	Definition
1	Positive
2	Negative
3	Negative
4	Positive

Power Supply Fail Header

Connect a cable from your power supply to the header labelled JP54 to provide warning of power supply failure. This warning signal is passed through the PWR_LED pin on JF1 to provide indication of a power failure on the chassis. This feature is only available when using Supermicro power supplies. See the table on the right for pin definitions.

**Power Supply Fail Header
Pin Definitions (JP54)**

Pin Number	Definition
1	P/S 1 Fail Signal
2	P/S 2 Fail Signal
3	P/S 3 Fail Signal
4	Reset (from MB)

IPMB

An IPMB (Intelligent Platform Management Bus) connection is located at JP70. Connect the appropriate cable here to utilize IPMI on your system.

SMB

An SMB (System Management Bus) connection is located at JP71. Connect the appropriate cable here to utilize SMB on your system.

5-9 DIP Switch Settings

DIP Switch 1: CPU Speed

The red "DIP" switch labeled SW1 has four individual switches, which are used to set the speed of the CPU (processor). The table on the right shows the switch settings for the various speeds your processor may be able to run at. The speeds on the left are for 100 MHz and those on the right are for 133 MHz front side bus processors.

CPU Speed	SW #4	SW #3	SW #2	SW #1
500/666	ON			ON
550/733	ON			
600/800		ON	ON	ON
650/866		ON	ON	
700/933		ON		ON
750/1GHz		ON		
800/1.064			ON	ON
850/1.13	ON	ON		ON
900/1.20	ON	ON		
950/1.26	ON	ON	ON	
1.00/1.33			ON	
1.05/1.40	ON			ON

Note: Most Intel processors have a fixed Core/Bus ratio that overwrites the setting of DIP Switch 1.

5-10 Jumper Settings

Explanation of Jumpers

To modify the operation of the motherboard, jumpers can be used to choose between optional settings. Jumpers create shorts between two pins to change the function of the connector. Pin 1 is identified with a square solder pad on the printed circuit board. See the motherboard layout pages for jumper locations.

Note: On two pin jumpers, "Closed" means the jumper is on both pins and "Open" means the jumper is off the pins.

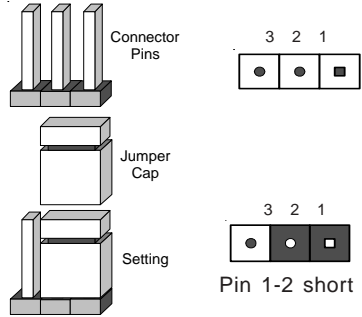

CMOS Clear

Refer to the table on the right for the jumper settings to clear CMOS. Always remove the AC power cord from the system before clearing CMOS. **Note:** For an ATX power supply, you must completely shut down the system, remove the AC power cord and *then* use JBT1 to clear CMOS. Replace JBT1 back to the pin 1-2 position before powering up the system again. Do not use the PW_ON connector to clear CMOS.

CMOS Clear Jumper Settings (JBT1)

Jumper Position	Definition
1-2	Normal
2-3	CMOS Clear

The diagram shows two vertical pins labeled 'Position 1-2' and 'Position 2-3'. The 'Normal' setting shows a jumper cap covering pins 1 and 2. The 'CMOS Clear' setting shows a jumper cap covering pins 2 and 3.

Front Side Bus Speed

CPU speed = FSB x Core/Bus ratio

The FSB Speed is set with JP1 on the P3TDER+ (see the table on the right). See the previous section for the CPU Speed setting (setting the CPU speed is usually not necessary).

**Front Side Bus Speed
Jumper Settings (JP1)**

Jumper Position	Definition
1-2	Auto
2-3	100 MHz
OFF	133 MHz

Note: The Auto setting allows the CPU to set the speed.

SCSI Termination Enable/ Disable

The SCSI Termination jumper JP64 allows you to enable or disable termination for the SCSI connectors. The normal (default) position is open to enable SCSI termination. See the table on the right for jumper settings.

**SCSI Termination
Enable/Disable
Jumper Settings
(JP64)**

Jumper Position	Definition
Open	Enabled
Closed	Disabled

Watch Dog Enable/Disable

JP73 allows you to enable or disable the Watch Dog feature. The normal (default) position is open to disable the Watch Dog timer and enable the speaker. This jumper setting works in conjunction with the setting in BIOS. See the table on the right for jumper settings.

**Watch Dog
Enable/Disable
Jumper Settings
(JP73)**

Jumper Position	Definition
Open	Disabled
Closed	Enabled

Speaker Enable/Disable

You may want to disable the onboard speaker. Jumper JP56 gives you this option. See the table on the right for jumper settings.

**Speaker Enable/Disable
Jumper Settings (JP56)**

Jumper Position	Definition
Open	Disabled
Closed	Enabled

Onboard LAN1 (NIC) Enable/Disable

Change the setting of jumper JP58 to enable or disable the onboard LAN1 (or Network Interface Card) on your motherboard. See the table on the right for jumper settings.

**Onboard LAN1 (NIC)
Enable/Disable
Jumper Settings (JP58)**

Jumper Position	Definition
Pins 1-2	Enabled
Pins 2-3	Disabled

Onboard LAN2 (NIC) Enable/Disable

Change the setting of jumper JP62 to enable or disable the onboard LAN1 (or Network Interface Card) on your motherboard. See the table on the right for jumper settings.

**Onboard LAN2 (NIC)
Enable/Disable
Jumper Settings (JP62)**

Jumper Position	Definition
Pins 1-2	Enabled
Pins 2-3	Disabled

Spread Spectrum Enable/ Disable

Jumper JP3 is used to enable or disable the Spread Spectrum feature. Spread Spectrum is a technique used to stabilize operation when a system is being affected by electromagnetic interference. The normal (default) position is open to disable Spread Spectrum. See the table on the right for jumper settings.

**Spread Spectrum
Jumper Settings (JP3)**

Jumper Position	Definition
Open	Disabled
Closed	Enabled

LVD Channel A SCSI Termination Enable/Disable

Jumper JA2 allows you to enable or disable termination for the LVD Channel A SCSI connector. The normal (default) position is open to enable SCSI termination. See the table on the right for jumper settings.

LVD CH A SCSI Termination Jumper Settings (JA2)

Jumper Position	Definition
Open	Enabled
Closed	Disabled

LVD Channel B SCSI Termination Enable/Disable

Jumper JA4 allows you to enable or disable termination for the LVD Channel B SCSI connector. The normal (default) position is open to enable SCSI termination. See the table on the right for jumper settings.

LVD CH B SCSI Termination Jumper Settings (JA4)

Jumper Position	Definition
Open	Enabled
Closed	Disabled

Thermal Fan Enable/Disable

JP65 allows you to enable or disable continuous operation of the thermal fan. The default position is open to disable continuous operation. See the table on the right for jumper settings.

Thermal Fan Enable/Disable Jumper Settings (JP65)

Jumper Position	Definition
Open	Disabled
Closed	Enabled

VGA Enable/Disable

JP68 allows you to enable or disable the VGA port. The default position is on pins 1 and 2 to enable VGA. See the table on the right for jumper settings.

VGA Enable/Disable Jumper Settings (JP68)

Jumper Position	Definition
1-2	Enabled
2-3	Disabled

CPU/CPU Chassis Fan Select

JP72 allows you to select to use either the CPU fan or the CPU Chassis fan. The default position is closed to select the CPU fan. See the table on the right for jumper settings.

CPU/CPU Chassis Fan Select Jumper Settings (JP72)

Jumper Position	Definition
Open	CPU Chassis
Closed	CPU

5-11 Floppy/Hard Drive and SCSI Connections

Note the following when connecting the floppy and hard disk drive cables:

- The floppy disk drive cable has seven twisted wires.
- A red mark on a wire typically designates the location of pin 1.
- A single floppy disk drive ribbon cable has 34 wires and two connectors to provide for two floppy disk drives. The connector with twisted wires always connects to drive A, and the connector that does not have twisted wires always connects to drive B.

Floppy Connector

The floppy connector is located on J15. See the table below for pin definitions.

Floppy Connector Pin Definitions (JP15)

Pin Number	Function	Pin Number	Function
1	GND	2	FDHDIN
3	GND	4	Reserved
5	Key	6	FDEDIN
7	GND	8	Index-
9	GND	10	Motor Enable
11	GND	12	Drive Select B-
13	GND	14	Drive Select A-
15	GND	16	Motor Enable
17	GND	18	DIR-
19	GND	20	STEP-
21	GND	22	Write Data-
23	GND	24	Write Gate-
25	GND	26	Track 00-
27	GND	28	Write Protect-
29	GND	30	Read Data-
31	GND	32	Side 1 Select-
33	GND	34	Diskette

IDE Connectors

There are no jumpers to configure the onboard IDE connectors J13 and J14. See the table below for pin definitions.

**IDE Connector Pin Definitions
(J13, J14)**

Pin Number	Function	Pin Number	Function
1	Reset IDE	2	GND
3	Host Data 7	4	Host Data 8
5	Host Data 6	6	Host Data 9
7	Host Data 5	8	Host Data 10
9	Host Data 4	10	Host Data 11
11	Host Data 3	12	Host Data 12
13	Host Data 2	14	Host Data 13
15	Host Data 1	16	Host Data 14
17	Host Data 0	18	Host Data 15
19	GND	20	Key
21	DRQ3	22	GND
23	I/O Write-	24	GND
25	I/O Read-	26	GND
27	IOCHRDY	28	BALE
29	DACK3-	30	GND
31	IRQ14	32	IOCS16-
33	Addr 1	34	GND
35	Addr 0	36	Addr 2
37	Chip Select 0	38	Chip Select 1-
39	Activity	40	GND

Ultra160 SCSI Connectors

See the table below for pin definitions for the Ultra160 SCSI connectors located at JA1, JA3 and JA5.

68-pin Ultra160 SCSI Connectors (JA1, JA3, JA5)

Connector Contact Number	Signal Names	Connector Contact Number	Signal Names
1	+DB(12)	35	-DB(12)
2	+DB(13)	36	-DB(13)
3	+DB(14)	37	-DB(14)
4	+DB(15)	38	-DB(15)
5	+DB(P1)	39	-DB(P1)
6	+DB(0)	40	-DB(0)
7	+DB(1)	41	-DB(1)
8	+DB(2)	42	-DB(2)
9	+DB(3)	43	-DB(3)
10	+DB(4)	44	-DB(4)
11	+DB(5)	45	-DB(5)
12	+DB(6)	46	-DB(6)
13	+DB(7)	47	-DB(7)
14	+DB(P)	48	-DB(P)
15	GROUND	49	GROUND
16	DIFFSENS	50	GROUND
17	TERMPWR	51	TERMPWR
18	TERMPWR	52	TERMPWR
19	RESERVED	53	RESERVED
20	GROUND	54	GROUND
21	+ATN	55	-ATN
22	GROUND	56	GROUND
23	+BSY	57	-BSY
24	+ACK	58	-ACK
25	+RST	59	-RST
26	+MSG	60	-MSG
27	+SEL	61	-SEL
28	+C/D	62	-C/D
29	+REQ	63	-REQ
30	+I/O	64	-I/O
31	+DB(8)	65	-DB(8)
32	+DB(9)	66	-DB(9)
33	+DB(10)	67	-DB(10)
34	+DB(11)	68	-DB(11)

5-12 Installing Software Drivers

After all the hardware has been installed you must install the software drivers. The necessary drivers are all included on the Supermicro CD that came packaged with your motherboard. After inserting this CD into your CD-ROM drive, the display shown in Figure 5-8 should appear. (If this display does not appear, click on the My Computer icon and then on the icon representing your CD-ROM drive. Finally, double click on the S "Setup" icon.)



Figure 5-8 Driver/Tool Installation Display Screen

Click the icons showing a hand writing on paper to view the readme files for each item. The CD icon at the bottom it allows you to view the entire contents of the CD.

Build SCA disk (QLogic GEM 354): For integration with the SuperServer SC850 and SC860 chassis.

Chapter 6

Advanced Chassis Setup

This chapter covers the steps required to install components and perform maintenance on the SC810 chassis. For component installation, follow the steps in the order given to eliminate the most common problems encountered. If some steps are unnecessary, skip ahead to the step that follows.

Tools Required

The only tool you will need to install components and perform maintenance is a Philips screwdriver.

6-1 Static-Sensitive Devices

Electric Static discharge (ESD) can damage electronic components. To prevent damage to any printed circuit boards (PCBs), it is important to handle them very carefully. The following measures are generally sufficient to protect your equipment from ESD damage.

Precautions

- Use a grounded wrist strap designed to prevent static discharge.
- Touch a grounded metal object before removing any board from its anti-static bag.
- Handle a board by its edges only; do not touch its components, peripheral chips, memory modules or gold contacts.
- When handling chips or modules, avoid touching their pins.
- Put the motherboard, add-on cards and peripherals back into their anti-static bags when not in use.
- For grounding purposes, make sure your computer chassis provides excellent conductivity between the power supply, the case, the mounting fasteners and the motherboard.

Unpacking

The motherboard is shipped in antistatic packaging to avoid static damage. When unpacking the board, make sure the person handling it is static protected.

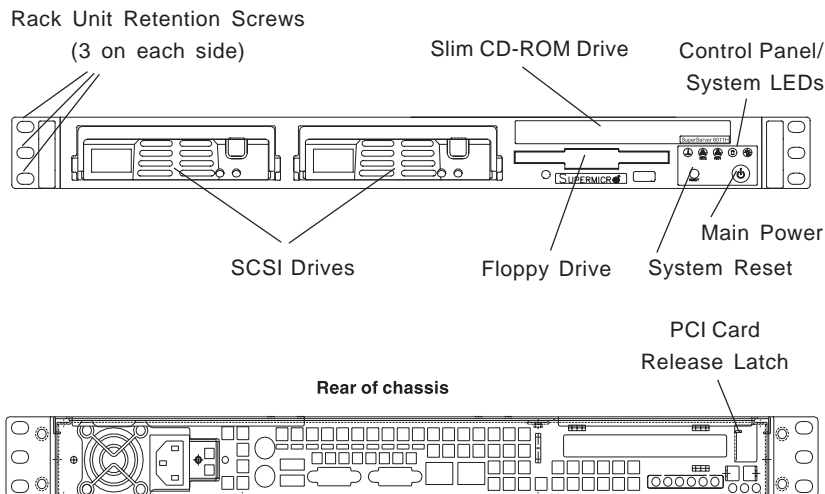

Figure 6-1. Chassis Front and Rear Views

6-2 Control Panel

The control panel (located on the front of the chassis) must be connected to the JF1 connector on the motherboard to provide you with system status indications. A ribbon cable has bundled these wires together to simplify the connection. Connect the cable from JF1 on the motherboard to JP4 on the Control Panel PCB (printed circuit board). Make sure the red wire plugs into pin 1 on both JF1 and JP4. Pull all excess cabling out of the airflow path. The LEDs inform you of system status. See "Chapter 3: System Interface" for details on the LEDs and the control panel buttons. Details on JF1 can be found in the "Chapter 5: Advanced Motherboard Installation."

6-3 System Fans

One 10-cm blower fan provides all the cooling needed for the Super-Server 6011H. The chassis includes air seals under the blower fan and at the chassis cross section, which separates the drive bay area from the motherboard area of the chassis to promote better airflow. It is very important that the air seal is properly installed and making a good seal in order for the cooling air to circulate properly through the chassis. See Figure 6-3.

System Fan Failure

The blower fan runs at 3800 RPM. If the fan fails, the ambient air temperature in the chassis will rise and activate the overheat LED on the control panel. You will need to power down the system to replace the blower fan.

Replacing System Cooling Fans

1. Removing the blower fan:

After turning off the power to the system, first remove the chassis cover and unplug the fan cable from the motherboard. Lift the blower fan from the mounting posts and pull it completely out from the motherboard. See Figure 6-3.

2. Installing a new blower fan:

Replace the failed fan with an identical 10-cm, 12 volt fan (available from Supermicro). Position the new fan at its proper place in the chassis, by fitting the fan onto the fan mounting posts in the chassis. After the new fan has been installed, plug the fan cable back into the same chassis fan header on the motherboard from which you removed it. Make sure the air seal under the fan is properly installed and is creating a good seal. Power up the system and check that the fan is working properly and that the LED on the control panel has turned off. Finish by replacing the top panel of the chassis.

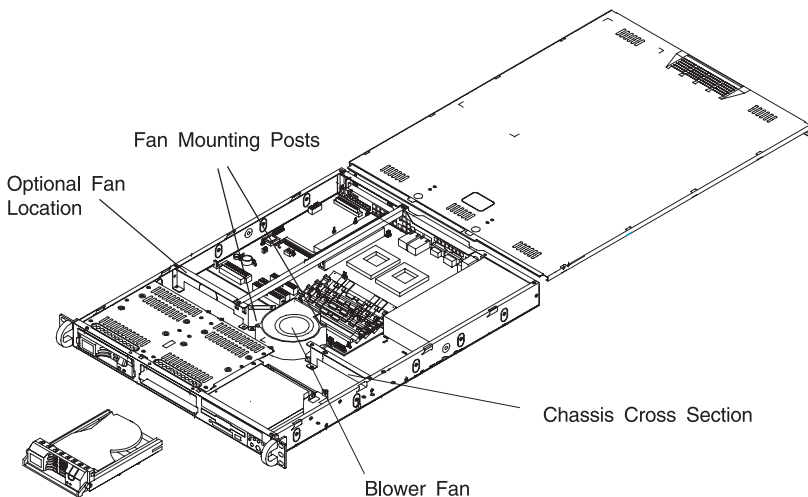

Figure 6-3. System Cooling Fans

6-4 Drive Bay Installation/Removal

Accessing the Drive Bays

SCSI Drives: You do not need to access the inside of the chassis to replace or swap SCSI drives. Proceed to the next step for instructions.

Note: You must use standard 1" high, 80-pin SCA SCSI drives in the SuperServer 6011H.

CD-ROM/Floppy Disk Drive: For installing/removing the CD-ROM or floppy disk drive, you will need to gain access to the inside of the 6011H by removing the top cover of the chassis. Proceed to the "CD-ROM and Floppy Drive Installation" section later in this chapter for instructions.

Note: Only a "slim" CD-ROM drive will fit in the 6011H.

SCSI Drive Installation

1. Mounting a SCSI drive in a drive carrier:

The SCSI drives are mounted in drive carriers to simplify their installation and removal from the chassis. These carriers also help promote proper airflow for the SCSI drive bays. For this reason, even empty carriers without SCSI drives installed must remain in the chassis. To add a new SCSI drive, install a drive into the carrier with the printed circuit board side toward the carrier so that the mounting holes align with those in the carrier. Secure the drive to the carrier with four screws, as shown in Figure 6-4.

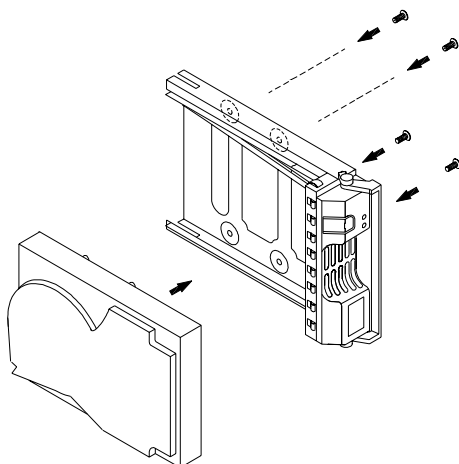

Figure 6-4. Mounting a SCSI Drive in a Carrier



Use caution when working around the SCSI backplane. Do not touch the backplane with any metal objects and make sure no ribbon cables touch the backplane or obstruct the holes, which aid in proper airflow.



Important: Regardless of how many SCSI hard drives are installed, both SCSI drive carriers must remain in the drive bays for proper airflow.

2. Installing/removing hot-swap SCSI drives:

One SCSI drive bay is located in the front of the chassis, making it easily accessible for installation and removal. The SCSI drive is a hot-swap unit, meaning that it can be installed and removed while the system is running. To remove a SCSI drive, first push the release button located beside the drive's LEDs, then swing the colored handle fully out and use it to pull the unit straight out (see Figure 6-5).

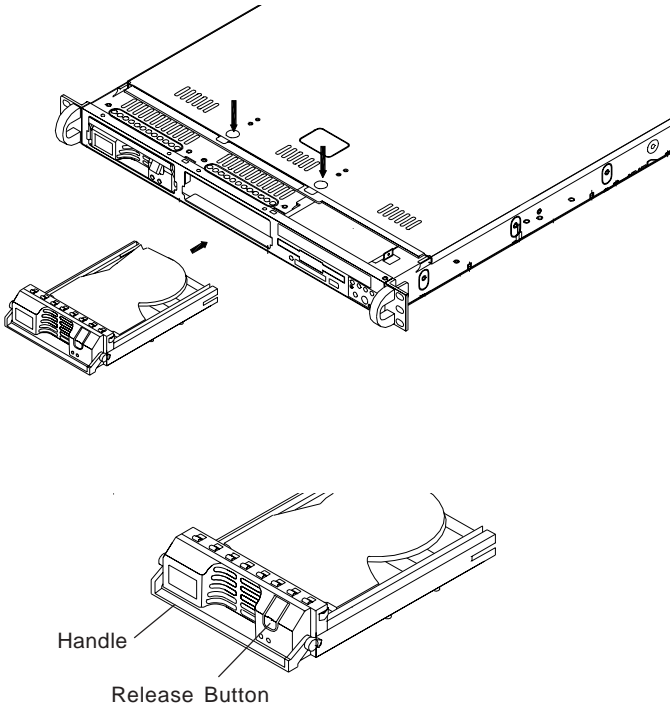

Figure 6-5. Removing SCSI Drives



Important: All SCSI drive carriers must remain in their drive bays to maintain proper airflow.

SCSI Power Cables

SCSI power cables should be routed so that they do not block the airflow through the chassis. There is a 4-pin connector for the power cables.

SCA Backplane

The SCSI drives plug into an SCA backplane that provides power, SCSI ID and bus termination. A RAID controller can be used with the SCA backplane to provide data security. The operating system you use must have RAID support to enable the hot-swap capability of the SCSI drive. The SCA SCSI backplane is already preconfigured, there are no jumpers or switches.

IDE Drive Installation (6011HI only)

1. Mounting an IDE drive in a drive carrier

Like SCSI drives, IDE drives are also mounted in drive carriers to simplify their installation and removal from the chassis. These carriers also help promote proper airflow. For this reason, even empty carriers without IDE drives installed must remain in the chassis. To add a new IDE drive, install a drive into the carrier with the printed circuit board side toward the carrier so that the mounting holes align with those in the carrier. Secure the drive to the carrier with the four screws.

2. Installing/removing IDE drives

The two IDE drive bays are located in the front of the chassis, making them easily accessible for installation and removal. The IDE drives are not hot-swap units, meaning system power must be turned off before installing and/or removing them. To install or remove a drive, first power down the system and then remove the top cover of the chassis. Unscrew the retention screw at the top center of the drive, then push the drive carrier out from the back until you can grasp and pull it out through the front of the chassis (see Figure 6-6). Reverse this procedure when installing a drive carrier, making sure you screw in the retention screw. Replace the top cover when finished.

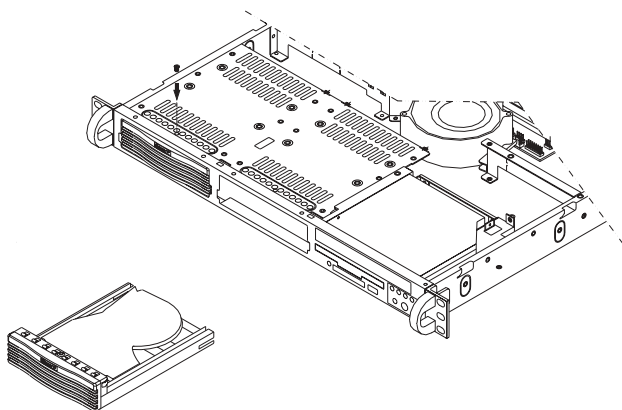
Figure 6-6. Removing IDE Drives (6011HI)

CD-ROM and Floppy Drive Installation

The top cover of the chassis must be opened to gain full access to the CD-ROM and floppy drive bays. The CD-ROM drive must be one with a "slim" profile to fit into the 6011H.

First, release the retention screws that secure the unit to the rack. Grasp the two handles on either side and pull the unit straight out until it locks (you will hear a "click"). Next, depress the two buttons on the top of the chassis to release the top cover and at the same time, push the cover away from you until it stops. You can then lift the top cover from the chassis to gain full access to the inside of the server. You must power down the system before installing or removing floppy or IDE drives.

Drives mount on rails and should "click" into place to be correctly and fully installed in their bays.

- The floppy disk drive cable has seven twisted wires.
- A red mark on a cable typically designates the location of pin 1.
- A single floppy disk drive ribbon cable has 34 wires and two connectors to provide for two floppy disk drives. The connector with twisted wires always connects to drive A, and the connector that does not have twisted wires always connects to drive B.

6-5 Power Supply

The SuperServer 6011H has a single 250 watt power supply, which has an auto-switching capability that enables it to automatically sense and operate with either a 110 or 220 volt input. A power on/off switch is located at the back of the power supply. Turning this power switch to the off position will remove both main and standby power from the system. (If there is no power switch, simply unplug the AC power cord.)

Power Supply Failure

If the power supply unit fails, the system will shut down and you will need to replace the power supply unit. Replacement units can be ordered directly from Supermicro. See contact information in the Preface.

Replacing the Power Supply

1. Accessing the inside of the SuperServer 6011H:

To replace a power supply, you must first remove the top chassis cover. To do so, first release the retention screws that secure the unit to the rack. Grasp the two handles on either side and pull the unit straight out until it locks (you will hear a "click"). Next, depress the two buttons on the top of the chassis to release the top cover and push it away from you. You can then lift the top cover from the chassis to gain full access to the inside of the server.

2. Removing the power supply: (See Figure 6-6)

First unplug the power cord from the system. To remove the failed power unit, remove the two screws on the back of the power supply, which secure it to the chassis. You can then lift the unit straight out of the chassis. (The power cord should have already been removed.)

3. Installing a new power supply:

Replace the failed unit with another unit of the same wattage. It is highly recommended to replace it with exactly the same model power supply. Carefully insert the new unit into position in the chassis and secure it with the two screws at the rear of the unit. Before reconnecting the power cord, make sure the power switch on the power supply is in the off position. Then reconnect the power cord, replace the chassis top cover and reposition the unit back into the rack. Finish by turning the power switch on the power supply on, and then depress the power button on the front of the system.

Figure 6-7. Chassis Rear View

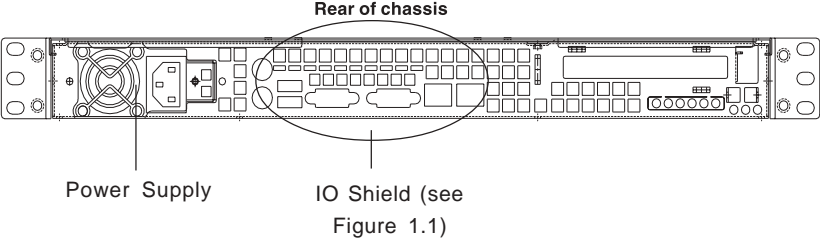

Chapter 7

BIOS

7-1 Introduction

This chapter describes the AMIBIOS for the P3TDER+. The AMI ROM BIOS is stored in a Flash EEPROM and can be easily upgraded using a floppy disk-based program.

Note: Due to periodic changes to BIOS, some settings may have been added or deleted and might not yet be recorded in this manual. Refer to the Manual Download area of our web site for any changes to BIOS that are not reflected in this manual.

System BIOS

The BIOS is the Basic Input Output System used in all IBM® PC, XT™, AT®, and PS/2® compatible computers. The BIOS ROM stores the system parameters, such as amount of memory, type of disk drives and video displays, etc. BIOS ROM requires very little power. When the computer is turned off, a back-up battery provides power to the BIOS ROM, enabling it to retain the system parameters. Each time the computer is powered-on, the computer is then configured with the values stored in the BIOS ROM by the system BIOS, which gains control when the computer is powered on.

How To Change the Configuration Data

The configuration data that determines the system parameters may be changed by entering the BIOS Setup utility. This Setup utility can be accessed by pressing at the appropriate time during system boot.

Starting the Setup Utility

Normally, the only visible POST (Power On Self Test) routine is the memory test. As the memory is being tested, press the <Delete> key to enter the main menu of the BIOS Setup utility. From the main menu, you can access the other setup screens, such as the Chipset and Power menus. Section 4-3 gives detailed descriptions of each parameter setting in the Setup utility.

An AMIBIOS identification string is displayed at the left bottom corner of the screen, below the copyright message.

7-2 BIOS Features

- Supports Plug and Play V1.0A and DMI 2.3
- Supports Intel PCI (Peripheral Component Interconnect) (PME) local bus specification 2.2
- Supports Advanced Power Management (APM) specification v 1.1
- Supports ACPI
- Supports Flash ROM

AMIBIOS supports the LS120 drive made by Matsushita-Kotobuki Electronics Industries Ltd. The LS120:

- Can be used as a boot device
- Is accessible as the next available floppy drive

AMIBIOS supports PC Health Monitoring chips. When a failure occurs in a monitored activity, AMIBIOS can sound an alarm and display a message. The PC Health Monitoring chips monitor:

- CPU temperature
- Chassis intrusion detector
- Five positive voltage inputs
- Four fan speed monitor inputs

7-3 Running Setup

**Optimal default settings are in bold text unless otherwise noted.*

The BIOS setup options described in this section are selected by choosing the appropriate text from the Standard Setup screen. All displayed text is described in this section, although the screen display is often all you need to understand how to set the options (see on next page).

The Main BIOS Setup Menu

Press the <Delete> key during the POST (Power On Self Test) to enter the Main Menu of the BIOS Setup Utility. All Main Setup options are described in this section. The Main BIOS Setup screen is displayed below.

BIOS SETUP UTILITY	
Main Advanced Chipset PCIPnP Power Boot Security Exit	
AMIBIOS Version : 07.00xx BIOS Build Date : xx/xx/xx BIOS ID : Processor Type : PentiumIII™ Processor Speed : 933MHz System Memory : 256MB System Time [10:10:00] System Date [Thu 08/24/00]	↔ Select Screen ↑↓ Select Item +- Change Field Tab Select Field F1 General Help F10 Save and Exit ESC Exit
V02.03 (C)Copyright 1985-2000, American Megatrends, Inc.	

Use the Up/Down arrow keys or the <Tab> key to move between the different settings in the above menu.

When the items "System Time", and "System Date" are highlighted, type in the correct time/date in the time field, and then press "Enter". The date must be entered in MM/DD/YY format. The time is entered in HH:MM:SS format. The time is in also 24-hour format. For example, 5:30 a.m. appears as 05:30:00 and 5:30 p.m. as 17:30:00.

Press the <ESC> key to exit the Main Menu and use the Left/Right arrow keys to enter the the other categories of BIOS settings. The next section is described in detail to illustrate how to navigate through the menus.

Note: Items displayed in gray are preset and cannot be selected. Items with a blue arrow are commands, not options (i.e. Discard Changes).

7-4 Advanced BIOS Setup

Choose Advanced BIOS Setup from the AMIBIOS Setup Utility main menu with the Left/Right arrow keys. You should see the following display. Select one of the items in the left frame of the screen, such as SuperIO Configuration, to go to the sub screen for that item. Advanced BIOS Setup options are displayed by highlighting the option using the arrow keys. All Advanced BIOS Setup options are described in this section.

BIOS SETUP UTILITY	
Main	Advanced
Chipset PCI/PnP Power Boot Security Exit Setup Warning Setting items on this screen to incorrect values may cause the system to malfunction! > SuperIO Configuration > IDE Configuration > Floppy Configuration > Boot Settings Configuration > Event Log Configuration > Peripheral Device Configuration > System Health Monitor > Remote Access Configuration	Configure SuperIO Chipset Winbond627F ↔ Select Screen ↑↓ Select Item Enter Go to Sub Screen F1 General Help F10 Save and Exit ESC Exit
V7.00 (C)Copyright 1985-2001, American Megatrends, Inc.	

Use the Up/Down arrow keys to select the "Super I/O Configuration" line.

When the "Super IO Configuration" line is highlighted, hit "ENTER" to display its menu.

The following Super IO Configuration screen will appear. Here you can select your options for the your computer's I/O (Input/Output) devices.

Super I/O Configuration

BIOS SETUP UTILITY	
Advanced	
<u>Configure Winbond627F Serial Port(s) and Parallel P</u>	
Serial Port1 Address	[3F8]
Serial Port1 IRQ	[4]
Serial Port2 Address	[2F8]
Serial Port2 IRQ	[3]
Serial Port2 Mode	[Normal]
Parallel Port Address	[378]
Parallel Port IRQ	[7]
Parallel Port Mode	[ECP]
ECP Mode DMA Channel	[3]
	← Select Screen ↑↓ Select Item +- Change Option F1 General Help F10 Save and Exit ESC Exit
V07.00 (C)Copyright 1985-2001, American Megatrends, Inc.	

The Super IO Configuration includes the following items:

Serial Port 1 Address

This option specifies the base I/O port address of serial port 1. The settings for this item include Disabled, **3F8** and 3E8 and 2E8. Select the desired setting and then press "Enter".

Serial Port 1 IRQ

This option specifies the Interrupt Request address of serial port 1. The settings for this item include Disabled, **4** and 3.

Serial Port 2 Address

This option specifies the base I/O port address of serial port 2. The settings for this item include Disabled, **2F8**, 3E8 and 2E8.

Serial Port 2 IRQ

This option specifies the Interrupt Request address of serial port 2. The settings for this item include Disabled, 4 and 3.

Serial Port 2 Mode

You may use this setting when connecting an infrared device to serial port 2. The settings are **Normal**, Sharp-IR, SIR and Consumer.

Parallel Port Address

This option specifies the I/O address used by the parallel port. The settings for this item include Disabled, **378**, 278 and 3BC. Select your setting and then press "Enter".

Parallel Port IRQ

This option allows the user to set the Parallel Port IRQ. The settings for this item include 5 and 7.

Parallel Port Mode

This option specifies the parallel port mode. The settings for this item include Normal, Bi-directional, EPP and **ECP**.

ECP Mode DMA Channel

This option allows the user to set the setting for the ECP Mode of the DMA Channel. The settings for this item include **0**, 1 and 3.

IDE Configuration

Primary IDE Master

When entering "Setup", BIOS automatically detects the presence of IDE devices and displays the auto detection status of the IDE devices. You can also manually configure the IDE drives by providing the following information:

The following options allow the user to configure the IDE devices. When the desired item is highlighted (selected), press "Enter" and the following screen will be displayed:

Type

This option sets the type of device that the AMIBIOS attempts to boot from after the AMIBIOS POST routine is completed. The settings include Not Installed, **Auto**, CDROM and ARMD. The "Auto" setting allows BIOS to automatically detect the presence of the IDE controller.

LBA/Large Mode

LBA (Logical Block Addressing) is a method of addressing data on a disk drive. In LBA mode, the maximum drive capacity is 137 GB. The settings are Disabled and **Auto**. Select "Disabled" to disable LBA mode. Select "Auto" to enable LBA mode if your device supports it and is not already formatted with the LBA mode.

Block (Multi-Sector Transfer) Mode

This option sets the block mode multi sector transfers option. The settings include Disabled and **Auto**. Disabled: This option prevents the BIOS from using Multi-Sector Transfer on the specified channel. The data to and from the device will occur one sector at a time. Auto: This option allows the BIOS to auto detect device support for Multi-Sector Transfers on the specified channel. If supported, this option allows the BIOS to auto detect the number of sectors per block for transfer from the hard disk drive to memory. The data transfer to and from the device will occur multiple sectors at a time (if the device supports it).

PIO Mode

IDE PIO (Programmable I/O) mode programs timing cycles between the IDE drive and the programmable IDE controller. As the PIO mode increases, the cycle time decreases. The settings are: **Auto**, 0, 1, 2, 3 and 4.

DMA Mode

This item allows the users to select the DMA mode. The settings are: **Auto**, SWDMA0, SWDMA1, SWDMA2, MWDMA0, MWDMA1, MWDMA2, UWDMA0, UWDMA1, UWDMA2, UWDMA3 and UWDMA4. Select Auto to auto detect the DMA Mode. Select SWDMA0 through SWDMA2 to set single word DMA0 through DMA2. Select MWDMA0 through MWDMA2 to set Multi-word DMA0 through DMA2. Select UDMA0 through UDMA4 to set Ultra DMA0 through Ultra DMA4.

S.M.A.R.T.

S.M.A.R.T stands for Self-Monitoring Analysis and Reporting Technology, a feature that can help predict impending drive failures. The settings are **Auto**, Disabled and Enabled. Select "Enabled" or "Disabled" to enable or disable the S.M.A.R.T. Select "Auto" to auto detect the S.M.A.R.T. function.

32Bit Data Transfer

The settings are Auto, Disabled and **Enabled**. Select "Enabled" or "Disabled" to enable or disable the 32-bit Data Transfer function. Select "Auto" to auto detect the 32-bit Data Transfer function.

ARMD Emulation Type

This option is used to select the emulation used when configuring an LS120, MO (Magneto-Optical), or Iomega Zip drive. The settings are **Auto**, Floppy and HardDisk.

Primary IDE Slave

When the system enters "Setup", BIOS automatically detects the presence of IDE devices. This option displays the auto detection status of IDE devices. The settings for "Primary IDE Slave" are the same as those for the "Primary IDE Master".

Secondary IDE Master

This displays the status of the auto detection of IDE devices. The settings for "Secondary IDE Master" are the same as those for the "Primary IDE Master".

Secondary IDE Slave

This displays the status of the auto detection of IDE devices. The settings for "Secondary IDE Slave" are the same as those for the "Primary IDE Master".

Hard Disk Write Protect

This item allows the user to prevent the hard disk from being overwritten. The options are Enabled or **Disabled**. Enabled allows the drive to be used normally; read, write and erase functions can all be performed. Disabled prevents the hard disk from being erased. This function is effective only when the device is accessed through BIOS.

Floppy Configuration

Floppy A

Use this option to specify which type of floppy drive you have installed in the A drive. The settings are Disabled, 360 KB 5 1/4", 1.2 MB 5 1/4", 720 KB 3 1/2", **1.44 MB 3 1/2"** and 2.88 MB 3 1/2".

Floppy B

Use this option to specify which type of floppy drive you have installed in the B drive. The settings are Disabled, 360 KB 5 1/4", 1.2 MB 5 1/4", 720 KB 3 1/2", **1.44 MB 3 1/2"** and 2.88 MB 3 1/2".

Floppy Drive Seek

Use this option to Enable or **Disable** the floppy seek routine on bootup.

Boot Settings Configuration

Quick Boot

This option allows the BIOS to skip certain tests that are normally performed on boot up. You can disable the option to speed up boot time. The settings are **Disabled** and Enabled.

Quiet Boot

If Disabled, this option will cause the normal POST messages to be displayed upon setup. When Enabled, the OEM logo is displayed instead of the POST messages. The settings are Enabled and **Disabled**.

Add-On ROM Display Mode

Set this option to display add-on ROM (read-only memory) messages. The settings for this option are **Force BIOS** and Keep Current. Force BIOS allows the computer to force a third party BIOS to display during system boot. Keep Current has the system display AMIBIOS information on bootup.

BootUp Num Lock

This option is used to select the status of the Number Lock function on your keyboard on bootup. The settings are **On** and Off.

PS/2 Mouse Support

This option specifies whether a PS/2 Mouse will be supported. Settings are **Enabled** and Disabled.

Typematic Rate

Set this option to select the rate at which the computer repeats a key that is held down. Settings are **Fast** and Slow. Fast: This sets the rate the computer repeats a key to over 20 times per second. Under normal operations, this setting should not be changed. Slow: This sets the rate the computer repeats a key to under 8 times per second.

System Keyboard

This option is to let the system know if a keyboard is **Present** or Absent.

Primary Display

This option specifies the type of monitor display you have installed on the system. The settings are Absent, **VGA/EGA**, Color 40 x 25, Color 80 x 25 and monochrome.

Boot to OS/2

This option can be used to boot the system to an OS/2 operating system. The settings are **No** and Yes.

Wait for F1 if Error

This settings for this option are **Enabled** and Disabled. Disabled: This prevents the AMIBIOS from waiting on an error for user intervention. This setting should be used if there is a known reason for a BIOS error to appear. An example would be if a system administrator must remote boot a system that system does not have a keyboard currently attached. If this setting is set, the system will continue to bootup to the operating system. If 'F1' is enabled, the system will wait until the BIOS setup is entered. Enabled: This option makes the system BIOS to wait on any error. If an error

is detected, pressing <F1> will enter Setup and the proper BIOS setting can be adjusted to fix the problem. This normally happens when system hardware has been upgraded and BIOS has not been set to recognize it.

Hit "DEL" Message Display

This option tells the system to display or not display the "Hit Delete to Enter Setup" message. The settings are **Enabled** and Disabled.

Processor Serial Number

This option allows the operating system and applications to be able to read the CPU serial number from your CPUs. The settings are Enabled and **Disabled**. (*Note: This option is not available for Intel Celeron Processors because these processors do not contain a processor serial number.)

Internal Cache

This option is for enabling or disabling the internal CPU L1 cache. Settings include Disabled, Write-Thru, **Write-Back** and Reserved. Disabled: This option prevents the system from using the internal CPU L1 cache. This setting should be used to slow the computer system down or to troubleshoot error messages. Write-Thru: This option allows the computer system to use the internal CPU L1 cache as Write-Through cache. Write-Through cache is slower than Write-Back cache. It performs write operations to the internal L1 CPU cache and system memory simultaneously. Write-Back: This option allows the computer system to use the internal CPU L1 cache as Write-Back cache. Write-Back cache is faster than Write-Through cache. Write-Back cache is a caching method in which modifications to data in the cache aren't copied to the cache source until absolutely necessary. Write-back caching is available on all CPUs supported by this BIOS. With these CPUs, write operations stored in the L1 cache aren't copied to main memory until absolutely necessary. This is the default setting.

System BIOS Cacheable

This option enables you to move the system BIOS to the memory cache to improve performance. Settings are **Enabled** and Disabled.

Event Log Configuration

Event Logging

This option **Enables** or Disables the logging of events. You can use this screen to select options for the Event Log Configuration Settings. You can access sub screens to view the event log and mark all events as read. Use the up and down arrow keys to select an item, and the plus (+) and minus (-) keys to change the option setting. The settings are described below.

ECC Event Logging

This option Enables or **Disables** the logging of ECC events. The events logged by AMIBIOS are post errors such as a bad BIOS, floppy errors, or hard drive errors.

View Event Log

Highlighting this and pressing <Enter> will allow you to view the unread events from the event log area.

Mark All Events As Read

Highlighting [OK] and pressing <Enter> will mark all events in the log area as having been read. The settings are OK and **Cancel**.

Peripheral Device Configuration

Onboard SCSI option-ROM

This option allows you to **Enable** or Disable booting up the system from an onboard SCSI device.

Onboard LAN1 option-ROM

This option allows you to Enable or **Disable** booting up the system from an onboard LAN1 device (a PXE feature).

Onboard LAN2 option-ROM

This option allows you to Enable or **Disable** booting up the system from an onboard LAN2 device (a PXE feature).

Power Lost Control

This option determines how the system will respond when power is reapplied after a power loss condition. Choose **Enabled** to automatically start up the system when power is reapplied. Disabled Off means you must push the main power button to restart the system after power is restored.

System Health Monitor

The BIOS continuously monitors the health of your system by measuring certain voltage levels and temperatures.

CPU1 Current Temperature/CPU2 Current Temperature

This reading displays the real-time temperatures of CPU1 and CPU2.

System Overheat Warning

This option allows you to **Enable** or Disable a system overheat warning signal, used to notify you in the event of a dangerous rise in heat levels.

Overheat Warning Temperature

This option allows you to specify the temperature threshold that, when exceeded, will trigger the overheat warning alarm.

The rest of the System Health Monitor menu lists various voltages and temperatures as they are currently being measured. These include CPU temperature, CPU voltage, the rpms of the CPU, chassis and thermal control fans as well as various other voltages.

Remote Access Configuration

Remote Access

When Enabled, this option allows the user to redirect the console (display) through the COM port. This is useful when two computers are hooked up to a single monitor. When enabled, the user can toggle the display from one system to the other using the <Tab> key. The function keys are disabled when this setting is enabled. The settings are Serial (ANSI) and **Disabled**.

7-5 Chipset Setup

Choose Chipset Setup from the AMIBIOS Setup Utility main menu. The screen is shown below. All Chipset Setup options are described following the screen.

BIOS SETUP UTILITY							
Main	Advanced	Chipset	PCIPnP	Power	Boot	Security	Exit
Write Combining for P6 to PCI		[Enabled]					
Act to DeAct		[6 Clks]					
Act to Read/Write		[3 Clks]					
RA Cycle Time		[8 Clks]					
SDRAM CAS Latency		[CAS Latency 3]					
Memory Auto Precharge		[Disabled]					
SDRAM Fast Timing		[11-1-1]					
Memory Writing Posting		[Enabled]					
Fast ECC Enable		[Disabled]					
Scrubbing Enable		[Disabled]					
AGP Device Address Space Size		[32 MB]					↔ Select Screen
AGP Operations		[Enabled]					↑↓ Select Item
MPS 1.4 Support		[Enabled]					+ - Change Option
EMM 386 Support		[Disabled]					F1 General Help
Watchdog Timer		[Disabled]					F10 Save and Exit
							ESC Exit
V02.03 (C)Copyright 1985-2000, American Megatrends, Inc.							

Write Combining for P6-to-PCI

This settings for this option are Disabled and **Enabled**. Select "Enabled" to enable the function of Write Combining for P6-to-PCI.

Act to Deact

This settings for this option are **6 Clks** and 5 Clks.

Act to Read/Write

This settings for this option are **3 Clks** and 2 Clks.

RAS Precharge Time

This option defines the RAS precharge time. Settings are **3 Clks** and 2 Clks.

RAS Cycle Time

This option defines the RAS cycle time. Settings include 10 Clks, 9 Clks, **8 Clks** and 7 Clks.

SDRAM CAS Latency

This option defines the SDRAM CAS Latency settings. CAS stands for Column Address Strobe. Settings include **CAS Latency 3** and CAS Latency 2.

Memory Auto Precharge

The settings are **Enabled** and Disabled.

SDRAM Fast Timing

This option defines the Fast timing settings for SDRAM . Settings include **11-1-1** and 10-1-1.

Memory Writing Posting

The settings are **Enabled** and Disabled.

Fast ECC Enable

The settings are Enabled and **Disabled**.

Scrubbing Enable

The settings are Enabled and **Disabled**.

AGP Device Address Space Size

This settings for this option are **32MB**, 64MB, 128MB, 256MB and 512MB.

AGP Operations

This settings for this option are **Enabled** and Disabled.

MPS 1.4 Support

The settings for this option are **Enabled** and Disabled.

EMM 386

This settings for this option are Enabled and **Disabled**.

Watchdog Timer

The settings for this option are **Disabled**, 2 minutes, 5 minutes, 10 minutes and 15 minutes.

7-6 PCI PnP Setup

Choose PCI/PnP Setup from the AMIBIOS Setup main menu. All PCI/PnP options are described in this section. The PCI/PnP Setup screen is shown below.

BIOS SETUP UTILITY							
Main	Advanced	Chipset	PCI/PnP	Power	Boot	Security	Exit
Plug & Play O/S			[No]				
Reset Config Data			[No]				
PCI Latency Timer			[64]				
Allocate IRQ to VGA			[Yes]				
Palette Snooping			[Disabled]				
PCI IDE BusMaster			[Disabled]				
USB Controller			[Enabled]				
			[Disabled]				
IRQ3			[Available]				
IRQ4			[Available]				
IRQ5			[Available]				
IRQ7			[Available]				
IRQ9			[Available]				
IRQ10			[Available]				
IRQ11			[Available]				
IRQ14			[Available]				
IRQ15			[Available]				
						No: lets the BIOS configure all the devices in the system.	
						Yes: lets the operating system configure Plug and Play (PnP) devices not required for boot if your system has a Plug and Play operating system.	
						↔ Select Screen	
						↑↓ Select Item	
						+ - Change Option	
						F1 General Help	
						F10 Save and Exit	
						ESC Exit	
V07.00 (C)Copyright 1985-2001, American Megatrends, Inc.							

Plug & Play O/S

The settings for this option are Yes and **No**. Selecting Yes will allow the operating system to configure PnP devices not required for setup (provided your system has an O/S that supports PnP devices). Selecting No lets BIOS configure PnP devices.

Reset Configuration Data

Choosing the Yes setting will cause the PnP configuration data in the BIOS to be cleared on the next boot up. Choosing the **No** setting does not force PnP data to be cleared on the next boot.

PCI Latency Timer

This option specifies the latency timing of the PCI clocks for all PCI devices. Settings include 32, **64**, 96, 128, 160, 192, 224 and 248 PCI clocks.

Allocate IRQ to PCI VGA

This option lets you allocate an interrupt request (IRQ) to the PCI VGA adapter card (if used). The settings are **Yes** and No.

Palette Snooping

When enabled, this option informs PCI devices that an ISA graphics device is installed. The settings are **Disabled** and Enabled. This does not necessarily indicate a physical ISA adapter card. The graphics chipset can be mounted on a PCI card. Always check with your adapter card manuals first, before modifying the default settings in the BIOS.

PCI IDE BusMaster

The settings for this option are **Disabled** and Enabled. Enable to specify that the IDE controller on the PCI bus has bus mastering capabilities.

USB Function

The settings for this option are Disabled and **Enabled**. Disabled prevents the use of the USB ports and Enabled allows the use of the USB ports.

IRQ 3

IRQ 4

IRQ 5

IRQ 7

IRQ 9

IRQ 10**IRQ 11****IRQ 14****IRQ 15**

The settings for the above options are **Available** and **Reserved**. Available allows the specified IRQ to be available for use by PCI/PnP devices. Reserved means the specified IRQ is reserved for use by Legacy ISA devices.

7-7 Power Setup

Choose Power Setup from the AMIBIOS Setup main menu. All Power Setup options are described in this section. The Power Setup screen is shown below.

BIOS SETUP UTILITY							
Main	Advanced	Chipset	PCIPnP	Power	Boot	Security	Exit
ACPI Aware O/S				[No]			
Power Button Mode				[On/Off]			
Suspend Time Out (Minutes)				[Off]			
PME Resume				[Disabled]			
RI/WOR Resume				[Disabled]			
Chassis Intrusion Support				[Disabled]			
							↔ Select Screen
							↑↓ Select Item
							+ - Change Option
							F1 General Help
							F10 Save and Exit
							ESC Exit
V07.00 (C)Copyright 1985-2001, American Megatrends, Inc.							

ACPI Aware O/S

This option allows the system to utilize Intel's ACPI (Advanced Configuration and Power Interface) specification. Settings are **No** and **Yes**. DOS®, Windows 3.x®, and Windows NT® are examples of non-ACPI aware operating systems. Windows 95®, Windows 98®, Windows ME® and Windows 2000® are examples of ACPI aware operating systems.

Power Button Mode

This option allows you to specify how the power button will function. **On/Off** allows it to function normally. Choosing **Suspend** allows you to put the system in a suspend (sleep) state when depressing the button.

Suspend Timeout

This option specifies if BIOS is to monitor for display activity when in a power saving state. The settings include **Off**, 1, 2, 3, 4, 5, 6, 7, 8, 9 and 10 (minutes).

PME Resume

This allows you to wake up the system from a PME device. The settings for this option **Disabled** and **Enabled**.

RI/WOR Resume

This option allows the system to resume the Ring Indicator/Wake-on-Ring function. The settings for this option **Disabled** and **Enabled**.

Chassis Intrusion Support

This option allows BIOS to help you support the chassis intrusion function. When **Enabled**, the system will freeze if a chassis intrusion is detected. The settings are **Enabled** and **Disabled**.

7-8 Boot Setup

Choose Boot Setup from the AMIBIOS Setup main menu. All Boot Setup options are described in this section. The Boot Setup screen is shown below.

BIOS SETUP UTILITY							
Main	Advanced	Chipset	PCIPnP	Power	Boot	Security	Exit
> <u>Boot Device Priority</u> > Hard Disk Drives > Removable Devices > ATAPI CDROM Drives						↔ Select Screen ↑↓ Select Item Enter Go to Sub Screen F1 General Help F10 Save and Exit ESC Exit	
V02.03 (C)Copyright 1985-2000, American Megatrends, Inc.							

Boot Device Priority

1st Boot Device

The following options are used to specify the order of the boot sequence that will be followed from the available system devices. The settings for the 1st Boot Device are **Removable Device**, ATAPI CDROM, Hard Drive and Disabled.

2nd Boot Device

The settings for the 2nd Boot Device are Removable Device, **ATAPI CDROM**, Hard Drive and Disabled.

3rd Boot Device

The settings for the 3rd Boot Device are Removable Device, ATAPI CDROM, **Hard Drive** and Disabled.

Hard Disk Drives

Use this screen to view the boot sequency of hard drives that have been auto-detected or entered manually on your system.

Removable Devices

Use this screen to view the boot sequency of the removable devices that have been auto-detected or entered manually on your system.

ATAPI CDROM Drives

Use this screen to view the boot sequency ofthe ATAPI CDROM drives that have been auto-detected or entered manually on your system.

7-9 Security Setup

Choose Security Setup from the AMIBIOS Setup main menu. All Security Setup options are described in this section. The Security Setup screen is shown below.

BIOS SETUP UTILITY							
Main	Advanced	Chipset	PCI/PnP	Power	Boot	Security	Exit
Supervisor Password :						Not Installed	
User Password :						Not Installed	
> <u>Change Supervisor Password</u>							
> Change User Password							
> Clear User Password							
Boot Sector Virus Protection						[Disabled]	
						Install or Change the password.	
						↔ Select Screen	
						↑↓ Select Item	
						Enter Go to Sub Screen	
						F1 General Help	
						F10 Save and Exit	
						ESC Exit	
V02.03 (C)Copyright 1985-2000, American Megatrends, Inc.							

Supervisor Password

User Password

AMIBIOS provides both Supervisor and User password functions. If you use both passwords, the Supervisor password must be set first. The system can be configured so that all users must enter a password every time the system boots or when AMIBIOS Setup is executed, using either or both the Supervisor password or/and the User password. The Supervisor and User passwords activate two different levels of password security. If you select password support, you are prompted for a one to six character password. Type the password on the keyboard. The password does not appear on the screen when typed. Make sure you write it down. If you forget it, you must clear CMOS and reconfigure. **Remember your Pass-**

word! Keep a record of the new password when the password is changed. If you forget the password, you must erase the system configuration information in CMOS.

Change Supervisor Password

This option allows you to change a supervisor password that was entered previously.

Change User Password

This option allows you to change a user password that was entered previously.

Clear User Password

Use this option to clear the user password so that it is not required to be entered when the system boots up.

Boot Sector Virus Protection

This option allows you to enable or disable a virus detection program to protect the boot sector of your hard disk drive. The settings for this option **Disabled** and Enabled. If Enabled, AMIBIOS will display a warning when any program (or virus) issues a Disk Format command or attempts to write to the boot sector of the hard disk drive.

7-10 Exit Setup

Choose Exit Setup from the AMIBIOS Setup main menu. All Exit Setup options are described in this section. The Exit Setup screen is shown below.

BIOS SETUP UTILITY							
Main	Advanced	Chipset	PCIPnP	Power	Boot	Security	Exit
> <u>Exit Saving Changes</u> > Exit Discarding Changes > Load Optimal Defaults > Load Fail-Safe Defaults > Discard Changes							Exit system setup with saving the changes.
							↔ Select Screen ↑↓ Select Item Enter Go to Sub Screen F1 General Help F10 Save and Exit ESC Exit
V02.03 (C)Copyright 1985-2000, American Megatrends, Inc.							

Exit Saving Changes

Highlighting this setting and then pressing <Enter> will save any changes you made in the BIOS Setup program and then exit. Your system should then continue with the boot up procedure.

Exit Discarding Changes

Highlighting this setting and then pressing <Enter> will ignore any changes you made in the BIOS Setup program and then exit. Your system should then continue with the boot up procedure.

Load Optimal Defaults

Highlighting this setting and then pressing <Enter> provides the optimum performance settings for all devices and system features.

Load Failsafe Defaults

Highlighting this setting and then pressing <Enter> provides the safest set of parameters for the system. Use them if the system is behaving erratically.

Discard Changes

Highlighting this setting and then pressing <Enter> will ignore any changes you made in the BIOS Setup program but will not exit the BIOS Setup program.

Notes

Appendix A

BIOS Error Beep Codes & Messages

During the POST (Power-On Self-Test) routines, which are performed each time the system is powered on, errors may occur.

Non-fatal errors are those which, in most cases, allow the system to continue the boot-up process. The error messages normally appear on the screen.

Fatal errors are those which will not allow the system to continue the boot-up procedure. If a fatal error occurs, you should consult with your system manufacturer for possible repairs.

These fatal errors are usually communicated through a series of audible beeps. The numbers on the fatal error list, on the following page, correspond to the number of beeps for the corresponding error. All errors listed, with the exception of Beep Code 8, are fatal errors.

AMI BIOS Error Beep Codes

Beep Code	Error Message	Description
1 beep	Refresh	<i>The memory refresh circuitry on the motherboard is faulty</i>
2 beeps	BIOS ROM file absent	<i>The BIOS was unable to find the specific file name required to flash the BIOS</i>
3 beeps	Base 64KB memory failure	<i>Memory failure occurred in the first 64KB of Memory</i>
4 beeps	Flash program successful	<i>The flash was properly programmed with the BIOS ROM file.</i>
5 beeps	Media read error	<i>The floppy or ATAPI media is not presented or cannot be read</i>
6 beeps	Keyboard controller Gate A20 failure	<i>The keyboard controller may be bad. The BIOS cannot switch to protected mode.</i>
7 beeps	Processor exception interrupt error	<i>The CPU generated an exception interrupt</i>
8 beeps	Display memory read/write error	<i>The system video adapter is either missing or its memory is faulty. This is not a fatal error.</i>
10 beeps	Flash erase error	<i>The flash device was unable to be properly programmed.</i>
11 beeps	Flash program error	<i>The flash device was unable to be properly programmed.</i>
12 beeps	BIOS ROM file incorrect size	<i>The BIOS ROM file found does not match the size of the flash device</i>
13 beeps	BIOS ROM image mismatch	<i>The BIOS ROM file layout configuration does not match image present in the flash device.</i>
5 short +_1 long beeps	Memory Error	<i>No memory detected in the system</i>
6 short + 1 long beeps	Memory Error	<i>EDO memory detected in system</i>
7 short + 1 long beeps	SMBUS Error	<i>SMBUS error</i>

Appendix B

AMIBIOS POST Diagnostic Error Codes

When AMIBIOS performs the Power On Self Test, it writes diagnostic codes checkpoint codes to I/O port 0080h. If the computer cannot complete the boot process, diagnostic equipment can be attached to the computer to read I/O port 0080h.

B-1 Uncompressed Initialization Codes

The uncompressed initialization checkpoint codes are listed in order of execution:

Checkpoint	Code Description
D0h	The NMI is disabled. Power on delay is starting. Next, the initialization code checksum will be verified.
D1h	Initializing the DMA controller, performing the keyboard controller BAT test, starting memory refresh, and entering 4 GB flat mode next.
D3h	Starting memory sizing next.
D4h	Returning to real mode. Executing any OEM patches and setting the Stack next.
D5h	Passing control to the uncompressed code in shadow RAM at E000:0000h. The initialization code is copied to segment 0 and control will be transferred to segment 0.
D6h	Control is in segment 0. Next, checking if <Ctrl> <Home> was pressed and verifying the system BIOS checksum. If either <Ctrl> <Home> was pressed or the system BIOS checksum is bad, next will go to check point code E0h. Otherwise, going to checkpoint code D7h.

B-2 Bootblock Recovery Codes

The bootblock recovery checkpoint codes are listed in order of execution:

Checkpoint	Code Description
E0h	The onboard floppy controller if available is initialized. Next, beginning the base 512 KB memory test.
E1h	Initializing the interrupt vector table next.
E2h	Initializing the DMA and Interrupt controllers next.
E6h	Enabling the floppy drive controller and Timer IRQs. Enabling internal cache memory.
Edh	Initializing the floppy drive.
Eeh	Looking for a floppy diskette in drive A:. Reading the first sector of the diskette.
Efh	A read error occurred while reading the floppy drive in drive A:.
F0h	Next, searching for the AMIBOOT.ROM file in the root directory.
F1h	The AMIBOOT.ROM file is not in the root directory.
F2h	Next, reading and analyzing the floppy diskette FAT to find the clusters occupied by the AMIBOOT.ROM file.
F3h	Next, reading the AMIBOOT.ROM file, cluster by cluster.
F4h	The AMIBOOT.ROM file is not the correct size.
F5h	Next, disabling internal cache memory.
FBh	Next, detecting the type of flash ROM.
FCb	Next, erasing the flash ROM.
FDh	Next, programming the flash ROM.
FFh	Flash ROM programming was successful. Next, restarting the system BIOS.

B-3 Uncompressed Initialization Codes

The following runtime checkpoint codes are listed in order of execution. These codes are uncompressed in F0000h shadow RAM.

Checkpoint	Code Description
03h	The NMI is disabled. Next, checking for a soft reset or a power on condition.
05h	The BIOS stack has been built. Next, disabling cache memory.
06h	Uncompressing the POST code next.
07h	Next, initializing the CPU and the CPU data area.
08h	The CMOS checksum calculation is done next.

Checkpoint	Code Description
0Ah	The CMOS checksum calculation is done. Initializing the CMOS status register for date and time next.
0Bh	The CMOS status register is initialized. Next, performing any required initialization before the keyboard BAT command is issued.
0Ch	The keyboard controller input buffer is free. Next, issuing the BAT command to the keyboard controller.
0Eh	The keyboard controller BAT command result has been verified. Next, performing any necessary initialization after the keyboard controller BAT command test.
0Fh	The initialization after the keyboard controller BAT command test is done. The keyboard command byte is written next.
10h	The keyboard controller command byte is written. Next, issuing the Pin 23 and 24 blocking and unblocking command.
11h	Next, checking if <End or <Ins> keys were pressed during power on. Initializing CMOS RAM if the <i>Initialize CMOS RAM in every boot</i> AMIBIOS POST option was set in AMIBCP or the <End> key was pressed.
12h	Next, disabling DMA controllers 1 and 2 and interrupt controllers 1 and 2.
13h	The video display has been disabled. Port B has been initialized. Next, initializing the chipset.
14h	The 8254 timer test will begin next.
19h	The 8254 timer test is over. Starting the memory refresh test next.
1Ah	The memory refresh line is toggling. Checking the 15 second on/off time next.
2Bh	Passing control to the video ROM to perform any required configuration before the video ROM test.
2Ch	All necessary processing before passing control to the video ROM is done. Looking for the video ROM next and passing control to it.
2Dh	The video ROM has returned control to BIOS POST. Performing any required processing after the video ROM had control.
23h	Reading the 8042 input port and disabling the MEGAKEY Green PC feature next. Making the BIOS code segment writable and performing any necessary configuration before initializing the interrupt vectors.

Checkpoint	Code Description
24h	The configuration required before interrupt vector initialization has completed. Interrupt vector initialization is about to begin.
25h	Interrupt vector initialization is done. Clearing the password if the POST DIAG switch is on.
27h	Any initialization before setting video mode will be done next.
28h	Initialization before setting the video mode is complete. Configuring the monochrome mode and color mode settings next.
2Ah	Bus initialization system, static, output devices will be done next, if present. See the last page for additional information.
2Eh	Completed post-video ROM test processing. If the EGA/VGA controller is not found, performing the display memory read/write test next.
2Fh	The EGA/VGA controller was not found. The display memory read/write test is about to begin.
30h	The display memory read/write test passed. Look for retrace checking next.
31h	The display memory read/write test or retrace checking failed. Performing the alternate display memory read/write test next.
32h	The alternate display memory read/write test passed. Looking for alternate display retrace checking next.
34h	Video display checking is over. Setting the display mode next.
37h	The display mode is set. Displaying the power on message next.
38h	Initializing the bus input, IPL, general devices next, if present. See the last page of this chapter for additional information.
39h	Displaying bus initialization error messages. See the last page of this chapter for additional information.
3Ah	The new cursor position has been read and saved. Displaying the <i>Hit </i> message next.
3Bh	The <i>Hit </i> message is displayed. The protected mode memory test is about to start.
40h	Preparing the descriptor tables next.
42h	The descriptor tables are prepared. Entering protected mode for the memory test next.

Checkpoint	Code Description
43h	Entered protected mode. Enabling interrupts for diagnostics mode next.
44h	Interrupts enabled if the diagnostics switch is on. Initializing data to check memory wraparound at 0:0 next.
45h	Data initialized. Checking for memory wraparound at 0:0 and finding the total system memory size next.
46h	The memory wraparound test is done. Memory size calculation has been done. Writing patterns to test memory next.
47h	The memory pattern has been written to extended memory. Writing patterns to the base 640 KB memory next.
48h	Patterns written in base memory. Determining the amount of memory below 1 MB next.
49h	The amount of memory below 1 MB has been found and verified. Determining the amount of memory above 1 MB memory next.
4Bh	The amount of memory above 1 MB has been found and verified. Checking for a soft reset and clearing the memory below 1 MB for the soft reset next. If this is a power on situation, going to checkpoint 4Eh next.
4Ch	The memory below 1 MB has been cleared via a soft reset. Clearing the memory above 1 MB next.
4Dh	The memory above 1 MB has been cleared via a soft reset. Saving the memory size next. Going to check point 52h next.
4Eh	The memory test started, but not as the result of a soft reset. Displaying the first 64 KB memory size next.
4Fh	The memory size display has started. The display is updated during the memory test. Performing the sequential and random memory test next.
50h	The memory below 1 MB has been tested and initialized. Adjusting the displayed memory size for relocation and shadowing next.
51h	The memory size display was adjusted for relocation and shadowing. Testing the memory above 1 MB next.
52h	The memory above 1 MB has been tested and initialized. Saving the memory size information next.
53h	The memory size information and the CPU registers are saved. Entering real mode next.

Checkpoint	Code Description
54h	Shutdown was successful. The CPU is in real mode. Disabling the Gate A20 line, parity, and the NMI next.
57h	The A20 address line, parity, and the NMI are disabled. Adjusting the memory size depending on relocation and shadowing next.
58h	The memory size was adjusted for relocation and shadowing. Clearing the <i>Hit </i> message next.
59h	The <i>Hit </i> message is cleared. The <i><WAIT...></i> message is displayed. Starting the DMA and interrupt controller test next.
60h	The DMA page register test passed. Performing the DMA Controller 1 base register test next.
62h	The DMA controller 1 base register test passed. Performing the DMA controller 2 base register test next.
65h	The DMA controller 2 base register test passed. Programming DMA controllers 1 and 2 next.
66h	Completed programming DMA controllers 1 and 2. Initializing the 8259 interrupt controller next.
67h	Completed 8259 interrupt controller initialization.
7Fh	Extended NMI source enabling is in progress.
80h	The keyboard test has started. Clearing the output buffer and checking for stuck keys. Issuing the keyboard reset command next.
81h	A keyboard reset error or stuck key was found. Issuing the keyboard controller interface test command next.
82h	The keyboard controller interface test completed. Writing the command byte and initializing the circular buffer next.
83h	The command byte was written and global data initialization has completed. Checking for a locked key next.
84h	Locked key checking is over. Checking for a memory size mismatch with CMOS RAM data next.
85h	The memory size check is done. Displaying a soft error and checking for a password or bypassing WINBIOS Setup next.
86h	The password was checked. Performing any required programming before WINBIOS Setup next.
87h	The programming before WINBIOS Setup has completed. Uncompressing the WINBIOS Setup code and

Checkpoint	Code Description
	executing the AMIBIOS Setup or WINBIOS Setup utility next.
88h	Returned from WINBIOS Setup and cleared the screen. Performing any necessary programming after WINBIOS Setup next.
89h	The programming after WINBIOS Setup has completed. Displaying the power on screen message next.
8Bh	The first screen message has been displayed. The <WAIT...> message is displayed. Performing the PS/2 mouse check and extended BIOS data area allocation check next.
8Ch	Programming the WINBIOS Setup options next.
8Dh	The WINBIOS Setup options are programmed. Resetting the hard disk controller next.
8Fh	The hard disk controller has been reset. Configuring the floppy drive controller next.
91h	The floppy drive controller has been configured. Configuring the hard disk drive controller next.
95h	Initializing the bus option ROMs from C800 next. See the last page of this chapter for additional information.
96h	Initializing before passing control to the adaptor ROM at C800.
97h	Initialization before the C800 adaptor ROM gains control has completed. The adaptor ROM check is next.
98h	The adaptor ROM had control and has now returned control to BIOS POST. Performing any required processing after the option ROM returned control.
99h	Any initialization required after the option ROM test has completed. Configuring the timer data area and printer base address next.
9Ah	Set the timer and printer base addresses. Setting the RS-232 base address next.
9Bh	Returned after setting the RS-232 base address. Performing any required initialization before the coprocessor test next.
9Ch	Required initialization before the Coprocessor test is over. Initializing the coprocessor next.
9Dh	Coprocessor initialized. Performing any required initialization after the Coprocessor test next.
9Eh	Initialization after the Coprocessor test is complete. Checking the extended keyboard, keyboard ID, and

Checkpoint	Code Description
	Num Lock key next. Issuing the keyboard ID command next.
A2h	Displaying any soft errors next.
A3h	The soft error display has completed. Setting the keyboard typematic rate next.
A4h	The keyboard typematic rate is set. Programming the memory wait states next.
A5h	Memory wait state programming is over. Clearing the screen and enabling parity and the NMI next.
A7h	NMI and parity enabled. Performing any initialization required before passing control to the adaptor ROM at E000 next.
A8h	Initialization before passing control to the adaptor ROM at E000h completed. Passing control to the adaptor ROM at E000h next.
A9h	Returned from adaptor ROM at E000h control. Performing any initialization required after the E000 option ROM had control next.
Aah	Initialization after E000 option ROM control has completed. Displaying the system configuration next.
Abh	Uncompressing the DMI data and executing DMI POST initialization next.
B0h	The system configuration is displayed.
B1h	Copying any code to specific areas.
00h	Code copying to specific areas is done. Passing control to INT 19h boot loader next.

B-4 Bus Checkpoint Codes

The system BIOS passes control to different buses at the following checkpoints:

Checkpoint	Code Description
2Ah	Initializing the different bus system, static, and output devices, if present.
38h	Initialized bus input, IPL, and general devices, if present.
39h	Displaying bus initialization error messages, if any.
95h	Initializing bus adaptor ROMs from C8000h through D8000h.

Additional Bus Checkpoints

While control is inside the different bus routines, additional checkpoints are output to I/O port address 0080h as word to identify the routines being executed. These are word checkpoints.

The low byte of checkpoint is the system BIOS checkpoint where control is passed to the different bus routines.

The high byte of checkpoint indicates that the routine is being executed in different buses.

High Byte

The high byte of these checkpoints includes the following information:

Bits 7-4	Description
0000 Function 0.	Disable all devices on the bus
0001 Function 1.	Initialize static devices on the bus
0010 Function 2.	Initialize output devices on the bus
0011 Function 3.	Initialize input devices on the bus
0100 Function 4.	Initialize IPL devices on the bus
0101 Function 5.	Initiate general devices on the bus
0110 Function 6.	Initialize error reporting on the bus
0111 Function 7.	Initialize add-on ROMs for all buses

Notes

Appendix C

System Specifications

Processors

Single or dual Pentium® III FCPGA 500 MHz-1.40 GHz processors (server version) with a 512K L2 cache at front bus speeds of 133 and 100 MHz.

Note: Please refer to the support section of our web site for a complete listing of supported processors. (<http://www.supermicro.com/TechSupport.htm>)

Chipset

ServerWorks ServerSet III HE Super Light

BIOS

4 Mb AMI® Flash ROM

APM 1.2, DMI 2.1, PCI 2.2, ACPI 1.0, Plug and Play (PnP)

Memory Capacity

Four 168-pin DIMM sockets supporting up to 4 GB registered ECC SDRAM

Notes: The memory speed must match the front side bus speed being used (both 133 or 100 MHz).

The DIMM slots on the P3TDER+ are set at a 25° angle to provide a low vertical profile.

Memory modules should be installed in pairs (first in the two slots of Bank0, then in both slots of Bank 1, if needed).

DIMM Sizes

128 MB / 256 MB / 512 MB / 1 GB PC100/133 SDRAM modules supported

SCSI Controller

Adaptec AIC-7899 for dual channel Ultra160 SCSI

SCSI SCA Backplane Controller

QLogic GEM318 controller for SAF-TE compliance (optional)

SCSI Drive Bays

Two (2) drive bays to house two (2) standard 1" 80-pin SCA SCSI drives

Peripheral Bays

One (1) 3.5" floppy drive
One (1) slim CD-ROM drive
Two (2) 3.5 x 1" drive bays (for SCSI drives)

Expansion Slots

One (1) 64-bit, 66 MHz PCI slots

Power Supply

Type: 1 x 250W with +3.3V, +5V, +12V, -5V and -12V main DC outputs and a 5V standby output.
Input Voltage: 100-240VAC (w/ \pm 10% tolerance (units are autoswitching capable)
Fans: Two 4-cm ball bearing fans

Operating Environment

Operating Temperature Range: 0 to 40 degrees C
Humidity Range: 5-90%, non-condensing
Safety Regulations: CE, UL/CUL, EMC
EMI: FCC part 15, CISPR 22 (EN 55022)
System: One (1) 10-cm blower fan
Max. current = 0.63 amps
Fan speed: 3800 rpm

Form Factor

P3TDER+ motherboard: Extended ATX (12.05 x 11.475 in.)
SC810 chassis: 1U rackmount

Operating Systems Supported

Windows NT, Windows 2000, Solaris, Netware, SCO UNIX and Linux

Dimensions

16.7 x 1.7 x 22 in.; 424 x 43 x 556 mm (W x H x D)

Weight

Net (Bare Bone): ~17.6 lbs. (8 kg.)
Gross (Bare Bone): ~22 lbs. (10 kg.)