

AS1010P-8  
AS1010P-8R  
AS1010P-T  
AS1010P-TR

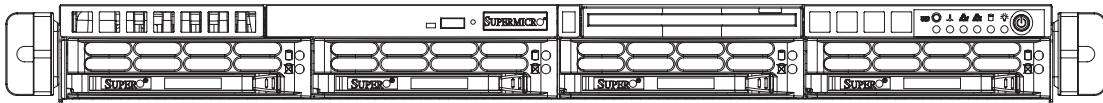

USER'S MANUAL

1.0

---

The information in this User's Manual has been carefully reviewed and is believed to be accurate. The vendor assumes no responsibility for any inaccuracies that may be contained in this document, makes no commitment to update or to keep current the information in this manual, or to notify any person or organization of the updates.

The manufacturer reserves the right to make changes to the product described in this manual at any time and without notice. This product, including software, if any, and documentation may not, in whole or in part, be copied, photocopied, reproduced, translated or reduced to any medium or machine without prior written consent.

IN NO EVENT WILL THE MANUFACTURER BE LIABLE FOR DIRECT, INDIRECT, SPECIAL, INCIDENTAL, OR CONSEQUENTIAL DAMAGES ARISING FROM THE USE OR INABILITY TO USE THIS PRODUCT OR DOCUMENTATION, EVEN IF ADVISED OF THE POSSIBILITY OF SUCH DAMAGES. IN PARTICULAR, THE VENDOR SHALL NOT HAVE LIABILITY FOR ANY HARDWARE, SOFTWARE, OR DATA STORED OR USED WITH THE PRODUCT, INCLUDING THE COSTS OF REPAIRING, REPLACING, INTEGRATING, INSTALLING OR RECOVERING SUCH HARDWARE, SOFTWARE, OR DATA.

Any disputes arising between manufacturer and customer shall be governed by the laws of Santa Clara County in the State of California, USA. The State of California, County of Santa Clara shall be the exclusive venue for the resolution of any such disputes. The manufacturer's total liability for all claims will not exceed the price paid for the hardware product.

---

Manual Revision 1.0

Release Date: January 6, 2006

Unless you request and receive written permission from the manufacturer, you may not copy any part of this document.

Information in this document is subject to change without notice. Other products and companies referred to herein are trademarks or registered trademarks of their respective companies or mark holders.

Copyright © 2006  
All rights reserved.

**Printed in the United States of America**

# Preface

## About This Manual

This manual is written for professional system integrators and PC technicians. It provides information for the installation and use of the AS1010P-8(R)/1010P-T(R). Installation and maintenance should be performed by experienced technicians only.

The 1010P-8(R)/1010P-T(R) is a high-end server based on the SC816S-(R)400/SC816T-(R)400 1U rackmount chassis and the H8SSP-8/H8SSP-i, a single processor serverboard that supports AMD 100 series processors and up to 16 GB of registered ECC DDR333/266 or up to 8 GB of registered ECC DDR400 SDRAM.

## Manual Organization

### Chapter 1: Introduction

The first chapter provides a checklist of the main components included with the server system and describes the main features of the H8SSP-8/H8SSP-i serverboard and the SC816S-(R)400/SC816T-(R)400 chassis, which comprise the AS1010P-8(R)/1010P-T(R).

### Chapter 2: Server Installation

This chapter describes the steps necessary to install the 1010P-8(R)/1010P-T(R) into a rack and check out the server configuration prior to powering up the system. If your server was ordered without processor and memory components, this chapter will refer you to the appropriate sections of the manual for their installation.

### Chapter 3: System Interface

Refer here for details on the system interface, which includes the functions and information provided by the control panel on the chassis as well as other LEDs located throughout the system.

## **Chapter 4: System Safety**

You should thoroughly familiarize yourself with this chapter for a general overview of safety precautions that should be followed when installing and servicing the 1010P-8(R)/1010P-T(R).

## **Chapter 5: Advanced Serverboard Setup**

Chapter 5 provides detailed information on the H8SSP-8/H8SSP-i serverboard, including the locations and functions of connections, headers and jumpers. Refer to this chapter when adding or removing processors or main memory and when reconfiguring the serverboard.

## **Chapter 6: Advanced Chassis Setup**

Refer to Chapter 6 for detailed information on the SC816S-(R)400/SC816T-(R)400 server chassis. You should follow the procedures given in this chapter when installing, removing or reconfiguring SCSI/SATA or peripheral drives and when replacing system power supply modules and cooling fans.

## **Chapter 7: BIOS**

The BIOS chapter includes an introduction to BIOS and provides detailed information on running the CMOS Setup Utility.

## **Appendix A: BIOS Error Beep Codes**

## **Appendix B: BIOS POST Checkpoint Codes**

## **Appendix C: System Specifications**

## Notes

# Table of Contents

## Preface

About This Manual .....	iii
Manual Organization .....	iii

## Chapter 1: Introduction

1-1 Overview .....	1-1
1-2 Serverboard Features .....	1-2
1-3 Server Chassis Features .....	1-3

## Chapter 2: Server Installation

2-1 Overview .....	2-1
2-2 Unpacking the System .....	2-1
2-3 Preparing for Setup .....	2-1
Choosing a Setup Location .....	2-2
Rack Precautions .....	2-2
Server Precautions .....	2-2
Rack Mounting Considerations .....	2-3
2-4 Installing the System into a Rack .....	2-4
2-5 Checking the Serverboard Setup .....	2-8
2-6 Checking the Drive Bay Setup .....	2-10

## Chapter 3: System Interface

3-1 Overview .....	3-1
3-2 Control Panel Buttons .....	3-1
UID .....	3-1
Power .....	3-1
3-3 Control Panel LEDs .....	3-2
UID .....	3-2
Overheat/Fan Fail .....	3-2
NIC2 .....	3-2
NIC1 .....	3-2
HDD .....	3-3
Power .....	3-3
3-4 SCSI/SATA Drive Carrier LEDs .....	3-3

---

**Chapter 4: System Safety**

4-1	Electrical Safety Precautions .....	4-1
4-2	General Safety Precautions .....	4-2
4-3	ESD Precautions .....	4-3
4-4	Operating Precautions .....	4-4

**Chapter 5: Advanced Serverboard Setup**

5-1	Handling the Serverboard .....	5-1
5-2	Mounting the Serverboard into a Chassis .....	5-2
5-3	Processor and Heatsink Installation .....	5-2
5-4	Connecting Cables .....	5-5
	Connecting Data Cables .....	5-5
	Connecting Power Cables .....	5-5
	Connecting the Control Panel .....	5-6
5-5	I/O Ports .....	5-6
5-6	Installing Memory .....	5-7
5-7	Adding PCI Cards .....	5-9
5-8	Serverboard Details .....	5-10
	H8SSP-8/H8SSP-i Layout .....	5-10
	H8SSP-8/H8SSP-i Quick Reference .....	5-11
5-9	Connector Definitions .....	5-12
	Primary ATX Power Connector .....	5-12
	Secondary Power Connector .....	5-12
	NMI Button .....	5-12
	Power LED .....	5-12
	HDD LED .....	5-13
	NIC1 LED .....	5-13
	NIC2 LED .....	5-13
	Overheat/Fan Fail LED .....	5-13
	Power Fail LED .....	5-14
	UID Button & LED .....	5-14
	Power Button .....	5-14
	USB0/1 Ports .....	5-14
	USB2/3 Headers .....	5-15
	Serial Ports .....	5-15
	Fan Headers .....	5-15
	Chassis Intrusion .....	5-15
	Power LED/Speaker .....	5-16
	ATX PS/2 Keyboard and PS/2 Mouse Ports .....	5-16

---

JLAN1/2 (Ethernet Ports) .....	5-16
IPMB Header .....	5-16
DOC Power Header .....	5-17
Wake-On-Ring .....	5-17
Wake-On-LAN .....	5-17
5-10 Jumper Settings .....	5-18
Explanation of Jumpers .....	5-18
CMOS Clear .....	5-18
PCI-X#1/#2 Frequency Select .....	5-19
Onboard Speaker Enable/Disable .....	5-19
Watch Dog .....	5-19
SCSI Controller Enable/Disable .....	5-20
SCSI Termination Enable/Disable .....	5-20
VGA Enable/Disable .....	5-20
Power Force On .....	5-20
I <sup>2</sup> C to PCI Enable/Disable .....	5-21
DOC IDE Bus Select .....	5-21
5-11 Onboard Indicators .....	5-21
JLAN1/2 LEDs .....	5-21
+3.3V Power LED .....	5-21
SCSI Activity LEDs .....	5-22
POST Code LEDs .....	5-22
5-12 Floppy, IDE, SCSI and SATA Drive Connections .....	5-23
Floppy Connector .....	5-23
IDE Connector .....	5-24
SCSI Connectors .....	5-25
SATA Connector .....	5-26

## **Chapter 6: Advanced Chassis Setup**

6-1 Static-Sensitive Devices .....	6-1
6-2 Control Panel .....	6-2
6-3 System Fans .....	6-3
System Fan Failure .....	6-3
Replacing System Cooling Fans .....	6-3
6-4 Drive Bay Installation/Removal .....	6-4
Accessing the Drive Bays .....	6-4
SCSI/SATA Drive Installation .....	6-5
DVD/CD-ROM and Floppy Drive Installation .....	6-7

---

---

6-5	Power Supply .....	6-8
	1010P-8R/1010P-TR: Power Supply Failure .....	6-8
	1010P-8R/1010P-TR: Removing/Replacing the Power Supply .....	6-8
	1010P-8/1010P-T: Power Supply Failure .....	6-9
	1010P-8/1010P-T: Removing/Replacing the Power Supply .....	6-9

## **Chapter 7: BIOS**

7-1	Introduction .....	7-1
7-2	Main Menu .....	7-2
7-3	Advanced Settings Menu .....	7-2
7-4	Boot Menu .....	7-15
7-5	Security Menu .....	7-17
7-6	Exit Menu .....	7-17

## **Appendices:**

Appendix A: BIOS Error Beep Codes .....	A-1
Appendix B: BIOS POST Checkpoint Codes .....	B-1
Appendix C: System Specifications .....	C-1

# Notes

# Chapter 1

## Introduction

### 1-1 Overview

The AS1010P-8(R)/1010P-T(R) is a high-end server comprised of two main subsystems: the SC816S-(R)400/SC816T-(R)400 1U server chassis and the H8SSP-8/H8SSP-i single processor serverboard. Please refer to our web site for information on operating systems that have been certified for use with the 1010P-8(R)/1010P-T(R).

In addition to the serverboard and chassis, various hardware components have been included with the 1010P-8(R)/1010P-T(R), as listed below:

- One (1) slim floppy drive [FPD-TEAC-S(B)]
- One (1) slim 8x DVD/24x CD-ROM drive [DVM-PNSC-824(B)]
- Three (3) 4-cm counter-rotating chassis cooling fans (FAN-0085)
- One (1) front control panel cable
- One (1) rackmount kit (CSE-PT51)
- One (1) riser card (CSE-RR1U-X) for PCI-X add-on card
- One (1) riser card (CSE-RR1U-XR) for PCI-X add-on card
- One (1) riser card (CSE-RR1U-EL) for PCI-E add-on card
- One (1) riser card (CSE-RR1U-ER) for PCI-E add-on card
- SCSI Accessories (1010P-8/1010P-8R only)
  - Four (4) SCA SCSI hard drive carriers (CSE-PT-39(B))
  - One (1) SCSI backplane (CSE-SCA-814S)
  - One (1) Ultra320 SCSI cable (CBL-0063)
- SATA Accessories (1010P-T/1010P-TR only)
  - Four (4) SATA hard drive carriers [CSE-PT-39(B)]
  - One (1) SATA backplane (CSE-SAS-814)
  - One (1) SATA cable (CBL-0096-L)

- One (1) passive heatsink for 1U systems (optional, SNK-P0012)
- One (1) CD containing drivers and utilities

**Note:** (B) indicates the item is available in black.

## 1-2 Serverboard Features

At the heart of the 1010P-8(R)/1010P-T(R) lies the H8SSP-8/H8SSP-i, a single processor serverboard based on the ServerWorks HT-2000/1000 chipset. Below are the main features of the H8SSP-8/H8SSP-i (see Figure 1-1 for a block diagram of the chipset).

### Processors

The H8SSP-8/H8SSP-i supports a single AMD Opteron 200 series 64-bit processor in a 940-pin microPGA ZIF socket.

### Memory

The H8SSP-8/H8SSP-i has four 184-pin DIMM sockets that can support up to 16 GB of registered ECC DDR333/266 or up to 8 GB of registered ECC DDR400 SDRAM. Memory can be installed in either a single or a dual channel (interleaved) configuration, which requires modules of the same size and speed to be installed in pairs. Please refer to Chapter 5 for details on installing memory.

### SCSI Subsystem

The H8SSP-8 (only) includes onboard Adaptec AIC-7902W dual-channel SCSI controller, which supports four 80-pin SCA Ultra320 SCSI hard drives (SCA = Single Connection Attachment). The SCSI drives are connected to a backplane that provides power, bus termination and configuration settings. The SCSI drives are hot-swappable units.

### Serial ATA Subsystem

The H8SSP-8/H8SSP-i includes a SATA controller, which is integrated into the ServerWorks HT-1000. This controller supports four SATA hard drives. The SATA drives are connected to a backplane that provides power, bus termination and configuration settings. The SATA drives are hot-swappable units.

## Onboard Controllers/Ports

One floppy drive controller and a single-channel ATA/100 controller are provided to support up to two IDE hard drives or ATAPI devices. The color-coded I/O ports include one COM port, a VGA (monitor) port, two USB 2.0 ports, PS/2 mouse and keyboard ports and two gigabit Ethernet ports. An external SCSI port is also included on the H8SSP-8.

## ATI Graphics Controller

The H8SSP-8/H8SSP-i features an integrated ATI video controller based on the Rage XL graphics chip. Rage XL fully supports sideband addressing and AGP texturing.

## Other Features

Other onboard features that promote system health include onboard voltage monitors, a chassis intrusion header, auto-switching voltage regulators, chassis and CPU overheat sensors, virus protection and BIOS rescue.

## 1-3 Server Chassis Features

The 1010P-8(R)/1010P-T(R) is built upon the SC816S-(R)400/SC816T-(R)400 1U server chassis (1010P-8 = SC816S-400, 1010P-8R = SC816S-R400, 1010P-T = SC816T-400, 1010P-TR = SC816T-R400). The following is a general outline of the main features of the SC816S-(R)400/SC816T-(R)400 chassis.

### System Power

The 1010P-8 and 1010P-T feature a single 400W cold-swap power supply. Power must be removed from the system before servicing or replacing the power supply.

The 1010P-8R and 1010P-TR feature a redundant 400W hot-swap power supply. Power does not need to be removed from the system before servicing or replacing one of the two power supply modules.

### SCSI Subsystem

The SC816S-400/SC816S-R400 chassis was designed to support four SCSI hard drives, which are hot-swappable units.

**Note:** The operating system you use must have RAID support to enable the hot-swap capability of the SCSI drives.

## Serial ATA Subsystem

For the 1010P-T and 1010P-TR, the SC816T-400/SC816T-R400 chassis was designed to support four Serial ATA hard drives, which are hot-swappable units. RAID 0 and RAID 1 levels are supported.

**Note:** The system's operating system must have RAID support to enable the hot-swap capability of the Serial ATA drives.

## PCI Expansion Slots

The 1010P-8(R)/1010P-T(R) accommodates the use of one standard size 133 MHz PCI-X or PCI-Express x8 add-on card and one low profile 100 MHz PCI-X or PCI-Express x8 add-on card (all with riser cards). See Section 5-6 for details.

## Front Control Panel

The SC816S-(R)400/SC816T-(R)400's control panel provides you with system monitoring and control. LEDs indicate UID, system power, HDD activity, network activity (2) and overheat/fan failure. A main power button and a UID button are also included.

## I/O Backplane

Ports on the I/O backplane include one COM port, a VGA port, two USB ports, PS/2 mouse and keyboard ports, two gigabit Ethernet ports and a UID button/LED. An external SCSI port is also included on the AS1010P-8/1010P-8R server.

## Cooling System

The SC816S-(R)400/SC816T-(R)400 chassis has an innovative cooling design that features three sets of 4-cm counter-rotating fans located in the middle section of the chassis. There is a "Fan Speed Control Mode" setting in BIOS (see Chapter 7) that allows chassis fan speed to be determined by system temperature [recommended setting is "3-pin (Server)"]. The power supply module(s) also includes a cooling fan.

**Figure 1-1. Intel HT-2000/1000 Chipset:  
System Block Diagram**

Note: This is a general block diagram. Please see Chapter 5 for details.

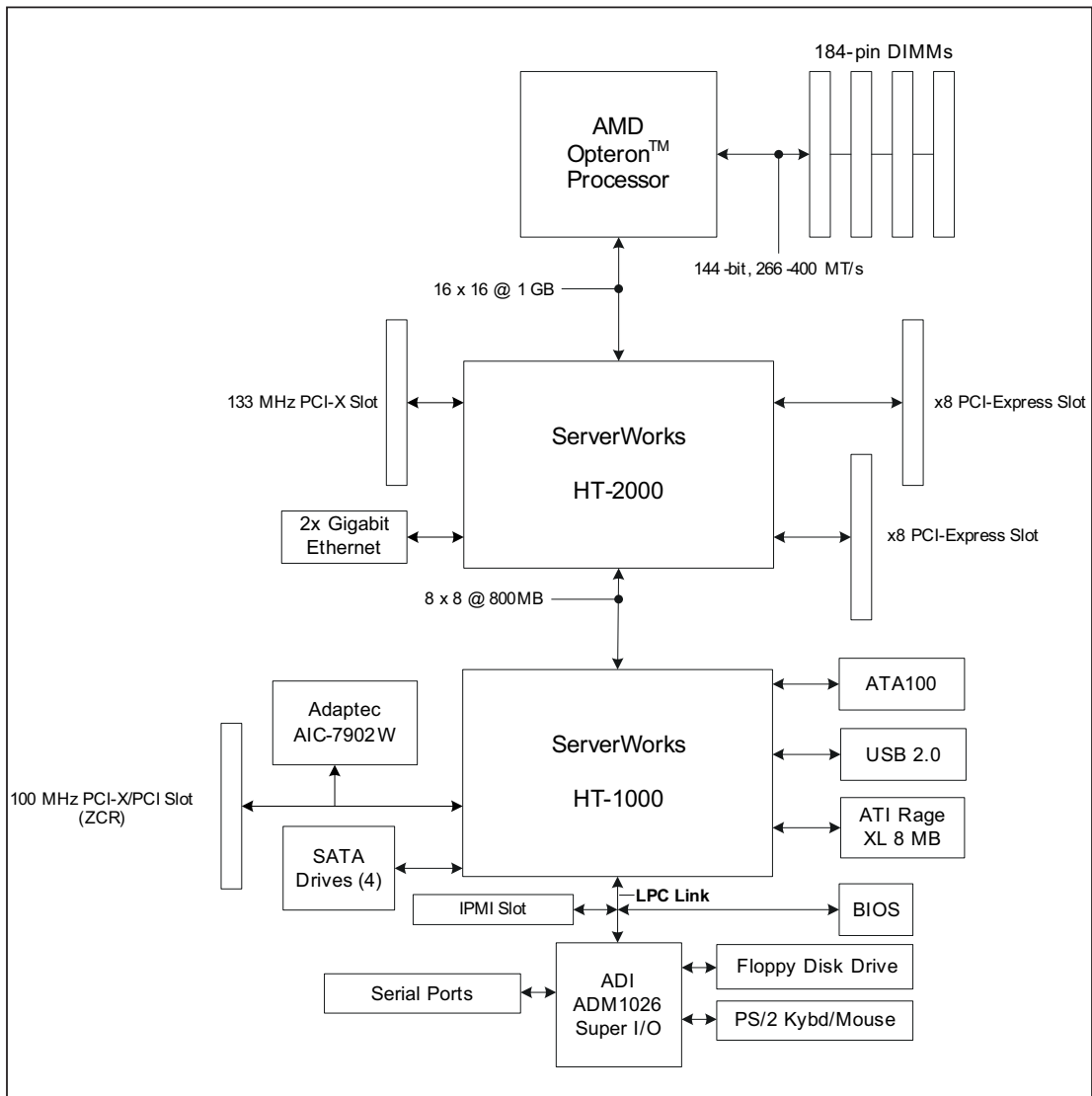

# Notes

# Chapter 2

## Server Installation

### 2-1 Overview

This chapter provides a quick setup checklist to get your 1010P-8(R)/1010P-T(R) up and running. Following these steps in the order given should enable you to have the system operational within a minimum amount of time. This quick setup assumes that your system has come to you with the processors and memory preinstalled. If your system is not already fully integrated with a serverboard, processors, system memory etc., please turn to the chapter or section noted in each step for details on installing specific components.

### 2-2 Unpacking the System

You should inspect the box the 1010P-8(R)/1010P-T(R) was shipped in and note if it was damaged in any way. If the server itself shows damage you should file a damage claim with the carrier who delivered it.

Decide on a suitable location for the rack unit that will hold the 1010P-8(R)/1010P-T(R). It should be situated in a clean, dust-free area that is well ventilated. Avoid areas where heat, electrical noise and electromagnetic fields are generated. You will also need it placed near a grounded power outlet. Be sure to read the Rack and Server Precautions in the next section.

### 2-3 Preparing for Setup

The box the 1010P-8(R)/1010P-T(R) was shipped in should include two sets of rail assemblies, two rail mounting brackets and the mounting screws you will need to install the system into the rack. Follow the steps in the order given to complete the installation process in a minimum amount of time. Please read this section in its entirety before you begin the installation procedure outlined in the sections that follow.

## Choosing a Setup Location

- Leave enough clearance in front of the rack to enable you to open the front door completely (~25 inches).
- Leave approximately 30 inches of clearance in the back of the rack to allow for sufficient airflow and ease in servicing.
- This product is for installation only in a Restricted Access Location (dedicated equipment rooms, service closets and the like).



### Warnings and Precautions!



## Rack Precautions

- Ensure that the leveling jacks on the bottom of the rack are fully extended to the floor with the full weight of the rack resting on them.
- In single rack installation, stabilizers should be attached to the rack.
- In multiple rack installations, the racks should be coupled together.
- Always make sure the rack is stable before extending a component from the rack.
- You should extend only one component at a time - extending two or more simultaneously may cause the rack to become unstable.

## Server Precautions

- Review the electrical and general safety precautions in Chapter 4.
- Determine the placement of each component in the rack *before* you install the rails.
- Install the heaviest server components on the bottom of the rack first, and then work up.
- Use a regulating uninterruptible power supply (UPS) to protect the server from power surges, voltage spikes and to keep your system operating in case of a power failure.
- Allow the hot plug SCSI/SATA drives and power supply modules to cool before touching them.
- Always keep the rack's front door and all panels and components on the servers closed when not servicing to maintain proper cooling.

## **Rack Mounting Considerations**

### **Ambient Operating Temperature**

If installed in a closed or multi-unit rack assembly, the ambient operating temperature of the rack environment may be greater than the ambient temperature of the room. Therefore, consideration should be given to installing the equipment in an environment compatible with the manufacturer's maximum rated ambient temperature (T<sub>mra</sub>).

### **Reduced Airflow**

Equipment should be mounted into a rack so that the amount of airflow required for safe operation is not compromised.

### **Mechanical Loading**

Equipment should be mounted into a rack so that a hazardous condition does not arise due to uneven mechanical loading.

### **Circuit Overloading**

Consideration should be given to the connection of the equipment to the power supply circuitry and the effect that any possible overloading of circuits might have on overcurrent protection and power supply wiring. Appropriate consideration of equipment nameplate ratings should be used when addressing this concern.

### **Reliable Ground**

A reliable ground must be maintained at all times. To ensure this, the rack itself should be grounded. Particular attention should be given to power supply connections other than the direct connections to the branch circuit (i.e. the use of power strips, etc.).

## 2-4 Installing the System into a Rack

This section provides information on installing the 1010P-8(R)/1010P-T(R) into a rack unit with the rack rails provided. If the system has already been mounted into a rack, you can skip ahead to Sections 2-5 and 2-6. There are a variety of rack units on the market, which may mean the assembly procedure will differ slightly. You should also refer to the installation instructions that came with the rack unit you are using.

### Identifying the Sections of the Rack Rails

You should have received two rack rail assemblies in the rack mounting kit. Each assembly consists of two sections: an inner fixed chassis rail that secures directly to the server chassis and an outer fixed rack rail that secures directly to the rack itself (see Figure 2-1). Two pairs of short brackets to be used on the front side of the outer rails are also included.

### Installing the Inner Rails

Both the left and right side inner rails have been pre-attached to the chassis. Proceed to the next step. A

**Figure 2-1. Identifying the Sections of the Rack Rails  
(right side rail shown)**

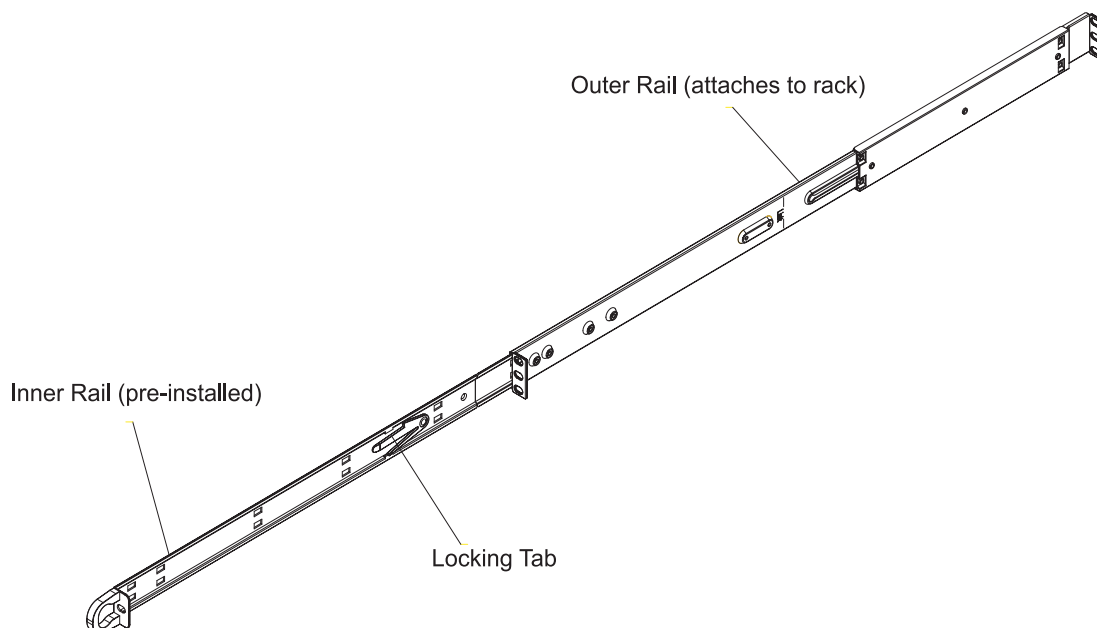

## Installing the Outer Rails

Begin by measuring the distance from the front rail to the rear rail of the rack. Attach a short bracket to the front side of the right outer rail and a long bracket to the rear side of the right outer rail. Adjust both the short and long brackets to the proper distance so that the rail can fit snugly into the rack. Secure the short bracket to the front side of the outer rail with two M4 screws and the long bracket to the rear side of the outer rail with three M4 screws. Repeat these steps for the left outer rail.

### Locking Tabs

Both chassis rails have a locking tab, which serves two functions. The first is to lock the server into place when installed and pushed fully into the rack, which is its normal position. Secondly, these tabs also lock the server in place when fully extended from the rack. This prevents the server from coming completely out of the rack when you pull it out for servicing.

Figure 2-2. Installing the Rack Rails

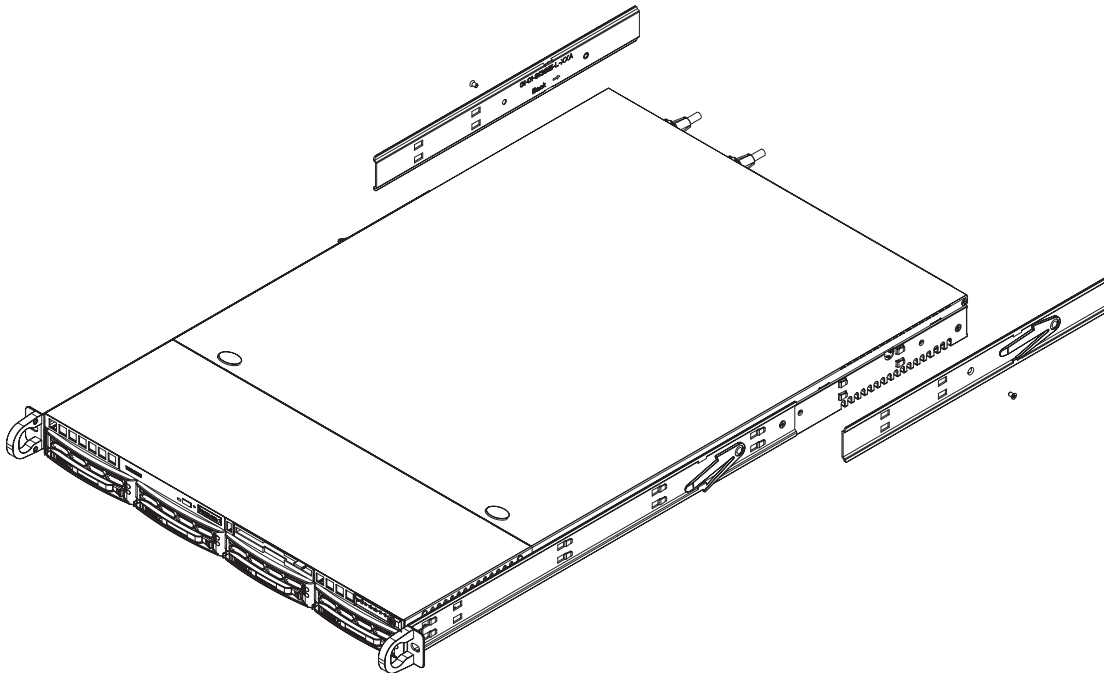

## Installing the Server into the Rack

You should now have rails attached to both the chassis and the rack unit. The next step is to install the server into the rack. Do this by lining up the rear of the chassis rails with the front of the rack rails. Slide the chassis rails into the rack rails, keeping the pressure even on both sides (you may have to depress the locking tabs when inserting). See Figure 2-3.

When the server has been pushed completely into the rack, you should hear the locking tabs "click".

**Figure 2-3. Installing the Server into a Rack**

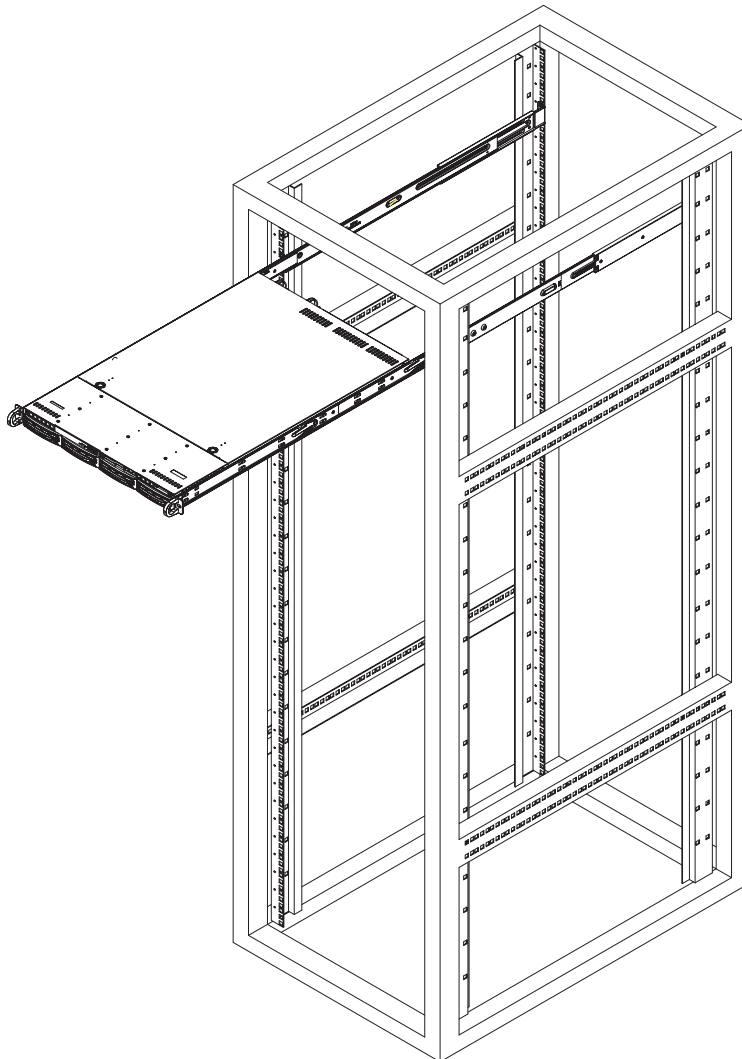

## Installing the Server into a Telco Rack

If you are installing the 1010P-8(R)/1010P-T(R) into a Telco type rack, follow the directions given on the previous pages for rack installation. The only difference in the installation procedure will be the positioning of the rack brackets to the rack. They should be spaced apart just enough to accommodate the width of the telco rack.

Figure 2-4. Installing the Server into a Telco Rack

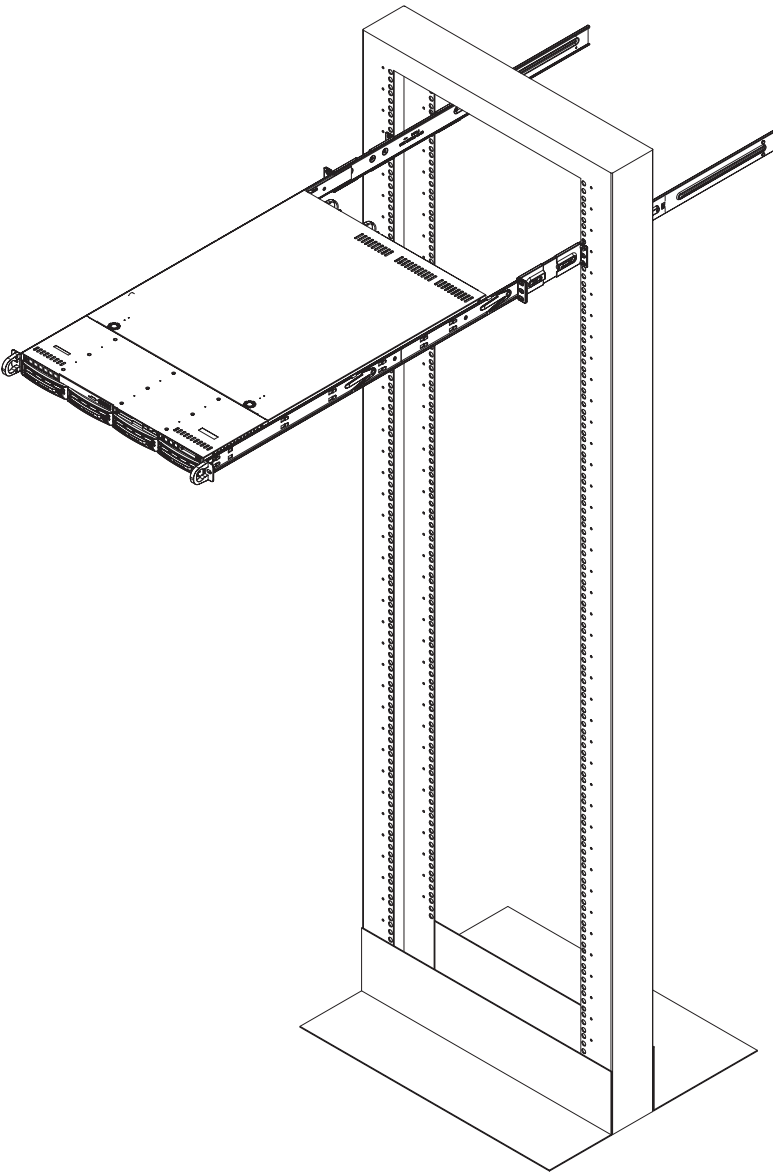

## 2-5 Checking the Serverboard Setup

After you install the 1010P-8(R)/1010P-T(R) in the rack, you will need to open the top cover to make sure the serverboard is properly installed and all the connections have been made.

### 1. Accessing the inside of the system (see Figure 2-5)

First, grasp the two handles on either side and pull the system straight out until it locks (you will hear a "click"). Next, depress the two buttons on the top of the chassis to release the top cover (1). Push the cover away from you (toward the rear of the chassis) until it stops (2). You can then lift the top cover from the chassis to gain full access to the inside of the server.

To remove the system from the rack completely, depress the locking tabs in the chassis rails (push the right-side tab down and the left-side tab up) to continue to pull the system out past the locked position.

### 2. Check the CPUs (processors)

You may have a processor already installed in the serverboard. The processor needs a heatsink installed. See Chapter 5 for instructions on processor and heatsink installation.

### 3. Check the system memory

Your server system may have come with system memory already installed. Make sure all DIMMs are fully seated in their slots. For details on adding system memory, refer to Chapter 5.

### 4. Installing add-on cards

If desired, you can install add-on cards to the system. See Chapter 5 for details on installing PCI add-on cards.

### 5. Check all cable connections and airflow

Make sure all power and data cables are properly connected and not blocking the chassis airflow. See Chapter 5 for details on cable connections.

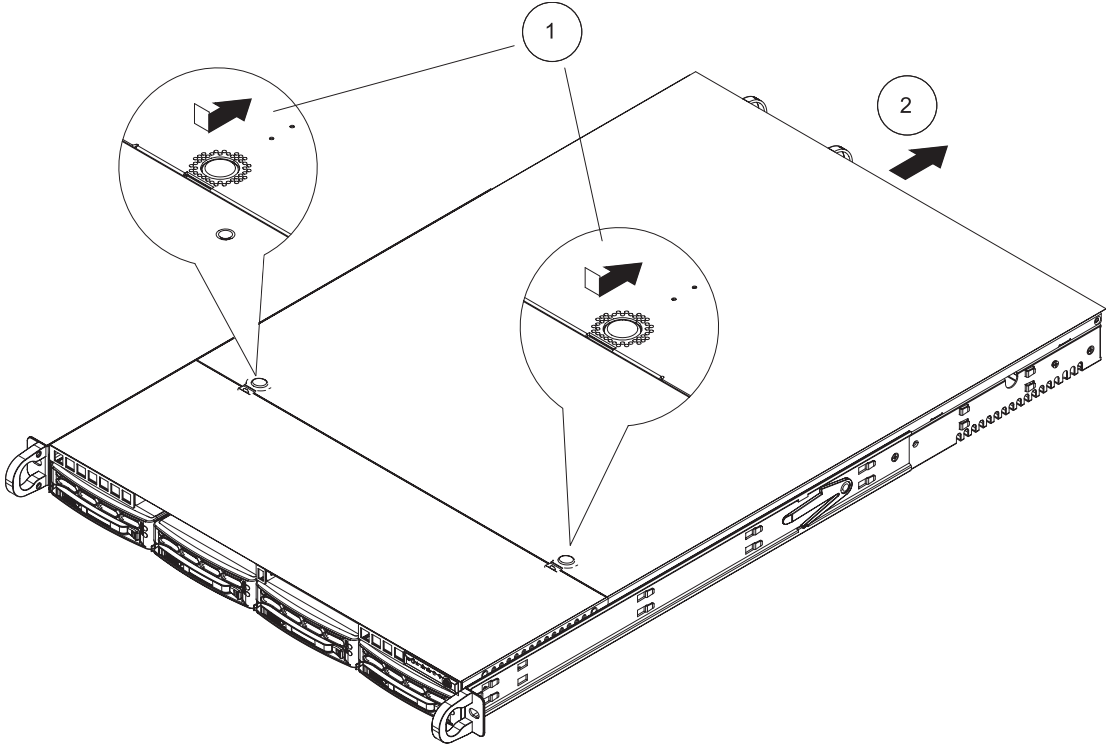

Figure 2-5. Accessing the Inside of the Server

## 2-6 Checking the Drive Bay Setup

Next, you should check to make sure the peripheral drives and the SCSI/SATA drives and backplane have been properly installed and all connections have been made.

### 1. Accessing the drive bays

All drives are accessible from the front of the server. For servicing the DVD-ROM and floppy drives, you will need to remove the top chassis cover. The SCSI/SATA disk drives can be installed and removed from the front of the chassis without removing the top chassis cover.

### 2. DVD-ROM and floppy disk drives

A slim DVD-ROM and floppy drive should be preinstalled in your server. Refer to Chapter 6 if you need to reinstall a DVD-ROM and/or floppy disk drive to the system.

### 3. Check the SCSI/SATA disk drives

Depending upon your system's configuration, your system may have one or more drives already installed. If you need to install SCSI/SATA drives, please refer to Chapter 6.

### 4. Check the airflow

Airflow is provided by three sets of 4-cm fans (each set of fans consists of two fans that are mounted back to back). The system component layout was carefully designed to direct sufficient cooling airflow to the components that generate the most heat. Note that all power and data cables have been routed in such a way that they do not block the airflow generated by the fans.

### 5. Supplying power to the system

The last thing you must do is to provide input power to the system. Plug the power cord(s) from the power supply module(s) into a high-quality power strip that offers protection from electrical noise and power surges. It is recommended that you use an uninterruptible power supply (UPS) source.

## Chapter 3

# System Interface

### 3-1 Overview

There are several LEDs on the chassis control panel as well as others on the SCSI/SATA drive carriers to keep you constantly informed of the overall status of the system as well as the activity and health of specific components. There are also two buttons on the chassis control panel. This chapter explains the meanings of all LED indicators and the appropriate response you may need to take.

### 3-2 Control Panel Buttons

There are two push-button buttons located on the front of the chassis. These are (in order from left to right) a UID button and a power on/off button.

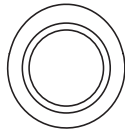

- **UID:** Depressing the UID (unit identifier) button illuminates an LED on both the front and rear of the chassis for easy system location in large stack configurations. The LED will remain on until the button is pushed a second time. Another UID button on the rear of the chassis serves the same function.



- **POWER:** This is the main power switch, which is used to apply or turn off the main system power. Turning off system power with this button removes the main power but keeps standby power supplied to the system.

### 3-3 Control Panel LEDs

The control panel located on the front of the SC816S-(R)400/SC816T-(R)400 chassis has six LEDs, which provide you with critical information related to different parts of the system. This section explains what each LED indicates when illuminated and any corrective action you may need to take.

#### UID

- **UID:** This LED turns on when either the front or the rear UID button is pushed. Pushing either button a second time will turn this LED off.



- **Overheat/Fan Fail:** When this LED flashes it indicates a fan failure. When on continuously (on and not flashing) it indicates an overheat condition, which may be caused by cables obstructing the airflow in the system or the ambient room temperature being too warm. Check the routing of the cables and make sure all fans are present and operating normally. You should also check to make sure that the chassis covers are installed. Finally, verify that the heatsinks are installed properly (see Chapter 5). This LED will remain flashing or on as long as the overheat condition exists.



- **NIC2:** Indicates network activity on GLAN2 when flashing.



- **NIC1:** Indicates network activity on GLAN1 when flashing.



- **HDD:** Indicates hard drive activity. On the AS1010P-8(R)/1010P-T(R) this light indicates SCSI and/or DVD-ROM drive activity when flashing.



- **Power:** Indicates power is being supplied to the system's power supply module(s). With the 1010P-8/1010P-T, this LED should always be green when the system is operating. On the 1010P-8R/1010P-TR, this LED turns amber in the event of a power supply failure or if a power supply cord is disconnected or loose.

### 3-4 SCSI/SATA Drive Carrier LEDs

**1010P-8/1010P-8R:** Each SCSI drive carrier has two LEDs.

- **Green:** When illuminated, the green LED on the front of the SCSI drive carrier indicates drive activity. A connection to the SCSI SCA backplane enables this LED to blink on and off when that particular drive is being accessed.
- **Red:** The SAF-TE compliant backplane activates the red LED to indicate a drive failure. If one of the SCSI drives fail, you should be notified by your system management software. Please refer to Chapter 6 for instructions on replacing failed SCSI drives.

**1010P-T/1010P-TR:** Each Serial ATA drive carrier has a green LED. When illuminated, this green LED (on the front of the Serial ATA drive carrier) indicates drive activity. A connection to the Serial ATA backplane enables this LED to blink on and off when that particular drive is being accessed. Please refer to Chapter 6 for instructions on replacing failed SATA drives.

**Note:** The second LED on the SATA carriers is not used.

## Notes

# Chapter 4

## System Safety

### 4-1 Electrical Safety Precautions



Basic electrical safety precautions should be followed to protect yourself from harm and the 1010P-8(R)/1010P-T(R) from damage:

- Be aware of the locations of the power on/off switch on the chassis as well as the room's emergency power-off switch, disconnection switch or electrical outlet. If an electrical accident occurs, you can then quickly remove power from the system.
- Do not work alone when working with high voltage components.
- Power should always be disconnected from the system when removing or installing main system components, such as the serverboard, memory modules and the DVD-ROM and floppy drives (not necessary for SCSI/SATA drives). When disconnecting power, you should first power down the system with the operating system and then unplug the power cords of all the power supply modules in the system.
- When working around exposed electrical circuits, another person who is familiar with the power-off controls should be nearby to switch off the power if necessary.
- Use only one hand when working with powered-on electrical equipment. This is to avoid making a complete circuit, which will cause electrical shock. Use extreme caution when using metal tools, which can easily damage any electrical components or circuit boards they come into contact with.
- Do not use mats designed to decrease electrostatic discharge as protection from electrical shock. Instead, use rubber mats that have been specifically designed as electrical insulators.

- The power supply power cord must include a grounding plug and must be plugged into grounded electrical outlets.
- Serverboard Battery: **CAUTION** - There is a danger of explosion if the onboard battery is installed upside down, which will reverse its polarities (see Figure 4-1). This battery must be replaced only with the same or an equivalent type recommended by the manufacturer. Dispose of used batteries according to the manufacturer's instructions.
- CD-ROM Laser: **CAUTION** - this server may have come equipped with a CD-ROM drive. To prevent direct exposure to the laser beam and hazardous radiation exposure, do not open the enclosure or use the unit in any unconventional way.

## 4-2 General Safety Precautions



Follow these rules to ensure general safety:

- Keep the area around the 1010P-8/1010P-8R clean and free of clutter.
- The 1010P-8(R)/1010P-T(R) weighs approximately 57(60) lbs (25.9/27.3 kg) when fully loaded. When lifting the system, two people at either end should lift slowly with their feet spread out to distribute the weight. Always keep your back straight and lift with your legs.
- Place the chassis top cover and any system components that have been removed away from the system or on a table so that they won't accidentally be stepped on.
- While working on the system, do not wear loose clothing such as neckties and unbuttoned shirt sleeves, which can come into contact with electrical circuits or be pulled into a cooling fan.
- Remove any jewelry or metal objects from your body, which are excellent metal conductors that can create short circuits and harm you if they come into contact with printed circuit boards or areas where power is present.
- After accessing the inside of the system, close the system back up and secure

it to the rack unit with the retention screws after ensuring that all connections have been made.

### 4-3 ESD Precautions



Electrostatic discharge (ESD) is generated by two objects with different electrical charges coming into contact with each other. An electrical discharge is created to neutralize this difference, which can damage electronic components and printed circuit boards. The following measures are generally sufficient to neutralize this difference before contact is made to protect your equipment from ESD:

- Use a grounded wrist strap designed to prevent static discharge.
- Keep all components and printed circuit boards (PCBs) in their antistatic bags until ready for use.
- Touch a grounded metal object before removing any board from its antistatic bag.
- Do not let components or PCBs come into contact with your clothing, which may retain a charge even if you are wearing a wrist strap.
- Handle a board by its edges only; do not touch its components, peripheral chips, memory modules or contacts.
- When handling chips or modules, avoid touching their pins.
- Put the serverboard and peripherals back into their antistatic bags when not in use.
- For grounding purposes, make sure your computer chassis provides excellent conductivity between the power supply, the case, the mounting fasteners and the serverboard.

## 4-4 Operating Precautions



Care must be taken to assure that the chassis cover is in place when the 1010P-8(R)/1010P-T(R) is operating to ensure proper cooling. Out of warranty damage to the 1010P-8(R)/1010P-T(R) system can occur if this practice is not strictly followed.

**Figure 4-1. Installing the Onboard Battery**

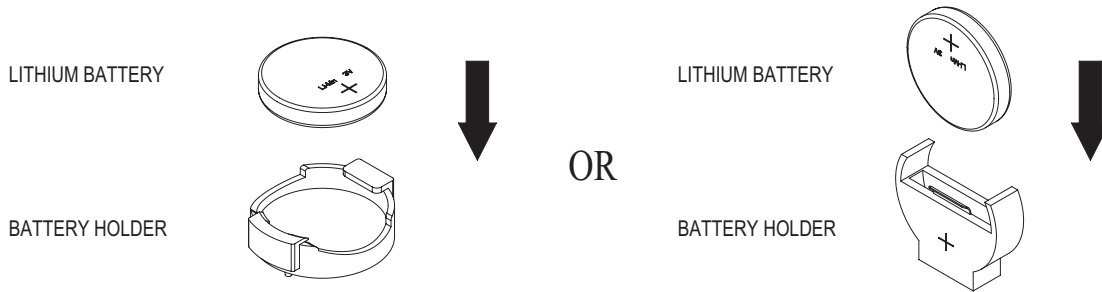

## Chapter 5

# Advanced Serverboard Setup

This chapter covers the steps required to install processors and heatsinks to the H8SSP-8 serverboard, connect the data and power cables and install add-on cards. All serverboard jumpers and connections are described and a layout and quick reference chart are included in this chapter. Remember to close the chassis completely when you have finished working on the serverboard to protect and cool the system sufficiently.

### 5-1 Handling the Serverboard

Static electrical discharge can damage electronic components. To prevent damage to printed circuit boards, it is important to handle them very carefully (see Chapter 4). Also note that the size and weight of the serverboard can cause it to bend if handled improperly, which may result in damage. To prevent the serverboard from bending, keep one hand under the center of the board to support it when handling. The following measures are generally sufficient to protect your equipment from static discharge.

#### Precautions

- Use a grounded wrist strap designed to prevent static discharge.
- Touch a grounded metal object before removing any board from its antistatic bag.
- Handle a board by its edges only; do not touch its components, peripheral chips, memory modules or gold contacts.
- When handling chips or modules, avoid touching their pins.
- Put the serverboard, add-on cards and peripherals back into their antistatic bags when not in use.

#### Unpacking

The serverboard is shipped in antistatic packaging to avoid static damage. When unpacking the board, make sure the person handling it is static protected.

## 5-2 Mounting the Serverboard into a Chassis

All serverboards and motherboards have standard mounting holes to fit different types of chassis. Make sure that the locations of all the mounting holes for both the serverboard and the chassis match. Although a chassis may have both plastic and metal mounting fasteners, metal ones are highly recommended because they ground the serverboard to the chassis. Make sure that the metal standoffs click in or are screwed in tightly.

### 1. Check the compatibility of the serverboard ports and the I/O shield

The H8SSP-8 serverboard requires a chassis that can support extended ATX boards of 16.235" x 11.24" in size, such as the SC816S/SC816T. Make sure that the I/O ports on the serverboard align with their respective holes in the I/O shield at the rear of the chassis.

### 2. Mounting the serverboard onto the mainboard tray in the chassis

Carefully mount the serverboard onto the mainboard tray by aligning the serverboard mounting holes with the raised metal standoffs in the tray. Insert screws into all the mounting holes in the serverboard that line up with the standoffs. Then use a screwdriver to secure the serverboard to the mainboard tray - tighten until just snug (if too tight you might strip the threads). Metal screws provide an electrical contact to the serverboard ground to provide a continuous ground for the system.

## 5-3 Processor and Heatsink Installation



*Exercise extreme caution when handling and installing the processor. Always connect the power cord last and always remove it before adding, removing or changing any hardware components.*

### CPU Backplates

One CPU backplate (BKT-0004) has been preinstalled to the underside of the serverboard. This backplate prevents the CPU area of the serverboard from bending and provides a base for attaching the CPU heatsinks.

## Installing the Processor

1. Lift the lever on CPU socket until it points straight up.

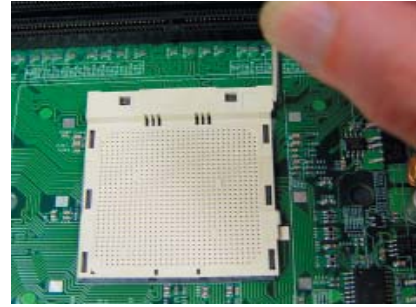

2. Use your thumb and your index finger to hold the CPU. Locate pin 1 on the CPU socket and pin 1 on the CPU. Both are marked with a triangle.

Triangles



3. Align pin 1 of the CPU with pin 1 of the socket. Once aligned, carefully place the CPU into the socket. *Do not drop the CPU on the socket, move the CPU horizontally or vertically or rub the CPU against the socket or against any pins of the socket, which may damage the CPU and/or the socket.*



4. With the CPU inserted into the socket, inspect the four corners of the socket to make sure that it is properly installed and flush with the socket.



5. Gently press the CPU socket lever down until it locks in the plastic tab.



## Installing the Heatsinks

To install the heatsink (SNK-P0012, optional), do not apply any thermal compound to the heatsink or CPU die - the proper amount has already been applied. Place the heatsink directly on the CPU so that the two mounting holes are aligned with those on the CPU backplate. Make sure the heatsink sits completely flat on the CPU - if not completely flat, the space between the two will degrade the heat dissipation function of the heatsink, which may cause the processor to overheat. Screw in the two screws until just snug (do not fully tighten), then finish by fully tightening both screws (see Figure 5-1).

**Figure 5-1. Installing Heatsinks**

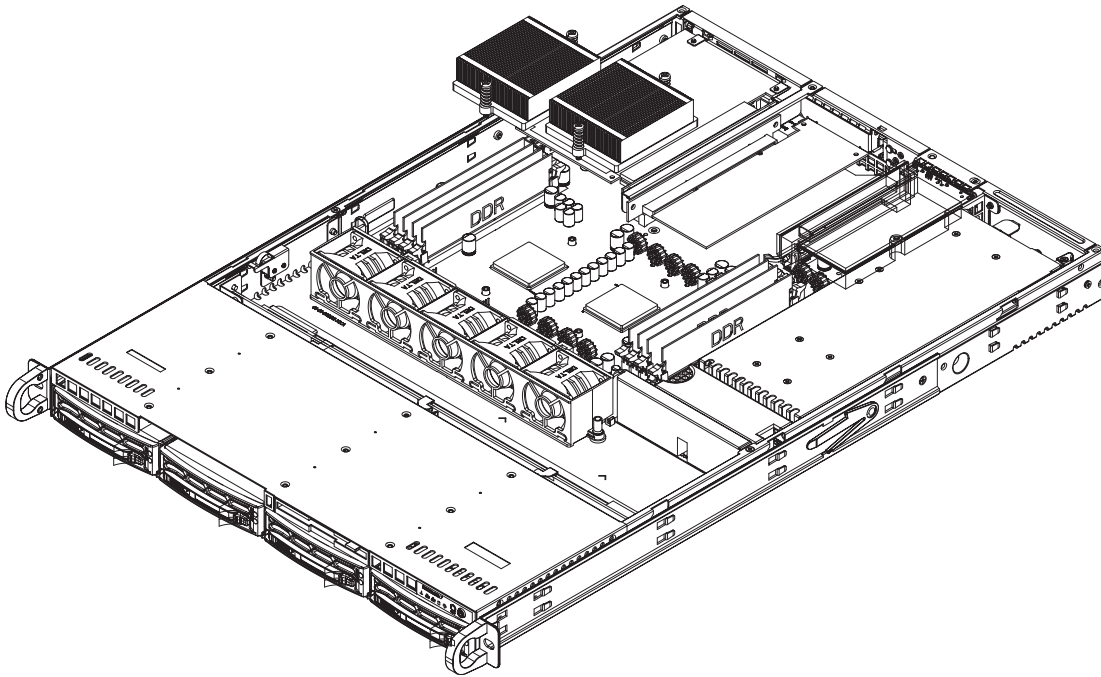

## 5-4 Connecting Cables

Now that the processors are installed, the next step is to connect the cables to the serverboard. These include the data (ribbon) cables for the peripherals and control panel and the power cables.

### Connecting Data Cables

The ribbon cables used to transfer data from the peripheral devices have been carefully routed in preconfigured systems to prevent them from blocking the flow of cooling air that moves through the system from front to back. If you need to disconnect any of these cables, you should take care to reroute them as they were originally after reconnecting them (make sure the red wires connect to the pin 1 locations). If you are configuring the system, keep the airflow in mind when routing the cables. The following data cables (with their serverboard connector locations noted) should be connected. See the serverboard layout diagram in this chapter for connector locations.

- DVD-ROM cable (JIDE#1)
- Floppy Drive cable (JFDD1)
- SCSI cables (JA1, JB1)
- Control Panel cable (JF1, see next page)

### Connecting Power Cables

The H8SSP-8/H8SSP-i has a 20-pin proprietary power supply connector designated "J43" for connection to the ATX power supply. Connect the appropriate connector from the power supply to the "ATX Power" connector to supply power to the serverboard. See the Connector Definitions section in this chapter for power connector pin definitions.

In addition, your power supply must be connected to the 10-pin Secondary ATX Power connection at J15.

## Connecting the Control Panel

JF1 contains header pins for various front control panel connectors. See Figure 5-2 for the pin locations of the various front control panel buttons and LED indicators and refer to section 5-9 for details. Note that even and odd numbered pins are on opposite sides of each header.

All JF1 wires have been bundled into single keyed ribbon cable to simplify their connection. The red wire in the ribbon cable plugs into pin 1 of JF1. Connect the other end of the cable to the Control Panel printed circuit board, located just behind the system status LEDs in the chassis.

See the Connector Definitions section in this chapter for details and pin descriptions of JF1.

**Figure 5-2. Front Control Panel Header Pins (JF1)**

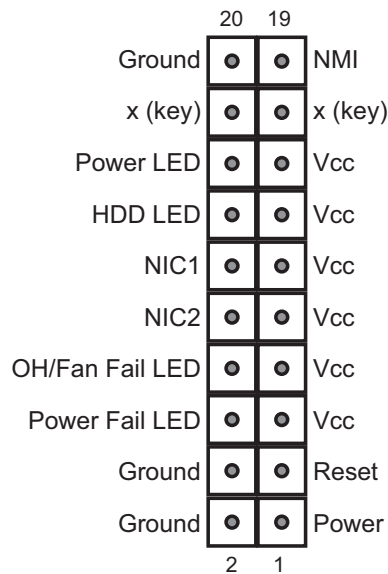

## 5-5 I/O Ports

The I/O ports are color coded in conformance with the PC 99 specification. See Figure 5-3 below for the colors and locations of the various I/O ports.

**Figure 5-3. Rear Panel I/O Ports**

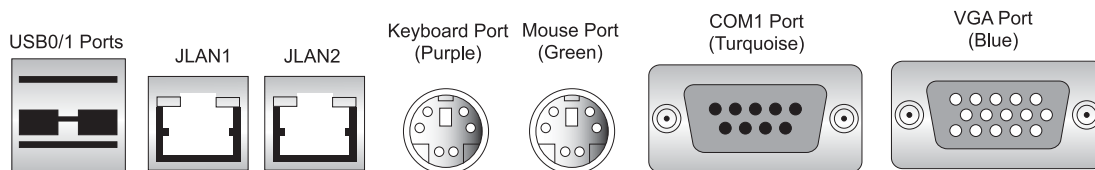

## 5-6 Installing Memory

---

### **CAUTION**

Exercise extreme care when installing or removing memory modules to prevent any possible damage.

---

1. Insert each memory module vertically into its slot, paying attention to the notch along the bottom of the module to prevent inserting the module incorrectly (see Figure 2-2). See support information below.

2. Gently press down on the memory module until it snaps into place.

**Notes:** each processor has its own built-in memory controller, so CPU2 DIMMs cannot be addressed if only a single CPU is installed. 128 MB, 256 MB, 512 MB, 1 GB, 2 GB\* and 4 GB\* memory modules are supported.

\*With Opteron 246 C-stepping CPUs and above.

It is highly recommended that you remove the power cord from the system before installing or changing any memory modules.

## Support

The H8SSP-8/H8SSP-i supports single or dual-channel, registered ECC DDR400/333/266 SDRAM.

Both interleaved and non-interleaved memory are supported, so you may populate any number of DIMM slots (see note on previous page).

Populating two adjacent slots at a time with memory modules of the same size and type will result in interleaved (128-bit) memory, which is faster than non-interleaved (64-bit) memory.

**Maximum memory:** 16 GB for DDR333/266 and 8 GB for DDR400.

**Figure 5-4. Side and Top Views of DDR Installation**

### **To Install:**

Insert module vertically and press down until it snaps into place. The release tabs should close - if they do not you should close them yourself.

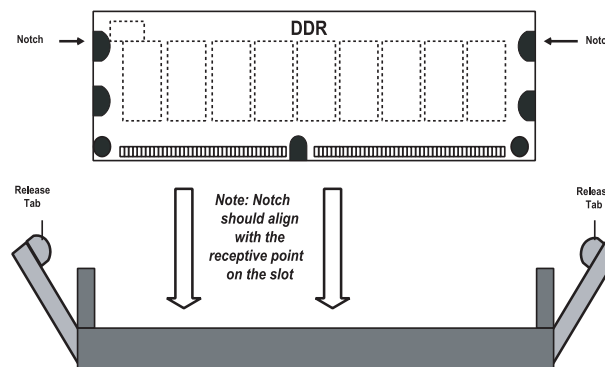

Note the notch in the slot and on the bottom of the DIMM. These prevent the DIMM from being installed incorrectly.

### **To Remove:**

Use your thumbs to gently push each release tab outward to release the DIMM from the slot.

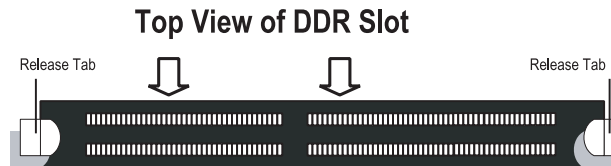

## 5-7 Adding PCI Cards

### 1. PCI slots

The H8SSP-8/H8SSP-i has one PCI-X 133 MHz, one PCI-X 100 MHz and two PCI-Express x8 expansion slots. Four riser cards are included with the server to make two expansion slots available in a 1U chassis format: the CSE-RR1U-XR (or CSE-RR1U-ER) riser card fits into the PCI-X slot #2 (or PCI-E slot #2) to support a full-height, full-length add-on card and the CSE-RR1U-X (or CSE-RR1U-EL) riser card fits into the PCI-X slot #1 (or PCI-E slot #1) to support a low profile add-on card.

### 2. PCI card installation

Before installing an add-on card, make sure it conforms to the correct riser card (see step 1, above).

Begin by swinging the release tab on the PCI shield that corresponds to the riser card/expansion slot you wish to populate. Insert the correct riser card (depending on whether it is a standard or low-profile card and whether a PCI-X or PCI-E card) then the PCI card into the riser card, pushing down with your thumbs evenly on both sides of the card. Finish by pushing the release tab back to its original (locked) position. Follow this procedure when adding a card to either slot.

## 5-8 Serverboard Details

**Figure 5-5. H8SSP-8/H8SSP-i Serverboard Layout**  
(not drawn to scale)

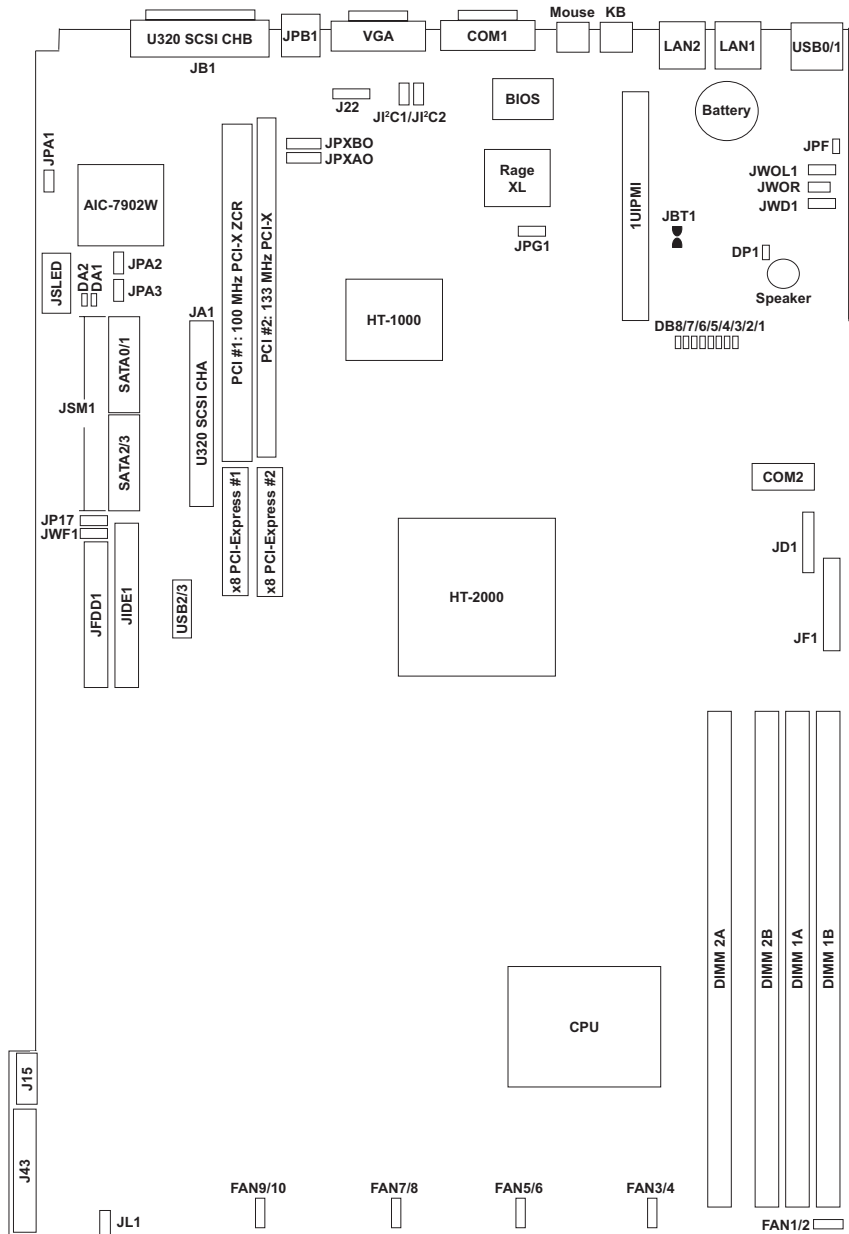

**Notes:**

Jumpers not indicated are for test purposes only.

The H8SSP-i shares the same layout but does not have SCSI connectors and jumpers.

## H8SSP-8/H8SSP-i Quick Reference

<b>Jumpers</b>	<b>Description</b>	<b>Default Setting</b>
JBT1	CMOS Clear	See Section 5-10
JD1	Onboard Spkr En/Disable	Pins 6-7 (Enabled)
JI <sup>2</sup> C1/2	I <sup>2</sup> C to PCI Enable/Disable	Closed (Enabled)
JP17	DOC Bus Select	Closed (Master)
JPA1*	SCSI Enable/Disable	Pins 1-2 (Enabled)
JPA2/JPA3*	SCSI Channel A/B Term.	Open (Enabled)
JPF	Power Force On	Open (Normal)
JPG1	VGA Enable/Disable	Pins 1-2 (Enabled)
JPXAO/JPXBO	PCI-X#1/#2 Freq. Select	Open (Auto)
JWD1	Watch Dog	Pins 1-2 (Reset)

<b>Connectors</b>	<b>Description</b>
1U IPMI	IPMI 2.0 Slot
COM1/COM2	COM1/2 Serial Port/Header
FAN1/2 - 9/10	Fan Headers
J15	Secondary Power Connector
J22	System Management Bus (IPMB) Header
J43	Primary ATX Power Connector (proprietary)
JA1*	Ultra320 SCSI Channel A Connector
JB1*	Ultra320 SCSI Channel B Connector
JD1	Power LED/Speaker Header
JF1	Front Panel Headers
JFDD1	Floppy Disk Drive Connector
JIDE#1	IDE#1 Connector
JL1	Chassis Intrusion Header
JLAN1/2	Gigabit Ethernet (RJ45) Ports
JSLED*	SCSI LED Activity Header
JSM1	4-Port Serial ATA Connector (SATA0/1/2/3)
JWF1	DOC Power Header
JWOL1	Wake-On-LAN Header
JWOR	Wake-On-Ring Header
USB0/1/2/3	Universal Serial Bus Ports (0/1) and Headers (2/3)
VGA	Video (Monitor) Port

<b>Onboard LEDs</b>	<b>Description</b>
DA1/DA2*	SCSI Channel A/B Activity LEDs
DB1-DB8	POST Code LEDs
DP1	+3.3V Standby Power LED
JPB1	UID (Unit Identifier) LED/Button

\*H8SSP-8 only

## 5-9 Connector Definitions

### Primary ATX Power Connector

The primary power supply connector (J43) on the H8SSP-8/H8SSP-i is a proprietary design with unique pinouts and requires the correct proprietary power supply to operate. Refer to the table on the right for the pin definitions of the J43 main power connector. You must also connect the J15 power connector to your power supply (see below).

ATX Power 20-pin Connector Pin Definitions (J43)			
Pin#	Definition	Pin #	Definition
11	Ground	1	Ground
12	+5V	2	Ground
13	+5V	3	Ground
14	+3.3V	4	Ground
15	+3.3V	5	Ground
16	+5VSB	6	Ground
17	+12V	7	Ground
18	+12V	8	+12V <sub>2</sub>
19	+12V <sub>1</sub>	9	+12V <sub>2</sub>
20	NC	10	+12V <sub>1</sub>

#### Required Connection

### Secondary Power Connector

In addition to the Primary ATX power connector (above), the 10-pin power connector at J15 must also be connected to your power supply. See the table on the right for pin definitions. Note that the pin arrangement is different than usual, with pins 1 and 2 on opposite sides.

Secondary Power Connector Pin Definitions (J15)			
Pin#	Definition	Pin #	Definition
1	SMBus I <sup>2</sup> C Clock	2	Ground
3	SMBus I <sup>2</sup> C Data	4	Power Fail
5	Ground	6	Power Good
7	Power On	8	-12V
9	NC	10	No pin

#### Required Connection

### NMI Button

The non-maskable interrupt button header is located on pins 19 and 20 of JF1. Refer to the table on the right for pin definitions.

NMI Button Pin Definitions (JF1)	
Pin#	Definition
19	Control
20	Ground

### Power LED

The Power LED connection is located on pins 15 and 16 of JF1. Refer to the table on the right for pin definitions.

Power LED Pin Definitions (JF1)	
Pin#	Definition
15	Vcc
16	Control

## HDD LED

The HDD (IDE Hard Disk Drive) LED connection is located on pins 13 and 14 of JF1. Attach the IDE hard drive LED cable to display disk activity. Refer to the table on the right for pin definitions.

HDD LED Pin Definitions (JF1)	
Pin#	Definition
13	Vcc
14	HD Active

## NIC1 LED

The NIC1 (Network Interface Controller) LED connection is located on pins 11 and 12 of JF1. Attach the NIC1 LED cable to display network activity. Refer to the table on the right for pin definitions.

NIC1 LED Pin Definitions (JF1)	
Pin#	Definition
11	Vcc
12	NIC1 Active

## NIC2 LED

The NIC2 (Network Interface Controller) LED connection is located on pins 9 and 10 of JF1. Attach the NIC2 LED cable to display network activity. Refer to the table on the right for pin definitions.

NIC2 LED Pin Definitions (JF1)	
Pin#	Definition
9	Vcc
10	NIC2 Active

## Overheat/Fan Fail LED

Connect an LED to the OH connection on pins 7 and 8 of JF1 to provide advanced warning of chassis overheating. Refer to the table on the right for pin definitions.

OH/Fan Fail LED Pin Definitions (JF1)	
Pin#	Definition
7	Vcc
8	Control

## Power Fail LED

The Power Fail LED connection is located on pins 5 and 6 of JF1. See the table on the right for pin definitions.

**Note:** This feature is only available when using redundant power supplies (i.e. the 1010P-8R).

Power Fail LED Pin Definitions (JF1)	
Pin#	Definition
5	Vcc
6	Control

## UID Button and LED

A Unit Identifier button/LED is located on pins 3 and 4 of JF1. Attach it to the hardware reset switch on the computer case. Refer to the table on the right for pin definitions.

UID Button/LED Pin Definitions (JF1)	
Pin#	Definition
3	UID Button
4	UID LED

## Power Button

The Power Button connection is located on pins 1 and 2 of JF1. Momentarily contacting both pins will power on/off the system. This button can also be configured to function as a suspend button (see the Power Button Mode setting in BIOS). To turn off the power when set to suspend mode, depress the button for at least 4 seconds. Refer to the table on the right for pin definitions.

Power Button Pin Definitions (JF1)	
Pin#	Definition
1	PW_ON
2	Ground

## USB0/1 (Universal Serial Bus Ports)

Two Universal Serial Bus ports (USB2.0) are located to the left of the LAN ports. See the table on the right for pin definitions.

Universal Serial Bus Ports Pin Definitions (USB0/1)			
USB0		USB1	
Pin #	Definition	Pin #	Definition
1	+5V	1	+5V
2	PO-	2	PO-
3	PO+	3	PO+
4	Ground	4	Ground

## USB2/3 Headers

Two additional USB2.0 headers (USB2/3) are included on the serverboard. These may be connected to provide front side access. USB cables (not included) are needed for the connections. See the table on the right for pin definitions.

Extra Universal Serial Bus Headers Pin Definitions (USB2/3)			
USB2		USB3/4	
Pin #	Definition	Pin #	Definition
1	+5V	1	+5V
2	PO-	2	PO-
3	PO+	3	PO+
4	Ground	4	Ground
5	Key	5	No connection

## Serial Ports

The COM1 serial port is located between the keyboard and the LAN ports. COM2 is a header located near JD1. See the table on the right for pin definitions.

Serial Port Pin Definitions (COM1/COM2)			
Pin #	Definition	Pin #	Definition
1	DCD	6	DSR
2	RXD	7	RTS
3	TXD	8	CTS
4	DTR	9	RI
5	Ground	10	NC

**Note:** NC indicates no connection.

## Fan Headers

The H8SSP-8/H8SSP-i has five fan headers, each of which support two 4-cm counter-rotating fans. Fan speed is controlled via Thermal Management with a BIOS setting. See the table on the right for pin definitions.

Fan Header Pin Definitions (FAN1/2-9/10)	
Pin#	Definition
1	FAN2 Power
2	FAN2 Tachometer
3	Ground
4	Ground
5	FAN1 Tachometer
6	FAN1 Power

## Chassis Intrusion

A Chassis Intrusion header is located at JL1. Attach the appropriate cable to inform you of a chassis intrusion.

Chassis Intrusion Pin Definitions (JL1)	
Pin#	Definition
1	Intrusion Input
2	Ground

## Power LED/Speaker

On JD1, pins 1, 2, and 3 are for the power LED and pins 4 through 7 are for the speaker. See the tables on the right for pin definitions.

**Note:** The speaker connector pins are for use with an external speaker. If you wish to use the onboard speaker, you should close pins 6 and 7 with a jumper.

PWR LED Connector Pin Definitions (JD1)	
Pin#	Definition
1	+Vcc
2	-Vcc
3	-Vcc

Speaker Connector Pin Definitions (JD1)	
Pin#	Definition
4	Red wire, Speaker data
5	No connection
6	Buzzer signal
7	Speaker data

## ATX PS/2 Keyboard and PS/2 Mouse Ports

The ATX PS/2 keyboard and the PS/2 mouse ports are located between the COM1 and the LAN ports. See the table on the right for pin definitions.

PS/2 Keyboard and Mouse Port Pin Definitions (KB/Mouse)			
Pin #	Definition	Pin #	Definition
1	Data	4	VCC
2	NC	5	Clock
3	Ground	6	NC

## JLAN1/2 (Ethernet Ports)

Two Gigabit Ethernet ports (designated JLAN1 and JLAN2) are located beside the VGA port. These ports accept RJ45 type cables.



## IPMB Header

The Intelligent Platform Management Bus (IPMB) header is located at J22. Connect the appropriate cable here to utilize IPMB on your system. See the table on the right for pin definitions.

IPMB Pin Definitions (J22)	
Pin#	Definition
1	Data
2	Ground
3	Clock
4	N/A

## DOC Power Header

JWF1 is a power header for a DOC (Disk-On-Chip) device. Connect the appropriate cable here to provide power to a DOC device on your system. See the table on the right for pin definitions.

DOC Power Header Pin Definitions (JWF1)	
Pin#	Definition
1	+5V
2	Ground
3	Signal

## Wake-On-Ring

The Wake-On-Ring header is designated JWOR. This function allows your computer to receive and "wake-up" by an incoming call to the modem when in suspend state. See the table on the right for pin definitions. You must have a Wake-On-Ring card and cable to use this feature.

Wake-On-Ring Pin Definitions (JWOR)	
Pin#	Definition
1	Ground (Black)
2	Wake-up

## Wake-On-LAN

The Wake-On-LAN header is designated JWOL1. See the table on the right for pin definitions. You must have a LAN card with a Wake-On-LAN connector and cable to use the Wake-On-LAN feature.

Wake-On-LAN Pin Definitions (JWOL1)	
Pin#	Definition
1	+5V Standby
2	Ground
3	Wake-up

## 5-10 Jumper Settings

### Explanation of Jumpers

To modify the operation of the serverboard, jumpers can be used to choose between optional settings. Jumpers create shorts between two pins to change the function of the connector. Pin 1 is identified with a square solder pad on the printed circuit board. See the diagram at right for an example of jumping pins 1 and 2. Refer to the serverboard layout page for jumper locations.

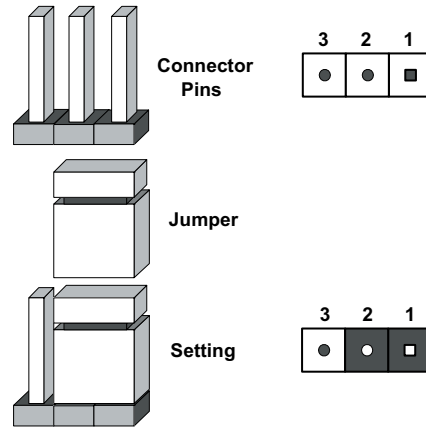

**Note 1:** On two-pin jumpers, "Closed" means the jumper is on and "Open" means the jumper is off the pins.

### CMOS Clear

JBT1 is used to clear CMOS and will also clear any passwords. Instead of pins, this jumper consists of contact pads to prevent accidentally clearing the contents of CMOS.

To clear CMOS,

- 1) First power down the system and unplug the power cord(s).
- 2) With the power disconnected, short the CMOS pads with a metal object such as a small screwdriver for at least four seconds.
- 3) Remove the screwdriver (or shorting device).
- 4) Reconnect the power cord(s) and power on the system.

#### Notes:

Do not use the PW\_ON connector to clear CMOS.

The onboard battery does not need to be removed when clearing CMOS, however you must short JBT1 for at least four seconds.



JBT1 contact pads

## PCI-X#1/#2 Frequency Select

Jumpers JXAO and JXBO are used to set the speed of PCI-X slots 1 and 2, respectively. The recommended (default) setting is open for Auto. See the table on the right for jumper settings.

PCI-X#1/#2 Frequency Select Jumper Settings (JXAO/JXBO)	
Jumper Setting	Definition
Pins 1-2	66 MHz PCI-X
Pins 2-3	66 MHz PCI
Open	Auto

## Onboard Speaker Enable/Disable

The JD1 header allows you to use either an external speaker or the internal (onboard) speaker. To use the internal (onboard) speaker, close pins 6 and 7 with a jumper. To use an external speaker, connect the speaker wires to pins 4 through 7 of JD1. See the table on the right for settings and the table associated with the Power LED/Speaker connection (previous section) for pin definitions.

Onboard Speaker Enable/Disable Pin Definitions (JD1)	
Pins	Definition
6-7	Jump for onboard speaker
4-7	Attach external speaker wires

## Watch Dog

JWD1 controls the Watch Dog function. Watch Dog is a system monitor that can reboot the system when a software application hangs. Pins 1-2 will cause WD to reset the system if an application has frozen. Pins 2-3 will generate a non-maskable interrupt signal for the application that is frozen. See the table on the right for jumper settings. Watch Dog must also be enabled in BIOS.

Watch Dog Jumper Settings (JWD1)	
Jumper Setting	Definition
Pins 1-2	Reset
Pins 2-3	NMI
Open	Disabled

**Note:** When enabled, the user needs to write their own application software in order to disable the Watch Dog Timer.

### SCSI Controller Enable/ Disable (H8SSP-8 only)

Jumper JPA1 is used to enable or disable the Adaptec AIC-7902W SCSI controller. The default setting is on pins 1-2 to enable SCSI. See the table on right for jumper settings.

SCSI Enable/Disable Jumper Settings (JPA1)	
Both Jumpers	Definition
Pins 1-2	Enabled
Pins 2-3	Disabled

### SCSI Termination Enable/ Disable (H8SSP-8 only)

Jumpers JPA2 and JPA3 are used to enable or disable termination for SCSI channels A and B, respectively. The default setting is open to enable termination. See the table on right for pin definitions.

SCSI Term. Enable/Disable Jumper Settings (JPA2/JPA3)	
Jumper Setting	Definition
Open	Enabled
Closed	Disabled

**Note:** In order for the SCSI drives to function properly, please do not change the default setting (enabled) set by the manufacturer.)

### VGA Enable/Disable

JPG1 allows you to enable or disable the VGA port. The default position is on pins 1 and 2 to enable VGA. See the table on the right for jumper settings.

VGA Enable/Disable Jumper Settings (JPG1)	
Jumper Setting	Definition
Pins 1-2	Enabled
Pins 2-3	Disabled

### Power Force On

JPF allows you to enable or disable the Power Force On function. If enabled, system power will always stay on. If disabled (the default setting), the user needs to depress the power button to power up the system.

Power Force On Jumper Settings (JPF)	
Jumper Setting	Definition
Closed	Force On
Open	Disabled

## I<sup>2</sup>C to PCI Enable/Disable

JI<sup>2</sup>C1/2 pair of jumpers allow you to connect the System Management Bus to any one of the PCI slots. The default setting is closed for both jumpers to enable the connection. Both connectors must have the same setting (JI<sup>2</sup>C1 is for data and JI<sup>2</sup>C2 is for the clock). See the table on right for jumper settings.

I <sup>2</sup> C to PCI Enable/Disable Jumper Settings (JI <sup>2</sup> C1/JI <sup>2</sup> C2)	
Jumper Setting	Definition
Closed	Enabled
Open	Disabled

## DOC IDE Bus Select

Jumper JP17 allows the user to choose either master or slave mode for a DOC (Disk-On-Chip) device that has been plugged into the IDE slot. See the table on right for jumper settings.

DOC IDE Bus Select Enable/Disable Jumper Settings (JP17)	
Jumper Setting	Definition
Open	Slave
Closed	Master

## 5-11 Onboard Indicators

### JLAN1/JLAN2 LEDs

The Ethernet ports (located beside the VGA port) have two LEDs. On each Gb LAN port, the right (yellow) LED indicates activity while the left (orange) LED indicates when there is a connection (link). See the table on the right for the functions associated with the left (connection) LED.

JLAN Left LED (Connection Indicator)	
LED Color	Definition
Off	No Connection
Orange	Connection

### +3.3V Power LED

When illuminated, the DP1 LED indicates that power from the power supply is being supplied to the serverboard (DP1 indicates the presence of +3.3V). See the table on the right for DP1 LED states.

+3.3V Power LED (DP1)	
State	System Status
On	Power present on serverboard
Off	No power present on serverboard

### SCSI Activity LEDs (H8SSP-8 only)

There are two SCSI activity LEDs on the serverboard. When illuminated, DA1 indicates activity on SCSI channel A and DA2 indicates activity on SCSI channel B.

SCSI Channel Activity LEDs (DA1/DA2)	
State	System Status
On	SCSI Channel Active
Off	SCSI Channel Inactive

### POST Code LEDs

Eight surface-mounted LEDs are located near one end of the 1UIPMI slot. These LEDs are used to provide POST code information. See the diagrams below for reading the LEDs and refer to Appendix B for a complete list of POST codes.

↑  
Toward edge of board

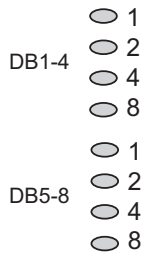

*Example:*

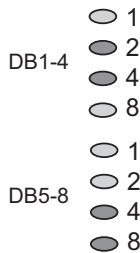

● = Illuminated LED (1)  
○ = Unilluminated LED (0)

#### Reading the POST Code LEDs

When on, each of the eight separate LEDs represent the value of the number shown beside it in the diagram on the left. Add up the numerical values of each illuminated LED in the DB5-DB8 column to get the high (left) digit and those in the DB1-DB4 column to get the low (right) digit of the corresponding POST code.

Example:

The example on the left indicates a hexadecimal POST code of C6. This is determined in the following manner:

DB1-DB4 (low digit): 4 + 2 = 6

DB5-DB8 (high digit): 8 + 4 = 12

(decimal 12 = hexadecimal C)

Decimal	Hexidecimal Equivalent
0-9	0-9
10	A
11	B
12	C
13	D
14	E
15	F

## 5-12 Floppy, IDE, SCSI and SATA Drive Connections

Use the following information to connect the floppy and hard disk drive cables.

- The floppy disk drive cable has seven twisted wires.
- A red mark on a wire typically designates the location of pin 1.
- A single floppy disk drive ribbon cable has 34 wires and two connectors to provide for two floppy disk drives. The connector with twisted wires always connects to drive A, and the connector that does not have twisted wires always connects to drive B.
- The 80-wire ATA100 IDE hard disk drive cable that came with your system has two connectors to support two drives. The blue connector connects to the on-board IDE connector interface and the other connector(s) to your hard drive(s). Consult the documentation that came with your disk drive for details on actual jumper locations and settings for the hard disk drive.

### Floppy Connector

The floppy connector is located beside the IDE#1 connector. See the table on the right for pin definitions.

Floppy Drive Connector Pin Definitions (JFDD1)			
Pin#	Definition	Pin #	Definition
1	GND	2	FDHDIN
3	GND	4	Reserved
5	Key	6	FDEDIN
7	GND	8	Index-
9	GND	10	Motor Enable
11	GND	12	Drive Select B-
13	GND	14	Drive Select A-
15	GND	16	Motor Enable
17	GND	18	DIR-
19	GND	20	STEP-
21	GND	22	Write Data-
23	GND	24	Write Gate-
25	GND	26	Track 00-
27	GND	28	Write Protect-
29	GND	30	Read Data-
31	GND	32	Side 1 Select-
33	GND	34	Diskette

## IDE Connector

There are no jumpers to configure the onboard IDE connector. See the table on the right for pin definitions.

IDE Drive Connector Pin Definitions (JIDE#1)			
Pin#	Definition	Pin #	Definition
1	Reset IDE	2	Ground
3	Host Data 7	4	Host Data 8
5	Host Data 6	6	Host Data 9
7	Host Data 5	8	Host Data 10
9	Host Data 4	10	Host Data 11
11	Host Data 3	12	Host Data 12
13	Host Data 2	14	Host Data 13
15	Host Data 1	16	Host Data 14
17	Host Data 0	18	Host Data 15
19	Ground	20	Key
21	DRQ3	22	Ground
23	I/O Write	24	Ground
25	I/O Read	26	Ground
27	IOCHRDY	28	BALE
29	DACK3	30	Ground
31	IRQ14	32	IOCS16
33	Addr1	34	Ground
35	Addr0	36	Addr2
37	Chip Select 0	38	Chip Select 1
39	Activity	40	Ground

### SCSI Connectors (H8SSP-8 only)

Refer to the table at right for pin definitions for the Ultra320 SCSI connectors located at JA1 and JB1.

Ultra320 SCSI Drive Connectors Pin Definitions (JA1/JB1)			
Pin#	Definition	Pin #	Definition
1	+DB (12)	35	-DB (12)
2	+DB (13)	36	-DB (13)
3	+DB (14)	37	-DB (14)
4	+DB (15)	38	-DB (15)
5	+DB (P1)	39	-DB (P1)
6	+DB (0)	40	-DB (0)
7	+DB (1)	41	-DB (1)
8	+DB (2)	42	-DB (2)
9	+DB (3)	43	-DB (3)
10	+DB (4)	44	-DB (4)
11	+DB (5)	45	-DB (5)
12	+DB (6)	46	-DB (6)
13	+DB (7)	47	-DB (7)
14	+DB (P)	48	-DB (P)
15	Ground	49	Ground
16	DIFFSENS	50	Ground
17	TERMPWR	51	TERMPWR
18	TERMPWR	52	TERMPWR
19	Reserved	53	Reserved
20	Ground	54	Ground
21	+ATN	55	-ATN
22	Ground	56	Ground
23	+BSY	57	-BSY
24	+ACK	58	-ACK
25	+RST	59	-RST
26	+MSG	60	-MSG
27	+SEL	61	-SEL
28	+C/D	62	-C/D
29	+REQ	63	-REQ
30	+I/O	64	-I/O
31	+DB (8)	65	-DB (8)
32	+DB (9)	66	-DB (9)
33	+DB (10)	67	-DB (10)
34	+DB (11)	68	-DB (11)

## SATA Connector

There are no jumpers to configure the SATA connector. JSM1 is a 4-port connector that includes designations SATA0 through SATA3. See the table on the right for pin definitions. This is a four-port connector.

SATA 4-Port Connector Pin Definitions (JSM1)			
Pin#	Definition	Pin #	Definition
1	Ground	2	RXD+
3	RXD-	4	Ground
5	TXD-	6	TXD+
7	Ground	8	RX1+
9	RX1-	10	Ground
11	TX1-	12	TX1+
13	Ground	14	SB0
15	SB1	16	SB2
17	SB3	18	SB4
19	SB5	20	Ground
21	RX2+	22	RX2-
23	Ground	24	TX2-
25	TX2+	26	Ground
27	RX3+	28	RX3-
29	Ground	30	TX3-
31	TX3+	32	Ground
33	NC	34	NC
35	Ground	36	Ground

**Note:** NC indicates no connection.

## Chapter 6

### Advanced Chassis Setup

This chapter covers the steps required to install components and perform maintenance on the SC816S-(R)400/SC816T-(R)400 chassis. For component installation, follow the steps in the order given to eliminate the most common problems encountered. If some steps are unnecessary, skip ahead to the next step.

#### Tools Required

The only tool you will need to install components and perform maintenance is a Philips screwdriver.

#### 6-1 Static-Sensitive Devices

Electricstatic discharge (ESD) can damage electronic components. To prevent damage to any printed circuit boards (PCBs), it is important to handle them very carefully. The following measures are generally sufficient to protect your equipment from ESD damage.

##### Precautions

- Use a grounded wrist strap designed to prevent static discharge.
- Touch a grounded metal object before removing any board from its antistatic bag.
- Handle a board by its edges only; do not touch its components, peripheral chips, memory modules or gold contacts.
- When handling chips or modules, avoid touching their pins.
- Put the serverboard, add-on cards and peripherals back into their antistatic bags when not in use.
- For grounding purposes, make sure your computer chassis provides excellent conductivity between the power supply, the case, the mounting fasteners and the serverboard.

Figure 6-1. Chassis: Front and Rear Views

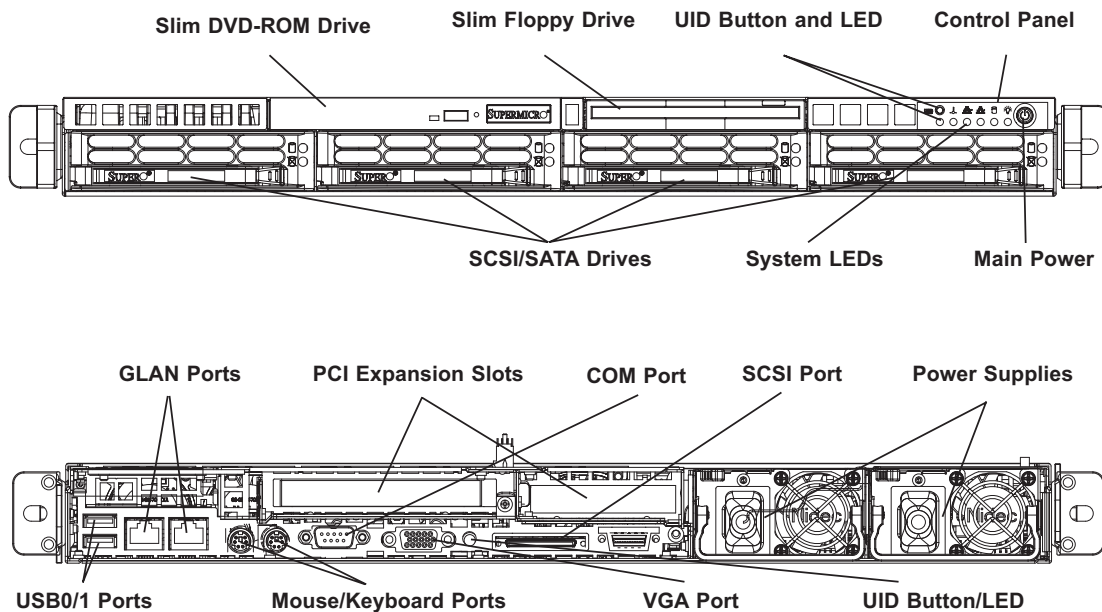

**Notes:** The 1010P-8/1010P-T shares the same rear view as shown above but has a cover plate over the second (redundant) power supply module. The 1010P-T/1010P-TR does not have an external SCSI port.

## 6-2 Control Panel

The control panel (located on the front of the chassis) must be connected to the JF1 connector on the serverboard to provide you with system status indications. A ribbon cable has bundled these wires together to simplify the connection. Connect the cable from JF1 on the serverboard to the appropriate header on the Control Panel PCB (printed circuit board). Make sure the red wire plugs into pin 1 on both connectors. Pull all excess cabling out of the airflow path.

The control panel LEDs inform you of system status. See "Chapter 3: System Interface" for details on the LEDs and the control panel buttons. Details on JF1 can be found in "Chapter 5: Advanced Serverboard Setup."

## 6-3 System Fans

Three 4-cm fans provide the cooling for the 1010P-8(R)/1010P-T(R). Each fan unit is actually made up of two fans joined back-to-back, which rotate in opposite directions. This counter-rotating action generates exceptional airflow and works to dampen vibration levels. These fans can adjust their speed according to the heat level sensed in the system, which results in more efficient and quieter fan operation. Fan speed is controlled by a setting in BIOS (see Chapter 7). Each fan in a set has its own separate tachometer.

It is very important that the chassis top cover is properly installed for the airflow to circulate properly through the chassis and cool the components.

### System Fan Failure

If a fan fails, the remaining fans will ramp up to full speed and the overheat/fan fail LED on the control panel will blink on and off. Replace any failed fan at your earliest convenience with the same type and model (the system can continue to run with a failed fan). Remove the top chassis cover while the system is still running to determine which of the two fan units has failed. Then power down the system before replacing a fan. Removing the power cord(s) is also recommended as a safety precaution.

### Replacing System Cooling Fans

#### 1. Removing a fan

With the system powered down, first remove the chassis cover (refer to page 6-7) and unplug **all** the fan cables from the serverboard. Grasp the rectangular housing that holds all the fan units and lift it out of the chassis (see Figure 6-2). Push the failed fan out through the bottom of the fan housing.

#### 2. Installing a new fan

Replace the failed fan with an identical 4-cm, 12 volt fan (available from the manufacturer: p/n FAN-0085). Push the new fan into the vacant space in the housing while making sure the arrows on the top of the fan (indicating air direction) point in the same direction as the arrows on the other fans. Reposition the fan housing back over the two mounting posts in the chassis, then reconnect the fan wires to the same chassis fan headers you removed them from. Power up the system and check that the fan is working properly and that the LED on the control panel has turned off. Finish by replacing the chassis cover.

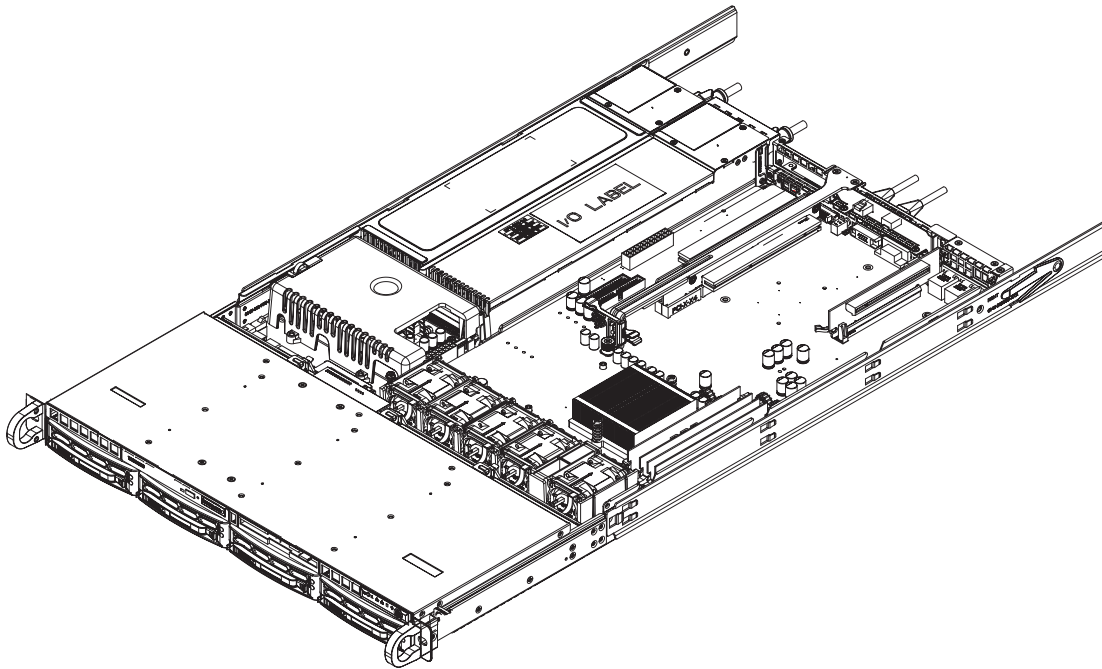

Figure 6-2. Removing the Fan Housing

## 6-4 Drive Bay Installation/Removal

### Accessing the Drive Bays

SCSI/SATA Drives: Because of their hotswap capability, you do not need to access the inside of the chassis or power down the system to install or replace SCSI/SATA drives. Proceed to the next step for instructions.

**Note:** You must use standard 3.5" SCSI/SATA drives in the 1010P-8(R)/1010P-T(R).

DVD/CD-ROM/Floppy Disk Drives: For installing/removing a DVD/CD-ROM or floppy disk drive, you will need to gain access to the inside of the system by removing the top cover of the chassis. Proceed to the "DVD/CD-ROM and Floppy Drive Installation" section later in this chapter for instructions.

**Note:** Only "slim" DVD/CD-ROM and floppy drives will fit into the 1010P-8(R)/1010P-T(R).

## SCSI/SATA Drive Installation

### 1. Mounting a SCSI/SATA drive in a drive carrier

The SCSI/SATA drives are mounted in drive carriers to simplify their installation and removal from the chassis. These carriers also help promote proper airflow. For this reason, even empty carriers without drives installed must remain in the chassis. To add a new drive, install it into the carrier with the printed circuit board side facing down so that the mounting holes align with those in the carrier. Secure the drive to the carrier with six screws, as shown in Figure 6-3.

Figure 6-3. Mounting a SCSI/SATA Drive in a Carrier

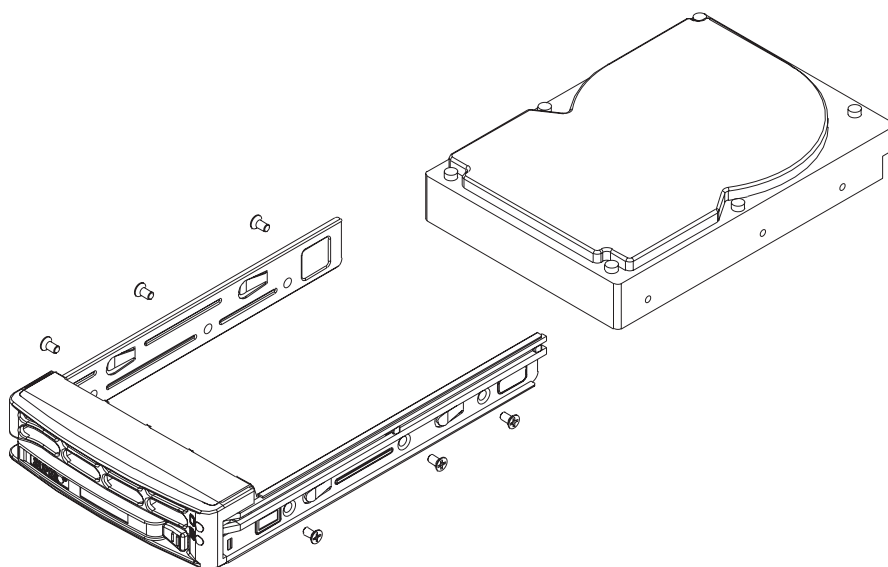

Use caution when working around the SCSI/SATA backplane. Do not touch the backplane with any metal objects and make sure no ribbon cables touch the backplane or obstruct the holes, which aid in proper airflow.



**Important:** Regardless of how many SCSI/SATA hard drives are installed, all drive carriers must remain in the drive bays for proper airflow.

## 2. Installing/removing hot-swap SCSI/SATA drives

The SCSI/SATA drive carriers are all easily accessible at the front of the chassis. These hard drives are hot-pluggable, meaning they can be removed and installed without powering down the system. To remove a carrier, push the release button located beside the drive LEDs. Then swing the colored handle fully out and use it to pull the unit straight out (see Figure 6-4).

**Note:** Your operating system must have RAID support to enable the hot-plug capability of the SCSI drives.

Figure 6-4. Removing a SCSI/SATA Drive Carrier

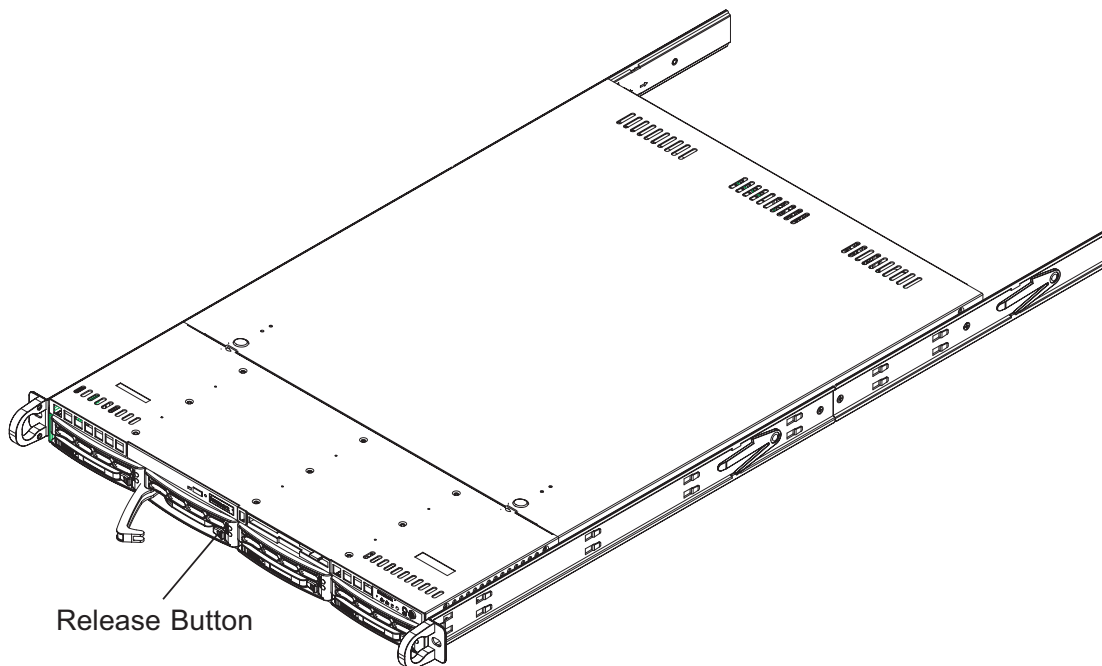

**Important:** All of the drive carriers must remain in the drive bays to maintain proper cooling airflow.

### SCSI/SATA Backplane

The SCSI/SATA drives plug into a backplane that provides power, drive ID and bus termination. A RAID controller can be used with the backplane to provide data security. The operating system you use must have RAID support to enable the hot-swap capability of the drives. The backplane is already preconfigured, so there are no jumpers or switches present on it.

## DVD/CD-ROM and Floppy Drive Installation

The top cover of the chassis must be opened to gain full access to the DVD/CD-ROM and floppy drive bays. The 1010P-8(R)/1010P-T(R) accommodates only slim DVD/CD-ROM and floppy drives. Side mounting brackets are needed to mount the DVD/CD-ROM drive in the server.

You must power down the system before installing or removing a floppy or DVD/CD-ROM drive. First, release the retention screws that secure the server unit to the rack. Grasp the two handles on either side and pull the unit straight out until it locks (you will hear a "click"). Next, depress the two buttons on the top of the chassis to release the top cover and at the same time, push the cover away from you until it stops. You can then lift the top cover from the chassis to gain full access to the inside of the server.

With the chassis cover removed, unplug the power and data cables from the drive you want to remove. Then locate the locking tab at the rear of the drive. It will be on the left side of the drive when viewed from the front of the chassis. Pull the tab away from the drive and push the drive unit out the front of the chassis. Add a new drive by following this procedure in reverse order. You may hear a faint \*click\* of the locking tab when the drive is fully inserted. Remember to reconnect the data and power cables to the drive before replacing the chassis cover and restoring power to the system. Please be aware of the following:

- The floppy disk drive cable has seven twisted wires.
- A color mark on a cable typically designates the location of pin 1.

## 6-5 Power Supply

### 1010P-8R/1010P-TR

The 1010P-8R/1010P-TR has a redundant 400 watt redundant power supply configuration consisting of two hot-swappable power modules. The power supply modules have an auto-switching capability, which enables them to automatically sense and operate with a 100V - 240V input voltage.

#### Power Supply Failure

If either of the two power supply modules fail, the other module will take the full load and allow the system to continue operation without interruption. The Power On LED on the control panel will turn amber and remain so until the failed module has been replaced. Replacement modules can be ordered directly from the manufacturer. The power supply modules have a hot-swap capability, meaning you can replace the failed module without powering down the system.

#### Removing/Replacing the Power Supply

You do not need to shut down the system to replace a power supply module. The redundant feature will keep the system up and running while you replace the failed hot-swap module. Replace with the same model - SP400-1R (p/n PWS-0064).

##### 1. Removing the power supply

First unplug the power cord from the failed power supply module. To remove the failed power module, first locate the colored release tab (1). Push the tab to the right (2) and then pull the module straight out with the handle provided (3) (see Figure 6-5, single power supply server shown). The power supply wiring was designed to detach automatically when the module is pulled from the chassis.

##### 2. Installing a new power supply

Replace the failed hot-swap module with another SP400-1R power supply module. Simply push the new power supply module into the power bay until you hear a click. Finish by plugging the AC power cord back into the module.

## 1010P-8/1010P-T

The 1010P-8/1010P-T has a single 400 watt cold-swap power supply, which is auto-switching capable. This enables it to automatically sense and operate with a 100v - 240v input voltage. An amber light will be illuminated on the power supply when the power is off. An illuminated green light indicates that the power supply is operating.

### Power Supply Failure

If the power supply module fails, the system will shut down and you will need to replace the module. Replacements can be ordered directly from the manufacturer. As there is only one power supply module in the 1010P-8/1010P-T, power must be completely removed from the server before removing and replacing the power supply for whatever reason.

### Removing/Replacing the Power Supply

#### 1. Removing the power supply

First turn the power switch on the control panel off, then unplug the power cord from the system. To remove the failed power module, first locate the colored release tab (1). Push the tab to the right (2) and then pull the module straight out with the handle provided (3) (see Figure 6-5). The power supply wiring was designed to detach automatically when the module is pulled from the chassis.

#### 2. Installing a new power supply

Replace the failed power supply with another SP400-1R power supply module (p/n PWS-0064). Carefully insert the new power supply into the open bay and push it completely into the chassis until you hear a clicking sound, meaning it has been fully inserted. Finish by reconnecting the AC power cord and depressing the power button on the chassis front control panel to restart the system.

Figure 6-5. Removing/Replacing the Power Supply

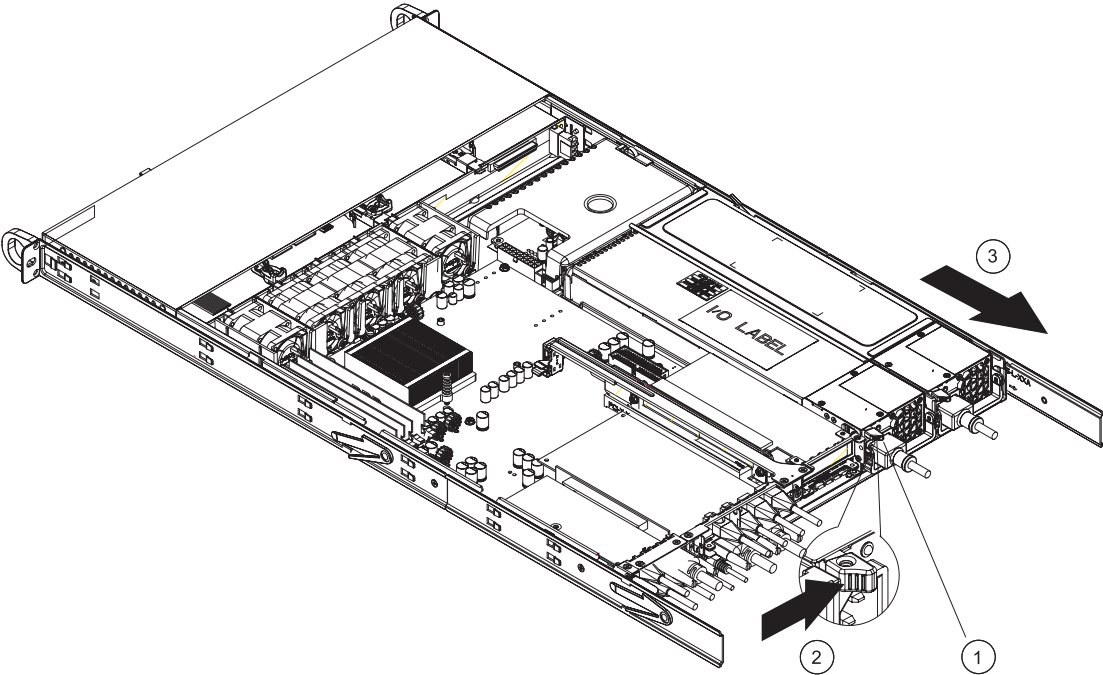

## Chapter 7

# BIOS

### 7-1 Introduction

This chapter describes the AMIBIOS™ Setup utility for the H8SSP-8/H8SSP-i. The AMI ROM BIOS is stored in a flash chip and can be easily upgraded using a floppy disk-based program.

**Note:** Due to periodic changes to the BIOS, some settings may have been added or deleted and might not yet be recorded in this manual. Please refer to the Manual Download area of our web site for any changes to BIOS that may not be reflected in this manual.

#### Starting the Setup Utility

To enter the BIOS Setup Utility, hit the <Delete> key while the system is booting-up. (In most cases, the <Delete> key is used to invoke the BIOS setup screen. There are a few cases when other keys are used, such as <F1>, <F2>, etc.) Each main BIOS menu option is described in this manual.

The Main BIOS screen has two main frames. The left frame displays all the options that can be configured. “Grayed-out” options cannot be configured. The right frame displays the key legend. Above the key legend is an area reserved for a text message. When an option is selected in the left frame, it is highlighted in white. Often a text message will accompany it. (Note that BIOS has default text messages built in. We retain the option to include, omit, or change any of these text messages.) Settings printed in **Bold** are the default values.

A " ►" indicates a submenu. Highlighting such an item and pressing the <Enter> key will open the list of settings within that submenu.

The BIOS setup utility uses a key-based navigation system called hot keys. Most of these hot keys (<F1>, <F10>, <Enter>, <ESC>, <Arrow> keys, etc.) can be used at any time during the setup navigation process.

## 7-2 Main Menu

When you first enter AMI BIOS Setup Utility, you will see the Main setup screen. You can always return to the Main setup screen by selecting the **Main** tab on the top of the screen.

The Main Setup screen provides you with a system overview, which includes the version, built date and ID of the AMIBIOS, the type, speed and number of the processors in the system and the amount of memory installed in the system.

### System Time/System Date

You can edit this field to change the system time and date. Highlight *System Time* or *System Date* using the <Arrow> keys. Enter new values through the keyboard. Press the <Tab> key or the <Arrow> keys to move between fields. The date must be entered in DAY/MM/DD/YYYY format. The time is entered in HH:MM:SS format. Please note that time is in a 24-hour format. For example, 5:30 A.M. appears as 05:30:00 and 5:30 P.M. as 17:30:00.

## 7-3 Advanced Settings Menu

### ► CPU Configuration Sub-Menu

#### GART Error Reporting

This setting is used for testing only.

#### MTRR Mapping

This determines the method used for programming CPU MTRRs when 4 GB or more memory is present. The options are **Continuous**, which makes the PCI hole non-cacheable, and **Discrete**, which places the PCI hole below the 4 GB boundary.

## ► IDE Configuration

### Onboard PCI IDE Controller

The following options are available to set the IDE controller status: Disabled will disable the controller. **Primary** will enable the primary IDE controller. There is no Secondary option since only one IDE slot is provided on the board.

### Primary IDE Master/Slave

Highlight one of the two items above and press <Enter> to access the submenu for that item.

#### Type

Select the type of device connected to the system. The options are Not Installed, **Auto**, CDROM and ARMD.

#### LBA/Large Mode

LBA (Logical Block Addressing) is a method of addressing data on a disk drive. In the LBA mode, the maximum drive capacity is 137 GB. For drive capacities of over 137 GB, your system must be equipped with 48-bit LBA mode addressing. If not, contact your manufacturer or install an ATA/133 IDE controller card that supports 48-bit LBA mode. The options are Disabled and **Auto**.

#### Block (Multi-Sector Transfer)

Block mode boosts IDE drive performance by increasing the amount of data transferred. Only 512 bytes of data can be transferred per interrupt if block mode is not used. Block mode allows transfers of up to 64 KB per interrupt. Select "Disabled" to allow the data to be transferred from and to the device one sector at a time. Select "Auto" to allow the data transfer from and to the device occur multiple sectors at a time if the device supports it. The options are **Auto** and Disabled.

#### PIO Mode

PIO (Programmable I/O) mode programs timing cycles between the IDE drive and the programmable IDE controller. As the PIO mode increases, the cycle time decreases. The options are **Auto**, 0, 1, 2, 3, and 4. Select Auto to allow AMI BIOS to auto detect the PIO mode. Use this value if the IDE disk drive support cannot be determined. Select 0 to allow AMI BIOS to use PIO mode

data transfer rate of 3.3 MBs. Select 1 to allow AMI BIOS to use PIO mode 1 for a data transfer rate of 5.2 MBs. Select 2 to allow AMI BIOS to use PIO mode 2 for a data transfer rate of 8.3 MBs. Select 3 to allow AMI BIOS to use PIO mode 3 for a data transfer rate of 11.1 MBs. Select 4 to allow AMI BIOS to use PIO mode 4 for a data transfer rate of 16.6 MBs. This setting generally works with all hard disk drives manufactured after 1999. For other disk drives, such as IDE CD-ROM drives, check the specifications of the drive.

### **DMA Mode**

Select the DMA mode of the drive. Options are SWDMA0, SWDMA1, SWDMA2, MWDMA0, MWDMA1, MWDMA2, UDMA0, UDMA1 and UDMA2.

### **S.M.A.R.T.**

Self-Monitoring Analysis and Reporting Technology (SMART) can help predict impending drive failures. Select "Auto" to allow BIOS to auto detect hard disk drive support. Select "Disabled" to prevent AMI BIOS from using the S.M.A.R.T. Select "Enabled" to allow AMI BIOS to use the S.M.A.R.T. to support hard drive disk. The options are Disabled, Enabled, and **Auto**.

### **32-Bit Data Transfer**

Select "Enabled" to activate the function of 32-Bit data transfer. Select "Disabled" to deactivate the function. The options are Enabled and **Disabled**.

### **Hard Disk Write Protect**

Select Enabled to enable the function of Hard Disk Write Protect to prevent data from being written to HDD. The options are Enabled or **Disabled**.

### **IDE Detect Time Out (Sec)**

This feature allows the user to set the time-out value for detecting ATA, ATA PI devices installed in the system. The options are 0 (sec), 5, 10, 15, 20, 25, 30 and **35**.

### **ATA(PI) 80Pin Cable Detection**

This setting allows AMI BIOS to auto-detect the 80-Pin ATA(PI) cable. The options are **Host & Device**, Host and Device.

## ► Floppy Configuration

### Floppy A

Move the cursor to these fields via up and down <arrow> keys to select the floppy type. The options are Disabled, 360 KB 5 1/4", 1.2 MB 5 1/4", 720 KB 3 1/2", **1.44 MB 3 1/2"**, and 2.88 MB 3 1/2".

### Floppy B

Move the cursor to these fields via up and down <arrow> keys to select the floppy type. The options are **Disabled**, 360 KB 5 1/4", 1.2 MB 5 1/4", 720 KB 3 1/2", 1.44 MB 3 1/2", and 2.88 MB 3 1/2".

## ► PCI/PnP Menu

### Clear NVRAM

Select Yes to clear NVRAM during boot-up. The options are Yes and **No**.

### Plug & Play OS

Select Yes to allow the OS to configure Plug & Play devices. (This is not required for system boot if your system has an OS that supports Plug & Play.) Select **No** to allow AMIBIOS to configure all devices in the system.

### PCI Latency Timer

This option sets the latency of all PCI devices on the PCI bus. Select a value to set the PCI latency in PCI clock cycles. Options are 32, **64**, 96, 128, 160, 192, 224 and 248.

### Allocate IRQ to PCI VGA

Set this value to allow or restrict the system from giving the VGA adapter card an interrupt address. The options are **Yes** and No.

### Palette Snooping

Select "Enabled" to inform the PCI devices that an ISA graphics device is installed in the system in order for the graphics card to function properly. The options are Enabled and **Disabled**.

### **PCI IDE BusMaster**

Set this value to allow or prevent the use of PCI IDE busmastering. Select "Enabled" to allow AMI BIOS to use PCI busmaster for reading and writing to IDE drives. The options are **Disabled** and Enabled.

### **Offboard PCI/ISA IDE Card**

This option allows the user to assign a PCI slot number to an Off-board PCI/ISA IDE card in order for it to function properly. The options are **Auto**, PCI Slot1, PCI Slot2, PCI Slot3, PCI Slot4, PCI Slot5, and PCI Slot6.

### **IRQ3/IRQ4/IRQ5/IRQ7/IRQ9/IRQ10/IRQ11/IRQ14/IRQ15**

This feature specifies the availability of an IRQ to be used by a PCI/PnP device. Select Reserved for the IRQ to be used by a Legacy ISA device. The options are **Available** and Reserved.

### **DMA Channel0/Channel1/Channel3/Channel5/Channel6/Channel7**

Select Available to indicate that a specific DMA channel is available to be used by a PCI/PnP device. Select Reserved if the DMA channel specified is reserved for a Legacy ISA device. The options are **Available** and Reserved.

### **Reserved Memory Size**

This feature specifies the size of memory block to be reserved for Legacy ISA devices. The options are **Disabled**, 16K, 32K and 64K.

## **► Super IO Configuration**

### **Onboard Floppy Controller**

Use this setting to **Enable** or Disable the onboard floppy controller.

### **Serial Port1 Address**

This option specifies the base I/O port address and Interrupt Request address of serial port 1. Select "Disabled" to prevent the serial port from accessing any system resources. When this option is set to *Disabled*, the serial port physically becomes unavailable. Select "3F8/IRQ4" to allow the serial port to use 3F8 as its I/O port address and IRQ 4 for the interrupt address. The options are Disabled, **3F8/IRQ4**, 3E8/IRQ4 and 2E8/IRQ3.

### **Serial Port2 Address**

This option specifies the base I/O port address and Interrupt Request address of serial port 2. Select "Disabled" to prevent the serial port from accessing any system resources. When this option is set to "Disabled", the serial port physically becomes unavailable. Select "2F8/IRQ3" to allow the serial port to use 2F8 as its I/O port address and IRQ 3 for the interrupt address. The options are Disabled, **2F8/IRQ3**, 3E8/IRQ4 and 2E8/IRQ3.

### **Serial Port 2 Mode**

Tells BIOS which mode to select for serial port 2. The options are **Normal**, Sharp-IR, SIR and Consumer.

### **KBC Clock Source**

The options for the KBC clock source are 8 MHz, **12 MHz** and 16 MHz.

### **Restore on AC Power Loss**

This setting allows you to choose how the system will react when power returns after an unexpected loss of power. The options are Power Off and **Last State**.

### **Watch Dog Timer**

This setting is used to enable or disabled the Watch Dog Timer function. It must be used in conjunction with the Watch Dog jumper (see Chapter 2). Options are **Disabled** and Enabled.

▶ **Chipset Menu**

▶ **North Bridge Configuration**

▶ **Memory Configuration**

**Memclock Mode**

This setting determines how the memory clock is set. **Auto** has the memory clock set by the code and **Limit** allows the user to set a standard value.

**MCT Timing Mode**

Sets the timing mode for memory. Options are **Auto** and **Manual**.

**User Configuration Mode**

Options are **Auto** and **Manual**.

**Bank Interleaving**

This setting is used to determine whether bank interleaving is to be employed. The options are **Auto** and **Disabled**.

**Burst Length**

Use this setting to set the memory burst length. 64-bit Dq must use 4 beats. Options are 8 beats, **4 beats** and 2 beats.

**Enable Clock to All DIMMs**

This setting allows the user to enable unused clocks to DIMMs, even if DIMM slots are empty. Options are **Enabled** and **Disabled**.

**Hardware Memory Hole**

When "Enabled", allows software memory remapping around the memory hole (only supported by rev. E0 processors and above). Options are **Enabled** and **Disabled**.

**Node Interleaving**

Use this setting to **Enable** or **Disable** node interleaving.

## ► ECC Configuration

### DRAM ECC Enable

DRAM ECC allows hardware to report and correct memory errors automatically. Options are **Enabled** and Disabled.

### MCA DRAM ECC Logging

When "Enabled", MCA DRAM ECC logging and reporting is enabled. Options are Enabled and **Disabled**.

### ECC Chip Kill

Allows the user to Enable or **Disable** ECC Chip Kill.

### DRAM Scrub Redirect

Allows system to correct DRAM ECC errors immediately, even with background scrubbing on. Options are Enabled and **Disabled**.

### DRAM BG Scrub

Corrects memory errors so later reads are correct. Options are **Disabled** and various times in nanoseconds and microseconds.

### L2 Cache BG Scrub

Allows L2 cache RAM to be corrected when idle. Options are **Disabled** and various times in nanoseconds and microseconds.

### Data Cache BG Scrub

Allows L1 cache RAM to be corrected when idle. Options are **Disabled** and various times in nanoseconds and microseconds.

## Power Down Control

This feature allows DIMMs to enter a power down mode by deasserting the clock enable signal when DIMMs are not in use. The options are **Auto** and Disabled.

## Memory Timing Parameters

Select **CPU Node0** or CPU Node1 to view the parameters for that node in the field below.

▶ **HT2000 System I/O Configuration**

**EXB\_B Split to 2 (x4)**

Enable or **Disable** EXB\_B Split to 2.

**EXB\_C Split to 2 (x4)**

Enable or **Disable** EXB\_C Split to 2.

▶ **HT1000 SouthBridge Configuration**

**HIDE XIOAPIC PCI Functions**

The options are **Yes** and No.

▶ **S-ATA Configuration**

**HT-1000 S-ATA**

Use this setting to **Enable** or Disable the on-chip SATA controller.

**S-ATA Mode**

Use this select either IDE, MMIO or **RAID** as the SATA mode.

▶ **ACPI Configuration**

▶ **Advanced ACPI Configuration**

**ACPI Version Features**

Select which version of ACPI you wish to use. Options are **ACPI v. 1.0**, ACPI v. 2.0 and ACPI v. 3.0.

**ACPI APIC Support**

Select "Enabled" to allow the ACPI APIC Table Pointer to be included in the RSDT pointer list. The options are **Enabled** and Disabled.

**ACPI OEMB Table**

This setting when enabled will include an OEMB table pointer to pointer lists. Options are **Enabled** and Disabled.

### **Headless Mode**

Select "Enabled" to activate the Headless Operation Mode through ACPI. The options are Enabled and **Disabled**.

## ▶ **Event Log Configuration**

### **View Event Log**

Highlight this item and press <Enter> to view the contents of the event log.

### **Mark All Events as Read**

Highlight this item and press <Enter> to mark the DMI events as read.

### **Clear Event Log**

This setting will clear all event logs when set to "OK". The options are OK and **Cancel**.

### **Event Log Statistics**

Highlight this item and press <Enter> to view details on the count of total unread events.

## ▶ **Hyper Transport Configuration**

### **CPU0: CPU1 HT Link Speed**

The HT link will run at the speed specified in this setting if it is slower than or equal to the system clock and if the board is capable. Options are **Auto**, 200 MHz, 400 MHz, 600 MHz, 800 MHz and 1 GHz.

### **CPU0: CPU1 HT Link Width**

The HT link will run at the width specified in this setting. Options are **Auto**, 2 bit, 4 bit, 8 bit and 16 bit.

### **CPU0: HT2000 HT Link Speed**

The HT link will run at the speed specified in this setting if it is slower than or equal to the system clock and if the board is capable. Options are **Auto**, 200 MHz, 400 MHz, 600 MHz, 800 MHz and 1 GHz.

### **CPU0: HT2000 HT Link Width**

The HT link will run at the width specified in this setting. Options are **Auto**, 2 bit, 4 bit, 8 bit and 16 bit.

### **HT2000: HT1000 HT Link Speed**

The HT link will run at the speed specified in this setting if it is slower than or equal to the system clock and if the board is capable. Options are **Auto**, 200 MHz, 400 MHz, 600 MHz and 800 MHz.

### **HT2000: HT1000 HT Link Width**

The HT link will run at the width specified in this setting. Options are **Auto**, 2 bit, 4 bit and 8 bit.

## **▶ MPS Configuration**

### **MPS Revision**

This setting allows the user to select the MPS revision level. The options are 1.1 and 1.4.

## **▶ PCI Express Configuration**

### **Active State Power Management**

This setting is used to Enable or **Disable** the PCI Express L0s and L1 Link power states.

## **▶ AMD PowerNow Configuration**

### **PowerNow**

This setting allows the user to Enable or **Disable** the AMD PowerNow feature.

## **▶ Remote Access Configuration**

### **Remote Access**

Use this setting to Enable or **Disable** remote access. If Enabled is selected, you can select a Remote Access type.

## ► **USB Configuration**

This screen will display the module version and all USB enabled devices.

### **Legacy USB Support**

Select "Enabled" to enable the support for USB Legacy. Disable Legacy support if there are no USB devices installed in the system. The options are **Enabled** and Disabled.

### **USB 2.0 Controller Mode**

Select the controller mode for your USB ports. Options are HiSpeed and **FullSpeed**. (HiSpeed=480 Mbps, FullSpeed=12 Mbps).

### **BIOS EHCI Hand-Off**

**Enable** or Disable a workaround for OS's without EHCI hand-off support.

## ► **System Health Monitor**

### **CPU Overheat Temperature**

Use the "+" and "-" keys to set the CPU temperature threshold to between 65° and 90° C. When this threshold is exceeded, the overheat LED on the chassis will light up and an alarm will sound. The LED and alarm will turn off once the CPU temperature has dropped to 5 degrees below the threshold set. The default setting is **78° C**.

The other items in the submenu are all systems monitor displays for the following information:

CPU1 Temperature, CPU2 Temperature (for dual CPU systems), System Temperature, CPU1 Vcore, CPU2 Vcore (for dual CPU systems), +5 Vin, +12Vin, -12V Vcc, DDRA VTT, DDRB VTT, 1.2V for Hyper-Transport, 2.5V, 5V standby, 2.5V standby and battery voltage.

## ► System Fan Monitor

### Fan Speed Control Modes

This feature allows the user to determine how the system will control the speed of the onboard fans. If the option is set to "3-pin fan", the fan speed is controlled based upon the CPU die temperature. When the CPU die temperature is higher, the fan speed will be higher as well. If the option is set to "4-pin", the fan speed will be controlled by the Thermal Management Settings pre-configured by the user with this setting. Select "3-pin" if your chassis came with 3-pin fan headers. Select "4-pin" if your chassis came with 4-pin fan headers. Select "Workstation" if your system is used as a Workstation. Select "Server" if your system is used as a Server. Select "Disable" to disable the fan speed control function to allow the onboard fans to continuously run at full speed (12V). The options are 1) Disable, Full Speed and 2) **Server Mode**.

### FAN1 Speed through FAN10 Speed

The speeds of the onboard fans (in rpm) are displayed here.

## 7-4 Boot Menu

### ► Boot Settings Configuration

#### Quick Boot

If Enabled, this option will skip certain tests during POST to reduce the time needed for the system to boot up. The options are **Enabled** and Disabled.

#### Quiet Boot

If **Disabled**, normal POST messages will be displayed on boot-up. If Enabled, this display the OEM logo instead of POST messages.

#### Add-On ROM Display Mode

This setting controls the display of add-on ROM (read-only memory) messages. Select "**Force BIOS**" to allow the computer system to force a third party BIOS to display during system boot. Select "Keep Current" to allow the computer system to display the BIOS information during system boot.

#### Boot up Num-Lock

Set this to "On" to allow the Number Lock setting to be modified during boot up. The options are **On** and Off.

#### PS/2 Mouse Support

This setting is to specify PS/2 mouse support. The options are **Auto**, Enabled and Disabled.

#### Wait for 'F1' If Error

Enable to activate the Wait for F1 if Error function. The options are **Enabled** and Disabled.

#### Hit 'DEL' Message Display

Enable to display the message telling the user to hit the DEL key to enter the setup utility. The options are **Enabled** and Disabled.

#### Interrupt 19 Capture

Enable to allow ROMs to trap Interrupt 19. The options are Enabled and **Disabled**.

## ► **Boot Device Priority**

This feature allows the user to prioritize the sequence for the Boot Device with the devices installed in the system. The default settings (with generic names) are:

- 1st Boot Device – Removeable drive (e.g. floppy drive)
- 2nd Boot Device – CD/DVD
- 3rd Boot Device – Hard drive
- 4th Boot Device – LAN

## ► **Hard Disk Drives**

This feature allows the user to prioritize the Boot sequence from available hard drives.

### **1st Drive/2nd Drive/3rd Drive/4th Drive/5th Drive**

Specify the boot sequence for the available hard drives on the system.

## ► **Removable Drives**

This feature allows the user to specify the Boot sequence from available removable drives.

### **1st Drive**

Specifies the boot sequence for the 1st Removable Drive.

## ► **CD/DVD Drives**

This feature allows the user to specify the boot sequence from available CDROM drives.

### **1st Drive**

Specifies the boot sequence for the 1st Hard Drive.

## **Onboard SCSI HostRAID**

Use this setting to Enable or **Disable** the onboard SCSI Host RAID.

## **Onboard NIC PXE Option ROM**

Use this setting to **Enable** or Disable the onboard NIC PXE option ROM.

## 7-5 Security Menu

AMI BIOS provides a Supervisor and a User password. If you use both passwords, the Supervisor password must be set first.

### **Change Supervisor Password**

Select this option and press <Enter> to access the sub menu, and then type in the password.

### **Change User Password**

Select this option and press <Enter> to access the sub menu, and then type in the password.

### **Boot Sector Virus Protection**

This option is near the bottom of the Security Setup screen. Select "Disabled" to deactivate the Boot Sector Virus Protection. Select "Enabled" to enable boot sector protection. When "Enabled", AMI BIOS displays a warning when any program (or virus) issues a Disk Format command or attempts to write to the boot sector of the hard disk drive. The options are Enabled and **Disabled**.

## 7-6 Exit Menu

Select the Exit tab from AMI BIOS Setup Utility screen to enter the Exit BIOS Setup screen.

### **Save Changes and Exit**

When you have completed the system configuration changes, select this option to leave BIOS Setup and reboot the computer, so the new system configuration parameters can take effect. Select Save Changes and Exit from the Exit menu and press <Enter>.

### **Discard Changes and Exit**

Select this option to quit BIOS Setup without making any permanent changes to the system configuration and reboot the computer. Select Discard Changes and Exit from the Exit menu and press <Enter>.

### **Discard Changes**

Select this option and press <Enter> to discard all the changes and return to AMI BIOS Utility Program.

### **Load Optimal Defaults**

To set this feature, select Load Optimal Defaults from the Exit menu and press <Enter>. Then Select "OK" to allow BIOS to automatically load the Optimal Defaults as the BIOS Settings. The Optimal settings are designed for maximum system performance, but may not work best for all computer applications.

### **Load Fail-Safe Defaults**

To set this feature, select Load Fail-Safe Defaults from the Exit menu and press <Enter>. The Fail-Safe settings are designed for maximum system stability, but not maximum performance.

## Appendix A

### BIOS Error Beep Codes

During the POST (Power-On Self-Test) routines, which are performed each time the system is powered on, errors may occur.

**Non-fatal errors** are those which, in most cases, allow the system to continue the boot-up process. The error messages normally appear on the screen.

**Fatal errors** are those which will not allow the system to continue the boot-up procedure. If a fatal error occurs, you should consult with your system manufacturer for possible repairs.

These fatal errors are usually communicated through a series of audible beeps. The numbers on the fatal error list, on the following page, correspond to the number of beeps for the corresponding error. All errors listed, with the exception of Beep Code 8, are fatal errors.

POST codes may be read on the LEDs located beside the LAN port on the serverboard backplane. See the description of the POST code LEDs in Chapter 5.

#### A-1 AMIBIOS Error Beep Codes

<b>Beep Code</b>	<b>Error Message</b>	<b>Description</b>
1 beep	Refresh	Circuits have been reset. (Ready to power up.)
5 short, 1 long	Memory error	No memory detected in system
8 beeps	Display memory read/write error	Video adapter missing or with faulty memory

**Notes**

## Appendix B

### BIOS POST Checkpoint Codes

When AMIBIOS performs the Power On Self Test, it writes checkpoint codes to I/O port 0080h. If the computer cannot complete the boot process, diagnostic equipment can be attached to the computer to read I/O port 0080h.

#### B-1 Uncompressed Initialization Codes

The uncompressed initialization checkpoint codes are listed in order of execution:

Checkpoint	Code Description
D0h	The NMI is disabled. Power on delay is starting. Next, the initialization code checksum will be verified.
D1h	Initializing the DMA controller, performing the keyboard controller BAT test, starting memory refresh and entering 4 GB flat mode next.
D3h	Starting memory sizing next.
D4h	Returning to real mode. Executing any OEM patches and setting the Stack next.
D5h	Passing control to the uncompressed code in shadow RAM at E000:0000h. The initialization code is copied to segment 0 and control will be transferred to segment 0.

## B-2 Bootblock Recovery Codes

The bootblock recovery checkpoint codes are listed in order of execution:

Checkpoint	Code Description
E0h	The onboard floppy controller if available is initialized. Next, beginning the base 512 KB memory test.
E1h	Initializing the interrupt vector table next.
E2h	Initializing the DMA and Interrupt controllers next.
E6h	Enabling the floppy drive controller and Timer IRQs. Enabling internal cache memory.
Edh	Initializing the floppy drive.
Eeh	Looking for a floppy diskette in drive A:. Reading the first sector of the diskette.
Efh	A read error occurred while reading the floppy drive in drive A:.
F0h	Next, searching for the AMIBOOT.ROM file in the root directory.
F1h	The AMIBOOT.ROM file is not in the root directory.
F2h	Next, reading and analyzing the floppy diskette FAT to find the clusters occupied by the AMIBOOT.ROM file.
F3h	Next, reading the AMIBOOT.ROM file, cluster by cluster.
F4h	The AMIBOOT.ROM file is not the correct size.
F5h	Next, disabling internal cache memory.
FBh	Next, detecting the type of flash ROM.
FCh	Next, erasing the flash ROM.
FDh	Next, programming the flash ROM.
FFh	Flash ROM programming was successful. Next, restarting the system BIOS.

## B-3 Uncompressed Initialization Codes

The following runtime checkpoint codes are listed in order of execution.

These codes are uncompressed in F0000h shadow RAM.

Checkpoint	Code Description
03h	The NMI is disabled. Next, checking for a soft reset or a power on condition.
05h	The BIOS stack has been built. Next, disabling cache memory.
06h	Uncompressing the POST code next.
07h	Next, initializing the CPU and the CPU data area.
08h	The CMOS checksum calculation is done next.
0Ah	The CMOS checksum calculation is done. Initializing the CMOS status register for date and time next.
0Bh	The CMOS status register is initialized. Next, performing any required initialization before the keyboard BAT command is issued.
0Ch	The keyboard controller input buffer is free. Next, issuing the BAT command to the keyboard controller.
0Eh	The keyboard controller BAT command result has been verified. Next, performing any necessary initialization after the keyboard controller BAT command test.
0Fh	The initialization after the keyboard controller BAT command test is done. The keyboard command byte is written next.
10h	The keyboard controller command byte is written. Next, issuing the Pin 23 and 24 blocking and unblocking command.
11h	Next, checking if <End or <Ins> keys were pressed during power on. Initializing CMOS RAM if the Initialize CMOS RAM in every boot AMIBIOS POST option was set in AMIBCP or the <End> key was pressed.
12h	Next, disabling DMA controllers 1 and 2 and interrupt controllers 1 and 2.
13h	The video display has been disabled. Port B has been initialized. Next, initializing the chipset.
14h	The 8254 timer test will begin next.
19h	Next, programming the flash ROM.
1Ah	The memory refresh line is toggling. Checking the 15 second on/off time next.
2Bh	Passing control to the video ROM to perform any required configuration before the video ROM test.
2Ch	All necessary processing before passing control to the video ROM is done. Looking for the video ROM next and passing control to it.
2Dh	The video ROM has returned control to BIOS POST. Performing any required processing after the video ROM had control
23h	Reading the 8042 input port and disabling the MEGAKEY Green PC feature next. Making the BIOS code segment writable and performing any necessary configuration before initializing the interrupt vectors.
24h	The configuration required before interrupt vector initialization has completed. Interrupt vector initialization is about to begin.

Checkpoint	Code Description
25h	Interrupt vector initialization is done. Clearing the password if the POST DIAG switch is on.
27h	Any initialization before setting video mode will be done next.
28h	Initialization before setting the video mode is complete. Configuring the monochrome mode and color mode settings next.
2Ah	Bus initialization system, static, output devices will be done next, if present. See the last page for additional information.
2Eh	Completed post-video ROM test processing. If the EGA/VGA controller is not found, performing the display memory read/write test next.
2Fh	The EGA/VGA controller was not found. The display memory read/write test is about to begin.
30h	The display memory read/write test passed. Look for retrace checking next.
31h	The display memory read/write test or retrace checking failed. Performing the alternate display memory read/write test next.
32h	The alternate display memory read/write test passed. Looking for alternate display retrace checking next.
34h	Video display checking is over. Setting the display mode next.
37h	The display mode is set. Displaying the power on message next.
38h	Initializing the bus input, IPL, general devices next, if present. See the last page of this chapter for additional information.
39h	Displaying bus initialization error messages. See the last page of this chapter for additional information.
3Ah	The new cursor position has been read and saved. Displaying the Hit <DEL> message next.
3Bh	The Hit <DEL> message is displayed. The protected mode memory test is about to start.
40h	Preparing the descriptor tables next.
42h	The descriptor tables are prepared. Entering protected mode for the memory test next.
43h	Entered protected mode. Enabling interrupts for diagnostics mode next.
44h	Interrupts enabled if the diagnostics switch is on. Initializing data to check memory wraparound at 0:0 next.
45h	Data initialized. Checking for memory wraparound at 0:0 and finding the total system memory size next.
46h	The memory wraparound test is done. Memory size calculation has been done. Writing patterns to test memory next.
47h	The memory pattern has been written to extended memory. Writing patterns to the base 640 KB memory next.
48h	Patterns written in base memory. Determining the amount of memory below 1 MB next.
49h	The amount of memory below 1 MB has been found and verified.
4Bh	The amount of memory above 1 MB has been found and verified. Checking for a soft reset and clearing the memory below 1 MB for the soft reset next. If this is a power on situation, going to checkpoint 4Eh next.

Checkpoint	Code Description
4Ch	The memory below 1 MB has been cleared via a soft reset. Clearing the memory above 1 MB next.
4Dh	The memory above 1 MB has been cleared via a soft reset. Saving the memory size next. Going to checkpoint 52h next.
4Eh	The memory test started, but not as the result of a soft reset. Displaying the first 64 KB memory size next.
4Fh	The memory size display has started. The display is updated during the memory test. Performing the sequential and random memory test next.
50h	The memory below 1 MB has been tested and initialized. Adjusting the displayed memory size for relocation and shadowing next.
51h	The memory size display was adjusted for relocation and shadowing.
52h	The memory above 1 MB has been tested and initialized. Saving the memory size information next.
53h	The memory size information and the CPU registers are saved. Entering real mode next.
54h	Shutdown was successful. The CPU is in real mode. Disabling the Gate A20 line, parity, and the NMI next.
57h	The A20 address line, parity, and the NMI are disabled. Adjusting the memory size depending on relocation and shadowing next.
58h	The memory size was adjusted for relocation and shadowing. Clearing the Hit <DEL> message next.
59h	The Hit <DEL> message is cleared. The <WAIT...> message is displayed. Starting the DMA and interrupt controller test next.
60h	The DMA page register test passed. Performing the DMA Controller 1 base register test next.
62h	The DMA controller 1 base register test passed. Performing the DMA controller 2 base register test next.
65h	The DMA controller 2 base register test passed. Programming DMA controllers 1 and 2 next.
66h	Completed programming DMA controllers 1 and 2. Initializing the 8259 interrupt controller next.
67h	Completed 8259 interrupt controller initialization.
7Fh	Extended NMI source enabling is in progress.
80h	The keyboard test has started. Clearing the output buffer and checking for stuck keys. Issuing the keyboard reset command next.
81h	A keyboard reset error or stuck key was found. Issuing the keyboard controller interface test command next.
82h	The keyboard controller interface test completed. Writing the command byte and initializing the circular buffer next.
83h	The command byte was written and global data initialization has completed. Checking for a locked key next.
84h	Locked key checking is over. Checking for a memory size mismatch with CMOS RAM data next.
85h	The memory size check is done. Displaying a soft error and checking for a password or bypassing WINBIOS Setup next.

Checkpoint	Code Description
86h	The password was checked. Performing any required programming before WINBIOS Setup next.
87h	The programming before WINBIOS Setup has completed. Uncompressing the WINBIOS Setup code and executing the AMIBIOS Setup or WINBIOS Setup utility next.
88h	Returned from WINBIOS Setup and cleared the screen. Performing any necessary programming after WINBIOS Setup next.
89h	The programming after WINBIOS Setup has completed. Displaying the power on screen message next.
8Ch	Programming the WINBIOS Setup options next.
8Dh	The WINBIOS Setup options are programmed. Resetting the hard disk controller next.
8Fh	The hard disk controller has been reset. Configuring the floppy drive controller next.
91h	The floppy drive controller has been configured. Configuring the hard disk drive controller next.
95h	Initializing the bus option ROMs from C800 next. See the last page of this chapter for additional information.
96h	Initializing before passing control to the adaptor ROM at C800.
97h	Initialization before the C800 adaptor ROM gains control has completed. The adaptor ROM check is next.
98h	The adaptor ROM had control and has now returned control to BIOS POST. Performing any required processing after the option ROM returned control.
99h	Any initialization required after the option ROM test has completed. Configuring the timer data area and printer base address next.
9Ah	Set the timer and printer base addresses. Setting the RS-232 base address next.
9Bh	Returned after setting the RS-232 base address. Performing any required initialization before the Coprocessor test next.
9Ch	Required initialization before the Coprocessor test is over. Initializing the Coprocessor next.
9Dh	Coprocessor initialized. Performing any required initialization after the Coprocessor test next.
9Eh	Initialization after the Coprocessor test is complete. Checking the extended keyboard, keyboard ID, and Num Lock key next. Issuing the keyboard ID command next.
A2h	Displaying any soft errors next.
A3h	The soft error display has completed. Setting the keyboard typematic rate next.
A4h	The keyboard typematic rate is set. Programming the memory wait states next.
A5h	Memory wait state programming is over. Clearing the screen and enabling parity and the NMI next.
A7h	NMI and parity enabled. Performing any initialization required before passing control to the adaptor ROM at E000 next.
A8h	Initialization before passing control to the adaptor ROM at E000h completed. Passing control to the adaptor ROM at E000h next.

---

---

<b>Checkpoint</b>	<b>Code Description</b>
A9h	Returned from adaptor ROM at E000h control. Performing any initialization required after the E000 option ROM had control next.
Aah	Initialization after E000 option ROM control has completed. Displaying the system configuration next.
Abh	Uncompressing the DMI data and executing DMI POST initialization next.
B0h	The system configuration is displayed.
B1h	Copying any code to specific areas.
00h	Code copying to specific areas is done. Passing control to INT 19h boot loader next.

## Notes

## Appendix C

# System Specifications

### Processors

Single AMD Opteron™ 200 Series 64-bit processors in 940-pin micro PGA ZIF sockets

**Note:** Please refer to our web site for a complete listing of supported processors.

### Chipset

ServerWorks HT-2000/1000

### BIOS

8 Mb Phoenix® Flash ROM

### Memory Capacity

Four 184-pin DIMM sockets supporting up to 16 GB of registered ECC DDR333/266 or up to 8 GB of registered ECC DDR400 SDRAM

**Note:** See the memory section in Chapter 5 for details.

### SCSI Controller (1010P-8/8R, H8SSP-8 only)

AIC-7902W for dual channel Ultra320 SCSI

### Drive Bays

Four (4) hot-swap drive bays to house four (4) standard SCSI/SATA drives

### Peripheral Drives/Bays

One (1) slim floppy drive

One (1) slim DVD/CD-ROM drive

### Expansion Slots

Supports the use of one standard size 133 MHz PCI-X or PCI-Express x8 add-on card and one low profile 100 MHz PCI-X or PCI-Express x8 add-on card (with included riser cards, see Section 5-6 for details)

### Serverboard

Model: H8SSP-8 (1010P-8/8R) or H8SSP-i (1010P-T/TR), proprietary form factor

Dimensions: 16.235" x 11.24" (412 x 285 mm)

### **Chassis (1010P-8)**

1010P-8: SC816S-400 (1U rackmount)

1010P-8R: SC816S-R400 (1U rackmount)

1010P-T: SC816T-400 (1U rackmount)

1010P-TR: SC816T-R400 (1U rackmount)

Dimensions: (HxWxD) 1.7 x 17.2 x 27 in. (43 x 437 x 686 mm)

### **Weight**

1010P-8/T Gross (Bare Bone): 57 lbs. (25.9 kg.)

1010P-8R/TR Gross (Bare Bone): 60 lbs. (27.3 kg.)

### **System Cooling**

Three (3) paired sets of 4-cm counter-rotating cooling fans (fan speed controlled by BIOS setting)

### **System Input Requirements**

AC Input Voltage: 100-240 VAC

Rated Input Current: 10A (115V) to 5A (230V)

Rated Input Frequency: 50-60 Hz

### **PFC Power Supply (ratings apply to each module)**

(1010P-8R/TR: two power supply modules, 1010P-8/T: one power supply module)

Rated Output Power: 400W (Model# SP400-1R, Part# PWS-0064)

Rated Output Voltages: +3.3V (21A), +5V (24A), +12V<sub>ALL</sub> (32A), -12V (0.6A), +5Vsb (4A)

### **Operating Environment**

Operating Temperature: 10° to 35° C (50° to 95° F)

Non-Operating Temperature: -40° to 70° C (-40° to 158° F)

Operating Relative Humidity: 8% to 90% (non-condensing)

Non-Operating Relative Humidity: 5 to 95% (non-condensing)

## **Regulatory Compliance**

### Electromagnetic Emissions:

EN 55022, EN 61000-3-2/-3-3, CISPR 22

### Electromagnetic Immunity:

EN 55024/CISPR 24, (EN 61000-4-2, EN 61000-4-3, EN 61000-4-4,  
EN 61000-4-5, EN 61000-4-6, EN 61000-4-8, EN 61000-4-11)

### Safety:

EN 60950/IEC 60950-Compliant

UL Listed (USA)

CUL Listed (Canada)

TUV Certified (Germany)

CE Marking (Europe)

## Notes