

SUPERO®

AS1011S-MR2

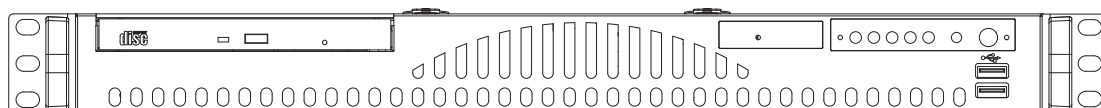

USER'S MANUAL

1.0a

The information in this User's Manual has been carefully reviewed and is believed to be accurate. The vendor assumes no responsibility for any inaccuracies that may be contained in this document, makes no commitment to update or to keep current the information in this manual, or to notify any person or organization of the updates. **Please Note: For the most up-to-date version of this manual, please see our web site at www.supermicro.com.**

Super Micro Computer, Inc. ("Supermicro") reserves the right to make changes to the product described in this manual at any time and without notice. This product, including software, if any, and documentation may not, in whole or in part, be copied, photocopied, reproduced, translated or reduced to any medium or machine without prior written consent.

IN NO EVENT WILL SUPERMICRO BE LIABLE FOR DIRECT, INDIRECT, SPECIAL, INCIDENTAL, SPECULATIVE OR CONSEQUENTIAL DAMAGES ARISING FROM THE USE OR INABILITY TO USE THIS PRODUCT OR DOCUMENTATION, EVEN IF ADVISED OF THE POSSIBILITY OF SUCH DAMAGES. IN PARTICULAR, SUPERMICRO SHALL NOT HAVE LIABILITY FOR ANY HARDWARE, SOFTWARE, OR DATA STORED OR USED WITH THE PRODUCT, INCLUDING THE COSTS OF REPAIRING, REPLACING, INTEGRATING, INSTALLING OR RECOVERING SUCH HARDWARE, SOFTWARE, OR DATA.

Any disputes arising between manufacturer and customer shall be governed by the laws of Santa Clara County in the State of California, USA. The State of California, County of Santa Clara shall be the exclusive venue for the resolution of any such disputes. Super Micro's total liability for all claims will not exceed the price paid for the hardware product.

FCC Statement: This equipment has been tested and found to comply with the limits for a Class A digital device pursuant to Part 15 of the FCC Rules. These limits are designed to provide reasonable protection against harmful interference when the equipment is operated in a commercial environment. This equipment generates, uses, and can radiate radio frequency energy and, if not installed and used in accordance with the manufacturer's instruction manual, may cause harmful interference with radio communications. Operation of this equipment in a residential area is likely to cause harmful interference, in which case you will be required to correct the interference at your own expense.

California Best Management Practices Regulations for Perchlorate Materials: This Perchlorate warning applies only to products containing CR (Manganese Dioxide) Lithium coin cells. "Perchlorate Material-special handling may apply. See www.dtsc.ca.gov/hazardouswaste/perchlorate"

WARNING: Handling of lead solder materials used in this product may expose you to lead, a chemical known to the State of California to cause birth defects and other reproductive harm.

Manual Revision 1.0a
Release Date: October 10, 2008

Unless you request and receive written permission from Super Micro Computer, Inc., you may not copy any part of this document.

Information in this document is subject to change without notice. Other products and companies referred to herein are trademarks or registered trademarks of their respective companies or mark holders.

Copyright © 2008 by Super Micro Computer, Inc.
All rights reserved.
Printed in the United States of America

Preface

About This Manual

This manual is written for professional system integrators and PC technicians. It provides information for the installation and use of the AS1011S-MR2 server. Installation and maintenance should be performed by experienced technicians only.

The AS1011S-MR2 is a high-end server based on the SC512F-260 1U rack-mount chassis and the H8SSL-i2, a single processor motherboard that supports AMD Opteron 1000 series processors and up to 8 GB of ECC/non-ECC DDR2-800/667/533 SDRAM.

Manual Organization

Chapter 1: Introduction

The first chapter provides a checklist of the main components included with the server system and describes the main features of the H8SSL-i2 motherboard and the SC512F-260 chassis, which comprise the 1011S-MR2.

Chapter 2: Server Installation

This chapter describes the steps necessary to install the 1011S-MR2 into a rack and check out the server configuration prior to powering up the system. If your server was ordered without processor and memory components, this chapter will refer you to the appropriate sections of the manual for their installation.

Chapter 3: System Interface

Refer here for details on the system interface, which includes the functions and information provided by the control panel on the chassis as well as other LEDs located throughout the system.

Chapter 4: System Safety

You should thoroughly familiarize yourself with this chapter for a general overview of safety precautions that should be followed when installing and servicing the 1011S-MR2.

Chapter 5: Advanced Motherboard Setup

Chapter 5 provides detailed information on the H8SSL-i2 motherboard, including the locations and functions of connections, headers and jumpers. Refer to this chapter when adding or removing processors or main memory and when reconfiguring the motherboard.

Chapter 6: Advanced Chassis Setup

Refer to Chapter 6 for detailed information on the SC512F-260 server chassis. You should follow the procedures given in this chapter when installing, removing or reconfiguring SATA or peripheral drives and when replacing the system power supply and cooling fan.

Chapter 7: BIOS

The BIOS chapter includes an introduction to BIOS and provides detailed information on running the CMOS Setup Utility.

Appendix A: BIOS Error Beep Codes

Appendix B: BIOS POST Checkpoint Codes

Appendix C: System Specifications

Notes

Table of Contents

Preface

About This Manual	iii
Manual Organization	iii

Chapter 1: Introduction

1-1 Overview	1-1
1-2 Motherboard Features	1-2
1-3 Server Chassis Features	1-5
1-4 Contacting Supermicro	1-6

Chapter 2: Server Installation

2-1 Overview	2-1
2-2 Unpacking the System	2-1
2-3 Preparing for Setup	2-1
2-4 Installing the System into a Rack	2-4
2-5 Checking the Motherboard Setup	2-8
2-6 Checking the Drive Bay Setup	2-11

Chapter 3: System Interface

3-1 Overview	3-1
3-2 Control Panel Buttons	3-1
Reset	3-1
Power	3-1
3-3 Control Panel LEDs	3-2
Overheat/Fan Fail	3-2
NIC2	3-2
NIC1	3-2
HDD	3-2
Power	3-3

Chapter 4: System Safety

4-1 Electrical Safety Precautions	4-1
4-2 General Safety Precautions	4-2
4-3 ESD Precautions	4-3
4-4 Operating Precautions	4-4

Chapter 5: Advanced Motherboard Setup

5-1	Handling the Motherboard	5-1
5-2	Mounting the Motherboard into a Chassis	5-2
5-3	Processor and Heatsink Installation	5-2
5-4	Connecting Cables	5-5
	Connecting Data Cables	5-5
	Connecting Power Cables	5-5
	Connecting the Control Panel	5-6
5-5	I/O Ports	5-7
5-6	Installing Memory	5-7
5-7	Adding PCI Cards	5-9
5-8	Motherboard Details	5-10
	H8SSL-i2 Layout	5-10
	H8SSL-i2 Quick Reference	5-11
5-9	Connector Definitions	5-12
	Primary ATX Power Connector	5-12
	Secondary Power Connector	5-12
	NMI Button	5-12
	Power LED	5-12
	HDD LED	5-13
	NIC1 LED	5-13
	NIC2 LED	5-13
	Overheat/Fan Fail LED	5-13
	Power Fail LED	5-13
	Reset Button	5-14
	Power Button	5-14
	USB0/1 (Universal Serial Bus Ports)	5-14
	Serial ATA Activity LEDs	5-14
	USB2/3 Headers	5-15
	Serial Ports	5-15
	Fan Headers	5-15
	Overheat LED	5-15
	Power LED/Speaker	5-16
	ATX PS/2 Keyboard and Mouse Ports	5-16
	Wake-On-Ring	5-16
	Wake-On-LAN	5-16
	LAN1/2 (Ethernet Ports)	5-17
	Chassis Intrusion	5-17
	Power I ² C Header	5-17

Power Supply Fail Alarm Header	5-17
Power Supply Fail Alarm Reset Header	5-17
5-10 Jumper Settings	5-18
Explanation of Jumpers	5-18
CMOS Clear	5-18
Onboard Speaker Enable/Disable	5-19
PCI-X Slot Speed	5-19
VGA Enable/Disable	5-19
LAN Enable/Disable	5-19
Watch Dog Enable/Disable	5-20
Power Force On Enable/Disable	5-20
I ² C Enable/Disable	5-20
5-11 Onboard Indicators	5-21
LAN1/LAN2 LEDs	5-21
SATA Activity LEDs	5-21
Onboard Power LED	5-21
5-12 Floppy, IDE and SATA Drive Connections	5-22
Floppy Connector	5-22
IDE Connector	5-23
SATA Ports	5-23
5-13 Enabling SATA RAID	5-24

Chapter 6: Advanced Chassis Setup

6-1 Static-Sensitive Devices	6-1
6-2 Control Panel	6-2
6-3 System Fans	6-2
System Fan Failure	6-3
Replacing System Cooling Fans	6-3
6-4 Drive Bay Installation/Removal	6-4
Serial ATA Drive Installation	6-4
CD-ROM Drive Installation	6-5
6-5 Power Supply	6-6
Power Supply Failure	6-6
Replacing the Power Supply	6-6

Chapter 7: BIOS

7-1 Introduction	7-1
7-2 Main Menu	7-2
7-3 Advanced Settings Menu	7-2
7-4 Boot Menu	7-13

7-5	Security Menu	7-13
7-6	Exit Menu	7-14

Appendices:

Appendix A:	BIOS Error Beep Codes	A-1
Appendix B:	BIOS POST Checkpoint Codes	B-1
Appendix C:	System Specifications	C-1

Notes

Chapter 1

Introduction

1-1 Overview

The AS1011S-MR2 is a high-end single processor, mini 1U rackmount server. The 1011S-MR2 is comprised of two main subsystems: the SC512F-260 chassis and the H8SSL-i2 motherboard. The H8SSL-i2 supports a single AMD Opteron 1000 series processor in a 940-pin AM2 socket and up to 8 GB of ECC/non-ECC DDR2-800/667/533 SDRAM memory. Please refer to our web site for information on operating systems that have been certified for use with the 1011S-MR2 and for regular updates on supported processor speeds.

In addition to the motherboard and chassis, various hardware components may have been included with the 1011S-MR2, as listed below.

- One (1) slim CD-ROM drive (CDM-TEAC-24)
- One (1) SATA cable (CBL-0178L)
- Two (2) 4-cm counter-rotating fans (FAN-0087)
- One (1) air shroud (MCP-310-00027-01)
- One (1) passive heatsink for AM2 CPU (SNK-P0026)
- One (1) 3.3V 64-bit, 66 MHz PCI-X slot riser card (CSE-RR1U-X)
- Rackmount hardware with screws (CSE-PT8) (optional):
 - Two (2) rack rail assemblies
 - Six (6) brackets for mounting the rack rails in a rack/telco rack
- One (1) CD containing drivers and utilities

1-2 Motherboard Features

At the heart of the 1011S-MR2 lies the H8SSL-i2, a single processor motherboard designed to provide maximum performance. Below are the main features of the H8SSL-i2. (See Figure 1-1 for a block diagram of the ServerWorks HT-1000 chipset.)

Processors

The H8SSL-i2 has a 940-pin AM2 type socket that supports a single AMD Opteron Series 1000 processor. Please refer to the support section of our web site for a complete listing of supported processors.

Memory

The H8SSL-i2 has four (4) 240-pin DIMM sockets that can support up to 8 GB of ECC/non-ECC DDR2-800/667/533 SDRAM. (Memory can operate in either single or dual dual-channel mode.)

Serial ATA

A Serial ATA controller is incorporated into the ServerWorks HT-1000 chipset. The single Serial ATA drive in the 1011S-MR2 is not hot-swappable. No RAID is supported due to the single hard drive configuration.

PCI Expansion Slots

The H8SSL-i2 has one 64-bit, 133 MHz (3.3V) PCI-X slot and two 32-bit, 33 MHz (5V) PCI slots. When incorporated into the 1011S-MR2 server system, a riser card (CSE-RR1U-X) is included for use with the PCI-X slot to support one full-height, half-length expansion card in the 133 MHz PCI-X slot.

Ethernet Ports

A Broadcom BCM5704 Ethernet controller is incorporated into the H8SSL-i2 to support two Gigabit LAN ports.

Graphics Controller

The 1011S-MR2 features an integrated video controller based on the ES1000 graphics chip. The ES1000 was designed specifically for servers, featuring low power consumption, high reliability and superior longevity.

Onboard Controllers/Ports

An onboard IDE controller supports one floppy drive and one Ultra ATA 100 hard drive or ATAPI device. Onboard I/O backpanel ports include one serial COM port, two USB ports, a VGA (monitor) port, PS/2 mouse and keyboard ports and two GLAN (RJ45) ports.

Other Features

Other onboard features that promote system health include voltage monitors, a chassis intrusion header, auto-switching voltage regulators, chassis and CPU overheat sensors, virus protection and BIOS rescue.

**Figure 1-1. ServerWorks HT-1000 Chipset:
System Block Diagram**

Note: This is a general block diagram. Please see Chapter 5 for details.

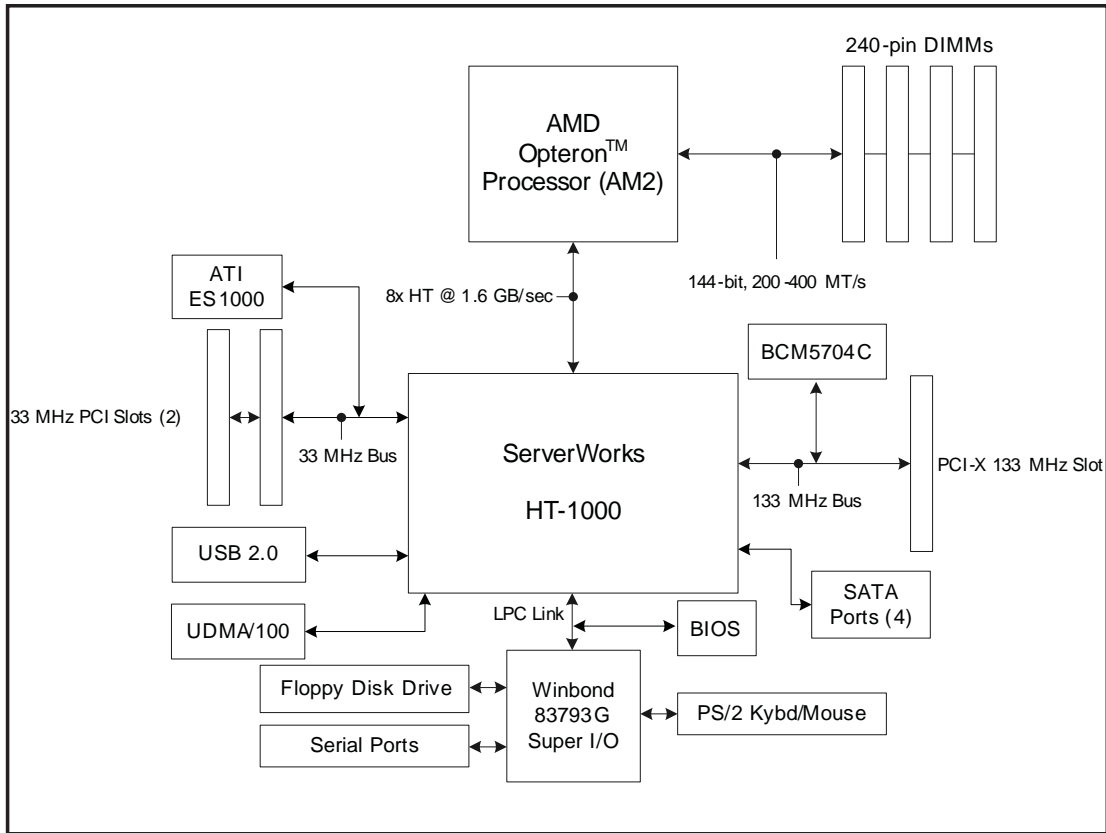

1-3 Server Chassis Features

The 1011S-MR2 is a mini 1U rackmount server platform configuration. The following is a general outline of the main features of the SC512F-260 chassis.

System Power

When configured as a 1011S-MR2, the SC512F-260 chassis includes a single 260W power supply.

Control Panel

The SC512F-260's control panel provides important system monitoring and control information. LEDs indicate power on, network activity, hard disk drive activity, overheat warning and fan failure. The control panel also includes a main power button and a system reset button.

Rear I/O Panel

The rear I/O panel on the SC512F-260 provides one motherboard expansion slot, one COM port (another is internal), two USB ports, PS/2 mouse and keyboard ports, a VGA (graphics) port and two Gb Ethernet ports. (See Chapter 6 for diagram.)

Cooling System

The SC512F-260/SC513F-260 chassis has an innovative cooling design that features an air shroud and two sets of counter-rotating fans with user-defined fan speed control.

1-4 Contacting Supermicro

Headquarters

Address: Super Micro Computer, Inc.
980 Rock Ave.
San Jose, CA 95131 U.S.A.

Tel: +1 (408) 503-8000

Fax: +1 (408) 503-8008

Email: marketing@supermicro.com (General Information)
support@supermicro.com (Technical Support)

Web Site: www.supermicro.com

Europe

Address: Super Micro Computer B.V.
Het Sterrenbeeld 28, 5215 ML
's-Hertogenbosch, The Netherlands

Tel: +31 (0) 73-6400390

Fax: +31 (0) 73-6416525

Email: sales@supermicro.nl (General Information)
support@supermicro.nl (Technical Support)
rma@supermicro.nl (Customer Support)

Asia-Pacific

Address: Super Micro Computer, Inc.
4F, No. 232-1, Liancheng Rd.
Chung-Ho 235, Taipei, Taiwan, R.O.C.

Tel: +886-(2) 8226-3990

Fax: +886-(2) 8226-3991

Web Site: www.supermicro.com.tw

Technical Support:

Email: support@supermicro.com.tw

Tel: 886-2-8228-1366, ext.132 or 139

Chapter 2

Server Installation

2-1 Overview

This chapter provides a quick setup checklist to get your 1011S-MR2 up and running. Following the steps in the order given should enable you to have the system operational within a minimal amount of time. This quick setup assumes that your 1011S-MR2 system has come to you with the processor and memory preinstalled. If your system is not already fully integrated with a motherboard, processor, system memory etc., please turn to the chapter or section noted in each step for details on installing specific components.

2-2 Unpacking the System

You should inspect the box the 1011S-MR2 was shipped in and note if it was damaged in any way. If the server itself shows damage, you should file a damage claim with the carrier who delivered it.

Decide on a suitable location for the rack unit that will hold the 1011S-MR2. It should be situated in a clean, dust-free area that is well ventilated. Avoid areas where heat, electrical noise and electromagnetic fields are generated. You will also need it placed near a grounded power outlet. Read the Rack and Server Precautions in the next section.

2-3 Preparing for Setup

The 1011S-MR2 does not ship with a rack rail hardware package as the system can be rack mounted without the use of rails. An optional rack rail package is available if you wish to order from Supermicro. Follow the steps in the order given to complete the installation process in a minimal amount of time. Please read this section in its entirety before you begin the installation procedure outlined in the sections that follow.

Choosing a Setup Location

- Leave enough clearance in front of the rack to enable you to open the front door completely (~25 inches).
- Leave approximately 30 inches of clearance in the back of the rack to allow for sufficient airflow and ease in servicing.
- This product is for installation only in a Restricted Access Location (dedicated equipment rooms, service closets and the like).



Warnings and Precautions!



Rack Precautions

- Ensure that the leveling jacks on the bottom of the rack are fully extended to the floor with the full weight of the rack resting on them.
- In a single rack installation, stabilizers should be attached to the rack.
- In multiple rack installations, the racks should be coupled together.
- Always make sure the rack is stable before extending a component from the rack.
- You should extend only one component at a time - extending two or more simultaneously may cause the rack to become unstable.

Server Precautions

- Review the electrical and general safety precautions in Chapter 4.
- Determine the placement of each component in the rack *before* you install the rails.
- Install the heaviest server components on the bottom of the rack first, and then work up.
- Use a regulating uninterruptible power supply (UPS) to protect the server from power surges, voltage spikes and to keep your system operating in case of a power failure.
- Allow the power supply units to cool before touching them.
- Always keep the rack's front door and all panels and components on the servers closed when not servicing to maintain proper cooling.

Rack Mounting Considerations

Ambient Operating Temperature

If installed in a closed or multi-unit rack assembly, the ambient operating temperature of the rack environment may be greater than the ambient temperature of the room. Therefore, consideration should be given to installing the equipment in an environment compatible with the manufacturer's maximum rated ambient temperature (T_{mra}).

Reduced Airflow

Equipment should be mounted into a rack so that the amount of airflow required for safe operation is not compromised.

Mechanical Loading

Equipment should be mounted into a rack so that a hazardous condition does not arise due to uneven mechanical loading.

Circuit Overloading

Consideration should be given to the connection of the equipment to the power supply circuitry and the effect that any possible overloading of circuits might have on overcurrent protection and power supply wiring. Appropriate consideration of equipment nameplate ratings should be used when addressing this concern.

Reliable Ground

A reliable ground must be maintained at all times. To ensure this, the rack itself should be grounded. Particular attention should be given to power supply connections other than the direct connections to the branch circuit (i.e. the use of power strips, etc.).

2-4 Installing the System into a Rack (Rack hardware optional)

This section provides information on installing the 1011S-MR2 into a rack unit. If the system has already been mounted into a rack, you can skip ahead to Sections 2-5 and 2-6.

Basic Installation Procedure

The 1011S-MR2 server comes with two rack mounting brackets, which are located on each side at the front of the chassis. To mount the system into a rack, simply screw these brackets directly to the front of the rack (two screws for each bracket). As Figure 2-1 shows, the brackets can be located at the front of the chassis (left figure) or moved approximately one-third to the rear of the chassis (right figure).

Figure 2-1. Installing the Server into a Rack: Basic

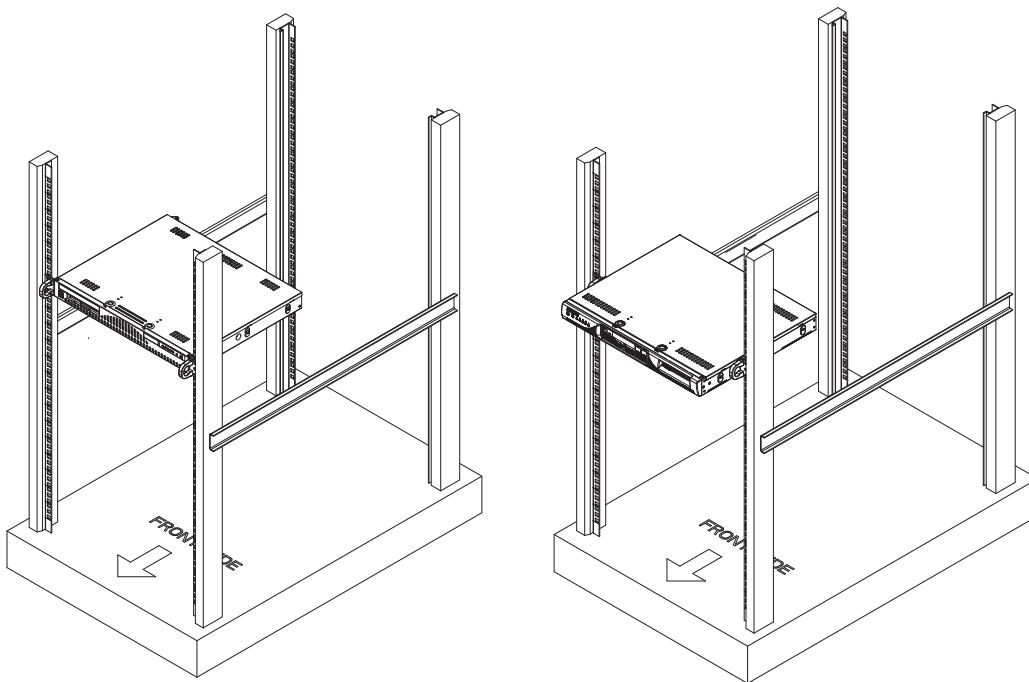

Installing with Rackmount Kit

This section is only for customers that have the optional rack mount kit (CSE-PT8). Each of these assemblies consist of two sections: an inner rail that secures to the chassis and an outer rail that secures directly to the rack itself (see Figure 2-2). This is a guideline for installing the unit into a rack with the optional rack kit. You should also refer to the installation instructions that came with the rack unit you are using. Be aware that there are a variety of rack units on the market, which may mean the assembly procedure will differ slightly.

Installing the Chassis Rails

The two rail sections must be detached from each other prior to installation. Do this by depressing the locking tab on the inner rail to release it from its locked position then pull the two rails completely apart. Do this for both the left and right side rack rail assemblies.

Position the fixed chassis rail sections you just removed along the side of the chassis making sure the three screw holes line up. Note that these two rails are left/right specific. Screw the rail securely to the side of the chassis (see Figure 2-2). Repeat this procedure for the other rail on the other side of the chassis. You will also need to attach the rail brackets when installing into a telco rack.

Locking Tabs: Both chassis rails have a locking tab, which serves two functions. The first is to lock the server into place when installed and pushed fully into the rack, which is its normal position. Secondly, these tabs also lock the server in place when fully extended from the rack. This prevents the server from coming completely out of the rack when you pull it out for servicing.

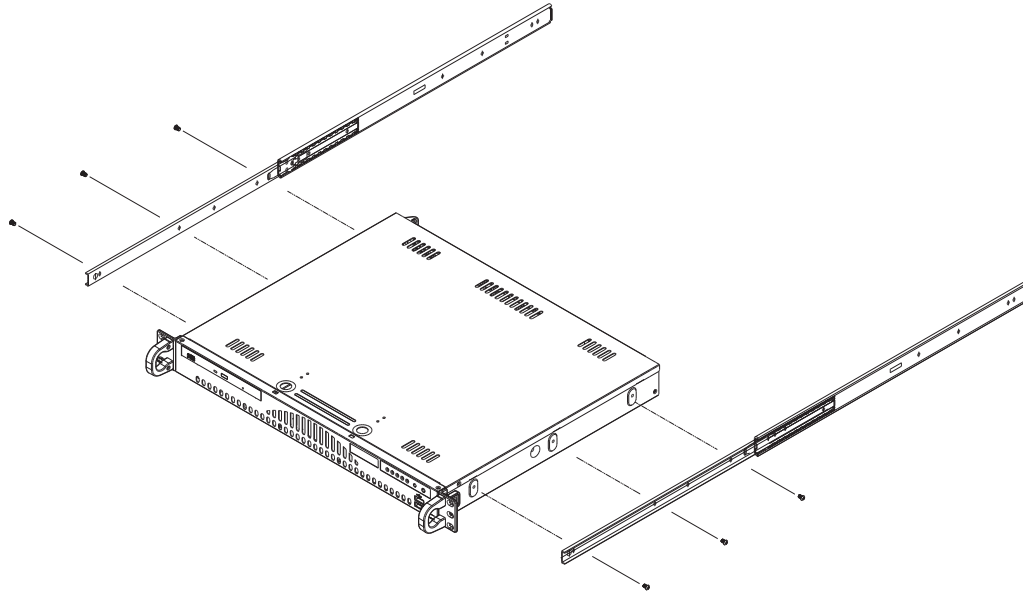
Figure 2-2. Installing Chassis Rails

Installing the Rack Rails

Determine where you want to place the 1011S-MR2 in the rack ([see Rack and Server Precautions in Section 2-3](#)). Position the fixed rack rail/sliding rail guide assemblies at the desired location in the rack, keeping the sliding rail guide facing the inside of the rack. Screw the assembly securely to the rack using the brackets provided. Attach the other assembly to the other side of the rack, making sure that both are at the exact same height and with the rail guides facing inward.

Installing the Server into the Rack

You should now have rails attached to both the chassis and the rack unit. The next step is to install the server into the rack. Do this by lining up the rear of the chassis rails with the front of the rack rails. Slide the chassis rails into the rack rails, keeping the pressure even on both sides (you may have to depress the locking tabs when inserting). See Figure 2-3.

When the server has been pushed completely into the rack, you should hear the locking tabs "click". Finish by inserting and tightening the thumbscrews that hold the front of the server to the rack.

**Figure 2-3. Installing the Server into a Rack
(w/ Optional Rackmount Kit)**

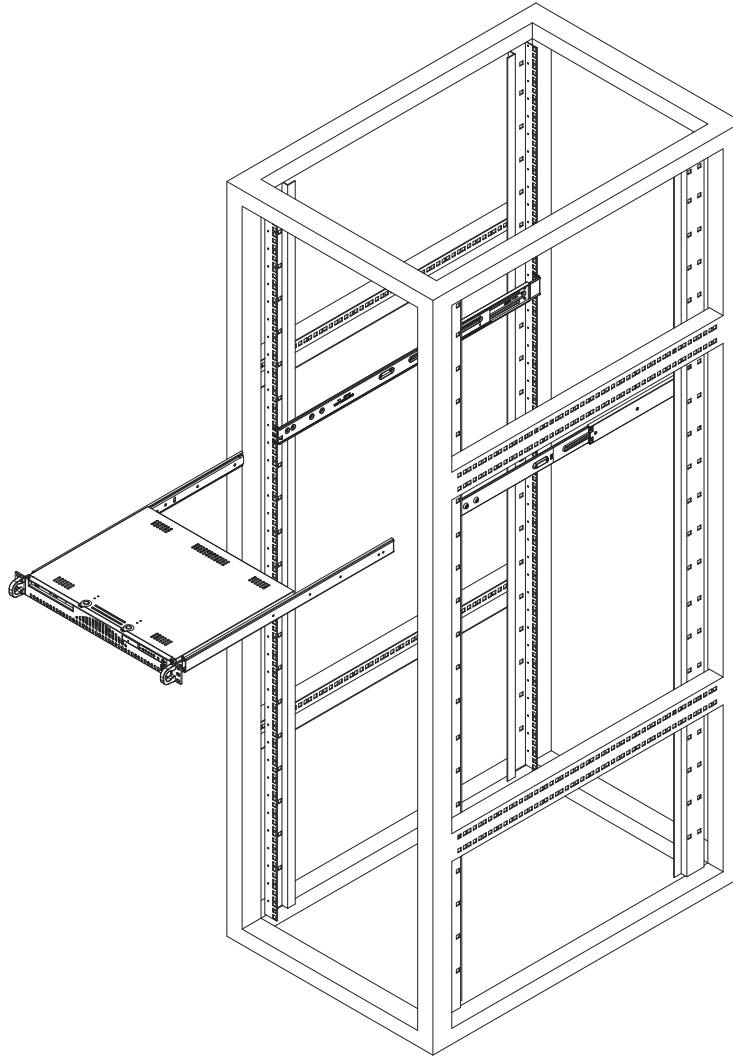

Installing the Server into a Telco Rack

If you are installing the 1011S-MR2 into a Telco type rack, follow the directions given on the previous pages for rack installation. The only difference in the installation procedure will be the positioning of the rack brackets to the rack. They should be spaced apart just enough to accommodate the width of the telco rack.

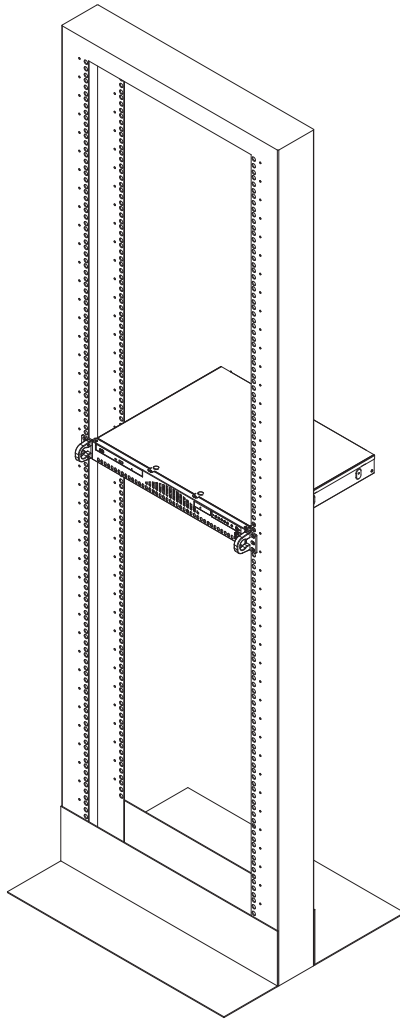
Figure 2-4. Installing the Server into a Telco Rack: Basic

2-5 Checking the Motherboard Setup

After you install the 1011S-MR2 in the rack, you will need to open the unit to make sure the motherboard is properly installed and all the connections have been made.

1. Accessing the inside of the server (Figure 2-6)

First, release the retention screws that secure the unit to the rack. Grasp the two handles on either side and pull the unit straight out until it locks (you will hear a "click"). Then, remove the screws from the lips on either side of the chassis top cover (see Figure 2-6 for location). Next, depress the two buttons on the top

**Figure 2-5. Installing the Server into a Telco Rack
(w/ Optional Rackmount Kit)**

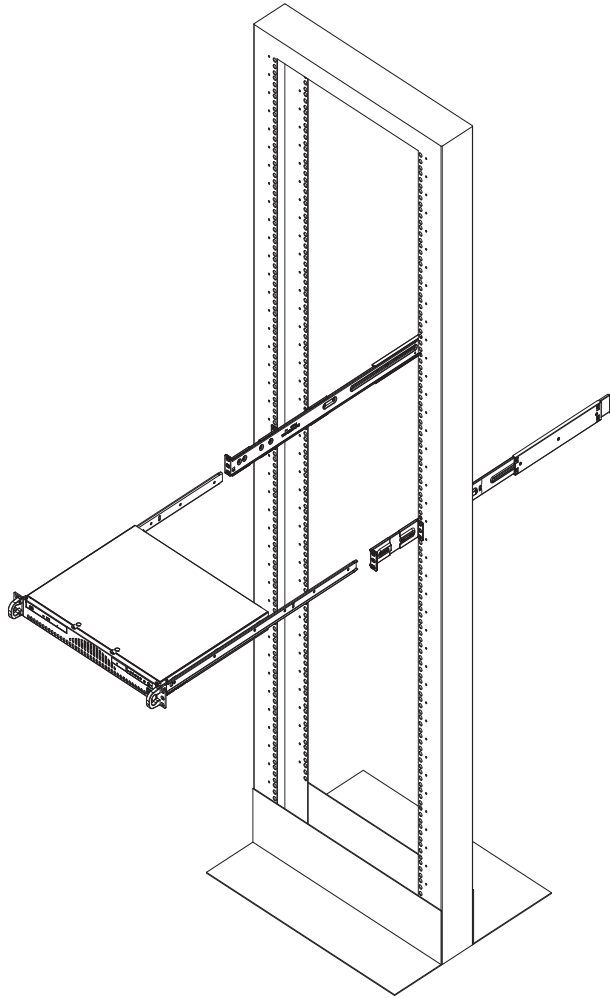

of the chassis to release the top cover while pushing the cover away from you until it stops. You can then lift the top cover from the chassis to gain full access to the inside of the server.

2. Check the CPU (processor)

You may have a processor already installed into the system board. The processor should have its own heatsink attached. See Chapter 5 for instructions on processor installation.

3. Check the system memory

Your 1011S-MR2 server system may have come with system memory already installed. Make sure all DIMMs are fully seated in their slots. For details on adding system memory, refer to Chapter 5.

4. Installing add-on cards

If desired, you can install an add-on card to the system. See Chapter 5 for details on installing a PCI add-on card.

5. Check all cable connections and airflow

Make sure all power and data cables are properly connected and not blocking the airflow. See Chapter 5 for details on cable connections. Also, check that the air shroud is properly installed.

Figure 2-6. Accessing the Inside of the Server

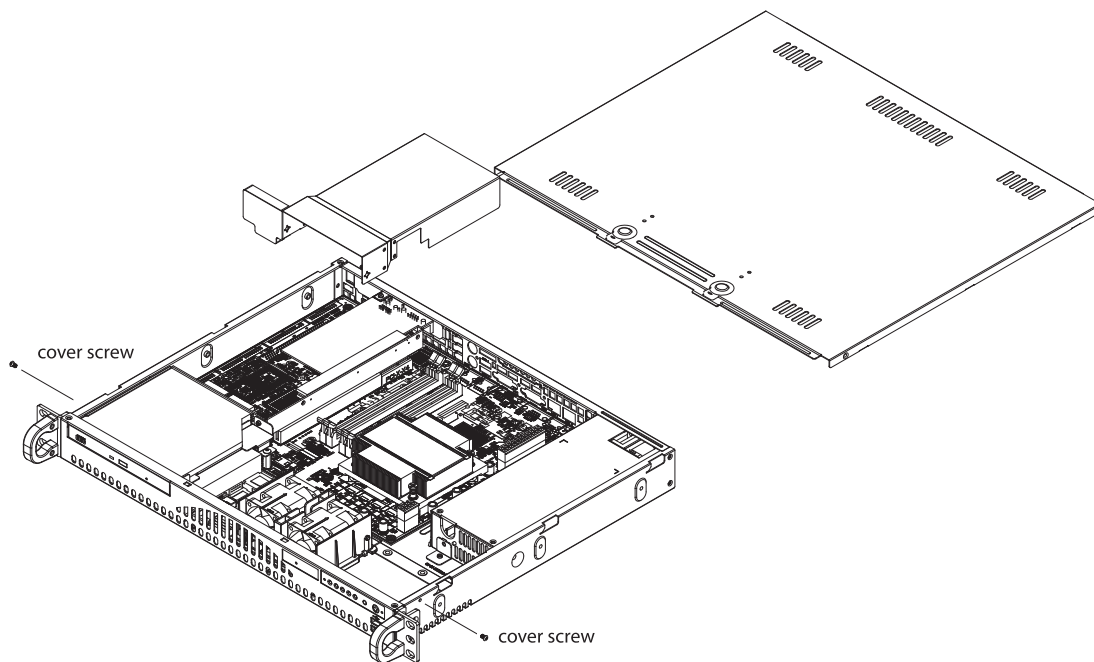

2-6 Checking the Drive Bay Setup

Next, you should check to make sure the peripheral drives and the Serial ATA drive have been properly installed and all essential connections have been made.

1. Accessing the drive bays

For servicing the Serial ATA, CD-ROM and floppy drives, you will need to remove the top chassis cover. The Serial ATA disk drive is located at the front right side of the chassis.

2. Installing a CD-ROM and floppy disk drives

Refer to Chapter 6 if you need to reinstall a CD-ROM and/or floppy disk drive to the system.

3. Check the Serial ATA disk drives

Depending upon your system's configuration, your system may have a Serial ATA hard drive already installed. If you need to install a Serial ATA hard drive, please refer to the appropriate section in Chapter 6.

4. Check the airflow

Airflow is provided by two sets of 4-cm counter-rotating fans. The system component layout was carefully designed to promote sufficient airflow through the small 1U rackmount space. Also note that all power and data cables have been routed in such a way that they do not block the airflow generated by the fan.

5. Supplying power to the system

The last thing you must do is to provide input power to the system. Plug the power cord from the power supply unit into a high-quality power strip that offers protection from electrical noise and power surges. It is recommended that you use an uninterruptible power supply (UPS).

Notes

Chapter 3

System Interface

3-1 Overview

There are several LEDs on the control panel to keep you constantly informed of the overall status of the system as well as the activity and health of specific components. There are also two buttons on the chassis control panel. This chapter explains the meanings of all LED indicators and the appropriate response you may need to take.

3-2 Control Panel Buttons

There are two push-buttons located on the front of the chassis. These are (in order from left to right) a reset button and a power on/off button.

RESET

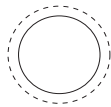

- **Reset:** The reset button reboots the system.

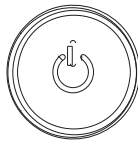

- **Power:** This is the main power button, which is used to apply or turn off the main system power. Turning off system power with this button removes the main power but keeps standby power supplied to the system.

3-3 Control Panel LEDs

The control panel located on the front of the SC512F-260 chassis has five LEDs. These LEDs provide you with critical information related to different parts of the system. This section explains what each LED indicates when illuminated and any corrective action you may need to take.



- **Overheat/Fan Fail:** When this LED flashes it indicates a fan failure. When on continuously (on and not flashing) it indicates an overheat condition, which may be caused by cables obstructing the airflow in the system or the ambient room temperature being too warm. Check the routing of the cables and make sure all fans are present and operating normally. You should also check to make sure that the chassis covers are installed. Finally, verify that the heatsinks are installed properly (see Chapter 5). This LED will remain flashing or on as long as the overheat condition exists.



- **NIC2:** Indicates network activity on GLAN2 when flashing .



- **NIC1:** Indicates network activity on GLAN1 when flashing.



- **HDD:** Channel activity for HDDs. This light indicates CD-ROM drive activity when flashing.



- **Power:** Indicates power is being supplied to the system's power supply units. This LED should normally be illuminated when the system is operating.

Notes

Chapter 4

System Safety

4-1 Electrical Safety Precautions



Basic electrical safety precautions should be followed to protect yourself from harm and the 1011S-MR2 from damage:

- Be aware of the locations of the power on/off switch on the chassis as well as the room's emergency power-off switch, disconnection switch or electrical outlet. If an electrical accident occurs, you can then quickly remove power from the system.
- Do not work alone when working with high voltage components.
- Power should always be disconnected from the system when removing or installing main system components, such as the motherboard, memory modules and floppy drive. When disconnecting power, you should first power down the system with the operating system first and then unplug the power cords of all the power supply units in the system.
- When working around exposed electrical circuits, another person who is familiar with the power-off controls should be nearby to switch off the power if necessary.
- Use only one hand when working with powered-on electrical equipment. This is to avoid making a complete circuit, which will cause electrical shock. Use extreme caution when using metal tools, which can easily damage any electrical components or circuit boards they come into contact with.
- Do not use mats designed to decrease static electrical discharge as protection from electrical shock. Instead, use rubber mats that have been specifically designed as electrical insulators.
- The power supply power cords must include a grounding plug and must be plugged into grounded electrical outlets.

- **Motherboard Battery: CAUTION** - There is a danger of explosion if the onboard battery is installed upside down, which will reverse its polarities (see Figure 4-1). This battery must be replaced only with the same or an equivalent type recommended by the manufacturer. Dispose of used batteries according to the manufacturer's instructions.
- **CD-ROM Laser: CAUTION** - this server may have come equipped with a CD-ROM drive. To prevent direct exposure to the laser beam and hazardous radiation exposure, do not open the enclosure or use the unit in any unconventional way.
- **Mainboard replaceable soldered-in fuses: Self-resetting PTC (Positive Temperature Coefficient) fuses** on the mainboard must be replaced by trained service technicians only. The new fuse must be the same or equivalent as the one replaced. Contact technical support for details and support.

4-2 General Safety Precautions



Follow these rules to ensure general safety:

- Keep the area around the 1011S-MR2 clean and free of clutter.
- The 1011S-MR2 weighs approximately 17 lbs (7.7 kg) when fully loaded. When lifting the system, two people at either end should lift slowly with their feet spread out to distribute the weight. Always keep your back straight and lift with your legs.
- Place the chassis top cover and any system components that have been removed away from the system or on a table so that they won't accidentally be stepped on.
- While working on the system, do not wear loose clothing such as neckties and unbuttoned shirt sleeves, which can come into contact with electrical circuits or be pulled into a cooling fan.
- Remove any jewelry or metal objects from your body, which are excellent metal conductors that can create short circuits and harm you if they come into contact with printed circuit boards or areas where power is present.

- After accessing the inside of the system, close the system back up and secure it to the rack unit with the retention screws after ensuring that all connections have been made.

4-3 ESD Precautions



Electrostatic discharge (ESD) is generated by two objects with different electrical charges coming into contact with each other. An electrical discharge is created to neutralize this difference, which can damage electronic components and printed circuit boards. The following measures are generally sufficient to neutralize this difference before contact is made to protect your equipment from ESD:

- Use a grounded wrist strap designed to prevent static discharge.
- Keep all components and printed circuit boards (PCBs) in their antistatic bags until ready for use.
- Touch a grounded metal object before removing the board from the antistatic bag.
- Do not let components or PCBs come into contact with your clothing, which may retain a charge even if you are wearing a wrist strap.
- Handle a board by its edges only; do not touch its components, peripheral chips, memory modules or contacts.
- When handling chips or modules, avoid touching their pins.
- Put the motherboard and peripherals back into their antistatic bags when not in use.
- For grounding purposes, make sure your computer chassis provides excellent conductivity between the power supply, the case, the mounting fasteners and the motherboard.

4-4 Operating Precautions



Care must be taken to assure that the chassis cover is in place when the 1011S-MR2 is operating to assure proper cooling. Out of warranty damage to the 1011S-MR2 system can occur if this practice is not strictly followed.

Figure 4-1. Installing the Onboard Battery

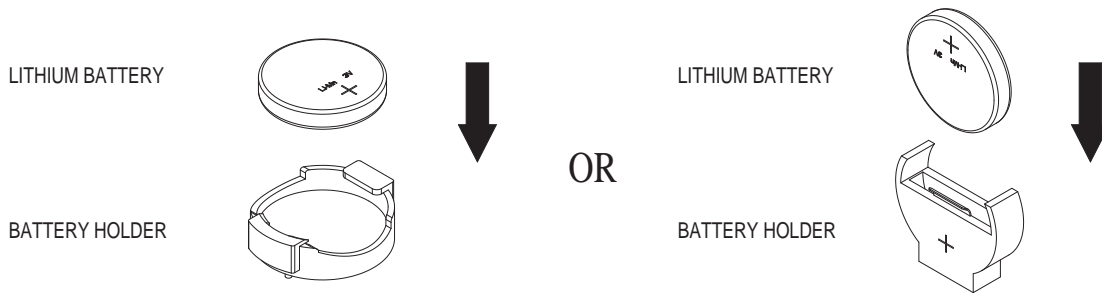

Chapter 5

Advanced Motherboard Setup

This chapter covers the steps required to install processors and heatsinks to the H8SSL-i2 motherboard, connect the data and power cables and install add-on cards. All motherboard jumpers and connections are described and a layout and quick reference chart are included in this chapter. Remember to close the chassis completely when you have finished working on the motherboard to protect and cool the system sufficiently.

5-1 Handling the Motherboard

Static electrical discharge can damage electronic components. To prevent damage to printed circuit boards, it is important to handle them very carefully (see Chapter 4). Also note that the size and weight of the motherboard can cause it to bend if handled improperly, which may result in damage. To prevent the motherboard from bending, keep one hand under the center of the board to support it when handling. The following measures are generally sufficient to protect your equipment from static discharge.

Precautions

- Use a grounded wrist strap designed to prevent static discharge.
- Touch a grounded metal object before removing any board from its antistatic bag.
- Handle a board by its edges only; do not touch its components, peripheral chips, memory modules or gold contacts.
- When handling chips or modules, avoid touching their pins.
- Put the motherboard, add-on cards and peripherals back into their antistatic bags when not in use.

Unpacking

The motherboard is shipped in antistatic packaging to avoid static damage. When unpacking the board, make sure the person handling it is static protected.

5-2 Mounting the Motherboard into a Chassis

All serverboards and motherboards have standard mounting holes to fit different types of chassis. Make sure that the locations of all the mounting holes for both the motherboard and the chassis match. Although a chassis may have both plastic and metal mounting fasteners, metal ones are highly recommended because they ground the motherboard to the chassis. Make sure that the metal standoffs click in or are screwed in tightly.

1. Check the compatibility of the motherboard ports and the I/O shield

The H8SSL-i2 motherboard requires a chassis that can support extended ATX boards of 8" x 12" in size, such as the SC512F-260. Make sure that the I/O ports on the motherboard align with their respective holes in the I/O shield at the rear of the chassis.

2. Mounting the motherboard onto the mainboard tray in the chassis

Carefully mount the motherboard onto the mainboard tray by aligning the motherboard mounting holes with the raised metal standoffs in the tray. Insert screws into all the mounting holes in the motherboard that line up with the standoffs. Then use a screwdriver to secure the motherboard to the mainboard tray - tighten until just snug (if too tight you might strip the threads). Metal screws provide an electrical contact to the motherboard ground to provide a continuous ground for the system.

5-3 Processor and Heatsink Installation



Exercise extreme caution when handling and installing the processor. Always connect the power cord last and always remove it before adding, removing or changing any hardware components.

Installing the Processor

1. Lift the lever on the CPU socket until it points straight up.



2. Use your thumb and your index finger to hold the CPU. Locate pin 1 on the CPU socket and pin 1 on the CPU. Both are marked with a triangle.

Triangles



3. Align pin 1 of the CPU with pin 1 of the socket. Once aligned, carefully place the CPU into the socket. *Do not drop the CPU on the socket, move the CPU horizontally or vertically or rub the CPU against the socket or against any pins of the socket, which may damage the CPU and/or the socket.*



4. With the CPU inserted into the socket, inspect the four corners of the CPU to make sure that it is properly installed and flush with the socket.



5. Gently press the CPU socket lever down until it locks in the plastic tab.



Installing the Heatsink

A heatsink should be installed to the processor. You will have to remove the air shroud to install. See Figure 5-1.

You may be using a Supermicro heatsink (part number SNK-P0026) or one from a third party. To install the heatsink, please follow the installation instructions included with your heatsink package.

Figure 5-1. Installing the Heatsink

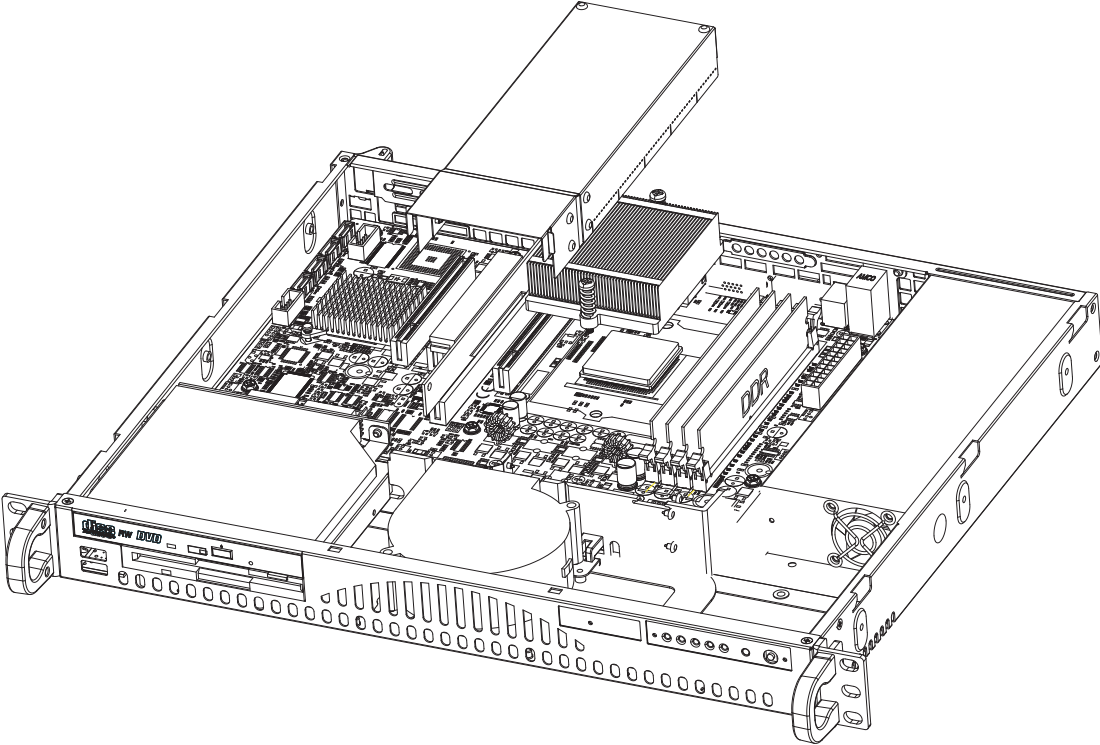

5-4 Connecting Cables

Now that the processors are installed, the next step is to connect the cables to the motherboard. These include the data (ribbon) cables for the peripherals and control panel and the power cables.

Connecting Data Cables

The ribbon cables used to transfer data from the peripheral devices have been carefully routed in preconfigured systems to prevent them from blocking the flow of cooling air that moves through the system from front to back. If you need to disconnect any of these cables, you should take care to reroute them as they were originally after reconnecting them (make sure the red wires connect to the pin 1 locations). If you are configuring the system, keep the airflow in mind when routing the cables. The following data cables (with their motherboard connector locations noted) should be connected. See the motherboard layout diagram in this chapter for connector locations.

- CD-ROM cable (IDE#1)
- SATA cable (SATA0)
- Control Panel cable (JF1, see next page)
- USB cable (USB2/3)

Connecting Power Cables

The H8SSL-i2 has a 24-pin primary power supply connector "J1B4" for connection to the ATX power supply. Connect the appropriate connector from the power supply to the "ATX Power" connector to supply power to the motherboard. See the Connector Definitions section in this chapter for power connector pin definitions.

In addition, your power supply must be connected to the 4-pin Secondary ATX Power connection at J6.

Connecting the Control Panel

JF1 contains header pins for various front control panel connectors. See Figure 5-2 for the pin locations of the various front control panel buttons and LED indicators and refer to section 5-9 for details. Note that even and odd numbered pins are on opposite sides of each header.

All JF1 wires have been bundled into single keyed ribbon cable to simplify their connection. The red wire in the ribbon cable plugs into pin 1 of JF1. Connect the other end of the cable to the Control Panel printed circuit board, located just behind the system status LEDs in the chassis.

See the Connector Definitions section in this chapter for details and pin descriptions of JF1.

Figure 5-2. Front Control Panel Header Pins (JF1)

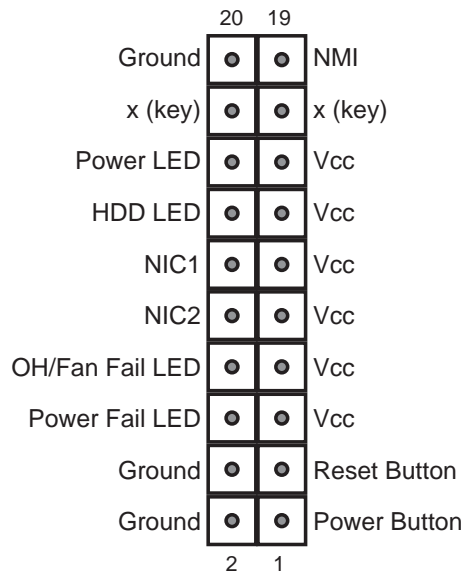

5-5 I/O Ports

The I/O ports are color coded in conformance with the PC 99 specification. See Figure 5-3 below for the colors and locations of the various I/O ports.

Figure 5-3. Rear Panel I/O Ports

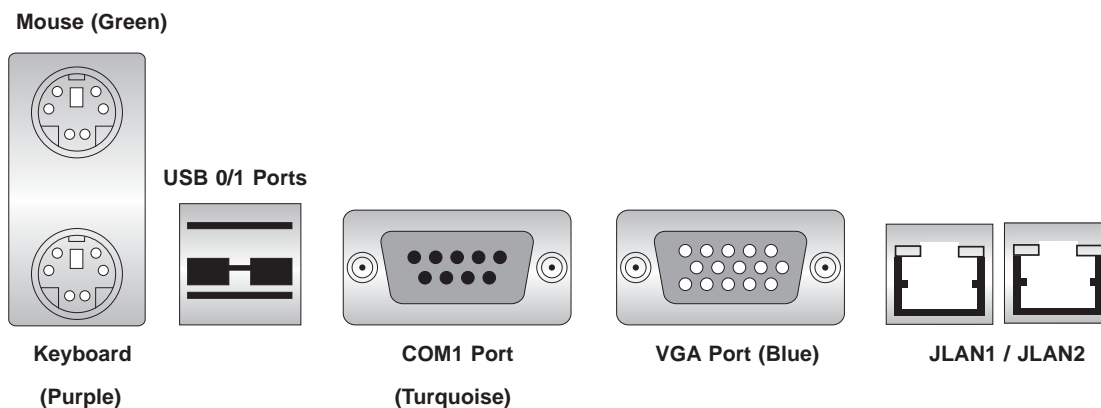

5-6 Installing Memory

CAUTION

Exercise extreme care when installing or removing memory modules to prevent any possible damage.

1. Insert each memory module vertically into its slot, beginning with slot 1A, then 2A, then 1B then 2B. Pay attention to the notch along the bottom of the module to prevent inserting the module incorrectly (see Figure 2-2). See support information below. Installing DIMMs in pairs will result in interleaved (dual-channel) memory.
2. Gently press down on the memory module until it snaps into place.

Note: It is highly recommended that you remove the power cord from the system before installing or changing any memory modules.

Support

The H8SSL-i2 supports single or dual-channel, unbuffered ECC/non-ECC DDR2-800/667/533 SDRAM.

Both interleaved and non-interleaved memory are supported, so you may populate any number of DIMM slots (see note on previous page).

Populating two adjacent slots at a time with memory modules of the same size and type will result in interleaved (128-bit) memory, which is faster than non-interleaved (64-bit) memory.

Maximum memory: 8 GB of unbuffered ECC/non-ECC DDR2-800/667/533 SDRAM.

Figure 5-4. Side and Top Views of DIMM Installation

To Install:

Insert module vertically and press down until it snaps into place. The release tabs should close - if they do not you should close them yourself.

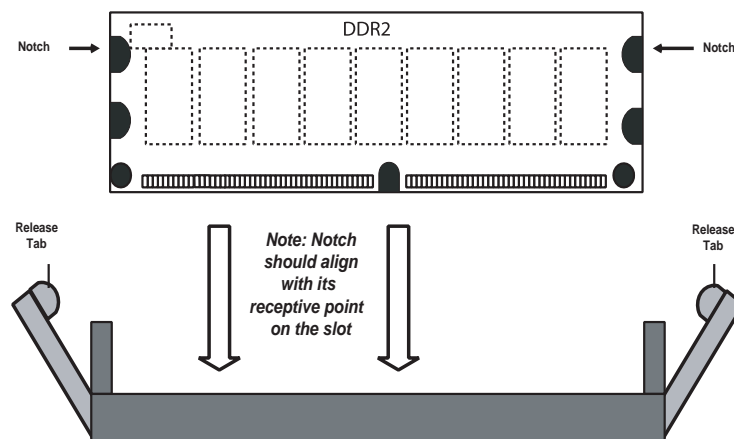

Note the notch in the slot and on the bottom of the DIMM. This prevents the DIMM from being installed incorrectly.

To Remove:

Use your thumbs to gently push each release tab outward to release the DIMM from the slot.

Top View of DDR2 Slot

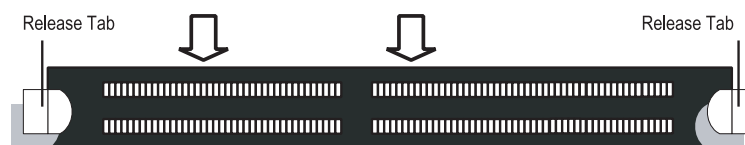

5-7 Adding PCI Cards

1. PCI slots:

The H8SSL-i2 has three PCI expansion slots. One of these slots (the 133 MHz PCI-X slot #6) may be populated with the use of the CSE-RR1U-X riser card, which is included with the system. You may install either a 133 or a 100 MHz PCI-X card into the riser card.

2. PCI card installation:

Before installing a PCI add-on card, make sure it is supported by the riser card (see step 1, above). Begin by removing the screw from the PCI shield that corresponds to slot #6. Insert the PCI card into the riser card, pushing down with your thumbs evenly on both sides of the card. Finish by securing the card to the chassis with the same screw you removed from the PCI shield.

Note: the PCI slot shield helps promote proper airflow in the chassis and shield the inside of the system from EMI (electromagnetic interference). For these reasons, make sure there is a shield covering the slot if unused.

5-8 Motherboard Details

**Figure 5-5. H8SSL-i2 Motherboard Layout
(not drawn to scale)**

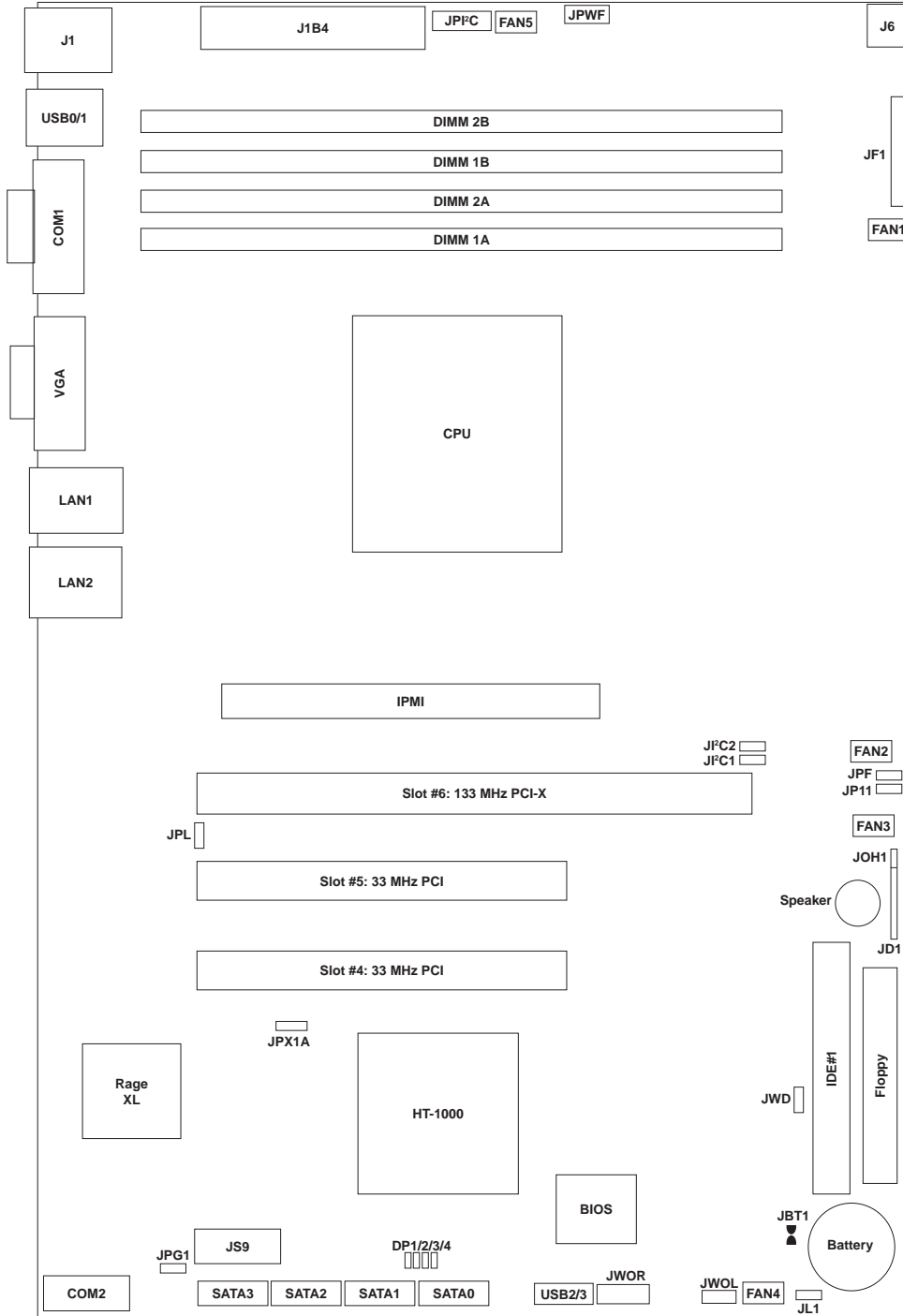

Notes:

Jumpers not indicated are for test purposes only.

H8SSL-i2 Quick Reference

Jumpers	Description	Default Setting
JBT1	CMOS Clear	See Section 5-10
JD1	Onboard Speaker En/Disable	Pins 6-7 (Enabled)
JPF	Power Force On	Open (Normal)
JPG1	VGA Enable/Disable	Pins 1-2 (Enabled)
JPL	LAN Enable/Disable	Pins 1-2 (Enabled)
JI ² C1/JI ² C2	I ² C Enable/Disable	Pins 1-2 (Enabled)
JPX1A	PCI-X Slot #6 Freq.	Open (Auto)
JWD	Watch Dog	Pins 1-2 (Reset)

Connectors	Description
IPMI	IPMI 2.0 Slot
COM1/COM2	COM1 Serial Port/Header
FAN1 - 5	Fan Headers
Floppy	Floppy Disk Drive Connector
IDE#1	IDE Connector
J1B4	Primary 24-pin ATX Power Connector
J6	Secondary 4-pin Power Connector
JD1	Power LED/Speaker Header
JF1	Front Panel Connector
JL1	Chassis Intrusion Header
JOH1	Overheat Warning Header
JP11	Power Supply Fail Alarm Reset Header
JPI ² C	Power I ² C Header
JPWF	Power Supply Fail Signal Header
JS9	Serial ATA LED Activity Header
JWOL	Wake-On-LAN Header
JWOR	Wake-On-Ring Header
LAN1/2	Gigabit Ethernet (RJ45) Ports
SATA0/1/2/3	Serial ATA Connectors
USB0/1	USB (Universal Serial Bus) Ports 0/1
USB2/3	USB2/3 Headers
VGA	Video (Monitor) Port

Onboard LEDs	Description
DP1 - DP4	Serial ATA Activity LEDs
DP6	Onboard Power LED (+3.3V)

5-9 Connector Definitions

Primary ATX Power Connector

The primary power connector on the H8SSL-i2 meets the SSI (Superset ATX) 24-pin specification. Refer to the table on the right for the pin definitions of the main ATX power connector.

Note: You must also connect the PW2 power connector to your power supply (see below).

ATX Power 24-pin Connector Pin Definitions (J1B4)			
Pin#	Definition	Pin #	Definition
13	+3.3V	1	+3.3V
14	-12V	2	+3.3V
15	COM	3	COM
16	PS_ON	4	+5V
17	COM	5	COM
18	COM	6	+5V
19	COM	7	COM
20	Res (NC)	8	PWR_OK
21	+5V	9	5VSB
22	+5V	10	+12V
23	+5V	11	+12V
24	COM	12	+3.3V

Required Connection

Secondary Power Connector

In addition to the primary ATX power connector (above), the 4-pin power connector at J6 must also be connected to your power supply. See the table on the right for pin definitions.

Secondary Power Connector Pin Definitions (J6)	
Pins	Definition
1 & 2	Ground
3 & 4	+12V

Required Connection

NMI Button

The non-maskable interrupt button header is located on pins 19 and 20 of JF1. Refer to the table on the right for pin definitions.

NMI Button Pin Definitions (JF1)	
Pin#	Definition
19	Control
20	Ground

Power LED

The Power LED connection is located on pins 15 and 16 of JF1. Refer to the table on the right for pin definitions.

Power LED Pin Definitions (JF1)	
Pin#	Definition
15	Vcc
16	Control

HDD LED

The HDD (IDE Hard Disk Drive) LED connection is located on pins 13 and 14 of JF1. Attach the IDE hard drive LED cable to display disk activity. Refer to the table on the right for pin definitions.

HDD LED Pin Definitions (JF1)	
Pin#	Definition
13	Vcc
14	HD Active

NIC1 LED

The NIC1 (Network Interface Controller) LED connection is located on pins 11 and 12 of JF1. Attach the NIC1 LED cable to display network activity. Refer to the table on the right for pin definitions.

NIC1 LED Pin Definitions (JF1)	
Pin#	Definition
11	Vcc
12	NIC1 Active

NIC2 LED

The NIC2 (Network Interface Controller) LED connection is located on pins 9 and 10 of JF1. Attach the NIC2 LED cable to display network activity. Refer to the table on the right for pin definitions.

NIC2 LED Pin Definitions (JF1)	
Pin#	Definition
9	Vcc
10	NIC2 Active

Overheat/Fan Fail LED

Connect an LED to the OH connection on pins 7 and 8 of JF1 to provide advanced warning of chassis overheating. Refer to the table on the right for pin definitions.

OH/Fan Fail LED Pin Definitions (JF1)	
Pin#	Definition
7	Vcc
8	Control

Power Fail LED

The Power Fail LED connection is located on pins 5 and 6 of JF1. See the table on the right for pin definitions.

Note: This feature is only available when using redundant power supplies.

Power Fail LED Pin Definitions (JF1)	
Pin#	Definition
5	Vcc
6	Control

Reset Button

The Reset Button connection is located on pins 3 and 4 of JF1. Attach it to the hardware reset switch on the computer case. Refer to the table on the right for pin definitions.

Reset Button Pin Definitions (JF1)	
Pin#	Definition
3	Reset
4	Ground

Power Button

The Power Button connection is located on pins 1 and 2 of JF1. Momentarily contacting both pins will power on/off the system. This button can also be configured to function as a suspend button (see the Power Button Mode setting in BIOS). To turn off the power when set to suspend mode, depress the button for at least 4 seconds. Refer to the table on the right for pin definitions.

Power Button Pin Definitions (JF1)	
Pin#	Definition
1	PW_ON
2	Ground

USB0/1 (Universal Serial Bus Ports)

Two Universal Serial Bus ports (USB2.0) are located beside the keyboard/mouse ports on the I/O backpanel. See the table on the right for pin definitions.

Universal Serial Bus Ports Pin Definitions (USB0/1)			
USB0		USB1	
Pin #	Definition	Pin #	Definition
1	+5V	1	+5V
2	PO-	2	PO-
3	PO+	3	PO+
4	Ground	4	Ground

Serial ATA Activity LEDs

Connect an LED to the JS9 header to provide indication of Serial ATA drive activity. See the table on the right for pin definitions.

Serial ATA Activity LEDs Pin Definitions (JS9)			
Pin #	Definition	Pin #	Definition
1	SATA0 LED	6	NC
2	SATA1 LED	7	NC
3	SATA2 LED	8	NC
4	SATA3 LED	9	NC
5	Ground	10	Key

Note: NC indicates no connection.

USB2/3 Headers

Two additional USB2.0 headers (USB2/3) are included on the motherboard near JWOR. These may be connected to provide front side USB access. USB cables (not included) are needed for the connections. See the table on the right for pin definitions.

Extra Universal Serial Bus Headers Pin Definitions (USB2/3)			
USB2		USB3/4	
Pin #	Definition	Pin #	Definition
1	+5V	1	+5V
2	PO-	2	PO-
3	PO+	3	PO+
4	Ground	4	Ground
5	Key	5	No connection

Serial Ports

The COM1 serial port is located between the USB ports and the VGA port. COM2 is a header located on the corner of the board near the SATA3 port (see motherboard layout for location). See the table on the right for pin definitions.

Serial Port Pin Definitions (COM1/COM2)			
Pin #	Definition	Pin #	Definition
1	DCD	6	DSR
2	RXD	7	RTS
3	TXD	8	CTS
4	DTR	9	RI
5	Ground	10	NC

Note: Pin 10 is included on the header but not on the port. NC indicates no connection.

Fan Headers

The H8SSL-i2 has five 3-pin fan headers. Fan speed is controlled via Thermal Management with a BIOS setting (refer to Chapter 4). See the table on the right for pin definitions.

Fan Header Pin Definitions (FAN1-5)	
Pin#	Definition
1	Ground
2	+12V
3	Tachometer

Overheat LED (JOH1)

Connect an LED to the JOH1 header to provide warning of chassis overheating. See the table on the right for pin definitions.

Overheat LED Pin Definitions (JOH1)	
Pin#	Definition
1	+5V
2	OH Active

Power LED/Speaker

On JD1, pins 1, 2, and 3 are for the power LED and pins 4 through 7 are for the speaker. See the tables on the right for pin definitions.

Note: The speaker connector pins are for use with an external speaker. If you wish to use the onboard speaker, you should close pins 6 and 7 with a jumper.

PWR LED Connector Pin Definitions (JD1)	
Pin#	Definition
1	+Vcc
2	Control
3	Control

Speaker Connector Pin Definitions (JD1)	
Pin#	Definition
4	Red wire, Speaker data
5	No connection
6	Buzzer signal
7	Speaker data

ATX PS/2 Keyboard and PS/2 Mouse Ports

The ATX PS/2 keyboard and mouse ports are located beside the USB ports on the IO backplane. See the table on the right for pin definitions.

PS/2 Keyboard and Mouse Port Pin Definitions (J1)			
Pin #	Definition	Pin #	Definition
1	Data	4	VCC
2	NC	5	Clock
3	Ground	6	NC

Wake-On-Ring

The Wake-On-Ring header is designated JWOR. This function allows your computer to receive and "wake-up" by an incoming call to the modem when in suspend state. See the table on the right for pin definitions. You must have a Wake-On-Ring card and cable to use this feature.

Wake-On-Ring Pin Definitions (JWOR)	
Pin#	Definition
1	Ground (Black)
2	Wake-up

Wake-On-LAN

The Wake-On-LAN header is designated JWOL. See the table on the right for pin definitions. You must have a LAN card with a Wake-On-LAN connector and cable to use the Wake-On-LAN feature.

Wake-On-LAN Pin Definitions (JWOL)	
Pin#	Definition
1	+5V Standby
2	Ground
3	Wake-up

LAN1/2 (Ethernet Ports)

Two Gigabit Ethernet ports (designated LAN1 and LAN2) are located beside the VGA port. These ports accept RJ45 type cables.



Chassis Intrusion

A Chassis Intrusion header is located at JL1. Attach the appropriate cable to inform you of a chassis intrusion.

Chassis Intrusion Pin Definitions (JL1)	
Pin#	Definition
1	Intrusion Input
2	Ground

Power I²C Header

The JPI²C header can be used to monitor the status of the power supply. See the table on the right for pin definitions.

Power I ² C Header Pin Definitions (JPI ² C)	
Pin#	Definition
1	Clock
2	SMB Data
3	N/A
4	N/A
5	N/A

Power Supply Fail Alarm Header

Connect a cable from your power supply to JPWF to provide you with warning of a power supply failure. The warning signal is passed through the PWR_LED pin to indicate a power failure. See the table on the right for pin definitions.

Power Supply Fail Alarm Header Pin Definitions (JPWF)	
Pin#	Definition
1	P/S 1 Fail Signal
2	P/S 2 Fail Signal
3	NC
4	Reset (from MB)

Note: This feature is only available when using redundant power supplies.

Power Supply Fail Alarm Reset Header

Connect JP11 to the alarm reset button on your chassis (if available) or to a microswitch to allow you to turn off the alarm that sounds when a power supply module fails. See the table on the right for pin definitions.

Alarm Reset Header Pin Definitions (JP11)	
Pin#	Definition
1	Ground
2	Reset Signal

5-10 Jumper Settings

Explanation of Jumpers

To modify the operation of the serverboard, jumpers can be used to choose between optional settings. Jumpers create shorts between two pins to change the function of the connector. Pin 1 is identified with a square solder pad on the printed circuit board. See the diagram at right for an example of jumping pins 1 and 2. Refer to the serverboard layout page for jumper locations.

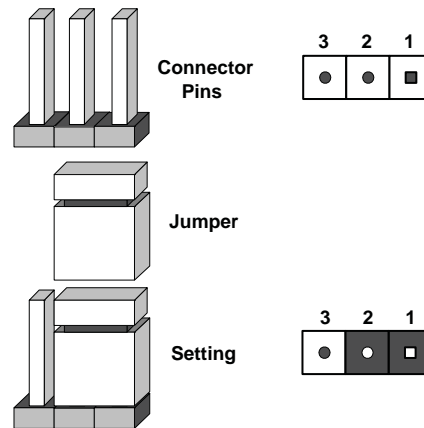

Note 1: On two-pin jumpers, "Closed" means the jumper is on and "Open" means the jumper is off the pins.

CMOS Clear

JBT1 is used to clear CMOS and will also clear any passwords. Instead of pins, this jumper consists of contact pads to prevent accidentally clearing the contents of CMOS.

To clear CMOS,

- 1) First power down the system and unplug the power cord(s).
- 2) With the power disconnected, short the CMOS pads with a metal object such as a small screwdriver for at least four seconds.
- 3) Remove the screwdriver (or shorting device).
- 4) Reconnect the power cord(s) and power on the system.

Notes:

Do not use the PW ON connector to clear CMOS.

The onboard battery does not need to be removed when clearing CMOS, however you must short JBT1 for at least four seconds.



JBT1 contact pads

Onboard Speaker Enable/ Disable

The JD1 header allows you to use either an external speaker or the internal (onboard) speaker. To use the internal (onboard) speaker, close pins 6 and 7 with a jumper. To use an external speaker, connect the speaker wires to pins 4 through 7 of JD1. See the table on the right for settings and the table associated with the Power LED/Speaker connection (previous section) for pin definitions.

Onboard Speaker Enable/Disable Pin Definitions (JD1)	
Pins	Definition
6-7	Jump for onboard speaker
4-7	Attach external speaker wires

PCI-X Slot Speed

Jumper JPX1A can be used to change the speed of PCI-X slot #6. See the table on the right for jumper settings.

PCI-X Slot Speed Jumper Settings (JPX1A)	
Jumper Setting	Definition
Open	Auto
Pins 1-2	PCI-X 66 MHz
Pins 2-3	PCI 66 MHz

VGA Enable/Disable

JPG1 allows you to enable or disable the VGA port. The default position is on pins 1 and 2 to enable VGA. See the table on the right for jumper settings.

VGA Enable/Disable Jumper Settings (JPG1)	
Jumper Setting	Definition
Pins 1-2	Enabled
Pins 2-3	Disabled

LAN Enable/Disable

Change the setting of jumper JPL to enable or disable the LAN1 and LAN2 Gb Ethernet ports. See the table on the right for jumper settings. The default setting is enabled.

JLAN1/2 Enable/Disable Jumper Settings (JPL)	
Jumper Setting	Definition
Pins 1-2	Enabled
Pins 2-3	Disabled

Watch Dog Enable/Disable

JWD controls the Watch Dog function. Watch Dog is a system monitor that can reboot the system when a software application hangs. Pins 1-2 will cause WD to reset the system if an application has frozen. Pins 2-3 will generate a non-maskable interrupt signal for the application that is frozen. See the table on the right for jumper settings. Watch Dog must also be enabled in BIOS.

Watch Dog Jumper Settings (JWD)	
Jumper Setting	Definition
Pins 1-2	Reset
Pins 2-3	NMI
Open	Disabled

Note: When enabled, the user needs to write their own application software in order to disable the Watch Dog Timer.

Power Force On

JPF allows you to enable or disable the Power Force On function. If enabled, system power will always stay on. If disabled (the default setting), the user needs to depress the power button to power up the system.

Power Force On Jumper Settings (JPF)	
Jumper Setting	Definition
Closed	Force On
Open	Disabled

I²C Enable/Disable

Jumpers JI²C1 and JI²C2 allow you to enable or disable I²C. Both jumpers must be set to the same setting, either both open or both closed. See the table on the right for jumper settings.

I ² C Enable/Disable Jumper Settings (JI ² C1/JI ² C2)	
Jumper Setting	Definition
Pins 1-2	Enabled
Pins 2-3	Disabled

5-11 Onboard Indicators

LAN1/LAN2 LEDs

The Ethernet ports (located beside the VGA port) have two LEDs. On each Gb LAN port, one LED blinks to indicate activity while the other LED may be green, amber or off to indicate the speed of the connection. See the table on the right for the functions associated with the connection speed LED.

LAN LED (Connection Speed Indicator)	
LED Color	Definition
Off	10 MHz
Green	100 MHz
Amber	1 GHz

SATA Activity LEDs

When illuminated, the DP1, DP2, DP3 and DP4 LEDs indicate activity on SATA channels SATA3, SATA2, SATA1 and SATA0, respectively

SATA Activity LEDs (DP1-DP3)	
State	System Status
On	SATA channel active
Off	SATA channel inactive

Onboard Power LED

DP6 is an onboard power LED. When this LED is lit, it means power is present on the serverboard. In suspend mode this LED will blink on and off. Be sure to turn off the system and unplug the power cord(s) before removing or installing components.

5-12 Floppy, IDE and SATA Drive Connections

Use the following information to connect the floppy and hard disk drive cables.

- The floppy disk drive cable has seven twisted wires.
- A red mark on a wire typically designates the location of pin 1.
- A single floppy disk drive ribbon cable has 34 wires and two connectors to provide for two floppy disk drives. The connector with twisted wires always connects to drive A, and the connector that does not have twisted wires always connects to drive B.

Floppy Connector

The floppy connector is located beside the IDE#1 connector. See the table on the right for pin definitions.

Floppy Drive Connector Pin Definitions (Floppy)			
Pin#	Definition	Pin #	Definition
1	GND	2	FDHDIN
3	GND	4	Reserved
5	Key	6	FDEDIN
7	GND	8	Index-
9	GND	10	Motor Enable
11	GND	12	Drive Select B-
13	GND	14	Drive Select A-
15	GND	16	Motor Enable
17	GND	18	DIR-
19	GND	20	STEP-
21	GND	22	Write Data-
23	GND	24	Write Gate-
25	GND	26	Track 00-
27	GND	28	Write Protect-
29	GND	30	Read Data-
31	GND	32	Side 1 Select-
33	GND	34	Diskette

IDE Connector

There are no jumpers to configure the onboard IDE#1 connector. See the table on the right for pin definitions.

IDE Drive Connector Pin Definitions (IDE#1)			
Pin#	Definition	Pin #	Definition
1	Reset IDE	2	Ground
3	Host Data 7	4	Host Data 8
5	Host Data 6	6	Host Data 9
7	Host Data 5	8	Host Data 10
9	Host Data 4	10	Host Data 11
11	Host Data 3	12	Host Data 12
13	Host Data 2	14	Host Data 13
15	Host Data 1	16	Host Data 14
17	Host Data 0	18	Host Data 15
19	Ground	20	Key
21	DRQ3	22	Ground
23	I/O Write	24	Ground
25	I/O Read	26	Ground
27	IOCHRDY	28	BALE
29	DACK3	30	Ground
31	IRQ14	32	IOCS16
33	Addr1	34	Ground
35	Addr0	36	Addr2
37	Chip Select 0	38	Chip Select 1
39	Activity	40	Ground

SATA Ports

There are no jumpers to configure the SATA ports, which are designated SATA0, SATA1, SATA2 and SATA3. See the table on the right for pin definitions.

SATA Ports Pin Definitions (SATA0-SATA3)	
Pin #	Definition
1	Ground
2	TXP
3	TXN
4	Ground
5	RXN
6	RXP
7	Ground

5-13 Enabling SATA RAID

Now that the hardware is set up, you must now install the operating system and the SATA RAID drivers, if you wish to use RAID with your SATA drives. The installation procedure differs depending on whether you wish to have the operating system installed on a RAID array or on a separate non-RAID, IDE drive. See the instructions below for details.

Serial ATA (SATA)

Serial ATA (SATA) is a physical storage interface that employs a single cable with a minimum of four wires to create a point-to-point connection between devices. This connection is a serial link that supports a SATA transfer rate from 150 MBps. The serial cables used in SATA are thinner than the traditional cables used in Parallel ATA (PATA) and can extend up to one meter in length, compared to only 40 cm for PATA cables. Overall, SATA provides better functionality than PATA.

Installing the OS/SATA Driver

Before installing the OS (operating system) and SATA RAID driver, you must decide if you wish to have the operating system installed as part of a bootable RAID array or installed to a separate non-RAID, IDE hard drive. If on a separate IDE drive, skip ahead to section entitled Enabling SATA RAID in the BIOS. If you wish to have the OS on a SATA RAID array, you must first complete the step below.

Building a Driver Diskette

You must first build a driver diskette from the Supermicro CD-ROM that was included with the system. (You will have to create this disk on a computer that is already running and with the OS installed. Note that this driver only works with Windows 2003. After building the driver diskette, insert the driver floppy into the floppy drive in your system (must be an IDE floppy and not a USB floppy) and insert the OS Installation CD into your CD-ROM or DVD drive. Boot up the system and press the <F6> key. You will then be able to create a partition on the disk where the OS will be installed. After the OS is installed the system will automatically reboot. You can now skip ahead to section entitled Enabling SATA RAID in the BIOS.

Installing the Operating System

If the operating system has not yet been installed, you should install it now. With the Windows OS installation CD in the CD-ROM drive, restart the system. When you see the prompt, hit the <F6> key to enter Windows setup. Follow the prompts as they appear to install the OS. Once installed, proceed to the next step to enable RAID and set up your RAID drives.

Enabling SATA RAID in the BIOS

Before setting up your RAID drives, you must change some settings in BIOS. Boot up the system and hit the key to enter the BIOS Setup Utility. After the Setup Utility loads,

1. Use the arrow keys to move to the Advanced menu. Scroll down with the arrow keys to "SATA Configuration" and press <Enter>. When the submenu opens, use the arrow keys to select "HT-1000 SATA" and enable this setting (if not already enabled.) Then in the same submenu, scroll down to the "SATA Mode" setting and select the "RAID" option.
2. Hit the <Esc> key until you return to the main Setup menu, then scroll over to the Exit menu. Select "Save Changes and Exit" and hit <Enter>, then hit <Enter> again to verify.
3. After exiting the BIOS Setup Utility, the system will reboot. When the system is rebooting, press the <Ctrl> and <R> keys simultaneously. This will activate the HT-1000 RAID Utility program.

Using the HT-1000 RAID Utility

The HT-1000 RAID Utility program is where you can define the drives you want to include in the RAID array and the mode and type of RAID. The utility is comprised of three main windows, as shown in Figure 5-6. The "Disks" window on the right will list all available drives. The procedure below outlines the steps necessary to create a RAID array as seen in the "Main Menu" window of the RAID utility. In each step, note the "Available Keys" window in the bottom right of the screen. These are the keys used to perform the various functions in each step.

Initialize Disks(s)

The first step is to initialize drives as part of the RAID array. Using the keys noted in the "Available Keys" window, navigate through the available disks shown in the "Disks" window and select those you wish to add to your array. When selected, a disk will be highlighted in green.

Create Array

After selecting the disks for your array, you are ready to select the type of array to create. Array types may be limited by the number of disks selected and the RAID levels supported by your system. After selecting the array type you will be prompted to choose the caching mode (read/write, read only or none). After this selection you have the array set up. Press the <C> key to confirm the configuration of your array and reboot the system.

Note: a RAID controller program (RAIDCore) may be downloaded from the Broadcom web site. On their home page (www.broadcom.com) click on Downloads & Support > RAID Driver Downloads then under Operating Systems click on Windows.

Figure 5-6. HT1000 RAID Utility Screen

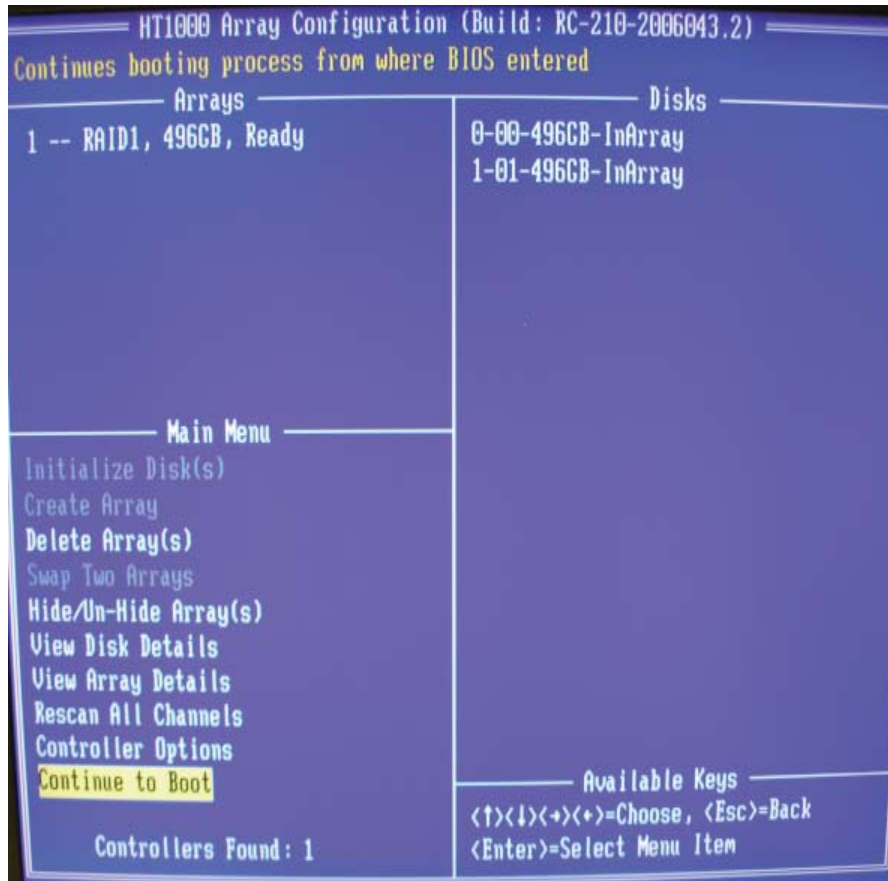

On the next page you will see the Windows Media Kit. Download this and install to your system for RAID management.

Installing Other Software Drivers

The Supermicro CD that came packaged with your motherboard has additional drivers. After inserting this CD into your CD-ROM drive, the display shown in Figure 5-7 should appear. (If this display does not appear, click on the My Computer icon and then on the icon representing your CD-ROM drive. Finally, double click on the S "Setup" icon.)

Click the icons showing a hand writing on paper to view the readme files for each item. Click the tabs to the right of these in order from top to bottom to install each item one at a time. After installing each item, you must reboot the system before moving on to the next item on the list. You should install everything here except for the SUPER Doctor utility, which is optional. The bottom icon with a CD on it allows you to view the entire contents of the CD.

Figure 5-7. Driver/Tool Installation Display Screen

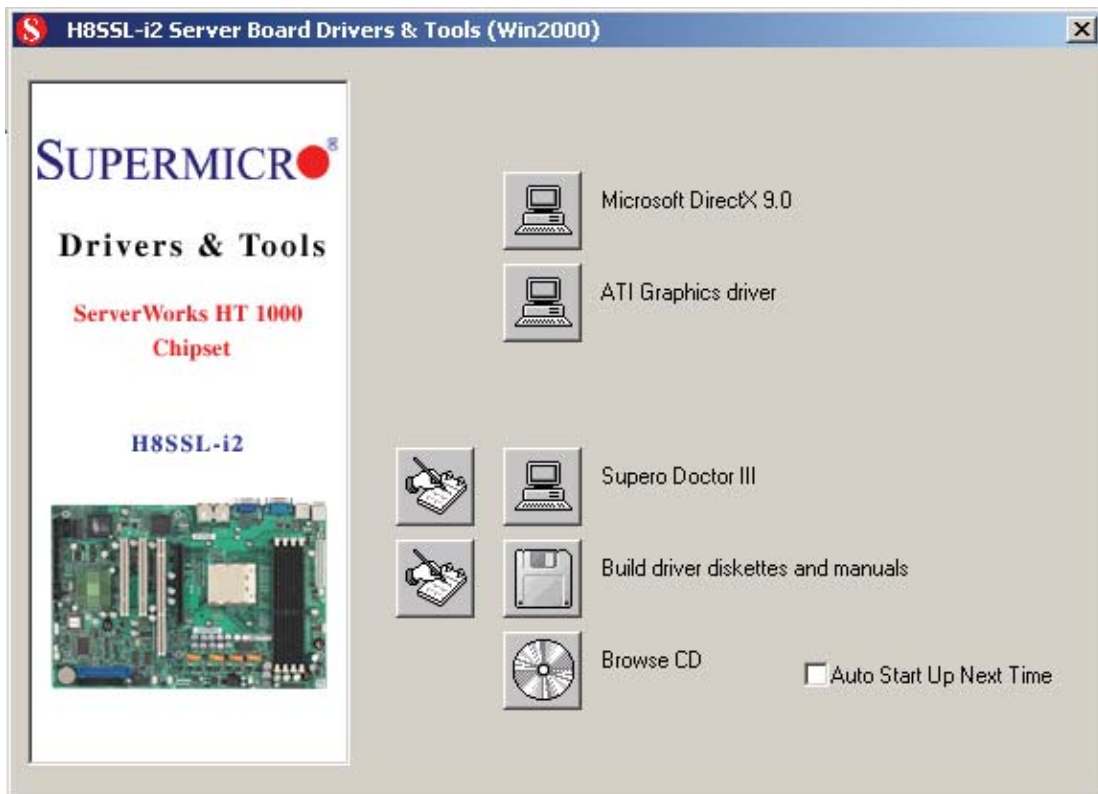

Notes

Chapter 6

Advanced Chassis Setup

This chapter covers the steps required to install components and perform maintenance on the SC512F-260 chassis. For component installation, follow the steps in the order given to eliminate the most common problems encountered. If some steps are unnecessary, skip ahead to the step that follows.

Tools Required

The only tool you will need to install components and perform maintenance is a Philips screwdriver.

6-1 Static-Sensitive Devices

Electrostatic Discharge (ESD) can damage electronic components. To prevent damage to any printed circuit boards (PCBs), it is important to handle them very carefully. The following measures are generally sufficient to protect your equipment from ESD discharge.

Precautions

- Use a grounded wrist strap designed to prevent static discharge.
- Touch a grounded metal object before removing any board from its antistatic bag.
- Handle a board by its edges only; do not touch its components, peripheral chips, memory modules or gold contacts.
- When handling chips or modules, avoid touching their pins.
- Put the motherboard, add-on cards and peripherals back into their antistatic bags when not in use.
- For grounding purposes, make sure your computer chassis provides excellent conductivity between the power supply, the case, the mounting fasteners and the motherboard.

Unpacking

The motherboard is shipped in antistatic packaging to avoid static damage. When unpacking the board, make sure the person handling it is static protected.

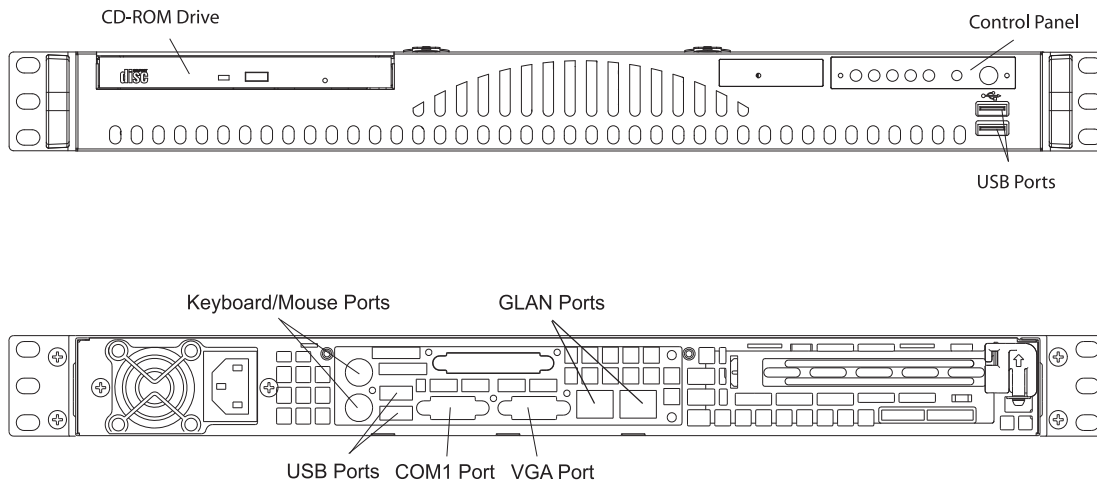
Figure 6-1. Chassis Views

6-2 Control Panel

The control panel (located on the front of the chassis) must be connected to the JF1 connector on the motherboard to provide you with system control buttons and status indicators. These wires have been bundled together in a ribbon cable to simplify the connection. Connect the cable from JF1 on the motherboard to JP4 on the Control Panel PCB (printed circuit board). Make sure the red wire plugs into pin 1 on both JF1 and JP4. Pull all excess cabling out of the airflow path. The LEDs inform you of system status. See Chapter 3 for details on the LEDs and the control panel buttons. Details on JF1 can be found in Chapter 5.

6-3 System Fans

The server uses 4-cm counter-rotating fans to provide cooling. The 1011S-MR2 has two sets of these fans. Each fan unit is actually made up of two fans joined back-to-back, which rotate in opposite directions. This counter-rotating action generates exceptional airflow and works to dampen vibration levels. These fans can adjust their speed according to the heat level sensed in the system, which results in more efficient and quieter fan operation. Fan speed is controlled by a setting in BIOS (see Chapter 7). Each fan in a set has its own separate tachometer.

It is very important that the chassis top cover is properly installed for the airflow to circulate properly through the chassis and cool the components.

System Fan Failure

If a fan fails, the remaining fans will ramp up to full speed and the overheat/fan fail LED on the control panel will blink on and off. Replace any failed fan at your earliest convenience with the same type and model (the system can continue to run with a failed fan). Remove the top chassis cover while the system is still running to determine which of the two fan units has failed. Then power down the system before replacing a fan. Removing the power cord(s) is also recommended as a safety precaution.

Replacing System Cooling Fans

1. Removing a fan

With the system powered down, first remove the chassis cover (refer to page 6-6). Grasp the failed fan unit and lift it out of the chassis. See Figure 6-2.

2. Installing a new fan

Replace the failed fan with an identical 4-cm, 12 volt fan (available from Supermicro: p/n FAN-0087). Push the new fan into the vacant space in the housing while making sure the arrows on the top of the fan (indicating air direction) point in the same direction as the arrows on the other fans. Reposition the fan housing back over the two mounting posts in the chassis, then reconnect the fan wires to the same chassis fan headers you removed them from. Power up the system and check that the fan is working properly and that the LED on the control panel has turned off. Finish by replacing the chassis cover.

Figure 6-2. System Cooling Fans

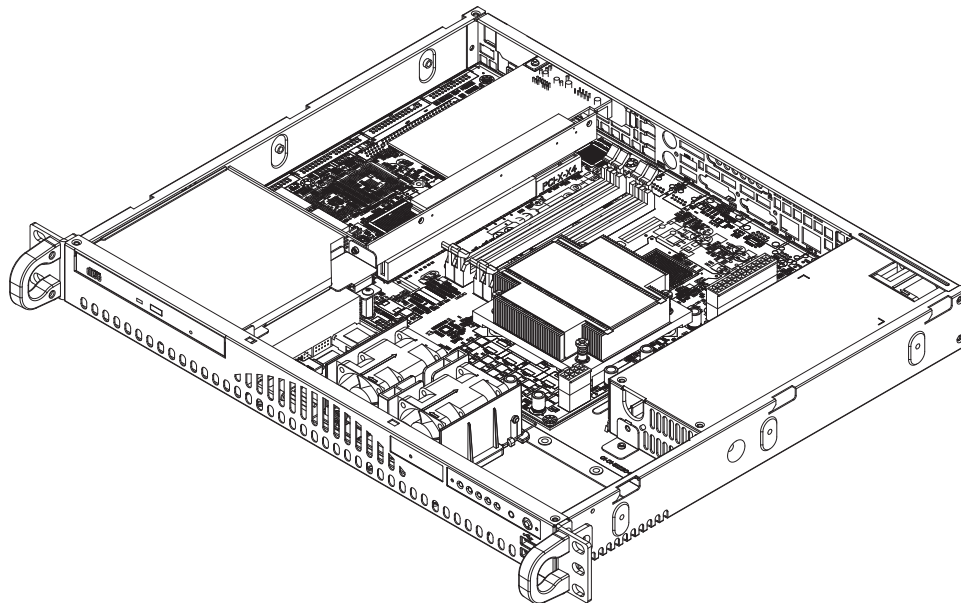

6-4 Drive Bay Installation/Removal

Accessing the Drive Bays

CD-ROM/Serial ATA Drives: For installing or removing the CD-ROM or Serial ATA drive, you will need to gain access to the inside of the server by removing the top cover of the chassis.

Note: Only a "slim" CD-ROM will fit in the 1011S-MR2.

Serial ATA Drive Installation

The SATA drive is not hot-swappable, meaning system power must be turned off before installing or removing.

To install or remove the drive, first power down the system and then remove the top cover of the chassis as described on page 6-6. Unscrew the retention screw at the top center of the drive, then push the drive tray out from the back until you can grasp and pull it out through the front of the chassis. Remove the drive from the drive tray.

To add a new SATA drive, install a drive into the tray with the printed circuit board side facing down and so that the mounting holes align with those in the tray. Secure the drive to the tray with the four screws. Replace the top cover when finished. See Figure 6-3.

CD-ROM Drive Installation

The top cover of the chassis must be opened to gain full access to the CD-ROM drive bay. The CD-ROM must have a "slim" profile to fit into the 1011S-MR2. If you cannot remove the top cover with the system remaining in the rack, follow the procedure below.

First, shutdown the system and disconnect all cables from the back of the server chassis. Make sure the system is supported from underneath then remove the front bracket screws that secure the unit to the rack. Carefully lift the server out of the rack.

Open the cover by following the procedure described on page 6-6. You must power down the system before installing or removing the CD-ROM or SATA drive. Remove the two screws that secure the CD-ROM drive to the chassis and then lift the drive out of the chassis. See Figure 6-3.

Note: A red mark on a wire typically designates the location of pin 1. The CD-ROM may only be used as a Master IDE device.

Figure 6-3. Removing the SATA/CD-ROM Drive

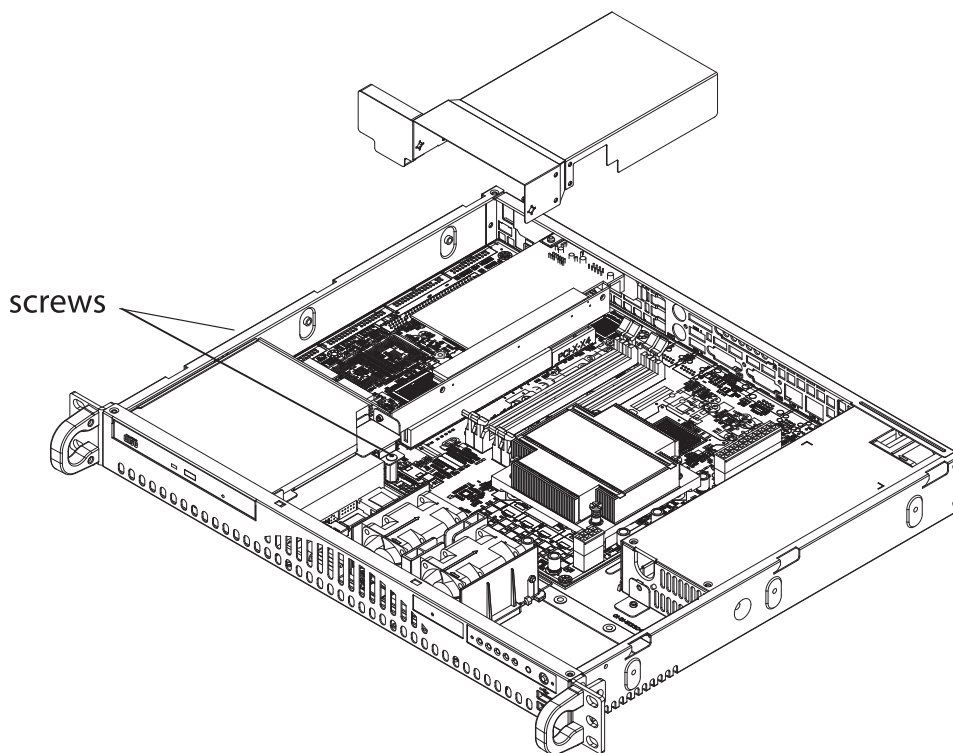

6-5 Power Supply

The SuperServer 1011S-MR2 has a single 260 watt power supply. This power supply has the capability of operating at 100 - 240 input volts. Power down the system and then unplug the AC power cord to completely remove power from the system before removing the power supply.

Power Supply Failure

If the power supply unit fails, the system will shut down and you will need to replace the power supply unit. Replacement units can be ordered directly from Supermicro (PWS-0055 - see contact information in Chapter 1).

Replacing the Power Supply

1. Accessing the inside of the system

To replace a power supply, you must first remove the top chassis cover. To do so, first release the retention screws that secure the unit to the rack. Grasp the two handles on either side and pull the unit straight out until it locks (you will hear a "click"). Next, remove the screws from the lips on either side of the cover then depress the two buttons on the cover to release it. Push the cover away from you then lift it from the chassis to gain full access to the inside of the server (see Figure 2-6).

2. Removing the power supply

First unplug the power cord from the system. To remove the failed power unit, remove the two screws on the back of the power supply and a third from the front of the power supply, which secures it to the bottom of the chassis. You can then lift the unit straight out of the chassis. (The power cord should have already been removed.)

3. Installing a new power supply

Replace the failed unit with another unit of the same wattage. It is highly recommended to replace it with the exact same power supply. Carefully insert the new unit into position in the chassis and secure it with the two screws at the rear of the unit and the third at the front. Then reconnect the power cord, replace the chassis top cover and push the unit back into the rack. Finish by turning the power switch on the power supply on, and then depress the power button on the front of the system.

Chapter 7

BIOS

7-1 Introduction

This chapter describes the AMIBIOS™ Setup utility for the H8SSL-i2. The AMI ROM BIOS is stored in a flash chip and can be easily upgraded using a floppy disk-based program.

Note: Due to periodic changes to the BIOS, some settings may have been added or deleted and might not yet be recorded in this manual. Please refer to the Manual Download area of our web site for any changes to BIOS that may not be reflected in this manual.

Starting the Setup Utility

To enter the BIOS Setup Utility, hit the <Delete> key while the system is booting-up. (In most cases, the <Delete> key is used to invoke the BIOS setup screen. There are a few cases when other keys are used, such as <F1>, <F2>, etc.) Each main BIOS menu option is described in this manual.

The Main BIOS screen has two main frames. The left frame displays all the options that can be configured. “Grayed-out” options cannot be configured. The right frame displays the key legend. Above the key legend is an area reserved for a text message. When an option is selected in the left frame, it is highlighted in white. Often a text message will accompany it. (Note that BIOS has default text messages built in. We retain the option to include, omit, or change any of these text messages.) Settings printed in **Bold** are the default values.

A " ►" indicates a submenu. Highlighting such an item and pressing the <Enter> key will open the list of settings within that submenu.

The BIOS setup utility uses a key-based navigation system called hot keys. Most of these hot keys (<F1>, <F10>, <Enter>, <ESC>, <Arrow> keys, etc.) can be used at any time during the setup navigation process.

7-2 Main Menu

When you first enter AMI BIOS Setup Utility, you will see the Main setup screen. You can always return to the Main setup screen by selecting the **Main** tab on the top of the screen.

The Main Setup screen provides you with a system overview, which includes the version, built date and ID of the AMIBIOS, the type, speed and number of the processors in the system and the amount of memory installed in the system.

System Time/System Date

You can edit this field to change the system time and date. Highlight *System Time* or *System Date* using the <Arrow> keys. Enter new values through the keyboard. Press the <Tab> key or the <Arrow> keys to move between fields. The date must be entered in DAY/MM/DD/YYYY format. The time is entered in HH:MM:SS format. Please note that time is in a 24-hour format. For example, 5:30 A.M. appears as 05:30:00 and 5:30 P.M. as 17:30:00.

7-3 Advanced Settings Menu

► Boot Features

Quick Boot

If Enabled, this option will skip certain tests during POST to reduce the time needed for the system to boot up. The options are **Enabled** and Disabled.

Quiet Boot

If **Disabled**, normal POST messages will be displayed on boot-up. If Enabled, this display the OEM logo instead of POST messages.

Add-On ROM Display Mode

This setting controls the display of add-on ROM (read-only memory) messages. Select "**Force BIOS**" to allow the computer system to force a third party BIOS to display during system boot. Select "Keep Current" to allow the computer system to display the BIOS information during system boot.

Boot up Num-Lock

Set this to "On" to allow the Number Lock setting to be modified during boot up. The options are **On** and Off.

PS/2 Mouse Support

This setting is to specify PS/2 mouse support. The options are **Auto**, Enabled and Disabled.

Wait for 'F1' If Error

Enable to activate the Wait for F1 if Error function. The options are **Enabled** and Disabled.

Hit 'DEL' Message Display

Enable to display the message telling the user to hit the DEL key to enter the setup utility. The options are **Enabled** and Disabled.

PXE Option ROM

Use this setting to either Enable or Disable the PXE ROM. The options are **Enabled** and Disabled.

Interrupt 19 Capture

Enable to allow ROMs to trap Interrupt 19. The options are **Enabled** and Disabled.

ACPI Version Features

Select which version of ACPI you wish to use. Options are **ACPI v. 1.0**, ACPI v. 2.0 and ACPI v. 3.0.

ACPI APIC Support

Select "Enabled" to allow the ACPI APIC Table Pointer to be included in the RSDT pointer list. The options are **Enabled** and Disabled.

ACPI OEMB Table

This setting when enabled will include an OEMB table pointer to pointer lists. Options are **Enabled** and Disabled.

Headless Mode

Select "Enabled" to activate the Headless Operation Mode through ACPI. The options are Enabled and **Disabled**.

Power Button Instant Off

Allows the user to change the function of the power button to "Instant Off". Options are **Enabled** and Disabled.

Restore on AC Power Loss

This setting allows you to choose how the system will react when power returns after an unexpected loss of power. The options are **Power Off**, Power On and Last State.

Watch Dog Timer

This setting is used to Enable or **Disable** the Watch Dog Timer function. It must be used in conjunction with the Watch Dog jumper (see Chapter 2 for details).

MPS Revision

This setting allows the user to select the MPS revision level to 1.1 or **1.4**.

Smbios Configuration

This setting is used to Enable or Disable the SMBIOS SMI support. The options are **Enabled** and Disabled.

► CPU Configuration

Various CPU information is displayed here in addition to the settings below.

GART Error Reporting

This setting is used for testing only.

MTRR Mapping

This determines the method used for programming CPU MTRRs when 4 GB or more memory is present. The options are **Continuous**, which makes the PCI hole non-cacheable, and Discrete, which places the PCI hole below the 4 GB boundary.

Power Now

This setting is used to Enable or **Disable** the AMD Power Now feature.

► Floppy/IDE/SATA Configuration

Floppy A

Move the cursor to these fields via up and down <arrow> keys to select the floppy type. The options are Disabled, 360 KB 5 1/4", 1.2 MB 5 1/4", 720 KB 3 1/2", **1.44 MB 3 1/2"**, and 2.88 MB 3 1/2".

Floppy B

Move the cursor to these fields via up and down <arrow> keys to select the floppy type. The options are **Disabled**, 360 KB 5 1/4", 1.2 MB 5 1/4", 720 KB 3 1/2", 1.44 MB 3 1/2", and 2.88 MB 3 1/2".

Onboard Floppy Controller

Use this setting to **Enable** or Disable the onboard floppy controller.

HT1000 S-ATA

Use this setting to **Enable** or Disable the SATA controller in the HT1000 chipset.

S-ATA Mode

Use this setting to specify the SATA mode: either **IDE** or MMIO.

Onboard PCI IDE Controller

The following options are available to set the IDE controller status: Disabled will disable the controller. **Primary** will enable the primary IDE controller. There is no Secondary option since only one IDE slot is provided on the board.

Primary IDE Master/Slave

Highlight one of the two items above and press <Enter> to access the submenu for that item.

Type

Select the type of device connected to the system. The options are Not Installed, **Auto**, CDROM and ARMD.

LBA/Large Mode

LBA (Logical Block Addressing) is a method of addressing data on a disk drive. In the LBA mode, the maximum drive capacity is 137 GB. For drive capacities of over 137 GB, your system must be equipped with 48-bit LBA mode addressing. If not, contact your manufacturer or install an ATA/133 IDE controller card that supports 48-bit LBA mode. The options are Disabled and **Auto**.

Block (Multi-Sector Transfer)

Block mode boosts IDE drive performance by increasing the amount of data transferred. Only 512 bytes of data can be transferred per interrupt if block mode is not used. Block mode allows transfers of up to 64 KB per interrupt. Select "Disabled" to allow the data to be transferred from and to the device one sector at a time. Select "Auto" to allow the data transfer from and to the device occur multiple sectors at a time if the device supports it. The options are **Auto** and Disabled.

PIO Mode

PIO (Programmable I/O) mode programs timing cycles between the IDE drive and the programmable IDE controller. As the PIO mode increases, the cycle time decreases. The options are **Auto**, 0, 1, 2, 3, and 4. Select Auto to allow AMI BIOS to auto detect the PIO mode. Use this value if the IDE disk drive support cannot be determined. Select 0 to allow AMI BIOS to use PIO mode 0. It has a data transfer rate of 3.3 MBs. Select 1 to allow AMI BIOS to use PIO mode 1. It has a data transfer rate of 5.2 MBs. Select 2 to allow AMI BIOS to use PIO mode 2. It has a data transfer rate of 8.3 MBs. Select 3 to allow AMI BIOS to use PIO mode 3. It has a data transfer rate of 11.1 MBs. Select 4 to allow AMI BIOS to use PIO mode 4. It has a data transfer rate of 16.6 MBs. This setting generally works with all hard disk drives manufactured after 1999. For other disk drives, such as IDE CD-ROM drives, check the specifications of the drive.

DMA Mode

Select the DMA mode of the drive. Options are **Auto**, SWDMA0, SWDMA1, SWDMA2, MWDMA0, MWDMA1, MWDMA2, UDMA0, UDMA1 and UDMA2.

S.M.A.R.T.

Self-Monitoring Analysis and Reporting Technology (SMART) can help predict impending drive failures. Select "Auto" to allow BIOS to auto detect hard disk drive support. Select "Disabled" to prevent AMI BIOS from using the S.M.A.R.T. Select "Enabled" to allow AMI BIOS to use the S.M.A.R.T. to support hard drive disk. The options are Disabled, Enabled, and **Auto**.

32-Bit Data Transfer

Select "Enabled" to activate the function of 32-Bit data transfer. Select "Disabled" to deactivate the function. The options are **Enabled** and Disabled.

Hard Disk Write Protect

Select Enabled to enable the function of Hard Disk Write Protect to prevent data from being written to HDD. The options are Enabled or **Disabled**.

IDE Detect Time Out (Sec)

This feature allows the user to set the time-out value for detecting ATA, ATA PI devices installed in the system. The options are 0 (sec), 5, 10, 15, 20, 25, 30 and **35**.

ATA(PI) 80Pin Cable Detection

This setting allows AMI BIOS to auto-detect the 80-Pin ATA(PI) cable. The options are **Host & Device**, Host and Device.

► PCI/PnP

Clear NVRAM

Select Yes to clear NVRAM during boot-up. The options are Yes and **No**.

Plug & Play OS

Select Yes to allow the OS to configure Plug & Play devices. (This is not required for system boot if your system has an OS that supports Plug & Play.) Select **No** to allow AMIBIOS to configure all devices in the system.

PCI Latency Timer

This option sets the latency of all PCI devices on the PCI bus. Select a value to set the PCI latency in PCI clock cycles. Options are 32, **64**, 96, 128, 160, 192, 224 and 248.

Allocate IRQ to PCI VGA

Set this value to allow or restrict the system from giving the VGA adapter card an interrupt address. The options are **Yes** and No.

Palette Snooping

Select "Enabled" to inform the PCI devices that an ISA graphics device is installed in the system in order for the graphics card to function properly. The options are Enabled and **Disabled**.

PCI IDE BusMaster

Set this value to allow or prevent the use of PCI IDE busmastering. Select "Enabled" to allow AMI BIOS to use PCI busmaster for reading and writing to IDE drives. The options are **Disabled** and Enabled.

Offboard PCI/ISA IDE Card

This option allows the user to assign a PCI slot number to an Off-board PCI/ISA IDE card in order for it to function properly. The options are **Auto**, PCI Slot1, PCI Slot2, PCI Slot3, PCI Slot4, PCI Slot5, and PCI Slot6.

IRQ3/IRQ4/IRQ5/IRQ7/IRQ9/IRQ10/IRQ11/IRQ14/IRQ15

This feature specifies the availability of an IRQ to be used by a PCI/PnP device. Select Reserved for the IRQ to be used by a Legacy ISA device. The options are **Available** and Reserved.

DMA Channel0/Channel1/Channel3/Channel5/Channel6/Channel7

Select Available to indicate that a specific DMA channel is available to be used by a PCI/PnP device. Select Reserved if the DMA channel specified is reserved for a Legacy ISA device. The options are **Available** and Reserved.

Reserved Memory Size

This feature specifies the size of memory block to be reserved for Legacy ISA devices. The options are **Disabled**, 16K, 32K and 64K.

► Super IO Configuration

Serial Port1 Address

This option specifies the base I/O port address and Interrupt Request address of serial port 1. Select "Disabled" to prevent the serial port from accessing any system resources. When this option is set to *Disabled*, the serial port physically becomes unavailable. Select "3F8/IRQ4" to allow the serial port to use 3F8 as its I/O port address and IRQ 4 for the interrupt address. The options are Disabled, **3F8/IRQ4**, 3E8/IRQ4 and 2E8/IRQ3.

Serial Port2 Address

This option specifies the base I/O port address and Interrupt Request address of serial port 2. Select "Disabled" to prevent the serial port from accessing any system resources. When this option is set to "Disabled", the serial port physically becomes unavailable. Select "2F8/IRQ3" to allow the serial port to use 2F8 as its I/O port address and IRQ 3 for the interrupt address. The options are Disabled, **2F8/IRQ3**, 3E8/IRQ4 and 2E8/IRQ3.

Serial Port 2 Mode

Tells BIOS which mode to select for serial port 2. The options are **Normal**, Sharp-IR, SIR and Consumer.

► **Advanced Chipset Control**

NorthBridge Configuration

► **Memory Configuration**

Memclock Mode

This setting determines how the memory clock is set. **Auto** has the memory clock set by the code and **Limit** allows the user to set a standard value.

MCT Timing Mode

Sets the timing mode for memory. Options are **Auto** and **Manual**.

Bank Interleaving

This setting is used to determine whether bank interleaving is to be employed. The options are **Auto** and **Disabled**.

Enable Clock to All DIMMs

This setting allows the user to enable unused clocks to DIMMs, even if DIMM slots are empty. Options are **Enabled** and **Disabled**.

Mem Clk Tristate C3/ALTVID

Use this setting to **Enable** or **Disable** memory clock tristate during C3 and ALT VID.

Remapping Memory Hole

When "Enabled", allows software memory remapping around the memory hole (only supported by rev. E0 processors and above). Options are **Enabled** and **Disabled**.

Power Down Control

Allows DIMMs to enter power down mode by deasserting the clock enable signal when DIMMs are not in use. Options are **Auto** and **Disabled**.

Alternate VID

Specify the alternate VID while in low power states. Options are various voltages from .8V to 1.050V in increments of .025V. Default setting is **0.850V**.

▶ HT1000 SouthBridge Configuration

HIDE XIOAPIC PCI Functions

The options are **Yes** and **No**.

Legacy USB Support

Select "Enabled" to enable the support for USB Legacy. Disable Legacy support if there are no USB devices installed in the system. The options are **Enabled** and **Disabled**.

USB 2.0 Controller Mode

Select the controller mode for your USB ports. Options are **HiSpeed** and **FullSpeed**. (HiSpeed=480 Mbps, FullSpeed=12 Mbps).

BIOS EHCI Hand-Off

Enable or **Disable** a workaround for OS's without EHCI hand-off support.

▶ Event Log Configuration

View Event Log

Highlight this item and press <Enter> to view the contents of the event log.

Mark All Events as Read

Highlight this item and press <Enter> to mark the DMI events as read.

Clear Event Log

This setting will clear all event logs when set to "OK". The options are **OK** and **Cancel**.

Event Log Statistics

Highlight this item and press <Enter> to view details on the count of total unread events.

► Remote Access Configuration

Remote Access

Use this setting to Enable or **Disable** remote access. If Enabled is selected, you can select a Remote Access type.

► System Health Monitor

CPU Overheat Temperature

Use the "+" and "-" keys to set the CPU temperature threshold to between 65° and 90° C. When this threshold is exceeded, the overheat LED on the chassis will light up and an alarm will sound. The LED and alarm will turn off once the CPU temperature has dropped to 5 degrees below the threshold set. The default setting is **72° C**.

The other items in the submenu are all systems monitor displays for the following information:

CPU Temperature, System Temperature, CPU Vcore, +3.3V, +5 Vin, +12Vin, +5V standby and battery voltage.

Fan Speed Control Modes

This feature allows the user to determine how the system will control the speed of the onboard fans. Select "Workstation" if your system is used as a Workstation. Select "Server" if your system is used as a Server. Select "Disable" to disable the fan speed control function to allow the onboard fans to continuously run at full speed (12V). The options are **1) Disable, Full Speed** 2) Server Mode and 3) Workstation Mode.

FAN1 Speed through FAN5 Speed

The speeds of the onboard fans (in rpm) are displayed here.

7-4 Boot Menu

▶ **Boot Settings Configuration**

▶ **Boot Device Priority**

This feature allows the user to prioritize the sequence for the Boot Device with the devices installed in the system.

▶ **Hard Disk Drives**

This feature allows the user to prioritize the Boot sequence from available hard drives.

▶ **Removable Drives**

This feature allows the user to specify the Boot sequence from available removable drives.

▶ **CD/DVD Drives**

This feature allows the user to specify the boot sequence from available CDROM drives.

7-5 Security Menu

AMI BIOS provides a Supervisor and a User password. If you use both passwords, the Supervisor password must be set first.

Change Supervisor Password

Select this option and press <Enter> to access the sub menu, and then type in the password.

Change User Password

Select this option and press <Enter> to access the sub menu, and then type in the password.

Boot Sector Virus Protection

This option is near the bottom of the Security Setup screen. Select "Disabled" to deactivate the Boot Sector Virus Protection. Select "Enabled" to enable boot sector protection. When "Enabled", AMI BIOS displays a warning when any program (or virus) issues a Disk Format command or attempts to write to the boot sector of the hard disk drive. The options are Enabled and **Disabled**.

7-6 Exit Menu

Select the Exit tab from AMI BIOS Setup Utility screen to enter the Exit BIOS Setup screen.

Save Changes and Exit

When you have completed the system configuration changes, select this option to leave BIOS Setup and reboot the computer, so the new system configuration parameters can take effect. Select Save Changes and Exit from the Exit menu and press <Enter>.

Discard Changes and Exit

Select this option to quit BIOS Setup without making any permanent changes to the system configuration and reboot the computer. Select Discard Changes and Exit from the Exit menu and press <Enter>.

Discard Changes

Select this option and press <Enter> to discard all the changes and return to AMI BIOS Utility Program.

Load Optimal Defaults

To set this feature, select Load Optimal Defaults from the Exit menu and press <Enter>. Then Select "OK" to allow BIOS to automatically load the Optimal Defaults as the BIOS Settings. The Optimal settings are designed for maximum system performance, but may not work best for all computer applications.

Load Fail-Safe Defaults

To set this feature, select Load Fail-Safe Defaults from the Exit menu and press <Enter>. The Fail-Safe settings are designed for maximum system stability, but not maximum performance.

Appendix A

BIOS Error Beep Codes

During the POST (Power-On Self-Test) routines, which are performed each time the system is powered on, errors may occur.

Non-fatal errors are those which, in most cases, allow the system to continue the boot-up process. The error messages normally appear on the screen.

Fatal errors are those which will not allow the system to continue the boot-up procedure. If a fatal error occurs, you should consult with your system manufacturer for possible repairs.

These fatal errors are usually communicated through a series of audible beeps. The numbers on the fatal error list, on the following page, correspond to the number of beeps for the corresponding error. All errors listed, with the exception of Beep Code 8, are fatal errors.

POST codes may be read on the LEDs located beside the LAN port on the serverboard backplane. See the description of the POST code LEDs in Chapter 5.

A-1 AMIBIOS Error Beep Codes

Beep Code	Error Message	Description
1 beep	Refresh	Circuits have been reset. (Ready to power up.)
1 long, 5 short	Memory error	No memory detected in system
1 long, 8 short	Video error	Video adapter disabled or missing

Notes

Appendix B

BIOS POST Checkpoint Codes

When AMIBIOS performs the Power On Self Test, it writes checkpoint codes to I/O port 0080h. If the computer cannot complete the boot process, diagnostic equipment can be attached to the computer to read I/O port 0080h.

B-1 Uncompressed Initialization Codes

The uncompressed initialization checkpoint codes are listed in order of execution:

Checkpoint	Code Description
D0h	The NMI is disabled. Power on delay is starting. Next, the initialization code checksum will be verified.
D1h	Initializing the DMA controller, performing the keyboard controller BAT test, starting memory refresh and entering 4 GB flat mode next.
D3h	Starting memory sizing next.
D4h	Returning to real mode. Executing any OEM patches and setting the Stack next.
D5h	Passing control to the uncompressed code in shadow RAM at E000:0000h. The initialization code is copied to segment 0 and control will be transferred to segment 0.
D6h	Control is in segment 0. Next, checking if <Ctrl> <Home> was pressed and verifying the system BIOS checksum. If either <Ctrl> <Home> was pressed or the system BIOS checksum is bad, next will go to checkpoint code E0h. Otherwise, going to checkpoint code D7h.

B-2 Bootblock Recovery Codes

The bootblock recovery checkpoint codes are listed in order of execution:

Checkpoint	Code Description
E0h	The onboard floppy controller if available is initialized. Next, beginning the base 512 KB memory test.
E1h	Initializing the interrupt vector table next.
E2h	Initializing the DMA and Interrupt controllers next.
E6h	Enabling the floppy drive controller and Timer IRQs. Enabling internal cache memory.
Edh	Initializing the floppy drive.
Eeh	Looking for a floppy diskette in drive A:. Reading the first sector of the diskette.
Efh	A read error occurred while reading the floppy drive in drive A:.
F0h	Next, searching for the AMIBOOT.ROM file in the root directory.
F1h	The AMIBOOT.ROM file is not in the root directory.
F2h	Next, reading and analyzing the floppy diskette FAT to find the clusters occupied by the AMIBOOT.ROM file.
F3h	Next, reading the AMIBOOT.ROM file, cluster by cluster.
F4h	The AMIBOOT.ROM file is not the correct size.
F5h	Next, disabling internal cache memory.
FBh	Next, detecting the type of flash ROM.
FCh	Next, erasing the flash ROM.
FDh	Next, programming the flash ROM.
FFh	Flash ROM programming was successful. Next, restarting the system BIOS.

B-3 Uncompressed Initialization Codes

The following runtime checkpoint codes are listed in order of execution.

These codes are uncompressed in F0000h shadow RAM.

Checkpoint	Code Description
03h	The NMI is disabled. Next, checking for a soft reset or a power on condition.
05h	The BIOS stack has been built. Next, disabling cache memory.
06h	Uncompressing the POST code next.
07h	Next, initializing the CPU and the CPU data area.
08h	The CMOS checksum calculation is done next.
0Ah	The CMOS checksum calculation is done. Initializing the CMOS status register for date and time next.
0Bh	The CMOS status register is initialized. Next, performing any required initialization before the keyboard BAT command is issued.
0Ch	The keyboard controller input buffer is free. Next, issuing the BAT command to the keyboard controller.
0Eh	The keyboard controller BAT command result has been verified. Next, performing any necessary initialization after the keyboard controller BAT command test.
0Fh	The initialization after the keyboard controller BAT command test is done. The keyboard command byte is written next.
10h	The keyboard controller command byte is written. Next, issuing the Pin 23 and 24 blocking and unblocking command.
11h	Next, checking if <End or <Ins> keys were pressed during power on. Initializing CMOS RAM if the Initialize CMOS RAM in every boot AMIBIOS POST option was set in AMIBCP or the <End> key was pressed.
12h	Next, disabling DMA controllers 1 and 2 and interrupt controllers 1 and 2.
13h	The video display has been disabled. Port B has been initialized. Next, initializing the chipset.
14h	The 8254 timer test will begin next.
19h	Next, programming the flash ROM.
1Ah	The memory refresh line is toggling. Checking the 15 second on/off time next.
2Bh	Passing control to the video ROM to perform any required configuration before the video ROM test.
2Ch	All necessary processing before passing control to the video ROM is done. Looking for the video ROM next and passing control to it.
2Dh	The video ROM has returned control to BIOS POST. Performing any required processing after the video ROM had control
23h	Reading the 8042 input port and disabling the MEGAKEY Green PC feature next. Making the BIOS code segment writable and performing any necessary configuration before initializing the interrupt vectors.
24h	The configuration required before interrupt vector initialization has completed. Interrupt vector initialization is about to begin.

Checkpoint	Code Description
25h	Interrupt vector initialization is done. Clearing the password if the POST DIAG switch is on.
27h	Any initialization before setting video mode will be done next.
28h	Initialization before setting the video mode is complete. Configuring the monochrome mode and color mode settings next.
2Ah	Bus initialization system, static, output devices will be done next, if present. See the last page for additional information.
2Eh	Completed post-video ROM test processing. If the EGA/VGA controller is not found, performing the display memory read/write test next.
2Fh	The EGA/VGA controller was not found. The display memory read/write test is about to begin.
30h	The display memory read/write test passed. Look for retrace checking next.
31h	The display memory read/write test or retrace checking failed. Performing the alternate display memory read/write test next.
32h	The alternate display memory read/write test passed. Looking for alternate display retrace checking next.
34h	Video display checking is over. Setting the display mode next.
37h	The display mode is set. Displaying the power on message next.
38h	Initializing the bus input, IPL, general devices next, if present. See the last page of this chapter for additional information.
39h	Displaying bus initialization error messages. See the last page of this chapter for additional information.
3Ah	The new cursor position has been read and saved. Displaying the Hit message next.
3Bh	The Hit message is displayed. The protected mode memory test is about to start.
40h	Preparing the descriptor tables next.
42h	The descriptor tables are prepared. Entering protected mode for the memory test next.
43h	Entered protected mode. Enabling interrupts for diagnostics mode next.
44h	Interrupts enabled if the diagnostics switch is on. Initializing data to check memory wraparound at 0:0 next.
45h	Data initialized. Checking for memory wraparound at 0:0 and finding the total system memory size next.
46h	The memory wraparound test is done. Memory size calculation has been done. Writing patterns to test memory next.
47h	The memory pattern has been written to extended memory. Writing patterns to the base 640 KB memory next.
48h	Patterns written in base memory. Determining the amount of memory below 1 MB next.
49h	The amount of memory below 1 MB has been found and verified.
4Bh	The amount of memory above 1 MB has been found and verified. Checking for a soft reset and clearing the memory below 1 MB for the soft reset next. If this is a power on situation, going to checkpoint 4Eh next.

Checkpoint	Code Description
4Ch	The memory below 1 MB has been cleared via a soft reset. Clearing the memory above 1 MB next.
4Dh	The memory above 1 MB has been cleared via a soft reset. Saving the memory size next. Going to checkpoint 52h next.
4Eh	The memory test started, but not as the result of a soft reset. Displaying the first 64 KB memory size next.
4Fh	The memory size display has started. The display is updated during the memory test. Performing the sequential and random memory test next.
50h	The memory below 1 MB has been tested and initialized. Adjusting the displayed memory size for relocation and shadowing next.
51h	The memory size display was adjusted for relocation and shadowing.
52h	The memory above 1 MB has been tested and initialized. Saving the memory size information next.
53h	The memory size information and the CPU registers are saved. Entering real mode next.
54h	Shutdown was successful. The CPU is in real mode. Disabling the Gate A20 line, parity, and the NMI next.
57h	The A20 address line, parity, and the NMI are disabled. Adjusting the memory size depending on relocation and shadowing next.
58h	The memory size was adjusted for relocation and shadowing. Clearing the Hit message next.
59h	The Hit message is cleared. The <WAIT...> message is displayed. Starting the DMA and interrupt controller test next.
60h	The DMA page register test passed. Performing the DMA Controller 1 base register test next.
62h	The DMA controller 1 base register test passed. Performing the DMA controller 2 base register test next.
65h	The DMA controller 2 base register test passed. Programming DMA controllers 1 and 2 next.
66h	Completed programming DMA controllers 1 and 2. Initializing the 8259 interrupt controller next.
67h	Completed 8259 interrupt controller initialization.
7Fh	Extended NMI source enabling is in progress.
80h	The keyboard test has started. Clearing the output buffer and checking for stuck keys. Issuing the keyboard reset command next.
81h	A keyboard reset error or stuck key was found. Issuing the keyboard controller interface test command next.
82h	The keyboard controller interface test completed. Writing the command byte and initializing the circular buffer next.
83h	The command byte was written and global data initialization has completed. Checking for a locked key next.
84h	Locked key checking is over. Checking for a memory size mismatch with CMOS RAM data next.
85h	The memory size check is done. Displaying a soft error and checking for a password or bypassing WINBIOS Setup next.

Checkpoint	Code Description
86h	The password was checked. Performing any required programming before WINBIOS Setup next.
87h	The programming before WINBIOS Setup has completed. Uncompressing the WINBIOS Setup code and executing the AMIBIOS Setup or WINBIOS Setup utility next.
88h	Returned from WINBIOS Setup and cleared the screen. Performing any necessary programming after WINBIOS Setup next.
89h	The programming after WINBIOS Setup has completed. Displaying the power on screen message next.
8Ch	Programming the WINBIOS Setup options next.
8Dh	The WINBIOS Setup options are programmed. Resetting the hard disk controller next.
8Fh	The hard disk controller has been reset. Configuring the floppy drive controller next.
91h	The floppy drive controller has been configured. Configuring the hard disk drive controller next.
95h	Initializing the bus option ROMs from C800 next. See the last page of this chapter for additional information.
96h	Initializing before passing control to the adaptor ROM at C800.
97h	Initialization before the C800 adaptor ROM gains control has completed. The adaptor ROM check is next.
98h	The adaptor ROM had control and has now returned control to BIOS POST. Performing any required processing after the option ROM returned control.
99h	Any initialization required after the option ROM test has completed. Configuring the timer data area and printer base address next.
9Ah	Set the timer and printer base addresses. Setting the RS-232 base address next.
9Bh	Returned after setting the RS-232 base address. Performing any required initialization before the Coprocessor test next.
9Ch	Required initialization before the Coprocessor test is over. Initializing the Coprocessor next.
9Dh	Coprocessor initialized. Performing any required initialization after the Coprocessor test next.
9Eh	Initialization after the Coprocessor test is complete. Checking the extended keyboard, keyboard ID, and Num Lock key next. Issuing the keyboard ID command next.
A2h	Displaying any soft errors next.
A3h	The soft error display has completed. Setting the keyboard typematic rate next.
A4h	The keyboard typematic rate is set. Programming the memory wait states next.
A5h	Memory wait state programming is over. Clearing the screen and enabling parity and the NMI next.
A7h	NMI and parity enabled. Performing any initialization required before passing control to the adaptor ROM at E000 next.
A8h	Initialization before passing control to the adaptor ROM at E000h completed. Passing control to the adaptor ROM at E000h next.

Checkpoint	Code Description
A9h	Returned from adaptor ROM at E000h control. Performing any initialization required after the E000 option ROM had control next.
Aah	Initialization after E000 option ROM control has completed. Displaying the system configuration next.
Abh	Uncompressing the DMI data and executing DMI POST initialization next.
B0h	The system configuration is displayed.
B1h	Copying any code to specific areas.
00h	Code copying to specific areas is done. Passing control to INT 19h boot loader next.

Notes

Appendix C

System Specifications

Processors

Single AMD Opteron Series 1000 processor in a 940-pin AM2 socket

Note: Please refer to our web site for a complete listing of supported processors.

Chipset

ServerWorks HT-1000 chipset

BIOS

4 Mb AMI BIOS® Flash ROM

Memory Capacity

Four 240-pin DIMM sockets supporting up to 8 GB of ECC/non-ECC unbuffered DDR2-800/667/533 SDRAM

Note: See the memory section in Chapter 5 for details.

Serial ATA Controller

ServerWorks on-chip controller

Serial ATA Drive Bays

One (1) internal drive bay

Peripheral Drive Bays

One (1) slim CD-ROM drive

Expansion Slots (provided with included riser card)

One (1) riser card to support the use of one full height, half-length 133/100MHz 64-bit PCI-X expansion card

Motherboard

Model: H8SSL-i2 (ATX form factor)

Dimensions: 8 x 12 in (203 x 305 mm)

Chassis

Model: SC512F-260 Form Factor: 1U rackmount

Dimensions: (WxHxD) 16.8 x 1.7 x 14 in. (427 x 43 x 356 mm)

Weight

Net (Gross): 17 lbs. (7.7 kg.)

System Cooling

Two 4-cm counter-rotating fans

System Input Requirements

AC Input Voltage: 100-240 VAC (auto-range)

Rated Input Current: 4A max.

Rated Input Frequency: 50 to 60 Hz

Power Supply

Rated Output Power: 260W (Model# SP262-1S, Part# PWS-0055)

Rated Output Voltages: +3.3V (15A), +5V (25A), +12V (18A), -12V (1A), +5Vsb (2A)

BTU Rating

1400 BTUs/hr (for rated output power of 260W)

Operating Environment

Operating Temperature: 10° to 35° C (50° to 95° F)

Non-operating Temperature: -40° to 70° C (-40° to 158° F)

Operating Relative Humidity: 8% to 90% (non-condensing)

Non-operating Relative Humidity: 5 to 95% (non-condensing)

Regulatory Compliance

Electromagnetic Emissions:

FCC Class B, EN 55022 Class B, EN 61000-3-2/-3-3, CISPR 22 Class B

Electromagnetic Immunity:

EN 55024/CISPR 24, (EN 61000-4-2, EN 61000-4-3, EN 61000-4-4,
EN 61000-4-5, EN 61000-4-6, EN 61000-4-8, EN 61000-4-11)

Safety:

EN 60950/IEC 60950-Compliant, UL Listed (USA), CUL Listed (Canada), TUV
Certified (Germany), CE Marking (Europe)

(continued from front)

The products sold by Supermicro are not intended for and will not be used in life support systems, medical equipment, nuclear facilities or systems, aircraft, aircraft devices, aircraft/emergency communication devices or other critical systems whose failure to perform be reasonably expected to result in significant injury or loss of life or catastrophic property damage. Accordingly, Supermicro disclaims any and all liability, and should buyer use or sell such products for use in such ultra-hazardous applications, it does so entirely at its own risk. Furthermore, buyer agrees to fully indemnify, defend and hold Supermicro harmless for and against any and all claims, demands, actions, litigation, and proceedings of any kind arising out of or related to such ultra-hazardous use or sale.