

SUPERO[®]

SUPERSERVER 6015W-UR
SUPERSERVER 6015W-U
SUPERSERVER 6015W-NTR
SUPERSERVER 6015W-NT

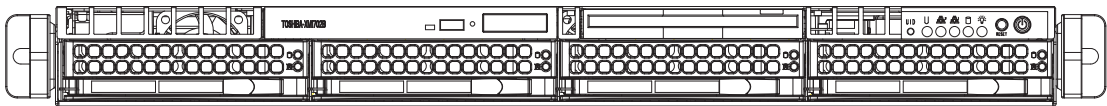

USER'S MANUAL

1.0b

The information in this User's Manual has been carefully reviewed and is believed to be accurate. The vendor assumes no responsibility for any inaccuracies that may be contained in this document, makes no commitment to update or to keep current the information in this manual, or to notify any person or organization of the updates. **Please Note: For the most up-to-date version of this manual, please see our web site at www.supermicro.com.**

SUPER MICRO COMPUTER reserves the right to make changes to the product described in this manual at any time and without notice. This product, including software, if any, and documentation may not, in whole or in part, be copied, photocopied, reproduced, translated or reduced to any medium or machine without prior written consent.

IN NO EVENT WILL SUPER MICRO COMPUTER BE LIABLE FOR DIRECT, INDIRECT, SPECIAL, INCIDENTAL, SPECULATIVE OR CONSEQUENTIAL DAMAGES ARISING FROM THE USE OR INABILITY TO USE THIS PRODUCT OR DOCUMENTATION, EVEN IF ADVISED OF THE POSSIBILITY OF SUCH DAMAGES. IN PARTICULAR, SUPER MICRO SHALL NOT HAVE LIABILITY FOR ANY HARDWARE, SOFTWARE, OR DATA STORED OR USED WITH THE PRODUCT, INCLUDING THE COSTS OF REPAIRING, REPLACING, INTEGRATING, INSTALLING OR RECOVERING SUCH HARDWARE, SOFTWARE, OR DATA.

Any disputes arising between manufacturer and customer shall be governed by the laws of Santa Clara County in the State of California, USA. The State of California, County of Santa Clara shall be the exclusive venue for the resolution of any such disputes. Super Micro's total liability for all claims will not exceed the price paid for the hardware product.

FCC Statement: This equipment has been tested and found to comply with the limits for a Class A digital device pursuant to Part 15 of the FCC Rules. These limits are designed to provide reasonable protection against harmful interference when the equipment is operated in a commercial environment. This equipment generates, uses, and can radiate radio frequency energy and, if not installed and used in accordance with the manufacturer's instruction manual, may cause harmful interference with radio communications. Operation of this equipment in a residential area is likely to cause harmful interference, in which case you will be required to correct the interference at your own expense.

WARNING: Handling of lead solder materials used in this product may expose you to lead, a chemical known to the State of California to cause birth defects and other reproductive harm.

Manual Revision 1.0b

Release Date: July 6, 2009

Unless you request and receive written permission from SUPER MICRO COMPUTER, you may not copy any part of this document.

Information in this document is subject to change without notice. Other products and companies referred to herein are trademarks or registered trademarks of their respective companies or mark holders.

Copyright © 2009 by SUPER MICRO COMPUTER INC.
All rights reserved.

Printed in the United States of America

Preface

About This Manual

This manual is written for professional system integrators and PC technicians. It provides information for the installation and use of the SuperServer 6015W-UR/6015W-U/6015W-NTR/6015W-NT. Installation and maintenance should be performed by experienced technicians only.

The SuperServer 6015W-UR/6015W-U/6015W-NTR/6015W-NT is a high-end server based on the SC815TQ-R650U/SC815TQ-560U 1U rackmount chassis and the Super X7DWU, a dual processor serverboard that supports Intel® Xeon® 5400/5300LV/5200/5100LV series processors at a Front Side (System) Bus speed of 1600/1333/1066 MHz and up to 64 GB of ECC FBD DDR2-800/667 SDRAM.

Manual Organization

Chapter 1: Introduction

The first chapter provides a checklist of the main components included with the server system and describes the main features of the X7DWU serverboard and the SC815TQ-R650U/SC815TQ-560U chassis, which comprise the SuperServer 6015W-UR/6015W-U/6015W-NTR/6015W-NT.

Chapter 2: Server Installation

This chapter describes the steps necessary to install the SuperServer 6015W-UR/6015W-U/6015W-NTR/6015W-NT into a rack and check out the server configuration prior to powering up the system. If your server was ordered without processor and memory components, this chapter will refer you to the appropriate sections of the manual for their installation.

Chapter 3: System Interface

Refer here for details on the system interface, which includes the functions and information provided by the control panel on the chassis as well as other LEDs located throughout the system.

Chapter 4: System Safety

You should thoroughly familiarize yourself with this chapter for a general overview of safety precautions that should be followed when installing and servicing the SuperServer 6015W-UR/6015W-U/6015W-NTR/6015W-NT.

Chapter 5: Advanced Serverboard Setup

Chapter 5 provides detailed information on the X7DWU serverboard, including the locations and functions of connections, headers and jumpers. Refer to this chapter when adding or removing processors or main memory and when reconfiguring the serverboard.

Chapter 6: Advanced Chassis Setup

Refer to Chapter 6 for detailed information on the SC815TQ-R650U/SC815TQ-560U server chassis. You should follow the procedures given in this chapter when installing, removing or reconfiguring SATA or peripheral drives and when replacing system power supply modules and cooling fans.

Chapter 7: BIOS

The BIOS chapter includes an introduction to BIOS and provides detailed information on running the CMOS Setup Utility.

Appendix A: BIOS POST Messages

Appendix B: BIOS POST Codes

Appendix C: System Specifications

Notes

Table of Contents

Chapter 1 Introduction

1-1	Overview	1-1
1-2	Serverboard Features	1-2
	Processors	1-2
	Memory	1-2
	UIO (6015W-UR/6015W-U).....	1-2
	Serial ATA.....	1-2
	Onboard Controllers/Ports	1-2
	ATI Graphics Controller.....	1-3
	Other Features	1-3
1-3	Server Chassis Features	1-3
	System Power	1-3
	SATA Subsystem.....	1-3
	PCI Expansion Slots	1-3
	Front Control Panel.....	1-4
	I/O Backplane.....	1-4
	Cooling System	1-4
1-4	Contacting Supermicro.....	1-6

Chapter 2 Server Installation

2-1	Overview	2-1
2-2	Unpacking the System	2-1
2-3	Preparing for Setup.....	2-1
	Choosing a Setup Location.....	2-2
	Rack Precautions	2-2
	Server Precautions.....	2-2
	Rack Mounting Considerations	2-3
	Ambient Operating Temperature	2-3
	Reduced Airflow	2-3
	Mechanical Loading	2-3
	Circuit Overloading.....	2-3
	Reliable Ground	2-3
2-4	Installing the System into a Rack	2-4
	Identifying the Sections of the Rack Rails	2-4
	Installing the Inner Rails	2-4
	Installing the Outer Rails.....	2-5
	Installing the Server into the Rack.....	2-6

Installing the Server into a Telco Rack	2-7
2-5 Checking the Serverboard Setup.....	2-8
2-6 Checking the Drive Bay Setup.....	2-9
Chapter 3 System Interface	
3-1 Overview	3-1
3-2 Control Panel Buttons	3-1
UID	3-1
Reset.....	3-1
Power	3-2
3-3 Control Panel LEDs	3-2
Universal Information LED	3-2
NIC2	3-3
NIC1	3-3
HDD.....	3-3
Power	3-3
3-4 SATA Drive Carrier LEDs	3-4
Chapter 4 System Safety	
4-1 Electrical Safety Precautions	4-1
4-2 General Safety Precautions	4-2
4-3 ESD Precautions.....	4-3
4-4 Operating Precautions	4-4
Chapter 5 Advanced Serverboard Setup	
5-1 Handling the Serverboard	5-1
Precautions	5-1
Unpacking	5-1
5-2 Processor and Heatsink Installation.....	5-2
5-3 Connecting Cables.....	5-5
Connecting Data Cables	5-5
Connecting Power Cables	5-5
Connecting the Control Panel.....	5-5
5-4 I/O Ports	5-6
5-5 Installing Memory	5-7
5-6 Adding PCI Cards	5-9
5-7 Serverboard Details	5-10
X7DWU Quick Reference	5-11
5-8 Connector Definitions	5-12
5-9 Jumper Settings	5-18
5-10 Onboard Indicators.....	5-21

5-11	Floppy, IDE and SATA Drive Connections	5-22
5-12	Installing Drivers.....	5-24

Chapter 6 Advanced Chassis Setup

6-1	Static-Sensitive Devices.....	6-1
	Precautions	6-1
6-2	Control Panel	6-2
6-3	System Fans	6-3
	System Fan Failure.....	6-3
6-4	Drive Bay Installation/Removal	6-4
	Removing the Front Bezel	6-4
	Accessing the Drive Bays.....	6-5
	SATA Drive Installation.....	6-6
	DVD-ROM and Floppy Drive Installation	6-8
6-5	Power Supply	6-9
	6015W-UR/6015W-NTR.....	6-9
	Power Supply Failure	6-9
	6015W-U/6015W-NT	6-10
	Power Supply Failure	6-10

Chapter 7 BIOS

7-1	Introduction.....	7-1
7-2	Running Setup	7-2
7-3	Main BIOS Setup	7-2
7-4	Advanced Setup.....	7-7
7-5	Security	7-22
7-6	Boot.....	7-24
7-7	Exit	7-25

Appendix A BIOS POST Messages

Appendix B BIOS POST Codes

Appendix C System Specifications

Chapter 1

Introduction

1-1 Overview

The SuperServer 6015W-UR/6015W-U/6015W-NTR/6015W-NT is a high-end server comprised of two main subsystems: the SC815TQ-R650U (6015W-UR/6015W-NTR)/SC815TQ-560U (6015W-U/6015W-NT) 1U server chassis and the X7DWU dual processor serverboard. Please refer to our web site for information on operating systems that have been certified for use with the system (www.supermicro.com).

In addition to the serverboard and chassis, various hardware components have been included with the 6015W-UR/6015W-U/6015W-NTR/6015W-NT, as listed below:

- One (1) slim DVD-ROM drive [DVM-PNSC-824(B/V)]
- Four (4) sets of 4-cm counter-rotating fans (FAN-0086L)
- One (1) DVD cable (CBL-0139L)
- Two (2) passive CPU heatsinks (SNK-P0017)
- Riser Cards: (see Section 5-6 for details)
 - One (1) RSC-R1UU-E8R+ for PCI-X card
 - One (1) RSC-R1UU-UE8 for PCI-E card (6015W-UR/6015W-U only)
 - One (1) RSC-R1UU-2E8 for two PCI-E cards (6015W-NTR/6015W-NT only)
- SATA Accessories
 - One (1) SATA backplane (BPN-SAS-815TQ)
 - One (1) SATA iPASS cable (CBL-0188L) (6015W-UR/6015W-U only)
 - Four (4) SAS drive carriers (MCP-220-00001-01)
 - One (1) SATA cable (CBL-0190L) (6015W-NTR/6015W-NT only)
 - One (1) SGPIO cable (CBL-0157) (6015W-NTR/6015W-NT only)
- One (1) rackmount kit (CSE-PT51L)
- One (1) CD containing drivers and utilities
- SuperServer 6015W-UR/6015W-U/6015W-NTR/6015W-NT User's Manual

Note: a "V" at the end of a server name indicates the chassis is silver and "B" indicates black..

1-2 Serverboard Features

At the heart of the SuperServer 6015W-UR/6015W-U/6015W-NTR/6015W-NT lies the X7DWU, a dual processor serverboard based on Intel's 5400 chipset. Below are the main features of the X7DWU (see Figure 1-1 for a block diagram of the chipset).

Processors

The X7DWU supports single or dual Intel Xeon LGA-771 5400/5300LV/5200/5100LV series processors at a FSB speed of 1600/1333/1066 MHz. Please refer to the serverboard description pages on our web site for a complete listing of supported processors.

Memory

The X7DWU has eight 240-pin DIMM sockets that can support up to 64 GB of ECC FBD (Fully Buffered DIMM) DDR2-800, DDR2-667 or DDR2-533 SDRAM. The memory is an interleaved configuration, which requires modules of the same size and speed to be installed in pairs. Please refer to Chapter 5 for memory speed jumper settings.

UIO (6015W-UR/6015W-U)

The X7DWU is a specially-designed serverboard that features Supermicro's UIO (Universal I/O) technology. UIO serverboards have a PCI-Express x8 connector that can support any one of several types of UIO card types to add SAS ports, additional LAN ports, etc. to the serverboard. This allows the user to tailor the serverboard to their own needs. Note: the 6015W-UR/6015W-U does not come with a UIO card installed.

Serial ATA

An on-chip (ESB2) SATA controller is integrated into the X7DWU to provide a six-port, 3 Gb/sec Serial ATA subsystem, which is RAID 0, 1 and 10 supported. The SATA drives are hot-swappable units. Note: The operating system you use must have RAID support to enable the hot-swap capability and RAID function of the Serial ATA drives.

Onboard Controllers/Ports

One floppy drive controller and one onboard ATA/100 controller are provided to support up to two IDE hard drives or ATAPI devices. The color-coded I/O ports

include one COM port, a VGA (monitor) port, two USB 2.0 ports, PS/2 mouse and keyboard ports and two gigabit Ethernet ports.

ATI Graphics Controller

The X7DWU features an integrated ATI video controller based on the ES1000 graphics chip. The ES1000 was designed specifically for servers, featuring low power consumption, high reliability and superior longevity.

Other Features

Other onboard features that promote system health include onboard voltage monitors, a chassis intrusion header, auto-switching voltage regulators, chassis and CPU overheat sensors, virus protection and BIOS rescue.

1-3 Server Chassis Features

The 6015W-UR/6015W-NTR is built upon the SC815TQ-R650U chassis while the 6015W-U/6015W-NT is built upon the SC815TQ-560U chassis. The following is a general outline of the main features of both chassis.

System Power

The SC815TQ-R650U features a redundant 650W power supply consisting of two power modules. The system does not need to be shut down when replacing or removing a single power supply module.

The SC815TQ-560U features a single 560W power supply module. The system must be shut down when replacing or removing this power supply module.

SATA Subsystem

The SC815TQ-R650U/SC815TQ-560U chassis was designed to support four hot-swap SATA hard drives. Note: In the 6015W-NTR/6015W-NT, SATA drives are connected to the onboard SATA ports.

PCI Expansion Slots

6015W-UR/6015W-U: A riser card on the right side of the chassis can support one PCI-E x8 card (with a maximum length of 5.5"). The left side supports a UIO card and one PCI-E x8 card. These two systems can support four SAS/SATA drives with an optional UIO SAS card. See our web site for details (<http://www.supermicro.com/products/nfo/UIO.cfm>).

6015W-NTR/6015W-NT: A riser card on the right side of the chassis can support one PCI-E x8 card. The left side supports two PCI-E x8 cards. See section 5-6 for details. (Right and left refer to the side when viewed from the front of the system. The 6015W-NTR/6015W-NT does not support a UIO card.)

Front Control Panel

The chassis' control panel provides you with system monitoring and control. LEDs indicate system power, HDD activity, network activity (two) and UID/overheat/fan fail/power fail. A main power button and system reset button is also included.

I/O Backplane

The SC815TQ-R650U/SC815TQ-560U is an extended ATX form factor chassis that is designed to be used in a 1U rackmount configuration. Ports on the I/O backplane include one COM port, a VGA port, two USB 2.0 ports, PS/2 mouse and keyboard ports and two gigabit Ethernet ports. A UID (Unit Identifier) button and LED are also located beside the LAN2 Ethernet port.

Cooling System

The SC815TQ-R650U/SC815TQ-560U chassis has an innovative cooling design that features four sets of 4-cm counter-rotating fans located in the middle section of the chassis. There is a "Fan Speed Control Mode" setting in BIOS that allows chassis fan speed to be determined by system temperature. The power supply module also includes a cooling fan.

**Figure 1-1. Intel 5400 Chipset:
System Block Diagram**

Note: This is a general block diagram. Please see Chapter 5 for details.

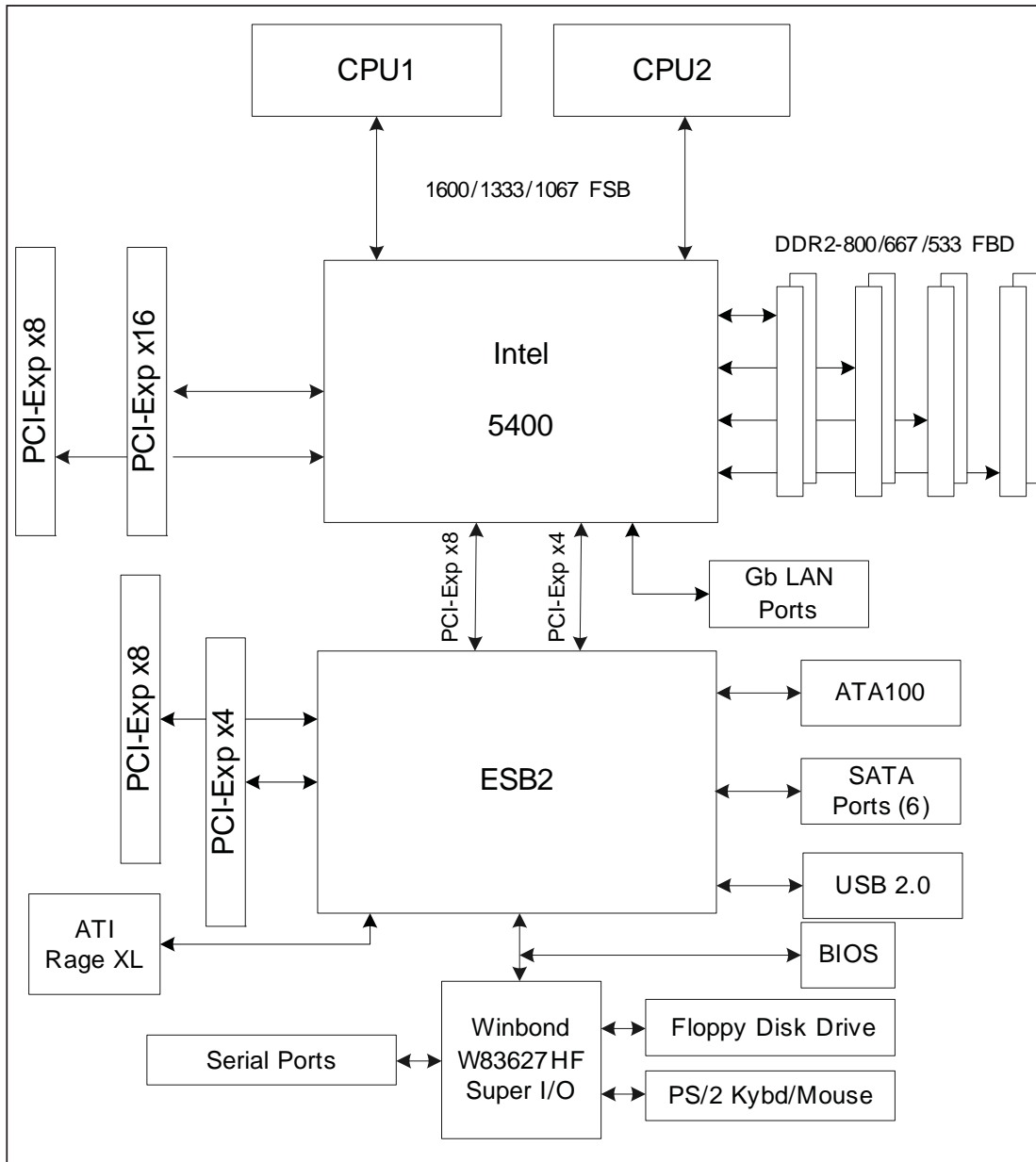

1-4 Contacting Supermicro

Headquarters

Address: Super Micro Computer, Inc.
980 Rock Ave.
San Jose, CA 95131 U.S.A.

Tel: +1 (408) 503-8000

Fax: +1 (408) 503-8008

Email: marketing@supermicro.com (General Information)
support@supermicro.com (Technical Support)

Web Site: www.supermicro.com

Europe

Address: Super Micro Computer B.V.
Het Sterrenbeeld 28, 5215 ML
's-Hertogenbosch, The Netherlands

Tel: +31 (0) 73-6400390

Fax: +31 (0) 73-6416525

Email: sales@supermicro.nl (General Information)
support@supermicro.nl (Technical Support)
rma@supermicro.nl (Customer Support)

Asia-Pacific

Address: Super Micro Computer, Inc.
4F, No. 232-1, Liancheng Rd.
Chung-Ho 235, Taipei County
Taiwan, R.O.C.

Tel: +886-(2) 8226-3990

Fax: +886-(2) 8226-3991

Web Site: www.supermicro.com.tw

Technical Support:

Email: support@supermicro.com.tw

Tel: 886-2-8228-1366, ext.132 or 139

Chapter 2

Server Installation

2-1 Overview

This chapter provides a quick setup checklist to get your SuperServer 6015W-UR/6015W-U/6015W-NTR/6015W-NT up and running. Following these steps in the order given should enable you to have the system operational within a minimum amount of time. This quick setup assumes that your system has come to you with the processors and memory preinstalled. If your system is not already fully integrated with a serverboard, processors, system memory etc., please turn to the chapter or section noted in each step for details on installing specific components.

2-2 Unpacking the System

You should inspect the box the SuperServer 6015W-UR/6015W-U/6015W-NTR/6015W-NT was shipped in and note if it was damaged in any way. If the server itself shows damage you should file a damage claim with the carrier who delivered it.

Decide on a suitable location for the rack unit that will hold the 6015W-UR/6015W-U/6015W-NTR/6015W-NT. It should be situated in a clean, dust-free area that is well ventilated. Avoid areas where heat, electrical noise and electromagnetic fields are generated. You will also need it placed near a grounded power outlet. Be sure to read the Rack and Server Precautions in the next section.

2-3 Preparing for Setup

The box the SuperServer 6015W-UR/6015W-U/6015W-NTR/6015W-NT was shipped in should include two sets of rail assemblies, two rail mounting brackets and the mounting screws you will need to install the system into the rack. Follow the steps in the order given to complete the installation process in a minimum amount of time. Please read this section in its entirety before you begin the installation procedure outlined in the sections that follow.

Choosing a Setup Location

- Leave enough clearance in front of the rack to enable you to open the front door completely (~25 inches) and approximately 30 inches of clearance in the back of the rack to allow for sufficient airflow and ease in servicing. This product is for installation only in a Restricted Access Location (dedicated equipment rooms, service closets and the like).
- This product is not suitable for use with visual display work place devices according to §2 of the the German Ordinance for Work with Visual Display Units.



Warnings and Precautions!



Rack Precautions

- Ensure that the leveling jacks on the bottom of the rack are fully extended to the floor with the full weight of the rack resting on them.
- In single rack installation, stabilizers should be attached to the rack. In multiple rack installations, the racks should be coupled together.
- Always make sure the rack is stable before extending a component from the rack.
- You should extend only one component at a time - extending two or more simultaneously may cause the rack to become unstable.

Server Precautions

- Review the electrical and general safety precautions in Chapter 4.
- Determine the placement of each component in the rack *before* you install the rails.
- Install the heaviest server components on the bottom of the rack first, and then work up.
- Use a regulating uninterruptible power supply (UPS) to protect the server from power surges, voltage spikes and to keep your system operating in case of a power failure.

- Allow the hot plug SATA drives and power supply modules to cool before touching them.
- Always keep the rack's front door and all panels and components on the servers closed when not servicing to maintain proper cooling.

Rack Mounting Considerations

Ambient Operating Temperature

If installed in a closed or multi-unit rack assembly, the ambient operating temperature of the rack environment may be greater than the ambient temperature of the room. Therefore, consideration should be given to installing the equipment in an environment compatible with the manufacturer's maximum rated ambient temperature (Tmra).

Reduced Airflow

Equipment should be mounted into a rack so that the amount of airflow required for safe operation is not compromised.

Mechanical Loading

Equipment should be mounted into a rack so that a hazardous condition does not arise due to uneven mechanical loading.

Circuit Overloading

Consideration should be given to the connection of the equipment to the power supply circuitry and the effect that any possible overloading of circuits might have on overcurrent protection and power supply wiring. Appropriate consideration of equipment nameplate ratings should be used when addressing this concern.

Reliable Ground

A reliable ground must be maintained at all times. To ensure this, the rack itself should be grounded. Particular attention should be given to power supply connections other than the direct connections to the branch circuit (i.e. the use of power strips, etc.).

2-4 Installing the System into a Rack

This section provides information on installing the 6015W-UR/6015W-U/6015W-NTR/6015W-NT into a rack unit with the rack rails provided. If the system has already been mounted into a rack, you can skip ahead to Sections 2-5 and 2-6.

There are a variety of rack units on the market, which may mean the assembly procedure will differ slightly. You should also refer to the installation instructions that came with the rack unit you are using.

Identifying the Sections of the Rack Rails

You should have received two rack rail assemblies in the rack mounting kit. Each assembly consists of two sections: an inner fixed chassis rail that secures directly to the server chassis and an outer fixed rack rail that secures directly to the rack itself (see Figure 2-1). Two pairs of short brackets to be used when installing to a telco (open) rack are also included.

Installing the Inner Rails

Both the left and right side inner rails have been pre-installed to the chassis. Proceed to the next step.

**Figure 2-1. Identifying the Sections of the Rack Rails
(right side rail shown)**

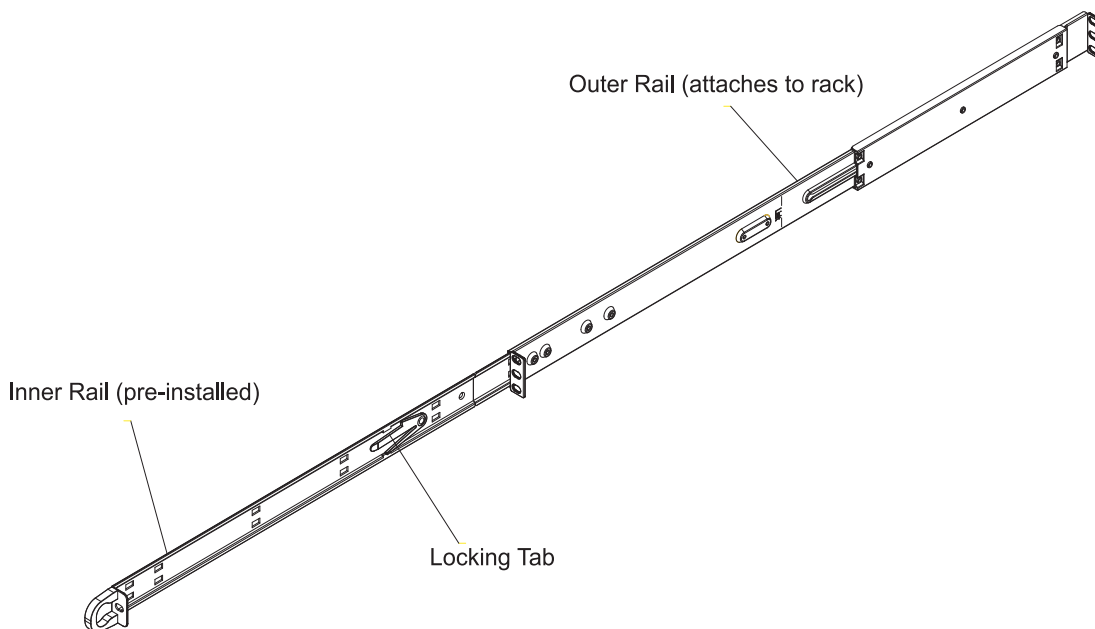

Installing the Outer Rails

Begin by measuring the distance from the front rail to the rear rail of the rack. Adjust the outer rail pieces to the proper length so that the rail fits the rack. Secure the outer rail with the screws provided. Repeat these steps for both outer rails.

Locking Tabs: Both chassis rails have a locking tab, which serves two functions. The first is to lock the server into place when installed and pushed fully into the rack, which is its normal position. Secondly, these tabs also lock the server in place when fully extended from the rack. This prevents the server from coming completely out of the rack when you pull it out for servicing.

Figure 2-2. Installing the Rack Rails

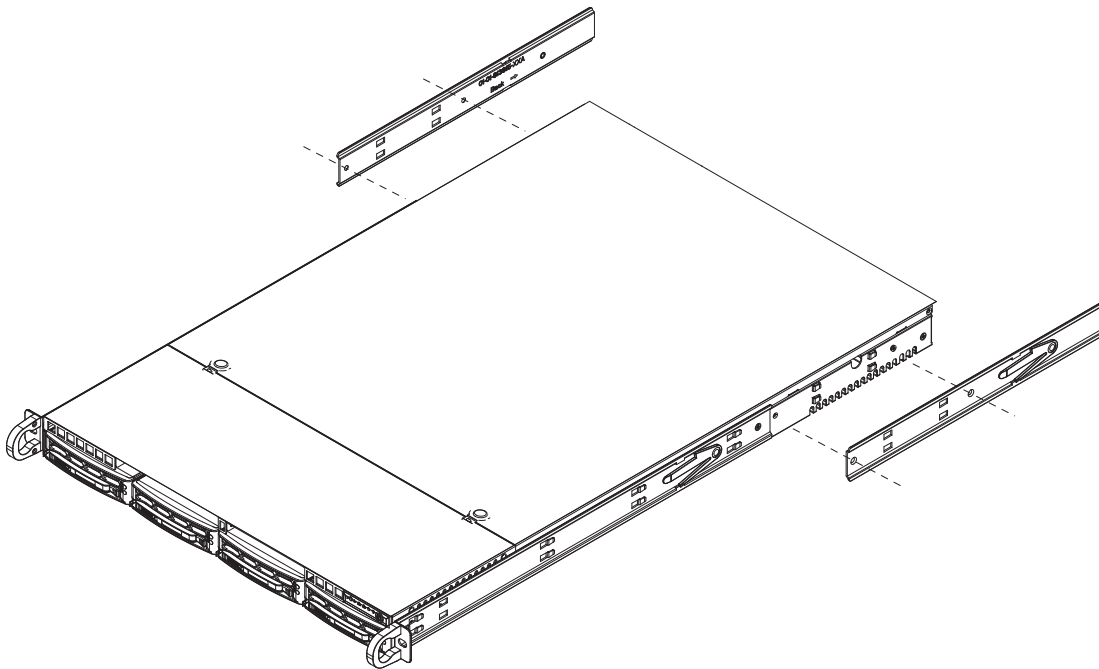

Installing the Server into the Rack

You should now have rails attached to both the chassis and the rack unit. The next step is to install the server into the rack. Do this by lining up the rear of the chassis rails with the front of the rack rails. Slide the chassis rails into the rack rails, keeping the pressure even on both sides (you may have to depress the locking tabs when inserting). See Figure 2-3.

When the server has been pushed completely into the rack, you should hear the locking tabs "click".

Figure 2-3. Installing the Server into a Rack

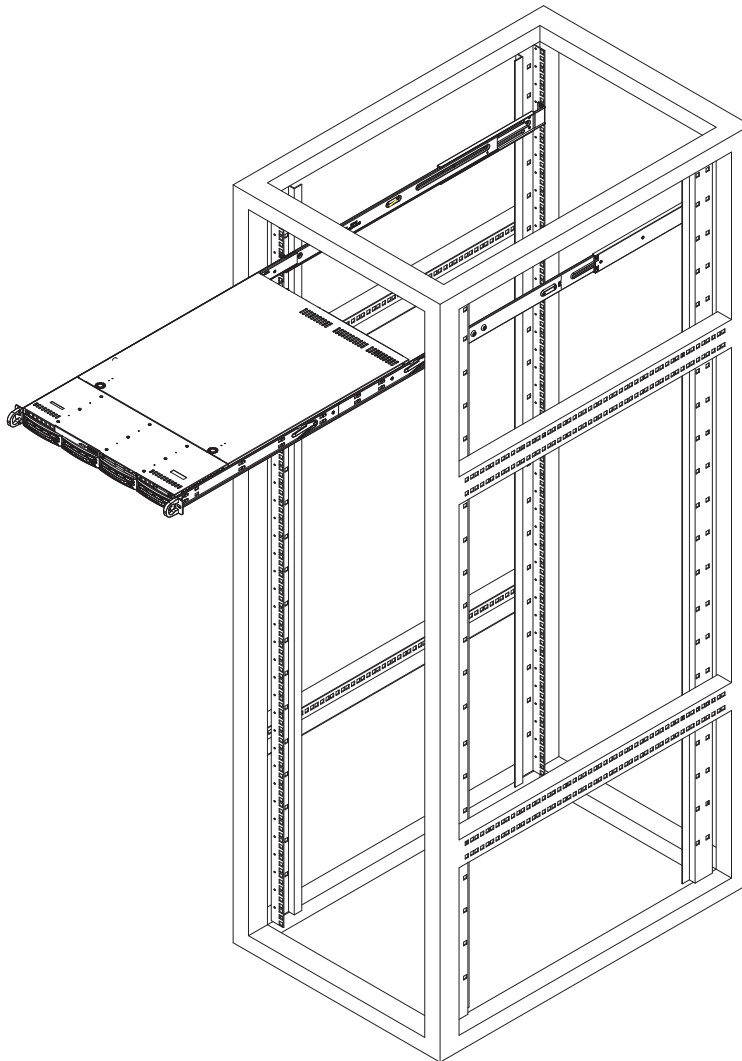

Installing the Server into a Telco Rack

To install the 6015W-UR/6015W-U/6015W-NTR/6015W-NT into a Telco type rack, use two short L-shaped brackets on either side of the chassis (four total). First, determine how far forward the server will extend out the front of the rack. Larger chassis should be positioned to balance the weight between front and back. Then attach the two front brackets to each side of the chassis, then the two rear brackets positioned with just enough space to accommodate the width of the telco rack. Finish by positioning the chassis in the rack and tightening the brackets to the rack.

Figure 2-4. Installing the Server into a Telco Rack

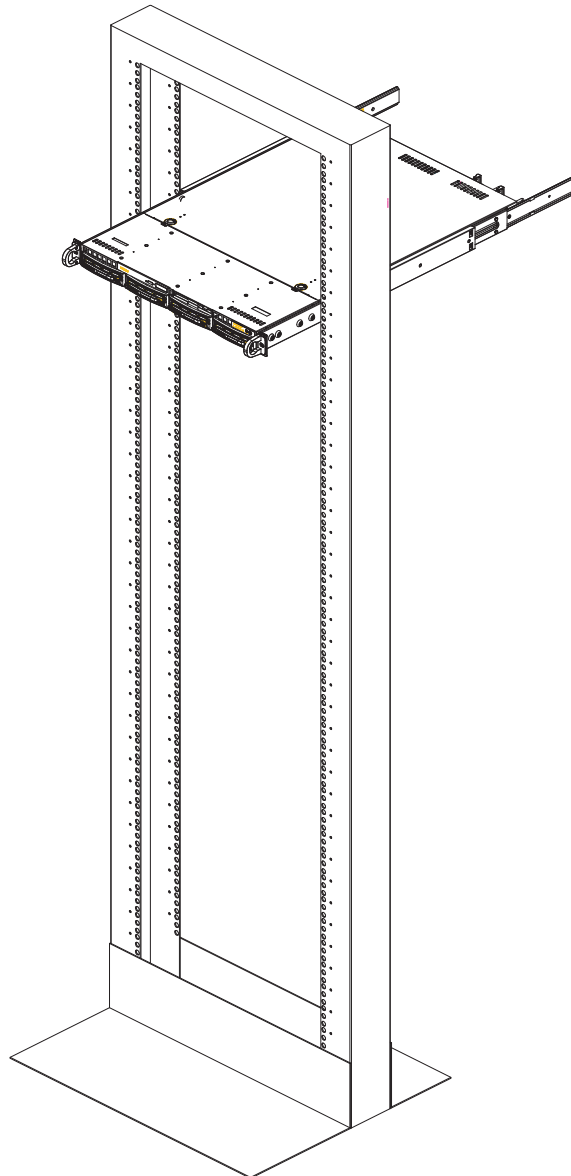

2-5 Checking the Serverboard Setup

After you install the 6015W-UR/6015W-U/6015W-NTR/6015W-NT in the rack, you will need to open the top cover to make sure the serverboard is properly installed and all the connections have been made.

Accessing the Inside of the System

1. First, grasp the two handles on either side and pull the system straight out until it locks (you will hear a "click").
2. Depress the two buttons on the top of the chassis to release the top cover (1).
3. Push the cover away from you (toward the rear of the chassis) until it stops (2). You can then lift the top cover from the chassis to gain full access to the inside of the server. See Figure 2-5.
4. To remove the system from the rack completely, depress the locking tabs in the chassis rails (push the right-side tab down and the left-side tab up) to continue to pull the system out past the locked position.

Checking the Components

1. You may have one or two processors already installed in the serverboard. Each processor needs its own heatsink. See Chapter 5 for instructions on processor and heatsink installation.
2. Your server system may have come with system memory already installed. Make sure all DIMMs are fully seated in their slots. For details on adding system memory, refer to Chapter 5.
3. If desired, you can install add-on cards to the system. See Chapter 5 for details on installing PCI add-on cards.
4. Make sure all power and data cables are properly connected and not blocking the chassis airflow. See Chapter 5 for details on cable connections.

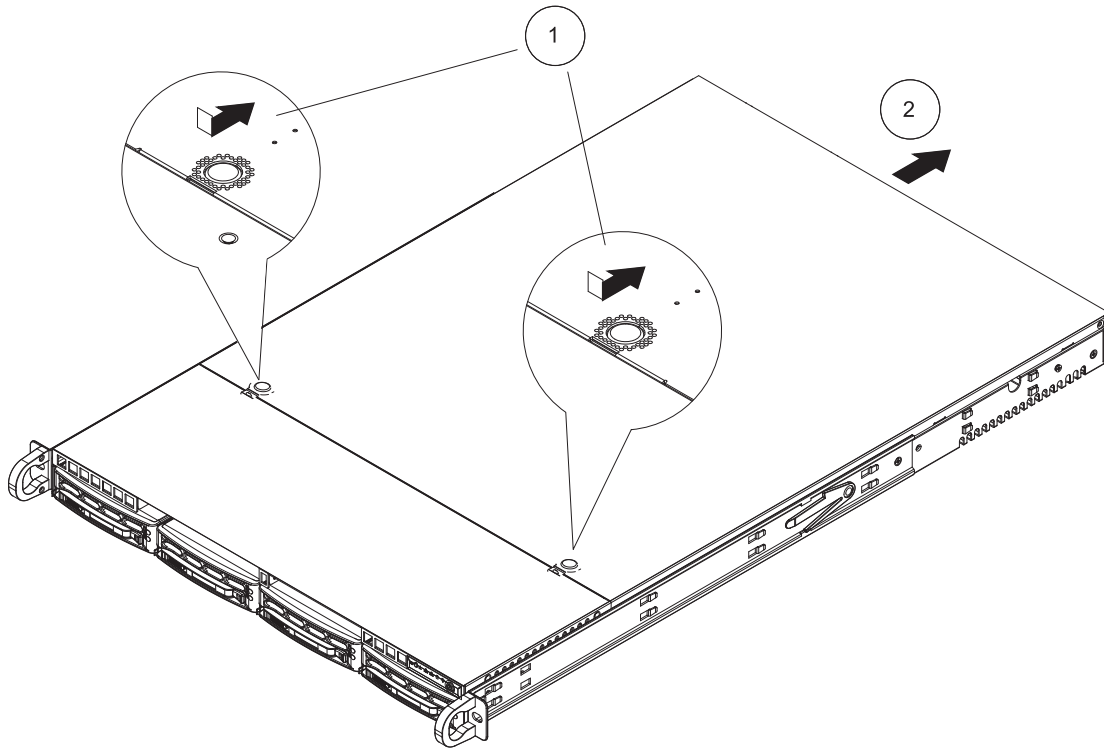

Figure 2-5. Accessing the Inside of the System

2-6 Checking the Drive Bay Setup

Next, you should check to make sure the peripheral drives and the SATA drives and SATA backplane have been properly installed and all connections have been made.

Checking the Drives

1. All drives are accessible from the front of the server. For servicing the DVD-ROM and floppy drives, you will need to remove the top chassis cover. The SATA disk drives can be installed and removed from the front of the chassis without removing the top chassis cover.
2. A slim DVD-ROM and floppy drive should be preinstalled in your server. Refer to Chapter 6 if you need to reinstall a DVD-ROM and/or floppy disk drive to the system.
3. Depending upon your system's configuration, your system may have one or more drives already installed. If you need to install SATA drives, please refer to Chapter 6.

Checking the Airflow

1. Airflow is provided by four sets of 4-cm fans (each set of fans consists of two fans that are mounted back to back). The system component layout was carefully designed to direct sufficient cooling airflow to the components that generate the most heat.
2. Note that all power and data cables have been routed in such a way that they do not block the airflow generated by the fans.

Providing Power

1. The last thing you must do is to provide input power to the system. Plug the power cords from the power supply modules into a high-quality power strip that offers protection from electrical noise and power surges.
2. It is recommended that you use an uninterruptible power supply (UPS).

Chapter 3

System Interface

3-1 Overview

There are several LEDs on the control panel as well as others on the SATA drive carriers to keep you constantly informed of the overall status of the system as well as the activity and health of specific components. There are also two buttons on the chassis control panel and an on/off switch on the power supply. This chapter explains the meanings of all LED indicators and the appropriate response you may need to take.

3-2 Control Panel Buttons

There are three push-buttons located on the front of the chassis: a reset button, a UID button and a power on/off button.

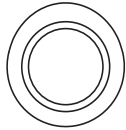

UID

Depressing the UID (unit identifier) button illuminates an LED on both the front and rear of the chassis for easy system location in large stack configurations. The LED will remain on until the button is pushed a second time. Another UID button on the rear of the chassis serves the same function.

RESET

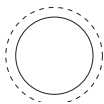

Reset

Use the reset button to reboot the system.



Power

The main power button is used to apply or remove power from the power supply to the server system. Turning off system power with this button removes the main power but keeps standby power supplied to the system.

3-3 Control Panel LEDs

The control panel located on the front of the SC815TQ-R560U/SC815TQ-560U chassis has five LEDs. These LEDs provide you with critical information related to different parts of the system. This section explains what each LED indicates when illuminated and any corrective action you may need to take.



Universal Information LED

When this LED blinks red quickly, it indicates a fan failure and when blinking red slowly a power failure. The LED will be blue when used for UID (Unit Identifier). When on continuously it indicates an overheat condition, which may be caused by cables obstructing the airflow in the system or the ambient room temperature being too warm. Check the routing of the cables and make sure all fans are present and operating normally. You should also check to make sure that the chassis covers are installed. Finally, verify that the heatsinks are installed properly (see Chapter 5). This LED will remain flashing or on as long as the indicated condition exists. See the table below for descriptions of the LED states.

Figure 3-1. Universal Information LED States

Universal Information LED States	
State	Indication
Fast Blinking Red (1x/sec)	Fan Fail
Solid Red	CPU Overheat
Slow Blinking Red (1x/4 sec)	Power Fail
Solid Blue	Local UID Button Depressed
Blinking Blue	IPMI-Activated UID

Note: deactivating the UID LED must be performed in the same way it was activated. (If the UID LED was activated via IPMI, you can only turn the LED off via IPMI and not with the UID button.)

**NIC2**

Indicates network activity on LAN2 when flashing.

**NIC1**

Indicates network activity on LAN1 when flashing.

**HDD**

Indicates IDE channel activity. On the SuperServer 6015W-UR/6015W-U/6015W-NTR/6015W-NT, this light indicates SATA and/or DVD-ROM drive activity when flashing.

**Power**

Indicates power is being supplied to the system's power supply units. This LED should normally be illuminated when the system is operating.

3-4 SATA Drive Carrier LEDs

Each Serial ATA drive carrier has two LEDs.

- **Green:** When illuminated, the green LED on the front of the SATA drive carrier indicates drive activity. A connection to the SATA backplane enables this LED to blink on and off when that particular drive is being accessed.
- **Red:** The red LED indicates two states. When blinking, it indicates the drive is rebuilding. When solid, it indicates a drive failure. If a SATA drive fails, you should be notified by your system management software. Please refer to Chapter 6 for instructions on replacing failed SATA drives.

Chapter 4

System Safety

4-1 Electrical Safety Precautions



Basic electrical safety precautions should be followed to protect yourself from harm and the SuperServer 6015W-UR/6015W-U/6015W-NTR/6015W-NT from damage:

- Be aware of the locations of the power on/off switch on the chassis as well as the room's emergency power-off switch, disconnection switch or electrical outlet. If an electrical accident occurs, you can then quickly remove power from the system.
- Do not work alone when working with high voltage components.
- Power should always be disconnected from the system when removing or installing main system components, such as the serverboard, memory modules and floppy drive. When disconnecting power, you should first power down the system with the operating system. The unit has more than one power supply cord. Disconnect both power supply cords before servicing to avoid electrical shock.
- When working around exposed electrical circuits, another person who is familiar with the power-off controls should be nearby to switch off the power if necessary.
- Use only one hand when working with powered-on electrical equipment. This is to avoid making a complete circuit, which will cause electrical shock. Use extreme caution when using metal tools, which can easily damage any electrical components or circuit boards they come into contact with.
- Do not use mats designed to decrease static electrical discharge as protection from electrical shock. Instead, use rubber mats that have been specifically designed as electrical insulators.
- The power supply power cords must include a grounding plug and must be plugged into grounded electrical outlets.

- Serverboard Battery: **CAUTION** - There is a danger of explosion if the onboard battery is installed upside down, which will reverse its polarities (see Figure 4-1). This battery must be replaced only with the same or an equivalent type recommended by the manufacturer. Dispose of used batteries according to the manufacturer's instructions.
- DVD-ROM Laser: **CAUTION** - this server may have come equipped with a DVD-ROM drive. To prevent direct exposure to the laser beam and hazardous radiation exposure, do not open the enclosure or use the unit in any unconventional way.
- Mainboard replaceable soldered-in fuses: Self-resetting PTC (Positive Temperature Coefficient) fuses on the mainboard must be replaced by trained service technicians only. The new fuse must be the same or equivalent as the one replaced. Contact technical support for details and support.

4-2 General Safety Precautions



Follow these rules to ensure general safety:

- Keep the area around the system clean and free of clutter.
- The 6015W-UR/6015W-U/6015W-NTR/6015W-NT weighs approximately 43/41 lbs (19.5/18.6 kg) when fully loaded. When lifting the system, two people at either end should lift slowly with their feet spread out to distribute the weight. Always keep your back straight and lift with your legs.
- Place the chassis top cover and any system components that have been removed away from the system or on a table so that they won't accidentally be stepped on.
- While working on the system, do not wear loose clothing such as neckties and unbuttoned shirt sleeves, which can come into contact with electrical circuits or be pulled into a cooling fan.
- Remove any jewelry or metal objects from your body, which are excellent metal conductors that can create short circuits and harm you if they come into contact with printed circuit boards or areas where power is present.

- After accessing the inside of the system, close the system back up and secure it to the rack unit after ensuring that all connections have been made.

4-3 ESD Precautions



Electrostatic discharge (ESD) is generated by two objects with different electrical charges coming into contact with each other. An electrical discharge is created to neutralize this difference, which can damage electronic components and printed circuit boards. The following measures are generally sufficient to neutralize this difference before contact is made to protect your equipment from ESD:

- Use a grounded wrist strap designed to prevent static discharge.
- Keep all components and printed circuit boards (PCBs) in their antistatic bags until ready for use.
- Touch a grounded metal object before removing the board from the antistatic bag.
- Do not let components or PCBs come into contact with your clothing, which may retain a charge even if you are wearing a wrist strap.
- Handle a board by its edges only; do not touch its components, peripheral chips, memory modules or contacts.
- When handling chips or modules, avoid touching their pins.
- Put the serverboard and peripherals back into their antistatic bags when not in use.
- For grounding purposes, make sure your computer chassis provides excellent conductivity between the power supply, the case, the mounting fasteners and the serverboard.

4-4 Operating Precautions



Care must be taken to assure that the chassis cover is in place when the 6015W-UR/6015W-U/6015W-NTR/6015W-NT is operating to assure proper cooling. Out of warranty damage to the system can occur if this practice is not strictly followed.

Figure 4-1. Installing the Onboard Battery

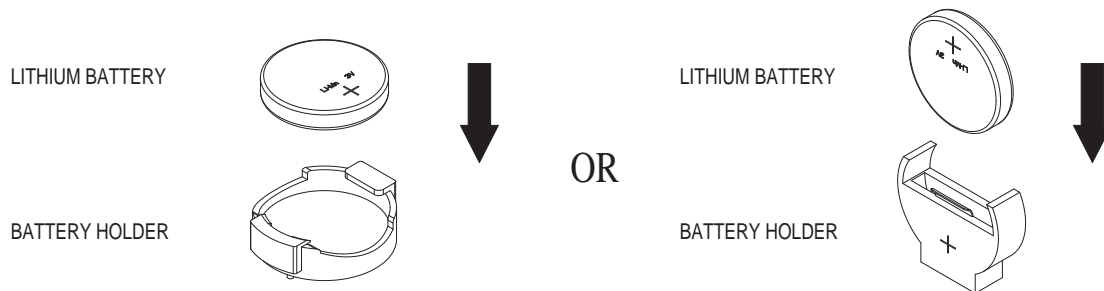

Chapter 5

Advanced Serverboard Setup

This chapter covers the steps required to install processors and heatsinks to the X7DWU serverboard, connect the data and power cables and install add-on cards. All serverboard jumpers and connections are described and a layout and quick reference chart are included in this chapter. Remember to close the chassis completely when you have finished working on the serverboard to protect and cool the system sufficiently.

5-1 Handling the Serverboard

Static electrical discharge can damage electronic components. To prevent damage to printed circuit boards, it is important to handle them very carefully (see Chapter 4). Also note that the size and weight of the serverboard can cause it to bend if handled improperly, which may result in damage. To prevent the serverboard from bending, keep one hand under the center of the board to support it when handling.

The following measures are generally sufficient to protect your equipment from static discharge.

Precautions

- Use a grounded wrist strap designed to prevent static discharge.
- Touch a grounded metal object before removing any board from its antistatic bag.
- Handle a board by its edges only; do not touch its components, peripheral chips, memory modules or gold contacts.
- When handling chips or modules, avoid touching their pins.
- Put the serverboard, add-on cards and peripherals back into their antistatic bags when not in use.

Unpacking

The serverboard is shipped in antistatic packaging to avoid static damage. When unpacking the board, make sure the person handling it is static protected.

5-2 Processor and Heatsink Installation



When handling the processor, avoid placing direct pressure on the label area of the fan. Also, do not place the serverboard on a conductive surface, which can damage the BIOS battery and prevent the system from booting up.

IMPORTANT! Always connect the power cord last and remove it first before adding, removing or changing any hardware components. Make sure that you install the processor into the CPU socket *before* you install the heatsink and fan. The X7DWU can support either one or two Xeon processors. If installing one processor only, install it into CPU socket #1.

Notes:

1. Intel's boxed Xeon CPU package contains a CPU fan and heatsink assembly. If you buy a CPU separately, make sure that you use only Intel-certified multi-directional heatsinks and fans.
2. When purchasing a Xeon CPU or when receiving a serverboard with a CPU pre-installed, make sure that the CPU plastic cap is in place and none of the CPU pins are bent; otherwise, contact the retailer immediately.

Installing the Processor

1. A black PnP cap is attached to the load plate to protect the CPU socket. Press the load lever down and away from the retention clasp to release the load plate from its locked position.
2. Gently lift the load lever to open the load plate.

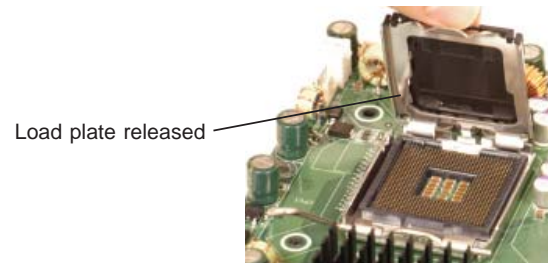
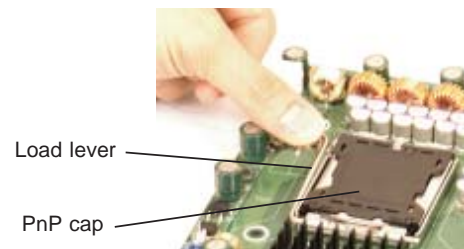

3. Use your thumb and index finger to hold the CPU at opposite sides.
4. Align pin1 of the CPU (the corner marked with a triangle) with the notched corner of the CPU socket.
5. Find the corner of the CPU that has a semi-circle cutout below a gold dot (CPU key). This corner should be aligned with the cutout on the socket (socket key).
6. Once aligned, carefully lower the CPU straight down into the socket. Do not drop the CPU on the socket, do not move the CPU horizontally or vertically and do not rub the CPU against any surface or any of the contacts, which may damage the CPU and/or its contacts.
7. With the CPU in the socket, inspect the four corners of the CPU to make sure that it is properly installed.
8. Use your thumb to gently push the load lever down until it snaps into the retention clasp.
9. If the CPU is properly installed into the socket, the PnP cap will be automatically released from the load plate when the lever locks. Repeat steps to install a second CPU if desired.

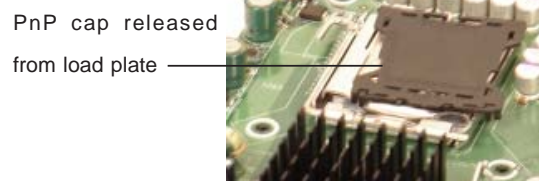
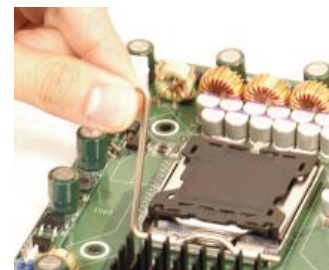
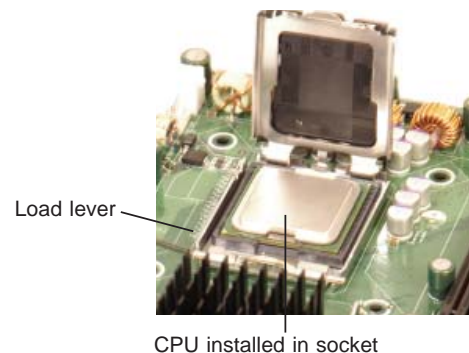
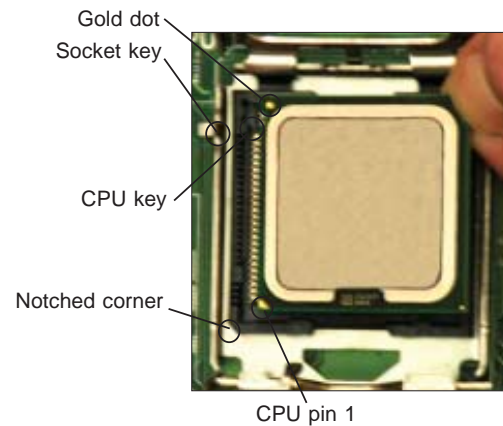

Installing the Heatsink

1. Do not apply any thermal grease to the heatsink or the CPU die; the required amount has already been applied.
2. Place the heatsink on top of the CPU so that the four mounting holes are aligned with those on the (pre-installed) heatsink retention mechanism.
3. Screw in two diagonal screws (i.e. the #1 and the #2 screws) until just snug. Do not fully tighten the screws or you may damage the CPU.)
4. Add the two remaining screws then finish the installation by fully tightening all four screws.

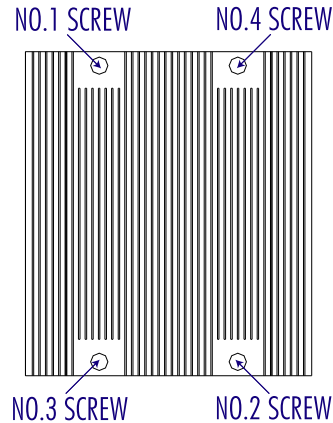

Removing the Heatsink



Warning! We do not recommend that the CPU or the heatsink be removed. However, if you do need to uninstall the heatsink, please follow the instructions below to prevent damage to the CPU or the CPU socket.

1. Unscrew and remove the heatsink screws from the serverboard in the sequence as show in the picture above.
2. Hold the heatsink and gently wriggle the heatsink to loosen it from the CPU. (Do not use excessive force when wriggling the heatsink!!)
3. Once the heatsink is loose, remove it from the CPU.
4. Clean the surface of the CPU and the heatsink to get rid of the old thermal grease. Reapply the proper amount of thermal grease on the surface before you re-install the heatsink.

5-3 Connecting Cables

Now that the processors are installed, the next step is to connect the cables to the serverboard. These include the data (ribbon) cables for the peripherals and control panel and the power cables.

Connecting Data Cables

The cables used to transfer data from the peripheral devices have been carefully routed in preconfigured systems to prevent them from blocking the flow of cooling air that moves through the system from front to back. If you need to disconnect any of these cables, you should take care to reroute them as they were originally after reconnecting them (make sure the red wires connect to the pin 1 locations). If you are configuring the system, keep the airflow in mind when routing the cables. The following data cables (with their serverboard connector locations noted) should be connected.

See the serverboard layout diagram in this chapter for connector locations.

- DVD-ROM Drive cable (IDE#1)
- Control Panel cable (JF1, see next page)
- SATA cables, 6015W-NTR/6015W-NT only (I-SATA0 ~ I-SATA3)
- SGPIO cable, 6015W-NTR/6015W-NT only (T-SGPIO1 to SATA backplane)

Connecting Power Cables

The X7DWU has a 20-pin primary power supply connector designated "JPW1" for connection to the ATX power supply. Connect the appropriate connector from the power supply to JPW1 to supply power to the serverboard. See the Connector Definitions section in this chapter for power connector pin definitions.

In addition, your power supply must be connected to the 4-pin Auxiliary ATX Power connection at JPW2 and the 8-pin Processor Power connector at JPW3.

Connecting the Control Panel

JF1 contains header pins for various front control panel connectors. See Figure 5-1 for the pin locations of the various front control panel buttons and LED indicators. Please note that even and odd numbered pins are on opposite sides of each header.

All JF1 wires have been bundled into single keyed ribbon cable to simplify their connection. The red wire in the ribbon cable plugs into pin 1 of JF1. Connect the other end of the cable to the Control Panel printed circuit board, located just behind the system status LEDs in the chassis.

See the Connector Definitions section in this chapter for details and pin descriptions of JF1.

Figure 5-1. Front Control Panel Header Pins (JF1)

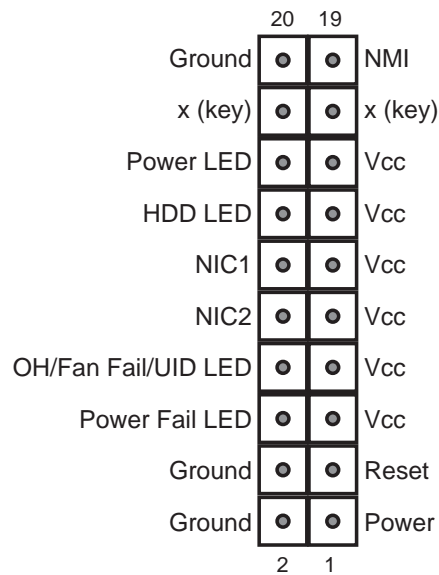

5-4 I/O Ports

The I/O ports are color coded in conformance with the PC 99 specification. See Figure 5-2 below for the colors and locations of the various I/O ports.

Figure 5-2. Rear Panel I/O Ports

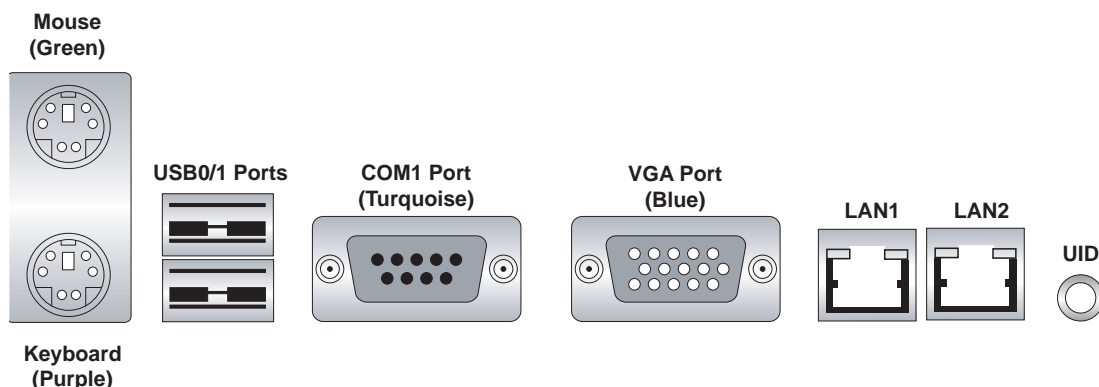

5-5 Installing Memory

Note: Check the Supermicro web site for recommended memory modules.

CAUTION

Exercise extreme care when installing or removing DIMM modules to prevent any possible damage. Also note that the memory is interleaved to improve performance (see step 1).

Installing DIMMs

1. Insert the desired number of DIMMs into the memory slots, starting with slot DIMM#1A and DIMM#2A. The memory scheme is interleaved so you must install two modules at a time. See the memory configuration chart below.
2. Insert each DIMM module vertically into its slot. Pay attention to the notch along the bottom of the module to prevent inserting the DIMM module incorrectly. See Figure 5-5.
3. Gently press down on the DIMM module until it snaps into place in the slot. Repeat for all modules (see step 1 above).

Memory Support

The X7DWU supports up to 64 GB of ECC FBD (Fully Buffered DIMM) DDR2-800/667/533 SDRAM. Both 1.5V and 1.8V DIMMs are supported. Interleaved memory requires modules of the same size and speed to be installed in pairs. You should not mix DIMMs of different sizes and speeds.

Optimized DIMM Population Configurations													
Number of DIMMs	Branch 0						Branch 1						
	Bank 1 (Channel 0)			Bank 2 (Channel 1)			Bank 3 (Channel 2)			Bank 4 (Channel 3)			
2 DIMMs	1A	---		2A	---		---	---		---	---		
4 DIMMs	1A	---		2A	---		3A	---		4A	---		
6 DIMMs	1A	1B		2A	2B		3A	---		4A	---		
8 DIMMs	1A	1B		2A	2B		3A	3B		4A	4B		

Notes: i. “---“ indicates a DIMM slot not to be populated. ii. You must use memory modules of the same speed and type in all populated slots. iii. Interleaved memory is supported when pairs of DIMM modules are installed. For best performance, please install memory modules in both Branch 0 and Branch 1.

Notes: Due to OS limitations, some operating systems may not show more than 4 GB of memory. Due to memory allocation to system devices, memory remaining available for operational use will be reduced when 4 GB of RAM is used. The reduction in memory availability is disproportional. (Refer to the Memory Availability Table below for details.)

Possible System Memory Allocation & Availability		
System Device	Size	Physical Memory Remaining (4 GB Total System Memory)
Firmware Hub flash memory (System BIOS)	1 MB	3.99
Local APIC	4 KB	3.99
Area Reserved for the chipset	2 MB	3.99
I/O APIC (4 Kbytes)	4 KB	3.99
PCI Enumeration Area 1	256 MB	3.76
PCI Express (256 MB)	256 MB	3.51
PCI Enumeration Area 2 (if needed) -Aligned on 256-MB boundary-	512 MB	3.01
VGA Memory	16 MB	2.85
TSEG	1 MB	2.84
Memory available to System BIOS & OS applications		2.84

Figure 5-3. Installing DIMM into Slot

To Install: Insert module vertically and press down until it snaps into place. Pay attention to the bottom notch.

To Remove: Use your thumbs to gently push each release tab outward to free the DIMM from the slot.

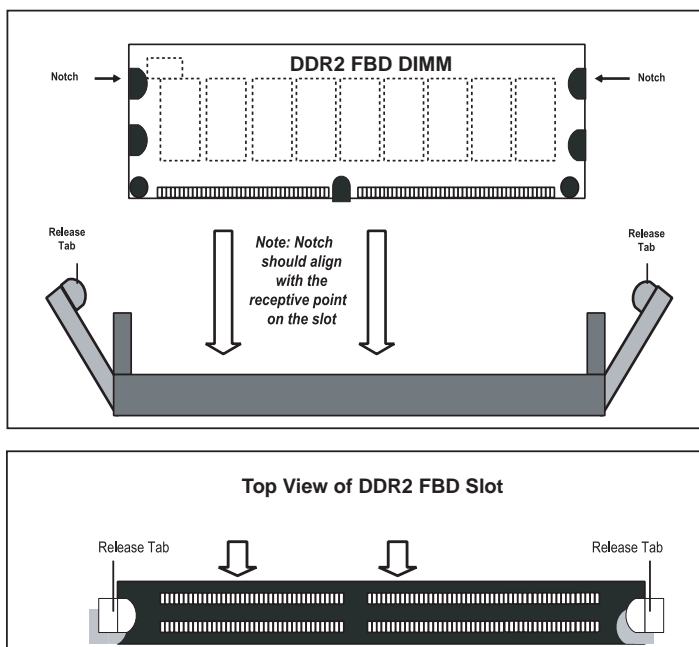

5-6 Adding PCI Cards

PCI Expansion Slots

Two riser cards are used to support add-on cards to the system. The SC815TQ-R650U/SC815TQ-560U chassis can accommodate one standard size (full height full length) and one low profile PCI expansion card. When viewed from the chassis front, the standard size card installs to the left and the low-profile card installs to the right side.

PCI cards are installed into riser cards that have been pre-installed to the system. An additional two riser cards are included to support PCI-E add-on cards. See configuration list below.

PCI Card Installation

Before installing a PCI add-on card, make sure you install it into the correct riser card. Begin by releasing the locking tab that corresponds to the slot you wish to populate. Insert the expansion card into the correct riser card, pushing down with your thumbs evenly on both sides of the card.

PCI Slot/Card Configurations

6015W-UR/6015W-U

Left Side Riser Card

CSE-R1UU-UE8 (pre-installed)

Expansion card supported

1x UIO card and 1x PCI-E x8 card

Right Side Riser Card

RSC-R1UU-E8R (pre-installed)

Expansion card supported

1x PCI-Express x8 card
(maximum length of 5.5")

6015W-NTR/6015W-NT

Left Side Riser Card

CSE-R1UU-2E8 (pre-installed)

Expansion card supported

2x PCI-E x8 cards

Right Side Riser Card

RSC-R1UU-E8R (pre-installed)

Expansion card supported

1x PCI-Express x8 card
(maximum length of 5.5")

5-7 Serverboard Details

Figure 5-4. SUPER X7DWU Layout
(not drawn to scale)

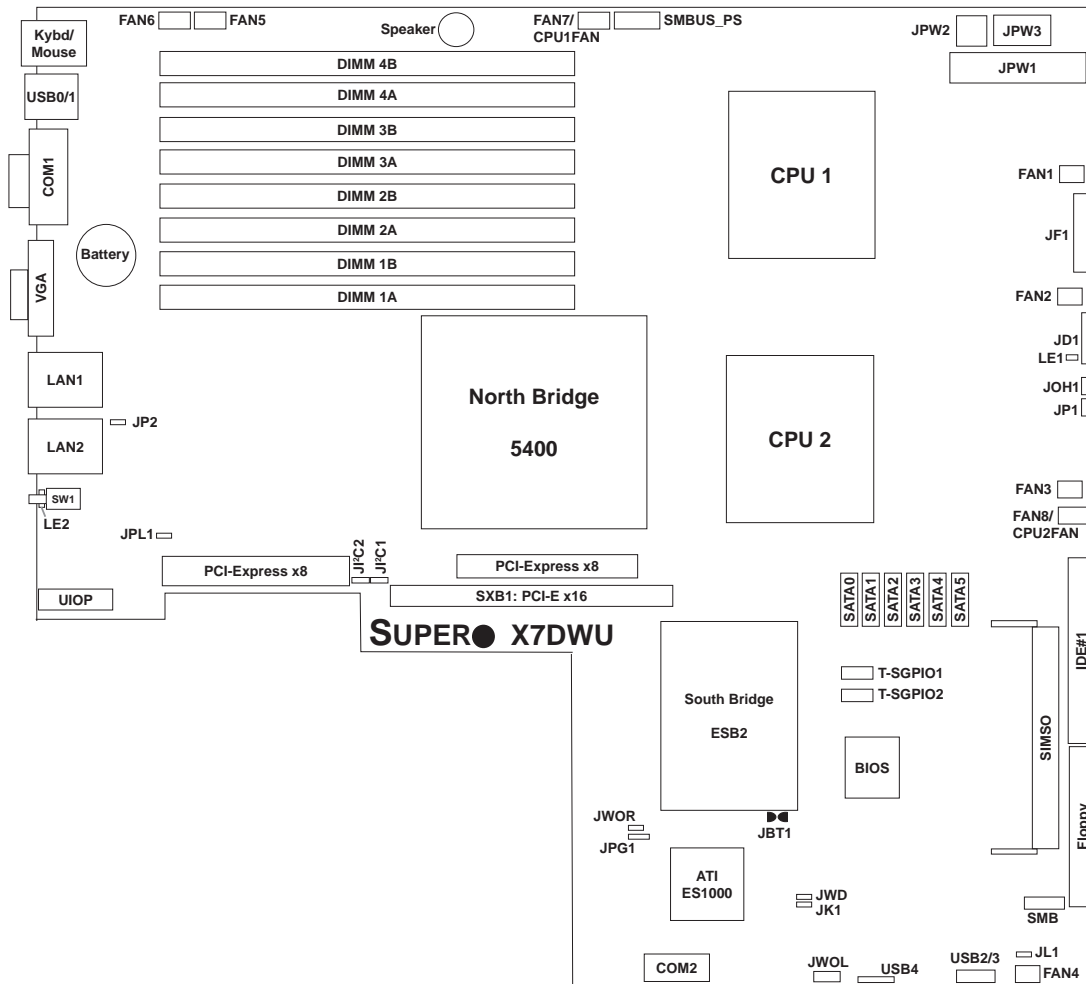

Notes:

Jumpers not noted are for test purposes only.

X7DWU Quick Reference

Jumper	Description	Default Setting
JBT1	CMOS Clear	(See Section 5-9)
J ² C1/J ² C2	I2C En/Disable SMB to PCI Slots	Open (Disabled)
JP1	Power Force On	Normal (Off)
JP2	Memory Voltage Select	Auto (Pins 1-2)
JPG1	VGA Enable/Disable	Pins 1-2 (Enabled)
JPL1	LAN1/2 Enable/Disable	Pins 1-2 (Enabled)
JWD	Watch Dog	Pins 1-2 (Reset)

Connector	Description
COM1/COM2	COM1/COM2 Serial Port/Header
FAN 1-8	Chassis/CPU Fan Headers
Floppy	Floppy Disk Drive Connector
IDE#1	IDE HDD Connector
JD1	Speaker Header
JF1	Front Panel Connector
JK1	Chassis Intrusion Header
JOH1	Overheat Warning Header
JPW1	20-pin Main ATX Power Connector
JPW2	4-pin Auxilliary Power Connector
JPW3	8-pin Processor Power Connector
JWOL	Wake-On-LAN Header
JWOR	Wake-On-Ring Header
LAN1/2	Gigabit Ethernet (RJ45) Ports
SATA0 ~ SATA5	SATA Ports
SIMSO	SIMSO IPMI 2.0 Socket
SMBUS_PS	Power Supply SMBus Connector
T-SGPIO-1/T-SGPIO-2	Serial General Purpose Input/Output Headers
USB0/1	Universal Serial Bus (USB) Ports
USB2/3/4	Onboard Universal Serial Bus (USB) Headers

Other	Description
LE1	Power On LED
LE2	Rear UID LED
SW1	UID (Unit Identifier) Switch

5-8 Connector Definitions

ATX Power Connector

The primary ATX power supply connector meets the SSI (Superset ATX) 20-pin specification. Make sure that the orientation of the connector is correct. See the table on the right for pin definitions.

ATX Power 20-pin Connector Pin Definitions (JPW1)			
Pin#	Definition	Pin #	Definition
11	+3.3V	1	+3.3V
12	-12V	2	+3.3V
13	COM	3	COM
14	PS_ON	4	+5V
15	COM	5	COM
16	COM	6	+5V
17	COM	7	COM
18	Res (NC)	8	PWR_OK
19	+5V	9	5VSB
20	+5V	10	+12V

Auxiliary Power Connector

In addition to the Primary ATX power connector (above), the Auxiliary 4-pin connector at JPW2 must also be connected to your power supply. See the table on the right for pin definitions.

Auxiliary Power Pin Definitions (JPW2)	
Pins	Definition
1 & 2	Ground
3 & 4	+12V

Processor Power Connector

JPW3 must also be connected to the power supply to provide power for the processor(s). See the table on the right for pin definitions.

Processor Power Pin Definitions (JPW3)	
Pins	Definition
1 through 4	Ground
5 through 8	+12V

NMI Button

The non-maskable interrupt button header is located on pins 19 and 20 of JF1. Refer to the table on the right for pin definitions.

NMI Button Pin Definitions (JF1)	
Pin#	Definition
19	Control
20	Ground

Power LED

The Power LED connection is located on pins 15 and 16 of JF1. Refer to the table on the right for pin definitions.

Power LED Pin Definitions (JF1)	
Pin#	Definition
15	Vcc
16	Control

HDD LED

The HDD (IDE Hard Disk Drive) LED connection is located on pins 13 and 14 of JF1. Attach the IDE hard drive LED cable to display disk activity. Refer to the table on the right for pin definitions.

HDD LED Pin Definitions (JF1)	
Pin#	Definition
13	Vcc
14	HD Active

NIC1 LED

The NIC1 (Network Interface Controller) LED connection is located on pins 11 and 12 of JF1. Attach the NIC1 LED cable to display network activity. Refer to the table on the right for pin definitions.

NIC1 LED Pin Definitions (JF1)	
Pin#	Definition
11	Vcc
12	Ground

NIC2 LED

The NIC2 (Network Interface Controller) LED connection is located on pins 9 and 10 of JF1. Attach the NIC2 LED cable to display network activity. Refer to the table on the right for pin definitions.

NIC2 LED Pin Definitions (JF1)	
Pin#	Definition
9	Vcc
10	Ground

Universal Information LED

Connect an LED to pins 7 and 8 of JF1 to provide advanced warning of chassis overheating or fan failure. These pins also work with the front UID indicator, which will activate as either a solid or flashing blue LED depending on whether the LED was activated via IPMI or the UID button. Refer to the tables on the right for pin definitions and status indicators.

Universal Info. LED Pin Definitions (JF1)	
Pin#	Definition
7	Vcc
8	Control

Red LED Indications	
State	Indication
Solid	Overheat
Blinking (fast)	Fan Fail
Blinking (slow)	Power Fail

Blue LED Indications	
State	Indication
Solid	UID (via Button)
Blinking	UID (via IPMI)

Power Fail LED

The Power Fail LED connection is located on pins 5 and 6 of JF1. Refer to the table on the right for pin definitions.

Power Fail LED Pin Definitions (JF1)	
Pin#	Definition
5	Vcc
6	Ground

Reset Button

The Reset Button connection is located on pins 3 and 4 of JF1. Attach it to the hardware reset switch on the computer case. Refer to the table on the right for pin definitions.

Reset Button Pin Definitions (JF1)	
Pin#	Definition
3	Reset
4	Ground

Power Button

The Power Button connection is located on pins 1 and 2 of JF1. Momentarily contacting both pins will power on/off the system. This button can also be configured to function as a suspend button (see the Power Button Mode setting in BIOS). To turn off the power when set to suspend mode, depress the button for at least 4 seconds. Refer to the table on the right for pin definitions.

Power Button Pin Definitions (JF1)	
Pin#	Definition
1	PW_ON
2	Ground

Universal Serial Bus (USB0/1)

Two Universal Serial Bus ports are located on the I/O backplane. USB0 is the bottom connector and USB1 is the top connector. See the table on the right for pin definitions.

Universal Serial Bus Pin Definitions (USB0/1)			
USB0		USB1	
Pin #	Definition	Pin #	Definition
1	+5V	1	+5V
2	PO-	2	PO-
3	PO+	3	PO+
4	Ground	4	Ground
5	N/A	5	Key

Universal Serial Bus Headers

Three additional USB headers (USB2/USB3 and USB4) are included on the serverboard. These may be used for front side access. A USB cable (not included) is needed for the connection. See the table on the right for pin definitions.

Universal Serial Bus Headers Pin Definitions (USB2/3, USB4)			
USB2		USB3, USB4	
Pin #	Definition	Pin #	Definition
1	+5V	1	+5V
2	PO-	2	PO-
3	PO+	3	PO+
4	Ground	4	Ground
5	Key	5	NC

Serial Ports

The COM1 serial port is located on the IO backplane. COM2 is a header on the serverboard (see serverboard layout for location). See the table on the right for pin definitions.

Serial Port Pin Definitions (COM1, COM2)			
Pin #	Definition	Pin #	Definition
1	DCD	6	DSR
2	RXD	7	RTS
3	TXD	8	CTS
4	DTR	9	RI
5	Ground	10	NC

Note: Pin 10 is included on the header but not on the port. NC indicates no connection.

Fan Headers

The X7DWU has eight headers, designated Fan1 through Fan8. FAN7 and FAN8 are for the CPU heatsinks. These 4-pin fan headers are for Pulse Width Modulated (PWM) fans and their speed is controlled via Thermal Management with a BIOS setting. See the tables on the right for pin definitions.

4-pin Fan Header Pin Definitions (FAN1-8)	
Pin#	Definition
1	Ground (Black)
2	+12V (Red)
3	Tachometer
4	PWM Control

Power LED/Speaker

On the JD1 header, pins 1-3 are for a power LED, pins 4-7 are for the speaker. See the table on the right for speaker pin definitions.

Note: The speaker connector pins are for use with an external speaker. If you wish to use the onboard speaker, you should close pins 6-7 with a jumper.

Speaker Connector Pin Definitions (JD1)		
Pin #	Function	Definition
4	+	Speaker data (red wire)
5	Key	No connection
6		Key
7		Speaker data

ATX PS/2 Keyboard and PS/2 Mouse Ports

The ATX PS/2 keyboard and the PS/2 mouse ports are located beside the USB ports. See the table on the right for pin definitions.

PS/2 Keyboard and Mouse Ports Pin Definitions	
Pin#	Definition
1	Data
2	NC
3	Ground
4	VCC
5	Clock
6	NC

Overheat LED

Connect an LED to the JOH1 header to provide warning of a chassis overheating condition. See the table on the right for pin definitions.

Overheat LED Pin Definitions (JOH1)	
Pin#	Definition
1	+5V
2	OH Active

Wake-On-LAN

The Wake-On-LAN header is designated JWOL. See the table on the right for pin definitions. You must enable the LAN Wake-Up setting in BIOS to use this feature. You must also have a LAN card with a Wake-on-LAN connector and cable.

Wake-On-LAN Pin Definitions (JWOL)	
Pin#	Definition
1	+5V Standby
2	Ground
3	Wake-up

Wake-On-Ring

The Wake-On-Ring header is designated JWOR. This function allows your computer to receive and "wake-up" by an incoming call to the modem when in suspend state. See the table on the right for pin definitions. You must have a WOR card and cable to use this feature.

Wake-On-Ring Pin Definitions (JWOR)	
Pin#	Definition
1	Ground (Black)
2	Wake-up

SMB

The System Management Bus header (for the PCI bus) is designated SMB. Connect the appropriate cable here to utilize SMB on your system. See the table on the right for pin definitions.

SMB Header Pin Definitions (SMB)	
Pin#	Definition
1	Data
2	Ground
3	Clock
4	No Connection

SMBUS_PS

This header is for I²C, which may be used to monitor the status of the power supply. See the table on the right for pin definitions.

SMBUS_PS (I ² C) Pin Definitions	
Pin#	Definition
1	Clock
2	SMB Data
3	N/A
4	N/A
5	N/A

LAN1/2 (Ethernet Ports)

Two Ethernet ports (designated LAN1 and LAN2) are located beside the VGA port on the I/O backplane. These ports accept RJ45 type cables.



SGPIO

The two headers labeled T-SGPIO1 and T-SGPIO2 are for SGPIO (Serial General Purpose Input/Output). SGPIO provides a bus between the SATA controller and the SATA drive backplane to provide SATA enclosure management functions. Connect the appropriate cables from the backplane to the SGPIO1 and SGPIO2 headers to utilize SATA management functions on your system.

SGPIO Header Pin Definitions (T-SGPIO1, T-SGPIO2)			
Pin#	Definition	Pin #	Definition
1	NC	2	NC
3	Ground	4	Data
5	Load	6	Ground
7	NC	8	NC

Note: NC indicates no connection.

5-9 Jumper Settings

Explanation of Jumpers

To modify the operation of the serverboard, jumpers can be used to choose between optional settings. Jumpers create shorts between two pins to change the function of the connector. Pin 1 is identified with a square solder pad on the printed circuit board. See the diagram at right for an example of jumping pins 1 and 2. Refer to the serverboard layout page for jumper locations.

Note: On two-pin jumpers, "Closed" means the jumper is on and "Open" means the jumper is off the pins.

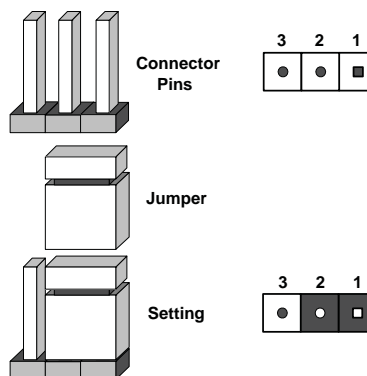

CMOS Clear

JBT1 is used to clear CMOS and will also clear any passwords. Instead of pins, this jumper consists of contact pads to prevent accidentally clearing the contents of CMOS.

To Clear CMOS

1. First power down the system and unplug the power cord(s).
2. With the power disconnected, short the CMOS pads with a metal object such as a small screwdriver.
3. Remove the screwdriver (or shorting device).
4. Reconnect the power cord(s) and power on the system.

Note: *Do not use the PW ON connector to clear CMOS.*

VGA Enable/Disable

JPG1 allows you to enable or disable the VGA port. The default position is on pins 1 and 2 to enable VGA. See the table on the right for jumper settings.

VGA Enable/Disable Jumper Settings (JPG1)	
Jumper Setting	Definition
Pins 1-2	Enabled
Pins 2-3	Disabled

Power Force On

Jumper JP1 allows you to enable or disable the Power Force-On function. If enabled, the power will always stay on automatically. If disabled (the default setting), the user must press the power button to power on the system.

Power Force-On Jumper Settings (JP1)	
Jumper Setting	Definition
Open	Disabled
Closed	Force Pwr On

LAN Enable/Disable

Change the setting of jumper JPL1 to enable or disable the onboard Ethernet (RJ45) ports LAN1 and LAN2. See the table on the right for jumper settings. The default setting is enabled

LAN Enable/Disable Jumper Settings (JPL1)	
Jumper Setting	Definition
Pins 1-2	Enabled
Pins 2-3	Disabled

Memory Voltage Select

JP2 is used to specify the voltage level for the onboard memory (SDRAM). The default setting is on pins 1-2, which lets the BIOS automatically determine the correct setting. See the table on the right for jumper settings.

Memory Voltage Select Jumper Settings (JP2)	
Jumper Setting	Definition
Pins 1-2	Auto
Pins 2-3	1.5V
Open	1.8V

Watch Dog Enable/Disable

JWD controls the Watch Dog function. Watch Dog is a system monitor that can reboot the system when a software application is “hung up”. Pins 1-2 will cause WD to reset the system if an application is hung up. Pins 2-3 will generate a non-maskable interrupt signal for the application that is hung up. See the table on the right for jumper settings. Watch Dog must also be enabled in BIOS.

Watch Dog Jumper Settings (JWD)	
Jumper Setting	Definition
Pins 1-2	Reset
Pins 2-3	NMI
Open	Disabled

Note: When enabled, the user needs to write their own application software to disable the Watch Dog Timer.

I²C Enable/Disable

JI²C1 and JI²C2 are used to enable or disable I²C bus on the serverboard. See the table on the right for jumper settings. Both jumpers must be set the same for the setting to function correctly (one jumper enables the clock and the other enables the data). The default setting is disabled.

I ² C Bus Enable/Disable Jumper Settings (JI ² C1, JI ² C2)	
Jumper Setting	Definition
Pins 1-2	Enabled
Pins 2-3	Disabled

5-10 Onboard Indicators

LAN1/LAN2 LEDs

The Ethernet ports (located beside the VGA port) have two LEDs. On each Gigabit LAN port, one LED indicates activity when blinking while the other LED may be green, amber or off to indicate the speed of the connection. See the table on the right for the functions associated with the connection speed LED.

LAN LED Connection Speed Indicator	
LED Color	Definition
Off	10 MHz
Green	100 MHz
Amber	1 GHz

LE1

The LE1 LED located near JD1 is the power LED. LE1 illuminates when the serverboard is powered up and operating.

LE2

The LE2 LED located under SW1 is the UID indicator LED. LE2 illuminates when UID is initiated either by the UID button or via IPMI. If initiated a second time, LE2 will turn off.

When the LED blinks blue it means the signal was initiated via IPMI. If blue continuously it means the UID button initiated it.

5-11 Floppy, IDE and SATA Drive Connections

Note the following when connecting the floppy and hard disk drive cables:

- The floppy disk drive cable has seven twisted wires.
- A red mark on a wire typically designates the location of pin 1.
- A single floppy disk drive ribbon cable has 34 wires and two connectors to provide for two floppy disk drives. The connector with twisted wires always connects to drive A, and the connector that does not have twisted wires always connects to drive B.

Floppy Connector

The floppy connector is designated Floppy. See the table below for pin definitions.

Floppy Drive Connector Pin Definitions (Floppy)			
Pin#	Definition	Pin #	Definition
1	Ground	2	FDHDIN
3	Ground	4	Reserved
5	Key	6	FDEDIN
7	Ground	8	Index
9	Ground	10	Motor Enable
11	Ground	12	Drive Select B
13	Ground	14	Drive Select B
15	Ground	16	Motor Enable
17	Ground	18	DIR
19	Ground	20	STEP
21	Ground	22	Write Data
23	Ground	24	Write Gate
25	Ground	26	Track 00
27	Ground	28	Write Protect
29	Ground	30	Read Data
31	Ground	32	Side 1 Select
33	Ground	34	Diskette

IDE Connector

There are no jumpers to configure the onboard IDE#1 connector. See the table on the right for pin definitions.

IDE Drive Connector Pin Definitions (IDE#1)			
Pin#	Definition	Pin #	Definition
1	Reset IDE	2	Ground
3	Host Data 7	4	Host Data 8
5	Host Data 6	6	Host Data 9
7	Host Data 5	8	Host Data 10
9	Host Data 4	10	Host Data 11
11	Host Data 3	12	Host Data 12
13	Host Data 2	14	Host Data 13
15	Host Data 1	16	Host Data 14
17	Host Data 0	18	Host Data 15
19	Ground	20	Key
21	DRQ3	22	Ground
23	I/O Write	24	Ground
25	I/O Read	26	Ground
27	IOCHRDY	28	BALE
29	DACK3	30	Ground
31	IRQ14	32	IOCS16
33	Addr1	34	Ground
35	Addr0	36	Addr2
37	Chip Select 0	38	Chip Select 1
39	Activity	40	Ground

SATA Ports

See the table on the right for pin definitions for the onboard SATA ports.

SATA Port Pin Definitions (SATA0 ~ SATA5)	
Pin #	Definition
1	Ground
2	TXP
3	TXN
4	Ground
5	RXN
6	RXP
7	Ground

5-12 Installing Drivers

After all the hardware and operating system have been installed, you need to install certain drivers. The necessary drivers are all included on the Supermicro CD that came packaged with your serverboard. After inserting this CD into your CD-ROM drive, the display shown in Figure 5-4 should appear. (If this display does not appear, click on the My Computer icon and then on the icon representing your CD-ROM drive. Finally, double click on the S "Setup" icon.)

Figure 5-4. Driver Installation Display Screen

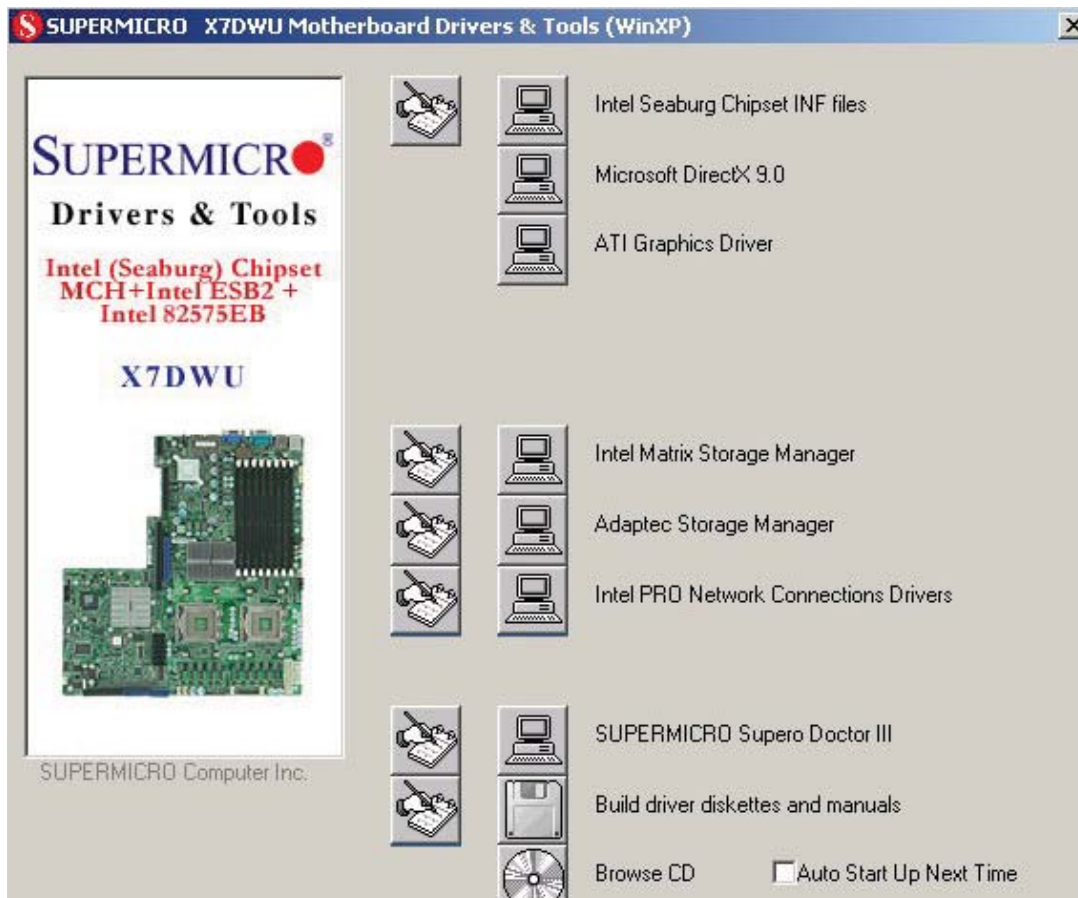

Click the icons showing a hand writing on paper to view the readme files for each item. Click the tabs to the right of these *in order from top to bottom* to install each item one at a time. **After installing each item, you must reboot the system before moving on to the next item on the list.** You should install everything here except for the SUPER Doctor utility, which is optional. The bottom icon with a CD on it allows you to view the entire contents of the CD.

Chapter 6

Advanced Chassis Setup

This chapter covers the steps required to install components and perform maintenance on the SC815TQ-R650U/SC815TQ-560U chassis. For component installation, follow the steps in the order given to eliminate the most common problems encountered. If some steps are unnecessary, skip ahead to the next step.

Tools Required: The only tool you will need to install components and perform maintenance is a Philips screwdriver.

6-1 Static-Sensitive Devices

Electrostatic discharge (ESD) can damage electronic components. To prevent damage to any printed circuit boards (PCBs), it is important to handle them very carefully. The following measures are generally sufficient to protect your equipment from ESD damage.

Precautions

- Use a grounded wrist strap designed to prevent static discharge.
- Touch a grounded metal object before removing any board from its antistatic bag.
- Handle a board by its edges only; do not touch its components, peripheral chips, memory modules or gold contacts.
- When handling chips or modules, avoid touching their pins.
- Put the serverboard, add-on cards and peripherals back into their antistatic bags when not in use.
- For grounding purposes, make sure your computer chassis provides excellent conductivity between the power supply, the case, the mounting fasteners and the serverboard.

Figure 6-1. Chassis: Front and Rear Views

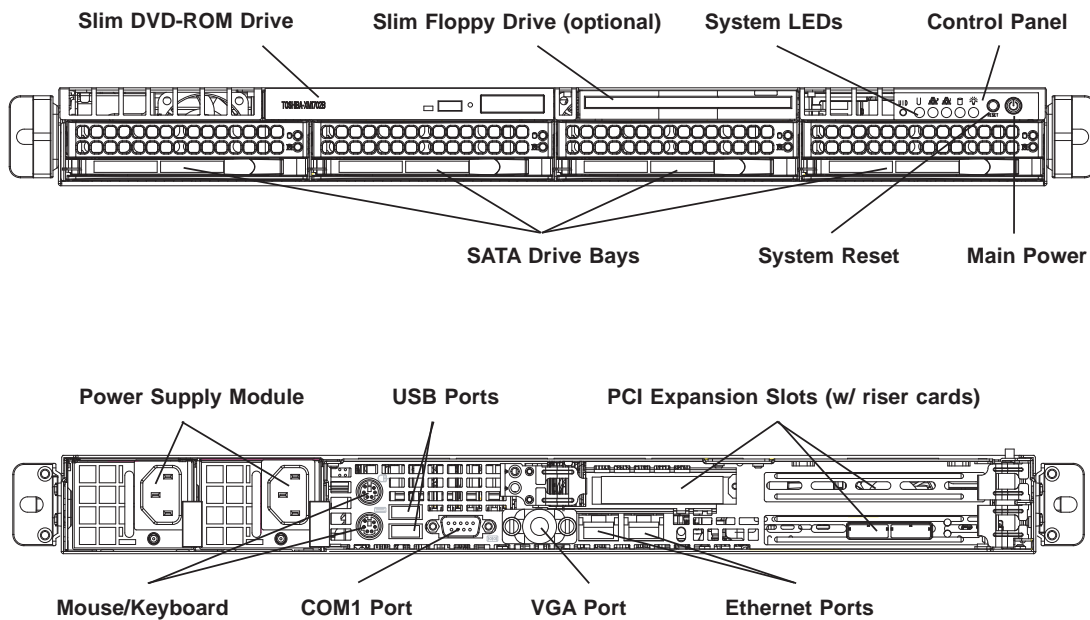

Note: the SC815TQ-560U chassis (6015W-U/6015W-NT) has only a single power supply module.

6-2 Control Panel

The control panel (located on the front of the chassis) must be connected to the JF1 connector on the serverboard to provide you with system status indications. These wires have been bundled together as a ribbon cable to simplify the connection.

Connect the cable from JF1 on the serverboard to the appropriate header on the Control Panel PCB (printed circuit board). Make sure the red wire plugs into pin 1 on both connectors. Pull all excess cabling out of the airflow path.

The control panel LEDs inform you of system status. See "Chapter 3: System Interface" for details on the LEDs and the control panel buttons. Details on JF1 can be found in "Chapter 5: Advanced Serverboard Setup."

6-3 System Fans

Four 4-cm heavy duty counter-rotating fans provide the cooling for the SuperServer 6015W-UR/6015W-U/6015W-NTR/6015W-NT. Each fan unit is actually made up of two fans joined back-to-back, which rotate in opposite directions. This counter-rotating action generates exceptional airflow and works to dampen vibration levels. It is very important that the chassis top cover is properly installed and making a good seal in order for the cooling air to circulate properly through the chassis and cool the components. See Figure 6-2.

System Fan Failure

Fan speed is controlled by system temperature via a BIOS setting. If a fan fails, the remaining fan will ramp up to full speed and the overheat/fan fail LED on the control panel will turn on. Replace any failed fan at your earliest convenience with the same type and model (the system can continue to run with a failed fan).

Remove the top chassis cover while the system is still running to determine which of the two fans has failed. Then power down the system before replacing a fan. Removing the power cords is also recommended as a safety precaution.

Replacing System Fans

1. After determining which fan has failed, turn off the power to the system.
2. Unplug the fan cable from the motherboard and remove the failed blower fan from the chassis.
3. Replace the failed fan with an identical 4-cm, 12 volt fan (available from Supermicro: p/n FAN-0086L).
4. Push the new fan into the vacant space in the housing while making sure the arrows on the top of the fan (indicating air direction) point in the same direction as the arrows on the other fans.
5. Reposition the fan housing back over the two mounting posts in the chassis, then reconnect the fan wires to the same chassis fan headers you removed them from.
6. Power up the system and check that the fan is working properly and that the LED on the control panel has turned off. Finish by replacing the chassis cover.

Figure 6-2. System Cooling Fans

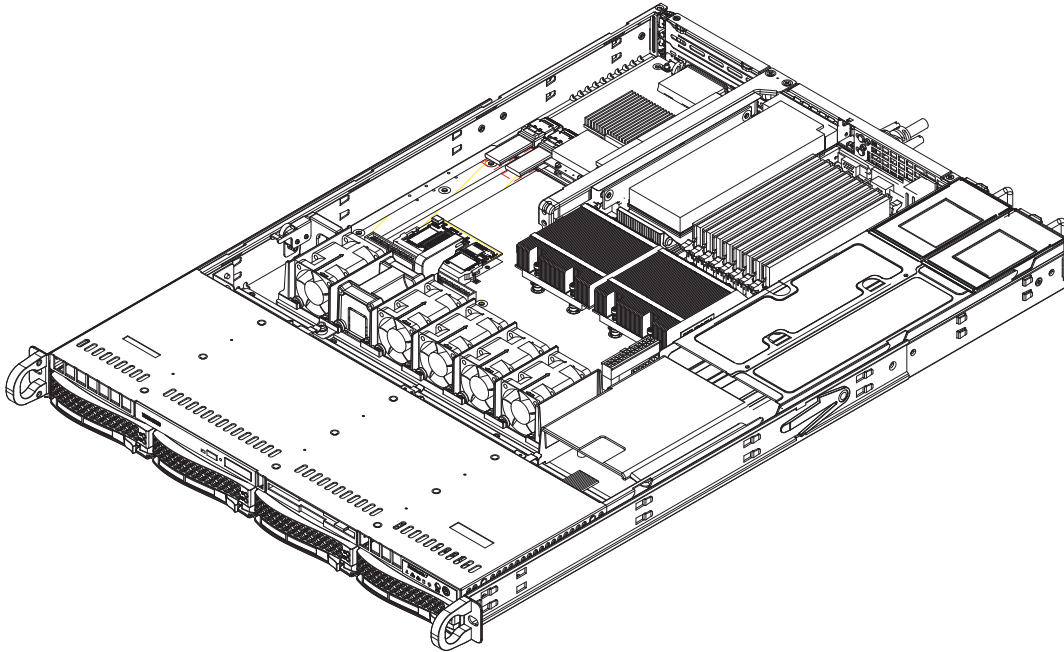

6-4 Drive Bay Installation/Removal

Removing the Front Bezel

If your system has a front bezel (optional) attached to the chassis, you must first remove it to gain access to the drive bays. To remove the bezel, first unlock the front of the chassis then press the release knob (see Figure 6-3). Carefully remove the bezel with both hands. A filter located within the bezel can be removed for replacement/cleaning. It is recommended that you keep a maintenance log of filter cleaning/replacement, since its condition will affect the airflow throughout the whole system.

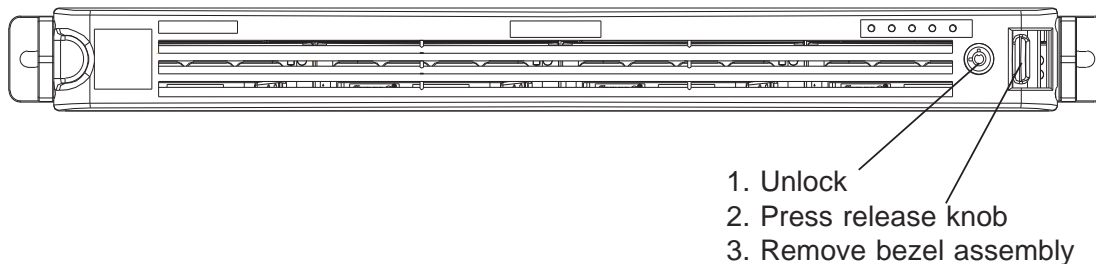
Figure 6-3. Removing the Front Bezel

Accessing the Drive Bays

SATA Drives: Because of their hotswap capability, you do not need to access the inside of the chassis or power down the system to install or replace SATA drives. Proceed to the next section for instructions.

DVD-ROM/Floppy Disk Drives: For installing/removing a DVD-ROM or floppy disk drive, you will need to gain access to the inside of the 6015W-UR/6015W-U/6015W-NTR/6015W-NT by removing the top cover of the chassis. Proceed to the "DVD-ROM and Floppy Drive Installation" section later in this chapter for instructions.

Note: Only "slim" DVD-ROM and floppy drives will fit into the 6015W-UR/6015W-U/6015W-NTR/6015W-NT.

SATA Drive Installation

The SATA drives are mounted in drive carriers to simplify their installation and removal from the chassis. These carriers also help promote proper airflow for the drive bays. For this reason, even empty carriers without drives installed must remain in the chassis.

Mounting a SATA Drive in a Drive Carrier

1. Insert a drive into the carrier with the printed circuit board side facing down so that the mounting holes align with those in the carrier.
2. Secure the drive to the carrier with six screws, as shown in Figure 6-4.

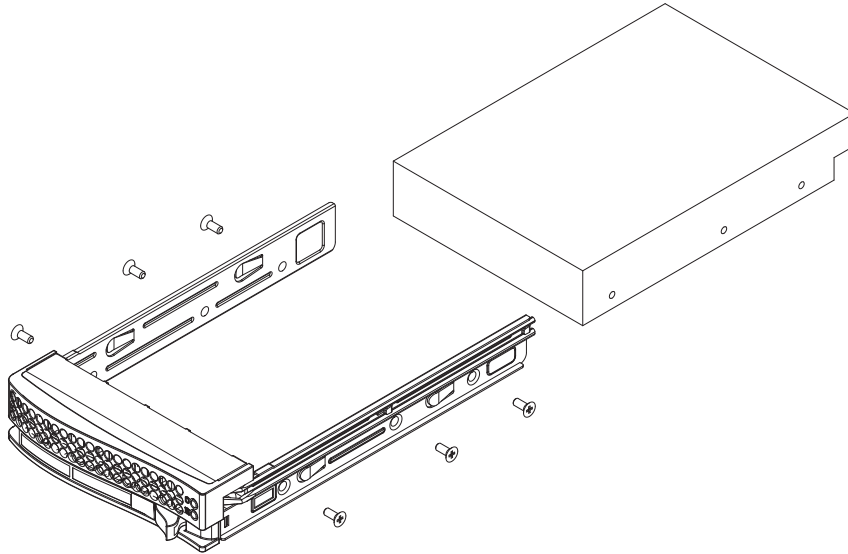

Figure 6-4. Mounting a SATA Drive in a Carrier



Use caution when working around the SATA backplane. Do not touch the backplane with any metal objects and make sure no ribbon cables touch the backplane or obstruct the holes, which aid in proper airflow.



Important: Regardless of how many SATA drives are installed, all drive carriers must remain in the drive bays to maintain proper airflow.

Installing/Removing a SATA Drive

1. To remove a carrier, push the release button located beside the drive LEDs.
2. Swing the colored handle fully out and use it to pull the unit straight out (see Figure 6-5).

Note: Your operating system must have RAID support to enable the hot-plug capability of the SATA drives.

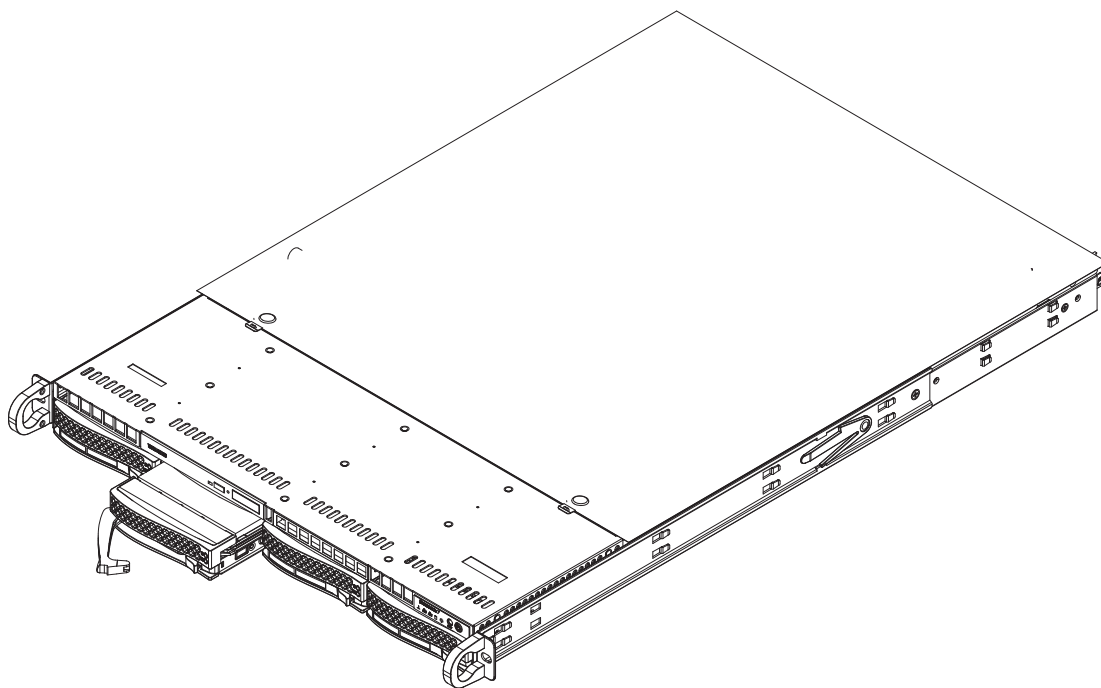

Figure 6-5. Removing a SATA Drive from the Server

DVD-ROM and Floppy Drive Installation

The top cover of the chassis must be opened to gain full access to the DVD-ROM and floppy drive bays. The 6015W-UR/6015W-U/6015W-NTR/6015W-NT accommodates only slim-line DVD-ROM drives. Side mounting brackets are needed to mount a slim-line DVD-ROM drive in the 6015W-UR/6015W-U/6015W-NTR/6015W-NT server. You must power down the system before installing or removing a floppy or DVD-ROM drive.

Removing the Chassis Cover

1. Grasp the two handles on either side and pull the unit straight out until it locks (you will hear a "click").
2. Depress the two buttons on the top of the chassis to release the top cover and at the same time, push the cover away from you until it stops. You can then lift the top cover from the chassis to gain full access to the inside of the server.

Removing/Installing a Drive

1. With the chassis cover removed, unplug the power and data cables from the drive you want to remove.
2. Locate the locking tab at the rear of the drive. It will be on the left side of the drive when viewed from the front of the chassis.
3. Pull the tab away from the drive and push the drive unit out the front of the chassis.
4. Add a new drive by following this procedure in reverse order. You may hear a faint *click* of the locking tab when the drive is fully inserted.
5. Remember to reconnect the data and power cables to the drive before replacing the chassis cover and restoring power to the system.

Please be aware of the following:

- The floppy disk drive cable has seven twisted wires.
- A color mark on a cable typically designates the location of pin 1.
- A single floppy disk drive ribbon cable has 34 wires and two connectors to provide for two floppy disk drives. The connector with twisted wires always

connects to drive A, and the connector that does not have twisted wires always connects to drive B.

6-5 Power Supply

6015W-UR/6015W-NTR

The SuperServer 6015W-UR/6015W-NTR has a 650 watt redundant power supply configuration consisting of two hot-swap power modules. The power supply modules have an auto-switching capability, which enables them to automatically sense and operate with a 100V - 240V input voltage.

Power Supply Failure

If either of the two power supply modules fail, the other module will take the full load and allow the system to continue operation without interruption. The Universal Information LED on the control panel will blink slowly and remain so until the failed module has been replaced. Replacement modules can be ordered directly from Supermicro (see contact information in the Preface). The power supply modules have a hot-swap capability, meaning you can replace the failed module without powering down the system.

Replacing the Power Supply

You do not need to shut down the system to replace a power supply module. The redundant feature will keep the system up and running while you replace the failed hot-swap module. Replace with the same model, which can be ordered directly from Supermicro (see Contact Information in the Preface).

1. First unplug the power cord from the failed power supply module.
2. To remove the failed power module, push the release tab (on the back of the power supply) to the side and then pull the module straight out (see Figure 6-6).
3. The power supply wiring was designed to detach automatically when the module is pulled from the chassis.
4. Replace the failed power module with another PWS-651-1R power supply module.

5. Simply push the new power supply module into the power bay until you hear a click.
6. Finish by plugging the AC power cord back into the module.

6015W-U/6015W-NT

The SuperServer 6015W-U/6015W-NT has a single 560 watt power supply, which is auto-switching capable. This enables it to automatically sense and operate with a 100v - 240v input voltage.

Power Supply Failure

If the power supply module fails, the system will shut down and you will need to replace the module. Replacements can be ordered directly from Supermicro (see contact information in the Preface). As there is only one power supply module in the 6015W-U/6015W-NT, power must be completely removed from the server before removing and replacing the power supply for whatever reason.

Replacing the Power Supply

First turn the power switch on the control panel off, then unplug the power cord from the system. Replace with the same model (p/n PWS-561-1H20), which can be ordered directly from Supermicro (see Contact Information in the Preface).

1. Remove the screws that secure the power supply to the chassis then pull the module straight out with the handle provided (see Figure 6-6, redundant power supply server shown). The power supply wiring was designed to detach automatically when the module is pulled from the chassis.
2. Carefully insert the new power supply into the open bay and push it completely into the chassis until you hear a clicking sound, meaning it has been fully inserted.
3. Secure it to the chassis with the screw you removed previously, then reconnect the AC power cord and depress the power button on the control panel to restart the system.

Figure 6-6. Removing/Replacing the Power Supply

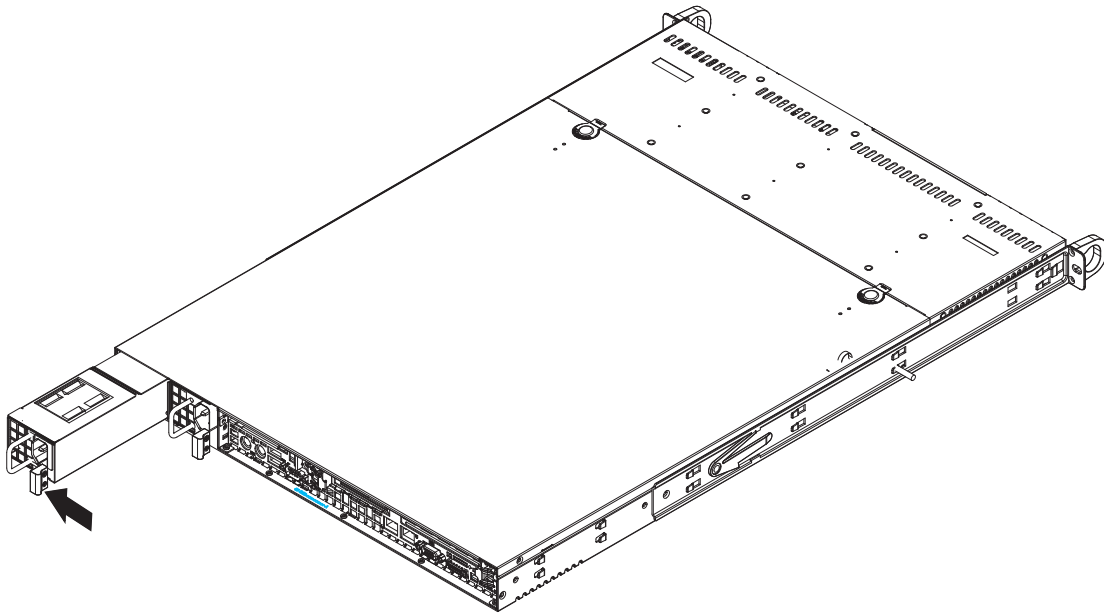

Notes

Chapter 7

BIOS

7-1 Introduction

This chapter describes the Phoenix BIOS™ Setup utility for the X7DWU. The Phoenix ROM BIOS is stored in a flash chip and can be easily upgraded using a floppy disk-based program.

Note: Due to periodic changes to the BIOS, some settings may have been added or deleted and might not yet be recorded in this manual. Please refer to the Manual Download area of the Supermicro web site <<http://www.supermicro.com>> for any changes to the BIOS that may not be reflected in this manual.

System BIOS

The BIOS is the Basic Input Output System used in all IBM® PC, XT™, AT®, and PS/2® compatible computers. The Phoenix BIOS stores the system parameters, types of disk drives, video displays, etc. in the CMOS. The CMOS memory requires very little electrical power. When the computer is turned off, a backup battery provides power to the CMOS Logic, enabling it to retain system parameters. Each time the computer is powered on the computer is configured with the values stored in the CMOS Logic by the system BIOS, which gains control at boot up.

How To Change the Configuration Data

The CMOS information that determines the system parameters may be changed by entering the BIOS Setup utility. This Setup utility can be accessed by pressing the <Delete> key at the appropriate time during system boot. (See below.)

Starting the Setup Utility

Normally, the only visible POST (Power On Self Test) routine is the memory test. As the memory is being tested, press the <Delete> key to enter the main menu of the BIOS Setup utility. From the main menu, you can access the other setup screens, such as the Security and Power menus. Beginning with Section 7-3, detailed descriptions are given for each parameter setting in the Setup utility.



Warning: Do not shut down or reset the system while updating BIOS to prevent possible boot failure.

7-2 Running Setup

Default settings are in bold text unless otherwise noted.

The BIOS setup options described in this section are selected by choosing the appropriate text from the main BIOS Setup screen. All displayed text is described in this section, although the screen display is often all you need to understand how to set the options (See the next page).

When you first power on the computer, the Phoenix BIOS™ is immediately activated.

While the BIOS is in control, the Setup program can be activated in one of two ways:

1. By pressing <Delete> immediately after turning the system on, or
2. When the message shown below appears briefly at the bottom of the screen during the POST (Power On Self-Test), press the <Delete> key to activate the main Setup menu:

Press the <Delete> key to enter Setup

7-3 Main BIOS Setup

All main Setup options are described in this section. The main BIOS Setup screen is displayed below.

Use the Up/Down arrow keys to move among the different settings in each menu. Use the Left/Right arrow keys to change the options for each setting.

Press the <Esc> key to exit the CMOS Setup Menu. The next section describes in detail how to navigate through the menus.

Items that use submenus are indicated with the ► icon. With the item highlighted, press the <Enter> key to access the submenu.

Main BIOS Setup Menu

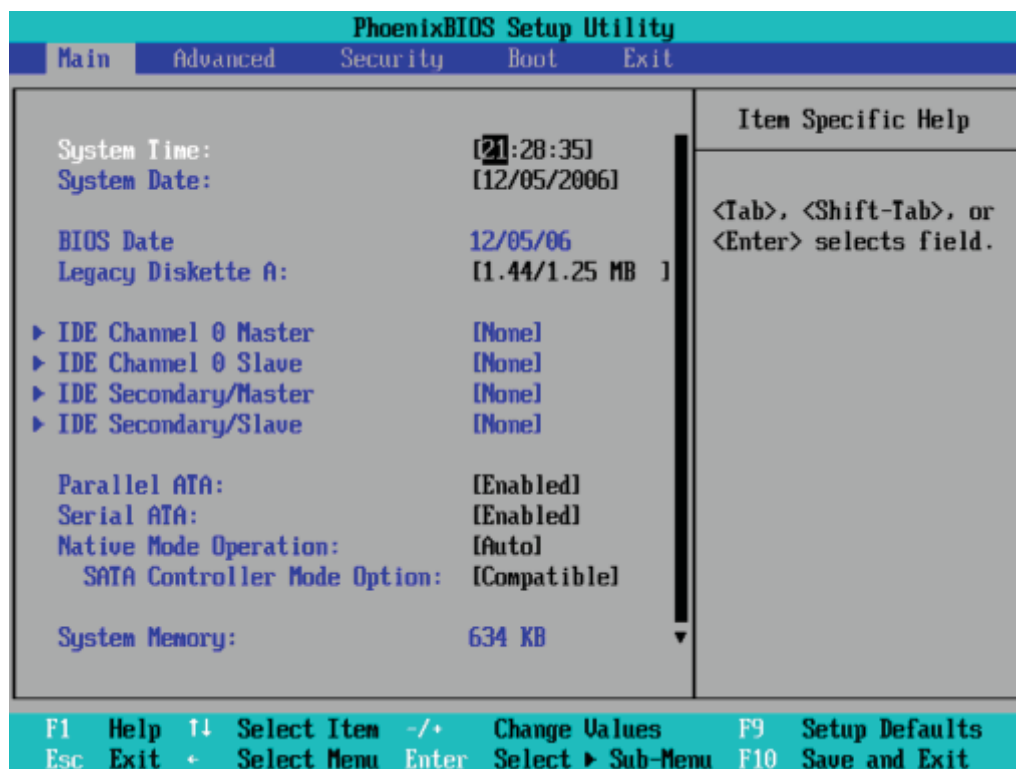

Main Setup Features

System Time

To set the system date and time, key in the correct information in the appropriate fields. Then press the <Enter> key to save the data.

System Date

Using the arrow keys, highlight the month, day and year fields, and enter the correct data. Press the <Enter> key to save the data.

BIOS Date

This field displays the date when this version of BIOS was built.

Legacy Diskette A

This setting allows the user to set the type of floppy disk drive installed as diskette A. The options are Disabled, 360Kb 5.25 in, 1.2MB 5.25 in, 720Kb 3.5 in, 1.44/1.25MB, 3.5 in and 2.88MB 3.5 in.

► IDE Channel 0 Master/Slave and Secondary IDE Master/Slave

These settings allow the user to set the parameters of IDE Channel 0 Master/Slave and Secondary IDE Master/Slave slots. Press <Enter> to activate the following submenu screen for detailed options of these items. Set the correct configurations accordingly.

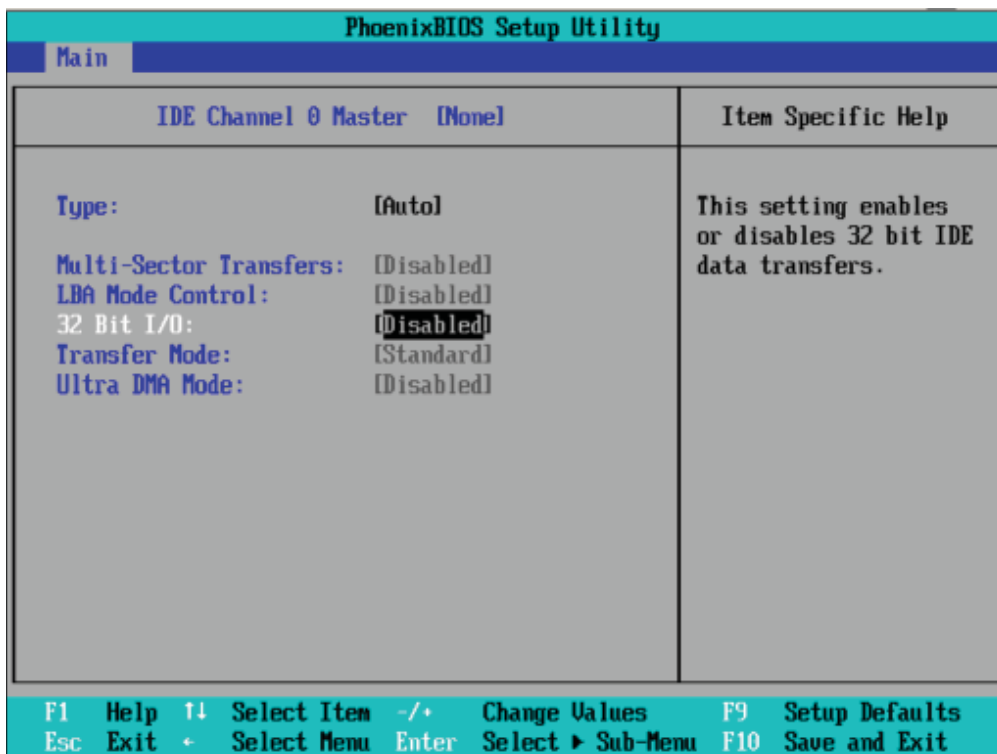

The following items will be displayed in the submenu:

Type

Selects the type of IDE hard drive. The option Auto will allow the BIOS to automatically configure the parameters of the HDD installed at the connection. Enter a number between 1 to 39 to select a predetermined HDD type. Select User to allow the user to enter the parameters of the HDD installed. Select CDROM if a CDROM drive is installed. Select ATAPI if a removable disk drive is installed.

CHS Format

The following items will be displayed by the BIOS:

Type: This item displays the type of IDE or SATA device.

Cylinders: This item indicates the status of cylinders.

Headers: This item indicates the number of headers.

Sectors: This item displays the number of sectors.

Maximum Capacity: This item displays the maximum storage capacity of the system.

LBA Format

Total Sectors: This item displays the number of total sectors available in the LBA Format.

Maximum Capacity: This item displays the maximum capacity in the LBA Format.

Multi-Sector Transfers

This item allows the user to specify the number of sectors per block to be used in multi-sector transfer. The options are Disabled, 4 Sectors, 8 Sectors, and 16 Sectors.

LBA Mode Control

This item determines whether the Phoenix BIOS will access the IDE Channel 0 Master Device via the LBA mode. The options are Enabled and Disabled.

32 Bit I/O

This option allows the user to enable or disable the function of 32-bit data transfer. The options are Enabled and Disabled.

Transfer Mode

This option allows the user to set the transfer mode. The options are Standard, Fast PIO1, Fast PIO2, Fast PIO3, Fast PIO4, FPIO3/DMA1 and FPIO4/DMA2.

Ultra DMA Mode

This option allows the user to select Ultra DMA Mode. The options are Disabled, Mode 0, Mode 1, Mode 2, Mode 3, Mode 4, and Mode 5.

Parallel ATA

This setting allows the user to enable or disable the function of Parallel ATA. The options are Enabled and Disabled.

Serial ATA

This setting allows the user to enable or disable the function of Serial ATA. The options are Disabled and Enabled.

Native Mode Operation

Select the native mode for ATA. The options are Serial ATA and Auto.

Serial ATA (SATA) RAID Enable

Select Enable to enable Serial ATA RAID Functions. (For a Windows OS environment, use the RAID driver if this feature is set to Enabled. When this item is set to Enabled, the item "ICH RAID Code Base" will be available for you to select either Intel or Adaptec Host RAID firmware. If this item is set to Disabled, the item SATA AHCI Enable will be available.) The options are Enabled and Disabled.

ICH RAID Code Base (Available when SATA RAID is Enabled.)

Select Intel to enable Intel's SATA RAID firmware. Select Adaptec to use Adaptec's HostRAID firmware. The options are Intel and Adaptec.

SATA AHCI (Available when SATA RAID is Disabled.)

Select Enable to enable the function of Serial ATA Advanced Host Interface. (Use caution when using this function. This feature is for advanced programmers only.) The options are Enabled and Disabled.

System Memory

This display informs you how much system memory is recognized as being present in the system.

Extended Memory

This display informs you how much extended memory is recognized as being present in the system.

7-4 Advanced Setup

Choose Advanced from the Phoenix BIOS Setup Utility main menu with the arrow keys. You should see the following display.

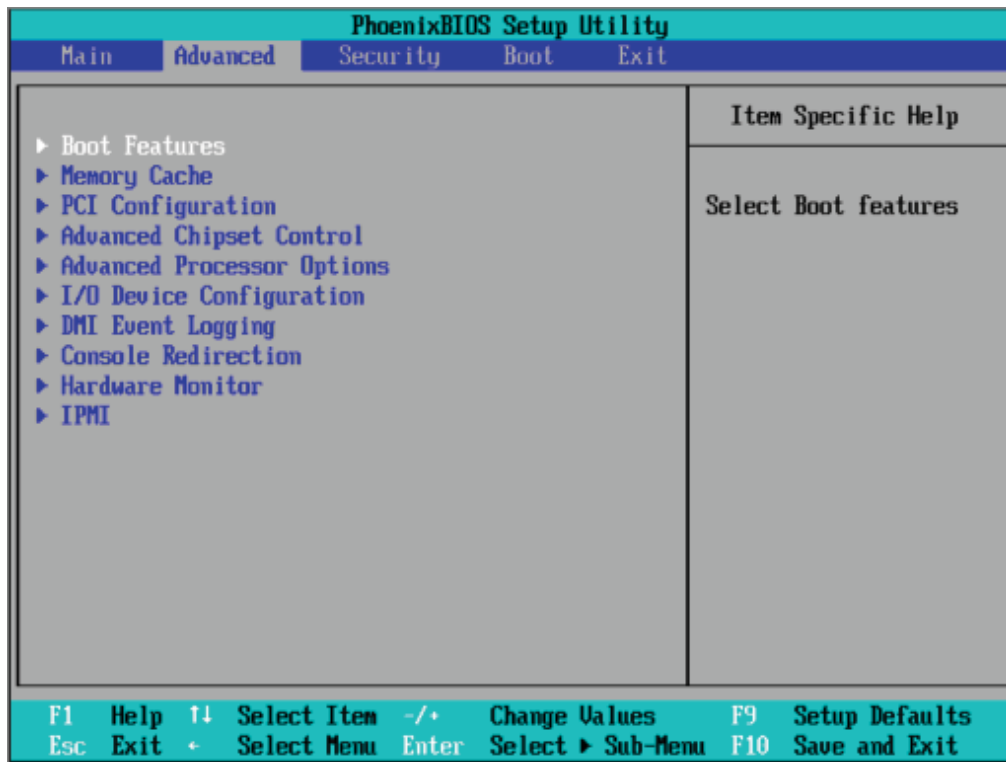

▶ Boot Features

Access the submenu to make changes to the following settings.

QuickBoot Mode

If enabled, this feature will speed up the POST (Power On Self Test) routine by skipping certain tests after the computer is turned on. The settings are Enabled and Disabled. If Disabled, the POST routine will run at normal speed.

QuietBoot Mode

This setting allows you to Enable or Disable the graphic logo screen during boot-up.

POST Errors

Set to Enabled to display POST Error Messages if an error occurs during bootup. If set to Disabled, the system will continue to boot without displaying any error messages even when a boot error occurs.

ACPI Mode

Use the setting to determine if you want to employ ACPI (Advanced Configuration and Power Interface) power management on your system. The options are Yes and No.

Power Button Behavior

If set to Instant-Off, the system will power off immediately as soon as the user hits the power button. If set to 4-sec., the system will power off when the user presses the power button for 4 seconds or longer. The options are **Instant-Off** and 4-sec override.

Resume On Modem Ring

Select On to “wake your system up” when an incoming call is received by your modem. The options are On and **Off**.

EFI OS Boot

If enabled, this feature provides support for EFI OS booting. The options are Enabled and **Disabled**.

Keyboard On Now Function

This feature allows the user to determine how to use the keyboard to power on the system from S3~S5 States. Select Space to allow the user to power on the system by pressing the space bar. Select Password to allow the user to enter the password to power on the system. Select **Disabled** to disable this function.

Set Power On Password

When Password is selected on the item above, the user will be prompted to key in a password of 5-letter long to be used to power on the system.

Power Loss Control

This setting allows you to choose how the system will react when power returns after an unexpected loss of power. The options are Stay Off, Power On and **Last State**.

Watch Dog

If enabled, this option will automatically reset the system if the system is not active for more than 5 minutes. The options are Enabled and **Disabled**.

Summary Screen

This setting allows you to **Enable** or Disable the summary screen which displays the system configuration during bootup.

► Memory Cache

Cache System BIOS Area

This setting allows you to designate a reserve area in the system memory to be used as a System BIOS buffer to allow the BIOS to write (cache) data into this reserved memory area. Select **Write Protect** to enable this function, and this area will be reserved for BIOS ROM access only. Select Uncached to disable this function and make this area available for other devices.

Cache Video BIOS Area

This setting allows you to designate a reserve area in the system memory to be used as a Video BIOS buffer to allow the BIOS to write (cache) data into this reserved memory area. Select **Write Protect** to enable the function and this area will be reserved for Video BIOS ROM access only. Select Uncached to disable this function and make this area available for other devices.

Cache Base 0-512K

If enabled, this feature will allow the data stored in the base memory area block 0-512K to be cached (written) into a buffer, a storage area in Static DRAM (SDRAM) or to be written into the L1, L2 cache inside the CPU to speed up CPU operations. Select Uncached to disable this function. Select Write Through to allow data to be cached into the buffer and written into the system memory at the same time. Select Write Protect to prevent data from being written into the base memory area of Block 0-512K. Select Write Back to allow CPU to write data back directly from the buffer without writing data to the System Memory for fast CPU data processing and operation. The options are Uncached, Write Through, Write Protect, and **Write Back**.

Cache Base 512K-640K

If enabled, this feature will allow the data stored in the memory area 512K-640K to be cached (written) into a buffer, a storage area in the Static DRAM (SDRAM) or written into the L1, L2, L3 cache inside the CPU to speed up CPU operations. Select Uncached to disable this function. Select Write Through to allow data to be cached into the buffer and written into the system memory at the same time. Select Write Protect to prevent data from being written into the base memory area of Block 512-640K. Select Write Back to allow CPU to write data back directly from the buffer without writing data to the System Memory for fast CPU data processing and operation. The options are Uncached, Write Through, Write Protect and **Write Back**.

Cache Extended Memory

If enabled, this feature will allow the data stored in the extended memory area to be cached (written) into a buffer, a storage area in Static DRAM (SDRAM) or written into the L1, L2, L3 cache inside the CPU to speed up CPU operations. Select

Uncached to disable this function. Select Write Through to allow data to be cached into the buffer and written into the system memory at the same time. Select Write Protect to prevent data from being written into the system memory area above 1MB. Select Write Back to allow CPU to write data back directly from the buffer without writing data to the System Memory for fast CPU data processing and operation. The options are Uncached, Write Through, Write Protect and **Write Back**.

Discrete MTRR Allocation

If enabled, MTRRs (Memory Type Range Registers) are configured as distinct, separate units and cannot be overlapped. Set to Enabled to enhance graphic performance when using a Linux graphic driver that requires write-combining configuration with 4GB or more memory. The options are Enabled and **Disabled**.

► PCI Configuration

Access the submenu to make changes to the following settings for PCI devices.

Onboard GLAN1/Onboard GLAN2 (Gigabit- LAN) OPRM Configure

Enabling this option provides the capability to boot from the GLAN port specified. The options are **Disabled** and Enabled.

PCI Parity Error Forwarding

The feature allows SERR and PERR errors detected in PCI slots to be sent (forwarded) to the BIOS DMI Event Log for the user to review. The options are Enabled and **Disabled**.

PCI Fast Delayed Transaction

Enable this function to improve DMA data transfer rate for a PCI 32-bit multimedia card. The options are Enable and **Disabled**.

Reset Configuration Data

If set to Yes, this setting clears the Extended System Configuration Data (ESCD) area. The options are Yes and **No**.

► Slot1 PCI-Exp. x8, Slot2 PCI-Exp. x4, R1 Slot3 PCI-Exp. x4, Slot4 PCI-Exp. x4, Slot5 PCI-Exp. x8, Slot6 PCI-Exp. x4 and Slot0 PCI-Exp. x4

Access the submenu for each of the settings above to make changes to the following:

Option ROM Scan

When enabled, this setting will initialize the device expansion ROM. The options are **Enabled** and Disabled.

Enable Master

This setting allows you to enable the selected device as the PCI bus master. The options are **Enabled** and Disabled.

Latency Timer

This setting allows you to set the clock rate for Bus Master. A high-priority, high-throughput device may benefit from a greater clock rate. The options are **Default**, 0020h, 0040h, 0060h, 0080h, 00A0h, 00C0h and 00E0h. For Unix, Novell and other Operating Systems, please select the Other option. If a drive fails after the installation of new software, you might want to change this setting and try again. A different OS requires a different Bus Master clock rate.

Large Disk Access Mode

This setting determines how large hard drives are to be accessed. The options are **DOS** or Other (for Unix, Novelle NetWare and other operating systems).

► Advanced Chipset Control

Access the submenu to make changes to the following settings.



Warning: Use caution when changing the Advanced settings. Incorrect values entered may cause system malfunction. Also, a very high DRAM frequency or incorrect DRAM timing may cause system instability. When this occurs, revert to the default settings.

SERR Signal Condition

This setting specifies the ECC Error conditions that an SERR# is to be asserted. The options are None, **Single Bit**, Multiple Bit and Both.

Clock Spectrum Feature

If Enabled, the BIOS will monitor the level of electromagnetic interference caused by the components and will attempt to decrease the interference whenever needed. The options are Enabled and **Disabled**.

► Intel VT for Directed I/O

Select Enabled to bring up the following Intel VT for Directed I/O (VT-d) configuration submenu. The options are Enabled and Disabled.

VT-d for Port 0 (ESI)/VT-d for Port 1/VT-d for Port 5/VT-d for Port 9/VT-d for DMI Port

Select Enabled to enable VT-d support for the port specified through DRHD Structures in the ACPI Tables. The options are Disabled and Enabled.

Memory Voltage

This feature allows the user to set memory voltage for onboard memory modules. Select auto to allow the BIOS to automatically detect the onboard memory voltage according to the status of its SPD (Serial Presence Detect). Select 1.5V to force the memory modules to run on 1.5V to accommodate lower-power FBDIMM (Fully Buffered DIMM). Select 1.8V to force the memory module to run on 1.8 for testing. The options are **Auto**, 1.5V and 1.8V. Warning: If set to 1.8V, damage may occur to FBDIMM memory modules that only support 1.5V.

4GB PCI Hole Granularity

This feature allows you to select the granularity of PCI hole for PCI slots. If MTRRs are not enough, this option may be used to reduce MTRR occupation. The options are **256 MB**, 512 MB, 1GB and 2GB.

Memory Branch Mode

This option determines how the two memory branches operate. System address space can either be interleaved between the two branches or Sequential from one branch to another. Mirror mode allows data correction by maintaining two copies of data in two branches. Single Channel 0 allows a single DIMM population during system manufacturing. The options are **Interleave**, Sequential, Mirroring and Single Channel 0.

Branch 0 Rank Interleaving & Sparing

Select enable to enable the functions of Memory Interleaving and Memory Sparing for Branch 0 Rank. The options for Memory Interleaving are 1:1, 2:1 and **4:1**. The options for Sparing are Enabled and **Disabled**.

Branch 1 Rank Interleaving & Sparing

Select enable to enable the functions of Memory Interleaving and Memory Sparing for Branch 1 Rank. The options for Memory Interleaving are 1:1, 2:1 and **4:1**. The options for Sparing are Enabled and **Disabled**.

Enhanced x8 Detection

Select Enabled to enable Enhanced x8 DRAM UC Error Detection. The options are Disabled and **Enabled**.

Demand Scrubbing

Scrubbing is a process that allows the North Bridge to correct correctable memory errors found on an FBD memory module. When the CPU or I/O issues a demand read command, and the read data from memory turns out to be a correctable ECC, it is corrected and sent to the original source. Memory is updated as well. Select Enabled to use Demand Scrubbing for ECC memory correction. The options are **Enabled** and Disabled.

High Temperature DRAM Operation

When set to Enabled, the BIOS will refer to the SPD table to set the maximum DRAM temperature. If disabled, the BIOS will set the maximum DRAM temperature based on a predefined value. The options are Enabled and **Disabled**.

AMB Thermal Sensor

Select Enabled to activate the thermal sensor embedded in the Advanced Memory Buffer on a fully buffered memory module for thermal monitoring. The options are **Disabled** and Enabled.

Thermal Throttle

Select Enabled to enable closed-loop thermal throttling on a fully buffered (FBD) memory module. In the closed-loop thermal environment, thermal throttling will be activated when the temperature of the FBD DIMM module exceeds a predefined threshold. The options are Enabled and **Disabled**.

Global Activation Throttle

Select Enabled to enable open-loop global thermal throttling on a fully buffered (FBD) memory module to make it active whenever the number of activate control exceeds a predefined number. The options are Enabled and **Disabled**.

Force ITK Configuration Clocking

Select Enabled to configure FBD clock settings to support ITK testing. The options are **Disabled** and Enabled.

Reserved Branch for ITK Test

This feature allows the user to specify the memory branch number to be reserved for ITK testing. The default setting is **Branch 1**.

Snoop Filter

Select Enabled to eliminate snoop traffic to the graphics port to greatly improve system performance when running graphics intensive applications. The options are **Enabled** and Disabled.

Crystal Beach Features

This feature was designed to implement Intel's I/O AT (Acceleration Technology) to accelerate the performance of TOE devices. (A TOE device is a specialized, dedicated processor that is installed on an add-on card or a network card to handle some or all packet processing of the add-on card. For this motherboard, the TOE device is built inside the ESB2 South Bridge chip.) Options are **Enabled** and Disabled.

Route Port 80h Cycles to

This feature allows the user to decide which bus to send debug information to. The options are PCI and **LPC**.

► Advanced Processor Options

Access the submenu to make changes to the following settings.

CPU Speed

This is a display that indicates the speed of the installed processor.

Frequency Ratio (Available when supported by the CPU)

This feature allows the user to set the internal frequency multiplier for the CPU. The options are **Default** and x12.

Machine Checking (Available when supported by the CPU)

Set to Enabled to use this function, which allows the CPU to detect and report hardware (machine) errors via a set of model-specific registers (MSRs). The options are Disabled and **Enabled**.

Fast String Operations (Available if supported by the CPU)

Set to Enabled to enable the fast string operations for special CPU instructions. The options are Disabled and **Enabled**.

Thermal Management 2 (Available if supported by the CPU)

Set to Enabled to use Thermal Management 2 (TM2) which will lower CPU voltage and frequency when the CPU temperature reaches a predefined overheat threshold. Set to Disabled to use Thermal Manager 1 (TM1), allowing CPU clocking to be

regulated via CPU Internal Clock modulation when the CPU temperature reaches the overheat threshold.

C1/C2 Enhanced Mode (Available when supported by the CPU)

Set to Enabled to enable Enhanced Halt State (C1) and Stop Clock State (C2) to lower CPU voltage/frequency to prevent overheat. The options are Enabled and **Disabled**. Note: please refer to Intel's web site for detailed information.

Execute Disable Bit (Available when supported by the CPU)

Set to Enabled to allow the processor to classify areas in memory where an application code can execute and where it cannot, and thus preventing a worm or a virus from inserting and creating a flood of codes to overwhelm the processor or damage the system during an attack.

Note: this feature is available when your OS and your CPU support the Execute Disable Bit function. The options are **Disabled** and Enabled. (For more information regarding hardware/software support for this function, please refer to Intel's and Microsoft's web sites.)

Adjacent Cache Line Prefetch (Available when supported by the CPU)

The CPU fetches the cache line for 64 bytes if this option is set to Disabled. The CPU fetches both cache lines for 128 bytes as comprised if Enabled. The default settings are **Disabled** for Intel 5100 Series Processors and **Enabled** for 5000 Series Processors.

Hardware Prefetcher (Available when supported by the CPU)

Set to Enabled to activate the hardware components that are used in conjunction with software programs to prefetch data in order to shorten execution cycles and maximize data processing efficiency. The options are Disabled and **Enabled**.

Set Maximum Ext. CPUID=3

When set to Enabled, the Maximum Extended CPUID will be set to 3. The options are **Disabled** and Enabled.

Direct Cache Access (Available when supported by the CPU)

Set to Enable to route inbound network IO traffic directly into processor caches to reduce memory latency and improve network performance. The options are **Disabled** and Enabled.

DCA Delay Clocks (Available if supported by the CPU)

This feature allows the user to set the clock delay setting from snoop to prefetch for Direct Cache Access. Select a setting from 8 (bus cycles) to 120 (bus cycles) (in 8-cycle increment). The default setting is 32 (bus cycles).

Intel <R> Virtualization Technology (Available when supported by the CPU)

Select Enabled to use the feature of Virtualization Technology to allow one platform to run multiple operating systems and applications in independent partitions, creating multiple "virtual" systems in one physical computer. The options are Enabled and **Disabled**. (Note: If there is any change to this setting, you will need to power off and restart the system for the change to take effect.) Please refer to Intel's web site for detailed information.

Intel EIST Support (Available when supported by the CPU)

Select Enabled to use the Enhanced Intel SpeedStep Technology and allows the system to automatically adjust processor voltage and core frequency in an effort to reduce power consumption and heat dissipation. The options are Enabled and **Disabled**. Please refer to Intel's web site for detailed information.

C State Supported (Available if supported by the CPU)

This feature allows the user to choose the ACPI Power Management State to be supported by the BIOS. Select C1 to activate the Enhanced Halt State mode in order to reduce power consumption. Select C2 to activate the Stop-Clock mode to keep all CPU software visible. Select C3 to activate the Sleep State mode when the CPU does not need to keep its cache coherent but maintains other states. Select C4 to activate the package-level lower-power mode after each core of CPUs has been set to C3 State in an effort to further reduce power consumption. The options are **C1**, C1C2 (C1 & C2), C1C2C3 (C1, C2 & C3), and C1C2C3C4 (C1, C2, C3 & C4). Please refer to Intel's web site for details.

► I/O Device Configuration

Access the submenu to make changes to the following settings.

KBC Clock Input

This setting allows you to select clock frequency for KBC. The options are 6MHz, 8MHz, **12MHz** and 16MHz.

Serial Port A

This setting allows you to assign control of serial port A. The options are **Enabled** (user defined), Disabled, and Auto (BIOS or OS controlled).

Base I/O Address

This setting allows you to select the base I/O address for serial port A. The options are **3F8**, 2F8, 3E8 and 2E8.

Interrupt

This setting allows you to select the IRQ (interrupt request) for serial port A. The options are IRQ3 and **IRQ4**.

Floppy Disk Controller

This setting allows you to assign control of the floppy disk controller. The options are **Enabled** (user defined), Disabled and Auto (BIOS and OS controlled).

Base I/O Address

This setting allows you to select the base I/O address for the Floppy port. The options are **Primary** and Secondary.

► DMI Event Logging

Access the submenu to make changes to the following settings.

Event Log Validity

This is a display to inform you of the event log validity. It is not a setting.

Event Log Capacity

This is a display to inform you of the event log capacity. It is not a setting.

View DMI Event Log

Highlight this item and press <Enter> to view the contents of the event log.

Event Logging

This setting allows you to **Enable** or Disable event logging.

ECC Event Logging

This setting allows you to **Enable** or Disable ECC event logging.

Mark DMI Events as Read

Highlight this item and press <Enter> to mark the DMI events as read.

Clear All DMI Event Logs

Select Yes and press <Enter> to clear all DMI event logs. The options are Yes and **No**.

► Console Redirection

Access the submenu to make changes to the following settings.

COM Port Address

This item allows you to specify which COM port to direct the remote console to: Onboard COM A or Onboard COM B. This setting can also be **Disabled**.

BAUD Rate

This item allows you to set the BAUD rate for console redirection. The options are 300, 1200, 2400, 9600, **19.2K**, 38.4K, 57.6K and 115.2K.

Console Type

This item allows you to set console redirection type. The options are VT100, VT100,8bit, PC-ANSI, 7bit, **PC ANSI**, VT100+, VT-UTF8 and ASCII.

Flow Control

This item allows you to select the flow control option for console redirection. The options are None, XON/XOFF and **CTS/RTS**.

Console Connection

This item allows you to decide how console redirection is to be connected: either **Direct** or Via Modem.

Continue CR after POST

Choose whether to continue with console redirection after the POST routine. The options are On and **Off**.

► Hardware Monitor Logic

Highlight this and hit <Enter> to see monitor data for the following items:

CPU1 Temperature

CPU1 Second Core Temperature

CPU2 Temperature

CPU2 Second Core Temperature

System Temperature

Fan1-Fan8 Speeds

If the feature of Auto Fan Control is enabled, the BIOS will automatically display the status of the fans indicated in this item.

Fan Speed Control Modes

This feature allows the user to decide how the system controls the speeds of the onboard fans. The CPU temperature and the fan speed are correlative. When the CPU on-die temperature increases, the fan speed will also increase, and vice versa. If the option is set to 3-pin fan, the fan speed is controlled by voltage. If the option is set to 4-pin, the fan speed will be controlled by Pulse Width Modulation (PWM). Select 3-pin if your chassis came with 3-pin fan headers. Select 4-pin if your chassis came with 4-pin fan headers. Select Workstation if your system is used as a Workstation. Select Server if your system is used as a Server. Select Disable to disable fan speed control and allow the onboard fans to constantly run at full speed (12V). The Options are: **1. Disable**, 2. 3-pin (Server), 3. 3-pin (Workstation), 4. 4-pin (Server) and 5. 4-pin (Workstation).

Voltage Monitoring

The following items will be monitored and displayed:

Vcore A, Vcore B, -12V/+12V, P1V5P_VTT/bat, +3.3V, 5Vsb/5VDD

► IPMI (Available only when an IPMI card is installed in the system)

PhoenixBIOS Setup Utility		Item Specific Help
Advanced		
IPMI		
IPMI Specification Version	2.0	Enable/Disable IPMI event logging. Disabling will still log events received via the system interface.
Firmware Version	2.1	
System Event Logging	[Enabled]	
Clear System Event Log	[Disabled]	
Existing Event Log number	282	
Event Log Control		
SYS Firmware Progress	[Disabled]	
BIOS POST Errors	[Enabled]	
BIOS POST Watchdog	[Disabled]	
OS boot Watchdog	[Disabled]	
Timer for loading OS (min)	[10]	
Time out action	[No Action]	

IPMI Specification Version: This item displays the current IPMI Version.

Firmware Version: This item displays the current Firmware Version.

System Event Logging

Select Enabled to enable IPMI Event Logging. When this function is set to Disabled, the system will continue to log events received via system interface. The options are **Enabled** and Disabled.

Clear System Event Logging

Enabling this function to force the BIOS to clear the system event logs during the next cold boot. The options are Enabled and **Disabled**.

Existing Event Log Number

This item displays the number of the existing event log.

Event Log Control

System Firmware Progress

Enable this function to log POST progress. The options are Enabled and **Disabled**.

BIOS POST Errors

Enabling this function to log POST errors. The options are Enabled and **Disabled**.

BIOS POST Watch Dog

Set to Enabled to enable POST Watch Dog. The options are Enabled and **Disabled**.

OS Boot Watch Dog

Set to Enabled to enable OS Boot Watch Dog. The options are Enabled and **Disabled**.

Timer for Loading OS (Minutes)

This feature allows the user to set the time value (in minutes) for the previous item (OS Boot Watch Dog) by keying-in a desired number in the blank. The default setting is **10 (minutes)**. (Please ignore this option when OS Boot Watch Dog is set to Disabled.)

Time Out Option

This feature allows the user to determine what action to take in an event of a system boot failure. The options are **No Action**, Reset, Power Off and Power Cycles.

► System Event Log/System Event Log (List Mode)

These options display the System Event (SEL) Log and System Event (SEL) Log in List Mode. Items included are shown in the screen shot below.

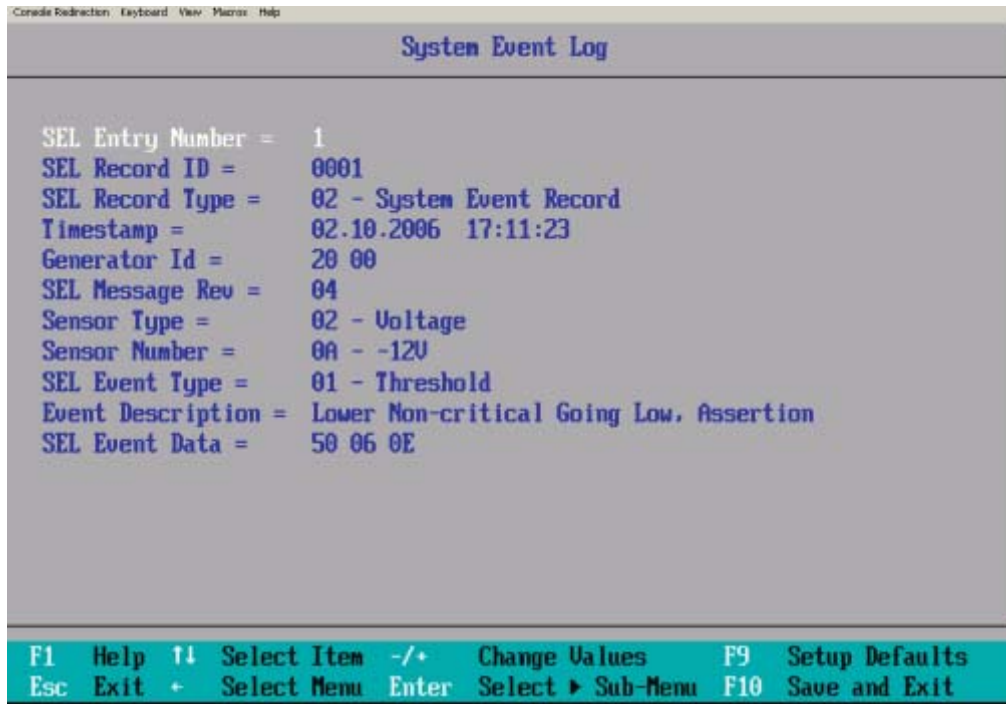

► Realtime Sensor Data

This feature display information from motherboard sensors, such as temperatures, fan speeds and the voltages of various components.

Sensor Type	Sensor Name	Sensor Data	Sensor Units	Lower Limit	Upper Limit
Temp					
	CPU1 CoreA	48.00	degrees C	0.00	75.00
	CPU1 CoreB	54.00	degrees C	0.00	75.00
	CPU2 CoreA	47.00	degrees C	0.00	75.00
	CPU2 CoreB	46.00	degrees C	0.00	75.00
	System	44.00	degrees C	0.00	75.00
Voltage					
	CPU1 Core	1.13	Volts	0.97	1.47
	CPU2 Core	1.16	Volts	0.97	1.47
	3.3V	3.30	Volts	2.95	3.62

```

Console Redirection Keyboard View Macros Help
Realtime Sensor Data

Sensor Type  Sensor Name  Sensor Data  Sensor Units  Lower Limit  Upper Limit
-----
Temp
CPU1 CoreA  48.00        degrees C    0.00          75.00
CPU1 CoreB  54.00        degrees C    0.00          75.00
CPU2 CoreA  47.00        degrees C    0.00          75.00
CPU2 CoreB  46.00        degrees C    0.00          75.00
System      44.00        degrees C    0.00          75.00
Voltage
CPU1 Core   1.13         Volts        0.97          1.47
CPU2 Core   1.16         Volts        0.97          1.47
3.3V        3.30         Volts        2.95          3.62

F1 Help F2 Select Item -/+ Change Values F9 Setup Defaults
Esc Exit + Select Menu Enter Select Sub-Menu F10 Save and Exit
  
```

7-5 Security

Choose Security from the Phoenix BIOS Setup Utility main menu with the arrow keys. You should see the following display. Security setting options are displayed by highlighting the setting using the arrow keys and pressing <Enter>. All Security BIOS settings are described in this section.

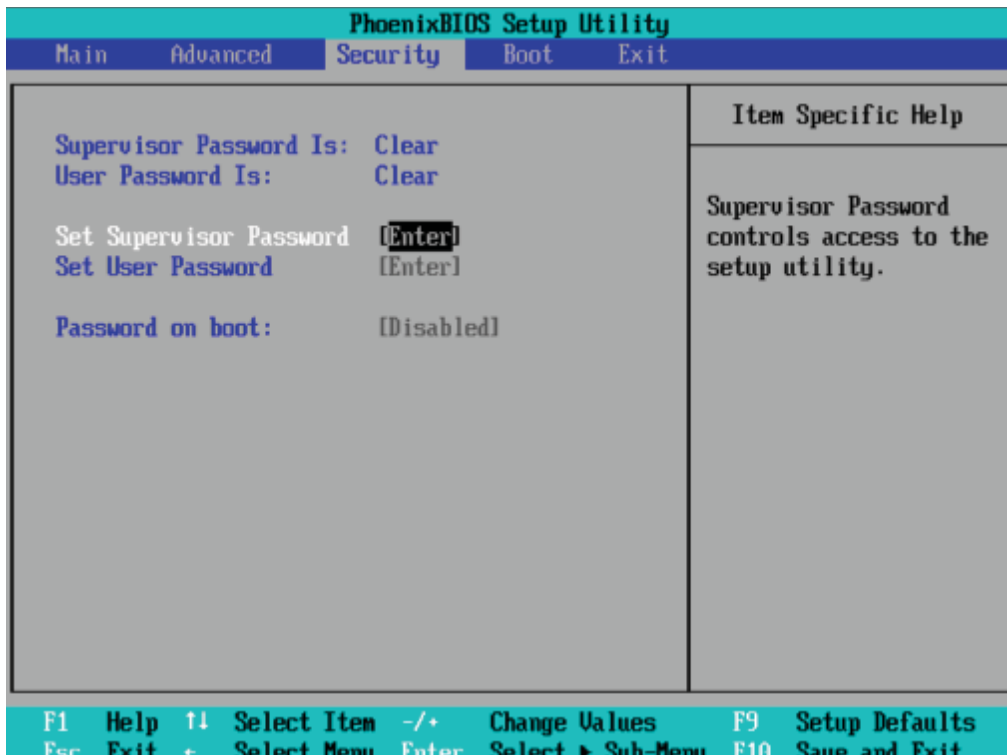

Supervisor Password Is:

This feature indicates if a supervisor password has been entered to the system. Clear means such a password has not been used and Set means a supervisor password has been entered.

User Password Is:

This feature indicates if a user password has been entered to the system. Clear means such a password has not been used and Set means a user password has been entered.

Set Supervisor Password

When the item Set "Supervisor Password" is highlighted, hit the <Enter> key. When prompted, type the Supervisor's password in the dialogue box to set or to change supervisor's password, which allows access to the BIOS.

Set User Password

When the item "Set User Password" is highlighted, hit the <Enter> key. When prompted, type the user's password in the dialogue box to set or to change the user's password, which allows access to the system at boot-up.

Password on Boot

This setting allows you to determine if a password is required for a user to enter the system at system boot. The options are **Enabled** (password required) and Disabled (password not required).

TPM (Trusted Platform Modules) Support

Select Enabled to enable support for trusted platforms and allow the BIOS to automatically download the drivers needed to provide support for the platforms specified. The options are Enabled and Disabled. If set to Enabled, the TPM State screen displays.

Current TPM State

This item shows the current TPM State only.

Change TPM State

Select Enabled & Activate to enable TPM support for the system. Select De-activate & Disabled to disable the function of TPM support. If No Change is selected, no changes will be done to the current TPM State. Select Clear to clear or erase all information related to TPM support. If set to Clear, the sub-menu Physical Presence Operations will appear. Select Reject to cancel the selection. Select Execute to proceed with selection. All information related to TPM Support will be erased.

7-6 Boot

Choose Boot from the Phoenix BIOS Setup Utility main menu with the arrow keys. You should see the following display. See details on how to change the order and specs of boot devices in the Item Specific Help window. All Boot BIOS settings are described in this section.

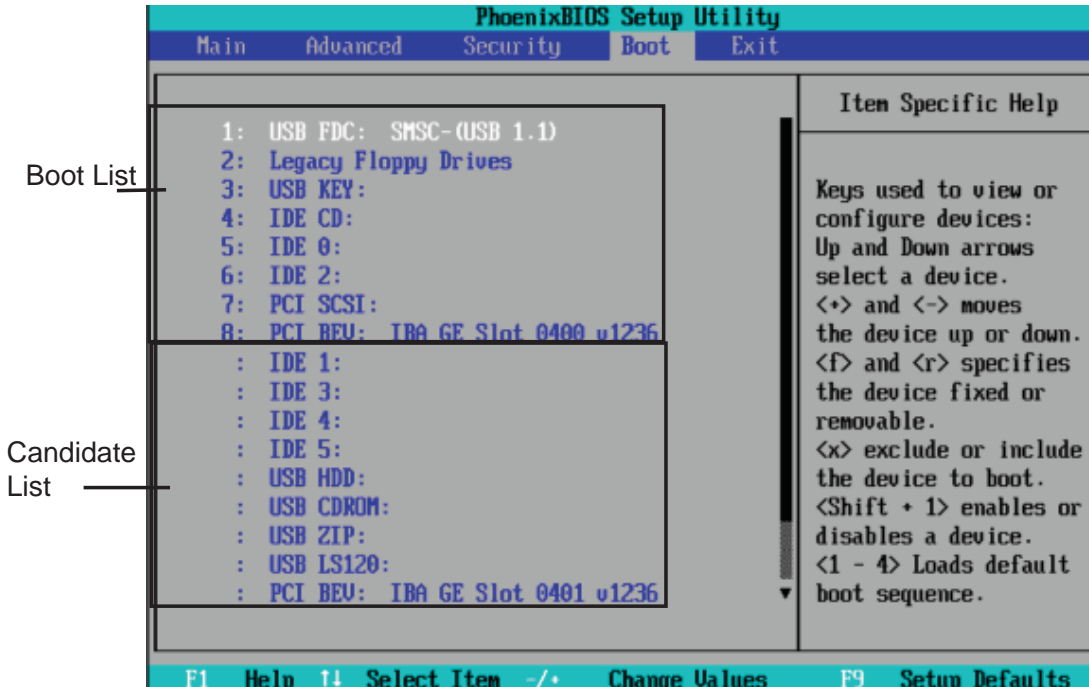

Boot Priority Order/Excluded from Boot Orders

The devices included in the boot list section (above) are bootable devices listed in the sequence of boot order as specified. The boot functions for the devices included in the candidate list (above) are currently disabled.

Use a <+> key or a <-> key to move the device up or down. Use the <f> key or the <r> key to specify the type of an USB device, either fixed or removable. You can select one item from the boot list and hit the <x> key to remove it from the list of bootable devices (to make its resource available for other bootable devices). Subsequently, you can select an item from the candidate list and hit the <x> key to remove it from the candidate list and put it in the boot list. This item will then become a bootable device.

See details on changing the boot priority order of a device in the "Item Specific Help" window.

7-7 Exit

Choose Exit from the Phoenix BIOS Setup Utility main menu with the arrow keys. You should see the following display. All Exit BIOS settings are described in this section.

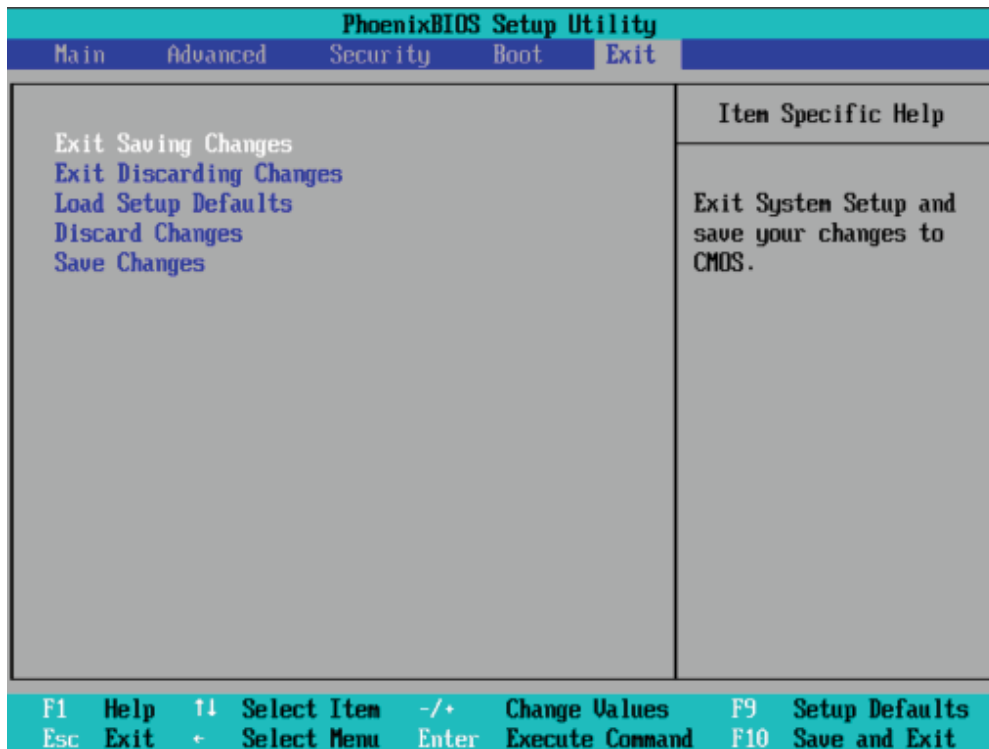

Exit Saving Changes

Highlight this item and hit <Enter> to save any changes you've made and to exit the BIOS Setup utility.

Exit Discarding Changes

Highlight this item and hit <Enter> to exit the BIOS Setup utility without saving any changes you may have made.

Load Setup Defaults

Highlight this item and hit <Enter> to load the default settings for all items in the BIOS Setup. These are the safest settings to use.

Discard Changes

Highlight this item and hit <Enter> to discard (cancel) any changes you've made. You will remain in the Setup utility.

Save Changes

Highlight this item and hit <Enter> to save any changes you've made. You will remain in the Setup utility.

Notes

Appendix A

BIOS POST Messages

During the Power-On Self-Test (POST), the BIOS will check for problems. If a problem is found, the BIOS will activate an alarm or display a message. The following is a list of such BIOS messages.

Failure Fixed Disk

Fixed disk is not working or not configured properly. Check to see if fixed disk is attached properly. Run Setup. Find out if the fixed-disk type is correctly identified.

Stuck key

Stuck key on keyboard.

Keyboard error

Keyboard not working.

Keyboard Controller Failed

Keyboard controller failed test. May require replacing keyboard controller.

Keyboard locked - Unlock key switch

Unlock the system to proceed.

Monitor type does not match CMOS - Run SETUP

Monitor type not correctly identified in Setup

Shadow Ram Failed at offset: nnnn

Shadow RAM failed at offset **nnnn** of the 64k block at which the error was detected.

System RAM Failed at offset: nnnn

System RAM failed at offset **nnnn** of in the 64k block at which the error was detected.

Extended RAM Failed at offset: nnnn Extended memory not working or not configured properly at offset **nnnn**.

System battery is dead - Replace and run SETUP

The CMOS clock battery indicator shows the battery is dead. Replace the battery and run Setup to reconfigure the system.

System CMOS checksum bad - Default configuration used

System CMOS has been corrupted or modified incorrectly, perhaps by an application program that changes data stored in CMOS. The BIOS installed Default Setup Values. If you do not want these values, enter Setup and enter your own values. If the error persists, check the system battery or contact your dealer.

System timer error

The timer test failed. Requires repair of system board.

Real time clock error

Real-Time Clock fails BIOS hardware test. May require board repair.

Check date and time settings

BIOS found date or time out of range and reset the Real-Time Clock. May require setting legal date (1991-2099).

Previous boot incomplete - Default configuration used

Previous POST did not complete successfully. POST loads default values and offers to run Setup. If the failure was caused by incorrect values and they are not corrected, the next boot will likely fail. On systems with control of **wait states**, improper Setup settings can also terminate POST and cause this error on the next boot. Run Setup and verify that the waitstate configuration is correct. This error is cleared the next time the system is booted.

Memory Size found by POST differed from CMOS

Memory size found by POST differed from CMOS.

Diskette drive A error

Diskette drive B error

Drive A: or B: is present but fails the BIOS POST diskette tests. Check to see that the drive is defined with the proper diskette type in Setup and that the diskette drive is attached correctly.

Incorrect Drive A type - run SETUP

Type of floppy drive A: not correctly identified in Setup.

Incorrect Drive B type - run SETUP

Type of floppy drive B: not correctly identified in Setup.

System cache error - Cache disabled

RAM cache failed and BIOS disabled the cache. On older boards, check the cache jumpers. You may have to replace the cache. See your dealer. A disabled cache slows system performance considerably.

CPU ID:

CPU socket number for Multi-Processor error.

EISA CMOS not writeable

ServerBIOS2 test error: Cannot write to EISA CMOS.

DMA Test Failed

ServerBIOS2 test error: Cannot write to extended **DMA** (Direct Memory Access) registers.

Software NMI Failed

ServerBIOS2 test error: Cannot generate software NMI (Non-Maskable Interrupt).

Fail-Safe Timer NMI Failed

ServerBIOS2 test error: Fail-Safe Timer takes too long.

device Address Conflict

Address conflict for specified **device**.

Allocation Error for: device

Run ISA or EISA Configuration Utility to resolve resource conflict for the specified **device**.

CD ROM Drive

CD ROM Drive identified.

Entering SETUP ...

Starting Setup program

Failing Bits: nnnn

The hex number **nnnn** is a map of the bits at the RAM address which failed the memory test. Each 1 (one) in the map indicates a failed bit. See errors 230, 231, or 232 above for offset address of the failure in System, Extended, or Shadow memory.

Fixed Disk n

Fixed disk n (0-3) identified.

Invalid System Configuration Data

Problem with NVRAM (CMOS) data.

I/O device IRQ conflict

I/O device IRQ conflict error.

PS/2 Mouse Boot Summary Screen:

PS/2 Mouse installed.

nnnn kB Extended RAM Passed

Where nnnn is the amount of RAM in kilobytes successfully tested.

nnnn Cache SRAM Passed

Where nnnn is the amount of system cache in kilobytes successfully tested.

nnnn kB Shadow RAM Passed

Where nnnn is the amount of shadow RAM in kilobytes successfully tested.

nnnn kB System RAM Passed

Where nnnn is the amount of system RAM in kilobytes successfully tested.

One or more I2O Block Storage Devices were excluded from the Setup Boot Menu

There was not enough room in the IPL table to display all installed I2O block-storage devices.

Operating system not found

Operating system cannot be located on either drive A: or drive C:. Enter Setup and see if fixed disk and drive A: are properly identified.

Parity Check 1 nnnn

Parity error found in the system bus. BIOS attempts to locate the address and display it on the screen. If it cannot locate the address, it displays ?????. Parity is a method for checking errors in binary data. A parity error indicates that some data has been corrupted.

Parity Check 2 nnnn

Parity error found in the I/O bus. BIOS attempts to locate the address and display it on the screen. If it cannot locate the address, it displays ????.

Press <F1> to resume, <F2> to Setup, <F3> for previous

Displayed after any recoverable error message. Press <F1> to start the boot process or <F2> to enter Setup and change the settings. Press <F3> to display the previous screen (usually an initialization error of an **Option ROM**, i.e., an add-on card). Write down and follow the information shown on the screen.

Press <F2> to enter Setup

Optional message displayed during POST. Can be turned off in Setup.

PS/2 Mouse:

PS/2 mouse identified.

Run the I2O Configuration Utility

One or more unclaimed block storage devices have the Configuration Request bit set in the LCT. Run an I2O Configuration Utility (e.g. the SAC utility).

System BIOS shadowed

System BIOS copied to shadow RAM.

UMB upper limit segment address: *nnnn*

Displays the address *nnnn* of the upper limit of **Upper Memory Blocks**, indicating released segments of the BIOS which can be reclaimed by a virtual memory manager.

Video BIOS shadowed

Video BIOS successfully copied to shadow RAM.

Notes

Appendix B

BIOS POST Codes

This section lists the POST (Power On Self Test) codes for the PhoenixBIOS. POST codes are divided into two categories: recoverable and terminal.

Recoverable POST Errors

When a recoverable type of error occurs during POST, the BIOS will display an POST code that describes the problem. BIOS may also issue one of the following beep codes:

1 long and two short beeps - video configuration error

1 repetitive long beep - no memory detected

Terminal POST Errors

If a terminal type of error occurs, BIOS will shut down the system. Before doing so, BIOS will write the error to port 80h, attempt to initialize video and write the error in the top left corner of the screen. The following is a list of codes that may be written to port 80h.

POST Code Description

01h	IPMI Initialization
02h	Verify Real Mode
03h	Disable Non-Maskable Interrupt (NMI)
04h	Get CPU type
06h	Initialize system hardware
07h	Disable shadow and execute code from the ROM.
08h	Initialize chipset with initial POST values
09h	Set IN POST flag
0Ah	Initialize CPU registers
0Bh	Enable CPU cache
0Ch	Initialize caches to initial POST values
0Eh	Initialize I/O component
0Fh	Initialize the local bus IDE
10h	Initialize Power Management
11h	Load alternate registers with initial POST values
12h	Restore CPU control word during warm boot
13h	Reset PCI Bus Mastering devices
14h	Initialize keyboard controller

POST Code	Description
16h	1-2-2-3 BIOS ROM checksum
17h	Initialize cache before memory Auto size
18h	8254 timer initialization
1Ah	8237 DMA controller initialization
1Ch	Reset Programmable Interrupt Controller
20h	1-3-1-1 Test DRAM refresh
22h	1-3-1-3 Test 8742 Keyboard Controller
24h	Set ES segment register to 4 GB
28h	Auto size DRAM
29h	Initialize POST Memory Manager
2Ah	Clear 512 kB base RAM
2Ch	1-3-4-1 RAM failure on address line xxxx*
2Eh	1-3-4-3 RAM failure on data bits xxxx* of low byte of memory bus
2Fh	Enable cache before system BIOS shadow
32h	Test CPU bus-clock frequency
33h	Initialize Phoenix Dispatch Manager
36h	Warm start shut down
38h	Shadow system BIOS ROM
3Ah	Auto size cache
3Ch	Advanced configuration of chipset registers
3Dh	Load alternate registers with CMOS values
41h	Initialize extended memory for RomPilot (optional)
42h	Initialize interrupt vectors
45h	POST device initialization
46h	2-1-2-3 Check ROM copyright notice
48h	Check video configuration against CMOS
49h	Initialize PCI bus and devices
4Ah	Initialize all video adapters in system
4Bh	QuietBoot start (optional)
4Ch	Shadow video BIOS ROM
4Eh	Display BIOS copyright notice
4Fh	Initialize MultiBoot
50h	Display CPU type and speed
51h	Initialize EISA board (optional)
52h	Test keyboard
54h	Set key click if enabled
55h	Enable USB devices
58h	2-2-3-1 Test for unexpected interrupts
59h	Initialize POST display service
5Ah	Display prompt "Press <ESC> to enter SETUP"
5Bh	Disable CPU cache

POST Code	Description
5Ch	Test RAM between 512 and 640 kB
60h	Test extended memory
62h	Test extended memory address lines
64h	Jump to UserPatch1
66h	Configure advanced cache registers
67h	Initialize Multi Processor APIC
68h	Enable external and CPU caches
69h	Setup System Management Mode (SMM) area
6Ah	Display external L2 cache size
6Bh	Load custom defaults (optional)
6Ch	Display shadow-area message
70h	Display error messages
72h	Check for configuration errors
76h	Check for keyboard errors
7Ch	Set up hardware interrupt vectors
7Dh	Initialize Intelligent System Monitoring (optional)
7Eh	Initialize coprocessor if present
80h	Disable onboard Super I/O ports and IRQs (optional)
81h	Late POST device initialization
82h	Detect and install external RS232 ports
83h	Configure non-MCD IDE controllers
84h	Detect and install external parallel ports
85h	Initialize PC-compatible PnP ISA devices
86h	Re-initialize onboard I/O ports.
87h	Configure Motherboard Configurable Devices (optional)
88h	Initialize BIOS Data Area
89h	Enable Non-Maskable Interrupts (NMIs)
8Ah	Initialize Extended BIOS Data Area
8Bh	Test and initialize PS/2 mouse
8Ch	Initialize floppy controller
8Fh	Determine number of ATA drives (optional)
90h	Initialize hard-disk controllers
91h	Initialize local-bus hard-disk controllers
92h	Jump to UserPatch2
93h	Build MPTABLE for multi-processor boards
95h	Install CD ROM for boot
96h	Clear huge ES segment register
97h	Fix up Multi Processor table
98h	1-2 Search for option ROMs and shadow if successful. One long, two short beeps on checksum failure

POST Code	Description
99h	Check for SMART Drive (optional)
9Ch	Set up Power Management
9Dh	Initialize security engine (optional)
9Eh	Enable hardware interrupts
9Fh	Determine number of ATA and SCSI drives
A0h	Set time of day
A2h	Check key lock
A4h	Initialize typematic rate
A8h	Erase <ESC> prompt
AAh	Scan for <ESC> key stroke
ACh	Enter SETUP
AEh	Clear Boot flag
B0h	Check for errors
B1h	Inform RomPilot about the end of POST (optional)
B2h	POST done - prepare to boot operating system
B4h	1 One short beep before boot
B5h	Terminate QuietBoot (optional)
B6h	Check password (optional)
B7h	Initialize ACPI BIOS and PPM Structures
B9h	Prepare Boot
BAh	Initialize SMBIOS
BCh	Clear parity checkers
BDh	Display MultiBoot menu
BEh	Clear screen (optional)
BFh	Check virus and backup reminders
C0h	Try to boot with INT 19
C1h	Initialize POST Error Manager (PEM)
C2h	Initialize error logging
C3h	Initialize error display function
C4h	Initialize system error flags
C6h	Console redirection init.
C7h	Unhook INT 10h if console redirection enabled
C8h	Force check (optional)
C9h	Extended ROM checksum (optional)
CDh	Reclaim console redirection vector
D2h	Unknown interrupt
D4h	Check Intel Branding string
D8h	Alert Standard Format initialization
D9h	Late init for IPMI
DEh	Log error if micro-code not updated properly

POST Code Description

D2h	Unknown interrupt
D4h	Check Intel Branding string
D8h	Alert Standard Format initialization
D9h	Late init for IPMI
DEh	Log error if micro-code not updated properly

The following are for boot block in Flash ROM**POST Code Description**

E0h	Initialize the chipset
E1h	Initialize the bridge
E2h	Initialize the CPU
E3h	Initialize system timer
E4h	Initialize system I/O
E5h	Check force recovery boot
E6h	Checksum BIOS ROM
E7h	Go to BIOS
E8h	Set Huge Segment
E9h	Initialize Multi Processor
EAh	Initialize OEM special code
EBh	Initialize PIC and DMA
ECh	Initialize Memory type
EDh	Initialize Memory size
EEh	Shadow Boot Block
EFh	System memory test
F0h	Initialize interrupt vectors
F1h	Initialize Run Time Clock
F2h	Initialize video
F3h	Initialize System Management Manager
F4h	Output one beep
F5h	Clear Huge Segment
F6h	Boot to Mini DOS
F7h	Boot to Full DOS

*If the BIOS detects error 2C, 2E, or 30 (base 512K RAM error), it displays an additional word-bitmap (**xxxx**) indicating the address line or bits that failed. For example, "2C 0002" means address line 1 (bit one set) has failed. "2E 1020" means data bits 12 and 5 (bits 12 and 5 set) have failed in the lower 16 bits. The BIOS also sends the bitmap to the port-80 LED display. It first displays the checkpoint code, followed by a delay, the high-order byte, another delay, and then the loworder byte of the error. It repeats this sequence continuously.

Notes

Appendix C

System Specifications

Processors

Single or dual Intel® Xeon® 5400/5300LV/5200/5100LV Sequence processors at a front side (system) bus speed of 1600/1333/1066 MHz.

Note: Please refer to our web site for a complete listing of supported processors.

Chipset

Intel 5400/ESB2 chipset

BIOS

8 Mb Phoenix® Flash ROM

Memory Capacity

Eight 240-pin DIMM sockets supporting up to 64 GB of ECC FBD DDR2-800/667/533 SDRAM.

See the memory section in Chapter 5 for details.

SATA Controller

Intel ESB2 on-chip controller for six-port Serial ATA (RAID 0, 1 5 and 10 supported)

SATA Drive Bays

6015W-NTR/6015W-NT:

Four (4) hot-swap drive bays to house four (4) SATA drives

6015W-UR/6015W-U:

Four (4) hot-swap drive bays to house four (4) SAS/SATA drives (with optional UIO SAS controller card)

Peripheral Drive Bays

One (1) slim floppy drive (optional)

One (1) slim DVD-ROM drive

Expansion Slots (see Section 5-6 for details)

6015W-UR/6015W-U:

Right side: one PCI-E x8 card (maximum length of 5.5")

Left side: a UIO card and one PCI-E x8 card

6015W-NTR/6015W-NT:

Right side: one PCI-E x8 card (maximum length of 5.5")

Left side: two PCI-E x8 cards

Serverboard

X7DWU (Extended ATX form factor)

Dimensions: 12 x 13.05 in (305 x 331 mm)

Chassis

6015W-UR/6015W-NTR: SC815TQ-R650U Form Factor: 1U rackmount

6015W-U/6015W-NT: SC815TQ-560U Form Factor: 1U rackmount

Dimensions: (WxHxD) 17 x 1.7 x 25.6 in. (432 x 43 x 650 mm)

Weight

6015W-UR/6015W-NTR: Gross (Bare Bone): 43 lbs. (19.5 kg.)

6015W-U/6015W-NT: Gross (Bare Bone): 41 lbs. (18.6 kg.)

System Cooling

Four (4) 4-cm heavy-duty counter-rotating fans

System Input Requirements

AC Input Voltage: 100-240 VAC

Rated Input Current: 8A (115V) to 4A (230V)

Rated Input Frequency: 50-60 Hz

Power Supply

6015W-UR/6015W-NTR

Rated Output Power: 650W (Model# PWS-651-1R)

Rated Output Voltages: +5V (25A), +3.3V (12A), +12V (54A), +5Vsb (3A)

6015W-U/6015W-NT

Rated Output Power: 560W (Model# PWS-561-1H20)

Rated Output Voltages: +5V (25A), +3.3V (21A), +12V (43.6A), -12V (0.6A), +5Vsb (3A)

Operating Environment

Operating Temperature: 10° to 35° C (50° to 95° F)

Non-operating Temperature: -40° to 70° C (-40° to 158° F)

Operating Relative Humidity: 8% to 90% (non-condensing)

Non-operating Relative Humidity: 5 to 95% (non-condensing)

Regulatory Compliance

Electromagnetic Emissions:

FCC Class A, EN 55022 Class A, EN 61000-3-2/-3-3, CISPR 22 Class A

Electromagnetic Immunity: EN 55024/CISPR 24, (EN 61000-4-2, EN 61000-4-3, EN 61000-4-4, EN 61000-4-5, EN 61000-4-6, EN 61000-4-8, EN 61000-4-11)

Safety: CSA/EN/IEC/UL 60950-1 Compliant, UL or CSA Listed (USA and Canada), CE Marking (Europe)

California Best Management Practices Regulations for Perchlorate Materials:
This Perchlorate warning applies only to products containing CR (Manganese Dioxide) Lithium coin cells. "Perchlorate Material-special handling may apply. See www.dtsc.ca.gov/hazardouswaste/perchlorate"

(continued from front)

The products sold by Supermicro are not intended for and will not be used in life support systems, medical equipment, nuclear facilities or systems, aircraft, aircraft devices, aircraft/emergency communication devices or other critical systems whose failure to perform be reasonably expected to result in significant injury or loss of life or catastrophic property damage. Accordingly, Supermicro disclaims any and all liability, and should buyer use or sell such products for use in such ultra-hazardous applications, it does so entirely at its own risk. Furthermore, buyer agrees to fully indemnify, defend and hold Supermicro harmless for and against any and all claims, demands, actions, litigation, and proceedings of any kind arising out of or related to such ultra-hazardous use or sale.