

SUPERO®

AS1021M-UR+

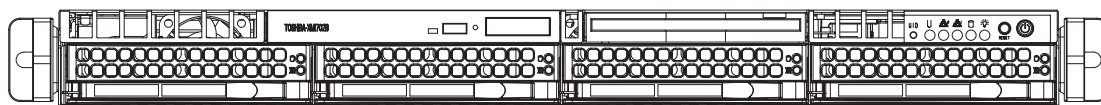

USER'S MANUAL

1.0a

The information in this User's Manual has been carefully reviewed and is believed to be accurate. The vendor assumes no responsibility for any inaccuracies that may be contained in this document, makes no commitment to update or to keep current the information in this manual, or to notify any person or organization of the updates. **Please Note: For the most up-to-date version of this manual, please see our web site at www.supermicro.com.**

Super Micro Computer, Inc. reserves the right to make changes to the product described in this manual at any time and without notice. This product, including software, if any, and documentation may not, in whole or in part, be copied, photocopied, reproduced, translated or reduced to any medium or machine without prior written consent.

IN NO EVENT WILL SUPERMICRO BE LIABLE FOR DIRECT, INDIRECT, SPECIAL, INCIDENTAL, SPECULATIVE OR CONSEQUENTIAL DAMAGES ARISING FROM THE USE OR INABILITY TO USE THIS PRODUCT OR DOCUMENTATION, EVEN IF ADVISED OF THE POSSIBILITY OF SUCH DAMAGES. IN PARTICULAR, SUPERMICRO SHALL NOT HAVE LIABILITY FOR ANY HARDWARE, SOFTWARE, OR DATA STORED OR USED WITH THE PRODUCT, INCLUDING THE COSTS OF REPAIRING, REPLACING, INTEGRATING, INSTALLING OR RECOVERING SUCH HARDWARE, SOFTWARE, OR DATA.

Any disputes arising between manufacturer and customer shall be governed by the laws of Santa Clara County in the State of California, USA. The State of California, County of Santa Clara shall be the exclusive venue for the resolution of any such disputes. Supermicro's total liability for all claims will not exceed the price paid for the hardware product.

FCC Statement: This equipment has been tested and found to comply with the limits for a Class A digital device pursuant to Part 15 of the FCC Rules. These limits are designed to provide reasonable protection against harmful interference when the equipment is operated in a commercial environment. This equipment generates, uses, and can radiate radio frequency energy and, if not installed and used in accordance with the manufacturer's instruction manual, may cause harmful interference with radio communications. Operation of this equipment in a residential area is likely to cause harmful interference, in which case you will be required to correct the interference at your own expense.

WARNING: Handling of lead solder materials used in this product may expose you to lead, a chemical known to the State of California to cause birth defects and other reproductive harm.

Manual Revision 1.0a

Release Date: September 4, 2007

Unless you request and receive written permission from Super Micro Computer, Inc., you may not copy any part of this document.

Information in this document is subject to change without notice. Other products and companies referred to herein are trademarks or registered trademarks of their respective companies or mark holders.

Copyright © 2007 by Super Micro Computer, Inc.
All rights reserved.

Printed in the United States of America

Preface

About This Manual

This manual is written for professional system integrators and PC technicians. It provides information for the installation and use of the 1021M-UR+. Installation and maintenance should be performed by experienced technicians only.

The AS1021M-UR+ is a high-end server based on the SC815TQ-R650U 1U rack-mount chassis and the H8DMU+, a dual processor serverboard that supports single or dual AMD 64-bit Socket F, Opteron 2000 type processors and up to 64 GB of DDR2-667/533/400 registered ECC SDRAM.

Manual Organization

Chapter 1: Introduction

The first chapter provides a checklist of the main components included with the server system and describes the main features of the H8DMU+ serverboard and the SC815TQ-R650U chassis, which comprise the 1021M-UR+.

Chapter 2: Server Installation

This chapter describes the steps necessary to install the 1021M-UR+ into a rack and check out the server configuration prior to powering up the system. If your server was ordered without processor and memory components, this chapter will refer you to the appropriate sections of the manual for their installation.

Chapter 3: System Interface

Refer here for details on the system interface, which includes the functions and information provided by the control panel on the chassis as well as other LEDs located throughout the system.

Chapter 4: System Safety

You should thoroughly familiarize yourself with this chapter for a general overview of safety precautions that should be followed when installing and servicing the 1021M-UR+.

Chapter 5: Advanced Serverboard Setup

Chapter 5 provides detailed information on the H8DMU+ serverboard, including the locations and functions of connections, headers and jumpers. Refer to this chapter when adding or removing processors or main memory and when reconfiguring the serverboard.

Chapter 6: Advanced Chassis Setup

Refer to Chapter 6 for detailed information on the SC815TQ-R650U server chassis. You should follow the procedures given in this chapter when installing, removing or reconfiguring SATA or peripheral drives and when replacing system power supply modules and cooling fans.

Chapter 7: BIOS

The BIOS chapter includes an introduction to BIOS and provides detailed information on running the CMOS Setup Utility.

Appendix A: BIOS Error Beep Codes

Appendix B: BIOS POST Checkpoint Codes

Appendix C: System Specifications

Notes

Table of Contents

Preface

About This Manual	iii
Manual Organization	iii

Chapter 1: Introduction

1-1 Overview	1-1
1-2 Serverboard Features	1-2
1-3 Server Chassis Features	1-3
1-4 Contacting Supermicro	1-6

Chapter 2: Server Installation

2-1 Overview	2-1
2-2 Unpacking the System	2-1
2-3 Preparing for Setup	2-1
Choosing a Setup Location	2-2
Rack Precautions	2-2
Server Precautions	2-2
Rack Mounting Considerations	2-3
2-4 Installing the System into a Rack	2-4
2-5 Checking the Serverboard Setup	2-8
2-6 Checking the Drive Bay Setup	2-10

Chapter 3: System Interface

3-1 Overview	3-1
3-2 Control Panel Buttons	3-1
UID	3-1
Reset	3-1
Power	3-1
3-3 Control Panel LEDs	3-2
Universal Information LED	3-2
NIC2	3-3
NIC1	3-3
HDD	3-3
Power	3-3
3-4 Drive Carrier LEDs	3-3

Chapter 4: System Safety

4-1	Electrical Safety Precautions	4-1
4-2	General Safety Precautions	4-2
4-3	ESD Precautions	4-3
4-4	Operating Precautions	4-4

Chapter 5: Advanced Serverboard Setup

5-1	Handling the Serverboard	5-1
5-2	Processor and Heatsink Installation	5-2
5-3	Connecting Cables	5-5
	Connecting Data Cables	5-5
	Connecting Power Cables	5-5
	Connecting the Control Panel	5-6
5-4	I/O Ports	5-7
5-5	Installing Memory	5-7
5-6	Adding PCI Cards	5-9
5-7	Serverboard Details	5-10
	H8DMU+ Layout	5-10
	H8DMU+ Quick Reference	5-11
5-8	Connector Definitions	5-12
	ATX Power Connector	5-12
	Processor Power Connector	5-12
	Auxiliary Power Connector	5-12
	Power LED	5-12
	HDD LED	5-13
	NIC1 LED	5-13
	NIC2 LED	5-13
	Overheat/Fan Fail/Power Fail/UID LED	5-13
	Power Fail LED	5-14
	Reset Button	5-14
	Power Button	5-14
	Universal Serial Bus (USB0/1)	5-14
	USB Headers	5-15
	Serial Ports	5-15
	Fan Headers	5-15
	LAN1/2 (Ethernet Ports)	5-15
	Power LED/Speaker	5-16
	ATX PS/2 Keyboard and PS/2 Mouse Ports	5-16
	Overheat LED	5-16

Chassis Intrusion	5-16
Wake-On-LAN	5-17
Wake-On-Ring	5-17
Power Supply I ² C Header	5-17
SMBus Header	5-17
Power Fail Alarm Reset Header	5-18
Compact Flash Power	5-18
SGPIO	5-18
UID Button	5-18
5-9 Jumper Settings	5-19
Explanation of Jumpers	5-19
CMOS Clear	5-19
VGA Enable/Disable	5-20
Watch Dog Enable/Disable	5-20
Onboard Speaker Enable/Disable	5-20
Compact Flash Master/Slave	5-21
I ² C to PCI-Express Enable/Disable	5-21
5-10 Onboard Indicators	5-22
LAN1/2 LEDs	5-22
+3.3V LED	5-22
UID LED	5-22
5-11 Floppy, IDE and SATA Drive Connections	5-23
Floppy Connector	5-23
IDE Connector	5-24
SATA Ports	5-24
5-12 Enabling SATA RAID	5-25
5-13 Installing Drivers	5-28

Chapter 6: Advanced Chassis Setup

6-1 Static-Sensitive Devices	6-1
6-2 Control Panel	6-2
6-3 System Fans	6-3
System Fan Failure	6-3
Replacing System Fans	6-3
6-4 Drive Bay Installation/Removal	6-4
6-5 Power Supply	6-9
Power Supply Failure	6-9
Removing/Replacing the Power Supply	6-9

Chapter 7: BIOS

7-1	Introduction	7-1
7-2	Main Menu	7-2
7-3	Advanced Settings Menu	7-2
7-4	Boot Menu	7-16
7-5	Security Menu	7-17
7-6	Exit Menu	7-18

Appendices:

Appendix A: BIOS Error Beep Codes

Appendix B: BIOS POST Checkpoint Codes

Appendix C: System Specifications

Notes

Chapter 1

Introduction

1-1 Overview

The AS1021M-UR+ is a high-end server comprised of two main subsystems: the SC815TQ-R650U 1U server chassis and the H8DMU+ dual processor serverboard. Please refer to our web site for information on operating systems that have been certified for use with the system (www.supermicro.com).

In addition to the serverboard and chassis, various hardware components have been included with the 1021M-UR+, as listed below:

- One (1) slim DVD-ROM drive [DVM-PNSC-824(B)]
- Four (4) sets of 4-cm counter-rotating fans (FAN-0086L)
- One (1) air shroud (MCP-310-00026-01)
- Two (2) passive CPU heatsinks (SNK-P0022)
- Riser Cards: (see Section 5-6 for details)
One (1) CSE-R1UU-UE8 for PCI-E card
- SATA Accessories
One (1) SAS/SATA backplane (BPN-SAS-815TQ)
One (1) SATA iPASS cable (CBL-0188L)
Four (4) SATA/SAS drive carriers (MCP-220-00001-03)
- One (1) rackmount kit (CSE-PT51L)
- One (1) CD containing drivers and utilities

Note: a "V" at the end of a server name indicates the chassis is silver.

1-2 Serverboard Features

At the heart of the AS1021M-UR+ lies the H8DMU+, a dual processor serverboard based the nVidia MCP55 Pro chipset. Below are the main features of the H8DMU+ (see Figure 1-1 for a block diagram of the chipset).

Processors

The H8DMU+ supports single or dual AMD 64-bit Socket F, Opteron 2000 type processors. Please refer to the serverboard description pages on our web site for a complete listing of supported processors.

Memory

The H8DMU+ has sixteen dual/single channel DIMM slots supporting up to 64 GB of DDR2-667/533/400 registered ECC SDRAM. Please refer to Chapter 5 for memory speed jumper settings.

UIO

The H8DMU+ is a specially-designed serverboard that features Supermicro's UIO (Universal I/O) technology. UIO serverboards have a PCI-Express x8 connector that can support any one of several types of UIO card types to add SAS ports, additional LAN ports, etc. to the serverboard. This allows the user to tailor the serverboard to their own needs.

Serial ATA

An on-chip SATA controller is integrated into the H8DMU+ to provide a six-port, 3 Gb/sec Serial ATA subsystem, which is RAID 0, 1, 0+1, 5 and JBOD supported. The SATA drives are hot-swappable units. **Note:** The operating system you use must have RAID support to enable the hot-swap capability and RAID function of the Serial ATA drives.

Onboard Controllers/Ports

One floppy drive controller and one onboard ATA/133 controller are provided to support up to two IDE hard drives or ATAPI devices. The color-coded I/O ports include one COM port, a VGA (monitor) port, two USB 2.0 ports, PS/2 mouse and keyboard ports and two gigabit Ethernet ports.

ATI Graphics Controller

The H8DMU+ features an integrated ATI video controller based on the ES1000 graphics chip. The ES1000 was designed specifically for servers, featuring low power consumption, high reliability and superior longevity.

Other Features

Other onboard features that promote system health include onboard voltage monitors, a chassis intrusion header, auto-switching voltage regulators, chassis and CPU overheat sensors, virus protection and BIOS rescue.

1-3 Server Chassis Features

The 1021M-UR+ is built upon the SC815TQ-R650U. The following is a general outline of the main features of the chassis.

System Power

The SC815TQ-R650U features a redundant 650W power supply consisting of two power modules. The system does not need to be shut down when replacing or removing a single power supply module.

SAS/SATA Subsystem

The SC815TQ-R650U chassis was designed to support four hot-swap SAS/SATA hard drives.

PCI Expansion Slots

The chassis can support a UIO card and one PCI-E x8 card.

Front Control Panel

The chassis' control panel provides you with system monitoring and control. LEDs indicate system power, HDD activity, network activity (two) and UID/overheat/fan fail/power fail. A main power button and system reset button is also included.

I/O Backplane

The SC815TQ-R650U is an extended ATX form factor chassis that is designed to be used in a 1U rackmount configuration. Ports on the I/O backplane include one COM port, a VGA port, two USB 2.0 ports, PS/2 mouse and keyboard ports and two gigabit Ethernet ports. A UID (Unit Identifier) button and LED are also located beside the LAN2 Ethernet port.

Cooling System

The SC815TQ-R650U chassis has an innovative cooling design that features four sets of 4-cm counter-rotating fans located in the middle section of the chassis. There is a "Fan Speed Control Mode" setting in BIOS that allows chassis fan speed to be determined by system temperature. The power supply module also includes a cooling fan.

**Figure 1-1. nVidia MCP55 Pro Chipset:
System Block Diagram**

Note: This is a general block diagram. Please see Chapter 5 for details.

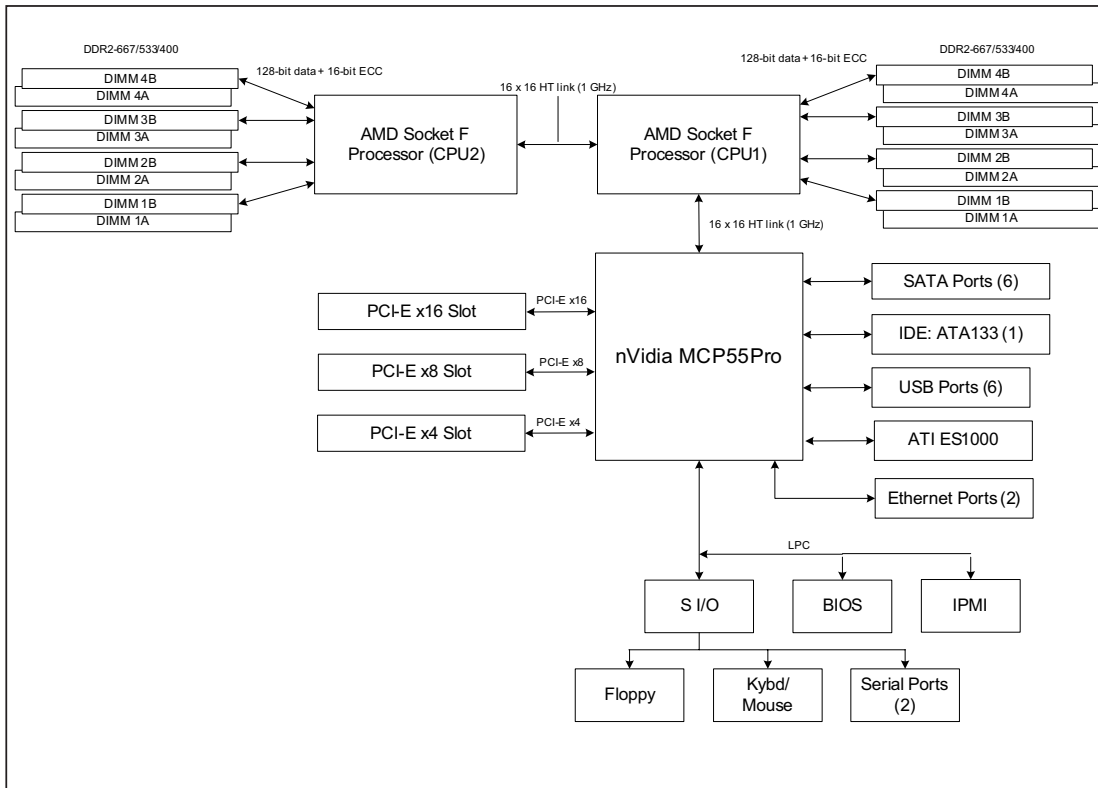

1-4 Contacting Supermicro

Headquarters

Address: SuperMicro Computer, Inc.
980 Rock Ave.
San Jose, CA 95131 U.S.A.

Tel: +1 (408) 503-8000

Fax: +1 (408) 503-8008

Email: marketing@supermicro.com (General Information)
support@supermicro.com (Technical Support)

Web Site: www.supermicro.com

Europe

Address: SuperMicro Computer B.V.
Het Sterrenbeeld 28, 5215 ML
's-Hertogenbosch, The Netherlands

Tel: +31 (0) 73-6400390

Fax: +31 (0) 73-6416525

Email: sales@supermicro.nl (General Information)
support@supermicro.nl (Technical Support)
rma@supermicro.nl (Customer Support)

Asia-Pacific

Address: SuperMicro, Taiwan
4F, No. 232-1, Liancheng Rd.
Chung-Ho 235, Taipei County
Taiwan, R.O.C.

Tel: +886-(2) 8226-3990

Fax: +886-(2) 8226-3991

Web Site: www.supermicro.com.tw

Technical Support:

Email: support@supermicro.com.tw

Tel: 886-2-8228-1366, ext.132 or 139

Chapter 2

Server Installation

2-1 Overview

This chapter provides a quick setup checklist to get your 1021M-UR+ up and running. Following these steps in the order given should enable you to have the system operational within a minimum amount of time. This quick setup assumes that your system has come to you with the processors and memory preinstalled. If your system is not already fully integrated with a serverboard, processors, system memory etc., please turn to the chapter or section noted in each step for details on installing specific components.

2-2 Unpacking the System

You should inspect the box the 1021M-UR+ was shipped in and note if it was damaged in any way. If the server itself shows damage you should file a damage claim with the carrier who delivered it.

Decide on a suitable location for the rack unit that will hold the 1021M-UR+. It should be situated in a clean, dust-free area that is well ventilated. Avoid areas where heat, electrical noise and electromagnetic fields are generated. You will also need it placed near a grounded power outlet. Be sure to read the Rack and Server Precautions in the next section.

2-3 Preparing for Setup

The box the 1021M-UR+ was shipped in should include two sets of rail assemblies, two rail mounting brackets and the mounting screws you will need to install the system into the rack. Follow the steps in the order given to complete the installation process in a minimum amount of time. Please read this section in its entirety before you begin the installation procedure outlined in the sections that follow.

Choosing a Setup Location

- Leave enough clearance in front of the rack to enable you to open the front door completely (~25 inches).
- Leave approximately 30 inches of clearance in the back of the rack to allow for sufficient airflow and ease in servicing.
- This product is for installation only in a Restricted Access Location (dedicated equipment rooms, service closets and the like).
- This product is not suitable for use with visual display work place devices according to §2 of the the German Ordinance for Work with Visual Display Units.



Warnings and Precautions!



Rack Precautions

- Ensure that the leveling jacks on the bottom of the rack are fully extended to the floor with the full weight of the rack resting on them.
- In single rack installation, stabilizers should be attached to the rack.
- In multiple rack installations, the racks should be coupled together.
- Always make sure the rack is stable before extending a component from the rack.
- You should extend only one component at a time - extending two or more simultaneously may cause the rack to become unstable.

Server Precautions

- Review the electrical and general safety precautions in Chapter 4.
- Determine the placement of each component in the rack *before* you install the rails.
- Install the heaviest server components on the bottom of the rack first, and then work up.
- Use a regulating uninterruptible power supply (UPS) to protect the server from power surges, voltage spikes and to keep your system operating in case of a power failure.
- Allow the hot plug SAS/SATA drives and power supply modules to cool before touching them.
- Always keep the rack's front door and all panels and components on the servers closed when not servicing to maintain proper cooling.

Rack Mounting Considerations

Ambient Operating Temperature

If installed in a closed or multi-unit rack assembly, the ambient operating temperature of the rack environment may be greater than the ambient temperature of the room. Therefore, consideration should be given to installing the equipment in an environment compatible with the manufacturer's maximum rated ambient temperature (T_{mra}).

Reduced Airflow

Equipment should be mounted into a rack so that the amount of airflow required for safe operation is not compromised.

Mechanical Loading

Equipment should be mounted into a rack so that a hazardous condition does not arise due to uneven mechanical loading.

Circuit Overloading

Consideration should be given to the connection of the equipment to the power supply circuitry and the effect that any possible overloading of circuits might have on overcurrent protection and power supply wiring. Appropriate consideration of equipment nameplate ratings should be used when addressing this concern.

Reliable Ground

A reliable ground must be maintained at all times. To ensure this, the rack itself should be grounded. Particular attention should be given to power supply connections other than the direct connections to the branch circuit (i.e. the use of power strips, etc.).

2-4 Installing the System into a Rack

This section provides information on installing the 1021M-UR+ into a rack unit with the rack rails provided. If the system has already been mounted into a rack, you can skip ahead to Sections 2-5 and 2-6. There are a variety of rack units on the market, which may mean the assembly procedure will differ slightly. You should also refer to the installation instructions that came with the rack unit you are using.

Identifying the Sections of the Rack Rails

You should have received two rack rail assemblies in the rack mounting kit. Each assembly consists of two sections: an inner fixed chassis rail that secures directly to the server chassis and an outer fixed rack rail that secures directly to the rack itself (see Figure 2-1). Two pairs of short brackets to be used on the front side of the outer rails are also included.

Installing the Inner Rails

Both the left and right side inner rails have been pre-attached to the chassis. Proceed to the next step.

**Figure 2-1. Identifying the Sections of the Rack Rails
(right side rail shown)**

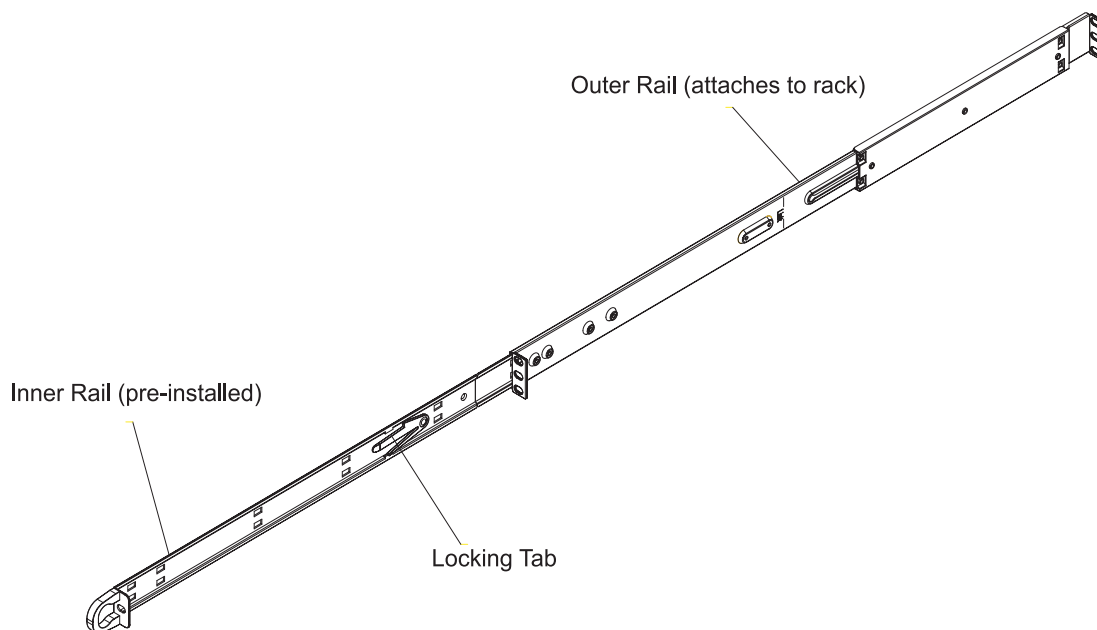

Installing the Outer Rails

Begin by measuring the distance from the front rail to the rear rail of the rack. Attach a short bracket to the front side of the right outer rail and a long bracket to the rear side of the right outer rail. Adjust both the short and long brackets to the proper distance so that the rail can fit snugly into the rack. Secure the short bracket to the front side of the outer rail with two screws and the long bracket to the rear side of the outer rail with three screws. Repeat these steps for the left outer rail.

Locking Tabs

Both chassis rails have a locking tab, which serves two functions. The first is to lock the server into place when installed and pushed fully into the rack, which is its normal position. Secondly, these tabs also lock the server in place when fully extended from the rack. This prevents the server from coming completely out of the rack when you pull it out for servicing.

Figure 2-2. Installing the Rack Rails

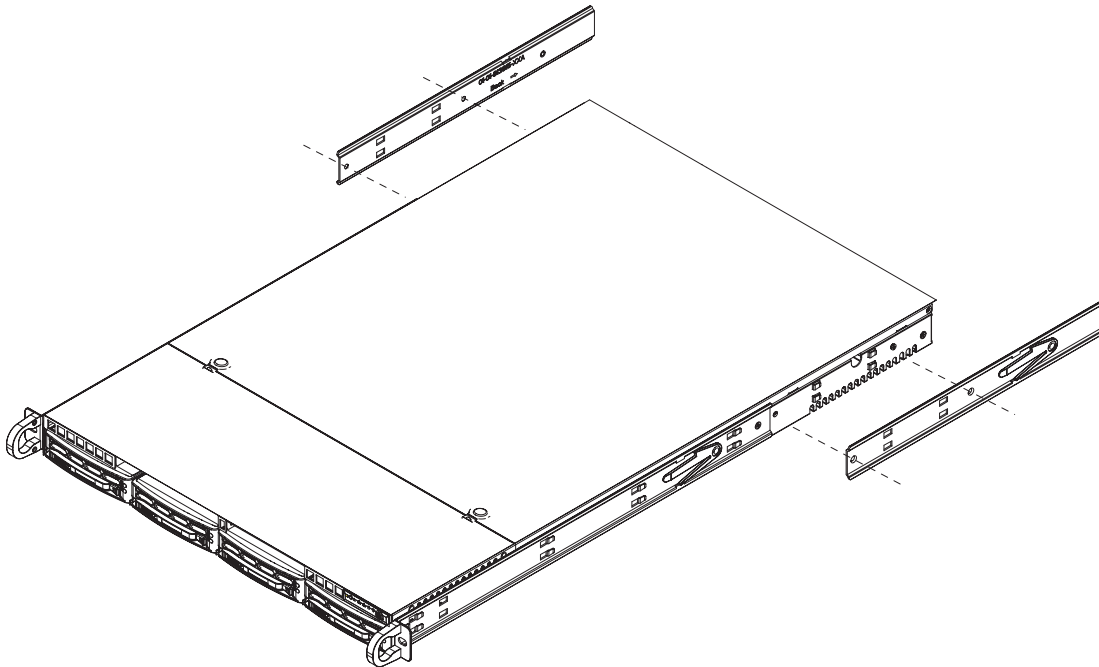

Installing the Server into the Rack

You should now have rails attached to both the chassis and the rack unit. The next step is to install the server into the rack. Do this by lining up the rear of the chassis rails with the front of the rack rails. Slide the chassis rails into the rack rails, keeping the pressure even on both sides (you may have to depress the locking tabs when inserting). See Figure 2-3.

When the server has been pushed completely into the rack, you should hear the locking tabs "click". Finish by inserting and tightening the thumbscrews that hold the front of the server to the rack.

Figure 2-3. Installing the Server into a Rack

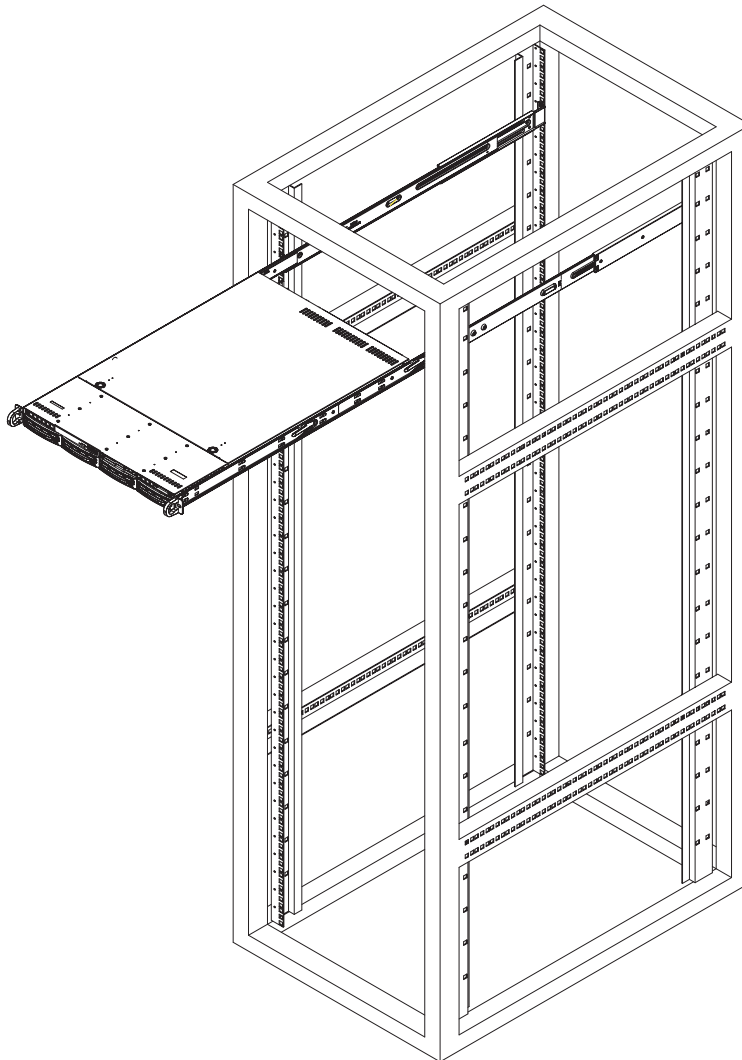

Installing the Server into a Telco Rack

Telco racks utilize two posts instead of four. Because of this, telco racks require a different installation process

1. Install the inner rails to the chassis as described in this chapter.
2. Place the chassis (with inner rails) in the rack. A second individual may be required to hold the chassis in place.
3. Secure the outer rails to the Telco rack as illustrated.
4. Test the installation by pulling the chassis in and out of the rack.

Figure 2-4. Installing the Server into a Telco Rack

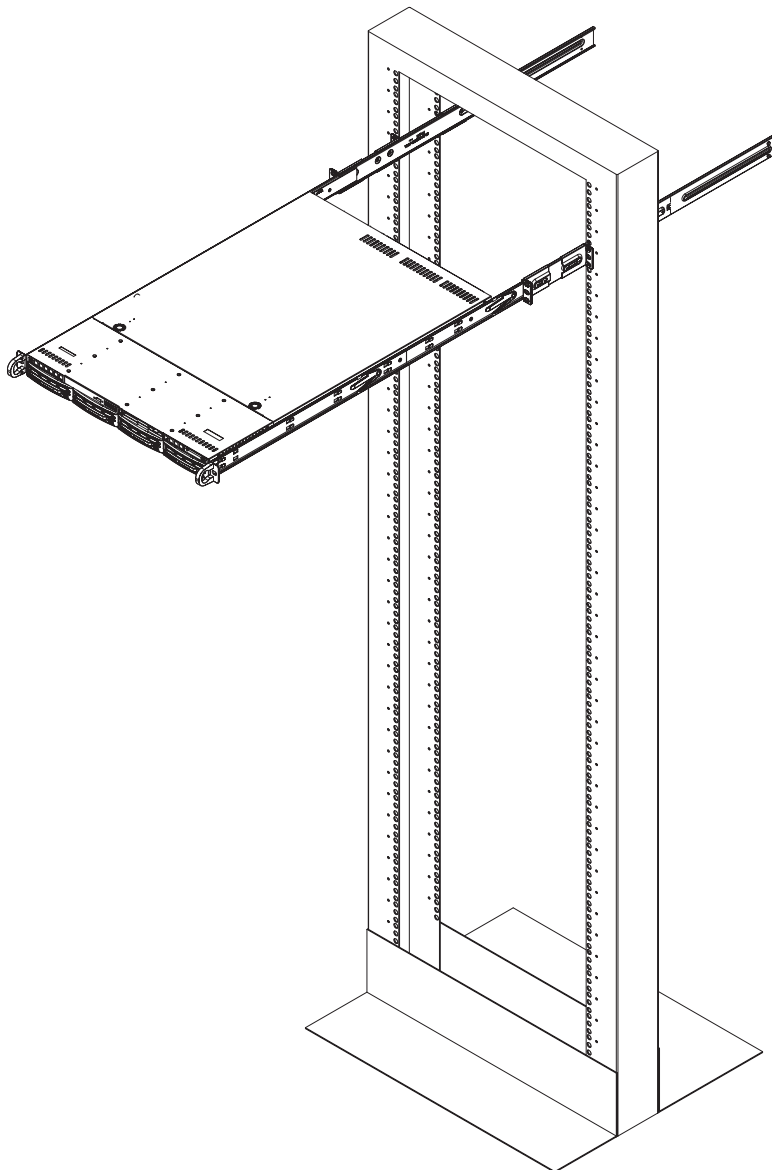

2-5 Checking the Serverboard Setup

After you install the 1021M-UR+ in the rack, you will need to open the top cover to make sure the serverboard is properly installed and all the connections have been made.

1. Accessing the inside of the System (see Figure 2-5)

First, grasp the two handles on either side and pull the system straight out until it locks (you will hear a "click"). Next, depress the two buttons on the top of the chassis to release the top cover (1). Push the cover away from you (toward the rear of the chassis) until it stops (2). You can then lift the top cover from the chassis to gain full access to the inside of the server.

To remove the system from the rack completely, depress the locking tabs in the chassis rails (push the right-side tab down and the left-side tab up) to continue to pull the system out past the locked position.

2. Check the CPUs (processors)

You may have one or two processors already installed in the serverboard. Each processor needs its own heatsink. See Chapter 5 for instructions on processor and heatsink installation.

3. Check the system memory

Your server system may have come with system memory already installed. Make sure all DIMMs are fully seated in their slots. For details on adding system memory, refer to Chapter 5.

4. Installing add-on cards

If desired, you can install add-on cards to the system. See Chapter 5 for details on installing PCI add-on cards.

5. Check all cable connections and airflow

Make sure all power and data cables are properly connected and not blocking the chassis airflow. See Chapter 5 for details on cable connections.

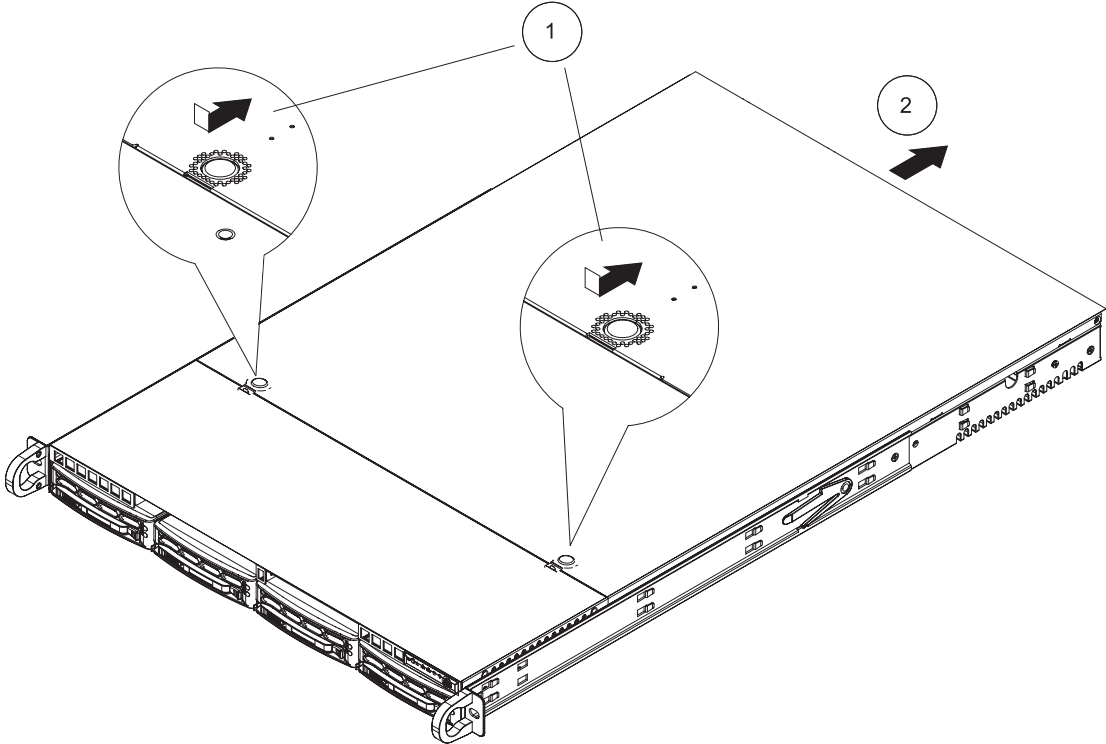

Figure 2-5. Accessing the Inside of the System

2-6 Checking the Drive Bay Setup

Next, you should check to make sure the peripheral drives and the SAS/SATA drives and SAS/SATA backplane have been properly installed and all connections have been made.

1. Accessing the drive bays

All drives are accessible from the front of the server. For servicing the DVD-ROM and floppy drives, you will need to remove the top chassis cover. The SAS/SATA disk drives can be installed and removed from the front of the chassis without removing the top chassis cover.

2. DVD-ROM and floppy disk drives

A slim DVD-ROM and floppy drive should be preinstalled in your server. Refer to Chapter 6 if you need to reinstall a DVD-ROM and/or floppy disk drive to the system.

3. Check the SATA disk drives

Depending upon your system's configuration, your system may have one or more drives already installed. If you need to install SAS/SATA drives, please refer to Chapter 6.

4. Check the airflow

Airflow is provided by four sets of 4-cm fans (each set of fans consists of two fans that are mounted back to back). The system component layout was carefully designed to direct sufficient cooling airflow to the components that generate the most heat. Note that all power and data cables have been routed in such a way that they do not block the airflow generated by the fans.

5. Supplying power to the system

The last thing you must do is to provide input power to the system. Plug the power cords from the power supply modules into a high-quality power strip that offers protection from electrical noise and power surges. It is recommended that you use an uninterruptible power supply (UPS) source.

Chapter 3

System Interface

3-1 Overview

There are several LEDs on the control panel as well as others on the SAS/SATA drive carriers to keep you constantly informed of the overall status of the system as well as the activity and health of specific components. There are also two buttons on the chassis control panel and an on/off switch on the power supply. This chapter explains the meanings of all LED indicators and the appropriate response you may need to take.

3-2 Control Panel Buttons

There are three push-buttons located on the front of the chassis: a reset button, a UID button and a power on/off button.

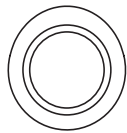

- **UID:** Depressing the UID (unit identifier) button illuminates an LED on both the front and rear of the chassis for easy system location in large stack configurations. The LED will remain on until the button is pushed a second time. Another UID button on the rear of the chassis serves the same function.

RESET

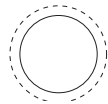

- **Reset:** Use the reset button to reboot the system.



- **Power:** The main power button is used to apply or remove power from the power supply to the server system. Turning off system power with this button removes the main power but keeps standby power supplied to the system.

3-3 Control Panel LEDs

The control panel located on the front of the SC815TQ-R650U chassis has five LEDs. These LEDs provide you with critical information related to different parts of the system. This section explains what each LED indicates when illuminated and any corrective action you may need to take.



- **Universal Information LED:** This LED can indicate any of four conditions. When this LED is red and blinks on and off quickly it indicates a fan failure. When blinking red slowly it indicates a power supply failure. When the LED blinks blue it serves as a UID indicator initiated via IPMI. If blue continuously it is a UID indicator initiated via the UID button. When red continuously it indicates an overheat condition, which may be caused by cables obstructing the airflow in the system or the ambient room temperature being too warm. Check the routing of the cables and make sure all fans are present and operating normally. You should also check to make sure that the chassis covers are installed. Finally, verify that the heatsinks are installed properly (see Chapter 5). This LED will remain blinking or on as long as the condition exists or UID is reinitiated.

Figure 3-1. Universal Information LED States

Universal Information LED States	
State	Indication
Fast Blinking Red (1x/sec)	Fan Fail
Solid Red	CPU Overheat
Slow Blinking Red (1x/4 sec)	Power Fail
Solid Blue	Local UID Button Depressed
Blinking Blue	IPMI-Activated UID

Note: deactivating the UID LED must be performed in the same way it was activated. (If the UID LED was activated via IPMI, you can only turn the LED off via IPMI and not with the UID button.)



- **NIC2:** Indicates network activity on LAN2 when flashing .



- **NIC1:** Indicates network activity on LAN1 when flashing.



- **HDD:** Indicates IDE channel activity. On the 1021M-UR+, this light indicates SAS/SATA and/or DVD-ROM drive activity when flashing.



- **Power:** Indicates power is being supplied to the system's power supply units. This LED should normally be illuminated when the system is operating.

3-4 Drive Carrier LEDs

Each Serial ATA drive carrier has two LEDs.

- **Green:** When illuminated, the green LED on the front of the SATA drive carrier indicates drive activity. A connection to the SATA backplane enables this LED to blink on and off when that particular drive is being accessed.
- **Red:** The red LED indicates two states. When blinking, it indicates the drive is rebuilding. When solid, it indicates a drive failure. If a SATA drive fails, you

should be notified by your system management software. Please refer to Chapter 6 for instructions on replacing failed SATA drives.

Each SAS drive carrier has two LEDs.

- **Green:** When illuminated, the green LED on the front of the SAS drive carrier indicates drive activity. A connection to the SAS backplane enables this LED to blink on and off when that particular drive is being accessed.
- **Red:** The 1021M-UR+ features a SES2 compliant backplane that activates the red LEDs, which indicate a drive failure. Please refer to Chapter 6 for instructions on replacing failed SAS drives.

Chapter 4

System Safety

4-1 Electrical Safety Precautions



Basic electrical safety precautions should be followed to protect yourself from harm and the system from damage:

- Be aware of the locations of the power on/off switch on the chassis as well as the room's emergency power-off switch, disconnection switch or electrical outlet. If an electrical accident occurs, you can then quickly remove power from the system.
- Do not work alone when working with high voltage components.
- Power should always be disconnected from the system when removing or installing main system components, such as the serverboard, memory modules and the DVD-ROM and floppy drives (not necessary for SATA drives). When disconnecting power, you should first power down the system with the operating system and then unplug the power cords from all the power supply modules in the system.
- When working around exposed electrical circuits, another person who is familiar with the power-off controls should be nearby to switch off the power if necessary.
- Use only one hand when working with powered-on electrical equipment. This is to avoid making a complete circuit, which will cause electrical shock. Use extreme caution when using metal tools, which can easily damage any electrical components or circuit boards they come into contact with.
- Do not use mats designed to decrease electrostatic discharge as protection from electrical shock. Instead, use rubber mats that have been specifically designed as electrical insulators.
- The power supply power cord must include a grounding plug and must be plugged into grounded electrical outlets.

- Serverboard Battery: **CAUTION** - There is a danger of explosion if the onboard battery is installed upside down, which will reverse its polarities (see Figure 4-1). This battery must be replaced only with the same or an equivalent type recommended by the manufacturer. Dispose of used batteries according to the manufacturer's instructions.
- DVD-ROM Laser: **CAUTION** - this server may have come equipped with a DVD-ROM drive. To prevent direct exposure to the laser beam and hazardous radiation exposure, do not open the enclosure or use the unit in any unconventional way.
- Mainboard replaceable soldered-in fuses: Self-resetting PTC (Positive Temperature Coefficient) fuses on the mainboard must be replaced by trained service technicians only. The new fuse must be the same or equivalent as the one replaced. Contact technical support for details and support.

4-2 General Safety Precautions



Follow these rules to ensure general safety:

- Keep the area around the 1021M-UR+ clean and free of clutter.
- The 1021M-UR+ weighs approximately 43 lbs (19.5 kg) when fully loaded. When lifting the system, two people at either end should lift slowly with their feet spread out to distribute the weight. Always keep your back straight and lift with your legs.
- Place the chassis top cover and any system components that have been removed away from the system or on a table so that they won't accidentally be stepped on.
- While working on the system, do not wear loose clothing such as neckties and unbuttoned shirt sleeves, which can come into contact with electrical circuits or be pulled into a cooling fan.
- Remove any jewelry or metal objects from your body, which are excellent metal conductors that can create short circuits and harm you if they come into contact with printed circuit boards or areas where power is present.

- After accessing the inside of the system, close the system back up and secure it to the rack unit with the retention screws after ensuring that all connections have been made.

4-3 ESD Precautions



Electrostatic discharge (ESD) is generated by two objects with different electrical charges coming into contact with each other. An electrical discharge is created to neutralize this difference, which can damage electronic components and printed circuit boards. The following measures are generally sufficient to neutralize this difference before contact is made to protect your equipment from ESD:

- Use a grounded wrist strap designed to prevent static discharge.
- Keep all components and printed circuit boards (PCBs) in their antistatic bags until ready for use.
- Touch a grounded metal object before removing any board from its antistatic bag.
- Do not let components or PCBs come into contact with your clothing, which may retain a charge even if you are wearing a wrist strap.
- Handle a board by its edges only; do not touch its components, peripheral chips, memory modules or contacts.
- When handling chips or modules, avoid touching their pins.
- Put the serverboard and peripherals back into their antistatic bags when not in use.
- For grounding purposes, make sure your computer chassis provides excellent conductivity between the power supply, the case, the mounting fasteners and the serverboard.

4-4 Operating Precautions



Care must be taken to assure that the chassis cover is in place when the 1021M-UR+ is operating to ensure proper cooling. Out of warranty damage to the 1021M-UR+ system can occur if this practice is not strictly followed.

Figure 4-1. Installing the Onboard Battery

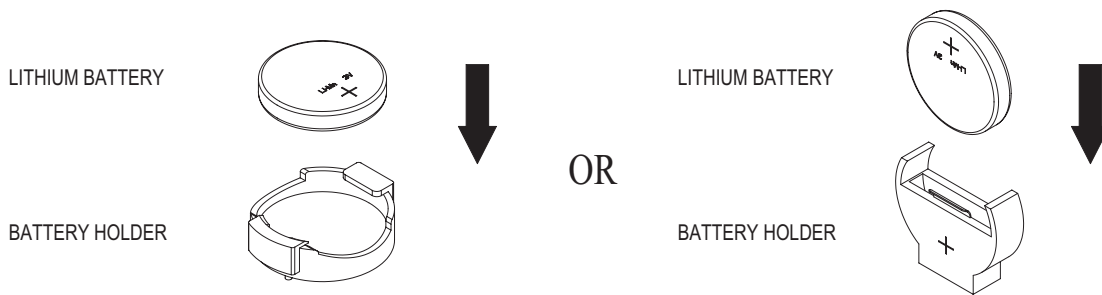

Chapter 5

Advanced Serverboard Setup

This chapter covers the steps required to install processors and heatsinks to the H8DMU+ serverboard, connect the data and power cables and install add-on cards. All serverboard jumpers and connections are described and a layout and quick reference chart are included in this chapter. Remember to close the chassis completely when you have finished working on the serverboard to protect and cool the system sufficiently.

5-1 Handling the Serverboard

Static electrical discharge can damage electronic components. To prevent damage to printed circuit boards, it is important to handle them very carefully (see Chapter 4). Also note that the size and weight of the serverboard can cause it to bend if handled improperly, which may result in damage. To prevent the serverboard from bending, keep one hand under the center of the board to support it when handling. The following measures are generally sufficient to protect your equipment from static discharge.

Precautions

- Use a grounded wrist strap designed to prevent static discharge.
- Touch a grounded metal object before removing any board from its antistatic bag.
- Handle a board by its edges only; do not touch its components, peripheral chips, memory modules or gold contacts.
- When handling chips or modules, avoid touching their pins.
- Put the serverboard, add-on cards and peripherals back into their antistatic bags when not in use.

Unpacking

The serverboard is shipped in antistatic packaging to avoid static damage. When unpacking the board, make sure the person handling it is static protected.

5-2 Processor and Heatsink Installation



Exercise extreme caution when handling and installing the processor. Always connect the power cord last and always remove it before adding, removing or changing any hardware components.

CPU Backplates

Two CPU backplates (BKT-0011L) have been preinstalled to the serverboard to prevent the CPU area of the serverboard from bending and to provide a base for attaching the heatsink retention modules.

Installing the Processor (install to the CPU#1 socket first)

1. Begin by removing the cover plate that protects the CPU. Lift the lever on CPU socket #1 until it points straight up. With the lever raised, lift open the silver CPU retention plate.

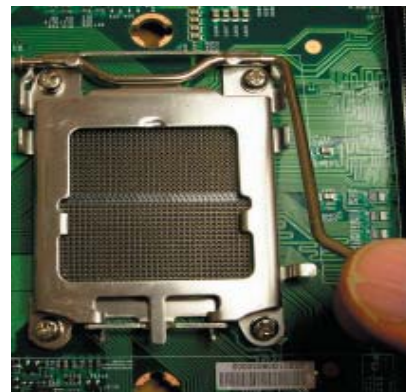

2. Use your thumb and your index finger to hold the CPU. Locate and align pin 1 of the CPU socket with pin 1 of the CPU. Both are marked with a triangle.

Triangles



3. Align pin 1 of the CPU with pin 1 of the socket. Once aligned, carefully place the CPU into the socket. *Do not drop the CPU on the socket, move the CPU horizontally or vertically or rub the CPU against the socket or against any pins of the socket, which may damage the CPU and/or the socket.*



4. With the CPU inserted into the socket, inspect the four corners of the CPU to make sure that it is properly installed and flush with the socket. Then, gently lower the silver CPU retention plate into place.



5. Carefully press the CPU socket lever down until it locks into its retention tab. For a dual-processor system, repeat these steps to install another CPU into the CPU#2 socket.

Note: if using a single processor, only the CPU1 DIMM slots are addressable for a maximum of 32 GB memory.



Installing the Heatsink Retention Modules

Two heatsink retention modules (BKT-0012L) and four screws are included in the retail box. Once installed, these are used to help attach the heatsinks to the CPUs. To install, align the module with the standoffs of the preinstalled CPU backplate and with the four feet on the module contacting the serverboard. Secure the retention module to the backplate with two of the screws provided. See Figure 2-1. Repeat for the second CPU socket.

Note: BKT-0012L is included for use with non-Supermicro heatsinks only. When installing Supermicro heatsinks, only BKT-0011L (the pre-installed CPU backplate) is needed. The BKT-0012L retention module was designed to provide compatibility with clip-and-cam type heatsinks from third parties.

Figure 2-1. CPU Heatsink Retention Module Installation

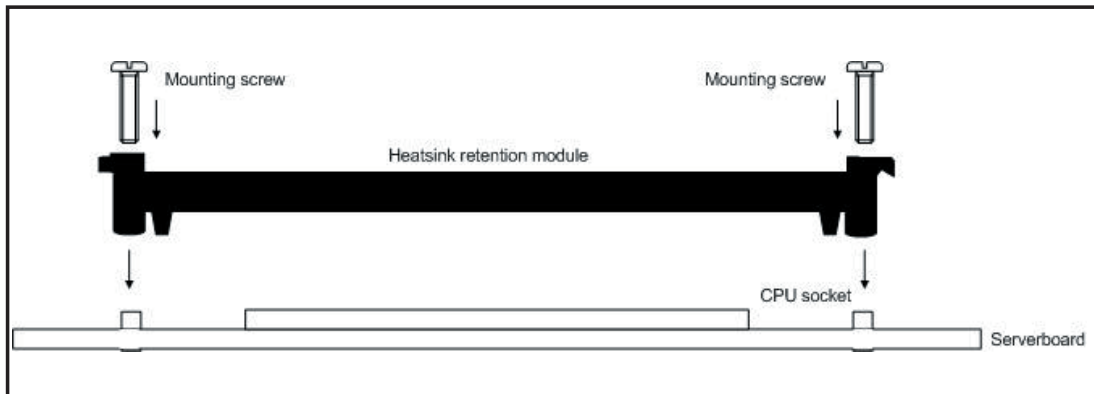

Installing the Heatsink

The use of active type heatsinks (except for 1U systems) are recommended. Connect the heatsink fans to the appropriate fan headers on the serverboard. To install the heatsinks, please follow the installation instructions included with your heatsink package (not included).

5-3 Connecting Cables

Now that the processors are installed, the next step is to connect the cables to the serverboard. These include the data (ribbon) cables for the peripherals and control panel and the power cables.

Connecting Data Cables

The ribbon cables used to transfer data from the peripheral devices have been carefully routed in preconfigured systems to prevent them from blocking the flow of cooling air that moves through the system from front to back. If you need to disconnect any of these cables, you should take care to reroute them as they were originally after reconnecting them (make sure the red wires connect to the pin 1 locations). If you are configuring the system, keep the airflow in mind when routing the cables. The following data cables (with their serverboard connector locations noted) should be connected. See the serverboard layout diagram in this chapter for connector locations.

- DVD-ROM Drive cable (IDE#1)
- Control Panel cable (JF1, see next page)
- SATA cables (SATA0 ~ SATA3)
- SGPIO cable (SGPIO1 to SATA backplane)

Connecting Power Cables

The H8DMU+ has a 20-pin primary power supply connector designated "JPW1" for connection to the ATX power supply. Connect the appropriate connector from the power supply to JPW1 to supply power to the serverboard. See the Connector Definitions section in this chapter for power connector pin definitions.

In addition, your power supply must be connected to the 4-pin Auxiliary ATX Power connection at J32 and the 8-pin Processor Power connector at JPW2.

Connecting the Control Panel

JF1 contains header pins for various front control panel connectors. See Figure 5-1 for the pin locations of the various front control panel buttons and LED indicators. Please note that even and odd numbered pins are on opposite sides of each header.

All JF1 wires have been bundled into single keyed ribbon cable to simplify their connection. The red wire in the ribbon cable plugs into pin 1 of JF1. Connect the other end of the cable to the Control Panel printed circuit board, located just behind the system status LEDs in the chassis.

See the Connector Definitions section in this chapter for details and pin descriptions of JF1.

Figure 5-1. Front Control Panel Header Pins (JF1)

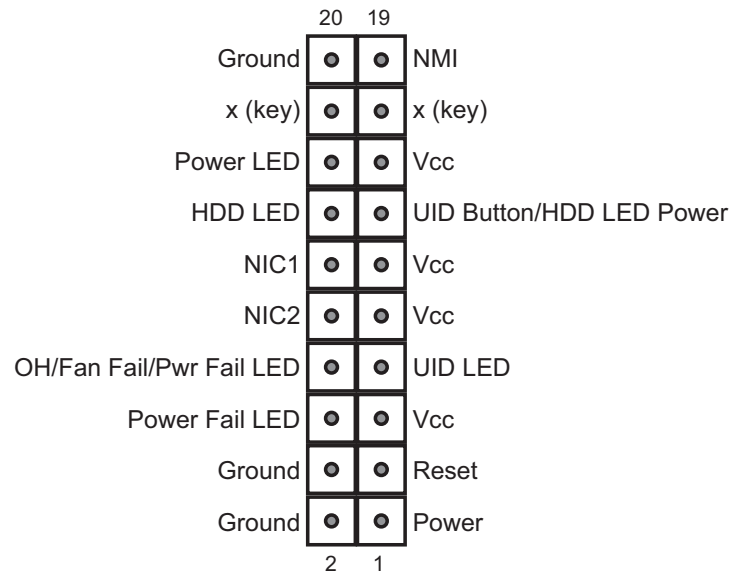

5-4 I/O Ports

The I/O ports are color coded in conformance with the PC 99 specification. See Figure 5-2 below for the colors and locations of the various I/O ports.

Figure 5-2. Rear Panel I/O Ports

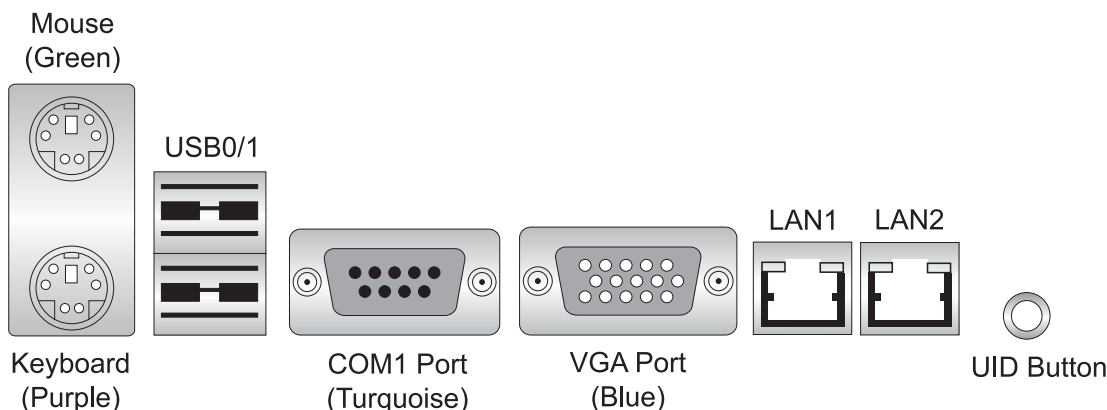

5-5 Installing Memory

CAUTION

Exercise extreme care when installing or removing memory modules to prevent any possible damage.

1. Insert each memory module vertically into its slot, paying attention to the notch along the bottom of the module to prevent inserting the module incorrectly (see Figure 2-2). See support information below.
2. Gently press down on the memory module until it snaps into place.

Note: each processor has its own built-in memory controller, so the CPU2 DIMMs cannot be addressed if only a single CPU is installed. 256 MB, 512 MB, 1 GB, 2 GB and 4 GB memory modules are supported. It is highly recommended that you remove the power cord from the system before installing or changing any memory modules.

Support

The H8DMU+ supports single or dual-channel, DDR2-667/533/400 registered ECC SDRAM. Both interleaved and non-interleaved memory are supported, so you may populate any number of DIMM slots (see note above and chart on following page). The CPU2 DIMM slots can only be accessed when two CPUs are installed

(however, the CPU2 DIMM slots are not required to be populated when two CPUs are installed).

Populating two adjacent slots at a time with memory modules of the same size and type will result in interleaved (128-bit) memory, which is faster than non-interleaved (64-bit) memory.

Optimizing memory performance

If two processors are installed, it is better to stagger pairs of DIMMs across both sets of CPU DIMM slots, e.g. first populate CPU1 slots 1A and 1B, then CPU2 slots 1A, and 1B, then the next two CPU1 slots, etc. This balances the load over both CPUs to optimize performance.

Maximum memory: 64 GB of DDR2-667/533/400 reg. ECC SDRAM - if only one CPU is installed, maximum supported memory is halved (32 GB).

Populating Memory Banks for 128-bit Operation							
CPU1 1A/1B	CPU1 2A/2B	CPU1 3A/3B	CPU1 4A/4B	CPU2 1A/1B	CPU2 2A/2B	CPU2 3A/3B	CPU2 4A/4B
X							
X				X			
X	X			X			
X	X			X	X		
X	X	X		X	X		
X	X	X		X	X	X	
X	X	X	X	X	X	X	
X	X	X	X	X	X	X	X

Notes: X indicates a pair of populated DIMM slots. If adding at least four DIMMs (with two CPUs installed), the configurations with DIMMs spread over both CPUs will result in optimized performance. Note that the first two DIMMs must be installed in the CPU1 memory slots.

Figure 5-3. Installing DIMM into Slot

To Install: Insert module vertically and press down until it snaps into place. Pay attention to the bottom notch.

To Remove: Use your thumbs to gently push each release tab outward to free the DIMM from the slot.

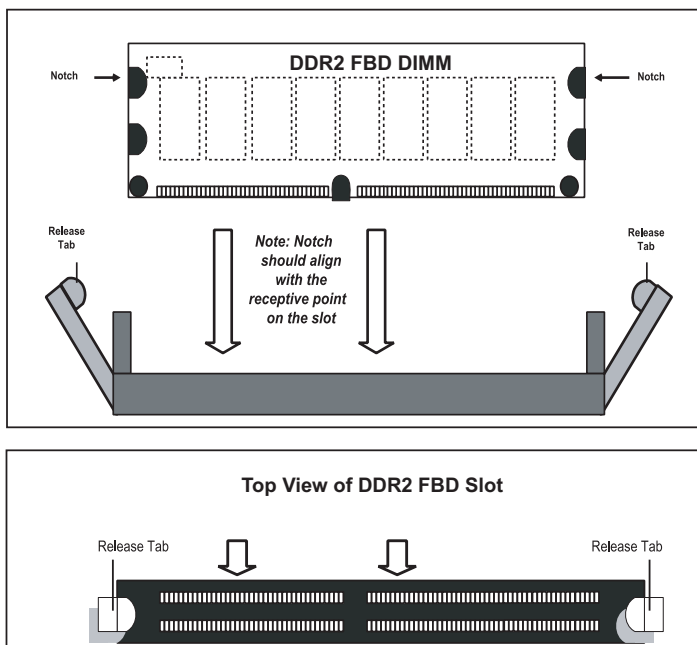

5-6 Adding PCI Cards

1. PCI Expansion Slots

One riser card is used to support add-on cards to the system. The SC815TQ-R650 chassis can accommodate one standard size (full height full length) PCI-E x8 card and one UIO card on the left side of the chassis (when viewed from the chassis front).

PCI cards are installed into riser card that has been pre-installed to the system. See configuration list below.

2. PCI card installation

Before installing a PCI add-on card, make sure you install it into the correct slot on the riser card. Begin by releasing the locking tab that corresponds to the slot you wish to populate. Insert the expansion card into the correct riser card, pushing down with your thumbs evenly on both sides of the card.

PCI Slot/Card Configuration

Riser Card
CSE-R1UU-UE8 (pre-installed)

Expansion cards supported
1x UIO card and 1x PCI-E x8 card

5-7 Serverboard Details

Figure 5-4. SUPER H8DMU+ Layout
(not drawn to scale)

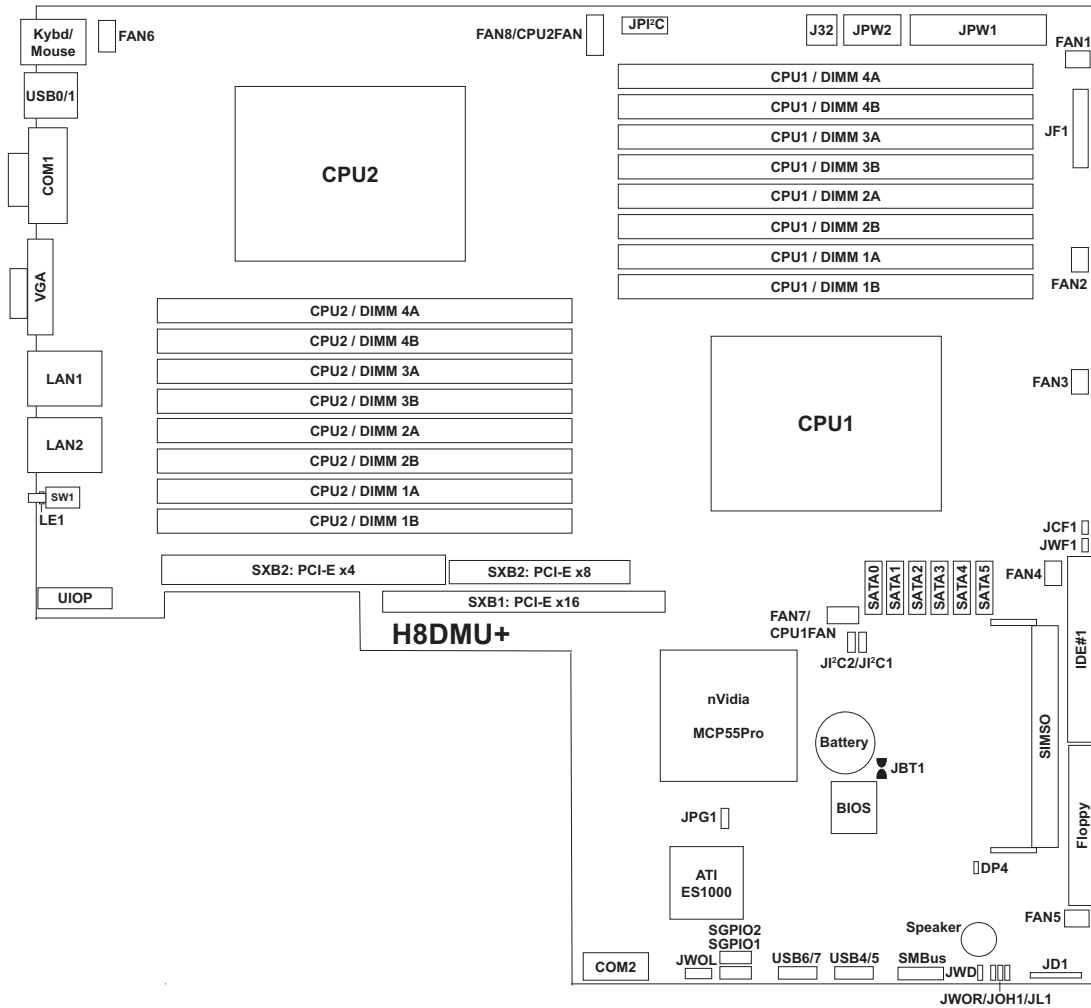

Notes:

1. Jumpers not indicated are for test purposes only.
2. There are no "USB2/3" ports or headers.

H8DMU+ Quick Reference

Jumper	Description	Default Setting
JBT1	CMOS Clear	See Section 5-9
JCF1	Compact Flash Card Master/Slave	Closed (Master)
JD1	Onboard Speaker	Pins 6-7 (Enabled)
JPG1	Onboard VGA Enable/Disable	Pins 1-2 (Enabled)
JI ² C1/JI ² C2	I ² C to PCI-Express Enable/Disable	Closed (Enabled)
JWD	Watch Dog	Pins 1-2 (Reset)

Connector	Description
COM1/COM2	COM1/COM2 Serial Port Connector/Header
FAN 1-8	Fan Headers 1-8
Floppy	Floppy Disk Drive Connector
IDE#1	IDE Hard Drive Connector
J32	Auxiliary Power Connector (4-pin)
JD1	Power LED (pins1-3)/Speaker Header (pins 4-7)
JF1	Front Control Panel Connector
JL1	Chassis Intrusion Header
JOH1	Overheat LED
JPI ² C	System Management (I ² C) Power Header
JPW1	Primary 20-Pin ATX Power Connector
JPW2	Processor Power Connector (8-pin)
JWF1	Compact Flash Card Power Connector
JWOL	Wake-on-LAN Header
JWOR	Wake-on-Ring Header
LAN1/2	Gigabit Ethernet Ports
SATA0~SATA5	SATA Ports
SGPIO1/SGPIO2	SGPIO Headers
SIMSO	IPMI 2.0 (with virtual media over LAN) Slot
SMBus	System Management Bus Header
UIOP	Power Connector for UIO Card
USB0/1	USB Ports
USB4/5	USB4/USB5 Headers
USB6/7	USB6/USB7 Headers

Other	Description
DP4	Onboard Power LED (3.3V)
LE1	Rear UID LED
SW1	UID (Unit Identifier) Button

5-8 Connector Definitions

ATX Power Connector

The primary ATX power supply connector (JPW1) meets the SSI (Super-set ATX) 20-pin specification. Refer to the table on the right for the pin definitions of the ATX power connector. This connection supplies power to the chipset, fans and memory.

Note: You must also connect the 8-pin (JPW2) and 4-pin (J32) power connectors to your power supply (see below).

ATX Power 20-pin Connector Pin Definitions (JPW1)			
Pin#	Definition	Pin #	Definition
11	+3.3V	1	+3.3V
12	-12V	2	+3.3V
13	COM	3	COM
14	PS_ON	4	+5V
15	COM	5	COM
16	COM	6	+5V
17	COM	7	COM
18	-5V	8	PWR_OK
19	+5V	9	5VSB
20	+5V	10	+12V

Processor Power Connector

In addition to the primary ATX power connector (above), the 12v, 8-pin processor power connector at JPW2 must also be connected to your power supply. This connection supplies power to the CPUs. See the table on the right for pin definitions.

Processor Power Connector Pin Definitions (JPW2)	
Pins	Definition
1 through 4	Ground
5 through 8	+12V

Required Connection

Auxiliary Power Connector

The 4-pin auxiliary power connector at J32 must also be connected to your power supply. This connection supplies extra power that may be needed for high loads. See the table on the right for pin definitions.

Auxiliary Power Connector Pin Definitions (J32)	
Pins	Definition
1 & 2	Ground
3 & 4	+12V

Required Connection

Power LED

The Power LED connection is located on pins 15 and 16 of JF1. Refer to the table on the right for pin definitions.

Power LED Pin Definitions (JF1)	
Pin#	Definition
15	Vcc
16	Control

HDD LED

The HDD (IDE Hard Disk Drive) LED connection is located on pins 13 and 14 of JF1. Attach the IDE hard drive LED cable to display disk activity. Refer to the table on the right for pin definitions.

HDD LED Pin Definitions (JF1)	
Pin#	Definition
13	See below*
14	HDD Active

* Pin 13 is for UID button (when used with UID panel) or for 3.3V power for HDD LED (when used with non-UID panel)

NIC1 LED

The NIC1 (Network Interface Controller) LED connection is located on pins 11 and 12 of JF1. Attach the NIC1 LED cable to display network activity. Refer to the table on the right for pin definitions.

NIC1 LED Pin Definitions (JF1)	
Pin#	Definition
11	Vcc
12	NIC1 Active

NIC2 LED

The NIC2 (Network Interface Controller) LED connection is located on pins 9 and 10 of JF1. Attach the NIC2 LED cable to display network activity. Refer to the table on the right for pin definitions.

NIC2 LED Pin Definitions (JF1)	
Pin#	Definition
9	Vcc
10	NIC2 Active

Overheat/Fan Fail/Power Fail/UID LED

Connect an LED to pins 7 and 8 of JF1 to provide advanced warning of chassis overheating, a fan failure or a power supply failure. These pins also work with the front UID indicator, which will activate as either a solid or flashing blue LED depending on whether the LED was activated via IPMI or the UID button. Refer to the tables on the right for pin definitions and status indicators.

OH/Fan Fail/Power Fail LED Pin Definitions (JF1)	
Pin#	Definition
7	UID LED Signal
8	OH/Fan Fail/Pwr Fail Signal

Red LED Indications	
State	Indication
Solid	Overheat
Blinking (1/4 Hz)	Power Fail
Blinking (1 Hz)	Fan Fail

Blue LED Indications	
State	Indication
Solid	UID (via Button)
Blinking	UID (via IPMI)

Power Fail LED

The Power Fail LED connection is located on pins 5 and 6 of JF1. Refer to the table on the right for pin definitions. This feature is only available for systems with redundant power supplies.

Power Fail LED Pin Definitions (JF1)	
Pin#	Definition
5	Vcc
6	Control

Reset Button

The Reset Button connection is located on pins 3 and 4 of JF1. Attach it to the hardware reset switch on the computer case. Refer to the table on the right for pin definitions.

Reset Button Pin Definitions (JF1)	
Pin#	Definition
3	Reset
4	Ground

Power Button

The Power Button connection is located on pins 1 and 2 of JF1. Momentarily contacting both pins will power on/off the system. This button can also be configured to function as a suspend button (see the Power Button Mode setting in BIOS). To turn off the power when set to suspend mode, depress the button for at least 4 seconds. Refer to the table on the right for pin definitions.

Power Button Pin Definitions (JF1)	
Pin#	Definition
1	PW_ON
2	Ground

Universal Serial Bus Ports (USB0/1)

Two Universal Serial Bus ports (USB2.0) are located beside the mouse/keyboard ports. See the table on the right for pin definitions.

Universal Serial Bus Ports Pin Definitions (USB0/1)			
USB0		USB1	
Pin #	Definition	Pin #	Definition
1	+5V	1	+5V
2	PO-	2	PO-
3	PO+	3	PO+
4	Ground	4	Ground

USB Headers

Four additional USB2.0 headers (USB4/5 and USB6/7) are included on the serverboard. These may be connected to provide front side access. A USB cable (not included) is needed for the connection. See the table on the right for pin definitions.

Universal Serial Bus Headers Pin Definitions (USB4/5/6/7)			
USB2		USB3/4	
Pin #	Definition	Pin #	Definition
1	+5V	1	+5V
2	PO-	2	PO-
3	PO+	3	PO+
4	Ground	4	Ground
5	Key	5	No connection

Serial Ports

The COM1 serial port is located beside the VGA port. COM2 is a header located near JWOL. Refer to the table on the right for pin definitions.

Serial Port Pin Definitions (COM1/COM2)			
Pin #	Definition	Pin #	Definition
1	DCD	6	DSR
2	RXD	7	RTS
3	TXD	8	CTS
4	DTR	9	RI
5	Ground	10	NC

Note: NC indicates no connection.

Fan Headers

The H8DMU+ has eight fan headers, which are designated FAN1 through FAN8. FAN7 and FAN8 (for active CPU heatsinks) are Pulse Width Modulated (PWM): their speed is controlled via a BIOS setting. See the table on the right for pin definitions.

Note: when using active heatsinks (those with fans), connect the heatsink fan for CPU1 to the FAN7 header and the heatsink fan for CPU2 to the FAN8 header.

Fan Header Pin Definitions (FAN1-8)	
Pin#	Definition
1	Ground (Black)
2	+12V (Red)
3	Tachometer
4	PWM Control

LAN1/2 (Ethernet Ports)

Two Gigabit Ethernet ports (designated LAN1 and LAN2) are located beside the VGA port. These Ethernet ports accept RJ45 type cables.



Power LED/Speaker

On JD1, pins 1, 2, and 3 are for the power LED and pins 4 through 7 are for the speaker. See the tables on the right for pin definitions.

Note: The speaker connector pins are for use with an external speaker. If you wish to use the onboard speaker, you should close pins 6 and 7 with a jumper.

PWR LED Connector Pin Definitions (JD1)	
Pin#	Definition
1	+Vcc
2	Control
3	Control

Speaker Connector Pin Definitions (JD1)	
Pin#	Definition
4	Red wire, +5V
5	No connection
6	Buzzer signal
7	Speaker data

ATX PS/2 Keyboard and PS/2 Mouse Ports

The ATX PS/2 keyboard and the PS/2 mouse ports are located on the I/O backplane. The mouse is the top (green) port. See the table on the right for pin definitions.

PS/2 Keyboard and Mouse Port Pin Definitions	
Pin#	Definition
1	Data
2	NC
3	Ground
4	VCC
5	Clock
6	NC

Overheat LED

Connect an LED to the JOH1 header to provide warning of chassis overheating. See the table on the right for pin definitions.

Overheat LED Pin Definitions (JOH1)	
Pin#	Definition
1	3.3V
2	OH Active

Chassis Intrusion

A Chassis Intrusion header is located at JL1. Attach the appropriate cable to inform you of a chassis intrusion.

Chassis Intrusion Pin Definitions (JL1)	
Pin#	Definition
1	Battery voltage
2	Intrusion signal

Wake-On-LAN

The Wake-On-LAN header is designated JWOL. See the table on the right for pin definitions. You must have a LAN card with a Wake-On-LAN connector and cable to use the Wake-On-LAN feature.

(Note: Wake-On-LAN from S3, S4, S5 are supported by LAN1. LAN2 supports Wake-On-LAN from S1 only.)

Wake-On-LAN Pin Definitions (JWOL)	
Pin#	Definition
1	+5V Standby
2	Ground
3	Wake-up

Wake-On-Ring

The Wake-On-Ring header is designated JWOR. This function allows your computer to receive and "wake-up" by an incoming call to the modem when in suspend state. See the table on the right for pin definitions. You must have a Wake-On-Ring card and cable to use this feature.

Wake-On-Ring Pin Definitions (JWOR)	
Pin#	Definition
1	Ground (Black)
2	Wake-up

Power Supply I²C Header

The JPI²C header is for I²C, which may be used to monitor the status of the power supply, fans and system temperature. See the table on the right for pin definitions.

I ² C Header Pin Definitions (JPI ² C)	
Pin#	Definition
1	Clock
2	Data
3	PWR Fail
4	Gnd
5	+3.3V

SMBus Header

The SMBus header is for the System Management Bus. Connect the appropriate cable here to utilize SMB on the system. See the table on the right for pin definitions.

SMBus Header Pin Definitions (SMBus)	
Pin#	Definition
1	Data
2	Ground
3	Clock
4	No Connection

Power Fail Alarm Reset Header

Connect JAR to the alarm reset button on your chassis (if available) or to a microswitch to allow you to turn off the alarm that sounds when a power supply module fails. See the table on the right for pin definitions.

Alarm Reset Header Pin Definitions (JAR)	
Pin#	Definition
1	Ground
2	Reset Signal

Compact Flash Power

A Compact Flash Card Power Connector is located at JWF1. For the Compact Flash Card to work properly, you will first need to connect the device's power cable to JWF1 and correctly set the Compact Flash Jumper (JCF1).

Compact Flash Power Header Pin Definitions (JWF1)	
Pin#	Definition
1	+5V
2	Ground
3	Signal

SGPIO

SGPIO1 and SGPIO2 (Serial General Purpose Input/Output) provide a bus between the SATA controller and the SATA drive backplane to provide SATA enclosure management functions. Connect the appropriate cables from the backplane to the SGPIO1 and SGPIO2 header(s) to utilize SATA management functions on your system.

SGPIO Header Pin Definitions (SGPIO1, SGPIO2)			
Pin#	Definition	Pin #	Definition
1	NC	2	NC
3	Ground	4	Data
5	Load	6	Ground
7	NC	8	NC

Note: NC indicates no connection.

UID Button (SW1)

The SW1 button beside LAN2 provides a UID (Unit Identifier) function. Push the button to illuminate an LED on the front of the chassis to help locate the server in a heavily populated rack.

5-9 Jumper Settings

Explanation of Jumpers

To modify the operation of the serverboard, jumpers can be used to choose between optional settings. Jumpers create shorts between two pins to change the function of the connector. Pin 1 is identified with a square solder pad on the printed circuit board. See the diagram at right for an example of jumping pins 1 and 2. Refer to the serverboard layout page for jumper locations.

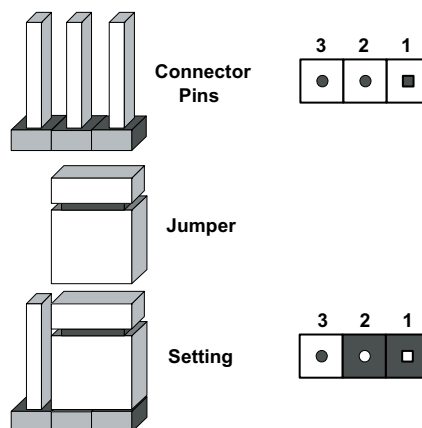

Note: On two-pin jumpers, "Closed" means the jumper is on and "Open" means the jumper is off the pins.

CMOS Clear

JBT1 is used to clear CMOS and will also clear any passwords. Instead of pins, this jumper consists of contact pads to prevent accidentally clearing the contents of CMOS.

To clear CMOS,

- 1) First power down the system and unplug the power cord(s).
- 2) With the power disconnected, short the CMOS pads with a metal object such as a small screwdriver for at least four seconds.
- 3) Remove the screwdriver (or shorting device).
- 4) Reconnect the power cord(s) and power on the system.

Notes:

Do not use the PW_ON connector to clear CMOS.

The onboard battery does not need to be removed when clearing CMOS, however you must short JBT1 for at least four seconds.



JBT1 contact pads

VGA Enable/Disable

JPG1 allows you to enable or disable the VGA port. The default position is on pins 1 and 2 to enable VGA. See the table on the right for jumper settings.

VGA Enable/Disable Jumper Settings (JPG1)	
Jumper Setting	Definition
Pins 1-2	Enabled
Pins 2-3	Disabled

Watch Dog

JWD controls Watch Dog, a system monitor that takes action when a software application freezes the system. Jumping pins 1-2 will cause WD to reset the system if an application is hung up. Jumping pins 2-3 will generate a non-maskable interrupt signal for the application that is hung up. See the table on the right for jumper settings. Watch Dog can also be enabled via BIOS.

Watch Dog Jumper Settings (JWD)	
Jumper Setting	Definition
Pins 1-2	Reset
Pins 2-3	NMI
Open	Disabled

Note: When enabled, the user needs to write their own application software in order to disable the Watch Dog timer.

Onboard Speaker Enable/Disable

The JD1 header allows you to use either an external speaker or the internal (onboard) speaker. To use the internal onboard speaker, close pins 6 and 7 with a jumper. To use an external speaker, remove the jumper and connect the speaker wires to pins 4 (+5V) and 7 (control signal). See the table on the right for settings and the table associated with the Power LED/Keylock/Speaker connection (previous section) for jumper settings.

Onboard Speaker Enable/Disable Pin Definitions (JD1)	
Pins	Definition
6 and 7	Jump for onboard speaker
4 and 7	Attach external speaker wires

Note: Pins 4-7 are used only for the onboard speaker.

Compact Flash Master/Slave

The JCF1 jumper allows you to assign either master or slave status a compact flash card installed in IDE1. See the table on the right for jumper settings.

Compact Flash Master/Slave Jumper Settings (JCF1)	
Jumper Setting	Definition
Closed	Master
Open	Slave

I²C to PCI-Express Enable/Disable

The JI²C1/JI²C2 pair of jumpers allows you to connect the System Management Bus to any one of the PCI-Express slots. The default setting is closed for both jumpers to enable the connection. Both connectors must have the same setting (JI²C1 is for data and JI²C2 is for the clock). See the table on right for jumper settings.

I ² C to PCI Enable/Disable Jumper Settings (JI ² C1/JI ² C2)	
Jumper Setting	Definition
Closed	Enabled
Open	Disabled

5-10 Onboard Indicators

LAN1/LAN2 LEDs

The Ethernet ports (located beside the VGA port) have two LEDs. On each Gb LAN port, one LED indicates activity when blinking while the other LED may be amber or off to indicate the speed of the connection. See the table on the right for the functions associated with the connection speed LED.

LAN LED (Connection Speed Indicator)	
LED Color	Definition
Off	10/100 MHz
Amber	1 GHz

+3.3V LED (DP4)

When illuminated, the DP4 LED indicates that power (+3.3V) is present on the serverboard. DP4 should normally be illuminated when the system turned on.

UID LED (LE1)

The LE1 LED will illuminate when the UID button is pressed. Pressing the button a second time will turn this LED off. The UID LED is used to help locate specific servers in heavily populated server racks.

5-11 Floppy, IDE and SATA Drive Connections

Use the following information to connect the floppy and hard disk drive cables.

- The floppy disk drive cable has seven twisted wires.
- A red mark on a wire typically designates the location of pin 1.
- A single floppy disk drive ribbon cable has 34 wires and two connectors to provide for two floppy disk drives. The connector with twisted wires always connects to drive A, and the connector that does not have twisted wires always connects to drive B.
- The 80-wire ATA133 IDE hard disk drive cable that came with your system has two connectors to support two drives. This special cable should be used to take advantage of the speed this new technology offers. The blue connector connects to the onboard IDE connector interface and the other connector(s) to your hard drive(s). Consult the documentation that came with your disk drive for details on actual jumper locations and settings for the hard disk drive.

Floppy Connector

The floppy connector is located beside the IDE connector. See the table on the right for pin definitions.

Floppy Drive Connector Pin Definitions (Floppy)			
Pin#	Definition	Pin #	Definition
1	GND	2	FDHDIN
3	GND	4	Reserved
5	Key	6	FDEDIN
7	GND	8	Index-
9	GND	10	Motor Enable
11	GND	12	Drive Select B-
13	GND	14	Drive Select A-
15	GND	16	Motor Enable
17	GND	18	DIR-
19	GND	20	STEP-
21	GND	22	Write Data-
23	GND	24	Write Gate-
25	GND	26	Track 00-
27	GND	28	Write Protect-
29	GND	30	Read Data-
31	GND	32	Side 1 Select-
33	GND	34	Diskette

IDE Connector

There are no jumpers to configure the onboard IDE#1 connectors. See the table on the right for pin definitions.

IDE Drive Connectors Pin Definitions (IDE#1)			
Pin#	Definition	Pin #	Definition
1	Reset IDE	2	Ground
3	Host Data 7	4	Host Data 8
5	Host Data 6	6	Host Data 9
7	Host Data 5	8	Host Data 10
9	Host Data 4	10	Host Data 11
11	Host Data 3	12	Host Data 12
13	Host Data 2	14	Host Data 13
15	Host Data 1	16	Host Data 14
17	Host Data 0	18	Host Data 15
19	Ground	20	Key
21	DRQ3	22	Ground
23	I/O Write	24	Ground
25	I/O Read	26	Ground
27	IOCHRDY	28	BALE
29	DACK3	30	Ground
31	IRQ14	32	IOCS16
33	Addr1	34	Ground
35	Addr0	36	Addr2
37	Chip Select 0	38	Chip Select 1
39	Activity	40	Ground

SATA Ports

There are no jumpers to configure the SATA ports, which are designated SATA0 through SATA5. See the table on the right for pin definitions.

SATA Ports Pin Definitions (SATA0-SATA5)	
Pin #	Definition
1	Ground
2	TXP
3	TXN
4	Ground
5	RXN
6	RXP
7	Ground

5-12 Enabling SATA RAID

Serial ATA (SATA)

Serial ATA (SATA) is a physical storage interface that employs a single cable with a minimum of four wires to create a point-to-point connection between devices. This connection is a serial link. The serial cables used in SATA are thinner than the traditional cables used in Parallel ATA (PATA) and can extend up to one meter in length, compared to only 40 cm for PATA cables. Overall, SATA provides better functionality than PATA.

Installing the OS/SATA Driver

Before installing the OS (operating system) and SATA RAID driver, you must decide if you wish to have the operating system installed as part of a bootable RAID array or installed to a separate non-RAID hard drive. If on a separate drive, you may install the driver either during or after the OS installation. If you wish to have the OS on a SATA RAID array, you must follow the procedure below and install the driver during the OS installation.

Building a Driver Diskette

You must first build a driver diskette from the CD-ROM that was included with the system. (You will have to create this disk on a computer that is already running and with the OS installed.) Insert the CD into your CD-ROM drive and start the system. A display as shown in Figure 5-7 will appear. Click on the icon labeled "Build Driver Diskettes and Manuals" and follow the instructions to create a floppy disk with the driver on it. Once it's been created, remove the floppy and insert the installation CD for the Windows Operating System you wish to install into the CD-ROM drive of the new system you are about to configure.

Enabling SATA RAID in the BIOS

Before installing the Windows Operating System, you must change some settings in BIOS. Boot up the system and hit the key to enter the BIOS Setup Utility. After the Setup Utility loads,

1. Use the arrow keys to move to the Exit menu. Scroll down with the arrow keys to the "Load Optimal Defaults" setting and press <Enter>. Select "OK" to confirm, then <Enter> to load the default settings.

2. Use the arrow keys to move to Advanced > Floppy/IDE/SATA Configuration > nVidia RAID Setup and press the <Enter> key. Once in the submenu, enable the "nVidia RAID Function" setting.
3. Hit the <F10> key to "Save Changes and Exit", then hit <Enter> to verify.
4. After exiting the BIOS Setup Utility, the system will reboot. When prompted during the startup, press the <F10> key when prompted to run the nVidia RAID Utility program.

Using the nVidia RAID Utility

The nVidia RAID Utility program is where you can define the drives you want to include in the RAID array and the mode and type of RAID. Two main windows are shown in the utility (see Figure 5-5). The "Free Disks" window on the left will list all available drives. Use the arrow keys to select and move drives to the window on the right, which lists all drives that are to become part of the RAID array.

Once you have finished selecting the drives and type of RAID you wish to use for your RAID array, press the <F7> key. You will be prompted to verify your choice; if you want to continue with your choices, select "Yes". Note that selecting "Yes" will clear all previous data from the drives you selected to be a part of the array. You are then given the choice of making the RAID array bootable by pressing the the key. After you have finished, press the <Ctrl> and <X> keys simultaneously. Figure 5-6 shows a list of arrays that have been set up with the utility.

Installing the OS and Drivers

With the Windows OS installation CD in the CD-ROM drive, restart the system. When you see the prompt, hit the <F6> key to enter Windows setup. Eventually a blue screen will appear with a message that begins "Windows could not determine the type of one or more storage devices . . ." When you see the screen, hit the <S> key to "Specify Additional Device", then insert the driver diskette you just created into the floppy drive. Highlight "Manufacturer Supplied Hardware Support Disk" and hit the <Enter> key. Highlight the first "nVidia RAID" driver shown and press the <Enter> key to install it. Soon a similar blue screen will appear again. Again hit the <S> key, then highlight the second item, "nForce Storage Controller" and press the <Enter> key, then <Enter> again to continue with the Windows setup.

Figure 5-5. SATA RAID Utility: Main Screen

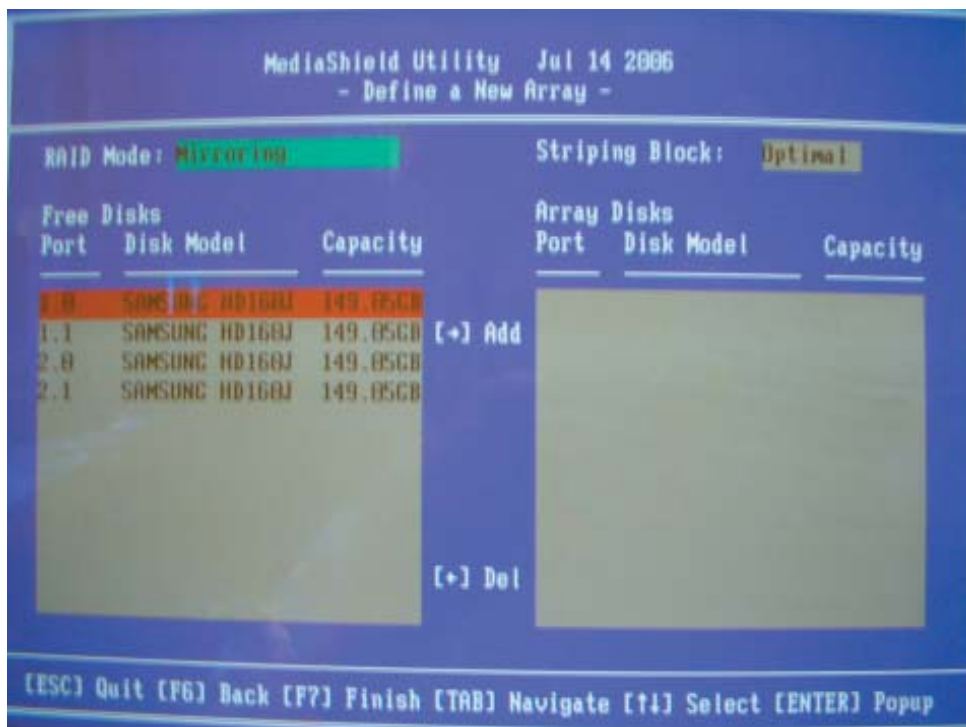

Figure 5-6. SATA RAID Utility: Array List



5-13 Installing Drivers

After all the hardware and operating system have been installed, you need to install certain drivers. The necessary drivers are all included on the Supermicro CD that came packaged with your serverboard. After inserting this CD into your CD-ROM drive, the display shown in Figure 5-7 should appear. (If this display does not appear, click on the My Computer icon and then on the icon representing your CD-ROM drive. Finally, double click on the S "Setup" icon.)

Figure 5-7. Driver Installation Display Screen



Click the icons showing a hand writing on paper to view the readme files for each item. Click the tabs to the right of these *in order from top to bottom* to install each item one at a time. **After installing each item, you must reboot the system before moving on to the next item on the list.** You should install everything here except for the SUPER Doctor utility, which is optional. The bottom icon with a CD on it allows you to view the entire contents of the CD.

Chapter 6

Advanced Chassis Setup

This chapter covers the steps required to install components and perform maintenance on the SC815TQ-R650U chassis. For component installation, follow the steps in the order given to eliminate the most common problems encountered. If some steps are unnecessary, skip ahead to the next step.

Tools Required

The only tool you will need to install components and perform maintenance is a Philips screwdriver.

6-1 Static-Sensitive Devices

Electrostatic discharge (ESD) can damage electronic components. To prevent damage to any printed circuit boards (PCBs), it is important to handle them very carefully. The following measures are generally sufficient to protect your equipment from ESD damage.

Precautions

- Use a grounded wrist strap designed to prevent static discharge.
- Touch a grounded metal object before removing any board from its antistatic bag.
- Handle a board by its edges only; do not touch its components, peripheral chips, memory modules or gold contacts.
- When handling chips or modules, avoid touching their pins.
- Put the serverboard, add-on cards and peripherals back into their antistatic bags when not in use.
- For grounding purposes, make sure your computer chassis provides excellent conductivity between the power supply, the case, the mounting fasteners and the serverboard.

Figure 6-1. Chassis: Front and Rear Views

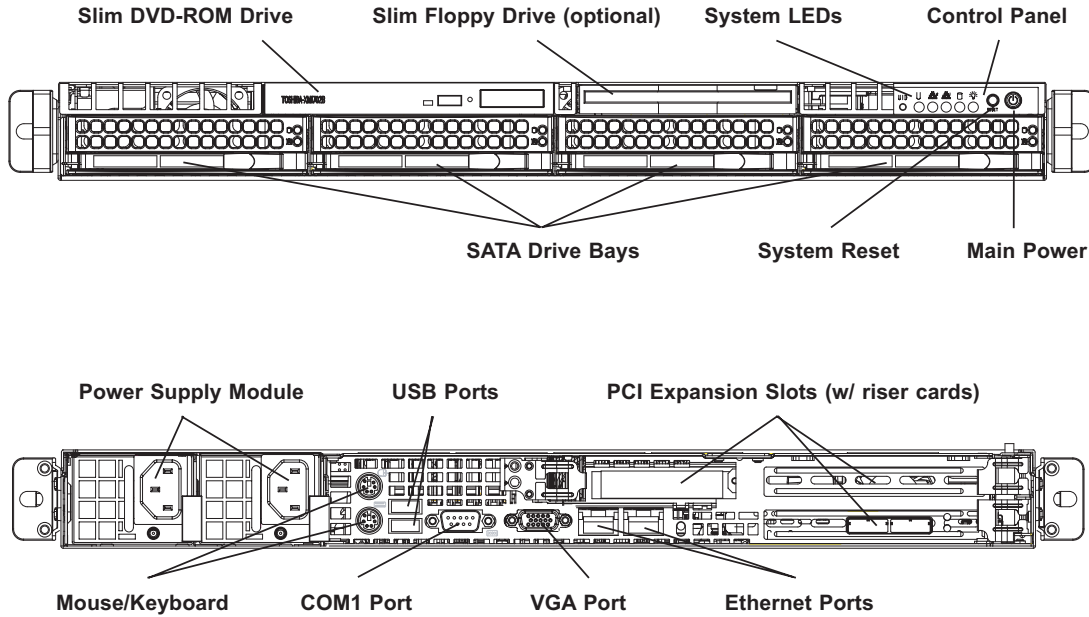

6-2 Control Panel

The control panel (located on the front of the chassis) must be connected to the JF1 connector on the serverboard to provide you with system status indications. These wires have been bundled together as a ribbon cable to simplify the connection. Connect the cable from JF1 on the serverboard to the appropriate header on the Control Panel PCB (printed circuit board). Make sure the red wire plugs into pin 1 on both connectors. Pull all excess cabling out of the airflow path.

The control panel LEDs inform you of system status. See "Chapter 3: System Interface" for details on the LEDs and the control panel buttons. Details on JF1 can be found in "Chapter 5: Advanced Serverboard Setup."

6-3 System Fans

Four 4-cm heavy duty counter-rotating fans provide the cooling for the 1021M-UR+. Each fan unit is actually made up of two fans joined back-to-back, which rotate in opposite directions. This counter-rotating action generates exceptional airflow and works to dampen vibration levels. It is very important that the chassis top cover is properly installed and making a good seal in order for the cooling air to circulate properly through the chassis and cool the components. See Figure 6-2. (An optional 5th fan can be added to the far left fan position.)

System Fan Failure

Fan speed is controlled by system temperature via a BIOS setting. If a fan fails, the remaining fan will ramp up to full speed and the Universal Information LED on the control panel will blink red quickly. Replace any failed fan at your earliest convenience with the same type and model (the system can continue to run with a failed fan). Remove the top chassis cover while the system is still running to determine which of the two fans has failed. Then power down the system before replacing a fan. Removing the power cords is also recommended as a safety precaution.

Replacing System Fans

1. Removing a fan

After turning off the power to the system, first remove the chassis cover and unplug the fan cable from the motherboard. Unscrew the failed blower fan from the chassis and pull it completely out from the serverboard.

2. Installing a new fan

Replace the failed fan with an identical 4-cm, 12 volt fan (available from Supermicro: p/n FAN-0086L). Push the new fan into the vacant space in the housing while making sure the arrows on the top of the fan (indicating air direction) point in the same direction as the arrows on the other fans. Reposition the fan housing back over the two mounting posts in the chassis, then reconnect the fan wires to the same chassis fan headers you removed them from. Power up the system and check that the fan is working properly and that the LED on the control panel has turned off. Finish by replacing the chassis cover.

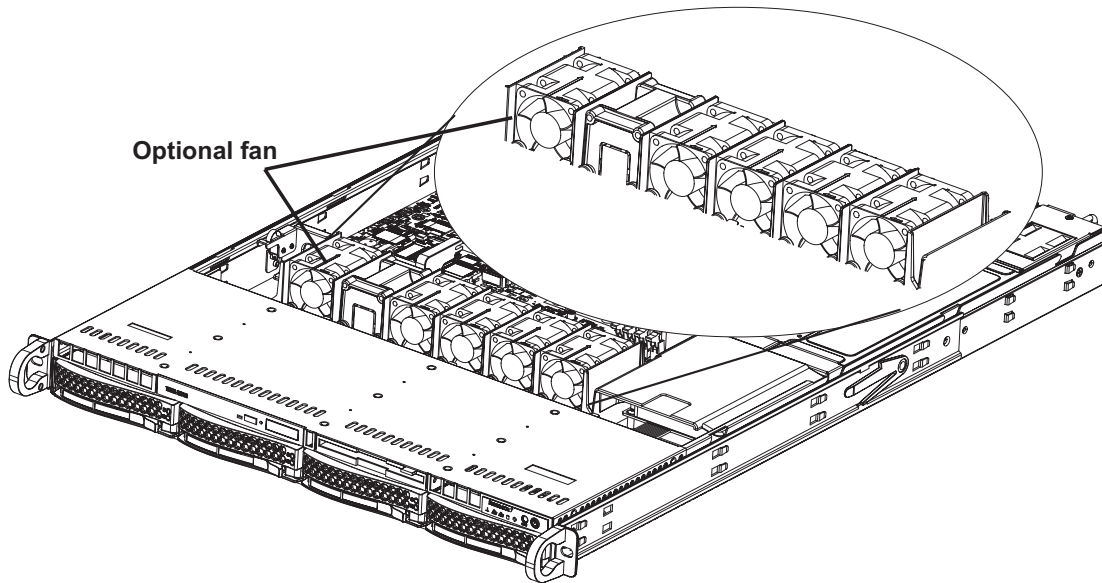
Figure 6-2. System Cooling Fans

6-4 Drive Bay Installation/Removal

Removing the Front Bezel

If your system has a front bezel (optional) attached to the chassis, you must first remove it to gain access to the drive bays. To remove the bezel, first unlock the front of the chassis then press the release knob (see Figure 6-3). Carefully remove the bezel with both hands. A filter located within the bezel can be removed for replacement/cleaning. It is recommended that you keep a maintenance log of filter cleaning/replacement, since its condition will affect the airflow throughout the whole system.

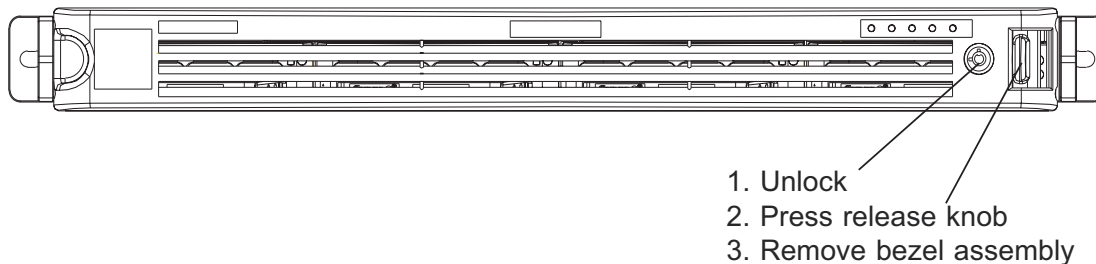
Figure 6-3. Removing the Front Bezel

Accessing the Drive Bays

SAS/SATA Drives: Because of their hotswap capability, you do not need to access the inside of the chassis or power down the system to install or replace SAS/SATA drives. Proceed to the next section for instructions.

DVD-ROM/Floppy Disk Drives: For installing/removing a DVD-ROM or floppy disk drive, you will need to gain access to the inside of the 1021M-UR+ by removing the top cover of the chassis. Proceed to the "DVD-ROM and Floppy Drive Installation" section later in this chapter for instructions.

Note: Only "slim" DVD-ROM and floppy drives will fit into the 1021M-UR+.

SAS/SATA Drive Installation

1. Mounting a SAS/SATA drive in a drive carrier

The SAS/SATA drives are mounted in drive carriers to simplify their installation and removal from the chassis. These carriers also help promote proper airflow for the drive bays. For this reason, even empty carriers without drives installed must remain in the chassis. To add a new drive, install a drive into the carrier with the printed circuit board side facing down so that the mounting holes align with those in the carrier. Secure the drive to the carrier with six screws, as shown in Figure 6-4.

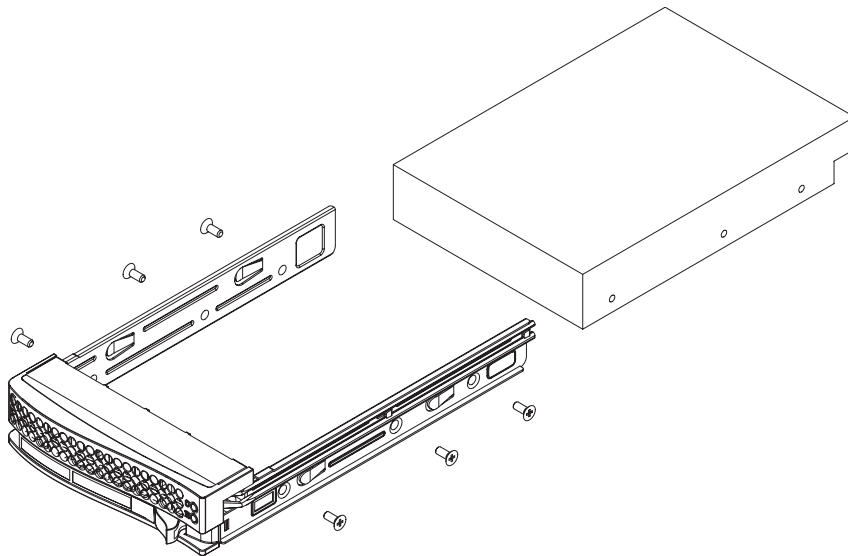

Figure 6-4. Mounting a SAS/SATA Drive in a Carrier



Use caution when working around the SAS/SATA backplane. Do not touch the backplane with any metal objects and make sure no ribbon cables touch the backplane or obstruct the holes, which aid in proper airflow.



Important: Regardless of how many SAS/SATA drives are installed, all drive carriers must remain in the drive bays to maintain proper airflow.

2. Installing/removing hot-swap SAS/SATA drives

The SAS/SATA drive carriers are all easily accessible at the front of the chassis. These hard drives are hot-pluggable, meaning they can be removed and installed without powering down the system. To remove a carrier, push the release button located beside the drive LEDs. Then swing the colored handle fully out and use it to pull the unit straight out (see Figure 6-5).

Note: Your operating system must have RAID support to enable the hot-plug capability of the SAS/SATA drives.

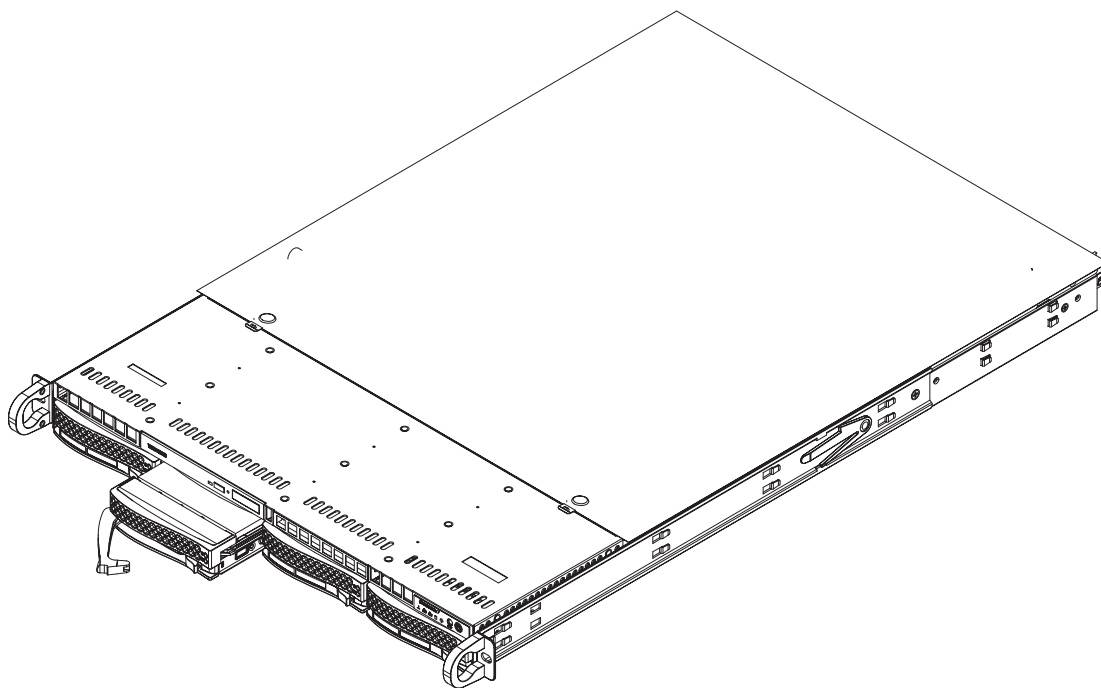

Figure 6-5. Removing a SAS/SATA Drive from the Server

DVD-ROM and Floppy Drive Installation

The top cover of the chassis must be opened to gain full access to the DVD-ROM and floppy drive bays. The 1021M-UR+ accommodates only slim-line DVD-ROM drives. Side mounting brackets are needed to mount a slim-line DVD-ROM drive in the 1021M-UR+ server.

You must power down the system before installing or removing a floppy or DVD-ROM drive. First, release the retention screws that secure the server unit to the rack. Grasp the two handles on either side and pull the unit straight out until it locks (you will hear a "click"). Next, depress the two buttons on the top of the chassis to release the top cover and at the same time, push the cover away from you until it stops. You can then lift the top cover from the chassis to gain full access to the inside of the server.

With the chassis cover removed, unplug the power and data cables from the drive you want to remove. Then locate the locking tab at the rear of the drive. It will be on the left side of the drive when viewed from the front of the chassis. Pull the tab away from the drive and push the drive unit out the front of the chassis. Add a new drive by following this procedure in reverse order. You may hear a faint *click* of the locking tab when the drive is fully inserted. Remember to reconnect the data and power cables to the drive before replacing the chassis cover and restoring power to the system. Please be aware of the following:

- The floppy disk drive cable has seven twisted wires.
- A color mark on a cable typically designates the location of pin 1.
- A single floppy disk drive ribbon cable has 34 wires and two connectors to provide for two floppy disk drives. The connector with twisted wires always connects to drive A, and the connector that does not have twisted wires always connects to drive B.

6-5 Power Supply

The 1021M-UR+ has a 650 watt redundant power supply configuration consisting of two hot-swap power modules. The power supply modules have an auto-switching capability, which enables them to automatically sense and operate with a 100V - 240V input voltage.

Power Supply Failure

If either of the two power supply modules fail, the other module will take the full load and allow the system to continue operation without interruption. The Universal Information LED on the control panel will turn red and blink slowly. Replacement modules can be ordered directly from Supermicro. The power supply modules have a hot-swap capability, meaning you can replace the failed module without powering down the system.

Removing/Replacing the Power Supply

You do not need to shut down the system to replace a power supply module. The redundant feature will keep the system up and running while you replace the failed hot-swap module. Replace with the same model, which can be ordered directly from Supermicro (see Contact Information in the Preface).

1. Removing the power supply

First unplug the power cord from the failed power supply module. To remove the failed power module, push the release tab (on the back of the power supply) to the side and then pull the module straight out (see Figure 6-6). The power supply wiring was designed to detach automatically when the module is pulled from the chassis.

2. Installing a new power supply

Replace the failed power module with another PWS-651-1R power supply module. Simply push the new power supply module into the power bay until you hear a click. Finish by plugging the AC power cord back into the module.

Figure 6-6. Removing/Replacing the Power Supply

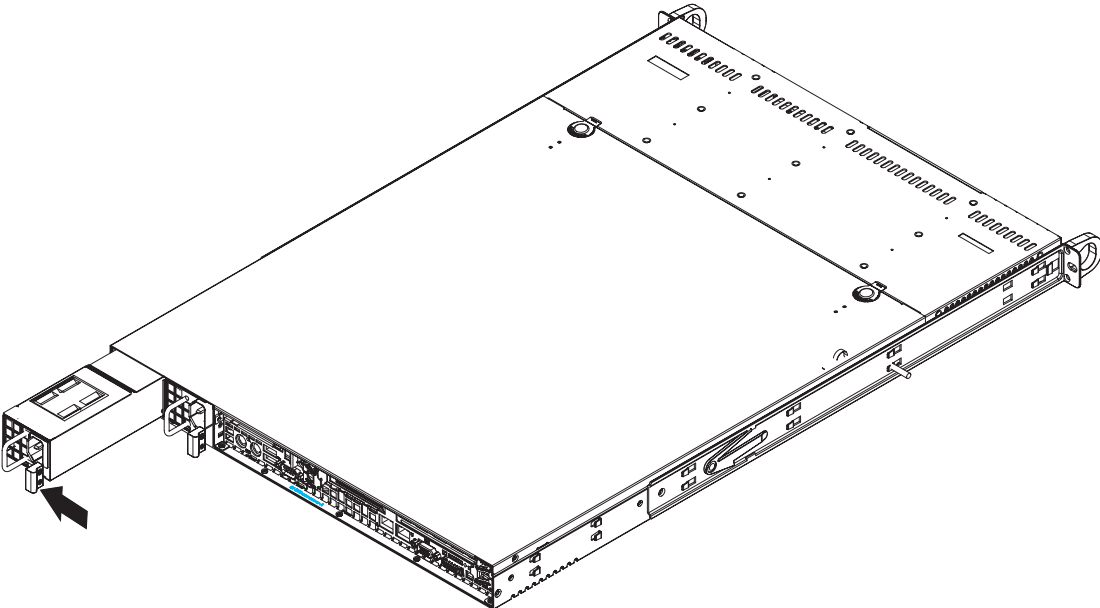

Chapter 7

BIOS

7-1 Introduction

This chapter describes the AMIBIOS™ Setup utility for the H8DMU+. The AMI ROM BIOS is stored in a flash chip and can be easily upgraded using a floppy disk-based program.

Note: Due to periodic changes to the BIOS, some settings may have been added or deleted and might not yet be recorded in this manual. Please refer to the Manual Download area of our web site for any changes to BIOS that may not be reflected in this manual.

Starting the Setup Utility

To enter the BIOS Setup Utility, hit the <Delete> key while the system is booting-up. (In most cases, the <Delete> key is used to invoke the BIOS setup screen. There are a few cases when other keys are used, such as <F1>, <F2>, etc.) Each main BIOS menu option is described in this manual.

The Main BIOS screen has two main frames. The left frame displays all the options that can be configured. “Grayed-out” options cannot be configured. The right frame displays the key legend. Above the key legend is an area reserved for a text message. When an option is selected in the left frame, it is highlighted in white. Often a text message will accompany it. (Note that BIOS has default text messages built in. We retain the option to include, omit, or change any of these text messages.) Settings printed in **Bold** are the default values.

A " ►" indicates a submenu. Highlighting such an item and pressing the <Enter> key will open the list of settings within that submenu.

The BIOS setup utility uses a key-based navigation system called hot keys. Most of these hot keys (<F1>, <F10>, <Enter>, <ESC>, <Arrow> keys, etc.) can be used at any time during the setup navigation process.

7-2 Main Menu

When you first enter AMI BIOS Setup Utility, you will see the Main Menu screen. You can always return to the Main Menu by selecting the **Main** tab on the top of the screen with the arrow keys.

The Main Menu screen provides you with a system overview, which includes the version, built date and ID of the AMIBIOS, the type, speed and number of the processors in the system and the amount of memory installed in the system.

System Time/System Date

You can edit this field to change the system time and date. Highlight *System Time* or *System Date* using the <Arrow> keys. Enter new values through the keyboard. Press the <Tab> key or the <Arrow> keys to move between fields. The date must be entered in DAY/MM/DD/YYYY format. The time is entered in HH:MM:SS format. Please note that time is in a 24-hour format. For example, 5:30 A.M. appears as 05:30:00 and 5:30 P.M. as 17:30:00.

7-3 Advanced Settings Menu

► BIOS Features

Quick Boot

If Enabled, this option will skip certain tests during POST to reduce the time needed for the system to boot up. The options are **Enabled** and Disabled.

Quiet Boot

If Disabled, normal POST messages will be displayed on boot-up. If **Enabled**, this display the OEM logo instead of POST messages.

OS Installation

Change this setting if using a Linux operating system. The available options are **Other** and Linux.

Interrupt 19 Capture

Select Enabled to allow ROMs to trap Interrupt 19. The options are Enabled and **Disabled**.

ACPI Mode

Use this setting to determine whether ACPI mode will be used. The options are **Yes** and No.

► **Advanced ACPI Configuration**

MCP55 ACPI HPET Table

Use this setting to Enable or **Disable** the MCP55 ACPI HPET Table.

ACPI Version Features

Use this setting to determine which ACPI version to use. Options are **ACPI v1.0**, ACPI v2.0 and ACPI v3.0.

ACPI APIC Support

Determines whether to include the ACPI APIC table pointer in the RSDT pointer list. The available options are **Enabled** and Disabled.

ACPI OEMB Table

Determines whether to include the ACPI APIC table pointer in the RSDT pointer list. The available options are **Enabled** and Disabled.

Headless Mode

Use this setting to Enable or **Disable** headless operation mode through ACPI.

ACPI HPET Table

Use this setting to **Enable** or Disable the ACPI HPET Table.

Power Button Mode

Allows the user to change the function of the power button. Options are **On/Off** and Suspend.

Watch Dog Timer Select

This setting is used to Enable or **Disable** the Watch Dog Timer function. It must be used in conjunction with the Watch Dog jumper (see Chapter 2 for details). To enable, choose from 1, 2, 3, 4, 8, 15 or 30 min.

Restore on AC Power Loss

This setting allows you to choose how the system will react when power returns after an unexpected loss of power. The options are Power Off, Power On and **Last State**.

MPS Revision

This setting allows the user to select the MPS revision level. The options are 1.1 and **1.4**.

This setting allows the user to select the MPS revision level. The options are 1.1 and **1.4**.

POST Debugger

Enable this setting to give the status of the AMI POST debugger in the next boot up. The options are Enabled and **Disabled**.

► Floppy/IDE/SATA Configuration

Onboard Floppy Controller

Use this setting to **Enable** or Disable the onboard floppy controller.

Floppy A

Move the cursor to these fields via up and down <arrow> keys to select the floppy type. The options are Disabled, 360 KB 5 1/4", 1.2 MB 5 1/4", 720 KB 3 1/2", **1.44 MB 3 1/2"**, and 2.88 MB 3 1/2".

Onboard IDE Controller

There is a single floppy controller on the motherboard, which may be **Enabled** or Disabled with this setting.

Serial ATA Devices

This setting is used to determine if SATA drives will be used and how many. Options are Disabled, Device 0, Device 0/1 and **Device 0/1/2**.

► nVidia RAID Setup

nVidia RAID Function

This setting is used to Enable or **Disable** the nVidia ROM. If Enabled, the setting below will appear.

SATA0/1/2 Primary/Secondary Channel

This setting is used to Enable or **Disable** the SATA0 Primary, SATA0 Secondary, SATA1 Primary, SATA1 Secondary, SATA2 Primary and SATA2 Secondary channels (six settings total).

Primary IDE Master/Slave

Highlight one of the items above and press <Enter> to access the submenu for that item.

Type

Select the type of device connected to the system. The options are Not Installed, **Auto**, CDROM and ARMD.

LBA/Large Mode

LBA (Logical Block Addressing) is a method of addressing data on a disk drive. The options are Disabled and **Auto**.

Block (Multi-Sector Transfer)

Block mode boosts IDE drive performance by increasing the amount of data transferred. Only 512 bytes of data can be transferred per interrupt if block mode is not used. Block mode allows transfers of up to 64 KB per interrupt. Select "Disabled" to allow the data to be transferred from and to the device one sector at a time. Select "Auto" to allow the data transfer from and to the device occur multiple sectors at a time if the device supports it. The options are **Auto** and Disabled.

PIO Mode

PIO (Programmable I/O) mode programs timing cycles between the IDE drive and the programmable IDE controller. As the PIO mode increases, the cycle time decreases. The options are **Auto**, 0, 1, 2, 3, and 4. Select Auto to allow AMI BIOS to auto detect the PIO mode. Use this value if the IDE disk drive support cannot be determined. Select 0 to allow AMI BIOS to use PIO mode 0. It has a data transfer rate of 3.3 MBs. Select 1 to allow AMI BIOS to use PIO mode 1. It has a data transfer rate of 5.2 MBs. Select 2 to allow AMI BIOS to use PIO mode 2. It has a data transfer rate of 8.3 MBs. Select 3 to allow AMI BIOS to use PIO mode 3. It has a data transfer rate of 11.1 MBs. Select 4 to allow AMI BIOS to use PIO mode 4. It has a data transfer rate of 16.6 MBs. This setting generally works with all hard disk drives manufactured after 1999. For other disk drives, such as IDE CD-ROM drives, check the specifications of the drive.

DMA Mode

Selects the DMA Mode. Options are **Auto**, SWDMA0, SWDMA1, SWDMA2, MWDMA0, MDWDMA1, MWDMA2, UDMA0, UDMA1, UDMA2, UDMA3, UDMA4 and UDMA5. (SWDMA=Single Word DMA, MWDMA=Multi Word DMA, UDMA=UltraDMA.)

S.M.A.R.T.

Self-Monitoring Analysis and Reporting Technology (SMART) can help predict impending drive failures. Select "Auto" to allow BIOS to auto detect hard disk drive support. Select "Disabled" to prevent AMI BIOS from using the S.M.A.R.T. Select "Enabled" to allow AMI BIOS to use the S.M.A.R.T. to support hard drive disk. The options are Disabled, Enabled, and **Auto**.

32-Bit Data Transfer

Select "Enabled" to activate the function of 32-Bit data transfer. Select "Disabled" to deactivate the function. The options are Enabled and **Disabled**.

Serial ATA0/1/2 Primary/Secondary Channel

Highlight one of the items above and press <Enter> to access the submenu for that item. If a drive is present, information on that drive will be displayed here.

LBA/Large Mode

LBA (Logical Block Addressing) is a method of addressing data on a disk drive. The options are Disabled and **Auto**.

Block (Multi-Sector Transfer)

Block mode boosts IDE drive performance by increasing the amount of data transferred. Only 512 bytes of data can be transferred per interrupt if block mode is not used. Block mode allows transfers of up to 64 KB per interrupt. Select "Disabled" to allow the data to be transferred from and to the device one sector at a time. Select "Auto" to allow the data transfer from and to the device occur multiple sectors at a time if the device supports it. The options are **Auto** and Disabled.

PIO Mode

PIO (Programmable I/O) mode programs timing cycles between the IDE drive and the programmable IDE controller. As the PIO mode increases, the cycle time

decreases. The options are **Auto**, 0, 1, 2, 3, and 4. Select Auto to allow AMI BIOS to auto detect the PIO mode. Use this value if the IDE disk drive support cannot be determined. Select 0 to allow AMI BIOS to use PIO mode 0. It has a data transfer rate of 3.3 MBs. Select 1 to allow AMI BIOS to use PIO mode 1. It has a data transfer rate of 5.2 MBs. Select 2 to allow AMI BIOS to use PIO mode 2. It has a data transfer rate of 8.3 MBs. Select 3 to allow AMI BIOS to use PIO mode 3. It has a data transfer rate of 11.1 MBs. Select 4 to allow AMI BIOS to use PIO mode 4. It has a data transfer rate of 16.6 MBs. This setting generally works with all hard disk drives manufactured after 1999. For other disk drives, such as IDE CD-ROM drives, check the specifications of the drive.

DMA Mode

Selects the DMA Mode. Options are **Auto**, SWDMA0, SWDMA1, SWDMA2, MWDMA0, MDWDMA1, MWDMA2, UDMA0, UDMA1, UDMA2, UDMA3, UDMA4 and UDMA5. (SWDMA=Single Word DMA, MWDMA=Multi Word DMA, UDMA=UltraDMA.)

S.M.A.R.T.

Self-Monitoring Analysis and Reporting Technology (SMART) can help predict impending drive failures. Select "Auto" to allow BIOS to auto detect hard disk drive support. Select "Disabled" to prevent AMI BIOS from using the S.M.A.R.T. Select "Enabled" to allow AMI BIOS to use the S.M.A.R.T. to support hard drive disk. The options are Disabled, Enabled, and **Auto**.

32-Bit Data Transfer

Select "Enabled" to activate the function of 32-Bit data transfer. Select "Disabled" to deactivate the function. The options are Enabled and **Disabled**.

► PCI/PnP Configuration

Load Onboard LAN Option ROM

Use this setting to **Enable** or Disable the onboard option ROM.

Clear NVRAM

Select Yes to clear NVRAM during boot-up. The options are Yes and **No**.

Plug & Play OS

Select Yes to allow the OS to configure Plug & Play devices. (This is not required for system boot if your system has an OS that supports Plug & Play.) Select **No** to allow AMIBIOS to configure all devices in the system.

PCI Latency Timer

This option sets the latency of all PCI devices on the PCI bus. Select a value to set the PCI latency in PCI clock cycles. Options are 32, **64**, 96, 128, 160, 192, 224 and 248.

Allocate IRQ to PCI VGA

Set this value to allow or restrict the system from giving the VGA adapter card an interrupt address. The options are **Yes** and No.

Palette Snooping

Select "Enabled" to inform the PCI devices that an ISA graphics device is installed in the system in order for the graphics card to function properly. The options are Enabled and **Disabled**.

PCI IDE BusMaster

Set this value to allow or prevent the use of PCI IDE busmastering. Select "Enabled" to allow AMI BIOS to use PCI busmaster for reading and writing to IDE drives. The options are **Disabled** and Enabled.

Offboard PCI/ISA IDE Card

This option allows the user to assign a PCI slot number to an Off-board PCI/ISA IDE card in order for it to function properly. The options are **Auto**, PCI Slot1, PCI Slot2, PCI Slot3, PCI Slot4, PCI Slot5, and PCI Slot6.

- ▶ **Advanced Chipset Control**
- ▶ **NorthBridge Configuration**
- ▶ **Memory Configuration**

Memclock Mode

This setting determines how the memory clock is set. **Auto** has the memory clock by code and **Limit** allows the user to set a standard value.

MCT Timing Mode

Sets the timing mode for memory. Options are **Auto** and **Manual**.

Bank Interleaving

Select **Auto** to automatically enable interleaving-memory scheme when this function is supported by the processor. The options are **Auto** and **Disabled**.

Enable Clock to All DIMMs

Use this setting to enable unused clocks to all DIMMSs, even if some DIMM slots are unpopulated. Options are **Enabled** and **Disabled**.

Mem Clk Tristate C3/ALTVID

Use this setting to **Enable** or **Disable** memory clock tristate during C3 and ALT VID.

CS Sparing Enable

This setting will reserve a spare memory rank in each node when enabled. Options are **Enable** and **Disable**.

DQS Signal Training Control

Turning off signal training will require custom memory timings programming. This setting will automatically be disabled when CS Sparing is enabled. The options are **Enable** and **Disable**.

Memory Hole Remapping

When "Enabled", this feature enables hardware memory remapping around the memory hole. Options are **Enabled** and **Disabled**.

► ECC Configuration

DRAM ECC Enable

DRAM ECC allows hardware to report and correct memory errors automatically. Options are **Enabled** and Disabled.

4-Bit ECC Mode

Allows the user to enable 4-bit ECC mode (also known as ECC Chipkill). Options are Enabled and **Disabled**.

DRAM Scrub Redirect

Allows system to correct DRAM ECC errors immediately, even with background scrubbing on. Options are Enabled and **Disabled**.

DRAM BG Scrub

Corrects memory errors so later reads are correct. Options are **Disabled** and various times in nanoseconds and microseconds.

L2 Cache BG Scrub

Allows L2 cache RAM to be corrected when idle. Options are **Disabled** and various times in nanoseconds and microseconds.

Data Cache BG Scrub

Allows L1 cache RAM to be corrected when idle. Options are **Disabled** and various times in nanoseconds and microseconds.

Power Down Control

Allows DIMMs to enter power down mode by deasserting the clock enable signal when DIMMs are not in use. Options are **Auto** and Disabled.

Alternate VID

Specify the alternate VID while in low power states. Options are **Auto** and various voltages from .800V to 1.150V in increments of .025V.

Memory Timing Parameters

Allows the user to select which CPU Node's timing parameters (memory clock, etc.) to display. Options are **CPU Node 0** and CPU Node1.

► SouthBridge Configuration

USB 1.1 Controller

Enable or disable the USB 1.1 controller.

USB 2.0 Controller

Enable or disable the USB 2.0 controller.

MAC0 LAN0

Settings are **Auto** and Disabled for MAC0 LAN0.

MAC0 LAN0 Bridge

Settings are **Enabled** and Disabled for MAC0 LAN0 bridge.

MAC1 LAN1

Settings are **Auto** and Disabled for MAC1 LAN1.

MAC1 LAN1 Bridge

Settings are **Enabled** and Disabled for MAC1 LAN1 bridge.

Legacy USB Support

Select "Enabled" to enable the support for USB Legacy. Disable Legacy support if there are no USB devices installed in the system. "Auto" disabled Legacy support if no USB devices are connected. The options are Disabled, **Enabled** and Auto.

PCI-E Link Select

Use this setting to select the PCI-E link. Options are **x8, x8, x4, x8** and x16, x4, x8.

► Hyper Transport Configuration

MCP55 (SB) to K8 (CPU) Freq. Auto

This setting is used for frequency selection by CPU capability. Options are **Enabled** and Disabled.

MCP55 (SB) to K8 (CPU) LinkWidth

This setting is used to select the link width. Options are 4↓ 4↑, 8↓ 8↑ and 16↓ 16↑.

► Processor & Clock Options

This submenu lists CPU information and the following settings:

MTRR Mapping

This determines the method used for programming CPU MTRRs when 4 GB or more memory is present. The options are **Continuous**, which makes the PCI hole non-cacheable, and **Discrete**, which places the PCI hole below the 4 GB boundary.

Thermal Throttling

Used to **Enable** or **Disable** thermal to generate a power management event.

Power Now

This setting is used to **Enable** or **Disable** the AMD Power Now feature.

► I/O Device Configuration

Serial Port1 Address

This option specifies the base I/O port address and Interrupt Request address of serial port 1. Select "Disabled" to prevent the serial port from accessing any system resources. When this option is set to *Disabled*, the serial port physically becomes unavailable. Select "3F8/IRQ4" to allow the serial port to use 3F8 as its I/O port address and IRQ 4 for the interrupt address. The options are Disabled, **3F8/IRQ4**, 3E8/IRQ4 and 2E8/IRQ3.

Serial Port2 Address

This option specifies the base I/O port address and Interrupt Request address of serial port 2. Select "Disabled" to prevent the serial port from accessing any system resources. When this option is set to "Disabled", the serial port physically becomes unavailable. Select "2F8/IRQ3" to allow the serial port to use 2F8 as its I/O port address and IRQ 3 for the interrupt address. The options are Disabled, **2F8/IRQ3**, 3E8/IRQ4 and 2E8/IRQ3.

Serial Port 2 Mode

Tells BIOS which mode to select for serial port 2. The options are **Normal**, IrDA and ASKIR.

► DMI Event Logging

View Event Log

Highlight this item and press <Enter> to view the contents of the event log.

Mark All Events as Read

Highlight this item and press <Enter> to mark all events as read.

Clear Event Log

Select Yes and press <Enter> to clear all event logs. The options are Yes and No to verify.

► Console Redirection

Remote Access

Allows you to Enable or **Disable** remote access. If enabled, the settings below will appear.

Serial Port Number

Selects the serial port to use for console redirection. Options are **COM1** and COM2.

Serial Port Mode

Selects the serial port settings to use. Options are **(115200 8, n, 1)**, (57600 8, n, 1), (38400 8, n, 1), (19200 8, n, 1) and (09600 8, n, 1).

Flow Control

Selects the flow control to be used for console redirection. Options are **None**, Hardware and Software.

Redirection After BIOS POST

Options are Disable (no redirection after BIOS POST), Boot Loader (redirection during POST and during boot loader) and **Always** (redirection always active). Note that some OS's may not work with this set to Always.

Terminal Type

Selects the type of the target terminal. Options are **ANSI**, VT100 and VT-UTF8.

VT-UTF8 Combo Key Support

Allows you to **Enable** or Disable VT-UTF8 combination key support for ANSI/VT100 terminals.

Sredir Memory Display Delay

Use this setting to set the delay in seconds to display memory information. Options are **No Delay**, 1 sec, 2 secs and 4 secs.

► System Health Monitor

CPU Overheat Alarm

Use the "+" and "-" keys to set the CPU temperature threshold to between 65° and 90° C. When this threshold is exceeded, the overheat LED on the chassis will light up and an alarm will sound. The LED and alarm will turn off once the CPU temperature has dropped to 5 degrees below the threshold set. The default setting is **72° C**.

► System Fan Monitor

Fan Speed Control

This feature allows the user to determine how the system will control the speed of the onboard fans. Select "Workstation" if your system is used as a Workstation. Select "Server" if your system is used as a Server. Select "Disable" to disable the fan speed control function to allow the onboard fans to continuously run at full speed (12V). The options are **1) Disable (Full Speed)** 2) 3-pin (Server) 3) 3-pin (Workstation).

FAN1 Speed through FAN8 Reading

The speeds of the onboard fans (in rpm) are displayed here.

Other items in the submenu are systems monitor displays for the following information:

CPU1 Temperature, CPU2 Temperature (for dual CPU systems), System Temperature, VCoreA, VCoreB (for dual CPU systems), HT Voltage, CPU1 Mem VTT, CPU2 Mem VTT, CPU1 Mem, CPU2 Mem, VDD, 1.5V, MCP55 VCcore, 3.3V, 12V, -12V, 5V VSB and VBAT.

▶ IPMI Configuration

▶ View BMC System Event Log

Pressing the Enter key will open the following settings. Use the "+" and "-" keys to navigate through the system event log.

Clear BMC System Event Log

Selecting this and pressing the Enter key will clear the BMC system event log.

▶ Set LAN Configuration

Use the "+" and "-" keys to choose the desired channel number.

▶ IP Address

Use the "+" and "-" keys to select the parameter. The IP address and current IP address in the BMC are shown.

▶ MAC Address

Use the "+" and "-" keys to select the parameter. The MAC address and current MAC address in the BMC are shown.

▶ Subnet Mask

Use the "+" and "-" keys to select the parameter. The subnet address and current subnet address in the BMC are shown.

▶ Set PEF Configuration

PEF Support

Use this setting to **Enable** or Disable PEF support. When enabled, the following four settings are accessible.

PEF Action Global Control

Options are **Alert**, Power Down, Reset Sysytem, Power Cycle, OEM Action and Diagnostic Int..

Alert Startup Delay

Use this setting to Enable or **Disable** the alert startup delay.

Startup Delay

Use this setting to Enable or **Disable** the startup delay.

Event Message for PEF Action

Use this setting to Enable or **Disable** event messages for a PEF action.

BMC Watch Dog Timer Action

This setting is used to set the Watch Dog function. The options are **Disabled**, Reset System, Power Down and Power Cycle.

7-4 Boot Menu

This feature allows the user to configure the following items:

▶ Boot Device Priority

This feature allows the user to prioritize the boot sequence from the available devices.

▶ Hard Disk Drives

This feature allows the user to specify the boot sequence from available hard disk drives.

▶ Removable Drives

This feature allows the user to specify the Boot sequence from available removable drives.

▶ CD/DVD Drives

This feature allows the user to specify the Boot sequence from available CD/DVD drives.

▶ Network Drives

This feature allows the user to specify the Boot sequence from available network drives.

7-5 Security Menu

AMI BIOS provides a Supervisor and a User password. If you use both passwords, the Supervisor password must be set first.

Change Supervisor Password

Select this option and press <Enter> to access the sub menu, and then type in the password.

Change User Password

Select this option and press <Enter> to access the sub menu, and then type in the password.

Boot Sector Virus Protection

This option is near the bottom of the Security Setup screen. Select "Disabled" to deactivate the Boot Sector Virus Protection. Select "Enabled" to enable boot sector protection. When "Enabled", AMI BIOS displays a warning when any program (or virus) issues a Disk Format command or attempts to write to the boot sector of the hard disk drive. The options are Enabled and **Disabled**.

7-6 Exit Menu

Select the Exit tab from AMI BIOS Setup Utility screen to enter the Exit BIOS Setup screen.

Save Changes and Exit

When you have completed the system configuration changes, select this option to leave BIOS Setup and reboot the computer, so the new system configuration parameters can take effect. Select Save Changes and Exit from the Exit menu and press <Enter>.

Discard Changes and Exit

Select this option to quit BIOS Setup without making any permanent changes to the system configuration and reboot the computer. Select Discard Changes and Exit from the Exit menu and press <Enter>.

Discard Changes

Select this option and press <Enter> to discard all the changes and return to AMI BIOS Utility Program.

Load Optimal Defaults

To load optimal default settings, select this setting and press <Enter>. Then Select "OK" to allow BIOS to automatically load the Optimal Defaults as the BIOS Settings. The Optimal settings are designed for maximum system performance, but may not work best for all computer applications.

Load Failsafe Defaults

Select and press <Enter> to load the Failsafe defaults. The Failsafe settings are designed for maximum system stability, but not maximum performance.

Appendix A

BIOS Error Beep Codes

During the POST (Power-On Self-Test) routines, which are performed each time the system is powered on, errors may occur.

Non-fatal errors are those which, in most cases, allow the system to continue the boot-up process. The error messages normally appear on the screen.

Fatal errors are those which will not allow the system to continue the boot-up procedure. If a fatal error occurs, you should consult with your system manufacturer for possible repairs.

These fatal errors are usually communicated through a series of audible beeps. The numbers on the fatal error list, on the following page, correspond to the number of beeps for the corresponding error. All errors listed, with the exception of Beep Code 8, are fatal errors.

POST codes may be read on the debug LEDs located beside the LAN port on the serverboard backplane. See the description of the Debug LEDs (LED1 and LED2) in Chapter 5.

A-1 AMIBIOS Error Beep Codes

Beep Code	Error Message	Description
1 beep	Refresh	Circuits have been reset. (Ready to power up.)
5 short, 1 long	Memory error	No memory detected in system
8 beeps	Video error	Video adapter disabled or missing

Notes

Appendix B

BIOS POST Checkpoint Codes

When AMIBIOS performs the Power On Self Test, it writes checkpoint codes to I/O port 0080h. If the computer cannot complete the boot process, diagnostic equipment can be attached to the computer to read I/O port 0080h.

B-1 Uncompressed Initialization Codes

The uncompressed initialization checkpoint codes are listed in order of execution:

Checkpoint	Code Description
D0h	The NMI is disabled. Power on delay is starting. Next, the initialization code checksum will be verified.
D1h	Initializing the DMA controller, performing the keyboard controller BAT test, starting memory refresh and entering 4 GB flat mode next.
D3h	Starting memory sizing next.
D4h	Returning to real mode. Executing any OEM patches and setting the Stack next.
D5h	Passing control to the uncompressed code in shadow RAM at E000:0000h. The initialization code is copied to segment 0 and control will be transferred to segment 0.
D6h	Control is in segment 0. Next, checking if <Ctrl> <Home> was pressed and verifying the system BIOS checksum. If either <Ctrl> <Home> was pressed or the system BIOS checksum is bad, next will go to checkpoint code E0h. Otherwise, going to checkpoint code D7h.

B-2 Bootblock Recovery Codes

The bootblock recovery checkpoint codes are listed in order of execution:

Checkpoint	Code Description
E0h	The onboard floppy controller if available is initialized. Next, beginning the base 512 KB memory test.
E1h	Initializing the interrupt vector table next.
E2h	Initializing the DMA and Interrupt controllers next.
E6h	Enabling the floppy drive controller and Timer IRQs. Enabling internal cache memory.
Edh	Initializing the floppy drive.
Eeh	Looking for a floppy diskette in drive A:. Reading the first sector of the diskette.
Efh	A read error occurred while reading the floppy drive in drive A:.
F0h	Next, searching for the AMIBOOT.ROM file in the root directory.
F1h	The AMIBOOT.ROM file is not in the root directory.
F2h	Next, reading and analyzing the floppy diskette FAT to find the clusters occupied by the AMIBOOT.ROM file.
F3h	Next, reading the AMIBOOT.ROM file, cluster by cluster.
F4h	The AMIBOOT.ROM file is not the correct size.
F5h	Next, disabling internal cache memory.
FBh	Next, detecting the type of flash ROM.
FCh	Next, erasing the flash ROM.
FDh	Next, programming the flash ROM.
FFh	Flash ROM programming was successful. Next, restarting the system BIOS.

B-3 Uncompressed Initialization Codes

The following runtime checkpoint codes are listed in order of execution.

These codes are uncompressed in F0000h shadow RAM.

Checkpoint	Code Description
03h	The NMI is disabled. Next, checking for a soft reset or a power on condition.
05h	The BIOS stack has been built. Next, disabling cache memory.
06h	Uncompressing the POST code next.
07h	Next, initializing the CPU and the CPU data area.
08h	The CMOS checksum calculation is done next.
0Ah	The CMOS checksum calculation is done. Initializing the CMOS status register for date and time next.
0Bh	The CMOS status register is initialized. Next, performing any required initialization before the keyboard BAT command is issued.
0Ch	The keyboard controller input buffer is free. Next, issuing the BAT command to the keyboard controller.
0Eh	The keyboard controller BAT command result has been verified. Next, performing any necessary initialization after the keyboard controller BAT command test.
0Fh	The initialization after the keyboard controller BAT command test is done. The keyboard command byte is written next.
10h	The keyboard controller command byte is written. Next, issuing the Pin 23 and 24 blocking and unblocking command.
11h	Next, checking if <End or <Ins> keys were pressed during power on. Initializing CMOS RAM if the Initialize CMOS RAM in every boot AMIBIOS POST option was set in AMIBCP or the <End> key was pressed.
12h	Next, disabling DMA controllers 1 and 2 and interrupt controllers 1 and 2.
13h	The video display has been disabled. Port B has been initialized. Next, initializing the chipset.
14h	The 8254 timer test will begin next.
19h	Next, programming the flash ROM.
1Ah	The memory refresh line is toggling. Checking the 15 second on/off time next.
2Bh	Passing control to the video ROM to perform any required configuration before the video ROM test.
2Ch	All necessary processing before passing control to the video ROM is done. Looking for the video ROM next and passing control to it.
2Dh	The video ROM has returned control to BIOS POST. Performing any required processing after the video ROM had control
23h	Reading the 8042 input port and disabling the MEGAKEY Green PC feature next. Making the BIOS code segment writable and performing any necessary configuration before initializing the interrupt vectors.
24h	The configuration required before interrupt vector initialization has completed. Interrupt vector initialization is about to begin.

Checkpoint	Code Description
25h	Interrupt vector initialization is done. Clearing the password if the POST DIAG switch is on.
27h	Any initialization before setting video mode will be done next.
28h	Initialization before setting the video mode is complete. Configuring the monochrome mode and color mode settings next.
2Ah	Bus initialization system, static, output devices will be done next, if present. See the last page for additional information.
2Eh	Completed post-video ROM test processing. If the EGA/VGA controller is not found, performing the display memory read/write test next.
2Fh	The EGA/VGA controller was not found. The display memory read/write test is about to begin.
30h	The display memory read/write test passed. Look for retrace checking next.
31h	The display memory read/write test or retrace checking failed. Performing the alternate display memory read/write test next.
32h	The alternate display memory read/write test passed. Looking for alternate display retrace checking next.
34h	Video display checking is over. Setting the display mode next.
37h	The display mode is set. Displaying the power on message next.
38h	Initializing the bus input, IPL, general devices next, if present. See the last page of this chapter for additional information.
39h	Displaying bus initialization error messages. See the last page of this chapter for additional information.
3Ah	The new cursor position has been read and saved. Displaying the Hit message next.
3Bh	The Hit message is displayed. The protected mode memory test is about to start.
40h	Preparing the descriptor tables next.
42h	The descriptor tables are prepared. Entering protected mode for the memory test next.
43h	Entered protected mode. Enabling interrupts for diagnostics mode next.
44h	Interrupts enabled if the diagnostics switch is on. Initializing data to check memory wraparound at 0:0 next.
45h	Data initialized. Checking for memory wraparound at 0:0 and finding the total system memory size next.
46h	The memory wraparound test is done. Memory size calculation has been done. Writing patterns to test memory next.
47h	The memory pattern has been written to extended memory. Writing patterns to the base 640 KB memory next.
48h	Patterns written in base memory. Determining the amount of memory below 1 MB next.
49h	The amount of memory below 1 MB has been found and verified.
4Bh	The amount of memory above 1 MB has been found and verified. Checking for a soft reset and clearing the memory below 1 MB for the soft reset next. If this is a power on situation, going to checkpoint 4Eh next.

Checkpoint	Code Description
4Ch	The memory below 1 MB has been cleared via a soft reset. Clearing the memory above 1 MB next.
4Dh	The memory above 1 MB has been cleared via a soft reset. Saving the memory size next. Going to checkpoint 52h next.
4Eh	The memory test started, but not as the result of a soft reset. Displaying the first 64 KB memory size next.
4Fh	The memory size display has started. The display is updated during the memory test. Performing the sequential and random memory test next.
50h	The memory below 1 MB has been tested and initialized. Adjusting the displayed memory size for relocation and shadowing next.
51h	The memory size display was adjusted for relocation and shadowing.
52h	The memory above 1 MB has been tested and initialized. Saving the memory size information next.
53h	The memory size information and the CPU registers are saved. Entering real mode next.
54h	Shutdown was successful. The CPU is in real mode. Disabling the Gate A20 line, parity, and the NMI next.
57h	The A20 address line, parity, and the NMI are disabled. Adjusting the memory size depending on relocation and shadowing next.
58h	The memory size was adjusted for relocation and shadowing. Clearing the Hit message next.
59h	The Hit message is cleared. The <WAIT...> message is displayed. Starting the DMA and interrupt controller test next.
60h	The DMA page register test passed. Performing the DMA Controller 1 base register test next.
62h	The DMA controller 1 base register test passed. Performing the DMA controller 2 base register test next.
65h	The DMA controller 2 base register test passed. Programming DMA controllers 1 and 2 next.
66h	Completed programming DMA controllers 1 and 2. Initializing the 8259 interrupt controller next.
67h	Completed 8259 interrupt controller initialization.
7Fh	Extended NMI source enabling is in progress.
80h	The keyboard test has started. Clearing the output buffer and checking for stuck keys. Issuing the keyboard reset command next.
81h	A keyboard reset error or stuck key was found. Issuing the keyboard controller interface test command next.
82h	The keyboard controller interface test completed. Writing the command byte and initializing the circular buffer next.
83h	The command byte was written and global data initialization has completed. Checking for a locked key next.
84h	Locked key checking is over. Checking for a memory size mismatch with CMOS RAM data next.
85h	The memory size check is done. Displaying a soft error and checking for a password or bypassing WINBIOS Setup next.

Checkpoint	Code Description
86h	The password was checked. Performing any required programming before WINBIOS Setup next.
87h	The programming before WINBIOS Setup has completed. Uncompressing the WINBIOS Setup code and executing the AMIBIOS Setup or WINBIOS Setup utility next.
88h	Returned from WINBIOS Setup and cleared the screen. Performing any necessary programming after WINBIOS Setup next.
89h	The programming after WINBIOS Setup has completed. Displaying the power on screen message next.
8Ch	Programming the WINBIOS Setup options next.
8Dh	The WINBIOS Setup options are programmed. Resetting the hard disk controller next.
8Fh	The hard disk controller has been reset. Configuring the floppy drive controller next.
91h	The floppy drive controller has been configured. Configuring the hard disk drive controller next.
95h	Initializing the bus option ROMs from C800 next. See the last page of this chapter for additional information.
96h	Initializing before passing control to the adaptor ROM at C800.
97h	Initialization before the C800 adaptor ROM gains control has completed. The adaptor ROM check is next.
98h	The adaptor ROM had control and has now returned control to BIOS POST. Performing any required processing after the option ROM returned control.
99h	Any initialization required after the option ROM test has completed. Configuring the timer data area and printer base address next.
9Ah	Set the timer and printer base addresses. Setting the RS-232 base address next.
9Bh	Returned after setting the RS-232 base address. Performing any required initialization before the Coprocessor test next.
9Ch	Required initialization before the Coprocessor test is over. Initializing the Coprocessor next.
9Dh	Coprocessor initialized. Performing any required initialization after the Coprocessor test next.
9Eh	Initialization after the Coprocessor test is complete. Checking the extended keyboard, keyboard ID, and Num Lock key next. Issuing the keyboard ID command next.
A2h	Displaying any soft errors next.
A3h	The soft error display has completed. Setting the keyboard typematic rate next.
A4h	The keyboard typematic rate is set. Programming the memory wait states next.
A5h	Memory wait state programming is over. Clearing the screen and enabling parity and the NMI next.
A7h	NMI and parity enabled. Performing any initialization required before passing control to the adaptor ROM at E000 next.
A8h	Initialization before passing control to the adaptor ROM at E000h completed. Passing control to the adaptor ROM at E000h next.

Checkpoint	Code Description
A9h	Returned from adaptor ROM at E000h control. Performing any initialization required after the E000 option ROM had control next.
Aah	Initialization after E000 option ROM control has completed. Displaying the system configuration next.
Abh	Uncompressing the DMI data and executing DMI POST initialization next.
B0h	The system configuration is displayed.
B1h	Copying any code to specific areas.
00h	Code copying to specific areas is done. Passing control to INT 19h boot loader next.

Notes

Appendix C

System Specifications

Processors

Single or dual AMD 64-bit Socket F, Opteron 2000 type processors

Note: Please refer to our web site for a complete listing of supported processors.

Chipset

nVidia MCP55 Pro

BIOS

8 Mb AMIBIOS® Flash ROM

Memory Capacity

Sixteen dual/single channel DIMM slots supporting up to 64 GB of DDR2-667/533/400 registered ECC SDRAM

See the memory section in Chapter 5 for details.

SATA Controller

nVidia on-chip controller for six-port Serial ATA (RAID 0, 1 0+1, 5 and JBOD supported)

SAS/SATA Drive Bays

Four (4) hot-swap drive bays to house four (4) SAS or SATA drives

Peripheral Drive Bays

One (1) slim floppy drive (optional)

One (1) slim DVD-ROM drive

Expansion Slots (see Chapter 5 for details)

CSE-R1UU-UE8 (pre-installed) riser card to support one (1) UIO card and one (1) PCI-E x8 card

Serverboard

H8DMU+ (Extended ATX form factor)

Dimensions: 12 x 13.05 in (305 x 331 mm)

Chassis

SC815TQ-R650U Form Factor: 1U rackmount

Dimensions: (WxHxD) 17 x 1.7 x 25.6 in. (432 x 43 x 650 mm)

Weight

Gross (Bare Bone): 43 lbs. (19.5 kg.)

System Cooling

Four (4) 4-cm heavy-duty counter-rotating fans

System Input Requirements

AC Input Voltage: 100-240 VAC

Rated Input Current: 8A (115V) to 4A (230V)

Rated Input Frequency: 50-60 Hz

Power Supply

Rated Output Power: 650W (Model# PWS-651-1R)

BTU Rating

3186 BTUs/hr (for rated output power of 650W)

Operating Environment

Operating Temperature: 10° to 35° C (50° to 95° F)

Non-operating Temperature: -40° to 70° C (-40° to 158° F)

Operating Relative Humidity: 8% to 90% (non-condensing)

Non-operating Relative Humidity: 5 to 95% (non-condensing)

Regulatory Compliance

Electromagnetic Emissions:

FCC Class A, EN 55022 Class A, EN 61000-3-2/-3-3, CISPR 22 Class A

Electromagnetic Immunity:

EN 55024/CISPR 24, (EN 61000-4-2, EN 61000-4-3, EN 61000-4-4,

EN 61000-4-5, EN 61000-4-6, EN 61000-4-8, EN 61000-4-11)

Safety:

EN 60950/IEC 60950-Compliant, UL Listed (USA), CUL Listed (Canada), TUV Certified (Germany), CE Marking (Europe)

California Best Management Practices Regulations for Perchlorate Materials:

This Perchlorate warning applies only to products containing CR (Manganese Dioxide) Lithium coin cells. "Perchlorate Material-special handling may apply. See www.dtsc.ca.gov/hazardouswaste/perchlorate"

Notes