

SUPERO[®]

SUPERSERVER 1025TC-T
SUPERSERVER 1025TC-10G

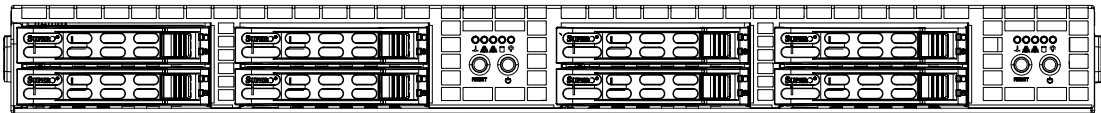

USER'S MANUAL

Revision 1.0

The information in this User's Manual has been carefully reviewed and is believed to be accurate. The vendor assumes no responsibility for any inaccuracies that may be contained in this document, makes no commitment to update or to keep current the information in this manual, or to notify any person or organization of the updates. **Please Note: For the most up-to-date version of this manual, please see our web site at www.supermicro.com.**

Super Micro Computer, Inc. ("Supermicro") reserves the right to make changes to the product described in this manual at any time and without notice. This product, including software, if any, and documentation may not, in whole or in part, be copied, photocopied, reproduced, translated or reduced to any medium or machine without prior written consent.

IN NO EVENT WILL SUPERMICRO BE LIABLE FOR DIRECT, INDIRECT, SPECIAL, INCIDENTAL, SPECULATIVE OR CONSEQUENTIAL DAMAGES ARISING FROM THE USE OR INABILITY TO USE THIS PRODUCT OR DOCUMENTATION, EVEN IF ADVISED OF THE POSSIBILITY OF SUCH DAMAGES. IN PARTICULAR, SUPERMICRO SHALL NOT HAVE LIABILITY FOR ANY HARDWARE, SOFTWARE, OR DATA STORED OR USED WITH THE PRODUCT, INCLUDING THE COSTS OF REPAIRING, REPLACING, INTEGRATING, INSTALLING OR RECOVERING SUCH HARDWARE, SOFTWARE, OR DATA.

Any disputes arising between manufacturer and customer shall be governed by the laws of Santa Clara County in the State of California, USA. The State of California, County of Santa Clara shall be the exclusive venue for the resolution of any such disputes. Super Micro's total liability for all claims will not exceed the price paid for the hardware product.

FCC Statement: This equipment has been tested and found to comply with the limits for a Class A digital device pursuant to Part 15 of the FCC Rules. These limits are designed to provide reasonable protection against harmful interference when the equipment is operated in a commercial environment. This equipment generates, uses, and can radiate radio frequency energy and, if not installed and used in accordance with the manufacturer's instruction manual, may cause harmful interference with radio communications. Operation of this equipment in a residential area is likely to cause harmful interference, in which case you will be required to correct the interference at your own expense.

California Best Management Practices Regulations for Perchlorate Materials: This Perchlorate warning applies only to products containing CR (Manganese Dioxide) Lithium coin cells. "Perchlorate Material-special handling may apply. See www.dtsc.ca.gov/hazardouswaste/perchlorate"

WARNING: Handling of lead solder materials used in this product may expose you to lead, a chemical known to the State of California to cause birth defects and other reproductive harm.

Manual Revision 1.0
Release Date: June 20, 2008

Unless you request and receive written permission from Super Micro Computer, Inc., you may not copy any part of this document.

Information in this document is subject to change without notice. Other products and companies referred to herein are trademarks or registered trademarks of their respective companies or mark holders.

Copyright © 2008 by Super Micro Computer, Inc.
All rights reserved.

Printed in the United States of America

Preface

About This Manual

This manual is written for professional system integrators and PC technicians. It provides information for the installation and use of the SuperServer 1025TC-T/1025TC-10G. Installation and maintenance should be performed by experienced technicians only.

The SuperServer 1025TC-T/1025TC-10G is a 1U Twin (two serverboards in a 1U chassis) rackmount server based on the SC809T-780B server chassis and two Super X7DCT/X7DCT-10G serverboards. The X7DCT/X7DCT-10G supports dual Intel® Xeon® 5400/5300/5200/5100 Series processors. See the Supermicro web site for details.

Manual Organization

Chapter 1: Introduction

The first chapter provides a checklist of the main components included with the server system and describes the main features of the Super X7DCT/X7DCT-10G serverboard and the SC809T-780B chassis.

Chapter 2: Server Installation

This chapter describes the steps necessary to install the SuperServer 1025TC-T/1025TC-10G into a rack and check out the server configuration prior to powering up the system. If your server was ordered without the processor and memory components, this chapter will refer you to the appropriate sections of the manual for their installation.

Chapter 3: System Interface

Refer to this chapter for details on the system interface, which includes the functions and information provided by the control panel on the chassis as well as other LEDs located throughout the system.

Chapter 4: System Safety

You should thoroughly familiarize yourself with this chapter for a general overview of safety precautions that should be followed when installing and servicing the SuperServer 1025TC-T/1025TC-10G.

Chapter 5: Advanced Serverboard Setup

Chapter 5 provides detailed information on the X7DCT/X7DCT-10G serverboard, including the locations and functions of connectors, headers and jumpers. Refer to this chapter when adding or removing processors or main memory and when reconfiguring the serverboard.

Chapter 6: Advanced Chassis Setup

Refer to Chapter 6 for detailed information on the SC809T-780B 1U rackmount server chassis. You should follow the procedures given in this chapter when installing, removing or reconfiguring SATA or peripheral drives and when replacing system power supply units and cooling fans.

Chapter 7: BIOS

The BIOS chapter includes an introduction to BIOS and provides detailed information on running the CMOS Setup Utility.

Appendix A: BIOS POST Messages

Appendix B: BIOS POST Codes

Appendix C: System Specifications

Notes

Table of Contents

Chapter 1 Introduction

1-1	Overview	1-1
1-2	Serverboard Features	1-2
	Processors	1-2
	Memory	1-2
	Serial ATA.....	1-2
	PCI Expansion Slots	1-2
	Ethernet Ports	1-2
	Onboard Controllers/Ports	1-3
	ATI Graphics Controller.....	1-3
	Other Features	1-3
1-3	Server Chassis Features	1-5
	System Power	1-5
	SATA Subsystem.....	1-5
	Control Panel	1-5
	Rear I/O Panel	1-5
	Cooling System	1-5
1-4	1U Twin: System Notes.....	1-6
	System Power	1-6
	SATA Backplane/Drives.....	1-6
1-5	Contacting Supermicro.....	1-7

Chapter 2 Server Installation

2-1	Overview	2-1
2-2	Unpacking the System	2-1
2-3	Preparing for Setup.....	2-1
	Choosing a Setup Location.....	2-1
	Rack Precautions	2-2
	Server Precautions.....	2-2
	Rack Mounting Considerations	2-3
	Ambient Operating Temperature	2-3
	Reduced Airflow	2-3
	Mechanical Loading	2-3
	Circuit Overloading.....	2-3
	Reliable Ground	2-3
2-4	Installing the Server into a Rack.....	2-4
	Identifying the Sections of the Rack Rails.....	2-4

Installing the Rack Rails	2-5
Installing the Server into a Rack.....	2-6
Installing the Server into a Telco Rack	2-7
2-5 Checking the Serverboard Setup.....	2-8
2-6 Preparing to Power On	2-9
Chapter 3 System Interface	
3-1 Overview	3-1
3-2 Control Panel Buttons	3-1
Reset.....	3-1
Power	3-1
3-3 Control Panel LEDs	3-2
Overheat/Fan Fail	3-2
NIC2	3-2
NIC1	3-2
HDD.....	3-2
Power	3-3
3-4 SATA Drive Carrier LEDs	3-3
Chapter 4 System Safety	
4-1 Electrical Safety Precautions	4-1
4-2 General Safety Precautions	4-2
4-3 ESD Precautions.....	4-3
4-4 Operating Precautions	4-4
Chapter 5 Advanced Serverboard Setup	
5-1 Handling the Serverboard	5-1
Precautions	5-1
Unpacking	5-2
5-2 Serverboard Installation	5-2
5-3 Connecting Cables.....	5-3
Connecting Data Cables	5-3
Connecting Power Cables	5-3
Connecting the Control Panel.....	5-4
5-4 I/O Ports	5-4
5-5 Processor and Heatsink Installation	5-5
Installing the Processor	5-5
Installing the Heatsink.....	5-7
Removing the Heatsink.....	5-7
5-6 Installing Memory	5-8
5-7 PCI Add-on Cards	5-10

5-8	Serverboard Details	5-11
	X7DCT/X7DCT-10G Quick Reference.....	5-12
5-9	Connector Definitions.....	5-13
5-10	Jumper Settings	5-17
5-11	Onboard Indicators.....	5-19
5-12	Installing Additional Drivers.....	5-20
5-13	Configuring Supero Doctor III	5-21

Chapter 6 Advanced Chassis Setup

6-1	Static-Sensitive Devices.....	6-1
	Precautions	6-1
	Unpacking	6-1
6-2	Control Panel	6-2
6-3	System Fans	6-3
	System Fan Failure.....	6-3
6-4	Air Shrouds	6-4
6-5	Drive Bay Installation/Removal	6-5
	Accessing the Drive Bays	6-5
6-6	Power Supply	6-7
	Power Supply Failure.....	6-7
	Replacing the Power Supply.....	6-7

Chapter 7 BIOS

7-1	Introduction.....	7-1
7-2	Running Setup	7-2
7-3	Main BIOS Setup	7-2
7-4	Advanced Setup.....	7-6
7-5	Security	7-20
7-6	Boot.....	7-22
7-7	Exit	7-23

Appendix A BIOS POST Messages

Appendix B BIOS POST Codes

Appendix C System Specifications

Chapter 1

Introduction

1-1 Overview

The SuperServer 1025TC-T/1025TC-10G is a "1U Twin" server comprised of the SC809T-780B 1U chassis and two (twin) X7DCT/X7DCT-10G serverboards. Please refer to our web site for information on operating systems that have been certified for use with the 1025TC-T/1025TC-10G (www.supermicro.com).

In addition to the serverboard and chassis, various hardware components may have been included with the 1025TC-T/1025TC-10G, as listed below.

- Four (4) CPU heatsinks (SNK-P0017)

- SATA Accessories:
 - Eight (8) SATA hard drive carriers (MCP-220-00001-03)
 - Two (2) internal SATA backplanes (BPN-SAS-809T)
 - Two (2) SATA cable sets (CBL-0201L)

- Two (2) PCI-E x16 riser cards (RSC-R1U-E16R)

- Six (6) 4-cm high-performance fans (FAN-0085L4)

- Rackmount hardware with screws (CSE-PT51L):
 - Two (2) rack rail assemblies
 - Six (6) brackets for mounting the rack rails in a rack/telco rack

- One (1) CD containing drivers and utilities

- SuperServer 1025TC-T/1025TC-10G User's Manual

1-2 Serverboard Features

At the heart of the SuperServer 1025TC-T/1025TC-10G lies two X7DCT/X7DCT-10G dual processor serverboards, which are based on Intel's 5100 chipset. Below are the main features of the X7DCT/X7DCT-10G. Note that the features on each board are doubled for the server.

Processors

Each X7DCT/X7DCT-10G supports dual Intel® Xeon® 5400/5300/5200/5100 Series processors. Please refer to our web site for a complete listing of supported processors (www.supermicro.com).

Memory

The X7DCT/X7DCT-10G has six 240-pin DIMM sockets that can support up to 48 GB of registered ECC DDR2-667/533 SDRAM. Memory can be installed in both interleaved (dual-channel) and non-interleaved (single-channel) configurations. All memory modules used to populate the system should be the same size, type and speed.

Serial ATA

The South Bridge (ICH9R) of the chipset includes a Serial ATA controller for six Gb/s SATA drives. The hot-swappable SATA drives are connected to a backplane that provides power, bus termination and configuration settings. RAID 0, 1, 5 and 10 are supported (RAID 5 is not supported by Linux OS). Refer to the support area of our web site for procedures on setting up RAID on your system.

PCI Expansion Slots

Each X7DCT/X7DCT-10G board has one PCI-Express 2.0 x16 slot, so two PCI-Express 2.0 x16 slots are provided in the server. In the 1025TC-T/1025TC-10G server configuration, riser cards have been pre-installed to support two low-profile PCI-Express x16 add-on cards.

Ethernet Ports

Two Intel® network controllers (one 82573V and one 82573L) are integrated into each of the serverboards to support a total of four Gigabit LAN ports (100/1000Base-T/1000BaseTX, RJ45 output).

Onboard Controllers/Ports

Onboard I/O backpanel ports on each serverboard include one COM port, a VGA port, two USB ports and two Gigabit LAN (NIC) ports. The 1025TC-10G (only) also has an Intel® 82598EB 10 Gb Ethernet controller with a CX4 interface. There are two sets of I/O ports included in the server (one set for each serverboard).

ATI Graphics Controller

The X7DCT/X7DCT-10G features an integrated ATI video controller based on the ES1000 graphics chip, which includes 32 MB of DDR2 memory. The ES1000 was designed specifically for servers, featuring low power consumption, high reliability and superior longevity.

Other Features

Other onboard features that promote system health include voltage monitors, a chassis intrusion header, auto-switching voltage regulators, chassis and CPU overheat sensors, virus protection and BIOS rescue.

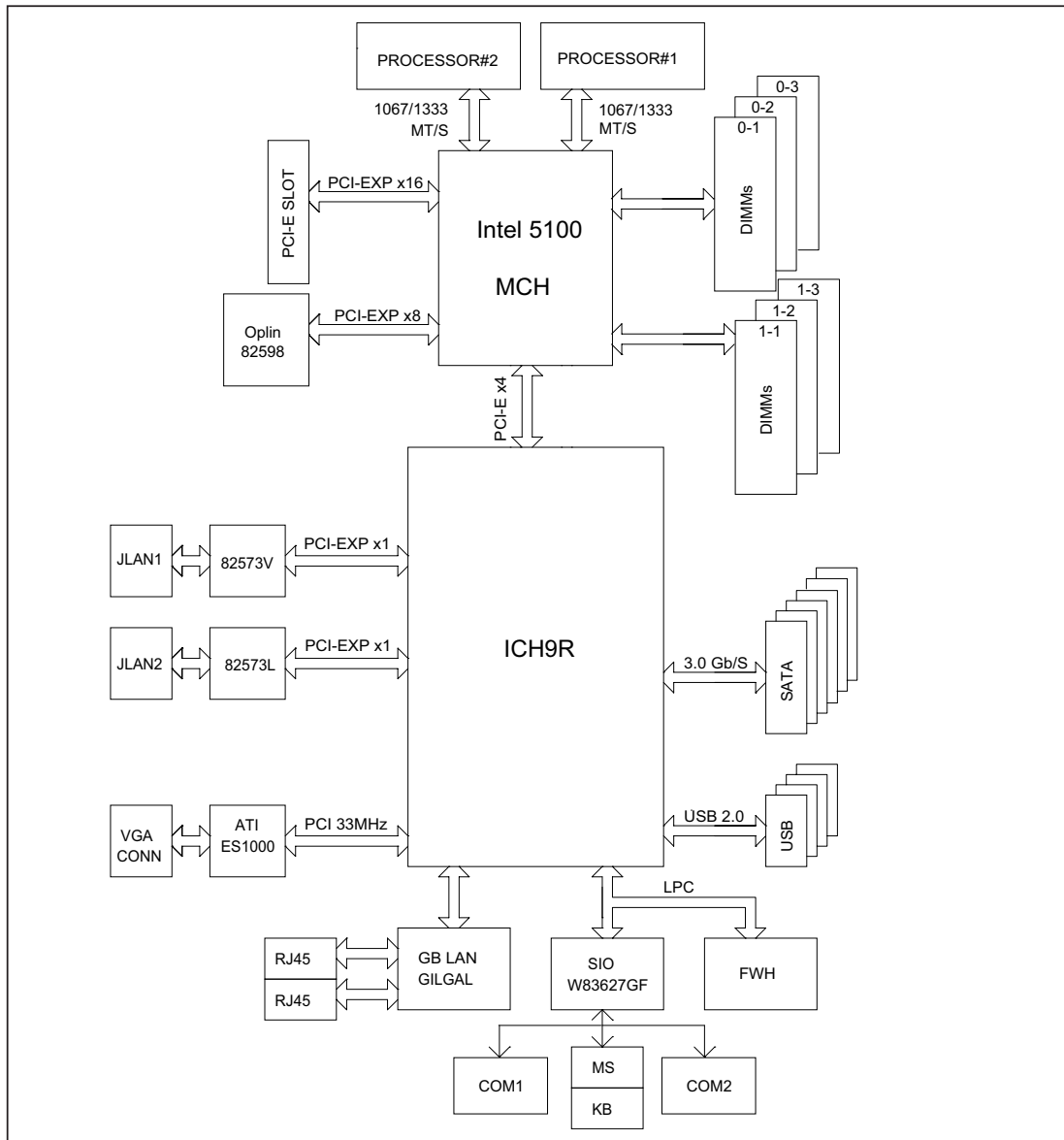

**Figure 1-1. Intel 5100 Chipset:
System Block Diagram**

Note: This is a general block diagram. Please see Chapter 5 for details.

1-3 Server Chassis Features

The following is a general outline of the main features of the SC809T-780B 1U chassis. Details on the chassis can be found in Chapter 6.

System Power

When configured as a SuperServer 1025TC-T/1025TC-10G, the SC809T-780B includes a single 780W cold-swap power supply, which provides the power to both serverboards housed in the chassis.

SATA Subsystem

The SC809T-780B chassis was designed to support eight SATA hard drives, which are hot-swappable units.

Control Panel

The SC809T-780B features two independent control panels associated with each serverboard in the chassis. Each control panel has LEDs to indicate power on, network activity, hard disk drive activity and system overheat conditions. Each control panel also includes a main power button and a system reset button.

Rear I/O Panel

The SC809T-780B is a 1U rackmount chassis. Its I/O panel provides a slots for two low-profile PCI-E x16 expansion cards, two COM ports, four USB ports, two VGA ports and four Gb Ethernet ports. The 1025TC-10G also provides two 10 Gigabit Ethernet ports. See Chapter 6 for details.

Cooling System

The SC809T-780B chassis has an innovative cooling design that features two sets of triple (for a total of six) 4-cm high-performance PWM (Pulse Width Modulated) fans. A fan speed control setting in BIOS allows fan speed to be determined by system temperature.

1-4 1U Twin: System Notes

As a 1U Twin configuration, the 1025TC-T/1025TC-10G is a unique server system. With two system boards incorporated into a single chassis, there are several points you should keep in mind.

System Power

A single power supply is used to provide the power for both serverboards. Each serverboard however, can be shut down independently of the other with the power button on its own control panel.

Although they share a common power supply, the I²C signals used for power supply monitoring are received by the primary serverboard only. (When viewed from the front of the chassis, the serverboard on the left is referred to as the primary board and the serverboard on the right as the secondary.)

SATA Backplane/Drives

As a system, the 1025TC-T/1025TC-10G supports the use of eight SATA drives. Two SATA backplanes work together as a single backplane divided into two sections. This means that while a single power connector is used and functions such as overheating apply to both sections together, each pair of SATA drives is logically connected to its own serverboard. Consequently, RAID setup is limited to a four-drive configuration (RAID cannot be spread across all eight drives).

1-5 Contacting Supermicro

Headquarters

Address: Super Micro Computer, Inc.
980 Rock Ave.
San Jose, CA 95131 U.S.A.

Tel: +1 (408) 503-8000

Fax: +1 (408) 503-8008

Email: marketing@supermicro.com (General Information)
support@supermicro.com (Technical Support)

Web Site: www.supermicro.com

Europe

Address: Super Micro Computer B.V.
Het Sterrenbeeld 28, 5215 ML
's-Hertogenbosch, The Netherlands

Tel: +31 (0) 73-6400390

Fax: +31 (0) 73-6416525

Email: sales@supermicro.nl (General Information)
support@supermicro.nl (Technical Support)
rma@supermicro.nl (Customer Support)

Asia-Pacific

Address: Super Micro Computer, Inc.
4F, No. 232-1, Liancheng Rd.
Chung-Ho 235, Taipei County
Taiwan, R.O.C.

Tel: +886-(2) 8226-3990

Fax: +886-(2) 8226-3991

Web Site: www.supermicro.com.tw

Technical Support:

Email: support@supermicro.com.tw

Tel: 886-2-8228-1366, ext.132 or 139

Notes

Chapter 2

Server Installation

2-1 Overview

This chapter provides a quick setup checklist to get your 1025TC-T/1025TC-10G up and running. Following these steps in the order given should enable you to have the system operational within a minimum amount of time. This quick setup assumes that your system has come to you with the processors and memory preinstalled. If your system is not already fully integrated with a serverboard, processors, system memory etc., please turn to the chapter or section noted in each step for details on installing specific components.

2-2 Unpacking the System

You should inspect the box the 1025TC-T/1025TC-10G was shipped in and note if it was damaged in any way. If the server itself shows damage you should file a damage claim with the carrier who delivered it.

Decide on a suitable location for the rack unit that will hold the 1025TC-T/1025TC-10G. It should be situated in a clean, dust-free area that is well ventilated. Avoid areas where heat, electrical noise and electromagnetic fields are generated. You will also need it placed near a grounded power outlet. Be sure to read the Rack and Server Precautions in the next section.

2-3 Preparing for Setup

The box the 1025TC-T/1025TC-10G was shipped in should include two sets of rail assemblies, two rail mounting brackets and the mounting screws you will need to install the system into the rack. Follow the steps in the order given to complete the installation process in a minimum amount of time. Please read this section in its entirety before you begin the installation procedure outlined in the sections that follow.

Choosing a Setup Location

- Leave enough clearance in front of the rack to enable you to open the front door completely (~25 inches).

- Leave approximately 30 inches of clearance in the back of the rack to allow for sufficient airflow and ease in servicing.
- This product is for installation only in a Restricted Access Location (dedicated equipment rooms, service closets and the like).
- This product is not suitable for use with visual display work place devices according to §2 of the the German Ordinance for Work with Visual Display Units.



Warnings and Precautions!



Rack Precautions

- Ensure that the leveling jacks on the bottom of the rack are fully extended to the floor with the full weight of the rack resting on them.
- In single rack installation, stabilizers should be attached to the rack.
- In multiple rack installations, the racks should be coupled together.
- Always make sure the rack is stable before extending a component from the rack.
- You should extend only one component at a time - extending two or more simultaneously may cause the rack to become unstable.

Server Precautions

- Review the electrical and general safety precautions in Chapter 4.
- Determine the placement of each component in the rack *before* you install the rails.
- Install the heaviest server components on the bottom of the rack first, and then work up.
- Use a regulating uninterruptible power supply (UPS) to protect the server from power surges, voltage spikes and to keep your system operating in case of a power failure.
- Allow the hot plug SATA drives and power supply modules to cool before touching them.

- Always keep the rack's front door and all panels and components on the servers closed when not servicing to maintain proper cooling.
- Make sure all power and data cables are properly connected and not blocking the chassis airflow. See Chapter 5 for details on cable connections.

Rack Mounting Considerations

Ambient Operating Temperature

If installed in a closed or multi-unit rack assembly, the ambient operating temperature of the rack environment may be greater than the ambient temperature of the room. Therefore, consideration should be given to installing the equipment in an environment compatible with the manufacturer's maximum rated ambient temperature (T_{mra}).

Reduced Airflow

Equipment should be mounted into a rack so that the amount of airflow required for safe operation is not compromised.

Mechanical Loading

Equipment should be mounted into a rack so that a hazardous condition does not arise due to uneven mechanical loading.

Circuit Overloading

Consideration should be given to the connection of the equipment to the power supply circuitry and the effect that any possible overloading of circuits might have on overcurrent protection and power supply wiring. Appropriate consideration of equipment nameplate ratings should be used when addressing this concern.

Reliable Ground

A reliable ground must be maintained at all times. To ensure this, the rack itself should be grounded. Particular attention should be given to power supply connections other than the direct connections to the branch circuit (i.e. the use of power strips, etc.).

2-4 Installing the Server into a Rack

This section provides information on installing the 1025TC-T/1025TC-10G into a rack unit with the rack rails provided. If the system has already been mounted into a rack, you can skip ahead to Sections 2-5 and 2-6.

There are a variety of rack units on the market, which may mean the assembly procedure will differ slightly. You should also refer to the installation instructions that came with the rack unit you are using.

Note: This rail will fit a rack between 26" and 33.5" deep.

Identifying the Sections of the Rack Rails

You should have received two rack rail assemblies in the rack mounting kit. Each assembly consists of two sections: an inner fixed chassis rail that secures directly to the server chassis and an outer fixed rack rail that secures directly to the rack itself (see Figure 2-1).

**Figure 2-1. Identifying the Sections of the Rack Rails
(right side rail shown)**

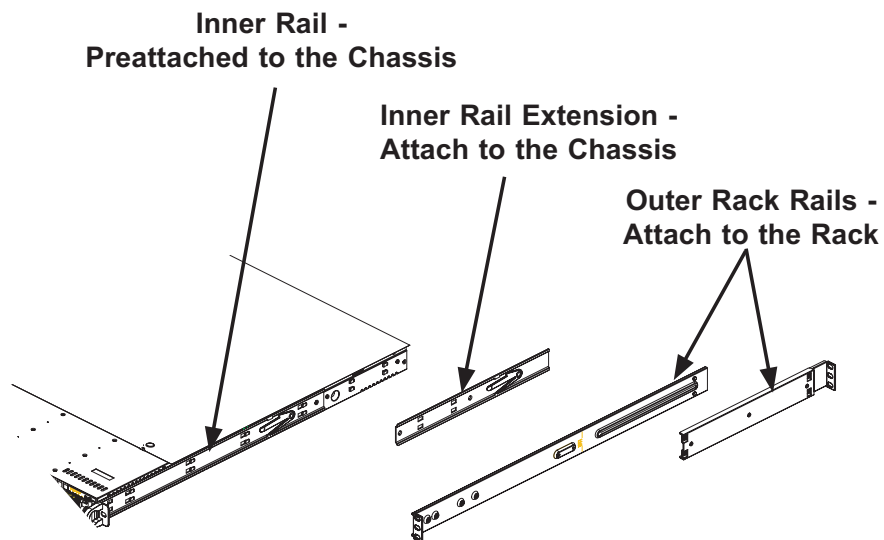

Installing the Rack Rails

The SC809 chassis includes a set of inner rack rails in two sections: inner rails (A) and inner rail extensions (B). The inner rails are preattached and do not interfere with normal use of the chassis if you decide not to use a server rack. Attach the inner rail extensions to the inner rails, to stabilize the chassis within the rack.

Installing the Inner Rail Extensions (Figure 2-2)

1. Place the inner rail extensions (B) over the preattached inner rails (A) which are attached to the side of the chassis. Align the hooks of the inner rail with the rail extension holes. Make sure the extension faces "outward" just like the inner rail.
2. Slide the extension toward the front of the chassis.
3. Secure the chassis with screws as illustrated.
4. Repeat steps 1-3 for the other inner rail extension.

Figure 2-2: Installing the Inner Rail Extensions

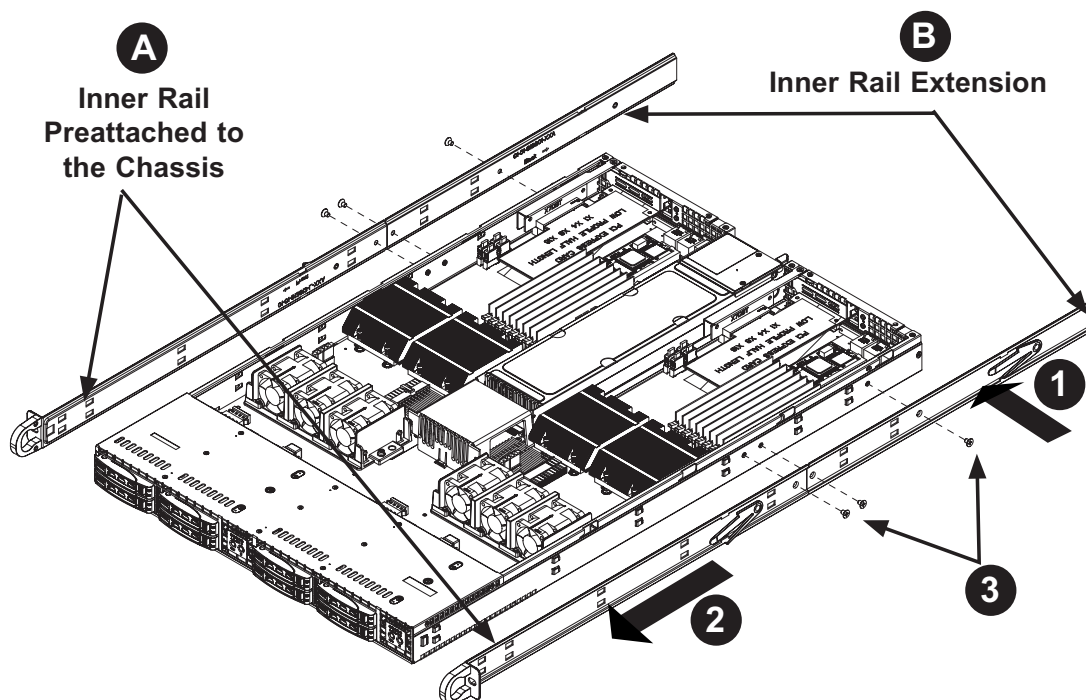

Installing the Outer Rails to the Rack

1. Attach the short bracket to the outside of the long bracket. You must align the pins with the slides. Also, both bracket ends must face the same direction.
2. Adjust both the short and long brackets to the proper distance so that the rail fits snugly into the rack.
3. Secure the long bracket to the front side of the outer rail with two M5 screws and the short bracket to the rear side of the outer rail with three M5 screws.
4. Repeat steps 1-4 for the left outer rail.

Figure 2-3: Assembling the Outer Rails

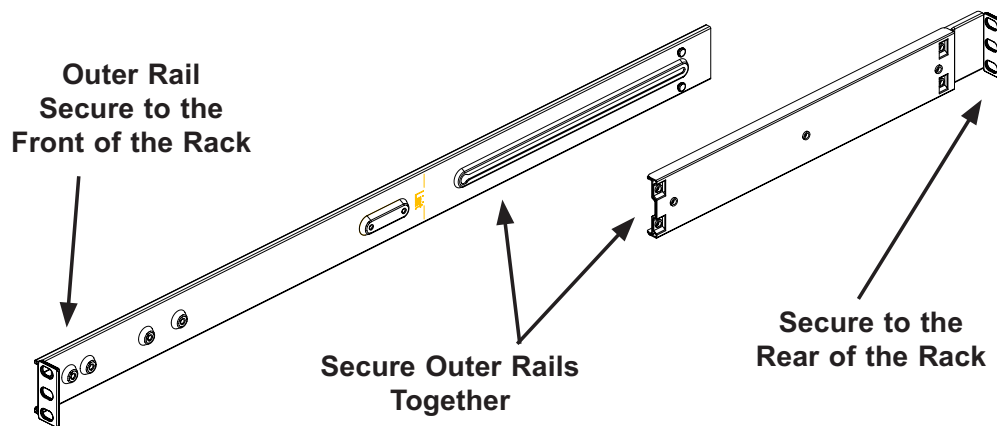

Installing the Server into a Rack

1. Confirm that chassis includes the inner rails (attached to the chassis beneath the rail extensions) and rail extensions (B). Also, confirm that the outer rails (C) are installed on the rack.
2. Align the chassis rails extensions (B), with the front of the rack rails (C).
3. Slide the chassis rail extensions into the rack rails, keeping the pressure even on both sides (you may have to depress the locking tabs when inserting). When the server has been pushed completely into the rack, you should hear the locking tabs "click" into position.
4. (Optional) Insert and tightening the thumbscrews that hold the front of the server to the rack.

Figure 2-4: Installing the Rack Rails

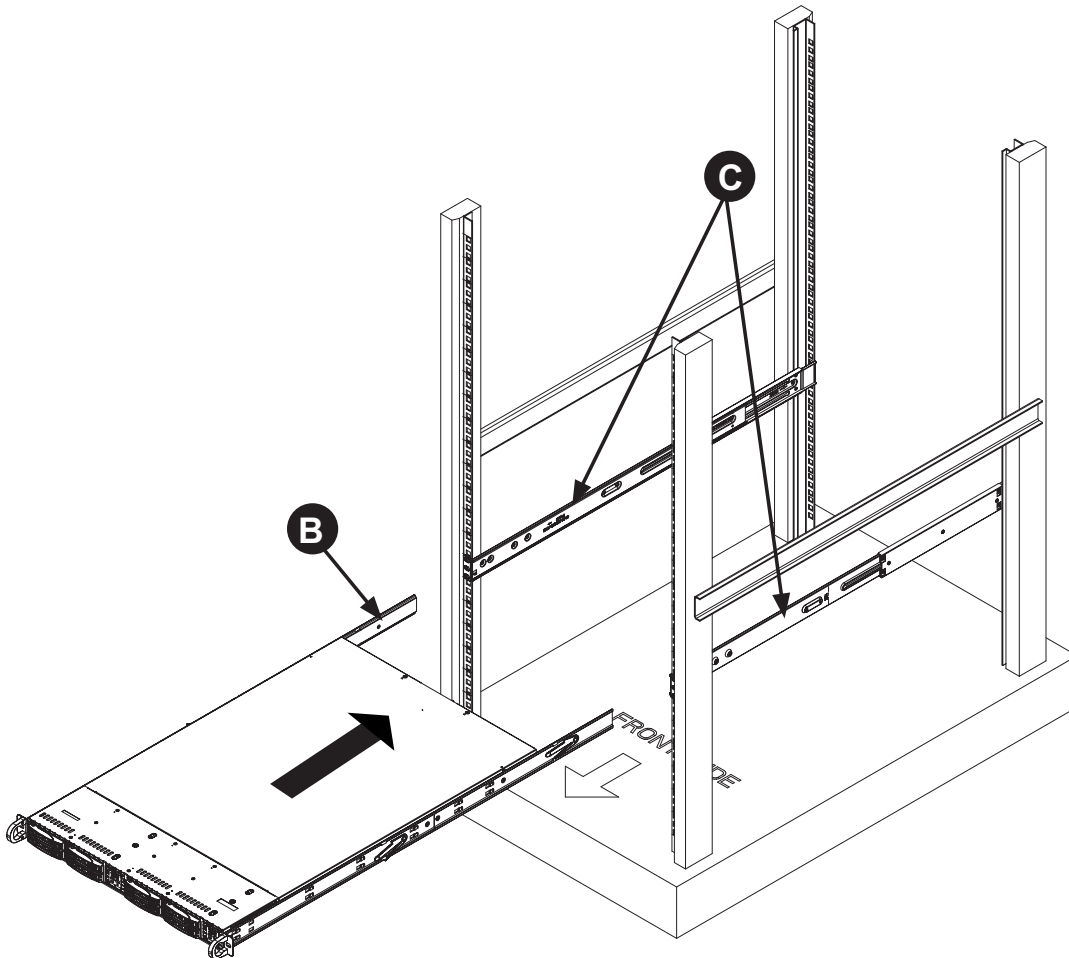

Installing the Server into a Telco Rack

To install the SuperServer 1025TC-T/1025TC-10G into a Telco type rack, use two L-shaped brackets on either side of the chassis (four total). First, determine how far the server will extend out the front of the rack. Larger chassis should be positioned to balance the weight between front and back. If a bezel is included on your server, remove it. Then attach the two front brackets to each side of the chassis, then the two rear brackets positioned with just enough space to accommodate the width of the rack. Finish by sliding the chassis into the rack and tightening the brackets to the rack.

2-5 Checking the Serverboard Setup

After you install the 1025TC-T/1025TC-10G in the rack, you will need to open the top cover to make sure the serverboard is properly installed and all the connections have been made.

Accessing the Inside of the System (Figure 2-5)

To access the system, first grasp the two handles on either side and pull the system straight out until it locks (you will hear a "click").

1. Remove the two screws securing the cover to the sides of the chassis.
2. Remove the two screws securing the cover to the back of the chassis.
3. Slide the cover toward the rear of the chassis
4. Lift the cover off the chassis.
5. To remove the system from the rack completely, depress the locking tabs in the chassis rails (push the right-side tab down and the left-side tab up) to continue to pull the system out past the locked position.

Checking the Components and Setup

1. You may have one or two processors already installed in each of the two serverboards. Each processor needs its own heatsink. See Chapter 5 for instructions on processor and heatsink installation.
2. Your server system may have come with system memory already installed. Make sure all DIMMs are fully seated in their slots. For details on adding system memory, refer to Chapter 5.
3. You can install two add-on cards to the system. See Chapter 5 for details on installing PCI add-on cards.
4. Make sure all power and data cables are properly connected and not blocking the chassis airflow. See Chapter 5 for details on cable connections.

2-6 Preparing to Power On

Next, you should check to make sure the peripheral drives and the SATA drives and SATA backplane have been properly installed and all connections have been made.

Checking the SATA drives

1. The SATA disk drives are accessible from the front of the server and can be installed and removed from the front of the chassis without removing the top chassis cover.
2. Depending upon your system's configuration, your system may have one or more drives already installed. If you need to install SATA drives, please refer to Chapter 6.

Checking the Airflow

1. Airflow is provided by six sets of 4-cm PWM fans (each set of fans consists of two fans that are mounted back to back) and an air shroud. The system component layout was carefully designed to direct sufficient cooling airflow to the components that generate the most heat.
2. Note that all power and data cables have been routed in such a way that they do not block the airflow generated by the fans.

Providing Power

1. Plug the power cords from the power supplies unit into a high-quality power strip that offers protection from electrical noise and power surges.
2. It is recommended that you use an uninterruptible power supply (UPS).
3. Finally, depress the power on button on the front of the chassis.

Figure 2-5. Accessing the Inside of the System

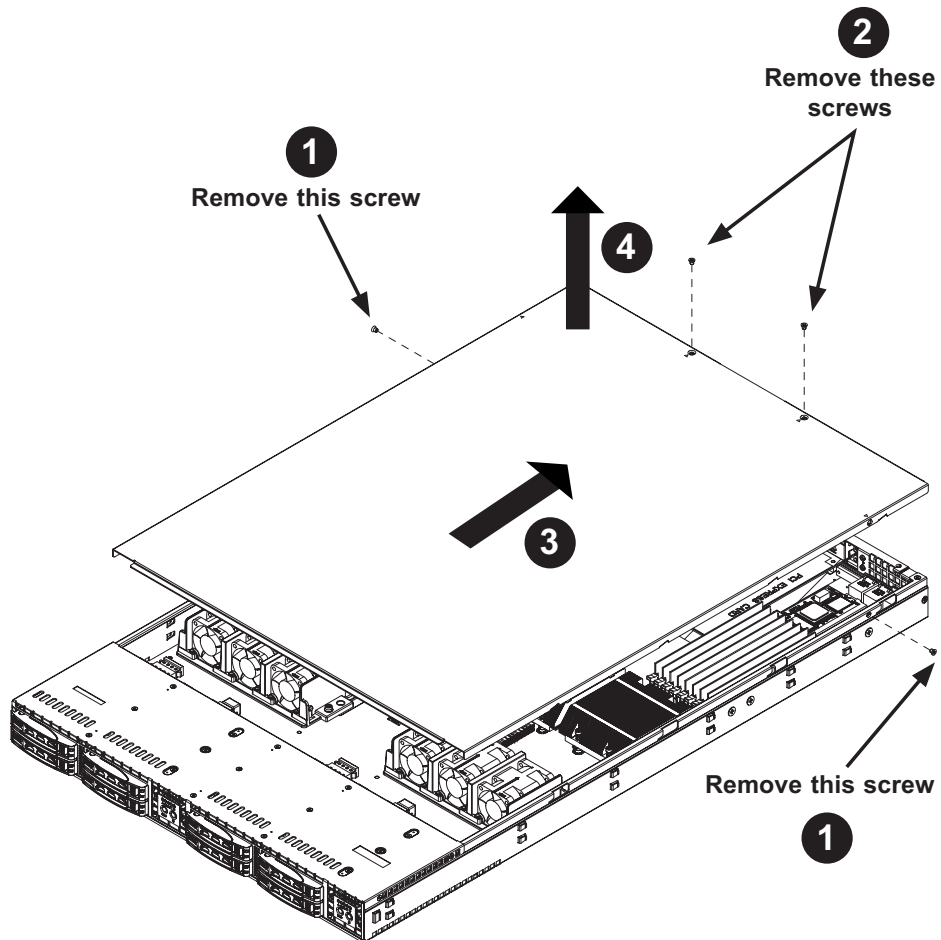

Chapter 3

System Interface

3-1 Overview

There are several LEDs on the two control panels and on the SATA drive carriers to keep you constantly informed of the overall status of the system as well as the activity and health of specific components. There are also two buttons on each control panel. This chapter explains the meanings of all LED indicators and the appropriate response you may need to take. Note that the server has two control panels, one for each serverboard installed in the system. This allows each serverboard to be controlled independently of the other.

3-2 Control Panel Buttons

There are two push-buttons located on each control panel: a reset button and a power on/off button.

RESET

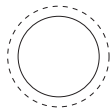

Reset

Depressing the reset button will reboot only the serverboard it is associated with.



Power

This is the main power button, which is used to apply or turn off the main system power only to the serverboard it is connected to. Depressing this button removes the main power but keeps standby power supplied to the serverboard.

3-3 Control Panel LEDs

Each of the two control panels located on the front of the SC809T-780B chassis has five LEDs. Each LED provides you with critical information related its own specific serverboard. This section explains what each LED indicates when illuminated and any corrective action you may need to take.



Overheat/Fan Fail

When this LED flashes, it indicates a fan failure. When on continuously it indicates an overheat condition, which may be caused by cables obstructing the airflow in the system or the ambient room temperature being too warm. Check the routing of the cables and make sure all fans are present and operating normally. You should also check to make sure that the chassis covers are installed. Finally, verify that the heatsinks are installed properly (see Chapter 5). This LED will remain flashing or on as long as the indicated condition exists.



NIC2

Indicates network activity on LAN2 when flashing



NIC1

Indicates network activity on LAN1 when flashing.



HDD

Channel activity for the hard disk drives. This light indicates SATA drive activity on the 1025TC-T/1025TC-10G when flashing.



Power

Indicates power is being supplied to the system's power supply unit. This LED should normally be illuminated when the system is operating.

3-4 SATA Drive Carrier LEDs

Each SATA drive carrier has two LEDs.

- **Green:** When illuminated, the green LED on the front of the SATA drive carrier indicates drive activity. A connection to the SATA backplane enables this LED to blink on and off when that particular drive is being accessed.
- **Red:** There is no function associated with the red LED.

Notes

Chapter 4

System Safety

4-1 Electrical Safety Precautions



Basic electrical safety precautions should be followed to protect yourself from harm and the SuperServer 1025TC-T/1025TC-10G from damage:

- Be aware of the locations of the power on/off switch on the chassis as well as the room's emergency power-off switch, disconnection switch or electrical outlet. If an electrical accident occurs, you can then quickly remove power from the system.
- Do not work alone when working with high voltage components.
- Power should always be disconnected from the system when removing or installing main system components, such as the serverboard, memory modules and floppy drive. When disconnecting power, you should first power down the system with the operating system first and then unplug the power cords of all the power supply units in the system.
- When working around exposed electrical circuits, another person who is familiar with the power-off controls should be nearby to switch off the power if necessary.
- Use only one hand when working with powered-on electrical equipment. This is to avoid making a complete circuit, which will cause electrical shock. Use extreme caution when using metal tools, which can easily damage any electrical components or circuit boards they come into contact with.
- Do not use mats designed to decrease static electrical discharge as protection from electrical shock. Instead, use rubber mats that have been specifically designed as electrical insulators.
- The power supply power cords must include a grounding plug and must be plugged into grounded electrical outlets.

- Serverboard Battery: **CAUTION** - There is a danger of explosion if the onboard battery is installed upside down, which will reverse its polarities (see Figure 4-1). This battery must be replaced only with the same or an equivalent type recommended by the manufacturer. Dispose of used batteries according to the manufacturer's instructions.
- DVD-ROM Laser: **CAUTION** - this server may have come equipped with a DVD-ROM drive. To prevent direct exposure to the laser beam and hazardous radiation exposure, do not open the enclosure or use the unit in any unconventional way.
- Mainboard replaceable soldered-in fuses: Self-resetting PTC (Positive Temperature Coefficient) fuses on the mainboard must be replaced by trained service technicians only. The new fuse must be the same or equivalent as the one replaced. Contact technical support for details and support.

4-2 General Safety Precautions



Follow these rules to ensure general safety:

- Keep the area around the 1025TC-T/1025TC-10G clean and free of clutter.
- The 1025TC-T/1025TC-10G weighs approximately 40 lbs (~18.2 kg) when fully loaded. When lifting the system, two people at either end should lift slowly with their feet spread out to distribute the weight. Always keep your back straight and lift with your legs.
- Place the chassis top cover and any system components that have been removed away from the system or on a table so that they won't accidentally be stepped on.
- While working on the system, do not wear loose clothing such as neckties and unbuttoned shirt sleeves, which can come into contact with electrical circuits or be pulled into a cooling fan.
- Remove any jewelry or metal objects from your body, which are excellent metal conductors that can create short circuits and harm you if they come into contact with printed circuit boards or areas where power is present.

- After accessing the inside of the system, close the system back up after ensuring that all connections have been made.

4-3 ESD Precautions



Electrostatic discharge (ESD) is generated by two objects with different electrical charges coming into contact with each other. An electrical discharge is created to neutralize this difference, which can damage electronic components and printed circuit boards. The following measures are generally sufficient to neutralize this difference before contact is made to protect your equipment from ESD:

- Use a grounded wrist strap designed to prevent static discharge.
- Keep all components and printed circuit boards (PCBs) in their antistatic bags until ready for use.
- Touch a grounded metal object before removing the board from the antistatic bag.
- Do not let components or PCBs come into contact with your clothing, which may retain a charge even if you are wearing a wrist strap.
- Handle a board by its edges only; do not touch its components, peripheral chips, memory modules or contacts.
- When handling chips or modules, avoid touching their pins.
- Put the serverboard and peripherals back into their antistatic bags when not in use.
- For grounding purposes, make sure your computer chassis provides excellent conductivity between the power supply, the case, the mounting fasteners and the serverboard.

4-4 Operating Precautions



Care must be taken to assure that the chassis cover is in place when the 1025TC-T/1025TC-10G is operating to assure proper cooling. Out of warranty damage to the system can occur if this practice is not strictly followed.

Figure 4-1. Installing the Onboard Battery

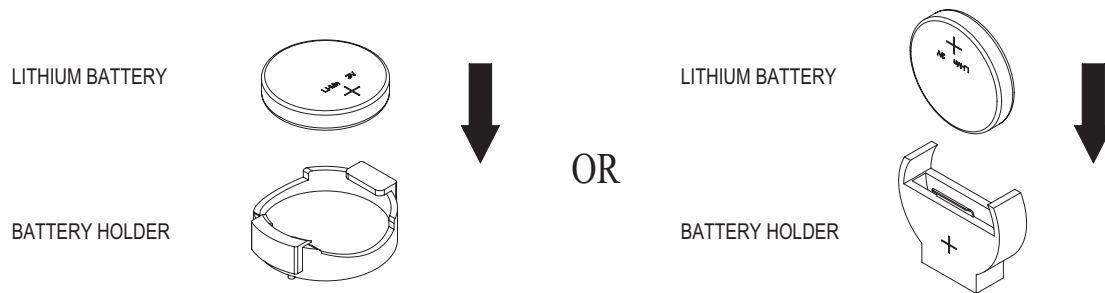

Chapter 5

Advanced Serverboard Setup

This chapter covers the steps required to install the X7DCT/X7DCT-10G serverboard into the SC809T-780B chassis, connect the data and power cables and install add-on cards. All serverboard jumpers and connections are also described. A layout and quick reference chart are included in this chapter for your reference. Remember to completely close the chassis when you have finished working with the serverboard to better cool and protect the system.

5-1 Handling the Serverboard

Electrostatic discharge (ESD) can damage electronic components. To prevent damage to any printed circuit boards (PCBs), it is important to handle them very carefully (see previous chapter). To prevent the X7DCT/X7DCT-10G serverboard from bending, keep one hand under the center of the board to support it when handling. The following measures are generally sufficient to protect your equipment from electric static discharge.

Precautions

- Use a grounded wrist strap designed to prevent Electrostatic Discharge (ESD).
- Touch a grounded metal object before removing any board from its antistatic bag.
- Handle a board by its edges only; do not touch its components, peripheral chips, memory modules or gold contacts.
- When handling chips or modules, avoid touching their pins.
- Put the serverboard, add-on cards and peripherals back into their antistatic bags when not in use.
- For grounding purposes, make sure your computer chassis provides excellent conductivity between the power supply, the case, the mounting fasteners and the serverboard.

Unpacking

The serverboard is shipped in antistatic packaging to avoid electrostatic discharge. When unpacking the board, make sure the person handling it is static protected.

5-2 Serverboard Installation

This section explains the first step of physically mounting the X7DCT/X7DCT-10G into the SC809T-780B chassis. Following the steps in the order given will eliminate the most common problems encountered in such an installation. To remove the serverboard, follow the procedure in reverse order.

Accessing the Inside of the System

1. Remove all four screws securing the top cover of the chassis: two at the top rear of the cover and one on each side lip, also near the back.
2. Place both thumbs in the indentations and push the cover back until it slides off.
3. Lift the top cover from the chassis to gain full access to the inside of the server. (If already installed in a rack, grasp the two handles on either side and pull the unit straight out until the rails lock into place. See Figure 2-5.)

Check Compatibility of Serverboard Ports and I/O Shield

1. The X7DCT/X7DCT-10G in a Twin 1U configuration requires the use of Supermicro's specially designed 1U Twin chassis: the SC809T-780B.
2. Make sure that the I/O ports on the serverboards align properly with their respective holes in the I/O shield at the back of the chassis when installing.

Mounting the Serverboard onto the Serverboard Tray

1. Carefully mount the serverboards by aligning the board holes with the raised metal standoffs that are visible in the chassis.
2. Insert screws into all the mounting holes on your serverboards that line up with the standoffs and tighten until snug (if you screw them in too tight, you might strip the threads).
3. Metal screws provide an electrical contact to the serverboard ground to provide a continuous ground for the system.

5-3 Connecting Cables

Now that the serverboards are installed, the next step is to connect the cables to the boards. These include the data cables for the peripherals and control panel and the power cables.

Connecting Data Cables

The cables used to transfer data from the peripheral devices have been carefully routed to prevent them from blocking the flow of cooling air that moves through the system from front to back. If you need to disconnect any of these cables, you should take care to keep them routed as they were originally after reconnecting them (make sure the red wires connect to the pin 1 locations). The following data cables (with their locations noted) should be connected. (See the serverboard layout for connector locations.) Note that each connection listed should be made for both serverboards in the chassis.

- SATA drive cables (SATA0 ~ SATA3)
- Control Panel cable (JF1)

Connecting Power Cables

The X7DCT/X7DCT-10G has two 20-pin ATX power supply connectors for connection to the ATX power supply. Only one of these from each board should be connected to the power supply. The "Primary ATX Power Header" is used to supply power to the primary serverboard and the "Secondary ATX Power Header" is used to supply power to the secondary serverboard. Connect the power supply to only one of these on both boards (primary = left, secondary = right when viewed from front of server). See Section 5-9 for power connector pin definitions.

Connecting the Control Panel

JF1 contains header pins for various front control panel connectors. See Figure 5-1 for the pin locations of the various front control panel buttons and LED indicators. All JF1 wires have been bundled into a single ribbon cable to simplify this connection. Make sure the red wire plugs into pin 1 as marked on the board. The other end connects to the Control Panel PCB board, located just behind the system status LEDs on the chassis.

Figure 5-1. Control Panel Header Pins

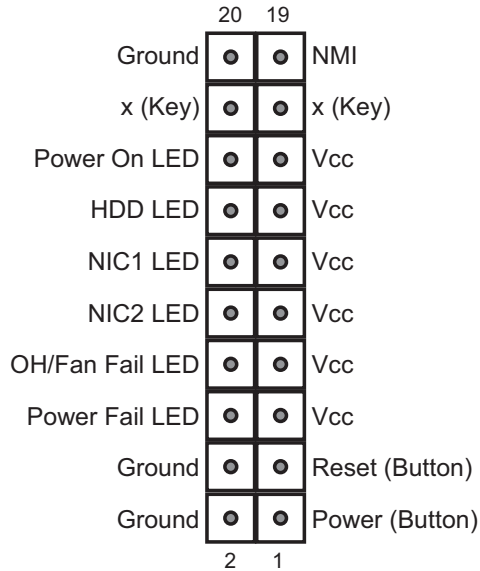

5-4 I/O Ports

The I/O ports are color coded in conformance with the PC 99 specification. See Figure 5-2 below for the colors and locations of the various I/O ports.

Figure 5-2. I/O Ports

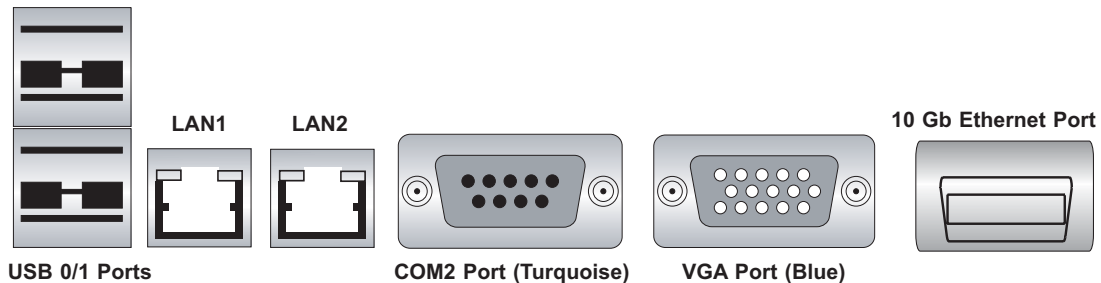

Note: The 10 Gb Ethernet port is included on the X7DCT-10G (1025TC-10G) only.

5-5 Processor and Heatsink Installation



When handling the processor, avoid placing direct pressure on the label area of the fan. Also, do not place the serverboard on a conductive surface, which can damage the BIOS battery and prevent the system from booting up.

IMPORTANT! Always connect the power cord last and remove it first before adding, removing or changing any hardware components. Make sure that you install the processor into the CPU socket *before* you install the heatsink and fan. The X7DCT/X7DCT-10G can support either one or two processors. If installing one processor only, install it into the CPU1 socket.

Notes:

1. Intel's boxed Xeon CPU package contains a CPU fan and heatsink assembly. If you buy a CPU separately, make sure that you use only Intel-certified multi-directional heatsinks and fans.
2. When purchasing a Xeon CPU or when receiving a serverboard with a CPU pre-installed, make sure that the CPU plastic cap is in place and none of the CPU pins are bent; otherwise, contact the retailer immediately.

Installing the Processor

1. A black PnP cap is attached to the load plate to protect the CPU socket. Press the load lever down and away from the retention clasp to release the load plate from its locked position.

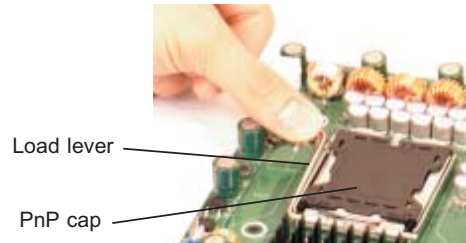

2. Gently lift the load lever to open the load plate.

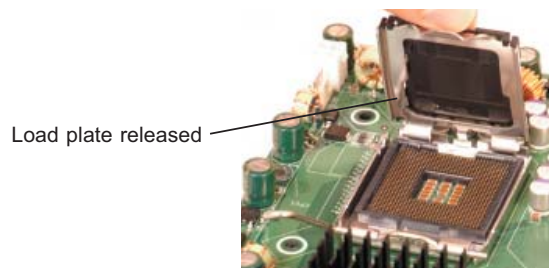

3. Use your thumb and your index finger to hold the CPU at opposite sides.

4. Align pin1 of the CPU (the corner marked with a triangle) with the notched corner of the CPU socket.

5. Find the corner of the CPU that has a semi-circle cutout below a gold dot (CPU key). This corner should be aligned with the cutout on the socket (socket key).

6. Once aligned, carefully lower the CPU straight down into the socket. Do not drop the CPU on the socket, do not move the CPU horizontally or vertically and do not rub the CPU against any surface or any of the contacts, which may damage the CPU and/or contacts.

7. With the CPU in the socket, inspect the four corners of the CPU to make sure that it is properly installed.

8. Use your thumb to gently push the load lever down until it snaps into the retention clasp.

9. If the CPU is properly installed into the socket, the PnP cap will be automatically released from the load plate when the lever locks. Repeat steps to install a second CPU if desired.

Warning! Keep the plastic PnP cap. The serverboard must be shipped with the PnP cap properly installed to protect the CPU socket. Shipment without the PnP cap properly installed will void the warranty.

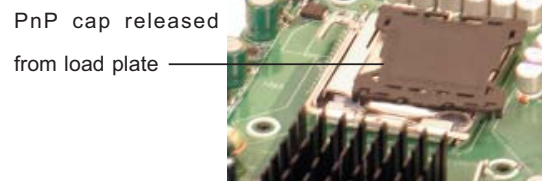
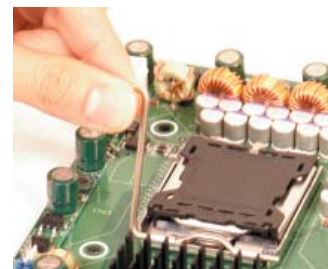
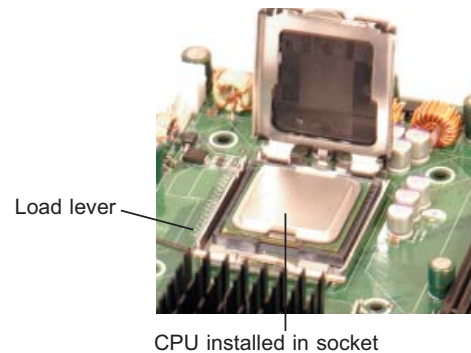
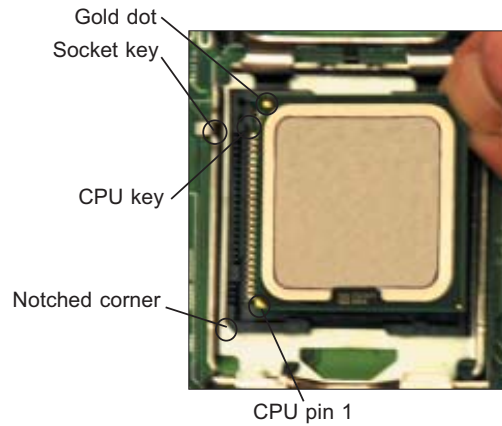

Installing the Heatsink

1. Do not apply any thermal grease to the heatsink or the CPU die; the required amount has already been applied.

2. Place the heatsink on top of the CPU so that the four mounting holes are aligned with those on the (preinstalled) heatsink retention mechanism.

3. Screw in two diagonal screws (i.e. the #1 and the #2 screws) until just snug. Do not fully tighten the screws or you may damage the CPU.)

4. Add the two remaining screws then finish the installation by fully tightening all four screws.

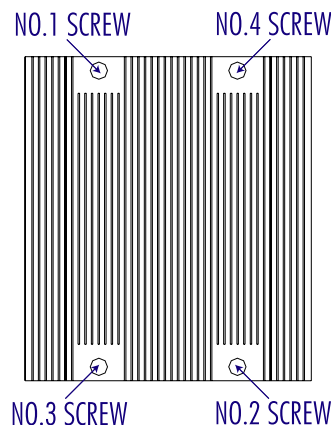

Removing the Heatsink



Warning! We do not recommend that the CPU or the heatsink be removed. However, if you do need to uninstall the heatsink, please follow the instructions below to prevent damage to the CPU or the CPU socket.

1. Unscrew and remove the heatsink screws from the serverboard in the sequence as show in the picture above.
2. Hold the heatsink and gently wriggle the heatsink to loosen it from the CPU. (Do not use excessive force when wriggling the heatsink!!)
3. Once the heatsink is loose, remove it from the CPU.
4. Clean the surface of the CPU and the heatsink to get rid of the old thermal grease. Reapply the proper amount of thermal grease on the surface before you re-install the heatsink.

5-6 Installing Memory



CAUTION! Exercise extreme care when installing or removing DIMM modules to prevent any possible damage.

Memory Support

The X7DCT/X7DCT-10G has six 240-pin DIMM slots that can support up to 48 GB of registered ECC DDR2-667/533 SDRAM (for a total of 96 GB in the system).

The memory scheme is interleaved, so you must populate two slots at a time, beginning with slot 1A and 1B, then slots 2A and 2B, and finally into slots 3A and 3B if six DIMMs are to be installed. See table below.

Installing Memory Modules

1. Insert each memory module vertically, beginning with slots 1A and 1B (see above). Pay attention to the notches along the bottom of the module to prevent inserting it incorrectly.
2. Gently press down on the DIMM module until it snaps into place in the slot (see Figure 5-3).
3. Repeat to install a total of four or six DIMMs if needed.

Note: Due to allocating memory to system devices, memory remaining available for operational use will be reduced when 4 GB of SDRAM is used. The reduction in memory availability is disproportional. (Refer to the Memory Availability Table on the following page for details.)

Optimized DIMM Configurations						
No. of DIMMs	Channel 0			Channel 1		
2	DIMM1A	-----	-----	DIMM1B	-----	-----
4	DIMM1A	DIMM2A	-----	DIMM1B	DIMM2B	-----
6	DIMM1A	DIMM2A	DIMM3A	DIMM1B	DIMM2B	DIMM3B

Notes: i. DIMM slot# specified = DIMM slot to be populated; "----" = DIMM slot not to be populated. ii. Both 533 MHz and 667MHz memory is supported; however, you need to use modules of the same speed and type. iii. For memory to work properly, you need to follow the restrictions listed above.

Figure 5-3. DIMM Installation

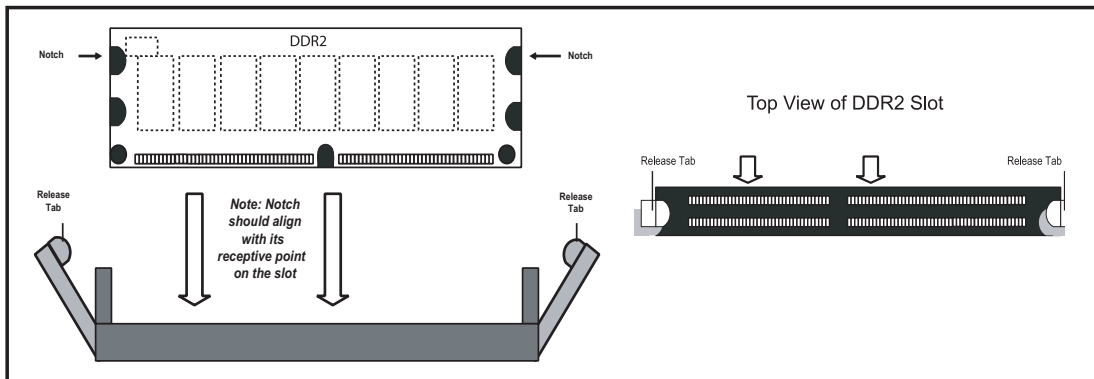

To Install: Insert module vertically and press down until it snaps into place. Pay attention to the bottom notches.

To Remove: Use your thumbs to gently push each release tab outward to free the DIMM from the slot.

Possible System Memory Allocation & Availability			
System Device	Size	Physical Memory Remaining (Available) (3 GB Total System Memory)	Physical Memory Remaining (Available) (4 GB Total System Memory)
Firmware Hub flash memory (System BIOS)	1 MB	3.00	3.99
Local APIC	4 KB	3.00	3.99
Area Reserved for the chipset	2 MB	3.00	3.99
I/O APIC (4 Kbytes)	4 KB	3.00	3.99
PCI Enumeration Area 1	256 MB	3.00	3.76
PCI Express (256 MB)	256 MB	3.00	3.51
PCI Enumeration Area 2 (if needed) -Aligned on 256-MB boundary-	512 MB	3.00	3.01
VGA Memory	16 MB	2.85	2.85
TSEG	1 MB	2.84	2.84
Memory available to OS & other applications		2.84	2.84

5-7 PCI Add-on Cards

The system includes two preinstalled riser cards designed for use in the SC809T-780B chassis. These riser cards support two low-profile PCI-Express x16 cards.

Installing PCI Add-on Cards:

1. Disconnect the power supply and open the chassis cover.
2. Pull open the add-on card slot clip at the rear of the chassis.
3. Slide the temporary add-on card "L" bracket toward the slot clip and remove the temporary bracket from the chassis.
4. Connect the add-on card to the riser card and slide the add-on card "L" bracket in to the rear add-on card slot.
5. Close the add-on card slot clip.

Note: Under normal circumstances, the riser card and add-on card bracket are not separated.

Figure 5-4: Installing Add-on Cards

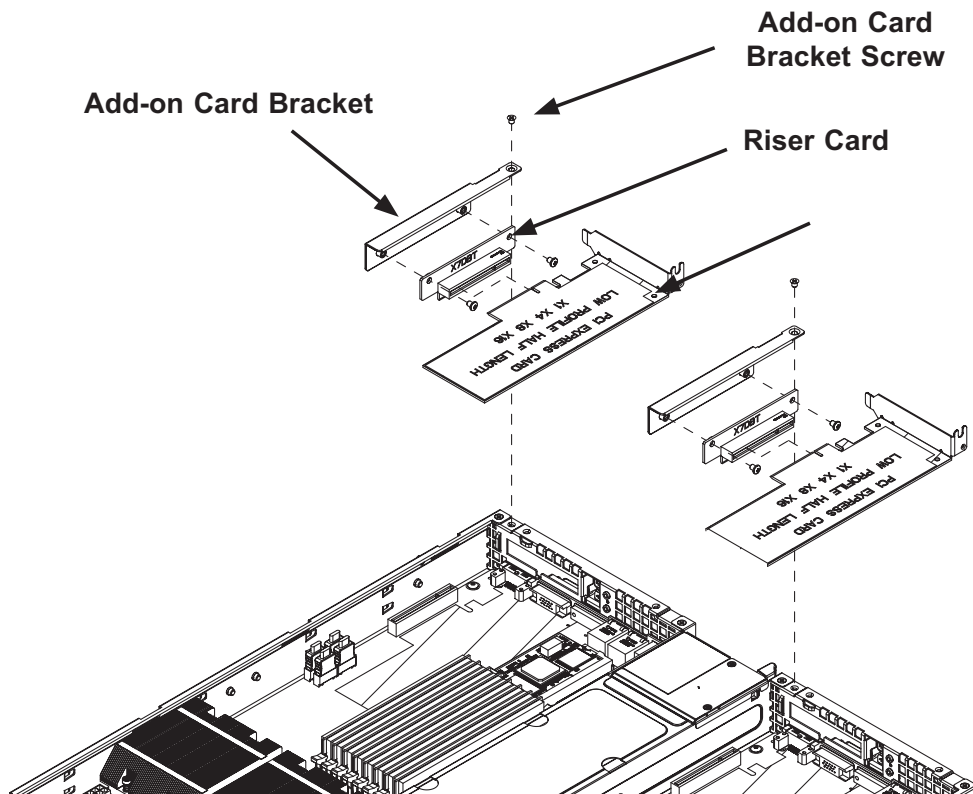

5-8 Serverboard Details

Figure 5-5. X7DCT-10G Layout

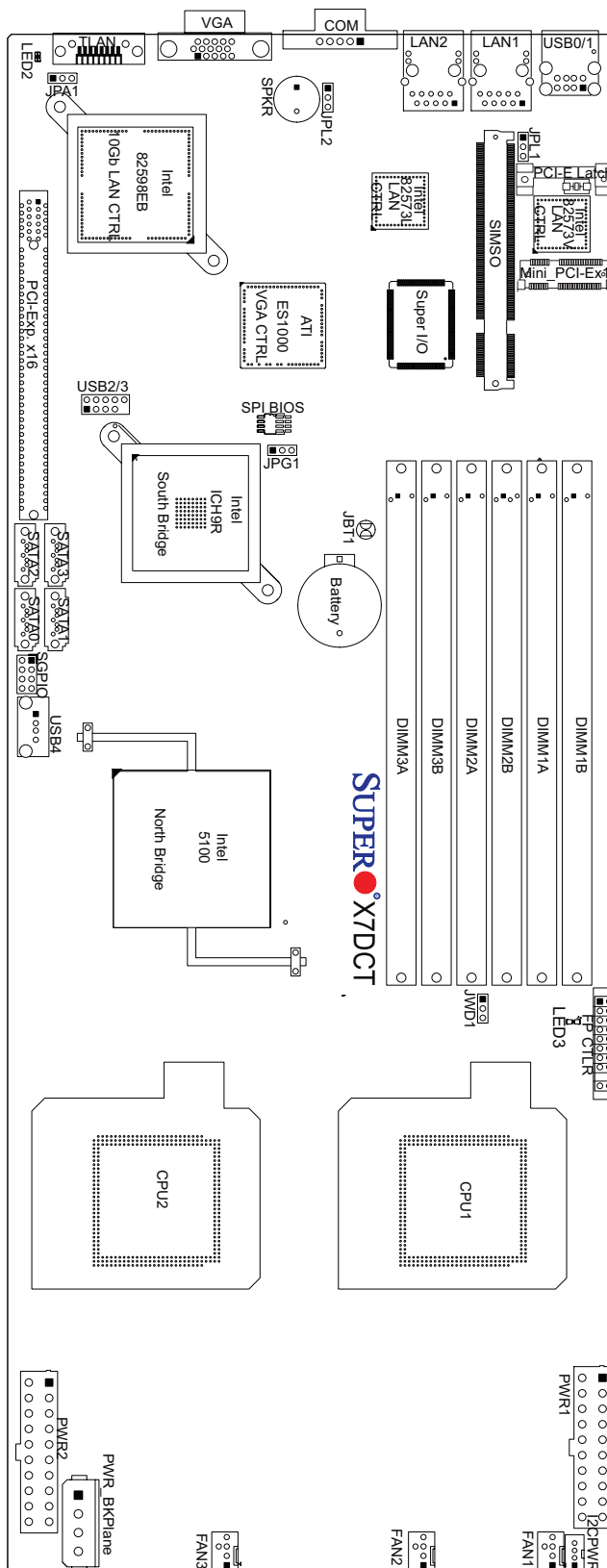

X7DCT/X7DCT-10G Quick Reference

Jumper	Description	Default Setting
JBT1	CMOS Clear	(See Section 5-10)
JPA1	10 Gb LAN Enable/Disable	Pins 1-2 (Enabled)
JPG1	VGA Enable/Disable	Pins 1-2 (Enabled)
JPL1/JPL2	LAN1/2 Enable/Disable	Pins 1-2 (Enabled)
JWD	Watch Dog	Pins 1-2 (Reset)

Connector	Description
COM	COM (Serial) Port
FAN 1-3	System Fan Headers
I ² C_PWR	I ² C Power Connector
JF1	Control Panel Header
LAN1/2	Gigabit Ethernet (RJ45) Ports
JF1	Front Panel Connector
JP10	4-pin Power Connector (for HDDs)
JWR1	20-pin ATX Power Connector
JWR2	20-pin ATX Power Connector
SATA0 ~ SATA3	SATA Ports 0 ~ 3
SGPIO	Serial General Purpose Input/Output Header
SIMSO	SIMSO (IPMI) Slot
TLAN	10 Gb LAN Port
USB0/1/4	Universal Serial Bus (USB) Ports
USB2/3	Universal Serial Bus (USB) Headers

LED	Description
LE2	10 Gb LAN Activity
LE3	Onboard Power

Jumpers not indicated are for test purposes only.

The 10 Gb LAN port is included on the X7DCT-10G only.

5-9 Connector Definitions

ATX Power Connector

The main ATX power supply connectors on the X7DCT/X7DCT-10G meets the SSI (Superset ATX) 20-pin specification. Refer to the table on the right for the pin definitions. Only one of the two ATX power connectors from each serverboard should be connected to the power supply.

ATX Power 20-pin Connector Pin Definitions (ATX Power 1/2)			
Pin#	Definition	Pin #	Definition
11	PS On	1	Ground
12	5VSB	2	Ground
13	Ground	3	Ground
14	Ground	4	Ground
15	Ground	5	Ground
16	NC2	6	NC1
17	12V	7	12V
18	12V	8	12V
19	12V	9	12V
20	12V	10	12V

Auxiliary Power Connector

A 4-pin 12V auxiliary power connector is included to provide power to hard drive disks. See the table on the right for pin definitions.

Auxiliary Power Pin Definitions (JP1)	
Pin#	Definition
1	+12V
2	Ground
3	Ground
4	+5V

PW_ON Connector

The PW_ON connector is on pins 1 and 2 of JF1. This header should be connected to the chassis power button. See the table on the right for pin definitions.

Power Button Pin Definitions (JF1)	
Pin#	Definition
1	PW_ON
2	Ground

Reset Connector

The reset connector is located on pins 3 and 4 of JF1 and attaches to the reset switch on the computer chassis. See the table on the right for pin definitions.

Reset Button Pin Definitions (JF1)	
Pin#	Definition
3	Reset
4	Ground

Overheat LED (OH)

Connect an LED to the OH connection on pins 7 and 8 of JF1 to provide advanced warning of chassis overheating. Refer to the table on the right for pin definitions.

OH/Fan Fail LED Pin Definitions (JF1)	
Pin#	Definition
7	Vcc
8	Ground

NIC2 (LAN2) LED

The LED connections for LAN2 are on pins 9 and 10 of JF1. Attach LAN LED cables to display network activity. See the table on the right for pin definitions.

NIC2 LED Pin Definitions (JF1)	
Pin#	Definition
9	Vcc
10	Ground

NIC1 (LAN1) LED

The LED connections for LAN1 are on pins 11 and 12 of JF1. Attach LAN LED cables to display network activity. See the table on the right for pin definitions.

NIC1 LED Pin Definitions (JF1)	
Pin#	Definition
11	Vcc
12	Ground

HDD LED

The HDD LED connection is located on pins 13 and 14 of JF1. Attach the hard drive LED cable here to display disk activity (for any hard drives on the system, including Serial ATA and IDE). See the table on the right for pin definitions.

HDD LED Pin Definitions (JF1)	
Pin#	Definition
13	Vcc
14	HD Active

Power On LED

The Power On LED connector is located on pins 15 and 16 of JF1. This connection is used to provide LED indication of power being supplied to the system. See the table on the right for pin definitions.

Power LED Pin Definitions (JF1)	
Pin#	Definition
15	5V Stby
16	Control

NMI Button

The non-maskable interrupt button header is located on pins 19 and 20 of JF1. Refer to the table on the right for pin definitions.

NMI Button Pin Definitions (JF1)	
Pin#	Definition
19	Control
20	Ground

Fan Headers

The X7DCT/X7DCT-10G has three 4-pin fan headers. See the table on the right for pin definitions.

Note: The onboard fan speed is controlled by the CPU die temperature.

Fan Header Pin Definitions (FAN1-3)	
Pin#	Definition
1	Ground (Black)
2	+12V (Red)
3	Tachometer
4	PWM Control

Universal Serial Bus (USB)

There are two Universal Serial Bus ports located on the I/O panel, two USB headers located on the serverboard and a third USB port (USB4) located onboard near the SGPIO header. The headers, labeled USB2 and USB3, can be used to provide front side USB access (cables not included). See the tables on the right for pin definitions.

USB Ports Pin Definitions (USB0/1/4)	
Pin#	Definition
1	+5V
2	PO-
3	PO+
4	Ground
5	N/A

USB Headers Pin Definitions (USB2/3)			
USB2		USB3	
Pin #	Definition	Pin #	Definition
1	+5V	1	+5V
2	PO-	2	PO-
3	PO+	3	PO+
4	Ground	4	Ground
5	Key	5	No connection

Serial Ports

One serial port is included on the serverboard. The COM port is located beside the VGA port. See the table on the right for pin definitions.

Serial Port Pin Definitions (COM)			
Pin #	Definition	Pin #	Definition
1	DCD	6	DSR
2	RXD	7	RTS
3	TXD	8	CTS
4	DTR	9	RI
5	Ground	10	NC

Note: NC indicates no connection.

SGPIO Header

An SGPIO (Serial General Purpose Input/Output) header is included on the serverboard. This header is used to communicate with the System Monitoring chip on the backplane to monitor SATA activity. See the table on the right for pin definitions.

SGPIO Header Pin Definitions (SGPIO)			
Pin#	Definition	Pin	Definition
1	NC	2	*NC
3	Ground	4	DATA Out
5	Load	6	Ground
7	Clock	8	*NC

Note: NC indicates no connection.

I²C Power Connector

This header is for I²C, which may be used to monitor the status of the power supply, fan and system temperature. See the table on the right for pin definitions.

I ² C Power Connector Pin Definitions (I ² C_PWR)	
Pin#	Definition
1	Clock
2	Data
3	Power Fail
4	Ground
5	+3.3V

5-10 Jumper Settings

To modify the operation of the serverboard, jumpers can be used to choose between optional settings. Jumpers create shorts between two pins to change the function of the connector. Pin 1 is identified with a square solder pad on the printed circuit board. See the serverboard layout pages for jumper locations.

Note: On a two-pin jumper, "Closed" means the jumper is on both pins and "Open" means the jumper is either on one pin or completely removed.

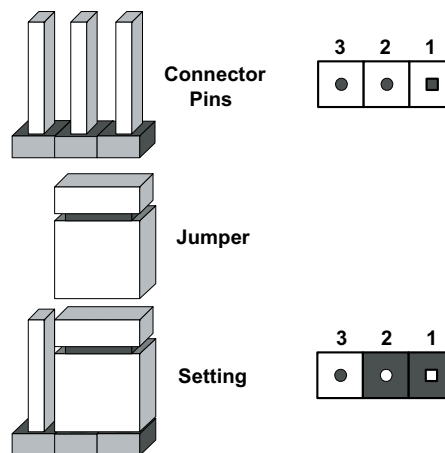

CMOS Clear

JBT1 is used to clear CMOS (which will also clear any passwords). Instead of pins, this jumper consists of contact pads to prevent accidentally clearing the contents of CMOS.

To Clear CMOS

1. First power down the system and unplug the power cord(s).
2. With the power disconnected, short the CMOS pads with a metal object such as a small screwdriver.
3. Remove the screwdriver (or shorting device).
4. Reconnect the power cord(s) and power on the system.

Note: Do not use the PW_ON connector to clear CMOS.

VGA Enable/Disable

JPG1 allows you to enable or disable the VGA port. The default position is on pins 1 and 2 to enable VGA. See the table on the right for jumper settings.

VGA Enable/Disable Jumper Settings (JPG1)	
Jumper Setting	Definition
Pins 1-2	Enabled
Pins 2-3	Disabled

LAN1/LAN2 Enable/Disable

Change the setting of jumper JPL1 to enable or disable the LAN1 port and JPL2 to enable or disable the LAN2 port on the serverboard. See the table on the right for jumper settings. The default setting is enabled.

LAN1/2 Enable/Disable Jumper Settings (JPL1/2)	
Jumper Setting	Definition
Pins 1-2	Enabled
Pins 2-3	Disabled

10 Gb LAN Enable/Disable

JPA1 allows you to enable or disable the 10 Gb LAN port, which is included on the X7DCT-10G (1025TC-10G) only. See the table on the right for jumper settings.

10 Gb LAN Enable/Disable Jumper Settings (JPA1)	
Jumper Setting	Definition
Pins 1-2	Enabled
Pins 2-3	Disabled

Watch Dog Enable/Disable

JWD enables the Watch Dog function, a system monitor that takes action when a software application freezes the system. Jumping pins 1-2 will have WD reboot the system if a program freezes. Jumping pins 2-3 will generate a non-maskable interrupt for the program that has frozen. See the table on the right for jumper settings. Watch Dog must also be enabled in BIOS.

Watch Dog Jumper Settings (JWD)	
Jumper Setting	Definition
Pins 1-2	Reset
Pins 2-3	NMI
Open	Disabled

Note: when Watch Dog is enabled, the user must write their own application software to disable the Watch Dog Timer.

5-11 Onboard Indicators

LAN1/LAN2 LEDs

The Ethernet ports (located beside the VGA port) have two LEDs. On each Gb LAN port, one LED indicates activity when blinking while the other LED may be green, amber or off to indicate the speed of the connection. See the table on the right for the functions associated with the connection speed LED.

LAN LED (Connection Speed Indicator)	
LED Color	Definition
Off	No connection or 10 MHz
Green	100 MHz
Amber	1 GHz

10 Gb LAN LED Indicator (LED2)

A LED indicator for the 10 Gb LAN port (LED2) is located near this port. This LED shows the status of the 10 Gb LAN port. Refer to the table on the right for indications.

10 Gb LAN LED (LED2)		
Color	Status	Definition
Green	Blinking	10 Gb LAN Active
Green	Solid	10 Gb LAN Connected
Yellow	Blinking	Gb LAN Active
Yellow	Solid	Gb LAN Connected

Onboard Power LED (LED3)

There is an Onboard Power LED (LE3) located near JF1. When the green light is on or flashing, the power is connected. Unplug the power cable before removing and changing any components. See the table on the right for indications.

Onboard Power LED Indicator (LED3)	
LED Color	Definition
Green (Solid)	Power On, System On
Green (flashing quickly)	ACPI S1 State
Green (flashing slowly)	ACPI S3 (STR) State
Off	Power: Off, power cable: not connected

5-12 Installing Additional Drivers

After you've installed the Windows Operating System, a screen as shown below will appear. You are ready to install software programs and drivers that have not yet been installed. To install these software programs and drivers, click the icons to the right of these items.

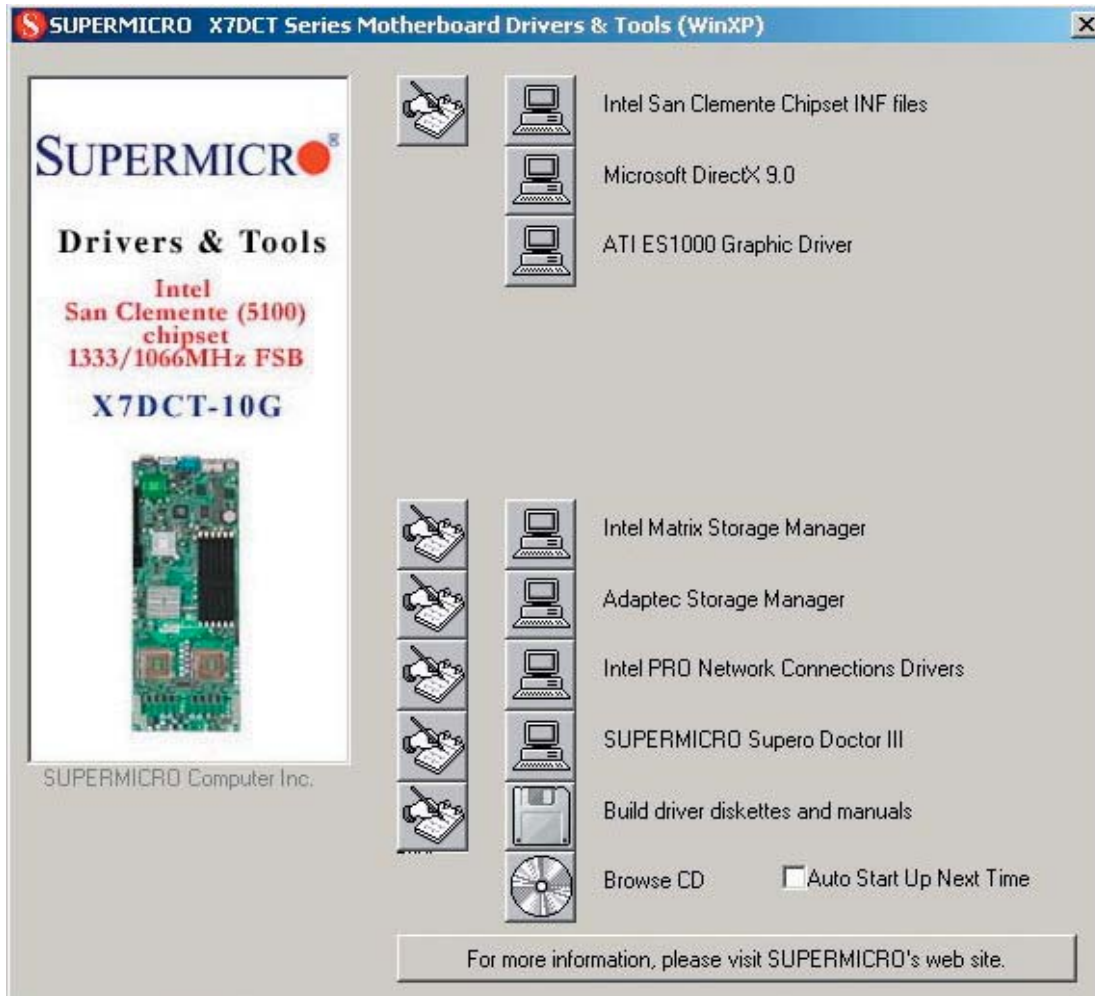

Driver/Tool Installation Display Screen

Note: Click the icons showing a hand writing on the paper to view the readme files for each item. Click a computer icon to the right of an item (from top to the bottom) one at a time. **After installing each item, you must re-boot the system before proceeding with the next item on the list.** The bottom icon with a CD on it allows you to view the entire contents of the CD.

5-13 Configuring Supero Doctor III

The Supero Doctor III program is a Web-base management tool that supports remote management capability. It includes Remote and Local Management tools. The local management is called the SD III Client. The Supero Doctor III program included on the CDROM that came with your motherboard allows you to monitor the environment and operations of your system. Supero Doctor III displays crucial system information such as CPU temperature, system voltages and fan status. See the Figure below for a display of the Supero Doctor III interface.

Notes: The default User Name and the Password are ADMIN.

In the Windows OS environment, the Supero Doctor III settings take precedence over the BIOS settings. When first installed, Supero Doctor III adopts the temperature threshold settings previously set in the BIOS. Any subsequent changes to these thresholds must be made within Supero Doctor, since the SD III settings override the BIOS settings. For the Windows OS to adopt the BIOS temperature threshold settings, please change the SDIII settings to be the same as those set in the BIOS.

Supero Doctor III Interface Display Screen-I (Health Information)





Note: SD III Software Revision 1.0 can be downloaded from our Web site at: ftp://ftp.supermicro.com/utility/Supero_Doctor_III/. You can also download SDIII User's Guide at: <http://www.supermicro.com/PRODUCT/Manuals/SDIII/UserGuide.pdf>. For Linux, we will still recommend that you use Supero Doctor II.

Chapter 6

Advanced Chassis Setup

This chapter covers the steps required to install components and perform maintenance on the SC809T-780B chassis. For component installation, follow the steps in the order given to eliminate the most common problems encountered. If some steps are unnecessary, skip ahead to the step that follows. The only tool you will need to install components and perform maintenance is a Philips screwdriver.

6-1 Static-Sensitive Devices

Electrostatic Discharge (ESD) can damage electronic components. To prevent damage to any printed circuit boards (PCBs), it is important to handle them very carefully. The following measures are generally sufficient to protect your equipment from ESD discharge.

Precautions

- Use a grounded wrist strap designed to prevent static discharge.
- Touch a grounded metal object before removing any board from its antistatic bag.
- Handle a board by its edges only; do not touch its components, peripheral chips, memory modules or gold contacts.
- When handling chips or modules, avoid touching their pins.
- Put the serverboard, add-on cards and peripherals back into their antistatic bags when not in use.
- For grounding purposes, make sure your computer chassis provides excellent conductivity between the power supply, the case, the mounting fasteners and the serverboard.

Unpacking

The serverboard is shipped in antistatic packaging to avoid static damage. When unpacking the board, make sure the person handling it is static protected.

Figure 6-1. Chassis Front View

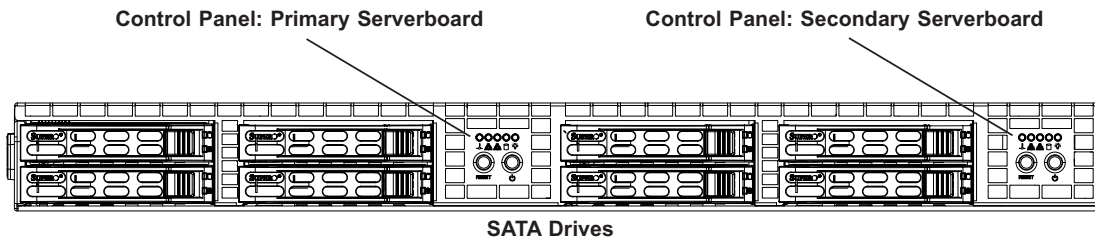
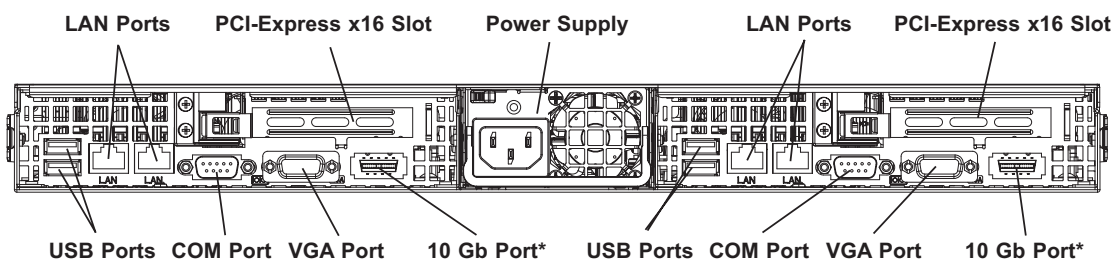

Figure 6-2. Chassis Rear View



*The 10 Gb ports are included on the 1025TC-10G only.

6-2 Control Panel

Each control panel on the front of the chassis must be connected to the JF1 connector on its associated serverboard to provide you with system control buttons and status indicators. (When viewed from the front of the chassis, the serverboard on the left is referred to as the primary serverboard and the serverboard on the right as the secondary.)

These wires have been bundled together in a ribbon cable to simplify the connection. Connect the cable from JF1 on the serverboard to the control panel PCB (printed circuit board). Make sure the red wire plugs into pin 1 on both connectors. Pull all excess cabling out of the airflow path. The LEDs inform you of system status for the serverboard it is connected to. See Chapter 3 for details on the LEDs and the control panel buttons. Details on JF1 can be found in Chapter 5.

6-3 System Fans

Each serverboard has its own set of three 4-cm high-performance PWM fans (for a total of six in the chassis) to provide the cooling for the 1025TC-T/1025TC-10G. Fan speed may be controlled by a setting in BIOS (see Chapter 7).

System Fan Failure

If a fan fails, the remaining fans will ramp up to full speed and the overheat/fan fail LED on the control panel will blink on and off. Replace any failed fan at your earliest convenience with the same type and model (the system can continue to run with a failed fan). Remove the top chassis cover while the system is still running to determine which of the fans has failed. The system fans are hot-swappable. There is no need to power down the system when switching fans.

Changing a System Fan (Figure 6-3)

1. If necessary, open the chassis while the power is running to determine which fan has failed. (Never run the server for an extended period of time with the chassis open.)
2. Remove the failed fan's power cord from the serverboard.
3. Lift the fan housing up and out of the chassis.
4. Gently push the fan upwards from underneath the fan housing to remove it.
5. Place the new fan into the vacant space in the housing while making sure the arrows on the top of the fan (indicating air direction) point in the same direction as the arrows on the other fans. Make sure that all four of the fan's rubber feet are in place.
6. Replace the fan housing back into the chassis.
7. Reconnect the wiring.
8. Confirm that the fan is working properly before replacing the chassis cover.

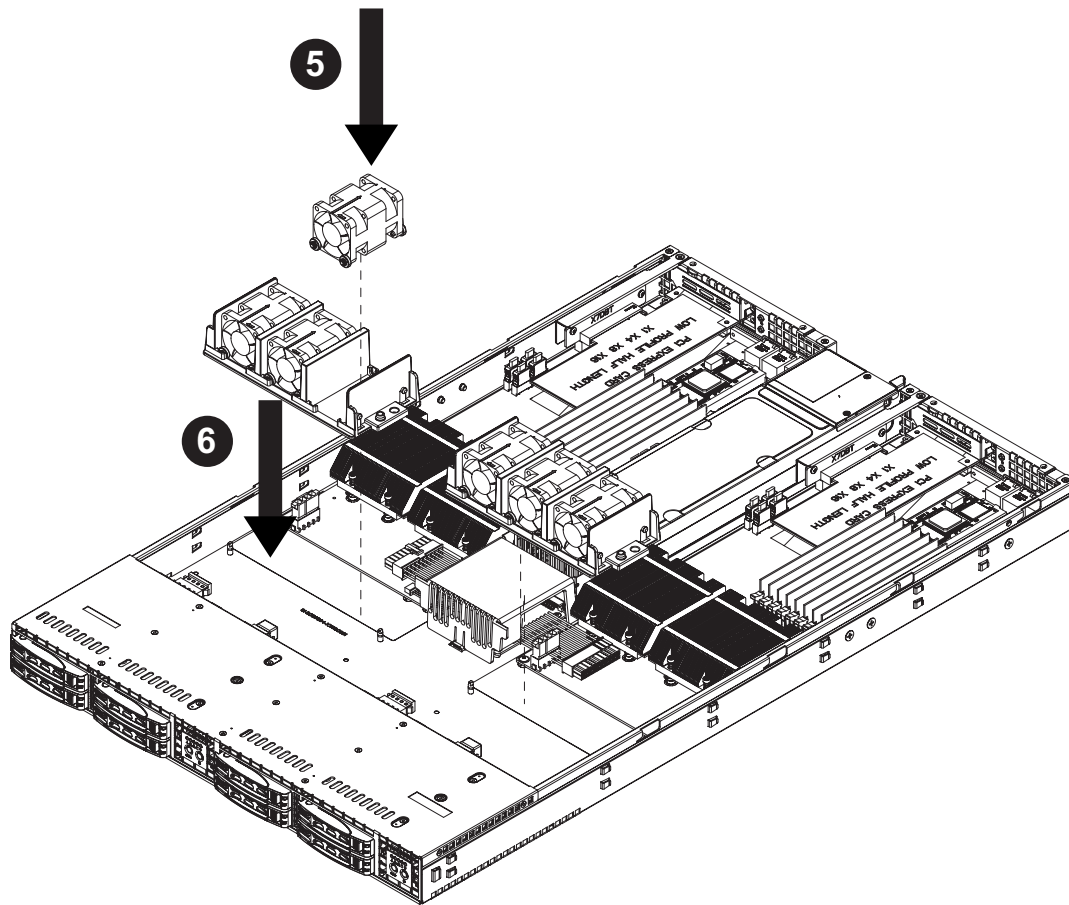

Figure 6-3: Replacing a System Fan

6-4 Air Shrouds

Air shrouds concentrate airflow to maximize fan efficiency. The SC809 chassis air shroud does not require screws to set up. Two identical air shrouds are needed in the system, one for each node.

Installing the Air Shrouds (Figure 6-4)

1. Confirm that all six fans are in place and working properly
2. Place the first air shroud into the chassis. The air shroud sits behind the system fans. Each air shroud covers three fans.
3. Install the second air shroud in the same manner as the first.

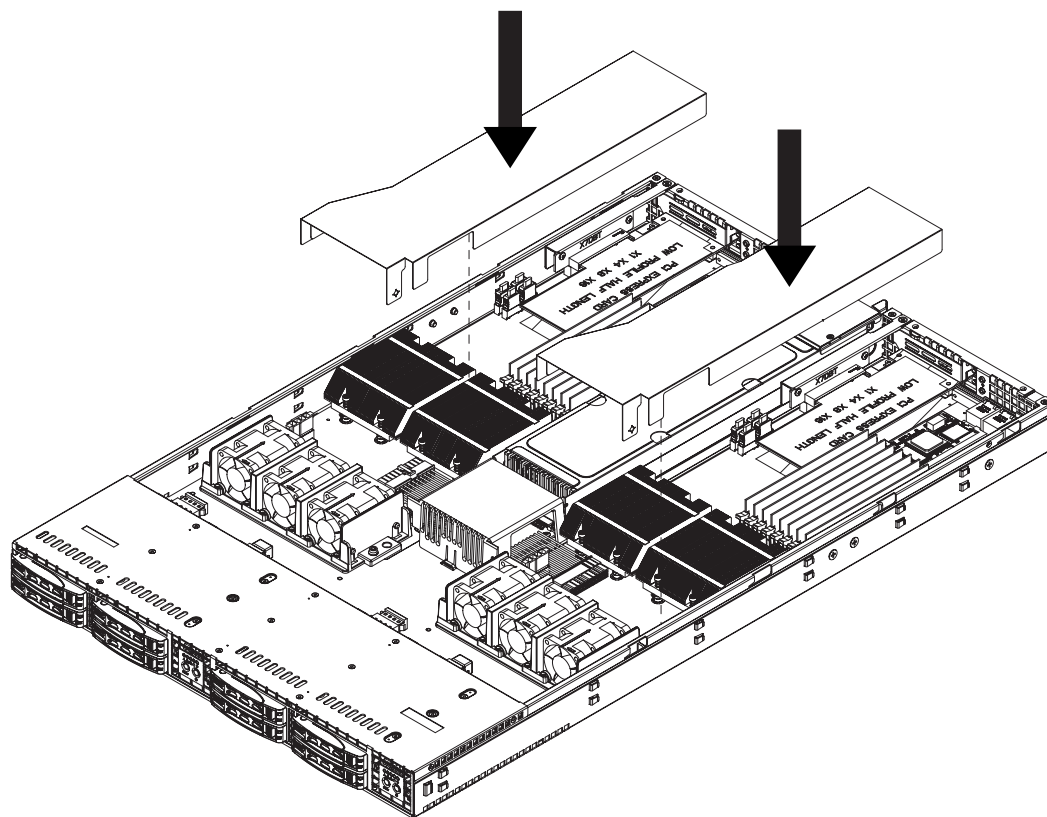

Figure 6-4: Installing the Air Shrouds

6-5 Drive Bay Installation/Removal

Accessing the Drive Bays

SATA Drives: Because of their hotswap capability, you do not need to access the inside of the chassis or power down the system to install or replace SATA drives. Proceed to the next step for instructions. **Note:** The operating system you use must have RAID support to enable the hot-swap capability of the SATA drives.



Use caution when working around the SATA backplane. Do not touch the backplane with any metal objects and make sure no cables touch the backplane. Also, regardless of how many SATA drives are installed, all eight drive carriers must remain in the chassis to maintain proper airflow.

SATA Drive Installation

The SATA drives are mounted in drive carriers to simplify their installation and removal from the chassis. These carriers also help promote proper airflow for the system. For this reason, even empty carriers without drives installed must remain in the chassis.

Mounting a SATA Drive in a Carrier (Figure 6-5)

1. Insert a drive into the carrier with the PCB side facing down and the connector end toward the rear of the carrier.
2. Align the drive in the carrier so that the screw holes of both line up. Note that there are holes in the carrier marked "SATA" to aid in correct installation.
3. Secure the drive to the carrier with four screws as illustrated below.
4. Insert the drive carrier into its bay, keeping the carrier oriented so that the hard drive is on the top of the carrier and the release button is on the right side. When the carrier reaches the rear of the bay, the release handle will retract.
5. Push the handle in until it clicks into its locked position.

Figure 6-5. Mounting a Drive in a Carrier

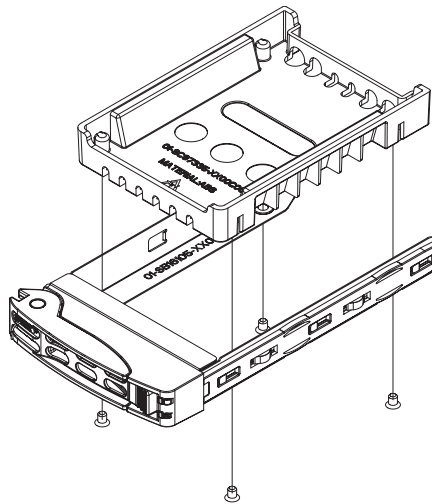

Installing/Removing Hot-swap SATA Drives (Figure 6-6)

1. To remove a carrier, push the release button located beside the drive LEDs.
2. Swing the handle fully out and use it to pull the unit straight out (see Figure 6-6).

Figure 6-6. Removing a Drive

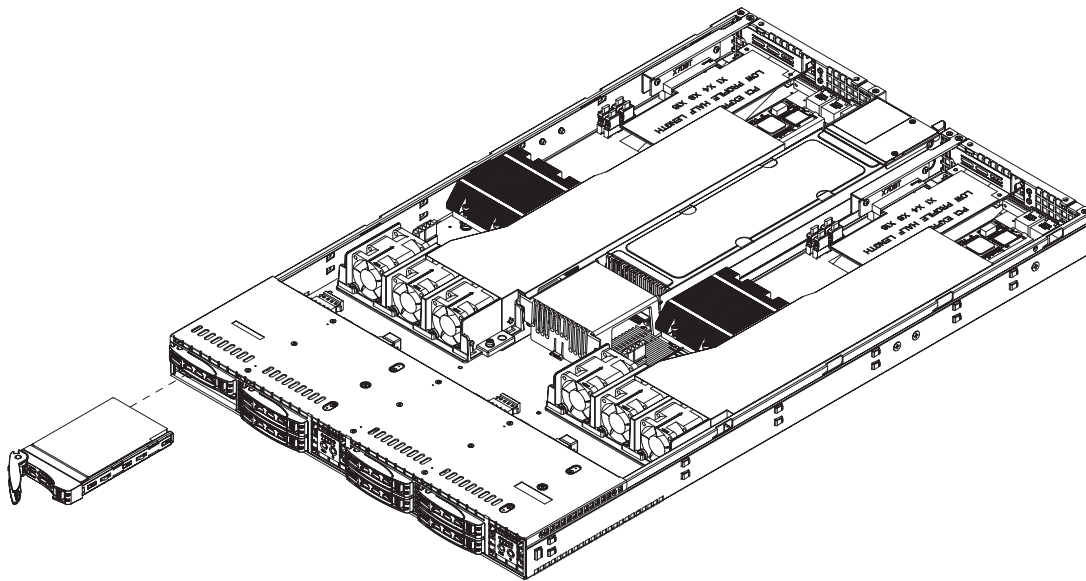

6-6 Power Supply

The SuperServer 1025TC-T/1025TC-10G has a single 780 watt power supply. This power supply has the capability of operating at 100 - 240 input volts.

Note: The power supply has an output of 700W with a 100-140V input and 780W with a 180-240V input.

Power Supply Failure

If the power supply unit fails, the system will shut down and you will need to replace the power supply unit. Replacement units can be ordered directly from Supermicro (PWS-781-1S - see contact information in Chapter 1).

Replacing the Power Supply

Depress both main power buttons on the front of the chassis and then unplug the AC power cord to completely remove power from the system before removing the power supply.

Installing a New Power Supply (Figure 6-7)

1. Replace the failed unit with the exact same power supply model from Supermicro.
2. First power down both system nodes with the main power buttons then unplug the power cord.

3. Push the release tab (on the back of the power supply) as illustrated.
4. Pull the power supply out using the handle provided.
5. Push the new power supply module into the power bay until it clicks into place.
6. Plug the AC power cord back into the module and power up the server.

Figure 6-7. Removing the Power Supply
Release Tab

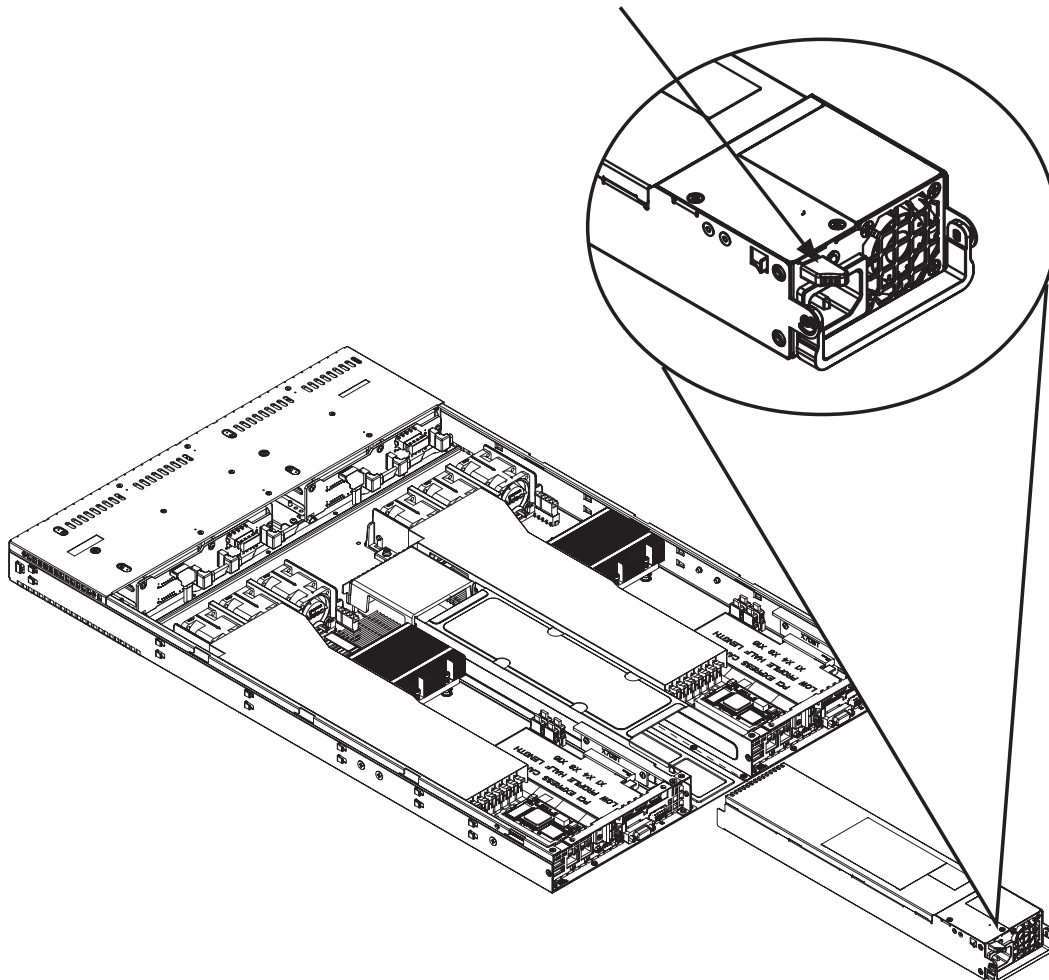

Chapter 7

BIOS

7-1 Introduction

This chapter describes the Phoenix BIOS™ Setup utility for the X7DCT/X7DCT-10G. The Phoenix ROM BIOS is stored in a flash chip and can be easily upgraded using a floppy disk-based program.

Note: Due to periodic changes to the BIOS, some settings may have been added or deleted and might not yet be recorded in this manual. Please refer to the Manual Download area of the Super Micro web site <<http://www.supermicro.com>> for any changes to the BIOS that may not be reflected in this manual.

System BIOS

The BIOS is the Basic Input Output System used in all IBM® PC, XT™, AT®, and PS/2® compatible computers. The Phoenix BIOS stores the system parameters, types of disk drives, video displays, etc. in the CMOS. The CMOS memory requires very little electrical power. When the computer is turned off, a backup battery provides power to the CMOS Logic, enabling it to retain system parameters. Each time the computer is powered on, the computer is configured with the values stored in the CMOS Logic by the system BIOS, which gains control at boot up.

How To Change the Configuration Data

The CMOS information that determines the system parameters may be changed by entering the BIOS Setup utility. This Setup utility can be accessed by pressing the <Delete> key at the appropriate time during system boot. (See below.)

Starting the Setup Utility

Normally, the only visible POST (Power On Self Test) routine is the memory test. As the memory is being tested, press the <Delete> key to enter the main menu of the BIOS Setup utility. From the main menu, you can access the other setup screens, such as the Security and Power menus. Beginning with Section 7-3, detailed descriptions are given for each parameter setting in the Setup utility.



Warning: Do not shut down or reset the system while updating BIOS to prevent possible boot failure.

7-2 Running Setup

Default settings are in bold text unless otherwise noted.

The BIOS setup options described in this section are selected by choosing the appropriate text from the main BIOS Setup screen. All displayed text is described in this section, although the screen display is often all you need to understand how to set the options (see the next page).

When you first power on the computer, the Phoenix BIOS™ is immediately activated.

While the BIOS is in control, the Setup program can be activated in one of two ways:

1. By pressing <Delete> immediately after turning the system on, or
2. When the message shown below appears briefly at the bottom of the screen during the POST (Power On Self-Test), press the <Delete> key to activate the main Setup menu:

Press the <Delete> key to enter Setup

7-3 Main BIOS Setup

All main Setup options are described in this section. The main BIOS Setup screen is displayed below.

Use the Up/Down arrow keys to move among the different settings in each menu. Use the Left/Right arrow keys to change the options for each setting.

Press the <Esc> key to exit the CMOS Setup Menu. The next section describes in detail how to navigate through the menus.

Items that use submenus are indicated with the ► icon. With the item highlighted, press the <Enter> key to access the submenu.

Main BIOS Setup Menu

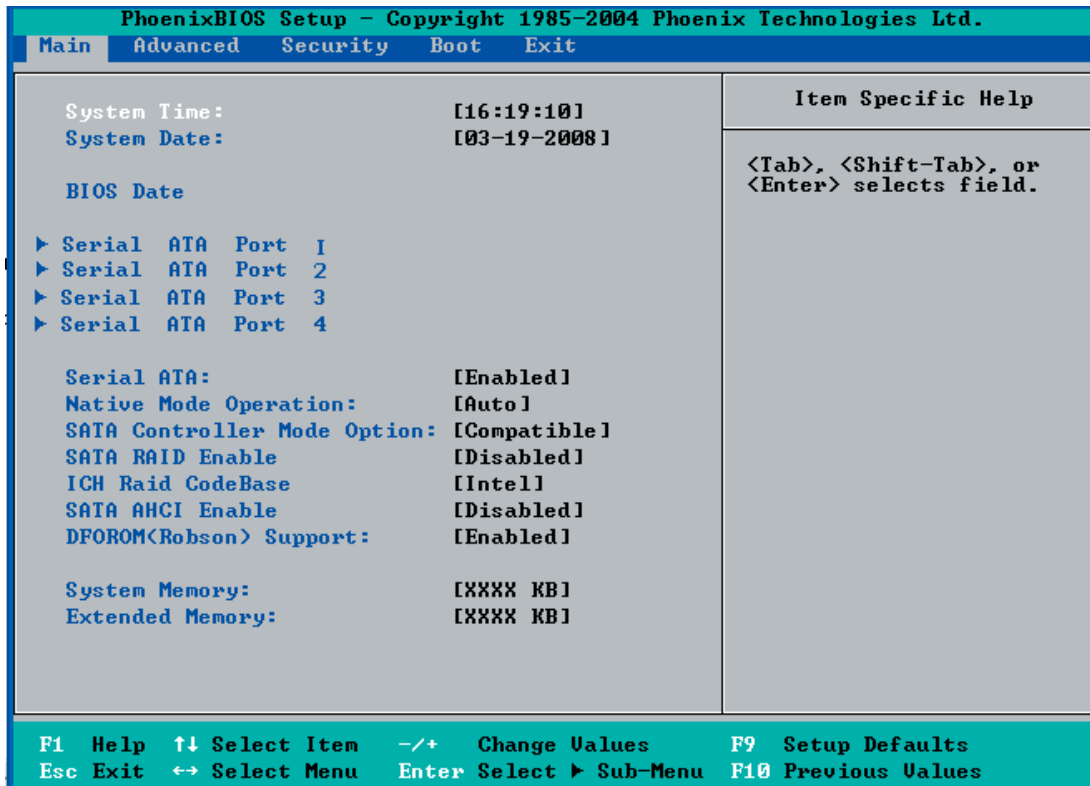

Main Setup Features

System Time

To set the system date and time, key in the correct information in the appropriate fields. Then press the <Enter> key to save the data.

System Date

Using the arrow keys, highlight the month, day and year fields, and enter the correct data. Press the <Enter> key to save the data.

BIOS Date

This field displays the date when this version of BIOS was built.

Legacy Diskette A

This setting allows the user to set the type of floppy disk drive installed as diskette A. The options are Disabled, 360Kb 5.25 in, 1.2MB 5.25 in, 720Kb 3.5 in, **1.44/1.25MB**, 3.5 in and 2.88MB 3.5 in.

► SATA Port1, SATA Port2, SATA Port3 and SATA Port4

These settings allow the user to set the parameters of SATA Port, SATA Port, SATA Port3 and SATA Port4. Hit <Enter> to activate the following sub-menu screen for detailed options of these items. Set the correct configurations accordingly. The items included in the sub-menu are:

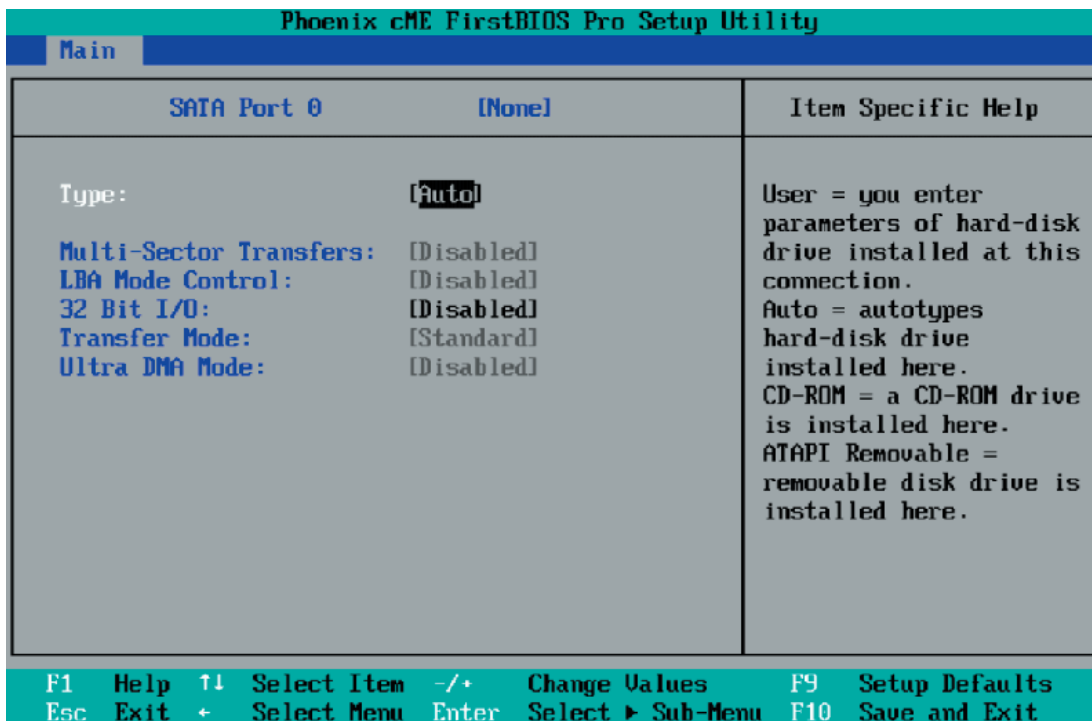

Type

This option allows the user to select the type of IDE hard drive. The option **Auto** will allow the BIOS to automatically configure the parameters of the HDD installed at the connection. Enter a number between 1 to 39 to select a predetermined HDD type. Select **User** to allow the user to enter the parameters of the HDD installed. Select **CDROM** if a CDROM drive is installed. Select **ATAPI** if a removable disk drive is installed.

LBA Format

The following items will be displayed by the BIOS:

Total Sectors

This item displays the number of total sectors available in the LBA Format.

Maximum Capacity

This item displays the maximum capacity in the LBA Format.

Multi-Sector Transfers

This item allows the user to specify the number of sectors per block to be used in multi-sector transfer. The options are **Disabled**, 4 Sectors, 8 Sectors and 16 Sectors.

LBA Mode Control

This item determines whether the Phoenix BIOS will access the IDE Channel 0 Master Device via the LBA mode. The options are Enabled and **Disabled**.

32 Bit I/O

This option allows the user to enable or disable the function of 32-bit data transfer. The options are Enabled and **Disabled**.

Transfer Mode

This option allows the user to set the transfer mode. The options are **Standard**, Fast PIO1, Fast PIO2, Fast PIO3, Fast PIO4, FPIO3/DMA1 and FPIO4/DMA2.

Ultra DMA Mode

This option allows the user to select Ultra DMA Mode. The options are **Disabled**, Mode 0, Mode 1, Mode 2, Mode 3, Mode 4 and Mode 5.

Serial ATA

This setting allows the user to enable or disable the function of the Serial ATA. The options are Disabled and **Enabled**.

Native Mode Operation

Select the native mode for ATA. The options are Parallel ATA, Serial ATA, Both and **Auto**.

SATA Controller Mode

Select **Compatible** to allow the SATA and PATA drives to be automatically detected and be placed in the Legacy Mode by the BIOS. Select Enhanced to allow the SATA and PATA drives to be to be automatically detected and be placed in the Native IDE Mode. (**Note: The Enhanced mode is supported by Windows 2000 OS or later versions.**)

When the SATA Controller Mode is set to "Enhanced", the following items will display:

Serial ATA (SATA) RAID Enable

Select Enable to enable Serial ATA RAID Functions. (For a Windows OS environment, use the RAID driver if this feature is set to Enabled. If this item is set to

Disabled, the item-SATA AHCI Enable will be available.) The options are Enabled and **Disabled**.

ICH RAID Code Base

Select to enable which SATA RAID firmware to configure. The options are **Intel** and Adaptec.

DFOROM (Roboson) Support

Select Enabled to enable DFOROM (Roboson) support. The options are Enabled and Disabled.

SATA AHCI

Select Enable to enable the function of Serial ATA Advanced Host Interface. (Use caution when enabling this function. This feature is for advanced programmers only.) The options are Enabled and **Disabled**.

System Memory

This display informs you how much system memory is recognized as being present in the system.

Extended Memory

This display informs you how much extended memory is recognized as being present in the system.

7-4 Advanced Setup

Choose Advanced from the Phoenix BIOS Setup Utility main menu with the arrow keys. You should see the following display. The items with a triangle beside them have sub menus that can be accessed by highlighting the item and pressing <Enter>.

► Boot Features

Access the submenu to make changes to the following settings.

QuickBoot Mode

If enabled, this feature will speed up the POST (Power On Self Test) routine by skipping certain tests after the computer is turned on. The settings are **Enabled** and Disabled. If Disabled, the POST routine will run at normal speed.

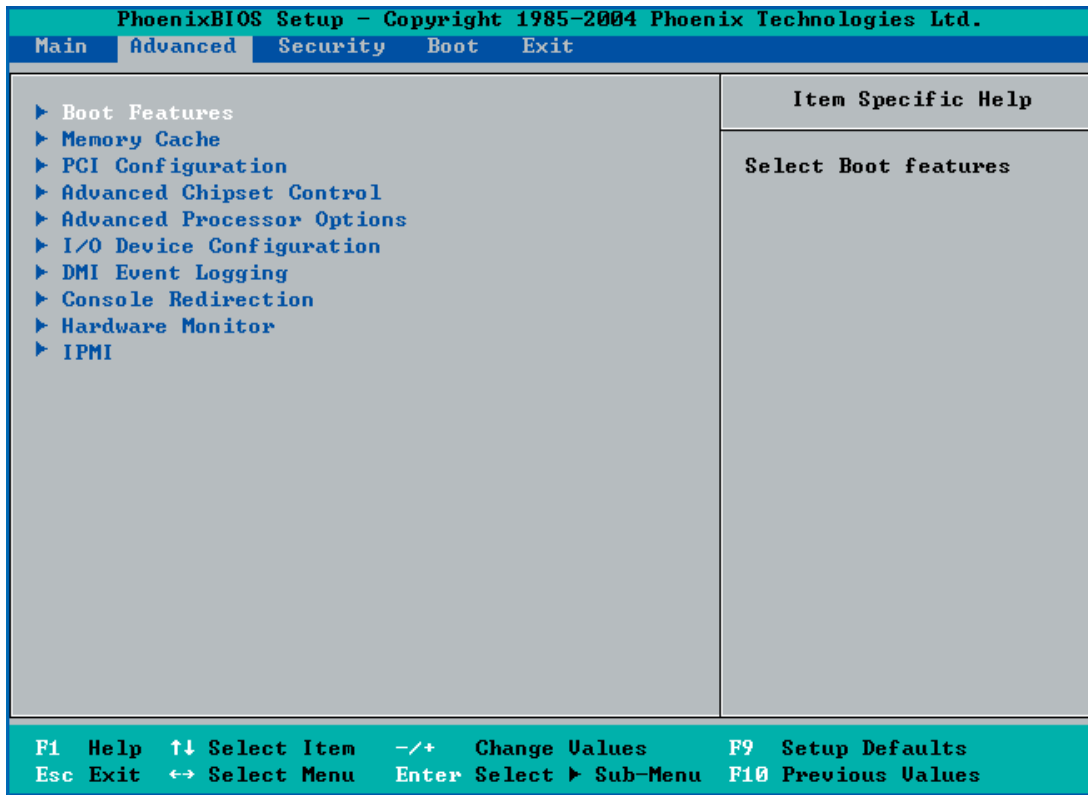

QuietBoot Mode

This setting allows you to **Enable** or Disable the graphic logo screen during boot-up.

POST Errors

Set to **Enabled** to display POST Error Messages if an error occurs during bootup. If set to Disabled, the system will continue to boot without displaying any error message even when a boot error occurs.

ACPI Mode

Use the setting to determine if you want to employ ACPI (Advanced Configuration and Power Interface) power management on your system. The options are **Yes** and No.

Power Button Behavior

If set to Instant-Off, the system will power off immediately as soon as the user hits the power button. If set to 4-sec., the system will power off when the user presses the power button for 4 seconds or longer. The options are **Instant-Off** and 4-sec override.

Resume On Modem Ring

Select On to “wake your system up” when an incoming call is received by your modem. The options are On and **Off**.

Power Loss Control

This setting allows you to choose how the system will react when power returns after an unexpected loss of power. The options are Stay Off, Power On, and **Last State**.

Watch Dog

If enabled, this option will automatically reset the system if the system is not active for more than 5 minutes. The options are Enabled and **Disabled**.

Summary Screen

This setting allows you to **Enable** or Disable the summary screen which displays the system configuration during bootup.

► Memory Cache

Cache System BIOS Area

This setting allows you to designate a reserve area in the system memory to be used as a System BIOS buffer into which BIOS can write (cache) data. Select **Write Protect** to enable this function, and this area will be reserved for BIOS ROM access only. Select Uncached to disable this function and make this area available for other devices.

Cache Video BIOS Area

This setting allows you to designate a reserve area in the system memory to be used as a Video BIOS buffer into which BIOS can write (cache) data. Select **Write Protect** to enable the function and this area will be reserved for Video BIOS ROM access only. Select Uncached to disable this function and make this area available for other devices.

Cache Base 0-512K

If enabled, this feature will allow the data stored in the base memory block 0-512K to be cached (written) into a buffer, a storage area in the Static DRAM (SDRAM) or to be written into the L1/L2 cache inside the CPU to speed up CPU operations. Select Uncached to disable this function. Select Write Through to allow data to be cached into the buffer and written into the system memory at the same time. Select Write Protect to prevent data from being written into the base memory area of Block 0-512K. Select Write Back to allow the CPU to write data back directly from the buffer without writing data to the System Memory for fast CPU data processing and operation. The options are Uncached, Write Through, Write Protect and **Write Back**.

Cache Base 512K-640K

If enabled, this feature will allow the data stored in the memory area 512K-640K to be cached (written) into a buffer, a storage area in the Static DRAM (SDRAM) or written into the L1/L2/L3 cache inside the CPU to speed up CPU operations. Select Uncached to disable this function. Select Write Through to allow data to be cached into the buffer and written into the system memory at the same time. Select Write Protect to prevent data from being written into the base memory area of Block 512-640K. Select Write Back to allow the CPU to write data back directly from the buffer without writing data to the System Memory for fast CPU data processing and operation. The options are Uncached, Write Through, Write Protect and **Write Back**.

Cache Extended Memory

If enabled, this feature will allow the data stored in the extended memory area to be cached (written) into a buffer, a storage area in the Static DRAM (SDRAM) or written into the L1/L2/L3 cache inside the CPU to speed up CPU operations. Select Uncached to disable this function. Select Write Through to allow data to be cached into the buffer and written into the system memory at the same time. Select Write Protect to prevent data from being written into the extended memory area above 1MB. Select Write Back to allow the CPU to write data back directly from the buffer without writing data to the System Memory for fast CPU data processing and operation. The options are Uncached, Write Through, Write Protect and **Write Back**.

Discrete MTRR Allocation

If enabled, MTRRs (Memory Type Range Registers) are configured as distinct separate units and cannot be overlapped. If enabled, the user can achieve better graphic effects when using a Linux graphic driver that requires the write-combining configuration with 4GB or more memory. The options are Enabled and **Disabled**.

► PCI Configuration

Access the submenu to make changes to the following settings for PCI devices.

Onboard GLAN-1/Onboard GLAN-2 OPROM Configure

Select Enabled to allow the system to boot from the GLAN1 connection, the GLAN2 connection or the 10 Gb LAN port. The options are **Disabled** and Enabled.

Default Primary Video Adapter

This feature allows the user to specify which video adapter to be used as the default primary video adapter. The options are Other and **Onboard Video**.

Reset Configuration Data

If set to Yes, this setting clears the Extended System Configuration Data (ESCD) area. The options are Yes and **No**.

► PCI-Exp. x16

Access the submenu for each of the settings above to make changes to the following:

Option ROM Scan

When enabled, this setting will initialize the device expansion ROM. The options are **Enabled** and Disabled.

Enable Master

This setting allows you to enable the selected device as the PCI bus master. The options are **Enabled** and Disabled.

Latency Timer

This setting allows you to set the clock rate for the Bus Master. A high-priority, high-throughput device may benefit from a greater clock rate. The options are **Default**, 0020h, 0040h, 0060h, 0080h, 00A0h, 00C0h, 00E0h and Other. For Unix, Novell and other Operating Systems, please select "Other". If a drive fails after the installation of a new software, you might want to change this setting and try again. Different OSes require different Bus Master clock rates.

Large Disk Access Mode

This setting determines how large hard drives are to be accessed. The options are **DOS** or Other (for Unix, Novelle NetWare and other operating systems).

► Advanced Chipset Control

Access the submenu to make changes to the following settings.



Warning: Take Caution when changing the Advanced settings. An incorrect setup, a very high DRAM frequency or an incorrect DRAM timing may cause the system become unstable. When this occurs, reset the setting to the default setting.

Clock Spectrum Feature

If Enabled, the BIOS will monitor the level of Electromagnetic Interference caused by the components and will attempt to decrease the interference whenever needed. The options are Enabled and **Disabled**.

Crystal Beach Features

This feature cooperates with the Intel I/O AT (Acceleration Technology) to accelerate the performance of TOE devices. (Note: A TOE device is a specialized, dedicated processor that is installed on an add-on card or a network card to handle some or all packet processing of this add-on card. For this motherboard, the TOE device is built inside the South Bridge chip.) The options are **Enabled** and Disabled.

SERR Signal Condition

This setting specifies the ECC Error conditions that an SERR# is to be asserted. The options are None, **Single Bit**, Multiple Bit and Both.

4GB PCI Hole Granularity

This feature allows you to select the granularity of PCI hole for PCI slots. If MTRRs are not enough, this option may be used to reduce MTRR occupation. The options are **256 MB**, 512 MB, 1GB and 2GB.

Channel 0 Rank Sparing/Channel 1 Rank Sparing

Select Enable to enable the function of memory sparing for Memory Bus Branch 0 or Branch 1. The options are Enabled and **Disabled**.

Enhanced x8 Detection

Select Enabled to enable Enhanced x8 DRAM UC Error Detection. The options are Disabled and **Enabled**.

Patrol Scrubbing

Scrubbing is a process that allows the North Bridge to correct correctable memory errors detected on a memory module, and send the correction to the requestor (the original source). When this item is set to Enabled, the North Bridge will read and write back one cache line every 16K cycles, if there is no delay caused by internal processing. By using this method, roughly 64 GB of memory behind the North Bridge will be scrubbed every day. The options are **Enabled** and Disabled.

Demand Scrubbing

Scrubbing is a process that allows the North Bridge to correct correctable memory errors found on a memory module. When the CPU or I/O issues a demand- read-command and the read data from memory turns out to be a correctable error, the error is corrected and sent to the requestor (the original source). Memory is updated as well. Select **Enabled** to use Demand Scrubbing for ECC memory correction.

Enable Multi-Media Timer

Select Yes to activate a set of timers that are alternative to the traditional 8254 timers for the OS use. The options are Yes and **No**.

USB Host Controller

Select Enabled to enable USB Host Controller 1. The options are **Enabled** and Disabled.

Legacy USB Support

This setting allows you to enable support for Legacy USB devices. The settings are **Enabled** and Disabled.

►Advanced Processor Options

Access the submenu to make changes to the following settings.

CPU Speed

This is a display that indicates the speed of the installed processor.

Frequency Ratio (Available if supported by the CPU)

The feature allows the user to set the internal frequency multiplier for the CPU. The options are **Default**, x12, x13, x14, x15, x16, x17 and x18.

Core-Multi-Processing (Available if supported by the CPU)

Set to Enabled to use a processor's Second Core and beyond. (Please refer to Intel's web site for more information.) The options are Disabled and **Enabled**.

Machine Checking (Available when supported by the CPU)

Set to Enabled to activate the function of Machine Checking and allow the CPU to detect and report hardware (machine) errors via a set of model-specific registers (MSRs). The options are Disabled and **Enabled**.

C1 Enhanced Mode (Available if supported by the CPU)

Set to Enabled to enable Enhanced Halt State to lower CPU voltage/frequency to prevent overheat. The options are Enabled and **Disabled**. Note: please refer to Intel's web site for detailed information.)

Execute Disable Bit (Available if supported by the CPU and the OS)

Set to **Enabled** to enable Execute Disable Bit and allow the processor to classify areas in memory where an application code can execute and where it cannot, and thus preventing a worm or a virus from inserting and creating a flood of codes to overwhelm the processor or damage the system during an attack. This feature is available when your OS and your CPU support the function of Execute Disable Bit. The options are Disabled and **Enabled**. **Note:** For more information regarding hardware/software support for this function, please refer to Intel's and Microsoft's web sites.

Adjacent Cache Line Prefetch (Available when supported by the CPU)

The CPU fetches the cache line for 64 bytes if this option is set to Disabled. The CPU fetches both cache lines for 128 bytes as comprised if Enabled. The options are **Disabled** and Enabled.

Hardware Prefetcher (Available when supported by the CPU)

Set to this option to enabled to enable the hardware components that are used inconjunction with software programs to prefetch data in order to shorten executioncycles and maximize data processing efficiency. The options are Disabled and **Enabled**.

Intel <R> Virtualization Technology (Available when supported by the CPU)

Select Enabled to use the feature of Virtualization Technology to allow one platform to run multiple operating systems and applications in independent partitions, creating multiple "virtual" systems in one physical computer. The options are Enabled and **Disabled**. Note: If there is any change to this setting, you will need to power off and restart the system for the change to take effect. Please refer to Intel's web site for detailed information.

Intel EIST Support (Available if supported by the CPU)

Select Enabled to use the Enhanced Intel SpeedStep Technology and allows the system to automatically adjust processor voltage and core frequency in an effort to reduce power consumption and heat dissipation. The options are Enabled and **Disabled**. Please refer to Intel's web site for detailed information.

►CPU Cache Control

Adjacent Cache Line Prefetch (Available when supported by the CPU)

The CPU fetches the cache line for 64 bytes if this option is set to Disabled. The CPU fetches both cache lines for 128 bytes as comprised if Enabled. The options are **Disabled** and Enabled.

IP Prefetch (Available when supported by the CPU)

Select Enabled to use CPU Cache Line IP Prefetch. The options are Disabled and **Enabled**.

Direct Cache Access (Available when supported by the CPU)

Set to Enable to route inbound network IO traffic directly into processor caches to reduce memory latency and improve network performance. The options are **Disabled** and Enabled.

►I/O Device Configuration

Access the submenu to make changes to the following settings.

Serial Port A

This setting allows you to assign control of serial port A. The options are **Enabled** (user defined), Disabled and Auto (BIOS or OS controlled).

Base I/O Address

This setting allows you to select the base I/O address for serial port A. The options are **3F8**, 2F8, 3E8 and 2E8.

Interrupt

This setting allows you to select the IRQ (interrupt request) for serial port A. The options are IRQ3 and **IRQ4**.

Serial Port B

This setting allows you to assign control of serial port B. The options are **Enabled** (user defined), Disabled, Auto (BIOS controlled) and OS Controlled.

Mode

This setting allows you to set the type of device that will be connected to serial port B. The options are **Normal** and IR (for an infrared device).

Base I/O Address

This setting allows you to select the base I/O address for serial port B. The options are 3F8, **2F8**, 3E8 and 2E8.

Interrupt

This setting allows you to select the IRQ (interrupt request) for serial port B. The options are **IRQ3** and IRQ4.

► DMI Event Logging

Access the submenu to make changes to the following settings.

Event Log Validity

This is a display to inform you of the event log validity. It is not a setting.

Event Log Capacity

This is a display to inform you of the event log capacity. It is not a setting.

View DMI Event Log

Highlight this item and press <Enter> to view the contents of the event log.

Event Logging

This setting allows you to **Enable** or Disable event logging.

ECC Event Logging

This setting allows you to **Enable** or Disable ECC event logging.

Mark DMI Events as Read

Highlight this item and press <Enter> to mark the DMI events as read.

Clear All DMI Event Logs

Select Yes and press <Enter> to clear all DMI event logs. The options are Yes and **No**.

► Console Redirection

Access the submenu to make changes to the following settings.

COM Port Address

This item allows you to specify which COM port to direct the remote console to: Onboard COM A or Onboard COM B. This setting can also be **Disabled**.

BAUD Rate

This item allows you to set the BAUD rate for the console redirection. The options are 300, 1200, 2400, 9600, **19.2K**, 38.4K, 57.6K and 115.2K.

Console Type

This item allows you to choose the console redirection type. The options are VT100, VT100/8bit, PC-ANSI/7bit, **PC ANSI**, VT100+ and VT-UTF8.

Flow Control

This item allows you to set the flow control for the console redirection. The options are None, XON/XOFF and **CTS/RTS**.

Console Connection

This item allows you to decide how the console redirection is to be connected: either **Direct** or Via Modem.

Continue CR after POST

This item allows you to decide whether you want to continue with the console redirection after POST routines. The options are On and **Off**.

► Hardware Monitor Logic

Highlight this and hit <Enter> to see monitor data for the following items:

CPU1 Temperature/CPU1 Secondary Core Temperature/CPU2 Temperature/CPU2 Secondary Core Temperature/CPU 1~CPU4 Temperatures/ System Temperature1

Fan1-Fan3

If the Auto Fan Control feature is enabled, the BIOS will automatically display the status of the fans indicated in this item.

Fan Speed Control Modes

This feature allows the user to decide how the system controls the speeds of the onboard fans. The CPU temperature and the fan speed are correlative. When the CPU on-die temperature increases, the fan speed will also increase, and vice versa. If the option is set to 3-pin fan, the fan speed is controlled by voltage. If the option is set to 4-pin, the fan speed will be controlled by Pulse Width Modulation (PWM). Select 3-pin if your chassis came with 3-pin fan headers. Select 4-pin if your chassis came with 4-pin fan headers. Select Workstation if your system is used as a Workstation. Select Server if your system is used as a Server. Select Disable to disable fan speed control and allow the onboard fans to constantly run at full speed (12V). The Options are: 1. **Disable**, 2. 3-pin (Server), 3. 3-pin (Workstation), 4. 4-pin (Server) and 5. 4-pin (Workstation).

Voltage Monitoring

The following items will be monitored and displayed:

VcoreA/VcoreB, P1V5, +3.3V, 12V, 5Vsb, 5VDD, P_VTT, and Vbatt.

Note: In the Windows OS environment, the Supero Doctor III settings take precedence over the BIOS settings. When first installed, Supero Doctor III adopts the temperature threshold settings previously set in the BIOS. Any subsequent changes to these thresholds must be made within Supero Doctor, since the SD III settings override the BIOS settings. For the Windows OS to adopt the BIOS temperature threshold settings, please change the SDIII settings to be the same as those set in the BIOS.

► **IPMI** (The option is available only when an IPMI card is installed in the system.)

PhoenixBIOS Setup Utility		
Advanced		
IPMI		Item Specific Help
IPMI Specification Version	2.0	Enable/Disable IPMI event logging. Disabling will still log events received via the system interface.
Firmware Version	2.1	
System Event Logging	[Enabled]	
Clear System Event Log	[Disabled]	
Existing Event Log number	282	
Event Log Control		
SYS Firmware Progress	[Disabled]	
BIOS POST Errors	[Enabled]	
BIOS POST Watchdog	[Disabled]	
OS boot Watchdog	[Disabled]	
Timer for loading OS (min)	[10]	
Time out action	[No Action]	

IPMI Specification Version

This item displays the current IPMI Version.

Firmware Version

This item displays the current Firmware Version.

System Event Logging

Select Enabled to enable IPMI Event Logging. When this function is set to Disabled, the system will continue to log events received via system interface. The options are **Enabled** and Disabled.

Clear System Event Logging

Enabling this function to force the BIOS to clear the system event logs during the next cold boot. The options are Enabled and **Disabled**.

Existing Event Log Number

This item displays the number of the existing event log.

Event Log Control

System Firmware Progress

Enabling this function to log POST progress. The options are Enabled and **Disabled**.

BIOS POST Errors

Enabling this function to log POST errors. The options are Enabled and **Disabled**.

BIOS POST Watch Dog

Set to Enabled to enable POST Watch Dog. The options are Enabled and **Disabled**.

OS Boot Watch Dog

Set to Enabled to enable OS Boot Watch Dog. The options are Enabled and **Disabled**.

Timer for Loading OS (Minutes)

This feature allows the user to set the time value (in minutes) for the previous item (OS Boot Watch Dog) by keying-in a desired number in the blank. The default setting is **10** (minutes.) (Please ignore this option when OS Boot Watch Dog is set to "Disabled".)

Time Out Option

This feature allows the user to determine what action to take in an event of a system boot failure. The options are **No Action**, Reset, Power Off and Power Cycles.

► System Event Log/System Event Log (List Mode)

These options display the System Event Log (SEL) and SEL List Mode.

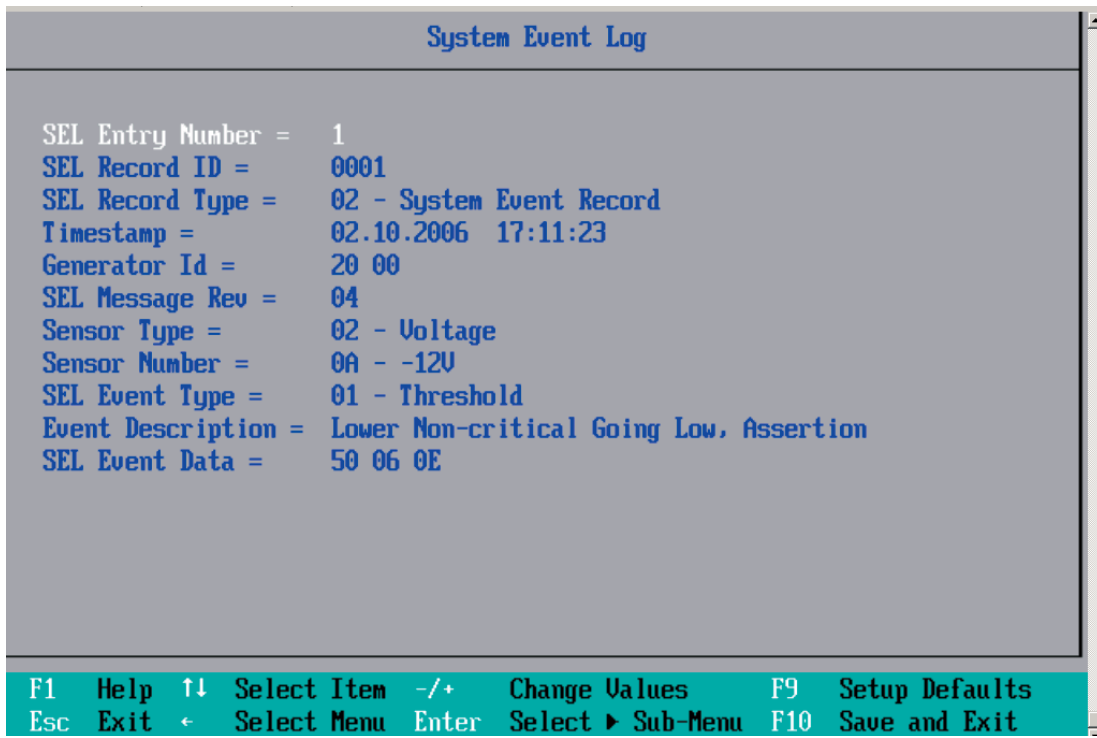

► Realtime Sensor Data

This feature display information from motherboard sensors, such as temperatures, fan speeds and voltages of various components.

Realtime Sensor Data					
Sensor Type	Sensor Name	Sensor Data	Sensor Units	Lower Limit	Upper Limit
Temp					
	CPU1 CoreA	48.00	degrees C	0.00	75.00
	CPU1 CoreB	54.00	degrees C	0.00	75.00
	CPU2 CoreA	47.00	degrees C	0.00	75.00
	CPU2 CoreB	46.00	degrees C	0.00	75.00
	System	44.00	degrees C	0.00	75.00
Voltage					
	CPU1 Core	1.13	Volts	0.97	1.47
	CPU2 Core	1.16	Volts	0.97	1.47
	3.3V	3.30	Volts	2.95	3.62

F1	Help	↑↓	Select Item	-/+	Change Values	F9	Setup Defaults
Esc	Exit	←	Select Menu	Enter	Select ► Sub-Menu	F10	Save and Exit

7-5 Security

Choose Security from the Phoenix BIOS Setup Utility main menu with the arrow keys. You should see the following display. Security setting options are displayed by highlighting the setting using the arrow keys and pressing <Enter>. All Security BIOS settings are described in this section.

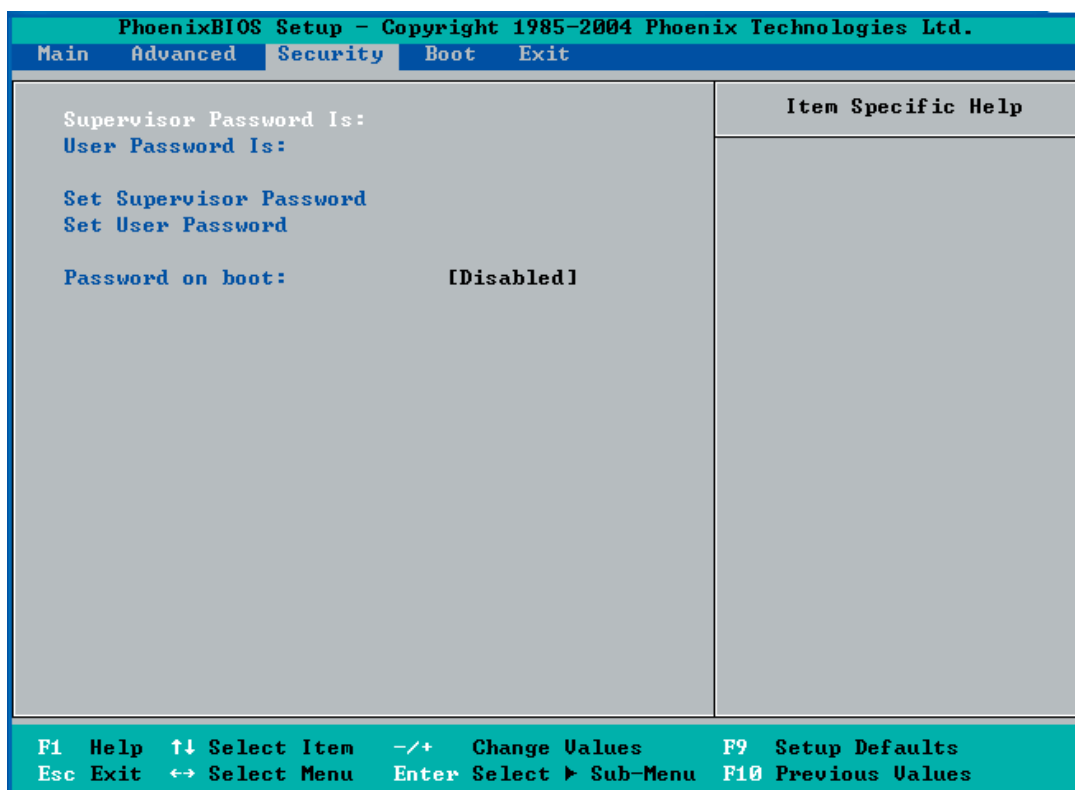

Supervisor Password Is:

This indicates if a supervisor password has been entered for the system. Clear means such a password has not been used and Set means a supervisor password has been entered for the system.

User Password Is:

This indicates if a user password has been entered for the system. Clear means such a password has not been used and Set means a user password has been entered for the system.

Set Supervisor Password

When the item Set Supervisor Password is highlighted, hit the <Enter> key. When prompted, type the Supervisor's password in the dialogue box to set or to change supervisor's password, which allows access to the BIOS.

Set User Password

When the item Set User Password is highlighted, hit the <Enter> key. When prompted, type the user's password in the dialogue box to set or to change the user's password, which allows access to the system at boot-up.

Password on Boot

This setting allows you to determine if a password is required for a user to enter the system at bootup. The options are Enabled (password required) and **Disabled** (password not required).

7-6 Boot

Choose Boot from the Phoenix BIOS Setup Utility main menu with the arrow keys. You should see the following display. See details on how to change the order and specs of boot devices in the Item Specific Help window. All Boot BIOS settings are described in this section.

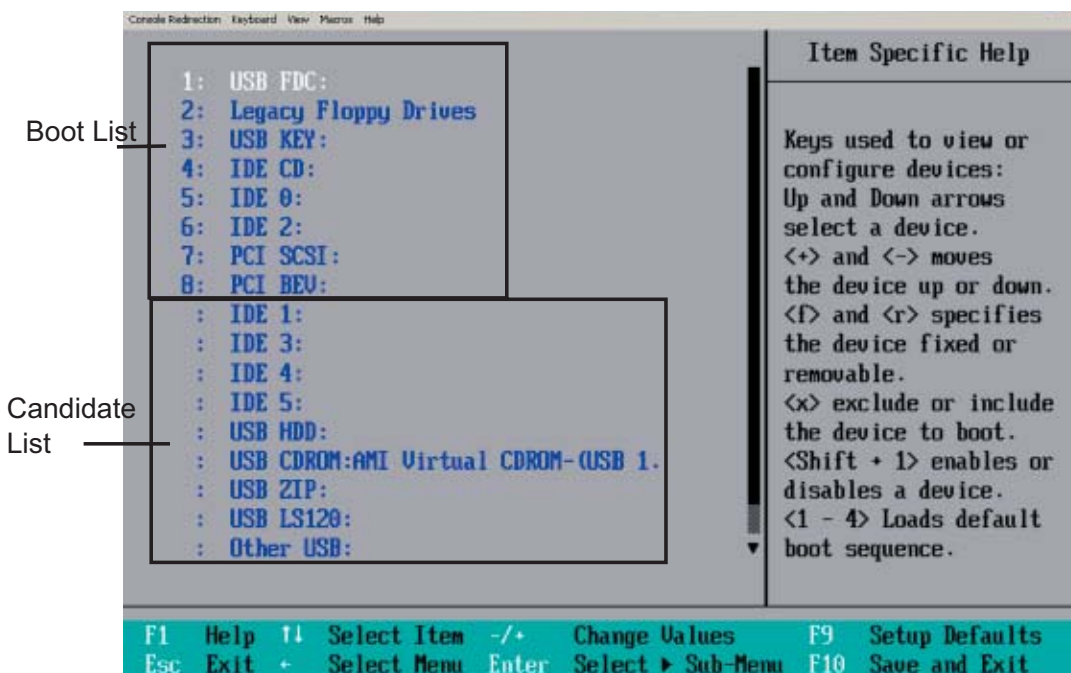

Boot Priority Order/Excluded from Boot Orders

The devices included in the boot list section (above) are bootable devices listed in the sequence of boot order as specified. The boot functions for the devices included in the candidate list (above) are currently disabled. Use a <+> key or a <-> key to move the device up or down. Use the <f> key or the <r> key to specify the type of an USB device, either fixed or removable. You can select one item from the boot list and hit the <x> key to remove it from the list of bootable devices (to make its resource available for other bootable devices). Subsequently, you can select an item from the candidate list and hit the <x> key to remove it from the candidate list and put it in the boot list. This item will then become a bootable device. See details on how to change the priority of boot order of devices in the "Item Specific Help" window.

7-7 Exit

Choose Exit from the Phoenix BIOS Setup Utility main menu with the arrow keys. You should see the following display. All Exit BIOS settings are described in this section.

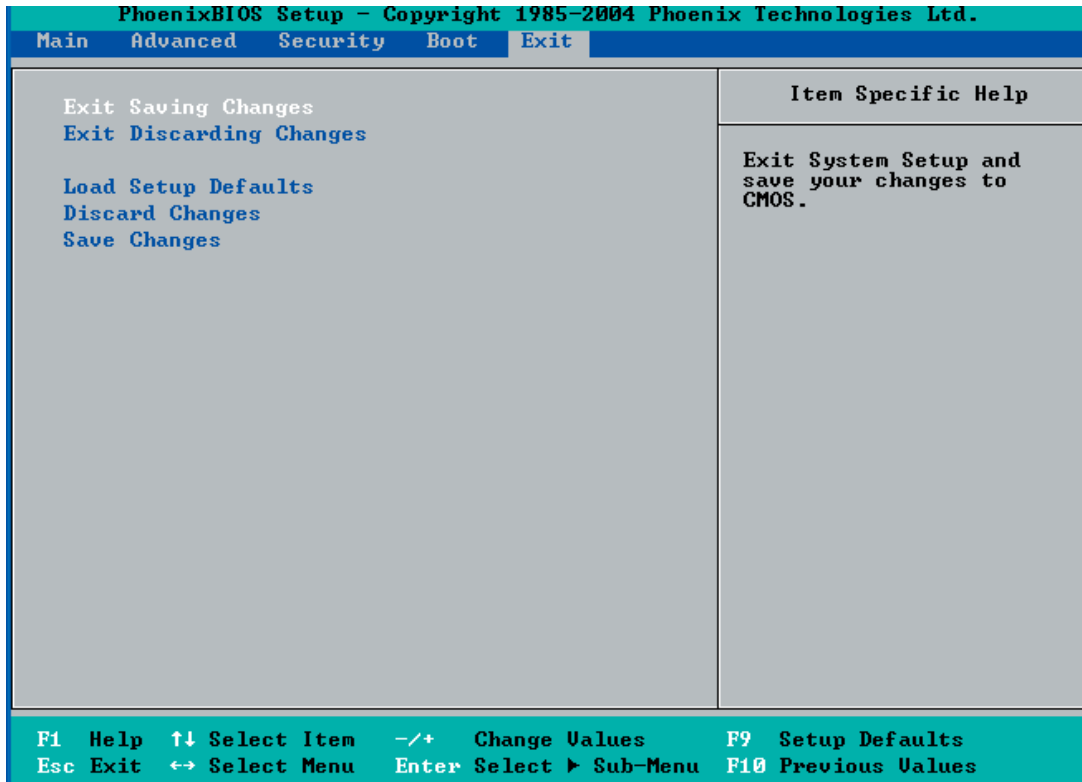

Exit Saving Changes

Highlight this item and hit <Enter> to save any changes you made and to exit the BIOS Setup utility.

Exit Discarding Changes

Highlight this item and hit <Enter> to exit the BIOS Setup utility without saving any changes you may have made.

Load Setup Defaults

Highlight this item and hit <Enter> to load the default settings for all items in the BIOS Setup. These are the safest settings to use.

Discard Changes

Highlight this item and hit <Enter> to discard (cancel) any changes you made. You will remain in the Setup utility.

Save Changes

Highlight this item and hit <Enter> to save any changes you made. You will remain in the Setup utility.

Appendix A

BIOS POST Messages

During the Power-On Self-Test (POST), the BIOS will check for problems. If a problem is found, the BIOS will activate an alarm or display a message. The following is a list of such BIOS messages.

Failure Fixed Disk

Fixed disk is not working or not configured properly. Check to see if fixed disk is attached properly. Run Setup. Find out if the fixed-disk type is correctly identified.

Stuck key

Stuck key on keyboard.

Keyboard error

Keyboard not working.

Keyboard Controller Failed

Keyboard controller failed test. May require replacing keyboard controller.

Keyboard locked - Unlock key switch

Unlock the system to proceed.

Monitor type does not match CMOS - Run SETUP

Monitor type not correctly identified in Setup

Shadow Ram Failed at offset: nnnn

Shadow RAM failed at offset **nnnn** of the 64k block at which the error was detected.

System RAM Failed at offset: nnnn

System RAM failed at offset **nnnn** of in the 64k block at which the error was detected.

Extended RAM Failed at offset: nnnn Extended memory not working or not configured properly at offset **nnnn**.

System battery is dead - Replace and run SETUP

The CMOS clock battery indicator shows the battery is dead. Replace the battery and run Setup to reconfigure the system.

System CMOS checksum bad - Default configuration used

System CMOS has been corrupted or modified incorrectly, perhaps by an application program that changes data stored in CMOS. The BIOS installed Default Setup Values. If you do not want these values, enter Setup and enter your own values. If the error persists, check the system battery or contact your dealer.

System timer error

The timer test failed. Requires repair of system board.

Real time clock error

Real-Time Clock fails BIOS hardware test. May require board repair.

Check date and time settings

BIOS found date or time out of range and reset the Real-Time Clock. May require setting legal date (1991-2099).

Previous boot incomplete - Default configuration used

Previous POST did not complete successfully. POST loads default values and offers to run Setup. If the failure was caused by incorrect values and they are not corrected, the next boot will likely fail. On systems with control of **wait states**, improper Setup settings can also terminate POST and cause this error on the next boot. Run Setup and verify that the waitstate configuration is correct. This error is cleared the next time the system is booted.

Memory Size found by POST differed from CMOS

Memory size found by POST differed from CMOS.

Diskette drive A error

Diskette drive B error

Drive A: or B: is present but fails the BIOS POST diskette tests. Check to see that the drive is defined with the proper diskette type in Setup and that the diskette drive is attached correctly.

Incorrect Drive A type - run SETUP

Type of floppy drive A: not correctly identified in Setup.

Incorrect Drive B type - run SETUP

Type of floppy drive B: not correctly identified in Setup.

System cache error - Cache disabled

RAM cache failed and BIOS disabled the cache. On older boards, check the cache jumpers. You may have to replace the cache. See your dealer. A disabled cache

slows system performance considerably.

CPU ID:

CPU socket number for Multi-Processor error.

EISA CMOS not writeable

ServerBIOS2 test error: Cannot write to EISA CMOS.

DMA Test Failed

ServerBIOS2 test error: Cannot write to extended **DMA** (Direct Memory Access) registers.

Software NMI Failed

ServerBIOS2 test error: Cannot generate software NMI (Non-Maskable Interrupt).

Fail-Safe Timer NMI Failed

ServerBIOS2 test error: Fail-Safe Timer takes too long.

device Address Conflict

Address conflict for specified **device**.

Allocation Error for: device

Run ISA or EISA Configuration Utility to resolve resource conflict for the specified **device**.

CD ROM Drive

CD ROM Drive identified.

Entering SETUP ...

Starting Setup program

Failing Bits: nnnn

The hex number **nnnn** is a map of the bits at the RAM address which failed the memory test. Each 1 (one) in the map indicates a failed bit. See errors 230, 231, or 232 above for offset address of the failure in System, Extended, or Shadow memory.

Fixed Disk n

Fixed disk **n** (0-3) identified.

Invalid System Configuration Data

Problem with NVRAM (CMOS) data.

I/O device IRQ conflict

I/O device IRQ conflict error.

PS/2 Mouse Boot Summary Screen:

PS/2 Mouse installed.

nnnn kB Extended RAM Passed

Where **nnnn** is the amount of RAM in kilobytes successfully tested.

nnnn Cache SRAM Passed

Where **nnnn** is the amount of system cache in kilobytes successfully tested.

nnnn kB Shadow RAM Passed

Where **nnnn** is the amount of shadow RAM in kilobytes successfully tested.

nnnn kB System RAM Passed

Where **nnnn** is the amount of system RAM in kilobytes successfully tested.

One or more I2O Block Storage Devices were excluded from the Setup Boot Menu

There was not enough room in the IPL table to display all installed I2O block-storage devices.

Operating system not found

Operating system cannot be located on either drive A: or drive C:. Enter Setup and see if fixed disk and drive A: are properly identified.

Parity Check 1 nnnn

Parity error found in the system bus. BIOS attempts to locate the address and display it on the screen. If it cannot locate the address, it displays **????**. Parity is a method for checking errors in binary data. A parity error indicates that some data has been corrupted.

Parity Check 2 nnnn

Parity error found in the I/O bus. BIOS attempts to locate the address and display it on the screen. If it cannot locate the address, it displays **????**.

Press <F1> to resume, <F2> to Setup, <F3> for previous

Displayed after any recoverable error message. Press <F1> to start the boot process or <F2> to enter Setup and change the settings. Press <F3> to display the previous screen (usually an initialization error of an **Option ROM**, i.e., an add-on card). Write down and follow the information shown on the screen.

Press <F2> to enter Setup

Optional message displayed during POST. Can be turned off in Setup.

PS/2 Mouse:

PS/2 mouse identified.

Run the I2O Configuration Utility

One or more unclaimed block storage devices have the Configuration Request bit set in the LCT. Run an I2O Configuration Utility (e.g. the SAC utility).

System BIOS shadowed

System BIOS copied to shadow RAM.

UMB upper limit segment address: *nnnn*

Displays the address *nnnn* of the upper limit of **Upper Memory Blocks**, indicating released segments of the BIOS which can be reclaimed by a virtual memory manager.

Video BIOS shadowed

Video BIOS successfully copied to shadow RAM.

Notes

Appendix B

BIOS POST Codes

This section lists the POST (Power On Self Test) codes for the PhoenixBIOS. POST codes are divided into two categories: recoverable and terminal.

Recoverable POST Errors

When a recoverable type of error occurs, BIOS will display an POST code that describes the problem. BIOS may also issue one of the following beep codes:

1 long and two short beeps - video configuration error

1 repetitive long beep - no memory detected

Terminal POST Errors

If a terminal type of error occurs, BIOS will shut down the system but before doing so, will write the error to port 80h, attempt to initialize video and write the error in the top left corner of the screen. The following is a list of codes that may be written to port 80h.

POST Code Description

01h	IPMI Initialization
02h	Verify Real Mode
03h	Disable Non-Maskable Interrupt (NMI)
04h	Get CPU type
06h	Initialize system hardware
07h	Disable shadow and execute code from the ROM.
08h	Initialize chipset with initial POST values
09h	Set IN POST flag
0Ah	Initialize CPU registers
0Bh	Enable CPU cache
0Ch	Initialize caches to initial POST values
0Eh	Initialize I/O component
0Fh	Initialize the local bus IDE
10h	Initialize Power Management
11h	Load alternate registers with initial POST values
12h	Restore CPU control word during warm boot
13h	Reset PCI Bus Mastering devices
14h	Initialize keyboard controller
16h	1-2-2-3 BIOS ROM checksum

POST Code	Description
17h	Initialize cache before memory Auto size
18h	8254 timer initialization
1Ah	8237 DMA controller initialization
1Ch	Reset Programmable Interrupt Controller
20h	1-3-1-1 Test DRAM refresh
22h	1-3-1-3 Test 8742 Keyboard Controller
24h	Set ES segment register to 4 GB
28h	Auto size DRAM
29h	Initialize POST Memory Manager
2Ah	Clear 512 kB base RAM
2Ch	1-3-4-1 RAM failure on address line xxxx*
2Eh	1-3-4-3 RAM failure on data bits xxxx* of low byte of memory bus
2Fh	Enable cache before system BIOS shadow
32h	Test CPU bus-clock frequency
33h	Initialize Phoenix Dispatch Manager
36h	Warm start shut down
38h	Shadow system BIOS ROM
3Ah	Auto size cache
3Ch	Advanced configuration of chipset registers
3Dh	Load alternate registers with CMOS values
41h	Initialize extended memory for RomPilot (optional)
42h	Initialize interrupt vectors
45h	POST device initialization
46h	2-1-2-3 Check ROM copyright notice
48h	Check video configuration against CMOS
49h	Initialize PCI bus and devices
4Ah	Initialize all video adapters in system
4Bh	QuietBoot start (optional)
4Ch	Shadow video BIOS ROM
4Eh	Display BIOS copyright notice
4Fh	Initialize MultiBoot
50h	Display CPU type and speed
51h	Initialize EISA board (optional)
52h	Test keyboard
54h	Set key click if enabled
55h	Enable USB devices
58h	2-2-3-1 Test for unexpected interrupts
59h	Initialize POST display service
5Ah	Display prompt "Press <ESC> to enter SETUP"
5Bh	Disable CPU cache

POST Code	Description
5Ch	Test RAM between 512 and 640 kB
60h	Test extended memory
62h	Test extended memory address lines
64h	Jump to UserPatch1
66h	Configure advanced cache registers
67h	Initialize Multi Processor APIC
68h	Enable external and CPU caches
69h	Setup System Management Mode (SMM) area
6Ah	Display external L2 cache size
6Bh	Load custom defaults (optional)
6Ch	Display shadow-area message
70h	Display error messages
72h	Check for configuration errors
76h	Check for keyboard errors
7Ch	Set up hardware interrupt vectors
7Dh	Initialize Intelligent System Monitoring (optional)
7Eh	Initialize coprocessor if present
80h	Disable onboard Super I/O ports and IRQs (optional)
81h	Late POST device initialization
82h	Detect and install external RS232 ports
83h	Configure non-MCD IDE controllers
84h	Detect and install external parallel ports
85h	Initialize PC-compatible PnP ISA devices
86h	Re-initialize onboard I/O ports.
87h	Configure Motherboard Configurable Devices (optional)
88h	Initialize BIOS Data Area
89h	Enable Non-Maskable Interrupts (NMIs)
8Ah	Initialize Extended BIOS Data Area
8Bh	Test and initialize PS/2 mouse
8Ch	Initialize floppy controller
8Fh	Determine number of ATA drives (optional)
90h	Initialize hard-disk controllers
91h	Initialize local-bus hard-disk controllers
92h	Jump to UserPatch2
93h	Build MPTABLE for multi-processor boards
95h	Install CD ROM for boot
96h	Clear huge ES segment register
97h	Fix up Multi Processor table
98h	1-2 Search for option ROMs and shadow if successful. One long, two short beeps on checksum failure

POST Code	Description
99h	Check for SMART Drive (optional)
9Ch	Set up Power Management
9Dh	Initialize security engine (optional)
9Eh	Enable hardware interrupts
9Fh	Determine number of ATA and SCSI drives
A0h	Set time of day
A2h	Check key lock
A4h	Initialize typematic rate
A8h	Erase <ESC> prompt
AAh	Scan for <ESC> key stroke
ACh	Enter SETUP
AEh	Clear Boot flag
B0h	Check for errors
B1h	Inform RomPilot about the end of POST (optional)
B2h	POST done - prepare to boot operating system
B4h	1 One short beep before boot
B5h	Terminate QuietBoot (optional)
B6h	Check password (optional)
B7h	Initialize ACPI BIOS and PPM Structures
B9h	Prepare Boot
BAh	Initialize SMBIOS
BCh	Clear parity checkers
BDh	Display MultiBoot menu
BEh	Clear screen (optional)
BFh	Check virus and backup reminders
C0h	Try to boot with INT 19
C1h	Initialize POST Error Manager (PEM)
C2h	Initialize error logging
C3h	Initialize error display function
C4h	Initialize system error flags
C6h	Console redirection init.
C7h	Unhook INT 10h if console redirection enabled
C8h	Force check (optional)
C9h	Extended ROM checksum (optional)
CDh	Reclaim console redirection vector
D2h	Unknown interrupt
D4h	Check Intel Branding string
D8h	Alert Standard Format initialization
D9h	Late init for IPMI
DEh	Log error if micro-code not updated properly

The following are for the boot block in Flash ROM

POST Code	Description
E0h	Initialize the chipset
E1h	Initialize the bridge
E2h	Initialize the CPU
E3h	Initialize system timer
E4h	Initialize system I/O
E5h	Check force recovery boot
E6h	Checksum BIOS ROM
E7h	Go to BIOS
E8h	Set Huge Segment
E9h	Initialize Multi Processor
EAh	Initialize OEM special code
EBh	Initialize PIC and DMA
ECh	Initialize Memory type
EDh	Initialize Memory size
EEh	Shadow Boot Block
EFh	System memory test
F0h	Initialize interrupt vectors
F1h	Initialize Run Time Clock
F2h	Initialize video
F3h	Initialize System Management Manager
F4h	Output one beep
F5h	Clear Huge Segment
F6h	Boot to Mini DOS
F7h	Boot to Full DOS

If the BIOS detects errors on 2C, 2E, or 30 (base 512K RAM error), it displays an additional word-bitmap (**xxxx**) indicating the address line or bits that have failed. For example, "2C 0002" means address line 1 (bit one set) has failed. "2E 1020" means data bits 12 and 5 (bits 12 and 5 set) have failed in the lower 16 bits. The BIOS also sends the bitmap to the port-80 LED display. It first displays the checkpoint code, followed by a delay, the high-order byte, another delay, and then the low order byte of the error. It repeats this sequence continuously.

Notes

Appendix C

System Specifications

Note: unless otherwise noted, specs apply to a complete system (both serverboards).

Processors

Four Intel® Xeon® 5400/5300/5200/5100 Series processors in LGA771 sockets

Note: please refer to our website for details on supported processors.

Chipset

Intel 5100/ICH9R

BIOS

Phoenix BIOS in 16 Mb Flash EEPROM (each serverboard)

Memory Capacity

Twelve DIMM slots to support a maximum up to 96 GB of registered ECC DDR2-667/533 SDRAM (48 GB per node)

Note: interleaved memory requires DIMMs to be installed in pairs - refer to Section 5-6 for details.

Serial ATA Controller

Intel ICH9R on-chip controller to support eight 3 Gb/s Serial ATA [RAID 0, 1, 5 (Windows only) and 10]

SATA Drive Bays

Eight hot-swap drive bays to house eight standard SATA drives

PCI Expansion

Two low-profile PCI-Express x16 slots (with pre-installed riser cards)

Serverboard

1025TC-T: X7DCT

1025TC-10G: X7DCT-10G

Dimensions (both): 6.5 x 16.4 in (165 x 417 mm)

Chassis

SC809T-780B (1U Rackmount)

Dimensions: (WxHxD) 17.2 x 1.7 x 27.75 in. (437 x 43 x 705 mm)

Weight

Gross Weight: 40 lbs. (18.2 kg.)

System Cooling

Six (6) high-performance 4-cm PWM (Pulse Width Modulated) fans

System Input Requirements

AC Input Voltage: 100 - 240V AC auto-range

Rated Input Current: 9.5 - 6A max @ 700W, 5 - 3.5A @ 780W*

Rated Input Frequency: 50 to 60 Hz

*Power supply operates at 700W with a 100-140V input and at 780W with a 180-240V input

Power Supply

Rated Output Power: 780W w/ PFC (Part# PWS-781-1S)

Rated Output Voltages: +12V (65A @ 180-240AC, 58A @ 100-140AC), +5Vsb (4A)

Operating Environment

Operating Temperature: 10° to 35° C (50° to 95° F)

Non-operating Temperature: -40° to 70° C (-40° to 158° F)

Operating Relative Humidity: 8% to 90% (non-condensing)

Non-operating Relative Humidity: 5 to 95% (non-condensing)

Regulatory Compliance

Electromagnetic Emissions:

FCC Class A, EN 55022 Class A, EN 61000-3-2/-3-3, CISPR 22 Class A

Electromagnetic Immunity:

EN 55024/CISPR 24, (EN 61000-4-2, EN 61000-4-3, EN 61000-4-4, EN 61000-4-5, EN 61000-4-6, EN 61000-4-8, EN 61000-4-11)

Safety:

EN 60950/IEC 60950-Compliant

UL Listed (USA)

CUL Listed (Canada)

TUV Certified (Germany)

CE Marking (Europe)

California Best Management Practices Regulations for Perchlorate Materials:

This Perchlorate warning applies only to products containing CR (Manganese Dioxide) Lithium coin cells. "Perchlorate Material-special handling may apply. See www.dtsc.ca.gov/hazardouswaste/perchlorate"

Disclaimer (cont.)

The products sold by Supermicro are not intended for and will not be used in life support systems, medical equipment, nuclear facilities or systems, aircraft, aircraft devices, aircraft/emergency communication devices or other critical systems whose failure to perform be reasonably expected to result in significant injury or loss of life or catastrophic property damage. Accordingly, Supermicro disclaims any and all liability, and should buyer use or sell such products for use in such ultra-hazardous applications, it does so entirely at its own risk. Furthermore, buyer agrees to fully indemnify, defend and hold Supermicro harmless for and against any and all claims, demands, actions, litigation, and proceedings of any kind arising out of or related to such ultra-hazardous use or sale.

Notes