

# SUPERO<sup>®</sup>

## SUPERSERVER 6016T-MR

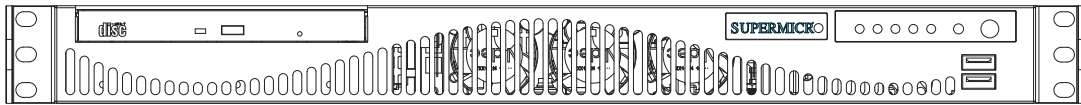

## USER'S MANUAL

Revision 1.0a

The information in this User's Manual has been carefully reviewed and is believed to be accurate. The vendor assumes no responsibility for any inaccuracies that may be contained in this document, makes no commitment to update or to keep current the information in this manual, or to notify any person or organization of the updates. **Please Note: For the most up-to-date version of this manual, please see our web site at [www.supermicro.com](http://www.supermicro.com).**

Super Micro Computer, Inc. ("Supermicro") reserves the right to make changes to the product described in this manual at any time and without notice. This product, including software and documentation, is the property of Supermicro and/or its licensors, and is supplied only under a license. Any use or reproduction of this product is not allowed, except as expressly permitted by the terms of said license.

IN NO EVENT WILL SUPERMICRO BE LIABLE FOR DIRECT, INDIRECT, SPECIAL, INCIDENTAL, SPECULATIVE OR CONSEQUENTIAL DAMAGES ARISING FROM THE USE OR INABILITY TO USE THIS PRODUCT OR DOCUMENTATION, EVEN IF ADVISED OF THE POSSIBILITY OF SUCH DAMAGES. IN PARTICULAR, SUPERMICRO SHALL NOT HAVE LIABILITY FOR ANY HARDWARE, SOFTWARE, OR DATA STORED OR USED WITH THE PRODUCT, INCLUDING THE COSTS OF REPAIRING, REPLACING, INTEGRATING, INSTALLING OR RECOVERING SUCH HARDWARE, SOFTWARE, OR DATA.

Any disputes arising between manufacturer and customer shall be governed by the laws of Santa Clara County in the State of California, USA. The State of California, County of Santa Clara shall be the exclusive venue for the resolution of any such disputes. Super Micro's total liability for all claims will not exceed the price paid for the hardware product.

FCC Statement: This equipment has been tested and found to comply with the limits for a Class A digital device pursuant to Part 15 of the FCC Rules. These limits are designed to provide reasonable protection against harmful interference when the equipment is operated in a commercial environment. This equipment generates, uses, and can radiate radio frequency energy and, if not installed and used in accordance with the manufacturer's instruction manual, may cause harmful interference with radio communications. Operation of this equipment in a residential area is likely to cause harmful interference, in which case you will be required to correct the interference at your own expense.

California Best Management Practices Regulations for Perchlorate Materials: This Perchlorate warning applies only to products containing CR (Manganese Dioxide) Lithium coin cells. "Perchlorate Material-special handling may apply. See [www.dtsc.ca.gov/hazardouswaste/perchlorate](http://www.dtsc.ca.gov/hazardouswaste/perchlorate)"

**WARNING: Handling of lead solder materials used in this product may expose you to lead, a chemical known to the State of California to cause birth defects and other reproductive harm.**

Manual Revision 1.0a  
Release Date: August 9, 2010

Unless you request and receive written permission from Super Micro Computer, Inc., you may not copy any part of this document.

Information in this document is subject to change without notice. Other products and companies referred to herein are trademarks or registered trademarks of their respective companies or mark holders.

Copyright © 2010 by Super Micro Computer, Inc.  
All rights reserved.

**Printed in the United States of America**

# Preface

## About This Manual

This manual is written for professional system integrators and PC technicians. It provides information for the installation and use of the SuperServer 6016T-MR. Installation and maintenance should be performed by experienced technicians only.

The SuperServer 6016T-MR is a 1U rackmount server based on the SC512F-520B server chassis and the Super X8DTL-i serverboard. Please refer to our web site for updates on supported processors.

## Manual Organization

### Chapter 1: Introduction

The first chapter provides a checklist of the main components included with the server system and describes the main features of the Super X8DTL-i serverboard and the SC512F-520B chassis.

### Chapter 2: Server Installation

This chapter describes the steps necessary to install the SuperServer 6016T-MR into a rack and check out the server configuration prior to powering up the system. If your server was ordered without the processor and memory components, this chapter will refer you to the appropriate sections of the manual for their installation.

### Chapter 3: System Interface

Refer to this chapter for details on the system interface, which includes the functions and information provided by the control panel on the chassis as well as other LEDs located throughout the system.

## **Chapter 4: System Safety**

You should thoroughly familiarize yourself with this chapter for a general overview of safety precautions that should be followed when installing and servicing the SuperServer 6016T-MR.

## **Chapter 5: Advanced Serverboard Setup**

Chapter 5 provides detailed information on the X8DTL-i serverboard, including the locations and functions of connectors, headers and jumpers. Refer to this chapter when adding or removing processors or main memory and when reconfiguring the serverboard.

## **Chapter 6: Advanced Chassis Setup**

Refer to Chapter 6 for detailed information on the SC512F-520B chassis. You should follow the procedures given in this chapter when installing, removing or reconfiguring Serial ATA or peripheral drives and when replacing system power supply units and cooling fans.

## **Chapter 7: BIOS**

The BIOS chapter includes an introduction to BIOS and provides detailed information on running the CMOS Setup Utility.

## **Appendix A: BIOS POST Error Codes**

## **Appendix B: Installing Windows**

## **Appendix C: System Specifications**

## Notes

## Table of Contents

### **Preface**

About This Manual .....	iii
Manual Organization .....	iii

### **Chapter 1 Introduction**

1-1	Overview .....	1-1
1-2	Serverboard Features .....	1-2
	Processor .....	1-2
	Memory .....	1-2
	Serial ATA .....	1-2
	PCI Expansion Slots .....	1-2
	Backpanel Ports .....	1-2
1-3	Server Chassis Features .....	1-4
	Serial ATA Subsystem .....	1-4
	Control Panel .....	1-4
	Rear I/O Panel .....	1-4
	Cooling System .....	1-4
1-4	Contacting Supermicro.....	1-5

### **Chapter 2 Server Installation**

2-1	Overview .....	2-1
2-2	Unpacking the System .....	2-1
2-3	Preparing for Setup.....	2-1
	Choosing a Setup Location.....	2-2
	Rack Precautions .....	2-2
	Server Precautions.....	2-2
	Rack Mounting Considerations .....	2-3
	Ambient Operating Temperature .....	2-3
	Reduced Airflow .....	2-3
	Mechanical Loading .....	2-3
	Circuit Overloading.....	2-3
	Reliable Ground .....	2-3
2-4	Installing the System into a Rack .....	2-4
	Basic Installation Procedure .....	2-4
	Installing with Rackmount Kit.....	2-5
2-5	Checking the Serverboard Setup.....	2-9
2-6	Checking the Drive Bay Setup.....	2-10

---

**Chapter 3 System Interface**

3-1	Overview .....	3-1
3-2	Control Panel Buttons .....	3-1
	Reset .....	3-1
	Power .....	3-1
3-3	Control Panel LEDs .....	3-2
	Overheat/Fan Fail .....	3-2
	NIC2 .....	3-2
	NIC1 .....	3-2
	HDD.....	3-3
	Power .....	3-3

**Chapter 4 System Safety**

4-1	Electrical Safety Precautions .....	4-1
4-2	General Safety Precautions .....	4-2
4-3	ESD Precautions .....	4-3
4-4	Operating Precautions .....	4-4

**Chapter 5 Advanced Serverboard Setup**

5-1	Handling the Serverboard .....	5-1
	Precautions .....	5-1
	Unpacking .....	5-2
5-2	Serverboard Installation .....	5-2
5-3	Connecting Cables.....	5-3
	Connecting Data Cables .....	5-3
	Connecting Power Cables .....	5-3
	Connecting the Control Panel.....	5-3
5-4	Rear I/O Ports .....	5-4
5-5	Installing the Processor and Heatsink .....	5-5
	Installing an LGA1366 Processor .....	5-5
	Installing a Passive CPU Heatsink .....	5-7
	Removing the Heatsink.....	5-8
5-6	Installing Memory Modules .....	5-9
	Installing & Removing DIMMs.....	5-9
	Memory Support.....	5-10
	Populating DIMMs .....	5-10
5-7	Adding PCI Cards .....	5-11
5-8	Serverboard Details .....	5-12
	Serverboard Layout.....	5-12
	X8DTL-i Quick Reference .....	5-13

5-9	Connector Definitions .....	5-14
	ATX Power Connector.....	5-14
	Processor Power Connector .....	5-14
	PW_ON Connector.....	5-14
	Reset Connector .....	5-14
	Power Fail LED .....	5-15
	Overheat LED (OH).....	5-15
	NIC2 (LAN2) LED.....	5-15
	NIC1 (LAN1) LED.....	5-15
	HDD LED.....	5-15
	Power On LED .....	5-16
	NMI Button .....	5-16
	Fan Headers.....	5-16
	ATX PS/2 Keyboard and PS/2 Mouse Ports.....	5-16
	Chassis Intrusion.....	5-16
	Universal Serial Bus (USB).....	5-17
	Serial Ports.....	5-17
	Wake-On-LAN .....	5-17
	Onboard Speaker (SP1).....	5-18
	Power LED/Speaker.....	5-18
	SGPIO Headers .....	5-18
	I-Button.....	5-18
	LAN1/2 (Ethernet Ports).....	5-19
	Power SMB (I <sup>2</sup> C) Header .....	5-19
	IPMB.....	5-19
	Overheat LED/Fan Fail (JOH1).....	5-19
	Unit Identifier Button.....	5-19
5-10	Jumper Settings .....	5-20
	Explanation of Jumpers .....	5-20
	CMOS Clear .....	5-20
	VGA Enable/Disable.....	5-20
	LAN1/LAN2 Enable/Disable .....	5-21
	Watch Dog.....	5-21
	I <sup>2</sup> C Bus to PCI/PCI-Exp. Slots .....	5-21
5-11	Onboard Indicators.....	5-22
	LAN1/LAN2 LEDs.....	5-22
	Onboard Power LED .....	5-22
	Rear UID LED .....	5-22
5-12	SATA Port Connections.....	5-23

---

---

	SATA Ports .....	5-23
5-13	Installing Software.....	5-24
	Supero Doctor III.....	5-25

### **Chapter 6 Advanced Chassis Setup**

6-1	Static-Sensitive Devices.....	6-1
	Precautions .....	6-1
6-2	Control Panel .....	6-2
6-3	System Fans .....	6-3
	System Fan Failure.....	6-3
6-4	Drive Bay Installation/Removal .....	6-4
	Accessing the Drive Bays .....	6-4
	DVD-ROM Drive Installation .....	6-5
6-5	Power Supply .....	6-7
	Power Supply Failure.....	6-7

### **Chapter 7 BIOS**

7-1	Introduction.....	7-1
	Starting BIOS Setup Utility.....	7-1
	How To Change the Configuration Data .....	7-1
	Starting the Setup Utility .....	7-2
7-2	Main Setup .....	7-2
7-3	Advanced Setup Configurations.....	7-4
	Power Configuration.....	7-5
7-4	Security Settings .....	7-24
7-5	Boot Configuration .....	7-25
7-6	Exit Options.....	7-27

### **Appendix A BIOS Post Error Codes**

### **Appendix B Installing Windows**

### **Appendix C System Specifications**

# Notes

# Chapter 1

## Introduction

### 1-1 Overview

The Supermicro SuperServer 6016T-MR is a 1U rackmount server designed for optimal space efficiency. The 6016T-MR is comprised of two main subsystems: the SC512F-520B 1U chassis and the X8DTL-i serverboard. Please refer to our web site for information on operating systems that have been certified for use with the 6016T-MR.

In addition to the mainboard and chassis, various hardware components may have been included with the 6016T-MR, as listed below.

- One CPU heatsink (SNK-P0037P, for CPU1)
- One CPU heatsink (SNK-P0041, for CPU2)
- Four (4) 4-cm fans (FAN-0087L4)
- One (1) air shroud (MCP-310-18003-0N)
- SATA Accessories:
  - One (1) internal SATA backplane (BPN-SAS-815TQ)
  - One (1) set of SATA cables (CBL-0186L)
  - One (1) SGPIO cable (CBL-0157L)
  - Four (4) SATA drive carriers [CSE-PT39 (B)]
- One (1) PCI-E x8 slot riser card (CSE-RR1U-E8)
- One (1) CD containing drivers and utilities
- SuperServer 6016T-MR User's Manual

Optional:

- Rackmount kit (MCP-290-00004-03)

Note: "B" indicates black.

## 1-2 Serverboard Features

The X8DTL-i is a dual processor serverboard based upon Intel's 5500 + ICH10R chipset. Below are the main features of the X8DTL-i.

### Processor

The X8DTL-i supports single or dual two Intel® 5600/5500 Series processors in LGA1366 sockets. Please refer to our web site for a complete listing of supported processors ([www.supermicro.com](http://www.supermicro.com)).

### Memory

The X8DTL-i has six 240-pin DIMM slots that can support up to 48 GB of ECC registered or 24 GB of unbuffered DDR3-1333/1066/800 SDRAM.

### Serial ATA

An on-chip (ICH10R) SATA controller is integrated into the X8DTL-i to provide a six-port, 3 Gb/sec SATA subsystem, which is RAID 0, 1, 5 and 10 supported. The SATA drives are hot-swappable units. For more information on SATA HostRAID configuration, please refer to the Intel SATA HostRAID User's Guide posted on our website at <http://www.supermicro.com/support/manuals/>.

**Note:** You must have RAID set up to enable the hot-swap capability of the SATA drives.

### PCI Expansion Slots

The X8DTL-i has two PCI Express 2.0 x8 slots, one PCI Express 2.0 x4 slot, one PCI Express x4 slot and two PCI 33 MHz slots. One of these slots may be populated with a PCI-E x16 riser card (included) to support a PCI expansion card with a PCI-E x8 signal.

### Backpanel Ports

Onboard I/O backpanel ports include one COM port, a VGA port, two USB ports, PS/2 mouse and keyboard ports and two Gigabit LAN (NIC) ports. A UID button is also included on the backpanel.

## Other Features

Other onboard features that promote system health include voltage monitors, a chassis intrusion header, auto-switching voltage regulators, chassis and CPU overheat sensors, virus protection and BIOS rescue.

**Figure 1-1. Intel 5500 Chipset: System Block Diagram**

**Note:** This is a general block diagram. Please see Chapter 5 for details.

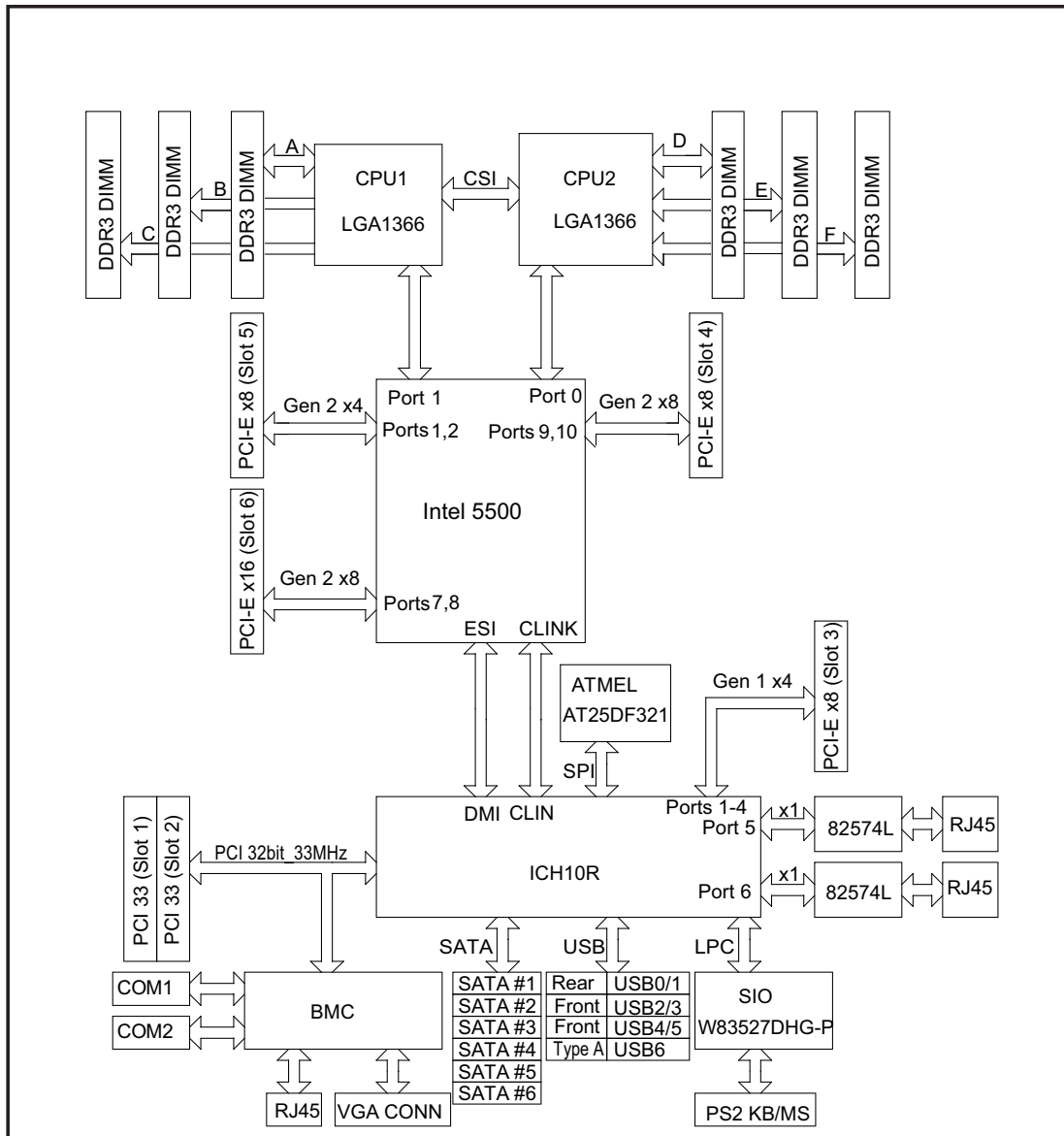

## 1-3 Server Chassis Features

The SuperServer 6016T-MR is built on the SC512F-520B 1U rackmount server chassis. The following is a general outline of the main features of the SC512F-520B chassis.

### System Power

When configured as the SuperServer 6016T-MR, the SC512F-520B chassis features a single power supply.

### Serial ATA Subsystem

The SC512F-520B chassis is designed to support one internal SATA hard drive. The internal drive is not hot-swappable.

### Control Panel

The SC512F-520B's control panel provides important system monitoring and control information. LEDs indicate power on, network activity, hard disk drive activity, overheat warning and fan failure. The control panel also includes a main power button and a reset button.

### Rear I/O Panel

The rear I/O panel on the chassis provides one PCI expansion card slot, one COM port (another is internal), two USB ports, PS/2 mouse and keyboard ports, a VGA (graphics) port and two Gb Ethernet ports. (See Chapter 6 for diagram.)

### Cooling System

The SC512F-520B chassis has an innovative cooling design that features an air shroud and three 4-cm counter-rotating fans with user-defined fan speed control. (Fan speed may be defined with a BIOS setting.)

## 1-4 Contacting Supermicro

### Headquarters

Address: Super Micro Computer, Inc.  
980 Rock Ave.  
San Jose, CA 95131 U.S.A.

Tel: +1 (408) 503-8000

Fax: +1 (408) 503-8008

Email: marketing@supermicro.com (General Information)  
support@supermicro.com (Technical Support)

Web Site: www.supermicro.com

### Europe

Address: Super Micro Computer B.V.  
Het Sterrenbeeld 28, 5215 ML  
's-Hertogenbosch, The Netherlands

Tel: +31 (0) 73-6400390

Fax: +31 (0) 73-6416525

Email: sales@supermicro.nl (General Information)  
support@supermicro.nl (Technical Support)  
rma@supermicro.nl (Customer Support)

### Asia-Pacific

Address: Super Micro Computer, Inc.  
4F, No. 232-1, Liancheng Rd.  
Chung-Ho 235, Taipei County  
Taiwan, R.O.C.

Tel: +886-(2) 8226-3990

Fax: +886-(2) 8226-3991

Web Site: www.supermicro.com.tw

Technical Support:

Email: support@supermicro.com.tw

Tel: 886-2-8228-1366, ext.132 or 139

**Notes**

# Chapter 2

## Server Installation

### 2-1 Overview

This chapter provides a quick setup checklist to get your SuperServer 6016T-MR up and running. Following the steps in the order given should enable you to have the system operational within a minimal amount of time. This quick setup assumes that your system has come to you with the processor and memory preinstalled. If your system is not already fully integrated with a serverboard, processor, system memory etc., please turn to the chapter or section noted in each step for details on installing specific components.

### 2-2 Unpacking the System

You should inspect the box the server was shipped in and note if it was damaged in any way. If the server itself shows damage, you should file a damage claim with the carrier who delivered it.

Decide on a suitable location for the rack unit that will hold the server. It should be situated in a clean, dust-free area that is well ventilated. Avoid areas where heat, electrical noise and electromagnetic fields are generated. You will also need it placed near a grounded power outlet. Read the Rack and Server Precautions in the next section.

### 2-3 Preparing for Setup

The SuperServer 6016T-MR does not ship with a rack rail hardware package as the system can be rack mounted without the use of rails. An optional rack rail package is available if you wish to order from Supermicro. Follow the steps in the order given to complete the installation process in a minimal amount of time. Please read this section in its entirety before you begin the installation procedure outlined in the sections that follow.

## Choosing a Setup Location

- Leave enough clearance in front of the rack to enable you to open the front door completely (~25 inches) and approximately 30 inches of clearance in the back of the rack to allow for sufficient airflow and ease in servicing. This product is for installation only in a Restricted Access Location (dedicated equipment rooms, service closets and the like).
- This product is not suitable for use with visual display work place devices according to §2 of the the German Ordinance for Work with Visual Display Units.



### Warnings and Precautions!



#### Rack Precautions

- Ensure that the leveling jacks on the bottom of the rack are fully extended to the floor with the full weight of the rack resting on them.
- In single rack installation, stabilizers should be attached to the rack. In multiple rack installations, the racks should be coupled together.
- Always make sure the rack is stable before extending a component from the rack.
- You should extend only one component at a time - extending two or more simultaneously may cause the rack to become unstable.

#### Server Precautions

- Review the electrical and general safety precautions in Chapter 4.
- Determine the placement of each component in the rack *before* you install the rails.
- Install the heaviest server components on the bottom of the rack first, and then work up.
- Use a regulating uninterruptible power supply (UPS) to protect the server from power surges, voltage spikes and to keep your system operating in case of a power failure.

- Allow the hot plug SATA drives and power supply modules to cool before touching them.
- Always keep the rack's front door and all panels and components on the servers closed when not servicing to maintain proper cooling.

## **Rack Mounting Considerations**

### **Ambient Operating Temperature**

If installed in a closed or multi-unit rack assembly, the ambient operating temperature of the rack environment may be greater than the ambient temperature of the room. Therefore, consideration should be given to installing the equipment in an environment compatible with the manufacturer's maximum rated ambient temperature ( $T_{mra}$ ).

### **Reduced Airflow**

Equipment should be mounted into a rack so that the amount of airflow required for safe operation is not compromised.

### **Mechanical Loading**

Equipment should be mounted into a rack so that a hazardous condition does not arise due to uneven mechanical loading.

### **Circuit Overloading**

Consideration should be given to the connection of the equipment to the power supply circuitry and the effect that any possible overloading of circuits might have on overcurrent protection and power supply wiring. Appropriate consideration of equipment nameplate ratings should be used when addressing this concern.

### **Reliable Ground**

A reliable ground must be maintained at all times. To ensure this, the rack itself should be grounded. Particular attention should be given to power supply connections other than the direct connections to the branch circuit (i.e. the use of power strips, etc.).

## 2-4 Installing the System into a Rack

This section provides information on installing the SuperServer 6016T-MR into a rack unit. If the system has already been mounted into a rack, you can skip ahead to Sections 2-5 and 2-6.

**Note:** the server may be installed as is - rack hardware is optional.

### Basic Installation Procedure

The 6016T-MR server comes with two rack mounting brackets, which are located on each side at the front of the chassis. To mount the system into a rack, simply screw these brackets directly to the front of the rack (two screws for each bracket). As Figure 2-1 shows, the brackets can be located at the front of the chassis (left figure) or moved approximately one-third to the rear of the chassis (right figure).

**Figure 2-1. Identifying the Sections of the Rack Rails**

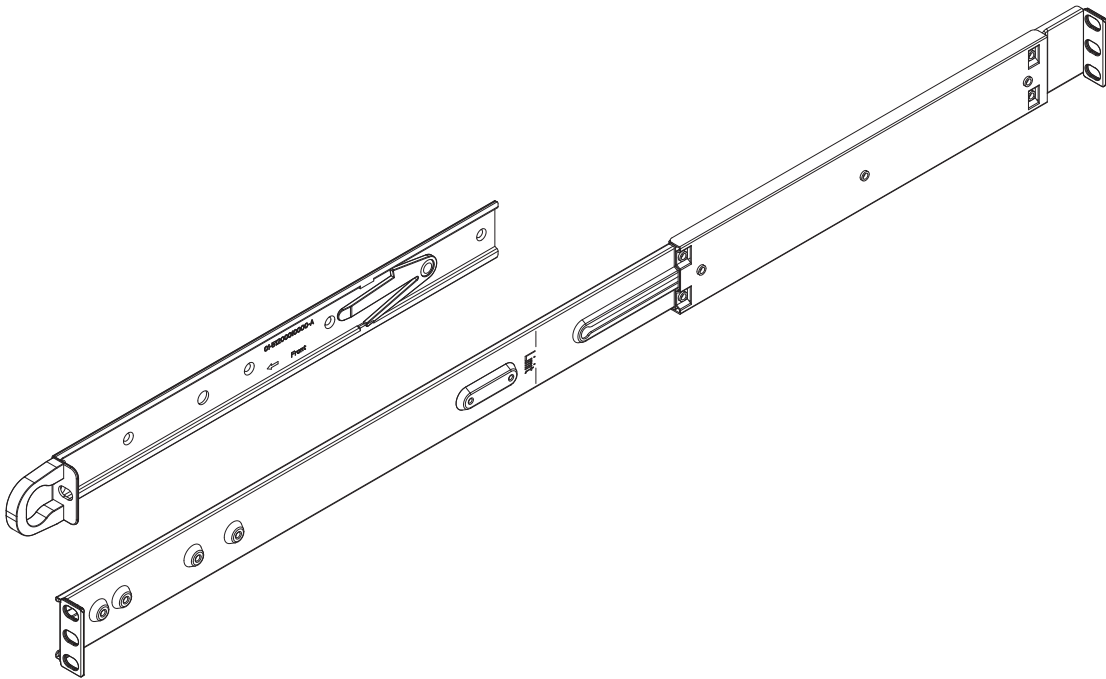

## Installing with Rackmount Kit

This is a guideline for installing the unit into a rack with the optional rack kit (MCP-290-00004-03). You should also refer to the installation instructions that came with the rack unit you are using. Be aware that there are a variety of rack units on the market, which may mean the assembly procedure will differ slightly.

The rack hardware includes two assemblies that consists of two sections: an inner rail that secures to the chassis and an outer rail that secures directly to the rack itself (see Figure 2-1).

### *Installing the Chassis Rails*

1. Detach the two rail sections from each other by depressing the locking tab on the inner rail to release it from its locked position, then pull the two rails completely apart.
2. Repeat step 1 for the remaining rail assembly.
3. Position the fixed chassis rail sections you just removed along the side of the chassis making sure the three screw holes line up. Note that the rails are left/right side specific.
4. Screw the rail securely to the side of the chassis (see Figure 2-2). Repeat this procedure for the other rail on the other side of the chassis. You will also need to attach the rail brackets when installing into a telco rack.

**Locking Tabs:** Both chassis rails have a locking tab, which serves two functions. The first is to lock the server into place when installed and pushed fully into the rack, which is its normal position. Secondly, these tabs also lock the server in place when fully extended from the rack. This prevents the server from coming completely out of the rack when you pull it out for servicing.

**Figure 2-2. Installing Chassis Rails**

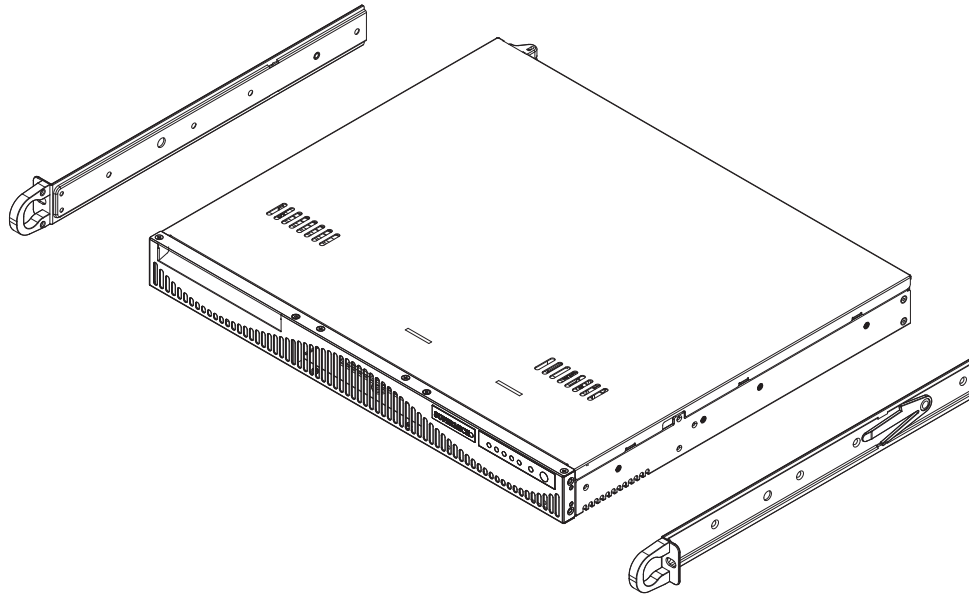

### ***Installing the Rack Rails***

1. Determine where you want to place the 6016T-MR in the rack (see Rack and Server Precautions in Section 2-3).
2. Position the fixed rack rail/sliding rail guide assemblies at the desired location in the rack, keeping the sliding rail guide facing the inside of the rack.
3. Screw the assembly securely to the rack using the brackets provided.
4. Attach the other assembly to the other side of the rack, making sure that both are at the exact same height and with the rail guides facing inward.

### ***Installing the Server into the Rack***

You should now have rails attached to both the chassis and the rack unit. The next step is to install the server into the rack.

1. Line up the rear of the chassis rails with the front of the rack rails.
2. Slide the chassis rails into the rack rails, keeping the pressure even on both sides (you may have to depress the locking tabs when inserting). See Figure 2-3.
3. When the server has been pushed completely into the rack, you should hear the locking tabs "click".

**Figure 2-3. Installing the Server into a Rack  
(w/ Optional Rackmount Kit)**

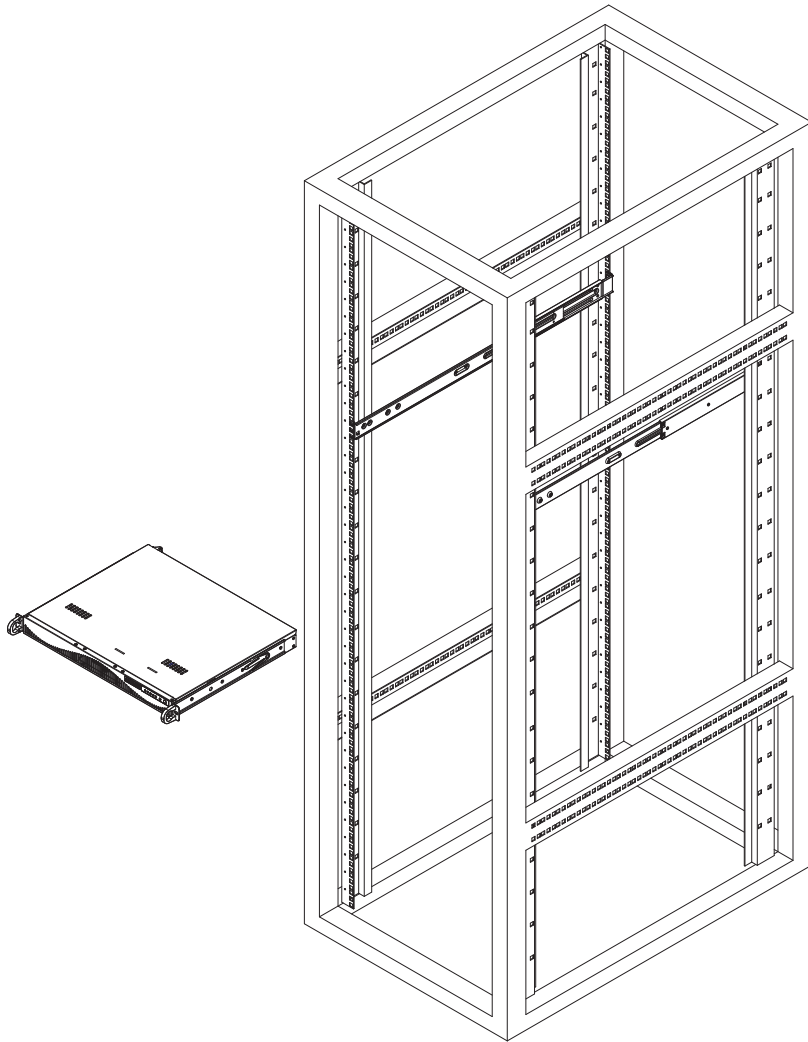

4. Finish by inserting and tightening the thumbscrews that hold the front of the server to the rack.

#### ***Installing the Server into a Telco Rack***

If you are installing the SuperServer 6016T-MR into a Telco type rack, follow the directions given on the previous pages for rack installation. The only difference in the installation procedure will be the positioning of the rack brackets to the rack. They should be spaced apart just enough to accommodate the width of the telco rack.

Figure 2-4. Installing the Server into a Telco Rack

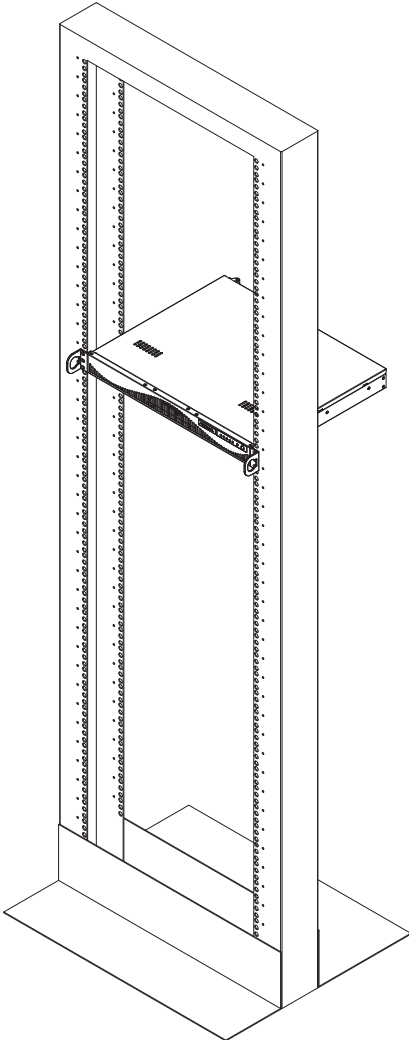

## 2-5 Checking the Serverboard Setup

After you install the server in the rack, you will need to open the unit to make sure the serverboard is properly installed and all the connections have been made.

### *Removing the Chassis Cover*

1. Release the retention screws that secure the unit to the rack.
2. Grasp the two handles on either side and pull the unit straight out until it locks (you will hear a "click").
3. Remove the screws from the chassis cover (see Figure 2-5).
4. Release the top cover by pushing it away from you until it stops. You can then lift the top cover from the chassis to gain full access to the inside of the server

### *Checking the Components*

1. You may have processors already installed into the serverboard. Each processor should have its own heatsink attached. See Chapter 5 for instructions on processor installation.
2. The 6016T-MR server may have come with system memory already installed. Make sure all DIMMs are fully seated in their slots. For details on adding system memory, refer to Chapter 5.
3. If desired, you can install an add-on card to the system. See Chapter 5 for details on installing a PCI add-on card.
4. Make sure all power and data cables are properly connected and not blocking the airflow. See Chapter 5 for details on cable connections. Also, check that the air shroud is properly installed.

## 2-6 Checking the Drive Bay Setup

### *Checking the Drives*

1. For servicing the SATA and DVD-ROM drives, you will need to remove the top chassis cover. The SATA disk drive is located at the front of the chassis' interior.
2. Refer to Chapter 6 if you need to reinstall a DVD-ROM drive to the system.
3. Depending upon your system's configuration, your system may have a SATA hard drive already installed. If you need to install a SATA hard drive, please refer to the appropriate section in Chapter 6.

### *Checking the Airflow*

1. Airflow is provided by sets of 4-cm counter-rotating fans. The system component layout was carefully designed to promote sufficient airflow through the small 1U rackmount space.
2. Also note that all power and data cables have been routed in such a way that they do not block the airflow generated by the fan.

### *Providing Power*

1. The last thing you must do is to provide input power to the system. Plug the power cord from the power supply unit into a high-quality power strip that offers protection from electrical noise and power surges. It is recommended that you use an uninterruptible power supply (UPS).
2. Finish by pushing the power button on the control panel to power up the system.

Figure 2-5. Accessing the Inside of the Server

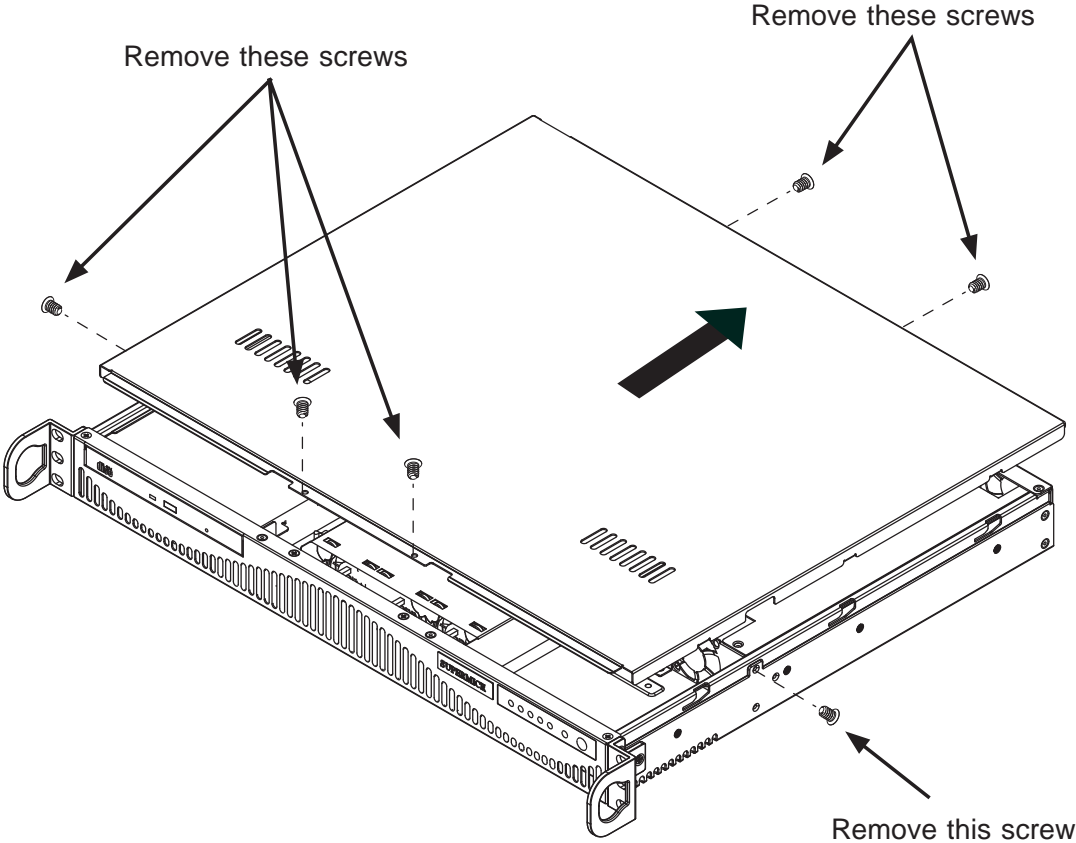

**Notes**

# Chapter 3

## System Interface

### 3-1 Overview

There are several LEDs on the control panel to keep you constantly informed of the overall status of the system as well as the activity and health of specific components. There are also two buttons on the chassis control panel. This chapter explains the meanings of all LED indicators and the appropriate response you may need to take.

### 3-2 Control Panel Buttons

There are two push buttons located on the front of the chassis: a reset button and a power on/off button.



#### Reset

The reset switch reboots the system.

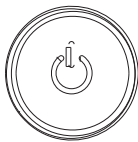

#### Power

This is the main power switch, which is used to apply or turn off the main system power. Turning off system power with this button removes the main power but keeps standby power supplied to the system.

### 3-3 Control Panel LEDs

The control panel located on the front of the SC512F-520B chassis has five LEDs. These LEDs provide you with critical information related to different parts of the system. This section explains what each LED indicates when illuminated and any corrective action you may need to take.



#### Overheat/Fan Fail

When this LED flashes it indicates a fan failure. When on continuously (on and not flashing) it indicates an overheat condition, which may be caused by cables obstructing the airflow in the system or the ambient room temperature being too warm. Check the routing of the cables and make sure all fans are present and operating normally. You should also check to make sure that the chassis covers are installed. Finally, verify that the heatsinks are installed properly (see Chapter 5). This LED will remain flashing or on as long as the overheat condition exists.



#### NIC2

Indicates network activity on LAN2 when flashing.



#### NIC1

Indicates network activity on LAN1 when flashing.



### **HDD**

Channel activity for HDDs. This light indicates IDE drive activity when flashing.



### **Power**

Indicates power is being supplied to the system's power supply units. This LED should normally be illuminated when the system is operating.

## Notes

# Chapter 4

## System Safety

### 4-1 Electrical Safety Precautions



Basic electrical safety precautions should be followed to protect yourself from harm and the SuperServer 6016T-MR from damage:

- Be aware of the locations of the power on/off switch on the chassis as well as the room's emergency power-off switch, disconnection switch or electrical outlet. If an electrical accident occurs, you can then quickly remove power from the system.
- Do not work alone when working with high voltage components.
- Power should always be disconnected from the system when removing or installing main system components, such as the serverboard, memory modules and floppy drive. When disconnecting power, you should first power down the system with the operating system first and then unplug the power cords of all the power supply units in the system.
- When working around exposed electrical circuits, another person who is familiar with the power-off controls should be nearby to switch off the power if necessary.
- Use only one hand when working with powered-on electrical equipment. This is to avoid making a complete circuit, which will cause electrical shock. Use extreme caution when using metal tools, which can easily damage any electrical components or circuit boards they come into contact with.
- Do not use mats designed to decrease static electrical discharge as protection from electrical shock. Instead, use rubber mats that have been specifically designed as electrical insulators.
- The power supply power cords must include a grounding plug and must be plugged into grounded electrical outlets.

- This product may be connected to an IT power system. In all cases, make sure that the unit is also reliably connected to Earth (ground).
- Serverboard Battery: **CAUTION** - There is a danger of explosion if the onboard battery is installed upside down, which will reverse its polarities (see Figure 4-1). This battery must be replaced only with the same or an equivalent type recommended by the manufacturer (CR2032). Dispose of used batteries according to the manufacturer's instructions.
- DVD-ROM Laser: **CAUTION** - this server may have come equipped with a DVD-ROM drive. To prevent direct exposure to the laser beam and hazardous radiation exposure, do not open the enclosure or use the unit in any unconventional way.
- Mainboard replaceable soldered-in fuses: Self-resetting PTC (Positive Temperature Coefficient) fuses on the mainboard must be replaced by trained service technicians only. The new fuse must be the same or equivalent as the one replaced. Contact technical support for details and support.

## 4-2 General Safety Precautions



Follow these rules to ensure general safety:

- Keep the area around the 6016T-MR clean and free of clutter.
- The 6016T-MR weighs approximately 18 lbs (8.2 kg) when fully loaded. When lifting the system, two people at either end should lift slowly with their feet spread out to distribute the weight. Always keep your back straight and lift with your legs.
- Place the chassis top cover and any system components that have been removed away from the system or on a table so that they won't accidentally be stepped on.
- While working on the system, do not wear loose clothing such as neckties and unbuttoned shirt sleeves, which can come into contact with electrical circuits or be pulled into a cooling fan.

- Remove any jewelry or metal objects from your body, which are excellent metal conductors that can create short circuits and harm you if they come into contact with printed circuit boards or areas where power is present.
- After accessing the inside of the system, close the system back up and secure it to the rack unit with the retention screws after ensuring that all connections have been made.

### 4-3 ESD Precautions



Electrostatic Discharge (ESD) is generated by two objects with different electrical charges coming into contact with each other. An electrical discharge is created to neutralize this difference, which can damage electronic components and printed circuit boards. The following measures are generally sufficient to neutralize this difference before contact is made to protect your equipment from ESD:

- Use a grounded wrist strap designed to prevent static discharge.
- Keep all components and printed circuit boards (PCBs) in their antistatic bags until ready for use.
- Touch a grounded metal object before removing the board from the antistatic bag.
- Do not let components or PCBs come into contact with your clothing, which may retain a charge even if you are wearing a wrist strap.
- Handle a board by its edges only; do not touch its components, peripheral chips, memory modules or contacts.
- When handling chips or modules, avoid touching their pins.
- Put the serverboard and peripherals back into their antistatic bags when not in use.
- For grounding purposes, make sure your computer chassis provides excellent conductivity between the power supply, the case, the mounting fasteners and the serverboard.

## 4-4 Operating Precautions



Care must be taken to assure that the chassis cover is in place when the 6016T-MR is operating to assure proper cooling. Out of warranty damage to the system can occur if this practice is not strictly followed.

**Figure 4-1. Installing the Onboard Battery**

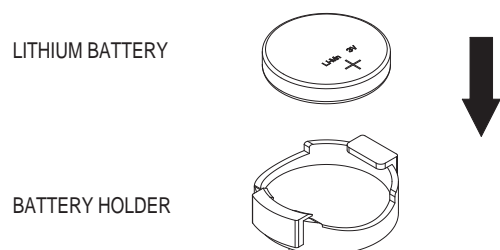

Please handle used batteries carefully. Do not damage the battery in any way; a damaged battery may release hazardous materials into the environment. Do not discard a used battery in the garbage or a public landfill. Please comply with the regulations set up by your local hazardous waste management agency to dispose of your used battery properly.

## Chapter 5

### Advanced Serverboard Setup

This chapter covers the steps required to install the X8DTL-i serverboard into the SC512F-520B chassis, connect the data and power cables and install add-on cards. All serverboard jumpers and connections are also described. A layout and quick reference chart are included in this chapter for your reference. Remember to completely close the chassis when you have finished working with the serverboard to better cool and protect the system.

#### 5-1 Handling the Serverboard

Electrostatic Discharge (ESD) can damage electronic components. To prevent damage to any printed circuit boards (PCBs), it is important to handle them very carefully (see previous chapter). To prevent the X8DTL-i serverboard from bending, keep one hand under the center of the board to support it when handling. The following measures are generally sufficient to protect your equipment from electric static discharge.

##### Precautions

- Use a grounded wrist strap designed to prevent electrostatic discharge (ESD).
- Touch a grounded metal object before removing any board from its antistatic bag.
- Handle a board by its edges only; do not touch its components, peripheral chips, memory modules or gold contacts.
- When handling chips or modules, avoid touching their pins.
- Put the serverboard, add-on cards and peripherals back into their antistatic bags when not in use.
- For grounding purposes, make sure your computer chassis provides excellent conductivity between the power supply, the case, the mounting fasteners and the serverboard.

## Unpacking

The serverboard is shipped in antistatic packaging to avoid electrical static discharge. When unpacking the board, make sure the person handling it is static protected.

## 5-2 Serverboard Installation

This section explains the first step of physically mounting the X8DTL-i into the SC512F-520B chassis. Following the steps in the order given will eliminate the most common problems encountered in such an installation. To remove the serverboard, follow the procedure in reverse order.

### *Installing to the Chassis*

1. Remove the screws from the rear lip of the chassis cover (see Figure 2-5).
2. Release the top cover by pushing it away from you until it stops. You can then lift the top cover from the chassis to gain full access to the inside of the server
3. Make sure that the I/O ports on the serverboard align properly with their respective holes in the I/O shield at the back of the chassis.
4. Carefully mount the serverboard to the serverboard tray by aligning the board holes with the raised metal standoffs that are visible in the chassis.
5. Insert screws into all the mounting holes on your serverboard that line up with the standoffs and tighten until snug (if you screw them in too tight, you might strip the threads).

**Note:** Metal screws provide an electrical contact to the serverboard ground to provide a continuous ground for the system.

**Warning:** To avoid damaging the serverboard and its components, do not apply any force greater than 8 lbs. per square inch when installing a screw into a mounting hole.

## 5-3 Connecting Cables

Now that the serverboard is installed, the next step is to connect the cables to the board. These include the data cables for the peripherals and control panel and the power cables.

### Connecting Data Cables

The cables used to transfer data from the peripheral devices have been carefully routed to prevent them from blocking the flow of cooling air that moves through the system from front to back. If you need to disconnect any of these cables, you should take care to keep them routed as they were originally after reconnecting them (make sure the red wires connect to the pin 1 locations).

The following data cables (with their locations noted) should be connected. (See the layout on page 5-9 for connector locations.)

- DVD-ROM cable (I-SATA4)
- SATA drive cables (I-SATA0)
- Control Panel cable (JF1)

### Connecting Power Cables

The X8DTL-i has a 24-pin primary power supply connector (JPW1) for connection to the ATX power supply. In addition, there are two 8-pin processor power connectors (JPW2/JPW3) that also must be connected to your power supply. See Section 5-9 for power connector pin definitions.

### Connecting the Control Panel

JF1 contains header pins for various front control panel connectors. See Figure 5-1 for the pin locations of the various front control panel buttons and LED indicators. All JF1 wires have been bundled into a single ribbon cable to simplify this connection. Make sure the red wire plugs into pin 1 as marked on the board. The other end connects to the Control Panel PCB board, located just behind the system status LEDs on the chassis.

**Figure 5-1. Control Panel Header Pins**

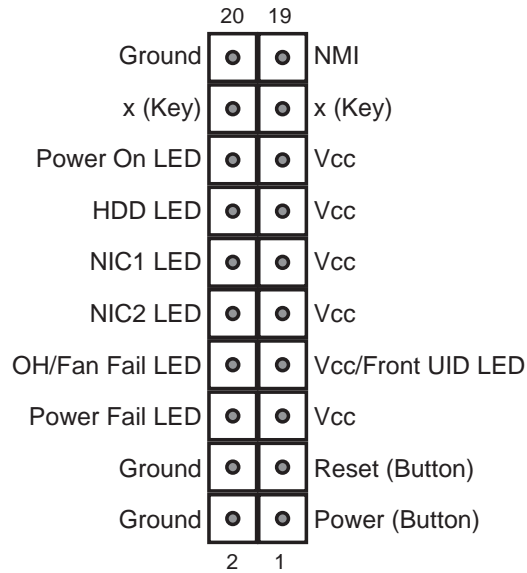

## 5-4 Rear I/O Ports

The I/O ports are color coded in conformance with the PC 99 specification. See Figure 5-2 below for the colors and locations of the various I/O ports.

**Figure 5-2. Rear I/O Ports**

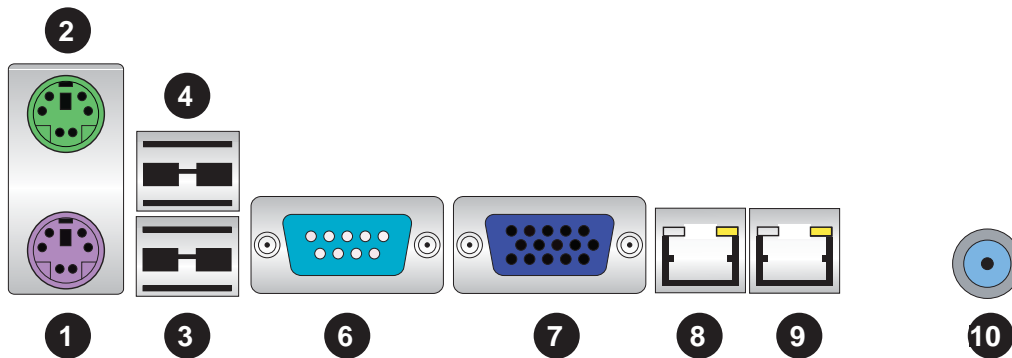

Rear I/O Ports	
1. Keyboard	6. COM1
2. PS/2 Mouse	7. VGA Port
3. USB0	8. LAN1
4. USB1	9. LAN2
5. IPMI LAN	10. UID Button

**Note:** The COM2 port is a header on the serverboard, located near the onboard speaker. COM2 should be connected to the COM port at the front of the chassis.

## 5-5 Installing the Processor and Heatsink



When handling the processor package, avoid placing direct pressure on the label area of the fan.

### Notes:

- Always connect the power cord last and always remove it before adding, removing or changing any hardware components. Make sure that you install the processor into the CPU socket before you install the CPU heatsink.
- If you buy a CPU separately, make sure that you use an Intel-certified multi-directional heatsink only.
- Make sure to install the serverboard into the chassis before you install the CPU heatsinks.
- When receiving a serverboard without a processor pre-installed, make sure that the plastic CPU socket cap is in place and none of the socket pins are bent; otherwise, contact your retailer immediately.
- Refer to the Supermicro web site for updates on CPU support.

### Installing an LGA1366 Processor

1. Press the socket clip to release the load plate, which covers the CPU socket, from its locked position.
2. Gently lift the socket clip to open the load plate.
3. Hold the plastic cap at its north and south center edges to remove it from the CPU socket.

**Note:** The photos on this page and succeeding pages are for illustration purposes only. They do not necessarily reflect the exact product(s) described in this manual.

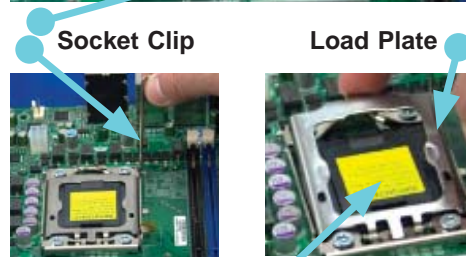

Holding the north & south edges

1. After removing the plastic cap, use your thumb and the index finger to hold the CPU at the north and south center edges.
2. Align the CPU key (the semi-circle cutout) with the socket key (the notch below the gold color dot on the side of the socket).
3. Once the CPU and the socket are aligned, carefully lower the CPU straight down into the socket. Do not rub the CPU against the surface of the socket or its pins to avoid damaging the CPU or the socket.
4. With the CPU in the socket, inspect the four corners of the CPU to make sure that it sits level and is properly installed.
5. Once the CPU is securely seated in the socket, lower the CPU load plate to the socket.
6. Use your thumb to gently push the socket clip down to the clip lock.

**Important!** Please save the plastic cap. The serverboard must be shipped with the plastic cap properly installed to protect the CPU socket pins. Shipment without the plastic cap properly installed may cause damage to the socket pins.

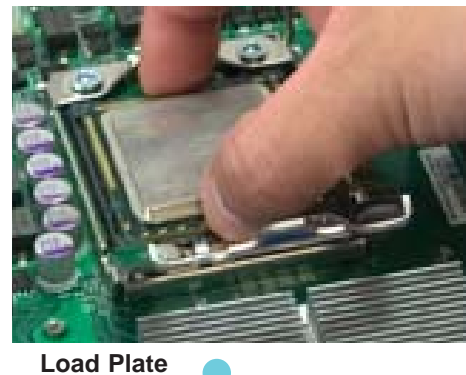
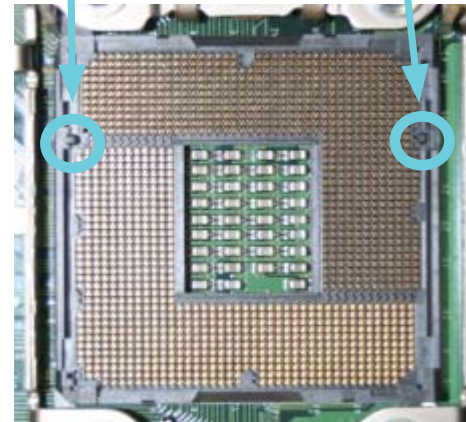
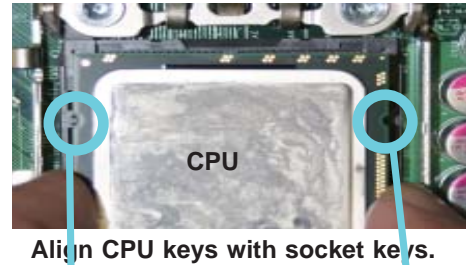
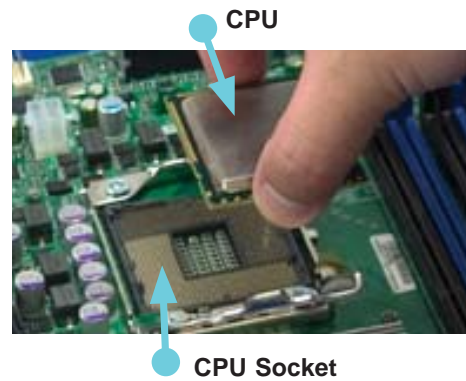

## Installing a Passive CPU Heatsink

**Notes:** The serverboard comes with a heatsink bracket pre-installed on the reverse side of the board. Do not apply any thermal grease to the heatsink or the CPU die; the required amount has already been applied.

1. Place the heatsink on top of the CPU so that the four mounting holes are aligned with those on the retention mechanism.
2. Install two diagonal screws (i.e. the #1 and the #2 screws) and tighten them until just snug (do not fully tighten the screws to avoid damaging the CPU.)
3. Repeat step 2 with the #3 and #4 screws. Make sure all screws are snug.

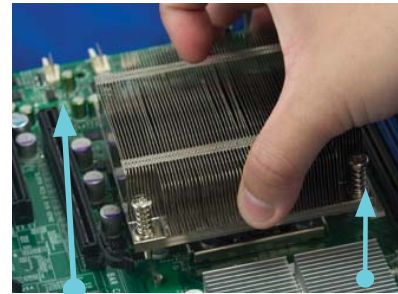
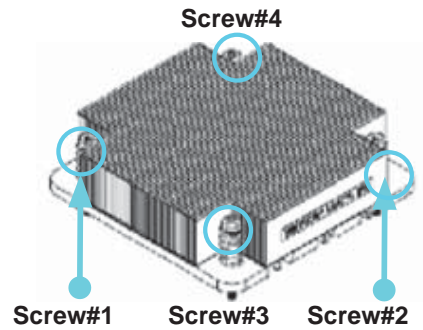

Install Screw#1

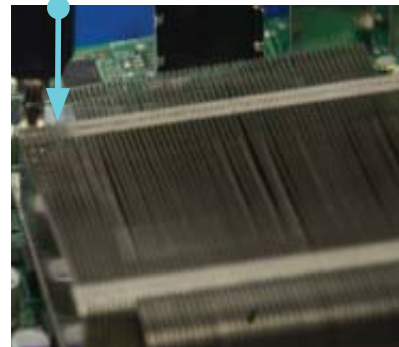

Screw#1

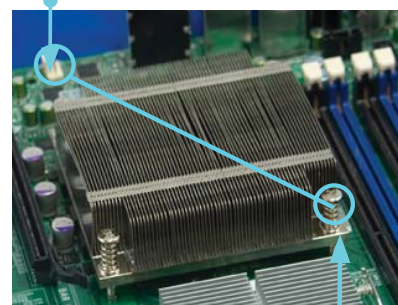

Install Screw#2

**Note:** two different heatsinks are used in the 6016T-MR. SNK-P0037P is for CPU1 and SNK-P0041 is for CPU2. See the serverboard layout page for the locations of CPU1 and CPU2.

## Removing the Heatsink



**Warning:** We do not recommend that the CPU or the heatsink be removed. However, if you do need to remove the heatsink, please follow the instructions below prevent damage to the CPU or other components.

1. Power down the system and unplug the power cord from the power supply.
2. Disconnect the heatsink fan's wires from the fan header.
3. Using a screwdriver, loosen and remove the heatsink screws from the serverboard in the sequence as show in the previous section (#1 and #2 followed by #3 and #4).
4. Hold the heatsink as shown in the picture on the right and gently wiggle it to loosen it from the CPU. (Do not use excessive force when doing this.)
5. Once the heatsink is loose, remove it from the CPU socket.
6. To reinstall the heatsink, clean the surface of the CPU and the heatsink to get rid of the old thermal grease. Reapply the proper amount of thermal grease to the surface of the CPU then reinstall the heatsink.

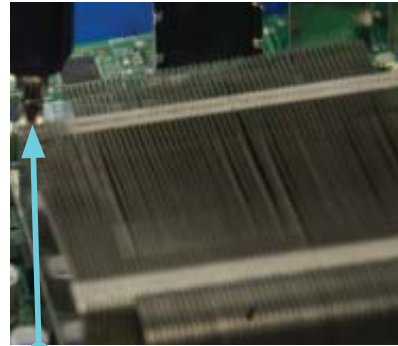

Screw#1

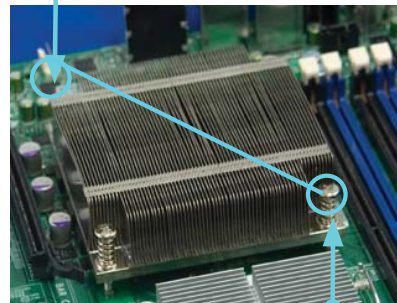

Screw#2



## 5-6 Installing Memory Modules

**Note:** Check the Supermicro web site for recommended memory modules.

### CAUTION

Exercise extreme care when installing or removing DIMM modules to prevent any possible damage.

### Installing & Removing DIMMs

1. Insert the desired number of DIMMs into the memory slots, starting with DIMM #1A. For best performance, please use the memory modules of the same type and same speed in the same bank. See the DIMM Installation Chart on the following page.
2. Press down the release tabs on the ends of a memory slot. Insert each DIMM module vertically into its slot. Pay attention to the notch along the bottom of the module to prevent inserting the DIMM module incorrectly.
3. Gently press down on the DIMM module until it snaps into place in the slot. Repeat for all modules.
4. Reverse the steps above to remove the DIMM modules from the serverboard.

Press the release tabs

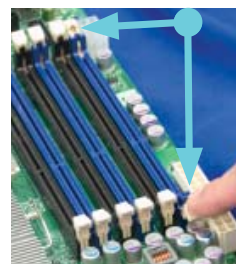

Insert & press a DIMM into the slot

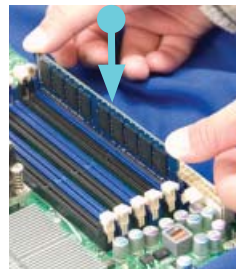
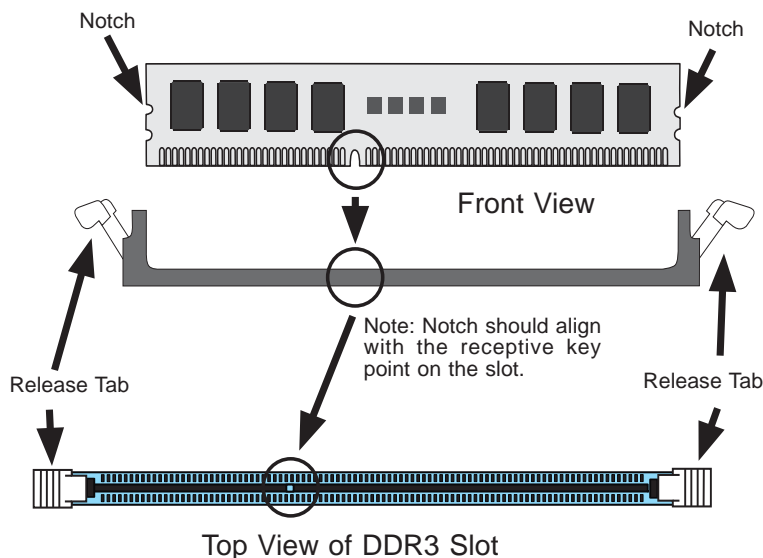

Figure 5-3. DIMM Installation

**To Install:** Insert module vertically and press down until it snaps into place. Pay attention to the alignment notch at the bottom.

**To Remove:** Use your thumbs to gently push the release tabs near both ends of the module. This should release it from the slot.



### Memory Support

The X8DTL-i supports up to 48 GB of registered ECC or 24 GB of unbuffered-DDR3-1333/1066/800 MHz registered ECC SDRAM in 6 DIMM slots.

### Populating DIMMs

Follow the tables below when installing memory.

Populating DIMMs for Optimal Performance For One CPU (CPU1) Installed (Populate the CPU1 DIMM slots)			
	Branch 0	Branch 1	Branch 2
3 DIMMs	P1-1A	P1-2A	P1-3A

Populating DIMMs for Optimal Performance For One CPU (CPU2) Installed (Populate the CPU2 DIMM slots)			
	Branch 0	Branch 1	Branch 2
3 DIMMs	P2-1A	P2-2A	P2-3A

Populating DIMMs for Optimal Performance For Two CPUs Installed						
	CPU1 DIMMs			CPU2 DIMMs		
	Branch 0	Branch 1	Branch 2	Branch 0	Branch 1	Branch 2
6 DIMMs	P1-1A	P1-2A	P1-3A	P2-1A	P2-2A	P2-3A

Memory Population Table				
DIMM Slots per Channel	DIMMs Populated per Channel	DIMM Type (Reg.= Registered)	Speeds (in MHz)	Ranks per DIMM (any combination; SR=Single Rank, DR=Dual Rank, QR=Quad Rank)
1	1	Reg. DDR3 ECC	800,1066,1333	SR, DR
1	1	Reg. DDR3 ECC	800,1066,	QR

**Notes:** Due to OS limitations, some operating systems may not show more than 4 GB of memory.

Due to memory allocation to system devices, the amount of memory that remains available for operational use will be reduced when 4 GB of RAM is used. The reduction in memory availability is disproportional. (See the following table.)

Possible System Memory Allocation & Availability		
System Device	Size	Physical Memory Remaining (Available) (4 GB Total System Memory)
Firmware Hub flash memory (System BIOS)	1 MB	3.99
Local APIC	4 KB	3.99
Area Reserved for the chipset	2 MB	3.99
I/O APIC (4 Kbytes)	4 KB	3.99
PCI Enumeration Area 1	256 MB	3.76
PCI Express (256 MB)	256 MB	3.51
PCI Enumeration Area 2 (if needed) -Aligned on 256-MB boundary-	512 MB	3.01
VGA Memory	16 MB	2.85
TSEG	1 MB	2.84
Memory available to OS and other applications		2.84

## 5-7 Adding PCI Cards

The 6016T-MR includes a CSE-RR1U-E8 riser card. This riser fits into a PCI slot to support a full-height, half-length PCI Express expansion card. (The riser card provides a PCI-E x8 signal.)

### ***PCI Card Installation***

When installing a PCI add-on card, make sure you install it into a slot that supports the speed of the card.

1. Swing out the release tab on the PCI slot shield.
2. Insert the PCI card into the riser card, pushing down with your thumbs evenly on both sides of the card.
3. Finish by pushing the release tab back to its original (locked) position.

## 5-8 Serverboard Details

### Serverboard Layout

Figure 5-4. X8DTL-i Layout

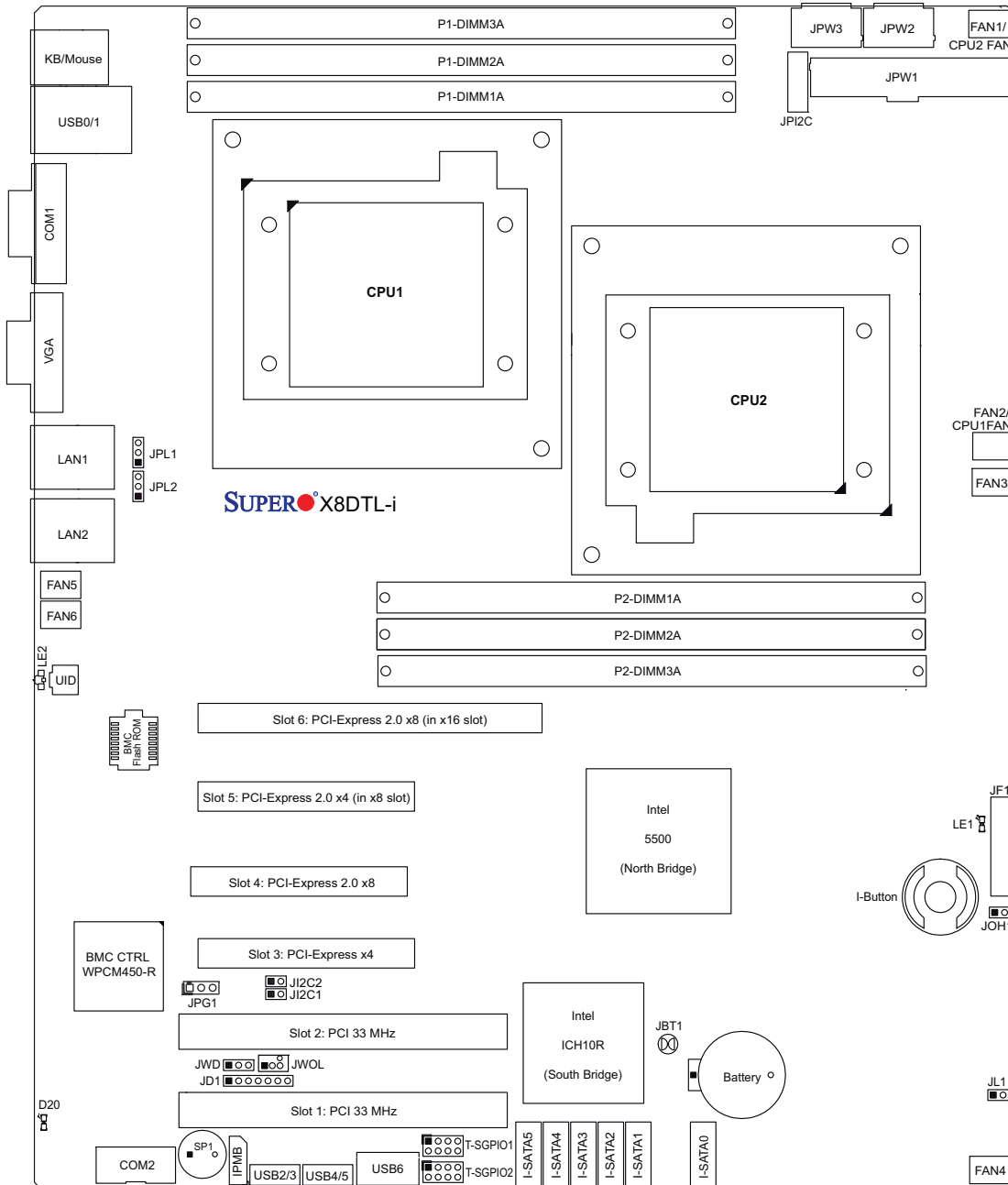

Jumpers not indicated are for test purposes only.

A square contact pad indicates the location of pin 1.

## X8DTL-i Quick Reference

<b>Jumper</b>	<b>Description</b>	<b>Default Setting</b>
JBT1	CMOS Clear	Open (Normal)
JI <sup>2</sup> C1/JI <sup>2</sup> C2	SMB to PCI/PCI-E Slots	Open/Open (Disabled)
JPG1	VGA Enable/Disable	Pins 1-2 (Enabled)
JPL1/JPL2	LAN1/2 Enable	Pins 1-2 (Enabled)
JWD	Watch Dog	Pins 1-2 (Reset)

<b>Connector</b>	<b>Description</b>
COM1/COM2	COM1/COM2 Serial Port/Header
FAN 1-6	System/CPU Fan Headers (Fans 1~2: CPU Fans)
I-Button	I-Button for RAID data storage
IPMB	I <sup>2</sup> C Header for IPMI Card
JPI <sup>2</sup> C	Power Supply SMBbus I <sup>2</sup> C Header
JD1	PWR LED/Speaker Header (Pins 4~7: Speaker)
JF1	Front Panel Connector
JL1	Chassis Intrusion Header
JOH1	Overheat LED Header
JPI2C	Power Supply SMBus I <sup>2</sup> C Header
JPW1, JPW2/JPW3	24-pin ATX PWR, 8-pin Secondary PWR
JWOL	Wake-On-LAN Header
LAN1/2	LAN (RJ45) Ports
I-SATA0 ~ I-SATA5	(Intel South Bridge) SATA Ports
T-SGPIO-1/T-SGPIO-2	Serial General Purpose I/O Headers for SATA
USB 0/1, 2,3, 4/5, 6	Universal Serial Bus (USB) Ports
UID	Rear Unit Identify Switch
VGA	VGA Connector

<b>LED</b>	<b>Description</b>
D20	BMC Heartbeat LED Indicator
LE1	Onboard Standby LED Indicator
LE2	Rear UID LED

## 5-9 Connector Definitions

### ATX Power Connector

The primary power supply connector (JPW1) on the X8DTL-i meets the SSI EPS 12V specification. Refer to the table on the right for the pin definitions of the ATX 24-pin power connector. You must also connect the 8-pin processor power connectors (JPW2/JPW3) to your power supply. Refer to the table below right for the main power connector.

ATX Power 24-pin Connector Pin Definitions			
Pin#	Definition	Pin #	Definition
13	+3.3V	1	+3.3V
14	-12V	2	+3.3V
15	COM	3	COM
16	PS_ON	4	+5V
17	COM	5	COM
18	COM	6	+5V
19	COM	7	COM
20	Res (NC)	8	PWR_OK
21	+5V	9	5VSB
22	+5V	10	+12V
23	+5V	11	+12V
24	COM	12	+3.3V

### Processor Power Connector

In addition to JPW1, the 12V 8-pin processor power connectors at JPW2 and JPW3 must be connected to your serverboard. Failure in doing so will void the manufacturer warranty on your power supply and serverboard. See the table on the right for pin definitions.

Processor Power Connector Pin Definitions	
Pins	Definition
1 through 4	Ground
5 through 8	+12V

#### Required Connection

### PW\_ON Connector

The PW\_ON connector is on pins 1 and 2 of JF1. This header should be connected to the chassis power button. See the table on the right for pin definitions.

Power Button Pin Definitions	
Pin#	Definition
1	PW_ON
2	Ground

### Reset Connector

The reset connector is located on pins 3 and 4 of JF1 and attaches to the reset switch on the computer chassis. See the table on the right for pin definitions.

Reset Button Pin Definitions	
Pin#	Definition
3	Reset
4	Ground

**Power Fail LED**

The Power Fail LED connection is located on pins 5 and 6 of JF1. Refer to the table on the right for pin definitions.

PWR Fail LED Pin Definitions	
Pin#	Definition
5	Vcc
6	Ground

**Overheat LED (OH)**

Connect an LED to the OH connection on pins 7 and 8 of JF1 to provide advanced warning of chassis overheating. Refer to the table on the right for pin definitions.

OH/Fan Fail LED Pin Definitions	
Pin#	Definition
7	Vcc
8	Ground

**NIC2 (LAN2) LED**

The LED connections for LAN2 are on pins 9 and 10 of JF1. Attach LAN LED cables to display network activity. See the table on the right for pin definitions.

NIC2 LED Pin Definitions	
Pin#	Definition
9	Vcc
10	Ground

**NIC1 (LAN1) LED**

The LED connections for LAN1 are on pins 11 and 12 of JF1. Attach LAN LED cables to display network activity. See the table on the right for pin definitions.

NIC1 LED Pin Definitions	
Pin#	Definition
11	Vcc
12	Ground

**HDD LED**

The HDD LED connection is located on pins 13 and 14 of JF1. Attach the hard drive LED cable here to display disk activity (for any hard drives on the system, including Serial ATA and IDE). See the table on the right for pin definitions.

HDD LED Pin Definitions	
Pin#	Definition
13	Vcc
14	HD Active

### Power On LED

The Power On LED connector is located on pins 15 and 16 of JF1. This connection is used to provide LED indication of power being supplied to the system. See the table on the right for pin definitions.

Power LED Pin Definitions	
Pin#	Definition
15	5V Stby
16	Control

### NMI Button

The non-maskable interrupt button header is located on pins 19 and 20 of JF1. Refer to the table on the right for pin definitions.

NMI Button Pin Definitions	
Pin#	Definition
19	Control
20	Ground

### Fan Headers

There are six fan headers on the X8DTL-i. All are 4-pin fans but are backward compatible with traditional 3-pin fans. FAN1 is for the CPU1 heatsink and FAN2 is for the CPU2 heatsink. See the table on the right for pin definitions.

Fan Header Pin Definitions	
Pin#	Definition
1	Ground (Black)
2	+12V (Red)
3	Tachometer
4	PWM Control

### ATX PS/2 Keyboard and PS/2 Mouse Ports

The ATX PS/2 keyboard and the PS/2 mouse are located on the rear IO panel. The mouse port is above the keyboard port. See the table on the right for pin definitions.

PS/2 Keyboard and Mouse Port Pin Definitions	
Pin#	Definition
1	Data
2	NC
3	Ground
4	VCC
5	Clock
6	NC

### Chassis Intrusion

The Chassis Intrusion header is designated JL1. See the board layout for the location of JL1 and the table on the right for pin definitions.

Chassis Intrusion Pin Definitions	
Pin#	Definition
1	Intrusion Input
2	Ground

### Universal Serial Bus (USB)

There are two Universal Serial Bus ports located on the I/O panel and five additional USB headers located on the serverboard. The headers, labeled USB2/3 and USB4/5, can be used to provide front side USB access (cables not included). USB 6 is an A Type. See the tables on the right for pin definitions.

USB Ports Pin Definitions (USB0/1/6)	
Pin#	Definitions
1	+5V
2	PO-
3	PO+
4	Ground
5	N/A

USB Headers Pin Definitions (USB2/3, USB4/5)			
USB2/4		USB3/5	
Pin #	Definition	Pin #	Definition
1	+5V	1	+5V
2	PO-	2	PO-
3	PO+	3	PO+
4	Ground	4	Ground
5	Key	5	No connection

### Serial Ports

Two serial ports are included on the serverboard: COM1 is a port located beside the USB ports and COM2 is a header located on the corner of the board near the SIMLC slot. See the table on the right for pin definitions.

Serial Port Pin Definitions			
Pin #	Definition	Pin #	Definition
1	DCD	6	DSR
2	RXD	7	RTS
3	TXD	8	CTS
4	DTR	9	RI
5	Ground	10	NC

**Note:** Pin 10 is included on the header but not on the port. NC indicates no connection.

### Wake-On-LAN

The Wake-On-LAN header is designated JWOL on the serverboard. See the table on the right for pin definitions. You must enable the LAN Wake-Up setting in BIOS to use this function. (You must also have a LAN card with a Wake-On-LAN connector and cable to use this feature.)

Wake-On-LAN Pin Definitions	
Pin#	Definition
1	+5V Standby
2	Ground
3	Wake-up

### Onboard Speaker (SP1)

The onboard speaker provides audible indications for various beep codes. See the table on the right for pin definitions.

Internal Buzzer Pin Definition		
Pin#	Definitions	
Pin 1	Pos. (+)	Beep In
Pin 2	Neg. (-)	Alarm Speaker

### Power LED/Speaker

On the JD1 header, pins 1-3 are for a power LED and pins 4-7 are for the speaker. See the table on the right for speaker pin definitions.

PWR LED Connector Pin Definitions	
Pin Setting	Definition
Pin 1	Anode (+)
Pin2	Cathode (-)
Pin3	NA

**Note:** The speaker connector pins are for use with an external speaker. If you wish to use the onboard speaker, you should close pins 6-7 with a jumper.

Speaker Connector Pin Definitions	
Pin Setting	Definition
Pins 4-7	External Speaker
Pins 6-7	Internal Speaker

### SGPIO Headers

Two SGPIO (Serial General Purpose Input/Output) headers are included on the serverboard. These headers are used to communicate with the System Monitoring chip on the backplane and provide a serial interface to the SATA ports. See the table on the right for pin definitions.

SGPIO Headers Pin Definitions			
Pin#	Definition	Pin	Definition
1	NC	2	NC
3	Ground	4	DATA Out
5	Load	6	Ground
7	Clock	8	NC

**Note:** NC indicates no connection.

### I-Button

An onboard I-Button, located next to USB Ports 2~3, is an 1-wire computer chip enclosed in a durable stainless steel can. The I-Button stores instructions, provides electronic interface and allows the HostRAID to operate with Mega-RAID firmware.



### LAN1/2 (Ethernet Ports)

Two gigabit Ethernet ports (designated LAN1 and LAN2) are located beside the VGA port on the I/O back-plane. These ports accept RJ45 type cables.



### Power SMB (I<sup>2</sup>C) Header

The Power System Management Bus (I<sup>2</sup>C) header (JPI<sup>2</sup>C) monitors power supply, fan and system temperatures. See the table on the right for pin definitions.

PWR SMB Pin Definitions	
Pin#	Definition
1	Clock
2	Data
3	PWR Fail
4	Ground
5	+3.3V

### IPMB

IPMB is a System Management Bus header for IPMI 2.0. Connect the appropriate cable here to use the IPMB I<sup>2</sup>C connection on your system.

SMB Header Pin Definitions	
Pin#	Definition
1	Data
2	Ground
3	Clock
4	No Connection

### Overheat LED/Fan Fail (JOH1)

The JOH1 header connects to an LED indicator to provide warnings of chassis overheating or fan failure. This LED will blink when a fan failure occurs. Refer to the table on right for pin definitions.

Overheat LED Pin Definitions	
Pin#	Definition
1	5vDC
2	OH Active

OH/Fan Fail LED Pin Definitions	
State	Message
Solid	Overheat
Blinking	Fan Fail

### Unit Identifier Button

A Unit Identifier (UID) button is located next to the Fan 6 header. When you push the UID button, both Rear UID and Front Panel UID Indicators will illuminate. Push it again to turn off both Indicators. These UID Indicators provide easy identification of a system unit that may be in need of service.

## 5-10 Jumper Settings

### Explanation of Jumpers

To modify the operation of the serverboard, jumpers can be used to choose between optional settings. Jumpers create shorts between two pins to change the function of the connector. Pin 1 is identified with a square solder pad on the printed circuit board. See the serverboard layout pages for jumper locations.

**Note:** On a two-pin jumper, "Closed" means the jumper is on both pins and "Open" means the jumper is either on only one pin or completely removed.

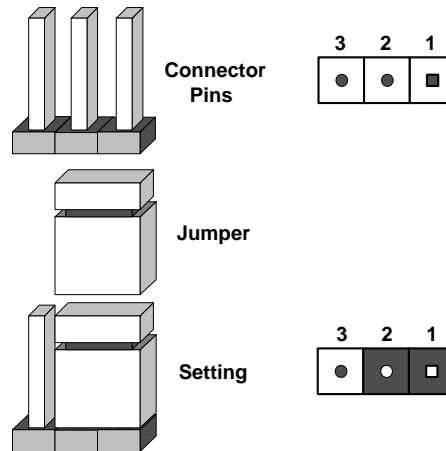

### CMOS Clear

JBT1 is used to clear CMOS (which will also clear any passwords). Instead of pins, this jumper consists of contact pads to prevent accidentally clearing the contents of CMOS. To clear CMOS,

1. First power down the system and unplug the power cord(s).
2. With the power disconnected, short the CMOS pads with a metal object such as a small screwdriver.
3. Remove the screwdriver (or shorting device).
4. Reconnect the power cord(s) and power on the system

**Note:** Do not use the PW ON connector to clear CMOS.

### VGA Enable/Disable

JPG1 allows you to enable or disable the VGA port. The default position is on pins 1 and 2 to enable VGA. See the table on the right for jumper settings.

VGA Enable/Disable Jumper Settings	
Jumper Setting	Definition
Pins 1-2	Enabled
Pins 2-3	Disabled

### LAN1/LAN2 Enable/Disable

Change the setting of jumper JPL1 to enable or disable the LAN1 port and JPL2 to enable or disable the LAN2 port on the serverboard. See the table on the right for jumper settings. The default setting is enabled.

LAN1/2 Enable/Disable Jumper Settings	
Jumper Setting	Definition
Pins 1-2	Enabled
Pins 2-3	Disabled

### Watch Dog

JWD enables the Watch Dog function, a system monitor that takes action when a software application freezes the system. Jumping pins 1-2 will have WD reboot the system if a program freezes. Jumping pins 2-3 will generate a non-maskable interrupt for the program that has frozen. See the table on the right for jumper settings. Watch Dog must also be enabled in BIOS.

Watch Dog Jumper Settings	
Jumper Setting	Definition
Pins 1-2	Reset
Pins 2-3	NMI
Open	Disabled

**Note:** when Watch Dog is enabled, the user must write their own application software to disable the Watch Dog Timer.

### I<sup>2</sup>C Bus to PCI/PCI-Exp. Slots

Jumpers JI<sup>2</sup>C1 and JI<sup>2</sup>C2 allow you to connect the System Management Bus (I<sup>2</sup>C) to the PCI and PCI-E slots. The default setting is Open (Disabled.) Both jumpers must be set to the same setting. See the table on the right for jumper settings.

I <sup>2</sup> C to PCI/PCI-E Slots Jumper Settings		
Jumper Settings		Definition
JI <sup>2</sup> C1: Closed	JI <sup>2</sup> C2: Closed	Enabled
JI <sup>2</sup> C1: Open	JI <sup>2</sup> C2: Open	Disabled

## 5-11 Onboard Indicators

### LAN1/LAN2 LEDs

The Ethernet ports (located beside the VGA port) have two LEDs. On each Gb LAN port, one LED indicates activity when blinking while the other LED may be green, amber or off to indicate the speed of the connection. See the table on the right for the functions associated with the connection speed LED.

LAN LED (Connection Speed Indicator)	
LED Color	Definition
Off	10 Mb/s
Green	100 Mb/s
Amber	1 Gb/s

### Onboard Power LED

An Onboard Power LED is located at LE1. When this LED is lit, the system is on. Be sure to turn off the system and unplug the power cord before removing or installing components. See the table at right for more information.

Onboard PWR LED	
LED Color	Definition
Off	System Off (PWR cable not connected)
Green	System Power On

### Rear UID LED

The rear UID LED is located at LE2 on the backplane. This LED is used in conjunction with the front UID LED on the Front Control Panel and the rear UID switch to provide easy identification of a system in need of service. Refer to UID Switch/LEDs on page 5-19 for more information.

---

## 5-12 SATA Port Connections

### SATA Ports

There are no jumpers to enable the SATA ports, which are designated I-SATA0 ~ I-SATA5. See the table on the right for pin definitions.

SATA Port Pin Definitions	
Pin #	Definition
1	Ground
2	TXP
3	TXN
4	Ground
5	RXN
6	RXP
7	Ground

## 5-13 Installing Software

After the hardware has been installed, you should first install the operating system and then the drivers. The necessary drivers are all included on the Supermicro CDs that came packaged with your serverboard.

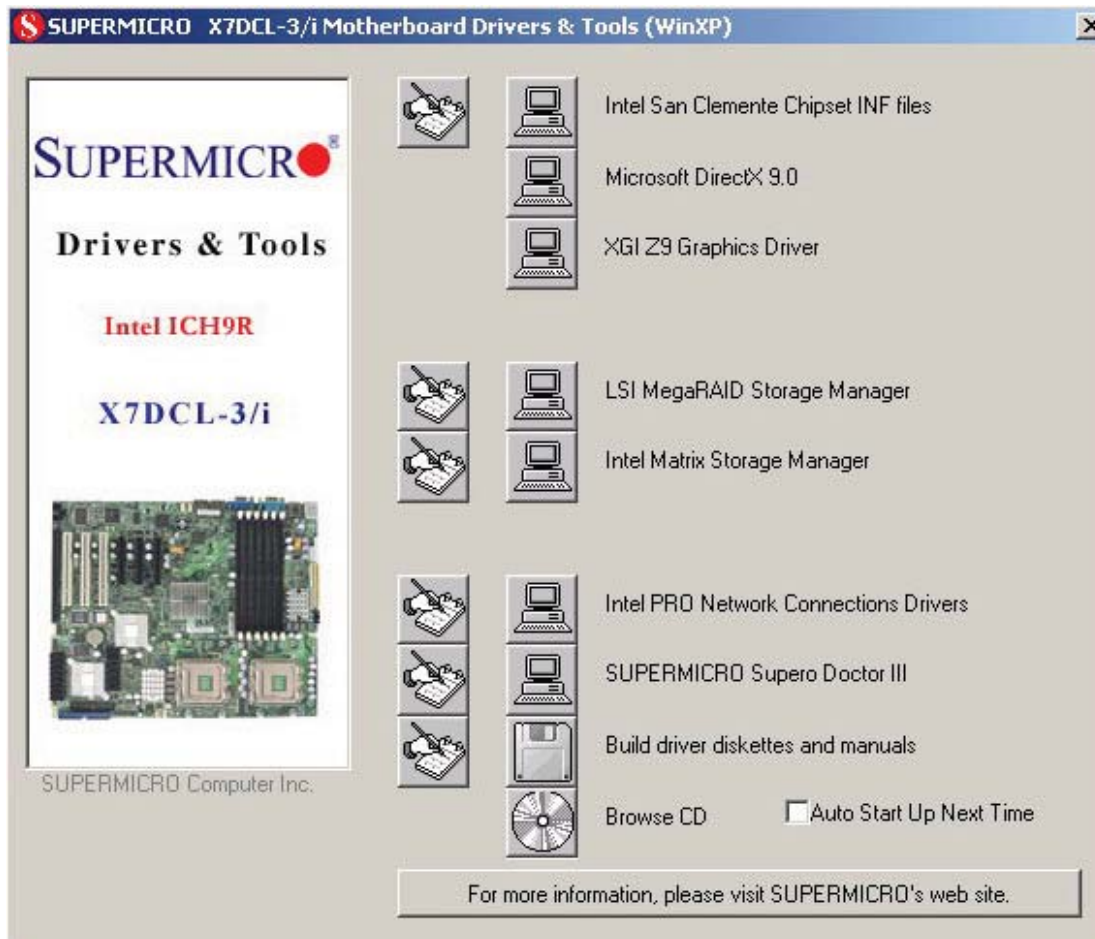

### Driver/Tool Installation Display Screen

**Note:** Click the icons showing a hand writing on paper to view the readme files for each item. Click the computer icons to the right of these items to install each item (from top to the bottom) one at a time. **After installing each item, you must re-boot the system before moving on to the next item on the list.** The bottom icon with a CD on it allows you to view the entire contents of the CD.

## Supero Doctor III

The Supero Doctor III program is a Web base management tool that supports remote management capability. It includes Remote and Local Management tools. The local management is called SD III Client. The Supero Doctor III program included on the CD-ROM that came with your serverboard allows you to monitor the environment and operations of your system. Supero Doctor III displays crucial system information such as CPU temperature, system voltages and fan status. See the Figure below for a display of the Supero Doctor III interface.

**Note:** The default User Name and Password for SuperDoctor III is ADMIN / ADMIN.

**Note:** When SuperDoctor III is first installed, it adopts the temperature threshold settings that have been set in BIOS. Any subsequent changes to these thresholds must be made within Super Doctor, as the Super Doctor settings override the BIOS settings. To set the BIOS temperature threshold settings again, you would first need to uninstall SuperDoctor III.

### Supero Doctor III Interface Display Screen (Health Information)

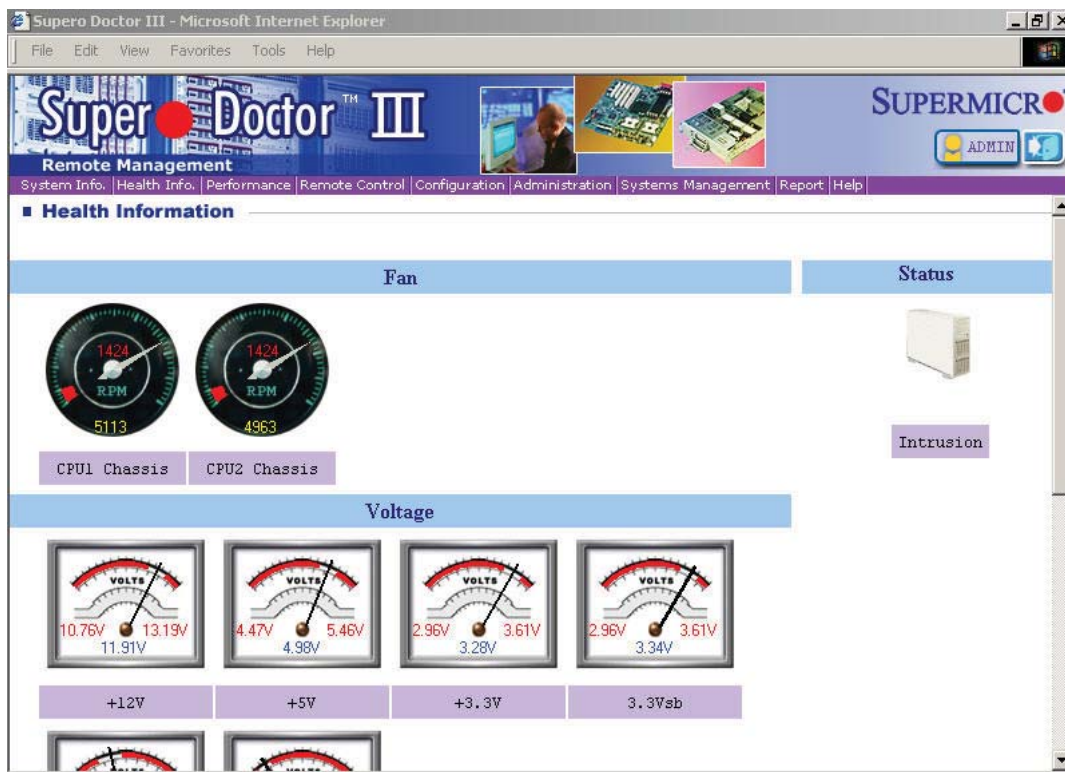

## Supero Doctor III Interface Display Screen (Remote Control)



**Graceful power control**

Supero Doctor III allows a user to inform the OS to reboot or shut down within a specified time (the default is 30 seconds). Before the system reboots or shuts down, it's allowed to cancel the action.

**Requirements**

Keep Supero SD3Service Daemon running at all times on this system.  
Provide TCP/IP connectivity.

**Power control**

Note: SD III Software Revision 1.0 can be downloaded from our Web Site at: [ftp://ftp.supermicro.com/utility/Supero\\_Doctor\\_III/](ftp://ftp.supermicro.com/utility/Supero_Doctor_III/). You can also download the SDIII User's Guide at: <http://www.supermicro.com/PRODUCT/Manuals/SDIII/UserGuide.pdf>. For Linux, we will recommend using Supero Doctor II.

## Chapter 6

# Advanced Chassis Setup

This chapter covers the steps required to install components and perform maintenance on the SC512F-520B chassis. For component installation, follow the steps in the order given to eliminate the most common problems encountered. If some steps are unnecessary, skip ahead to the step that follows.

**Tools Required:** The only tool you will need to install components and perform maintenance is a Philips screwdriver.

### 6-1 Static-Sensitive Devices

Electrostatic discharge (ESD) can damage electronic components. To prevent damage to any printed circuit boards (PCBs), it is important to handle them very carefully.

The following measures are generally sufficient to protect your equipment from ESD damage.

#### Precautions

- Use a grounded wrist strap designed to prevent static discharge.
- Touch a grounded metal object before removing any board from its antistatic bag.
- Handle a board by its edges only; do not touch its components, peripheral chips, memory modules or gold contacts.
- When handling chips or modules, avoid touching their pins.
- Put the serverboard, add-on cards and peripherals back into their antistatic bags when not in use.
- For grounding purposes, make sure your computer chassis provides excellent conductivity between the power supply, the case, the mounting fasteners and the serverboard.

## Unpacking

The serverboard is shipped in antistatic packaging to avoid static damage. When unpacking the board, make sure the person handling it is static protected.

**Figure 6-1. Chassis Views**

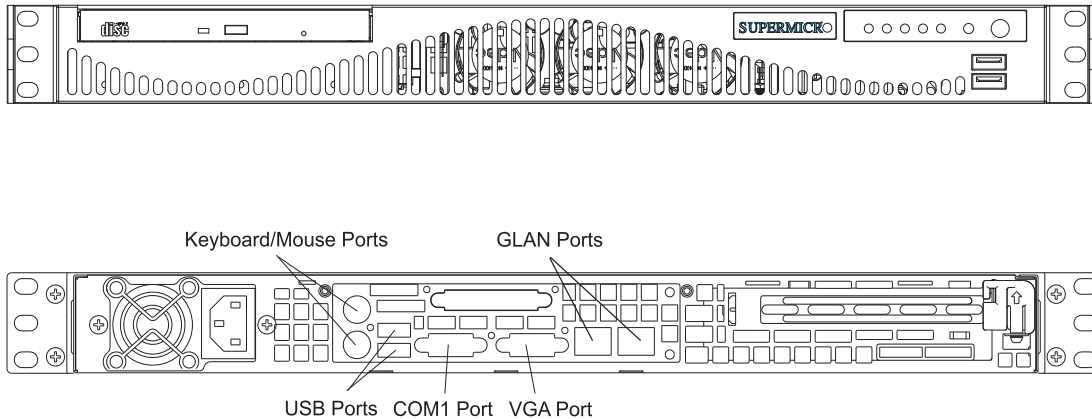

## 6-2 Control Panel

The control panel (located on the front of the chassis) must be connected to the JF1 connector on the serverboard to provide you with system control buttons and status indicators. These wires have been bundled together in a ribbon cable to simplify the connection.

Connect the cable from JF1 on the serverboard to the Control Panel PCB (printed circuit board). Make sure the red wire plugs into pin 1 on both connectors. Pull all excess cabling out of the airflow path.

The LEDs inform you of system status. See Chapter 3 for details on the LEDs and the control panel buttons. Details on JF1 can be found in Chapter 5.

## 6-3 System Fans

The 6016T-MR employs three sets of 4-cm counter-rotating fans to provide cooling. Each fan unit is made up of two fans joined back-to-back, which rotate in opposite directions. This counter-rotating action generates exceptional airflow and works to dampen vibration levels. The fans can adjust their speed according to the heat level sensed in the system, which results in more efficient and quieter fan operation. Fan speed is controlled by a setting in BIOS (see Chapter 7). Each fan in a set has its own separate tachometer.

**Note:** It is very important that the chassis top cover is properly installed for the airflow to circulate properly through the chassis and cool the components.

### System Fan Failure

If a fan fails, the remaining fans will ramp up to full speed and the overheat/fan fail LED on the control panel will blink on and off. Replace any failed fan at your earliest convenience with the same type and model (the system can continue to run with a failed fan).

#### *Replacing System Fans (Figure 6-2)*

1. Remove the chassis cover to see which fan has failed.
2. Power down the server and remove the AC power cord.
3. Detach the fan wiring then grasp the failed fan unit and lift it out of the chassis.
4. Replace the failed fan with an identical 4-cm, 12 volt fan (see Appendix C).
5. Push the new fan into the vacant space in the housing making sure the arrows on the top of the fan (indicating air direction) point in the same direction as the arrows on the other fans.
6. Reposition the fan housing back over the two mounting posts in the chassis, then reconnect the fan wires to the same chassis fan headers you removed them from.
7. Power up the system and check that the fan is working properly and that the LED on the control panel has turned off. Finish by replacing the chassis cover.

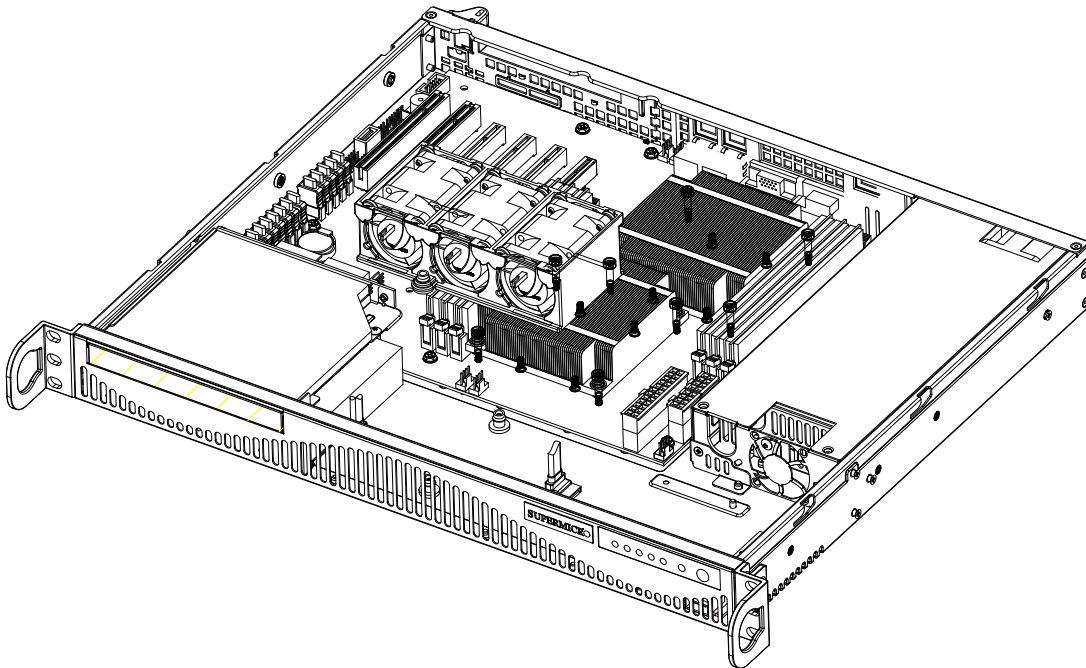
**Figure 6-2. System Cooling Fans**

## 6-4 Drive Bay Installation/Removal

### Accessing the Drive Bays

DVD-ROM/Serial ATA Drives: For installing or removing the DVD-ROM or SATA drive, you will need to gain access to the inside of the server by removing the top cover of the chassis. **Note:** Only a "slim" DVD-ROM will fit in the 6016T-MR.

#### ***Serial ATA Drive Installation***

The SATA drive is not hot-swappable, meaning system power must be turned off before installing or removing.

1. First power down the system and then remove the top cover of the chassis as described on page 6-7.
2. Unscrew the retention screw at the top center of the drive, then push the drive tray out from the back until you can grasp and pull it out through the front of the chassis.

3. Remove the drive from the drive tray.
4. To add a new SATA drive, install a drive into the tray with the printed circuit board side facing down and so that the mounting holes align with those in the tray.
5. Secure the drive to the tray with the four screws.
6. Replace the top cover when finished. See Figure 6-3.

**Note:** the 6016T-MR can accommodate two internal SATA hard drives, one on each side of the fans.



Enterprise level hard disk drives are recommended for use in Supermicro chassis and servers. For information on recommended HDDs, visit the Supermicro Web site at <http://www.supermicro.com/products/nfo/storage.cfm>

## DVD-ROM Drive Installation

The top cover of the chassis must be opened to gain full access to the DVD-ROM drive bay. The DVD-ROM must have a "slim" profile to fit into the 6016T-MR. If you cannot remove the top cover with the system remaining in the rack, follow the procedure below.

### *DVD-ROM Drive Installation*

1. First shutdown the system and disconnect the AC power cable.
2. Make sure the system is supported from underneath then remove the front bracket screws that secure the unit to the rack.
3. Carefully lift the server out of the rack.
4. Open the cover by following the procedure described on page 6-7.
5. Remove the screws that secure the DVD-ROM drive to the chassis and then lift the drive out of the chassis. See Figure 6-3.

**Note:** A red mark on a ribbon cable typically designates the location of pin 1.

Figure 6-3. Removing the DVD-ROM Drive

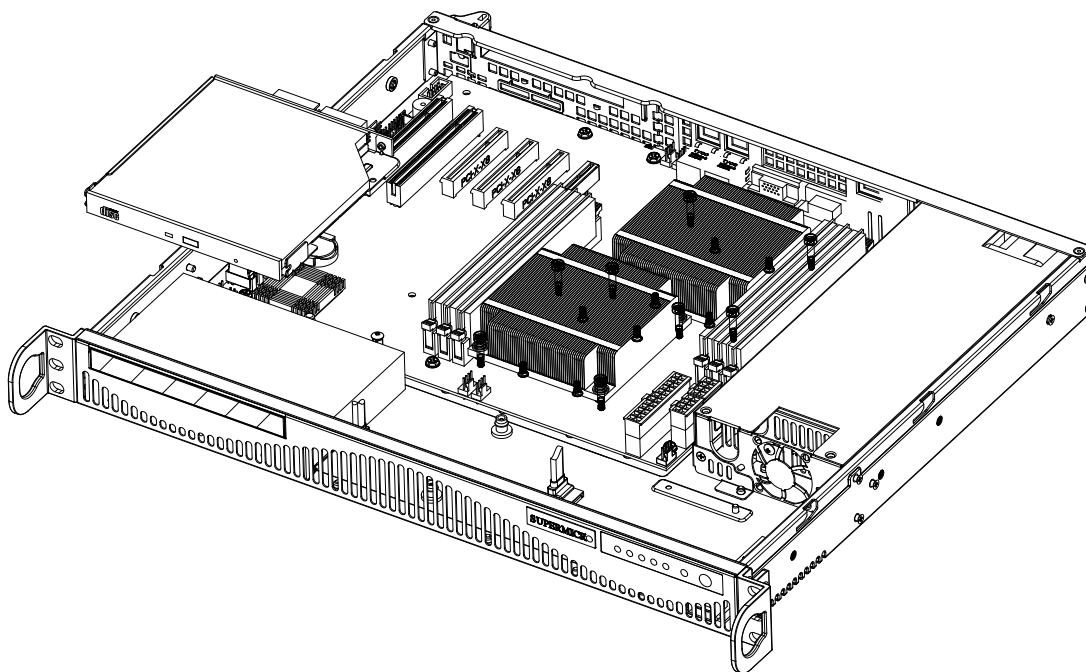

## 6-5 Power Supply

The 6016T-MR has a single 520 watt power supply. This power supply has the capability of operating at a 100 or 240 input voltage. You must power down the system and then unplug the AC power cord to completely remove power from the system before removing the power supply.

### Power Supply Failure

If the power supply unit fails, the system will shut down and you will need to replace the power supply unit. Replacement units can be ordered directly from Supermicro (see part numbers in Appendix C and contact information in Chapter 1).

#### *Accessing the Inside of the System*

1. Power down the system and remove the AC power cord.
2. Grasp the two handles on either side and pull the unit straight out until it locks (you will hear a "click").
3. Next, remove the screws from the lips on either side of the cover then depress the two buttons on the cover to release it.
4. Push the cover away from you then lift it from the chassis to gain full access to the inside of the server.

#### *Replacing the Power Supply*

1. To remove the failed power unit, remove the two screws on the back of the power supply and a third from the front of the power supply, which secures it to the bottom of the chassis.
2. Lift the unit straight out of the chassis. (The power cord should have already been removed.)
3. Replace the failed unit with another unit of the same wattage. You must replace it with the exact same power supply.
4. Carefully insert the new unit into position in the chassis and secure it with the two screws at the rear of the unit and the third at the front.

5. Reconnect the power cord, replace the chassis top cover and push the unit back into the rack.
6. Finish by turning on the power switch on the power supply, then depress the power button on the front of the system.

# Chapter 7

## BIOS

### 7-1 Introduction

This chapter describes the AMI BIOS Setup Utility for the X8DTL-i motherboard. The AMI ROM BIOS is stored in a Flash EEPROM and can be easily updated. This chapter describes the basic navigation of the AMI BIOS Setup Utility setup screens.

#### Starting BIOS Setup Utility

To enter the AMI BIOS Setup Utility screens, press the <Delete> key while the system is booting up.



**Note:** In most cases, the <Delete> key is used to invoke the AMI BIOS setup screen. There are a few cases when other keys are used, such as <F1>, <F2>, etc.

Each main BIOS menu option is described in this manual. The Main BIOS setup menu screen has two main frames. The left frame displays all the options that can be configured. Grayed-out options cannot be configured. Options in blue can be configured by the user. The right frame displays the key legend. Above the key legend is an area reserved for a text message. When an option is selected in the left frame, it is highlighted in white. Often a text message will accompany it. (**Note:** the AMI BIOS has default text messages built in. Supermicro retains the option to include, omit, or change any of these text messages.)

The AMI BIOS Setup Utility uses a key-based navigation system called "hot keys". Most of the AMI BIOS setup utility "hot keys" can be used at any time during the setup navigation process. These keys include <F1>, <F10>, <Enter>, <ESC>, arrow keys, etc.



**Note:** Options printed in **Bold** are default settings.

#### How To Change the Configuration Data

The configuration data that determines the system parameters may be changed by entering the AMI BIOS Setup utility. This Setup utility can be accessed by pressing <Del> at the appropriate time during system boot.



**Note:** For AMI BIOS Recovery, please refer to the AMI BIOS Recovery Instructions posted on our website at <http://www.supermicro.com/support/manuals/>.

## Starting the Setup Utility

Normally, the only visible Power-On Self-Test (POST) routine is the memory test. As the memory is being tested, press the <Delete> key to enter the main menu of the AMI BIOS Setup Utility. From the main menu, you can access the other setup screens. An AMI BIOS identification string is displayed at the left bottom corner of the screen below the copyright message.



**Warning!** Do not upgrade the BIOS unless your system has a BIOS-related issue. Flashing the wrong BIOS can cause irreparable damage to the system. In no event shall Supermicro be liable for direct, indirect, special, incidental, or consequential damages arising from a BIOS update. If you have to update the BIOS, do not shut down or reset the system while the BIOS is updating. This is to avoid possible boot failure.

## 7-2 Main Setup

When you first enter the AMI BIOS Setup Utility, you will enter the Main setup screen. You can always return to the Main setup screen by selecting the Main tab on the top of the screen. The Main BIOS Setup screen is shown below.

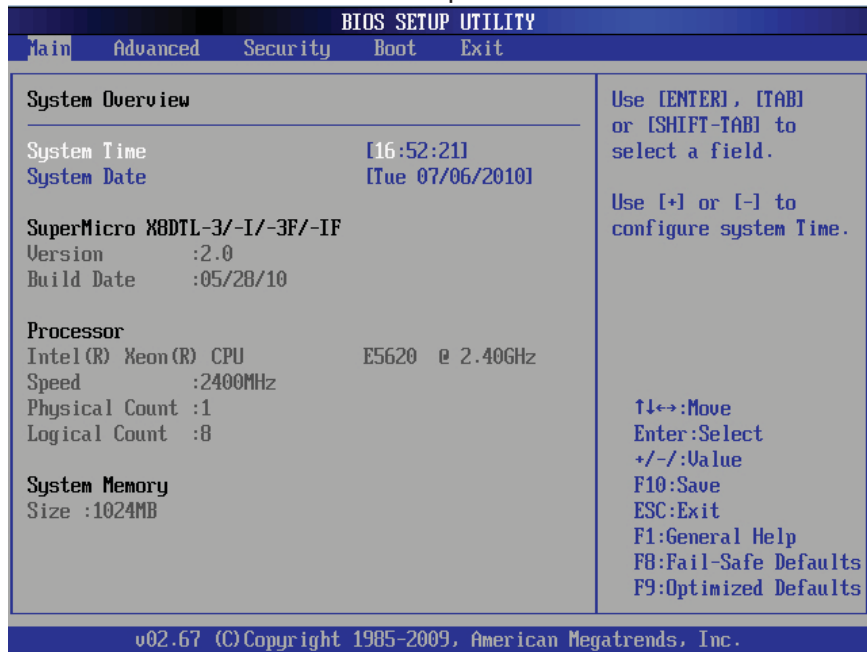

**System Overview:** The following BIOS information will be displayed:

### System Time/System Date

Use this option to change the system time and date. Highlight *System Time* or *System Date* using the arrow keys. Key in new values through the keyboard and press <Enter>. Press the <Tab> key to move between fields. The date must be entered in MM/DD/YY format. The time is entered in HH:MM:SS format. (**Note:** The time is in the 24-hour format. For example, 5:30 P.M. appears as 17:30:00.)

**Supermicro X8DTL-3/i/3F/iF**

- **Version:** This item displays the BIOS revision used in your system.
- **Build Date:** This item displays the date when this BIOS was completed.

**Processor**

The AMI BIOS will automatically display the status of the processor used in your system:

- **CPU Type:** This item displays the type of CPU used in the motherboard.
- **Speed:** This item displays the speed of the CPU detected by the BIOS.
- **Physical Count:** This item displays the number of processors installed in your system as detected by the BIOS.
- **Logical Count:** This item displays the number of CPU Cores installed in your system as detected by the BIOS.

**System Memory**

This displays the size of memory available in the system.

## 7-3 Advanced Setup Configurations

Use the arrow keys to select Boot Setup and hit <Enter> to access the submenu items:

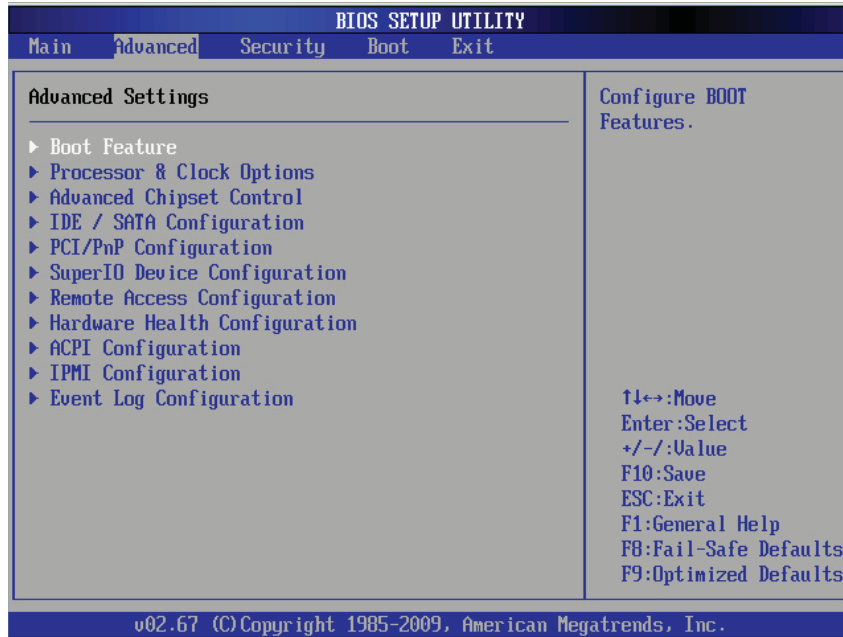

### ► Boot Features

#### Quick Boot

Select Enabled to skip certain tests during POST to reduce the time needed for system boot. The options are **Enabled** and Disabled.

#### Quiet Boot

Select Enabled to choose the bootup screen display between the POST messages or the OEM logo. Select Disabled to display the POST messages. Select Enabled to display the OEM logo instead of the normal POST messages. The options are **Enabled** and Disabled.

#### AddOn ROM Display Mode

Use this feature to configure Option ROM mode settings. The options are **Force BIOS** and Keep Current.

#### Bootup Num-Lock

Select On to turn on the Numlock key at bootup. The options are Off and **On**.

#### Wait For 'F1' If Error

Select Enabled to force the system to wait until the user presses the <F1> key when an error occurs. The options are Disabled and **Enabled**.

### Hit 'Del' Message Display

If this feature is set to Enabled, the message: "Press DEL to run Setup" will be displayed during POST. The options are **Enabled** and Disabled.

### Interrupt 19 Capture

Interrupt 19 is the software interrupt that handles the boot disk function. When this item is set to Enabled, the ROM BIOS of the host adaptors will "capture" Interrupt 19 at boot and allow the drives that are attached to these host adaptors to function as bootable disks. If this item is set to Disabled, the ROM BIOS of the host adaptors will not capture Interrupt 19, and the drives attached to these adaptors will not function as bootable devices. The options are **Enabled** and Disabled.

## Power Configuration

### Watch Dog Function

If enabled, the Watch Dog Timer will cause the system to reboot when it is inactive for more than 5 minutes. The options are Enabled and **Disabled**.

### Power Button Function

If this item is set to Instant\_Off, the system will power off immediately as soon as the user hits the power button. If set to 4\_Second\_Override, the system will power off when the user presses the power button for 4 seconds or longer. The options are **Instant\_Off** and 4\_Second\_Override.

### Restore on AC Power Loss

Use this feature to set the power state after a power outage. Select Power-Off for the system power to remain off after a power loss. Select Power-On for the system power to be turned on after a power loss. Select Last State to allow the system to resume its last state before a power loss. The options are Power-On, Power-Off and **Last State**.

### Resume On RTC Alarm

Use this feature to set an event alarm using the Real Time Clock (RTC) to "wake up" the system at specified times. The options are Enabled and **Disabled**. If this feature is enabled, the following items will display:

#### RTC Alarm Date (Days) (Available if Resume on RTC Alarm is Enabled)

This option appears if Resume On RTC Alarm is Enabled. The options are **Every Day** and 1 ~ 31 (corresponding to the days of the month.)

#### RTC Alarm Time (Available if Resume on RTC Alarm is Enabled)

Set the time when the system wakes up during the day specified under the RTC Alarm Date above.

---

## ► Processor and Clock Options

This submenu displays the status of the processor used in the motherboard and allows the user to configure the Processor and Clock settings.

- **Type of the CPU:** This item displays the CPU type for the motherboard.
- **Frequency:** This item displays the CPU frequency for the motherboard.
- **CPUID:** This item displays the CPUID for the motherboard.
- **Microcode Revision:** This item displays the CPUID for the motherboard.
- **Cache L1:** This item displays the size of Cache L1 of the CPU for the motherboard.
- **Cache L2:** This item displays the size of Cache L2 of the CPU for the motherboard.
- **Cache L3:** This item displays the size of Cache L3 of the CPU for the motherboard.
- **Ratio Status:** This item displays the status of the CPU ratio.
- **Ratio Actual Value:** This item displays the actual value of the CPU ratio.

### Clock Spread Spectrum

Select Enable to enable Clock Spectrum support, which will allow the BIOS to monitor and attempt to reduce the level of Electromagnetic Interference caused by the components whenever needed. The options are **Disabled** and **Enabled**.

### Hardware Prefetcher (Available when supported by the CPU)

If enabled, the hardware prefetcher will prefetch streams of data and instructions from the main memory to the L2 cache in the forward or backward manner to improve CPU performance. The options are **Disabled** and **Enabled**.

### Adjacent Cache Line Prefetch (Available when supported by the CPU)

The CPU prefetches the cache line for 64 bytes if this option is set to **Disabled**. The CPU prefetches both cache lines for 128 bytes as comprised if this item is set to **Enabled**. The options are **Disabled** and **Enabled**.

### MPS and ACPI MADT Ordering

This feature allows the user to configure the MPS (Multi-Processor Specifications) and ACPI settings for your motherboard. Select **Modern Ordering** if the XP or a

newer version of Windows OS is used in the motherboard. Select Legacy Ordering if the 2000 or an earlier version of Windows OS is used. The options are **Modern Ordering** and Legacy Ordering.

#### **Intel® Virtualization Technology (Available when supported by the CPU)**

Select Enabled to enable Virtualization Technology support and allows one platform to run multiple operating systems and applications in independent partitions, creating multiple "virtual" systems in one physical computer. The options are **Enabled** and Disabled. **Note:** If there is any change to this setting, you will need to power off and restart the system for the change to take effect. Please refer to Intel's web site for detailed information.

#### **Execute-Disable Bit Capability (Available if supported by the OS and the CPU)**

Select Enabled to enable Execute\_Disable\_Bit support which will allow the processor to designate areas in the system memory where an application code can execute and where it cannot, thus preventing a worm or a virus from flooding illegal codes to overwhelm the processor or damage the system during an attack. The default is **Enabled**. (Refer to Intel and Microsoft Web Sites for more information.)

#### **Simultaneous Multi-Threading (Available when supported by the CPU)**

Set to Enabled to use the Simultaneous Multi-Threading Technology to enhance CPU performance. The options are Disabled and **Enabled**.

#### **Intel AES-NI**

Select Enable to use the Intel Advanced Encryption Standard (AES) New Instructions (NI) to ensure data security. The options are **Disabled** and Enabled.

#### **Active Processor Cores**

Set to Enabled to use a processor's Second Core and beyond. (Please refer to Intel's web site for more information.) The options are **All**, 1, and 2.

#### **Intel® EIST Technology**

EIST (Enhanced Intel SpeedStep Technology) allows the system to automatically adjust processor voltage and core frequency in an effort to reduce power consumption and heat dissipation. **Please refer to Intel's web site for detailed information.** The options are Disabled and **Enabled**.

#### **Intel® TurboBoost Technology (Available when EIST Tech. is enabled)**

Select Enabled to enable Turbo Mode support to boost system performance. The options are **Enabled**, and Disabled.

### **C1E Support**

Select Enabled to enable Enhanced Halt State support. C1E significantly reduces the CPU's power consumption by reducing the CPU's clock cycle and voltage during a "Halt State". The options are Disabled and **Enabled**.

### **Intel® C-STATE Tech**

If enabled, C-State is set by the system automatically to C2, C3, or C4 state. The options are Disabled and **Enabled**.

### **C-State Package Limit Setting (Available when the C-State Tech is enabled)**

If set to Auto, the AMI BIOS will automatically set a limit on the C-State package register. The options are **Auto**, C1, C3, C6, and C7.

### **C1 Auto Demotion**

When this feature is enabled, the CPU will conditionally demote C3, C6 or C7 requests to C1 based on un-core auto-demote information. The options are **Enabled** and Disabled.

### **C3 Auto Demotion**

When this feature is enabled, the CPU will conditionally demote C6 or C7 requests to C3 based on un-core auto-demote information. The options are **Enabled** and Disabled.

### **ACPI T State**

Select Enabled to report CPU throttling state in ACPI. The options are Enabled and **Disabled**.

## **► Advanced Chipset Control**

### **► CPU Bridge Configuration**

This feature allows the user to configure CPU Bridge settings.

- **CPU Revision:** This item displays the CPU revision number.
- **Current QPI Frequency:** This item displays current QPI frequency.
- **Current CPU Memory Frequency:** displays current CPU memory frequency.
- **Memory Reference Code** displays the memory reference code.
- **QPI Reference Code** displays the QPI reference code for the motherboard.

**Request Transaction ID (Available for the Intel Xeon 5600 platform only)**

QuickPath Interconnect (QPI) is the connection between the CPUs and the I/O hub (IOH). For a transaction to be processed in the QPI, a "Transaction ID" is required, and it is assigned by an agent (CPU1, CPU2 or the IOH). Each agent is allocated a number of Transaction IDs based on the QPI IO Bandwidth and the Request Transaction ID (RTID) setting (32-24-32 or 32-16-40). Once Transaction IDs are allocated to an agent, it will assign a Transaction ID to an event so that it can be processed in the QPI. Select **Balanced** to allocate transaction IDs to an agent based on the setting 32-24-32. Select **IO Bias** to allocate RTIDs based on the setting 32-16-40. The options are **Balanced** and **IO Bias**.

**QPI (Quick Path Interconnect) Links Speed**

This feature is used to set data transfer speed for QPI Link connections. The options are **Slow-Mode** and **Full-Speed**.

**QPI Links Speed**

This feature selects QPI's data transfer rate. The options are **Slow-mode**, and **Full Speed**.

**QPI Frequency**

This selects the desired QPI frequency. The options are **Auto**, 4.800GT, 5.866GT, 6.400GT.

**QPI L0s and L1**

This enables the QPI power state to lower power consumption. L0s and L1 are automatically selected by the motherboard. The options are **Enabled** and **Disabled**.

**Memory Frequency**

This feature forces a DDR3 memory module to run at a specific frequency. The available options are **Auto**, Force DDR-800, Force DDR-1066, Force DDR-1333, and Force SPD.

**Memory Mode**

If this item is set to **Independent**, all DIMMs are available to the operating system. If this item is set to **Channel Mirroring**, the motherboard maintains two identical copies of all data in memory for redundancy. If this item is set to **Lockstep**, the motherboard uses two areas of memory to run the same set of operations in parallel. Select **Sparing** to use memory sparing and create data redundancy in memory modules for data security. (Sparing is supported by the Westmere-EP platform.) The options are **Independent**, **Channel Mirroring**, **Sparing**, and **Lockstep**.

**Demand Scrubbing**

It is a memory error-correction scheme where the processor writes corrected data back into the memory block from where it was read by the processor. The options are Enabled and **Disabled**.

**Patrol Scrubbing**

It is a memory error-correction scheme that works in the background looking for and correcting resident errors. The options are **Enabled** and Disabled.

**Throttling - Closed Loop**

Throttling improves reliability and reduces CPU power by automatic voltage control during CPU idle states. The options are **Enabled** and Disabled.

**► NorthBridge Chipset Configuration**

This feature allows the user to configure North Bridge settings. The items included in the submenu are listed below.

- **NB Revision:** This item displays North Bridge revision number.

**Intel I/OAT**

The Intel I/OAT (I/O Acceleration Technology) significantly reduces CPU overhead by leveraging CPU architectural improvements, freeing resources for more other tasks. The options are Disabled and **Enabled**.

**DCA Technology (Available when Intel I/OAT is enabled)**

Select Enabled to use Intel's DCA (Direct Cache Access) Technology to enhance data transfer efficiency. The options are **Enabled** and Disabled.

**DCA Prefetch Delay**

A DCA Prefetch is used with TOE components to prefetch data in order to shorten execution cycles and maximize data processing efficiency. Prefetching too frequently can saturate the cache directory and delay necessary cache accesses. This feature reduces or increases the frequency the system prefetches data. The options are [8], [16], [24], **[32]**, [40], [48], [56], [64], [72], [80], [88], [96], [104], [112], [120].

**Intel VT-d**

Select Enabled to enable Intel's Virtualization Technology support for Direct I/O VT-d by reporting the I/O device assignments to VMM through the DMAR ACPI Tables. This feature offers fully-protected I/O resource-sharing across the Intel platforms, providing the user with greater reliability, security and availability in networking and data-sharing. The options are Enabled and **Disabled**.

### **Active State Power Management**

Select Enabled to use the power management for signal transactions between the PCI Express L0 and L1 Links. Select Enabled to configure PCI-Exp. L0 and L1 Link power states. The options are **Disabled** and Enabled.

### **IOH PCI-E Max Payload Size**

Some add-on cards perform faster with the coalesce feature, which limits the payload size to 128B; while others, with a payload size of 256B which inhibits the coalesce feature. Please refer to your add-on card user guide for the desired setting. The options are **256B** and 128B.

## **► South Bridge Configuration**

### **USB Functions**

Select Enabled to use USB devices. The Options are: Disabled and **Enabled**.

### **Legacy USB Support**

Select Enabled to use Legacy USB devices. If this item is set to Auto, Legacy USB support will be automatically enabled if a legacy USB device is installed on the motherboard, and vice versa. The settings are Disabled, **Enabled** and Auto.

### **Port60h/64h Emulation**

Select Enabled to enable 60h/64h emulation for complete USB keyboard support for operating systems that are not compatible with USB devices. The options are Enabled and **Disabled**.

### **USB 2.0 Controller (Available when the item: USB Functions is disabled)**

This display indicates if the onboard USB 2.0 controller is activated.

### **USB 2.0 Controller Mode**

This setting allows you to select the USB 2.0 Controller mode. The options are **Hi-Speed (480 Mbps)** and Full Speed (12 Mbps).

### **BIOS EHCI Hand-Off**

Select Enabled to enable BIOS Enhanced Host Controller Interface support to provide a workaround solution for an operating system that does not have EHCI Hand-Off support. When enabled, the EHCI Interface will be changed from the BIOS-controlled to the OS-controlled. The options are Disabled and **Enabled**.

### **Route Port 80h Cycles to**

This feature allows the user to decide which bus to send debug information to. The options are Disabled, PCI and **LPC**.

## ► IDE/SATA Configuration

When this submenu is selected, the AMI BIOS automatically detects the presence of the IDE devices and displays the following items:

### SATA#1 Configuration

If **Compatible** is selected, it sets SATA#1 to legacy compatibility mode, while selecting **Enhanced** sets SATA#1 to native SATA mode. The options are **Disabled**, **Compatible** and **Enhanced**.

#### Configure SATA#1 as

This feature allows the user to select the drive type for SATA#1. The options are **IDE**, **RAID** and **AHCI**. (When **RAID** is selected, the items: "AHCI CodeBase" and "ICH RAID Code Base" will appear. When **AHCI** is selected, the item "AHCI CodeBase" will be available.)

#### AHCI CodeBase (Available when RAID or AHCI is selected)

Select **BIOS Native Module** to use the BIOS Native Module for AHCI Interface (Advanced Host Controller Interface). Select **Intel AHCI ROM** to use the Intel AHCI ROM for AHCI Interface. (Take caution when using this function. This feature is for advanced programmers only.) The options are **BIOS Native Module** and **Intel AHCI ROM**. If the item is set to "IDE", the following item will display.

#### ICH RAID Code Base (Available when the option-RAID is selected)

Select **Intel** to enable Intel's SATA RAID firmware to configure Intel SATA RAID settings. Select **Adaptec** to enable Adaptec's firmware to configure Adaptec SATA RAID settings. The options are **Intel** and **Adaptec**.

### SATA#2 Configuration (Available when the option "IDE" is selected)

Selecting **Enhanced** will set SATA#2 to native SATA mode. The options are **Disabled**, and **Enhanced**.

#### IDE Detect Timeout (sec)

Use this item to set the timeout value for the BIOS to detect the ATA, ATAPI devices installed in the system. The options are 0 (sec), 5, 10, 15, 20, 25, 30, and **35**.

#### Primary IDE Master/Slave, Secondary IDE Master/Slave, Third IDE Master, and Fourth IDE Master

These settings allow the user to set the parameters of the slots indicated above. Press <Enter> to activate the following submenu. Set the correct configurations accordingly. The items included in the submenu are listed below.

**Type**

Use this item to select the type of device connected to the system. The options are Not Installed, **Auto**, CD/DVD and ARMD.

**LBA/Large Mode**

LBA (Logical Block Addressing) is a method of addressing data on a disk drive. In the LBA mode, the maximum drive capacity is 137 GB. For drive capacities over 137 GB, your system must be equipped with a 48-bit LBA mode addressing. If not, contact your manufacturer or install an ATA/133 IDE controller card that supports 48-bit LBA mode. The options are Disabled and **Auto**.

**Block (Multi-Sector Transfer)**

Block Mode boosts the IDE drive performance by increasing the amount of data transferred. Only 512 bytes of data can be transferred per interrupt if Block Mode is not used. Block Mode allows transfers of up to 64 KB per interrupt. Select Disabled to allow data to be transferred from and to the device one sector at a time. Select Auto to allow data transfer from and to the device occur multiple sectors at a time if the device supports it. The options are **Auto** and Disabled.

**PIO Mode**

The IDE PIO (Programmable I/O) Mode programs timing cycles between the IDE drive and the programmable IDE controller. As the PIO mode increases, the cycle time decreases. The options are **Auto**, 0, 1, 2, 3, and 4.

Select Auto to allow the AMI BIOS to automatically detect the PIO mode. Use this value if the IDE disk drive support cannot be determined.

Select 0 to allow the AMI BIOS to use PIO mode 0. It has a data transfer rate of 3.3 MB/s.

Select 1 to allow the AMI BIOS to use PIO mode 1. It has a data transfer rate of 5.2 MB/s.

Select 2 to allow the AMI BIOS to use PIO mode 2. It has a data transfer rate of 8.3 MB/s.

Select 3 to allow the AMI BIOS to use PIO mode 3. It has a data transfer rate of 11.1 MB/s.

Select 4 to allow the AMI BIOS to use PIO mode 4. It has a data transfer bandwidth of 32-Bits. Select Enabled to enable 32-Bit data transfer.

**DMA Mode**

Select Auto to allow the BIOS to automatically detect IDE DMA mode when the IDE disk drive support cannot be determined.

Select SWDMA0 to allow the BIOS to use Single Word DMA mode 0. It has a data transfer rate of 2.1 MB/s.

---

Select SWDMA1 to allow the BIOS to use Single Word DMA mode 1. It has a data transfer rate of 4.2 MB/s.

Select SWDMA2 to allow the BIOS to use Single Word DMA mode 2. It has a data transfer rate of 8.3 MB/s.

Select MWDMA0 to allow the BIOS to use Multi Word DMA mode 0. It has a data transfer rate of 4.2 MB/s.

Select MWDMA1 to allow the BIOS to use Multi Word DMA mode 1. It has a data transfer rate of 13.3 MB/s.

Select MWDMA2 to allow the BIOS to use Multi-Word DMA mode 2. It has a data transfer rate of 16.6 MB/s.

Select UDMA0 to allow the BIOS to use Ultra DMA mode 0. It has a data transfer rate of 16.6 MB/s. It has the same transfer rate as PIO mode 4 and Multi Word DMA mode 2.

Select UDMA0 to allow the BIOS to use Ultra DMA mode 0. It has a data transfer rate of 16.6 MB/s. It has the same transfer rate as PIO mode 4 and Multi Word DMA mode 2.

Select UDMA1 to allow the BIOS to use Ultra DMA mode 1. It has a data transfer rate of 25 MB/s.

Select UDMA2 to allow the BIOS to use Ultra DMA mode 2. It has a data transfer rate of 33.3 MB/s.

Select UDMA3 to allow the BIOS to use Ultra DMA mode 3. It has a data transfer rate of 44.4 MB/s.

Select UDMA4 to allow the BIOS to use Ultra DMA mode 4. It has a data transfer rate of 66.6 MB/s.

Select UDMA5 to allow the BIOS to use Ultra DMA mode 5. It has a data transfer rate of 100 MB/s.

Select UDMA6 to allow the BIOS to use Ultra DMA mode 6. It has a data transfer rate of 133 MB/s. The options are **Auto**, SWDMA<sub>n</sub>, MWDMA<sub>n</sub>, and UDMA<sub>n</sub>.

## ► PCI/PnP Configuration

### Clear NVRAM

Select Yes to clear the Non-Volatile Random Access (Flash) Memory (NVRAM) during system boot. The options are **No** and Yes.

### Plug & Play OS

Selecting Yes allows the OS to configure Plug & Play devices. (This is not required for system boot if your system has an OS that supports Plug & Play.) Select **No** to allow the AMI BIOS to configure all devices in the system.

**PCI Latency Timer**

This feature sets the latency Timer for each PCI device installed on a PCI bus. Select 64 to set the PCI latency Timer to 64 PCI clock cycles. The options are 32, **64**, 96, 128, 160, 192, 224 and 248.

**PCI IDE BusMaster**

When this item is enabled, the BIOS uses PCI bus mastering for reading/writing to IDE drives. The options are Disabled and **Enabled**.

**SR-IOV Supported**

Single Root I/O Virtualization is an industry-standard mechanism that allows devices to be shared simultaneously among several virtual machines. SR-IOV is capable of partitioning a PCI function into several virtual interfaces in order to share the resources of a PCI Express (PCIe) device under a virtual environment. The options are **Disabled** and Enabled.

**Slot 1 PCI 33MHz, Slot 2 PCI 33MHz, Slot 3 PCIE x4 in X8 Slot, Slot 4 PCIE x8, Slot 5 PCIE x4 in x8 Slot, Slot 6 PCIE x8 in x16 Slot**

This feature allows you to Enable or Disable any of the PCI slots. The options are **Enable** and Disable.

**Onboard LAN Option ROM Select**

Select iSCSI to use iSCSI Option ROMs to boot the computer using a network device. Select iSCSI to use PXE Option ROMs to boot the computer using a network device. The options are iSCSI and **PXE**.

**Load Onboard LAN1 Option ROM/Load Onboard LAN2 Option ROM**

Select Enabled to enable Onboard LAN1/LAN2 Option ROM which will allow you to boot computer using a network connection. The options are Enabled and **Disabled**.

**Load Onboard SAS Option ROM (Available when SAS is enabled on the X8DTL-3/-3F)**

Select Enabled to enable Onboard SAS Option ROM which will allow you to boot computer using a SAS connection. The options are **Enabled** and Disabled.

**Boot Graphics Adapter Priority**

This option allows the user to specify which graphics controller to be used as the primary boot device. The options are **Onboard VGA** and Offboard VGA.

## ► Super IO Device Configuration

### Serial Port1 Address/ Serial Port2 Address

This option specifies the base I/O port address and the Interrupt Request address of Serial Port 1 and Serial Port 2. Select Disabled to prevent the serial port from accessing any system resources. When this option is set to Disabled, the serial port physically becomes unavailable. Select 3F8/IRQ4 to allow the serial port to use 3F8 as its I/O port address and IRQ 4 for the interrupt address. The options for Serial Port1 are Disabled, **3F8/IRQ4**, 2F8/IRQ3, 3E8/IRQ4, 2E8/IRQ3. The options for Serial Port2 are Disabled, 3F8/IRQ4, **2F8/IRQ3**, 3E8/IRQ4, and 2E8/IRQ3.

### Serial Port 2 Attribute

This feature allows the user to set Serial Port 2 as a normal serial port or a virtual COM port for Serial-Over-LAN (SOL). The options are **SOL** and COM.

## ► Remote Access Configuration

### Remote Access

This allows the user to enable Remote Access support. The options are **Enabled** and Disabled. If Remote Access is set to Enabled, the following items will display:

### Serial Port Number

This feature allows the user decide which serial port to be used for Console Redirection. The options are COM 1 and **COM 2**.

### Base Address, IRQ

This item displays the based address and IRQ of the serial port specified above. The default setting is 2F8h, 3.

### Serial Port Mode

This feature allows the user to set the serial port mode for Console Redirection. The options are **115200 8, n 1**; 57600 8, n, 1; 38400 8, n, 1; 19200 8, n, 1; and 9600 8, n, 1.

### Flow Control

This feature allows the user to set the flow control for Console Redirection. The options are **None**, Hardware, and Software.

### Redirection After BIOS POST

Select Disabled to turn off Console Redirection after Power-On Self-Test (POST). Select Always to keep Console Redirection active all the time after POST. (**Note:** This setting may not be supported by some operating systems.) Select Boot Loader

to keep Console Redirection active during POST and Boot Loader. The options are Disabled, Boot Loader, and **Always**.

### **Terminal Type**

This feature allows the user to select the target terminal type for Console Redirection. The options are ANSI, **VT100**, and VT-UTF8.

### **VT-UTF8 Combo Key Support**

A terminal keyboard definition that provides a way to send commands from a remote console. The options are **Enabled** and Disabled.

### **Sredir Memory Display Delay**

This feature defines the length of time in seconds to display memory information. The options are **No Delay**, Delay 1 Sec, Delay 2 Sec, and Delay 4 Sec.

## **► Hardware Health Event Monitoring**

This feature allows the user to monitor system health and review the status of each item as displayed.

### **CPU Overheat Alarm**

This option allows the user to select the CPU Overheat Alarm setting which determines when the CPU OH alarm will be activated to provide warning of possible CPU overheat.

 **Warning!** 1. Any temperature that exceeds the CPU threshold temperature predefined by the CPU manufacturer may result in CPU overheat or system instability. When the CPU temperature reaches this predefined threshold, the CPU and system cooling fans will run at full speed. 2. To avoid possible system overheating, please be sure to provide adequate airflow to your system.

The options are:

- **The Early Alarm:** Select this setting to trigger the CPU overheat alarm (including the LED and the buzzer) as soon as the CPU temperature reaches the CPU overheat threshold as predefined by the CPU manufacturer.
- **The Default Alarm:** Select this setting to trigger the CPU overheat alarm (including the LED and the buzzer) when the CPU temperature reaches about 5°C above the threshold temperature as predefined by the CPU manufacturer to give the CPU and system fans additional time needed for CPU and system cooling. In both the alarms above, please take immediate action as shown below.

## **CPU 1 Temperature/CPU 2 Temperature/IOH Temperature/System Temperature**

This feature displays current temperature readings for CPU 1, CPU 2, and the System.

The following items will be displayed for your reference only:

### **CPU 1 Temperature/CPU 2 Temperature**

The CPU Temperature feature will display the CPU temperature status as detected by the BIOS:

**Low** – This level is considered as the ‘normal’ operating state. The CPU temperature is well below the CPU ‘Temperature Tolerance’. The motherboard fans and CPU will run normally as configured in the BIOS (Fan Speed Control).

User intervention: No action required.

**Medium** – The processor is running warmer. This is a ‘precautionary’ level and generally means that there may be factors contributing to this condition, but the CPU is still within its normal operating state and below the CPU ‘Temperature Tolerance’. The motherboard fans and CPU will run normally as configured in the BIOS. The fans may adjust to a faster speed depending on the Fan Speed Control settings.

User intervention: No action is required. However, consider checking the CPU fans and the chassis ventilation for blockage.

**High** – The processor is running hot. This is a ‘caution’ level since the CPU’s ‘Temperature Tolerance’ has been reached (or has been exceeded) and may activate an overheat alarm. The system may shut down if it continues for a long period to prevent damage to the CPU.

User intervention: If the system buzzer and Overheat LED has activated, take action immediately by checking the system fans, chassis ventilation and room temperature to correct any problems.

### **Notes:**

-  1. The CPU thermal technology that reports absolute temperatures (Celsius/Fahrenheit) has been upgraded to a more advanced feature by Intel in its newer processors. The basic concept is each CPU is embedded by unique temperature information that the motherboard can read. This ‘Temperature Threshold’ or ‘Temperature Tolerance’ has been assigned at the factory and is the baseline on which the motherboard takes action during different CPU temperature conditions (i.e., by increasing CPU Fan speed, triggering the Overheat Alarm, etc). Since CPUs can have different ‘Temperature Tolerances’, the installed CPU can now send information to the motherboard what its ‘Temperature Tolerance’ is, and not the other way around. This results in better CPU thermal management.

Supermicro has leveraged this feature by assigning a temperature status to certain thermal conditions in the processor (Low, Medium and High). This makes

---

it easier for the user to understand the CPU's temperature status, rather than by just simply seeing a temperature reading (i.e., 25°C).

The information provided above is for your reference only. For more information on thermal management, please refer to Intel's Web site at [www.Intel.com](http://www.Intel.com).

2. To avoid possible system overheating, please provide adequate airflow to the system.

### **IOH Temperature/System Temperature**

The IOH Temperature and the system temperature will be displayed (in degrees in Celsius and Fahrenheit) as detected by the BIOS.

### **Fan Speed Readings**

This feature displays the fan speed readings from Fan 1 through Fan 6.

### **Fan Speed Control Modes**

This feature allows the user to decide how the system controls the speeds of the onboard fans. The CPU temperature and the fan speed are correlated. When the CPU on-die temperature increases, the fan speed will also increase for effective system cooling. Select "Full Speed/FS" to allow the onboard fans to run at full speed for maximum cooling. The FS setting is recommended for special system configuration or debugging. Select "Performance/PF" for better system cooling. The PF setting is recommended for high-power-consuming and high-density systems. Select "Balanced/BL" for the onboard fans to run at a speed that will balance the needs between system cooling and power saving. The BL setting is recommended for regular systems with normal hardware configurations. Select "Energy Saving/ES" for best power efficiency and maximum quietness. The Options are: Full Speed/FS, Performance/PF, **Balanced/BL**, and Energy Saving/ES.

### **Voltage Readings**

The following voltage readings will be displayed.

CPU1 Vcore, CPU2 Vcore, CUP1 DIMM, CPU DIMM, 5V, 5VSB, 12V, -12V, 3.3Vcc, 3.3VSB, VBAT and Vtt

### **►ACPI Configuration**

Use this feature to configure Advanced Configuration and Power Interface (ACPI) power management settings for your system.

### **High Precision Event Timer**

Select Enabled to activate the High Precision Event Timer (HPET) that produces periodic interrupts at a much higher frequency than a Real-time Clock (RTC) does in synchronizing multimedia streams, providing smooth playback and reducing

the dependency on other timestamp calculation devices, such as an x86 RDTSC Instruction embedded in the CPU. The High Performance Event Timer is used to replace the 8254 Programmable Interval Timer. The options are **Enabled** and Disabled.

#### **ACPI Aware O/S**

Enable ACPI support if it is supported by the OS to control ACPI through the Operating System. Otherwise, disable this feature. The options are **Yes** and No.

#### **ACPI APIC Support**

Select Enabled to include the ACPI APIC Table Pointer in the RSDT (Root System Description Table) pointer list. The options are **Enabled** and Disabled.

#### **APIC ACPI SCI IRQ**

When this item is set to Enabled, APIC ACPI SCI IRQ is supported by the system. The options are Enabled and **Disabled**.

#### **Headless Mode**

Select Enabled for the system to function normally without a keyboard, monitor and/or mouse attached. The options are Enabled and **Disabled**.

#### **ACPI Version Features**

Use this feature to select the appropriate ACPI Version for your system to ensure that the correct RSDP (Root System Description Pointer) Table is used by the system. The options are ACPI v1.0, **ACPI v2.0** and ACPI v3.0. For more information, please refer to ACPI's website at <http://www.acpi.info/>.

#### **NUMA Support**

Select Enabled to use the feature of Non-Uniform Memory Access to improve CPU performance. The options are **Enabled** and Disabled.

#### **WHEA Support**

Select Enabled to enable Windows Hardware Error Architecture (WHEA) support which will provide a common infrastructure for the system to handle hardware errors on Windows platforms in order to reduce system crashes due to hardware errors and to enhance system recovery and health monitoring. The default setting is **Enabled**.

## ► Trusted Computing (Available when a TPM device is detected and the TPM jumper is enabled)

### TCG/TPM (Trusted Platform Module) Support

Select Yes on this item and enable the TPM jumper on the motherboard to enable TCG (TPM 1.1/1.2)/TPM support in order to improve data integrity and network security. The options are **No** and Yes. If this feature is set to Yes, the following items will display:

#### Indicate Physical

Select Yes for the BIOS to show if a TPM Physical device is present. The options are **No** and Yes.

#### TPM Deactivated

Select Set to disable TPM support. Select Clear to enable TPM support. Select Don't Change to keep the current TPM support setting. The options are **Don't change**, Set, and Clear.

#### TPM Owner

Select Don't Change to keep the current TPM Owner setting. Select Enable Install to add a user to the TPM Owner account. Select Disable Install to prevent a user from adding a TPM Owner account. Select Clear to remove a user from the TPM Owner account. Select Don't Change to keep the current TPM Owner setting. The options are **Don't change**, Enable Install, Disable Install, and Clear.

#### TPM Enable/Disable Status

This item displays the status of TPM Enabled/Disabled state.

#### TPM Owner Status

This item displays the status of TPM Ownership.

## ► IPMI Configuration (For X8DTL-3F/iF only)

Intelligent Platform Management Interface (IPMI) is a set of common interfaces that IT administrators can use to monitor system health and to manage the system as a whole. For details on IPMI, please visit Intel's website at [www.intel.com](http://www.intel.com).

**IPMI Firmware Revision:** This item displays the current IPMI firmware revision.

#### Status of BMC

Baseboard Management Controller (BMC) manages the interface between system management software and platform hardware. This feature displays the status code of the BMC controller.

## ►View BMC System Event Log

This feature displays the BMC System Event Log (SEL). It shows the total number of entries of BMC System Events. To view an event, select an Entry Number and pressing <Enter> to display the information as shown in the screen.

- Total Number of Entries
- SEL Entry Number
- SEL Record ID
- SEL Record Type
- Event Timestamp
- Generator ID
- Event Message Format Version
- Event Sensor Type
- Event Sensor Number
- Event Dir Type
- Event Data.

## Clear BMC System Event Log

Select OK and press the <Enter> key to clear the BMC system log. Select Cancel to keep the BMC System log. The options are **OK** and Cancel.



**Caution:** Make sure that you no longer need any data stored in the event log before clearing the BMC Event Log because you will not be able to recover any data included in the event log once you've "cleared" it.

## ►Set LAN Configuration

Set this feature to configure the IPMI LAN adapter with a network address as shown in the following graphics.

**Channel Number** - Enter the channel number for the SET LAN Configuration command. This is initially set to **[01]**. Press <+> or <-> on your keyboard to change the Channel Number.

**Channel Number Status** - This feature returns the channel status for the Channel Number selected above: "Channel Number is OK" or "Wrong Channel Number".

---

### **IP Address Source**

Select the source of this machine's IP address. If Static is selected, you will need to know the IP address of this machine and enter it to the system manually in the field below. If DHCP is selected, the BIOS will search for a DHCP (Dynamic Host Configuration Protocol) server in the network it is attached to, and request the next available IP address. The options are **DHCP** and Static.

The following items are assigned IP addresses automatically if DHCP is selected under IP Address Source above:

### **IP Address**

Enter the IP address for this machine. This should be in decimal and in dotted quad form (i.e., 192.168.10.253). The value of each three-digit number separated by dots should not exceed 255 as shown in the screen below.

### **Subnet Mask**

Subnet masks tell the network which subnet this machine belongs to. The value of each three-digit number separated by dots should not exceed 255.

### **Gateway Address**

This is the IP address of the gateway in the network. This is usually a router.

### **Mac Address**

The BIOS will automatically enter the Mac address of this machine; however it may be over-ridden. Mac addresses are 6 two-digit hexadecimal numbers (Base 16, 0 ~ 9, A, B, C, D, E, F) separated by dots. (i.e., 00.30.48.D0.D4.60).

### **BMC Watch Dog Timer Action**

Allows the BMC (Baseboard Management Controller) Watch Dog to reset or power down the system if the operating system hangs or crashes. The options are **Disabled**, Reset System, Power Down, Power Cycle.

#### **BMC Watch Dog TimeOut [Min:Sec]**

This option appears if BMC Watch Dog Timer Action is not set to Disabled. This is a timed delay in minutes or seconds before a system power-down or system reset after an operating system failure is detected. The options are **[5 Min]**, [1 Min], [30 Sec], and [10 Sec].

## **►Event Log Configuration**

### **View Event Log**

Use this option to view the System Event Log.

**Mark all events as read**

Select "OK" to mark all events as read. The options are OK and Cancel.

**Clear event log**

Select "OK" to clear all messages from the Event Log. The options are OK and Cancel.

**PCIE Error Log**

Select Yes to enable PCI-E error (PERR) logging. The options are Yes and **No**.

**Memory ECC Error Log**

Select Yes to activate and display ECC Memory Error event log. The options are Yes and No.

## 7-4 Security Settings

The AMI BIOS provides a Supervisor and a User password. If you use both passwords, the Supervisor password must be set first.

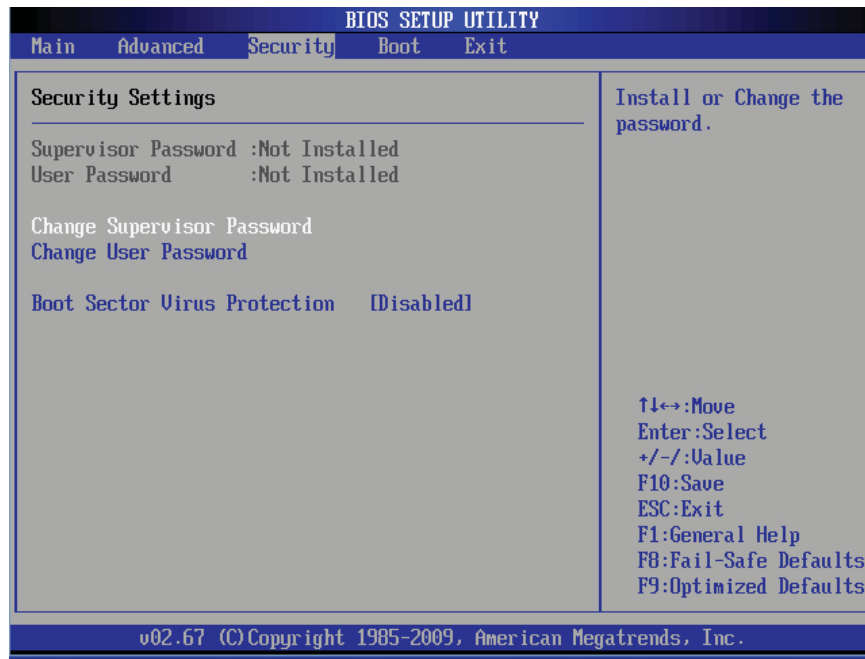
**Supervisor Password**

This item indicates if a Supervisor password has been entered for the system. "Not Installed" means a Supervisor password has not been used.

**User Password**

This item indicates if a user password has been entered for the system. "Not Installed" means that a user password has not been used.

### Change Supervisor Password

Select this feature and press <Enter> to access the submenu, and then enter a new Supervisor Password.

### User Access Level (Available when Supervisor Password is set as above)

Select **Full Access** to grant the User full access to the Setup Utility, and change Setup settings. Select **View Only** to allow the user access to the Setup Utility and view the settings without making changes. Select **Limited** to allow the user to change selected settings such as Date and Time. Select **No Access** to prevent the User from accessing the Setup Utility.

### Change User Password

Select this feature and press <Enter> to access the submenu, and enter a new User Password.

### Clear User Password (Available only when User Password has been set)

This item allows you to clear a user password after it has been entered.

### Password Check

This item allows you to check a password after it has been entered. The options are **Setup** and **Always**.

### Boot Sector Virus Protection

If this feature is enabled, the AMI BIOS displays a warning when any program (or virus) issues a Disk Format command or attempts to write to the boot sector of the hard disk drive. The options are **Enabled** and **Disabled**.

## 7-5 Boot Configuration



### ► Boot Device Priority

This feature allows the user to specify the priority sequence of boot devices, including the 1st boot device, 2nd boot device, 3rd boot device, 4th boot device and 5th boot device. The options are Removable Devices, Hard Drive, CD/DVD, USB, Network, and Disabled.

- 1st Boot Device - [Removable Dev.]
- 2nd Boot Device - [CD/DVD]

### ► Hard Disk Drives

This feature allows the user to specify the boot sequence from all available hard disk drives. The settings are Disabled and a list of all hard disk drives that have been detected (i.e., 1st Drive, 2nd Drive, 3rd Drive, etc).

- 1st Drive - [SATA: XXXXXXXXXX]

### ► Removable Drives

This feature allows the user to specify the boot sequence from available Removable Drives. The settings are 1st boot device, 2nd boot device, and Disabled.

- 1st Drive - [USB: XXXXXXXXXX / 2nd Drive]

### ► CD/DVD Drives

This feature allows the user to specify the boot sequence from available CD/DVD Drives.

### ► USB Drives

This feature allows the user to specify the boot sequence from available USB Drives.

### ► Network Drives

This feature allows the user to specify the boot sequence from available Network Drives.

### Retry Boot Devices

If this feature is enabled, the system will continue to search for the next boot device if the current boot device is not available. The options are Enabled, and **Disabled**.

## 7-6 Exit Options

Select the Exit tab from the AMI BIOS Setup Utility screen to enter the Exit BIOS Setup screen.

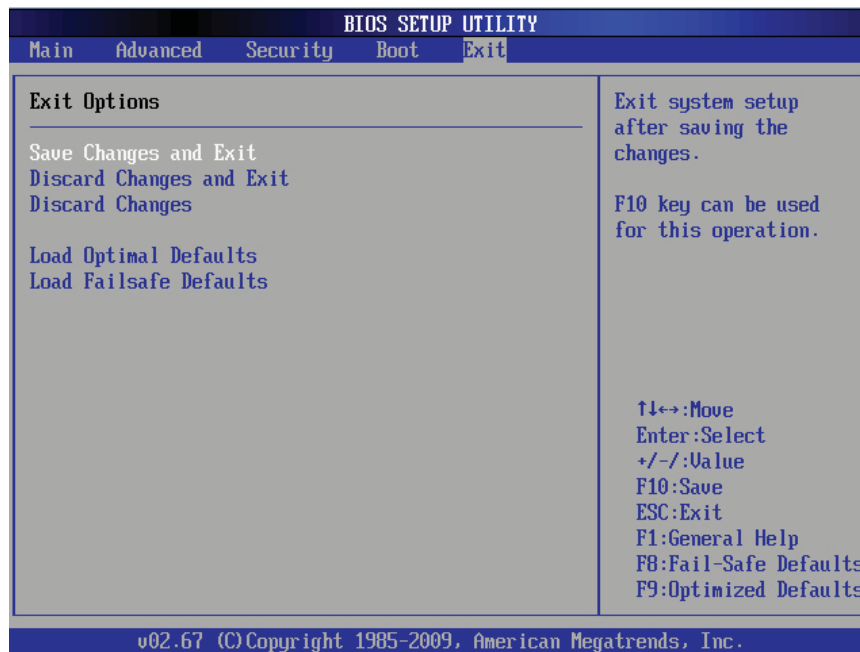

### Save Changes and Exit

After configuration the Setup settings, select this option to save the changes and exit the BIOS Setup Utility. The system will then reboot, and new system parameters will become effective.

### Discard Changes and Exit

Select this option to exit the BIOS Setup without making changes to the BIOS settings.

### Discard Changes

Select this option to discard all the changes and return to the Setup Utility.

### Load Optimal Defaults

Select this feature for the AMI BIOS to automatically load Optimal Defaults to the BIOS Settings to maximize system performance. This option might not work best for some computer applications.

### Load Fail-Safe Defaults

Select this feature for the AMI BIOS to automatically load Fail-Safe Defaults to the BIOS Settings for maximum system stability but not for maximum performance.

## Notes

---

## Appendix A

### BIOS Post Error Codes

During the POST (Power-On Self-Test) routines, which are performed each time the system is powered on, errors may occur.

**Non-fatal errors** are those which, in most cases, allow the system to continue the boot-up process. The error messages normally appear on the screen.

**Fatal errors** are those which will not allow the system to continue the boot-up procedure. If a fatal error occurs, you should consult with your system manufacturer for possible repairs.

These fatal errors are usually communicated through a series of audible beeps. The numbers on the fatal error list correspond to the number of beeps for the corresponding error.

#### A-1 BIOS Error Beep Codes

BIOS Error Beep Codes		
Beep Code	Error Message	Description
1 beep	Refresh	Circuits have been reset. (Ready to power up)
5 short beeps + 1 long beep	Memory error	No memory detected in the system
8 beeps	Display memory read/write error	Video adapter missing or with faulty memory
1 continuous beep w/ Front Panel OH LED on	System Overheat	1 continuous beep with the front panel OH LED on

# Notes

## Appendix B

### Installing Windows

After all hardware components have been installed, you must first configure Intel South Bridge RAID Settings before you install the Windows OS and other software drivers. To configure RAID settings, please refer to RAID Configuration User Guides posted on our website at [www.supermicro.com/support/manuals](http://www.supermicro.com/support/manuals).

#### B-1 Installing Windows to a RAID System

1. Insert Microsoft's Windows Setup CD in the CD drive and the system will start booting up from CD.
2. Press the <F6> key when the message "Press F6 if you need to install a third party SCSI or RAID driver" displays.
3. When the Windows setup screen appears, press "S" to specify additional device(s).
4. Insert the driver diskette "Intel AA RAID XP/2003/2008/Vista Driver for ICH10R" into the floppy drive and press the <Enter> key.
5. Choose the Intel(R) ICH10R *SATA RAID Controller* from the list indicated in the Windows setup screen, and press the <Enter> key.
6. Press the <Enter> key to continue the installation process. (If you need to specify any additional devices to be installed, do it at this time.) Once all devices are specified, press the <Enter> key to continue with the installation.
7. From the Windows OS setup screen, press the <Enter> key. The Windows setup will automatically load all device files and then continue the installation.
8. After the Windows installation is completed, the system will automatically reboot.

## **B-2 Installing Windows to a Non-RAID System**

1. Insert Microsoft's Windows setup CD in the CD drive and the system will start booting up from CD.
2. Continue with the OS installation. The Windows OS Setup screen will display.
3. From the Windows setup screen, press the <Enter> key. The Windows setup will automatically load all device files and then continue with the installation.
4. After the Windows installation is complete, the system will automatically reboot.
5. Insert the Supermicro setup CD that came with your motherboard into the CD drive during system boot, and the main screen will display.

# Appendix C

## System Specifications

### Processors

Two Intel® 5600/5500 Series processors in LGA1366 sockets

**Note:** please refer to our website for details on supported processors.

### Chipset

Intel 5500/ICH10R

### BIOS

32 Mb AMI SPI Flash ROM

### Memory Capacity

Six DIMM slots that can support up to 48 GB of ECC registered or 24 GB of unbuffered DDR3-1333/1066/800 SDRAM

**Note:** refer to Section 5-6 for details.

### Serial ATA Controller

Intel ICH10R on-chip controller to support six 3 Gb/s Serial ATA (RAID 0, 1)

### Drive Bays

One internal SATA hard drive. The internal drive is not hot-swappable.

### PCI Expansion

One PCI-Express card (with pre-installed riser card)

### Serverboard

X8DTL-i

Dimensions: 12 x 10 in (305 x 254 mm)

### Chassis

SC512F-520B (Mini 1U Rackmount)

Dimensions: (WxHxD) 17.3 x 1.7 x 14.5 in. (439 x 43 x 368 mm)

### Weight

Gross Weight: 18 lbs. (8.2 kg.)

### **System Cooling**

Three (3) 4-cm counter-rotating fans

### **System Input Requirements**

AC Input Voltage: 100-240 VAC

Rated Input Current: 7A ~ 3A max. (100-240V)

Rated Input Frequency: 50 to 60 Hz

### **Power Supply**

Rated Output Power: 520W (Part# PWS-521-1H)

Rated Output Voltages: +3.3V (16A), +5V (20A), +12V<sub>ALL</sub> (39A), -12V (0.5A), +5Vsb (3A)

### **Operating Environment**

Operating Temperature: 0° to 35° C (32° to 95° F)

Non-operating Temperature: -40° to 70° C (-40° to 158° F)

Operating Relative Humidity: 20% to 95% (non-condensing)

Non-operating Relative Humidity: 5 to 95% (non-condensing)

### **Regulatory Compliance**

Electromagnetic Emissions: FCC Class A, EN 55022 Class A, EN 61000-3-2/-3-3, CISPR 22 Class A

Electromagnetic Immunity: EN 55024/CISPR 24, (EN 61000-4-2, EN 61000-4-3, EN 61000-4-4, EN 61000-4-5, EN 61000-4-6, EN 61000-4-8, EN 61000-4-11)

Safety: CSA/EN/IEC/UL 60950-1 Compliant, UL or CSA Listed (USA and Canada), CE Marking (Europe)

California Best Management Practices Regulations for Perchlorate Materials:  
This Perchlorate warning applies only to products containing CR (Manganese Dioxide) Lithium coin cells. "Perchlorate Material-special handling may apply. See [www.dtsc.ca.gov/hazardouswaste/perchlorate](http://www.dtsc.ca.gov/hazardouswaste/perchlorate)"

## Notes

(continued from front)

The products sold by Supermicro are not intended for and will not be used in life support systems, medical equipment, nuclear facilities or systems, aircraft, aircraft devices, aircraft/emergency communication devices or other critical systems whose failure to perform be reasonably expected to result in significant injury or loss of life or catastrophic property damage. Accordingly, Supermicro disclaims any and all liability, and should buyer use or sell such products for use in such ultra-hazardous applications, it does so entirely at its own risk. Furthermore, buyer agrees to fully indemnify, defend and hold Supermicro harmless for and against any and all claims, demands, actions, litigation, and proceedings of any kind arising out of or related to such ultra-hazardous use or sale.