

SUPERO®

SUPERSERVER

8016B-6F

8016B-TF

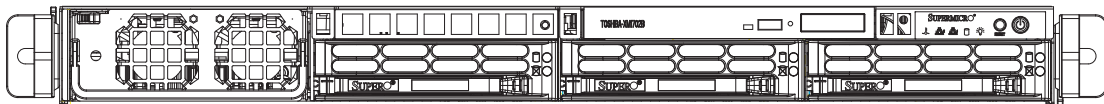

USER'S MANUAL

Revision 1.0a

The information in this User's Manual has been carefully reviewed and is believed to be accurate. The vendor assumes no responsibility for any inaccuracies that may be contained in this document, makes no commitment to update or to keep current the information in this manual, or to notify any person or organization of the updates. **Please Note: For the most up-to-date version of this manual, please see our web site at www.supermicro.com.**

Super Micro Computer, Inc. ("Supermicro") reserves the right to make changes to the product described in this manual at any time and without notice. This product, including software and documentation, is the property of Supermicro and/or its licensors, and is supplied only under a license. Any use or reproduction of this product is not allowed, except as expressly permitted by the terms of said license.

IN NO EVENT WILL SUPERMICRO BE LIABLE FOR DIRECT, INDIRECT, SPECIAL, INCIDENTAL, SPECULATIVE OR CONSEQUENTIAL DAMAGES ARISING FROM THE USE OR INABILITY TO USE THIS PRODUCT OR DOCUMENTATION, EVEN IF ADVISED OF THE POSSIBILITY OF SUCH DAMAGES. IN PARTICULAR, SUPERMICRO SHALL NOT HAVE LIABILITY FOR ANY HARDWARE, SOFTWARE, OR DATA STORED OR USED WITH THE PRODUCT, INCLUDING THE COSTS OF REPAIRING, REPLACING, INTEGRATING, INSTALLING OR RECOVERING SUCH HARDWARE, SOFTWARE, OR DATA.

Any disputes arising between manufacturer and customer shall be governed by the laws of Santa Clara County in the State of California, USA. The State of California, County of Santa Clara shall be the exclusive venue for the resolution of any such disputes. Super Micro's total liability for all claims will not exceed the price paid for the hardware product.

FCC Statement: This equipment has been tested and found to comply with the limits for a Class A digital device pursuant to Part 15 of the FCC Rules. These limits are designed to provide reasonable protection against harmful interference when the equipment is operated in a commercial environment. This equipment generates, uses, and can radiate radio frequency energy and, if not installed and used in accordance with the manufacturer's instruction manual, may cause harmful interference with radio communications. Operation of this equipment in a residential area is likely to cause harmful interference, in which case you will be required to correct the interference at your own expense.

California Best Management Practices Regulations for Perchlorate Materials: This Perchlorate warning applies only to products containing CR (Manganese Dioxide) Lithium coin cells. "Perchlorate Material-special handling may apply. See www.dtsc.ca.gov/hazardouswaste/perchlorate"

WARNING: Handling of lead solder materials used in this product may expose you to lead, a chemical known to the State of California to cause birth defects and other reproductive harm.

Manual Revision 1.0a
Release Date: November 14, 2013

Unless you request and receive written permission from Super Micro Computer, Inc., you may not copy any part of this document.

Information in this document is subject to change without notice. Other products and companies referred to herein are trademarks or registered trademarks of their respective companies or mark holders.

Copyright © 2013 by Super Micro Computer, Inc.
All rights reserved.

Printed in the United States of America

Preface

About This Manual

This manual is written for professional system integrators and PC technicians. It provides information for the installation and use of the SuperServer 8016B-6F/8016B-TF. Installation and maintenance should be performed by experienced technicians only.

The SuperServer 8016B-6F/8016B-TF is a high-end quad processor server based on the SC818A-1400B 1U rackmount server chassis and the Super X8QB6-F/X8QBE-F serverboard. The X8QB6-F/X8QBE-F supports four Intel® Xeon® processor 7500 Series - please refer to our web site for an up-to-date list of supported processors.

Manual Organization

Chapter 1: Introduction

The first chapter provides a checklist of the main components included with the server system and describes the main features of the Super X8QB6-F/X8QBE-F serverboard and the SC818A-1400B chassis.

Chapter 2: Server Installation

This chapter describes the steps necessary to install the SuperServer 8016B-6F/8016B-TF into a rack and check out the server configuration prior to powering up the system. If your server was ordered without the processor and memory components, this chapter will refer you to the appropriate sections of the manual for their installation.

Chapter 3: System Interface

Refer to this chapter for details on the system interface, which includes the functions and information provided by the control panel on the chassis as well as other LEDs located throughout the system.

Chapter 4: Standardized Warning Statements

You should thoroughly familiarize yourself with this chapter for a general overview of safety precautions that should be followed when installing and servicing the SuperServer 8016B-6F/8016B-TF.

Chapter 5: Advanced Serverboard Setup

Chapter 5 provides detailed information on the X8QB6-F/X8QBE-F serverboard, including the locations and functions of connectors, headers and jumpers. Refer to this chapter when adding or removing processors or main memory and when reconfiguring the serverboard.

Chapter 6: Advanced Chassis Setup

Refer to Chapter 6 for detailed information on the SC818A-1400B 1U rackmount server chassis. You should follow the procedures given in this chapter when installing, removing or reconfiguring Serial ATA or peripheral drives and when replacing system power supply units and cooling fans.

Chapter 7: BIOS

The BIOS chapter includes an introduction to BIOS and provides detailed information on running the CMOS Setup Utility.

Appendix A: BIOS Error Beep Codes

Appendix B: System Specifications

Notes

Table of Contents

Chapter 1 Introduction

1-1	Overview	1-1
1-2	Serverboard Features	1-2
	Processors	1-2
	Memory	1-2
	SATA	1-2
	SAS	1-2
	Rear I/O Ports	1-2
	ATI Graphics Controller.....	1-3
	IPMI.....	1-3
	Other Features	1-3
1-3	Server Chassis Features	1-4
	System Power	1-4
	SAS/SATA Subsystem.....	1-4
	Front Control Panel.....	1-4
	Cooling System	1-4
1-4	Contacting Supermicro.....	1-6

Chapter 2 Server Installation

2-1	Overview	2-1
2-2	Unpacking the System	2-1
2-3	Preparing for Setup.....	2-1
	Choosing a Setup Location.....	2-1
2-4	Warnings and Precautions	2-2
	Rack Precautions	2-2
	Server Precautions.....	2-2
	Rack Mounting Considerations	2-3
	Ambient Operating Temperature	2-3
	Reduced Airflow	2-3
	Mechanical Loading	2-3
	Circuit Overloading.....	2-3
	Reliable Ground	2-3
2-5	Installing the System into a Rack	2-4
	Identifying the Sections of the Rack Rails	2-4
	Installing the Inner Rails	2-4
	Installing the Outer Rails.....	2-5
	Locking Tabs	2-5

	Installing the Server into the Rack.....	2-6
2-6	Checking the Serverboard Setup.....	2-7
2-7	Preparing to Power On	2-9
Chapter 3 System Interface		
3-1	Overview	3-1
3-2	Control Panel Buttons	3-1
3-3	Control Panel LEDs	3-2
3-4	Drive Carrier LEDs.....	3-3
Chapter 4 Standardized Warning Statements for AC Systems		
4-1	About Standardized Warning Statements.....	4-1
	Warning Definition.....	4-1
	Installation Instructions.....	4-4
	Circuit Breaker	4-5
	Power Disconnection Warning	4-6
	Equipment Installation.....	4-8
	Restricted Area.....	4-9
	Battery Handling.....	4-10
	Redundant Power Supplies	4-12
	Backplane Voltage	4-13
	Comply with Local and National Electrical Codes	4-14
	Product Disposal	4-15
	Hot Swap Fan Warning.....	4-16
	Power Cable and AC Adapter	4-18
Chapter 5 Advanced Serverboard Setup		
5-1	Handling the Serverboard	5-1
	Precautions	5-1
	Unpacking	5-2
5-2	Serverboard Installation	5-2
5-3	Connecting Cables.....	5-3
	Connecting Data Cables	5-3
	Connecting Power Cables	5-3
	Connecting the Control Panel.....	5-3
5-4	I/O Ports	5-4
5-5	Installing the Processor and Heatsink	5-5
	Memory Support.....	5-8
	Notes and Restrictions	5-10
5-7	Adding PCI Add-On Cards.....	5-10
5-8	Serverboard Details	5-11

	X8QB6-F/X8QBE-F Quick Reference	5-12
5-9	Connector Definitions	5-13
5-10	Jumper Settings	5-19
5-11	Onboard Indicators.....	5-21
5-12	SAS and SATA Ports.....	5-23
5-13	Installing Software.....	5-24
	SuperDoctor III.....	5-25

Chapter 6 Advanced Chassis Setup

6-1	Static-Sensitive Devices.....	6-1
	Precautions	6-1
6-2	Control Panel	6-2
6-3	System Fans	6-3
	System Fan Failure.....	6-3
	Replacing System Fans.....	6-3
	Removing a Fan.....	6-3
	Installing a New Fan	6-3
6-4	Drive Bay Installation	6-4
	Removing the Front Bezel	6-4
	Accessing the Drive Bays.....	6-5
	SAS/SATA Drive Installation.....	6-6
	Mounting a Drive in a Drive Carrier.....	6-6
	Installing/Removing SAS/SATA Drives.....	6-7
	SAS/SATA Backplane.....	6-7
	DVD-ROM and Floppy Drive Installation	6-8
6-5	Power Supply	6-9
	Power Supply Failure.....	6-9
	Removing the Power Supply.....	6-9
	Installing a New Power Supply	6-9

Chapter 7 BIOS

7-1	Introduction.....	7-1
7-2	Main Setup	7-2
7-3	Advanced Setup Configurations.....	7-4
7-4	Boot Configuration	7-29
7-5	Security Settings	7-30
7-6	Exit Options.....	7-31

Appendix A BIOS Error Beep Codes

Appendix B System Specifications

Chapter 1

Introduction

1-1 Overview

The 8016B-6F/8016B-TF is a high-end server comprised of two main subsystems: the SC818A-1400B 1U server chassis and the X8QB6-F/X8QBE-F serverboard. Please refer to our web site for information on operating systems that have been certified for use with the 8016B-6F/8016B-TF (www.supermicro.com).

In addition to the serverboard and chassis, various hardware components have been included with the SuperServer 8016B-6F/8016B-TF, as listed below:

- Seven 4-cm hot-swap chassis fans (FAN-0101L4)
- One air shroud (MCP-310-81804-0B)
- Four CPU passive heatsinks for 1U chassis (SNK-P0044P)
- One riser card for PCI-Express x16 (RSC-RR1U-E16)
- One slim DVD-ROM dummy drive (CSE-PT93L-B)
- One rail set (MCP-290-00016-0N)
- SATA Accessories
 - One SATA backplane (BPN-SAS-818A)
 - One 40-cm iPass to iPass cable (CBL-0108L-02)
 - Three hot-swap drive carriers (CSE-PT39-B0)
 - One HDD backplane PWS cable (CBL-0385L)

Note: For your system to work properly, please follow the links below to download all necessary drivers/utilities and the user's manual for your server.

- Supermicro product manuals: <http://www.supermicro.com/support/manuals/>
- Product drivers and utilities: <ftp://ftp.supermicro.com>
- Product safety info: http://super-dev/about/policies/safety_information.cfm
- If you have any questions, please contact our support team at: support@supermicro.com

1-2 Serverboard Features

At the heart of the SuperServer 8016B-6F/8016B-TF lies the X8QB6-F/X8QBE-F, a quad processor serverboard based on the Intel 7500/ICH10R chipset. Below are the main features of the X8QB6-F/X8QBE-F. (See Figure 1-1 for a block diagram of the chipset).

Processors

The X8QB6-F/X8QBE-F supports four Intel Xeon MP 7500 Series processors in LGA1567 sockets. Please refer to the serverboard description pages on our web site for a complete listing of supported processors (www.supermicro.com).

Memory

The X8QB6-F/X8QBE-F has 32 DIMM slots that can support up to 1024 GB of registered ECC DDR3-1066/800 SDRAM. Single channel and two-channel interleaved memory are supported. Modules of the same size and speed should be used. See Chapter 5 Section 5 for details.

SATA

A SATA controller is integrated into the South Bridge (ICH10R) section of the chipset to provide a six-port SATA subsystem, which is RAID 0, 1 and 5 supported. The SATA drives are hot-swappable units.

Note: The operating system you use must have RAID support to enable the hot-swap capability and RAID function of the SATA drives.

SAS

The 8016B-6F (X8QB6-F) includes an LSI 2108 SAS controller to provide an eight port SAS subsystem, which is RAID 0, 1 and 5 supported. The SAS drives are hot-swappable units.

Note: The operating system you use must have RAID support to enable the hot-swap capability and RAID function of the SAS drives.

Rear I/O Ports

The color-coded I/O ports include one COM port, a VGA (monitor) port, a dedicated IPMI LAN port and two Gb Ethernet ports.

ATI Graphics Controller

The X8QB6-F/X8QBE-F features an integrated Matrox G200eW video controller. The G200eW is a 2D/3D/video accelerator chip with a 128-bit core.

IPMI

IPMI (Intelligent Platform Management Interface) is a hardware-level interface specification that provides remote access, monitoring and administration for Supermicro server platforms. IPMI allows server administrators to view a server's hardware status remotely, receive an alarm automatically if a failure occurs, and power cycle a system that is non-responsive.

Other Features

Other onboard features that promote system health include onboard voltage monitors, a chassis intrusion header, auto-switching voltage regulators, chassis and CPU overheat sensors, virus protection and BIOS rescue.

1-3 Server Chassis Features

The following is a general outline of the main features of the SC818A-1400B server chassis.

System Power

The SC818A-1400B features a 1400W high-efficiency power supply with I²C. Power must be removed from the system before servicing or replacing the power supply.

SAS/SATA Subsystem

The SC818A-1400B chassis was designed to support three SAS or SATA drives, which are hot-swappable units.

Front Control Panel

The control panel on the SuperServer 8016B-6F/8016B-TF provides you with system monitoring and control. LEDs indicate system power, HDD activity, network activity, system overheat and power supply failure. A main power button and a system reset button are also included. In addition, two USB ports and a COM port have been incorporated into the front of the chassis for convenient access.

Cooling System

The SC818A-1400B chassis has an innovative cooling design that includes seven 4-cm fans located in the middle section of the chassis. The power supply module also includes a cooling fan. All chassis and power supply fans operate continuously. An air shroud channels the airflow from the system fans to efficiently cool the processors and memory.

1-4 Contacting Supermicro

Headquarters

Address: Super Micro Computer, Inc.
980 Rock Ave.
San Jose, CA 95131 U.S.A.

Tel: +1 (408) 503-8000

Fax: +1 (408) 503-8008

Email: marketing@supermicro.com (General Information)
support@supermicro.com (Technical Support)

Web Site: www.supermicro.com

Europe

Address: Super Micro Computer B.V.
Het Sterrenbeeld 28, 5215 ML
's-Hertogenbosch, The Netherlands

Tel: +31 (0) 73-6400390

Fax: +31 (0) 73-6416525

Email: sales@supermicro.nl (General Information)
support@supermicro.nl (Technical Support)
rma@supermicro.nl (Customer Support)

Asia-Pacific

Address: Super Micro Computer, Inc.
3F, No. 150, Jian 1st Rd.
Zhonghe Dist., New Taipei City 23511
Taiwan (R.O.C)

Tel: +886-(2) 8226-3990

Fax: +886-(2) 8226-3992

Web Site: www.supermicro.com.tw

Technical Support:

Email: support@supermicro.com.tw

Tel: +886-(2)-8226-3990

Chapter 2

Server Installation

2-1 Overview

This chapter provides a quick setup checklist to get your 8016B-6F/8016B-TF up and running. Following these steps in the order given should enable you to have the system operational within a minimum amount of time. This quick setup assumes that your system has come to you with the processors and memory preinstalled. If your system is not already fully integrated with a serverboard, processors, system memory etc., please turn to the chapter or section noted in each step for details on installing specific components.

2-2 Unpacking the System

You should inspect the box the 8016B-6F/8016B-TF was shipped in and note if it was damaged in any way. If the server itself shows damage you should file a damage claim with the carrier who delivered it.

Decide on a suitable location for the rack unit that will hold the 8016B-6F/8016B-TF. It should be situated in a clean, dust-free area that is well ventilated. Avoid areas where heat, electrical noise and electromagnetic fields are generated. You will also need it placed near a grounded power outlet. Be sure to read the Rack and Server Precautions in the next section.

2-3 Preparing for Setup

The box the 8016B-6F/8016B-TF was shipped in should include two sets of rail assemblies, two rail mounting brackets and the mounting screws you will need to install the system into the rack. Follow the steps in the order given to complete the installation process in a minimum amount of time. Please read this section in its entirety before you begin the installation procedure outlined in the sections that follow.

Choosing a Setup Location

- Leave enough clearance in front of the rack to enable you to open the front door completely (~25 inches) and approximately 30 inches of clearance in the back of the rack to allow for sufficient airflow and ease in servicing.

- This product is for installation only in a Restricted Access Location (dedicated equipment rooms, service closets and the like).
- This product is not suitable for use with visual display work place devices according to §2 of the the German Ordinance for Work with Visual Display Units.

2-4 Warnings and Precautions

Rack Precautions

- Ensure that the leveling jacks on the bottom of the rack are fully extended to the floor with the full weight of the rack resting on them.
- In single rack installation, stabilizers should be attached to the rack. In multiple rack installations, the racks should be coupled together.
- Always make sure the rack is stable before extending a component from the rack.
- You should extend only one component at a time - extending two or more simultaneously may cause the rack to become unstable.

Server Precautions

- Review the electrical and general safety precautions in Chapter 4.
- Determine the placement of each component in the rack *before* you install the rails.
- Install the heaviest server components on the bottom of the rack first, and then work up.
- Use a regulating uninterruptible power supply (UPS) to protect the server from power surges, voltage spikes and to keep your system operating in case of a power failure.
- Allow the hot plug SAS/SATA drives and power supply modules to cool before touching them.
- Always keep the rack's front door and all panels and components on the servers closed when not servicing to maintain proper cooling.

Rack Mounting Considerations

Ambient Operating Temperature

If installed in a closed or multi-unit rack assembly, the ambient operating temperature of the rack environment may be greater than the ambient temperature of the room. Therefore, consideration should be given to installing the equipment in an environment compatible with the manufacturer's maximum rated ambient temperature (T_{mra}).

Reduced Airflow

Equipment should be mounted into a rack so that the amount of airflow required for safe operation is not compromised.

Mechanical Loading

Equipment should be mounted into a rack so that a hazardous condition does not arise due to uneven mechanical loading.

Circuit Overloading

Consideration should be given to the connection of the equipment to the power supply circuitry and the effect that any possible overloading of circuits might have on overcurrent protection and power supply wiring. Appropriate consideration of equipment nameplate ratings should be used when addressing this concern.

Reliable Ground

A reliable ground must be maintained at all times. To ensure this, the rack itself should be grounded. Particular attention should be given to power supply connections other than the direct connections to the branch circuit (i.e. the use of power strips, etc.).



Warning! To prevent bodily injury when mounting or servicing this unit in a rack, you must take special precautions to ensure that the system remains stable. The following guidelines are provided to ensure your safety:

- This unit should be mounted at the bottom of the rack if it is the only unit in the rack.
- When mounting this unit in a partially filled rack, load the rack from the bottom to the top with the heaviest component at the bottom of the rack.
- If the rack is provided with stabilizing devices, install the stabilizers before mounting or servicing the unit in the rack.

2-5 Installing the System into a Rack

This section provides information on installing the 8016B-6F/8016B-TF into a rack unit with the rack rails provided. If the system has already been mounted into a rack, you can skip ahead to Sections 2-5 and 2-6. There are a variety of rack units on the market, which may mean the assembly procedure will differ slightly. You should also refer to the installation instructions that came with the rack unit you are using.

Identifying the Sections of the Rack Rails

You should have received two rack rail assemblies in the rack mounting kit. Each assembly consists of two sections: an inner fixed chassis rail that secures directly to the server chassis and an outer fixed rack rail that secures directly to the rack itself (see Figure 2-1). Two pairs of short brackets to be used on the front side of the outer rails are also included.

Installing the Inner Rails

Both the left and right side inner rails have been pre-attached to the chassis. Proceed to the next step.

Figure 2-1. Identifying the Sections of the Rack Rails (right side rail shown)

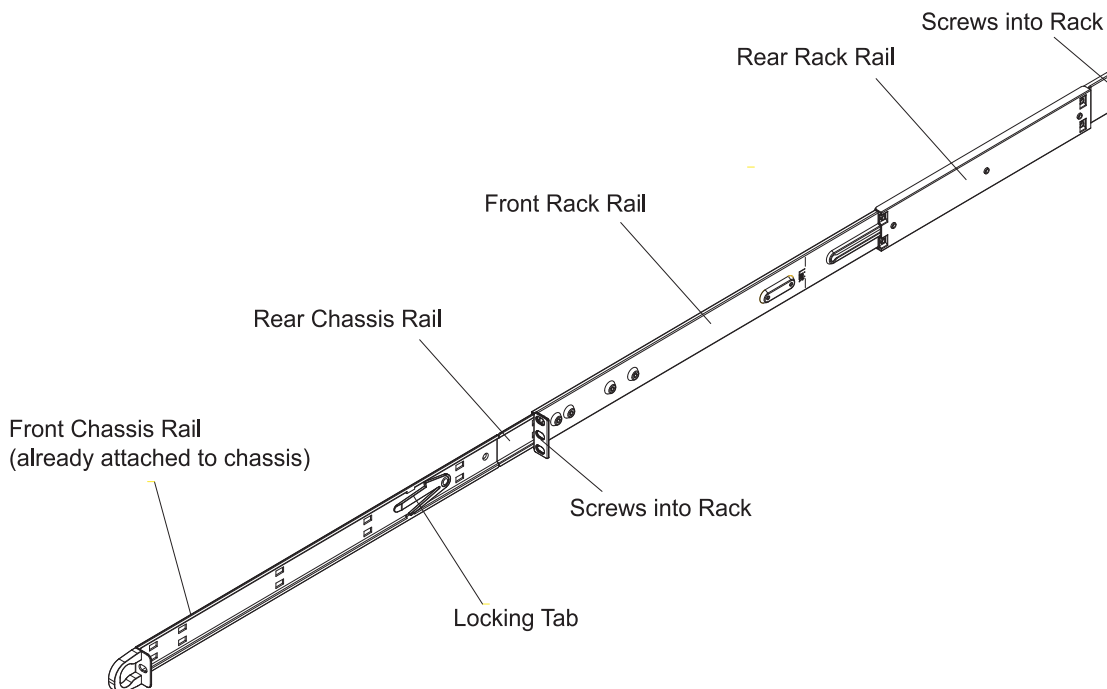

Warning: do not pick up the server with the front handles. They are designed to pull the system from a rack only.

Installing the Outer Rails

Begin by measuring the distance from the front rail to the rear rail of the rack. Attach a short bracket to the front side of the right outer rail and a long bracket to the rear side of the right outer rail. Adjust both the short and long brackets to the proper distance so that the rail can fit snugly into the rack. Secure the short bracket to the front side of the outer rail with two M4 screws and the long bracket to the rear side of the outer rail with three M4 screws. Repeat these steps for the left outer rail. See Figure 2-2.

Locking Tabs

Both chassis rails have a locking tab, which serves two functions. The first is to lock the server into place when installed and pushed fully into the rack, which is its normal position. Secondly, these tabs also lock the server in place when fully extended from the rack. This prevents the server from coming completely out of the rack when you pull it out for servicing.

Figure 2-2. Installing the Rack Rails

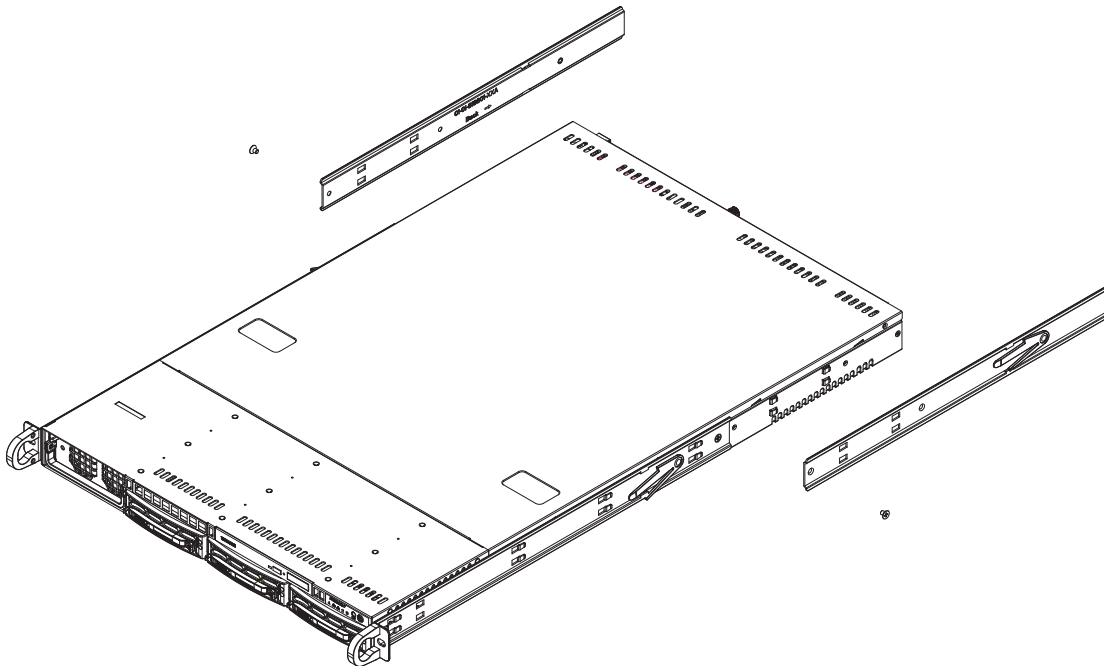

Warning: Stability hazard. The rack stabilizing mechanism must be in place, or the rack must be bolted to the floor before you slide the unit out for servicing. Failure to stabilize the rack can cause the rack to tip over.

Installing the Server into the Rack

You should now have rails attached to both the chassis and the rack unit. The next step is to install the server into the rack. Do this by lining up the rear of the chassis rails with the front of the rack rails. Slide the chassis rails into the rack rails, keeping the pressure even on both sides (you may have to depress the locking tabs when inserting). See Figure 2-3.

When the server has been pushed completely into the rack, you should hear the locking tabs "click". Finish by inserting and tightening the thumbscrews that hold the front of the server to the rack.

Figure 2-3. Installing the Server into a Rack

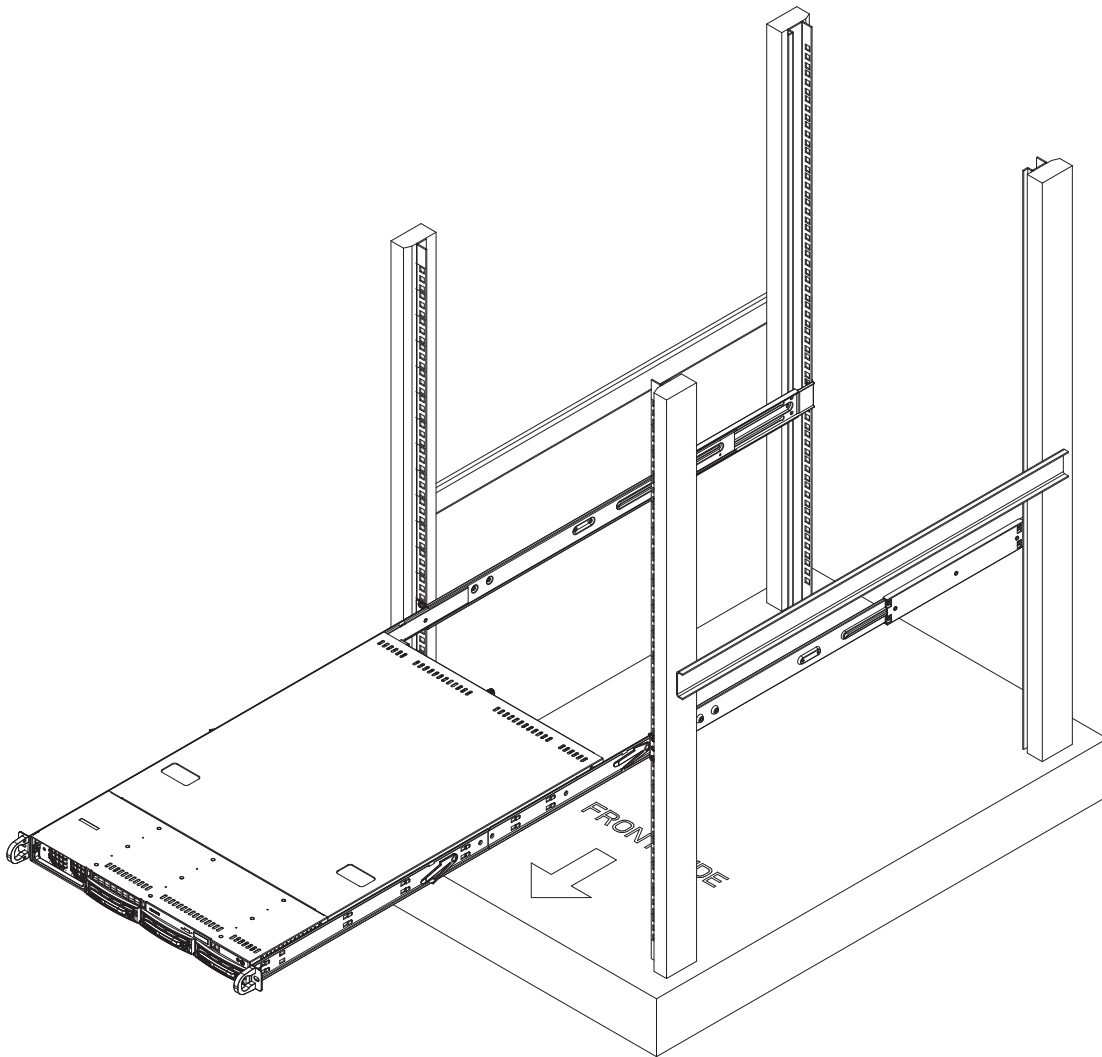

2-6 Checking the Serverboard Setup

After you install the 8016B-6F/8016B-TF in the rack, you will need to open the top cover to make sure the serverboard is properly installed and all the connections have been made.

Accessing the inside of the System (see Figure 2-4)

1. First, release the retention screws that secure the system to the rack.
2. Grasp the two handles on either side and pull the system straight out until it locks (you will hear a "click").
3. Next, release the thumbscrew at the middle rear of the top cover. Then depress the two buttons on the top of the chassis to release the top cover.
4. Push the cover away from you (toward the rear of the chassis) until it stops. You can then lift the top cover from the chassis to gain full access to the inside of the server.
5. To remove the system from the rack completely, depress the locking tabs in the chassis rails (push the right-side tab down and the left-side tab up) to continue to pull the system out past the locked position.

Checking the Components and Setup

1. You may up to four processors already installed in the serverboard. Each processor needs its own heatsink. See Chapter 5 for instructions on processor and heatsink installation.
2. Your server system may have come with system memory already installed. Make sure all DIMMs are fully seated in their slots. For details on adding system memory, refer to Chapter 5.
3. If desired, you can install an add-on card to the system. See Chapter 5 for details on installing PCI add-on cards.
4. Make sure all power and data cables are properly connected and not blocking the chassis airflow. See Chapter 5 for details on cable connections.

Figure 2-4. Accessing the Inside of the System

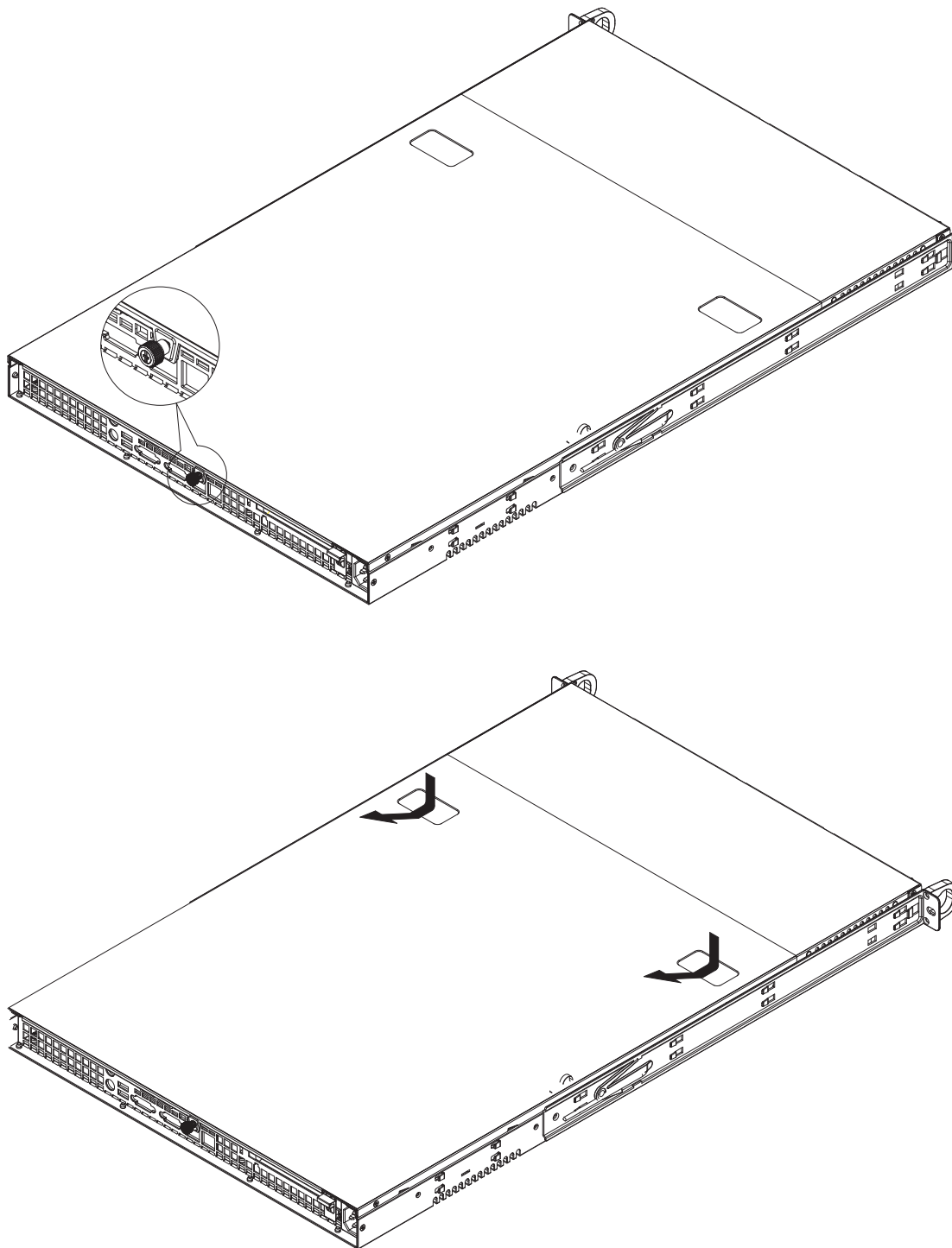

2-7 Preparing to Power On

Next, you should check to make sure the peripheral drives and the SAS/SATA drives and backplane have been properly installed and all connections have been made.

Checking the Drives

1. All drives are accessible from the front of the server. For servicing the DVD-ROM and floppy drives, you will need to remove the top chassis cover. The SAS/SATA disk drives can be installed and removed from the front of the chassis without removing the top chassis cover.
2. A slim DVD-ROM and floppy drive should be preinstalled in your server. Refer to Chapter 6 if you need to reinstall a DVD-ROM and/or floppy disk drive to the system.
3. Depending upon your system's configuration, your system may have one or more drives already installed. If you need to install SAS/SATA drives, please refer to Chapter 6.

Checking the Airflow

1. Airflow is provided by six sets of 4-cm fans (each set of fans consists of two fans that are mounted back to back) and an air shroud. The system component layout was carefully designed to direct sufficient cooling airflow to the components that generate the most heat.
2. Note that all power and data cables have been routed in such a way that they do not block the airflow generated by the fans.

Providing Power

1. Plug the power cords from the power supplies unit into a high-quality power strip that offers protection from electrical noise and power surges.
2. It is recommended that you use an uninterruptible power supply (UPS).
3. Finally, press the power on button on the front of the chassis.

Notes

Chapter 3

System Interface

3-1 Overview

There are several LEDs on the control panel as well as others on the drive carriers to keep you constantly informed of the overall status of the system as well as the activity and health of specific components. There are also two buttons on the chassis control panel and an on/off switch on the power supply. This chapter explains the meanings of all LED indicators and the appropriate response you may need to take.

3-2 Control Panel Buttons

There are two push-buttons located on the front of the chassis: a reset button and a power on/off button.

RESET

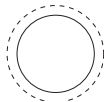

Reset

Use the reset button to reboot the system.

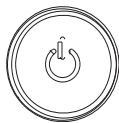

Power

The main power button is used to apply or remove power from the power supply to the server system. Turning off system power with this button removes the main power but keeps standby power supplied to the system.

3-3 Control Panel LEDs

The control panel located on the front of the SC818A-1400B chassis has five LEDs. These LEDs provide you with critical information related to different parts of the system. This section explains what each LED indicates when illuminated and any corrective action you may need to take.



Overheat/Fan Fail

When this LED flashes it indicates a fan failure. When on continuously (on and not flashing) it indicates an overheat condition, which may be caused by cables obstructing the airflow in the system or the ambient room temperature being too warm. Check the routing of the cables and make sure all fans are present and operating normally. You should also check to make sure that the chassis covers are installed. Finally, verify that the heatsinks are installed properly (see Chapter 5). This LED will remain flashing or on as long as the overheat condition exists.



NIC2

Indicates network activity on GLAN2 when flashing .



NIC1

Indicates network activity on GLAN1 when flashing .



HDD

On the 8016B-6F/8016B-TF this light indicates SAS, SATA and/or DVD-ROM drive activity when flashing.



Power

Indicates power is being supplied to the system's power supply units. This LED should normally be illuminated when the system is operating.

3-4 Drive Carrier LEDs

- **Green:** Each drive carrier has a green LED. When illuminated, this green LED (on the front of the drive carrier) indicates drive activity. A connection to the backplane enables this LED to blink on and off when that particular drive is being accessed. Please refer to Chapter 6 for instructions on replacing failed drives.
- **Red:** The red LED to indicate a drive failure. If one of the drives fail, you should be notified by your system management software. Please refer to Chapter 6 for instructions on replacing failed drives.

Notes

Chapter 4

Standardized Warning Statements for AC Systems

4-1 About Standardized Warning Statements

The following statements are industry standard warnings, provided to warn the user of situations which have the potential for bodily injury. Should you have questions or experience difficulty, contact Supermicro's Technical Support department for assistance. Only certified technicians should attempt to install or configure components.

Read this appendix in its entirety before installing or configuring components in the Supermicro chassis.

These warnings may also be found on our web site at http://www.supermicro.com/about/policies/safety_information.cfm.

Warning Definition



Warning!

This warning symbol means danger. You are in a situation that could cause bodily injury. Before you work on any equipment, be aware of the hazards involved with electrical circuitry and be familiar with standard practices for preventing accidents.

警告の定義

この警告サインは危険を意味します。

人身事故につながる可能性がありますので、いずれの機器でも動作させる前に、

電気回路に含まれる危険性に注意して、標準的な事故防止策に精通して下さい。

此警告符号代表危險。

您正處於可能受到嚴重傷害的工作環境中。在您使用設備開始工作之前，必須充分意識到觸電的危險，並熟練掌握防止事故發生的標準工作程序。請根據每項警告結尾的聲明號碼找到此設備的安全性警告說明的翻譯文本。

此警告符號代表危險。

您正處於可能身體可能會受損傷的工作環境中。在您使用任何設備之前，請注意觸電的危險，並且要熟悉預防事故發生的標準工作程序。請依照每一注意事項後的號碼找到相關的翻譯說明內容。

Warnung

WICHTIGE SICHERHEITSHINWEISE

Dieses Warnsymbol bedeutet Gefahr. Sie befinden sich in einer Situation, die zu Verletzungen führen kann. Machen Sie sich vor der Arbeit mit Geräten mit den Gefahren elektrischer Schaltungen und den üblichen Verfahren zur Vorbeugung vor Unfällen vertraut. Suchen Sie mit der am Ende jeder Warnung angegebenen Anweisungsnummer nach der jeweiligen Übersetzung in den übersetzten Sicherheitshinweisen, die zusammen mit diesem Gerät ausgeliefert wurden.

BEWAHREN SIE DIESE HINWEISE GUT AUF.

INSTRUCCIONES IMPORTANTES DE SEGURIDAD

Este símbolo de aviso indica peligro. Existe riesgo para su integridad física. Antes de manipular cualquier equipo, considere los riesgos de la corriente eléctrica y familiarícese con los procedimientos estándar de prevención de accidentes. Al final de cada advertencia encontrará el número que le ayudará a encontrar el texto traducido en el apartado de traducciones que acompaña a este dispositivo.

GUARDE ESTAS INSTRUCCIONES.

IMPORTANTES INFORMATIONS DE SÉCURITÉ

Ce symbole d'avertissement indique un danger. Vous vous trouvez dans une situation pouvant entraîner des blessures ou des dommages corporels. Avant de travailler sur un équipement, soyez conscient des dangers liés aux circuits électriques et familiarisez-vous avec les procédures couramment utilisées pour éviter les accidents. Pour prendre connaissance des traductions des avertissements figurant dans les consignes de sécurité traduites qui accompagnent cet appareil, référez-vous au numéro de l'instruction situé à la fin de chaque avertissement.

CONSERVEZ CES INFORMATIONS.

תקנון הצהרות אזהרה

הצהרות הבאות הן אזהרות על פי תקני התעשייה, על מנת להזהיר את המשתמש מפני חבלה פיזית אפשרית. במידה ויש שאלות או היתקלות בבעיה כלשהי, יש ליצור קשר עם מחלקת תמיכה טכנית של סופרמיקרו. טכנאים מוסמכים בלבד רשאים להתקין או להגדיר את הרכיבים.

יש לקרוא את הנספח במלואו לפני התקנת או הגדרת הרכיבים במארזי סופרמיקרו.

تحذير! هذا الرمز يعني خطر انك في حالة يمكن أن تتسبب في اصابة جسدية .
قبل أن تعمل على أي معدات، كن على علم بالمخاطر الناجمة عن الدوائر
الكهربائية
وكن على دراية بالممارسات الوقائية لمنع وقوع أي حوادث
استخدم رقم البيان المنصوص في نهاية كل تحذير للعثور ترجمتها

안전을 위한 주의사항

경고!

이 경고 기호는 위험이 있음을 알려 줍니다. 작업자의 신체에 부상을 야기 할 수 있는 상태에 있게 됩니다. 모든 장비에 대한 작업을 수행하기 전에 전기회로와 관련된 위험요소들을 확인하시고 사전에 사고를 방지할 수 있도록 표준 작업절차를 준수해 주시기 바랍니다.

해당 번역문을 찾기 위해 각 경고의 마지막 부분에 제공된 경고문 번호를 참조하십시오

BELANGRIJKE VEILIGHEIDSINSTRUCTIES

Dit waarschuwings symbool betekent gevaar. U verkeert in een situatie die lichamelijk letsel kan veroorzaken. Voordat u aan enige apparatuur gaat werken, dient u zich bewust te zijn van de bij een elektrische installatie betrokken risico's en dient u op de hoogte te zijn van de standaard procedures om ongelukken te voorkomen. Gebruik de nummers aan het eind van elke waarschuwing om deze te herleiden naar de desbetreffende locatie.

BEWAAR DEZE INSTRUCTIES

Installation Instructions



Warning!

Read the installation instructions before connecting the system to the power source.

設置手順書

システムを電源に接続する前に、設置手順書をお読み下さい。

警告

将此系统连接电源前, 请先阅读安装说明。

警告

將系統與電源連接前，請先閱讀安裝說明。

Warnung

Vor dem Anschließen des Systems an die Stromquelle die Installationsanweisungen lesen.

¡Advertencia!

Lea las instrucciones de instalación antes de conectar el sistema a la red de alimentación.

Attention

Avant de brancher le système sur la source d'alimentation, consulter les directives d'installation.

יש לקרוא את הוראות התקנה לפני חיבור המערכת למקור מתח.

اقر إرشادات التركيب قبل توصيل النظام إلى مصدر للطاقة

시스템을 전원에 연결하기 전에 설치 안내를 읽어주십시오.

Waarschuwing

Raadpleeg de installatie-instructies voordat u het systeem op de voedingsbron aansluit.

Circuit Breaker



Warning!

This product relies on the building's installation for short-circuit (overcurrent) protection. Ensure that the protective device is rated not greater than: 250 V, 20 A.

サーキット・ブレーカー

この製品は、短絡(過電流)保護装置がある建物での設置を前提としています。

保護装置の定格が250 V、20 Aを超えないことを確認下さい。

警告

此产品的短路(过载电流)保护由建筑物的供电系统提供,确保短路保护设备的额定电流不大于250V,20A。

警告

此产品的短路(过载电流)保护由建筑物的供电系统提供,确保短路保护设备的额定电流不大于250V,20A。

Warnung

Dieses Produkt ist darauf angewiesen, dass im Gebäude ein Kurzschluss- bzw. Überstromschutz installiert ist. Stellen Sie sicher, dass der Nennwert der Schutzvorrichtung nicht mehr als: 250 V, 20 A beträgt.

¡Advertencia!

Este equipo utiliza el sistema de protección contra cortocircuitos (o sobrecorrientes) del edificio. Asegúrese de que el dispositivo de protección no sea superior a: 250 V, 20 A.

Attention

Pour ce qui est de la protection contre les courts-circuits (surtension), ce produit dépend de l'installation électrique du local. Vérifiez que le courant nominal du dispositif de protection n'est pas supérieur à :250 V, 20 A.

מוצר זה מסתמך על הגנה המותקנת במבנים למניעת קצר חשמלי. יש לוודא
המכשיר המגן מפני הקצר החשמלי הוא לא יותר מ-20A, 60VDC

هذا المنتج يعتمد على معدات الحماية التي توفرها لتأمينها ف
المبنى

تأكد من أن تقييم الجهاز الوقائي ليس أكثر من: 20A, 250VDC

경고!

이 제품은 전원의 단락(과전류)방지에 대해서 전적으로 건물의 관련 설비에 의존합니다. 보호장치의 정격이 반드시 250V(볼트), 20A(암페어)를 초과하지 않도록 해야 합니다.

Waarschuwing

Dit product is afhankelijk van de kortsluitbeveiliging (overspanning) van uw elektrische installatie. Controleer of het beveiligde apparaat niet groter gedimensioneerd is dan 220V, 20A.

Power Disconnection Warning



Warning!

The system must be disconnected from all sources of power and the power cord removed from the power supply module(s) before accessing the chassis interior to install or remove system components.

電源切断の警告

システムコンポーネントの取り付けまたは取り外しのために、シャーシー内部にアクセスするには、システムの電源はすべてのソースから切断され、電源コードは電源モジュールから取り外す必要があります。

警告

在你打开机箱并安装或移除内部器件前,必须将系统完全断电,并移除电源线。

警告

在您打開機殼安裝或移除內部元件前,必須將系統完全斷電,並移除電源線。

Warnung

Das System muss von allen Quellen der Energie und vom Netzanschlusskabel getrennt sein, das von den Spg.Versorgungsteilmodulen entfernt wird, bevor es auf den Chassisinnenraum zurückgreift, um Systemsbestandteile anzubringen oder zu entfernen.

¡Advertencia!

El sistema debe ser disconnected de todas las fuentes de energía y del cable eléctrico quitado de los módulos de fuente de alimentación antes de tener acceso el interior del chasis para instalar o para quitar componentes de sistema.

Attention

Le système doit être débranché de toutes les sources de puissance ainsi que de son cordon d'alimentation secteur avant d'accéder à l'intérieur du châssis pour installer ou enlever des composants de système.

אזהרה!

יש לנתק את המערכת מכל מקורות החשמל ויש להסיר את כבל החשמלי מהספק לפני גישה לחלק הפנימי של המארז לצורך התקנת או הסרת רכיבים.

يجب فصل النظام من جميع مصادر الطاقة وإزالة سلك الكهرباء من وحدة امداد الطاقة قبل الوصول إلى المناطق الداخلية للهيكल لتثبيت أو إزالة مكونات الجهاز

경고!

시스템에 부품들을 장착하거나 제거하기 위해서는 새시 내부에 접근하기 전에 반드시 전원 공급장치로부터 연결되어있는 모든 전원과 전기코드를 분리해주어야 합니다.

Waarschuwing

Voordat u toegang neemt tot het binnenwerk van de behuizing voor het installeren of verwijderen van systeem onderdelen, dient u alle spanningsbronnen en alle stroomkabels aangesloten op de voeding(en) van de behuizing te verwijderen

Equipment Installation



Warning!

Only trained and qualified personnel should be allowed to install, replace, or service this equipment.

機器の設置

トレーニングを受け認定された人だけがこの装置の設置、交換、またはサービスを許可されています。

警告

只有经过培训且具有资格的人员才能进行此设备的安装、更换和维修。

警告

只有經過受訓且具資格人員才可安裝、更換與維修此設備。

Warnung

Das Installieren, Ersetzen oder Bedienen dieser Ausrüstung sollte nur geschultem, qualifiziertem Personal gestattet werden.

¡Advertencia!

Solamente el personal calificado debe instalar, reemplazar o utilizar este equipo.

Attention

Il est vivement recommandé de confier l'installation, le remplacement et la maintenance de ces équipements à des personnels qualifiés et expérimentés.

אזהרה!

צוות מוסמך בלבד רשאי להתקין, להחליף את הציוד או לתת שירות עבור הציוד.

يجب أن يسمح فقط للموظفين المؤهلين والمدربين لتثبيت واستبدال أو خدمة هذا الجهاز

경고!

훈련을 받고 공인된 기술자만이 이 장비의 설치, 교체 또는 서비스를 수행할 수 있습니다.

Waarschuwing

Deze apparatuur mag alleen worden geïnstalleerd, vervangen of hersteld door geschoold en gekwalificeerd personeel.

Restricted Area



Warning!

This unit is intended for installation in restricted access areas. A restricted access area can be accessed only through the use of a special tool, lock and key, or other means of security. (This warning does not apply to workstations).

アクセス制限区域

このユニットは、アクセス制限区域に設置されることを想定しています。

アクセス制限区域は、特別なツール、鍵と錠前、その他のセキュリティの手段を用いてのみ出入りが可能です。

警告

此部件应安装在限制进出的场所，限制进出的场所指只能通过使用特殊工具、锁和钥匙或其它安全手段进出的场所。

警告

此装置仅限安装於進出管制區域，進出管制區域係指僅能以特殊工具、鎖頭及鑰匙或其他安全方式才能進入的區域。

Warnung

Diese Einheit ist zur Installation in Bereichen mit beschränktem Zutritt vorgesehen. Der Zutritt zu derartigen Bereichen ist nur mit einem Spezialwerkzeug, Schloss und Schlüssel oder einer sonstigen Sicherheitsvorkehrung möglich.

¡Advertencia!

Esta unidad ha sido diseñada para instalación en áreas de acceso restringido. Sólo puede obtenerse acceso a una de estas áreas mediante la utilización de una herramienta especial, cerradura con llave u otro medio de seguridad.

Attention

Cet appareil doit être installée dans des zones d'accès réservés. L'accès à une zone d'accès réservé n'est possible qu'en utilisant un outil spécial, un mécanisme de verrouillage et une clé, ou tout autre moyen de sécurité.

אזור עם גישה מוגבלת

אזהרה!

יש להתקין את היחידה באזורים שיש בהם הגבלת גישה. הגישה ניתנת בעזרת כלי אבטחה בלבד (מפתח, מנעול וכד').

تم تخصيص هذه الوحدة لتركيبها في مناطق محظورة .
يمكن الوصول إلى منطقة محظورة فقط من خلال استخدام أداة خاصة،
قفل ومفتاح أو أي وسيلة أخرى للأمان

경고!

이 장치는 접근이 제한된 구역에 설치하도록 되어있습니다. 특수도구, 잠금 장치 및 키, 또는 기타 보안 수단을 통해서만 접근 제한 구역에 들어갈 수 있습니다.

Waarschuwing

Dit apparaat is bedoeld voor installatie in gebieden met een beperkte toegang. Toegang tot dergelijke gebieden kunnen alleen verkregen worden door gebruik te maken van speciaal gereedschap, slot en sleutel of andere veiligheidsmaatregelen.

Battery Handling



Warning!

There is the danger of explosion if the battery is replaced incorrectly. Replace the battery only with the same or equivalent type recommended by the manufacturer. Dispose of used batteries according to the manufacturer's instructions

電池の取り扱い

電池交換が正しく行われなかった場合、破裂の危険性があります。交換する電池はメーカーが推奨する型、または同等のものを使用下さい。使用済電池は製造元の指示に従って処分して下さい。

警告

電池更換不當會有爆炸危險。請只使用同類電池或製造商推薦的功能相當的電池更換原有電池。請按製造商的說明處理廢舊電池。

警告

電池更換不當會有爆炸危險。請使用製造商建議之相同或功能相當的電池更換原有電池。請按照製造商的說明指示處理廢棄舊電池。

Warnung

Bei Einsetzen einer falschen Batterie besteht Explosionsgefahr. Ersetzen Sie die Batterie nur durch den gleichen oder vom Hersteller empfohlenen Batterietyp. Entsorgen Sie die benutzten Batterien nach den Anweisungen des Herstellers.

Attention

Danger d'explosion si la pile n'est pas remplacée correctement. Ne la remplacer que par une pile de type semblable ou équivalent, recommandée par le fabricant. Jeter les piles usagées conformément aux instructions du fabricant.

¡Advertencia!

Existe peligro de explosión si la batería se reemplaza de manera incorrecta. Reemplazar la batería exclusivamente con el mismo tipo o el equivalente recomendado por el fabricante. Desechar las baterías gastadas según las instrucciones del fabricante.

אזהרה!

קיימת סכנת פיצוץ של הסוללה במידה והוחלפה בדרך לא תקינה. יש להחליף את הסוללה בסוג התואם מחברת יצרן מומלצת.

סילוק הסוללות המשומשות יש לבצע לפי הוראות היצרן.

هناك خطر من انفجار في حالة استبدال البطارية بطريقة غير صحيحة فعليك استبدال البطارية فقط بنفس النوع أو ما يعادلها كما أوصت به الشركة المصنعة تخلص من البطاريات المستعملة وفقا لتعليمات الشركة الصانعة

경고!

배터리가 올바르게 교체되지 않으면 폭발의 위험이 있습니다. 기존 배터리와 동일하거나 제조사에서 권장하는 동등한 종류의 배터리로만 교체해야 합니다. 제조사의 안내에 따라 사용된 배터리를 처리하여 주십시오.

Waarschuwing

Er is ontploffingsgevaar indien de batterij verkeerd vervangen wordt. Vervang de batterij slechts met hetzelfde of een equivalent type die door de fabrikant aanbevolen wordt. Gebruikte batterijen dienen overeenkomstig fabrieksvoorschriften afgevoerd te worden.

Redundant Power Supplies



Warning!

This unit might have more than one power supply connection. All connections must be removed to de-energize the unit.

冗長電源装置

このユニットは複数の電源装置が接続されている場合があります。
ユニットの電源を切るためには、すべての接続を取り外さなければなりません。

警告

此部件连接的电源可能不止一个，必须将所有电源断开才能停止给该部件供电。

警告

此裝置連接的電源可能不只一個，必須切斷所有電源才能停止對該裝置的供電。

Warnung

Dieses Gerät kann mehr als eine Stromzufuhr haben. Um sicherzustellen, dass der Einheit kein Strom zugeführt wird, müssen alle Verbindungen entfernt werden.

¡Advertencia!

Puede que esta unidad tenga más de una conexión para fuentes de alimentación. Para cortar por completo el suministro de energía, deben desconectarse todas las conexiones.

Attention

Cette unité peut avoir plus d'une connexion d'alimentation. Pour supprimer toute tension et tout courant électrique de l'unité, toutes les connexions d'alimentation doivent être débranchées.

אם קיים יותר מספק אחד

אזהרה!

ליחידה יש יותר מחיבור אחד של ספק. יש להסיר את כל החיבורים על מנת לרוקן את היחידה.

قد يكون لهذا الجهاز عدة اتصالات بوحدات امداد الطاقة.
يجب إزالة كافة الاتصالات لعزل الوحدة عن الكهرباء

경고!

이 장치에는 한 개 이상의 전원 공급 단자가 연결되어 있을 수 있습니다. 이 장치에 전원을 차단하기 위해서는 모든 연결 단자를 제거해야만 합니다.

Waarschuwing

Deze eenheid kan meer dan één stroomtoevoeraansluiting bevatten. Alle aansluitingen dienen verwijderd te worden om het apparaat stroomloos te maken.

Backplane Voltage



Warning!

Hazardous voltage or energy is present on the backplane when the system is operating. Use caution when servicing.

バックプレーンの電圧

システム稼働中は危険な電圧または電力が、バックプレーン上にかかっています。

修理する際にはご注意ください。

警告

当系统正在进行时，背板上有很危险的电压或能量，进行维修时务必小心。

警告

當系統正在進行時，背板上危險的電壓或能量，進行維修時務必小心。

Warnung

Wenn das System in Betrieb ist, treten auf der Rückwandplatine gefährliche Spannungen oder Energien auf. Vorsicht bei der Wartung.

¡Advertencia!

Cuando el sistema está en funcionamiento, el voltaje del plano trasero es peligroso. Tenga cuidado cuando lo revise.

Attention

Lorsque le système est en fonctionnement, des tensions électriques circulent sur le fond de panier. Prendre des précautions lors de la maintenance.

מתח בפנל האחורי

אזהרה!
קיימת סכנת מתח בפנל האחורי בזמן תפעול המערכת. יש להיזהר במהלך העבודה.

هناك خطر من التيار الكهربائي أو الطاقة الموجودة على اللوحة
عندما يكون النظام يعمل كن حذرا عند خدمة هذا الجهاز

경고!

시스템이 동작 중일 때 후면판 (Backplane)에는 위험한 전압이나 에너지가 발생합니다. 서비스 작업 시 주의하십시오.

Waarschuwing

Een gevaarlijke spanning of energie is aanwezig op de backplane wanneer het systeem in gebruik is. Voorzichtigheid is geboden tijdens het onderhoud.

Comply with Local and National Electrical Codes



Warning!

Installation of the equipment must comply with local and national electrical codes.

地方および国の電気規格に準拠

機器の取り付けはその地方および国の電気規格に準拠する必要があります。

警告

设备安装必须符合本地与本国电气法规。

警告

設備安裝必須符合本地與本國電氣法規。

Warnung

Die Installation der Geräte muss den Sicherheitsstandards entsprechen.

¡Advertencia!

La instalación del equipo debe cumplir con las normas de electricidad locales y nacionales.

Attention

L'équipement doit être installé conformément aux normes électriques nationales et locales.

תיאום חוקי החשמל הארצי

אזהרה!

התקנת הציוד חייבת להיות תואמת לחוקי החשמל המקומיים והארציים.

تركيب المعدات الكهربائية يجب أن يمتثل للقوانين المحلية والوطنية المتعلقة بالكهرباء

경고!

현 지역 및 국가의 전기 규정에 따라 장비를 설치해야 합니다.

Waarschuwing

Bij installatie van de apparatuur moet worden voldaan aan de lokale en nationale elektriciteitsvoorschriften.

Product Disposal



Warning!

Ultimate disposal of this product should be handled according to all national laws and regulations.

製品の廃棄

この製品を廃棄処分する場合、国の関係する全ての法律・条例に従い処理する必要があります。

警告

本产品的废弃处理应根据所有国家的法律和规章进行。

警告

本產品的廢棄處理應根據所有國家的法律和規章進行。

Warnung

Die Entsorgung dieses Produkts sollte gemäß allen Bestimmungen und Gesetzen des Landes erfolgen.

¡Advertencia!

Al deshacerse por completo de este producto debe seguir todas las leyes y reglamentos nacionales.

Attention

La mise au rebut ou le recyclage de ce produit sont généralement soumis à des lois et/ou directives de respect de l'environnement. Renseignez-vous auprès de l'organisme compétent.

סילוק המוצר

אזהרה!

סילוק סופי של מוצר זה חייב להיות בהתאם להנחיות וחוקי המדינה.

عند التخلص النهائي من هذا المنتج ينبغي التعامل معه وفقا لجميع القوانين واللوائح الوطنية

경고!

이 제품은 해당 국가의 관련 법규 및 규정에 따라 폐기되어야 합니다.

Waarschuwing

De uiteindelijke verwijdering van dit product dient te geschieden in overeenstemming met alle nationale wetten en reglementen.

Hot Swap Fan Warning



Warning!

The fans might still be turning when you remove the fan assembly from the chassis. Keep fingers, screwdrivers, and other objects away from the openings in the fan assembly's housing.

ファン・ホットスワップの警告

シャーシから冷却ファン装置を取り外した際、ファンがまだ回転している可能性があります。ファンの開口部に、指、ドライバー、およびその他のものを近づけないで下さい。

警告

当您从机架移除风扇装置，风扇可能仍在转动。小心不要将手指、螺丝起子和其他物品太靠近风扇

警告

當您從機架移除風扇裝置，風扇可能仍在轉動。小心不要將手指、螺絲起子和其他物品太靠近風扇。

Warnung

Die Lüfter drehen sich u. U. noch, wenn die Lüfterbaugruppe aus dem Chassis genommen wird. Halten Sie Finger, Schraubendreher und andere Gegenstände von den Öffnungen des Lüftergehäuses entfernt.

¡Advertencia!

Los ventiladores podran dar vuelta cuando usted quite ell montaje del ventilador del chasis. Mandtenga los dedos, los destornilladores y todos los objetos lejos de las aberturas del ventilador

Attention

Il est possible que les ventilateurs soient toujours en rotation lorsque vous retirerez le bloc ventilateur du châssis. Prenez garde à ce que doigts, tournevis et autres objets soient éloignés du logement du bloc ventilateur.

אזהרה !

כאשר מסירים את חלקי המאוורר מהמארז, יתכן והמאווררים עדיין עובדים. יש להרחיק למרחק בטוח את האצבעות וכלי עבודה שונים מהפתחים בתוך המאוורר

من الممكن أن المراوح لا تزال تدور عند إزالة كتلة المروحة من الهيكل يجب إبقاء الأصابع ومفكات البراغي وغيرها من الأشياء بعيدا عن الفتحات في كتلة المروحة.

경고!

새시로부터 팬 조립품을 제거할 때 팬은 여전히 회전하고 있을 수 있습니다. 팬 조립품 외관의 열려있는 부분들로부터 손가락 및 스크류드라이버, 다른 물체들이 가까이 하지 않도록 배치해 주십시오.

Waarschuwing

Het is mogelijk dat de ventilator nog draait tijdens het verwijderen van het ventilatorsamenstel uit het chassis. Houd uw vingers, schroevendraaiers en eventuele andere voorwerpen uit de buurt van de openingen in de ventilatorbehuizing.

Power Cable and AC Adapter



Warning!

When installing the product, use the provided or designated connection cables, power cables and AC adaptors. Using any other cables and adaptors could cause a malfunction or a fire. Electrical Appliance and Material Safety Law prohibits the use of UL or CSA -certified cables (that have UL/CSA shown on the code) for any other electrical devices than products designated by Supermicro only.

電源コードとACアダプター

製品を設置する場合、提供または指定された接続ケーブル、電源コードとACアダプターを使用下さい。他のケーブルやアダプタを使用すると故障や火災の原因になることがあります。電気用品安全法は、ULまたはCSA認定のケーブル(UL/CSEマークがコードに表記)を Supermicroが指定する製品以外に使用することを禁止しています。

警告

安裝此產品時，請使用本身提供的或指定的連接線，電源線和電源適配器。使用其它線材或適配器可能會引起故障或火災。除了 Supermicro 所指定的產品，電氣用品和材料安全法律規定禁止使用未經 UL 或 CSA 認證的線材。(線材上會顯示 UL/CSA 符號)。

警告

安裝此產品時，請使用本身提供的或指定的連接線，電源線和電源適配器。使用其它線材或適配器可能會引起故障或火災。除了 Supermicro 所指定的產品，電氣用品和材料安全法律規定禁止使用未經 UL 或 CSA 認證的線材。(線材上會顯示 UL/CSA 符號)。

Warnung

Bei der Installation des Produkts, die zur Verfügung gestellten oder benannt Anschlusskabel, Stromkabel und Netzteile. Verwendung anderer Kabel und Adapter kann zu einer Fehlfunktion oder ein Brand entstehen. Elektrische Geräte und Material Safety Law verbietet die Verwendung von UL-oder CSA-zertifizierte Kabel, UL oder CSA auf der Code für alle anderen elektrischen Geräte als Produkte von Supermicro nur bezeichnet gezeigt haben.

¡Advertencia!

Al instalar el producto, utilice los cables de conexión previstos o designados, los cables y adaptadores de CA. La utilización de otros cables y adaptadores podría ocasionar un mal funcionamiento o un incendio. Aparatos Eléctricos y la Ley de Seguridad del Material prohíbe el uso de UL o CSA cables certificados que tienen UL o CSA se muestra en el código de otros dispositivos eléctricos que los productos designados por Supermicro solamente.

Attention

Lors de l'installation du produit, utilisez les bables de connection fournis ou désigné. L'utilisation d'autres cables et adaptateurs peut provoquer un dysfonctionnement ou un incendie. Appareils électroménagers et de loi sur la sécurité Matériel interdit l'utilisation de UL ou CSA câbles certifiés qui ont UL ou CSA indiqué sur le code pour tous les autres appareils électriques que les produits désignés par Supermicro seulement.

חשמליים ומתאמי AC

אזהרה!

כאשר מתקינים את המוצר, יש להשתמש בכבלים, ספקים ומתאמים AC אשר נועדו וסופקו לשם כך. שימוש בכל כבל או מתאם אחר יכול לגרום לתקלה או קצר חשמלי. על פי חוקי שימוש במכשירי חשמל וחוקי בטיחות, קיים איסור להשתמש בכבלים המוסמכים ב- UL או ב- CSA (כשאר מופיע עליהם קוד של UL/CSA) עבור כל מוצר חשמלי אחר שלא צוין על ידי סופרקמיקרו בלבד.

عند تركيب الجهاز يجب استخدام كابلات التوصيل، والكابلات الكهربائية ومحولات التيار المتردد التي . أن استخدام أي كابلات ومحولات أخرى يتسبب في حدوث عطل أو حريق. تم توفيرها لك مع المنتج الأجهزة الكهربائية ومواد قانون السلامة يحظر استخدام الكابلات UL أو CSA معتمدة من قبل لأي أجهزة كهربائية أخرى غير المنتجات المعينة من قبل Supermicro (التي تحمل علامة UL/CSA)

경고!

제품을 설치할 때에는 제공되거나 지정된 연결케이블과 전원케이블, AC어댑터를 사용해야 합니다. 그 밖의 다른 케이블들이나 어댑터들은 고장 또는 화재의 원인이 될 수 있습니다. 전기용품안전법 (Electrical Appliance and Material Safety Law)은 슈퍼마이크로에서 지정한 제품들 외에는 그 밖의 다른 전기 장치들을 위한 UL 또는 CSA에서 인증한 케이블(전선 위에 UL/CSA가 표시)들의 사용을 금지합니다.

Waarschuwing

Bij het installeren van het product, gebruik de meegeleverde of aangewezen kabels, stroomkabels en adapters. Het gebruik van andere kabels en adapters kan leiden tot een storing of een brand. Elektrisch apparaat en veiligheidsinformatiebladen wet verbiedt het gebruik van UL of CSA gecertificeerde kabels die UL of CSA die op de code voor andere elektrische apparaten dan de producten die door Supermicro alleen.

Notes

Chapter 5

Advanced Serverboard Setup

This chapter covers the steps required to install the X8QB6-F/X8QBE-F serverboard into the chassis, connect the data and power cables and install add-on cards. All serverboard jumpers and connections are also described. A layout and quick reference chart are included in this chapter for your reference. Remember to completely close the chassis when you have finished working with the serverboard to better cool and protect the system.

5-1 Handling the Serverboard

Electrostatic Discharge (ESD) can damage electronic components. To prevent damage to any printed circuit boards (PCBs), it is important to handle them very carefully (see previous chapter). To prevent the serverboard from bending, keep one hand under the center of the board to support it when handling. The following measures are generally sufficient to protect your equipment from electric static discharge.

Precautions

- Use a grounded wrist strap designed to prevent Electrostatic Discharge (ESD).
- Touch a grounded metal object before removing any board from its antistatic bag.
- Handle a board by its edges only; do not touch its components, peripheral chips, memory modules or gold contacts.
- When handling chips or modules, avoid touching their pins.
- Put the serverboard, add-on cards and peripherals back into their antistatic bags when not in use.
- For grounding purposes, make sure your computer chassis provides excellent conductivity between the power supply, the case, the mounting fasteners and the serverboard.

Unpacking

The serverboard is shipped in antistatic packaging to avoid electrical static discharge. When unpacking the board, make sure the person handling it is static protected.

5-2 Serverboard Installation

This section explains the first step of physically mounting the X8QB6-F/X8QBE-F into the SC818TQ-1000 chassis. Following the steps in the order given will eliminate the most common problems encountered in such an installation. To remove the serverboard, follow the procedure in reverse order.

Installing to the Chassis

1. Access the inside of the system by removing the screws from the back lip of the top cover of the chassis, then pull the cover off.
2. The X8QB6-F/X8QBE-F requires a chassis big enough to support a 16.4" x 16.8" serverboard, such as Supermicro's SC818A-1400B.
3. Make sure that the I/O ports on the serverboard align properly with their respective holes in the I/O shield at the back of the chassis.
4. Carefully mount the serverboard to the serverboard tray by aligning the board holes with the raised metal standoffs that are visible in the chassis.
5. Insert screws into all the mounting holes on your serverboard that line up with the standoffs and tighten until snug (if you screw them in too tight, you might strip the threads). Metal screws provide an electrical contact to the serverboard ground to provide a continuous ground for the system.
6. Finish by replacing the top cover of the chassis.

Warning: To avoid damaging the motherboard and its components, do not apply force greater than 8 lbs. per square inch when installing a screw into a mounting hole.

5-3 Connecting Cables

Now that the serverboard is installed, the next step is to connect the cables to the board. These include the data (ribbon) cables for the peripherals and control panel and the power cables.

Connecting Data Cables

The ribbon cables used to transfer data from the peripheral devices have been carefully routed to prevent them from blocking the flow of cooling air that moves through the system from front to back. If you need to disconnect any of these cables, you should take care to keep them routed as they were originally after reconnecting them (make sure the red wires connect to the pin 1 locations). The following data cables (with their locations noted) should be connected. (See the layout on page 5-9 for connector locations.)

- 8016B-6F: SAS drive data cable (SAS0 ~ 2)
- 8016B-TF: SATA drive data cable (I-SATA0 ~ 2)
- Control Panel cable (JF1)
- DVD-ROM drive cable

Important! Make sure the the cables do not come into contact with the fans.

Connecting Power Cables

The X8QB6-F/X8QBE-F has a 24-pin primary power supply connector (JPW3) for connection to the ATX power supply. In addition, there are 8-pin secondary power connectors (JPW1-2 and JPW4-5) that also must be connected to your power supply. See Section 5-9 for power connector pin definitions.

Connecting the Control Panel

JF1 contains header pins for various front control panel connectors. See Figure 5-1 for the pin locations of the various front control panel buttons and LED indicators.

All JF1 wires have been bundled into a single ribbon cable to simplify this connection. Make sure the red wire plugs into pin 1 as marked on the board. The other end connects to the Control Panel PCB board, located just behind the system status LEDs on the chassis. See Chapter 5 for details and pin descriptions.

Figure 5-1. Control Panel Header Pins

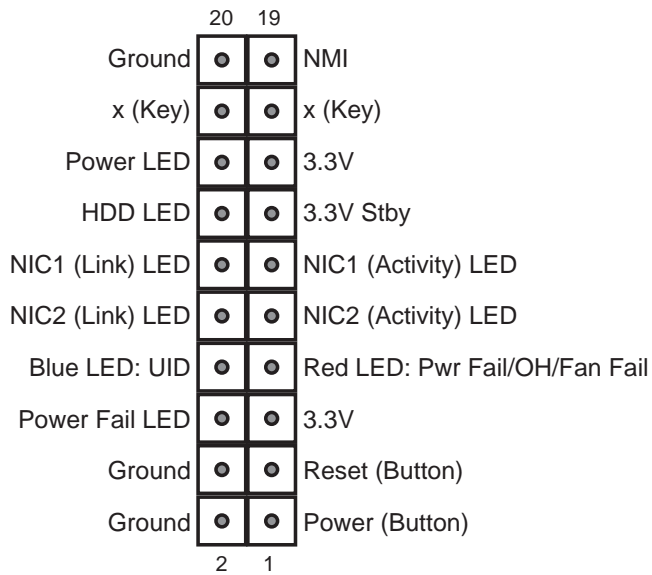

5-4 I/O Ports

The I/O ports are color coded in conformance with the PC 99 specification. See Figure 5-2 below for the colors and locations of the various I/O ports.

Figure 5-2. I/O Ports

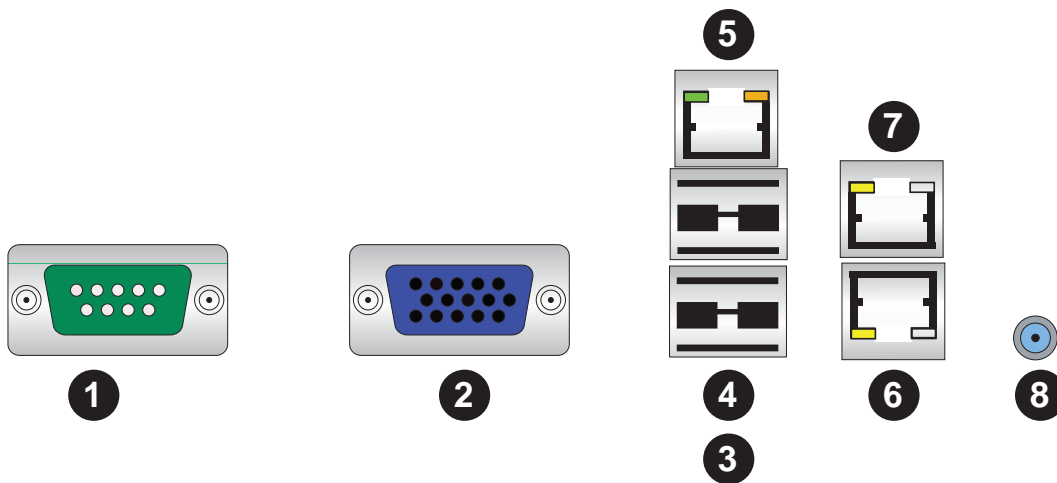

I/O Ports			
1	Serial (COM) Port	5	Dedicated IPMI LAN Port
2	VGA Port	6	LAN Port 1
3	USB0 Port	7	LAN Port 2
4	USB1 Port	8	UID Switch

5-5 Installing the Processor and Heatsink

Warning: Avoid placing direct pressure to the top of the processor package. Always remove the power cord first before adding, removing or changing any hardware components.

Notes:

- Always connect the power cord last and always remove it before adding, removing or changing any hardware components. Make sure that you install the processor into the CPU socket before you install the CPU heatsink.
- If you buy a CPU separately, make sure that you use an Intel-certified multi-directional heatsink only.
- Make sure to install the serverboard into the chassis before you install the CPU heatsinks.
- When receiving a serverboard without a processor pre-installed, make sure that the plastic CPU socket cap is in place and none of the socket pins are bent; otherwise, contact your retailer immediately.
- Refer to the Supermicro web site for updates on CPU support.

Installation Procedure

1. Press the socket clip to release the load plate, which covers the CPU socket, from its locking position.
2. Gently lift the socket clip to open the load plate.
3. Hold the plastic cap at its north and south center edges to remove it from the CPU socket.
4. After removing the plastic cap, using your thumb and the index finger, hold the CPU at the north and south center edges.

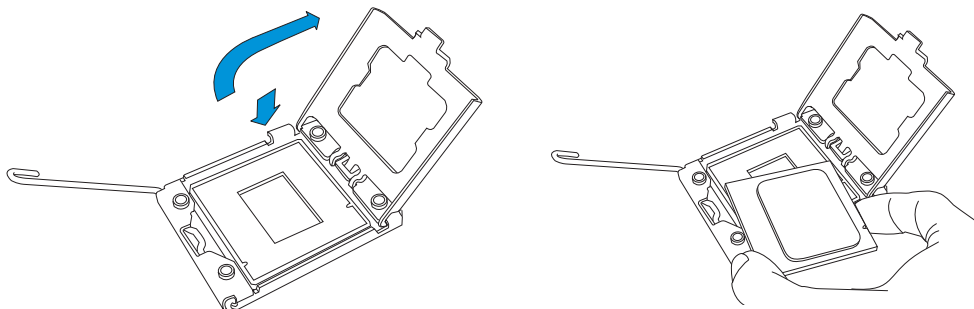

Warning: Make sure you lift the lever completely when installing the CPU; otherwise, damage to the socket or CPU may occur.

5. Align the CPU key (a semi-circle cutout) against the socket key, which is the notch below the gold color dot on the side of the socket.
6. Align pin 1 on the CPU with pin 1 on the CPU socket.

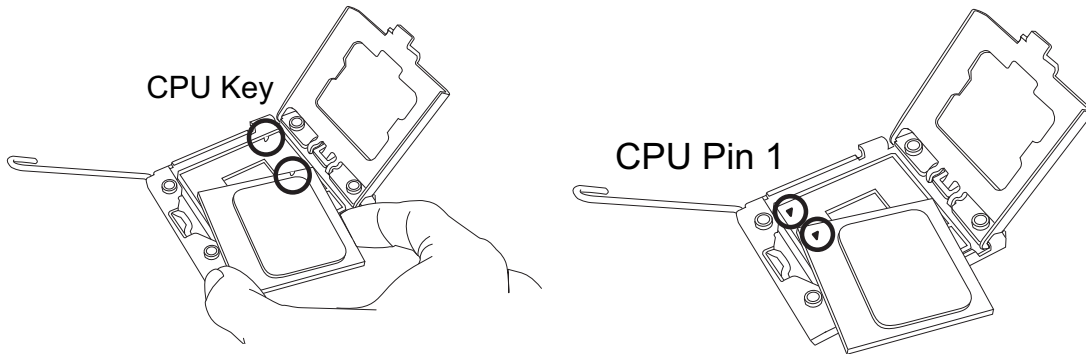

7. Once both the CPU and the socket are aligned, carefully lower the CPU straight down into the socket. To avoid damaging the CPU or the socket, do not rub the CPU against the surface of the socket or the pins.
8. With the CPU inside the socket, inspect the four corners of the CPU to make sure that the CPU is properly and fully installed.
9. Lower the CPU load plate to the socket.
10. Use your thumb to gently push the socket clip down to the clip lock.

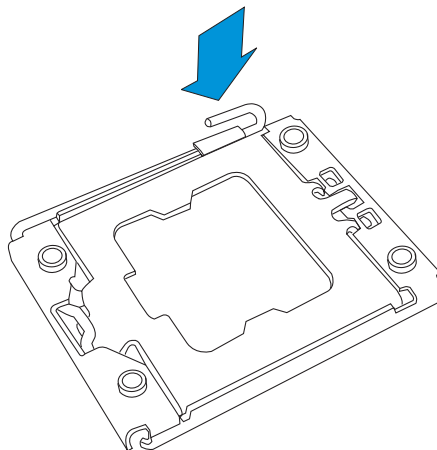

Warning: Save the plastic cap. The serverboard must be shipped with the plastic cap properly installed to protect the CPU socket pins. Shipment without the plastic cap properly installed may cause damage to the socket pins.

Installation and Removal of the Heat Sink

Installing the Heat Sink Installation

1. Do not apply any thermal grease to the heat sink or the CPU die; the required amount has already been applied.
2. Place the heatsink on top of the CPU so that the four mounting holes are aligned with those on the retention mechanism.
3. Screw in two diagonal screws until just snug (do not over-tighten the screws, which may damage the CPU.)
4. Finish the installation by fully tightening all four screws.

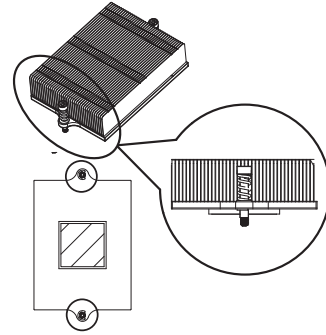

Removing the Heat Sink

Warning: We do not recommend removing the CPU or the heat sink. However, if you do need to uninstall the heat sink, please follow these instructions to avoid damaging the CPU or the CPU socket.

1. Unscrew and remove two diagonal heat sink screws and then the remaining two diagonal screws.
2. Hold the heat sink and gently wriggle to loosen it from the CPU. (Do not use excessive force when doing this!)
3. Once the heat sink is loosened, remove it from the CPU socket.
4. Clean the surface of the CPU and the heat sink to get rid of the old thermal grease. Reapply the proper amount of thermal grease before you re-install the heat sink.

5-6 Installing Memory

Caution: Exercise extreme care when installing or removing DIMM modules to prevent any possible damage.

Memory Support

The X8QB6-F/X8QBE-F supports up to 1024 GB of registered ECC DDR3-1066/800 memory in 32 DIMM slots. Please use memory modules of the same type, speed, timing and same on a serverboard.

Note: See the table belows for memory installation.

Installing Memory Modules

1. Insert the desired number of DIMMs into the memory slots, starting with P1-DIMM #1A.
2. Insert each DIMM module vertically into its slot. Pay attention to the notch along the bottom of the module to avoid installing incorrectly (see Figure 5-3).
3. Gently press down on the DIMM module until it snaps into place in the slot. Make sure that the side notches of the DIMM modules align with the lock/release tabs of the slot when pressed in. Repeat for all modules.
4. Reverse the steps above to remove the DIMM modules from the serverboard.

Figure 5-3. Installing DIMMs

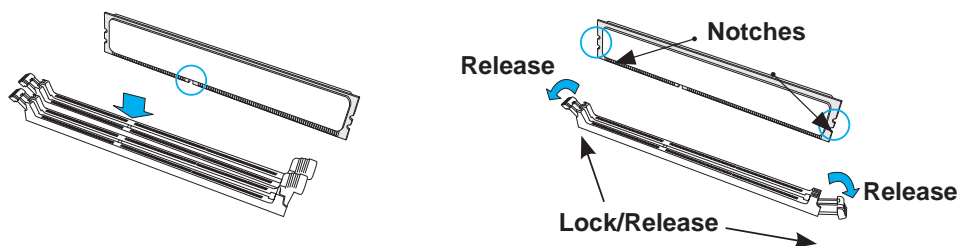

Processors and their Corresponding Memory Modules								
CPU#	Corresponding DIMM Modules							
CPU 1	P1-1A	P1-2A	P1-3A	P1-4A	P1-5A	P1-6A	P1-7A	P1-8A
CPU2	P2-1A	P2-2A	P2-3A	P2-4A	P2-5A	P2-6A	P2-7A	P2-8A
CPU3	P3-1A	P3-2A	P3-3A	P3-4A	P3-5A	P3-6A	P3-7A	P3-8A
CPU4	P4-1A	P4-2A	P4-3A	P4-4A	P4-5A	P4-6A	P4-7A	P4-8A

Processor and Memory Module Population	
Number of CPUs+DIMMs	CPU and Memory Population Configuration Table (For memory to work proper, please install DIMMs in pairs)
1 CPU & 2 DIMMs	CPU1 P1-1A/P1-3A
1 CPU & 4 DIMMs	CPU1 P1-1A/P1-3A, P1-5A/P1-7A
1 CPU & 5-8 DIMMs	CPU1 P1-1A/P1-3A, P1-5A/P1-7A + Any memory pairs in P1-2A/-4A/-6A/-8A DIMM slots
2 CPUs & 4 DIMMs	CPU1 + CPU2 P1-1A/P1-3A, P2-1A/P2-3A
2 CPUs & 6 DIMMs	CPU1 + CPU2 P1-1A/P1-3A/P1-5A/P1-7A, P2-1A/P2-3A
2 CPUs & 8 DIMMs	CPU1 + CPU2 P1-1A/P1-3A/P1-5A/P1-7A, P2-1A/P2-3A/P2-5A/P2-7A
2 CPUs & 10-16 DIMMs	CPU1/CPU2 P1-1A/P1-3A/P1-5A/P1-7A, P2-1A/P2-3A/P2-5A/P2-7A + Any memory pairs in P1, P2 DIMM slots
3 CPUs & 6 DIMMs	CPU1/CPU2 + CPU3 or CPU4 P1-1A/P1-3A, P2-1A/P2-3A + P3-1A/P3-3A (if CPU 3 is installed) P1-1A/P1-3A, P2-1A/P2-3A + P4-1A/P4-3A (if CPU 4 is installed)
3 CPUs & 8 DIMMs	CPU1/CPU2 + CPU3 or CPU4 P1-1A/P1-3A/P1-5A/P1-7A, P2-1A/P2-3A + P3-1A/P3-3A (if CPU 3 is installed) P1-1A/P1-3A/P1-5A/P1-7A, P2-1A/P2-3A + P4-1A/P4-3A (if CPU 4 is installed)
3 CPUs & 10 DIMMs	CPU1/CPU2 + CPU3 or CPU4 P1-1A/P1-3A/P1-5A/P1-7A, P2-1A/P2-3A/P2-5A/P2-7A + P3-1A/P3-3A (if CPU 3 is installed) P1-1A/P1-3A/P1-5A/P1-7A, P2-1A/P2-3A/P2-5A/P2-7A + P4-1A/P4-3A (if CPU 4 is installed)
4 CPUs & 12 DIMMs	CPU1/CPU2 + CPU3 or CPU4 P1-1A/P1-3A/P1-5A/P1-7A, P2-1A/P2-3A/P2-5A/P2-7A + P3-1A/P3-3A/ P3-5A/P3-7A (if CPU 3 is installed) P1-1A/P1-3A/P1-5A/P1-7A, P2-1A/P2-3A/P2-5A/P2-7A + P4-1A/P4-3A/ P4-5A/P4-7A (if CPU 4 is installed)
4 CPUs & 8 DIMMs	CPU1/CPU2/CPU3/CPU4 P1-1A/P1-3A, P2-1A/P2-3A, P3-1A/P3-3A + P4-1A/P4-3A
4 CPUs & 10 DIMMs	CPU1/CPU2/CPU3/CPU4 P1-1A/P1-3A/P1-5A/P1-7A, P2-1A/P2-3A, P3-1A/P3-3A + P4-1A/P4-3A
4 CPUs & 12 DIMMs	CPU1/CPU2/CPU3/CPU4 P1-1A/P1-3A/P1-5A/P1-7A, P2-1A/P2-3A/P2-5A/P2-7A, P3-1A/P3-3A, P4-1A/P4-3A
4 CPUs & 14 DIMMs	CPU1/CPU2/CPU3/CPU4 P1-1A/P1-3A/P1-5A/P1-7A, P2-1A/P2-3A/P2-5A/P2-7A, P3-1A/P3-3A/P3-5A/P3-7A, P4-1A/P4-3A
4 CPUs & 16 DIMMs	CPU1/CPU2/CPU3/CPU4 P1-1A/P1-3A/P1-5A/P1-7A, P2-1A/P2-3A/P2-5A/P2-7A, P3-1A/P3-3A/P3-5A/P3-7A, P4-1A/P4-3A/P4-5A/P4-7A
4 CPUs & 18-32 DIMMs	CPU1/CPU2/CPU3/CPU4 P1-1A/P1-3A/P1-5A/P1-7A, P2-1A/P2-3A/P2-5A/P2-7A, P3-1A/P3-3A/P3-5A/P3-7A, P4-1A/P4-3A/P4-5A/P4-7A + any pairs in the other DIMM slots

RDIMM Support POR on the 7500 Series Processor Platform				
DIMM Slots per DDR Channel	DIMMs Populated per DDR Channel	RDIMM Type (RDIMM: Reg.= Registered)	POR Speeds (in MHz)	Ranks per DIMM (Any Combination)
1	1	Reg. ECC DDR3	800,978, 1066	SR, DR, or QR
2	1	Reg. ECC DDR3	800,978, 1066	SR, DR, or QR
2	2	Reg. ECC DDR3	800,978, 1066	Mixing SR, DR, QR

Population Rules:

- Any combination of x4 and x8 RDIMMs with 1 Gb or 2 Gb DRAM density are supported.
- Populate DIMMs starting with DIMM1A.
- When mixing QR with SR or DR on the same DDR channel, put the QR in DIMM1A first.

Notes and Restrictions

- Only DDR3-1066 RDIMMs are validated at speeds of 800, 978, 1066 MHz.
- For the memory modules to work properly, please install DIMM modules in pairs (with an even number of DIMMs installed).
- All channels in a system will run at the fastest common frequency.

5-7 Adding PCI Add-On Cards

The 8016B-6F/8016B-TF can accommodate one PCI-Express 2.0 x16 card with the use of the RSC-RR1U-E16 riser card inserted into the PCI-E x16 slot.

Installing an Add-on Card

1. Begin by removing the PCI slot shield for the slot you wish to populate.
2. Fully seat the card into the riser card slot, pushing down with your thumbs evenly on both sides of the card.
3. Finish by using a screw to secure the top of the card shield to the chassis. The PCI slot shields protect the serverboard and its components from EMI and aid in proper ventilation, so make sure there is always a shield covering each unused slot.

5-8 Serverboard Details

Figure 5-4. X8QB6-F/X8QBE-F Layout
(not drawn to scale)

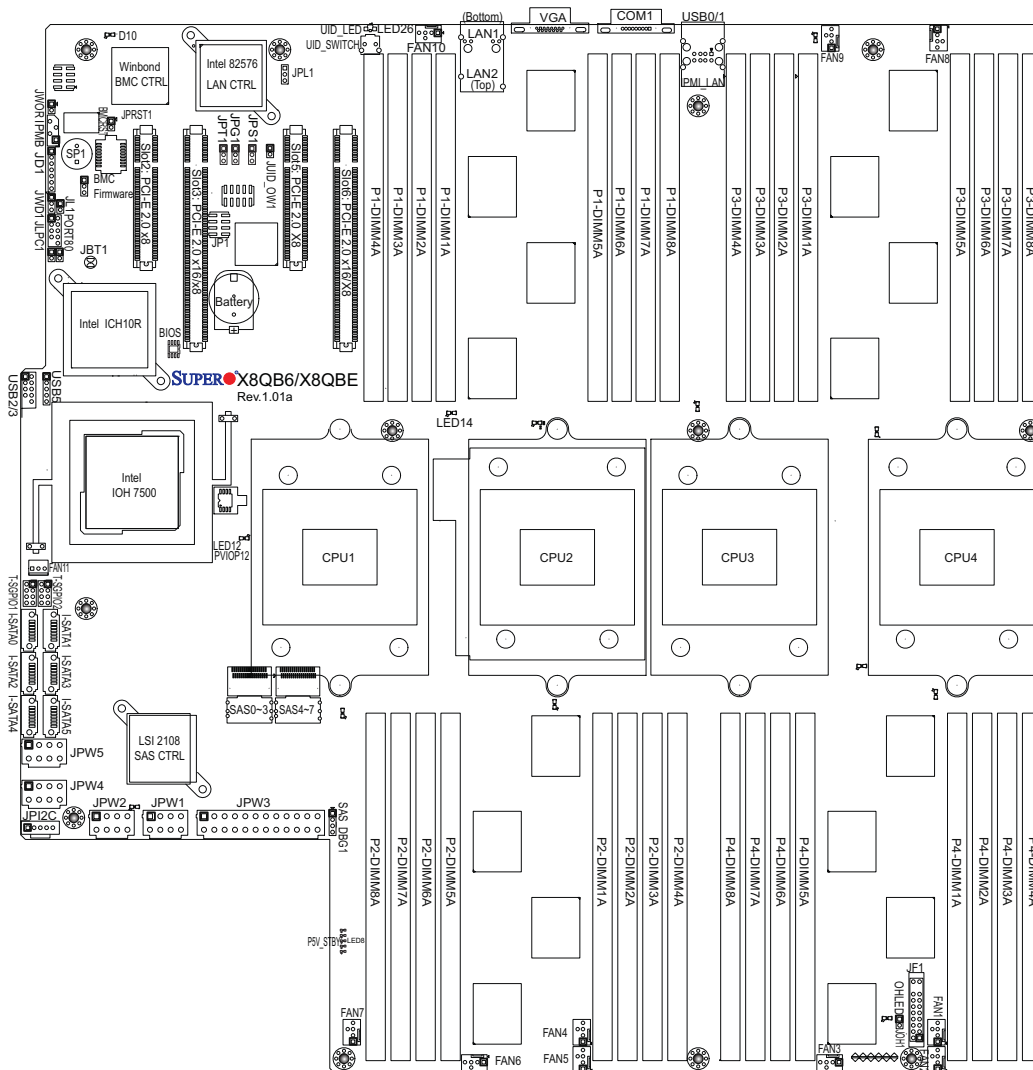

Warning: To prevent damage to the power supply or serverboard, please use a power supply that contains a 24-pin and two 8-pin power connectors. Be sure to connect these connectors to the 24-pin (JPW3) and the four 8-pin (JPW1~2,JPW4~5) power connectors on the serverboard. Failure to do so will void the manufacturer warranty on your power supply and serverboard.

X8QB6-F/X8QBE-F Quick Reference

Jumper	Description	Default Setting
JBT1	Clear CMOS	See Section 5-10
JPG1	VGA Enable/Disable	Pins 1-2 (Enabled)
JPL1	GLAN1/2 Enable/Disable	Pins 1-2 (Enabled)
JPS1 (X8QB6-F only)	SAS2 Enable/Disable	Pins 1-2 (Enabled)
JPT1	TPM Enable/Disable	Pins 1-2 (Enabled)
JWD1	Watch Dog	Pins 1-2 (Reset)

Connector	Description
COM1	COM1 Serial Connection
FAN 1~10	CPU/System Fan Headers (Fan 11: Reserved)
IPMB	4-pin External BMC I ² C Header (for IPMI Card)
I-SATA 0~5	Intel SB SATA Connectors 0~5
JD1	Speaker/Power LED Header
JF1	Control Panel Header
JL1	Chassis Intrusion Header
JLPC1	Port 80
JOH1	Overheat/Fan Fail LED
JPI ² C	Power Supply SMBus I ² C Header
JPW1~2, JP4~5	12V 8-Pin Power Connectors
JPW3	ATX 24-Pin Power Connector
JUID_OW1	UID Override Header
JWOR	Wake-On-Ring
LAN1/LAN2	G-bit Ethernet Ports 1/2
(IPMI) LAN	Dedicated IPMI LAN Port
SAS0~3, SAS4~7	SAS Ports (X8QB6-F only)
TPM/Port 80	Trusted Platform Module/Port 80 Header
T-SGPIO 1/2	Serial General Purpose I/O Headers
USB 0/1	Back Panel USB 0/1 Ports
USB 2/3, 5	Front Panel Accessible USB Headers
UID Switch	UID (Universal Identifier) Switch
LED	Description
D10	BMC Heartbeat LED
LED 8	Standby PWR LED
LED 26	UID LED

5-9 Connector Definitions

Main ATX Power Supply Connector

The primary power supply connector (JPW3) meets the SSI EPS 24-pin specification. Refer to the table on the right for the pin definitions of the ATX 24-pin power connector. You must also connect the four 8-pin processor power connectors to your power supply (see below).

ATX Power 24-pin Connector Pin Definitions			
Pin#	Definition	Pin #	Definition
13	+3.3V	1	+3.3V
14	-12V	2	+3.3V
15	COM	3	COM
16	PS_ON	4	+5V
17	COM	5	COM
18	COM	6	+5V
19	COM	7	COM
20	Res (NC)	8	PWR_OK
21	+5V	9	5VSB
22	+5V	10	+12V
23	+5V	11	+12V
24	COM	12	+3.3V

Processor Power Connector

JPW1, JPW2, JPW4 and JPW5 must also be connected to the power supply to provide power for the processors. See the table on the right for pin definitions.

+12V 8-pin Power Pin Definitions	
Pins	Definition
1 - 4	Ground
5 - 8	+12V

Required Connection

Power Button

The power button connection is located on pins 1 and 2 of JF1. Momentarily contacting both pins will power on/off the system. This button can also be configured to function as a suspend button (with a setting in the BIOS). To turn off the power when the system is set to suspend mode, press the button for at least 4 seconds. Refer to the table on the right for pin definitions.

Power Button Pin Definitions (JF1)	
Pin#	Definition
1	PW_ON
2	Ground

Reset Button

Pins 3 and 4 of JF1 attaches to the reset button on the computer chassis. See the table on the right for pin definitions.

Reset Button Pin Definitions (JF1)	
Pin#	Definition
3	Reset
4	Ground

Overheat/Fan/Pwr Fail/UID LED

Connect an LED to pins 7 and 8 of JF1 to use the Overheat/Fan Fail/Power Fail/UID LED functions. The red LED on pin 7 provides warning of overheating, fan failure or power failure. The blue LED on pin 8 works as the front panel UID LED indicator. The red LED takes precedence over the blue LED by default. Refer to the table on the right for pin definitions.

OH/Fan Fail/ Pwr Fail/UID LED Pin Definitions (JF1)	
Pin#	Definition
7	Red_LED Cathode/OH/Fan Fail/ Power Fail5.5V.SB
8	Blue UID LED

OH/Fan Fail Indicator Status	
State	Definition
Off	Normal
On	Overheat
Flash- ing	Fan Fail

NIC2 (JLAN2) LED

The LED connections for JLAN2 are on pins 9 and 10 of JF1. Attach an LED cable to display network activity. See the table on the right for pin definitions.

NIC2 LED Pin Definitions (JF1)	
Pin#	Definition
9	Vcc
10	Ground

NIC1 (JLAN1) LED

The LED connections for JLAN1 are on pins 11 and 12 of JF1. Attach an LED cable to display network activity. See the table on the right for pin definitions.

NIC1 LED Pin Definitions (JF1)	
Pin#	Definition
11	Vcc
12	Ground

HDD LED

The HDD LED connection is located on pins 13 and 14 of JF1. This LED is used to display all IDE and SATA activity. See the table on the right for pin definitions.

HDD LED Pin Definitions (JF1)	
Pin#	Definition
13	Vcc
14	HD Active

Power On LED

The Power On LED connector is located on pins 15 and 16 of JF1 (use JLED for a 3-pin connector). This connection is used to provide LED indication of power being supplied to the system. See the table on the right for pin definitions.

Power LED Pin Definitions (JF1)	
Pin#	Definition
15	3.3V
16	Control

NMI Button

The non-maskable interrupt button header is located on pins 19 and 20 of JF1. Refer to the table on the right for pin definitions.

NMI Button Pin Definitions (JF1)	
Pin#	Definition
19	Control
20	Ground

Fan Headers

There are ten fan headers on the serverboard, all of which are 4-pin fans. However, pins 1-3 of the fan headers are backward compatible with traditional 3-pin fans. See the table on the right for pin definitions. The onboard fan speeds are controlled by Thermal Management (via Hardware Monitoring) under the Advanced Section in the BIOS. When using Thermal Management setting, please use all 3-pin fans or all 4-pin fans.

Fan Header Pin Definitions	
Pin#	Definition
1	Ground
2	+12V
3	Tachometer
4	PWM Control

Chassis Intrusion

The Chassis Intrusion header is designated JL1. Attach an appropriate cable from the chassis to inform you of a chassis intrusion when the chassis is opened

Chassis Intrusion Pin Definitions (JL1)	
Pin#	Definition
1	Intrusion Input
2	Ground

Wake-On-Ring

The Wake-On-Ring header is designated JWOR. This function allows your computer to receive and be "awakened" by an incoming call when in the suspend state. See the table on the right for pin definitions. You must also have a WOR card and cable to use this feature.

Wake-On-Ring Pin Definitions	
Pin#	Definition
1	Ground (Black)
2	Wake-up

Power LED/Speaker

On JD1 header, pins 1-3 are for a power LED and pins 4-7 are for the speaker. Pins 4-7 are available for connection to an external speaker. If you wish to use the onboard speaker, please close pins 6-7. See the table on the right for speaker pin definitions.

PWR LED Connector Pin Definitions	
Pin Setting	Definition
Pin 1	Anode (+)
Pin2	Cathode (-)
Pin3	NA

Speaker Connector Pin Settings	
Pin Setting	Definition
Pins 4-7	External Speaker
Pins 6-7	Onboard Speaker

Serial Ports

One serial port is included on the I/O backpanel. See the table on the right for pin definitions.

Serial Port Pin Definitions			
Pin #	Definition	Pin #	Definition
1	DCD	6	DSR
2	RXD	7	RTS
3	TXD	8	CTS
4	DTR	9	RI
5	Ground	10	NC

TPM/Port 80

A Trusted Platform Module/Port 80 header provides TPM support and Port 80 connection performance and security enhancement. See the table on the right for pin definitions.

TPM/Port 80 Header Pin Definitions			
Pin #	Definition	Pin #	Definition
1	LCLK	2	GND
3	LFRAME#	4	<(KEY)>
5	LRESET#	6	+5V (X)
7	LAD 3	8	LAD 2
9	+3.3V	10	LAD1
11	LAD0	12	GND
13	SMB_CLK4	14	SMB_DAT4
15	+3V_DUAL	16	SERIRQ
17	GND	18	CLKRUN# (X)
19	LPCPD#	20	LDRQ# (X)

Overheat LED/Fan Fail

The JOH1 header is used to connect an LED to provide warning of chassis overheating. This LED will blink to indicate a fan failure. Refer to the table on right for pin definitions.

OH/Fan Fail LED States		Overheat LED Pin Definitions	
State	Message	Pin#	Definition
Solid	Overheat	1	5vDC
Blinking	Fan Fail	2	OH Active

Power SMB (I2C)

The Power System Management Bus (I²C) header (JPI²C) monitors power supply, fan and system temperatures. See the table on the right for pin definitions.

Power SMB Pin Definitions	
Pin#	Definition
1	Clock
2	Data
3	PWR Fail
4	Ground
5	+3.3V

IPMB

A System Management Bus header for IPMI 2.0 is located at IPMB. Connect the appropriate cable here to use the IPMB I²C connection on your system.

IPMB Header Pin Definitions	
Pin#	Definition
1	Data
2	Ground
3	Clock
4	No Connection

T-SGPIO 1/2 Headers

Two SGPIO (Serial-Link General Purpose Input/Output) headers are located on the motherboard. These headers support Serial_Link interfaces for onboard SATA connections. See the table on the right for pin definitions.

T-SGPIO Pin Definitions			
Pin#	Definition	Pin	Definition
1	NC	2	NC
3	Ground	4	Data
5	Load	6	Ground
7	Clock	8	NC

NC = No Connection

LAN1/2 (Ethernet Ports)

Two Ethernet ports (designated LAN1 and LAN2) are located on the I/O back-plane. A dedicated IPMI LAN port (above the USB0/1 ports) is also provided. These ports accept RJ45 type cables.



Universal Serial Bus (USB)

There are two Universal Serial Bus ports located on the I/O panel and three additional USB headers located on the serverboard. The headers can be used to provide front side USB access (cables not included). See the table on the right for pin definitions.

Universal Serial Bus Pin Definitions (USB)			
USB0/1		USB2/3, 5	
Pin #	Definition	Pin #	Definition
1	+5V	1	+5V
2	PO-	2	PO-
3	PO+	3	PO+
4	Ground	4	Ground
5	N/A	5	NC or Key

NC = No Connection

Unit Identifier Switch

A Unit Identifier (UID) switch and two LED indicators are provided on the serverboard. The UID Switch is located next to the LAN ports on the I/O back-plane. The rear UID LED (LED26) is located next to the UID switch. The Front Panel UID LED is located on pin 8 of JF1 (Control Panel header). Connect a cable to pin 8 on JF1 for the Front Panel UID LED. When you press the UID switch, both the rear and the Front Panel UID indicators will be turned on. Press the UID switch again to turn off both LED Indicators. These UID Indicators provide easy identification of a system unit that may be in need of service.

UID Switch	
Pin#	Definition
1	Ground
2	Ground
3	Button In
4	Ground

UID LED (LE2) Status		
Color/State	OS	Status
Blue: On	Windows OS	Unit Identified
Blue: Blinking	Linux OS	Unit Identified

Note: UID can also be triggered via IPMI. For more information on IPMI, please refer to the IPMI User's Guide posted on our Website @ <http://www.supermicro.com>.

5-10 Jumper Settings

Explanation of Jumpers

To modify the operation of the serverboard, jumpers can be used to choose between optional settings. Jumpers create shorts between two pins to change the function of the connector. Pin 1 is identified with a square solder pad on the printed circuit board. See the serverboard layout pages for jumper locations.

Note: On a two-pin jumper, "Closed" means the jumper is on both pins and "Open" means the jumper is either on only one pin or completely removed.

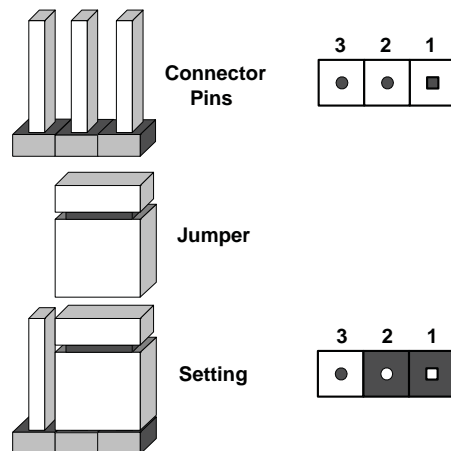

CMOS Clear

JBT1 is used to clear CMOS (which will also clear any passwords). Instead of pins, this jumper consists of contact pads to prevent accidentally clearing the contents of CMOS.

To clear CMOS,

1. First power down the system and unplug the power cord(s).
2. With the power disconnected, short the CMOS pads with a metal object such as a small screwdriver.
3. Remove the screwdriver (or shorting device).
4. Reconnect the power cord(s) and power on the system.

Note: Do not use the PW ON connector to clear CMOS.

VGA Enable/Disable

JPG1 allows you to enable or disable the VGA port. The default position is on pins 1 and 2 to enable VGA. See the table on the right for jumper settings.

VGA Enable/Disable Jumper Settings (JPG1)	
Jumper Setting	Definition
Pins 1-2	Enabled
Pins 2-3	Disabled

GLAN1/2 Enable/Disable

Change the setting of jumper JPL1 to enable or disable the GLAN1/GLAN2 Ethernet port on the serverboard. The default setting is enabled. See the table on the right for jumper settings.

GLAN1/2 Enable/Disable Jumper Settings (JPL1)	
Jumper Setting	Definition
Pins 1-2	Enabled
Pins 2-3	Disabled

TPM Support Enable/Disable

Jumper JPT1 is used to enable TPM (Trusted Platform Module) support to enhance data integrity and system security. See the table on the right for jumper settings. The default setting is enabled.

TPM Support Enable/Disable Jumper Settings	
Jumper Setting	Definition
1-2	Enabled
2-3	Disabled

Watch Dog Enable/Disable

JWD controls the Watch Dog function. Watch Dog is a system monitor that can reboot the system when a software application hangs. Jumping pins 1-2 (the default setting) will cause WD to reset the system if an application hangs. Jumping pins 2-3 will generate a non-maskable interrupt signal for the application that hangs. See the table on the right for jumper settings. Watch Dog must also be enabled in BIOS.

Watch Dog Jumper Settings (JWD)	
Jumper Setting	Definition
Pins 1-2	Reset
Pins 2-3	NMI
Open	Disabled

Note: When enabled, the user needs to write their own application software in order to disable the Watch Dog Timer.

SAS2 Enable (X8QB6-F only)

Close pins 1-2 to enable SAS (Serial Attached SCSI) support on the 8016B-6F (X8QB6-F serverboard). See the table on the right for jumper settings. The default setting is enabled.

SAS2 Enable Jumper Settings	
Jumper Setting	Definition
1-2	Enabled (Default)
2-3	Disabled

5-11 Onboard Indicators**GLAN1/2 LEDs**

The Ethernet ports located on the I/O backpanel have two LEDs. On each port, one LED indicates activity while the other LED may be green, amber or off to indicate the speed of the connection. See the table on the right for the functions associated with the connection speed LED.

GLAN1/2 LED (Connection Speed Indicator)	
LED Color	Definition
Off	NC or 10 Mb/s
Green	100 Mb/s
Amber	1 Gb/s

Dedicated IPMI LAN LEDs

In addition to the two LAN ports described above, a dedicated IPMI LAN is also located on the I/O panel. The amber LED on the right indicates activity, while the green LED on the left indicates the speed of the connection. See the table at right for more information.

IPMI LAN LEDs		
LED	Color/State	Definition
Left	Green: Solid	100 Mb/s
Right	Amber: Blinking	Activity

Rear UID LED

The rear UID LED is located on the backplane. This LED is used in conjunction with the rear UID switch to provide easy identification of a system that might be in need of service. Refer to UID Switch for more information.

UID LED		
Color/State	OS	Status
Blue: On	Windows OS	Unit Identified
Blue: Blinking	Linux OS	Unit Identified

Standby Power LED

A standby power LED is located at LED 8 on the serverboard. When this LED is lit, the system is on. Be sure to turn off the system and unplug the power cord before removing or installing components. See the table at right for more information.

Stannby PWR LED	
LED Color	Definition
Off	System Off (PWR cable not connected)
Green	System On
Green: Flashing Quickly	ACPI S1 State
Green: Flashing Slowly	ACPI S3 (STR) State

BMC Heartbeat LED

A BMC Heartbeat LED is located at D10 on the serverboard. When D10 is blinking it indicates that the BMC is functioning normally. See the table at right for more information.

BMC Heartbeat LED	
Color/State	Definition
Green: Blinking	BMC: Normal

5-12 SAS and SATA Ports

SATA Ports

There are no jumpers to configure the onboard SATA connectors. These ports are supported by the Intel ICH10R South Bridge portion of the chipset. See the table on the right for pin definitions.

SATA Port Pin Definitions (I-SATA0 ~ I-SATA5)	
Pin #	Definition
1	Ground
2	TXP
3	TXN
4	Ground
5	RXN
6	RXP
7	Ground

SAS Ports (8016B-6F only)

Eight Serial Attached SCSI Ports (SAS 0~3, 4~7) are located on the 8016B-6F (X8QB6-F) to provide serial link connections. These ports are supported by the LSI 2108 controller. See the table on the right for pin definitions.

SAS Port Pin Definitions (SAS0~3, SAS4~7)	
Pin #	Definition
1	Ground
2	TXP
3	TXN
4	Ground
5	RXN
6	RXP
7	Ground

5-13 Installing Software

The Supermicro ftp site contains drivers and utilities for your system at <ftp://ftp.supermicro.com>. Some of these must be installed, such as the chipset driver.

After accessing the ftp site, go into the CDR_Images directory and locate the ISO file for your motherboard. Download this file to create a CD/DVD of the drivers and utilities it contains. (You may also use a utility to extract the ISO file if preferred.)

Another option is to go to the Supermicro Website at <http://www.supermicro.com/products/>. Find the product page for your motherboard here, where you may download individual drivers and utilities.

After creating a CD/DVD with the ISO files, insert the disk into the CD/DVD drive on your system and the display shown in Figure 5-5 should appear.

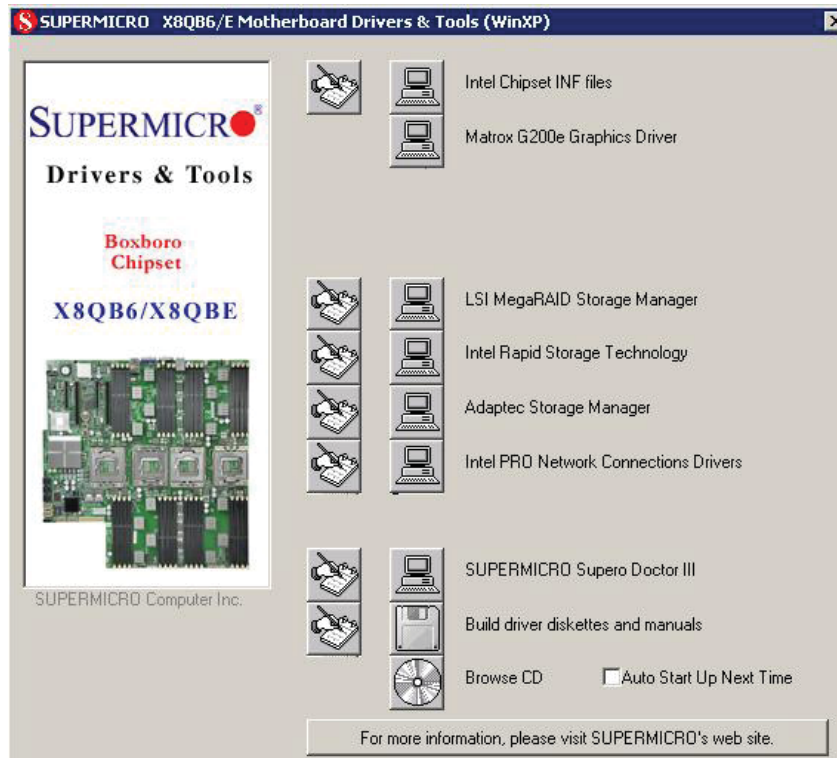

Figure 5-5. SuperDoctor III Interface Display Screen (Health Information)

Note: Click the icons showing a hand writing on paper to view the readme files for each item. Click the computer icons to the right of these items to install each item (from top to the bottom) one at a time. **After installing each item, you must re-boot the system before moving on to the next item on the list.** The bottom icon with a CD on it allows you to view the entire contents of the CD.

SuperDoctor III

The SuperDoctor® III program is a web-based management tool that supports remote management capability. It includes Remote and Local Management tools. The local management is called SD III Client. The SuperDoctor III program allows you to monitor the environment and operations of your system. SuperDoctor III displays crucial system information such as CPU temperature, system voltages and fan status. See the figures below for examples of the SuperDoctor III interface.

Note: The default User Name and Password for SuperDoctor III is ADMIN / ADMIN.

Note: When SuperDoctor III is first installed, it adopts the temperature threshold settings that have been set in BIOS. Any subsequent changes to these thresholds must be made within SuperDoctor III, as the SuperDoctor III settings override the BIOS settings. To set the BIOS temperature threshold settings again, you would first need to uninstall SuperDoctor III.

Figure 5-6. SuperDoctor III Interface Display Screen (Remote Control)

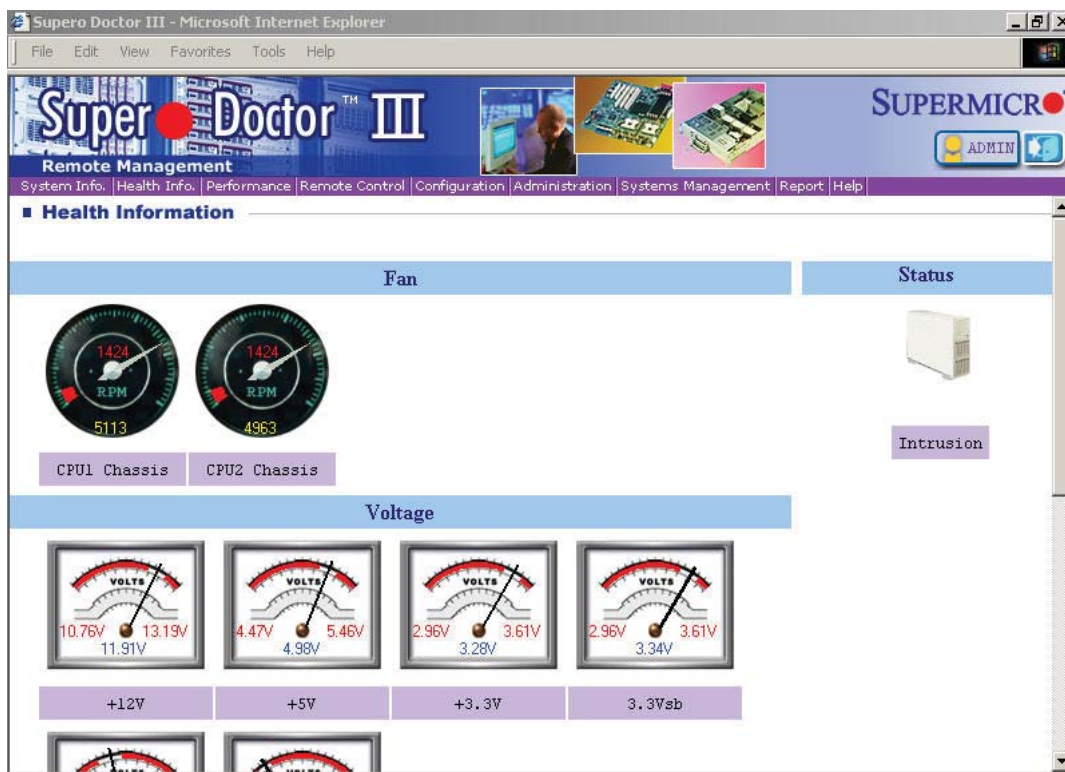

Figure 5-7. SuperDoctor III Interface Display Screen (Remote Control)

Note: The SuperDoctor III program and User's Manual can be downloaded from the Supermicro web site at <http://www.supermicro.com/products/accessories/software/SuperDoctorIII.cfm>. For Linux, we recommend that you use the SuperDoctor II application instead.

Chapter 6

Advanced Chassis Setup

This chapter covers the steps required to install components and perform maintenance on the SC818A-1400B chassis. For component installation, follow the steps in the order given to eliminate the most common problems encountered. If some steps are unnecessary, skip ahead to the next step.

Tools Required: The only tool you will need to install components and perform maintenance is a Philips screwdriver.

6-1 Static-Sensitive Devices

Electrostatic Discharge (ESD) can damage electronic components. To prevent damage to any printed circuit boards (PCBs), it is important to handle them very carefully. The following measures are generally sufficient to protect your equipment from ESD damage.

Precautions

- Use a grounded wrist strap designed to prevent static discharge.
- Touch a grounded metal object before removing any board from its antistatic bag.
- Handle a board by its edges only; do not touch its components, peripheral chips, memory modules or gold contacts.
- When handling chips or modules, avoid touching their pins.
- Put the serverboard, add-on cards and peripherals back into their antistatic bags when not in use.
- For grounding purposes, make sure your computer chassis provides excellent conductivity between the power supply, the case, the mounting fasteners and the serverboard.

Figure 6-1. Chassis: Front and Rear Views

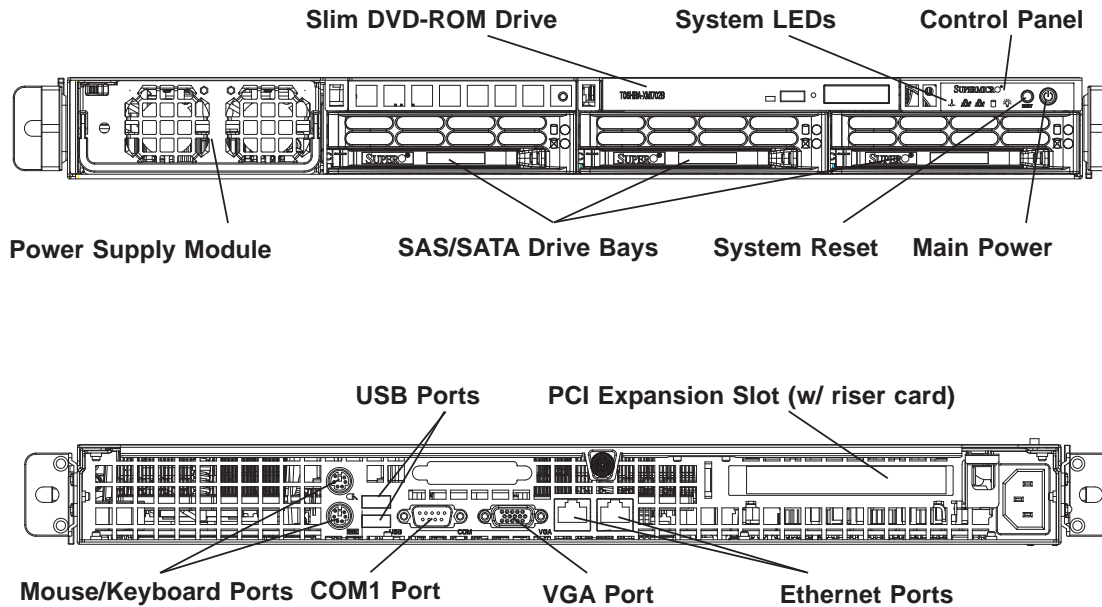

6-2 Control Panel

The control panel (located on the front of the chassis) must be connected to the JF1 connector on the serverboard to provide you with system status indications. These wires have been bundled together as a ribbon cable to simplify the connection. Connect the cable from JF1 on the serverboard to the appropriate header on the Control Panel PCB (printed circuit board). Make sure the red wire plugs into pin 1 on both connectors. Pull all excess cabling out of the airflow path.

The control panel LEDs inform you of system status. See "Chapter 3: System Interface" for details on the LEDs and the control panel buttons. Details on JF1 can be found in "Chapter 5: Advanced Serverboard Setup."

6-3 System Fans

Seven 4-cm heavy duty counter-rotating fans provide the cooling for the 8016B-6F/8016B-TF. Each fan unit is actually made up of two fans joined back-to-back, which rotate in opposite directions. This counter-rotating action generates exceptional airflow and works to dampen vibration levels. It is very important that the chassis top cover is properly installed and making a good seal in order for the cooling air to circulate properly through the chassis and cool the components. See Figure 6-2.

System Fan Failure

Fan speed is controlled by system temperature via a BIOS setting. If a fan fails, the remaining fan will ramp up to full speed and the overheat/fan fail LED on the control panel will turn on. Replace any failed fan at your earliest convenience with the same type and model (the system can continue to run with a failed fan). Remove the top chassis cover while the system is still running to determine which of the fans has failed. Then power down the system before replacing a fan. Removing the power cord(s) is also recommended as a safety precaution.

Replacing System Fans

Removing a Fan

After turning off the power to the system, first remove the chassis cover and unplug the fan cable from the serverboard. Unscrew the failed blower fan from the chassis and pull it completely out from the serverboard.

Installing a New Fan

Replace the failed fan with an identical 4-cm, 12 volt fan (available from Supermicro: p/n FAN-0101L4). Push the new fan into the vacant space in the housing while making sure the arrows on the top of the fan (indicating air direction) point in the same direction as the arrows on the other fans. Reposition the fan housing back over the two mounting posts in the chassis, then reconnect the fan wires to the same chassis fan headers you removed them from. Power up the system and check that the fan is working properly and that the LED on the control panel has turned off. Finish by replacing the chassis cover.

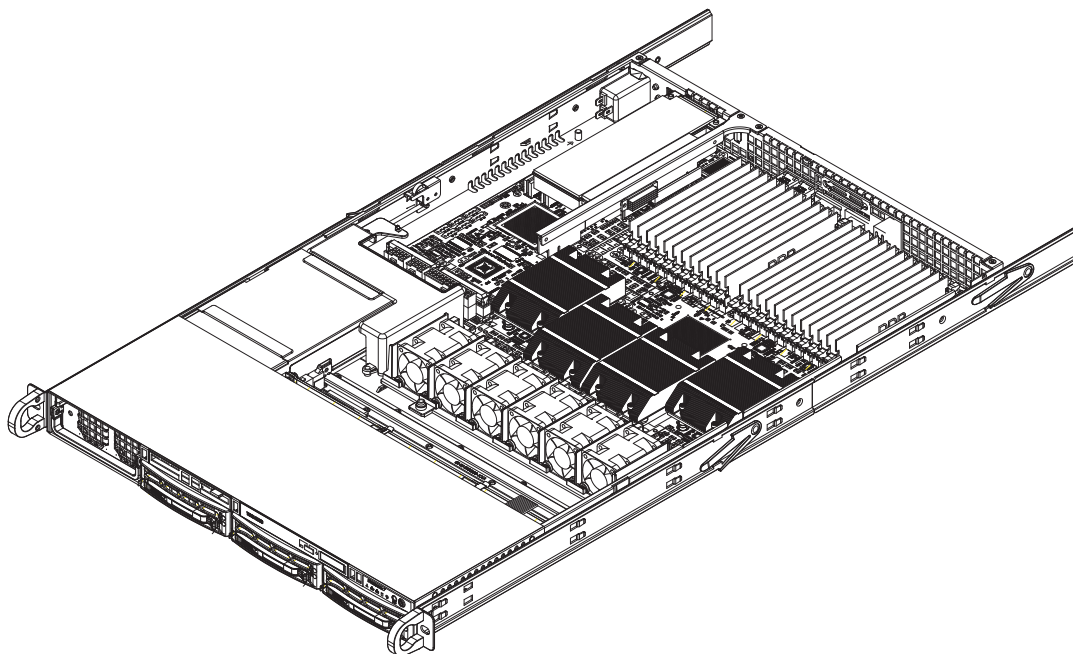
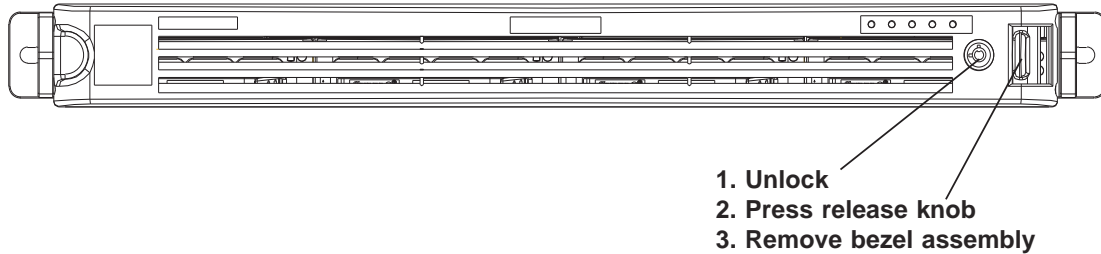

Figure 6-2. System Cooling Fans

6-4 Drive Bay Installation

Removing the Front Bezel

If your system has a front bezel (optional) attached to the chassis, you must first remove it to gain access to the drive bays. To remove the bezel, first unlock the front of the chassis then press the release knob (see Figure 6-3). Carefully remove the bezel with both hands. A filter located within the bezel can be removed for replacement/cleaning. It is recommended that you keep a maintenance log of filter cleaning/replacement, since its condition will affect the airflow throughout the whole system.

Figure 6-3. Removing the Front Bezel

Accessing the Drive Bays

SAS/SATA Drives: Because of their hotswap capability, you do not need to access the inside of the chassis or power down the system to install or replace SAS or SATA drives. Proceed to the next section for instructions.

DVD-ROM/Floppy Disk Drives: For installing/removing a DVD-ROM or floppy disk drive, you will need to gain access to the inside of the 8016B-6F/8016B-TF by removing the top cover of the chassis. Proceed to the "DVD-ROM and Floppy Drive Installation" section later in this chapter for instructions.

Note: Only "slim" DVD-ROM and floppy drives will fit into the 8016B-6F/8016B-TF.

SAS/SATA Drive Installation

Mounting a Drive in a Drive Carrier

The SAS/SATA drives are mounted in drive carriers to simplify their installation and removal from the chassis. These carriers also help promote proper airflow for the drive bays. For this reason, even empty carriers without drives installed must remain in the chassis. To add a new drive, install a drive into the carrier with the printed circuit board side facing down so that the mounting holes align with those in the carrier. Secure the drive to the carrier with six screws, as shown in Figure 6-4.

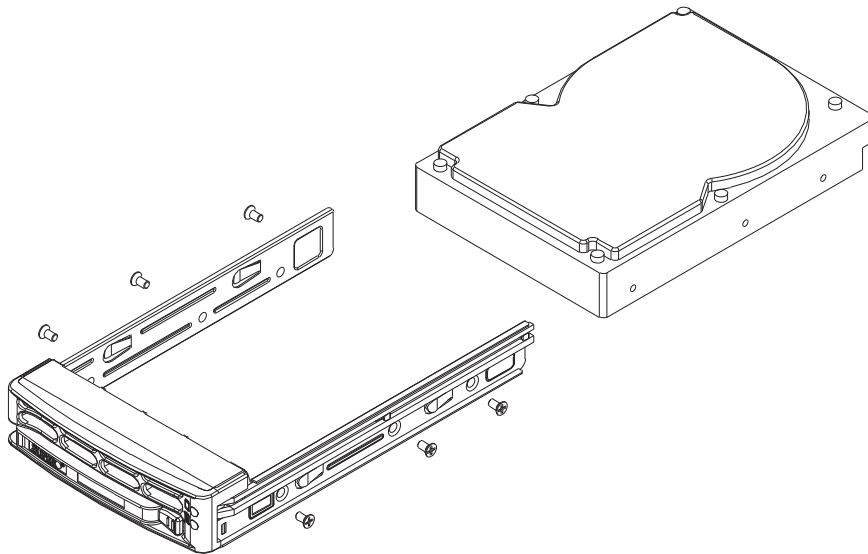

Figure 6-4. Mounting a Drive in a Carrier

Important: Enterprise level hard disk drives are recommended for use in Supermicro chassis and servers. For information on recommended HDDs, visit the Supermicro Web site at <http://www.supermicro.com/products/nfo/files/storage/SAS-1-CompList-110909.pdf>

Warning: Regardless of how many hard drives are installed, all drive carriers must remain in the drive bays to maintain proper airflow.

Installing/Removing SAS/SATA Drives

The drive carriers are all easily accessible at the front of the chassis. These hard drives are hot-pluggable, meaning they can be removed and installed without powering down the system.

To remove a carrier, push the release button located beside the drive LEDs. Then swing the colored handle fully out and use it to pull the unit straight out (see Figure 6-5).

Note: Your operating system must have RAID support to enable the hot-plug capability of the SAS/SATA drives.

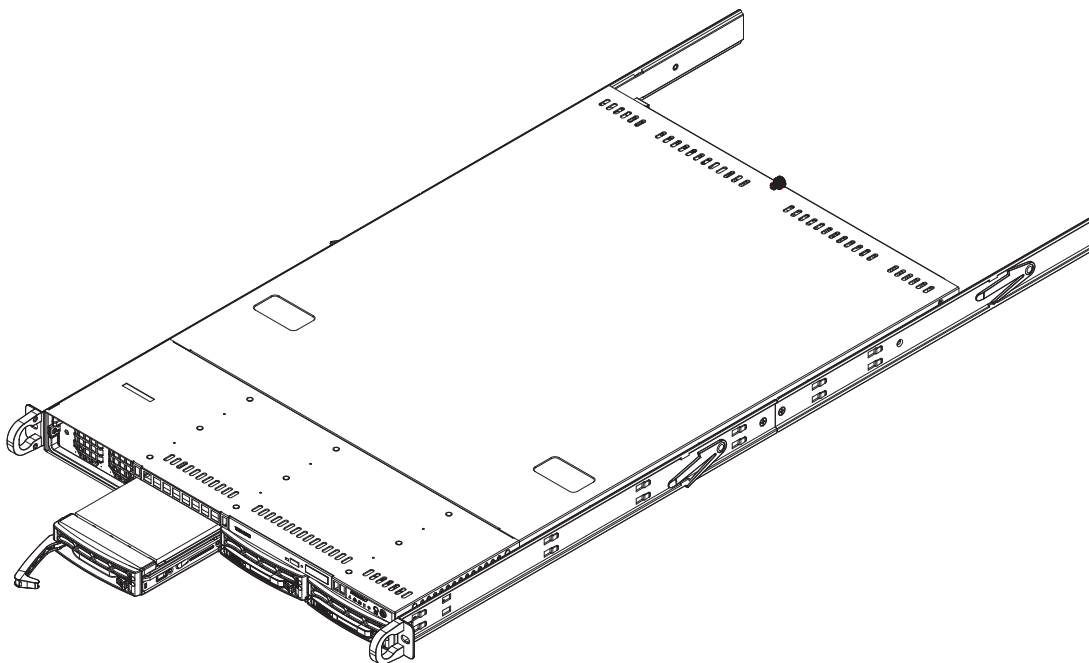

Figure 6-5. Removing a Drive from the Server

SAS/SATA Backplane

The SATA drives plug into a backplane that provides power, drive ID and bus termination. A RAID controller can be used with the backplane to provide data security. The operating system you use must have RAID support to enable the hot-swap capability of the drives. The backplane is already preconfigured, so there are no jumpers or switches present on it.

Warning: Use caution when working around the SAS/SATA backplane. Do not touch the backplane with any metal objects and make sure no ribbon cables touch the backplane or obstruct the holes, which aid in proper airflow.

DVD-ROM and Floppy Drive Installation

The top cover of the chassis must be opened to gain full access to the DVD-ROM and floppy drive bays. The 8016B-6F/8016B-TF accommodates only slim-line DVD-ROM drives. Side mounting brackets are needed to mount a slim-line DVD-ROM drive in the 8016B-6F/8016B-TF server.

You must power down the system before installing or removing a floppy or DVD-ROM drive. First, grasp the two handles on either side and pull the unit straight out until it locks (you will hear a "click"). Next, release the thumbscrew at the rear of the top chassis cover. Then depress the two buttons on the top of the chassis and at the same time, push the cover away from you until it stops. You can then lift the top cover from the chassis to gain full access to the inside of the server.

With the chassis cover removed, unplug the power and data cables from the drive you want to remove. Then locate the locking tab at the rear of the drive. It will be on the left side of the drive when viewed from the front of the chassis. Pull the tab away from the drive and push the drive unit out the front of the chassis. Add a new drive by following this procedure in reverse order. You may hear a faint *click* of the locking tab when the drive is fully inserted. Remember to reconnect the data and power cables to the drive before replacing the chassis cover and restoring power to the system. Please be aware of the following:

- The floppy disk drive cable has seven twisted wires.
- A color mark on a cable typically designates the location of pin 1.
- A single floppy disk drive ribbon cable has 34 wires and two connectors to provide for two floppy disk drives. The connector with twisted wires always connects to drive A, and the connector that does not have twisted wires always connects to drive B.

6-5 Power Supply

The SuperServer 8016B-6F/8016B-TF has a single 1400 watt power supply, which is auto-switching capable. This enables it to automatically sense and operate at a 100v to 240v input voltage. An amber light will be illuminated on the power supply when the power is off. An illuminated green light indicates that the power supply is operating.

Power Supply Failure

If the power supply unit fails, the system will shut down and you will need to replace the unit. Replacement units can be ordered directly from Supermicro (see contact information in the Preface). As there is only one power supply unit in the 8016B-6F/8016B-TF, power must be completely removed from the server before removing and replacing the power supply unit for whatever reason.

Removing the Power Supply

First unplug the power cord from the failed power supply module. The power supply module is cold-swappable. To remove the failed power module, simply push the release tab (on the back of the power supply) to the side and then pull the module straight out (see Figure 6-6). The power supply wiring was designed to detach automatically when the module is pulled from the chassis.

Installing a New Power Supply

Replace the failed power module with another PWS-1K01-1R power supply module. Push the new power supply module into the power bay until you hear a click. Finish by plugging the AC power cord back into the module and powering up the system by depressing the power on/off button.

Figure 6-6. Removing/Replacing the Power Supply

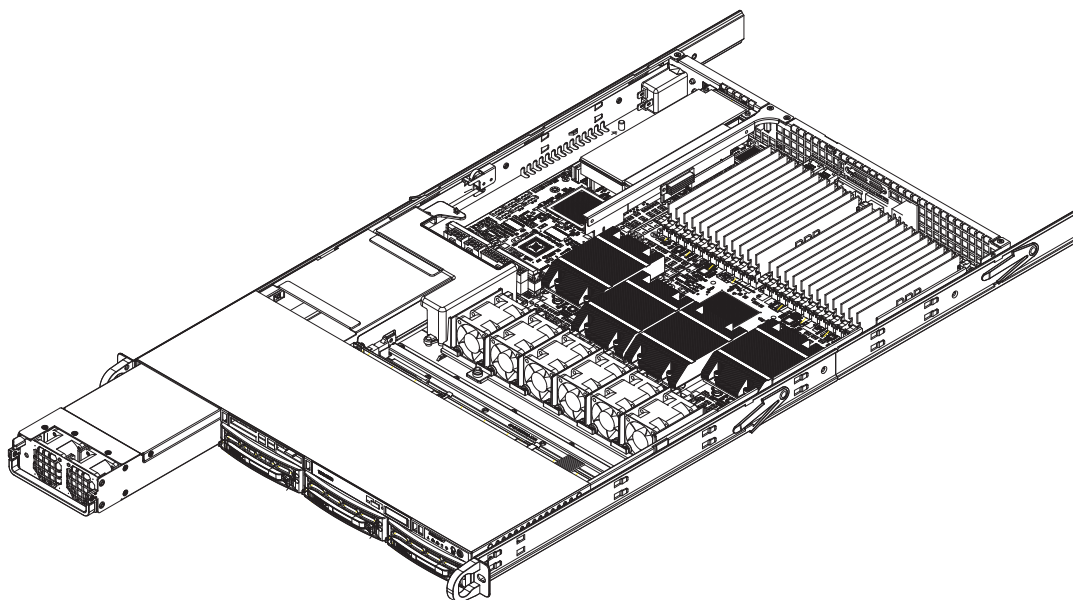

Chapter 7

BIOS

7-1 Introduction

This chapter describes the AMI BIOS Setup Utility for the X8QB6-F/X8QBE-F. The AMI ROM BIOS is stored in a Flash EEPROM and can be easily updated. This chapter describes the basic navigation of the AMI BIOS Setup Utility setup screens.

Starting BIOS Setup Utility

To enter the AMI BIOS Setup Utility screens, press the <Delete> key while the system is booting up.



Note: In most cases, the <Delete> key is used to invoke the AMI BIOS setup screen. There are a few cases when other keys are used, such as <F1>, <F2>, etc.

Each main BIOS menu option is described in this manual. The Main BIOS setup menu screen has two main frames. The left frame displays all the options that can be configured. Grayed-out options cannot be configured. Options in blue can be configured by the user. The right frame displays the key legend. Above the key legend is an area reserved for text messages. When an option is selected in the left frame, it is highlighted in white. Often a text message will accompany it. (**Note:** AMI BIOS has default text messages built in. Supermicro retains the option to include, omit, or change any of these text messages.)

The AMI BIOS Setup Utility uses a key-based navigation system called "hot keys." Most of the AMI BIOS setup utility "hot keys" can be used at any time during the setup navigation process. These keys include <F1>, <F10>, <Enter>, <ESC>, arrow keys, etc.



Note: Options printed in **Bold** are default settings.

How To Change the Configuration Data

The configuration data that determines the system parameters may be changed by entering the AMI BIOS Setup utility. This Setup utility can be accessed by pressing at the appropriate time during system boot.



Note: For AMI BIOS Recovery, please refer to the AMI BIOS Recovery Instructions posted on our website at <http://www.supermicro.com/support/manuals/>.

Starting the Setup Utility

Normally, the only visible Power-On Self-Test (POST) routine is the memory test. As the memory is being tested, press the <Delete> key to enter the main menu of the AMI BIOS Setup Utility. From the main menu, you can access the other setup screens. An AMI BIOS identification string is displayed at the left bottom corner of the screen below the copyright message.

Warning! Do not upgrade the BIOS unless your system has a BIOS-related issue. Flashing the wrong BIOS can cause irreparable damage to the system. In no event shall Supermicro be liable for direct, indirect, special, incidental, or consequential damages arising from a BIOS update. If you have to update the BIOS, do not shut down or reset the system while the BIOS is updating to avoid possible boot failure.

7-2 Main Setup

When you first enter the AMI BIOS Setup Utility, you will enter the Main setup screen. You can always return to the Main setup screen by selecting the Main tab on the top of the screen. The Main BIOS Setup screen is shown below.

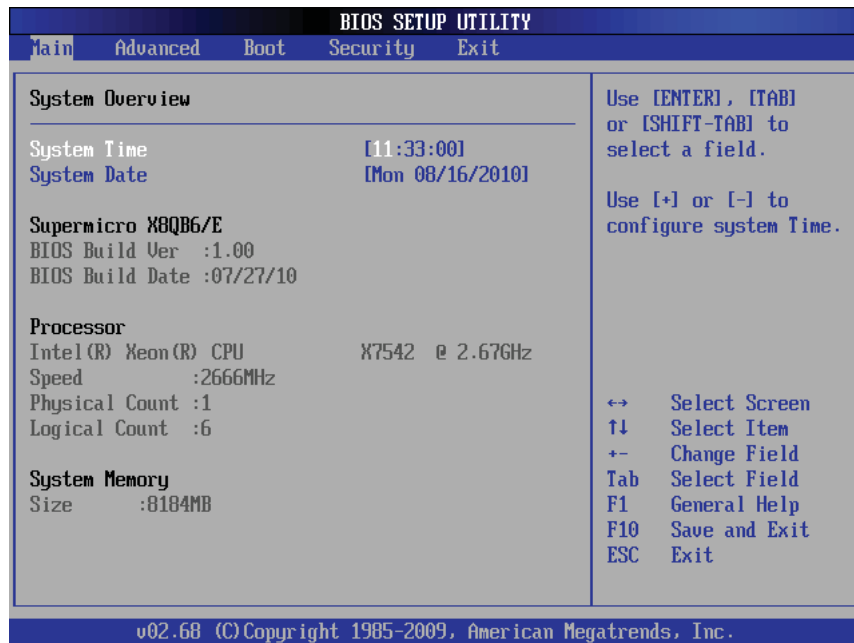

System Overview: The following BIOS information will be displayed:

System Time/System Date

Use this option to change the system time and date. Highlight *System Time* or *System Date* using the arrow keys. Enter new values through the keyboard and press <Enter>. Press the <Tab> key to move between fields. The date must be entered in Day MM/DD/YY format. The time is entered in HH:MM:SS format. (**Note:** The time is in the 24-hour format. For example, 5:30 P.M. appears as 17:30:00.)

Supermicro X8QB6/E

- **BIOS Version:** This item displays the BIOS version used in your system.
- **BIOS Build Date:** This item displays the date when this BIOS was built.

Processor

The AMI BIOS will automatically display the status of the processor used in your system:

- **CPU Type:** This item displays the type of CPU used in the motherboard.
- **Speed:** This item displays the CPU speed as detected by the BIOS.
- **Physical Count:** This item displays the number of processors installed in your system as detected by BIOS.
- **Logical Count:** This item displays the number of CPU Cores detected in your system by BIOS.

System Memory

- **Size:** This displays the size of memory available in the system.

7-3 Advanced Setup Configurations

Use the arrow keys to select Advanced Settings and press <Enter> to access the submenu items.

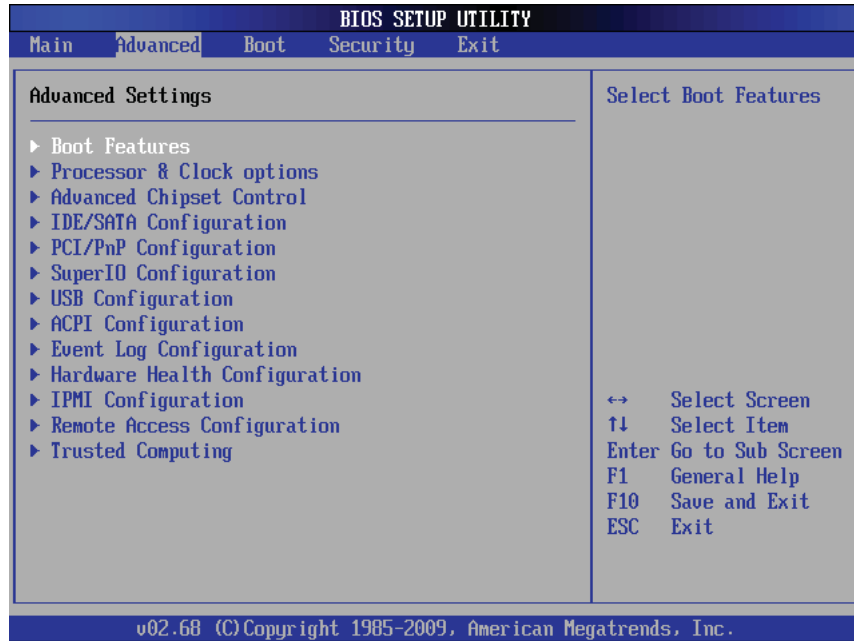

Warning: Be sure to select the correct setting for each item in this section. A wrong setting selected may cause the system to malfunction.

▶ Boot Features

Quick Boot

If enabled, this feature will skip certain tests during POST to reduce the time needed for system boot. The options are **Enabled** and Disabled.

Quiet Boot

Use this feature to select the bootup screen display between POST messages or the OEM logo. Select Disabled to display the POST messages. Select Enabled to display the OEM logo instead of the normal POST messages. The options are **Enabled** and Disabled.

AddOn ROM Display Mode

This feature sets the display mode for the Option ROM. The options are **Force BIOS** and Keep Current.

Bootup Num-Lock

This feature is used to select the Power-on state for the Numlock key. The options are Off and **On**.

PS/2 Mouse Support

Select Enabled to enable PS/2 Mouse support. Select **Auto** to enable the onboard PS/2 mouse when a PS/2 mouse is detected. The options are Enable, Disabled, and **Auto**.

Wait For 'F1' If Error

This forces the system to wait until the 'F1' key is pressed when an error occurs. The options are Disabled and **Enabled**.

Hit 'Del' Message Display

Select Enabled to display "Press DEL to run Setup" during POST. The options are **Enabled** and Disabled.

Interrupt 19 Capture

Interrupt 19 is the software interrupt that handles boot disk functions. When this item is set to Enabled, the ROM BIOS of the host adaptors will "capture" Interrupt 19 at bootup and allow the drives that are attached to these host adaptors to function as bootable disks. If this item is set to Disabled, the ROM BIOS of the host adaptors will not capture Interrupt 19, and the drives attached to these adaptors will not function as bootable devices. The options are **Enabled** and Disabled.

Watch Dog Function

If enabled, the Watch Dog Timer will allow the system to reboot when it is inactive for more than 5 minutes. The options are Enabled and **Disabled**.

► Processor and Clock Options

This submenu displays the status of the processor used in the motherboard and allows the user to configure the Processor and Clock settings.

Spread Spectrum Mode

Select Enable to enable Clock Spectrum modulation support, which will allow BIOS to monitor and attempt to reduce the level of Electromagnetic Interference caused by the components whenever needed. The options are **Disabled** and Enabled.

Ratio CMOS Setting (Available when CPU Ratio is set to manual)

This option allows the user to set the ratio between the CPU Core Clock and the FSB Frequency. (**Note:** if an invalid ratio is entered, the AMI BIOS will restore the setting to the previous state.) The default setting depends on the type of CPU installed on the motherboard. The default setting for this motherboard is [20].

Sever Class

Use this item to identify the server class for your system so that the prefetcher settings listed below can be correctly configured. The options are Enterprise, **HPC (High Performance Cluster)** and Custom (for customized servers).

Hardware Prefetcher (Available when supported by the CPU)

If enabled, the hardware prefetcher will prefetch streams of data and instructions from the main memory to the L2 cache to improve CPU performance. The options are Disabled and **Enabled**.

Adjacent Cache Line Prefetch (Available when supported by the CPU)

If this feature is set to Disabled, the CPU prefetches the cache line for 64 bytes. If this feature is set to **Enabled**, the CPU prefetches both cache lines for 128 bytes as comprised.

MPS and ACPI MADT Ordering

This feature allows the user to configure the MPS (Multi-Processor Specifications) and ACPI settings for your motherboard. Select Modern Ordering if XP or a newer version of Windows OS is used in the motherboard. Select Legacy Ordering if 2000 or an earlier version is used. The options are **Modern Ordering** and Legacy Ordering.

Max CPUID Value Limit

This feature allows the user to set the maximum CPU ID value. Enable this feature to boot the legacy operating systems that cannot support processors with extended CPUID functions. The options are Enabled and **Disabled** (for the Windows OS).

Intel® Virtualization Technology (Available when supported by the CPU)

Select Enabled to enable Virtualization Technology support which will allow one platform to run multiple operating systems and applications in independent partitions, creating multiple "virtual" systems in one physical computer. The options are **Enabled** and Disabled. **Note:** If there is any change to this setting, you will need to power off and restart the system for the change to take effect. Please refer to Intel's website for detailed information.

Execute-Disable Bit Capability (Available when supported by the OS and the CPU)

Select Enabled to enable the Execute Disable Bit support which will allow the processor to designate areas in the system memory where an application code can execute and where it cannot, thus preventing a worm or a virus from flooding illegal codes to overwhelm the processor or damaging the system during an attack. The default is **Enabled**. (Refer to Intel and Microsoft websites for more information.)

CPU Multi-Core Enable/Disable (Available when supported by the CPU)

Select Enabled to enable multi-core CPU support to enhance CPU performance. The options are Disabled and **Enabled**.

A20M

When the A20M# pin is enabled, it will force address bit 20 to zero (to be masked) to emulate the address wraparound for the real-address mode at 1 MB. Set this item to Enabled for the legacy operating systems and applications that require A20M support to work properly. The options are Enabled and **Disabled**.

Intel® SpeedStep™ Technology

Intel EIST (Enhanced Intel SpeedStep Technology) allows the system to automatically adjust the processor voltage and core frequency in an effort to reduce power consumption and heat dissipation. Please refer to Intel's website for detailed information. The options are Disable (Disable GV3) and **Enable (Enable GV3)**.

Intel® TurboMode Tech (Available when Intel EIST Technology is enabled)

Select Enabled to use the TurboMode Technique to boost system performance. The options are **Enabled** and Disabled.

Performance/Wait Select

Use this feature to balance the need between system performance and energy saving. The options are **Traditional** and Power Optimized (for energy saving).

Intel® C-STATE Tech

If this feature is enabled, C-State is set by the system automatically to either C2, C3 or C4 state. The options are Disabled and **Enabled**. If this feature is set to Enabled, the following items will display.

C-State Package Limit Setting

If this feature is set to Auto, the AMI BIOS will automatically set the limit on the C-State package register. The options are **Auto**, C1, C3, C6 and C7.

C1 Auto Demotion

Select Enabled to allow the CPU to demote C3, C6, or C7 requests to C1 based on un-core auto-demote information. The options are Disabled and **Enabled**.

C3 Auto Demotion

If this feature is set to Enabled, the CPU will conditionally demote C6 or C7 requests to C3 based on un-core auto-demote information. The options are Disabled and **Enabled**.

ACPI T State

When this feature is enabled, CPU Throttling state will be reported in the ACPI (Advanced Configuration and Power Interface) protocol. The options are **Enabled** and Disabled.

► Advanced Chipset Control

The items included in the Advanced Settings submenu are listed below.

► CPU Bridge Configuration

► QPI Configuration

QuickPath Interconnect (QPI) is the connection between the CPU and the motherboard's I/O hub. This section displays the following QPI items.

MMConfigBase

This item is used to select the space-based address for memory_mapped configuration. The options are **0x8000 0000**, 0x4000 0000, and 0xC000 0000.

MMIOH Size Per IOH

Use this feature to select the memory_mapped IOH size to be allocated to each IOH. The options are **2G**, 4G, 6G, and 8G.

Logical Interrupt Mode

This item is used to select the logical interrupt mode. The options are **Flat Mode** and Cluster Mode.

Cluster Mode Check Sampling

Select Enabled to check if the APICID in an IntPriUpd message is not zero. The options are **Enabled** and Disabled.

QPI Debug Message Output Level

This feature allows the user to decide the level of an QPI debug message to be sent to the user. The options are **Err/Warn/Info0/1**, Err/Warn/Info0, and Err/Warn.

CRC Mode

Use this feature to select the QPI CRC (Cyclic Redundancy Check) mode, which will determine how often the raw computer data stored in a network or a hard disk device is checked for CRC. The options are **8Bit CRC** and 16Bit Rolling CRC.

QPI (Quick Path Interconnect) Links Speed

Use this feature to set data transfer speed for QPI Link connections. The options are Slow and **Fast**.

QPI Frequency Select (Available if the item - QPI Link Speed is set to Fast)

This feature is used to set desired QPI frequency. The options are 4.800 GT, 5.866GT, 6.400 GT and **Auto**.

QPI Scrambling

Select Enabled to enable Bit-Shuffling support which will allow bits in the data flow to be shifted around for CRC checking during data transmission and receiving between the CPUs or between a CPU and an IO hub (IOH). The options are **Enabled** and Disabled.

► Integrated Memory Controller Configuration

Interleave Type

Use this feature to select memory interleaving mode. Select Inter-Socket Block Interleaving to enable memory interleaving between blocks of memory installed in different DIMM slots. Select Intra-Socket Block Interleaving to enable memory interleaving between blocks of memory installed in the same DIMM slot. Select Automatic to allow BIOS to automatically select the memory interleaving mode for memory modules installed in the system. The options are No Interleaving, **Inter-Socket Block Interleaving**, Intra-Socket Block Interleaving, and Automatic.

Interleave Order

Use this feature to set the order of memory interleaving. The options are High Only, High Low, **Low High 0**, and Low High 1.

Mirroring

Mirroring support allows data stored in one location to be copied into another location for data redundancy and security. The options are listed below:

- **No Mirroring** (Mirroring Disabled),
 - Intra-Socket Mirrored Nx1 to Nx3 (Memory Controller 1 to Memory Controller 3 of the same DIMM socket),
 - Intra-Socket Mirrored Nx3 to Nx1 (Memory Controller 3 to Memory Controller 1 of the same DIMM socket),
 - Inter-Socket Mirrored S0 (Socket 0) to S1 (Socket 1), and S2 (Socket 2) to S3 (Socket 3),
-

- Inter-Socket Mirrored S0 (Socket 0) to S2 (Socket 2) and S1 (Socket 1) to S3 (Socket 3),
- Inter-Socket Mirrored S0 (Socket 0) to S3 (Socket 3) and S1 (Socket 1) to S2 (Socket 2).

Spare Enable

Select Enabled to enable spare support for all sockets, creating a spare drive for each socket. The options are Enabled and **Disabled**.

Mapper Mode

Use this feature to set the memory_mapper mode, which is used to translate local physical addresses presented by a media device into DRAM memory addresses (in terms of rank, bank, row and column). Select Open to maximize open_page hits. Select Close to minimize rank conflicts and to maximize simultaneous read/write bandwidth to boost performance. Select Adaptive to spread power dissipation over different DIMM modules to avoid memory overheat. The options are **Close**, Open and Adaptive.

Frequency Limit

This feature forces a DDR3 memory module to run at a frequency other than what the system has detected. The available options are **Auto**, 800 MHz, 978 MHz, 1067 MHz, and **Auto**.

Initialization Mode

Use this feature to select the memory initialization mode. The options are Serial and **Parallel**.

Hemisphere Mode

This feature is used to set the memory hemisphere mode. Select Enabled to prevent CPU's cache agent 1 from accessing cache agent 2 in an effort to reduce memory latency and maximize performance. This setting requires that both DIMM modules and DRAM sizes are configured in the same way. Select Disabled to allow a CPU's cache agent 1 to access cache agent 2. The options are Disabled and **Enabled**.

Page Policy

Use this feature to configure Page Policy settings, which determine how memory blocks are cached in a DRAM buffer and a memory module accesses memory resources. Select Open to optimize memory performance. Select Close to use memory safe mode. Select Adaptive to balance safety and performance. The options are Close, **Open** and Adaptive.

Scheduler Policy

Use this feature to configure Scheduler_Policy settings. The scheduler is used to translate memory read/write commands into memory sub-commands for easy execution. Select Static Trade_Off to balance read/write priority. Select Static Read_Priority to optimize read latency and bandwidth. Select Static Write_Priority to optimize write bandwidth to expedite command writing and execution. Select Adaptive to minimize latency. The options are Static Trade_Off, Static Read_Priority, Static Write_Priority, and **Adaptive**.

ECC Check Time Interval

This feature is used to set the time interval between each ECC Memory checking. If an ECC error occurs, an error message will also be sent via IPMI. The options are 100 Msec, 1 Sec, 10 Sec, 1 Min, **5 Minutes**, and 10 Minutes.

►North Bridge Configuration

This feature allows the user to configure North Bridge settings.

Relaxed Ordering

Select Enabled to enable PCI-Express Relaxed_Ordering support which will allow certain transactions to be executed first by passing other transactions that were issued earlier, violating the strict PCI-E ordering rules. The options are **Auto**, Disabled and Enabled.

Maximum Payload Size

This feature is used to set the maximum payload size for a PCI-Express device. Please refer to your add-on card user guide for the desired setting. The options are **Auto**, 128 Bytes, 256 Bytes, 512 Bytes, 1024 Bytes, 2048 Bytes, 4096 Bytes, and Maximum supported.

Extended Tag Field

Select Enabled to use the 8-bit Tag field of a device as a requester. The options are **Auto**, Disabled and Enabled.

No Snoop

If this feature is set to Enabled, No_Snoop option for a PCI-Express device will be enabled. The options are **Auto**, Disabled and Enabled.

Maximum Read Request Size

This feature is used to set the maximum read request size for a PCI-Express device. The options are **Auto**, 128 Bytes, 256 Bytes, 512 Bytes, 1024 Bytes, 2048 Bytes, 4096 Bytes, and Maximum supported.

Active State Power Management

Select Enabled to use the power management for signal transactions between the PCI Express L0 and L1 Links. Select Enabled to configure PCI-Exp. L0 and L1 Link power states. The options are **Disabled** and Enabled.

Extended Synch

Select Enabled to generate extended synchronization patterns. The options are **Auto**, Disabled and Enabled.

Intel VT-d

Select Enabled to enable Intel Virtualization Technology support for Direct I/O VT-d by reporting the I/O device assignments to VMM through the DMAR ACPI Tables. This feature offers fully-protected I/O resource-sharing across the Intel platforms, providing the user with greater reliability, security and availability in networking and data-sharing. The settings are Enabled and **Disabled**.

Thermal Sensor

Select Enabled to activate the thermal sensor. The options are **Disabled** and Enabled.

► South Bridge Configuration

This feature allows the user to configure Intel ICH South Bridge settings.

USB Functions

This feature allows the user to decide the number of onboard USB ports to be enabled. The Options are: Disabled, 2 USB Ports, 4 USB Ports, 6 USB Ports, 8 USB Ports, 10 USB Ports, and **12 USB Ports**. (If this item is set to Enabled, USB 2.0 Controller will be enabled.)

USB Port Configuration

This feature is used to configure USB port settings. The Options are: **6x6 USB** Ports and 8x4 USB Ports.

USB 2.0 Controller

Select Enabled to activate the USB 2.0 Controller. The options are **Enabled** and Disabled. (**Note:** If the item - USB Functions is enabled, USB 2.0 Controller will always be enabled. When the item - USB Functions is set to Disabled, the user has the option to enable or disable USB 2.0 Controller.)

HDA Controller

Select Enabled to enable the High-Definition Audio Controller. The settings are **Enabled** and Disabled.

SMBUS Controller

Select Enabled to enable the System_Management Bus Controller. The settings are **Enabled** and Disabled.

SLP_S4# Min. Assertion Width

This feature allows the user to set the minimum SLP_S4# Assertion Width to make sure that DRAMs have safe power cycles. The settings are **4 to 5 seconds**, 3 to 4 Seconds, 2 to 3 Seconds, and 1 to 2 Seconds.

Restore on AC Power Loss

Use this feature to set the power state after a power outage. Select Power-Off for the system power to remain off after a power outage. Select Power-On for the system power to be turned on after a power outage. Select Last State to allow the system to resume its last state before the power outage. The options are Power-On, Power-Off and **Last State**.

SATA Master Break Event

If this feature is set to Enabled, activities on the SATA master drive will break from the C3/C6 state. The settings are Enabled and **Disabled**.

PCIE Ports Configuration

PCIE Port 0 ~ PCIE Port 4

This feature is used to configure PCI-E port settings. Select Auto to allow a specified PCIE port to be enabled if a PCIE device is detected. The settings are **Auto**, Enabled and Disabled.

PCIE High Priority Port

This feature allows the user to select the PCIE High Priority port. The settings are **Disabled**, Port 0, Port 1, Port 2, Port 3, Port 4, and Port 5.

PCIE Port 0 IOxAPIC Enable ~ PCIE Port 4 IOxAPIC Enable

Select Enable to enable IOxAPIC support for a PCIE port specified. The settings are Enabled and **Disabled**.

► IDE/SATA Configuration

When this submenu is selected, the AMI BIOS will automatically detect the presence of the IDE/SATA devices, and displays the following items.

SATA#1 Configuration

If Compatible is selected, it sets SATA#1 to the legacy_compatible mode. Selecting Enhanced sets SATA#1 to the native SATA mode. The options are Disabled, Compatible and **Enhanced**.

Configure SATA#1 as (Not available when SATA#1 Configuration is disabled)

Use this feature to select the drive type for SATA#1. The options are **IDE**, RAID and AHCI. (When the option-RAID is selected, the item-ICH RAID Code Base will appear. When the option-AHCI is selected, the item-ICH AHCI Codebase will be available.)

ICH RAID Code Base (Available when the option-RAID is selected.)

Select Intel to use Intel's SATA RAID firmware to configure Intel's SATA RAID settings. Select Adaptec to use Adaptec's SATA RAID firmware to configure Adaptec's SATA RAID settings. The options are **Intel** and Adaptec.

ICH AHCI Codebase (Available when the option-AHCI is selected.)

Use this feature to select the AHCI Codebase for the ICH South Bridge. The options are BIOS Native Module and **Intel AHCI ROM**.

SATA#2 Configuration (Available when the option-IDE is selected.)

Select Enhanced to set SATA#2 to Native SATA mode. The options are Disabled and **Enhanced**.

Primary IDE Master/Slave, Secondary IDE Master/Slave, Third IDE Master, and Fourth IDE Master

These settings allow the user to set the parameters for the slots indicated above. Press <Enter> to activate the following submenu items. Set the correct configurations accordingly. The items included in the submenu are listed below.

Type

Use this item to select the type of device connected to the system. The options are Not Installed, **Auto**, CD/DVD and ARMD.

LBA/Large Mode

LBA (Logical Block Addressing) is a method of addressing data on a disk drive. In the LBA mode, the maximum drive capacity is 137 GB. For drive capacities over 137 GB, your system must support a 48-bit LBA mode. If not, contact your manufacturer or install an ATA/133 IDE controller card that supports 48-bit LBA mode. The options are Disabled and **Auto**.

Block (Multi-Sector Transfer)

Block Mode boosts the IDE drive performance by increasing the amount of data transferred. Only 512 bytes of data can be transferred per interrupt if Block Mode is not used. Block Mode supports transfers of up to 64 KB per interrupt. Select Disabled to allow data to be transferred from and to a device one sector at a time. Select Auto to allow data transfer from and to a device multiple sectors at a time if the device supports it. The options are **Auto** and Disabled.

PIO Mode

The IDE PIO (Programmable I/O) Mode programs timing cycles between the IDE drive and the programmable IDE controller. As the PIO mode increases, the cycle time decreases. The options are **Auto**, 0, 1, 2, 3, and 4.

Select Auto to allow AMI BIOS to automatically detect the PIO mode. Use this value if the IDE disk drive support cannot be determined.

Select 0 to allow AMI BIOS to use PIO mode 0. It has a data transfer rate of 3.3 MB/s.

Select 1 to allow AMI BIOS to use PIO mode 1. It has a data transfer rate of 5.2 MB/s.

Select 2 to allow AMI BIOS to use PIO mode 2. It has a data transfer rate of 8.3 MB/s.

Select 3 to allow AMI BIOS to use PIO mode 3. It has a data transfer rate of 11.1 MB/s.

Select 4 to allow AMI BIOS to use PIO mode 4. It has a data transfer bandwidth of 32-Bits. Select Enabled to enable 32-Bit data transfer.

Select UDMA5 to allow BIOS to use Ultra DMA mode 5. It has a data transfer rate of 133 MB/s.

Select UDMA6 to allow BIOS to use Ultra DMA mode 6. It has a data transfer rate of 133 MB/s. The options are **Auto**, SWDMAn, MWDMAAn, and UDMAAn.

DMA Mode

Select Auto to allow BIOS to automatically detect IDE DMA mode when IDE disk drive support cannot be determined.

Select SWDMA0 to allow BIOS to use Single Word DMA mode 0. It has a data transfer rate of 2.1 MB/s.

Select SWDMA1 to allow BIOS to use Single Word DMA mode 1. It has a data transfer rate of 4.2 MB/s.

Select SWDMA2 to allow BIOS to use Single Word DMA mode 2. It has a data transfer rate of 8.3 MB/s.

Select MWDMA0 to allow BIOS to use Multi-Word DMA mode 0. It has a data transfer rate of 4.2 MB/s.

Select MWDMA1 to allow BIOS to use Multi-Word DMA mode 1. It has a data transfer rate of 13.3 MB/s.

Select MWDMA2 to allow BIOS to use Multi-Word DMA mode 2. It has a data transfer rate of 16.6 MB/s.

Select UDMA0 to allow BIOS to use Ultra DMA mode 0. It has a data transfer rate of 16.6 MB/s. It has the same transfer rate as PIO mode 4 and Multi-Word DMA mode 2.

Select UDMA1 to allow BIOS to use Ultra DMA mode 1. It has a data transfer rate of 25 MB/s.

Select UDMA2 to allow BIOS to use Ultra DMA mode 2. It has a data transfer rate of 33.3 MB/s.

Select UDMA3 to allow BIOS to use Ultra DMA mode 3. It has a data transfer rate of 44.4 MB/s.

Select UDMA4 to allow BIOS to use Ultra DMA mode 4. It has a data transfer rate of 66.6 MB/s.

Select UDMA5 to allow BIOS to use Ultra DMA mode 5. It has a data transfer rate of 100 MB/s.

Select UDMA6 to allow BIOS to use Ultra DMA mode 6. It has a data transfer rate of 133 MB/s. The options are **Auto**, SWDMAn, MWDMAAn, and UDMAAn.

S.M.A.R.T. For Hard disk drives

Self-Monitoring Analysis and Reporting Technology (SMART) can help predict impending hard disk drive failures. Select Auto to allow AMI BIOS to automatically detect hard disk drive support. Select Disabled to prevent AMI BIOS from using the S.M.A.R.T. Select Enabled to allow AMI BIOS to use the S.M.A.R.T. to support hard drive disk. The options are Disabled, Enabled and **Auto**.

32Bit Data Transfer

Select Enabled to support 32-bit IDE data transfer. The options are **Enabled** and Disabled.

Hard Disk Write Protect

Select Enabled to support Hard Disk Write Protect to prevent data from being written to a hard drive. The options are Enabled or **Disabled**.

IDE Detect Timeout (sec)

Use this feature to set the timeout value to allow BIOS to detect the ATA, ATAPI devices installed in the system. The options are 0 (sec), 5, 10, 15, 20, 25, 30, and

► PCI/PnP Configuration

Clear NVRAM

Select Yes to clear Non-Volatile Random Access (Flash) Memory (NVRAM) during system boot. The options are **No** and Yes.

Plug & Play OS

Select Yes to allow the OS to configure Plug & Play devices. (This is not required for system boot if your system has an OS that supports Plug & Play.) Select **No** to allow AMI BIOS to configure all devices in the system.

PCI Latency Timer

This feature sets the PCI Latency Timer for each PCI device installed on a PCI bus. Select 64 to set the PCI Latency Timer to 64 PCI clock cycles. The options are 32, **64**, 96, 128, 160, 192, 224 and 248.

Palette Snooping

Select Enabled to allow BIOS to inform PCI-E devices that an ISA graphics device is installed in the system so that the ISA graphics card can function properly. The options are **Disabled** and Enabled.

SR-IOV Supported

Single Root I/O Virtualization is an industry-standard mechanism that allows devices to be shared simultaneously among several virtual machines. SR-IOV is capable of partitioning a PCI device into several virtual interfaces in order to share the resources of a PCI Express (PCIe) device under a virtual environment. The options are **Disabled** and Enabled.

Onboard VGA Device

Select Enabled to use VGA devices. The options are Disabled and **Enabled**.

Boot Graphic Adapter Priority

This feature selects the graphics adapter to be used as the primary boot device. The options are **Auto** and Onboard VGA Device.

Onboard SAS OPROM

Select Enabled to enable Onboard SAS Option ROM which will allow you to boot the computer using a SAS device. The options are **Enabled** and Disabled.

Onboard LAN Option ROM Select

Select iSCSI to use iSCSI Option ROMs to boot the computer. Select PXE to use PXE Option ROMs to boot the computer. The options are iSCSI and **PXE**.

LAN1 Option ROM/LAN2 Option ROM

Select Enabled to enable the onboard LAN1/LAN2 Option ROMs to boot the computer using a network interface. The options are Enabled and **Disabled**.

► Super IO Device Configuration

Serial Port1 Address/IRQ, Serial Port2 Address/IRQ

This option specifies the base I/O port address and the Interrupt Request address for Serial Port 1 and Serial Port 2. Select Disabled to prevent the serial port from accessing any system resources. When this option is set to Disabled, the serial port physically becomes unavailable. Select 3F8/IRQ4 to allow the serial port to use 3F8 as its I/O port address and IRQ 4 for the interrupt address. The options for Serial Port1 are Disabled, **3F8/IRQ4**, 3E8/IRQ4, 2E8/IRQ3 and 2F8/IRQ3. The options for Serial Port2 are Disabled, **2F8/IRQ3**, 3E8/IRQ4, 3F8/IRQ4, and 2E8/IRQ3.

► USB Configuration

This feature allows the user to configure USB settings for the motherboard.

Legacy USB Support

Select Enabled to use Legacy USB devices. If this item is set to Auto, Legacy USB support will be automatically enabled if a legacy USB device is installed on the motherboard, and vice versa. The settings are Disabled, **Enabled** and Auto.

Port60h/64h Emulation

Select Enabled to enable 60h/64h emulation so that a USB keyboard can be supported by an operating system that is not compatible with USB devices. The options are Enabled and **Disabled**.

USB 2.0 Controller Mode

This setting allows you to select USB 2.0 Controller mode. The options are **Hi-Speed (480 Mbps)** and Full Speed (12 Mbps).

BIOS EHCI Hand-Off

Select Enabled to support BIOS Enhanced Host Controller Interface to provide a workaround solution for an operating system that does not support EHCI Hand-Off technology. When this item is enabled, the EHCI Interface will be changed from the BIOS-controlled to the OS-controlled. The options are Disabled and **Enabled**.

Legacy USB1.1 HC Support

Select Enabled to enable Legacy USB 1.1 HC support. The settings are Disabled and **Enabled**.

Hot-Plug USB FDD Support

When this item is set to Enabled, a dummy Floppy Device Drive will be created as a Hot-Plug Floppy device in the system. When this item is set to **Auto**, a dummy floppy device will not be created if no USB FDD device is detected. The options are Disabled, Enabled and **Auto**.

►ACPI Configuration

Use this feature to configure Advanced Configuration and Power Interface (ACPI) power management settings for your system.

►Advanced ACPI Configuration

This feature allows the user to configure Advanced ACPI (Advanced Configuration and Power Interface) settings.

ACPI Version Features

Use this feature to select the ACPI version to be used in the system. The options are ACPI v1.0, **ACPI v2.0** and ACPI v3.0. Please refer to ACPI's website for further explanation: <http://www.acpi.info/>.

ACPI APIC Support

Select Enabled to include the ACPI APIC Table Pointer in the RSDT (Root System Description Table) pointer list. The options are **Enabled** and Disabled.

AMI OEMB Table

Select Enabled to include the OEMB Table Pointer in the RSDT (Root System Description Table) pointer list. The options are **Enabled** and Disabled.

Headless Mode (Available ACPI Aware O/S='Yes')

This feature is used to enable system to function without a keyboard, monitor or mouse attached. The options are Enabled and **Disabled**.

NUMA Support

Select Enabled to enable Non-Uniform Memory Access support to improve CPU performance for a system that has an OS with NUMA support. The options are **Enabled** and Disabled.

►Chipset ACPI Configuration

This feature is used to configure Chipset ACPI (Advanced Configuration and Power Interface) settings.

Energy Lake Feature

Select Enabled to use Intel Energy Lake technology to enhance power efficiency. The options are **Disabled** and Enabled.

APIC ACPI SCI IRQ

When this item is set to Enabled, APIC ACPI SCI IRQ is supported by the system. The options are Enabled and **Disabled**.

USB Device Wakeup From S3/S4

Select Enable to wake up the system via a USB device when the system is in S3 or S4 State. The options are Enabled and **Disabled**.

High Precise Event Timer

Select Enabled to activate the High Precise Event Timer (HPET) to produce periodic interrupts at a much higher frequency than a Real-time Clock (RTC) does in synchronizing multimedia streams, providing smooth playback and reducing the dependency on other timestamp calculation devices, such as an x86 RDTSC Instruction embedded in the CPU. The High Performance Event Timer is used to replace the 8254 Programmable Interval Timer. The options are Enabled and **Disabled**.

► General WHEA Configuration

WHEA Support

Select Enabled to support the Windows Hardware Error Architecture (WHEA) platform and provide a common infrastructure for the system to handle hardware errors within the Windows OS environment to reduce system crashes and to enhance system recovery and health monitoring. The options are **Enabled** and Disabled.

► Event Log Configuration

View Event Log

Use this option to view the System Event Log.

Mark All Events as Read

This option marks all events as read. The options are **OK** and Cancel.

Clear Event Log

This option clears the Event Log memory of all messages. The options are **OK** and **Cancel**.

► Hardware Health Event Monitoring

This feature is used to monitor system health and review the status of each item as displayed.

CPU Overheat Alarm

This option allows the user to select the CPU Overheat Alarm setting which determines when the CPU OH alarm will be activated to provide warning of possible CPU overheat.

Warning! 1. Any temperature that exceeds the CPU threshold temperature predefined by the CPU manufacturer may result in CPU overheat or system instability. When the CPU temperature reaches this predefined threshold, the CPU and system cooling fans will run at full speed. 2. To avoid possible system overheating, please be sure to provide adequate airflow to your system.

The options are:

- **The Early Alarm:** Select this setting if you want the CPU overheat alarm (including the LED and the buzzer) to be triggered as soon as the CPU temperature reaches the CPU overheat threshold as predefined by the CPU manufacturer.
- **The Default Alarm:** Select this setting if you want the CPU overheat alarm (including the LED and the buzzer) to be triggered when the CPU temperature reaches about 5°C above the threshold temperature as predefined by the CPU manufacturer to give the CPU and system fans additional time needed for CPU and system cooling. In both the alarms above, please take immediate action as shown below.

CPU 1 Temperature ~ CPU 4 Temperature/System Temperature 1 Reading~ System Temperature 4 Reading

This feature displays current temperature readings for the CPU and the System as specified above.

The following items will be displayed for your reference only:

CPU 1 Temperature ~ CPU 4 Temperature

The CPU thermal technology that reports absolute temperatures (Celsius/Fahrenheit) has been upgraded to a more advanced feature by Intel in its newer processors. The basic concept is each CPU is embedded by unique temperature information that the motherboard can read. This 'Temperature Threshold' or 'Temperature Tolerance' has been assigned at the factory and is the baseline on which the motherboard takes action during different CPU temperature conditions (i.e., by increasing CPU Fan speed, triggering the Overheat Alarm, etc). Since CPUs can have different 'Temperature Tolerances', the installed CPU can now send informa-

tion to the motherboard what its 'Temperature Tolerance' is, and not the other way around. This results in better CPU thermal management.

Supermicro has leveraged this feature by assigning a temperature status to certain thermal conditions in the processor (Low, Medium and High). This makes it easier for the user to understand the CPU's temperature status, rather than by just simply seeing a temperature reading (i.e., 25°C). The CPU Temperature feature will display the CPU temperature status as detected by the BIOS:

Low – This level is considered as the 'normal' operating state. The CPU temperature is well below the CPU 'Temperature Tolerance'. The motherboard fans and CPU will run normally as configured in the BIOS (Fan Speed Control).

User intervention: No action required.

Medium – The processor is running warmer. This is a 'precautionary' level and generally means that there may be factors contributing to this condition, but the CPU is still within its normal operating state and below the CPU 'Temperature Tolerance'. The motherboard fans and CPU will run normally as configured in the BIOS. The fans may adjust to a faster speed depending on the Fan Speed Control settings.

User intervention: No action is required. However, consider checking the CPU fans and the chassis ventilation for blockage.

High – The processor is running hot. This is a 'caution' level since the CPU's 'Temperature Tolerance' has been reached (or has been exceeded) and may activate an overheat alarm.

User intervention: If the system buzzer and Overheat LED has activated, take action immediately by checking the system fans, chassis ventilation and room temperature to correct any problems.

 **Notes:** 1. The system may shut down if it continues for a long period to prevent damage to the CPU.

2. The information provided above is for your reference only. For more information on thermal management, please refer to Intel's _ at www.Intel.com.

System Temperature 1 Reading ~ System Temperature 4 Reading

The system temperature as specified above will be displayed (in degrees in Celsius and Fahrenheit) as it is detected by the BIOS.

Fan 1 Speed ~ Fan 11 Speed

This feature displays the fan speed readings from fan interfaces Fan 1 through Fan 10.

Fan Speed Control Modes

This feature allows the user to decide how the system controls the speeds of the onboard fans. The CPU temperature and the fan speed are correlative. When the CPU on-die temperature increases, the fan speed will also increase for effective system cooling. Select "Full Speed/FS" to allow the onboard fans to run at full speed for maximum cooling. The FS setting is recommended for special system configuration or debugging. Select "Performance/PF" for better system cooling. The PF setting is recommended for high-power-consuming and high-density systems. Select "Balanced/BL" for the onboard fans to run at a speed that will balance the needs between system cooling and power saving. The BL setting is recommended for regular systems with normal hardware configurations. Select "Energy Saving/ES" for best power efficiency and maximum quietness. The Options are: Full Speed/FS, Performance/PF, **Balanced/BL**, and Energy Saving/ES.

Voltage Monitoring

CPU1 Vcore, CPU2 Vcore, CPU3 Vcore, CPU4 Vcore, +1.0V, +1.2V, +1.8V, +1.1V, +12V, 1.5V, 3.3V V, 3.3VSB, Battery Voltage, and IOPV12.

►IPMI Configuration

Intelligent Platform Management Interface (IPMI) is a set of common interfaces that IT administrators uses to monitor system health and to manage the system as a whole. For more information on the IPMI specifications, please visit Intel's website at www.intel.com.

Status of BMC

The Baseboard Management Controller (BMC) manages the interface between system management software and platform hardware. This item displays the status of the current BMC controller.

IPMI Firmware Version

This item displays the current IPMI Firmware Version.

►View BMC System Event Log

This feature displays the BMC System Event Log (SEL). It shows the total number of entries of BMC System Events. To view an event, select an Entry Number and press <Enter> to display the information as shown in the screen.

- Total Number of Entries
- SEL Record ID
- SEL Record Type

- Event Timestamp
- Generator ID
- Event Message Format Ver.
- Event Sensor Type
- Event Sensor Number
- Event Dir Type
- Event Data.

Clear BMC System Event Log

Clear BMC System Log now

Select OK and press <Enter> to clear the BMC system log immediately. Select Cancel to keep the BMC System log. The options are **OK** and **Cancel**.



Caution: Any cleared information is unrecoverable. Make absolutely sure that you will no longer need any data stored in the log before clearing the BMC Event Log.

► Set LAN Configuration

This feature allows the user to configure the IPMI LAN adapter with a network address as shown in the following graphics.

Channel Number - This feature displays the channel number.

Channel Number Status - This feature returns the channel status for the Channel Number selected above: "Channel Number is OK" or "Wrong Channel Number".

► IP Address

Parameter Selector

This item displays the status of the IP Address Parameter Selector.

IP Address Source

This features allows the user to select how an IP address is assigned to a client computer or network device. Select DHCP (Dynamic Host Configuration Protocol) to allow a client (computer or device) to obtain an IP address from a DHCP server that manages a pool of IP addresses and network information on

a "request and grant" basis. Upon timeout (or lease expiration), the IP address assigned to the client can be reassigned to a new client. Select Static (Static Allocation) to allow the host server to allocate an IP address based on a table containing MAC Address/IP Address pairs that are manually entered (probably by a network administrator). Only clients with a MAC address listed in the MAC/IP Address Table will be assigned an IP address. The IP Address allocated to the client is on a longer term basis than that assigned by the DHCP mentioned in the other option. The options are **DHCP** and Static.

IP Address

The BIOS will automatically enter the IP address for this machine; however it may be overwritten. The value of each three-digit number separated by dots should not exceed 255.

Current IP Address in BMC

The BIOS will automatically enter the current IP address in BMC for this machine; however it may be overwritten. The value of each three-digit number separated by dots should not exceed 255.

► MAC Address Configuration

Parameter Selector

This item displays the status of the MAC Address Parameter Selector.

Current Mac Address in BMC

The BIOS will automatically enter the current Mac address in BMC for this machine; however it may be overwritten. Mac addresses are 6 two-digit hexadecimal numbers (Base 16, 0 ~ 9, A, B, C, D, E, F) separated by dots. (i.e., 00.30.48.D0.D4.60).

► Subnet Mask Configuration

Parameter Selector

This item displays the status of the Parameter Selector.

Subnet Mask

This item displays the current subnet mask setting for your IPMI connection. The value of each three-digit number separated by dots should not exceed 255.

Current Subnet Mask in BMC

The BIOS will automatically enter the current subnet mask in BMC for this machine; however it may be overwritten. The value of each three-digit number separated by dots should not exceed 255.

► Gateway Address

Parameter Selector

This item displays the status of the Gateway Address Parameter Selector.

Gateway Address

The BIOS will automatically enter the Gateway address of this machine; however it may be overwritten. The value of each three-digit number separated by dots should not exceed 255.

Current IP Address in BMC

The BIOS will automatically enter the current IP address in BMC for this machine; however it may be overwritten. The value of each three-digit number separated by dots should not exceed 255.

► Remote Access Configuration

Remote Access

This allows the user to enable the Remote Access support. The options are Disabled and **Enabled**. If Remote Access is set to Enabled, the following items will display:

Serial Port Number

This feature allows the user to decide which serial port to use for Console Redirection. The options are COM 1 and **COM 2**.

Base Address, IRQ

This item displays the based address and IRQ of the serial port specified.

Serial Port Mode

Use this item to set the serial port mode for Console Redirection. The options are **115200 8, n 1**; 57600 8, n, 1; 38400 8, n, 1; 19200 8, n, 1; and 9600 8, n, 1.

Flow Control

This feature allows the user to set the flow control for Console Redirection. The options are **None**, Hardware, and Software.

Redirection After BIOS POST

Select Disabled to turn off Console Redirection after Power-On Self-Test (POST). Select Always to keep Console Redirection active all the time after POST. (**Note:** This setting may not be supported by some operating systems.) Select Boot Loader to keep Console Redirection active during POST and Boot Loader. The options are Disabled, Boot Loader, and **Always**.

Terminal Type

This feature allows the user to select the target terminal type for Console Redirection. The options are **ANSI**, VT100, and VT-UTF8.

VT-UTF8 Combo Key Support

A terminal keyboard definition that provides a way to send commands from a remote console. The options are **Enabled** and Disabled.

Sredir Memory Display Delay

This feature defines the length of time in seconds to display memory information. The options are **No Delay**, Delay 1 Sec, Delay 2 Sec, and Delay 4 Sec.

► Trusted Computing (Optional)

TCG/TPM Support

Select Yes on this item and enable the TPM jumper on the motherboard to enable TCG (TPM 1.1/1.2)/TPM support to improve data integrity and network security. The options are **No** and Yes. If this feature is set to Yes, the following items will display.

Indicate Physical (Available when TCG/TPM Support = 'Yes')

Select Yes for BIOS to detect the presence of TPM devices at system boot. Select No to hide the presence of TPM devices at system boot. The options are Yes and **No**.

TPM Deactivated (Available when TCG/TPM Support = 'Yes')

Select Set to disable TPM support at bootup. Select Clear to activate the TPM devices to at bootup. Select Don't Change to keep the current TPM support status. The options are Set, Clear, and **Don't Change**.

TPM Owner (Available when TCG/TPM Support = 'Yes')

This feature allows the user to configure TPM Owner settings. The options are **Don't Change**, Enable Install, Disable Install, and Clear.

Execute TPM Command (Available when TCG/TPM Support = 'Yes')

Select Enabled to execute TPM commands you've selected. Select Don't Change to keep the current TPM commands without making any changes. Select Disabled to abandon the changes you have made on TPM commands. The options are Enabled, Disabled and **Don't Change**.

TPM Enable/Disable Status

This item displays the status of TPM Support to indicate if TPM is currently enabled or disabled.

TPM Owner Status

This item displays the status of TPM Ownership.

7-4 Boot Configuration

Use this feature to configure boot settings.

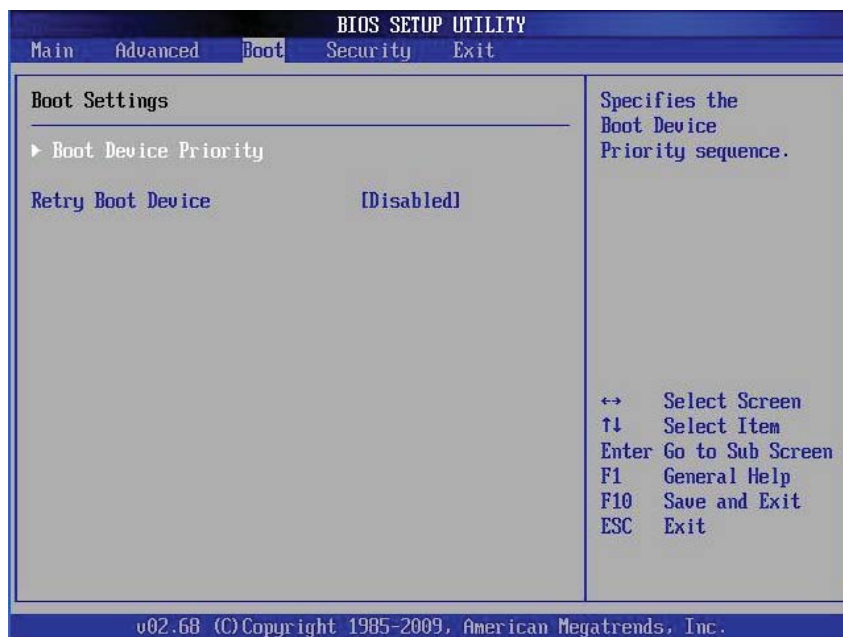

► Boot Device Priority

This feature allows the user to specify the sequence of priority for the Boot Device. The settings are 1st boot device, 2nd boot device, 3rd boot device, 4th boot device, 5th boot device and Disabled.

- 1st Boot Device - [SATA: XXXXXXXXXX]

► Hard Disk Drive, CD/DVD-ROM Drive, Removable Drive

This feature allows the user to specify the boot sequence from all available hard disk drives. The settings are Disabled and a list of all hard disk drives that have been detected (i.e., 1st Drive, 2nd Drive, 3rd Drive, etc).

- 1st Drive - [SATA: XXXXXXXXXX]

Retry Boot Devices

Select Enabled to enable Retry Boot Devices support to allow the system to attempt to boot from a specific boot device after a boot failure. The options are Enabled and **Disabled**.

7-5 Security Settings

The AMI BIOS provides a Supervisor and a User password. If you use both passwords, the Supervisor password must be set first.

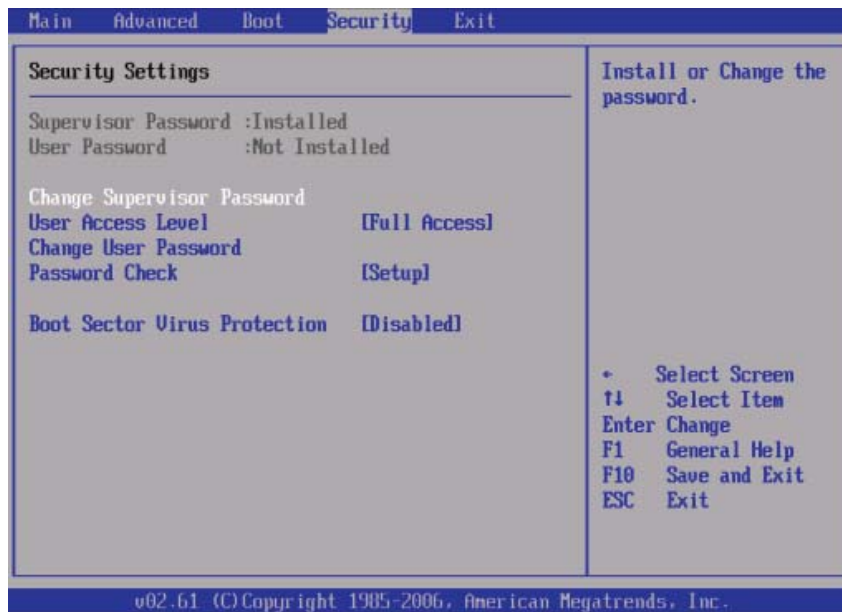

Supervisor Password

This item indicates if a Supervisor password has been entered for the system. "Not Installed" means a Supervisor password has not been used.

User Password

This item indicates if a user password has been entered for the system. "Not Installed" means that a user password has not been used.

Change Supervisor Password

Select this feature and press <Enter> to access the submenu, and then enter a new Supervisor Password.

User Access Level (Available when Supervisor Password is set as above)

Select **Full Access** to grant full User read and write access to the Setup Utility. Select **View Only** to allow the user to view the Setup Utility settings without changing the fields. Select **Limited** to allow the user to access and change limited fields such as Date and Time. Select **No Access** to prevent the user from accessing the Setup Utility.

Change User Password

Select this feature and press <Enter> to access the submenu and enter a new User Password.

Clear User Password (Available only when User Password has been set)

This item allows the user to clear a user password after it has been entered.

Password Check

Select Setup for the system to check for a password at Setup. Select Always for the system to check for a password at bootup. The options are **Setup** and Always.

Boot Sector Virus Protection

If this item is enabled, AMI BIOS displays a warning if any program (or virus) issues a Disk Format command or attempts to write to the boot sector of the hard disk drive. The options are Enabled and **Disabled**.

7-6 Exit Options

Select the Exit tab from the AMI BIOS Setup Utility screen to enter the Exit BIOS Setup screen.

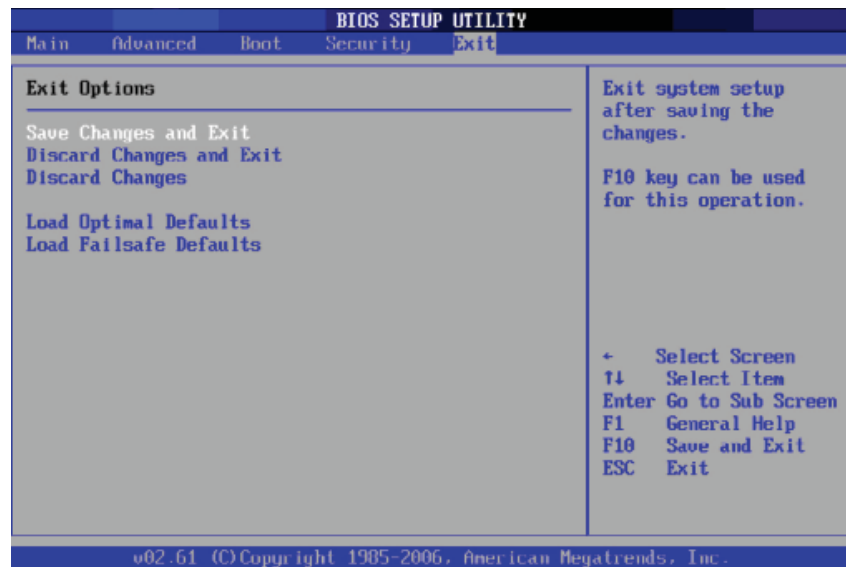

Save Changes and Exit

When you have completed the system configuration changes, select this option to leave the BIOS Setup Utility and reboot the computer so that the new system configuration parameters can take effect. Select Save Changes and Exit from the Exit menu and press <Enter>.

Discard Changes and Exit

Select this option to quit the BIOS Setup without making any permanent changes to the system configuration and reboot the computer. Select Discard Changes and Exit from the Exit menu and press <Enter>.

Discard Changes

Select this option and press <Enter> to discard all the changes and return to the AMI BIOS Utility Program.

Load Optimal Defaults

To set this feature, select Load Optimal Defaults from the Exit menu and press <Enter>. Then, select OK to allow the AMI BIOS to automatically load Optimal Defaults to the BIOS Settings. The Optimal settings are designed for maximum system performance but may not work best for all computer applications.

Load Fail-Safe Defaults

To set this feature, select Load Fail-Safe Defaults from the Exit menu and press <Enter>. The Fail-Safe settings are designed for maximum system stability but not for maximum performance.

Appendix A

BIOS Error Beep Codes

During the POST (Power-On Self-Test) routines, which are performed each time the system is powered on, errors may occur.

Non-fatal errors are those which, in most cases, allow the system to continue the boot-up process. The error messages normally appear on the screen.

Fatal errors will not allow the system to continue the boot-up procedure. If a fatal error occurs, you should consult with your system manufacturer for possible repairs.

These fatal errors are usually communicated through a series of audible beeps. The numbers on the fatal error list correspond to the number of beeps for the corresponding error.

BIOS Error Beep Codes		
Beep Code/LED	Error Message	Description
1 beep	Refresh	Circuits have been reset. (Ready to power up)
5 short beeps + 1 long beep	Memory error	No memory detected in the system
8 beeps	Display memory read/write error	Video adapter missing or with faulty memory
OH LED On	System OH	System Overheat

Notes

Appendix B

System Specifications

Processors

Four Intel Xeon MP 7500 Series processors in LGA1567 sockets

Note: Please refer to our web site for a complete listing of supported processors.

Chipset

Intel 7500/ICH10R

BIOS

64 Mb SPI AMI BIOS® SM Flash BIOS

Memory Capacity

Thirty-two DIMM slots supporting up to 1024 GB of registered ECC DDR3-1066/800 SDRAM

Note: See the memory section in Chapter 5 for details.

SATA Controller

Intel ICH10R controller for six SATA ports (RAID 0, 1 and 5 supported)

SAS Controller

LSI 2108 SAS controller for eight SAS ports (RAID 0, 1 and 5 supported) (8016B-6F only)

Drive Bays

Three hot-swap drive bays to house three standard SAS or SATA drives

Peripheral Drives/Bays

One slim DVD-ROM drive (optional)

Expansion Slots

Supports the use of one standard size PCI-Express x16 add-on card

Serverboard

8016B-6F: X8QB6-F (extended ATX form factor)

8016B-TF: X8QBE-F (extended ATX form factor)

Dimensions (both): 16.4" x 16.8" (416.6 x 426.7 mm)

Chassis

SC818A-1400B (1U rackmount)

Dimensions: (WxHxD) 17.2 x 1.7 x 27.75 in. (473 x 43 x 705 mm)

Weight

Gross (Bare Bone): 43 lbs. (19.5 kg.)

System Cooling

Six (6) paired sets of 4-cm counter-rotating cooling fans (fan speed controlled by BIOS setting)

System Input Requirements

AC Input Voltage: 100 - 240V AC auto-range

Rated Input Current: 11.5 - 5.5A max

Rated Input Frequency: 50 to 60 Hz

Power Supply

Rated Output Power: 1400W (Part# PWS-1K41P-1R) 80 Plus Gold Certified

Rated Output Voltages: +12V (91A @ 110V, 116A @ 180~240V), +5Vsb (4A @ 240V, 4A @ 100V)

Operating Environment

Operating Temperature: 10° to 35° C (50° to 95° F)

Non-operating Temperature: -40° to 70° C (-40° to 158° F)

Operating Relative Humidity: 20% to 95% (non-condensing)

Non-operating Relative Humidity: 5 to 95% (non-condensing)

Regulatory Compliance

Electromagnetic Emissions: FCC Class A, EN 55022 Class A, EN 61000-3-2/-3-3, CISPR 22 Class A

Electromagnetic Immunity: EN 55024/CISPR 24, (EN 61000-4-2, EN 61000-4-3, EN 61000-4-4, EN 61000-4-5, EN 61000-4-6, EN 61000-4-8, EN 61000-4-11)

Safety: CSA/EN/IEC/UL 60950-1 Compliant, UL or CSA Listed (USA and Canada), CE Marking (Europe)

California Best Management Practices Regulations for Perchlorate Materials:

This Perchlorate warning applies only to products containing CR (Manganese Dioxide) Lithium coin cells. "Perchlorate Material-special handling may apply. See www.dtsc.ca.gov/hazardouswaste/perchlorate"

(continued from front)

The products sold by Supermicro are not intended for and will not be used in life support systems, medical equipment, nuclear facilities or systems, aircraft, aircraft devices, aircraft/emergency communication devices or other critical systems whose failure to perform be reasonably expected to result in significant injury or loss of life or catastrophic property damage. Accordingly, Supermicro disclaims any and all liability, and should buyer use or sell such products for use in such ultra-hazardous applications, it does so entirely at its own risk. Furthermore, buyer agrees to fully indemnify, defend and hold Supermicro harmless for and against any and all claims, demands, actions, litigation, and proceedings of any kind arising out of or related to such ultra-hazardous use or sale.