

SUPERO®

SUPERSERVER

5017R-MF

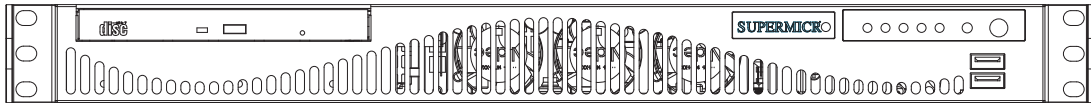

USER'S MANUAL

1.0

The information in this User's Manual has been carefully reviewed and is believed to be accurate. The vendor assumes no responsibility for any inaccuracies that may be contained in this document, makes no commitment to update or to keep current the information in this manual, or to notify any person or organization of the updates. **Please Note: For the most up-to-date version of this manual, please see our web site at www.supermicro.com.**

Super Micro Computer, Inc. ("Supermicro") reserves the right to make changes to the product described in this manual at any time and without notice. This product, including software and documentation, is the property of Supermicro and/or its licensors, and is supplied only under a license. Any use or reproduction of this product is not allowed, except as expressly permitted by the terms of said license.

IN NO EVENT WILL SUPERMICRO BE LIABLE FOR DIRECT, INDIRECT, SPECIAL, INCIDENTAL, SPECULATIVE OR CONSEQUENTIAL DAMAGES ARISING FROM THE USE OR INABILITY TO USE THIS PRODUCT OR DOCUMENTATION, EVEN IF ADVISED OF THE POSSIBILITY OF SUCH DAMAGES. IN PARTICULAR, SUPERMICRO SHALL NOT HAVE LIABILITY FOR ANY HARDWARE, SOFTWARE, OR DATA STORED OR USED WITH THE PRODUCT, INCLUDING THE COSTS OF REPAIRING, REPLACING, INTEGRATING, INSTALLING OR RECOVERING SUCH HARDWARE, SOFTWARE, OR DATA.

Any disputes arising between manufacturer and customer shall be governed by the laws of Santa Clara County in the State of California, USA. The State of California, County of Santa Clara shall be the exclusive venue for the resolution of any such disputes. Super Micro's total liability for all claims will not exceed the price paid for the hardware product.

FCC Statement: This equipment has been tested and found to comply with the limits for a Class A digital device pursuant to Part 15 of the FCC Rules. These limits are designed to provide reasonable protection against harmful interference when the equipment is operated in a commercial environment. This equipment generates, uses, and can radiate radio frequency energy and, if not installed and used in accordance with the manufacturer's instruction manual, may cause harmful interference with radio communications. Operation of this equipment in a residential area is likely to cause harmful interference, in which case you will be required to correct the interference at your own expense.

California Best Management Practices Regulations for Perchlorate Materials: This Perchlorate warning applies only to products containing CR (Manganese Dioxide) Lithium coin cells. "Perchlorate Material-special handling may apply. See www.dtsc.ca.gov/hazardouswaste/perchlorate"

WARNING: Handling of lead solder materials used in this product may expose you to lead, a chemical known to the State of California to cause birth defects and other reproductive harm.

Manual Revision 1.0
Release Date: February 15, 2012

Unless you request and receive written permission from Super Micro Computer, Inc., you may not copy any part of this document.

Information in this document is subject to change without notice. Other products and companies referred to herein are trademarks or registered trademarks of their respective companies or mark holders.

Copyright © 2012 by Super Micro Computer, Inc.
All rights reserved.

Printed in the United States of America

Preface

About This Manual

This manual is written for professional system integrators and PC technicians. It provides information for the installation and use of the SuperServer 5017R-MF. Installation and maintenance should be performed by experienced technicians only.

The SuperServer 5017R-MF is a high-end server based on the SC512F-350B 1U rackmount chassis and the Super X9SRi-F single processor serverboard.

Manual Organization

Chapter 1: Introduction

The first chapter provides a checklist of the main components included with the server system and describes the main features of the X9SRi-F serverboard and the SC512F-350B chassis.

Chapter 2: Server Installation

This chapter describes the steps necessary to install the SuperServer 5017R-MF into a rack and check out the server configuration prior to powering up the system. If your server was ordered without processor and memory components, this chapter will refer you to the appropriate sections of the manual for their installation.

Chapter 3: System Interface

Refer here for details on the system interface, which includes the functions and information provided by the control panel on the chassis as well as other LEDs located throughout the system.

Chapter 4: System Safety

You should thoroughly familiarize yourself with this chapter for a general overview of safety precautions that should be followed when installing and servicing the SuperServer 5017R-MF.

Chapter 5: Advanced Serverboard Setup

Chapter 5 provides detailed information on the X9SRi-F serverboard, including the locations and functions of connections, headers and jumpers. Refer to this chapter when adding or removing processors or main memory and when reconfiguring the serverboard.

Chapter 6: Advanced Chassis Setup

Refer to Chapter 6 for detailed information on the SC512F-350B server chassis. You should follow the procedures given in this chapter when installing, removing or reconfiguring SATA or peripheral drives and when replacing system power supply modules and cooling fans.

Chapter 7: BIOS

The BIOS chapter includes an introduction to BIOS and provides detailed information on running the CMOS Setup Utility.

Appendix A: POST Error Beep Codes

Appendix B: UEFI BIOS Recovery Instructions

Appendix C: System Specifications

Notes

Table of Contents

Chapter 1 Introduction

1-1	Overview	1-1
1-2	Motherboard Features.....	1-2
	Processors	1-2
	Memory	1-2
	Serial ATA.....	1-2
	SCU SATA	1-2
	I/O Ports.....	1-2
	Intel® Intelligent Power Node Manager (NM).....	1-2
1-3	Server Chassis Features	1-3
	Serial ATA Subsystem.....	1-3
	Control Panel	1-3
	Cooling System.....	1-3
1-4	Contacting Supermicro.....	1-5

Chapter 2 Server Installation

2-1	Overview	2-1
2-2	Unpacking the System.....	2-1
2-3	Preparing for Setup.....	2-1
	Choosing a Setup Location.....	2-2
	Rack Precautions	2-2
	Server Precautions.....	2-2
	Rack Mounting Considerations	2-3
	Ambient Operating Temperature	2-3
	Reduced Airflow	2-3
	Mechanical Loading	2-3
	Circuit Overloading.....	2-3
	Reliable Ground	2-3
2-4	Installing the System into a Rack	2-4
	Basic Installation Procedure	2-4
	Installing with Rackmount Kit.....	2-5
2-5	Checking the Serverboard Setup.....	2-9
2-6	Checking the Drive Bay Setup.....	

Chapter 3 System Interface

3-1	Overview	3-1
3-2	Control Panel Buttons.....	3-1

	Reset	3-1
	Power	3-1
3-3	Control Panel LEDs	3-2
	Overheat/Fan Fail	3-2
	NIC2	3-2
	NIC1	3-2
	HDD.....	3-3
	Power	3-3
Chapter 4 System Safety		
4-1	Electrical Safety Precautions	4-1
4-2	General Safety Precautions	4-2
4-3	ESD Precautions	4-3
4-4	Operating Precautions	4-4
Chapter 5 Advanced Motherboard Setup		
5-1	Handling the Motherboard	5-1
	Precautions	5-1
	Unpacking	5-1
5-2	Processor and Heatsink Installation.....	5-2
	Installing an LGA 2011 Processor.....	5-2
	Installing a Passive CPU Heatsink	5-5
	Removing the Heatsink.....	5-5
5-3	Connecting Cables.....	5-7
	Connecting Data Cables	5-7
	Connecting Power Cables	5-7
	Connecting the Control Panel.....	5-7
5-4	I/O Ports	5-8
5-5	Installing Memory	5-9
	Memory Population Guidelines	5-10
5-6	Adding PCI Cards	5-12
5-7	Motherboard Details.....	5-13
	X9SRi-F Quick Reference.....	5-13
5-8	Connector Definitions	5-15
5-9	Jumper Settings	5-22
5-10	Onboard Indicators.....	5-24
5-11	SATA Drive Connections	5-25
5-12	Installing Drivers.....	5-26
	SuperDoctor III	5-27

Chapter 6 Advanced Chassis Setup

6-1	Static-Sensitive Devices.....	6-1
	Precautions	6-1
6-2	Control Panel	6-2
6-3	System Fans	6-3
	System Fan Failure.....	6-3
6-4	Drive Bay Installation/Removal.....	6-4
	Accessing the Drive Bays	6-4
	DVD-ROM Drive Installation	6-5
6-5	Power Supply	6-7
	Power Supply Failure.....	6-7

Chapter 7 BIOS

7-1	Introduction.....	7-1
	Starting BIOS Setup Utility.....	7-1
	How To Change the Configuration Data	7-1
	How to Start the Setup Utility	7-2
7-2	Main Setup.....	7-2
7-3	Advanced Setup Configurations.....	7-4
7-4	Event Logs	7-19
7-5	IPMI.....	7-20
7-6	ISCSI.....	7-22
7-7	Boot Settings	7-23
7-8	Security Settings	7-24
7-9	Exit Options.....	7-25
7-10	Main Configuration Page	7-26

Appendix A POST Error Beep Codes

Appendix B UEFI BIOS Recovery Instructions

Appendix C System Specifications

Chapter 1

Introduction

1-1 Overview

The SuperServer 5017R-MF is a high-end server comprised of two main sub-systems: the SC512F-350B 1U server chassis and the X9SRi-F single processor motherboard. Please refer to our web site for information on operating systems that have been certified for use with the system (www.supermicro.com).

In addition to the motherboard and chassis, various hardware components have been included with the 5017R-MF, as listed below:

- Two sets of 4-cm counter-rotating fans (FAN-0087L4)
- One passive CPU heatsink (SNK-P0047P)
- One air shroud for 1U system (MCP-310-19007-0N)
- One riser card for one PCI-E 3.0 x16 PCI add-on card (RSC-RR1U-E16)
- One rackmount kit (MCP-290-00050-0N)
- One CD containing drivers and utilities
- SuperServer 5017R-MF User's Manual

1-2 Motherboard Features

At the heart of the SuperServer 5017R-MF lies the X9SRi-F, a single processor motherboard based on Intel's C600 chipset. Below are the main features of the X9SRi-F (see Figure 1-1 for a block diagram of the chipset).

Processors

The X9SRi-F supports a single Intel® Xeon® E5-2600/E5-1600 Series processor in an LGA 2011 socket. Please refer to the motherboard description pages on our web site for a complete listing of supported processors.

Memory

The X9SRi-F has eight DIMM sockets that can support up to 256 GB of DDR3-1600/1333/1066 ECC R/LRDIMMs (LRDIMM = Reduced Load DIMMs) or up to 64GB of ECC UDIMMs. Please refer to Chapter 5 for installing memory.

Serial ATA

An on-chip SATA controller is integrated into the X9SRi-F to provide two 6 Gb/sec SATA3 ports and four 3 Gb/sec SATA2 ports. The 5017R-MF supports a single (internal) SATA hard drive.

SCU SATA

An additional SCU SATA controller integrated into the chipset provides four SATA 2 ports. RAID 0, 1 and 10 are supported. The SATA drives are hot-swappable units.

Note: You must have RAID set up to enable the hot-swap capability of the SATA drives. Documentation on RAID setup guidelines can be found on our web site.

I/O Ports

The color-coded I/O ports include one COM port, a VGA (monitor) port, two USB 2.0 ports, PS/2 mouse and keyboard ports and two gigabit Ethernet ports. A dedicated IPMI LAN port is also included.

Intel® Intelligent Power Node Manager (NM)

The Intel® Intelligent Power Node Manager (IPNM) provides your system with real-time thermal control and power management for maximum energy efficiency. Although IPNM Specification Version 1.5 is supported by the BMC (Baseboard Management Controller), your system must also have IPNM-compatible Manageability Engine (ME) firmware installed to use this feature.

1-3 Server Chassis Features

The SC512F-350B is a short depth (14.5") 1U rackmount server chassis. The following is a general outline of the main features of the SC512F-350B chassis.

System Power

When configured as the SuperServer 5017R-MF, the SC512F-350B chassis features a single power supply.

Serial ATA Subsystem

The SC512F-350B chassis is designed to support one internal SATA hard drive. The internal drive is not hot-swappable.

Control Panel

The SC512F-350B's control panel provides important system monitoring and control information. LEDs indicate power on, network activity, hard disk drive activity, overheat warning and fan failure. The control panel also includes a main power button and a reset button.

Cooling System

The SC512F-350B chassis has an innovative cooling design that features an air shroud and two 4-cm counter-rotating fans with user-defined fan speed control. (Fan speed may be defined with a BIOS setting.)

**Figure 1-1. Intel C600 Chipset:
System Block Diagram**

Note: This is a general block diagram. Please see Chapter 5 for details.

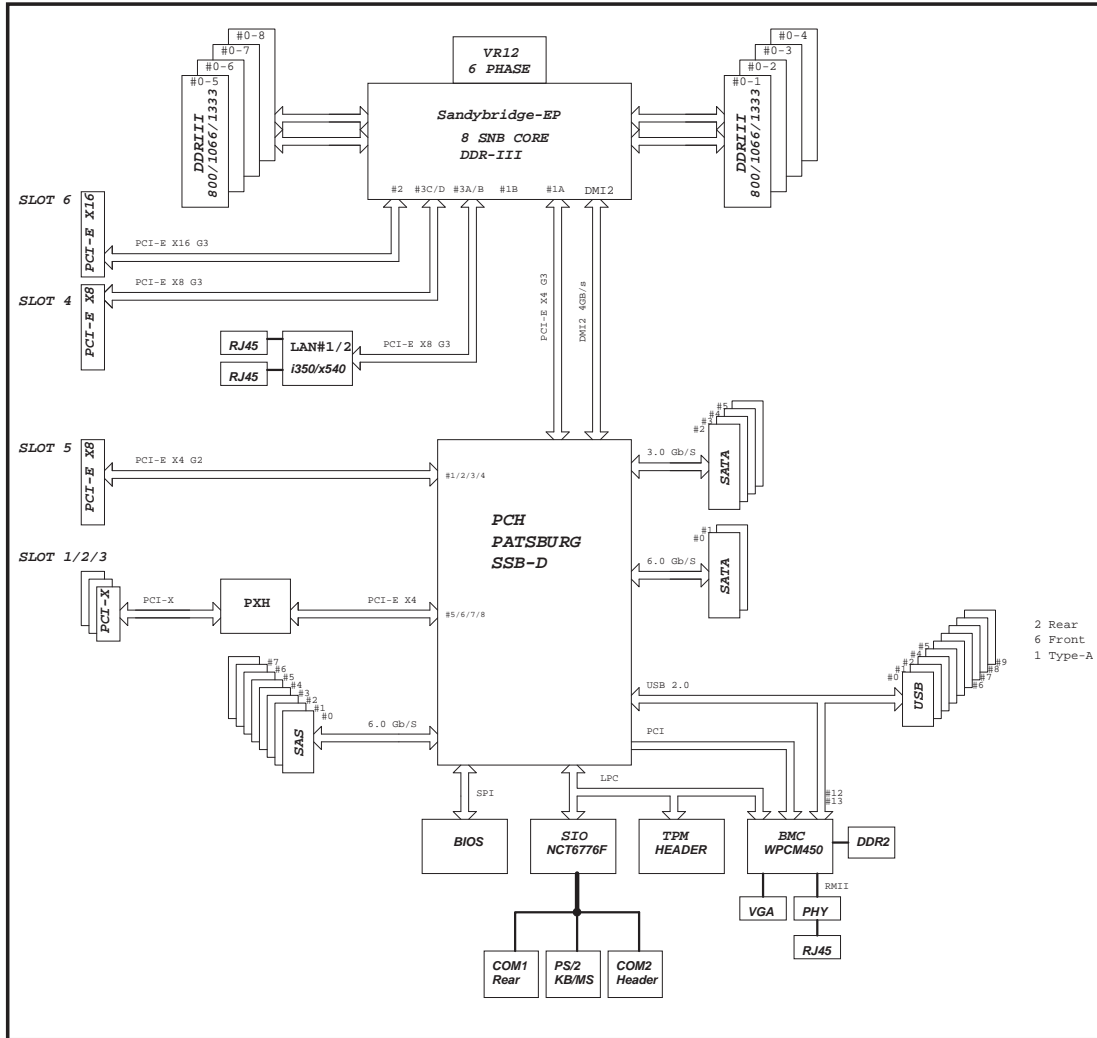

1-4 Contacting Supermicro

Headquarters

Address: Super Micro Computer, Inc.
980 Rock Ave.
San Jose, CA 95131 U.S.A.

Tel: +1 (408) 503-8000

Fax: +1 (408) 503-8008

Email: marketing@supermicro.com (General Information)
support@supermicro.com (Technical Support)

Web Site: www.supermicro.com

Europe

Address: Super Micro Computer B.V.
Het Sterrenbeeld 28, 5215 ML
's-Hertogenbosch, The Netherlands

Tel: +31 (0) 73-6400390

Fax: +31 (0) 73-6416525

Email: sales@supermicro.nl (General Information)
support@supermicro.nl (Technical Support)
rma@supermicro.nl (Customer Support)

Asia-Pacific

Address: Super Micro Computer, Inc.
4F, No. 232-1, Liancheng Rd.
Chung-Ho 235, Taipei County
Taiwan, R.O.C.

Tel: +886-(2) 8226-3990

Fax: +886-(2) 8226-3991

Web Site: www.supermicro.com.tw

Technical Support:

Email: support@supermicro.com.tw

Tel: 886-2-8226-5990

Notes

Chapter 2

Server Installation

2-1 Overview

This chapter provides a quick setup checklist to get your SuperServer 5017R-MF up and running. Following the steps in the order given should enable you to have the system operational within a minimal amount of time. This quick setup assumes that your system has come to you with the processor and memory preinstalled. If your system is not already fully integrated with a serverboard, processor, system memory etc., please turn to the chapter or section noted in each step for details on installing specific components.

2-2 Unpacking the System

You should inspect the box the server was shipped in and note if it was damaged in any way. If the server itself shows damage, you should file a damage claim with the carrier who delivered it.

Decide on a suitable location for the rack unit that will hold the server. It should be situated in a clean, dust-free area that is well ventilated. Avoid areas where heat, electrical noise and electromagnetic fields are generated. You will also need it placed near a grounded power outlet. Read the Rack and Server Precautions in the next section.

2-3 Preparing for Setup

The SuperServer 5017R-MF does not ship with a rack rail hardware package as the system can be rack mounted without the use of rails. An optional rack rail package is available if you wish to order from Supermicro. Follow the steps in the order given to complete the installation process in a minimal amount of time. Please read this section in its entirety before you begin the installation procedure outlined in the sections that follow.

Choosing a Setup Location

- Leave enough clearance in front of the rack to enable you to open the front door completely (~25 inches) and approximately 30 inches of clearance in the back of the rack to allow for sufficient airflow and ease in servicing. This product is for installation only in a Restricted Access Location (dedicated equipment rooms, service closets and the like).
- This product is not suitable for use with visual display work place devices according to §2 of the the German Ordinance for Work with Visual Display Units.



Warnings and Precautions!



Rack Precautions

- Ensure that the leveling jacks on the bottom of the rack are fully extended to the floor with the full weight of the rack resting on them.
- In single rack installation, stabilizers should be attached to the rack. In multiple rack installations, the racks should be coupled together.
- Always make sure the rack is stable before extending a component from the rack.
- You should extend only one component at a time - extending two or more simultaneously may cause the rack to become unstable.

Server Precautions

- Review the electrical and general safety precautions in Chapter 4.
- Determine the placement of each component in the rack *before* you install the rails.
- Install the heaviest server components on the bottom of the rack first, and then work up.
- Use a regulating uninterruptible power supply (UPS) to protect the server from power surges, voltage spikes and to keep your system operating in case of a power failure.

- Allow the hot plug SATA drives and power supply modules to cool before touching them.
- Always keep the rack's front door and all panels and components on the servers closed when not servicing to maintain proper cooling.

Rack Mounting Considerations

Ambient Operating Temperature

If installed in a closed or multi-unit rack assembly, the ambient operating temperature of the rack environment may be greater than the ambient temperature of the room. Therefore, consideration should be given to installing the equipment in an environment compatible with the manufacturer's maximum rated ambient temperature (T_{mra}).

Reduced Airflow

Equipment should be mounted into a rack so that the amount of airflow required for safe operation is not compromised.

Mechanical Loading

Equipment should be mounted into a rack so that a hazardous condition does not arise due to uneven mechanical loading.

Circuit Overloading

Consideration should be given to the connection of the equipment to the power supply circuitry and the effect that any possible overloading of circuits might have on overcurrent protection and power supply wiring. Appropriate consideration of equipment nameplate ratings should be used when addressing this concern.

Reliable Ground

A reliable ground must be maintained at all times. To ensure this, the rack itself should be grounded. Particular attention should be given to power supply connections other than the direct connections to the branch circuit (i.e. the use of power strips, etc.).

2-4 Installing the System into a Rack

This section provides information on installing the SuperServer 5017R-MF into a rack.

Note: the server may be installed as is - rack hardware is optional.

Basic Installation Procedure

The 5017R-MF server comes with two rack mounting brackets, which are located on each side at the front of the chassis. To mount the system into a rack, simply screw these brackets directly to the front of the rack (two screws for each bracket). As Figure 2-1 shows, the brackets can be located at the front of the chassis (left figure) or moved approximately one-third to the rear of the chassis (right figure).

Figure 2-1. Identifying the Sections of the Rack Rails

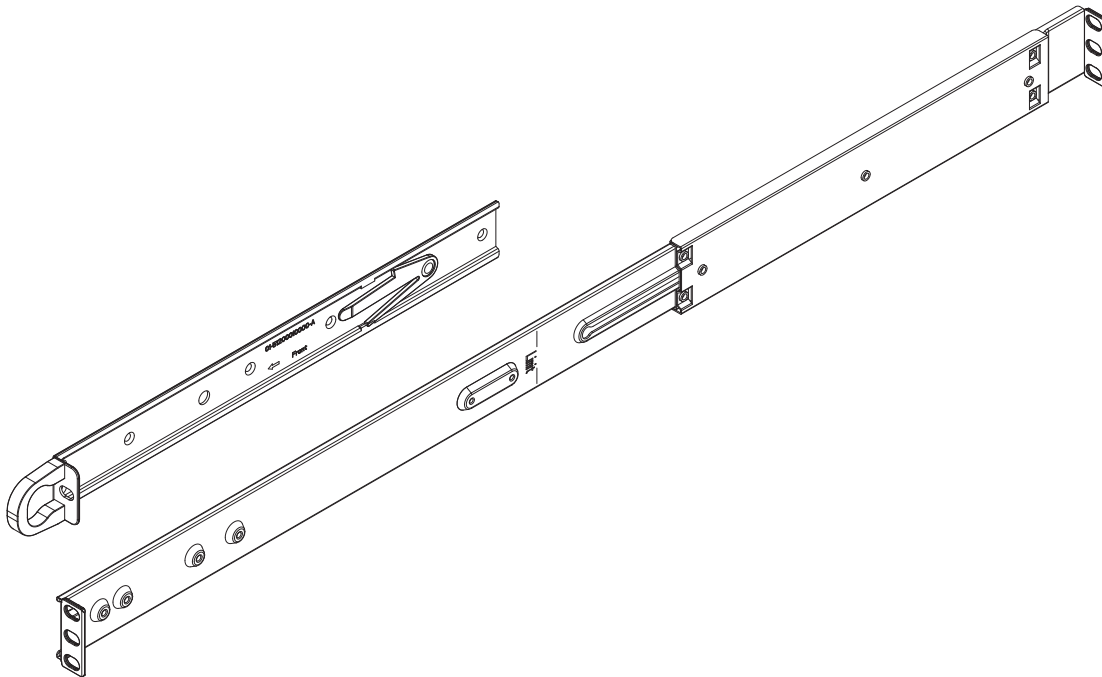

Installing with Rackmount Kit

This is a guideline for installing the unit into a rack with the optional rack kit (MCP-290-00004-03). You should also refer to the installation instructions that came with the rack unit you are using. Be aware that there are a variety of rack units on the market, which may mean the assembly procedure will differ slightly.

The rack hardware includes two assemblies that consists of two sections: an inner rail that secures to the chassis and an outer rail that secures directly to the rack itself (see Figure 2-1).

Installing the Chassis Rails

1. Detach the two rail sections from each other by depressing the locking tab on the inner rail to release it from its locked position, then pull the two rails completely apart.
2. Repeat step 1 for the remaining rail assembly.
3. Position the fixed chassis rail sections you just removed along the side of the chassis making sure the three screw holes line up. Note that the rails are left/right side specific.
4. Screw the rail securely to the side of the chassis (see Figure 2-2). Repeat this procedure for the other rail on the other side of the chassis. You will also need to attach the rail brackets when installing into a telco rack.

Locking Tabs: Both chassis rails have a locking tab, which serves two functions. The first is to lock the server into place when installed and pushed fully into the rack, which is its normal position. Secondly, these tabs also lock the server in place when fully extended from the rack. This prevents the server from coming completely out of the rack when you pull it out for servicing.

Figure 2-2. Installing Chassis Rails

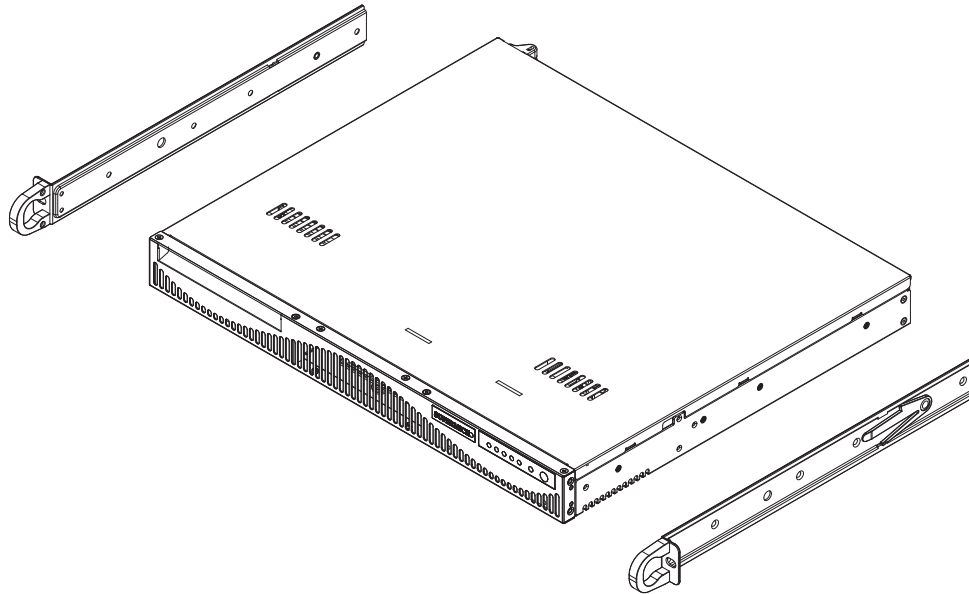

Installing the Rack Rails

1. Determine where you want to place the 5017R-MF in the rack (see Rack and Server Precautions in Section 2-3).
2. Position the fixed rack rail/sliding rail guide assemblies at the desired location in the rack, keeping the sliding rail guide facing the inside of the rack.
3. Screw the assembly securely to the rack using the brackets provided.
4. Attach the other assembly to the other side of the rack, making sure that both are at the exact same height and with the rail guides facing inward.

Installing the Server into the Rack

You should now have rails attached to both the chassis and the rack unit. The next step is to install the server into the rack.

1. Line up the rear of the chassis rails with the front of the rack rails.
2. Slide the chassis rails into the rack rails, keeping the pressure even on both sides (you may have to depress the locking tabs when inserting). See Figure 2-3.
3. When the server has been pushed completely into the rack, you should hear the locking tabs "click".

**Figure 2-3. Installing the Server into a Rack
(w/ Optional Rackmount Kit)**

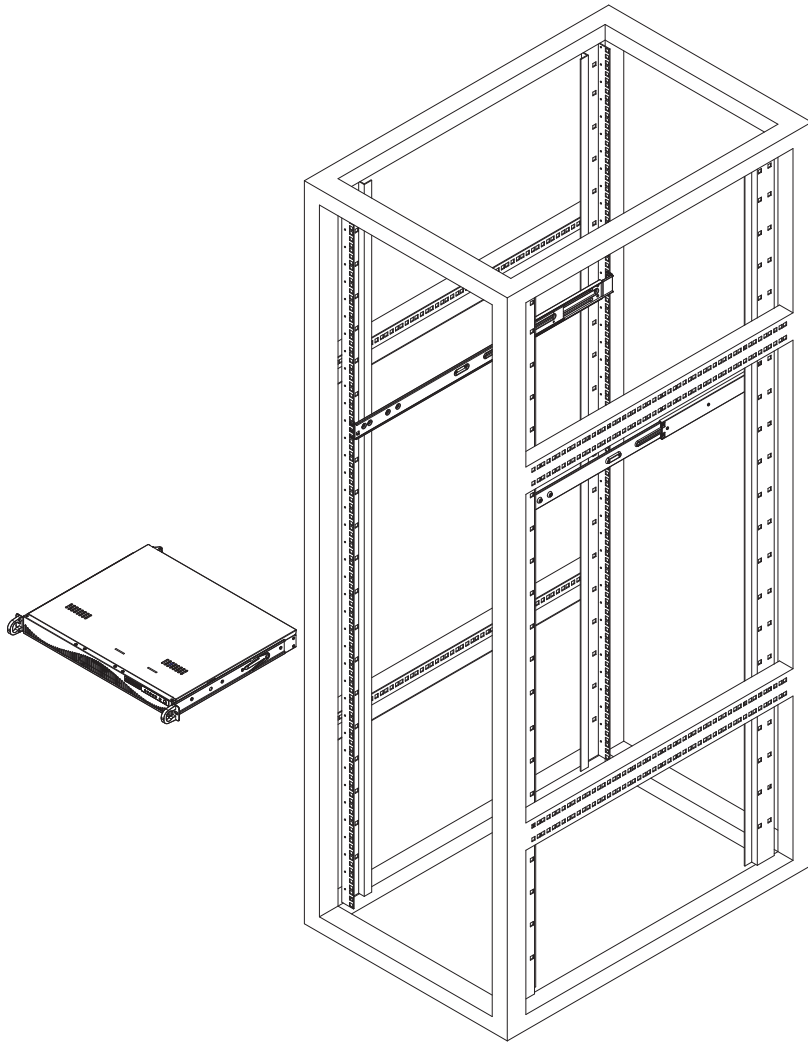

4. Finish by inserting and tightening the thumbscrews that hold the front of the server to the rack.

Installing the Server into a Telco Rack

If you are installing the SuperServer 5017R-MF into a Telco type rack, follow the directions given on the previous pages for rack installation. The only difference in the installation procedure will be the positioning of the rack brackets to the rack. They should be spaced apart just enough to accommodate the width of the telco rack.

Figure 2-4. Installing the Server into a Telco Rack

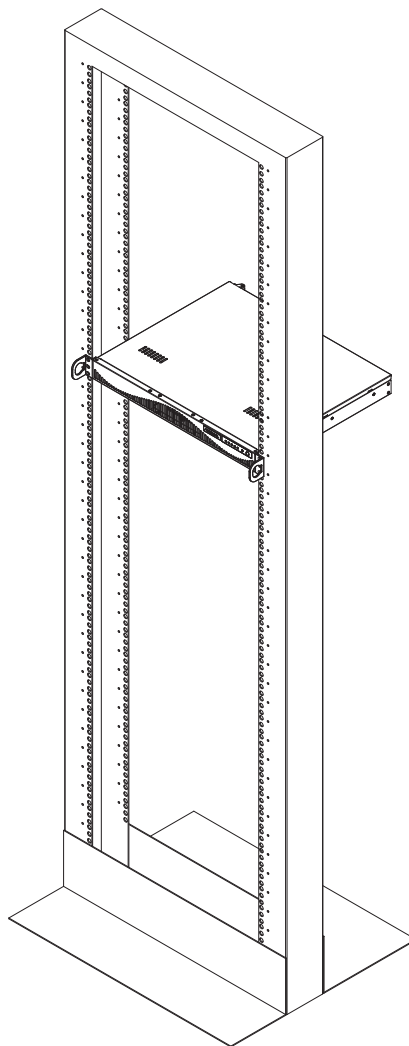

2-5 Checking the Serverboard Setup

After you install the server in the rack, you will need to open the unit to make sure the serverboard is properly installed and all the connections have been made.

Removing the Chassis Cover

1. Release the retention screws that secure the unit to the rack.
2. Grasp the two handles on either side and pull the unit straight out until it locks (you will hear a "click").
3. Remove the screws from the chassis cover (see Figure 2-5).
4. Release the top cover by pushing it away from you until it stops. You can then lift the top cover from the chassis to gain full access to the inside of the server

Checking the Components

1. You may have processors already installed into the serverboard. Each processor should have its own heatsink attached. See Chapter 5 for instructions on processor installation.
2. The 5017R-MF server may have come with system memory already installed. Make sure all DIMMs are fully seated in their slots. For details on adding system memory, refer to Chapter 5.
3. If desired, you can install an add-on card to the system. See Chapter 5 for details on installing a PCI add-on card.
4. Make sure all power and data cables are properly connected and not blocking the airflow. See Chapter 5 for details on cable connections. Also, check that the air shroud is properly installed.

Notes

Chapter 3

System Interface

3-1 Overview

There are several LEDs on the control panel to keep you constantly informed of the overall status of the system as well as the activity and health of specific components. There are also two buttons on the chassis control panel. This chapter explains the meanings of all LED indicators and the appropriate response you may need to take.

3-2 Control Panel Buttons

There are two push buttons located on the front of the chassis: a reset button and a power on/off button.



Reset

The reset switch reboots the system.

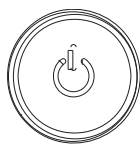

Power

This is the main power switch, which is used to apply or turn off the main system power. Turning off system power with this button removes the main power but keeps standby power supplied to the system.

3-3 Control Panel LEDs

The control panel located on the front of the SC512F-520B chassis has five LEDs. These LEDs provide you with critical information related to different parts of the system. This section explains what each LED indicates when illuminated and any corrective action you may need to take.



Overheat/Fan Fail

When this LED flashes it indicates a fan failure. When on continuously (on and not flashing) it indicates an overheat condition, which may be caused by cables obstructing the airflow in the system or the ambient room temperature being too warm. Check the routing of the cables and make sure all fans are present and operating normally. You should also check to make sure that the chassis covers are installed. Finally, verify that the heatsinks are installed properly (see Chapter 5). This LED will remain flashing or on as long as the overheat condition exists.



NIC2

Indicates network activity on LAN2 when flashing.



NIC1

Indicates network activity on LAN1 when flashing.



HDD

Channel activity for HDDs. This light indicates IDE drive activity when flashing.



Power

Indicates power is being supplied to the system's power supply units. This LED should normally be illuminated when the system is operating.

Notes

Chapter 4

System Safety

4-1 Electrical Safety Precautions



Basic electrical safety precautions should be followed to protect yourself from harm and the SuperServer 5017R-MF from damage:

- Be aware of the locations of the power on/off switch on the chassis as well as the room's emergency power-off switch, disconnection switch or electrical outlet. If an electrical accident occurs, you can then quickly remove power from the system.
- Do not work alone when working with high voltage components.
- Power should always be disconnected from the system when removing or installing main system components, such as the serverboard, memory modules and floppy drive. When disconnecting power, you should first power down the system with the operating system first and then unplug the power cords of all the power supply units in the system.
- When working around exposed electrical circuits, another person who is familiar with the power-off controls should be nearby to switch off the power if necessary.
- Use only one hand when working with powered-on electrical equipment. This is to avoid making a complete circuit, which will cause electrical shock. Use extreme caution when using metal tools, which can easily damage any electrical components or circuit boards they come into contact with.
- Do not use mats designed to decrease static electrical discharge as protection from electrical shock. Instead, use rubber mats that have been specifically designed as electrical insulators.
- The power supply power cords must include a grounding plug and must be plugged into grounded electrical outlets.

- This product may be connected to an IT power system. In all cases, make sure that the unit is also reliably connected to Earth (ground).
- Serverboard Battery: **CAUTION** - There is a danger of explosion if the onboard battery is installed upside down, which will reverse its polarities (see Figure 4-1). This battery must be replaced only with the same or an equivalent type recommended by the manufacturer (CR2032). Dispose of used batteries according to the manufacturer's instructions.
- DVD-ROM Laser: **CAUTION** - this server may have come equipped with a DVD-ROM drive. To prevent direct exposure to the laser beam and hazardous radiation exposure, do not open the enclosure or use the unit in any unconventional way.
- Mainboard replaceable soldered-in fuses: Self-resetting PTC (Positive Temperature Coefficient) fuses on the mainboard must be replaced by trained service technicians only. The new fuse must be the same or equivalent as the one replaced. Contact technical support for details and support.

4-2 General Safety Precautions



Follow these rules to ensure general safety:

- Keep the area around the 5017R-MF clean and free of clutter.
- The 5017R-MF weighs approximately 18 lbs (8.2 kg). When lifting the system, two people at either end should lift slowly with their feet spread out to distribute the weight. Always keep your back straight and lift with your legs.
- Place the chassis top cover and any system components that have been removed away from the system or on a table so that they won't accidentally be stepped on.
- While working on the system, do not wear loose clothing such as neckties and unbuttoned shirt sleeves, which can come into contact with electrical circuits or be pulled into a cooling fan.

- Remove any jewelry or metal objects from your body, which are excellent metal conductors that can create short circuits and harm you if they come into contact with printed circuit boards or areas where power is present.
- After accessing the inside of the system, close the system back up and secure it to the rack unit with the retention screws after ensuring that all connections have been made.

4-3 ESD Precautions



Electrostatic Discharge (ESD) is generated by two objects with different electrical charges coming into contact with each other. An electrical discharge is created to neutralize this difference, which can damage electronic components and printed circuit boards. The following measures are generally sufficient to neutralize this difference before contact is made to protect your equipment from ESD:

- Use a grounded wrist strap designed to prevent static discharge.
- Keep all components and printed circuit boards (PCBs) in their antistatic bags until ready for use.
- Touch a grounded metal object before removing the board from the antistatic bag.
- Do not let components or PCBs come into contact with your clothing, which may retain a charge even if you are wearing a wrist strap.
- Handle a board by its edges only; do not touch its components, peripheral chips, memory modules or contacts.
- When handling chips or modules, avoid touching their pins.
- Put the serverboard and peripherals back into their antistatic bags when not in use.
- For grounding purposes, make sure your computer chassis provides excellent conductivity between the power supply, the case, the mounting fasteners and the serverboard.

4-4 Operating Precautions



Care must be taken to assure that the chassis cover is in place when the 5017R-MF is operating to assure proper cooling. Out of warranty damage to the system can occur if this practice is not strictly followed.

Figure 4-1. Installing the Onboard Battery

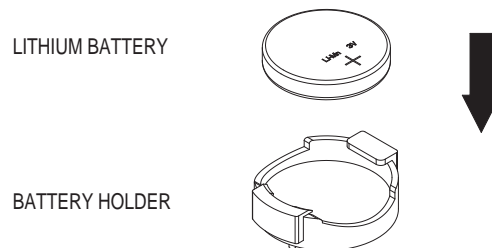

Please handle used batteries carefully. Do not damage the battery in any way; a damaged battery may release hazardous materials into the environment. Do not discard a used battery in the garbage or a public landfill. Please comply with the regulations set up by your local hazardous waste management agency to dispose of your used battery properly.

Chapter 5

Advanced Motherboard Setup

This chapter covers the steps required to install processors and heatsinks to the X9SRi-F motherboard, connect the data and power cables and install add-on cards. All motherboard jumpers and connections are described and a layout and quick reference chart are included in this chapter. Remember to close the chassis completely when you have finished working on the motherboard to protect and cool the system sufficiently.

5-1 Handling the Motherboard

Static electrical discharge can damage electronic components. To prevent damage to printed circuit boards, it is important to handle them very carefully (see Chapter 4). Also note that the size and weight of the motherboard can cause it to bend if handled improperly, which may result in damage. To prevent the motherboard from bending, keep one hand under the center of the board to support it when handling.

The following measures are generally sufficient to protect your equipment from static discharge.

Precautions

- Use a grounded wrist strap designed to prevent static discharge.
- Touch a grounded metal object before removing any board from its antistatic bag.
- Handle a board by its edges only; do not touch its components, peripheral chips, memory modules or gold contacts.
- When handling chips or modules, avoid touching their pins.
- Put the motherboard, add-on cards and peripherals back into their antistatic bags when not in use.

Unpacking

The motherboard is shipped in antistatic packaging to avoid static damage. When unpacking the board, make sure the person handling it is static protected.

5-2 Processor and Heatsink Installation

Notes:

- Always connect the power cord last and always remove it before adding, removing or changing any hardware components. Make sure that you install the processor into the CPU socket before you install the CPU heatsink.
- If you buy a CPU separately, make sure that you use an Intel-certified multi-directional heatsink only.
- Make sure to install the motherboard into the chassis before you install the CPU heatsinks.
- When receiving a motherboard without a processor pre-installed, make sure that the plastic CPU socket cap is in place and none of the socket pins are bent; otherwise, contact your retailer immediately.
- Refer to the Supermicro web site for updates on CPU support.

Installing an LGA 2011 Processor

1. There are two levers on the LGA 2011 socket. First press and release the load lever labeled 'Open 1st'.
2. Press the second load lever labeled 'Close 1st' to release the load plate from its locked position.

Press down on the lever labeled 'Close 1st'

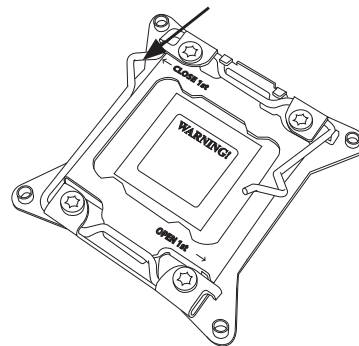

Pull lever away from the socket

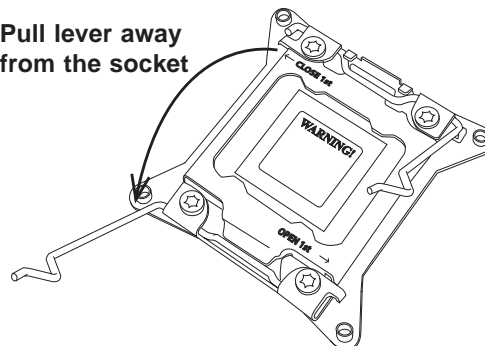

3. With the lever labeled 'Close 1st' fully retracted, gently push down on the 'Open 1st' lever to open the load plate. Lift the load plate to open it completely.
4. Using your thumb and the index finger, remove the 'WARNING' plastic cap from the socket.
5. Use your thumb and index finger to hold the CPU by its edges. Align the CPU keys, which are semi-circle cutouts, against the socket keys.
6. Once they are aligned, carefully lower the CPU straight down into the socket. (Do not drop the CPU on the socket. Do not move the CPU horizontally or vertically and do not rub the CPU against any pins of the socket, which may damage the CPU or the socket.)

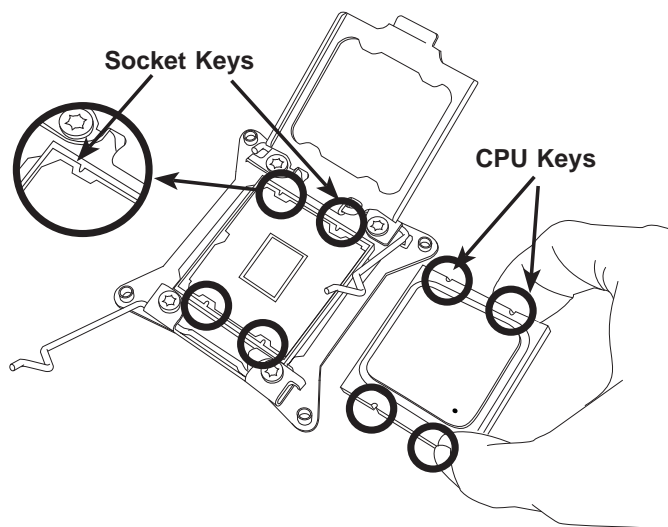
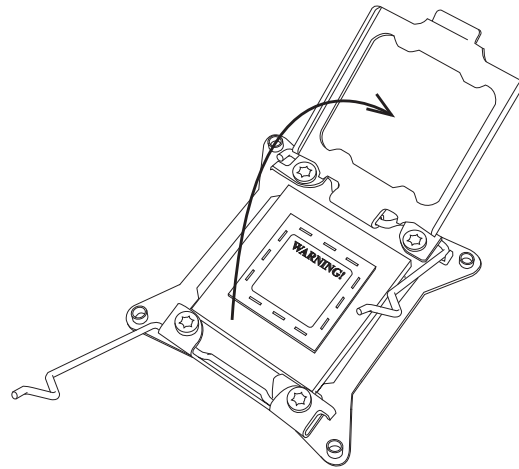
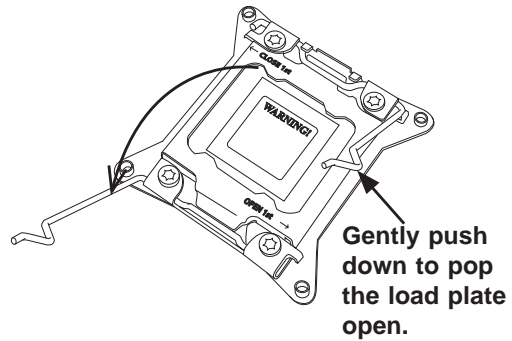



Warning: You can only install the CPU to the socket in one direction. Make sure that the CPU is properly inserted into the socket before closing the load plate. If it doesn't close properly, do not force it as it may damage your CPU. Instead, open the load plate again and double-check that the CPU is aligned properly.

7. With the CPU in the socket, inspect the four corners of the CPU to make sure that they are flush with the socket.
8. Close the load plate. Lock the lever labeled 'Close 1st', then lock the lever labeled 'Open 1st'. Use your thumb to gently push the load levers down until the lever locks.

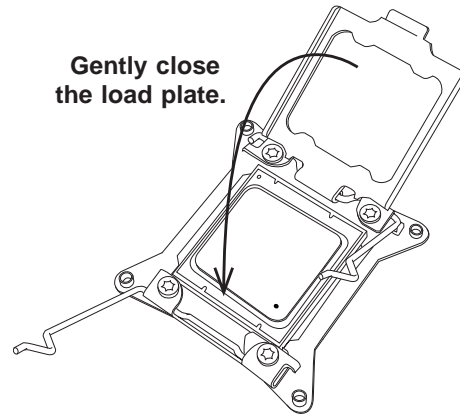

Push down and lock the level labeled 'Close 1st'.

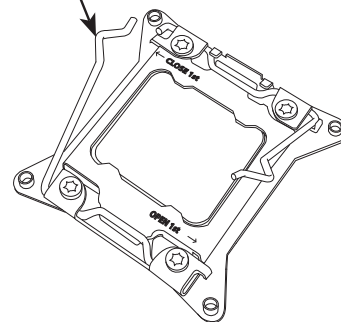

Lever Lock

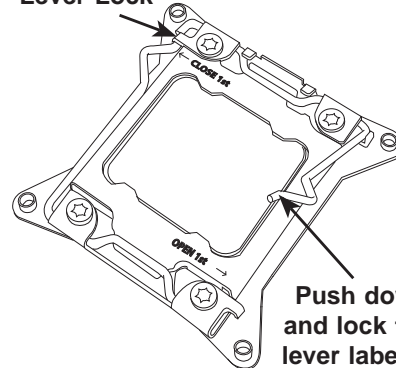

Push down and lock the lever labeled 'Open 1st'.

Installing a Passive CPU Heatsink

1. Do not apply any thermal grease to the heatsink or the CPU die; the required amount has already been applied.
2. Place the heatsink on top of the CPU so that the four mounting holes are aligned with those on the motherboard and the heatsink bracket underneath.
3. Screw in two diagonal screws (i.e., the #1 and the #2 screws) until just snug (do not over-tighten the screws to avoid possible damage to the CPU.)
4. Finish the installation by fully tightening all four screws.

Removing the Heatsink



Warning: We do not recommend removing the CPU or the heatsink. However, if you do need to remove the heatsink, please follow the instructions below to prevent damage to the CPU or other components.

1. Unscrew the heatsink screws from the motherboard in the sequence as shown in the illustration below.
2. Gently wriggle the heatsink to loosen it from the CPU (do not use excessive force).
3. Once the CPU is loose, remove it from the CPU socket.
4. Clean the surface of the CPU and the heatsink, removing the used thermal grease. Reapply the proper amount of thermal grease to the surface before re-installing the heatsink.

Figure 5-1. Installing the Heatsink

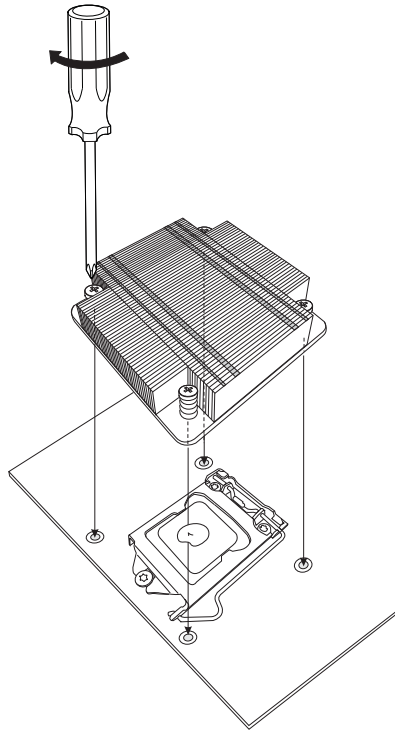
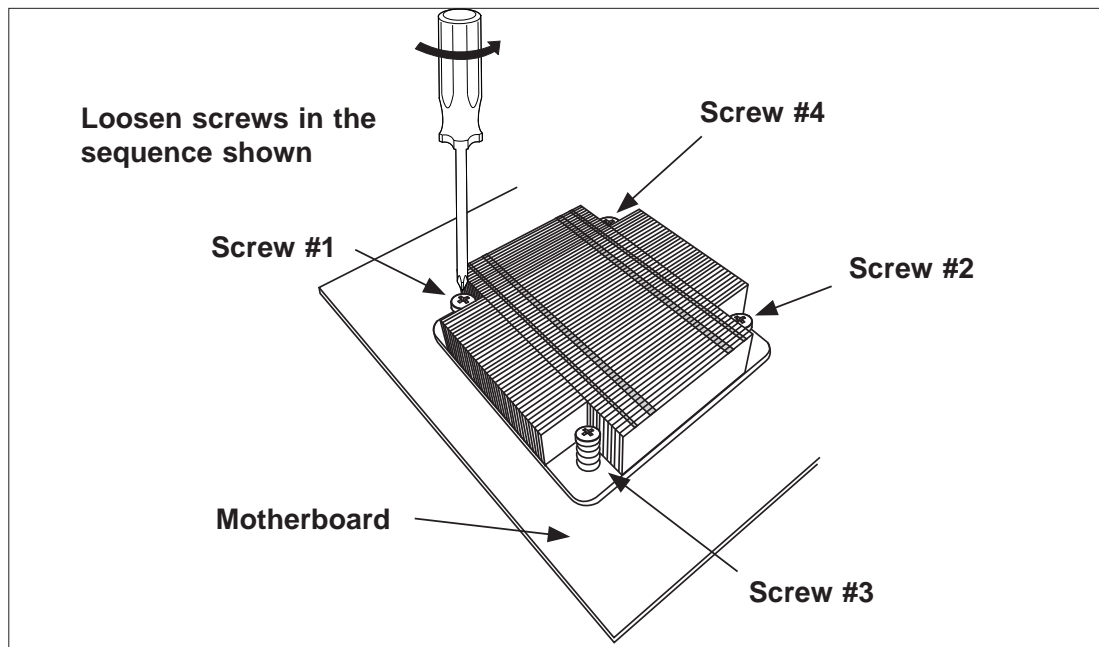

Figure 5-2. Removing the Heatsink



5-3 Connecting Cables

Now that the processors are installed, the next step is to connect the cables to the motherboard. These include the data (ribbon) cables for the peripherals and control panel and the power cables.

Connecting Data Cables

The cables used to transfer data from the peripheral devices have been carefully routed in preconfigured systems to prevent them from blocking the flow of cooling air that moves through the system from front to back. If you need to disconnect any of these cables, you should take care to reroute them as they were originally after reconnecting them (make sure the red wires connect to the pin 1 locations). If you are configuring the system, keep the airflow in mind when routing the cables.

The following data cables (with their motherboard connector locations noted) should be connected.

See the motherboard layout diagram in this chapter for connector locations.

- Control Panel cable (JF1, see next page)
- SATA cable (I-SATA0)

Connecting Power Cables

The X9SRi-F has a 24-pin primary power supply connector designated "JPW1" for connection to the ATX power supply. Connect the appropriate connector from the power supply to JPW1 to supply power to the motherboard. See the Connector Definitions section in this chapter for power connector pin definitions.

In addition, your power supply must be connected to the 8-pin Processor Power connector at JPW2.

Connecting the Control Panel

JF1 contains header pins for various front control panel connectors. See Figure 5-1 for the pin locations of the various front control panel buttons and LED indicators. Please note that even and odd numbered pins are on opposite sides of each header.

All JF1 wires have been bundled into single keyed ribbon cable to simplify their connection. Connect one end of this cable to JF1 and the other end to the Control Panel printed circuit board, located just behind the system status LEDs in the chassis.

See the Connector Definitions section in this chapter for details and pin descriptions of JF1.

Figure 5-1. Front Control Panel Header Pins (JF1)

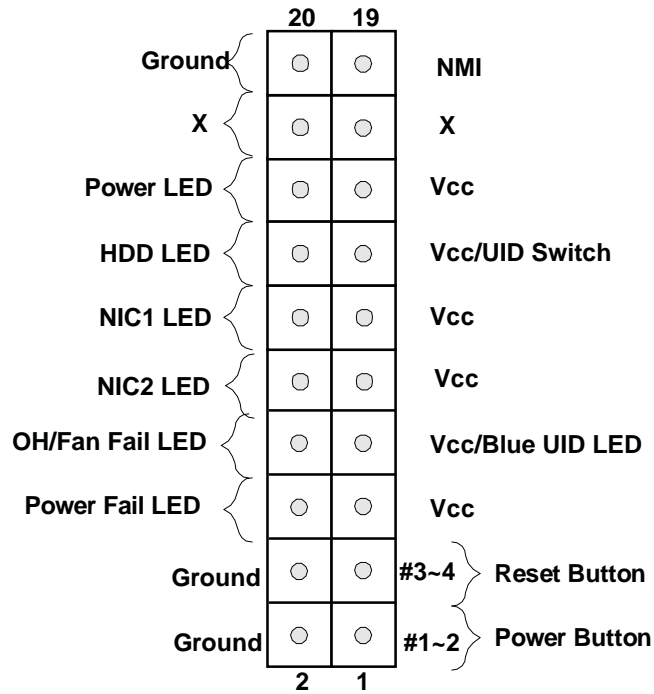

5-4 I/O Ports

The I/O ports are color coded in conformance with the PC 99 specification. See Figure 5-2 below for the colors and locations of the various I/O ports.

Figure 5-2. Rear Panel I/O Ports

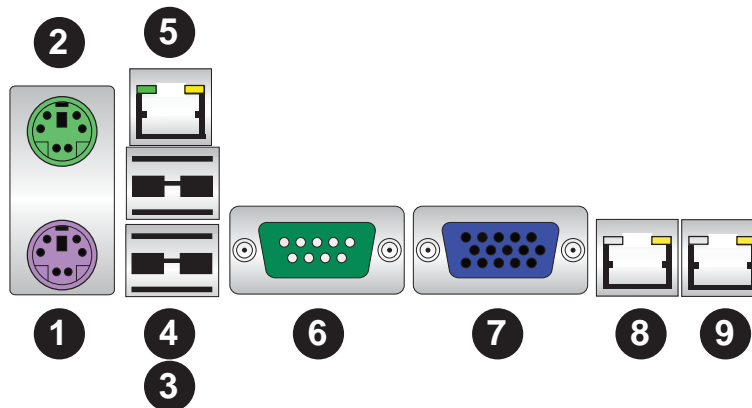

I/O Ports	
1. Keyboard (Purple)	6. COM1
2. PS/2 Mouse (Green)	7. VGA
3. USB Port 0	8. LAN1
4. USB Port 1	9. LAN2
5. IPMI LAN	

5-5 Installing Memory

Note: Check the Supermicro web site for recommended memory modules.

CAUTION

Exercise extreme care when installing or removing DIMM modules to prevent any possible damage.

Installing DIMMs

1. Insert the desired number of DIMMs into the memory slots, starting with slot DIMMA1.
2. Push the release tabs outwards on both ends of the DIMM slot to unlock it.
3. Align the key on the DIMM module with the receptive point on the slot.
4. Use two thumbs together to press on both ends of the module straight down into the slot until the module snaps into place.
5. Press the release tabs to the lock positions to secure the DIMM module into the slot. See Figure 5-3.

Memory Support

The X9SRi-F supports up to 256 GB of DDR3-1600/1333/1066 ECC R/LRDIMMs (LRDIMM = Reduced Load DIMMs) or up to 64GB of ECC UDIMMs. Populating these DIMM modules with a pair of memory modules of the same type and same size will result in interleaved memory, which will improve memory performance.

Figure 5-3. Installing DIMM into Slot

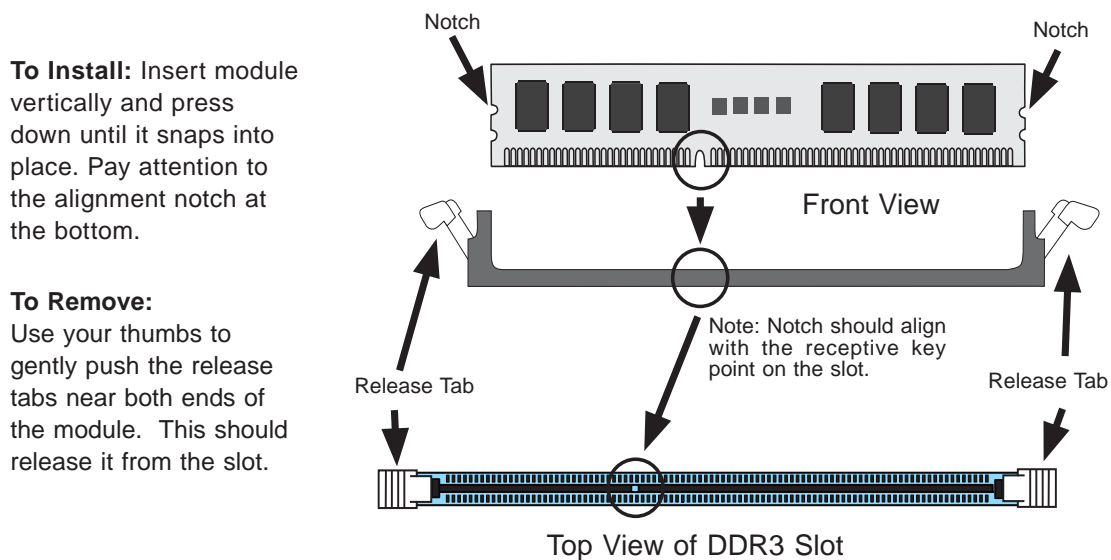

Memory Population Guidelines

DIMM slots should be populated in the following order: DIMMA1, DIMMB1, DIMMC1, DIMMD1 then DIMMA2, DIMMB2, DIMMC2, DIMMD2.

- Always use DDR3 DIMM modules of the same size, type and speed.
- Mixed DIMM speeds can be installed, however, all DIMMs will run at the speed of the slowest DIMM.
- An odd-number of modules is supported (1 ,3 ,5 ,or 7 modules). However, for best memory performance, install DIMM modules in pairs.

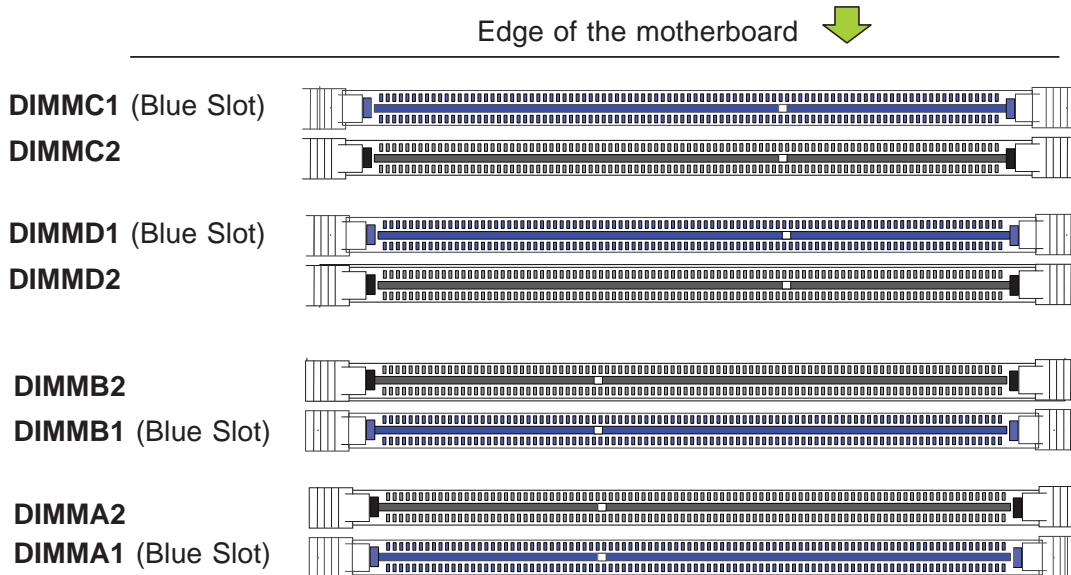

Recommended Population (Balanced)								
DIMMA1	DIMMA2	DIMMB1	DIMMB2	DIMMC1	DIMMC2	DIMMD1	DIMMD2	Total Memory
2GB	2GB							4GB
2GB	2GB	2GB	2GB					8GB
2GB	2GB	2GB	2GB	2GB	2GB			12GB
2GB	2GB	2GB	2GB	2GB	2GB	2GB	2GB	16GB
4GB	4GB							8GB
4GB	4GB	4GB	4GB					16GB
4GB	4GB	4GB	4GB	4GB	4GB			24GB
4GB	4GB	4GB	4GB	4GB	4GB	4GB	4GB	32GB
8GB	8GB							16GB
8GB	8GB	8GB	8GB					32GB
8GB	8GB	8GB	8GB	8GB	8GB			64GB
8GB	8GB	8GB	8GB	8GB	8GB	8GB	8GB	128GB
16GB	16GB							32GB
16GB	16GB	16GB	16GB					64GB
16GB	16GB	16GB	16GB	16GB	16GB			96GB
16GB	16GB	16GB	16GB	16GB	16GB	16GB	16GB	128GB
32GB	32GB							64GB
32GB	32GB	32GB	32GB					128GB
32GB	32GB	32GB	32GB	32GB	32GB			192GB
32GB	32GB	32GB	32GB	32GB	32GB	32GB	32GB	256GB

5-6 Adding PCI Cards

PCI Expansion Slots

One riser card is used to support a PCI expansion (add-on) card in the system. The SC512F chassis can accommodate one standard size (full height full length) PCI expansion card. When viewed from the chassis front, the card installs to the left rear of the system.

PCI Card Installation

Before installing a PCI add-on card, make sure it is supported by the riser card. Begin by releasing the locking tab that corresponds to the slot you wish to populate. Insert the expansion card into the riser card by pushing down with your thumbs evenly on both sides of the card.

PCI Slot/Card Configuration

Riser Card

RSC-RR1U-E16 (pre-installed)

Expansion card supported

One PCI-E 3.0 x16 card

Connector	Description
JCOM1, JCOM2	COM1 Port, COM2 Header
JIPMB1	System Management Bus Header (for IPMI)
JTPM1	Trusted Platform Module (TPM) Header
JUSB 4/5, 6/7, 8/9	Front Accessible USB Headers
JOH1	Overheat LED/Fan Fail
3-SGPIO1 3-SGPIO2	Serial General Purpose I/O Headers
JUSB2	Type A USB port
S-SATA0~3	SATA 2.0 ports (3Gb/s)
FAN A, FAN 1~4	Fan Headers
I-SATA0/1	SATA 3.0 ports (6Gb/s)
I-SATA2~5	SATA 2.0 ports (3Gb/s)
JPK1	Intel/LSI Software RAID Key Firmware Upgrade Header
T-SGPIO1, T-SGPIO2	Serial General Purpose I/O 1/2 Headers (5V Gen1/Gen 2)
JF1	Control Panel Header
JD1	Power LED/Speaker Header
JL1	Chassis Intrusion Header
JPI2C1	Power Supply SMBus I ² C Header
JPW2	8-pin Secondary Power Connector
JPW1	24-pin Main ATX Power Connector
JLAN_USB12	IPMI LAN Port/Backpanel USB 2.0 Port
JLAN1, JLAN2	Backpanel Gbit LAN Ports 1, 2 (see page 1-10 for feature information)
UID_SW	Unit ID Switch
JSD1	Disk On Module (DOM) Power

LED	Description	Color/State	Status
DP2	Power On LED	Green: Solid On	System is On
DP3	IPMI Heartbeat	Green/Blinking	BMC/IPMI Normal
UID LED	UID (Unit ID) LED	Blue: Solid On	UID: On

5-8 Connector Definitions

Power Connectors

The 24-pin main power connector (JPW1) is used to provide power to the motherboard. The 8-pin CPU power connector (JPW2) is also required for the processor. These power connectors meet the SSI EPS 12V specification. See the tables on the right for pin definitions.

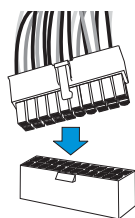

24-Pin Main PWR

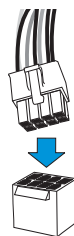

8-Pin Processor PWR

ATX Power 24-pin Connector Pin Definitions (JPW1)			
Pin#	Definition	Pin #	Definition
13	+3.3V	1	+3.3V
14	-12V	2	+3.3V
15	COM	3	COM
16	PS_ON	4	+5V
17	COM	5	COM
18	COM	6	+5V
19	COM	7	COM
20	Res (NC)	8	PWR_OK
21	+5V	9	5VSB
22	+5V	10	+12V
23	+5V	11	+12V
24	COM	12	+3.3V

Processor Power Pin Definitions (JPW2)

Pins	Definition
1 through 4	Ground
5 through 8	+12V

NMI Button

The non-maskable interrupt button header is located on pins 19 and 20 of JF1. Refer to the table on the right for pin definitions.

NMI Button Pin Definitions (JF1)

Pin#	Definition
19	Control
20	Ground

Power LED

The Power LED connection is located on pins 15 and 16 of JF1. Refer to the table on the right for pin definitions.

Power LED Pin Definitions (JF1)

Pin#	Definition
15	+5V
16	Ground

HDD LED

The HDD LED connections are located on pins 13 and 14 of JF1. Attach a cable here to indicate HDD activity. See the table on the right for pin definitions.

HDD LED Pin Definitions (JF1)

Pin#	Definition
13	+5V
14	HD Active

NIC1/NIC2 (LAN1/LAN2)

The NIC (Network Interface Controller) LED connection for LAN port 1 is located on pins 11 and 12 of JF1, and the LED connection for LAN Port 2 is on Pins 9 and 10. NIC1 LED and NIC2 LED are 2-pin NIC LED headers. Attach NIC LED cables to NIC1 LED and NIC2 LED to display network activities for LAN 1 and LAN2. Refer to the table on the right for pin definitions.

LAN1/LAN2 LED Pin Definitions (JF1)	
Pin#	Definition
9/11	Vcc
10/12	Ground

Overheat (OH)/Fan Fail/Front UID LED

Connect an LED cable to the Front UID and OH/Fan Fail connections on pins 7 and 8 of JF1 to display UID (Unit ID) signals or to provide advanced warnings for chassis overheat/fan failure. Refer to the table on the right for pin definitions.

OH/Fan Fail LED Pin Definitions (JF1)	
Pin#	Definition
7	Vcc/Blue UID LED
8	OH/Fan Fail LED

OH/Fan Fail Indicator Status	
State	Definition
Off	Normal
On	Overheat
Flashing	Fan Fail

Reset Button

The Reset Button connection is located on pins 3 and 4 of JF1. Attach it to a the hardware Reset Button on the computer case. Refer to the table on the right for pin definitions.

Reset Button Pin Definitions (JF1)	
Pin#	Definition
3	Reset
4	Ground

Power Fail LED

The Power Fail LED connection is located on pins 5 and 6 of JF1. Refer to the table on the right for pin definitions.

PWR Fail LED Pin Definitions (JF1)	
Pin#	Definition
5	Vcc
6	Ground

Power Button

The Power Button connection is located on pins 1 and 2 of JF1. Momentarily contacting both pins will power on/off the system. This button can also be configured to function as a suspend button (see BIOS Setup). To turn off the power in the suspend mode, press the button for at least 4 seconds. Refer to the table on the right for pin definitions.

Power Button Pin Definitions (JF1)	
Pin#	Definition
1	Signal
2	+3V Standby

Universal Serial Bus (USB)

Two Universal Serial Bus ports (USB 0/1) are located on the I/O backpanel and an additional six USB ports in three headers, USB2/3, 4/5, 12/13 provide front/back chassis access. USB 11 is a Type A USB connector. (USB cables are not included). See the tables on the right for pin definitions.

Back Panel USB0/1 Pin Definitions			
Pin#	Definition	Pin#	Definition
1	+5V	5	+5V
2	USB_PN1	6	USB_PN0
3	USB_PP1	7	USB_PP0
4	Ground	8	Ground

Front/Back Panel USB2/3, 11, 12/13 Pin Definitions			
USB 2/4/11/12		USB 3/5/13	
Pin #	Definition	Pin #	Definition
1	+5V	6	+5V
2	USB_PN2	7	USB_PN3
3	USB_PP2	8	USB_PP3
4	Ground	9	Ground
5	No Connection	10	Key

Serial Ports

The COM1 port is located on the I/O backpanel. COM2 is a header located on the the motherboard. See the table on the right for pin definitions.

Serial Port Pin Definitions (COM1/COM2)			
Pin #	Definition	Pin #	Definition
1	CDC	6	DSR
2	RXD	7	RTS
3	TXD	8	CTS
4	DTR	9	RI
5	Ground	10	NC

Fan Headers

The X9SRi-F has five fan headers (Fan1 ~ Fan4 and FanA). These are all 4-pin fan headers, however pins 1-3 are backward compatible with traditional 3-pin fans. A fan speed control setting in the BIOS (Hardware Monitoring section) allows the BIOS to automatically set fan speeds based on the system temperature. Refer to the table on the right for pin definitions.

Note: Please use all 3-pin fans or all 4-pin fans on a motherboard. Do not mix 3-pin fans and 4-pin fans on the same board.

Fan Header Pin Definitions	
Pin#	Definition
1	Ground (Black)
2	+12V (Red)
3	Tachometer
4	PWM_Control

Chassis Intrusion

A Chassis Intrusion header is located at JL1 on the motherboard. Attach the appropriate cable from the chassis to inform you of a chassis intrusion when the chassis is opened.

Chassis Intrusion Pin Definitions	
Pin#	Definition
1	Intrusion Input
2	Ground

ATX PS/2 Keyboard and PS/2 Mouse Ports

The ATX PS/2 keyboard and the PS/2 mouse ports are located beside the USB ports. See the table on the right for pin definitions.

PS/2 Keyboard and Mouse Ports Pin Definitions	
Pin#	Definition
1	Data
2	NC
3	Ground
4	VCC
5	Clock
6	NC

Speaker (JD1)

On the JD1 header, pins 6~7 are used for the internal speaker. Close pins 6~7 with a jumper or cap to use the onboard speaker. If you wish to use an external speaker, attach the external speaker's cable to pins 1~4. See the table on the right for pin definitions.

Speaker Connector Pin Definitions	
Pin Setting	Definition
Pins 6~7	Internal Speaker
Pins 1~3	PWR LED
Pins 4~7	External Speaker

Trusted Platform Module Header

This header is used to connect a Trusted Platform Module (TPM), available separately from a third-party vendor. A TPM is a security device that allows encryption and authentication of hard drives, disallowing access if the TPM associated with it is not installed in the system. See the table on the right for pin definitions.

Trusted Platform Module Header Pin Definitions			
Pin #	Definition	Pin #	Definition
1	LCLK	2	GND
3	LFRAME	4	No Pin
5	LRESET	6	VCC5
7	LAD3	8	LAD2
9	VCC3	10	LAD1
11	LAD0	12	GND
13	RSV0	14	RSV1
15	SB3V	16	SERIRQ
17	GND	18	CLKRUN
19	LPCPD	20	RSV2

System Management Bus (JIPMB1)

A System Management Bus header for the IPMI slot is located at IPMB. Connect the appropriate cable here to use the IPMB I2C connection on your system.

System Management Bus	
Pin#	Definition
1	Clock
2	Ground
3	Data
4	No Connection

Power Supply I²C Connector

The Power Supply (I²C) connector is located at JPI²C on the motherboard. This connector monitors the status of the power supply, fan and system temperature. See the table on the right for pin definitions.

PWR Supply I ² C Pin Definitions	
Pin#	Definition
1	Clock
2	Data
3	PWR Fail
4	Ground
5	3.3V

Wake-On-LAN

The Wake-On-LAN header is located at JSTBY1 on the motherboard. See the table on the right for pin definitions. (You must also have a LAN card with a Wake-On-LAN connector and cable to use this feature.)

Wake-On-LAN Pin Definitions (JWOL)	
Pin#	Definition
1	+5V Standby
2	Ground
3	Wake-up

T-SGPIO 1/2 & 3-SGPIO 1/2 Headers

Two T-SGPIO (Serial-Link General Purpose Input/Output) headers are located next to the I-SATA ports on the motherboard. Additionally, two 3-SGPIO ports are also located next to JUSB 8/9. These headers are used to communicate with the enclosure management chip in the system. See the table on the right for pin definitions.

Serial_Link-SGPIO Pin Definitions			
Pin#	Definition	Pin	Definition
1	NC	2	NC
3	Ground	4	DATA Out
5	Load	6	Ground
7	Clock	8	NC

DOM PWR Connector

The Disk-On-Module (DOM) power connector, located at JSD1, provides 5V (Gen1/Gen) power to a solid state DOM storage device connected to one of the SATA ports. See the table on the right for pin definitions.

DOM PWR Connector Pin Definitions	
Pin	Definition
1	5V
2	Ground
3	Ground

Unit ID Switch (UID SW)

The rear UID switch, the rear UID LED and front UID LED on JF1 are designed to work together. When the user pushes the rear UID switch, the blue backpanel UID LED and front UID LED will turn on. Push the rear UID switch again to turn off UID LED and the front UID LED. This provides easy identification of a system unit that may be in need of service.

UID Switch	
Pin#	Definition
1	Button In
2	Ground
3	Ground
4	Ground

Internal Buzzer (SP1)

The Internal Buzzer (SP1) can be used to provide audible indications for various beep codes. See the table on the right for pin definitions.

Internal Buzzer Pin Definition		
Pin#	Definitions	
Pin 1	Pos. (+)	Beep In
Pin 2	Neg. (-)	Alarm Speaker

Overheat/Fan Fail LED (JOH1)

The JOH1 header is used to connect an LED to provide warnings of chassis overheat. This LED will also blink to indicate a fan failure. Refer to the tables on right for more information.

Overheat LED Pin Definitions	
Pin#	Definition
1	P3V3
2	OH Active

OH/Fan Fail LED Pin Definitions	
State	Message
Solid	Overheat
Blinking	Fan Fail

5-9 Jumper Settings

Explanation of Jumpers

To modify the operation of the motherboard, jumpers can be used to choose between optional settings. Jumpers create shorts between two pins to change the function of the connector. Pin 1 is identified with a square solder pad on the printed circuit board. See the diagram at right for an example of jumping pins 1 and 2. Refer to the motherboard layout page for jumper locations.

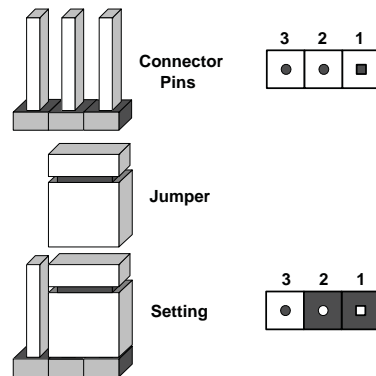

Note: On two-pin jumpers, "Closed" means the jumper is on and "Open" means the jumper is off the pins.

CMOS Clear

JBT1 is used to clear CMOS and will also clear any passwords. Instead of pins, this jumper consists of contact pads to prevent accidentally clearing the contents of CMOS.

To Clear CMOS

1. First power down the system and unplug the power cord(s).
2. With the power disconnected, short the CMOS pads with a metal object such as a small screwdriver.
3. Remove the screwdriver (or shorting device).
4. Reconnect the power cord(s) and power on the system.

Note: Do not use the PW ON connector to clear CMOS.

VGA Enable/Disable

JPG1 allows you to enable or disable the VGA port. The default position is on pins 1 and 2 to enable VGA. See the table on the right for jumper settings.

VGA Enable/Disable Jumper Settings	
Setting	Definition
Pins 1-2	Enabled
Pins 2-3	Disabled

PCI Slot SMB Enable

Use Jumpers JI²C1/JI²C2 to enable PCI-E SMB (System Management Bus) support to improve system management for the PCI-E slots. Default is disabled. See the table on the right for jumper settings.

PCI Slot SMB Enable/Disable Jumper Settings	
Setting	Definition
Closed	Enabled
Open (Default)	Disabled

LAN Port Enable/Disable

Use JPL1/JPL2 to enable or disable LAN Ports 1 and 2 on the motherboard. See the table on the right for jumper settings. The default setting is enabled.

LAN Port En/Disable Jumper Settings	
Setting	Definition
1-2	Enabled
2-3	Disabled

BMC Enable/Disable

JPB is used to enable or disable the BMC (Baseboard Management Control) chip and the onboard IPMI connection. This jumper is used together with the IPMI settings in the BIOS. The default position is on pins 1 and 2 to Enable BMC. See the table on the right for jumper settings.

BMC IPMI Enable/Disable Jumper Settings	
Setting	Definition
Pins 1-2	Enabled
Pins 2-3	Disabled

BIOS Recovery (JPBIOS1)

The BIOS Recovery (JPBIOS) is used to enable or disable the BIOS Recovery feature of the motherboard. Install the jumper on pins 1-2 to begin the recovery process.

BIOS Recovery Jumper Settings	
Setting	Definition
Pins 1-2	Normal
Pins 2-3	Recover

Watch Dog Enable

Watch Dog is a system monitor that can reboot the system when a software application hangs. Close pins 1-2 of JWD1 to reset the system if an application hangs. Close pins 2-3 to generate a non-maskable interrupt signal for the application that hangs. See the table on the right for jumper settings. Watch Dog must also be enabled in the BIOS.

Watch Dog Jumper Settings	
Setting	Definition
Pins 1-2	Reset (default)
Pins 2-3	NMI
Open	Disabled

5-10 Onboard Indicators

LAN1/LAN2 LEDs

The Ethernet ports (located beside the VGA port) have two LEDs. On each Gigabit LAN port, one LED indicates activity when blinking while the other LED may be green, amber or off to indicate the speed of the connection. See the table on the right for the functions associated with the connection speed LED.

LAN LED Connection Speed Indication	
LED State	Definition
Off	No connection or 10 Mb/s
Green	100 Mbps
Amber	1 Gbps

Rear Unit ID LED (UID LED)

The rear Unit ID LED is located at UID LED on the backpanel. This LED is used in conjunction with the rear UID switch to provide easy identification of a system that might be in need of service.

Rear UID LED LED Indication	
Blue: Solid	UID Toggled On

IPMI Heartbeat LED (DP3)

The IPMI Heartbeat LED is located at DP3. When DP3 blinks, the IPMI feature is functioning properly. Refer to the table on the right for details. Also see the layout below for the LED location.

IPMI Heartbeat LED Indicator LED Indication	
Green: Blinking	IPMI is ready for use

Onboard Power LED (DP2)

An Onboard Power LED is located at PWR LED on the motherboard. When PWR LED is on, it means that the AC power cable is connected, the power supply switch and soft switch are on, and the system is running.

Onboard Power LED LED Indication	
Status	Definition
Off	System Off (Soft Switch)
On	System is Running

5-11 SATA Drive Connections

SATA Ports

Ten Serial ATA (SATA) ports (I-SATA 0~5 and S-SATA 1~4) are included on the motherboard. See the table on the right for pin definitions for the onboard SATA ports.

SATA Port Pin Definitions	
Pin #	Definition
1	Ground
2	TXP
3	TXN
4	Ground
5	RXN
6	RXP
7	Ground

5-12 Installing Drivers

After all the hardware and operating system have been installed, you need to install certain drivers. The necessary drivers are all included on the Supermicro CD that came packaged with your motherboard. After inserting this CD into your CD-ROM drive, the display shown in Figure 5-4 should appear. (If this display does not appear, click on the My Computer icon and then on the icon representing your CD-ROM drive. Finally, double click on the S "Setup" icon.)

Figure 5-4. Driver Installation Display Screen

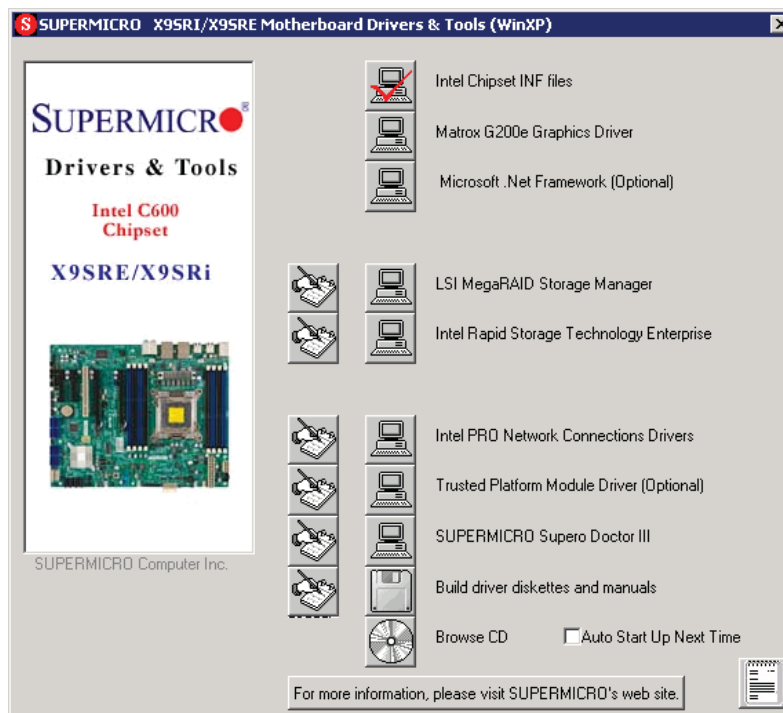

Click the icons showing a hand writing on paper to view the readme files for each item. Click the tabs to the right of these *in order from top to bottom* to install each item one at a time. **After installing each item, you must reboot the system before moving on to the next item on the list.** You should install everything here except for the SUPER Doctor utility, which is optional. The bottom icon with a CD on it allows you to view the entire contents of the CD.

SuperDoctor III

The SuperDoctor® III program is a Web base management tool that supports remote management capability. It includes Remote and Local Management tools. The local management is called SD III Client. The SuperDoctor III program included on the CD-ROM that came with your motherboard allows you to monitor the environment and operations of your system. SuperDoctor III displays crucial system information such as CPU temperature, system voltages and fan status. See the Figure below for a display of the SuperDoctor III interface.

Note: The default User Name and Password for SuperDoctor III is ADMIN / ADMIN.

Note: When SuperDoctor is first installed, it adopts the temperature threshold settings that have been set in BIOS. Any subsequent changes to these thresholds must be made within SuperDoctor, as the SuperDoctor settings override the BIOS settings. To set the BIOS temperature threshold settings again, you would first need to uninstall SuperDoctor.

SuperDoctor III Interface Display Screen (Health Information)



Supero Doctor III Interface Display Screen (Remote Control)

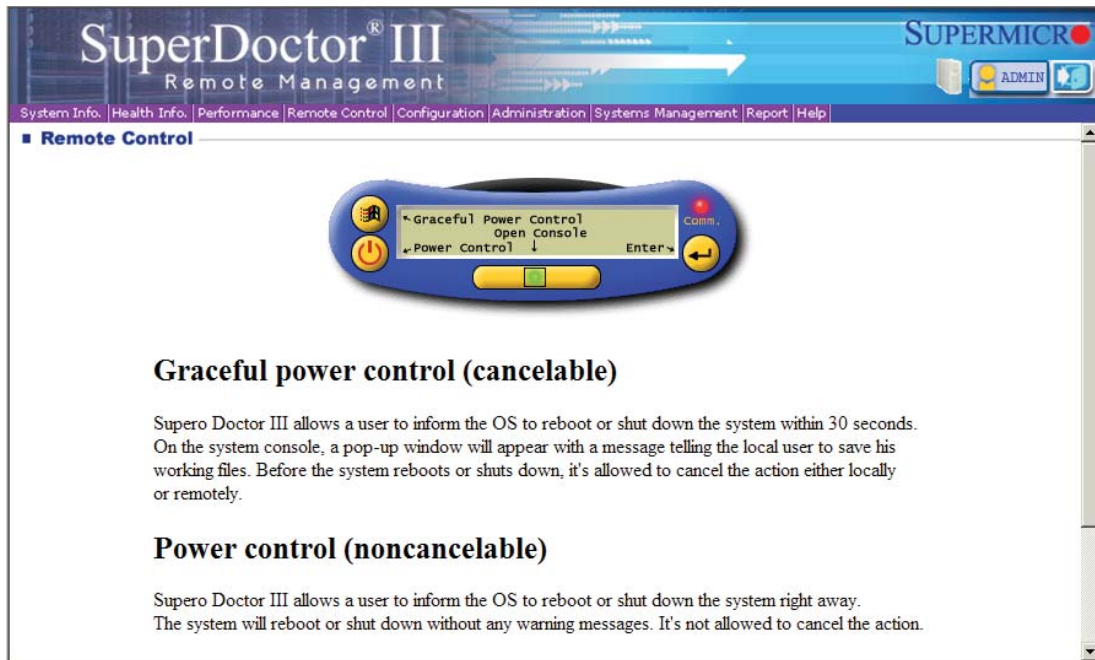

Note: The SuperDoctor III program and User's Manual can be downloaded from the Supermicro web site at <http://www.supermicro.com/products/accessories/software/SuperDoctorIII.cfm>.

For Linux, we recommend using SuperDoctor II.

Chapter 6

Advanced Chassis Setup

This chapter covers the steps required to install components and perform maintenance on the SC512F-350B chassis. For component installation, follow the steps in the order given to eliminate the most common problems encountered. If some steps are unnecessary, skip ahead to the step that follows.

Tools Required: The only tool you will need to install components and perform maintenance is a Philips screwdriver.

6-1 Static-Sensitive Devices

Electrostatic discharge (ESD) can damage electronic components. To prevent damage to any printed circuit boards (PCBs), it is important to handle them very carefully.

The following measures are generally sufficient to protect your equipment from ESD damage.

Precautions

- Use a grounded wrist strap designed to prevent static discharge.
- Touch a grounded metal object before removing any board from its antistatic bag.
- Handle a board by its edges only; do not touch its components, peripheral chips, memory modules or gold contacts.
- When handling chips or modules, avoid touching their pins.
- Put the serverboard, add-on cards and peripherals back into their antistatic bags when not in use.
- For grounding purposes, make sure your computer chassis provides excellent conductivity between the power supply, the case, the mounting fasteners and the serverboard.

Unpacking

The serverboard is shipped in antistatic packaging to avoid static damage. When unpacking the board, make sure the person handling it is static protected.

Figure 6-1. Chassis Views

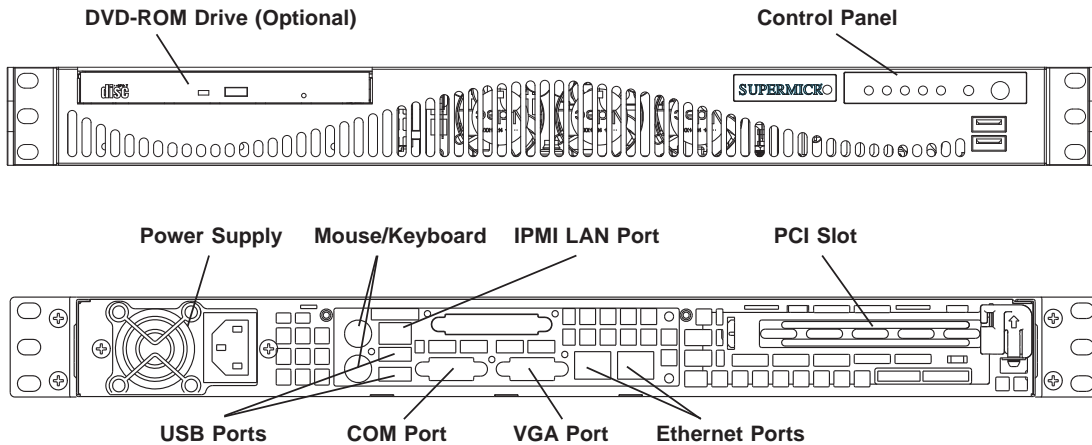

6-2 Control Panel

The control panel (located on the front of the chassis) must be connected to the JF1 connector on the serverboard to provide you with system control buttons and status indicators. These wires have been bundled together in a ribbon cable to simplify the connection.

Connect the cable from JF1 on the serverboard to the Control Panel PCB (printed circuit board). Make sure the red wire plugs into pin 1 on both connectors. Pull all excess cabling out of the airflow path.

The LEDs inform you of system status. See Chapter 3 for details on the LEDs and the control panel buttons. Details on JF1 can be found in Chapter 5.

6-3 System Fans

The 5017R-MF employs two sets of 4-cm counter-rotating fans to provide cooling. Each fan unit is made up of two fans joined back-to-back, which rotate in opposite directions. This counter-rotating action generates exceptional airflow and works to dampen vibration levels. The fans can adjust their speed according to the heat level sensed in the system, which results in more efficient and quieter fan operation. Fan speed is controlled by a setting in BIOS (see Chapter 7). Each fan in a set has its own separate tachometer.

Note: It is very important that the chassis top cover is properly installed for the airflow to circulate properly through the chassis and cool the components.

System Fan Failure

If a fan fails, the remaining fans will ramp up to full speed and the overheat/fan fail LED on the control panel will blink on and off. Replace any failed fan at your earliest convenience with the same type and model (the system can continue to run with a failed fan).

Replacing System Fans (Figure 6-2)

1. Remove the chassis cover to see which fan has failed.
2. Power down the server and remove the AC power cord.
3. Detach the fan wiring then grasp the failed fan unit and lift it out of the chassis.
4. Replace the failed fan with an identical 4-cm, 12 volt fan (see Appendix C).
5. Push the new fan into the vacant space in the housing making sure the arrows on the top of the fan (indicating air direction) point in the same direction as the arrows on the other fans.
6. Reposition the fan housing back over the two mounting posts in the chassis, then reconnect the fan wires to the same chassis fan headers you removed them from.
7. Power up the system and check that the fan is working properly and that the LED on the control panel has turned off. Finish by replacing the chassis cover.

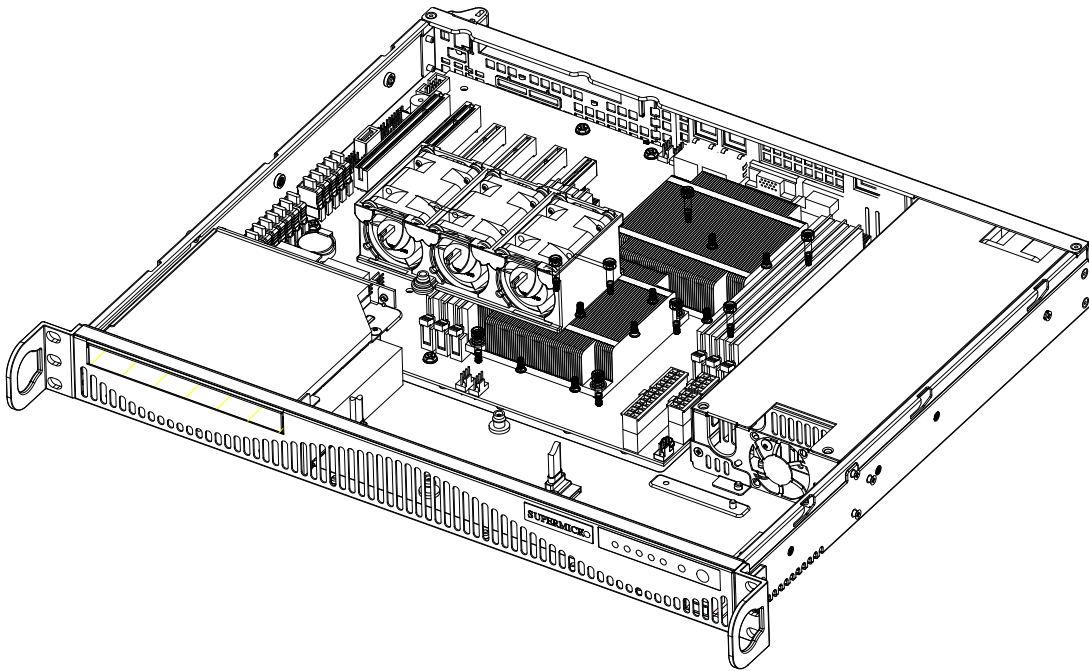
Figure 6-2. System Cooling Fans

Note: different motherboard may be shown than that in the 5017R-MF

6-4 Drive Bay Installation/Removal

Accessing the Drive Bays

DVD-ROM/Serial ATA Drives: For installing or removing the DVD-ROM or SATA drive, you will need to gain access to the inside of the server by removing the top cover of the chassis. **Note:** The DVD drive is optional and does not come pre-installed in the system. Only a "slim" DVD-ROM will fit in the 5017R-MF.

Accessing the Inside of the System

1. Power down the system and remove the AC power cord.
2. Grasp the two handles on either side and pull the unit straight out until it locks (you will hear a "click").
3. Next, remove the screws from the lips on either side of the cover then depress the two buttons on the cover to release it.
4. Push the cover away from you then lift it from the chassis to gain full access to the inside of the server.

Serial ATA Drive Installation

The SATA drive is not hot-swappable, meaning system power must be turned off before installing or removing.

1. First power down the system and then remove the top cover of the chassis as described on page 6-7.
2. Unscrew the retention screw at the top center of the drive, then push the drive tray out from the back until you can grasp and pull it out through the front of the chassis.
3. Remove the drive from the drive tray.
4. To add a new SATA drive, install a drive into the tray with the printed circuit board side facing down and so that the mounting holes align with those in the tray.
5. Secure the drive to the tray with the four screws.
6. Replace the top cover when finished. See Figure 6-3.

Note: the 5017R-MF can accommodate two internal SATA hard drives, one on each side of the fans.



Enterprise level hard disk drives are recommended for use in Supermicro chassis and servers. For information on recommended HDDs, visit the Supermicro Web site at <http://www.supermicro.com/products/nfo/storage.cfm>

DVD-ROM Drive Installation

The top cover of the chassis must be opened to gain full access to the DVD-ROM drive bay. The DVD-ROM must have a "slim" profile to fit into the 5017R-MF. If you cannot remove the top cover with the system remaining in the rack, follow the procedure below.

DVD-ROM Drive Installation

1. First shutdown the system and disconnect the AC power cable.
2. Make sure the system is supported from underneath then remove the front bracket screws that secure the unit to the rack.

3. Carefully lift the server out of the rack.
4. Open the cover by following the procedure described on page 6-4.
5. Remove the screws that secure the DVD-ROM drive to the chassis and then lift the drive out of the chassis. See Figure 6-3.

Figure 6-3. Removing the DVD-ROM Drive

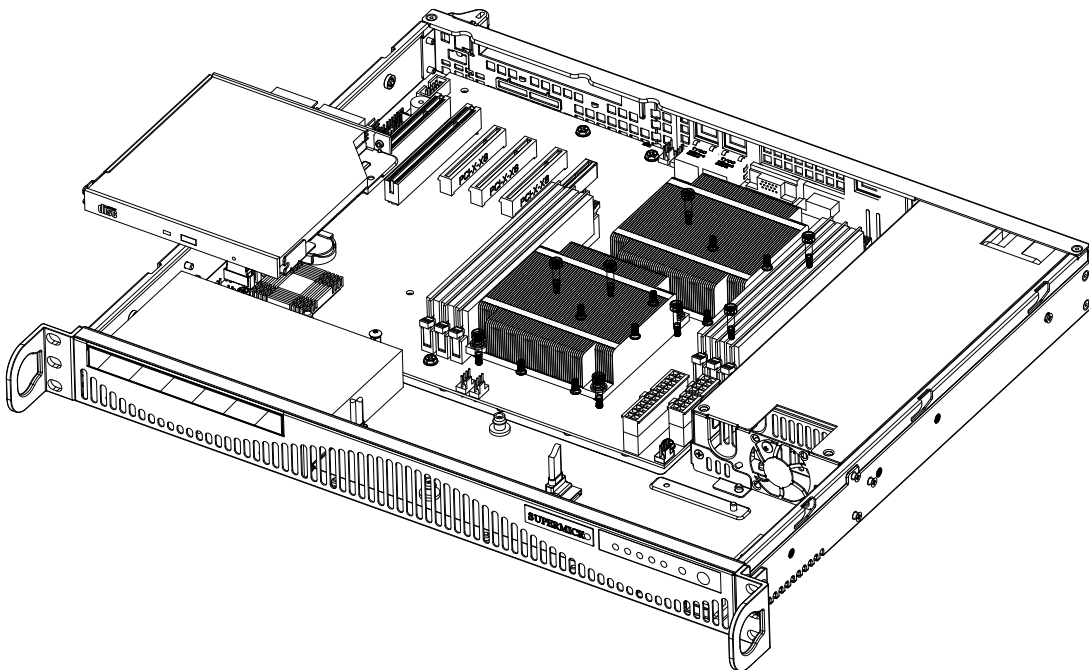

6-5 Power Supply

The 5017R-MF has a single 350 watt power supply. This power supply has the capability of operating at a 100 or 240 input voltage. You must power down the system and then unplug the AC power cord to completely remove power from the system before removing the power supply.

Power Supply Failure

If the power supply unit fails, the system will shut down and you will need to replace the power supply unit. Replacement units can be ordered directly from Supermicro (see part numbers in Appendix C and contact information in Chapter 1).

Accessing the Inside of the System

1. Power down the system and remove the AC power cord.
2. Grasp the two handles on either side and pull the unit straight out until it locks (you will hear a "click").
3. Next, remove the screws from the lips on either side of the cover then depress the two buttons on the cover to release it.
4. Push the cover away from you then lift it from the chassis to gain full access to the inside of the server.

Replacing the Power Supply

1. To remove the failed power unit, remove the two screws on the back of the power supply and a third from the front of the power supply, which secures it to the bottom of the chassis.
2. Lift the unit straight out of the chassis. (The power cord should have already been removed.)
3. Replace the failed unit with another unit of the same wattage. You must replace it with the exact same power supply.
4. Carefully insert the new unit into position in the chassis and secure it with the two screws at the rear of the unit and the third at the front.

5. Reconnect the power cord, replace the chassis top cover and push the unit back into the rack.
6. Finish by turning on the power switch on the power supply, then depress the power button on the front of the system.

Chapter 7

BIOS

7-1 Introduction

This chapter describes the AMI BIOS Setup Utility for the X9SRi/X9SRE motherboard Series. The AMI ROM BIOS is stored in a Flash EEPROM and can be easily updated. This chapter describes the basic navigation of the AMI BIOS Setup Utility setup screens.



Note: For instructions on BIOS recovery, please refer to the instruction guide posted at <http://www.supermicro.com/support/manuals/>.

Starting BIOS Setup Utility

To enter the AMI BIOS Setup Utility screens, press the <Delete> key while the system is booting up.



Note: In most cases, the <Delete> key is used to invoke the AMI BIOS setup screen. There are a few cases when other keys are used, such as <F1>, <F2>, etc.

Each main BIOS menu option is described in this manual. The Main BIOS setup menu screen has two main frames. The left frame displays all the options that can be configured. Grayed-out options cannot be configured. Options in blue can be configured by the user. The right frame displays the key legend. Above the key legend is an area reserved for a text message. When an option is selected in the left frame, it is highlighted in white. Often a text message will accompany it. (**Note:** the AMI BIOS has default text messages built in. Supermicro retains the option to include, omit, or change any of these text messages.)

The AMI BIOS Setup Utility uses a key-based navigation system called "hot keys". Most of the AMI BIOS setup utility "hot keys" can be used at any time during the setup navigation process. These keys include <F1>, <F10>, <Enter>, <ESC>, arrow keys, etc.



Note: Options printed in **Bold** are default settings.

How To Change the Configuration Data

The configuration data that determines the system parameters may be changed by entering the AMI BIOS Setup utility. This Setup utility can be accessed by pressing at the appropriate time during system boot.

How to Start the Setup Utility

Normally, the only visible Power-On Self-Test (POST) routine is the memory test. As the memory is being tested, press the <Delete> key to enter the main menu of the AMI BIOS Setup Utility. From the main menu, you can access the other setup screens. An AMI BIOS identification string is displayed at the left bottom corner of the screen, below the copyright message.



Warning! Do not upgrade the BIOS unless your system has a BIOS-related issue. Flashing the wrong BIOS can cause irreparable damage to the system. In no event shall Supermicro be liable for direct, indirect, special, incidental, or consequential damages arising from a BIOS update. If you have to update the BIOS, do not shut down or reset the system while the BIOS is updating. This is to avoid possible boot failure.

7-2 Main Setup

When you first enter the AMI BIOS Setup Utility, you will enter the Main setup screen. You can always return to the Main setup screen by selecting the Main tab on the top of the screen. The Main BIOS Setup screen is shown below.

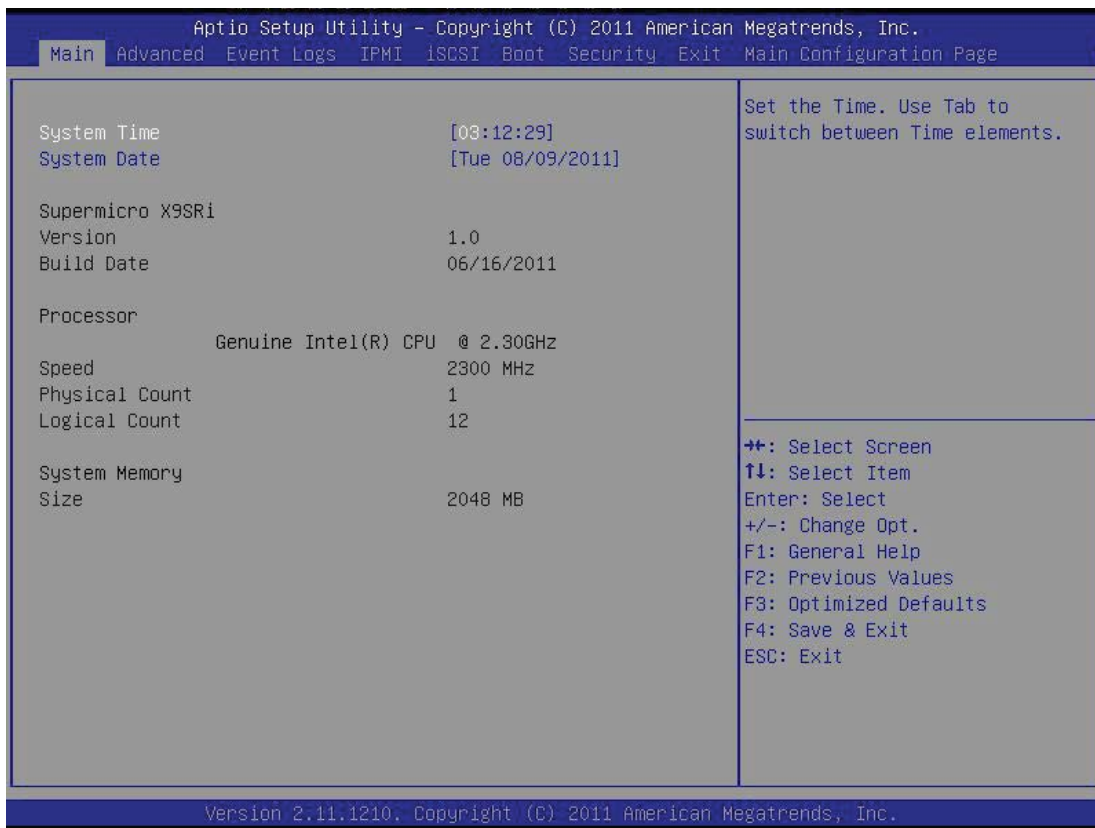

System Overview: The following BIOS information will be displayed:

System Time/System Date

Use this option to change the system time and date. Highlight *System Time* or *System Date* using the arrow keys. Enter new values through the keyboard. Press the <Tab> key or the arrow keys to move between fields. The date must be entered in Day MM/DD/YY format. The time is entered in HH:MM:SS format. (**Note:** The time is in the 24-hour format. For example, 5:30 P.M. appears as 17:30:00.)

Supermicro X9SRi/X9SRE Motherboard Series

Version

Build Date

Processor

The AMI BIOS will automatically display the status of processor as shown below:

Processor

Speed

Physical Count

Logical Count

System Memory

This displays the size of memory available in the system:

Size

7-3 Advanced Setup Configurations

Use the arrow keys to select Boot Setup and hit <Enter> to access the submenu items:

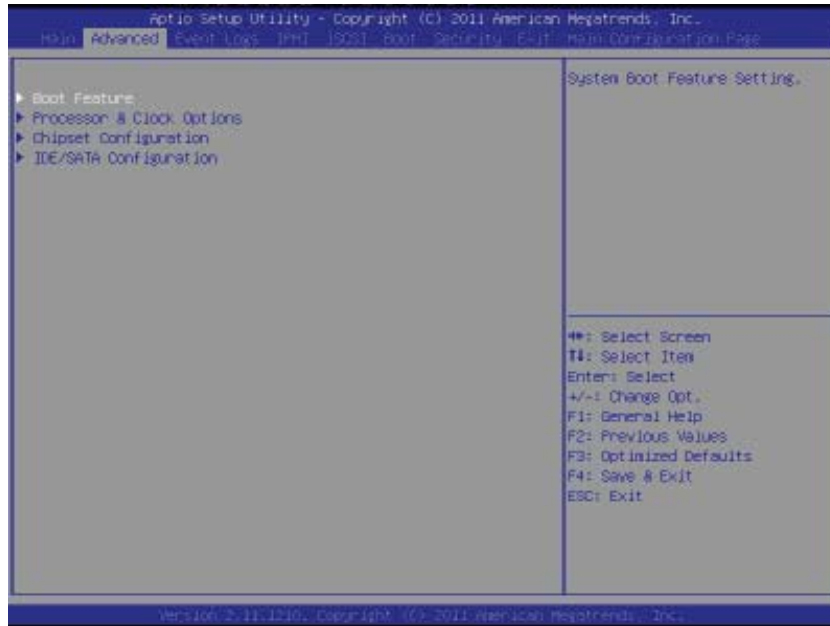

►BOOT Feature

Quiet Boot

This option allows the bootup screen options to be modified between POST messages or the OEM logo. Select Disabled to display the POST messages. Select Enabled to display the OEM logo instead of the normal POST messages. The options are **Enabled** and Disabled.

AddOn ROM Display Mode

This sets the display mode for Option ROM. The options are **Force BIOS** and Keep Current.

Bootup Num-Lock

This feature selects the Power-on state for Numlock key. The options are Off and **On**.

Wait For 'F1' If Error

This forces the system to wait until the 'F1' key is pressed if an error occurs. The options are Disabled and **Enabled**.

Interrupt 19 Capture

Interrupt 19 is the software interrupt that handles the boot disk function. When this item is set to Enabled, the ROM BIOS of the host adaptors will "capture" Interrupt

19 at boot and allow the drives that are attached to these host adaptors to function as bootable disks. If this item is set to Disabled, the ROM BIOS of the host adaptors will not capture Interrupt 19, and the drives attached to these adaptors will not function as bootable devices. The options are **Enabled** and Disabled.

Watch Dog Function

If enabled, the Watch Dog Timer will allow the system to reboot when it is inactive for more than 5 minutes. The options are Enabled and **Disabled**.

Power Button Function

This feature controls how the system shuts down when the power button is pressed. Select 4-Second Override to force the user to press and hold the Power Button for 4 seconds before the system turns off. Select Instant Off if you want the system to instantly power off when the Power Button is pressed. The options are 4 Second Override and **Instant Off**.

Restore on AC Power Loss

Use this feature to set the power state after a power outage. Select Power-Off for the system power to remain off after a power loss. Select Power-On for the system power to be turned on after a power loss. Select Last State to allow the system to resume its last state before a power loss. The options are Power-On, Power-Off and **Last State**.

VFC

This item enables or disables the VESA Feature Connector (VFC) option. The options are **Enabled** and Disabled.

► Processor & Clock Options



Warning: Take Caution when changing the Advanced settings. An incorrect value, a very high DRAM frequency or incorrect DRAM timing may cause system to become unstable. When this occurs, revert to the default setting.

Clock Spread Spectrum

Select Enable to use the feature of Clock Spectrum, which will allow the BIOS to monitor and attempt to reduce the level of Electromagnetic Interference caused by the components whenever needed. Select Disabled to enhance system stability. The options are **Disabled** and Enabled.

Hardware Prefetcher (Available when supported by the CPU)

If set to Enabled, the hardware pre fetcher will pre fetch streams of data and instructions from the main memory to the L2 cache in the forward or backward manner to improve CPU performance. The options are Disabled and **Enabled**.

Adjacent Cache Line Prefetch (Available when supported by the CPU)

The CPU fetches the cache line for 64 bytes if this option is set to Disabled. The CPU fetches both cache lines for 128 bytes as comprised if **Enabled**.

MPS and ACPI MADT Ordering

This feature allows the user to choose the method of ordering for the Multiple APIC Description Table (MADT). Select Modern Ordering if you have the Microsoft Windows XP or later version of the OS. Select Legacy Ordering if you use Microsoft Windows 2000 or earlier version of the OS. The options are **Modern Ordering** and Legacy Ordering.

Intel® Virtualization Technology (Available when supported by the CPU)

Select Enabled to use the feature of Virtualization Technology to allow one platform to run multiple operating systems and applications in independent partitions, creating multiple "virtual" systems in one physical computer. The options are **Enabled** and Disabled. **Note:** If there is any change to this setting, you will need to power off and restart the system for the change to take effect. Please refer to Intel's web site for detailed information.

Execute-Disable Bit Capability (Available when supported by the OS and the CPU)

Set to Enabled to enable the Execute Disable Bit which will allow the processor to designate areas in the system memory where an application code can execute and where it cannot, thus preventing a worm or a virus from flooding illegal codes to overwhelm the processor or damage the system during an attack. The default is **Enabled**. (Refer to Intel and Microsoft Web Sites for more information.)

Limit CPUID Maximum

This feature allows the user to set the maximum CPU ID value. Enable this function to boot the legacy operating systems that cannot support processors with extended CPUID functions. The options are Enabled and **Disabled** (for the Windows OS.).

Intel® Hyper Threading Technology

Set to Enabled to use the processor's Hyper Threading Technology feature. The options are **Enabled** and Disabled.

Active Processor Cores

Set to Enabled to use a processor's Second Core and beyond. (Please refer to Intel's web site for more information.) The options are **All**, 1, 2 and 3.

Power Technology

This feature determines what power-saving scheme the motherboard uses. The options are Disabled, **Energy Efficient** and Custom. If Custom is selected, the following options become available:

EIST

EIST (Enhanced Intel SpeedStep Technology) allows the system to automatically adjust processor voltage and core frequency in an effort to reduce power consumption and heat dissipation. **Please refer to Intel's web site for detailed information.** The options are **Disabled** and Enabled.

P-STATE Coordination

This feature selects the type of coordination for the P-State of the processor. P-State is a processor operational state that reduces the processor's voltage and frequency. This makes the processor more energy efficient, resulting in further gains. The options are **HW_ALL**, **SW_ALL** and **SW-ANY**.

CPU C3 Report, CPU C6, CPU C7 Report

This BIOS feature enables or disables C3 (ACPI C2), C6 (ACPI C3), C7 (ACPI C3) reporting to the operating system. The options are **Disabled** and Enabled.

Package C State Limit

If set to Auto, the AMI BIOS will automatically set the limit on the C-State package register. The options are **C0**, C1, C6, C7 and No Limit.

►Intel® Turbo Boost Technology (Available if Intel® EIST technology is Enabled)

Turbo Mode

This feature allows processor cores to run faster than marked frequency in specific conditions. The options are Disabled and **Enabled**.

Long duration power limit - this is the processor power consumption limit (in Watts) during a long duration time window.

Long duration maintained - this is the time in milliseconds where the Long Duration Power Limit is maintained.

Short duration power limit - During Turbo Mode, the system may exceed the processor's default power setting and exceed the Short Duration Power limit. By increasing this value, the processor can provide better performance for a short duration.

DRAM RAPL - this feature enables DRAM Running Average Power Limit. The options are Disabled, Mode 0, and **Mode 1**.

►Chipset Configuration

WARNING: Setting the wrong values in the following sections may cause the system to malfunction.

►North Bridge Configuration

This item displays the current IO chipset Revision.

Intel I/OAT

The Intel I/OAT (I/O Acceleration Technology) significantly reduces CPU overhead by leveraging CPU architectural improvements, freeing resources for more other tasks. The options are **Disabled** and Enabled.

Select the TargetVGA

Use this option to select the target VGA device. The options are the currently installed VGA devices.

DCA Support

This feature accelerates the performance of I/O devices using Direct Cache Access. The options are **Enabled** and Disabled.

VT-d

Select Enabled to enable Intel's Virtualization Technology support for Direct I/O VT-d by reporting the I/O device assignments to VMM through the DMAR ACPI Tables. This feature offers fully-protected I/O resource-sharing across the Intel platforms, providing the user with greater reliability, security and availability in networking and data-sharing. The settings are Enabled and **Disabled**.

IOU1 - PCIe Port

This feature enables the user to select bifurcation mode for the selected root port. The options are **x4x4** and x8.

Link Speed

This feature enables the user to select the target link speed for the port above. The options are GEN1, GEN2 and **GEN3**.

IOU2 - PCIe Port

This feature enables the user to select bifurcation mode for the selected root port. The options are x4x4x4x4, x4x4x8, x8x4x4, x8x8 and **x16**.

Link Speed

This feature enables the user to select the target link speed for the port above. The options are GEN1, GEN2 and **GEN3**.

IOU3 - PCIe Port

This feature enables the user to select bifurcation mode for the selected root port. The options are x4x4x4x4, x4x4x8, x8x4x4, **x8x8** and x16.

Link Speed

This feature enables the user to select the target link speed for the port above. The options are GEN1, GEN2 and **GEN3**.

Active State Power Management

Select Enabled to enable Active-State Power Management for signal transactions between L0 and L1 Links on the PCI Express Bus in order to maximize power-saving and transaction speeds. The options are Enabled and **Disabled**.

PCIe Maximum Payload Size

This feature selects the setting of the PCIe maximum payload size. The options are **Auto**, 128 Bytes, 256 Bytes, 512 Bytes, 1024 Bytes, 2048 Bytes, and 4096 Bytes.

Memory Mode

The options are **Independent**, Mirroring, Lockstep and Sparing.

Independent - All DIMMs are available to the operating system.

Mirroring - The motherboard maintains two identical copies of all data in memory for redundancy.

Lockstep - The motherboard uses two areas of memory to run the same set of operations in parallel.

Sparing - A preset threshold of correctable errors is used to trigger fail-over. The spare memory is put online and used as active memory in place of the failed memory.

NUMA Support

This feature enables the Non-Uniform Memory Access ACPI support. The options are **Enabled** and Disabled.

DDR Speed

Use this option to force the system memory to run at a different frequency than the default frequency. The available options are **Auto**, Force DDR-800, Force DDR-1066, Force DDR-1333, and Force DDR3-1600.

Channel Interleaving

This feature selects from the different channel memory interleaving methods. The options are **Auto**, 1 Way, 2 Way, 3 Way and 4 Way.

Rank Interleaving

This feature selects from the different rank memory interleaving methods. The options are **Auto**, 1 Way, 2 Way, 3 Way, 4 Way and 8 Way.

Patrol Scrub

Patrol Scrubbing is a process that allows the CPU to correct correctable memory errors detected on a memory module and send the correction to the requestor (the original source). When this item is set to Enabled, the North Bridge will read and write back one cache line every 16K cycles, if there is no delay caused by internal processing. By using this method, roughly 64 GB of memory behind the North Bridge will be scrubbed every day. The options are **Enabled** and Disabled.

Demand Scrub

Demand Scrubbing is a process that allows the CPU to correct correctable memory errors found on a memory module. When the CPU or I/O issues a demand-read command, and the read data from memory turns out to be a correctable error, the error is corrected and sent to the requestor (the original source). Memory is updated as well. Select Enabled to use Demand Scrubbing for ECC memory correction. The options are Enabled and **Disabled**.

Rank Margin

This feature enables or disables Rank Margin. The options are Enabled and **Disabled**.

Thermal Throttling

This feature selects from the different throttling methods. The options are Disabled, OLTT and **CLTT**.

OLTT - Open Loop Thermal Throttling.

CLTT - Closed Loop Thermal Throttling.

► South Bridge Configuration

This item displays the current South Bridge Revision.

SLP_S4 Assertion Stretch Enable

This feature enables or disables Assertion Stretch. The options are **Enabled**, and Disabled.

Assertion Width

This feature selects the Assertion Width. The options are 1-2 Seconds, 2-3 Seconds, 3-4 Seconds and **4-5 Seconds**.

Deep Sx

Select Enabled to enable Deep Sleep State support. The settings are Enabled and **Disabled**.

Legacy USB Support

This feature enables support for legacy USB devices. Select Auto to disable legacy support if USB devices are not present. Select Disable to have USB devices available only for EFI applications. The options are **Enabled**, Disabled and Auto.

BIOS EHCI Hand-Off

This item is for Operating Systems that does not support Enhanced Host Controller Interface (EHCI) hand-off. When enabled, EHCI ownership change will be claimed by the EHCI driver. The settings are **Enabled** and Disabled.

► IDE/SATA Configuration

When this submenu is selected, the AMI BIOS automatically detects the presence of the IDE Devices and displays the following items:

SATA Mode

This item selects the mode for the installed drives. The options are Disabled, IDE Mode, **AHCI Mode** and RAID Mode. The following are displayed depending on your selection:

IDE Mode

The following items are displayed when IDE Mode is selected:

Serial-ATA Controller 0~1

This feature is used to activate/deactivate the SATA controller, and sets the compatibility mode. The options are Enhanced and **Compatible**. The default of Serial-ATA Controller 1 is **Enhanced**.

SATA Port0~Port5

This item displays the information detected on the installed SATA drives on the particular SATA port.

AHCI Mode

The following items are displayed when AHCI Mode is selected:

Aggressive Link Power Management

This feature Enables or Disables Aggressive Link Power Management support for Cougar Point B0 stepping and later. The options are **Enabled** and Disabled.

SATA Port0~Port5

This item displays the information detected on the installed SATA drives on the particular SATA port.

Staggered Spin Up

Set this item to Enabled to enable Staggered Spin-up support. The options are Enabled and **Disabled**.

External SATA Port

Set this item to Enabled to enable eSATA support. The options are Enabled and **Disabled**.

Hot Plug

Set this item to Enabled to enable hot-plugging. The options are Enabled and **Disabled**.

RAID Mode

The following items are displayed when RAID Mode is selected:

SATA Port0~Port5

This item displays the information detected on the installed SATA drives on the particular SATA port.

Hot Plug

Set this item to Enabled to enable hot-plugging. The options are Enabled and **Disabled**.

►PCIe/PCI/PnP Configuration

This feature allows the user to set the PCI/PnP configurations for the following items:

PCI ROM Priority

In case of multiple Option ROMs (Legacy and EFI-compatible), this feature specifies what ROM to launch. The options are **Legacy ROM** and EFI Compatible ROM.

PCI Latency Timer

This feature sets the latency Timer of each PCI device installed on a PCI bus. Select 64 to set the PCI latency to 64 PCI clock cycles. The options are 32 PCI Bus Clocks, **64 PCI Bus Clocks**, 96 PCI Bus Clocks, 128 PCI Bus Clocks, 160 PCI Bus Clocks, 192 PCI Bus Clocks, 224 PCI Bus Clocks and 248 PCI Bus Clocks.

PCIX Slots 1, 2, 3 and PCI-E Slots 4, 5, 6 OPRM

Use this feature to enable or disable PCI slot Option ROMs. The options are Disabled and **Enabled**.

Onboard LAN Option ROM Select

This feature selects whether to load the iSCSI or PXE onboard LAN option ROM. The options are iSCSI and **PXE**.

Load Onboard LAN1 Option ROM/Load Onboard LAN2 Option ROM

This feature is to enable or disable the onboard option ROMs. The options are **Disabled** and Enabled.

Boot Graphics Adapter Priority

This option allows the user to specify which graphics controller to be used as the primary boot device. The options are Slot 6 VGA, **Other Slot VGA** and Onboard VGA.

Load SAS Option ROM

This feature selects whether to load the SAS option ROM. The options **Enabled** and Disabled.

► Super IO Device Configuration

Serial Port 1 / Serial Port 2

Select Enabled to enable the onboard serial port. The options are **Enabled** and Disabled.

Serial Port1 Settings/ Serial Port2 Settings

This option specifies the base I/O port address and the Interrupt Request address of Serial Port 1 and Serial Port 2. Select Disabled to prevent the serial port from accessing any system resources. When this option is set to Disabled, the serial port physically becomes unavailable. Select 3F8/IRQ4 to allow the serial port to use 3F8 as its I/O port address and IRQ 4 for the interrupt address.

The options for Serial Port1 are:

Auto,

IO=3F8h; IRQ=4;

IO=3F8h; IRQ=3, 4, 5, 6, 7, 10, 11, 12;

IO=2F8h; IRQ=3, 4, 5, 6, 7, 10, 11, 12;

IO=3E8h; IRQ=3, 4, 5, 6, 7, 10, 11, 12;

IO=2E8h; IRQ=3, 4, 5, 6, 7, 10, 11, 12;

The options for Serial Port2 are:

Auto,

IO=2F8h; IRQ=3;

IO=3F8h; IRQ=3, 4, 5, 6, 7, 10, 11, 12;

IO=2F8h; IRQ=3, 4, 5, 6, 7, 10, 11, 12;

IO=3E8h; IRQ=3, 4, 5, 6, 7, 10, 11, 12;

IO=2E8h; IRQ=3, 4, 5, 6, 7, 10, 11, 12;

Serial Port 2 Mode

Use this feature to configure Serial Port 2 mode. The options are **Normal**, IrDA and ASK IR. IrDA (Infrared Data) is an industry standard for remote control devices. ASK IR (Amplitude Shifted Keying Infrared) is a protocol compatible with Sharp® branded PDAs and other infrared devices.

PS/2 KB/MS WakeUp

This feature is used to awaken the system from Standby mode by a PS/2 mouse click or PS/2 keyboard keystroke. The options are **S1 (OS Control)**, S5 (OS Control), Force Enable, and Force Disable.

► Remote Access Configuration

COM1/COM2/SOL Console Redirection

Use this feature to enable console redirection for COM0 and COM1 ports. The options are **Enabled** and Disabled. The default for all ports are Disabled.

► Console Redirection Settings

Configure the following options for the Console Redirection Settings. The most common settings are set as default:

Terminal Type : Select **ANSI**, VT100, VT100+, or VT-UTF8

Bits per Second (BPS): 9600, 19200, 57600, or **115200**

Data Bits: **8** or 7

Parity: **None**, Even, Odd, Mark, or Space

Stop Bits: **1** or 2

Flow Control: **None** or Hardware RTS/CTS

Recorder Mode: **Disabled** or Enabled

Resolution 100x31: **Disabled** or Enabled

Legacy OS Redirection Resolution: 80x24 or **80x25**

Serial Port for Out-of-Band Management / Windows Emergency Management Services (EMS)

Use this feature to enable console redirection. The options are **Enabled** and Disabled. The default is Disabled.

► Console Redirection Settings

Configure the following options for the Console Redirection Settings. The most common settings are set as default:

Out-of-Band Mgmt Port: **COM1**, COM2, SOL

Terminal Type : Select ANSI, VT100, VT100+, or **VT-UTF8**

Bits per Second (BPS): 9600, 19200, 57600, or **115200**

Flow Control: **None**, Hardware RTS/CTS, Software Xon/Xoff

Data Bits: **8** or 7

Parity: **None**, Even, Odd, Mark, or Space

Stop Bits: **1** or 2

►Hardware Health Configuration

Fan Speed Control Mode

This feature allows the user to decide how the system controls the speeds of the onboard fans. The CPU temperature and the fan speed are correlative. When the CPU on-die temperature increases, the fan speed will also increase for effective system cooling. Select "Full Speed" to allow the onboard fans to run at full speed (of 100% Pulse Width Modulation Duty Cycle) for maximum cooling. This setting is recommended for special system configuration or debugging. Select "Standard" for the onboard fans to run at 50% of the Initial PWM Cycle in order to balance the needs between system cooling and power saving. This setting is recommended for regular systems with normal hardware configurations. Select "Optimal" for the onboard fans to run at 30% of the Initial PWM Cycle for best power efficiency and maximum quietness. The options are Full Speed (@100% of PWM Cycle), **Standard** (@50% of PWM Cycle), and Optimal (@30% of PWM Cycle).

CPU Temperature Display Mode

This feature displays the CPU temperature detected by DTS (i.e., +34°C) or temperature status in text ("Low", "Medium" or "High"). The options are **Text Mode** or DTS.

CPU Temperature

If Text Mode is selected, the CPU Temperature Display Mode will show the CPU temperature status as follows:

Low – This level is considered as the 'normal' operating state. The CPU temperature is well below the CPU 'Temperature Tolerance'. The motherboard fans and CPU will run normally as configured in the BIOS (Fan Speed Control).

User intervention: No action required.

Medium – The processor is running warmer. This is a 'precautionary' level and generally means that there may be factors contributing to this condition, but the CPU is still within its normal operating state and below the CPU 'Temperature Tolerance'. The motherboard fans and CPU will run normally as configured in the BIOS. The fans may adjust to a faster speed depending on the Fan Speed Control settings.

User intervention: No action is required. However, consider checking the CPU fans and the chassis ventilation for blockage.

High – The processor is running hot. This is a ‘caution’ level since the CPU’s ‘Temperature Tolerance’ has been reached (or has been exceeded) and may activate an overheat alarm:

The information provided above is for your reference only. For more information on thermal management, please refer to Intel’s Web site at www.Intel.com.

System Temperature / Peripheral Temperature

This feature displays the system and peripheral device temperatures, as detected by the motherboard sensors.

Fan1 ~ Fan5 Speed

This feature displays the fan speed readings from fan interfaces Fan1 through Fan4 and FanA.

12V, VDIMM, 5VCC, CPU VTT, AVCC, 3.3VCC, VSB, VBAT

This feature displays the current voltages of the above voltage monitors.

►ACPI Configuration

Use this feature to configure Advanced Configuration and Power Interface (ACPI) power management settings for your system.

High Precision Event Timers

Select Enabled to activate the High Performance Event Timer (HPET) that produces periodic interrupts at a much higher frequency than a Real-time Clock (RTC) does in synchronizing multimedia streams, providing smooth playback and reducing the dependency on other timestamp calculation devices, such as an x86 RDTSC Instruction embedded in the CPU. The High Performance Event Timer is used to replace the 8254 Programmable Interval Timer. The options are **Enabled** and Disabled.

Suspend Mode

This setting allows you to configure the ACPI (Advanced Configuration and Power Interface) sleep state for your system when it is in the Suspend mode. The options are Suspend Disabled, and **S1 (POS)**.

WHEA Support

This feature Enables the Windows Hardware Error Architecture (WHEA) support for the Windows 2008 operating system (and later versions). The options are **Enabled** and Disabled.

►Network Stack

Use this feature to enable or disable the network stack (PXE and UEFI). The options are **Disabled** and Enabled.

►ME Subsystem

Use this feature to disable or enable the ME (Management Engine) Subsystem. This section also displays the current status of the ME Subsystem. The options are **Disabled** and Enabled.

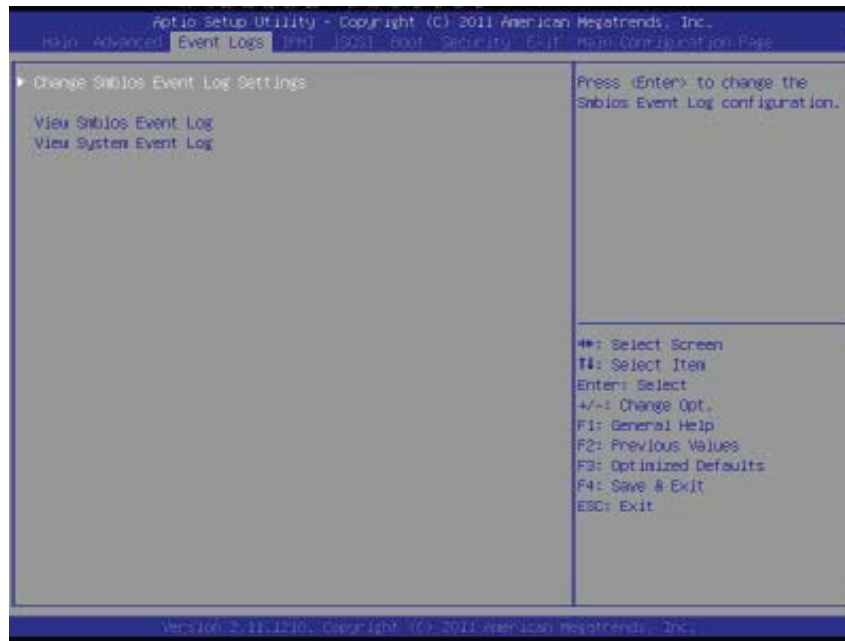

7-4 Event Logs

Smbios Event Log

Change this item to enable or disable all features of the Smbios Event Logging during boot. The options are **Enabled** and Disabled.

Runtime Error Logging Support

Change this item to enable or disable runtime error logging. The options are **Enabled** and Disabled.

PCI Error Logging Support

Change this item to enable or disable runtime error logging. The options are Enabled and **Disabled**.

Memory Correction Error Threshold

Change this item to define the system's memory correction error threshold. Directly enter a numeric value, **default is 10**.

Erase Event Log

This option erases all logged events. The options are **No**, Yes, Next reset and Yes, Every reset.

When Log is Full

This option automatically clears the Event Log memory of all messages when it is full. The options are **Do Nothing** and Erase Immediately.

MECI

The Multiple Event Count Increment (MECI) counter counts the number of occurrences a duplicate event must happen before the MECI counter is incremented. This is a numeric value.

METW

The Multiple Event Time Window (METW) defines number of minutes must pass between duplicate log events before MECI is incremented. This is in minutes, from 0 to 99.

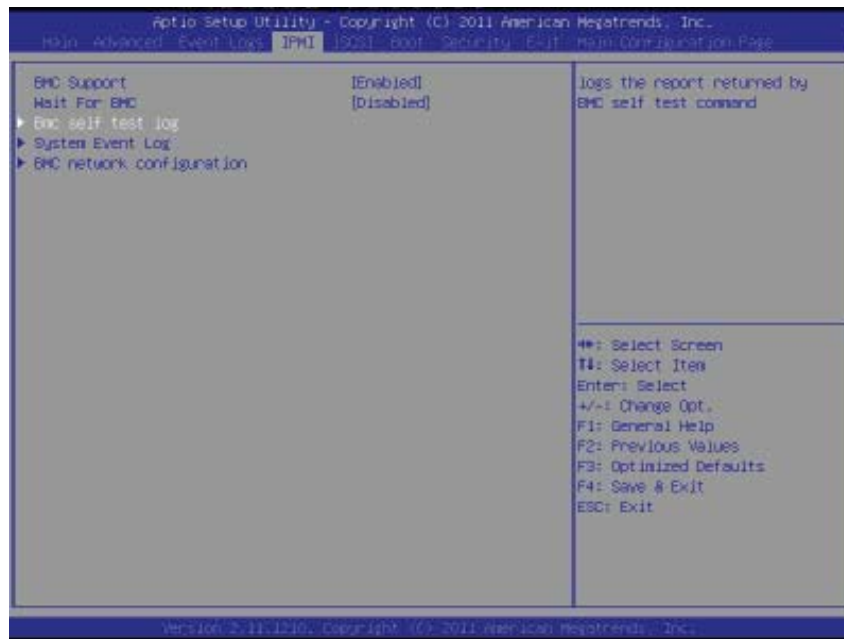

7-5 IPMI

Intelligent Platform Management Interface (IPMI) is a set of common interfaces that IT administrators can use to monitor system health and to manage the system as a whole. For more information on the IPMI specifications, please visit Intel's website at www.intel.com.

BMC Support

This feature enables or disables the installed Baseboard Management Controller (BMC) on the motherboard. The options are **Enabled** and Disabled.

Wait For BMC

If enabled, the system will wait for a BMC response after the AC power is turned on. It takes around 30 seconds to initialize Host to BMC interfaces. The options are **Disabled** and Enabled.

►BMC Self Test Log

This feature logs any BMC messages returned during a BMC self-test. It shows the total number of entries and will allow the viewing of each event by scrolling down.

Erase Log - Select **Yes, On every reset** or No.

When Log is Full - Select **Clear Log** or Do Not Log Anymore.

►System Event Log

This feature is used to change the System Event Log (SEL) configuration.

SEL Components - Change this item to enable or disable all features of System Event Logging. The options are Enabled and Disabled. When Enabled, the following can be configured:

Erase SEL - This option erases all logged SEL events. The options are No, Yes, On Next reset and Yes, On Every reset.

When SEL Full

This option automatically clears the System Event Log memory of all messages when it is full. The options are **Do Nothing** and Erase Immediately.

Log EFI Status Codes

This option enables or disables the logging of Extensible Firmware Interface (EFI) status codes. The options are Disabled, **Both**, Error Code and Progress Code.

►BMC Network Configuration

Set this feature to configure the IPMI LAN adapter with a network address.

Configuration Source

This feature selects whether the IP address, Subnet Mask and Gateway Address are automatically assigned by the network's DHCP server (Dynamic Host and Configuration Protocol) "Dynamic" or manually entered by the user "Static". If Static is selected, the IP Address, Subnet Mask and Gateway Address must be manually entered below. When Dynamic is selected, all the options below are automatically assigned to the system by itself or by an external DHCP server.

The options are **Unspecified**, Static, Dynamic-obtained by BMC, Dynamic-Loaded by BIOS, and Dynamic-BMC running other Protocol. The following items are displayed when Static is selected:

Station IP Address - Enter the IP address for this machine. This should be in decimal and in dotted quad form (i.e., 192.168.10.253). The value of each three-digit number separated by dots should not exceed 255.

Subnet Mask - Subnet masks tell the network which subnet this machine belongs to. The value of each three-digit number separated by dots should not exceed 255.

Station MAC Address - MAC addresses are 6 two-digit hexadecimal numbers (Base 16, 0 ~ 9, A, B, C, D, E, F) separated by dots (i.e., 00.30.48.D0.D4.60).

Router IP Address - Enter the Gateway or Router address this machine will use (i.e., 192.168.10.1).

Router MAC Address - Enter the MAC address of the Router or Gateway (only if needed).



7-6 iSCSI

When sharing the iSCSI devices on this machine (iSCSI target), this section is used to enter the worldwide unique name of an iSCSI initiator. An iSCSI initiator application must be configured on the machine that will access the iSCSI drives in this machine.

Only IQN (iSCSI Qualified Names) names are accepted. Please research RFC 3720 and RFC 3721 at the Internet Engineering Task Force website (IETF -- www.ietf.org) for more information on iSCSI.

7-7 Boot Settings

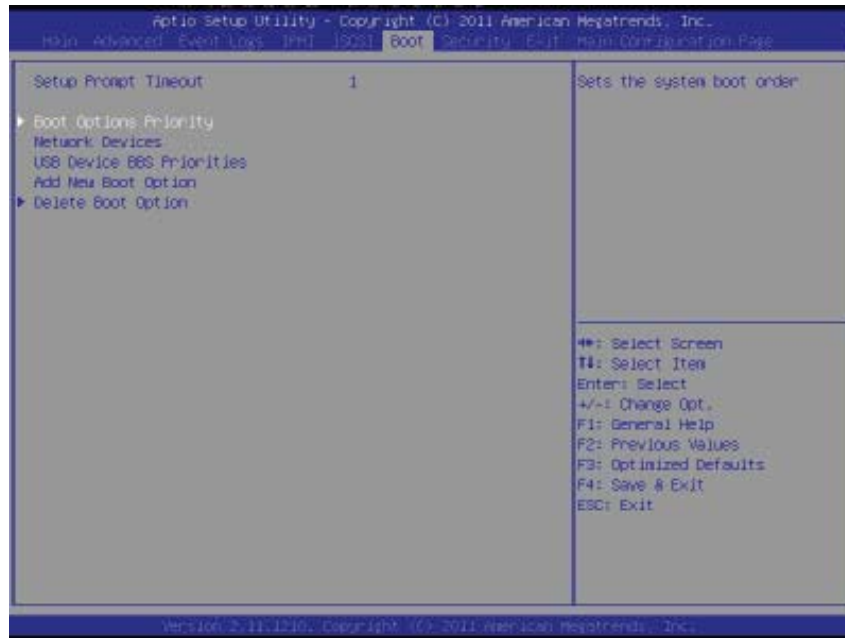

Use this feature to configure Boot Settings:

► Boot Options Priority

This feature allows the user to specify which devices are boot devices and the order of priority from which the systems boots from during startup.

Boot Option #1, Boot option #2, Boot Option #3, etc

The settings are **Built-in EFI Shell**, [any detected boot device] and Disabled.

Network Devices

This option sets the order of the legacy network devices detected by the motherboard..

► Delete Boot Option

This feature allows the user to delete a previously defined boot device from which the systems boots from during startup.

Boot Option #1, Boot option #2, Boot Option #3, etc

The settings are **Built-in EFI Shell**, and [any pre defined boot device]

7-8 Security Settings

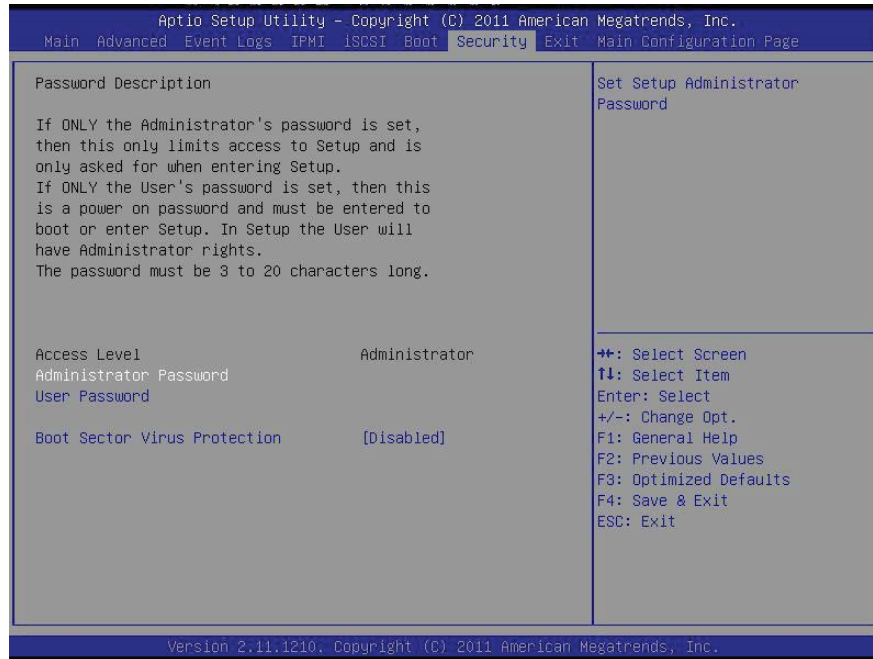

- If the Administrator password is defined ONLY - this controls access to the BIOS setup ONLY.
- If the User's password is defined ONLY - this password will need to be entered during each system startup or boot, and will also have Administrator rights in the setup.
- Passwords must be at least 3 and up to 20 characters long.

Administrator Password

Press Enter to create a new, or change an existing Administrator password.

User Password:

Press Enter to create a new, or change an existing User password.

Boot Sector Virus Protection

When Enabled, the BIOS displays a warning when any program (or virus) issues a Disk Format command or attempts to write to the boot sector of the hard disk drive. The options are Enabled and **Disabled**.

7-9 Exit Options

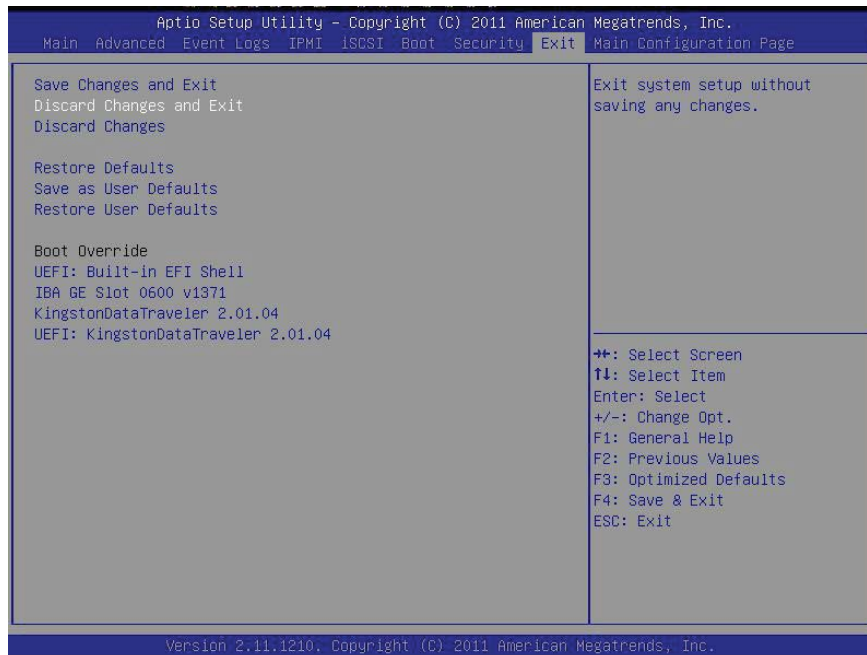

Select the Exit tab from the BIOS Setup Utility screen to enter the Exit BIOS Setup screen.

Save Changes and Exit

When you have completed the system configuration changes, select this option to leave the BIOS Setup Utility and reboot the computer, so the new system configuration parameters can take effect. Select Save Changes and Exit from the Exit menu and press <Enter>.

Discard Changes and Exit

Select this option to quit the BIOS Setup without making any permanent changes to the system configuration, and reboot the computer. Select Discard Changes and Exit from the Exit menu and press <Enter>.

Discard Changes

Select this option and press <Enter> to discard all the changes and return to the AMI BIOS Utility Program.

Restore Defaults

To set this feature, select Restore Defaults from the Exit menu and press <Enter>. These are factory settings designed for maximum system stability, but not for maximum performance.

Save As User Defaults

To set this feature, select Save as User Defaults from the Exit menu and press <Enter>. This enables the user to save any changes to the BIOS setup for future use.

Restore User Defaults

To set this feature, select Restore User Defaults from the Exit menu and press <Enter>. Use this feature to retrieve user-defined settings that were saved previously.

Boot Override

Set this feature to override a previously defined boot device. The available devices will be listed below.

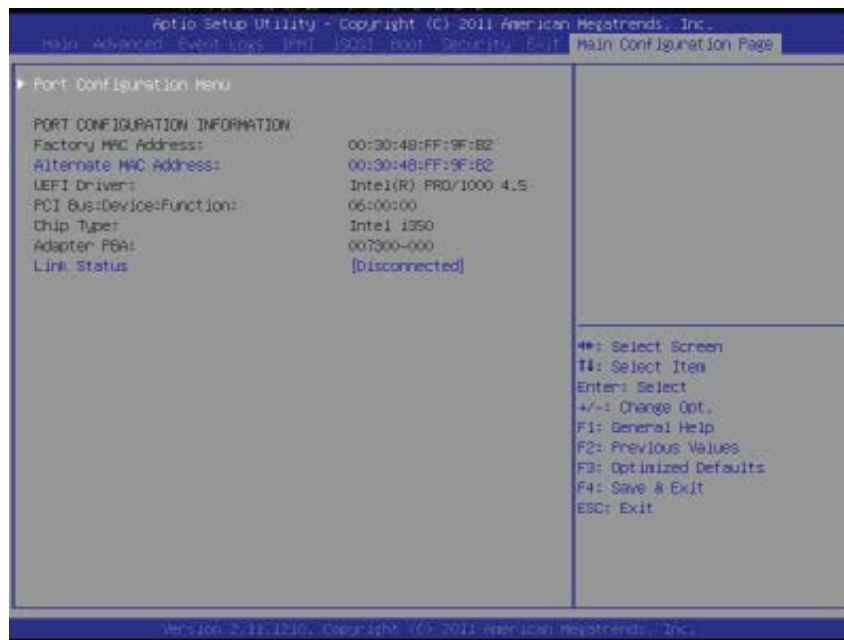

7-10 Main Configuration Page

►Port Configuration Menu

Use this feature to configure network-related options.

Preboot Option ROM

This option enables or disables the Option ROM for the current port. When disabled, the preboot driver can be loaded from this location. The options are **Enabled** and **Disabled**.

Link Speed

This feature changes the link speed and duplex mode for the current port. The options are **AutoNeg**, 10 Mbps Half, 10 Mbps Full, 100 Mbps Half and 100 Mbps Full.

Wake On LAN

This feature enables or disables the current port's Wake On LAN feature. When enabled, the system can be 'awaken' by sending a magic packet signal through the enabled LAN port. The options are **Enabled** and Disabled.

Port Configuration Information

This section displays information on the following devices:

Factory MAC address, Alternate MAC address, UEFI driver version, PCI Bus:Device:Function, Chip Type, Adapter PBA and Link Status.

Notes

Appendix A

POST Error Beep Codes

During the POST (Power-On Self-Test) routines, which are performed each time the system is powered on, errors may occur.

Non-fatal errors are those which, in most cases, allow the system to continue with bootup. The error messages normally appear on the screen.

Fatal errors will not allow the system to continue to bootup. If a fatal error occurs, you should consult with your system manufacturer for possible repairs.

These fatal errors are usually communicated through a series of audible beeps. The numbers on the fatal error list correspond to the number of beeps for the corresponding error.

POST Error Beep Codes		
Beep Code/LED	Error Message	Description
1 beep	Refresh	Circuits have been reset. (Ready to power up)
5 short beeps + 1 long beep	Memory error	No memory detected in the system
8 beeps	Display memory read/write error	Video adapter missing or with faulty memory
OH LED On	System OH	System Overheat

Notes

Appendix B

UEFI BIOS Recovery Instructions



Warning! Do not upgrade the BIOS unless your system has a BIOS-related issue. Flashing the wrong BIOS can cause irreparable damage to the system. In no event shall Supermicro be liable for direct, indirect, special, incidental, or consequential damages arising from a BIOS update. If you need to update the BIOS, do not shut down or reset the system while the BIOS is updating to avoid possible boot failure.

B-1 An Overview to the UEFI BIOS

The Unified Extensible Firmware Interface (UEFI) specification provides a software-based interface between the operating system and the platform firmware in the pre-boot environment. The UEFI specification supports an architecture-independent mechanism for add-on card initialization to allow the UEFI OS loader, which is stored in the add-on card, to boot up the system. UEFI offers a clean, hand-off control to a computer system at bootup.

B-2 Recovering the UEFI Main BIOS Block

An AMIBIOS flash chip consists of a boot sector block and a main BIOS code block (a main BIOS image). The boot sector block contains critical BIOS codes, including memory detection and recovery codes for the user to flash a new BIOS image if the original BIOS image is corrupted. When the system power is on, the boot sector codes execute first. Once it is completed, the main BIOS code will continue with system initialization and bootup.

Note: Follow the BIOS Recovery instructions below for BIOS recovery when the main BIOS block crashes. However, when the BIOS Boot sector crashes, you will need to send the motherboard back to Supermicro for RMA repair.

B-3 Recovery Using a USB-Attached Device

This feature allows the user to recover a BIOS image using a USB-attached device without additional utilities used. A USB flash device such as a USB Flash Drive, or a USB CD/DVD ROM/RW device can be used for this purpose. However, a USB Hard Disk drive cannot be used for BIOS recovery at this time.

To perform UEFI BIOS recovery using a USB-attached device, follow the instructions below.

1. Using a different machine, copy the "Super.ROM" binary image file into the disc Root "\\" Directory of a USB device or a writeable CD/DVD.

Note: If you cannot locate the "Super.ROM" file in your driver disk, visit our website at www.supermicro.com to download the BIOS image into a USB flash device and rename it to "Super ROM" for BIOS recovery use.

2. Insert the USB device that contains the new BIOS image ("Super.Rom") into your USB drive and power on the system
3. While powering on the system, keep pressing <Ctrl> and <Home> simultaneously on your PS2 or USB keyboard until your hear two short beeps. This may take from a few seconds to one minute.
4. After locating the new BIOS binary image, the system will enter the BIOS Recovery page as shown below.

Note: At this point, you may decide if you want to start with BIOS Recovery. If you decide to proceed with BIOS Recovery, follow the procedures below.

5. When the screen as shown above displays, using the arrow key, select the item- "Proceed with flash update" and press the <Enter> key. You will see the progress of BIOS Recovery as shown in the screen below.

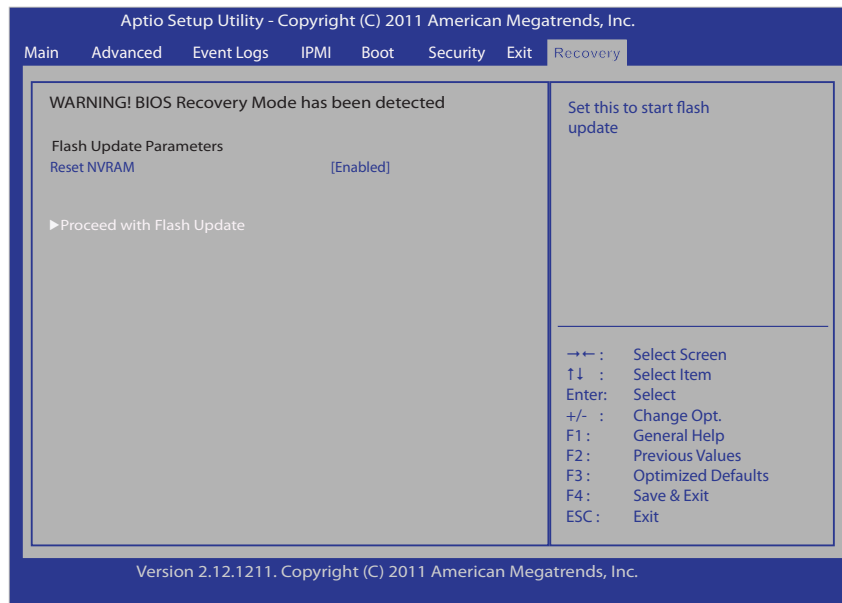

Note: Do not interrupt the process of BIOS flashing until it is completed.

6. After the process of BIOS Recovery is complete, press any key to reboot the system.

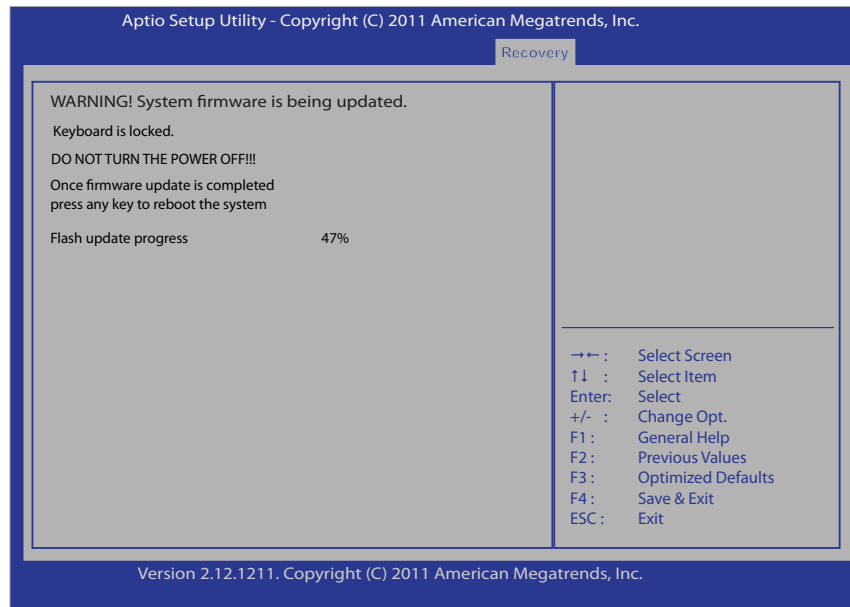

- Using a different system, extract the BIOS package into a bootable USB flash drive.

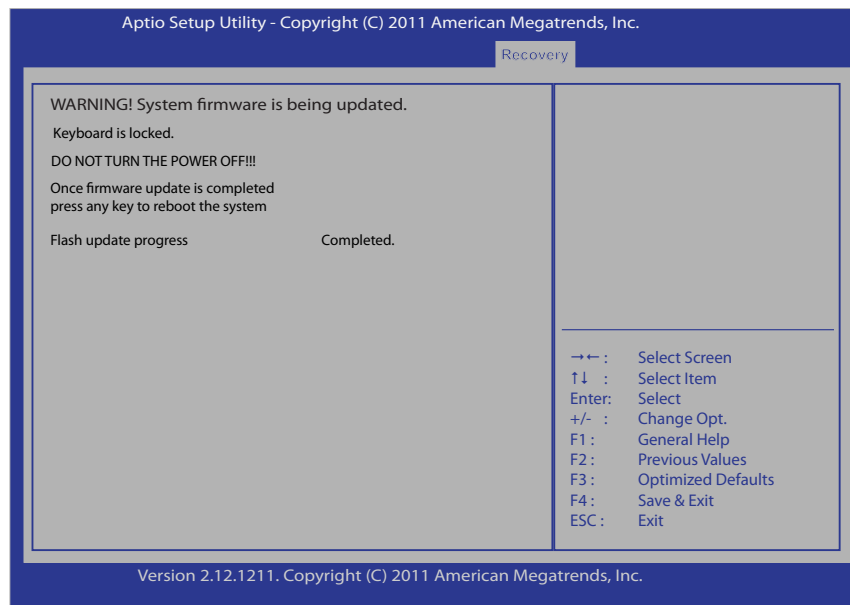

- When a DOS prompt appears, type AMI.BAT BIOSname.### at the prompt.

Note: *Do not interrupt* this process until BIOS flashing is completed.

- After seeing the message that BIOS update is completed, unplug the AC power cable to clear CMOS, and then plug in the AC power cable to power on the system.

10. Press continuously to enter the BIOS Setup utility.
11. Press <F3> to load default settings.
12. After loading default settings, press <F4> to save the settings and exit the BIOS Setup utility.

Appendix C

System Specifications

Processors

Single Intel® Xeon® E5-2600/E5-1600 Series processor in LGA 2011 socket

Note: Please refer to our web site for a complete listing of supported processors.

Chipset

Intel C600

BIOS

8 Mb SPI AMI® Flash

Memory Capacity

Eight DIMM sockets supporting up to 256 GB of DDR3-1600/1333/1066 ECC R/LRDIMMs or up to 64GB of ECC UDIMMs

See the memory section in Chapter 5 for details.

SATA Controller

Intel on-chip controller for two 6 Gb/sec SATA3 ports and four 3 Gb/sec SATA2 ports

SATA Drive Bays

One internal drive bay to house a SATA hard drive

Expansion Slots

Riser card for one PCI-E 3.0 x16 add-on card

Serverboard

X9SRi-F (ATX form factor)

Dimensions: 12 x 9.6 in (305 x 244 mm)

Chassis

SC512F-520B (Mini 1U Rackmount)

Dimensions: (WxHxD) 17.3 x 1.7 x 14.5 in. (439 x 43 x 368 mm)

Weight

Gross Weight: 18 lbs. (8.2 kg.)

System Cooling

Two 4-cm counter-rotating fans

System Input Requirements

AC Input Voltage: 100-240 VAC

Rated Input Current: 6.3A (115V) to 3.24A (230V)

Power Supply

Rated Output Power: 350W (Model# PWS-351-1H)

Rated Output Voltages: +3.3V (15A), +12_{ALL} (29A), +5V (18A), +5Vsb (3A)

Operating Environment

Operating Temperature: 10° to 35° C (50° to 95° F)

Non-operating Temperature: -40° to 70° C (-40° to 158° F)

Operating Relative Humidity: 8% to 90% (non-condensing)

Non-operating Relative Humidity: 5 to 95% (non-condensing)

Regulatory Compliance

Electromagnetic Emissions:

FCC Class A, EN 55022 Class A, EN 61000-3-2/-3-3, CISPR 22 Class A

Electromagnetic Immunity:

EN 55024/CISPR 24, (EN 61000-4-2, EN 61000-4-3, EN 61000-4-4,
EN 61000-4-5, EN 61000-4-6, EN 61000-4-8, EN 61000-4-11)

Safety:

EN 60950/IEC 60950-Compliant, UL Listed (USA), CUL Listed (Canada), TUV
Certified (Germany), CE Marking (Europe)

California Best Management Practices Regulations for Perchlorate Materials:

This Perchlorate warning applies only to products containing CR (Manganese
Dioxide) Lithium coin cells. "Perchlorate Material-special handling may apply.
See www.dtsc.ca.gov/hazardouswaste/perchlorate"

Disclaimer (continued from front)

The products sold by Supermicro are not intended for and will not be used in life support systems, medical equipment, nuclear facilities or systems, aircraft, aircraft devices, aircraft/emergency communication devices or other critical systems whose failure to perform be reasonably expected to result in significant injury or loss of life or catastrophic property damage. Accordingly, Supermicro disclaims any and all liability, and should buyer use or sell such products for use in such ultra-hazardous applications, it does so entirely at its own risk. Furthermore, buyer agrees to fully indemnify, defend and hold Supermicro harmless for and against any and all claims, demands, actions, litigation, and proceedings of any kind arising out of or related to such ultra-hazardous use or sale.

Notes