

SUPERO[®]

SUPERSERVER

1027GR-TQF
1027GR-TQFT

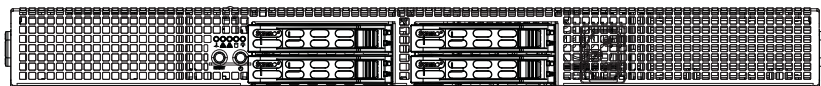

USER'S MANUAL

Revision 1.0

The information in this User's Manual has been carefully reviewed and is believed to be accurate. The vendor assumes no responsibility for any inaccuracies that may be contained in this document, makes no commitment to update or to keep current the information in this manual, or to notify any person or organization of the updates. **Please Note: For the most up-to-date version of this manual, please see our web site at www.supermicro.com.**

Super Micro Computer, Inc. ("Supermicro") reserves the right to make changes to the product described in this manual at any time and without notice. This product, including software and documentation, is the property of Supermicro and/or its licensors, and is supplied only under a license. Any use or reproduction of this product is not allowed, except as expressly permitted by the terms of said license.

IN NO EVENT WILL SUPERMICRO BE LIABLE FOR DIRECT, INDIRECT, SPECIAL, INCIDENTAL, SPECULATIVE OR CONSEQUENTIAL DAMAGES ARISING FROM THE USE OR INABILITY TO USE THIS PRODUCT OR DOCUMENTATION, EVEN IF ADVISED OF THE POSSIBILITY OF SUCH DAMAGES. IN PARTICULAR, SUPERMICRO SHALL NOT HAVE LIABILITY FOR ANY HARDWARE, SOFTWARE, OR DATA STORED OR USED WITH THE PRODUCT, INCLUDING THE COSTS OF REPAIRING, REPLACING, INTEGRATING, INSTALLING OR RECOVERING SUCH HARDWARE, SOFTWARE, OR DATA.

Any disputes arising between manufacturer and customer shall be governed by the laws of Santa Clara County in the State of California, USA. The State of California, County of Santa Clara shall be the exclusive venue for the resolution of any such disputes. Super Micro's total liability for all claims will not exceed the price paid for the hardware product.

FCC Statement: This equipment has been tested and found to comply with the limits for a Class A digital device pursuant to Part 15 of the FCC Rules. These limits are designed to provide reasonable protection against harmful interference when the equipment is operated in a commercial environment. This equipment generates, uses, and can radiate radio frequency energy and, if not installed and used in accordance with the manufacturer's instruction manual, may cause harmful interference with radio communications. Operation of this equipment in a residential area is likely to cause harmful interference, in which case you will be required to correct the interference at your own expense.

California Best Management Practices Regulations for Perchlorate Materials: This Perchlorate warning applies only to products containing CR (Manganese Dioxide) Lithium coin cells. "Perchlorate Material-special handling may apply. See www.dtsc.ca.gov/hazardouswaste/perchlorate"

WARNING: Handling of lead solder materials used in this product may expose you to lead, a chemical known to the State of California to cause birth defects and other reproductive harm.

Manual Revision 1.0
Release Date: August 10, 2012

Unless you request and receive written permission from Super Micro Computer, Inc., you may not copy any part of this document.

Information in this document is subject to change without notice. Other products and companies referred to herein are trademarks or registered trademarks of their respective companies or mark holders.

Copyright © 2012 by Super Micro Computer, Inc.
All rights reserved.
Printed in the United States of America

Preface

About This Manual

This manual is written for professional system integrators and PC technicians. It provides information for the installation and use of the SuperServer 1027GR-TQF/1027GR-TQFT. Installation and maintenance should be performed by experienced technicians only.

The SuperServer 1027GR-TQF/1027GR-TQFT is based on the SC118GQTS-1800GBP 1U server chassis and the Super X9DRG-HF/X9DRG-HTF serverboard. Please refer to our web site for an up-to-date list of supported operating systems, processors and memory. See Chapter 1 for a list of differences between the server models.

Manual Organization

Chapter 1: Introduction

The first chapter provides a checklist of the main components included with the server system and describes the main features of the Super X9DRG-HF/X9DRG-HTF serverboard and the SC118GQTS-1800GBP chassis.

Chapter 2: Server Installation

This chapter describes the steps necessary to install the system into a rack and check out the server configuration prior to powering up the system. If your server was ordered without the processor and memory components, this chapter will refer you to the appropriate sections of the manual for their installation.

Chapter 3: System Interface

Refer to this chapter for details on the system interface, which includes the functions and information provided by the control panel on the chassis as well as other LEDs located throughout the system.

Chapter 4: System Safety

You should thoroughly familiarize yourself with this chapter for a general overview of safety precautions that should be followed when installing and servicing the system.

Chapter 5: Advanced Serverboard Setup

Chapter 5 provides detailed information on the X9DRG-HF/X9DRG-HTF serverboard, including the locations and functions of connectors, headers and jumpers. Refer to this chapter when adding or removing processors or main memory and when reconfiguring the serverboard.

Chapter 6: Advanced Chassis Setup

Refer to Chapter 6 for detailed information on the SC118GQTS-1800GBP 1U rack-mount server chassis. You should follow the procedures given in this chapter when installing, removing or reconfiguring SATA or peripheral drives and when replacing system power supply units and cooling fans.

Chapter 7: BIOS

The BIOS chapter includes an introduction to BIOS and provides detailed information on running the CMOS Setup Utility.

Appendix A: BIOS Error Beep Codes

Appendix B: System Specifications

Notes

Table of Contents

Chapter 1 Introduction

1-1	Overview	1-1
1-2	Serverboard Features	1-2
	Processors	1-2
	Memory	1-2
	Serial ATA	1-2
	PCI Expansion Slots	1-2
	Onboard Controllers/Ports	1-2
	IPMI	1-2
1-3	Server Chassis Features	1-3
	System Power	1-3
	SATA Subsystem	1-3
	Front Control Panel	1-3
	Cooling System	1-3
1-4	GPU Subsystem	1-4
1-4	Contacting Supermicro	1-6

Chapter 2 Server Installation

2-1	Overview	2-1
2-2	Unpacking the System	2-1
2-3	Preparing for Setup	2-1
	Choosing a Setup Location	2-1
	Rack Precautions	2-2
	Server Precautions	2-2
	Rack Mounting Considerations	2-3
	Ambient Operating Temperature	2-3
	Reduced Airflow	2-3
	Mechanical Loading	2-3
	Circuit Overloading	2-3
	Reliable Ground	2-3
2-4	Installing the System into a Rack	2-4
	Identifying the Sections of the Rack Rails	2-4
	Installing the Inner Rail Extensions	2-5
	Assembling the Outer Rails	2-6
	Installing the Outer Rails onto the Rack	2-7
	Installing and Removing the Chassis From a Rack	2-8
	Installing the Server into a Telco Rack	2-9

Chapter 3 System Interface

3-1	Overview	3-1
3-2	Control Panel Buttons	3-1
	Reset	3-1
	Power	3-1
3-3	Control Panel LEDs	3-2
	Overheat/Fan Fail/UID LED	3-2
	NIC1	3-2
	NIC2	3-2
	HDD	3-3
	Power	3-3
3-4	Drive Carrier LEDs	3-3

Chapter 4 System Safety

4-1	Electrical Safety Precautions	4-1
4-2	General Safety Precautions	4-2
4-3	ESD Precautions	4-3
4-4	Operating Precautions	4-4

Chapter 5 Advanced Serverboard Setup

5-1	Handling the Serverboard	5-1
	Precautions	5-1
	Unpacking	5-2
5-2	Serverboard Installation	5-2
5-3	Connecting Cables	5-3
	Connecting Data Cables	5-3
	Connecting Power Cables	5-3
	Connecting the Control Panel	5-3
5-4	I/O Ports	5-4
5-5	Installing the Processor and Heatsink	5-5
	Installing an LGA 2011 Processor	5-5
	Installing a CPU Heatsink	5-8
	Memory Support	5-9
	Processor/DIMM Population Configurations	5-10
5-6	Expansion Cards	5-11
5-7	Serverboard Details	5-12
	X9DRG-HF/ X9DRG-HTF Quick Reference	5-13
5-8	Connector Definitions	5-15
5-9	Jumper Settings	5-21
5-10	Onboard Indicators	5-23

5-11	SATA Ports	5-24
5-12	Installing Software	5-25
	Supero Doctor III	5-26

Chapter 6 Advanced Chassis Setup

6-1	Static-Sensitive Devices	6-1
	Precautions	6-1
6-2	Control Panel	6-2
6-3	System Cooling	6-2
	System Fan Failure	6-3
	Installing the Air Shroud	6-5
	Installing Graphics (GPU) Cards	6-5
6-4	Drive Bay Installation/Removal	6-6
	Accessing the Drive Bays	6-6
	Hard Drive Installation	6-6
6-5	Power Supply	6-9

Chapter 7 BIOS

7-1	Introduction	7-1
	Starting BIOS Setup Utility	7-1
	How To Change the Configuration Data	7-2
	Starting the Setup Utility	7-2
7-2	Main Setup	7-2
7-3	Advanced Setup Configurations	7-4
7-4	Event Logs	7-25
7-5	IPMI	7-27
7-6	Boot	7-29
7-7	Security	7-30
7-8	Save & Exit	7-31

Appendix A BIOS Error Beep Codes

Appendix B System Specifications

Chapter 1

Introduction

1-1 Overview

The SuperServer 1027GR-TQF/1027GR-TQFT series is a GPU-optimized server comprised of two main subsystems: the SC118GQTS-1800GBP 1U server chassis and the X9DRG-HF/X9DRG-HTF serverboard. Please refer to our web site for information on operating systems that have been certified for use with the system (www.supermicro.com).

- Four 4-cm counter-rotating fans (FAN-0117L4)
- Eight 4-cm counter-rotating fans (FAN-0102L4)
- One air shroud (MCP-310-11802-0N)
- Two passive CPU heatsinks (SNK-P0047PS:CPU1 and SNK-P0047PSC:CPU2)
- Riser Cards
 - One RSC-R1UG-E16A-X9 for PCI-Express 3.0 x16 card, left front side
 - One RSC-R1UG-E16B-X9 for PCI-Express 3.0 x16 card, left rear side
 - One RSC-R1UG-E16AR-X9 for PCI-Express 3.0 x16 card, right front side
 - One RSC-R1UG-E16R-X9 for PCI-Express 3.0 x8 low-profile card, above serverboard
 - One RSC-R1UG-E16BR-X9 for PCI-Express 3.0 x16 card, right rear side
- Four power cables for GPU cards (3 pcs. CBL-0333L, 1 pc. CBL-0333L-01)
- SATA Accessories
 - One SAS backplane (BPN-SAS-118G-4)
 - Four hot-swap drive carriers (MCP-220-00047-0B)
 - Four SATA cables (CBL-0207L, CBL-0227L, 2 pcs. of CBL-0228L)
 - One SGPIO cable (CBL-0157L)
 - One backplane power ext. (CBL-0460L)
- One rail set (MCP-290-00054-0N)
- One Super Server 1027GR-TQF/1027GR-TQFT User's Manual

1-2 Serverboard Features

At the heart of the SuperServer 1027GR-TQF/1027GR-TQFT server is the X9DRG-HF/X9DRG-HTF, a dual processor serverboard based on the Intel C602 chipset. Below are the main features of the X9DRG-HF/X9DRG-HTF. (See Figure 1-1 for a block diagram of the chipset).

Processors

The X9DRG-HF/X9DRG-HTF supports two Intel Xeon E5-2600 series processors in LGA 2011 sockets (Socket R). Please refer to the serverboard description pages on our web site for a complete listing of supported processors (www.supermicro.com).

Memory

The X9DRG-HF/X9DRG-HTF has eight DIMM slots that can support up to 256 GB of registered ECC DDR3-1600/1333/1066/800 MHz RDIMMs. Modules of the same size and speed are recommended. See Chapter 5 for details.

Serial ATA

A SATA controller is integrated into the chipset to provide a 4-port SATA subsystem, which is RAID 0, 1, 5 and 10 supported. Two of these are SATA 3.0 ports and two are SATA 2.0 ports. The SATA drives are hot-swappable units.

Note: The operating system you use must have RAID support to enable the hot-swap capability and RAID function of the SATA drives.

PCI Expansion Slots

The X9DRG-HF/X9DRG-HTF has four PCI-Express 3.0 x16 slots to support four double-width GPU cards. Additional slots support one PCI-Express 3.0 x8 low-profile card with the use of a riser card (included).

Onboard Controllers/Ports

The color-coded I/O ports include a VGA (monitor) port, two USB 2.0 ports, two Gb Ethernet LAN ports (or two optional 10 Gb ports) and one dedicated IPMI LAN port.

IPMI

IPMI (Intelligent Platform Management Interface) is a hardware-level interface specification that provides remote access, monitoring and administration for Supermicro server platforms. IPMI allows server administrators to view a server's hardware

status remotely, receive an alarm automatically if a failure occurs, and power cycle a system that is non-responsive.

1-3 Server Chassis Features

System Power

The SC118GQTS-1800GBP features a high-efficiency 1800W power supply. The AC power cord should be removed from the system before servicing or replacing the power supply. See Chapter 6 for details.

SATA Subsystem

The SC118GQTS-1800GBP chassis includes four 2.5" drive bays, which may be used to house hot-swappable SATA drives. RAID 0, 1, 5 and 10 are supported (RAID 5 is not supported with Linux OS).

Front Control Panel

The control panel provides a system monitoring and control interface. LEDs indicate system power, HDD activity, network activity, system overheat, UID and power supply failure. A main power button and a system reset button are also included.

Cooling System

The SC118GQTS-1800GBP has an innovative cooling design that includes twelve 4-cm counter-rotating PWM (Pulse Width Modulated) fans. The power supply module also includes a cooling fan. All chassis and power supply fans operate continuously. These GPU servers include an air shroud (one for each GPU card) to further help cool the GPUs.

1-4 GPU Subsystem

The 1027GR-TQF/1027GR-TQFT server represents one of Supermicro's massively parallel processing multiple-GPU servers, with support for up to four GPUs. NVIDIA® Fermi™ GPUs place this system at the forefront of today's GPU computing solutions.

Please refer to the NVIDIA web site (www.nvidia.com) for details on Fermi GPUs.

Notes

The GPUs can be bundled with the system as follows:

1027GR-TQF-FM409: includes four NVIDIA Fermi M2090 GPUs.

1027GR-TQF-FM475: includes four NVIDIA Fermi M2075 GPUs

**Figure 1-1. Intel C602 Chipset:
System Block Diagram**

Note: This is a general block diagram. Please see Chapter 5 for details.

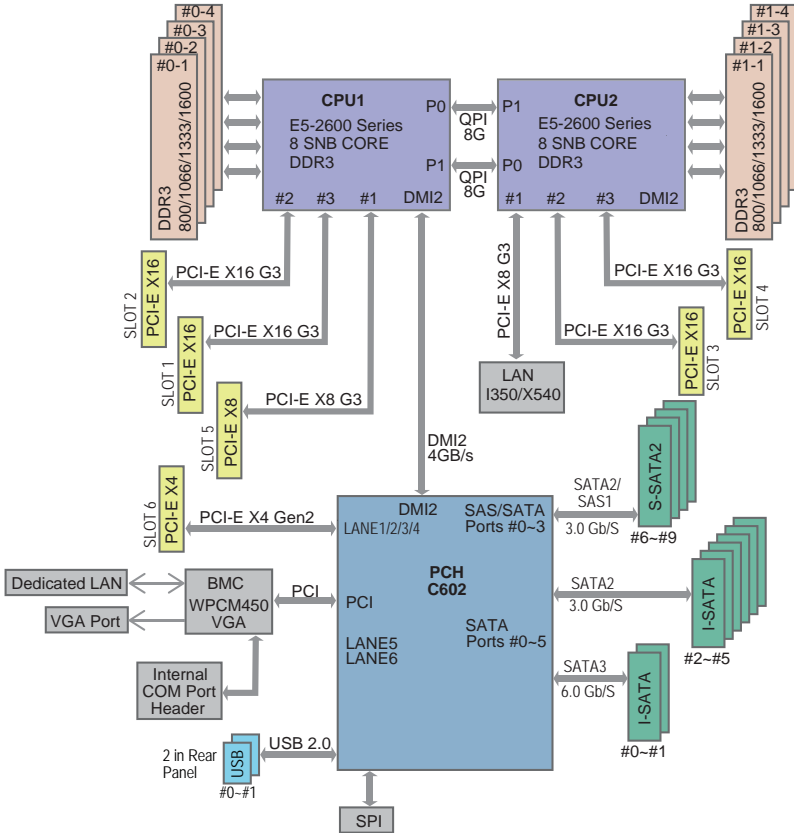

1-4 Contacting Supermicro

Headquarters

Address: Super Micro Computer, Inc.
980 Rock Ave.
San Jose, CA 95131 U.S.A.

Tel: +1 (408) 503-8000

Fax: +1 (408) 503-8008

Email: marketing@supermicro.com (General Information)
support@supermicro.com (Technical Support)

Web Site: www.supermicro.com

Europe

Address: Super Micro Computer B.V.
Het Sterrenbeeld 28, 5215 ML
's-Hertogenbosch, The Netherlands

Tel: +31 (0) 73-6400390

Fax: +31 (0) 73-6416525

Email: sales@supermicro.nl (General Information)
support@supermicro.nl (Technical Support)
rma@supermicro.nl (Customer Support)

Asia-Pacific

Address: Super Micro Computer, Inc.
4F, No. 232-1, Liancheng Rd.
Chung-Ho Dist., New Taipei City 235
Taiwan

Tel: +886-(2) 8226-3990

Fax: +886-(2) 8226-3991

Web Site: www.supermicro.com.tw

Technical Support:

Email: support@supermicro.com.tw

Tel: 886-2-8228-1366, ext.132 or 139

Chapter 2

Server Installation

2-1 Overview

This chapter provides a quick setup checklist to get your system up and running. Following these steps in the order given should enable you to have the system operational within a minimum amount of time. This quick setup assumes that your system has come to you with the processors and memory preinstalled. If your system is not already fully integrated with a serverboard, processors, system memory etc., please turn to the chapter or section noted in each step for details on installing specific components.

2-2 Unpacking the System

You should inspect the box the system was shipped in and note if it was damaged in any way. If the server itself shows damage you should file a damage claim with the carrier who delivered it.

Decide on a suitable location for the rack unit that will hold the server. It should be situated in a clean, dust-free area that is well ventilated. Avoid areas where heat, electrical noise and electromagnetic fields are generated. You will also need it placed near a grounded power outlet. Read the Rack and Server Precautions in the next section.

2-3 Preparing for Setup

The box the server was shipped in should include two sets of rail assemblies, two rail mounting brackets and the mounting screws you will need to install the system into the rack. Follow the steps in the order given to complete the installation process in a minimum amount of time. Please read this section in its entirety before you begin the installation procedure outlined in the sections that follow.

Choosing a Setup Location

- Leave enough clearance in front of the rack to enable you to open the front door completely (~25 inches) and approximately 30 inches of clearance in the back of the rack to allow for sufficient airflow and ease in servicing. This product is for installation only in a Restricted Access Location (dedicated equipment rooms, service closets and the like).

- This product is not suitable for use with visual display work place devices according to §2 of the the German Ordinance for Work with Visual Display Units.



Warnings and Precautions!



Rack Precautions

- Ensure that the leveling jacks on the bottom of the rack are fully extended to the floor with the full weight of the rack resting on them.
- In single rack installation, stabilizers should be attached to the rack. In multiple rack installations, the racks should be coupled together.
- Always make sure the rack is stable before extending a component from the rack.
- You should extend only one component at a time - extending two or more simultaneously may cause the rack to become unstable.
- Rack-mounted equipment should not be used as a shelf or work space.

Server Precautions

- Review the electrical and general safety precautions in Chapter 4.
- Determine the placement of each component in the rack *before* you install the rails.
- Install the heaviest server components on the bottom of the rack first, and then work up.
- Use a regulating uninterruptible power supply (UPS) to protect the server from power surges, voltage spikes and to keep your system operating in case of a power failure.
- Allow the hot plug SATA drives and power supply modules to cool before touching them.

- Always keep the rack's front door and all panels and components on the servers closed when not servicing to maintain proper cooling.

Rack Mounting Considerations

Ambient Operating Temperature

If installed in a closed or multi-unit rack assembly, the ambient operating temperature of the rack environment may be greater than the ambient temperature of the room. Therefore, consideration should be given to installing the equipment in an environment compatible with the manufacturer's maximum rated ambient temperature (T_{mra}).

Reduced Airflow

Equipment should be mounted into a rack so that the amount of airflow required for safe operation is not compromised.

Mechanical Loading

Equipment should be mounted into a rack so that a hazardous condition does not arise due to uneven mechanical loading.

Circuit Overloading

Consideration should be given to the connection of the equipment to the power supply circuitry and the effect that any possible overloading of circuits might have on overcurrent protection and power supply wiring. Appropriate consideration of equipment nameplate ratings should be used when addressing this concern.

Reliable Ground

A reliable ground must be maintained at all times. To ensure this, the rack itself should be grounded. Particular attention should be given to power supply connections other than the direct connections to the branch circuit (i.e. the use of power strips, etc.).

2-4 Installing the System into a Rack

This section provides information on installing the SC118GQ chassis into a rack unit with the rails provided. There are a variety of rack units on the market, which may mean that the assembly procedure will differ slightly. You should also refer to the installation instructions that came with the rack unit you are using.

Note: This rail will fit a rack between 26" and 33.5" deep.

Identifying the Sections of the Rack Rails

The chassis package includes two rack rail assemblies in the rack mounting kit. Each assembly consists of two sections: an inner fixed chassis rail that secures directly to the server chassis and an outer fixed rack rail that secures directly to the rack itself.

Figure 2-1. Identifying the Sections of the Rack Rails

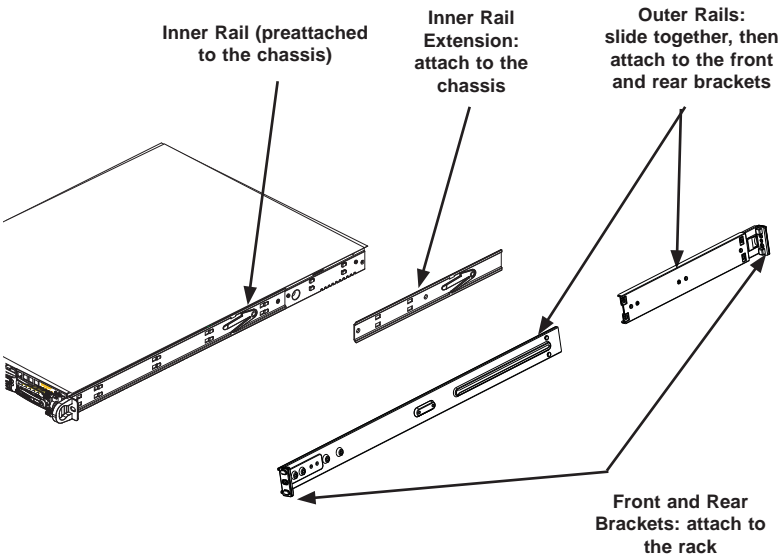

Installing the Inner Rail Extensions

The SC118GQ chassis includes a set of inner rack rails in two sections: inner rails (A) and inner rail extensions (B). The inner rails are preattached and do not interfere with normal use of the chassis if you decide not to install to a server rack. Attaching the inner rail extensions to the inner rails stabilizes the chassis within the rack.

Installing the Inner Rail Extensions

1. Place the inner rail extensions (B) over the preattached inner rails (A) which are attached to the side of the chassis. Align the hooks of the inner rail with the rail extension holes. Make sure the extension faces "outward" just like the inner rail.
2. Slide the extension toward the front of the chassis.
3. Secure the chassis with screws as illustrated.
4. Repeat steps 1-3 for the other inner rail extension.

Figure 2-2. Installing the Inner Rails

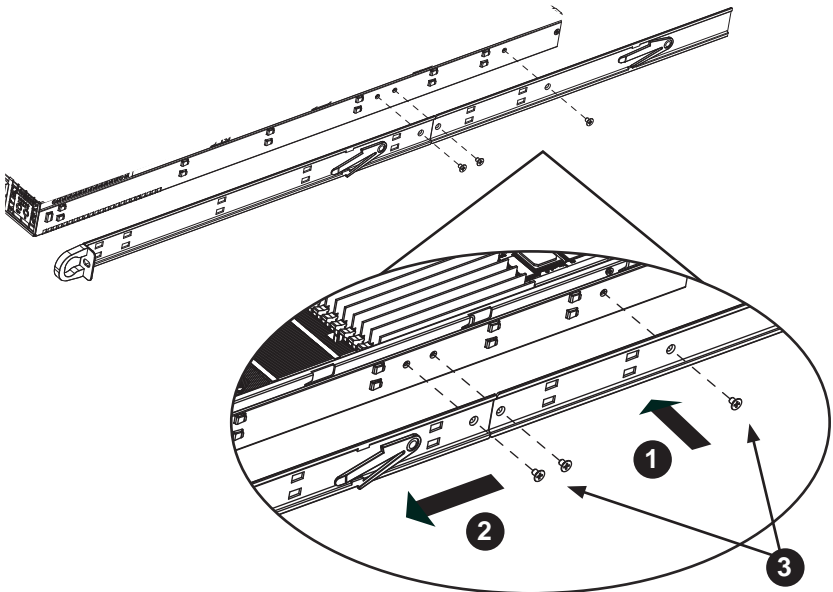

Assembling the Outer Rails

Each outer rail is in two sections that must be assembled before mounting on to the rack.

Assembling the Outer Rails

1. Identify the left and right outer rails by examining the ends, which bend outward.
2. Slide the front section of the outer rail (A), into the rear section of the outer rail (B).

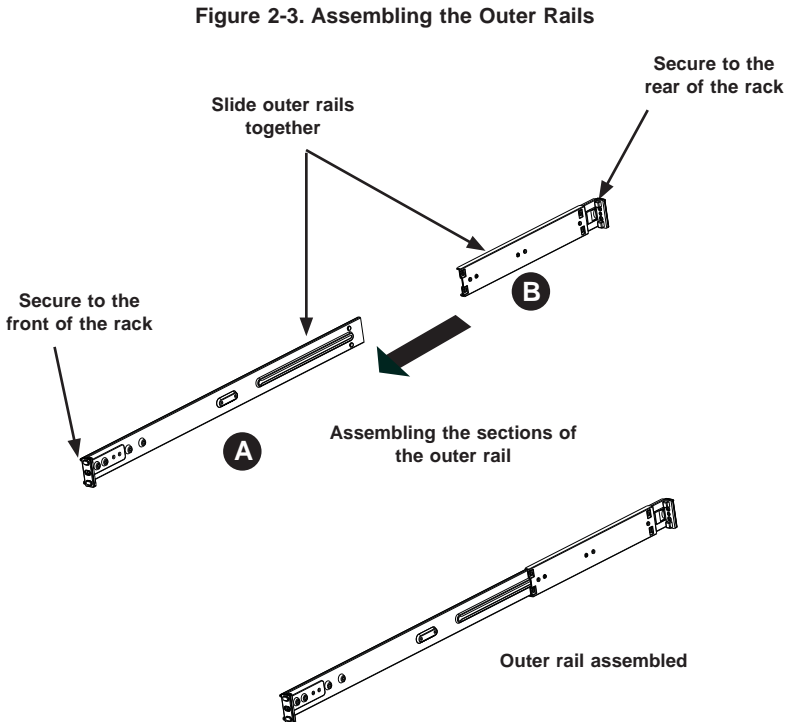

Installing the Outer Rails onto the Rack

Outer Rail Installation

1. Adjust the outer rails to the proper length so that the outer rail fits snugly within the rack.
2. Align the holes on the front of the outer rail, with the holes on the front of the rack (C) and secure with the screws provided.
3. Align the holes on the rear of the outer rail to the holes on the rack (D) and secure with the screws provided.
4. Repeat the procedure with the second outer rail assembly.

Figure 2-4. Installing the Outer Rails to the Rack

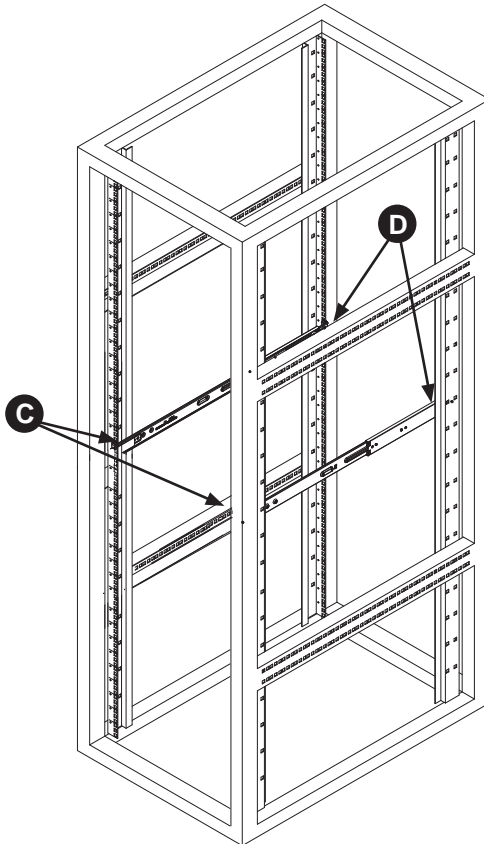

Installing and Removing the Chassis From a Rack

Installation into a Rack

1. Slide the inner rail extensions into the front of the outer rails.
2. Push the chassis backward into the rack until it clicks into the locked position.

Removing the Chassis From a Rack

1. Press the outer rail latch to release the chassis.
2. Carefully slide the chassis forward, off the outer rails and out of the chassis.

Figure 2-5: Chassis Installation

Figure 2-6: Chassis Removal

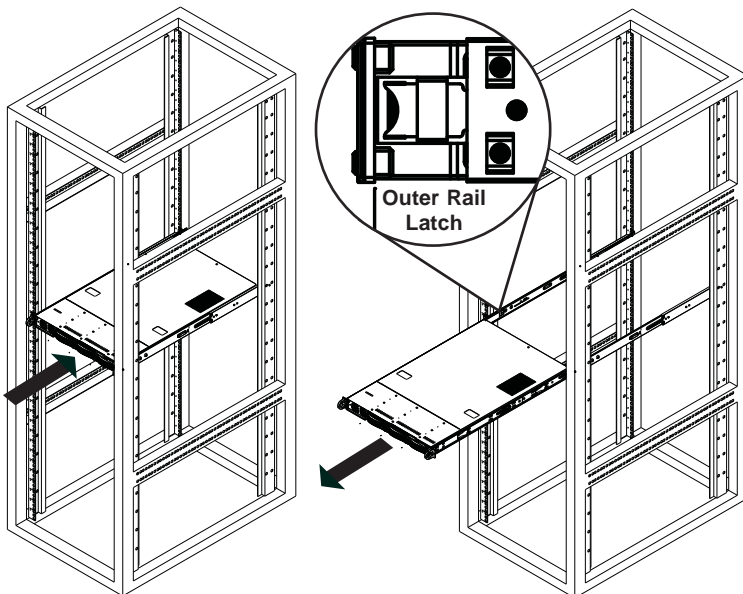

Installing the Server into a Telco Rack

Optional brackets are needed to install the server to a telco (open type) rack.

To install the server into a Telco type rack, use the two L-shaped brackets on either side of the chassis (four total). First, determine how far follow the server will extend out the front of the rack. Larger chassis should be positioned to balance the weight between front and back. If a bezel is included on your server, remove it. Then attach the two front brackets to each side of the chassis, then the two rear brackets positioned with just enough space to accommodate the width of the telco rack. Finish by sliding the chassis into the rack and tightening the brackets to the rack.

Figure 2-6. Installing the Server into a Telco Rack

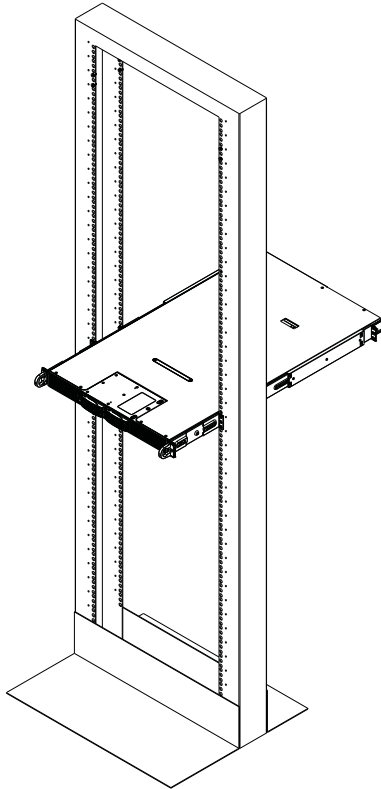

Notes

Chapter 3

System Interface

3-1 Overview

There are several LEDs on the control panel as well as others on the drive carriers to keep you constantly informed of the overall status of the system as well as the activity and health of specific components. There are also two buttons on the chassis control panel. This chapter explains the meanings of all LED indicators and the appropriate response you may need to take.

3-2 Control Panel Buttons

There are two push-buttons located on the front of the chassis: a reset button and a power on/off button.

RESET



Reset

Use the reset button to reboot the system.



Power

The main power button is used to apply or remove power from the power supply to the server system. Turning off system power with this button removes the main power but keeps standby power supplied to the system.

3-3 Control Panel LEDs

The two control panels are located on the front of the SC118GQTS chassis. Each control panel has six LEDs. These LEDs provide critical information related to different parts of the system. This section explains what each LED indicates when illuminated and any action that may be required..



Overheat/Fan Fail/UID LED

When this LED flashes it indicates a fan failure. When continuously on (not flashing) it indicates an overheat condition, which may be caused by cables obstructing the airflow in the system or the ambient room temperature being too warm. Check the routing of the cables and make sure that all fans are present and operating normally. Also check to make sure that the air shrouds are installed and that the top cover is on. Finally, verify that the heatsinks are installed properly.

This LED will remain flashing or on as long as the overheat condition exists. When used with a UID-compatible motherboard, the UID function is used to turn on or off the blue light function of the the LED. Once the blue light is activated through the system software, the unit can be easily located in very large racks and server banks.



NIC1

Indicates network activity on GLAN1 when flashing .



NIC2

Indicates network activity on GLAN2 when flashing .



HDD

This light indicates SATA and/or peripheral drive activity when flashing.



Power

Indicates power is being supplied to the system's power supply units. This LED should normally be illuminated when the system is operating.

3-4 Drive Carrier LEDs

- **Green:** Each hard drive carrier (for use with SATA drives) has a green LED. When illuminated, this green LED (on the front of the SATA drive carrier) indicates drive activity. A connection to the backplane enables this LED to blink on and off when that particular drive is being accessed. Please refer to Chapter 6 for instructions on replacing failed SATA drives.
- **Red:** The red LED to indicate a SATA drive failure. If one of the SATA drives fail, you should be notified by your system management software. Please refer to Chapter 6 for instructions on replacing failed SATA drives.

Notes

Chapter 4

System Safety

4-1 Electrical Safety Precautions



Note: power should always be disconnected before performing any service on the system.

Basic electrical safety precautions shall be followed to protect yourself from harm and the server from damage:

- Be aware of the locations of the power on/off switch on the chassis as well as the room's emergency power-off switch, disconnection switch or electrical outlet. If an electrical accident occurs, you can then quickly remove power from the system.
- Do not work alone when working with high voltage components.
- Power should always be disconnected from the system when removing or installing main system components, such as the serverboard, memory modules and floppy drive. When disconnecting power, you should first power down the system with the operating system first and then unplug the power cords of all the power supply units in the system.
- When working around exposed electrical circuits, another person who is familiar with the power-off controls should be nearby to switch off the power if necessary.
- Use only one hand when working with powered-on electrical equipment. This is to avoid making a complete circuit, which will cause electrical shock. Use extreme caution when using metal tools, which can easily damage any electrical components or circuit boards they come into contact with.
- Do not use mats designed to decrease static electrical discharge as protection from electrical shock. Instead, use rubber mats that have been specifically designed as electrical insulators.
- The power supply power cords must include a grounding plug and must be plugged into grounded electrical outlets.

- This product may be connected to an IT power system. In all cases, make sure that the unit is also reliably connected to Earth (ground).
- Serverboard Battery: **CAUTION** - There is a danger of explosion if the onboard battery is installed upside down, which will reverse its polarities (see Figure 4-1). This battery must be replaced only with the same or an equivalent type recommended by the manufacturer (CR2032). Dispose of used batteries according to the manufacturer's instructions.
- DVD-ROM Laser: **CAUTION** - this server may have come equipped with a DVD-ROM drive. To prevent direct exposure to the laser beam and hazardous radiation exposure, do not open the enclosure or use the unit in any unconventional way.
- Mainboard replaceable soldered-in fuses: Self-resetting PTC (Positive Temperature Coefficient) fuses on the mainboard must be replaced by trained service technicians only. The new fuse must be the same or equivalent as the one replaced. Contact technical support for details and support.

4-2 General Safety Precautions



Follow these rules to ensure general safety:

- Keep the area around the server clean and free of clutter.
- The server weighs approximately 37 lbs. (16.8 kg) when fully loaded. When lifting the system, two people at either end should lift slowly with their feet spread out to distribute the weight. Always keep your back straight and lift with your legs.
- Place the chassis top cover and any system components that have been removed away from the system or on a table so that they won't accidentally be stepped on.
- While working on the system, do not wear loose clothing such as neckties and unbuttoned shirt sleeves, which can come into contact with electrical circuits or be pulled into a cooling fan.

- Remove any jewelry or metal objects from your body, which are excellent metal conductors that can create short circuits and harm you if they come into contact with printed circuit boards or areas where power is present.
- After accessing the inside of the system, close the system back up and secure it to the rack unit with the retention screws after ensuring that all connections have been made.

4-3 ESD Precautions



Electrostatic Discharge (ESD) is generated by two objects with different electrical charges coming into contact with each other. An electrical discharge is created to neutralize this difference, which can damage electronic components and printed circuit boards. The following measures are generally sufficient to neutralize this difference before contact is made to protect your equipment from ESD:

- Use a grounded wrist strap designed to prevent static discharge.
- Keep all components and printed circuit boards (PCBs) in their antistatic bags until ready for use.
- Touch a grounded metal object before removing the board from the antistatic bag.
- Do not let components or PCBs come into contact with your clothing, which may retain a charge even if you are wearing a wrist strap.
- Handle a board by its edges only; do not touch its components, peripheral chips, memory modules or contacts.
- When handling chips or modules, avoid touching their pins.
- Put the serverboard and peripherals back into their antistatic bags when not in use.
- For grounding purposes, make sure your computer chassis provides excellent conductivity between the power supply, the case, the mounting fasteners and the serverboard.

4-4 Operating Precautions



Care must be taken to assure that the chassis cover is in place when the system is operating to ensure proper cooling. Out of warranty damage to the system can occur if this practice is not strictly followed.

Figure 4-1. Installing the Onboard Battery

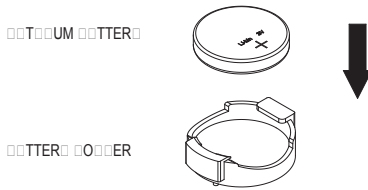

Please handle used batteries carefully. Do not damage the battery in any way; a damaged battery may release hazardous materials into the environment. Do not discard a used battery in the garbage or a public landfill. Please comply with the regulations set up by your local hazardous waste management agency to dispose of your used battery properly.

Chapter 5

Advanced Serverboard Setup

This chapter covers the steps required to connect the data and power cables and install add-on cards. All serverboard jumpers and connections are also described. A layout and quick reference chart are included in this chapter for your reference. Remember to completely close the chassis when you have finished working with the serverboard to better cool and protect the system.

5-1 Handling the Serverboard

Electrostatic Discharge (ESD) can damage electronic components. To prevent damage to any printed circuit boards (PCBs), it is important to handle them very carefully (see previous chapter). To prevent the serverboard from bending, keep one hand under the center of the board to support it when handling. The following measures are generally sufficient to protect your equipment from electric static discharge.

Precautions

- Use a grounded wrist strap designed to prevent Electrostatic Discharge (ESD).
- Touch a grounded metal object before removing any board from its antistatic bag.
- Handle a board by its edges only; do not touch its components, peripheral chips, memory modules or gold contacts.
- When handling chips or modules, avoid touching their pins.
- Put the serverboard, add-on cards and peripherals back into their antistatic bags when not in use.
- For grounding purposes, make sure your computer chassis provides excellent conductivity between the power supply, the case, the mounting fasteners and the serverboard.

Unpacking

The serverboard is shipped in antistatic packaging to avoid electrical static discharge. When unpacking the board, make sure the person handling it is static protected.

5-2 Serverboard Installation

This section explains the first step of physically mounting the X9DRG-HF/X9DRG-HTF into the SC118GQ chassis. Following the steps in the order given will eliminate the most common problems encountered in such an installation. To remove the serverboard, follow the procedure in reverse order.

Installing to the Chassis

1. Access the inside of the system by removing the screws from the back lip of the top cover of the chassis, then pull the cover off.
2. Make sure that the I/O ports on the serverboard align properly with their respective holes in the I/O shield at the back of the chassis.
3. Carefully mount the serverboard to the serverboard tray by aligning the board holes with the raised metal standoffs that are visible in the chassis.
4. Insert screws into all the mounting holes on your serverboard that line up with the standoffs and tighten until snug (if you screw them in too tight, you might strip the threads). Metal screws provide an electrical contact to the serverboard ground to provide a continuous ground for the system.
5. Install the processors and make all necessary cable connections, as described in the sections that follow.

Warning: To avoid damaging the serverboard and its components, do not apply any force greater than 8 lbs. per square inch when installing a screw into a mounting hole.

5-3 Connecting Cables

Now that the serverboard is installed, the next step is to connect the cables to the board. These include the data (ribbon) cables for the peripherals and control panel and the power cables.

Connecting Data Cables

The ribbon cables used to transfer data from the peripheral devices have been carefully routed to prevent them from blocking the flow of cooling air that moves through the system from front to back. If you need to disconnect any of these cables, you should take care to keep them routed as they were originally after reconnecting them (make sure the red wires connect to the pin 1 locations). The following data cables (with their locations noted) should be connected. (See the layout on page 5-12 for connector locations.)

- SATA drive data cables (I-SATA0 ~ 3)
- SATA sideband cable (T-SGPIO ~ 1)
- Control Panel cable (JF1)
- GPU power cables (JPW3, JPW7 and JPW11)
- SATA backplane power cable (JPW5)

Important! Make sure the the cables do not come into contact with the fans.

Connecting Power Cables

The X9DRG-HF/X9DRG-HTF has three proprietary power supply connectors (JPW1, JPW2 and JPW9) for connection to the ATX power supply. See Section 5-9 for power connector pin definitions.

Connecting the Control Panel

JF1 contains header pins for various front control panel connectors. See Figure 5-1 for the pin locations of the various front control panel buttons and LED indicators.

All JF1 wires have been bundled into a single ribbon cable to simplify this connection. Make sure the red wire plugs into pin 1 as marked on the board. The other end connects to the Control Panel PCB board, located just behind the system status LEDs on the chassis. See Chapter 5 for details and pin descriptions.

Figure 5-1. Control Panel Header Pins

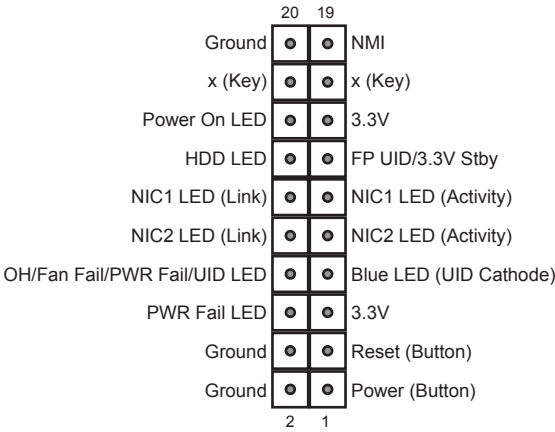

5-4 I/O Ports

The I/O ports are color coded in conformance with the PC 99 specification. See Figure 5-2 below for the colors and locations of the various I/O ports.

Figure 5-2. I/O Ports

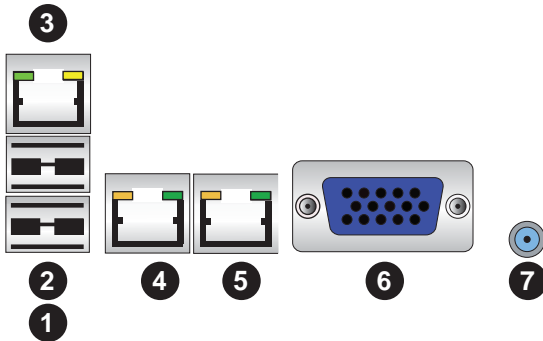

IO Ports	
1. USB Port 0	5. LAN Port 2
2. USB Port 1	6. VGA Port
3. IPMI Dedicated LAN	7. UID Switch
4. LAN Port 1	

Note: the LAN ports on the X9DRG-HTF are 10 Gb ports.

5-5 Installing the Processor and Heatsink



Avoid placing direct pressure to the top of the processor package. Always remove the power cord first before adding, removing or changing any hardware components.

Notes:

- Always connect the power cord last and always remove it before adding, removing or changing any hardware components. Make sure that you install the processor into the CPU socket before you install the CPU heatsink.
- If you buy a CPU separately, make sure that you use an Intel-certified multi-directional heatsink only.
- Make sure to install the serverboard into the chassis before you install the CPU heatsinks.
- When receiving a serverboard without a processor pre-installed, make sure that the plastic CPU socket cap is in place and none of the socket pins are bent; otherwise, contact your retailer immediately.
- Refer to the Supermicro web site for updates on CPU support.

Installing an LGA 2011 Processor

Follow the procedure below, beginning with the CPU1 socket.

1. There are two levers on the LGA 2011 socket. First press and release the load lever labeled 'Open 1st'.
2. Press the second load lever labeled 'Close 1st' to release the load plate from its locked position.

Press down on the lever labeled 'Close 1st'

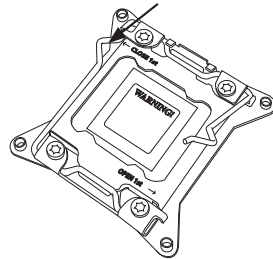

Pull lever away from the socket

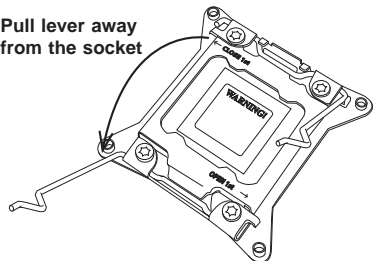

3. With the lever labeled 'Close 1st' fully retracted, gently push down on the 'Open 1st' lever to open the load plate. Lift the load plate to open it completely.
4. Using your thumb and the index finger, remove the 'WARNING' plastic cap from the socket.
5. Use your thumb and index finger to hold the CPU by its edges. Align the CPU keys, which are semi-circle cutouts, against the socket keys.
6. Once they are aligned, carefully lower the CPU straight down into the socket. (Do not drop the CPU on the socket. Do not move the CPU horizontally or vertically and do not rub the CPU against any pins of the socket, which may damage the CPU or the socket.)

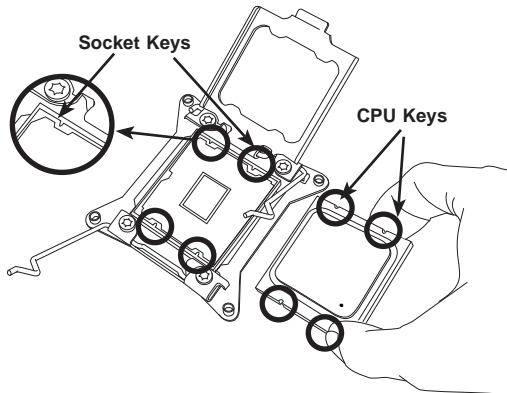
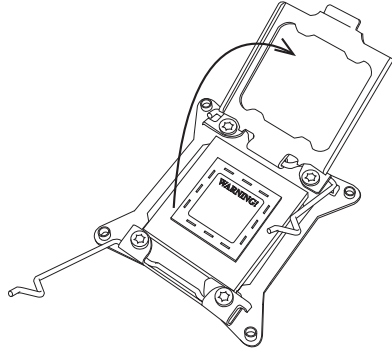
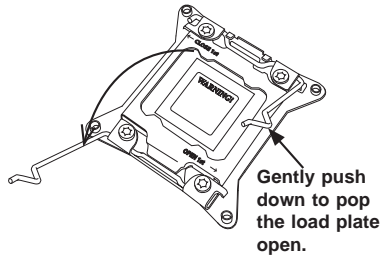



Warning: You can only install the CPU to the socket in one direction. Make sure that the CPU is properly inserted into the socket before closing the load plate. If it doesn't close properly, do not force it as it may damage your CPU. Instead, open the load plate again and double-check that the CPU is aligned properly.

7. With the CPU in the socket, inspect the four corners of the CPU to make sure that they are flush with the socket.
8. Close the load plate. Lock the lever labeled 'Close 1st', then lock the lever labeled 'Open 1st'. Use your thumb to gently push the load levers down until the lever locks.
9. Repeat the procedure to install a second processor in the CPU2 socket if desired.

Note: the PCI-E slots are controlled by the presence of a CPU. Slots will not be functional if the CPU that controls them is not installed. See Section 5-7 for details.

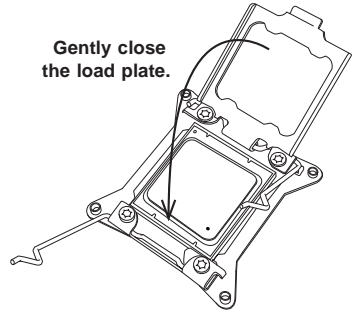

Push down and lock the level labeled 'Close 1st'.

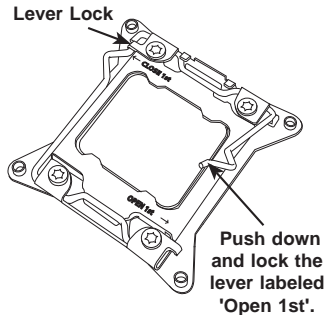
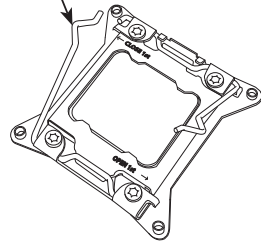

Installing a CPU Heatsink

1. Remove power from the system and unplug the AC power cord from the power supply.
2. Do not apply any thermal grease to the heatsink or the CPU die; the required amount has already been applied.
3. Place the heatsink on top of the CPU so that the four mounting holes are aligned with those on the (preinstalled) heatsink retention mechanism.
4. Screw in two diagonal screws until just snug. Do not fully tighten the screws or you may damage the CPU.)
5. Add the two remaining screws then finish the installation by fully tightening all four screws.

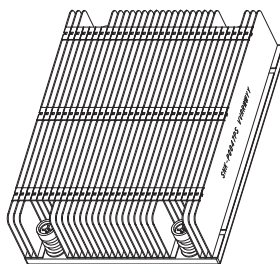

SNK-P0047PS (CPU1)

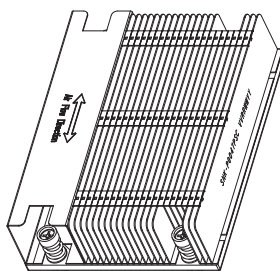

SNK-P0047PSC (CPU2)

Removing the Heatsink

1. Unscrew and remove the heatsink screws from the serverboard in the sequence as show in the picture above.
2. Hold the heatsink and gently wriggle the heatsink to loosen it from the CPU. (Do not use excessive force when wriggling the heatsink!!)
3. Once the heatsink is loose, remove it from the CPU socket.
4. Clean the surface of the CPU and the heatsink to get rid of the old thermal grease. Reapply the proper amount of thermal grease on the surface before you re-install a heatsink.

Note: see Chapter 6 for details on installing the air shroud.

5-6 Installing Memory



CAUTION! Exercise extreme care when installing or removing DIMM modules to prevent any possible damage.

Memory Support

The X9DRG-HF/X9DRG-HTF supports up to 256 GB of registered ECC DDR3-1600/1333/1066/800 MHz RDIMMs or 64 GB of ECC/non-ECC UDIMMs in 8 DIMM slots. See the following tables for memory installation.

Notes: Memory speed support is dependent on the type of CPU used on the board.

Installing Memory Modules

1. Insert the desired number of DIMMs into the memory slots, starting with P1-DIMM 1A. For best memory performance, please install memory modules of the same type and same speed on the memory slots as indicated on the tables below.
2. Insert each DIMM module vertically into its slot. Pay attention to the notch along the bottom of the module to avoid installing incorrectly (see Figure 5-4).
3. Gently press down on the DIMM module until it snaps into place in the slot. Repeat for all modules.

Figure 5-3. DIMM Installation

To Install: Insert module vertically and press down until it snaps into place. Pay attention to the alignment notch at the bottom.

To Remove: Use your thumbs to gently push the release tabs near both ends of the module. This should release it from the slot.

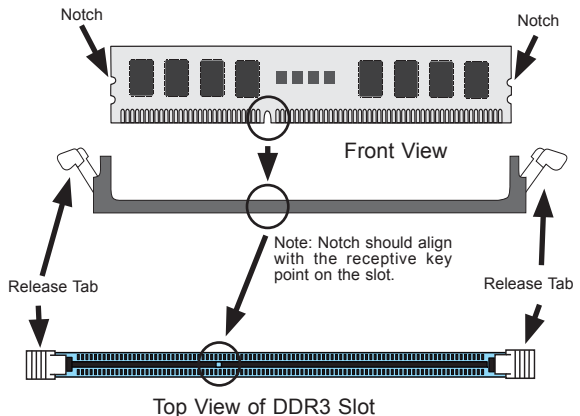

Processor/DIMM Population Configurations

For memory to work properly, follow the tables below for memory installation.

- For memory to operate properly, please install DIMMs in pairs (have an even number of DIMMs installed).
- All channels in a system will run at the fastest common frequency.

Processors and their Corresponding DIMMs				
CPU#	Corresponding DIMM Modules			
CPU 1	P1-A1	P1-B1	P1-C1	P1-D1
CPU2	P2-E1	P2-F1	P2-G1	P2-H1

Populating DIMMs	
Number of CPUs+DIMMs	CPU and DIMM Population Configuration Table (For memory to work proper, please install DIMMs in pairs)
1 CPU & 2 DIMMs	CPU1 P1-A1/P1-B1
1 CPU & 4 DIMMs	CPU1 P1-A1/P1-B1, P1-C1/P1-D1
2 CPUs & 4 DIMMs	CPU1 + CPU2 P1-A1/P1-B1, P2-E1/P2-F1
2 CPUs & 6 DIMMs	CPU1 + CPU2 P1-A1/P1-B1/P1-C1/P1-D1, P2-E1/P2-F1
2 CPUs & 8 DIMMs	CPU1 + CPU2 P1-A1/P1-B1/P1-C1/P1-D1, P2-E1/P2-F1/P2-G1/P2-H1

RDIMM Support POR				
DIMM Slots per Channel	DIMMs Populated per DDR Channel	RDIMM Type (RDIMM = Registered DIMMs)	POR Speeds (in MHz)	Ranks per DIMM (Any Combination)
1	1	Reg. ECC DDR3	800/1066/1333/1600	SR, DR, or QR
2	1	Reg. ECC DDR3	800/1066/1333/1600	SR, DR, or QR
2	2	Reg. ECC DDR3	800/1066/1333/1600	Mixing SR, DR, QR

Population Rules:

1. Any combination of x4 and x8 RDIMMs with 1 Gb or 2 Gb DRAM density are supported.
2. Populate DIMMs starting with DIMM A1.
3. When mixing QR with SR or DR on the same DDR channel, put the QR in DIMMA1 first.

5-6 Expansion Cards

In addition to offering support for four GPU cards, the 1027GR-TQF/1027GR-TQFT supports one low-profile PCI-Express 3.0 x8 expansion card (in x16 slot). A riser card is required to support expansion cards.

Refer to Chapter 6 for instructions on installing an expansion card in the system..

5-7 Serverboard Details

Figure 5-5. X9DRG-HF/ X9DRG-HTF Layout

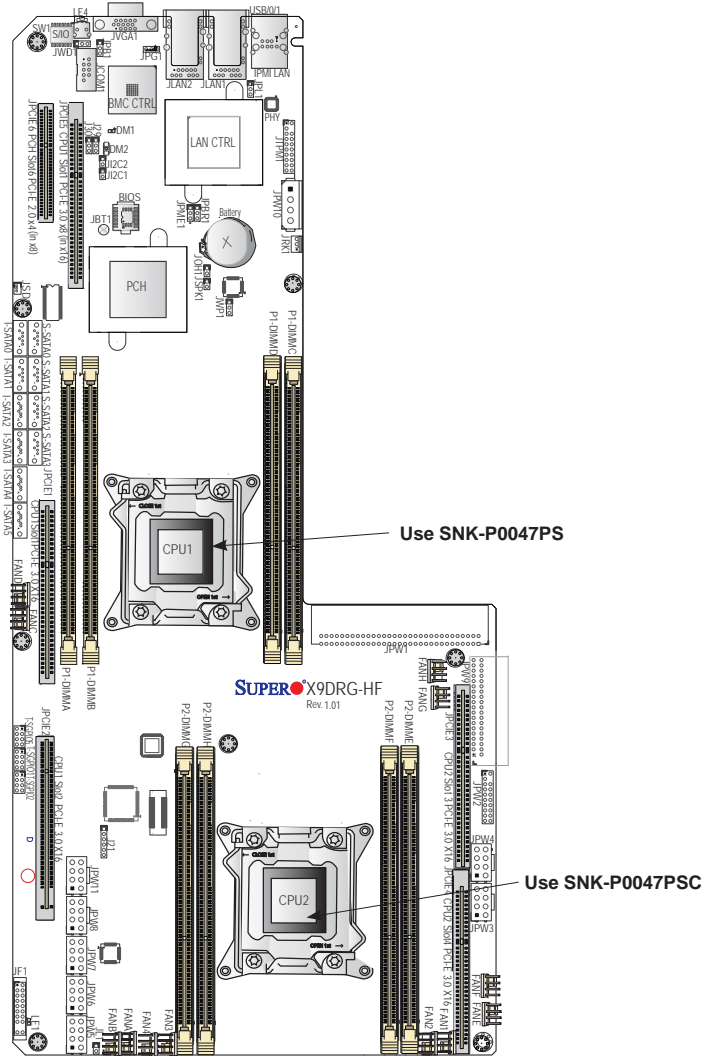

Notes

Jumpers not indicated are for test purposes only.

"■" indicates the location of Pin 1.

The X9DRG-HTF supports two X540-based 10G LAN ports, the X9DRG-HF supports two I350-based 1G LAN ports.

X9DRG-HF/ X9DRG-HTF Quick Reference

Jumper	Description	Default Setting
JBT1	Clear CMOS	See Section 5-9
JBR1	ME Recovery	Pins 2-3 (Normal)
JPB1	BMC Enable/Disable	Pins 1-2 (Enabled)
JPG1	VGA Enable/Disable	Pins 1-2 (Enabled)
JPL1	LAN1/LAN2 Enable/Disable	Pins 1-2 (Enabled)
JPME1	Manufacture Mode	Pins 1-2 (Normal)
JWD	Watch Dog Timer Enable/Disable	Pins 1-2 (Reset)
JWP1	Write-Protect Enable/Disable	Pins 1-2 (Enabled)

Connector	Description
Battery	Onboard Battery
FAN1 - FAN4	CPU Fans
FANA - FANH	GPU Fans
JCOM1	COM Header for Front Chassis Access
JF1	Control Panel Header
JL1	Chassis Intrusion Header
JOH1	Overheat LED Indicator
JI ² C1/JI ² C2	Power Supply SMBbus I ² C Header
JPW1	Proprietary 62-pin Power Connector
JPW2	Proprietary 20-pin Power Connector
JPW3-8, JPW11	12V 8-pin Power Connectors
JPW9	Proprietary 38-pin Power Connector
JPW10	5V 4-pin Power Connector
JSD1	Power Fail Header
JSPK1	Onboard Speaker Header
JTPM1	TPM (Trusted Platform Module)/Port 80 Header
JRK1	SATA RAID Key Header
JVGA1	Backpanel VGA Port
LAN1/LAN2	LAN Ports 1/2 (1 GB on X9DRG-HF, 10 GB on X9DRG-HTF)
(IPMI) LAN	IPMI Dedicated LAN

I-SATA 0~5	SATA 3.0 (I-SATA 0/1) and SATA 2.0 Ports (I-SATA 2~5)
------------	---

S-SATA 0~3	SATA 2.0 Ports (S-SATA 0~3)
------------	-----------------------------

PCI Slot 1/Slot 2	PCI-E 3.0 x16 Slots (Available when CPU1 is populated)
-------------------	--

PCI Slot 5	PCI-E 3.0 x8 in x16 Slot (Available when CPU1 is populated)
------------	---

PCI Slot 3/Slot 4	PCI-E 3.0 x16 Slots (Available when CPU2 is populated)
-------------------	--

(PCH) PCI Slot 6	PCI-E 2.0 x4 in x8 Slot (Available when CPU2 is populated)
------------------	--

SW1	UID Switch
-----	------------

T-SGPIO 1/2/S	Serial Link General Purpose I/O Headers
---------------	---

USB 0/1	Back Panel USB Ports
---------	----------------------

LED	Description	State/Status
-----	-------------	--------------

DM1	BMC Heartbeat LED	Green: BMC Normal
-----	-------------------	-------------------

LE1	Standby PWR LED	Green: SB Power On
-----	-----------------	--------------------

LE4	UID Switch LED	
-----	----------------	--

Notes:

PCI-E Slot 1, Slot 2 and Slot 5 are controlled by CPU1 and are only available when a processor is installed in CPU Socket 1. PCI-E Slot 3, Slot 4 and Slot 6 are controlled by CPU2 and are available only when a processor is installed in CPU Socket 2.

To provide adequate power supply to the system, be sure to connect all onboard power connectors to the power supply.

5-8 Connector Definitions

Power Connectors

Three SMC-proprietary power connectors are located at JPW1, JPW2 and JPW9 to provide main power to the serverboard. Seven 12V, 8-pin power connectors, located at JPW3-8 and JPW11, are used for SATA devices and GPU cards (JPW5 is for the backplane). An additional 4-pin auxiliary connector is located at JPW10. Connect these power headers as described below.

12V 8-pin Power Connector Pin Definitions	
Pins	Definition
1 through 3	+12V
4 through 8	Ground

5V 4-pin Power Connector Pin Definitions	
Pins	Definition
1	+12V
2-3	Ground
4	+5V

JPW1: 62-pin SMC-Proprietary (Required)

JPW2: 20-pin SMC-Proprietary (Required)

JPW9: 38-pin SMC-Proprietary (Required)

JPW5: 12V 8-pin for HDD backplane (Required)

JPW3, 4, 6, 7, 8, 11: 12V 8-pin for GPU power

JPW10: 5V 4-pin Auxiliary

Power Button Connector

The PW_ON connector is on pins 1 and 2 of JF1. Momentarily contacting both pins will power on/off the system. This button can also be configured to function as a suspend button (with a setting in the BIOS, see Chapter 7). To turn off the power when set to suspend mode, press the button for at least 4 seconds. Refer to the table on the right for pin definitions. This header should be connected to the chassis power button. See the table on the right for pin definitions.

Power Button Pin Definitions (JF1)	
Pin#	Definition
1	Power Button
2	Ground

Reset Connector

The reset connector is located on pins 3 and 4 of JF1 and attaches to the reset switch on the computer chassis. See the table on the right for pin definitions.

Reset Button Pin Definitions (JF1)	
Pin#	Definition
3	Reset
4	Ground

Power Fail LED

The Power Fail LED connection is located on pins 5 and 6 of JF1. Refer to the table on the right for pin definitions.

PWR Fail LED Pin Definitions (JF1)	
Pin#	Definition
5	3.3V
6	PWR Fail LED

Overheat/Fan Fail/UID LED

Connect an LED cable to pins 7 and 8 of JF1 for the Overheat/Fan Fail and UID LED connections. The red LED (pin 8) provides warning of an overheat or fan failure. The blue LED (pin 7) works as the UID LED indicator for the front panel UID button located on pins 13~14 of JF1. When Jumper J_UID_OW is set to off (default), the red LED takes precedence over the blue LED. Refer to the tables on the right for more information.

OH/Fan Fail/Blue_UID LED Pin Definitions (JF1)	
Pin#	Definition
7	Blue_LED-Cathode(UID)/5.5V.SB
8	OH/Fan Fail/UID LED (Red)

OH/Fan Fail LED Status (Red LED)	
State	Definition
Off	Normal
On	Overheat
Flashing	Fan Fail

NIC2 (LAN2) LED

The LED connections for LAN2 are on pins 9 and 10 of JF1. Attach an LED cable to display network activity. See the table on the right for pin definitions.

NIC2 LED Pin Definitions (JF1)	
Pin#	Definition
9	Activity LED
10	Link LED

NIC1 (LAN1) LED

The LED connections for LAN1 are on pins 11 and 12 of JF1. Attach an LED cable to display network activity. See the table on the right for pin definitions.

NIC1 LED Pin Definitions (JF1)	
Pin#	Definition
11	Activity LED
12	Link LED

HDD/FP UID Button

The HDD/UID button connections are located on pins 13/14 of JF1. Attach a hard-drive LED cable to display HDD or SATA activity. This connection can also be used for the front panel UID (Unit Identifier) button. (The UID LED on pin 7 of JF1 works in conjunction with the UID button.) When the user presses and releases the UID button, the UID LED will be turned on or off to indicate the location of the unit in a stack or rackmounted servers.

HDD/UID LED Pin Definitions (JF1)	
Pin#	Definition
13	UID Signal/3.3V
14	HDD Activity

Power On LED

The Power On LED connector is located on pins 15 and 16 of JF1. This connection is used to provide LED indication of power being supplied to the system. See the table on the right for pin definitions.

Power LED Pin Definitions (JF1)	
Pin#	Definition
15	+3.3V
16	Control

Fan Headers

The X9DRG-HF has twelve fan headers. Fans 1~4 are for CPU/system use and Fans A~H for GPU use.. All are 4-pin fan headers, which are backward compatible with traditional 3-pin fans. However, fan speed control is available for 4-pin fans only. See the table on the right for pin definitions.

Fan Header Pin Definitions	
Pin#	Definition
1	Ground
2	+12V
3	Tachometer
4	Pulse Width Modulation

Serial Ports

A COM Port (COM1) is located next to the UID switch to provide serial port support. See the table on the right for pin definitions.

Serial Port Pin Definitions			
Pin #	Definition	Pin #	Definition
1	DCD	6	DSR
2	RXD	7	RTS
3	TXD	8	CTS
4	DTR	9	RI
5	Ground	10	NC

NMI Header

The non-maskable interrupt header is located at JNMI1. Refer to the table on the right for pin definitions.

NMI Button Pin Definitions	
Pin#	Definition
1	Control
2	Ground

Internal Buzzer

The Speaker header, located at JSPK1, can be used to provide audible alarms for various beep codes. See the table on the right for pin definitions.

Internal Buzzer Pin Definitions		
Pin#	Definitions	
Pin 1	Pos. (+)	5V
Pin 2	Neg. (-)	Alarm Speaker

Chassis Intrusion

A Chassis Intrusion header is located at JL1 on the serverboard. Attach an appropriate cable from the chassis to inform you of a chassis intrusion when the chassis is opened.

Chassis Intrusion Pin Definitions	
Pin#	Definition
1	Intrusion Input
2	Ground

T-SGPIO Headers

Three SGPIO (Serial-Link General Purpose Input/Output) headers are provided on the serverboard. These headers support serial link interfaces for the onboard SATA ports. See the table on the right for pin definitions.

T-SGPIO Pin Definitions			
Pin#	Definition	Pin	Definition
1	NC	2	NC
3	Ground	4	Data
5	Load	6	Ground
7	Clock	8	NC

NC = No Connection

RAIDKey Header

A RAIDKey header (JRK1) provides RAID function support to enhance system performance.

RAIDKey Pin Definitions	
Pin#	Definition
1	Ground
2	Signal
3	Ground

TPM Header/Port 80

A Trusted Platform Module/Port 80 header is located at JTPM1 to provide TPM and Port 80 support, which will enhance system performance and data security. See the table on the right for pin definitions.

TPM/Port 80 Header Pin Definitions			
Pin# Definition		Pin # Definition	
1	LCLK	2	GND
3	LFRAME#	4	<(KEY)>
5	LRESET#	6	NC
7	LAD 3	8	LAD 2
9	+3.3V	10	LAD1
11	LAD0	12	GND
13	NC	14	NC
15	+3V_DUAL	16	SERIRQ
17	GND	18	CLKRUN# (X)
19	LPCPD#	20	NC

Universal Serial Bus (USB)

Two Universal Serial Bus ports (USB0/1) are located on the I/O backplane. Connect USB devices to these ports.

USB Pin Definitions	
Pin#	Definition
1	+5V
2	PO-
3	PO+
4	Ground
5	NA

Ethernet Ports

Two Ethernet ports are located next to the USB 0/1 on the IO backplane. In addition, an IPMI Dedicated LAN is located above the USB ports 0/1. These ports accept RJ45 type cables.

Notes: The X9DRG-HTF supports two X540-based 10G LAN ports, the X9DRG-HF supports two I350-based 1G LAN ports. Please refer to the Onboard Indicator Section for LAN LED information.

LAN Ports Pin Definition			
Pin#	Definition	Pin#	Definitions
1	TD0+	11	TD3-
2	TD0-	12	PIV8_NIC
3	PIV8_NIC	13	ACT LED-
4	TD1+	14	ACT LED+
5	TD1-	15	Link 100 LED (Green)
6	PIV8_NIC	16	Link 1000 LED (Yellow)
7	TD2+	17	Ground
8	TD2-	18	Ground
9	PIV8_NIC	19	Ground
10	TD3+	20	Ground

Unit Identifier Switch

A Unit Identifier (UID) switch and two LED indicators are provided on the serverboard. The rear UID LED (LE4) is located next to the rear UID switch. The front panel UID LED is on pins 7/8 of JF1. Connect a cable to pins 7/8 on JF1 for front panel UID indication. Pressing the UID switch will turn on both the rear and front UID LEDs. Pressing the UID switch again will turn off both LEDs. These UIDs provide easy identification of a system unit that may be in need of service.

Note: the UID can also be triggered via IPMI. Please refer to the IPMI User's Guide posted on our Website.

UID LED (LE4) Status		
Color/State	OS	Status
Blue: On	Windows OS	Unit Identified
Blue: Blinking	Linux OS	Unit Identified

UID Switch	
Pin#	Definition
1	Button In
2	Ground
3	Ground
4	Ground

Overheat LED/Fan Fail

The JOH1 header is used to connect an LED indicator to provide warnings of chassis overheating and fan failure. This LED will blink when a fan failure occurs. Refer to the tables on the right for pin definitions.

Overheat LED Pin Definitions	
Pin#	Definition
1	5vDC
2	OH Active

OH/Fan Fail LED Status	
State	Message
Solid	Overheat
Blinking	Fan Fail

Power SMB (I²C) Connectors

Power System Management Bus (I²C) Connectors (JI²C1/JI²C2) monitor power supply, fan and system temperatures. See the table on the right for pin definitions.

PWR SMB Pin Definitions	
Pin#	Definition
1	Clock
2	Data
3	PWR Fail
4	Ground
5	+3.3V

5-9 Jumper Settings

Explanation of Jumpers

To modify the operation of the serverboard, jumpers can be used to choose between optional settings. Jumpers create shorts between two pins to change the function of the connector. Pin 1 is identified with a square solder pad on the printed circuit board. See the serverboard layout pages for jumper locations.

Note: On a two-pin jumper, "Closed" means the jumper is on both pins and "Open" means the jumper is either on only one pin or completely removed.

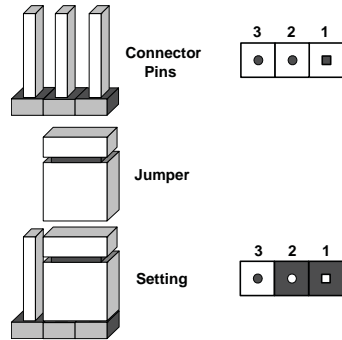

CMOS Clear

JBT1 is used to clear CMOS (which will also clear any passwords). Instead of pins, this jumper consists of contact pads to prevent accidentally clearing the contents of CMOS.

To clear CMOS,

1. First power down the system and unplug the power cord(s).
2. With the power disconnected, short the CMOS pads with a metal object such as a small screwdriver.
3. Remove the screwdriver (or shorting device).
4. Reconnect the power cord(s) and power on the system.

Note: Do not use the PW_ON connector to clear CMOS.

VGA Enable/Disable

JPG1 allows you to enable or disable the VGA port. The default position is on pins 1 and 2 to enable VGA. See the table on the right for jumper settings.

VGA Enable/Disable Jumper Settings	
Jumper Setting	Definition
Pins 1-2	Enabled
Pins 2-3	Disabled

LAN1/2 Enable/Disable

Change the setting of jumper JPL1 to enable or disable the LAN1/LAN2 Ethernet ports on the serverboard. See the table on the right for jumper settings. The default setting is enabled.

LAN1/2 Enable/Disable Jumper Settings	
Jumper Setting	Definition
Pins 1-2	Enabled
Pins 2-3	Disabled

Watch Dog Enable/Disable

JWD controls the Watch Dog function. Watch Dog is a system monitor that can reboot the system when a software application hangs. Jumping pins 1-2 (default) will cause WD to reset the system if an application hangs. Jumping pins 2-3 will generate a non-maskable interrupt signal for the application that hangs. See the table on the right for jumper settings. Watch Dog must also be enabled in BIOS.

Watch Dog Jumper Settings	
Jumper Setting	Definition
Pins 1-2	Reset
Pins 2-3	NMI
Open	Disabled

Note: When enabled, the user needs to write their own application software in order to disable the Watch Dog Timer.

Manufacturer Mode Select

Close jumper JPME1 to bypass SPI flash security and force the system to use the Manufacturer Mode, which will allow the user to flash the system firmware from a host server to modify system settings. See the table on the right for jumper settings.

ME Mode Select Jumper Settings	
Jumper Setting	Definition
1-2	Normal (Default)
2-3	Manufacture Mode

Write Protect Enable

Close pins 1/2 of jumper JWP1 to enable Write Protect support for system security and data integrity. See the table on the right for jumper settings.

Write Protect Jumper Settings	
Jumper Setting	Definition
Pins 1/2	Write_Protect Enable (Default)
Pins 2/3	Write_Protect Disable

BMC Enable/Disable

Use jumper JPB1 to enable or disable the BMC (Baseboard Management Controller), which supports IPMI 2.0/KVM. See the table on the right for jumper settings.

BMC Enable/Disable Jumper Settings	
Both Jumpers	Definition
Pins 1-2	Enabled
Pins 2-3	Disabled

5-10 Onboard Indicators

LAN1/2 Port LEDs

The Ethernet ports have two LEDs. On each port, one LED indicates activity while the other LED may be green, amber or off to indicate the speed of the connection. See the table on the right for the functions associated with the connection speed LED.

Note: the dedicated IPMI LAN does not operate at 1 Gb/s.

LAN1/2 LED (Connection Speed Indicator)	
LED Color	Definition
Off	No connection or 10/100 Mb/s
Green	1 Gb/s
Amber	10 Gb/s (X9DRG-HTF only)

Dedicated IPMI LAN Port LEDs

A dedicated IPMI LAN port is also located on the I/O backplane. The amber LED on the right indicates activity, while the green LED on the left indicates the speed of the connection. Please note that the IPMI LAN does not support 1Gbps connections. See the table at right for more information.

IPMI LAN LEDs		
	Color/State	Definition
Link (Left)	Green: Solid	100 Mbps
Activity (Right)	Amber: Blinking	Active

Onboard Power LED

An Onboard Power LED is located at LE1. This LED Indicator is on when the system is on. Be sure to unplug the AC power cable before removing or adding any components. See the table on the right for more details.

Onboard PWR LED Indicator	
LED Color	Definition
Off	System Off (power cable not connected)
Green	System On
Green: Flashing Quickly	ACPI S1 State

ME Recovery

JBR1 is used for ME Firmware Recovery mode, which will limit system resource for essential function use only without putting restrictions on power use. In the single operation mode, online upgrade will be available via Recovery mode. See the table on the right for jumper settings.

ME Recovery Select Jumper Settings	
Jumper Setting	Definition
1-2	Manufacture Mode
2-3	Normal (Default)

BMC Heartbeat LED

The BMC Heartbeat LED is designated DM1. When DM1 is blinking, the BMC (Baseboard Management Controller) is functioning normally. See the table at right for more information.

BMC Heartbeat LED Indicator LED Status	
Green: Blinking	BMC: Normal

Rear UID LED

The rear UID LED is located at LE4 on the backplane. This LED is used in conjunction with the rear UID switch to provide easy identification of a system that might be in need of service.

UID LED Status		
Color/State	OS	Status
Blue: On	Windows OS	Unit Identified
Blue: Blinking	Linux OS	Unit Identified

5-11 SATA Ports

SATA Ports

Two SATA 3.0 ports (I-SATA0 and I-SATA1) and eight SATA 2.0 ports (I-SATA2 through I-SATA5 and S-SATA0 through S-SATA3) are included on the serverboard. There are no jumpers to configure the onboard SATA ports. See the table on the right for pin definitions.

SATA Port Pin Definitions	
Pin #	Definition
1	Ground
2	TXP
3	TXN
4	Ground
5	RXN
6	RXP
7	Ground

5-12 Installing Software

After the hardware has been installed, you should first install the operating system and then the drivers. The necessary drivers are all included on the Supermicro CDs that came packaged with your system.



Driver/Tool Installation Display Screen

Note: Click the icons showing a hand writing on paper to view the readme files for each item. Click the computer icons to the right of these items to install each item (from top to the bottom) one at a time. **After installing each item, you must re-boot the system before moving on to the next item on the list.** The bottom icon with a CD on it allows you to view the entire contents of the CD.

Supero Doctor III

The Supero Doctor III program is a web-based management tool that supports remote management capability. It includes Remote and Local Management tools. The local management is called SD III Client. The Supero Doctor III program included on the CD-ROM that came with your serverboard allows you to monitor the environment and operations of your system. Supero Doctor III displays crucial system information such as CPU temperature, system voltages and fan status. See the Figure below for a display of the Supero Doctor III interface.

Note: The default User Name and Password for SuperDoctor III is ADMIN / ADMIN.

Note: When SuperDoctor III is first installed, it adopts the temperature threshold settings that have been set in BIOS. Any subsequent changes to these thresholds must be made within Super Doctor, as the Super Doctor settings override the BIOS settings. To set the BIOS temperature threshold settings again, you would first need to uninstall SuperDoctor III.

Supero Doctor III Interface Display Screen (Health Information)

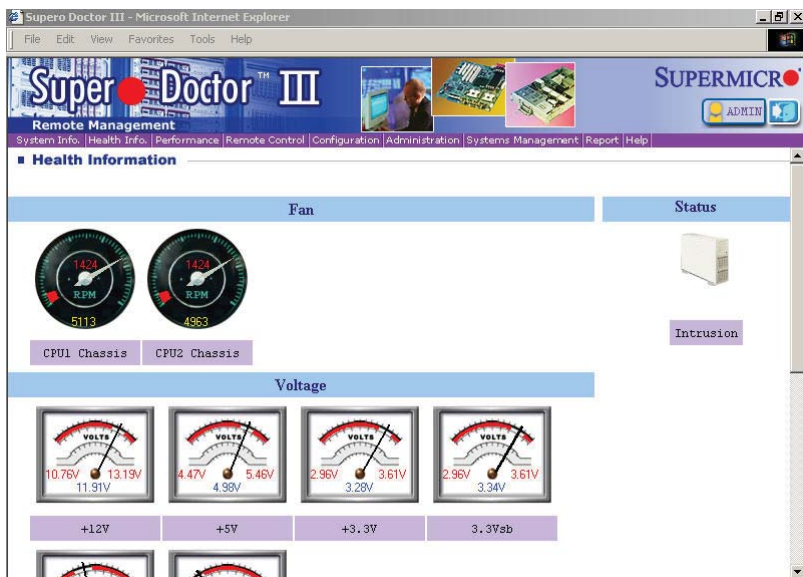

Supero Doctor III Interface Display Screen (Remote Control)

Graceful power control

Supero Doctor III allows a user to inform the OS to reboot or shut down within a specified time (the default is 30 seconds). Before the system reboots or shuts down, it's allowed to cancel the action.

Requirements

Keep Supero SD3Service Daemon running at all times on this system.
Provide TCP/IP connectivity.

Power control

Note: SD III Software Revision 1.0 can be downloaded from our Web Site at: ftp://ftp.supermicro.com/utility/Supero_Doctor_III/. You can also download the SDIII User's Guide at: http://www.supermicro.com/manuals/other/SDIII_User_Guide.pdf. For Linux, we will recommend using Supero Doctor II.

Notes

Chapter 6

Advanced Chassis Setup

This chapter covers the steps required to install components and perform maintenance on the SC118GQTS chassis. For component installation, follow the steps in the order given to eliminate the most common problems encountered. If some steps are unnecessary, skip ahead to the next step.

Tools Required: The only tool you will need to install components and perform maintenance is a Philips screwdriver.

6-1 Static-Sensitive Devices

Electrostatic Discharge (ESD) can damage electronic components. To prevent damage to any printed circuit boards (PCBs), it is important to handle them very carefully.

The following measures are generally sufficient to protect your equipment from ESD damage.

Precautions

- Use a grounded wrist strap designed to prevent static discharge.
- Touch a grounded metal object before removing any board from its antistatic bag.
- Handle a board by its edges only; do not touch its components, peripheral chips, memory modules or gold contacts.
- When handling chips or modules, avoid touching their pins.
- Put the serverboard, add-on cards and peripherals back into their antistatic bags when not in use.
- For grounding purposes, make sure your computer chassis provides excellent conductivity between the power supply, the case, the mounting fasteners and the serverboard.

Figure 6-1. Chassis: Front and Rear Views

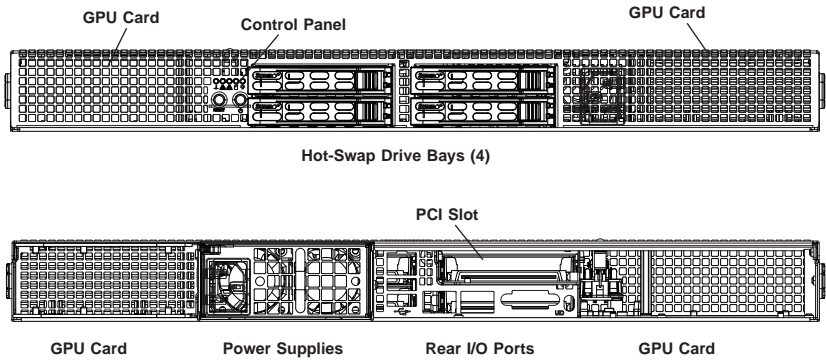

Note: the number of PCI slots available depends on the presence of GPUs in the server model.

6-2 Control Panel

The control panel (located on the front of the chassis) must be connected to the JF1 connector on the serverboard to provide you with system status indications. A ribbon cable has bundled these wires together to simplify the connection. Connect the cable from JF1 on the serverboard to the appropriate header on the Control Panel PCB (printed circuit board). Make sure the red wire plugs into pin 1 on both connectors. Pull all excess cabling out of the airflow path.

The control panel LEDs inform you of system status. See "Chapter 3: System Interface" for details on the LEDs and the control panel buttons. Details on JF1 can be found in "Chapter 5: Advanced Serverboard Installation."

6-3 System Cooling

Twelve 4-cm counter-rotating fans provide the cooling for the system. Each fan unit is actually made up of two fans joined back-to-back, which rotate in opposite directions. This counter-rotating action generates exceptional airflow and works to dampen vibration levels.

It is very important that the chassis top cover is properly installed and making a good seal in order for the cooling air to circulate properly through the chassis and cool the components.

System Fan Failure

Fan speed is controlled by system temperature via IPMI. If a fan fails, the remaining fans will ramp up to full speed. Replace any failed fan at your earliest convenience with the same type and model (the system can continue to run with a failed fan). Failed fans can be identified through the BIOS. (See the fan numbering in Figure 6-3. These numbers are also imprinted on the floor of the chassis.)

Replacing a System Fan

1. If the BIOS is not being utilized to determine which fan has failed, open the top cover of the chassis while the system is running to locate the position of the failed fan. Never run the server for an extended period of time with the top cover open.
2. Turn off the power to the system and unplug the AC power cord.
3. Remove the failed fan's wiring from the serverboard.
4. Remove the four pins securing the fan to the fan tray.
5. Lift the failed fan from the fan tray and out of the chassis.
6. Place the new fan into the vacant space in the fan tray, while making sure the arrows on the top of the fan (indicating air direction) point in the same direction as the arrows on the other fans in the same fan tray.
7. Reconnect the fan wires to the exact same chassis fan headers as the previous fan.
8. Reconnect the AC power cord, power up the system and check that the fan is working properly before replacing the chassis cover.

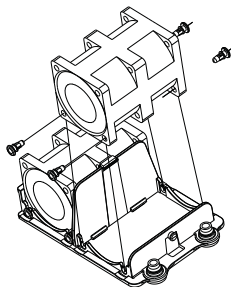

Figure 6-2. Removing a Fan from the Fan Tray

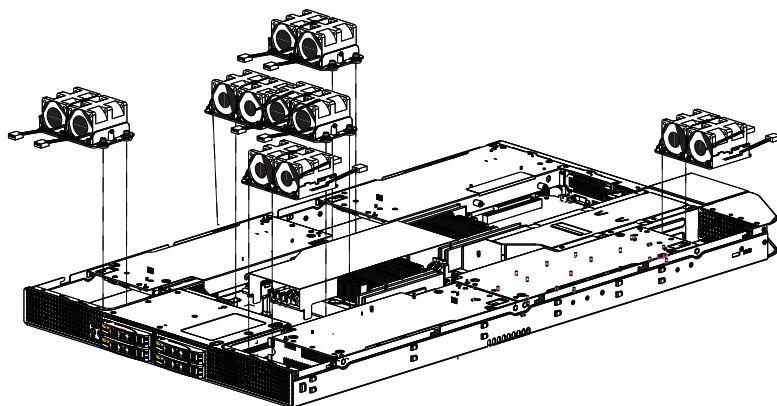

Figure 6-3: Installing a Fan

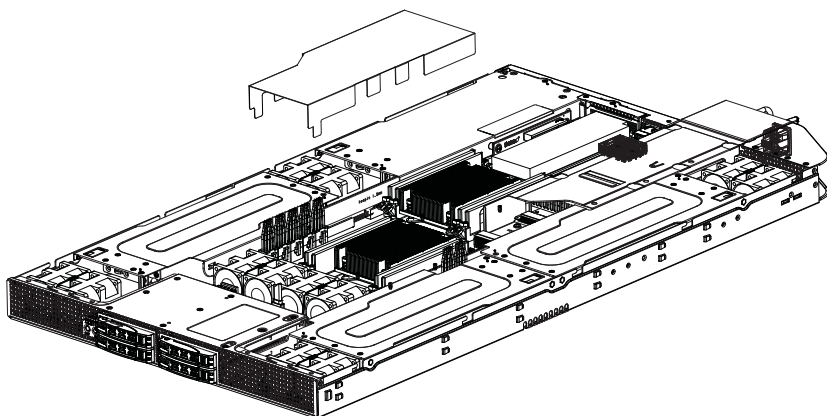

Figure 6-4: Installing the Air Shroud

Installing the Air Shroud

Air shrouds concentrate airflow to maximize fan efficiency. The SC118GQTS chassis air shroud does not require screws to set up.

Note: Each GPU card has its own air shroud.

Installing the Air Shroud

1. Position the air shroud in the chassis as illustrated in Figure 6-4.
2. Align the notch on the air shroud with the pin on the add-on card bracket.
3. Slide the pin into the back of the notch.
4. Lower the front of the air shroud over the fan tray, sliding the front notches over the pins on the fan tray.

Installing Graphics (GPU) Cards

The SC118GQTS chassis supports four GPU cards, which are mounted in brackets to fit into the PCI-E 3.0 slots. Supported GPU cards include NVIDIA M2090 and M2075. The GPU cards may be preinstalled, the procedure below is provided for when a GPU card need to be replaced.

Installing Graphics Cards

1. Identify the left and right brackets and graphics cards as illustrated below.
2. Insert the graphics cards into the brackets, aligning the mounting holes in the graphics cards with the mounting holes in the brackets.
3. Secure each card to the bracket using the six screws which are included for this purpose.
4. Carefully position each bracket in the chassis, aligning the four mounting holes in the top and side of each bracket with the corresponding mounting holes in the chassis.
5. Secure the bracket to the chassis by using the screws provided.
6. After a GPU card is installed, you must connect it to one of the following power headers on the serverboard: JPW3, JPW4, JPW6, JPW7, JPW8 or JPW11..

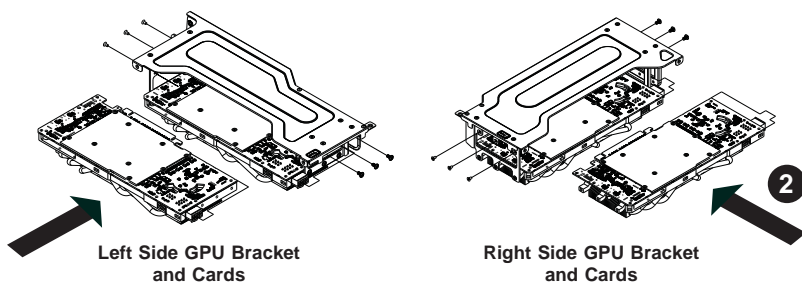
Figure 6-5. Installing GPU Cards into the Left and Right GPU Brackets

6-4 Drive Bay Installation/Removal

Accessing the Drive Bays

Because of their hotswap capability, you do not need to access the inside of the chassis or power down the system to install or replace hard drives. Proceed to the next section for instructions.

Hard Drive Installation

The hard drives are mounted in drive carriers to simplify their installation and removal from the chassis. These carriers also help promote proper airflow for the drive bays. For this reason, even empty carriers without drives installed must remain in the chassis.

Removing Hard Drive Carriers from the Chassis

1. Press the release button on the drive carrier. This extends the drive carrier handle.
2. Use the handle to pull the drive carrier out of the chassis.

Installing a Hard Drive into a Drive Carrier

1. Remove the dummy drive, which comes pre-installed in the drive carrier, by removing the screws securing the dummy drive to the carrier. Note that these screws cannot be reused on the actual 2.5" hard drive.
2. Insert a drive into the carrier with the PCB side facing down and the connector end toward the rear of the carrier.

3. Align the drive in the carrier so that the screw holes of both line up. Note that there are holes in the carrier marked "SATA" to aid in correct installation.
4. Secure the drive to the carrier with four M3 screws as illustrated below. These screws are included in the chassis accessory box.
5. Insert the drive carrier into its bay, keeping the carrier oriented so that the hard drive is on the top of the carrier and the release button is on the right side. When the carrier reaches the rear of the bay, the release handle will retract.
6. Push the handle in until it clicks into its locked position



Warning: Except for short periods of time (swapping hard drives), do not operate the server with the hard drive carriers removed.

Figure 6-6. Removing a Hard Drive Carrier

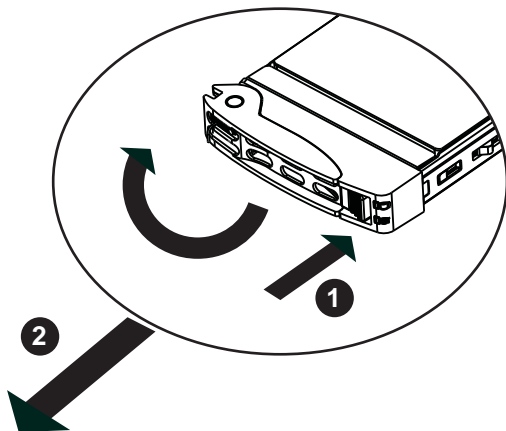

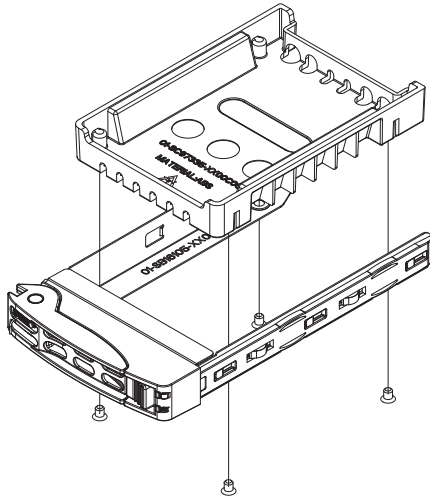

Figure 6-7. Installing a Hard Drive into a Carrier



Enterprise level hard disk drives are recommended for use in Supermicro chassis and servers. For information on recommended HDDs, visit the Supermicro Web site at <http://www.supermicro.com/products/info/storage.cfm>

6-5 Power Supply

The 1027GR-TQF/1027GR-TQFT series server includes a single 1800 watt power supply. The power supply module has an auto-switching capability, which enables it to automatically sense and operate at a 100V - 240V input voltage.

If the power supply fails, the server must be shutdown and the power cord disconnected before replacing with a new power supply module. Replacement units can be ordered directly from Supermicro.

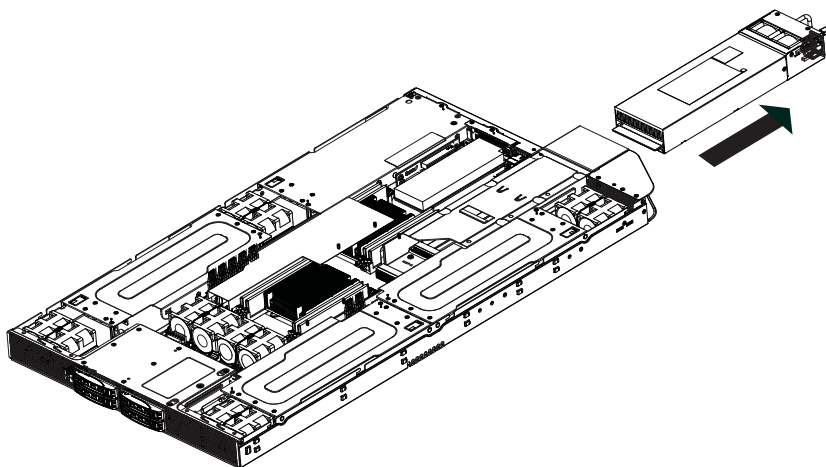

Figure 6-8. Removing the Power Supply

Replacing the Power Supply

1. First make sure the server is powered off, then unplug the AC power cord from the failed power supply module.
2. To remove the failed power unit, push in the locking tab at the back of the module to release it. You can then pull the unit straight out of the chassis.
3. Replace the failed unit with another of the exact same power supply.
4. Carefully insert the new unit into position in the chassis and secure it with the screws at the rear of the unit.
5. Reconnect the AC power cord and restart the server.

Notes

Chapter 7

BIOS

7-1 Introduction

This chapter describes the AMI BIOS Setup utility for the X9DRG-HF/HTF. It also provides the instructions on how to navigate the AMI BIOS Setup utility screens. The AMI ROM BIOS is stored in a Flash EEPROM and can be easily updated.

Starting BIOS Setup Utility

To enter the AMI BIOS Setup utility screens, press the key while the system is booting up.

 **Note:** In most cases, the key is used to invoke the AMI BIOS setup screen. There are a few cases when other keys are used, such as <F3>, <F4>, etc.

Each main BIOS menu option is described in this manual. The Main BIOS setup menu screen has two main frames. The left frame displays all the options that can be configured. Grayed-out options cannot be configured. Options in blue can be configured by the user. The right frame displays the key legend. Above the key legend is an area reserved for a text message. When an option is selected in the left frame, it is highlighted in white. Often a text message will accompany it.

 **Note:** The AMI BIOS has default text messages built in. The manufacturer retains the option to include, omit, or change any of these text messages.

The AMI BIOS Setup utility uses a key-based navigation system called "hot keys." Most of the AMI BIOS setup utility "hot keys" can be used at any time during setup navigation. These keys include <F3>, <F4>, <Enter>, <ESC>, arrow keys, etc.

 **Note 1:** Options printed in **Bold** are default settings.

Note 2: <F3> is used to load optimal default settings. <F4> is used to save the settings and exit the setup utility.

How To Change the Configuration Data

The configuration data that determines the system parameters may be changed by entering the AMI BIOS Setup utility. This Setup utility can be accessed by pressing <Delete> at the appropriate time during system boot.

 **Note:** For AMI UEFI BIOS Recovery, please refer to the UEFI BIOS Recovery User Guide posted @<http://www.supermicro.com/support/manuals/>.

Starting the Setup Utility

Normally, the only visible Power-On Self-Test (POST) routine is the memory test. As the memory is being tested, press the <Delete> key to enter the main menu of the AMI BIOS Setup utility. From the main menu, you can access the other setup screens. An AMI BIOS identification string is displayed at the left bottom corner of the screen below the copyright message.



Warning! Do not upgrade the BIOS unless your system has a BIOS-related issue. Flashing the wrong BIOS can cause irreparable damage to the system. In no event shall the manufacturer be liable for direct, indirect, special, incidental, or consequential damage arising from a BIOS update. If you have to update the BIOS, do not shut down or reset the system while the BIOS is being updated to avoid possible boot failure.

7-2 Main Setup

When you first enter the AMI BIOS Setup utility, you will enter the Main setup screen. You can always return to the Main setup screen by selecting the Main tab on the top of the screen. The Main BIOS Setup screen is shown below.



The AMI BIOS Main menu displays the following information:

System Date/System Time

Use this option to change the system time and date. Highlight *System Time* or *System Date* using the arrow keys. Enter new values through the keyboard and press <Enter>. Press the <Tab> key to move between fields. The date must be entered in Day MM/DD/YY format. The time is entered in HH:MM:SS format. (**Note:** The time is in the 24-hour format. For example, 5:30 P.M. appears as 17:30:00.).

Supermicro X9DRG-HF**Version**

This item displays the SMC version of the BIOS ROM used in this system.

Build Date

This item displays the date that the BIOS Setup utility was built.

Memory Information**Total Memory**

This displays the amount of memory that is available in the system.

7-3 Advanced Setup Configurations

Select the Advanced tab to access the following submenu items.

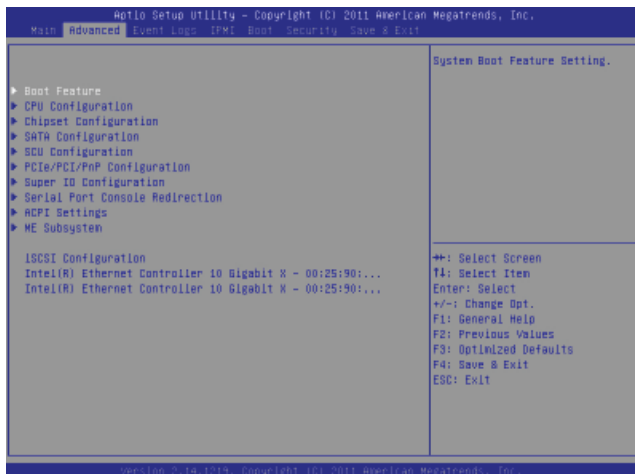

► Boot Features

Quiet Boot

This feature allows the user to select bootup screen display between POST messages and the OEM logo. Select Disabled to display the POST messages. Select Enabled to display the OEM logo instead of the normal POST messages. The options are **Enabled** and Disabled.

AddOn ROM Display Mode

Use this item to set the display mode for the Option ROM. Select Keep Current to use the current AddOn ROM Display setting. Select Force BIOS to use the Option ROM display mode set by the system BIOS. The options are **Force BIOS** and Keep Current.

Bootup Num-Lock

Use this feature to set the Power-on state for the Numlock key. The options are Off and **On**.

Wait For 'F1' If Error

Select Enabled to force the system to wait until the 'F1' key is pressed if an error occurs. The options are Disabled and **Enabled**.

Interrupt 19 Capture

Interrupt 19 is the software interrupt that handles the boot disk function. When this item is set to Enabled, the ROM BIOS of the host adaptors will "capture" Interrupt 19 at bootup and allow the drives that are attached to these host adaptors to function as bootable disks. If this item is set to Disabled, the ROM BIOS of the host adaptors will not capture Interrupt 19, and the drives attached to these adaptors will not function as bootable devices. The options are **Enabled** and Disabled.

Power Configuration

Watch Dog Function

If enabled, the Watch Dog timer will allow the system to reboot when it is inactive for more than 5 minutes. The options are Enabled and **Disabled**.

Power Button Function

If this feature is set to Instant Off, the system will power off immediately as soon as the user presses the power button. If this feature is set to 4 Seconds Override, the system will power off when the user presses the power button for 4 seconds or longer. The options are **Instant Off** and 4 Seconds Override.

Restore on AC Power Loss

Use this feature to set the power state after a power outage. Select Stay Off for the system power to remain off after a power loss. Select Power On for the system power to be turned on after a power loss. Select Last State to allow the system to resume its last state before a power loss. The options are Power On, Stay Off, and **Last State**.

►CPU Configuration

This submenu displays the information of the CPU as detected by the BIOS. It also allows the user to configuration CPU settings.

►Socket 1 CPU Information/Socket 2 CPU Information

This submenu displays the following information regarding the CPUs installed in Socket 1/ Socket 2.

- Type of CPU
- CPU Signature
- Microcode Patch

- CPU Stepping
- Maximum CPU Speed
- Minimum CPU Speed
- Processor Cores
- Intel HT (Hyper-Threading) Technology
- Intel VT-x Technology
- Intel SMX Technology
- L1 Data Cache
- L1 Code Cache
- L2 Cache
- L3 Cache

CPU Speed

This item displays the speed of the CPU installed in Socket 1/Socket 2.

64-bit

This item indicates if the CPU installed in Socket 1 or Socket 2 supports 64-bit technology.

Clock Spread Spectrum

Select Enable to enable Clock Spectrum support, which will allow the BIOS to monitor and attempt to reduce the level of Electromagnetic Interference caused by the components whenever needed. The options are **Disabled** and Enabled.

RTID (Record Types IDs)

This feature displays the total number of Record Type IDs for local and remote pools. The options are **Optimal** and Alternate.

Hyper-threading

Select Enabled to support Intel Hyper-threading Technology to enhance CPU performance. The options are **Enabled** and Disabled.

Active Processor Cores

Set to Enabled to use a processor's second core and above. (Please refer to Intel's website for more information.) The options are **All**, 1, 2, 4 and 6.

Limit CPUID Maximum

This feature allows the user to set the maximum CPU ID value. Enable this function to boot the legacy operating systems that cannot support processors with extended CPUID functions. The options are Enabled and **Disabled** (for the Windows OS).

Execute-Disable Bit (Available if supported by the OS & the CPU)

Select Enabled to enable the Execute Disable Bit which will allow the processor to designate areas in the system memory where an application code can execute and where it cannot, thus preventing a worm or a virus from flooding illegal codes to overwhelm the processor or damage the system during an attack. The default is **Enabled**. (Refer to Intel and Microsoft Web sites for more information.)

Intel® AES-NI

Select Enable to use the Intel Advanced Encryption Standard (AES) New Instructions (NI) to ensure data security. The options are **Enabled** and Disabled.

MLC Streamer Prefetcher (Available when supported by the CPU)

If set to Enabled, the MLC (mid-level cache) streamer prefetcher will prefetch streams of data and instructions from the main memory to the L2 cache to improve CPU performance. The options are Disabled and **Enabled**.

MLC Spatial Prefetch (Available when supported by the CPU)

If this feature is set to Disabled, The CPU prefetches the cache line for 64 bytes. If this feature is set to Enabled the CPU fetches both cache lines for 128 bytes as comprised. The options are Disabled and **Enabled**.

DCU Streamer Prefetcher (Available when supported by the CPU)

Select Enabled to support Data Cache Unite (DCU) prefetch of L1 data to speed up data accessing and processing in the DCU to enhance CPU performance. The options are Disabled and **Enabled**.

DCU IP Prefetcher

Select Enabled for DCU (Data Cache Unit) IP Prefetcher support, which will prefetch IP addresses to improve network connectivity and system performance. The options are **Enabled** and Disabled.

Intel® Virtualization Technology (Available when supported by the CPU)

Select Enabled to support Intel Virtualization Technology, which will allow one platform to run multiple operating systems and applications in independent partitions, creating multiple "virtual" systems in one physical computer. The options are **Enabled** and Disabled.

 **Note:** If there is any change to this setting, you will need to power off and restart the system for the change to take effect. Please refer to Intel's website for detailed information.)

► CPU Power Management Configuration

This submenu allows the user to configure the following CPU Power Management settings.

Power Technology

Select Energy Efficiency to support power-saving mode. Select Custom to customize system power settings. Select Disabled to disable power-saving settings. The options are Disabled, **Energy Efficient**, and Custom. If the option is set to Custom, the following items will display:

EIST (Available when Power Technology is set to Custom)

EIST (Enhanced Intel SpeedStep Technology) allows the system to automatically adjust processor voltage and core frequency to reduce power consumption and heat dissipation. The options are Disabled (GV3 Disabled), and **Enabled (GV3 Enabled)**. (**Note:** GV3 is Intel Speedstep support used on older platforms. Please refer to Intel's website for detailed information.)

Turbo Mode (Available when Power Technology is set to Custom)

Select Enabled to use the Turbo Mode to boost system performance. The options are **Enabled** and Disabled.

C1E (Available when Power Technology is set to Custom)

Select Enabled to enable Enhanced C1 Power State to boost system performance. The options are **Enabled** and Disabled.

CPU C3 Report (Available when Power Technology is set to Custom)

Select Enabled to allow the BIOS to report the CPU C3 State (ACPI C2) to the operating system. During the CPU C3 State, the CPU clock generator is turned off. The options are Enabled and **Disabled**.

CPU C6 Report (Available when Power Technology is set to Custom)

Select Enabled to allow the BIOS to report the CPU C6 State (ACPI C3) to the operating system. During the CPU C6 State, the power to all cache is turned off. The options are **Enabled** and Disabled.

CPU C7 Report (Available when Power Technology is set to Custom)

Select Enabled to allow the BIOS to report the CPU C7 State (ACPI C3) to the operating system. CPU C7 State is a processor-specific low C-State. The options are **Enabled** and Disabled.

Package C-State limit (Available when Power Technology is set to Custom)

This feature allows the user to set the limit on the C-State package register. The options are C0, C2, **C6**, and No Limit.

Energy/Performance Bias

This setting allows the user to adjust the fan speed based on performance (maximum cooling) or energy efficiency (maximum energy savings). The options are Performance, **Balanced Performance**, Balanced Energy, and Energy Efficient.

Factory Long Duration Power Limit

This item displays the power limit set by the manufacturer during which long duration power is maintained.

Long Duration Power Limit

This item displays the power limit set by the user during which long duration power is maintained. The default setting is 0.

Factory Long Duration Maintained

This item displays the period of time set by the manufacturer during which long duration power is maintained.

Long Duration Maintained

This item displays the period of time during which long duration power is maintained. The default setting is 0.

Recommended Short Duration Power

This item displays the short duration power settings recommended by the manufacturer.

Short Duration Power Limit

This item displays the time period during which short duration power is maintained. The default setting is 0.

► Chipset Configuration

► North Bridge

This feature allows the user to configure the settings for the Intel North Bridge.

► Integrated IO Configuration

Intel VT-d

Select Enabled to enable Intel Virtualization Technology support for Direct I/O VT-d by reporting the I/O device assignments to the VWM (Virtual Working Memory) through the DMAR ACPI Tables. This feature offers fully-protected I/O resource sharing across Intel platforms, providing greater reliability, security and availability in networking and data-sharing. The options are **Enabled** and Disabled.

Data Direct I/O

Select Enabled to enable Intel I/OAT (I/O Acceleration Technology), which significantly reduces CPU overhead by leveraging CPU architectural improvements and freeing the system resource for other tasks. The options are Disabled and **Enabled**.

DCA Support

When set to Enabled, this feature uses Intel's DCA (Direct Cache Access) Technology to improve data transfer efficiency. The default is **Enabled** and can not be changed.

IIO 1 PCIe Port Bifurcation Control

This submenu configures the following IO PCIe Port Bifurcation Control settings for IIO 1 PCIe ports to determine how the available PCI-Express lanes to be distributed between the PCI-Exp. Root Ports.

CPU1 Slot 5 PCI-E 3.0 x8 OPROM

This feature allows the user to set the PCI-Exp bus speed for the slot specified above. The options are Gen1 (Generation 1), Gen2 and **Gen3**.

CPU1 Slot 2 PCI-E 3.0 x16 OPROM

This feature allows the user to set the PCI-Exp bus speed for the slot specified above. The options are Gen1 (Generation 1), Gen2 and **Gen3**.

CPU1 Slot 1 PCI-E 3.0 x16 OPROM

This feature allows the user to set the PCI-Exp bus speed for the slot specified above. The options are Gen1 (Generation 1), Gen2 and **Gen3**.

IIO 2 PCIe Port Bifurcation Control

This submenu configures the following IO PCIe Port Bifurcation Control settings for IIO 2 PCIe ports to determine how the available PCI-Express lanes to be distributed between the PCI-Exp. Root Ports.

CPU2 Slot 3 PCI-E 3.0 x16 OPROM

This feature allows the user to set the PCI-Exp bus speed for the slot specified above. The options are Gen1 (Generation 1), Gen2 and **Gen3**.

CPU2 Slot 4 PCI-E 3.0 x16 OPROM

This feature allows the user to set the PCI-Exp bus speed for the slot specified above. The options are Gen1 (Generation 1), Gen2 and **Gen3**.

►QPI Configuration**Current QPI Link**

This item displays the current status of the QPI Link.

Current QPI Frequency

This item displays the frequency of the QPI Link.

Isoc

Select Enabled to enable Isynchronous support to meet QoS (Quality of Service) requirements. This feature is especially important for virtualization technology. The options are Enabled and **Disabled**.

QPI (Quick Path Interconnect) Link Speed Mode

Use this feature to select data transfer speed for QPI Link connections. The options are **Fast** and Slow.

QPI Link Frequency Select

Use this feature to select the desired QPI frequency. The options are **Auto**, 6.4 GT/s, 7.2 GT/s, and 8.0 GT/s.

► DIMM Configuration

This section displays the following DIMM information.

Current Memory Mode

This item displays the current memory mode.

Current Memory Speed

This item displays the current memory speed.

Mirroring

This item displays if memory mirroring is supported by the motherboard. Memory mirroring creates a duplicate copy of the data stored in the memory to enhance data security.

Sparing

This item displays if memory sparing is supported by the motherboard. Memory sparing enhances system performance.

► DIMM Information

CPU Socket 1 DIMM Information/ CPU Socket 2 DIMM Information

The status of the memory modules detected by the BIOS will be displayed as detected by the BIOS.

Memory Mode

When Independent is selected, all DIMMs are available to the operating system. When Mirroring is selected, the motherboard maintains two identical copies of all data in memory for data backup. When Lock Step is selected, the motherboard uses two areas of memory to run the same set of operations in parallel. The options are **Independent**, Mirroring, and Lock Step.

DRAM RAPL Mode

RAPL (Running Average Power Limit) provides mechanisms to enforce power consumption limits on supported processors. The options are DRAM RAPL MODE0, **DRAM RAPL MODE1**, and Disabled.

DDR Speed

Use this feature to force a DDR3 memory module to run at a frequency other than what is specified in the specification. The options are **Auto**, Force DDR3-800, Force DDR3-1066, Force DDR3-1333, Force DDR3-1600 and Force SPD.

Channel Interleaving

This feature selects from the different channel interleaving methods. The options are **Auto**, 1 Way, 2 Way, 3, Way, and 4 Way.

Rank Interleaving

This feature allows the user to select a rank memory interleaving method. The options are **Auto**, 1 Way, 2 Way, 4, Way, and 8 Way.

Patrol Scrub

Patrol Scrubbing is a process that allows the CPU to correct correctable memory errors detected on a memory module and send the correction to the requestor (the original source). When this item is set to Enabled, the IO hub will read and write back one cache line every 16K cycles, if there is no delay caused by internal processing. By using this method, roughly 64 GB of memory behind the IO hub will be scrubbed every day. The options are **Enabled** and Disabled.

Demand Scrub

Demand Scrubbing is a process that allows the CPU to correct correctable memory errors found on a memory module. When the CPU or I/O issues a demand-read command, and the read data from memory turns out to be a correctable error, the error is corrected and sent to the requestor (the original source). Memory is updated as well. Select Enabled to use Demand Scrubbing for ECC memory correction. The options are Enabled and **Disabled**.

Data Scrambling

Select Enabled to enable data scrambling to ensure data security and integrity. The options are Disabled and **Enabled**.

Device Tagging

Select Enabled to support device tagging. The options are **Disabled** and Enabled.

Thermal Throttling

Throttling improves reliability and reduces power consumption in the processor via automatic voltage control during processor idle states. The options are Disabled and **CLTT** (Closed Loop Thermal Throttling).

► South Bridge Configuration

This feature allows the user to configure the settings for the Intel PCH chip.

PCH Information

This feature displays the following PCH information.

Name: This item displays the name of the PCH chip.

Stepping: This item displays the status of the PCH stepping.

USB Devices: This item displays the USB devices detected by the BIOS.

All USB Devices

This feature enables all USB ports/devices. The options are Disabled and **Enabled**. (If set to Enabled, EHCI Controller 1 and Controller 2 will appear.)

EHCI Controller 1/EHCI Controller 2 (Available when All USB Devices is set to Enabled)

Select Enabled to enable EHCI (Enhanced Host Controller Interface) Controller 1 or Controller 2. The options are Disabled and **Enabled**.

Legacy USB Support (Available when USB Functions is not Disabled)

Select Enabled to support legacy USB devices. Select Auto to disable legacy support if USB devices are not present. Select Disable to have USB devices available for EFI (Extensive Firmware Interface) applications only. The settings are Disabled, **Enabled** and Auto.

Port 60/64 Emulation

Select Enabled to enable I/O port 60h/64h emulation support for the legacy USB keyboard so that it can be fully supported by the operating systems that does not recognize a USB device. The options are Disabled and **Enabled**.

EHCI Hand-Off

This item is for operating systems that do not support Enhanced Host Controller Interface (EHCI) hand-off. When enabled, EHCI ownership change will be claimed by the EHCI driver. The options are **Disabled** and Enabled.

► SATA Configuration

When this submenu is selected, the AMI BIOS automatically detects the presence of IDE or SATA devices and displays the following items.

SATA Port0~SATA Port5: The AMI BIOS displays the status of each SATA port as detected by the BIOS.

SATA Mode

Use this feature to configure SATA mode for a selected SATA port. The options are Disabled, IDE Mode, **AHCI Mode** and RAID Mode. The following are displayed depending on your selection:

IDE Mode

The following items are displayed when IDE Mode is selected:

Serial-ATA (SATA) Controller 0~1

Use this feature to activate or deactivate the SATA controller, and set the compatibility mode. The options for SATA Controller 0 are Disabled, Enhanced, and **Compatible**. The options for SATA Controller 1 are Disabled and **Enhanced**.

AHCI Mode

The following items are displayed when the AHCI Mode is selected.

Aggressive Link Power Management

Select Enabled to enable Aggressive Link Power Management support for Cougar Point B0 stepping and beyond. The options are **Enabled** and Disabled.

Port 0~5 Hot Plug

Select Enabled to enable hot-plug support for a particular port, which will allow the user to change a hardware component or device without shutting down the system. The options are **Enabled** and Disabled.

Staggered Spin Up

Select Enabled to enable Staggered Spin-up support to prevent excessive power consumption caused by multiple HDDs spinning-up simultaneously. The options are Enabled and **Disabled**.

RAID Mode

The following items are displayed when RAID Mode is selected:

Port 0~5 Hot Plug

Select Enabled to enable hot-plug support for the particular port. The options are **Enabled** and Disabled.

► SCU (Storage Control Unit) Configuration

Storage Controller Unit

Select Enabled to enable PCH SCU storage devices. The options are Disabled and **Enabled**.

OnChip SCU Option ROM

Select Enabled to support the onboard SCU Option ROM to boot up the system via a storage device. The options are Disabled and **Enabled**.

SCU Port 0~SCU Port 3: The AMI BIOS will automatically detect the onboard SCU devices and display the status of each SCU device as detected.

► PCIe/PCI/PnP Configuration

PCI ROM Priority

Use this feature to select the Option ROM to boot the system when there are multiple Option ROMs available in the system. The options are EFI Compatible ROM and **Legacy ROM**.

PCI Latency Timer

Use this feature to set the latency Timer of each PCI device installed on a PCI bus. Select 64 to set the PCI latency to 64 PCI clock cycles. The options are 32, **64**, 96, 128, 160, 192, 224 and 248.

Above 4G Decoding (Available if the system supports 64-bit PCI decoding)

Select Enabled to decode a PCI device that supports 64-bit in the space above 4G Address. The options are Enabled and **Disabled**.

PERR# Generation

Select Enabled to allow a PCI device to generate a PERR number for a PCI Bus Signal Error Event. The options are Enabled and **Disabled**.

SERR# Generation

Select Enabled to allow a PCI device to generate an SERR number for a PCI Bus Signal Error Event. The options are Enabled and **Disabled**.

Maximum Payload

Select Auto to allow the system BIOS to automatically set the maximum payload value for a PCI-E device to enhance system performance. The options are **Auto**, 128 Bytes and 256 Bytes.

Maximum Read Request

Select Auto to allow the system BIOS to automatically set the maximum Read Request size for a PCI-E device to enhance system performance. The options are **Auto**, 128 Bytes, 256 Bytes, 512 Bytes, 1024 Bytes, 2048 Bytes, and 4096 Bytes.

ASPM Support

This feature allows the user to set the Active State Power Management (ASPM) level for a PCI-E device. Select Force L0 to force all PCI-E links to operate at L0 state. Select Auto to allow the system BIOS to automatically set the ASPM level for the system. Select Disabled to disable ASPM support. The options are **Disabled**, Force L0, and Auto.



Warning: Enabling ASPM support may cause some PCI-E devices to fail!

**CPU1 Slot 1 PCI-E 3.0 x16 OPROM/ CPU1 Slot 2 PCI-E 3.0 x16 OPROM/
CPU1 Slot 5 PCI-E 3.0 x8 OPROM/ CPU2 Slot 3 PCI-E 3.0 x16 OPROM/
CPU2 Slot 4 PCI-E 3.0 x16 OPROM**

Select Enabled to enable Option ROM support to boot the computer using a network interface from the slots specified above. The options are **Enabled** and Disabled.

Onboard LAN Option ROM Select

Select iSCSI to use the iSCSI Option ROM to boot the computer using a network device. Select PXE (Preboot Execution Environment) to use an PXE Option ROM to boot the computer using a network device. The options are iSCSI and **PXE**.

Load Onboard LAN1 Option ROM/Load Onboard LAN2 Option ROM

Select Enabled to enable the onboard LAN1 Option ROM~LAN2 Option ROM. This is to boot the computer using a network device. The default setting for LAN1 Option ROM is **Enabled**, and the default setting for LAN2 Option ROM is **Disabled**.

VGA Priority

This feature allows the user to select the graphics adapter to be used as the primary boot device. The options are **Onboard**, and Offboard.

Network Stack

Select Enabled enable PXE (Preboot Execution Environment) or UEFI (Unified Extensible Firmware Interface) for network stack support. The options are Enabled and **Disabled**.

► Super IO Configuration

Super IO Chip: This item displays the Super IO chip used in the motherboard.

► Serial Port 1 Configuration

Serial Port

Select Enabled to enable a serial port specified by the user. The options are **Enabled** and Disabled.

Device Settings

This item displays the settings of Serial Port 1.

Change Settings

Use this feature to set the optimal Platform Environment Control Interface (PECI) setting for a serial port specified. The default setting is **Auto**, which will allow the AMI BIOS to automatically select the best Peci setting.

Device Mode

Use this feature to select the desired mode for a serial port specified. The options are **Normal** and High Speed.

► SOL Configuration

Serial Port

Select Enabled to enable a serial port specified by the user. The options are **Enabled** and Disabled.

Device Settings

This item displays the settings of the SOL Port.

Change Settings

Use this feature to set the optimal Platform Environment Control Interface (PECI) setting for a serial port specified. The default setting is **Auto**, which will allow the AMI BIOS to automatically select the best Peci setting.

Serial Port Attribute

Use this feature to select the attribute for this serial port. The options are **SOL** (Serial On LAN), and COM.

Device Mode

Use this feature to select the desired mode for a serial port specified. The options are **Normal** and High Speed.

► Serial Port Console Redirection

COM 1/SOL

These two submenus allow the user to configure the following Console Redirection settings for a COM Port specified by the user.

Console Redirection

Select Enabled to use a COM Port selected by the user for Console Redirection. The options are Enabled and Disabled. The default setting for COM1 is **Disabled**, and for SOL is **Enabled**.

► Console Redirection Settings

This feature allows the user to specify how the host computer will exchange data with the client computer, which is the remote computer used by the user.

Terminal Type

This feature allows the user to select the target terminal emulation type for Console Redirection. Select VT100 to use the ASCII Character set. Select VT100+ to add color and function key support. Select ANSI to use the Extended ASCII Character Set. Select VT-UTF8 to use UTF8 encoding to map Unicode characters into one or more bytes. The options are ANSI, VT100, **VT100+**, and VT-UTF8.

Bits Per second

Use this feature to set the transmission speed for a serial port used in Console Redirection. Make sure that the same speed is used in the host computer and the client computer. A lower transmission speed may be required for long and busy lines. The options are 9600, 19200, 38400, 57600 and **115200** (bits per second).

Data Bits

Use this feature to set the data transmission size for Console Redirection. The options are 7 Bits and **8 Bits**.

Parity

A parity bit can be sent along with regular data bits to detect data transmission errors. Select Even if the parity bit is set to 0, and the number of 1's in data bits is even. Select Odd if the parity bit is set to 0, and the number of 1's in data bits

is odd. Select None if you do not want to send a parity bit with your data bits in transmission. Select Mark to add a mark as a parity bit to be sent along with the data bits. Select Space to add a Space as a parity bit to be sent with your data bits. The options are **None**, Even, Odd, Mark and Space.

Stop Bits

A stop bit indicates the end of a serial data packet. Select 1 Stop Bit for standard serial data communication. Select 2 Stop Bits if slower devices are used. The options are **1** and **2**.

Flow Control

This feature allows the user to set the flow control for Console Redirection to prevent data loss caused by buffer overflow. Send a "Stop" signal to stop sending data when the receiving buffer is full. Send a "Start" signal to start sending data when the receiving buffer is empty. The options are **None** and Hardware RTS/CTS.

VT-UTF8 Combo Key Support

Select Enabled to enable VT-UTF8 Combination Key support for ANSI/VT100 terminals. The options are **Enabled** and Disabled.

Recorder Mode

Select Enabled to capture the data displayed on a terminal and send it as text messages to a remote server. The options are **Disabled** and Enabled.

Resolution 100x31

Select Enabled for extended-terminal resolution support. The options are Disabled and **Enabled**.

Legacy OS Redirection Resolution

Use this feature to select the number of rows and columns used in Console Redirection for legacy OS support. The options are 80x24 and **80x25**.

Putty KeyPad

This feature selects Function Keys and KeyPad settings for Putty, which is a terminal emulator designed for the Windows OS. The options are **VT100**, LINUX, XTERMR6, SC0, ESCN, and VT400.

Serial Port for Out-of-Band Management/Windows Emergency Management Services (EMS)

The submenu allows the user to configure Console Redirection settings to support Out-of-Band Serial Port management.

Console Redirection

Select Enabled to use a COM Port selected by the user for Console Redirection. The options are **Enabled** and Disabled.

► Console Redirection Settings

This feature allows the user to specify how the host computer will exchange data with the client computer, which is the remote computer used by the user.

Out-of-Band Management Port

The feature selects a serial port used by the Microsoft Windows Emergency Management Services (EMS) to communicate with a remote server. The options are **COM1** and SOL.

Terminal Type

This feature allows the user to select the target terminal emulation type for Console Redirection. Select VT100 to use the ASCII character set. Select VT100+ to add color and function key support. Select ANSI to use the extended ASCII character set. Select VT-UTF8 to use UTF8 encoding to map Unicode characters into one or more bytes. The options are ANSI, VT100, **VT100+**, and VT-UTF8.

Bits Per Second

This item sets the transmission speed for a serial port used in Console Redirection. Make sure that the same speed is used in the host computer and the client computer. A lower transmission speed may be required for long and busy lines. The options are 9600, 19200, 57600, and **115200** (bits per second).

Flow Control

This feature allows the user to set the flow control for Console Redirection to prevent data loss caused by buffer overflow. Send a "Stop" signal to stop sending data when the receiving buffer is full. Send a "Start" signal to start sending data when the receiving buffer is empty. The options are **None**, Hardware RTS/CTS, and Software Xon/Xoff.

Data Bits, Parity, Stop Bits

The status of these features is displayed.

► ACPI Settings

Use this feature to configure Advanced Configuration and Power Interface (ACPI) power management settings for your system.

ACPI Sleep State

Use this feature to select the ACPI State when the system is in sleep mode. Select S1 (CPU_Stop_Clock) to erase all CPU caches and stop executing instructions. Power to the CPU(s) and RAM is maintained, but RAM is refreshed. Select Suspend Disabled to use power-reduced mode. Power will only be supplied to limited components (such as RAMs) to maintain the most critical functions of the system. The options are **S1 (CPU_Stop_Clock)** and Suspend Disabled.

NUMA (NON-Uniform Memory Access)

This feature enables the Non-Uniform Memory Access ACPI support. The options are **Enabled** and Disabled.

High Precision Event Timer

Select Enabled to activate the High Precision Event Timer (HPET) that produces periodic interrupts at a much higher frequency than a Real-time Clock (RTC) does in synchronizing multimedia streams, providing smooth playback, reducing the dependency on other timestamp calculation devices, such as an x86 RDTSC Instruction embedded in the CPU. The High Performance Event Timer is used to replace the 8254 Programmable Interval Timer. The options are **Enabled** and Disabled.

► Trusted Computing (Available when a TPM device is detected by the BIOS)

Configuration

TPM Support

Select Enabled on this item and enable the TPM jumper on the motherboard to enable TPM support to improve data integrity and network security. The options are **Enabled** and Disabled.

TPM State

Select Enabled to enable TPM security settings to improve data integrity and network security. The options are **Disabled** and Enabled.

Pending Operation: This item displays the status of a pending operation.

Current Status Information: This item displays the information regarding the current TPM status.

TPM Enable Status

This item displays the status of TPM Support to indicate if TPM is currently enabled or disabled.

TPM Active Status

This item displays the status of TPM Support to indicate if TPM is currently active or deactivated.

TPM Owner Status

This item displays the status of TPM Ownership.

► Intel TXT (LT-SX) Configuration**Intel TXT (LT-SX) Hardware Support**

This feature indicates if the following hardware components support the Intel Trusted Execution Technology.

CPU: TXT (Trusted Execution Technology) Feature

Chipset: TXT (Trusted Execution Technology) Feature

Intel TXT (LT-SX) Configuration

This feature displays the following TXT configuration setting.

TXT (LT-SX) Support: This item indicates if the Intel TXT support is enabled or disabled.

Intel TXT (LT-SX) Dependencies

This feature displays the features that need to be enabled for the Intel Trusted Execution Technology to work properly in the system.

VT-d Support: Intel Virtualization Technology with Direct I/O support

VT Support: Intel Virtualization Technology support

TPM Support: Trusted Platform support

TPM State: Trusted Platform state

► ME Subsystem

This feature displays the following ME Subsystem Configuration settings.

- **ME BIOS Interface Version**
- **ME Version**

iSCSI Configuration: This item displays iSCSI configuration information:

iSCSI Initiator Name

This item displays the name of the iSCSI Initiator, which is a unique name used in the world. The name must use IQN format. The following actions can also be performed:

- Add an Attempt

- Delete Attempts
 - Commit Changes and Exit
 - Discard Changes and Exit

- Change Attempt Order
 - Commit Changes and Exit
 - Discard Changes and Exit

Intel® I350 Gigabit Network Connections: These items display the following information on the Intel I350 LAN connections.

► NIC Configuration

Link Speed

Use this feature to change the link speed and duplex for the current port. The options are **AutoNeg**, 10Mbps Half, 10Mbps Full, 100Mbps Half, and 100Mbps full.

Wake on LAN

Select enabled to wake the system with a magic packet. The options are Enabled and **Disabled**.

Blink LEDs

This feature allows the user to specify the duration for LEDs to blink. The range is from 0 ~ 15 seconds. The default setting is **0**.

PORT CONFIGURATION INFORMATION

This section displays the following port information:

- UEFI Driver

- Adapter PBA

- Chip Type
- PCI Device ID
- PCI Bus:Device:Function
- Link Status
- Factory MAC Address
- Alternate MAC Address

7-4 Event Logs

Select the Event Logs tab to access the following submenu items.

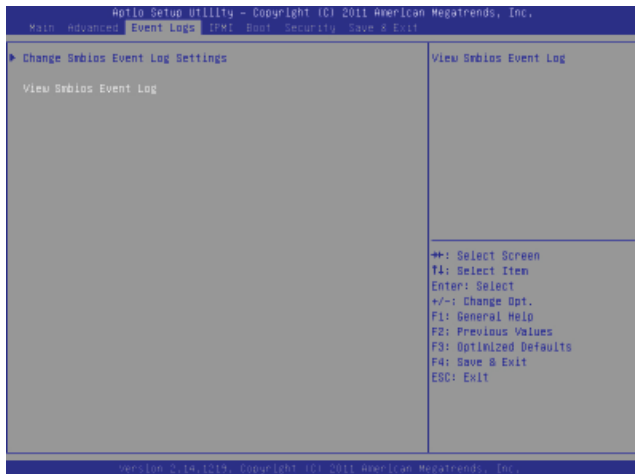

► Change SMBIOS Event Log Settings

This feature allows the user to configure SMBIOS Event settings.

Enabling/Disabling Options

SMBIOS Event Log

Select Enabled to enable SMBIOS (System Management BIOS) Event Logging during system boot. The options are **Enabled** and Disabled.

Runtime Error Logging Support

Select Enabled to support Runtime Error Logging. The options are **Enabled** and Disabled.

Memory Correctable Error Threshold

This feature allows the user to enter the threshold value for correctable memory errors. The default setting is **10**.

PCI Error Logging Support

Select Enabled to support error event logging for PCI slots. The options are Enabled and **Disabled**.

Erasing Settings**Erase Event Log**

Select Enabled to erase the SMBIOS (System Management BIOS) Event Log, which is completed before a event logging is initialized upon system reboot. The options are **No** and Yes.

When Log is Full

Select Erase Immediately to immediately erase SMBIOS error event logs that exceed the limit when the SMBIOS event log is full. Select Do Nothing for the system to do nothing when the SMBIOS event log is full. The options are **Do Nothing** and Erase Immediately.

SMBIOS Event Log Standard Settings**Log System Boot Event**

Select Enabled to log system boot events. The options are **Disabled** and Enabled.

MECI (Multiple Event Count Increment)

Enter the increment value for the multiple event counter. Enter a number between 1 to 255. The default setting is **1**.

METW (Multiple Event Count Time Window)

This item allows the user to decide how long (in minutes) should the multiple event counter wait before generating a new event log. Enter a number between 0 to 99. The default setting is **60**.

View SMBIOS Event Log

This item allows the user to view the event in the SMBIOS event log. Select this item and press <Enter> to view the status of an event in the log.

Date/Time/Error Code/Severity

View System Event Log

This item allows the user to view the event in the system event log. Select this item and press <Enter> to view the status of an event in the log.

Date/Time/Error Code/Severity

7-5 IPMI

Select the IPMI (Intelligent Platform Management Interface) tab to access the following submenu items.

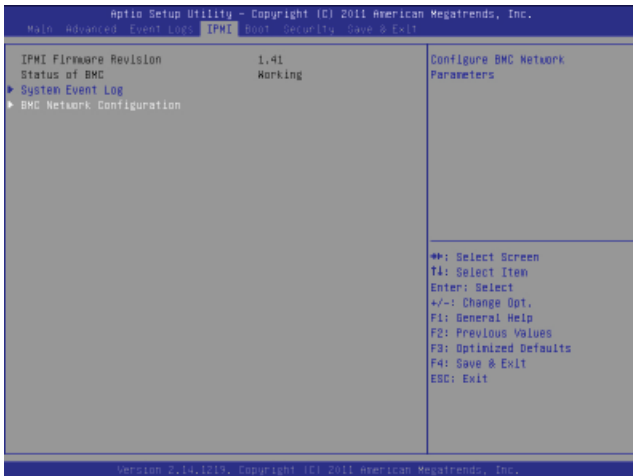

IPMI Firmware Revision

This item indicates the IPMI firmware revision used in your system.

IPMI Status

This item indicates the status of the IPMI firmware installed in your system.

► System Event Log

Enabling/Disabling Options

SEL Components

Select Enabled for all system event logging at bootup. The options are **Enabled** and Disabled.

Erasing Settings

Erase SEL

Select Yes, On next reset to erase all system event logs upon next system reboot. Select Yes, On every reset to erase all system event logs upon each system reboot. Select No to keep all system event logs after each system reboot. The options are **No**, Yes, On next reset, and Yes, On every reset.

When SEL is Full

This feature allows the user to decide what the BIOS should do when the system event log is full. Select Erase Immediately to erase all events in the log when the system event log is full. The options are **Do Nothing** and Erase Immediately.

Custom EFI Logging Options

Log EFI Status Codes

Select Enabled to log EFI (Extensible Firmware Interface) Status Codes, Error Codes or Progress Codes. The options are **Enabled** and Disabled.



Note: After making changes on a setting, be sure to reboot the system for the changes to take effect.

►BMC Network Configuration

LAN Channel 1: This feature allows the user to configure the settings for LAN1 Port.

Update IPMI LAN Configuration

This feature allows the user to decide if the BIOS should configure the IPMI setting at next system boot. The options are **No** and Yes. If the option is set to Yes, the user is allow to configure the IPMI settings at next system boot:

Configuration Address Source

This feature allows the user to select the source of the IP address for this computer. If Static is selected, you will need to know the IP address of this computer and enter it to the system manually in the field. If DHCP is selected, the BIOS will search for a DHCP (Dynamic Host Configuration Protocol) server in the network that is attached to and request the next available IP address for this computer. The options are **DHCP** and Static. The following items are assigned IP addresses automatically if DHCP is selected, or can be configured manually if Static is selected.

Station IP Address

This item displays the Station IP address for this computer. This should be in decimal and in dotted quad form (i.e., 192.168.10.253).

Subnet Mask

This item displays the sub-network that this computer belongs to. The value of each three-digit number separated by dots should not exceed 255.

Station MAC Address

This item displays the Station MAC address for this computer. Mac addresses are 6 two-digit hexadecimal numbers.

Gateway IP Address

This item displays the Gateway IP address for this computer. This should be in decimal and in dotted quad form (i.e., 192.168.10.253).

7-6 Boot

This submenu allows the user to configure the following boot settings for the system.

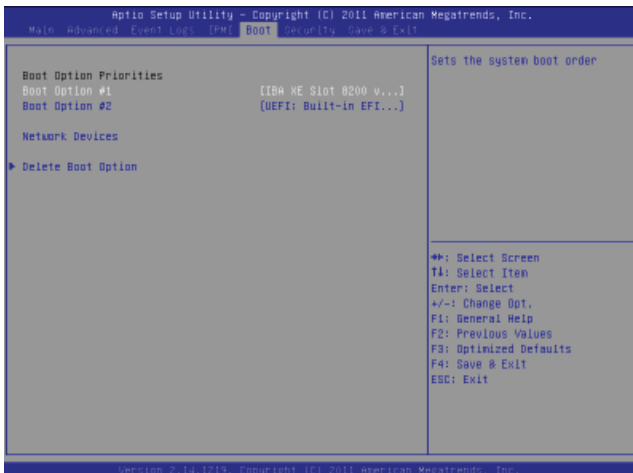

Boot Option Priorities

Boot Option #1/ Boot Option #2/ Boot Option #3, etc.

Use this feature to specify the sequence of boot device priority.

Network Devices

Use these options to set the order of the legacy network, USB, and Hard Disk Drive devices detected by the motherboard.

►Delete Boot Option

This feature allows the user to select a EFI boot device to delete from the boot priority list.

Delete Boot Option

Select the desired boot device to delete.

7-7 Security

This menu allows the user to configure the following security settings for the system.



Administrator Password

Use this feature to set the Administrator Password which is required to enter the BIOS setup utility. The length of the password should be from 3 characters to 8 characters long.

User Password

Use this feature to set a User Password which is required to log into the system and to enter the BIOS setup utility. The length of the password should be from 3 characters to 8 characters long.

7-8 Save & Exit

This submenu allows the user to configure the Save and Exit settings for the system.

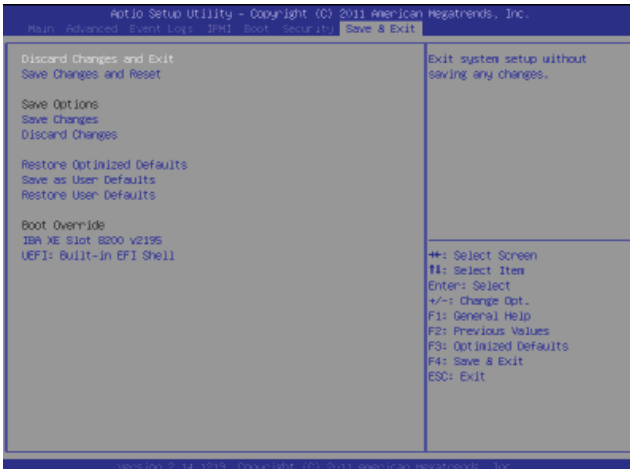

Discard Changes and Exit

Select this option to quit the BIOS Setup without making any permanent changes to the system configuration, and reboot the computer. Select Discard Changes and Exit, and press <Enter>. When the dialog box appears, asking you if you want to exit the BIOS setup without saving, click **Yes** to quit BIOS without saving the changes, or click No to quit the BIOS and save changes.

Save Changes and Reset

When you have completed the system configuration changes, select this option to save the changes and reboot the computer so that the new system configuration settings can take effect. Select Save Changes and Exit, and press <Enter>. When the dialog box appears, asking you if you want to exit the BIOS setup without saving, click **Yes** to quit BIOS without saving the changes, or click No to quit the BIOS and save changes.

Save Options

Save Changes

Select this option and press <Enter> to save all changes you've done so far and return to the AMI BIOS utility Program. When the dialog box appears, asking you if you want to save configuration, click **Yes** to save the changes, or click No to return to the BIOS without making changes.

Discard Changes

Select this feature and press <Enter> to discard all the changes and return to the BIOS setup. When the dialog box appears, asking you if you want to load previous values, click **Yes** to load the values previous saved, or click No to keep the changes you've made so far.

Restore Optimized Defaults

Select this feature and press <Enter> to load the optimized default settings that help optimize system performance. When the dialog box appears, asking you if you want to load optimized defaults, click **Yes** to load the optimized default settings, or click No to abandon optimized defaults.

Save as User Defaults

Select this feature and press <Enter> to save the current settings as the user's defaults. When the dialog box appears, asking you if you want to save values as user's defaults, click **Yes** to save the current values as user's default settings, or click No to keep the defaults previously saved as the user's defaults.

Restore User Defaults

Select this feature and press <Enter> to load the user's defaults previously saved in the system. When the dialog box appears, asking you if you want to restore user's defaults, click **Yes** to restore the user's defaults previously saved in the system, or click No to abandon the user's defaults that were previously saved.

Boot Override

This feature allows the user to override the Boot Option Priorities setting in the Boot menu, and instead boot the system with one of the listed devices.

Appendix A

BIOS Error Beep Codes

During the POST (Power-On Self-Test) routines, which are performed at each system boot, errors may occur.

Non-fatal errors are those which, in most cases, allow the system to continue to boot. The error messages normally appear on the screen.

Fatal errors will not allow the system to continue with bootup procedure. If a fatal error occurs, you should consult with your system manufacturer for possible repairs.

These fatal errors are usually communicated through a series of audible beeps. The numbers on the fatal error list correspond to the number of beeps for the corresponding error.

BIOS Error Beep Codes		
Beep Code/LED	Error Message	Description
1 beep	Refresh	Ready to boot
5 short beeps + 1 long beep	Memory error	No memory detected in the system
5 beeps	No Con-In or No Con-Out devices	Con-In: USB or PS/2 keyboard, PCI or Serial Console Redirection, IPMI KVM or SOL Con-Out: Video Controller, PCI or Serial Console Redirection, IPMI SOL
X9 IPMI Error Codes		
1 Continuous Beep	System OH	System Overheat

Notes

Appendix B

System Specifications

Processors

Two Intel Xeon E5-2600 series processors

Note: Please refer to our web site for a complete listing of supported processors.

Chipset

Intel C602

BIOS

32 Mb AMIBIOS® SPI Flash ROM

Memory Capacity

Eight DIMM sockets supporting up to 256 GB of registered ECC DDR3-1600/1333/1066/800 MHz RDIMMs

Note: See the memory section in Chapter 5 for details.

GPUs (Graphics Processing Units)

A total of four GPUs are supported (true PCI-E 3.0 x16 signal)

SATA Controller

Intel on-chip controller for 10 SATA ports (RAID 0, 1, 5 and 10)

Drive Bays

Four 2.5" hot-swap drive bays to house SATA drives

Expansion Slots

One PCI-E 3.0 x8 card (in x16 slot) with the use of included riser card

Serverboard

X9DRG-HF/X9DRG-HTF (proprietary ATX form factor)

Dimensions: 19.7" x 9.2" (500.4 x 233.7 mm)

Chassis

SC118GQTS-1800GBP (1U rackmount)

Dimensions: (WxHxD) 17.2 x 1.7 x 28.2 in. (437 x 43 x 716 mm)

System Cooling

Twelve sets of 4-cm counter-rotating cooling fans (fan speed controlled by BIOS setting)

System Input Requirements

AC Input Voltage: 100-240 VAC

Rated Input Current: 1000W: 100-120V/12-10A, 1200W: 120-140V/12-10A, 1800W: 200-240V/10-8.5A

Rated Input Frequency: 50-60 Hz

Power Supply

Rated Output Power: 1800W (Part# PWS-1K81P-1R)

Rated Output Voltages: +12V (150A), +5Vsb (4A)

Operating Environment

Operating Temperature: 10° to 35° C (50° to 95° F)

Non-Operating Temperature: -40° to 70° C (-40° to 158° F)

Operating Relative Humidity: 8% to 90% (non-condensing)

Non-Operating Relative Humidity: 5 to 95% (non-condensing)

Regulatory Compliance

Electromagnetic Emissions: FCC Class A, EN 55022 Class A, EN 61000-3-2/-3-3, CISPR 22 Class A

Electromagnetic Immunity: EN 55024/CISPR 24, (EN 61000-4-2, EN 61000-4-3, EN 61000-4-4, EN 61000-4-5, EN 61000-4-6, EN 61000-4-8, EN 61000-4-11)

Safety: CSA/EN/IEC/UL 60950-1 Compliant, UL or CSA Listed (USA and Canada), CE Marking (Europe)

California Best Management Practices Regulations for Perchlorate Materials: This Perchlorate warning applies only to products containing CR (Manganese Dioxide) Lithium coin cells. "Perchlorate Material-special handling may apply. See www.dtsc.ca.gov/hazardouswaste/perchlorate"

(continued from front)

The products sold by Supermicro are not intended for and will not be used in life support systems, medical equipment, nuclear facilities or systems, aircraft, aircraft devices, aircraft/emergency communication devices or other critical systems whose failure to perform be reasonably expected to result in significant injury or loss of life or catastrophic property damage. Accordingly, Supermicro disclaims any and all liability, and should buyer use or sell such products for use in such ultra-hazardous applications, it does so entirely at its own risk. Furthermore, buyer agrees to fully indemnify, defend and hold Supermicro harmless for and against any and all claims, demands, actions, litigation, and proceedings of any kind arising out of or related to such ultra-hazardous use or sale.

Notes