

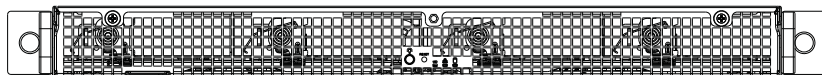

Microserver  
K1048-RT



USER'S MANUAL

Revision 1.0c

The information in this User's Manual has been carefully reviewed and is believed to be accurate. The vendor assumes no responsibility for any inaccuracies that may be contained in this document, makes no commitment to update or to keep current the information in this manual, or to notify any person or organization of the updates. **Please Note: For the most up-to-date version of this manual, please see our web site at [www.supermicro.com](http://www.supermicro.com).**

Super Micro Computer, Inc. ("Supermicro") reserves the right to make changes to the product described in this manual at any time and without notice. This product, including software and documentation, is the property of Supermicro and/or its licensors, and is supplied only under a license. Any use or reproduction of this product is not allowed, except as expressly permitted by the terms of said license.

IN NO EVENT WILL SUPERMICRO BE LIABLE FOR DIRECT, INDIRECT, SPECIAL, INCIDENTAL, SPECULATIVE OR CONSEQUENTIAL DAMAGES ARISING FROM THE USE OR INABILITY TO USE THIS PRODUCT OR DOCUMENTATION, EVEN IF ADVISED OF THE POSSIBILITY OF SUCH DAMAGES. IN PARTICULAR, SUPERMICRO SHALL NOT HAVE LIABILITY FOR ANY HARDWARE, SOFTWARE, OR DATA STORED OR USED WITH THE PRODUCT, INCLUDING THE COSTS OF REPAIRING, REPLACING, INTEGRATING, INSTALLING OR RECOVERING SUCH HARDWARE, SOFTWARE, OR DATA.

Any disputes arising between manufacturer and customer shall be governed by the laws of Santa Clara County in the State of California, USA. The State of California, County of Santa Clara shall be the exclusive venue for the resolution of any such disputes. Super Micro's total liability for all claims will not exceed the price paid for the hardware product.

FCC Statement: This equipment has been tested and found to comply with the limits for a Class A digital device pursuant to Part 15 of the FCC Rules. These limits are designed to provide reasonable protection against harmful interference when the equipment is operated in a commercial environment. This equipment generates, uses, and can radiate radio frequency energy and, if not installed and used in accordance with the manufacturer's instruction manual, may cause harmful interference with radio communications. Operation of this equipment in a residential area is likely to cause harmful interference, in which case you will be required to correct the interference at your own expense.

California Best Management Practices Regulations for Perchlorate Materials: This Perchlorate warning applies only to products containing CR (Manganese Dioxide) Lithium coin cells. "Perchlorate Material-special handling may apply. See [www.dtsc.ca.gov/hazardouswaste/perchlorate](http://www.dtsc.ca.gov/hazardouswaste/perchlorate)"

**WARNING: Handling of lead solder materials used in this product may expose you to lead, a chemical known to the State of California to cause birth defects and other reproductive harm.**

Manual Revision 1.0c  
Release Date: June 23, 2016

Unless you request and receive written permission from Super Micro Computer, Inc., you may not copy any part of this document.

Information in this document is subject to change without notice. Other products and companies referred to herein are trademarks or registered trademarks of their respective companies or mark holders.

Copyright © 2016 by Super Micro Computer, Inc.  
All rights reserved.

**Printed in the United States of America**

## Preface

### About This Manual

This manual is written for professional system integrators and PC technicians. It provides information for the installation and use of the K1048-RT. Installation and maintenance should be performed by experienced technicians only.

The K1048-RT is a high-end Microserver unit based on the SC801LTS-R406KP 1U rackmount server chassis, a dual 10G Broadcom BMC-53347 LAN switch and twelve (12) internal hot-swap Ethernet 3.5" HDD drives. The K1048-RT has an IPMI LAN port, two 10G LAN ports, a serial management port and two redundant 400 Watt power supplies.

### Manual Organization

#### **Chapter 1: Introduction**

The first chapter provides a checklist of the main components included with the server system and describes the main features of the mainboard and the SC801LTS-R406KP chassis.

#### **Chapter 2: Server Installation**

This chapter describes the steps necessary to install the Microserver K1048-RT into a rack and check out the configuration prior to powering up the system.

#### **Chapter 3: System Interface**

Refer here for details on the system interface, which includes the functions and information provided by the control panel on the chassis as well as other LEDs located throughout the system.

#### **Chapter 4: System Safety**

You should thoroughly familiarize yourself with this chapter for a general overview of safety precautions that should be followed when installing and servicing the Microserver K1048-RT.

#### **Chapter 5: Advanced Serverboard Setup**

Chapter 5 provides detailed information on the mainboard, including the locations and functions of connections, headers and jumpers.

## **Chapter 6: Advanced Chassis Setup**

Refer to Chapter 6 for detailed information on the SC801LTS-R406KP server chassis. You should follow the procedures given in this chapter when installing, removing, or reconfiguring drives and when replacing system power supply units and cooling fans.

## **Appendix A: System Specifications**

## **Appendix B: Storage Monitoring IPMI Page**

## Notes

# Table of Contents

## **Chapter 1 Introduction**

1-1	Overview .....	1-1
1-2	Server and Switch Features .....	1-2
	Microserver Storage System.....	1-2
	Ethernet Ports .....	1-2
	Onboard Controllers/Ports .....	1-3
	Other Features .....	1-3
1-3	Server Chassis Features .....	1-3
	System Power .....	1-3
	Microserver Disk Subsystem.....	1-3
	Front Control Panel.....	1-4
	I/O Ports .....	1-4
	Cooling System .....	1-4
	Mounting Rails .....	1-4
1-4	Contacting Supermicro.....	1-6

## **Chapter 2 Server Installation**

2-1	Overview .....	2-1
2-2	Unpacking the System .....	2-1
2-3	Preparing for Setup .....	2-1
	Choosing a Setup Location.....	2-2
2-4	Warnings and Precautions .....	2-2
	Rack Precautions .....	2-2
	Server Precautions.....	2-2
	Rack Mounting Considerations .....	2-3
	Ambient Operating Temperature .....	2-3
	Reduced Airflow .....	2-3
	Mechanical Loading .....	2-3
	Circuit Overloading.....	2-3
	Reliable Ground .....	2-4
2-5	Installing the System into a Rack .....	2-4
	Sliding the Chassis onto the Rack Rails.....	2-6
2-6	Power-up/Power-down Sequence.....	2-7

---

---

**Chapter 3 System Interface**

3-1	Overview .....	3-1
3-2	Control Panel Buttons .....	3-2
3-3	Control Panel LEDs .....	3-2

**Chapter 4 Standardized Warning Statements for AC Systems**

4-1	About Standardized Warning Statements .....	4-1
	Warning Definition .....	4-1
	Installation Instructions .....	4-4
	Circuit Breaker .....	4-5
	Power Disconnection Warning .....	4-6
	Equipment Installation .....	4-8
	Restricted Area .....	4-9
	Battery Handling .....	4-10
	Redundant Power Supplies .....	4-12
	Backplane Voltage .....	4-13
	Comply with Local and National Electrical Codes .....	4-14
	Product Disposal .....	4-15
	Hot Swap Fan Warning .....	4-16
	Power Cable and AC Adapter .....	4-18

**Chapter 5 Microserver System Setup**

5-1	Rear I/O Ports .....	5-1
5-2	Mainboard Details .....	5-2
5-3	Connector Definitions .....	5-3
5-4	Onboard Indicators .....	5-4
5-5	System Battery .....	5-5

**Chapter 6 Advanced Chassis Setup**

6-1	Static-Sensitive Devices .....	6-1
	Precautions .....	6-1
6-2	Removing the Power Cord .....	6-2
6-3	Control Panel .....	6-2
6-4	Removing the Chassis Cover .....	6-3
6-5	Installing and Replacing Hard Drives .....	6-4
6-6	System Fans .....	6-7
6-7	Power Supply .....	6-8

**Appendix A System Specifications**

**Appendix B Storage Monitoring IPMI Page**

Using the IPMI Screen.....	B-1
I2C Commands .....	B-2
OEM IPMI Commands to Get Ethernet Hard Drive Information.....	B-2
Standards .....	B-2
Byte Range.....	B-3
IP Address .....	B-4
MAC Address .....	B-5

# Chapter 1

## Introduction

### 1-1 Overview

The K1048-RT Microserver is a high-end switch/storage server comprised of three main subsystems: the SC801LTS-R406KP 1U server chassis the Broadcom BMC-53347 switch system and twelve (12) 3.5" Ethernet hard drives. Please refer to our web site for information on operating systems that have been certified for use with the system ([www.supernmicro.com](http://www.supernmicro.com)).

An illustration of the overview IP assignment flow for this switch/storage server is shown below.

Figure 1-1. Overview IP Assignment Flow

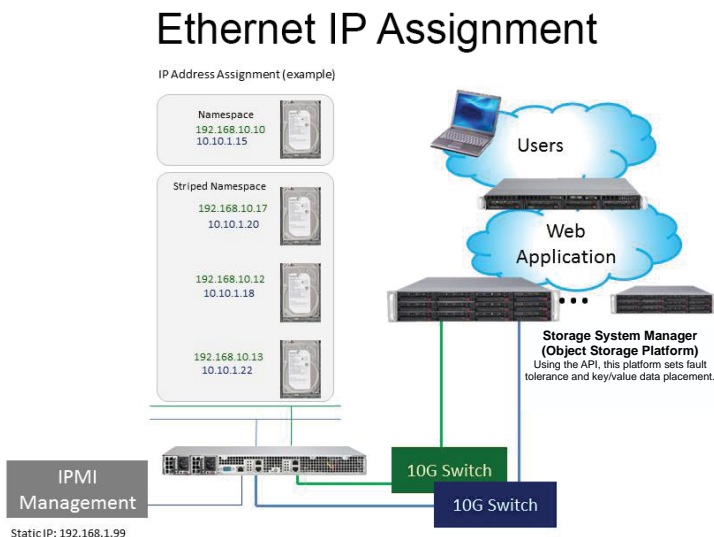

In addition to the system mainboard and chassis, various hardware components have been included with the K1048-RT server, as listed below:

- Six (6) 40x28-mm 13K RPM 4-pin PWM fans (FAN-0065L4)
- One (1) 85-cm 16-pin to 16-pin ribbon 28AWG front control cable (CBL-CDAT-0648)
- Two (2) 8-pin to 3 2x2(10-cm) power cable for SC801L (CBL-PWEX-0636)

- HDD Components:  
Twelve (12) hot-swap 3.5" 4TB 5.9K RPM 64MB Cache, Ethernet HDD's (HDD-T4000-ST4000NK000101)
- One (1) rails set (MCP-290-00066-0N)

**Note:** For your system to work properly, please follow the links below to download all necessary drivers/utilities and the user's manual for your server.

- Supermicro product manuals: <http://www.supermicro.com/support/manuals/>
- Product drivers and utilities: <ftp://ftp.supermicro.com>
- Product safety information:  
[http://super-dev/about/policies/safety\\_information.cfm](http://super-dev/about/policies/safety_information.cfm)
- If you have any questions, please contact our support team at:  
[support@supermicro.com](mailto:support@supermicro.com)

## 1-2 Server and Switch Features

At the heart of the K1048-RT server/switch lies dual Broadcom™ BMC-53347 10Gbps communication chips and system for communicating and servicing the Ethernet hard-disk drives. Although these systems are mounted on a system mainboard, this mainboard does not contain any CPUs, chipset or memory and therefore will not be covered in this manual.

The sections below cover the main server and switch features of the K1048-RT system (see Figure 1-1 for a block diagram of the chipset).

### Microserver Storage System

The K1048-RT system ships fully integrated with twelve (12) dual ported 4TB 7200-rpm Ethernet drives (48TB). Redundant 1G Ethernet downstream connections allow for resilient multi-path access to the key/value pair HTTP storage interface built into each drive.

### Ethernet Ports

Two Broadcom BMC-53347 10-Gigabit (1/10 Gbps) Ethernet Controllers are integrated into the mainboard in the K1048-RT server. Additionally an IPMI LAN port is provided. The system's AST2400BMC (Baseboard Management Control) chip supports IPMI 2.0.

## Onboard Controllers/Ports

The K1048-RT system contains the following I/O ports: four 10G Ethernet ports and one IPMI LAN. The system's mainboard supports up to twelve (12) Ethernet drives.

Note: The default IP Address for the system is **192.168.1.99**.

## Other Features

Other onboard features for the system include the following:

- Redundant I2C connection for status/polling of media
- Controls to optimize power utilization
- Out of band system management with IPMI 2.0 GUI or *ipmitools* software
- Persistent drive bay position/enumeration
- HDD IP address assignment (DHCP is default)

For details on IPMI software and resources go to the SuperMicro website at [www.supermicro.com](http://www.supermicro.com) or see <http://www.supermicro.com/solutions/ManagementSoftware.cfm> for more details.

## 1-3 Server Chassis Features

The following is a general outline of the main features of the SC801 server chassis.

### System Power

Each SC801 chassis model includes a high-efficiency 94% or 95+% Platinum certified power supply, rated at 400 Watts plus one redundant backup power supply. In the unlikely event your power supply fails, replacement is simple and can be accomplished without tools.

**Note:** The power supplies are both redundant, hot-plug.

### Microserver Disk Subsystem

The SC801 features twelve (12) 3.5" Ethernet drives mounted in the chassis. These drives are hot-swappable units and are connected to the system by cables that provide power and dual-ported Ethernet access. By default the drives are configured for DHCP (two addresses, one per port). Static assignment is supported through the IPMI interface.

## Front Control Panel

All SC801 models includes a front panel control panel on the front of the chassis. The control panel on the K1048-RT server provides you with system monitoring and power control. LEDs indicate system power, HDD activity, network activity, system overheat and power supply failure. A main power button and a system reset button are also included.

## I/O Ports

The SC801 chassis designed to be used in a 1U rackmount configuration. The SC801 chassis provides four 1/10G Ethernet using RJ45 copper connectors and an IPMI Ethernet port in the rear of the chassis.

## Cooling System

The SC801 chassis accepts six (6) 8-cm system fans, which are powered from the system.

**Note:** The fans in this system are NOT redundant, hot-plug.

## Mounting Rails

The SC801 includes a set of quick-release rails, and can be placed in a rack for secure storage and use. To setup your rack, follow the step-by-step instructions included in this manual.

**Figure 1-1. Chipset:  
System Block Diagram**

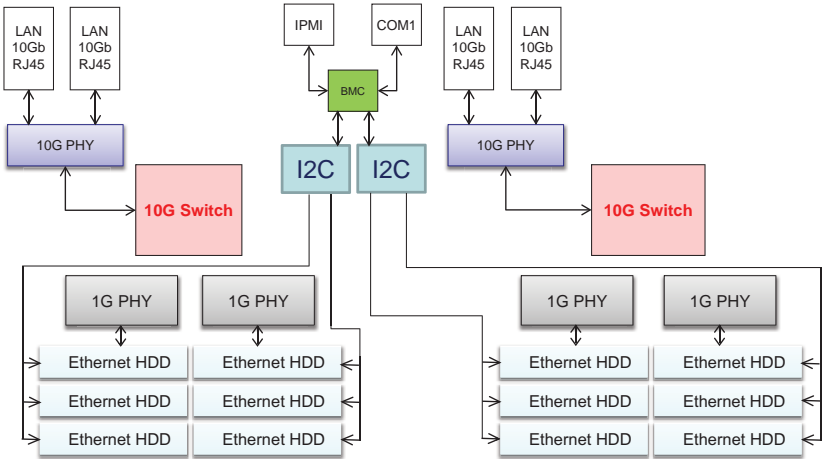

**Note:** This is a general block diagram. All 12 drives are physically connected to both switches.

## 1-4 Contacting Supermicro

### Headquarters

Address: Super Micro Computer, Inc.  
980 Rock Ave.  
San Jose, CA 95131 U.S.A.

Tel: +1 (408) 503-8000

Fax: +1 (408) 503-8008

Email: [marketing@supermicro.com](mailto:marketing@supermicro.com) (General Information)  
[support@supermicro.com](mailto:support@supermicro.com) (Technical Support)

Website: [www.supermicro.com](http://www.supermicro.com)

### Europe

Address: Super Micro Computer B.V.  
Het Sterrenbeeld 28, 5215 ML  
's-Hertogenbosch, The Netherlands

Tel: +31 (0) 73-6400390

Fax: +31 (0) 73-6416525

Email: [sales@supermicro.nl](mailto:sales@supermicro.nl) (General Information)  
[support@supermicro.nl](mailto:support@supermicro.nl) (Technical Support)  
[rma@supermicro.nl](mailto:rma@supermicro.nl) (Customer Support)

Website: [www.supermicro.com](http://www.supermicro.com)

### Asia-Pacific

Address: Super Micro Computer, Inc.  
3F, No. 150, Jian 1st Rd.  
Zhonghe Dist., New Taipei City 235  
Taiwan (R.O.C)

Tel: +886-(2) 8226-3990

Fax: +886-(2) 8226-3992

Email: [support@supermicro.com.tw](mailto:support@supermicro.com.tw)

Website: [www.supermicro.com.tw](http://www.supermicro.com.tw)

## Chapter 2

# Server Installation

### 2-1 Overview

This chapter provides a quick setup checklist to get your K1048-RT up and running. Following these steps in the order given should enable you to have the system operational within a minimum amount of time. This quick setup assumes that your system has come to you preinstalled with Ethernet Drives. If your system is not already fully integrated with a mainboard, processors, system memory etc., please turn to the chapter or section noted in each step for details on installing specific components.

### 2-2 Unpacking the System

You should inspect the box the K1048-RT server was shipped in and note if it was damaged in any way. If the server itself shows damage you should file a damage claim with the carrier who delivered it.

Decide on a suitable location for the rack unit that will hold the K1048-RT server. It should be situated in a clean, dust-free area that is well ventilated. Avoid areas where heat, electrical noise and electromagnetic fields are generated. You will also need it placed near a grounded power outlet. Read the Rack and Server Precautions in the next section.

### 2-3 Preparing for Setup

The box the K1048-RT was shipped in should include two sets of rail assemblies, two rail mounting brackets and the mounting screws you will need to install the system into the rack. Follow the steps in the order given to complete the installation process in a minimum amount of time. Please read this section in its entirety before you begin the installation procedure outlined in the sections that follow.

## Choosing a Setup Location

- Leave enough clearance in front of the rack to enable you to open the front door completely (~25 inches) and approximately 30 inches of clearance in the back of the rack to allow for sufficient airflow and ease in servicing.
- This product is for installation only in a Restricted Access Location (dedicated equipment rooms, service closets and the like).
- This product is not suitable for use with visual display work place devices according to §2 of the the German Ordinance for Work with Visual Display Units.

## 2-4 Warnings and Precautions

### Rack Precautions

- Ensure that the leveling jacks on the bottom of the rack are fully extended to the floor with the full weight of the rack resting on them.
- In single rack installation, stabilizers should be attached to the rack. In multiple rack installations, the racks should be coupled together.
- Always make sure the rack is stable before extending a component from the rack.
- You should extend only one component at a time - extending two or more simultaneously may cause the rack to become unstable.

### Server Precautions

- Review the electrical and general safety precautions in Chapter 4.
- Determine the placement of each component in the rack *before* you install the rails.
- Install the heaviest server components on the bottom of the rack first, and then work up.
- Use a regulating uninterruptible power supply (UPS) to protect the server from power surges, voltage spikes and to keep your system operating in case of a power failure.
- Allow any hot plug drives and power supply modules to cool before touching them.
- Always keep the rack's front door and all panels and components on the servers closed when not servicing to maintain proper cooling.

## Rack Mounting Considerations



**Warning!** To prevent bodily injury when mounting or servicing this unit in a rack, you must take special precautions to ensure that the system remains stable. The following guidelines are provided to ensure your safety:

- This unit should be mounted at the bottom of the rack if it is the only unit in the rack.
- When mounting this unit in a partially filled rack, load the rack from the bottom to the top with the heaviest component at the bottom of the rack.
- If the rack is provided with stabilizing devices, install the stabilizers before mounting or servicing the unit in the rack.

### ***Ambient Operating Temperature***

If installed in a closed or multi-unit rack assembly, the ambient operating temperature of the rack environment may be greater than the ambient temperature of the room. Therefore, consideration should be given to installing the equipment in an environment compatible with the manufacturer's maximum rated ambient temperature (T<sub>mra</sub>).

### ***Reduced Airflow***

Equipment should be mounted into a rack so that the amount of airflow required for safe operation is not compromised.

### ***Mechanical Loading***

Equipment should be mounted into a rack so that a hazardous condition does not arise due to uneven mechanical loading.

### ***Circuit Overloading***

Consideration should be given to the connection of the equipment to the power supply circuitry and the effect that any possible overloading of circuits might have on overcurrent protection and power supply wiring. Appropriate consideration of equipment nameplate ratings should be used when addressing this concern.

### **Reliable Ground**

A reliable ground must be maintained at all times. To ensure this, the rack itself should be grounded. Particular attention should be given to power supply connections other than the direct connections to the branch circuit (i.e. the use of power strips, etc.).

## **2-5 Installing the System into a Rack**

This section provides information on installing the chassis into a rack unit with the rails provided. There are a variety of rack units on the market, which may mean that the assembly procedure differs slightly. You should also refer to the installation instructions that came with the rack unit you are using.

**Note:** These rails will fit a rack between 27" and 38" deep.



**Warning:** Do not pick up the server with the front handles. They are designed to pull the system from a rack only.



**Stability Hazard:** The rack stabilizing mechanism must be in place, or the rack must be bolted to the floor before you slide the unit out for servicing. Failure to stabilize the rack can cause the rack to tip over.

**Figure 2-1. Identifying the Sections of the Rack Rails**

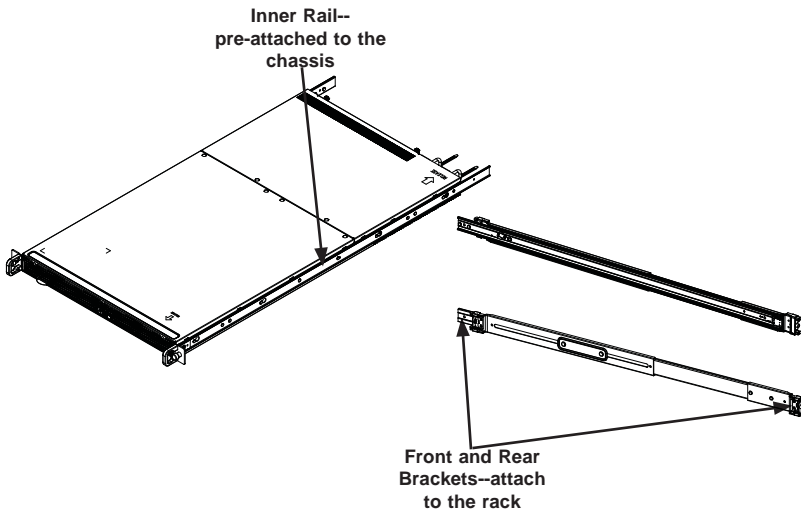

In order to install the rails onto the rack, refer to the illustration below.

Figure 2-2. Installing the Rails to the Chassis

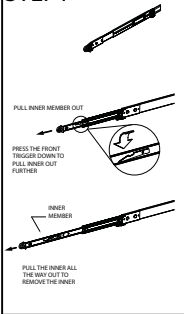
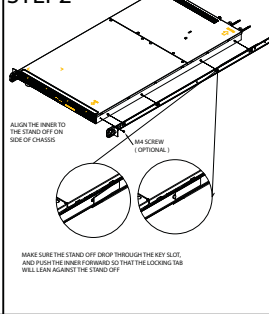
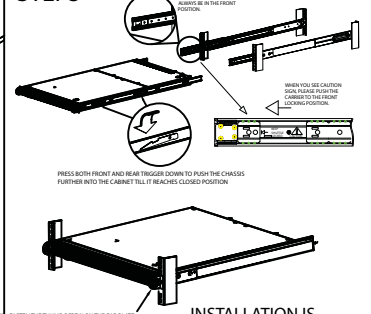
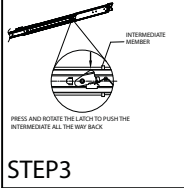
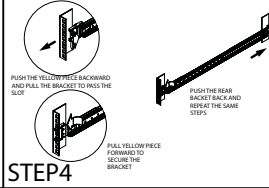
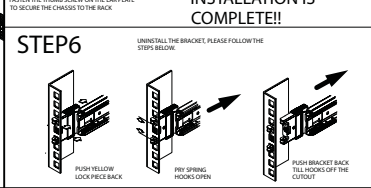
<p><b>REPON 1U SLIDE USER MANUAL</b></p>		<p><b>IMPORTANT NOTES:</b>          1. DO NOT SWAP RIGHT HAND INNER WITH LEFT HAND, VISE VERSA.          2. MOUNT INNER MEMBER TO CHASSIS WITH CARE, DO NOT WAVE OR DROP IT.</p>
<p><b>STEP 1</b></p>  <p>PULL INNER MEMBER OUT</p> <p>PRESS THE FRONT TRIGGER DOWN TO PULL INNER OUT FURTHER</p> <p>INNER MEMBER</p> <p>PULL THE INNER ALL THE WAY OUT TO REMOVE THE INNER</p>	<p><b>STEP 2</b></p>  <p>ALIGN THE INNER TO THE STAND OFF ON SIDE OF CHASSIS</p> <p>LOCK SCREW (OPTIONAL)</p> <p>MAKE SURE THE STAND OFF DROP THROUGH THE KEY SLOT, AND PUSH THE INNER FORWARD SO THAT THE LOCKING TAB WILL LEAN AGAINST THE STAND OFF</p>	<p><b>STEP 5</b></p>  <p>BEARING CARRIER SHALL ALWAYS BE IN THE FRONT POSITION</p> <p>WHEN YOU SEE CAUTION SIGN PLEASE PROTECT CHASSIS TO THE FRONT LOCKING POSITION</p> <p>PRESS BOTH FRONT AND REAR TRIGGERS DOWN TO PUSH THE CHASSIS FURTHER INTO THE CABINET TILL IT REACHES CLOSED POSITION</p> <p>FASTEN THE THUMB SCREW ON THE EAR PLATE TO SECURE THE CHASSIS TO THE RACK</p> <p><b>INSTALLATION IS COMPLETE!!</b></p>
<p><b>STEP 3</b></p>  <p>INTERMEDIATE MEMBER</p> <p>PRESS AND ROTATE THE LATCH TO PUSH THE INTERMEDIATE ALL THE WAY BACK</p>	<p><b>STEP 4</b></p>  <p>PUSH THE YELLOW PIECE BACKWARD AND PULL THE BRACKET TO PASS THE SLOT</p> <p>PULL YELLOW PIECE FORWARD TO SECURE THE BRACKET</p> <p>PUSH THE REAR BRACKET BACK AND REPEAT THE SAME STEPS</p>	<p><b>STEP 6</b></p>  <p>UNINSTALL THE BRACKET, PLEASE FOLLOW THE STEPS BELOW:</p> <p>PUSH YELLOW LOCKPIECE BACK</p> <p>PRY SPRING HOOKS OPEN</p> <p>PUSH BRACKET BACK TILL HOOKS OFF THE CUTOUT</p>

## Sliding the Chassis onto the Rack Rails

### *Installing the Chassis into a Rack*

1. Align the chassis rails with the front of the rack rails.
2. Slide the chassis rails into the rack rails, keeping the pressure even on both sides. The spring latch engages when the chassis is part way in. Push the server completely into the rack.
3. (*Optional*) Insert and tighten the thumbscrews that hold the front of the server to the rack.

**Figure 2-3. Installing the Server into a Rack**

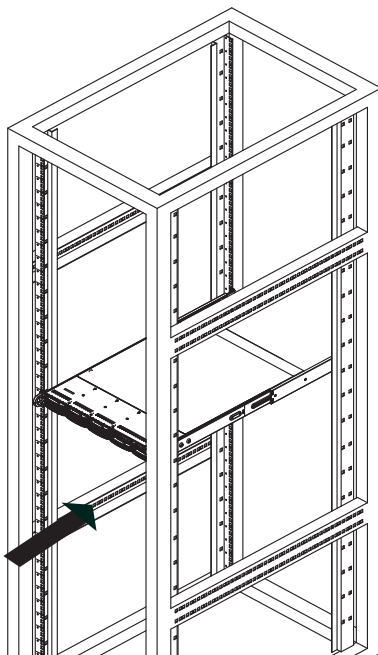

**Note:** The figure above is for illustrative purposes only. Always install servers at the bottom of the rack first.



**Warning:** Do not pick up the server with the front handles. They are designed to pull the system from a rack only.



**Stability hazard.** The rack stabilizing mechanism must be in place, or the rack must be bolted to the floor before you slide the unit out for servicing. Failure to stabilize the rack can cause the rack to tip over.

## 2-6 Power-up/Power-down Sequence

The K1048-RT system's power up/power-down sequences and indications are shown below.

<b>Powering-up the System</b>	
<b>Timing</b>	<b>Indications</b>
Plug the system into power source	PSU LED will light
Wait 30 Seconds	None
30 Seconds after power cord is plugged in	BMC ready/ onboard LED flashes (seen through air vent(chassis/ rear) Indicating the board management has booted successfully
Push-on Power button	Button LED turns green
Drives spin up, switch initializes *	Depending on environmental temperature Fans may not spin-up like a typical server power-up
~15-30 seconds after power button is pressed, Ethernet drives are available for DHCP address assignment on the redundant networks	Internal link LEDs are lit solid on the mainboard PHY indicators

\*Initial boot/spin-up may be silent.

<b>Powering Off the System</b>	
<b>Timing</b>	<b>Indications</b>
Hold power button for 6 seconds, then release	None
System shutdown will occur within seven seconds	Power button LED will go dark BMC remains powered on accessible until system is unplugged

# Notes

# Chapter 3

## System Interface

### 3-1 Overview

There are several LEDs on the control panel and on the drive carriers to keep you constantly informed of the overall status of the system. The chassis includes:

- A control panel on the front that includes power buttons and status monitoring lights
- Status lights for the power supply

Figure 3-1. Control Panel

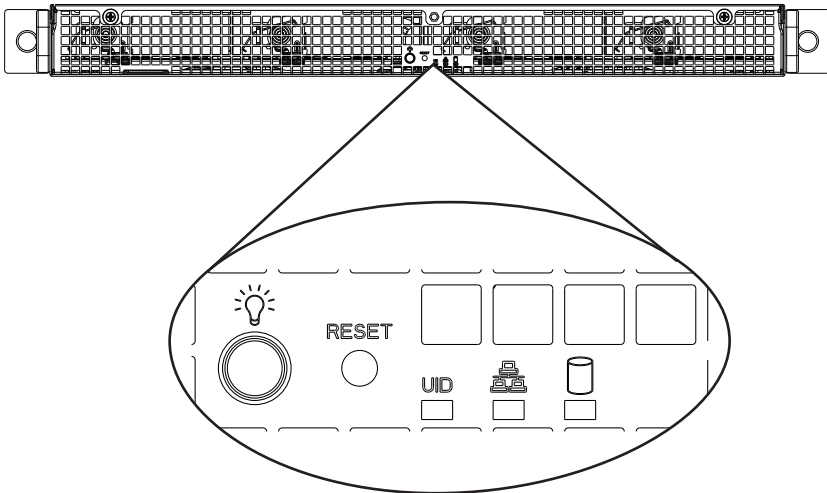

## 3-2 Control Panel Buttons

The chassis includes two push-buttons that control power to the system.



**Power:** The main power switch is used to apply or remove power from the power supply to the server. Turning off system power with this button removes the main power but maintains standby power.

RESET



**Reset:** The reset button is used to reboot the system.

## 3-3 Control Panel LEDs

There are five LEDs that provide status information about the system.



**UID LED:** The universal identifier (UID) blue LED is activated from the mainboard. It is used to locate the server in large racks and server banks.



**NIC:** Indicates network activity when flashing.

## Chapter 4

# Standardized Warning Statements for AC Systems

### 4-1 About Standardized Warning Statements

The following statements are industry standard warnings, provided to warn the user of situations which have the potential for bodily injury. Should you have questions or experience difficulty, contact Supermicro's Technical Support department for assistance. Only certified technicians should attempt to install or configure components.

Read this appendix in its entirety before installing or configuring components in the Supermicro chassis.

These warnings may also be found on our web site at [http://www.supermicro.com/about/policies/safety\\_information.cfm](http://www.supermicro.com/about/policies/safety_information.cfm).

#### Warning Definition



#### Warning!

This warning symbol means danger. You are in a situation that could cause bodily injury. Before you work on any equipment, be aware of the hazards involved with electrical circuitry and be familiar with standard practices for preventing accidents.

#### 警告の定義

この警告サインは危険を意味します。

人身事故につながる可能性がありますので、いずれの機器でも動作させる前に、電気回路に含まれる危険性に注意して、標準的な事故防止策に精通して下さい。

此警告符号代表危險。

您正處於可能受到嚴重傷害的工作環境中。在您使用設備開始工作之前，必須充分意識到觸電的危險，並熟练掌握防止事故發生的標準工作程序。請根據每項警告結尾的聲明號碼找到此設備的安全性警告說明的翻譯文本。

此警告符號代表危險。

您正處於可能身體可能會受損傷的工作環境中。在您使用任何設備之前，請注意觸電的危險，並且要熟悉預防事故發生的標準工作程序。請依照每一注意事項後的號碼找到相關的翻譯說明內容。

## Warnung

### WICHTIGE SICHERHEITSHINWEISE

Dieses Warnsymbol bedeutet Gefahr. Sie befinden sich in einer Situation, die zu Verletzungen führen kann. Machen Sie sich vor der Arbeit mit Geräten mit den Gefahren elektrischer Schaltungen und den üblichen Verfahren zur Vorbeugung vor Unfällen vertraut. Suchen Sie mit der am Ende jeder Warnung angegebenen Anweisungsnummer nach der jeweiligen Übersetzung in den übersetzten Sicherheitshinweisen, die zusammen mit diesem Gerät ausgeliefert wurden.

BEWAHREN SIE DIESE HINWEISE GUT AUF.

### INSTRUCCIONES IMPORTANTES DE SEGURIDAD

Este símbolo de aviso indica peligro. Existe riesgo para su integridad física. Antes de manipular cualquier equipo, considere los riesgos de la corriente eléctrica y familiarícese con los procedimientos estándar de prevención de accidentes. Al final de cada advertencia encontrará el número que le ayudará a encontrar el texto traducido en el apartado de traducciones que acompaña a este dispositivo.

GUARDE ESTAS INSTRUCCIONES.

### IMPORTANTES INFORMATIONS DE SÉCURITÉ

Ce symbole d'avertissement indique un danger. Vous vous trouvez dans une situation pouvant entraîner des blessures ou des dommages corporels. Avant de travailler sur un équipement, soyez conscient des dangers liés aux circuits électriques et familiarisez-vous avec les procédures couramment utilisées pour éviter les accidents. Pour prendre connaissance des traductions des avertissements figurant dans les consignes de sécurité traduites qui accompagnent cet appareil, référez-vous au numéro de l'instruction situé à la fin de chaque avertissement.

CONSERVEZ CES INFORMATIONS.

## תקנון הצהרות אזהרה

הצהרות הבאות הן אזהרות על פי תקני התעשייה, על מנת להזהיר את המשתמש מפני חבלה פיזית אפשרית. במידה ויש שאלות או היתקלות בבעיה כלשהי, יש ליצור קשר עם מחלקת תמיכה טכנית של סופרמיקרו. טכנאים מוסמכים בלבד רשאים להתקין או להגדיר את הרכיבים.

יש לקרוא את הנספח במלואו לפני התקנת או הגדרת הרכיבים במארזי סופרמיקרו.

تحذير! هذا الرمز يعني خطر انك في حالة يمكن أن تتسبب في اصابة جسدية .  
قبل أن تعمل على أي معدات، كن على علم بالمخاطر الناجمة عن الدوائر  
الكهربائية  
وكن على دراية بالممارسات الوقائية لمنع وقوع أي حوادث  
استخدم رقم البيان المنصوص في نهاية كل تحذير للعثور ترجمتها

안전을 위한 주의사항

경고!

이 경고 기호는 위험이 있음을 알려 줍니다. 작업자의 신체에 부상을 야기 할 수 있는 상태에 있게 됩니다. 모든 장비에 대한 작업을 수행하기 전에 전기회로와 관련된 위험요소들을 확인하시고 사전에 사고를 방지할 수 있도록 표준 작업절차를 준수해 주시기 바랍니다.

해당 번역문을 찾기 위해 각 경고의 마지막 부분에 제공된 경고문 번호를 참조하십시오

#### BELANGRIJKE VEILIGHEIDSINSTRUCTIES

Dit waarschuwings symbool betekent gevaar. U verkeert in een situatie die lichamelijk letsel kan veroorzaken. Voordat u aan enige apparatuur gaat werken, dient u zich bewust te zijn van de bij een elektrische installatie betrokken risico's en dient u op de hoogte te zijn van de standaard procedures om ongelukken te voorkomen. Gebruik de nummers aan het eind van elke waarschuwing om deze te herleiden naar de desbetreffende locatie.

#### BEWAAR DEZE INSTRUCTIES

## Installation Instructions



### Warning!

Read the installation instructions before connecting the system to the power source.

設置手順書

システムを電源に接続する前に、設置手順書をお読み下さい。

警告

将此系统连接电源前，请先阅读安装说明。

警告

將系統與電源連接前，請先閱讀安裝說明。

Warnung

Vor dem Anschließen des Systems an die Stromquelle die Installationsanweisungen lesen.

¡Advertencia!

Lea las instrucciones de instalación antes de conectar el sistema a la red de alimentación.

Attention

Avant de brancher le système sur la source d'alimentation, consulter les directives d'installation.

יש לקרוא את הוראות התקנה לפני חיבור המערכת למקור מתח.

اقرأ إرشادات التركيب قبل توصيل النظام إلى مصدر للطاقة

시스템을 전원에 연결하기 전에 설치 안내를 읽어주십시오.

Waarschuwing

Raadpleeg de installatie-instructies voordat u het systeem op de voedingsbron aansluit.

## Circuit Breaker



### Warning!

This product relies on the building's installation for short-circuit (overcurrent) protection. Ensure that the protective device is rated not greater than: 250 V, 20 A.

### サーキット・ブレーカー

この製品は、短絡(過電流)保護装置がある建物での設置を前提としています。  
保護装置の定格が250 V、20 Aを超えないことを確認下さい。

### 警告

此产品的短路(过载电流)保护由建筑物的供电系统提供,确保短路保护设备的额定电流不大于250V,20A。

### 警告

此產品的短路(過載電流)保護由建築物的供電系統提供,確保短路保護設備的額定電流不大於250V,20A。

### Warnung

Dieses Produkt ist darauf angewiesen, dass im Gebäude ein Kurzschluss- bzw. Überstromschutz installiert ist. Stellen Sie sicher, dass der Nennwert der Schutzvorrichtung nicht mehr als: 250 V, 20 A beträgt.

### ¡Advertencia!

Este equipo utiliza el sistema de protección contra cortocircuitos (o sobrecorrientes) del edificio. Asegúrese de que el dispositivo de protección no sea superior a: 250 V, 20 A.

### Attention

Pour ce qui est de la protection contre les courts-circuits (surtension), ce produit dépend de l'installation électrique du local. Vérifiez que le courant nominal du dispositif de protection n'est pas supérieur à :250 V, 20 A.

מוצר זה מסתמך על הגנה המותקנת במבנים למניעת קצר חשמלי. יש לוודא כי  
המכשיר המגן מפני הקצר החשמלי הוא לא יותר מ-250 V, 20 A

هذا المنتج يعتمد على معدات الحماية من الدوائر القصيرة التي تم تثبيتها في  
المبنى  
تأكد من أن تقييم الجهاز الوقائي ليس أكثر من: 20A, 250V

경고!

이 제품은 전원의 단락(과전류)방지에 대해서 전적으로 건물의 관련 설비에 의존합니다. 보호장치의 정격이 반드시 250V(볼트), 20A(암페어)를 초과하지 않도록 해야 합니다.

Waarschuwing

Dit product is afhankelijk van de kortsluitbeveiliging (overspanning) van uw elektrische installatie. Controleer of het beveiligde apparaat niet groter gedimensioneerd is dan 220V, 20A.

### Power Disconnection Warning



#### Warning!

The system must be disconnected from all sources of power and the power cord removed from the power supply module(s) before accessing the chassis interior to install or remove system components.

#### 電源切斷の警告

システムコンポーネントの取り付けまたは取り外しのために、シャーシ内部にアクセスするには、

システムの電源はすべてのソースから切斷され、電源コードは電源モジュールから取り外す必要があります。

警告

在你打开机箱并安装或移除内部器件前,必须将系统完全断电,并移除电源线。

警告

在您打開機殼安裝或移除內部元件前,必須將系統完全斷電,並移除電源線。

Warnung

Das System muss von allen Quellen der Energie und vom Netzanschlusskabel getrennt sein, das von den Spg.Versorgungsteilmodulen entfernt wird, bevor es auf den Chassisinnenraum zurückgreift, um Systemsbestandteile anzubringen oder zu entfernen.

¡Advertencia!

El sistema debe ser disconnected de todas las fuentes de energía y del cable eléctrico quitado de los módulos de fuente de alimentación antes de tener acceso el interior del chasis para instalar o para quitar componentes de sistema.

Attention

Le système doit être débranché de toutes les sources de puissance ainsi que de son cordon d'alimentation secteur avant d'accéder à l'intérieur du chasis pour installer ou enlever des composants de système.

## אזהרה מפני ניתוק חשמלי

### אזהרה!

יש לנתק את המערכת מכל מקורות החשמל ויש להסיר את כבל החשמלי מהספק לפני גישה לחלק הפנימי של המארז לצורך התקנת או הסרת רכיבים.

يجب فصل النظام من جميع مصادر الطاقة وإزالة سلك الكهرباء من وحدة امداد الطاقة قبل الوصول إلى المناطق الداخلية للهيكل لتثبيت أو إزالة مكونات الجهاز

경고!

시스템에 부품들을 장착하거나 제거하기 위해서는 새시 내부에 접근하기 전에 반드시 전원 공급장치로부터 연결되어있는 모든 전원과 전기코드를 분리해주어야 합니다.

Waarschuwing

Voordat u toegang neemt tot het binnenwerk van de behuizing voor het installeren of verwijderen van systeem onderdelen, dient u alle spanningsbronnen en alle stroomkabels aangesloten op de voeding(en) van de behuizing te verwijderen

## Equipment Installation



### Warning!

Only trained and qualified personnel should be allowed to install, replace, or service this equipment.

### 機器の設置

トレーニングを受け認定された人だけがこの装置の設置、交換、またはサービスを許可されています。

### 警告

只有经过培训且具有资格的人员才能进行此设备的安装、更换和维修。

### 警告

只有經過受訓且具資格人員才可安裝、更換與維修此設備。

### Warnung

Das Installieren, Ersetzen oder Bedienen dieser Ausrüstung sollte nur geschultem, qualifiziertem Personal gestattet werden.

### ¡Advertencia!

Solamente el personal calificado debe instalar, reemplazar o utilizar este equipo.

### Attention

Il est vivement recommandé de confier l'installation, le remplacement et la maintenance de ces équipements à des personnels qualifiés et expérimentés.

### אזהרה!

צוות מוסמך בלבד רשאי להתקין, להחליף את הציוד או לתת שירות עבור הציוד.

يجب أن يسمح فقط للموظفين المؤهلين والمدربين لتثبيت واستبدال أو خدمة هذا الجهاز

### 경고!

훈련을 받고 공인된 기술자만이 이 장비의 설치, 교체 또는 서비스를 수행할 수 있습니다.

## Waarschuwing

Deze apparatuur mag alleen worden geïnstalleerd, vervangen of hersteld door geschoold en gekwalificeerd personeel.

## Restricted Area



### Warning!

This unit is intended for installation in restricted access areas. A restricted access area can be accessed only through the use of a special tool, lock and key, or other means of security. (This warning does not apply to workstations).

### アクセス制限区域

このユニットは、アクセス制限区域に設置されることを想定しています。

アクセス制限区域は、特別なツール、鍵と錠前、その他のセキュリティの手段を用いてのみ出入りが可能です。

### 警告

此部件应安装在限制进出的场所，限制进出的场所指只能通过使用特殊工具、锁和钥匙或其它安全手段进出的场所。

### 警告

此裝置僅限安裝於進出管制區域，進出管制區域係指僅能以特殊工具、鎖頭及鑰匙或其他安全方式才能進入的區域。

### Warnung

Diese Einheit ist zur Installation in Bereichen mit beschränktem Zutritt vorgesehen. Der Zutritt zu derartigen Bereichen ist nur mit einem Spezialwerkzeug, Schloss und Schlüssel oder einer sonstigen Sicherheitsvorkehrung möglich.

### ¡Advertencia!

Esta unidad ha sido diseñada para instalación en áreas de acceso restringido. Sólo puede obtenerse acceso a una de estas áreas mediante la utilización de una herramienta especial, cerradura con llave u otro medio de seguridad.

### Attention

Cet appareil doit être installée dans des zones d'accès réservés. L'accès à une zone d'accès réservé n'est possible qu'en utilisant un outil spécial, un mécanisme de verrouillage et une clé, ou tout autre moyen de sécurité.

---

## אזור עם גישה מוגבלת

### אזהרה!

יש להתקין את היחידה באזורים שיש בהם הגבלת גישה. הגישה ניתנת בעזרת כלי אבטחה בלבד (מפתח, מנעול וכד').

تم تخصيص هذه الوحدة لتركيبها في مناطق محظورة .  
يمكن الوصول إلى منطقة محظورة فقط من خلال استخدام أداة خاصة،  
قفل ومفتاح أو أي وسيلة أخرى للأمان

경고!

이 장치는 접근이 제한된 구역에 설치하도록 되어있습니다. 특수도구, 잠금 장치 및 키, 또는 기타 보안 수단을 통해서만 접근 제한 구역에 들어갈 수 있습니다.

### Waarschuwing

Dit apparaat is bedoeld voor installatie in gebieden met een beperkte toegang. Toegang tot dergelijke gebieden kunnen alleen verkregen worden door gebruik te maken van speciaal gereedschap, slot en sleutel of andere veiligheidsmaatregelen.

## Battery Handling



### Warning!

There is the danger of explosion if the battery is replaced incorrectly. Replace the battery only with the same or equivalent type recommended by the manufacturer. Dispose of used batteries according to the manufacturer's instructions

### 電池の取り扱い

電池交換が正しく行われなかった場合、破裂の危険性があります。交換する電池はメーカーが推奨する型、または同等のものを使用下さい。使用済電池は製造元の指示に従って処分して下さい。

### 警告

电池更换不当会有爆炸危险。请只使用同类电池或制造商推荐的功能相当的电池更换原有电池。请按制造商的说明处理废旧电池。

### 警告

電池更換不當會有爆炸危險。請使用製造商建議之相同或功能相當的電池更換原有電池。請按照製造商的說明指示處理廢棄舊電池。

Warnung

Bei Einsetzen einer falschen Batterie besteht Explosionsgefahr. Ersetzen Sie die Batterie nur durch den gleichen oder vom Hersteller empfohlenen Batterietyp. Entsorgen Sie die benutzten Batterien nach den Anweisungen des Herstellers.

Attention

Danger d'explosion si la pile n'est pas remplacée correctement. Ne la remplacer que par une pile de type semblable ou équivalent, recommandée par le fabricant. Jeter les piles usagées conformément aux instructions du fabricant.

¡Advertencia!

Existe peligro de explosión si la batería se reemplaza de manera incorrecta. Reemplazar la batería exclusivamente con el mismo tipo o el equivalente recomendado por el fabricante. Desechar las baterías gastadas según las instrucciones del fabricante.

**אזהרה!**

קיימת סכנת פיצוץ של הסוללה במידה והוחלפה בדרך לא תקינה. יש להחליף את הסוללה בסוג התואם מחברת יצרן מומלצת.

סילוק הסוללות המשומשות יש לבצע לפי הוראות היצרן.

هناك خطر من انفجار في حالة استبدال البطارية بطريقة غير صحيحة فعليك استبدال البطارية فقط بنفس النوع أو ما يعادلها كما أوصت به الشركة المصنعة تخلص من البطاريات المستعملة وفقا لتعليمات الشركة الصانعة

경고!

배터리가 올바르게 교체되지 않으면 폭발의 위험이 있습니다. 기존 배터리와 동일하거나 제조사에서 권장하는 동등한 종류의 배터리로만 교체해야 합니다. 제조사의 안내에 따라 사용된 배터리를 처리하여 주십시오.

Waarschuwing

Er is ontploffingsgevaar indien de batterij verkeerd vervangen wordt. Vervang de batterij slechts met hetzelfde of een equivalent type die door de fabrikant aanbevolen wordt. Gebruikte batterijen dienen overeenkomstig fabrieksvoorschriften afgevoerd te worden.

## Redundant Power Supplies



### Warning!

This unit might have more than one power supply connection. All connections must be removed to de-energize the unit.

### 冗長電源装置

このユニットは複数の電源装置が接続されている場合があります。  
ユニットの電源を切るためには、すべての接続を取り外さなければなりません。

### 警告

此部件连接的电源可能不止一个，必须将所有电源断开才能停止给该部件供电。

### 警告

此装置连接的电源可能不只一个，必须切断所有电源才能停止对该装置的供电。

### Warnung

Dieses Gerät kann mehr als eine Stromzufuhr haben. Um sicherzustellen, dass der Einheit kein Strom zugeführt wird, müssen alle Verbindungen entfernt werden.

### ¡Advertencia!

Puede que esta unidad tenga más de una conexión para fuentes de alimentación. Para cortar por completo el suministro de energía, deben desconectarse todas las conexiones.

### Attention

Cette unité peut avoir plus d'une connexion d'alimentation. Pour supprimer toute tension et tout courant électrique de l'unité, toutes les connexions d'alimentation doivent être débranchées.

**אם קיים יותר מספק אחד**

**אזהרה!**

ליחידה יש יותר מחיבור אחד של ספק. יש להסיר את כל החיבורים על מנת לרוקן את היחידה.

قد يكون لهذا الجهاز عدة اتصالات بوحدات امداد الطاقة.  
يجب إزالة كافة الاتصالات لعزل الوحدة عن الكهرباء

경고!

이 장치에는 한 개 이상의 전원 공급 단자가 연결되어 있을 수 있습니다. 이 장치에 전원을 차단하기 위해서는 모든 연결 단자를 제거해야만 합니다.

Waarschuwing

Deze eenheid kan meer dan één stroomtoevoeraansluiting bevatten. Alle aansluitingen dienen verwijderd te worden om het apparaat stroomloos te maken.

### Backplane Voltage



**Warning!**

Hazardous voltage or energy is present on the backplane when the system is operating. Use caution when servicing.

バックプレーンの電圧

システムの稼働中は危険な電圧または電力が、バックプレーン上にかかっています。  
修理するには注意ください。

警告

当系统正在进行时，背板上有很危险的电压或能量，进行维修时务必小心。

警告

當系統正在進行時，背板上有很危險的電壓或能量，進行維修時務必小心。

Warnung

Wenn das System in Betrieb ist, treten auf der Rückwandplatine gefährliche Spannungen oder Energien auf. Vorsicht bei der Wartung.

¡Advertencia!

Cuando el sistema está en funcionamiento, el voltaje del plano trasero es peligroso. Tenga cuidado cuando lo revise.

#### Attention

Lorsque le système est en fonctionnement, des tensions électriques circulent sur le fond de panier. Prendre des précautions lors de la maintenance.

#### מתח בפנל האחורי

אזהרה!  
קיימת סכנת מתח בפנל האחורי בזמן תפעול המערכת. יש להיזהר במהלך העבודה.

هناك خطر من التيار الكهربائي أو الطاقة الموجودة على اللوحة عندما يكون النظام يعمل كن حذرا عند خدمة هذا الجهاز

#### 경고!

시스템이 동작 중일 때 후면판 (Backplane)에는 위험한 전압이나 에너지가 발생합니다. 서비스 작업 시 주의하십시오.

#### Waarschuwing

Een gevaarlijke spanning of energie is aanwezig op de backplane wanneer het systeem in gebruik is. Voorzichtigheid is geboden tijdens het onderhoud.

### Comply with Local and National Electrical Codes



#### Warning!

Installation of the equipment must comply with local and national electrical codes.

#### 地方および国の電気規格に準拠

機器の取り付けはその地方および国の電気規格に準拠する必要があります。

#### 警告

设备安装必须符合本地与本国电气法规。

#### 警告

設備安裝必須符合本地與本國電氣法規。

#### Warnung

Die Installation der Geräte muss den Sicherheitsstandards entsprechen.

¡Advertencia!

La instalacion del equipo debe cumplir con las normas de electricidad locales y nacionales. Attention

L'équipement doit être installé conformément aux normes électriques nationales et locales.

## תיאום חוקי החשמל הארצי

אזהרה!

התקנת הציוד חייבת להיות תואמת לחוקי החשמל המקומיים והארציים.

تركيب المعدات الكهربائية يجب أن يمتثل للقوانين المحلية والوطنية المتعلقة بالكهرباء

경고!

현 지역 및 국가의 전기 규정에 따라 장비를 설치해야 합니다.

Waarschuwing

Bij installatie van de apparatuur moet worden voldaan aan de lokale en nationale elektriciteitsvoorschriften.

## Product Disposal



**Warning!**

Ultimate disposal of this product should be handled according to all national laws and regulations.

製品の廃棄

この製品を廃棄処分する場合、国の関係する全ての法律・条例に従い処理する必要があります。

警告

本产品的废弃处理应根据所有国家的法律和规章进行。

警告

本產品的廢棄處理應根據所有國家的法律和規章進行。

### Warnung

Die Entsorgung dieses Produkts sollte gemäß allen Bestimmungen und Gesetzen des Landes erfolgen.

### ¡Advertencia!

Al deshacerse por completo de este producto debe seguir todas las leyes y reglamentos nacionales.

### Attention

La mise au rebut ou le recyclage de ce produit sont généralement soumis à des lois et/ou directives de respect de l'environnement. Renseignez-vous auprès de l'organisme compétent.

### סילוק המוצר

אזהרה!

סילוק סופי של מוצר זה חייב להיות בהתאם להנחיות וחוקי המדינה.

عند التخلص النهائي من هذا المنتج ينبغي التعامل معه وفقا لجميع القوانين واللوائح الوطنية

경고!

이 제품은 해당 국가의 관련 법규 및 규정에 따라 폐기되어야 합니다.

### Waarschuwing

De uiteindelijke verwijdering van dit product dient te geschieden in overeenstemming met alle nationale wetten en reglementen.

## Hot Swap Fan Warning



### Warning!

The fans might still be turning when you remove the fan assembly from the chassis. Keep fingers, screwdrivers, and other objects away from the openings in the fan assembly's housing.

### ファン・ホットスワップの警告

シャーシから冷却ファン装置を取り外した際、ファンがまだ回転している可能性があります。ファンの開口部に、指、ドライバー、およびその他のものを近づけないで下さい。

警告

当您从机架移除风扇装置，风扇可能仍在转动。小心不要将手指、螺丝起子和其他物品太靠近风扇

警告

當您從機架移除風扇裝置，風扇可能仍在轉動。小心不要將手指、螺絲起子和其他物品太靠近風扇。

Warnung

Die Lüfter drehen sich u. U. noch, wenn die Lüfterbaugruppe aus dem Chassis genommen wird. Halten Sie Finger, Schraubendreher und andere Gegenstände von den Öffnungen des Lüftergehäuses entfernt.

¡Advertencia!

Los ventiladores podran dar vuelta cuando usted quite el montaje del ventilador del chasis. Mantenga los dedos, los destornilladores y todos los objetos lejos de las aberturas del ventilador

Attention

Il est possible que les ventilateurs soient toujours en rotation lorsque vous retirerez le bloc ventilateur du châssis. Prenez garde à ce que doigts, tournevis et autres objets soient éloignés du logement du bloc ventilateur.

אזהרה!

כאשר מסירים את חלקי המאוורר מהמארז, יתכן והמאווררים עדיין עובדים. יש להרחיק למרחק בטוח את האצבעות וכלי עבודה שונים מהפתחים בתוך המאוורר

من الممكن أن المراوح لا تزال تدور عند إزالة كتلة المروحة من الهيكل يجب إبقاء الأصابع ومفكات البراغي وغيرها من الأشياء بعيدا عن الفتحات في كتلة المروحة.

경고!

새시로부터 팬 조립품을 제거할 때 팬은 여전히 회전하고 있을 수 있습니다. 팬 조립품 외관의 열려있는 부분들로부터 손가락 및 스크류드라이버, 다른 물체들이 가까이 하지 않도록 배치해 주십시오.

## Waarschuwing

Het is mogelijk dat de ventilator nog draait tijdens het verwijderen van het ventilatorsamenstel uit het chassis. Houd uw vingers, schroevendraaiers en eventuele andere voorwerpen uit de buurt van de openingen in de ventilatorbehuizing.

## Power Cable and AC Adapter



### Warning!

When installing the product, use the provided or designated connection cables, power cables and AC adaptors. Using any other cables and adaptors could cause a malfunction or a fire. Electrical Appliance and Material Safety Law prohibits the use of UL or CSA -certified cables (that have UL/CSA shown on the code) for any other electrical devices than products designated by Supermicro only.

### 電源コードとACアダプター

製品を設置する場合、提供または指定された接続ケーブル、電源コードとACアダプターを使用下さい。他のケーブルやアダプタを使用すると故障や火災の原因になることがあります。電気用品安全法は、ULまたはCSA認定のケーブル(UL/CSEマークがコードに表記)を Supermicroが指定する製品以外に使用することを禁止しています。

### 警告

安裝此產品時，請使用本身提供的或指定的連接線，電源線和電源適配器。使用其它線材或適配器可能會引起故障或火災。除了 Supermicro 所指定的產品，電氣用品和材料安全法律規定禁止使用未經 UL 或 CSA 認證的線材。（線材上會顯示 UL/CSA 符號）。

### 警告

安裝此產品時，請使用本身提供的或指定的連接線，電源線和電源適配器。使用其它線材或適配器可能會引起故障或火災。除了 Supermicro 所指定的產品，電氣用品和材料安全法律規定禁止使用未經 UL 或 CSA 認證的線材。（線材上會顯示 UL/CSA 符號）。

### Warnung

Bei der Installation des Produkts, die zur Verfügung gestellten oder benannt Anschlusskabel, Stromkabel und Netzteile. Verwendung anderer Kabel und Adapter kann zu einer Fehlfunktion oder ein Brand entstehen. Elektrische Geräte und Material Safety Law verbietet die Verwendung von UL-oder CSA-zertifizierte Kabel, UL oder CSA auf der Code für alle anderen elektrischen Geräte als Produkte von Supermicro nur bezeichnet gezeigt haben.

**¡Advertencia!**

Al instalar el producto, utilice los cables de conexión previstos o designados, los cables y adaptadores de CA. La utilización de otros cables y adaptadores podría ocasionar un mal funcionamiento o un incendio. Aparatos Eléctricos y la Ley de Seguridad del Material prohíbe el uso de UL o CSA cables certificados que tienen UL o CSA se muestra en el código de otros dispositivos eléctricos que los productos designados por Supermicro solamente.

**Attention**

Lors de l'installation du produit, utilisez les bables de connection fournis ou désigné. L'utilisation d'autres cables et adaptateurs peut provoquer un dysfonctionnement ou un incendie. Appareils électroménagers et de loi sur la sécurité Matériel interdit l'utilisation de UL ou CSA câbles certifiés qui ont UL ou CSA indiqué sur le code pour tous les autres appareils électriques que les produits désignés par Supermicro seulement.

**חשמליים ומתאמי AC****אזהרה!**

כאשר מתקינים את המוצר, יש להשתמש בכבלים, ספקים ומתאמים AC אשר נועדו וסופקו לשם כך. שימוש בכל כבל או מתאם אחר יכול לגרום לתקלה או קצר חשמלי. על פי חוקי שימוש במכשירי חשמל וחוקי בטיחות, קיים איסור להשתמש בכבלים המוסמכים ב- UL או ב- CSA (כשאר מופיע עליהם קוד של UL/CSA) עבור כל מוצר חשמלי אחר שלא צויין על ידי סופרמיקרו בלבד.

عند تركيب الجهاز يجب استخدام كابلات التوصيل، والكابلات الكهربائية  
ومحولات التيار المتردد

التي . أن استخدام أي كابلات ومحولات أخرى يتسبب في حدوث عطل أو حريق.  
تم توفيرها لك مع المنتج

الأجهزة الكهربائية ومواد قانون السلامة يحظر استخدام الكابلات CSA أو UL  
معتمدة من قبل

لأي أجهزة كهربائية أخرى غير المنتجات المعينة من قبل Supermicro  
(التي تحمل علامة UL/CSA)

**경고!**

제품을 설치할 때에는 제공되거나 지정된 연결케이블과 전원케이블, AC 어댑터를 사용해야 합니다. 그 밖의 다른 케이블들이나 어댑터들은 고장 또는 화재의 원인이 될 수 있습니다. 전기용품안전법 (Electrical Appliance and Material Safety Law)은 슈퍼마이크로에서 지정한 제품들 외에는 그 밖의 다른 전기 장치들을 위한 UL 또는 CSA에서 인증한 케이블(전선 위에 UL/CSA가 표시)들의 사용을 금지합니다.

### Waarschuwing

Bij het installeren van het product, gebruik de meegeleverde of aangewezen kabels, stroomkabels en adapters. Het gebruik van andere kabels en adapters kan leiden tot een storing of een brand. Elektrisch apparaat en veiligheidsinformatiebladen wet verbiedt het gebruik van UL of CSA gecertificeerde kabels die UL of CSA die op de code voor andere elektrische apparaten dan de producten die door Supermicro alleen.

## Chapter 5

### Microserver System Setup

This chapter covers the steps required to setup the K1048-RT system. Remember to completely close the chassis when you have finished working with the mainboard to better cool and protect the system.

#### 5-1 Rear I/O Ports

See Figure 5-1 below for the locations of the various I/O ports.

Figure 5-1. Rear I/O Ports

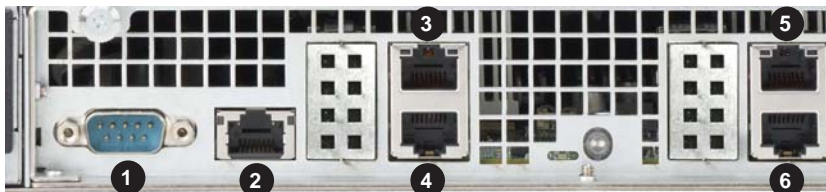

Back Panel I/O Port Locations and Definitions	
1	Serial Management Port (not used/inactive)
2	IPMI LAN Port
3	Gigabit 10G LAN Port
4	Gigabit 10G LAN Port
5	Gigabit 10G LAN Port
6	Gigabit 10G LAN Port

## 5-2 Mainboard Details

Figure 5-2. K1048-RT Layout and Drive Enumeration

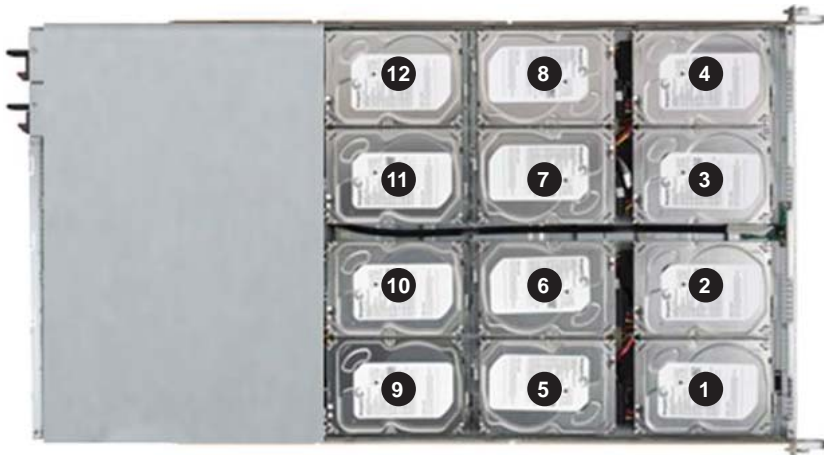

### Notes:

1. Use only the correct type of onboard CMOS battery as specified by the manufacturer. Do not install the onboard battery upside down to avoid possible explosion.
2. When the Onboard Power LED on the front control panel is on, the system power is on. Unplug the power cable before installing or removing any components.
3. Changing BMC IP address and log-in information is required to avoid address conflicts if setting up more than one unit on your network.
4. Upon system bootup, the default IP address is **192.168.1.99**, change this to an available IP address on your network. The default username is ADMIN and password is ADMIN.
5. For BMC best practices, please refer to: [http://www.supermicro.com/products/nfo/files/IPMI/Best\\_Practices\\_BMC\\_Security.pdf](http://www.supermicro.com/products/nfo/files/IPMI/Best_Practices_BMC_Security.pdf).

Connector	Description
JLAN1-4	10-Gigabit Ethernet LAN Ports
IPMI Port	IPMI Ethernet Port

## 5-3 Connector Definitions

### LAN1~4 (Ethernet Ports)

Four 10-Gigabit Ethernet ports (designated LAN1 through LAN4) are located in the rear of the K1048-RT server. Additionally, there is a dedicated LAN for IPMI in the rear of the server. These Ethernet ports accept RJ45 type cables.

**Note:** Please refer to the LED Indicator Section for LAN LED information.

### Fan Headers

This mainboard has six system fan headers on the mainboard. These 4-pin fans headers are backward compatible with the traditional 3-pin fans. The fan speeds are controlled by firmware thermal management via IPMI 2.0. See the table on the right for pin definitions.

Fan Header Pin Definitions	
Pin#	Definition
1	Ground
2	+12V
3	Tachometer
4	Firmware Thermal Control

## 5-4 Onboard Indicators

### LAN LEDs

The Ethernet LAN port is located on the IO Backplane on the mainboard. Each LAN port has two LEDs. The Yellow LED indicates activity. The Link LED on the left side of the LAN port may be green, amber or off to indicate the speed of the connection. See the tables on the right for more information.

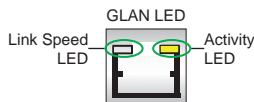

LAN Link Indicator LED Settings	
LED Color	Definition
Off	No Connection, 10 or 100 Mbps
Amber	1 Gbps
Green	10 Gbps (X9DRT-PT only)

LAN LED Indicator Settings		
LAN Speeds	1 Gbps	10 Gbps
10/100	Green	Off
1G	Amber	Amber
10G (X9DRT-PT only)	N/A	Green

### IPMI Dedicated LAN LEDs

In addition to the LAN Port 1, an IPMI Dedicated LAN is also located on the I/O Backplane. The amber LED on the right indicates connection and activity; while the green LED on the left indicates the speed of the connection. See the tables at right for more information.

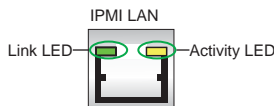

IPMI LAN Link/Speed LED (Left) & Activity LED (Right)		
Color	Status	Definition
Off	Off	No Connection
Green: Solid	Link/Speed (Left)	100 Mb/s
Amber Blinking	Activity (Right)	Active

## 5-5 System Battery

**Caution:** There is a danger of explosion if the onboard battery is installed upside down, which will reverse its polarities (see Figure 5-9). This battery must be replaced only with the same or an equivalent type recommended by the manufacturer (CR2032). Dispose of used batteries according to the manufacturer's instructions.

**Figure 5-9. Installing the Onboard Battery**

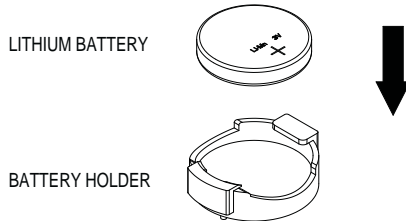

Please handle used batteries carefully. Do not damage the battery in any way; a damaged battery may release hazardous materials into the environment. Do not discard a used battery in the garbage or a public landfill. Please comply with the regulations set up by your local hazardous waste management agency to dispose of your used battery properly.

## Notes

## Chapter 6

### Advanced Chassis Setup

This chapter covers the steps required to install components and perform maintenance on the SC801LTS-R406KP chassis. For component installation, follow the steps in the order given to eliminate the most common problems encountered. If some steps are unnecessary, skip ahead to the step that follows.

**Tools Required:** The only tool you will need to install components and perform maintenance is a Philips screwdriver.

#### 6-1 Static-Sensitive Devices

Electrostatic discharge (ESD) can damage electronic components. To prevent damage to any printed circuit boards (PCBs), it is important to handle them very carefully. The following measures are generally sufficient to protect your equipment from ESD damage.

##### Precautions

- Use a grounded wrist strap designed to prevent static discharge.
- Touch a grounded metal object before removing any board from its antistatic bag.
- Handle a board by its edges only; do not touch its components, peripheral chips, memory modules or gold contacts.
- When handling chips or modules, avoid touching their pins.
- Put the mainboard, expansion cards and peripherals back into their antistatic bags when not in use.
- For grounding purposes, make sure your computer chassis provides excellent conductivity between the power supply, the case, the mounting fasteners and the mainboard.

Figure 6-1. Front and Rear Chassis Views

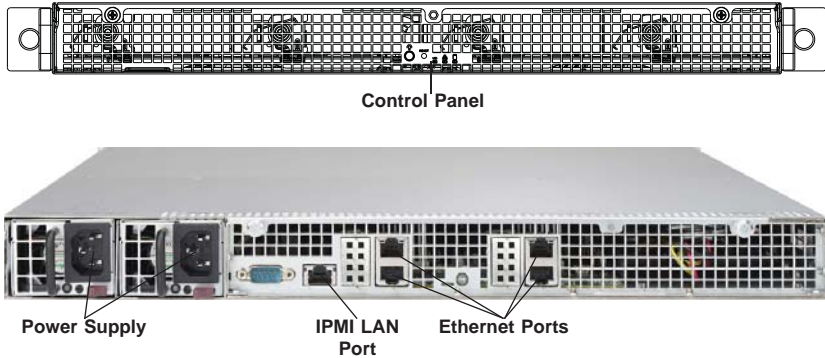

## 6-2 Removing the Power Cord

Before performing most setup or maintenance tasks, use the following procedure to ensure that power has been removed from the system.

1. Use the operating system to power down the system, following the on-screen prompts.
2. After the system has completely shut-down, carefully grasp the head of the power cord and gently pull it out of the back of the power supply. If your system has dual power supplies, remove the cords from both power supplies.
3. Disconnect the cord from the power strip or wall outlet.

## 6-3 Control Panel

The control panel is located on the front of the chassis. The LEDs inform you of system status.

See Chapter 3 for details on the LEDs and the control panel buttons.

## 6-4 Removing the Chassis Cover

The system is fully accessible by removing the two chassis covers. Each is secured by a small metal lip in the middle of the chassis and by two thumb screws on the front or rear of the chassis.

Figure 6-2. Removing the Chassis Cover

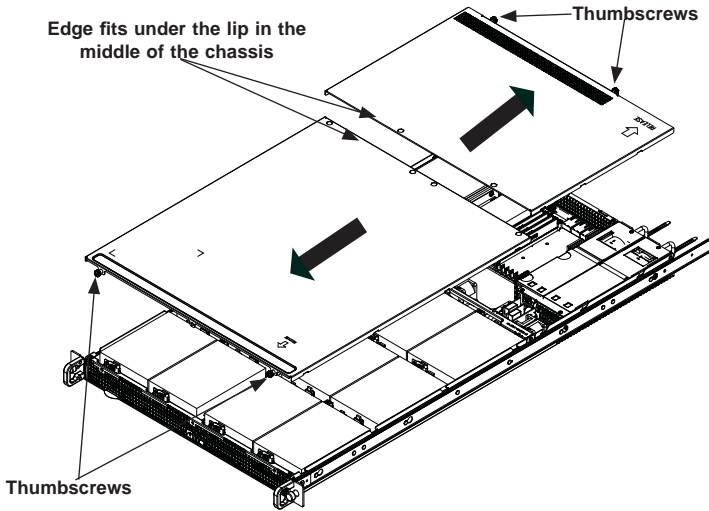

### *Removing a Chassis Cover:*

1. Loosen the two thumb screws on the front or rear of the chassis.
2. Slide the cover away from the middle and off.

**Caution:** Except for short periods of time, do not operate the system without the cover in place. The chassis cover must be in place to allow proper airflow and prevent overheating.

## 6-5 Installing and Replacing Hard Drives

The chassis can contain twelve 3.5" fixed hard disk drives. Each HDD position in the chassis is labeled with a number that corresponds to the persistent drive bay enumeration.

The drives rest on metal brackets that runs the full width of the chassis. They attach to the system by means of cables individually connecting power and Ethernet using standard SAS HDD connectors. Ethernet drives re-purpose the standard SAS HDD connector. Please see manufacturer specifications.

Refer to the **Quick Start Sticker** that is mounted in the top cover of the K1048-RT for information on quick starting the system for use and replacing HDDs.

Figure 6-3. Quick Start Sticker

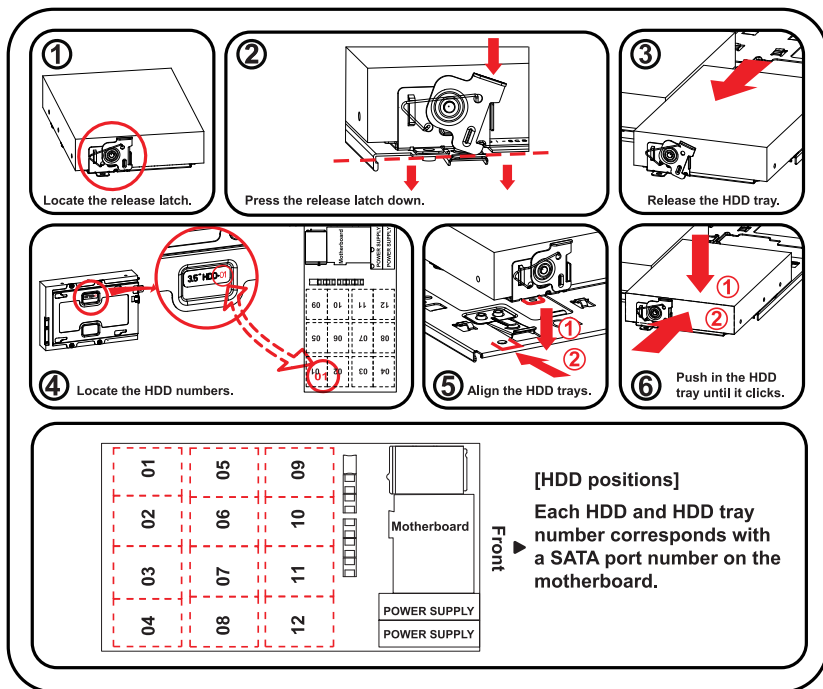

### Replacing a Hard Drive

This procedure may be performed while the system is operating (hot-replacement) extra caution should be taken when replacing drives near the high speed fans (drive bays 9, 10, 11 and 12).

1. Remove front/HDD cover from the chassis (Figure 6-2).
2. Locate and press the latch down on the HDD you wish to remove from the chassis (Figure 6-3 and Figure 6-4).
3. Disconnect the drive connection from the HDD. Note the number on the floor of the chassis.
4. Remove the metal tray from the dead drive and install it on the replacement drive.
5. Connect the drive cable and gently push it down onto the mounting bracket until it clicks into position.

Figure 6-4. Replacing HDDs

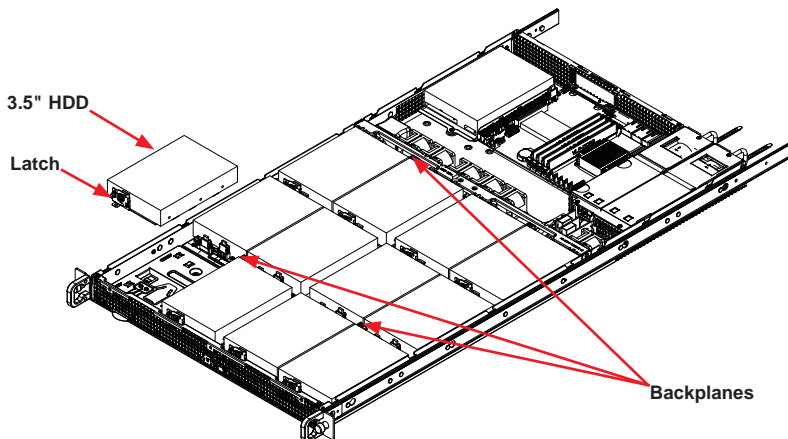

**Figure 6-5. Chassis and HDD Mounting Brackets**

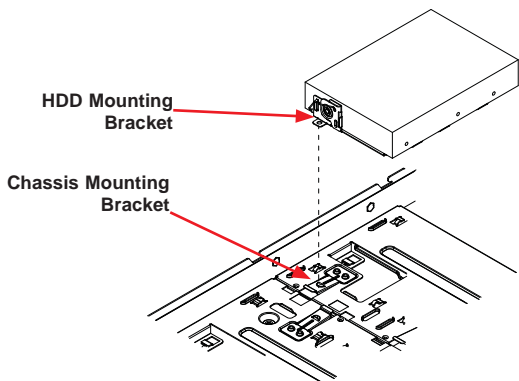

## 6-6 System Fans

Six fans (fixed mounted) provide cooling for the chassis. Replacement of fans should be performed by trained field technicians while the system is powered off.

**Figure 6-6. System Fans (lifted out of chassis)**

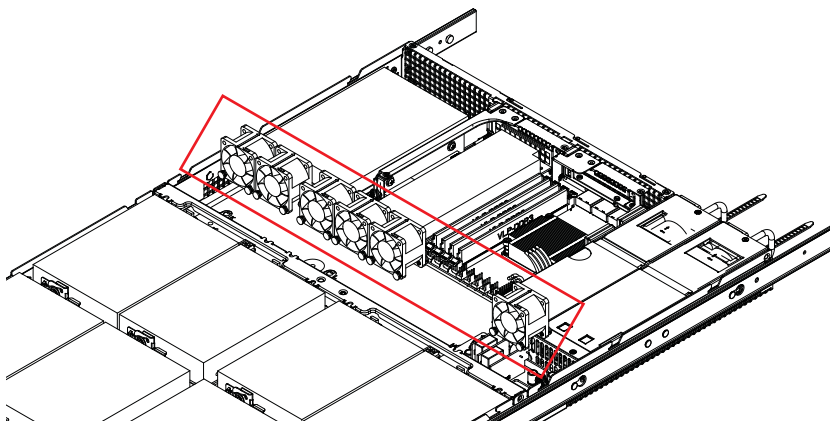

### ***Replacing a System Fan***

1. If necessary, open the top rear cover of the chassis while the system is running to locate the position of the failed fan. Do not run the server for an extended time with the cover off.
2. Power down the system.
3. Remove the failed fan's power cable from the mainboard.
4. Remove the four pins securing the fan to the fan housing.
5. Lift the failed fan from the fan housing and out of the chassis.
6. Place the new fan into the vacant space in the fan housing, while making sure the arrows on the top of the fan (indicating air direction) point in the same direction as the arrows on the other fans in the same fan housing.
7. Reconnect the fan wires to the same chassis fan headers as the previous fan.
8. Power up the system and check that the fan is working properly before replacing the chassis cover.

## 6-7 Power Supply

The system has two 400 Watt, redundant, hot-swap power supply modules. They automatically sense the input voltage between 100v to 240v, and operate at that voltage. An amber light on the power supply is illuminated when the power is switched off. A green light indicates that the power supply is operating.

Replacement units can be ordered directly from Supermicro.

**Figure 6-7. Power Supply Modules**

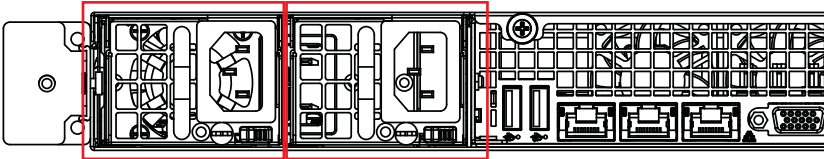

### ***Replacing the Power Supply***

1. Remove the AC power cord from the back of the power supply module.
2. Push the release tab on the rear of the power supply.
3. Pull the power supply out of the power supply bay using the handle.
4. Push the new power supply module into the power bay until it clicks.
5. Plug the AC power cord back into the module and power up the server.

# Appendix A

## System Specifications

**Note:** Unless noted specifications apply to a complete system (all serverboards).

### Drive Bays

The K1048-RT contains twelve (12) hot-swap drive bays that support standard 3.5" Ethernet drives.

**Note:** The system HDD's ARE hot-plug.

### Chassis

SC801LTS-R406KP (1U rackmount)

Dimensions: (HxWxD) 1.7" x 17.2" x 32" (43mm x 437mm x 813mm)

### Weight

Gross (Bare Bone): 38 lbs (16.5 kg)

### System Cooling

The system has six (6) 8-cm PWM system cooling fans

**Note:** The system cooling fans are NOT redundant, hot-plug.

### System Input Requirements

AC Input Voltage: 100-240 V

Rated Input Current: 6-3 Amp

Rated Input Frequency: 47 to 63 Hz

Efficiency: 90+ (Gold Level)

### Power Supply

Rated Output Power: 400 Watts (Part# PWS-406P-1R)

Rated Output Voltages: +12V (33A), +5Vsb (3A)

### Operating Environment

Operating Temperature: 0° to 35° C (50° to 95° F)

Non-operating Temperature: -40° to 70° C (-40° to 158° F)

Operating Relative Humidity: 20% to 95% (non-condensing)

Non-operating Relative Humidity: 5 to 95% (non-condensing)

**Note:** The system power supplies are redundant, hot-plug.

## **Regulatory Compliance**

Electromagnetic Emissions: FCC Class A, EN 55022 Class A, EN 61000-3-2/-3-3, CISPR 22 Class A

Electromagnetic Immunity: EN 55024/CISPR 24, (EN 61000-4-2, EN 61000-4-3, EN 61000-4-4, EN 61000-4-5, EN 61000-4-6, EN 61000-4-8, EN 61000-4-11)

Safety: CSA/EN/IEC/UL 60950-1 Compliant, UL or CSA Listed (USA and Canada), CE Marking (Europe)

California Best Management Practices Regulations for Perchlorate Materials:  
This Perchlorate warning applies only to products containing CR (Manganese Dioxide) Lithium coin cells. "Perchlorate Material-special handling may apply. See [www.dtsc.ca.gov/hazardouswaste/perchlorate](http://www.dtsc.ca.gov/hazardouswaste/perchlorate)" for further details.

## Appendix B

### Storage Monitoring IPMI Page

This chapter covers the controls and features of the K1048-RT Storage Monitoring IPMI page.

Figure A-1. Storage Monitoring IPMI Page

The screenshot displays the SUPERMICRO Storage Monitoring IPMI page. The browser address bar shows the URL: 192.168.1.99/cgi/uri\_redirect.cgi?url\_name=mainindex. The page title is "Storage Monitoring". The user is identified as "ADMIN (Administrator)".

The main content area shows a table of storage information:

Hard Drive ID	Status	Temperature
1	Present	27 °C
2	Present	28 °C
3	Present	28 °C
4	Present	28 °C
5	Present	28 °C
6	Present	28 °C
7	Present	29 °C
8	Present	28 °C
9	Present	27 °C
10	Present	28 °C
11	Present	29 °C
12	Present	29 °C

Details for Hard Drive:1 are shown on the right:

**Hard Drive:1 Present**

Identify Device:

- Worldwide Name: 5000c500670e9be4
- Eth0 MAC Address: 00:11:c6:01:1a:c4
- Eth1 MAC Address: 00:11:c6:01:1a:c5

Device Temperature: 27 °C  
Kinetic Version: 2.1.1  
Command Set Version: 1.1.0

Refresh

### Using the IPMI Screen

Follow the procedure below for using the Storage Monitoring IPMI page for the K1048-RT.

#### Using the Storage Monitoring Page

1. Click on **Storage Monitoring** to bring up the Storage Monitoring page.
2. Click on a device/HDD bay in the window to view details on the device.

Each device chosen shows details such as Temperature, Status, MAC Address, Worldwide Name and version information. Press the Refresh button to refresh the information on the screen.

## I2C Commands

Below are the Opcodes I2C commands that you can use.

I2C Commands	
Opcode	Name
0x02	Get Manufacturer
0x03	Get Product ID
0x05	Identify Device
0x06	Get Device Temperature
0x08	Get Device IP Address
0x09	Set Device Network Speed
0x0a	Get Device Network Speed
0x0c	Enable External Loopback
0x0e	Get Command Set Version
0x0f	Disable External Loopback
0x10	Reset Device
0x12	Set Device IP Address
0x13	Get Device Network MAC
0x14	Get Interface Link State
0x15	Get Firmware Version
0x16	Get Data Protocol Version

## OEM IPMI Commands to Get Ethernet Hard Drive Information

To get Ethernet hard drive information, use the following information to get OEM IPMI commands.

**Note:** Only a subset of opcode is supported within the Ethernet interface specification. Please see manufacturer specifications.

### Standards

BMC IP address by default is set to static: **192.168.1.99**

Username: **ADMIN**

Password: **ADMIN**

```
ipmitool -U ADMIN -P ADMIN -H 192.168.1.99 raw 0x30 0x70 0x86 drive_number
```

## Byte Range

Where the drive\_number ranges from 1-12 for the twelve disks within the chassis. This command will return 284 bytes of data, as listed in the table below:

Byte Range		
Byte	Type, Possible Value	Definition
0	0/1	Device present
1-20	8 byte WWN followed by '0'	WWN
21-34	N/A	Unused
35	Hex	Temperature
35-41	N/A	Unused
42-45	Hex	HDD FW version
45	N/A	Unused
46-48	Hex	Command set version
49	N/A	Unused
50-81	Hex	Extended status
82-97	Hex	Manufacturer
98-113	Hex	Product ID
114-251	Hex	IP address for both interfaces; see below for detail
252-257	Hex	Device network speed
258-261	Hex	Device operating state
262-264	Hex	Write status
265-276	Hex	Interface MAC address for both interface; see below for detail
277-278	Hex	Interface Link state
279-283	Hex	Data Protocol Version

## ***IP Address***

Below is a breakdown of the 138 byte of IP info from 114-251.

<b>IP Address Info</b>		
<b>Byte</b>	<b>Interface</b>	<b>Definition</b>
114	Interface 0	Status
115-118		Ipv4 gateway
132-135		Ipv4 address
149-164		Ipv6 gateway
166-181		Ipv6 address
183	Interface 1	Status
184-187		Ipv4 gateway
201-204		Ipv4 address
218-233		Ipv6 gateway
235-250		Ipv6 address

## MAC Address

Below is a breakdown of 12 byte of MAC info from 265-276.

MAC Address Info		
Byte	Interface	Definition
265-270	Interface 0	MAC address
271-276	Interface 1	Mac Address

An example of a raw command to collect drive mac and IPs is shown below:

**Figure A-2. Drive Collection Raw Command Example**

```
root@username-X10DRC:/home/username# ipmitool -U ADMIN -P ADMIN -H 192.168.1.99 raw 0x30 0x70 0x86 *
```

\* denotes drive location (1-12)

```
01 50 00 c5 00 7b 26 8c 63 00 00 00 00 00 00 00
00 00 00 00 00 00 00 00 00 00 00 00 00 00 00
00 00 00 20 00 00 00 00 00 00 02 06 00 00 01 02
04 00 00 00 00 00 00 00 00 00 00 00 00 00 00
00 00 00 00 00 00 00 00 00 00 00 00 00 00 00
00 00 53 65 61 67 61 74 65 00 00 00 00 00 00
00 00 53 54 34 30 30 30 4e 4b 30 30 31 2d 31 4e
58 36 15 ac 15 00 01 ff ff 00 00 00 00 00 00
00 00 00 00 ac 15 65 7c ff ff 00 00 00 00 00
00 00 00 00 00 00 00 00 00 00 00 00 00 00 00
00 00 00 00 00 00 00 00 00 00 00 00 00 00 00
00 00 00 00 00 00 15 ac 15 00 01 ff ff 00 00
00 00 00 00 00 00 00 ac 15 65 89 ff ff 00
00 00 00 00 00 00 00 00 00 00 00 00 00 00 00
00 00 00 00 00 00 00 00 00 00 00 00 00 01 00
01 00 00 00 00 00 00 00 00 00 ff ff ff ff ff ff
ff ff ff ff 01 01 03 00 05 00 00
```

IPV4 Address for HDD port "A"  
Subnet mask

IPV4 Address for HDD port "B"  
Subnet mask

MAC for HDD Port "A"  
MAC for HDD Port "B"

(continued from front)

The products sold by Supermicro are not intended for and will not be used in life support systems, medical equipment, nuclear facilities or systems, aircraft, aircraft devices, aircraft/emergency communication devices or other critical systems whose failure to perform be reasonably expected to result in significant injury or loss of life or catastrophic property damage. Accordingly, Supermicro disclaims any and all liability, and should buyer use or sell such products for use in such ultra-hazardous applications, it does so entirely at its own risk. Furthermore, buyer agrees to fully indemnify, defend and hold Supermicro harmless for and against any and all claims, demands, actions, litigation, and proceedings of any kind arising out of or related to such ultra-hazardous use or sale.