

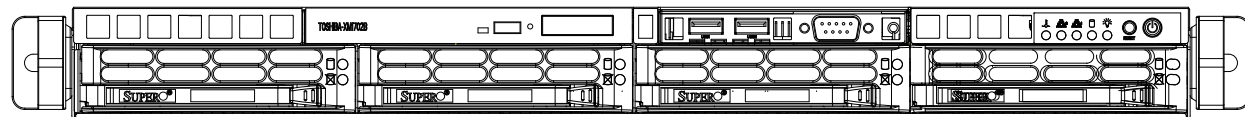

# SuperServer<sup>®</sup> 5019S-MN4



## USER'S MANUAL

Revision 1.0

The information in this User's Manual has been carefully reviewed and is believed to be accurate. The vendor assumes no responsibility for any inaccuracies that may be contained in this document, and makes no commitment to update or to keep current the information in this manual, or to notify any person or organization of the updates. **Please Note: For the most up-to-date version of this manual, please see our website at [www.supermicro.com](http://www.supermicro.com).**

Super Micro Computer, Inc. ("Supermicro") reserves the right to make changes to the product described in this manual at any time and without notice. This product, including software and documentation, is the property of Supermicro and/or its licensors, and is supplied only under a license. Any use or reproduction of this product is not allowed, except as expressly permitted by the terms of said license.

IN NO EVENT WILL Super Micro Computer, Inc. BE LIABLE FOR DIRECT, INDIRECT, SPECIAL, INCIDENTAL, SPECULATIVE OR CONSEQUENTIAL DAMAGES ARISING FROM THE USE OR INABILITY TO USE THIS PRODUCT OR DOCUMENTATION, EVEN IF ADVISED OF THE POSSIBILITY OF SUCH DAMAGES. IN PARTICULAR, SUPER MICRO COMPUTER, INC. SHALL NOT HAVE LIABILITY FOR ANY HARDWARE, SOFTWARE, OR DATA STORED OR USED WITH THE PRODUCT, INCLUDING THE COSTS OF REPAIRING, REPLACING, INTEGRATING, INSTALLING OR RECOVERING SUCH HARDWARE, SOFTWARE, OR DATA.

Any disputes arising between manufacturer and customer shall be governed by the laws of Santa Clara County in the State of California, USA. The State of California, County of Santa Clara shall be the exclusive venue for the resolution of any such disputes. Supermicro's total liability for all claims will not exceed the price paid for the hardware product.

FCC Statement: This equipment has been tested and found to comply with the limits for a Class A digital device pursuant to Part 15 of the FCC Rules. These limits are designed to provide reasonable protection against harmful interference when the equipment is operated in a commercial environment. This equipment generates, uses, and can radiate radio frequency energy and, if not installed and used in accordance with the manufacturer's instruction manual, may cause harmful interference with radio communications. Operation of this equipment in a residential area is likely to cause harmful interference, in which case you will be required to correct the interference at your own expense.

California Best Management Practices Regulations for Perchlorate Materials: This Perchlorate warning applies only to products containing CR (Manganese Dioxide) Lithium coin cells. "Perchlorate Material-special handling may apply. See [www.dtsc.ca.gov/hazardouswaste/perchlorate](http://www.dtsc.ca.gov/hazardouswaste/perchlorate)".

**WARNING:** Handling of lead solder materials used in this product may expose you to lead, a chemical known to the State of California to cause birth defects and other reproductive harm.

The products sold by Supermicro are not intended for and will not be used in life support systems, medical equipment, nuclear facilities or systems, aircraft, aircraft devices, aircraft/emergency communication devices or other critical systems whose failure to perform be reasonably expected to result in significant injury or loss of life or catastrophic property damage. Accordingly, Supermicro disclaims any and all liability, and should buyer use or sell such products for use in such ultra-hazardous applications, it does so entirely at its own risk. Furthermore, buyer agrees to fully indemnify, defend and hold Supermicro harmless for and against any and all claims, demands, actions, litigation, and proceedings of any kind arising out of or related to such ultra-hazardous use or sale.

Manual Revision 1.0

Release Date: November 25, 2015

Unless you request and receive written permission from Super Micro Computer, Inc., you may not copy any part of this document. Information in this document is subject to change without notice. Other products and companies referred to herein are trademarks or registered trademarks of their respective companies or mark holders.

Copyright © 2015 by Super Micro Computer, Inc.  
All rights reserved.

**Printed in the United States of America**

## Preface

### About this Manual

This manual is written for professional system integrators and PC technicians. It provides information for the installation and use of the SuperServer 5019S-MN4. Installation and maintenance should be performed by experienced technicians only.

Please refer to the 5019S-MN4 server specifications page on our website for updates on supported memory, processors and operating systems (<http://www.supermicro.com>).

### Notes

For your system to work properly, please follow the links below to download all necessary drivers/utilities and the user's manual for your server.

- Supermicro product manuals: <http://www.supermicro.com/support/manuals/>
- Product drivers and utilities: <ftp://ftp.supermicro.com>
- Product safety info: [http://www.supermicro.com/about/policies/safety\\_information.cfm](http://www.supermicro.com/about/policies/safety_information.cfm)

If you have any questions, please contact our support team at:  
[support@supermicro.com](mailto:support@supermicro.com)

This manual may be periodically updated without notice. Please check the Supermicro website for possible updates to the manual revision level.

### Warnings

Special attention should be given to the following symbols used in this manual.



**Warning!** Indicates important information given to prevent equipment/property damage or personal injury.



**Warning!** Indicates high voltage may be encountered when performing a procedure.

## Table of Contents

### Chapter 1 Introduction

1.1 Overview.....	8
1.2 Unpacking the System .....	8
1.3 System Specifications .....	9
1.4 Server Chassis Features.....	10
Control Panel .....	10
Front Features.....	11
Rear Features .....	12
1.5 Motherboard Layout .....	13
Quick Reference Table.....	14

### Chapter 2 Server Installation

2.1 Overview.....	17
2.2 Preparing for Setup .....	17
Choosing a Setup Location.....	17
Rack Precautions .....	17
Server Precautions.....	18
Rack Mounting Considerations .....	18
Ambient Operating Temperature.....	18
Airflow .....	18
Mechanical Loading.....	18
Circuit Overloading .....	19
Reliable Ground.....	19
2.3 Installing the Rails .....	20
Identifying the Rails.....	20
Installing the Chassis Rails.....	20
Installing the Rack Rails .....	21
2.4 Installing the Server into a Rack.....	22
Installing the Server into a Telco Rack .....	23

### Chapter 3 Maintenance and Component Installation

3.1 Removing Power .....	24
3.2 Accessing the System.....	24

3.3 Motherboard Components.....	25
Processor and Heatsink Installation.....	25
Memory Installation.....	30
Memory Support.....	30
PCI Expansion Card Installation.....	31
DIMM Module Population Sequence.....	31
Motherboard Battery.....	32
3.4 Chassis Components.....	33
Hard Drives.....	33
Hard Drive Carrier Indicators.....	34
System Cooling.....	35
Installing Fans.....	35
Air Shroud.....	36
Power Supply.....	37
Power Supply Failure.....	37
3.5 Server Connections.....	39
Control Panel.....	39
Rear I/O Ports.....	40
Data Cables.....	40
Power Cables.....	40
Peripheral Drives.....	41
SAS/SATA Drives.....	41
DVD-ROM Drive (Optional).....	41
<b>Chapter 4 Motherboard Connections</b>	
4.1 Power Connections.....	42
4.2 Headers and Connectors.....	43
Control Panel.....	48
Data Cables.....	51
Power Cables.....	51
4.3 Ports.....	52
Rear I/O Ports.....	52
4.4 Jumpers.....	55
Explanation of Jumpers.....	55

4.5 LED Indicators.....	58
<b>Chapter 5 Software</b>	
5.1 OS Installation.....	61
Installing the Windows OS for a RAID System.....	61
Installing Windows to a Non-RAID System.....	61
5.2 Driver Installation.....	62
5.3 SuperDoctor® 5.....	63
5.4 IPMI.....	64
<b>Chapter 6 BIOS</b>	
6.1 Introduction.....	65
Starting the Setup Utility.....	65
6.2 Main Setup.....	66
How To Change the Configuration Data.....	66
6.3 Advanced Setup Configurations.....	68
6.4 Event Logs.....	90
6.5 IPMI.....	91
6.6 Security.....	94
6.7 Boot Settings.....	96
6.8 Save & Exit.....	98
<b>Appendix A BIOS Error Codes</b>	
<b>Appendix B Standardized Warning Statements for AC Systems</b>	
<b>Appendix C System Specifications</b>	

## Contacting Supermicro

### Headquarters

Address: Super Micro Computer, Inc.  
980 Rock Ave.  
San Jose, CA 95131 U.S.A.

Tel: +1 (408) 503-8000

Fax: +1 (408) 503-8008

Email: [marketing@supermicro.com](mailto:marketing@supermicro.com) (General Information)  
[support@supermicro.com](mailto:support@supermicro.com) (Technical Support)

Website: [www.supermicro.com](http://www.supermicro.com)

### Europe

Address: Super Micro Computer B.V.  
Het Sterrenbeeld 28, 5215 ML  
's-Hertogenbosch, The Netherlands

Tel: +31 (0) 73-6400390

Fax: +31 (0) 73-6416525

Email: [sales@supermicro.nl](mailto:sales@supermicro.nl) (General Information)  
[support@supermicro.nl](mailto:support@supermicro.nl) (Technical Support)  
[rma@supermicro.nl](mailto:rma@supermicro.nl) (Customer Support)

Website: [www.supermicro.nl](http://www.supermicro.nl)

### Asia-Pacific

Address: Super Micro Computer, Inc.  
3F, No. 150, Jian 1st Rd.  
Zhonghe Dist., New Taipei City 235  
Taiwan (R.O.C)

Tel: +886-(2) 8226-3990

Fax: +886-(2) 8226-3992

Email: [support@supermicro.com.tw](mailto:support@supermicro.com.tw)

Website: [www.supermicro.com.tw](http://www.supermicro.com.tw)

# Chapter 1

## Introduction

### 1.1 Overview

This chapter provides a brief outline of the functions and features of the 5019S-MN4. The 5019S-MN4 is based on the X11SSH-LN4F motherboard and the SC813MFTQC-350CB chassis.

In addition to the motherboard and chassis, several important parts that are included with the system are listed below.

Main Parts List		
Description	Part Number	Quantity
Air Shroud	MCP-310-19007-0N	1
Heatsink (passive)	SNK-P0046P	1
Riser Card	RSC-RR1U-E16	1

### 1.2 Unpacking the System

Inspect the box the SuperServer 5019S-MN4 was shipped in and note if it was damaged in any way. If any equipment appears damaged, please file a damage claim with the carrier who delivered it.

Decide on a suitable location for the rack unit that will hold the server. It should be situated in a clean, dust-free area that is well ventilated. Avoid areas where heat, electrical noise and electromagnetic fields are generated. It will also require a grounded AC power outlet nearby. Be sure to read the precautions and considerations noted in Appendix B.

### 1.3 System Specifications

The following table provides you with an overview of the main features and specifications of the 5019S-MN4. Please refer to Appendix C for additional specifications.

System Specifications
<b>Motherboard</b>
X11SSH-LN4F
<b>Chassis</b>
SC813MFTQC-350CB
<b>CPU</b>
Intel® E3-1200 v5 and 6th Gen Core i3, Pentium and Celeron processors
<b>Socket Type</b>
LGA 1151 (H4)
<b>Memory</b>
Four 288-pin DIMM slots to support up to 64 GB of 72-bit DDR4 unbuffered ECC 2133/1866/1600/1333MHz SDRAM
<b>Chipset</b>
C236 chipset
<b>Expansion Slots</b>
One PCI Express 3.0 x4 in x8 slot (PCH Slot 4) One PCI Express 3.0 x8 (CPU Slot 5) One PCI Express 3.0 x8 in x16 slot (CPU Slot 6) One M.2 Mini PCI Express 3.0 x2 connector
<b>Hard Drives</b>
Four hot-swap SATA hard drives
<b>Power</b>
Single 350W power supply
<b>Form Factor</b>
1U rackmount
<b>Dimensions</b>
(WxHxD) 17.2 x 1.7 x 19.85 in. (437 x 43 x 504 mm)

## 1.4 Server Chassis Features

### Control Panel

The switches and LEDs located on the control panel are described below. See Chapter 4 for more details on the control panel.

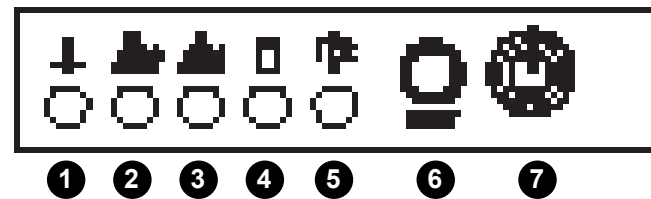

Figure 1-1. Control Panel View

Control Panel Features		
Item	Feature	Description
1	Overheat/Fan Fail LED	When flashing, this LED indicates a fan failure. When on continuously it indicates an overheat condition.
2	NIC2 LED	Indicates network activity on LAN port 2 when flashing
3	NIC1 LED	Indicates network activity on LAN port 1 when flashing
4	HDD LED	Indicates activity on the hard drive when flashing.
5	Power LED	Indicates power is being supplied to the system power supply. This LED should normally be illuminated when the system is operating.
6	Reset Button	The reset button is used to reboot the system
7	Power Button	The main power button is used to apply or remove power from the power supply to the server. Turning off system power with this button removes the main power but maintains standby power. To perform many maintenance tasks, you must also unplug system before servicing

### Front Features

The SC813MFTQC-350CB is a mini 1U chassis. See the illustration below for the features included on the front of the chassis.

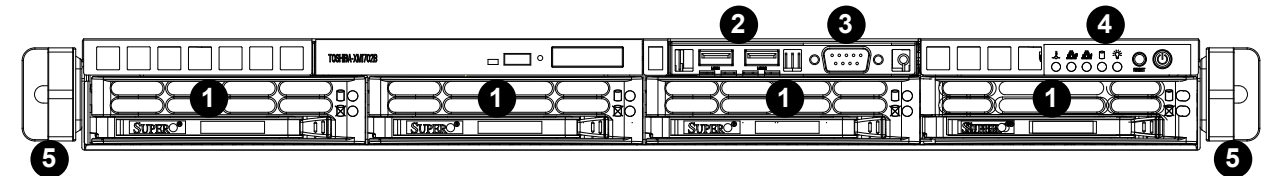

Figure 1-2. Chassis Front View

Front Chassis Features		
Item	Feature	Description
1	SATA HDD	Hot-swap 3.5" SATA hard disk drive
2	USB Ports	Two front-access USB 3.0 ports
3	COM Port	Front-access COM (serial) port
4	Control Panel	Front control panel with LEDs and buttons (see preceding page)
5	Rack Ear Brackets	Attaches server chassis to the rack

## Rear Features

The illustration below shows the features included on the rear of the chassis.

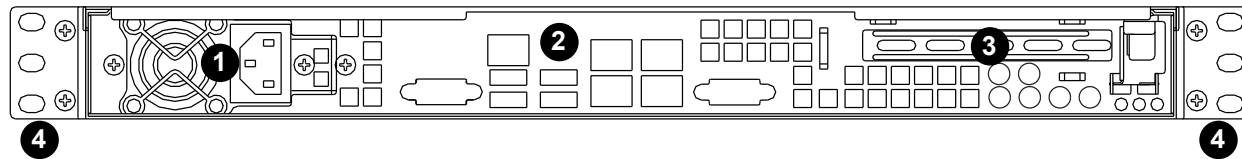

Figure 1-3. Chassis Rear View

Rear Chassis Features		
Item	Feature	Description
1	Power Supply	350W Platinum Level Power Supply (p/n PWS-350-1H)
2	I/O Backpanel	Rear I/O ports (see Section 4.3)
3	Expansion Card Slot	Slot for one expansion card (requires pre-installed riser card)
4	Rack Ear Brackets	Attaches server chassis to the rack

## 1.5 Motherboard Layout

Below is a layout of the X11SSH-LN4F with jumper, connector and LED locations shown. See the table on the following pages for descriptions. For detailed descriptions, pinout information and jumper settings, refer to Chapter 4.

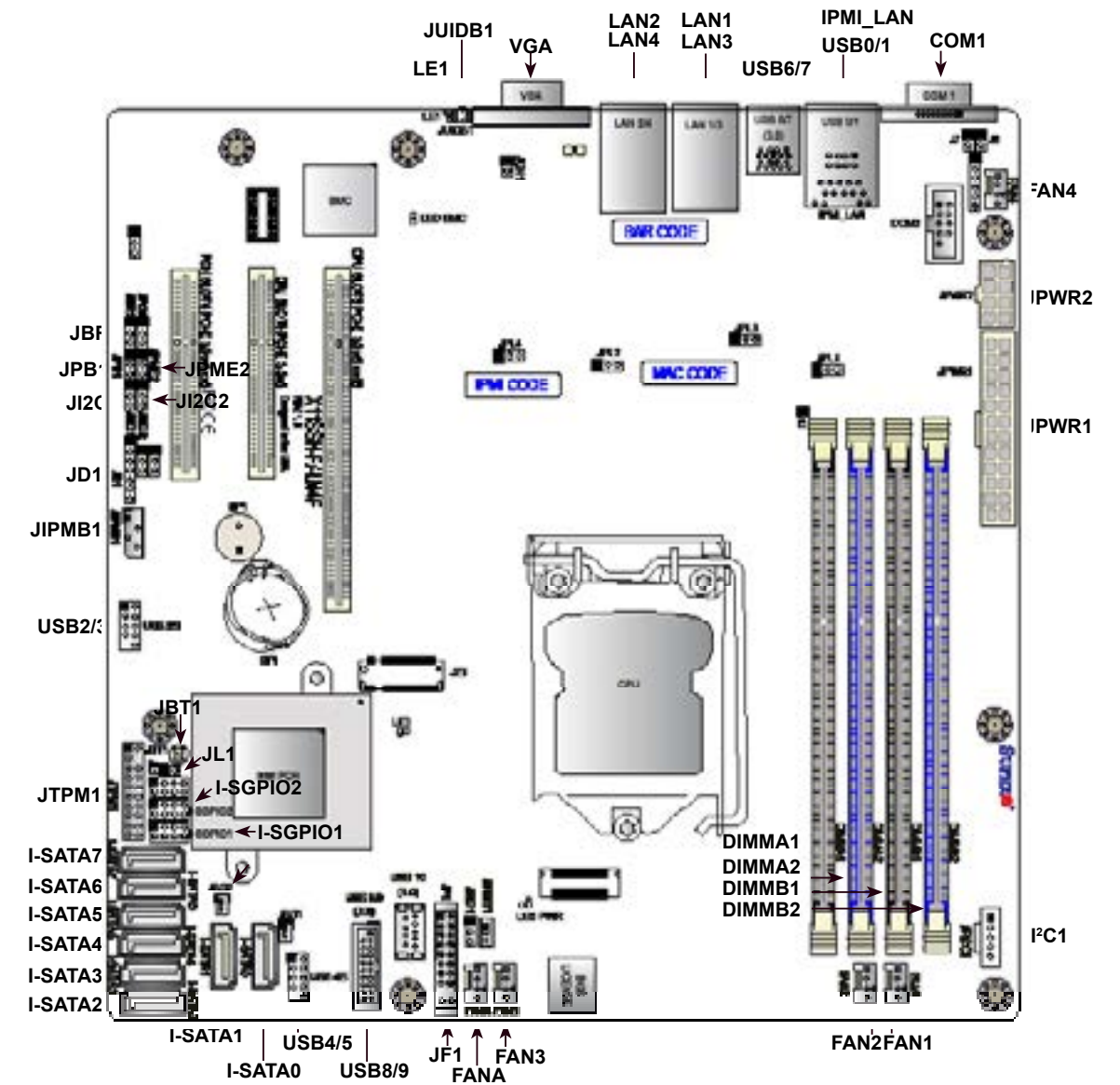

Figure 1-4. Motherboard Layout

## Quick Reference Table

Jumper	Description	Default Setting
J7	LAN4 LINK ACK	Off (Disabled)
J8	LAN3 LINK ACK	Off (Disabled)
JBR1	BIOS Recovery	Pins 1-2 (Normal)
JBT1	Clear CMOS	See Chapter 4
J <sup>2</sup> C1/J <sup>2</sup> C2	SMB to PCI Slots	Pins 2-3 (Disabled)
JPB1	BMC Enable/Disable	Pins 1-2 (Enabled)
JPG1	VGA Enable	Pins 1-2 (Enabled)
JPL1-JPL4	LAN1-LAN4 Enable	Pins 1-2 (Enabled)
JPME2	Manufacturing Mode Select	Pins 1-2 (Normal)
JWD1	Watch Dog Enable	Pins 1-2 (Reset)

LED	Description	Status
LE1	Rear UID LED	Blue: On; Unit identified
LE3	PCI-E 3.0 M.2 LED	Green: Blinking; Active
LEDBMC	BMC Heartbeat LED	Green: Blinking; BMC normal
LEDPWR	Onboard Power LED	Green: Solid on; Power on

Connector	Description
BT1	Onboard Battery
COM1/COM2	COM1/COM2 Port Headers
Fan1-Fan4, FanA	System/CPU Fan Headers
I-SATA0-I-SATA7	SATA 3.0 Connectors via Intel PCH (6Gb/s)
I-SGPIO 1/2	Serial_Link General Purpose I/O Connection Headers 1/2
IPMI_LAN	Dedicated IPMI Gigabit (RJ45) Port
J23	M.2 Socket
JD1	Speaker/Power LED Indicator
JF1	Front Panel Control Header
JIPMB1	4-pin External BMC I <sup>2</sup> C Header (for an IPMI Card)
JL1	Chassis Intrusion Header
JOH1	Overheat LED Indicator
JPI <sup>2</sup> C1	Power I <sup>2</sup> C System Management Bus (Power SMB) Header
JPWR1	24-pin ATX Main Power Connector (Required)
JPWR2	+12V 8-pin CPU power Connector (Required)
JSD1/JSD2	SATA Disk On Module (DOM) Power Connectors
JSTBY1	Wake-On-LAN Enable Header
JTPM1	Trusted Platform Module/Port 80 Connector
JUIDB1	UID (Unit Identification) Switch
LAN1-LAN4	Gigabit (RJ45) LAN Ports

Connector	Description
PCI-E (PCH) Slot 4	PCI-Express 3.0 x4in x8 Slot
PCI-E (CPU) Slot 5	PCI-Express 3.0 x8 Slot
PCI-E (CPU) Slot 6	PCI-Express 3.0 x8 in x16 Slot
SP1	Internal Speaker/Buzzer
USB 0/1	Back Panel USB 2.0 Ports
USB 2/3, USB 4/5	Front Accessible USB 2.0 Headers
USB 6/7	Back Panel USB 3.0 Ports
USB 8/9	Front Accessible USB 3.0 Header
USB 10	USB 3.0 Type-A Header
VGA	Back Panel VGA Port

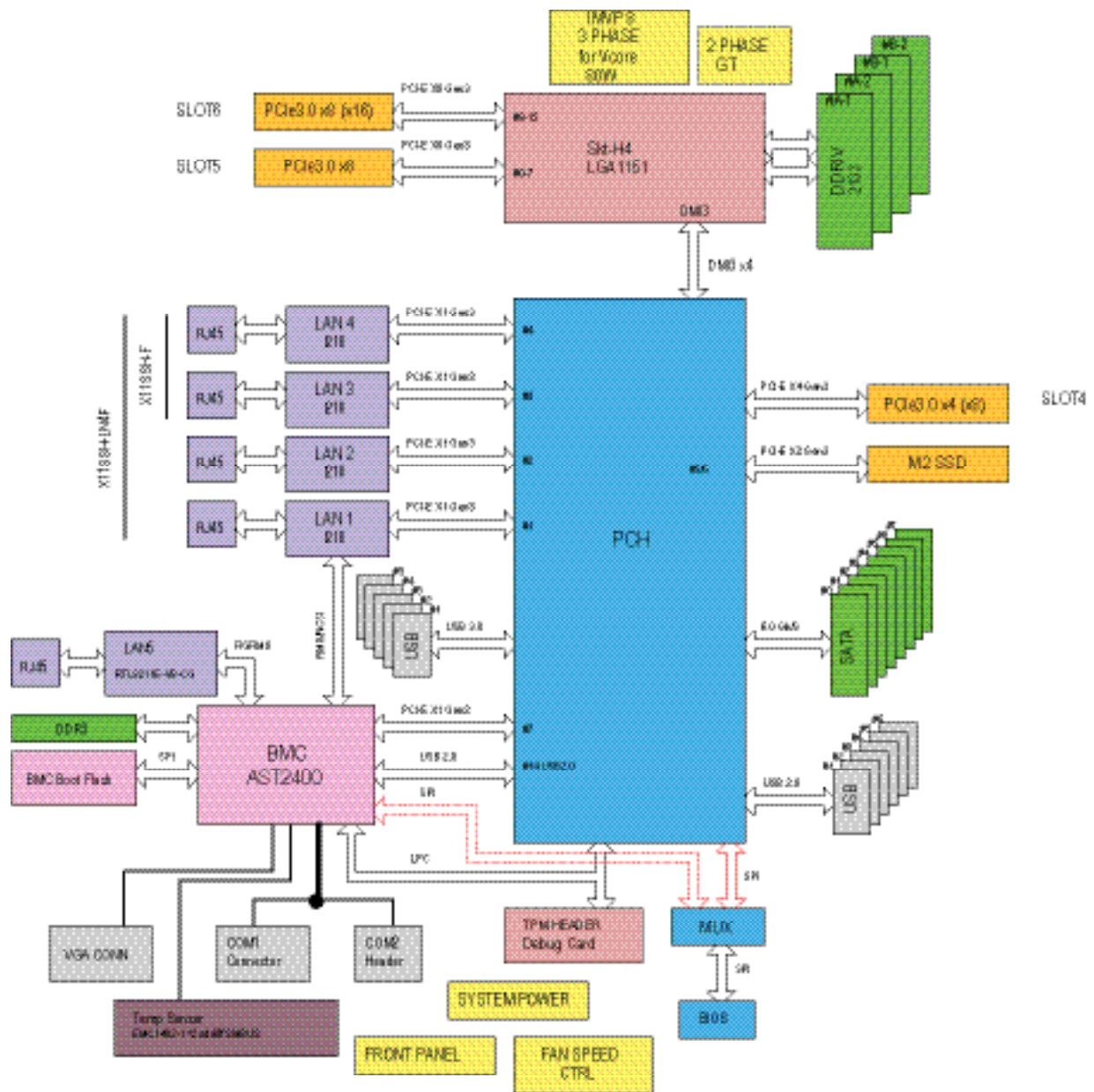

Figure 1-5. C236 Chipset Block Diagram

**Note:** This is a general block diagram and may not exactly represent the features on your motherboard. See the System Specifications appendix for the actual specifications of your motherboard.

# Chapter 2

## Server Installation

### 2.1 Overview

This chapter provides advice and instructions for mounting your system in a server rack. If your system is not already fully integrated with processors, system memory etc., refer to Chapter 4 for details on installing those specific components.

**Caution:** Electrostatic Discharge (ESD) can damage electronic components. To prevent such damage to PCBs (printed circuit boards), it is important to use a grounded wrist strap, handle all PCBs by their edges and keep them in anti-static bags when not in use.

### 2.2 Preparing for Setup

The box in which the system was shipped should include the rackmount hardware needed to install it into the rack. Please read this section in its entirety before you begin the installation.

#### Choosing a Setup Location

- The system should be situated in a clean, dust-free area that is well ventilated. Avoid areas where heat, electrical noise and electromagnetic fields are generated.
- Leave enough clearance in front of the rack so that you can open the front door completely (~25 inches) and approximately 30 inches of clearance in the back of the rack to allow sufficient space for airflow and access when servicing.
- This product should be installed only in a Restricted Access Location (dedicated equipment rooms, service closets, etc.).
- This product is not suitable for use with visual display workplace devices according to §2 of the the German Ordinance for Work with Visual Display Units.

#### Rack Precautions

- Ensure that the leveling jacks on the bottom of the rack are extended to the floor so that the full weight of the rack rests on them.

- In single rack installations, stabilizers should be attached to the rack. In multiple rack installations, the racks should be coupled together.
- Always make sure the rack is stable before extending a server or other component from the rack.
- You should extend only one server or component at a time - extending two or more simultaneously may cause the rack to become unstable.

#### Server Precautions

- Review the electrical and general safety precautions in Appendix B.
- Determine the placement of each component in the rack *before* you install the rails.
- Install the heaviest server components at the bottom of the rack first and then work your way up.
- Use a regulating uninterruptible power supply (UPS) to protect the server from power surges and voltage spikes and to keep your system operating in case of a power failure.
- Allow any drives and power supply modules to cool before touching them.
- When not servicing, always keep the front door of the rack and all covers/panels on the servers closed to maintain proper cooling.

#### Rack Mounting Considerations

##### *Ambient Operating Temperature*

If installed in a closed or multi-unit rack assembly, the ambient operating temperature of the rack environment may be greater than the room's ambient temperature. Therefore, consideration should be given to installing the equipment in an environment compatible with the manufacturer's maximum rated ambient temperature (TMRA).

##### *Airflow*

Equipment should be mounted into a rack so that the amount of airflow required for safe operation is not compromised.

##### *Mechanical Loading*

Equipment should be mounted into a rack so that a hazardous condition does not arise due to uneven mechanical loading.

### **Circuit Overloading**

Consideration should be given to the connection of the equipment to the power supply circuitry and the effect that any possible overloading of circuits might have on overcurrent protection and power supply wiring. Appropriate consideration of equipment nameplate ratings should be used when addressing this concern.

### **Reliable Ground**

A reliable ground must be maintained at all times. To ensure this, the rack itself should be grounded. Particular attention should be given to power supply connections other than the direct connections to the branch circuit (i.e. the use of power strips, etc.).



To prevent bodily injury when mounting or servicing this unit in a rack, you must take special precautions to ensure that the system remains stable. The following guidelines are provided to ensure your safety:

- This unit should be mounted at the bottom of the rack if it is the only unit in the rack.
- When mounting this unit in a partially filled rack, load the rack from the bottom to the top with the heaviest component at the bottom of the rack.
- If the rack is provided with stabilizing devices, install the stabilizers before mounting or servicing the unit in the rack.

## **2.3 Installing the Rails**

There are a variety of rack units on the market, which may require a slightly different assembly procedure.

The following is a basic guideline for installing the system into a rack with the rack mounting hardware provided. You should also refer to the installation instructions that came with the specific rack you are using.

### **Identifying the Rails**

The rack rails and the related hardware should have been included with the system. Refer to Figure 2-1 to identify the rail sections. Note that these two rails are left/right specific

### **Installing the Chassis Rails**

Begin the rack mounting procedure by installing the inner rails to the server chassis.

1. Position the front and rear chassis rail sections along the side of the server making sure the screw holes line up. Note that these two rails are left/right specific.
2. Screw the front chassis rail (the long piece) securely to the side of the chassis (see Figure 2-2). There should be two screws for each side. Repeat this procedure for the other rail on the opposite side of the chassis.
3. Attach the two rear chassis rails to the chassis in the same manner, again keeping in mind that the rails are left/right specific. (You will also need to attach the rail brackets when installing into a telco rack.)



Slide rail mounted equipment is not to be used as a shelf or a work space.



**Warning:** do not pick up the server with the front handles. They are designed to pull the system from a rack only.

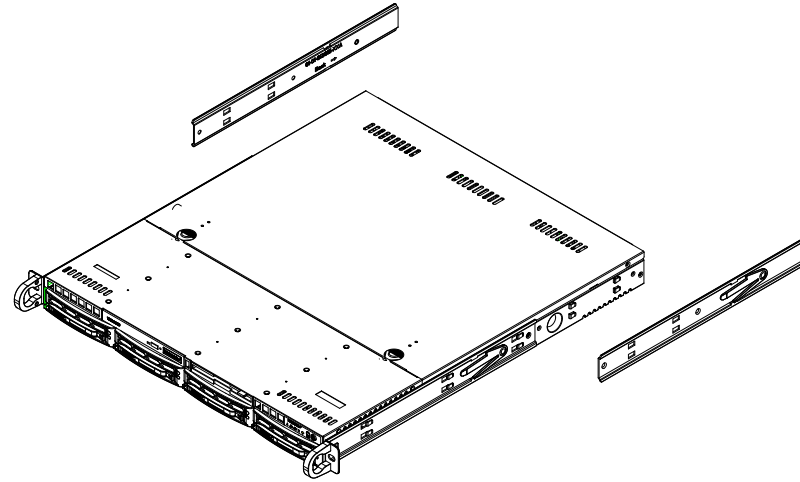

Figure 2-1. Installing the Rear Inner Rails

### Installing the Rack Rails

Determine where you want to place the server in the rack (see the Rack and Server Precautions in Section 2.2). Note that servers should always be installed to the bottom of a rack first for stability reasons.

1. Position the chassis rail guides at the desired location in the rack, keeping the sliding rail guide facing the inside of the rack.
2. Screw the assembly securely to the rack using the brackets provided.
3. Attach the other assembly to the other side of the rack, making sure that both are at the exact same height and with the rail guides facing inward.

**Note:** Both front chassis rails and the rack rails have a locking tab, which serves two functions. First, it locks the server into place when installed and pushed fully into the rack (its normal operating position). In addition, these tabs lock the server in place when fully extended from the rack. This prevents the server from coming completely out of the rack when pulled out for servicing.

## 2.4 Installing the Server into a Rack

You should now have rails attached to both the chassis and the rack. The next step is to install the server into the rack.

1. Line up the rear of the chassis rails with the front of the rack rails.
2. Slide the chassis rails into the rack rails, keeping the pressure even on both sides (you may have to press the locking tabs when inserting). See Figure 2-2.
3. When the server has been pushed completely into the rack, you should hear the locking tabs "click".

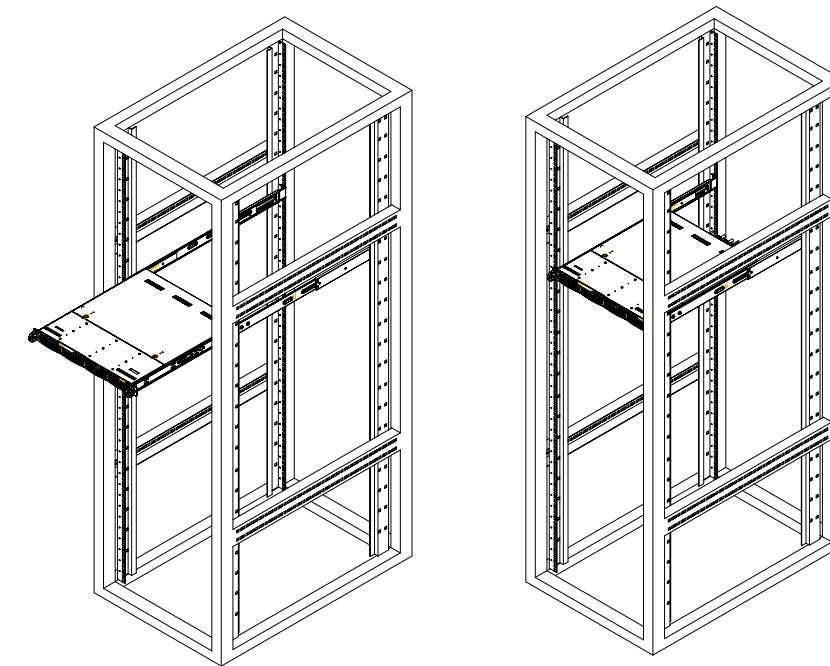

Figure 2-2. Installing the Server into a Rack

**Note:** Figures are for illustrative purposes only. Always install servers to the bottom of a rack first.



**Warning:** Stability hazard. The rack stabilizing mechanism must be in place, or the rack must be bolted to the floor before you slide the unit out for servicing. Failure to stabilize the rack can cause the rack to tip over.

## Installing the Server into a Telco Rack

To install the SuperServer 5019S-MN4 into a Telco (or “open”) type rack, use two L-shaped brackets on either side of the chassis (four total).

1. First, determine how far the server will extend out from the front of the rack. The chassis should be positioned so that the weight is balanced between front and back.
2. Attach the two front brackets to each side of the chassis, then the two rear brackets positioned with just enough space to accommodate the width of the rack.
3. Finish by sliding the chassis into the rack and tightening the brackets to the rack. See Figure 2-4.

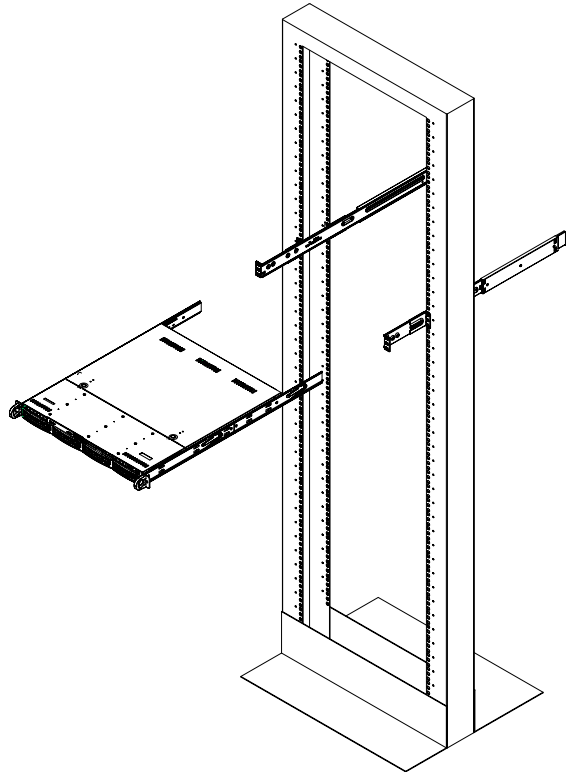

**Figure 2-3. Installing the Server into a Telco Rack**

**Note:** Figure is for illustrative purposes only. Always install servers to the bottom of a rack first.

## Chapter 3

### Maintenance and Component Installation

This chapter provides instructions on installing and replacing main system components. To prevent compatibility issues, only use components that match the specifications and/or part numbers given.

Installation or replacement of most components require that power first be removed from the system. Please follow the procedures given in each section.

#### 3.1 Removing Power

Use the following procedure to ensure that power has been removed from the system. This step is necessary when removing or installing non hot-swap components or when replacing a non-redundant power supply.

1. Use the operating system to power down the system.
2. After the system has completely shut-down, disconnect the AC power cord(s) from the power strip or outlet. (If your system has more than one power supply, remove the AC power cords from all power supply modules)
3. Disconnect the power cord(s) from the power supply module(s).

#### 3.2 Accessing the System

The SC813MFTQC-350CB features a removable top cover, which allows easy access to the inside of the chassis.

##### **Removing the Top Cover**

1. Disconnect the chassis from any power source if necessary (see above).
2. Remove the screws securing the cover to the chassis.
3. Slide the cover toward the rear of the chassis.
4. Lift the cover from the chassis.

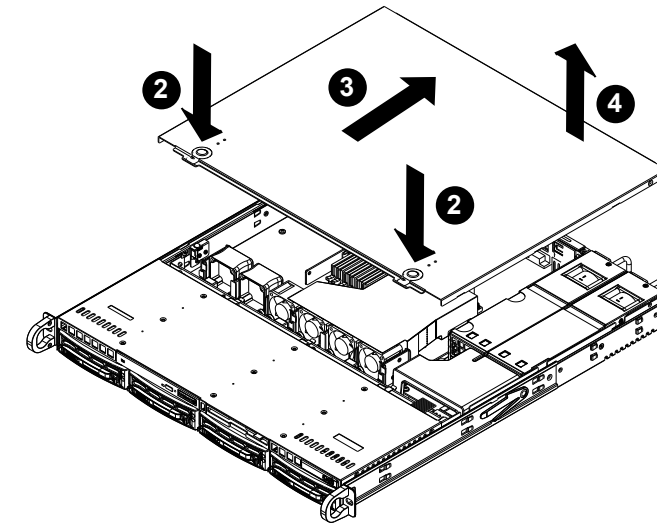

Figure 3-1. Removing the Top Cover

**Note:** the figure above is for illustrative purposes only. The 5019S-MN4 features a single power supply only.

#### 3.3 Motherboard Components

##### **Processor and Heatsink Installation**

Follow the procedures in this section to install a processor (CPU) and heatsink to the motherboard.

##### **Notes:**

- The motherboard should be installed into the chassis first and the processor should be installed into the CPU socket before you install a CPU heatsink.
- If you bought a CPU separately, make sure that you use an Intel-certified multi-directional heatsink only.
- When receiving a motherboard without a processor pre-installed, make sure that the plastic CPU socket cap is in place and none of the socket pins are bent; otherwise, contact your retailer immediately.
- Refer to the Supermicro website for updates on CPU support.

##### **Installing the Processor(s)**

Begin by removing power from the system as described in Section 3.1.

1. Remove the cover plate that protects the CPU#1 socket: press the load lever to release the load plate, which covers the CPU socket, from its locked position.

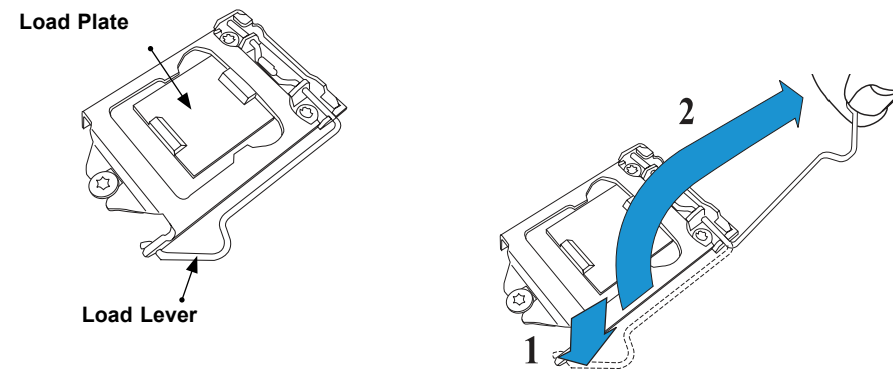

**Figure 3-2. Removing the Processor Cover Plate**

2. Gently lift the load lever to open the load plate. Remove the plastic cover plate.

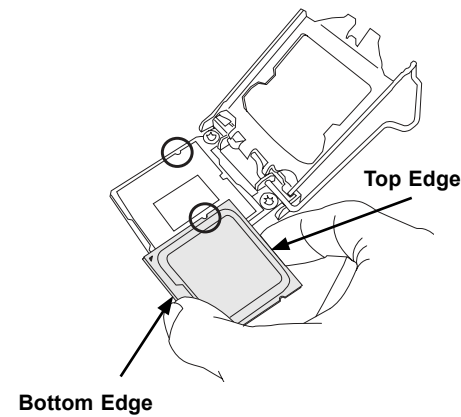

**Figure 3-3. Placing the Processor into the Socket**

3. Use your thumb and your index finger to hold the edges of the processor. Align the CPU key (the semi-circle cutouts) with the socket keys.
4. Once aligned, carefully place the processor into the socket. Do not drop the processor on the socket, move or rub the processor against the socket or against any socket pins, which may damage the components.

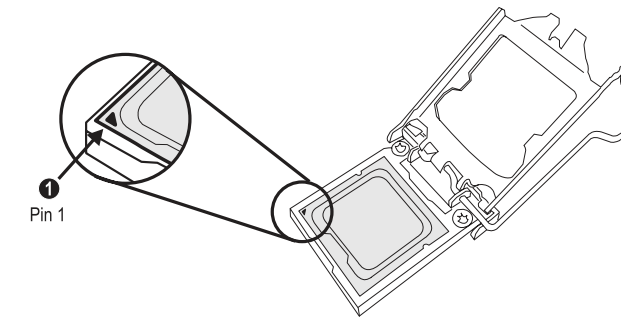

**Figure 3-4. Inspecting the Processor Installation**

5. With the processor inserted into the socket, inspect the four corners of the CPU to make sure that it is properly installed and flush with the socket.

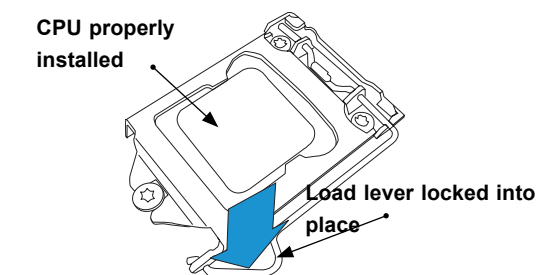

**Figure 3-5. Installing/Removing the Heatsink**

6. Carefully press the processor load lever down until it locks into its retention tab.

#### ***Installing a Heatsink***

A passive type heatsink is used on the X11SSH-LN4F.

**Note:** Do not apply any thermal grease to the heatsink or the CPU die; the required amount has already been applied.

1. Place the heatsink on top of the CPU so that the four mounting holes are aligned with those on the heatsink retention mechanism.
2. Screw in two diagonal screws (i.e. the #1 and the #2 screws) until they are just snug. Do not fully tighten the screws or you may damage the CPU.

3. Add the two remaining screws then finish the installation by fully tightening all four screws (be careful not to overtighten).

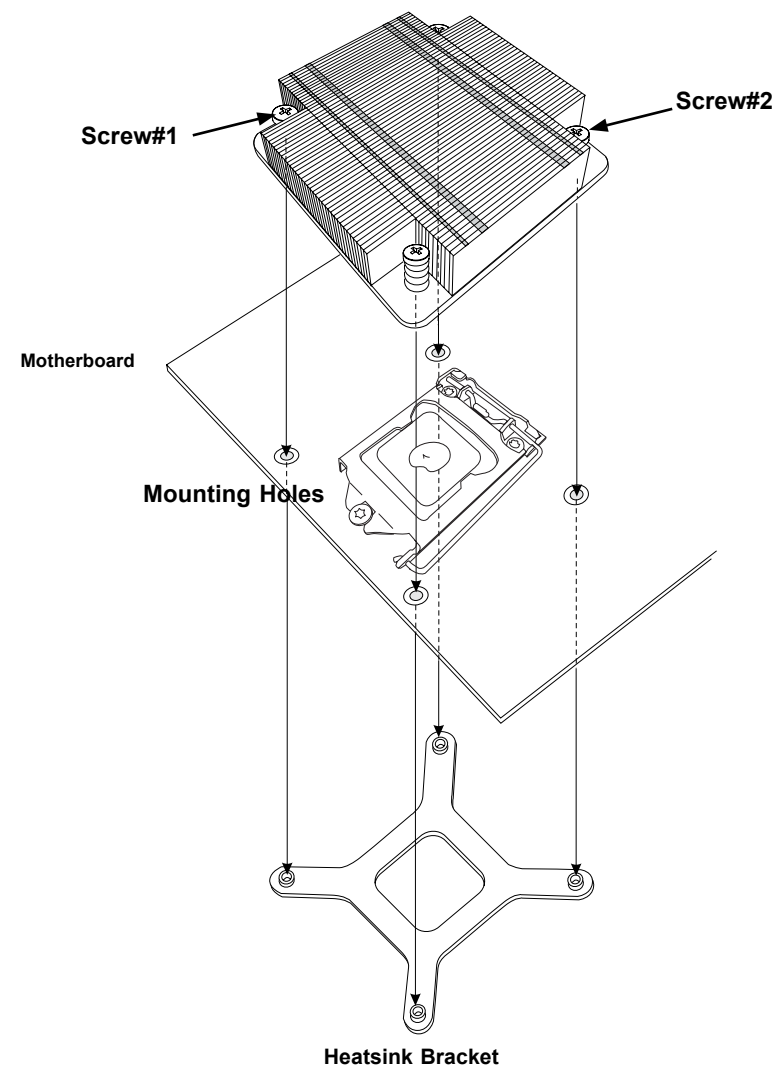

Figure 3-6. Installing the Heatsink

#### Removing a Heatsink

We do not recommend removing the heatsink. If necessary, please follow the instructions below to prevent damage to the CPU or the CPU socket.

1. Unscrew and remove the heatsink screws from the motherboard in the sequence as shown in the figure above.
2. Hold and gently pivot the heatsink back and forth to loosen it from the CPU. (Do not use excessive force when dislodging the heatsink.)

3. Once the heatsink is loose, remove it from the CPU.
4. Clean the surface of the CPU and the heatsink to get rid of the old thermal grease. Reapply the proper amount of thermal grease to the surface before you re-install the heatsink.

**Note:** Wait for the heatsink to cool down before removing it.

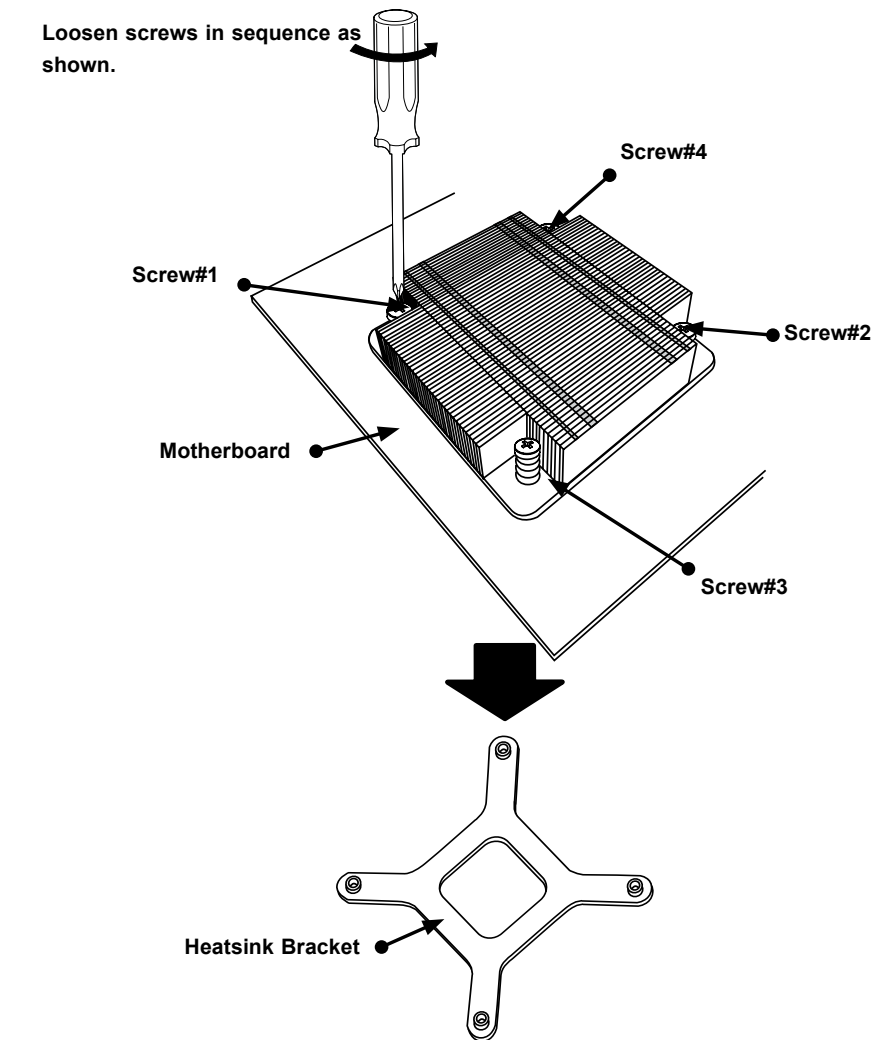

Figure 3-7. Removing the Heatsink

## Memory Installation

### Memory Support

The X11SSH-LN4F supports up to 64GB of ECC DDR4-2133/1866/1600/1333 unbuffered (UDIMM) memory in four memory slots. Populating these DIMM slots with memory modules of the same type and size will result in interleaved memory, which will improve memory performance.

Check the Supermicro website for possible updates to memory support.

### Installing Memory

Begin by removing power from the system as described in Section 3.1.

1. Starting with DIMMB2 (blue slot), push the release tabs outwards on both ends of the DIMM slot to unlock it.
2. Align the key of the DIMM with the receptive point on the memory slot and the notches on both ends of the module with the receptive points on the slot.
3. With your thumbs on both ends of the module, press it straight down into the slot until the module snaps into place.
4. Press the release tabs to the locked positions to secure the DIMM module into the slot. Repeat for other DIMM slots as needed. See next page for population sequence.
5. To remove a DIMM, unlock the release tabs then pull the DIMM from the memory slot.

**Caution:** Exercise extreme caution when installing or removing memory modules to prevent any possible damage to the DIMMs or slots.

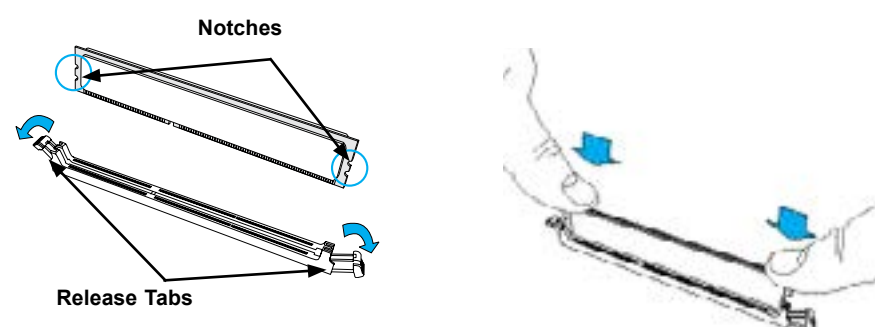

Figure 3-8. Installing DIMMs

**Note:** Visit the product page on the Supermicro website for possible updates to memory support ([www.supermicro.com](http://www.supermicro.com)).

## DIMM Module Population Sequence

When installing memory modules, the DIMM slots should be populated in the following order: DIMMB2, DIMMA2, DIMMB1, DIMMA1.

- Always use DDR4 DIMM modules of the same type, size and speed.
- Mixed DIMM speeds can be installed. However, all DIMMs will run at the speed of the slowest DIMM.
- The motherboard will support odd-numbered modules (1 or 3 modules installed). However, for best memory performance, install DIMM modules in pairs to activate memory interleaving.

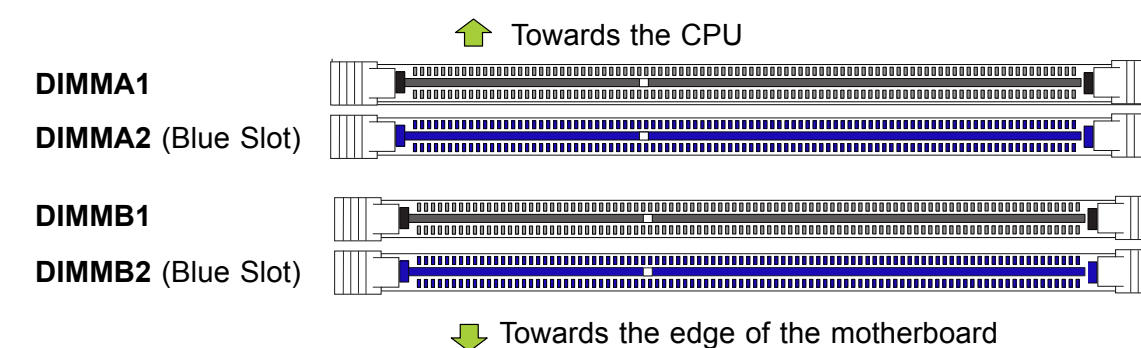

Figure 3-9. Populating DIMMs

## PCI Expansion Card Installation

The system includes a pre-installed riser card (p/n CSE-RR1U-E16) that positions a standard size PCI-E x16 card at a 90 degree angle, allowing it to fit inside the chassis.

### Installing PCI Expansion Cards

The CSE-RR1U-E16 riser card has already been pre installed into the motherboard. Perform the following steps to install an add-on card:

Begin by removing power from the system as described in section 3.1.

1. Remove the chassis cover to access the inside of the system.
2. Remove the PCI slot shield on the chassis by releasing the locking tab.
3. Insert the expansion (add-on) card into the riser card.
4. Secure the card with the locking tab.

## Motherboard Battery

The motherboard uses non-volatile memory to retain system information when system power is removed. This memory is powered by a lithium battery residing on the motherboard.

### Replacing the Battery

Begin by removing power from the system as described in section 3.1.

1. Push aside the small clamp that covers the edge of the battery. When the battery is released, lift it out of the holder.
2. To insert a new battery, slide one edge under the lip of the holder with the positive (+) side facing up. Then push the other side down until the clamp snaps over it.

**Note:** Please handle used batteries carefully. Do not damage the battery in any way; a damaged battery may release hazardous materials into the environment. Do not discard a used battery in the garbage or a public landfill. Please comply with the regulations set up by your local hazardous waste management agency to dispose of your used battery properly.

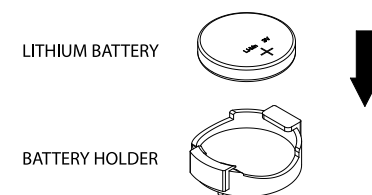

Figure 3-10. Installing the Onboard Battery

**Warning:** There is a danger of explosion if the onboard battery is installed upside down (which reverses its polarities). This battery must be replaced only with the same or an equivalent type recommended by the manufacturer (CR2032).

## 3.4 Chassis Components

### Hard Drives

Your server may or may not have come with hard drives installed. Up to four 3.5" hard drives are supported by the chassis.

The SATA drives are mounted in drive carriers to simplify their installation and removal from the chassis. (Both procedures may be done without removing power from the system.)

#### Removing a Hot-Swap Drive Carrier

1. Push the release button on the carrier.
2. Swing the handle fully out.
3. Grasp the handle and use it to pull the drive carrier out of its bay.

#### Mounting a Drive in a Drive Carrier

1. To add a new drive, install it into the carrier with the printed circuit board side facing down so that the mounting holes align with those in the carrier.
2. Secure the drive to the carrier with the screws provided, then push the carrier completely into the drive bay. You should hear a \*click\* when the drive is fully inserted. This indicates that the carrier has been fully seated and connected to the midplane, which automatically makes the power and logic connections to the hard drive.

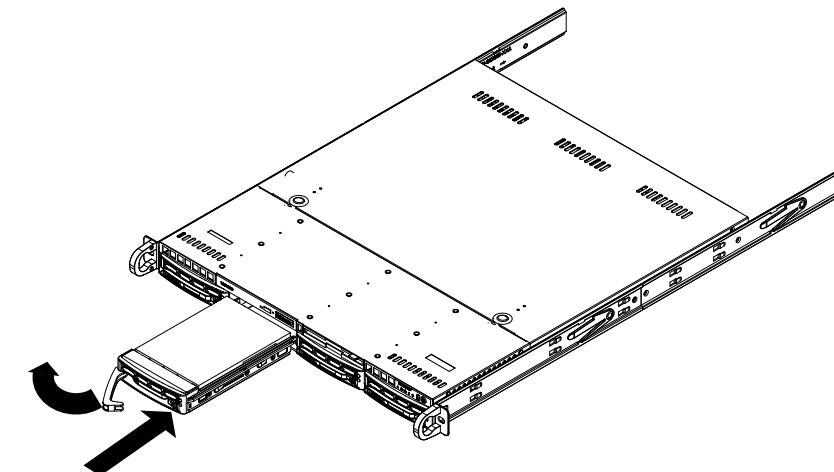
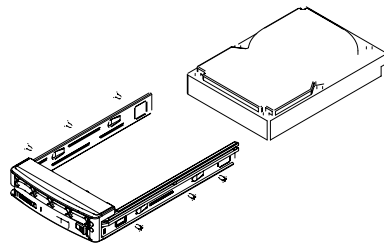

Figure 3-11. Removing a Drive Carrier

**Warning:** Only enterprise level HDDs are recommended for use in the server.

**Removing a Drive from a Drive Carrier**

1. Remove the screws that secure the hard drive to the carrier and separate the hard drive from the carrier.
2. Replace the carrier back into the drive bay.



**Figure 3-12. Mounting a Drive in a Carrier**

**Hard Drive Carrier Indicators**

Each hard drive carrier has two LED indicators: an activity indicator and a status indicator. In RAID configurations, the status indicator lights to indicate the status of the drive. In non-RAID configurations, the status indicator remains off. See the table below for details.

Hard Drive Carrier LED Indicators		
LED	State/Condition	Indication
Green	Blinking	Indicates drive activity
Red	Solid on	Drive failure

**Note:** Enterprise level hard disk drives are recommended for use in Supermicro chassis and servers. For information on recommended HDDs, visit the Supermicro website at <http://www.supermicro.com/products/info/files/storage/SBB-HDDCompList.pdf>

**System Cooling**

Four 4-cm fans provide the cooling for the system. It is very important that the chassis top cover is installed for the cooling air to circulate properly through the chassis and cool the components.

**Installing Fans**

Fan speed is controlled by system temperature via IPMI. If a fan fails, the remaining fans will ramp up to full speed. Replace any failed fan at your earliest convenience with the same type and model (the system can continue to run with a failed fan).

**Replacing a System Fan**

3. If necessary, open the chassis while the power is running to determine which fan requires changing. (Never run the server for an extended period of time with the chassis open.)
4. Power down the system and unplug the AC power cord from the rear of the power supply. Open the chassis cover.
5. Remove the failed fan's cable from the connector on the motherboard.
6. Gently pull upward to remove the failed fan from the housing.
7. Place the new fan into the vacant space in the housing. Make sure that the arrows on the side of the fan (indicating air direction) point in the same direction as the arrows on the other fans.
8. Connect the fan wires to the same fan header as the fan just removed.
9. Plug the power cord into the rear of the power supply, power up the system and check that the fan is working properly before replacing the chassis cover.

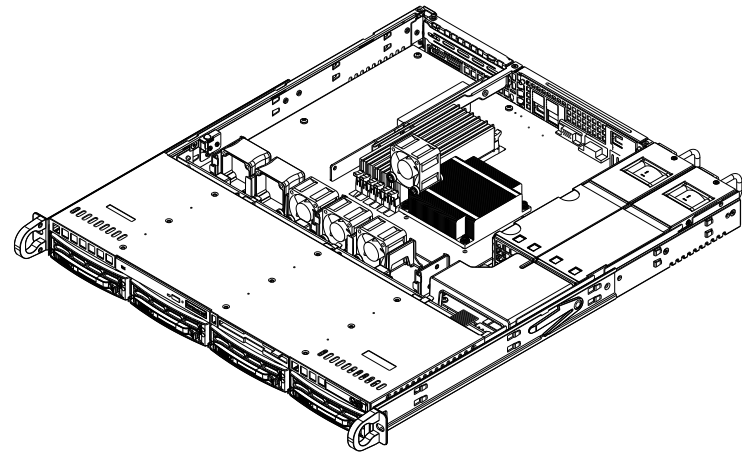

**Figure 3-13. Replacing a System Fan**

**Note:** the figure above is for illustrative purposes only. The 5019S-MN4 features a single power supply only.

### ***Air Shroud***

The air shroud is used to concentrate airflow to maximize fan efficiency. The air shroud does not require screws to set up.

#### ***Installing the Air Shroud***

1. Lay the chassis on a flat, stable surface and remove the chassis cover.
2. If necessary, move any cables that interfere with the air shroud placement.
3. Place the air shroud in the chassis. The air shroud fits just behind the fans. Slide the air shroud into the grooves just behind the fan rack.
4. Reroute any cables that were moved and replace the chassis cover.

### **Power Supply**

The 5019S-MN4 has a single high-efficiency power supply, which is auto-switching capable. This enables it to automatically sense and operate with a 100V to 240V input voltage.

#### ***Power Supply Failure***

If the power supply unit fails, the system will shut down and you will need to replace the unit. Replacement units can be ordered directly from Supermicro (see contact information in the Preface).

#### ***Removing the Power Supply***

Begin by removing power from the system as described in Section 3.1.

1. Releasing the retention screws that secure the chassis to the rack, then grasp the two handles on either side and pull the system straight out until it locks (you will hear a "click").
2. Next, remove the top chassis cover as described in Section 3.2.
3. To remove the failed power unit, remove the two screws on the back and the single screw on the front of the power supply, which secure it to the chassis. You can then lift the unit straight out of the chassis.

#### ***Installing a New Power Supply***

1. Replace the failed power supply with another identical power supply module (exact same model).
2. Carefully insert the new module into position in the chassis and secure it with the three screws you removed previously.
3. Reconnect the AC power cord.
4. Replace the chassis top cover and push the server back into the rack.
5. Finish by pressing the power button on the control panel.

# Chapter 4

## Motherboard Connections

This section describes the connections on the motherboard and provides pinout definitions. Note that depending on how the system is configured, not all connections are required. The LEDs on the motherboard are also described here. A severboard layout indicating component locations may be found in Appendix B.

Please review the Safety Precautions in Chapter 3 before installing or removing components.

### 4.1 Power Connections

Two power connections on the X11SSH-LN4F must be connected to the power supply. The wiring is included with the power supply.

- 24-pin Primary ATX Power (JPWR1)
- 8-pin Processor Power (JPWR2)

#### Main ATX Power Connector

The primary power connector (JPWR1) meets the ATX SSI EPS 12V specification. You must also connect the 8-pin (JPWR2) processor power connector to your power supply (see below).

ATX Power 24-pin Connector Pin Definitions			
Pin#	Definition	Pin#	Definition
13	+3.3V	1	+3.3V
14	-12V	2	+3.3V
15	Ground	3	Ground
16	PS_ON	4	+5V
17	Ground	5	Ground
18	Ground	6	+5V
19	Ground	7	Ground
20	Res (NC)	8	PWR_OK
21	+5V	9	5VSB
22	+5V	10	+12V
23	+5V	11	+12V
24	Ground	12	+3.3V

Required Connection

**Important:** To provide adequate power to the motherboard, connect the 24-pin *and* the 8-pin power connectors to the power supply. Failure to do so may void the manufacturer's warranty on your power supply and motherboard.

#### Processor Power Connector

JPWR2 must also be connected to the power supply. This connector is used to power the processor(s).

+12V 8-pin Power Pin Definitions	
Pin#	Definition
1 - 4	Ground
5 - 8	+12V

Required Connection

### 4.2 Headers and Connectors

#### Fan Headers

There are five fan headers on the motherboard. These are 4-pin fan headers; pins 1-3 are backward compatible with traditional 3-pin fans. The onboard fan speeds are controlled by Thermal Management via IPMI. When using Thermal Management setting, please use all 3-pin fans or all 4-pin fans.

Fan Header Pin Definitions	
Pin#	Definition
1	Ground (Black)
2	2.5A/+12V (Red)
3	Tachometer
4	PWM_Control

#### Power Supply SMBus Header

A Power SMB header is located at PW4. Connect the appropriate cable here to utilize SMB on your system.

Power Supply SMB Header Pin Definitions	
Pin#	Definition
1	Clock
2	Data
3	PWR Fail
4	Ground
5	+3.3V

### Power LED/Speaker

Pins 1-3 of JD1 are used for power LED indication and pins 4-7 are for the speaker. Please note that the speaker connector pins (4-7) are used with an external speaker. If you wish to use the onboard speaker, you should close pins 6-7 with a jumper.

PWR LED Connector Pin Definitions	
Pin Setting	Definition
1	JD1_PIN1
2	FP_PWR_LED
3	FP_PWR_LED

Speaker Connector Pin Definitions	
Pin Setting	Definition
4	P5V
5	Key
6	R_SPKPIN_N
7	R_SPKPIN

### SGPIO Headers

The SGPIO (Serial General Purpose Input/Output) headers are used to communicate with the enclosure management chip on the backplane and support the SATA ports.

I-SGPIO 1/2	
I-SGPIO1	Ports 2-4
I-SGPIO2	Ports 5-7

SGPIO Header Pin Definitions			
Pin#	Definition	Pin#	Definition
1	NC	2	NC
3	GND	4	Data
5	Load	6	GND
7	Clock	8	NC

NC = No Connection

### Disk-On-Module Power Connector

Two power connectors for SATA DOM (Disk On Module) devices are located at JSD1/JSD2. Connect appropriate cables here to provide power support for your Serial Link DOM devices.

DOM Power Pin Definitions	
Pin#	Definition
1	5V
2	Ground
3	Ground

### TPM/Port 80 Header

A Trusted Platform Module (TPM)/Port 80 header is located at JTPM1 to provide TPM support and Port 80 connection. Use this header to enhance system performance and data security.

Trusted Platform Module Header Pin Definitions			
Pin#	Definition	Pin#	Definition
1	LCLK	2	GND
3	LFRAME#	4	<(KEY)>
5	LRESET#	6	+5V
7	LAD3	8	LAD2
9	+3.3V	10	LAD1
11	LAD0	12	GND
13	SMB_CLK	14	SMB_DAT
15	+3V Stdbby	16	SERIRQ
17	GND	18	CLKRUN#
19	LPCPD#	20	LDRQ#

### Standby Power

The Standby Power header is located at JSTBY1 on the motherboard.

Wake-On-LAN Pin Definitions	
Pin#	Definition
1	+5V Standby
2	Ground
3	Wake-up

### Internal Speaker/Buzzer

The Internal Speaker (SP1) can be used to provide audible notifications using various beep codes.

Internal Buzzer Pin Definitions		
Pin#	Polarity	Definition
1	Pos (+)	Beep In
2	Neg (-)	Alarm Speaker

### Power SMB (I<sup>2</sup>C) Header

The Power System Management Bus (I<sup>2</sup>C) connector (JPI<sup>2</sup>C1) monitors the power supply, fan, and system temperatures.

Power SMB Header Pin Definitions	
Pin#	Definition
1	Clock
2	Data
3	PMBUS_Alert
4	Ground
5	+3.3V

### 4-pin BMC External I<sup>2</sup>C Header

A System Management Bus header for IPMI 2.0 is located at JIPMB1. Connect the appropriate cable here to use the IPMB I<sup>2</sup>C connection on your system.

External I <sup>2</sup> C Header Pin Definitions	
Pin#	Definition
1	Data
2	GND
3	Clock
4	NC

### Overheat/Fan Fail LED Header

The JOH1 header is used to connect an LED indicator to provide warnings of chassis overheating and fan failure. This LED will blink when a fan failure occurs.

Overheat LED Header Status	
State	Definition
Solid	Overheat
Blinking	Fan Fail

Overheat LED Pin Definitions	
Pin#	Definition
1	5vDC
2	OH Active

### Chassis Intrusion

A Chassis Intrusion header is located at JL1 on the motherboard. Attach the appropriate cable from the chassis to inform you of a chassis intrusion when the chassis is opened.

Chassis Intrusion Pin Definitions	
Pin#	Definition
1	Intrusion Input
2	Ground

### M.2 Slot

The X11SSH-LN4F contains one M.2 socket at J23. M.2 was formerly Next Generation Form Factor (NGFF) and serves to replace mini PCI-E and mSATA. M.2 allows for a greater variety of card sizes, increased functionality, and spatial efficiency.

The M.2 socket on the X11SSH-LN4F motherboard supports PCI-E 3.0 x2 M.2 cards in the 22x80mm form factor.

### Unit Identifier Switch/UID LED Indicator

A rear Unit Identifier (UID) switch and a rear UID LED (LED1) are located next to the VGA port on the motherboard. The front UID switch and the front UID LED are both located on the Front Panel Control (JF1) (with the front UID switch on pin 13, and the front LED on pin 7 of JF1). When you press the front or the rear UID switch, both front and rear UID LEDs will be turned on. Press the UID switch again to turn off the LED indicators. The UID Indicators provide easy identification of a system unit that may be in need of service.

**Note:** UID can also be triggered via IPMI on the motherboard. For more information on IPMI, please refer to the IPMI User's Guide posted on our website at <http://www.supermicro.com>.

UID Switch Pin Definitions	
Pin#	Definition
1	Ground
2	Ground
3	Button In
4	Ground

UID LED Pin Definitions	
Color	Status
Blue: On	Unit Identified

### Control Panel

JF1 contains header pins for various control panel connections. See the figure below for the pin locations and definitions of the control panel buttons and LED indicators.

All JF1 wires have been bundled into a single cable to simplify this connection. Make sure the red wire plugs into pin 1 as marked on the motherboard. The other end connects to the control panel PCB board.

Figure 4-1. JF1: Control Panel Pins

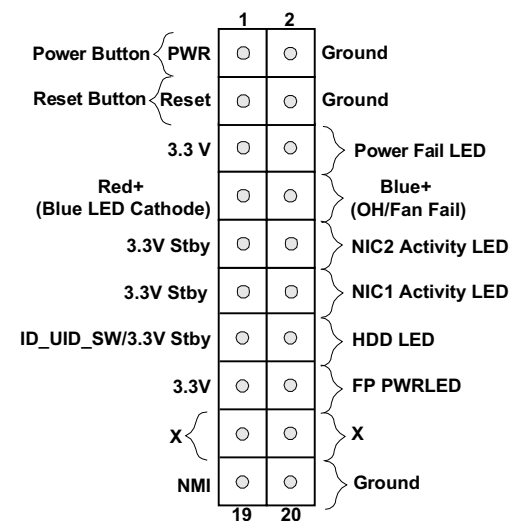

### Power Button

The Power Button connection is located on pins 1 and 2 of JF1. Momentarily contacting both pins will power on/off the system. This button can also be configured to function as a suspend button (with a setting in the BIOS - see Chapter 7). To turn off the power when the system is in suspend mode, press the button for 4 seconds or longer.

Power Button Pin Definitions (JF1)	
Pin#	Definition
1	Signal
2	Ground

### Reset Button

The Reset Button connection is located on pins 3 and 4 of JF1. Attach it to a hardware reset switch on the computer case.

Reset Button Pin Definitions (JF1)	
Pin#	Definition
3	Reset
4	Ground

### Power Fail LED

The Power Fail LED connection is located on pins 5 and 6 of JF1.

Power Fail LED Pin Definitions (JF1)	
Pin#	Definition
5	3.3V
6	PWR Supply Fail

### Overheat (OH)/Fan Fail

Connect an LED cable to pins 7 and 8 of JF1 to use the Overheat/Fan Fail LED connections. The LED on pin 8 provides warnings of overheat or fan failure.

OH/Fan Fail Indicator Status	
Status	Definition
Off	Normal
On	Overheat
Flashing	Fan Fail

OH/Fan Fail LED Pin Definitions (JF1)	
Pin#	Definition
7	Blue LED
8	OH/Fan Fail LED

**NIC1/NIC2 (LAN1/LAN2)**

The NIC (Network Interface Controller) LED connection for LAN port 1 is located on pins 11 and 12 of JF1, and the LED connection for LAN Port 2 is on Pins 9 and 10. Attach the NIC LED cables here to display network activity.

LAN1/LAN2 LED Pin Definitions (JF1)	
Pin#	Definition
9	3.3V Standby
10	NIC2 Activity LED
11	3.3V Standby
12	NIC1 Activity LED

**HDD LED/UID Switch**

The HDD LED/UID Switch connection is located on pins 13 and 14 of JF1. Attach a cable to Pin 14 to show hard drive activity status. Attach a cable to Pin 13 to use UID switch. Refer to the table below for pin definitions.

HDD LED Pin Definitions (JF1)	
Pin#	Definition
13	3.3V Standby/UID Switch
14	HDD Active

**Power LED**

The Power LED connection is located on pins 15 and 16 of JF1.

Power LED Pin Definitions (JF1)	
Pin#	Definition
15	3.3V
16	Power LED

**NMI Button**

The non-maskable interrupt button header is located on pins 19 and 20 of JF1.

NMI Button Pin Definitions (JF1)	
Pin#	Definition
19	Control
20	Ground

**Data Cables**

The data cables in the system have been carefully routed to maintain airflow efficiency. If you disconnect any of these cables, take care to re-route them as they were originally when reconnecting them.

**Important!** Make sure the the cables do not come into contact with the fans.

**Power Cables**

Three power connections on the X11SSH-LN4F must be connected to the power supply. The wiring is included with the power supply.

- 24-pin Primary ATX Power (JPWR1)
- 8-pin Processor Power (JPWR2)

### 4.3 Ports

#### Serial Ports

Two COM ports (COM1 & COM2) are located on the motherboard. COM1 is a port located on the I/O back panel. COM2 is a header located next to COM1.

#### SATA Ports

The X11SSH-LN4F includes a total of eight SATA ports, supported by the Intel C236 PCH chip. These SATA ports support RAID 0, 1, 5, and 10.

**Notes:** I-SATA0 and I-SATA1 are Supermicro SuperDOMs. These are yellow SATADOM ports with power pins built in and do not require separate external power cables. These ports are backward-compatible with non-Supermicro SATADOMs that do require external power.

For more information on the SATA HostRAID configuration, please refer to the Intel SATA HostRAID user's guide posted on our website at <http://www.supermicro.com>.

#### Rear I/O Ports

See the figure below for the locations and descriptions of the various I/O ports on the rear of the motherboard.

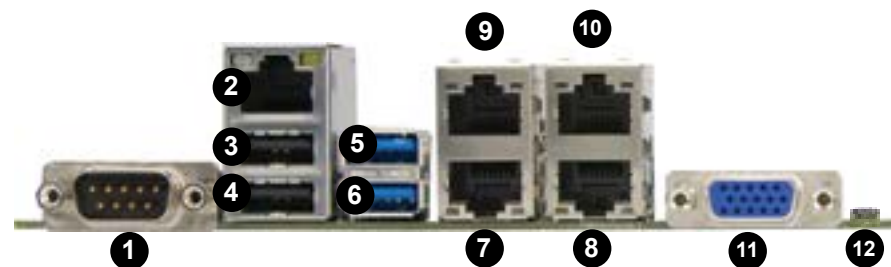

Figure 4-2. Rear I/O Ports

Rear I/O Ports					
#	Description	#	Description	#	Description
1.	COM1 Port	5	USB7 (3.0)	9	LAN3 Port
2.	IPMI LAN Port	6	USB6 (3.0)	10	LAN4 Port
3	USB1 (2.0)	7	LAN1 Port	11	VGA Port
4	USB0 (2.0)	8	LAN2 Port	12	UID Switch

#### Universal Serial Bus (USB) Ports

There are two USB 2.0 ports (USB 0/1) and two USB 3.0 ports (USB 6/7) located on the rear I/O panel. The X11SSH-LN4F also has two front access USB 2.0 headers (USB2/3 and USB4/5) and one front access USB 3.0 header (USB8/9). USB10 is a Type A 3.0 header. The onboard headers can be used to provide front side USB access with a cable (not included).

Back Panel USB 0/1 (2.0) Pin Definitions			
Pin#	Definition	Pin#	Definition
1	+5V	5	+5V
2	USB_N	6	USB_N
3	USB_P	7	USB_P
4	Ground	8	Ground

Front Panel USB 2/3, 4/5 (2.0) Pin Definitions			
Pin#	Definition	Pin#	Definition
1	+5V	2	+5V
3	USB_N	4	USB_N
5	USB_P	6	USB_P
7	Ground	8	Ground
9	Key	10	NC

Front Panel USB 6/7 (3.0) Pin Definitions			
Pin#	Definition	Pin#	Definition
A1	VBUS	B1	Power
A2	D-	B2	USB_N
A3	D+	B3	USB_P
A4	GND	B4	GND
A5	Stda_SSRX-	B5	USB3_RN
A6	Stda_SSRX+	B6	USB3_RP
A7	GND	B7	GND
A8	Stda_SSTX-	B8	USB3_TN
A9	Stda_SSTX+	B9	USB3_TP

Back Panel USB 8/9 (3.0) Pin Definitions			
Pin#	Definition	Pin#	Definition
1	VBUS	19	Power
2	Stda_SSRX-	18	USB3_RN
3	Stda_SSRX+	17	USB3_RP
4	GND	16	GND
5	Stda_SSTX-	15	USB3_TN
6	Stda_SSTX+	14	USB3_TP
7	GND	13	GND
8	D-	12	USB_N
9	D+	11	USB_P
10			

Type A USB 10 (3.0) Pin Definitions			
Pin#	Definition	Pin#	Definition
1	VBUS	5	SSRX-
2	USB_N	6	SSRX+
3	USB_P	7	GND
4	Ground	8	SSTX-
		9	SSTX+

### VGA Port

A video (VGA) port is located next to LAN2 on the I/O back panel.

### LAN Ports

Four Gigabit Ethernet ports are located on the rear I/O panel of the motherboard. In addition, a dedicated IPMI LAN port is located above the USB 0/1 ports. All of these ports accept RJ45 cables. Please refer to the LED Indicator section for LAN LED information.

## 4.4 Jumpers

### Explanation of Jumpers

To modify the operation of the motherboard, jumpers are used to choose between optional settings. Jumpers create shorts between two pins to change the function associated with it. Pin 1 is identified with a square solder pad on the printed circuit board. See the motherboard layout page for jumper locations.

**Note:** On a two-pin jumper, "Closed" means the jumper is on both pins and "Open" indicates the jumper is either on only one pin or has been completely removed.

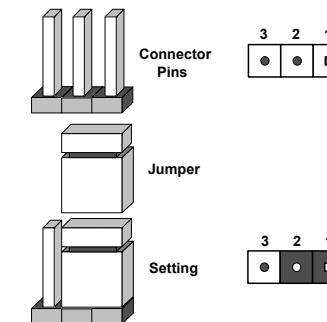

### CMOS Clear

JBT1 is used to clear CMOS, which will also clear any passwords. Instead of pins, this jumper consists of contact pads to prevent accidentally clearing the contents of CMOS.

#### To Clear CMOS

1. First power down the system and unplug the power cord(s).
2. Remove the cover of the chassis to access the motherboard.
3. Remove the onboard battery from the motherboard.
4. Short the CMOS pads with a metal object such as a small screwdriver for at least four seconds.
5. Remove the screwdriver (or shorting device).
6. Replace the cover, reconnect the power cord(s) and power on the system.

**Notes:** Clearing CMOS will also clear all passwords.

Do not use the PW\_ON connector to clear CMOS.



**VGA Enable/Disable**

JPG1 allows you to enable or disable the VGA port. The default setting is Enabled.

VGA Enable/Disable Jumper Settings	
Jumper Setting	Definition
Pins 1-2	Enabled
Pins 2-3	Disabled

**LAN1/2 Enable/Disable**

Change the setting of jumper JPL1 and JPL2 to enable or disable the LAN1 and LAN2 Ethernet ports, respectively. The default setting is Enabled.

LAN1/2 Enable/Disable Jumper Settings	
Jumper Setting	Definition
Pins 1-2	Enabled
Pins 2-3	Disabled

**Watch Dog**

JWD controls the Watch Dog function. Watch Dog is a monitor that can reboot the system when a software application hangs. Jumping pins 1-2 will cause Watch Dog to reset the system if an application hangs. Jumping pins 2-3 will generate a non-maskable interrupt signal for the application that hangs. Watch Dog must also be enabled in BIOS. The default setting is Reset.

**Note:** When Watch Dog is enabled, the user needs to write their own application software to disable it.

Watch Dog Jumper Settings	
Jumper Setting	Definition
Pins 1-2	Reset
Pins 2-3	NMI
Open	Disabled

**BIOS Recovery**

Use jumper JBR1 to recover the BIOS settings on the motherboard. The default setting is Normal.

BIOS Recovery Jumper Settings	
Jumper Setting	Definition
Pins 1-2	Normal
Pins 2-3	BIOS Recovery

**SMBus to PCI Slots**

Use jumpers JI<sup>2</sup>C1 and JI<sup>2</sup>C2 to connect the System Management Bus (I2C) to PCI-Express slots to improve PCI performance. These two jumpers should be set to the same setting. The default setting is Disabled.

I <sup>2</sup> C for PCI-E Slots Jumper Settings	
Jumper Setting	Definition
Pins 1-2	Enabled
Pins 2-3	Disabled

**BMC Enabled**

Jumper JPB1 allows you to enable the embedded ASpeed AST2400 Baseboard Management Controller (BMC) to provide IPMI 2.0/KVM support on the motherboard. The default setting is BMC Enable.

BMC Enable Jumper Settings	
Jumper Setting	Definition
Pins 1-2	BMC Enabled
Pins 2-3	Disabled

**Manufacturer Mode Select**

Close pins 2 and 3 of jumper JPME2 to bypass SPI flash security and force the system to operate in the manufacturer mode, which will allow the user to flash the system firmware from a host server for system setting modifications. The default setting is Normal.

Manufacturer Mode Jumper Settings	
Jumper Setting	Definition
Pins 1-2	Normal
Pins 2-3	Manufacturer Mode

## 4.5 LED Indicators

### LAN LEDs

Two LAN ports are located on the rear I/O panel of the motherboard. Each Ethernet LAN port has two LEDs. The green LED indicates activity, while the other Link LED may be green, amber, or off to indicate the speed of the connection.

LAN1-4 Activity LED (Right) LED State		
Color	Status	Definition
Yellow	Flashing	Active

LAN1-4 Link LED (Left) LED State	
LED Color	Definition
Off	No Connection/10 Mbps
Amber	1 Gbps
Green	100 Mbps

### Dedicated IPMI LAN LEDs

An IPMI LAN is also located on the rear I/O panel. The LED on the right indicates activity, while the LED on the left indicates the speed of the connection.

IPMI LAN LEDs		
LED	Color/State	Definition
Link (left)	Green: Solid	100 Mbps
	Amber: Solid	1Gbps
Activity (Right)	Amber: Blinking	Active

### LAN3/LAN4 Front Panel Activity LEDs

The front panel NIC (Network Interface Connection) activity LED indicators for LAN3/LAN4 are located at J7/J8.

### BMC Heartbeat LED

A BMC Heartbeat LED is located at LEDBMC on the motherboard. When LEDBMC is blinking, the BMC is functioning normally.

Onboard Power LED Indicator	
LED Color	Definition
Green: Blinking	BMC: Normal

### Onboard Power LED

The Onboard Power LED is located at LEDPWR. When this LED is on, the system is on. Be sure to turn off the system and unplug the power cord before removing or installing components.

Onboard Power LED Indicator	
LED Color	Definition
Off	System Off (power cable not connected)
Green	System On

### M.2 LED

An M.2 LED is located at LE3 on the motherboard. When LE3 is blinking, M.2 is functioning normally.

M.2 LED State	
LED Color	Definition
Green: Blinking	Device Working

## Chapter 5

### Software

After the hardware has been installed, you should install the Operating System (OS), configure RAID settings and install the drivers. Necessary drivers and utilities may be found at <ftp://ftp.supermicro.com/driver>.

#### 5.1 OS Installation

You must first configure RAID settings (if using RAID) before you install the Windows OS and the software drivers. To configure RAID settings, please refer to the RAID Configuration User Guides posted on our website at [www.supermicro.com/support/manuals](http://www.supermicro.com/support/manuals).

##### Installing the Windows OS for a RAID System

1. Insert Microsoft's Windows Setup DVD in the DVD drive and the system will start booting up from the DVD.
2. Insert the USB stick containing Windows drivers to a USB port on the system.  
**Note:** for older legacy OS's, please use a method to slipstream the drivers.
3. Select the partition on the drive in which to install Windows.
4. Browse the USB folder for the proper driver files.
5. Choose the RAID driver indicated in the Windows OS Setup screen, then choose the hard drive in which you want to install it.
6. Once all devices are specified, continue with the installation.
7. After the Windows OS installation is completed, the system will automatically reboot.

##### Installing Windows to a Non-RAID System

1. Insert Microsoft's Windows OS Setup DVD in the DVD-ROM drive and the system will start booting up from the DVD.
2. Continue with the installation. The Windows OS Setup screen will display.
3. From the Windows OS Setup screen, press the <Enter> key. The OS Setup will automatically load all device files and then continue with the Windows installation.
4. After the installation has completed, the system will automatically reboot.

#### 5.2 Driver Installation

The Supermicro FTP site contains drivers and utilities for your system at <ftp://ftp.supermicro.com>. Some of these must be installed, such as the chipset driver.

After accessing the FTP site, go into the CDR\_Images directory and locate the ISO file for your motherboard. Download this file to create a DVD of the drivers and utilities it contains. (You may also use a utility to extract the ISO file if preferred.)

After creating a DVD with the ISO files, insert the disk into the DVD drive on your system and the display shown in Figure 5-1 should appear.

Another option is to go to the Supermicro website at <http://www.supermicro.com/products/>. Find the product page for your motherboard here, where you may download individual drivers and utilities to your hard drive or a USB flash drive and install from there.

**Note:** To install the Windows OS, please refer to the instructions posted on our website at <http://www.supermicro.com/support/manuals/>.



Figure 5-1. Driver & Tool Installation Screen

**Note:** Click the icons showing a hand writing on paper to view the readme files for each item. Click the computer icons to the right of these items to install each item (from top to the bottom) one at a time. **After installing each item, you must re-boot the system before moving on to the next item on the list.** The bottom icon with a CD on it allows you to view the entire contents.

### 5.3 SuperDoctor® 5

The Supermicro SuperDoctor 5 is a program that functions in a command-line or web-based interface for Windows and Linux operating systems. The program monitors such system health information as CPU temperature, system voltages, system power consumption, fan speed, and provides alerts via email or Simple Network Management Protocol (SNMP).

SuperDoctor 5 comes in local and remote management versions and can be used with Nagios to maximize your system monitoring needs. With SuperDoctor 5 Management Server (SSM Server), you can remotely control power on/off and reset chassis intrusion for multiple systems with SuperDoctor 5 or IPMI. SuperDoctor 5 Management Server monitors HTTP, FTP, and SMTP services to optimize the efficiency of your operation.

**Note:** The default User Name and Password for SuperDoctor 5 is admin / admin.

**Figure 5-2. SuperDoctor 5 Interface Display Screen (Health Information)**



### 5.4 IPMI

The X11SSH-LN4F support the Intelligent Platform Management Interface (IPMI). IPMI is used to provide remote access, monitoring and management. There are several BIOS settings that are related to IPMI.

For general documentation and information on IPMI, please visit our website at: <http://www.supermicro.com/products/nfo/IPMI.cfm>.

## Chapter 6

### BIOS

#### 6.1 Introduction

This chapter describes the AMIBIOS™ setup utility for the X11SSH-LN4F motherboard. The BIOS is stored on a Flash EEPROM and can be easily upgraded using a flash program.

**Note:** Due to periodic changes to the BIOS, some settings may have been added or deleted and might not yet be recorded in this manual. Please refer to the Manual Download area of our website for any changes to BIOS that may not be reflected in this manual.

##### Starting the Setup Utility

To enter the BIOS setup utility, enter the <Delete> key while the system is booting up. (In most cases, the <Delete> key is used to invoke the BIOS setup screen. There are a few cases when other keys are used, such as <F1>, <F2>, etc.) Each main BIOS menu option is described in this manual.

The main BIOS screen has two main frames. The left frame displays all the options that can be configured. “Grayed-out” options cannot be configured. The right frame displays the key legend. Above the key legend is an area reserved for a text message. When an option is selected in the left frame, it is highlighted in white. Often a text message will accompany it. Note that BIOS has default text messages built in. We retain the option to include, omit, or change any of these text messages. Settings printed in **Bold** are the default values.

A " ►" indicates a submenu. Highlighting such an item and pressing the <Enter> key will open the list of settings within that submenu.

The BIOS setup utility uses a key-based navigation system called hot keys. Most of these hot keys (<F1>, <F4>, <Enter>, <ESC>, <Arrow> keys, etc.) can be used at any time during the setup navigation process.

**Note 1:** Options printed in **Bold** are default settings.

**Note 2:** <F3> is used to load optimal default settings. <F4> is used to save the settings and exit the setup utility.

#### How To Change the Configuration Data

The configuration data that determines the system parameters may be changed by entering the AMI BIOS setup utility. This setup utility can be accessed by pressing <Delete> at the appropriate time during system boot.

**Note:** For AMI UEFI BIOS Recovery, please refer to the UEFI BIOS Recovery User Guide posted at <http://www.supernmicro.com/support/manuals/>.

#### 6.2 Main Setup

When you first enter the AMI BIOS setup utility, you will enter the Main setup screen. You can always return to the Main setup screen by selecting the Main tab on the top of the screen. The Main BIOS setup screen is shown below. The following Main menu items will display:





immediately and allow the drives that are attached to these host adaptors to function as bootable disks. If this item is set to Postponed, the ROM BIOS of the host adaptors will not capture Interrupt 19 immediately and allow the drives attached to these adaptors to function as bootable devices at bootup. The options are **Immediate** and Postponed.

#### Re-try Boot

If this item is enabled, the BIOS will automatically reboot the system from a specified boot device after its initial boot failure. The options are **Disabled**, Legacy Boot, and EFI Boot.

### ►Power Configuration

#### Watch Dog Function

If enabled, the Watch Dog Timer will allow the system to reset or generate NMI based on jumper settings when the system is inactive more than 5 minutes. The options are Enabled and **Disabled**.

#### Power Button Function

This feature controls how the system shuts down when the power button is pressed. Select 4\_Seconds\_Override for the user to power off the system after pressing and holding the power button for 4 seconds or longer. Select Instant Off to instantly power off the system as soon as the user presses the power button. The options are 4 Seconds Override and **Instant Off**.

#### Restore on AC Power Loss

Use this feature to set the power state after a power outage. Select Stay-Off for the system power to remain off after a power loss. Select Power-On for the system power to be turned on after a power loss. Select Last State to allow the system to resume its last power state before a power loss. The options are Power-On, Stay-Off and **Last State**.

### ►CPU Configuration

The following CPU information will display:

#### CPU Signature

- Intel® Xeon® CPU E3-1280 v5 @3.70GHz
- CPU Signature
- Microcode Patch
- Max CPU Speed
- Min CPU Speed

- CPU Speed
- Processor Cores
- Hyper Threading Technology
- Intel VT-x Technology
- Intel SMX Technology
- 64-bit
- EIST Technology
- CPU C3 State
- CPU C6 State
- CPU C7 State
- L1 Data Cache
- L1 Code Cache
- L2 Cache
- L3 Cache
- L4 Cache

#### Hyper-threading (Available when supported by the CPU)

Select Enabled to support Intel Hyper-threading Technology to enhance CPU performance. The options are **Enabled** and Disabled.

#### Active Processor Cores

This feature determines how many CPU cores will be activated for each CPU. When all is selected, all cores in the CPU will be activated. (Please refer to Intel's web site for more information.) The options are **All** 1,2, and 3.

#### Intel® Virtualization Technology

Select Enable to use Intel Virtualization Technology so that I/O device assignments will be reported directly to the VMM (Virtual Memory Management) through the DMAR ACPI Tables. This feature offers fully-protected I/O resource-sharing across the Intel platforms, providing

the user with greater reliability, security and availability in networking and data-sharing. The settings are **Enabled** and Disabled.

#### Hardware Prefetcher (Available when supported by the CPU)

If set to Enabled, the hardware prefetcher will prefetch streams of data and instructions from the main memory to the L2 cache to improve CPU performance. The options are Disabled and **Enabled**.

#### Adjacent Cache Line Prefetch (Available when supported by the CPU)

Select Disabled for the CPU prefetcher to prefetch the cache line for 64 bytes. Select Enabled for the CPU prefetcher to prefetch both cache lines for 128 bytes as comprised. The options are **Enabled** and Disabled.

#### CPU AES

Select Enabled to enable Intel CPU Advanced Encryption Standard (AES) Instructions for CPU to enhance data integrity. The options are **Enabled** and Disabled.

#### Boot Performance Mode

This feature allows the user to select the performance state that the BIOS will set before the operating system handoff. The options are Power Saving, **Max Non-Turbo Performance** and Turbo Performance.

#### HardWare P-States (HWP)

Use this feature to enable or disable hardware P-States support. The options are **Disabled** and Enabled.

#### Intel® SpeedStep™

Intel SpeedStep Technology allows the system to automatically adjust processor voltage and core frequency to reduce power consumption and heat dissipation. The options are Disabled and **Enabled**.

#### Turbo Mode

Select Enabled for processor cores to run faster than the frequency specified by the manufacturer. The options are Disabled and **Enabled**.

#### Package Power Limit MSR Lock

Select Enabled to lock the package power limit for the model specific registers. The options are **Disabled** and Enabled.

#### Power Limit 1 Override

Select Enabled to support average power limit (PL1) override. The default setting is **Disabled**.

#### Power Limit 2 Override

Select Enabled to support rapid power limit (PL2) override. The default setting is **Enabled**.

#### Power Limit 2

Use this item to configure the value for Power Limit 2. The value is in milli watts and the step size is 125mW. Use the number keys on your keyboard to enter the value. Enter 0 to use the manufacture default setting. If the value is 0, the BIOS will set PL2 as 1.25\* TDP. Enter **0** to use the manufacture default setting.

#### 1-Core Ratio Limit Override

This increases (multiplies) 1 clock speed in the CPU core in relation to the bus speed when one CPU core is active. Press "+" or "-" on your keyboard to change the value. Enter **0** to use the manufacture default setting.

#### 2-Core Ratio Limit Override

This increases (multiplies) 2 clock speeds in the CPU core in relation to the bus speed when two CPU cores are active. Press "+" or "-" on your keyboard to change the value. Enter **0** to use the manufacture default setting.

#### 3-Core Ratio Limit Override

This increases (multiplies) 3 clock speeds in the CPU core in relation to the bus speed when three CPU cores are active. Press "+" or "-" on your keyboard to change the value. Enter **0** to use the manufacture default setting.

#### 4-Core Ratio Limit Override

This increases (multiplies) 4 clock speeds in the CPU core in relation to the bus speed when three CPU cores are active. Press "+" or "-" on your keyboard to change the value. Enter **0** to use the manufacture default setting.

#### CPU C-States

Use this feature to enable the C-State of the CPU. The options are Disabled and **Enabled**.

#### Enhanced C-States

Use this feature to enable the enhanced C-State of the CPU. The options are Disabled and **Enabled**.

#### C-State Auto Demotion

Use this feature to prevent unnecessary excursions into the C-states to improve latency. The options are Disabled, C1, C3, and **C1 and C3**.

#### C-State Un-Demotion

This feature allows the user to enable or disable the un-demotion of C-State. The options are Disabled, C1, C3, and **C1 and C3**.

**Package C-State Demotion**

Use this feature to enable or disable the Package C-State demotion. The options are **Disabled** and **Enabled**.

**Package C-State Un-Demotion**

Use this feature to enable or disable the Package C-State un-demotion. The options are **Disabled** and **Enabled**.

**C-State Pre-Wake**

This feature allows the user to enable or disable the C-State Pre-Wake. The options are **Disabled** and **Enabled**.

**Package C-State Limit**

Use this feature to set the Package C-State limit. The options are C0/C1, C2, C3, C6, C7, C7s, C8, and **AUTO**.

**►CPU Thermal Configuration****CPU DTS**

Select **Enabled** for the ACPI thermal management to use the DTS SMM mechanism to obtain CPU temperature values. Select **Disabled** for EC to report the CPU temperature values. The options are **Disabled** and **Enabled**.

**ACPI 3.0 T-States**

Select **Enabled** to support CPU throttling by the operating system to reduce power consumption. The options are **Enabled** and **Disabled**.

**►Chipset Configuration**

**Warning:** Setting the wrong values in the following features may cause the system to malfunction.

**►System Agent (SA) Configuration**

The following System Agent information will display:

- System Agent Bridge Name
- SA PCIe Code Version
- VT-d

**VT-d**

Select **Enabled** to enable Intel Virtualization Technology support for Direct I/O VT-d by reporting the I/O device assignments to VMM through the DMAR ACPI Tables. This feature offers fully-protected I/O resource-sharing across the Intel platforms, providing the user with greater reliability, security and availability in networking and data-sharing. The options are **Enabled** and **Disabled**.

**Gaussian Mixture Model**

This feature is to enable or disable the System Agent Gaussian Mixture Model device. The options are **Enabled** and **Disabled**.

**►Graphics Configuration**

The following graphics information will display:

- IGFX BIOS Version

**Graphics Turbo IMON Current**

Use this feature to set the limit on the current voltage regulator. Press "+" or "-" on your keyboard to change this value. The default setting is **31**.

**Primary Display**

Use this feature to select the graphics device to be used as the primary display. The options are **Auto**, **PEG**, and **PCI-E**.

**Primary PEG (PCI-Express Graphics)**

This feature allows the user to specify which graphics card to be used as the primary graphics card. The options are **CPU SLOT6 PCI-E 3.0 X8 (INX16)** and **CPU SLOT5 PCI-E 3.0 X8**.

**Primary PCIe (PCI-Express Graphics)**

This feature allows the user to specify which graphics card to be used as the primary graphics card. The options are **Onboard** and **PCI-E 3.0 M.2**.

**►DMI/OPI Configuration**

The following DMI information will display:

- DMI

**DMI VC1 Control**

Use this feature to enable or disable DMI Virtual Channel 1. The options are Enabled and **Disabled**.

**DMI VCm Control**

Use this feature to enable or disable the DMI Virtual Channel map. The options are **Enabled** and Disabled.

**DMI Link ASPM Control**

Use this feature to set the ASPM (Active State Power Management) state on the SA (System Agent) side of the DMI Link. The options are Disabled and **L1**.

**DMI Extended Sync Control**

Use this feature to enable or disable the DMI extended synchronization. The options are **Disabled** and Enabled.

**DMI De-Emphasis Control**

Use this feature to configure the De-emphasis control on DMI. The options are -6dB and **-3.5dB**.

**► PEG Port Configuration****CPU SLOT6 PCI-E 3.0 X8 (IN x16)****SLOT6 Max Link Speed**

This feature allows the user to select PCI-E support for the device installed on SLOT6. The options are **Auto**, Gen 1, Gen 2, and Gen 3.

**SLOT6 Max Payload Size**

Use this feature to select the PEG0 maximum payload size. The options are **Auto**, 128 TLP, and 256 TLP.

**SLOT6 Power Limit Value**

Use this feature to set the upper limit on the power supplied by the PCIE slot. Press "+" or "-" on your keyboard to change this value. The default setting is **75**.

**SLOT6 Power Limit Scale**

Use this feature to select the scale used for the slot power limit value. The options are **1.0x**, 0.1x, 0.01x, and 0.001x.

**Program PCIe ASPM After OPROM**

PCIe ASPM, the Active State Power Management for PCI-Express slots, is a power management protocol used to manage power consumption of serial-link devices installed on PCI-Exp slots during a prolonged off-peak time. If this item is set to Enabled, PCI-E ASMP will be programmed after OPROM. If this item is set to Disabled, the PCI-E ASPM will be programmed before OPROM. The options are **Disabled** and Enabled.

**► Memory Configuration**

The following memory information will display:

- Memory RC Version
- Memory Frequency
- Total Memory
- VDD
- DIMMA1
- DIMMA2
- DIMMB1
- DIMMB2
- Memory Timings (tCL-tRCD-tRP-tRAS)

**Maximum Memory Frequency**

Use this feature to set the maximum memory frequency for onboard memory modules. The options are **Auto**, 1067, 1200, 1333, 1400, 1600, 1800, 1867, 2000, 2133, 2200, and 2400.

**Max TOLUD**

This feature sets the maximum TOLUD value, which specifies the "Top of Low Usable DRAM" memory space to be used by internal graphics devices, GTT Stolen Memory, and TSEG, respectively, if these devices are enabled. The options are **Dynamic**, 1 GB, 1.25 GB, 1.5 GB, 1.75 GB, 2 GB, 2.25 GB, 2.5 GB, 2.75 GB, 3 GB, 3.25 GB, and 3.5 GB.

**Energy Performance Gain**

Use this feature to enable or disable the energy performance gain. The options are **Disabled** and Enabled.

**Memory Scrambler**

Select Enabled to enable memory scrambler support. The options are Disabled and **Enabled**.

**Fast Boot**

Use this feature to enable or disable fast path through the memory reference code. The options are **Enabled** and Disabled.

**REFRESH\_2X\_MODE**

Use this feature to select the refresh mode. The options are **Disabled**, 1-Enabled for WARM or HOT, and 2-Enabled HOT only.

**Closed Loop Thermal Throttling Management**

Select Enabled to support Closed-Loop Thermal Throttling which will improve reliability and reduces CPU power consumption via automatic voltage control while the CPU are in idle states. The options are Disabled and **Enabled**.

**►GT - Power Management Control**

The following GT - Power Management Control information will display:

- GT Info

**RC6 (Render Standby)**

Select Enabled to enable render standby support. The options are Disabled and **Enabled**.

**►PCH-IO Configuration**

The following PCH-IO information will display:

- Intel PCH RC Version
- Intel PCH SKU Name
- Intel PCH Rev ID

**►PCI Express Configuration****DMI Link ASPM Control**

Use this feature to set the ASPM (Active State Power Management) state on the SA (System Agent) side of the DMI Link. The options are Disabled and **Enabled**.

**Peer Memory Write Enable**

Use this feature to enable or disable peer memory write. The options are **Disabled** or Enabled.

**►PCH SLOT4 PCI-E 3.0 X4 (IN X8)****SLOT4 ASPM**

Use this item to set the Active State Power Management (ASPM) level for the PCI-E device installed on the slot specified. Select Auto for the system BIOS to automatically set the ASPM level based on the system configuration. Select Disabled to disable ASPM support. The options are Disabled, L0s, L1, L0s & L1, and **Auto**.

**SLOT4 L1 Substates**

Use this feature to configure the PCI Express L1 Substates. The options are Disabled, L1.1, L1.2, and **L1.1 & L1.2**

**SLOT4 PCIe Speed**

Use this feature to select the PCI Express port speed. The options are **Auto**, Gen1, Gen2, and Gen3.

**SLOT4 Detect Non-Compliance**

Select Enabled for the AMI BIOS to automatically detect a PCI-E device that is not compliant with the PCI-E standards. The options are **Disabled** and Enabled.

**►PCI Express Configuration****Port 61h bit-4 Emulation**

Select Enabled to enable the emulation of Port 61h bit-4 toggling in SMM (System Management Mode). The options are Disabled and **Enabled**.

**PCIe PLL SSC**

Select Enabled to enable Phase Locked Loop (PLL) support on the Spread Spectrum Clock (SSC) settings to help reduce Electromagnetic Interference caused by the components in the system. Select Disabled to enhance system stability. The options are **Disabled** and Enabled

**►SATA Configuration**

When this submenu is selected, the AMI BIOS automatically detects the presence of the SATA devices that are supported by the Intel PCH chip and displays the following items:

**SATA Controller(s)**

This item enables or disables the onboard SATA controller supported by the Intel PCH chip. The options are **Enabled** and Disabled.

**SATA Mode Selection**

Use this item to select the mode for the installed SATA drives. The options are **AHCI** and **RAID**.

**SATA Frozen**

Use this item to enable the HDD Security Frozen Mode. The options are **Enabled** and **Disabled**.

*\*If the item above "Configure SATA as" is set to AHCI, the following items will display:*

**SATA Port 0~ Port 7**

This item displays the information detected on the installed SATA drive on the particular SATA port.

**Port 0~ Port 7**

The status of a SATA port will be displayed as detected by the BIOS.

**Port 0 ~ Port 7 Software Preserve**

The status of software preserve of a SATA port will display as it is detected by the BIOS.

**Port 0 ~ Port 7 Hot Plug**

This feature designates the port specified for hot plugging. Set this item to **Enabled** for hot-plugging support, which will allow the user to replace a SATA disk drive without shutting down the system. The options are **Enabled** and **Disabled**.

**Port 0 ~ Port 7 Spin Up Device**

On an edge detect from 0 to 1, set this item to allow the PCH to initialize the device. The options are **Enabled** and **Disabled**.

**Port 0 ~ Port 7 SATA Device Type**

Use this item to specify if the SATA port specified by the user should be connected to a Solid State drive or a Hard Disk Drive. The options are **Hard Disk Drive** and **Solid State Drive**.

*\*If the item above "SATA Mode Selection" is set to RAID, the following items will display:*

**SATA RAID Option ROM/UEFI Driver**

Select **UEFI** to load the EFI driver for system boot. Select **Legacy** to load a legacy driver for system boot. The options are **Legacy ROM** and **UEFI Driver**.

**SATA Frozen**

Use this item to enable the HDD Security Frozen Mode. The options are **Enabled** and **Disabled**.

**SATA Port 0~ Port 7**

This item displays the information detected on the installed SATA drive on the particular SATA port.

**Port 0~ Port 7**

The status of a SATA port will be displayed as detected by the BIOS.

**Port 0 ~ Port 7 Software Preserve**

The status of software preserve of a SATA port will display as it is detected by the BIOS.

**Port 0 ~ Port 7 Hot Plug**

This feature designates the port specified for hot plugging. Set this item to **Enabled** for hot-plugging support, which will allow the user to replace a SATA disk drive without shutting down the system. The options are **Enabled** and **Disabled**.

**Port 0 ~ Port 7 Spin Up Device**

On an edge detect from 0 to 1, set this item to allow the PCH to initialize the device. The options are **Enabled** and **Disabled**.

**Port 0 ~ Port 7 SATA Device Type**

Use this item to specify if the SATA port specified by the user should be connected to a Solid State drive or a Hard Disk Drive. The options are **Hard Disk Drive** and **Solid State Drive**.

**►PCI/PCI/PnP Configuration**

The following information will display:

PCI Bus Driver Version

PCI Devices Common Settings:

**PCI Latency Timer**

Use this feature to set the latency Timer of each PCI device installed on a PCI bus. Select **32** to set the PCI latency to 32 PCI clock cycles. The options are **32 PCI Bus Clocks**, **64 PCI Bus Clocks**, **96 PCI Bus Clocks**, **128 PCI Bus Clocks**, **160 PCI Bus Clocks**, **192 PCI Bus Clocks**, **224 PCI Bus Clocks**, and **248 PCI Bus Clocks**.

**PCI PERR/SERR Support**

Select **Enabled** to support PERR (PCI/PCI-E Parity Error)/SERR (System Error) runtime error reporting for a PCI/PCI-E slot. The options are **Enabled** and **Disabled**.

**Above 4G Decoding (Available if the system supports 64-bit PCI decoding)**

Select **Enabled** to decode a PCI device that supports 64-bit in the space above 4G Address. The options are **Enabled** and **Disabled**.

**PCH SLOT4 PCI-E 3.0 X4 (IN X8) OPROM**

Use this feature to select which firmware type to be loaded for the add-on card in this slot for system boot. The options are Disabled, **Legacy**, and EFI.

**PCH SLOT5 PCI-E 3.0 X8 OPROM**

Use this feature to select which firmware type to be loaded for the add-on card in this slot for system boot. The options are Disabled, **Legacy**, and EFI.

**PCH SLOT6 PCI-E 3.0 X8 (IN X16) OPROM**

Use this feature to select which firmware type to be loaded for the add-on card in this slot for system boot. The options are Disabled, **Legacy**, and EFI.

**Onboard LAN Option ROM Type**

Select Enabled to enable Option ROM support to boot the computer using a network device specified by the user. The options are **Legacy** and EFI.

**Onboard LAN1 Option ROM**

Use this option to select the type of device installed in LAN Port1 used for system boot. The default setting for LAN1 Option ROM is **PXE**.

**Onboard LAN2 Option ROM/Onboard LAN3 Option ROM/Onboard LAN4 Option ROM (LAN3 Option ROM/Onboard LAN4 Option ROM: Available on the X11SSH-LN4F only)**

Use this option to select the type of device installed in a LAN port specified by user for system boot. The default setting for this item is **Disabled**.

**Onboard Video Option ROM**

Use this item to select the Onboard Video Option ROM type. The options are Disabled, **Legacy**, and EFI.

**VGA Priority**

Use this item to select the graphics device to be used as the primary video display for system boot. The options are **Onboard** and Offboard.

**Network Stack**

Select Enabled to enable PXE (Preboot Execution Environment) or UEFI (Unified Extensible Firmware Interface) for network stack support. The options are **Enabled** and Disabled.

**IPv4 PXE Support**

Select Enabled to enable IPv4 PXE boot support. The options are **Enabled** and Disabled.

**IPv6 PXE Support**

Select Enabled to enable IPv6 PXE boot support. The options are Enabled and **Disabled**.

**PXE boot wait time**

Use this option to specify the wait time to press the ESC key to abort the PXE boot. Press "+" or "-" on your keyboard to change the value. The default setting is **0**.

**Media detect count**

Use this option to specify the number of times media will be checked. Press "+" or "-" on your keyboard to change the value. The default setting is **1**.

**► Super IO Configuration**

The following Super IO information will display:

- AMI SIO Driver Version

**Super IO Chip Logical Device(s) Configuration****► Serial Port 1****► Serial Port 1 Configuration**

This submenu allows the user the configure settings of Serial Port 1.

**Serial Port 1**

Select Enabled to enable the selected onboard serial port. The options are **Enabled** and Disabled.

**Logical Device Settings**

This item displays the current status of a serial part specified by the user.

**Serial Port 1 Change Settings**

This feature specifies the base I/O port address and the Interrupt Request address of a serial port specified by the user. Select Auto to allow the BIOS to automatically assign the base I/O and IRQ address.

The options for Serial Port 1 are **Use Automatic Settings**, (IO=3F8h; IRQ=4; DMA), (IO=3F8h; IRQ=3, 4, 5, 7, 9, 10, 11, 12; DMA), (IO=2F8h; IRQ=3, 4, 5, 7, 9, 10, 11, 12; DMA), (IO=3E8h; IRQ=3, 4, 5, 7, 9, 10, 11, 12; DMA), and (IO=2E8h; IRQ=3, 4, 5, 7, 9, 10, 11, 12; DMA).

**► Serial Port 2****► Serial Port 2 Configuration**

This submenu allows the user the configure settings of Serial Port 2.

**Serial Port 2**

Select Enabled to enable the selected onboard serial port. The options are **Enabled** and Disabled.

### Logical Device Settings

This item displays the current status of a serial port specified by the user.

### Serial Port 2 Change Settings

This feature specifies the base I/O port address and the Interrupt Request address of a serial port specified by the user. Select Auto to allow the BIOS to automatically assign the base I/O and IRQ address.

The options for Serial Port 2 are **Use Automatic Settings**, (IO=2F8h; IRQ=3; DMA), (IO=3F8h; IRQ=3, 4, 5, 7, 9, 10, 11, 12; DMA), (IO=2F8h; IRQ=3, 4, 5, 7, 9, 10, 11, 12; DMA), (IO=3E8h; IRQ=3, 4, 5, 7, 9, 10, 11, 12; DMA), and (IO=2E8h; IRQ=3, 4, 5, 7, 9, 10, 11, 12; DMA).

### Serial Port 2 Attribute

Select SOL to use COM Port 2 as a Serial\_Over\_LAN (SOL) port for console redirection. The options are COM and **SOL**.

The options for Serial Port 4 are **Use Automatic Settings**, (IO=248h; IRQ=7; DMA), (IO=240h; IRQ=3, 4, 5, 7, 9, 10, 11, 12; DMA), (IO=248h; IRQ=3, 4, 5, 7, 9, 10, 11, 12; DMA), (IO=250h; IRQ=3, 4, 5, 7, 9, 10, 11, 12; DMA), and (IO=258h; IRQ=3, 4, 5, 7, 9, 10, 11, 12; DMA).

## ►Intel Server Platform Services

Intel Server Platform Services Configuration

The following items will display as detected by the BIOS:

- ME BIOS Interface Version
- SPS Version
- ME FW (Firmware) Status Value
- ME FW (Firmware) State
- ME FW (Firmware) Operation State
- ME FW (Firmware) Error Code
- ME NM FW (Firmware) Status Value
- BIOS Booting Mode
- Cores Disabled
- ME FW (Firmware) SKU Information
- End-of POST Status

## ►Serial Port Console Redirection

### COM1 Console Redirection

#### Console Redirection

Select Enabled to enable console redirection support for a serial port specified by the user. The options are Enabled and **Disabled**. If this feature is set to Enabled, the following items will become available:

### ►COM1 Console Redirection Settings

This feature allows the user to specify how the host computer will exchange data with the client computer, which is the remote computer used by the user.

#### COM1 Terminal Type

This feature allows the user to select the target terminal emulation type for Console Redirection. Select VT100 to use the ASCII Character set. Select VT100+ to add color and function key support. Select ANSI to use the Extended ASCII Character Set. Select VT-UTF8 to use UTF8 encoding to map Unicode characters into one or more bytes. The options are ANSI, VT100, **VT100+**, and VT-UTF8.

#### COM1 Bits Per second

Use this feature to set the transmission speed for a serial port used in Console Redirection. Make sure that the same speed is used in the host computer and the client computer. A lower transmission speed may be required for long and busy lines. The options are 9600, 19200, 38400, 57600, and **115200** (bits per second).

#### COM1 Data Bits

Use this feature to set the data transmission size for Console Redirection. The options are 7 Bits and **8 Bits**.

#### COM1 Parity

A parity bit can be sent along with regular data bits to detect data transmission errors. Select Even if the parity bit is set to 0, and the number of 1's in data bits is even. Select Odd if the parity bit is set to 0, and the number of 1's in data bits is odd. Select None if you do not want to send a parity bit with your data bits in transmission. Select Mark to add a mark as a parity bit to be sent along with the data bits. Select Space to add a Space as a parity bit to be sent with your data bits. The options are **None**, Even, Odd, Mark and Space.

#### COM1 Stop Bits

A stop bit indicates the end of a serial data packet. Select 1 Stop Bit for standard serial data communication. Select 2 Stop Bits if slower devices are used. The options are **1** and 2.

**COM1 Flow Control**

Use this feature to set the flow control for Console Redirection to prevent data loss caused by buffer overflow. Send a "Stop" signal to stop sending data when the receiving buffer is full. Send a "Start" signal to start sending data when the receiving buffer is empty. The options are **None** and Hardware RTS/CTS.

**COM1 VT-UTF8 Combo Key Support**

Select Enabled to enable VT-UTF8 Combination Key support for ANSI/VT100 terminals. The options are **Enabled** and Disabled.

**COM1 Recorder Mode**

Select Enabled to capture the data displayed on a terminal and send it as text messages to a remote server. The options are **Disabled** and Enabled.

**COM1 Resolution 100x31**

Select Enabled for extended-terminal resolution support. The options are Disabled and **Enabled**.

**COM1 Legacy OS Redirection Resolution**

Use this feature to select the number of rows and columns used in Console Redirection for legacy OS support. The options are 80x24 and **80x25**.

**COM1 Putty KeyPad**

This feature selects the settings for Function Keys and KeyPad used for Putty, which is a terminal emulator designed for the Windows OS. The options are **VT100**, LINUX, XTERMR6, SC0, ESCN, and VT400.

**COM1 Redirection After BIOS Post**

Use this feature to enable or disable legacy console redirection after BIOS POST. When set to Bootloader, legacy console redirection is disabled before booting the OS. When set to Always Enable, legacy console redirection remains enabled when booting the OS. The options are **Always Enable** and Bootloader.

**COM2 Console Redirection**

Select Enabled to use the SOL port for Console Redirection. The options are **Enabled** and **Disabled**.

*\*If the item above set to Enabled, the following items will become available for user's configuration:*

**►SOL/COM2 Console Redirection Settings**

Use this feature to specify how the host computer will exchange data with the client computer, which is the remote computer used by the user.

**COM2 Terminal Type**

Use this feature to select the target terminal emulation type for Console Redirection. Select VT100 to use the ASCII Character set. Select VT100+ to add color and function key support. Select ANSI to use the Extended ASCII Character Set. Select VT-UTF8 to use UTF8 encoding to map Unicode characters into one or more bytes. The options are ANSI, VT100, **VT100+**, and VT-UTF8.

**COM2 Bits Per second**

Use this feature to set the transmission speed for a serial port used in Console Redirection. Make sure that the same speed is used in the host computer and the client computer. A lower transmission speed may be required for long and busy lines. The options are 9600, 19200, 38400, 57600 and **115200** (bits per second).

**COM2 Data Bits**

Use this feature to set the data transmission size for Console Redirection. The options are 7 (Bits) and **8 (Bits)**.

**COM2 Parity**

A parity bit can be sent along with regular data bits to detect data transmission errors. Select Even if the parity bit is set to 0, and the number of 1's in data bits is even. Select Odd if the parity bit is set to 0, and the number of 1's in data bits is odd. Select None if you do not want to send a parity bit with your data bits in transmission. Select Mark to add a mark as a parity bit to be sent along with the data bits. Select Space to add a Space as a parity bit to be sent with your data bits. The options are **None**, Even, Odd, Mark and Space.

**COM2 Stop Bits**

A stop bit indicates the end of a serial data packet. Select 1 Stop Bit for standard serial data communication. Select 2 Stop Bits if slower devices are used. The options are **1** and 2.

**COM2 Flow Control**

Use this feature to set the flow control for Console Redirection to prevent data loss caused by buffer overflow. Send a "Stop" signal to stop sending data when the receiving buffer is full. Send a "Start" signal to start sending data when the receiving buffer is empty. The options are **None** and Hardware RTS/CTS.

**COM2 VT-UTF8 Combo Key Support**

Select Enabled to enable VT-UTF8 Combination Key support for ANSI/VT100 terminals. The options are **Enabled** and Disabled.

**COM2 Recorder Mode**

Select Enabled to capture the data displayed on a terminal and send it as text messages to a remote server. The options are **Disabled** and Enabled.

**COM2 Resolution 100x31**

Select Enabled for extended-terminal resolution support. The options are Disabled and **Enabled**.

**COM2 Legacy OS Redirection Resolution**

Use this feature to select the number of rows and columns used in Console Redirection for legacy OS support. The options are 80x24 and **80x25**.

**COM2 Putty KeyPad**

This feature selects Function Keys and KeyPad settings for Putty, which is a terminal emulator designed for the Windows OS. The options are **VT100**, LINUX, XTERMR6, SCO, ESCN, and VT400.

**COM2 Redirection After BIOS Post**

Use this feature to enable or disable legacy Console Redirection after BIOS POST. When set to Bootloader, legacy Console Redirection is disabled before booting the OS. When set to Always Enable, legacy Console Redirection remains enabled when booting the OS. The options are **Always Enable** and Bootloader.

**►EMS Console Redirection Settings**

This feature allows the user to specify how the host computer will exchange data with the client computer, which is the remote computer used by the user.

**Out-of-Band Management Port**

The feature selects a serial port in a client server to be used by the Microsoft Windows Emergency Management Services (EMS) to communicate with a remote host server. The options are **COM1**, and SOL/COM2.

**Terminal Type**

Use this feature to select the target terminal emulation type for Console Redirection. Select VT100 to use the ASCII character set. Select VT100+ to add color and function key support. Select ANSI to use the extended ASCII character set. Select VT-UTF8 to use UTF8 encoding to map Unicode characters into one or more bytes. The options are ANSI, VT100, VT100+, and **VT-UTF8**.

**Bits Per Second**

This item sets the transmission speed for a serial port used in Console Redirection. Make sure that the same speed is used in the host computer and the client computer. A lower

transmission speed may be required for long and busy lines. The options are 9600, 19200, 57600, and **115200** (bits per second).

**Flow Control**

Use this item to set the flow control for Console Redirection to prevent data loss caused by buffer overflow. Send a "Stop" signal to stop sending data when the receiving buffer is full. Send a "Start" signal to start sending data when the receiving buffer is empty. The options are **None**, Hardware RTS/CTS, and Software Xon/Xoff.

**Data Bits**

Use this feature to set the data transmission size for Console Redirection. The options are 7 (Bits) and **8 (Bits)**.

**Parity**

A parity bit can be sent along with regular data bits to detect data transmission errors. Select Even if the parity bit is set to 0, and the number of 1's in data bits is even. Select Odd if the parity bit is set to 0, and the number of 1's in data bits is odd. Select None if you do not want to send a parity bit with your data bits in transmission. Select Mark to add a mark as a parity bit to be sent along with the data bits. Select Space to add a Space as a parity bit to be sent with your data bits. The options are **None**, Even, Odd, Mark and Space.

**Stop Bits**

A stop bit indicates the end of a serial data packet. Select 1 Stop Bit for standard serial data communication. Select 2 Stop Bits if slower devices are used. The options are **1** and 2.

**►ACPI Settings****High Precision Event Timer**

Select Enabled to activate the High Performance Event Timer (HPET) that produces periodic interrupts at a much higher frequency than a Real-time Clock (RTC) does in synchronizing multimedia streams, providing smooth playback and reducing the dependency on other timestamp calculation devices, such as an x86 RDTSC Instruction embedded in the CPU. The High Performance Event Timer is used to replace the 8254 Programmable Interval Timer. The options are **Enabled** and Disabled.

**WHEA Support**

This feature Enables the Windows Hardware Error Architecture (WHEA) support for the Windows 2008 (or a later version) operating system. The options are **Enabled** and Disabled.



**When Log is Full**

Select Erase Immediately to immediately erase all errors in the SMBIOS event log when the event log is full. Select Do Nothing for the system to do nothing when the SMBIOS event log is full. The options are **Do Nothing** and Erase Immediately.

**SMBIOS Event Log Standard Settings****Log System Boot Event**

Select Enabled to log system boot events. The options are **Disabled** and Enabled.

**MECI (Multiple Event Count Increment)**

Enter the increment value for the multiple event counter. Enter a number between 1 to 255. The default setting is **1**.

**METW (Multiple Event Count Time Window)**

This item is used to determine how long (in minutes) the multiple event counter should wait before generating a new event log. Enter a number between 0 to 99. The default setting is **60**.

**Note:** Please reboot the system for the changes to take effect.

**►View SMBIOS Event Log**

This item allows the user to view the event in the SMBIOS event log. The following categories are displayed:

**Date/Time/Error Code/Severity**

**6.5 IPMI**

This submenu allows the user to configure Intelligent Platform Management Interface (IPMI) settings.



The following IPMI information will be displayed:

- IPMI Firmware Revision
- IPMI Status

**►System Event Log****Enabling/Disabling Options****SEL Components**

Select Enabled to enable all system event logging support at bootup. The options are **Enabled** and Disabled.

**Erasing Settings****Erase SEL**

Select Yes, On next reset to erase all system event logs upon next system reboot. Select Yes, On every reset to erase all system event logs upon each system reboot. Select No to keep all system event logs after each system reboot. The options are **No**, Yes, On next reset, and Yes, On every reset.

**When SEL is Full**

This feature allows the user to determine what the AMI BIOS should do when the system event log is full. Select Erase Immediately to erase all events in the log when the system event log is full. The options are **Do Nothing** and Erase Immediately.

**Note:** After making changes on a setting, be sure to reboot the system for the changes to take effect.

**►BMC Network Configuration**

The following items will be displayed:

- IPMI LAN Selection
- IPMI Network Link Status

**Update IPMI LAN Configuration**

Select Yes for the system BIOS to automatically reset the following IPMI settings upon next system boot. The options are Yes and **No**.

### Configuration Address Source (Available when the item above - Update IPMI LAN Configuration is set to Yes)

Use this item to select the IP address source for this computer. If Static is selected, you will need to know the IP address of this computer and enter it to the system manually in the field. If DHCP is selected, AMI BIOS will search for a DHCP (Dynamic Host Configuration Protocol) server attached to the network and request the next available IP address for this computer. The options are **DHCP** and Static.

### Station IP Address

This item displays the Station IP address for this computer. This should be in decimal and in dotted quad form (i.e., 192.168.10.253).

### Subnet Mask

This item displays the sub-network that this computer belongs to. The value of each three-digit number is separated by dots and it should not exceed 255.

### Station MAC Address

This item displays the Station MAC address for this computer. Mac addresses are 6 two-digit hexadecimal numbers.

### Router IP Address

This item displays the Router IP address for this computer. This should be in decimal and in dotted quad form (i.e., 172.31.0.1).

## 6.6 Security

This menu allows the user to configure the following security settings for the system.



### Password Check

Select Setup for the system to check for a password at Setup. Select Always for the system to check for a password at bootup or upon entering the BIOS Setup utility. The options are **Setup** and Always.

### Administrator Password

Press Enter to create a new, or change an existing Administrator password.

### ► Secure Boot Menu

This section displays the contents of the following secure boot features:

- System Mode
- Secure Boot
- Vendor Keys

### Secure Boot

Use this item to enable secure boot. The options are **Disabled** and Enabled.

### Secure Boot Mode

Use this item to select the secure boot mode. The options are Standard and **Custom**.

### CSM Support

Select Enabled to support the EFI Compatibility Support Module (CSM), which provides compatibility support for traditional legacy BIOS for system boot. The options are **Enabled** and Disabled.

## ►Key Management

This submenu allows the user to configure the following Key Management settings.

### Provision Factory Default Keys (Available when the system is in Setup Mode)

Select Enabled to install factory default secure-boot keys. The options are Enabled and Disabled.

### ►Enroll All Factory Default Keys

This feature allows the user to store security-related boot data in a file of the same named in the system root folder of your computer.

### ►Save All Secure Boot Variables

This feature allows the user to save the secure boot settings specified by the user.

**Secure Boot Variables: Size/Key#/Key Source**

### ►Platform Key (PK): Size/Key#/Key Source

### ►Key Exchange Keys: Size/Key#/Key Source

### ►Authorized Signatures: Size/Key#/Key Source

### ►Forbidden Signatures: Size/Key#/Key Source

### ►Authorized TimeStamps: Size/Key#/Key Source

## 6.7 Boot Settings

This submenu allows the user to configure Boot settings for this system:

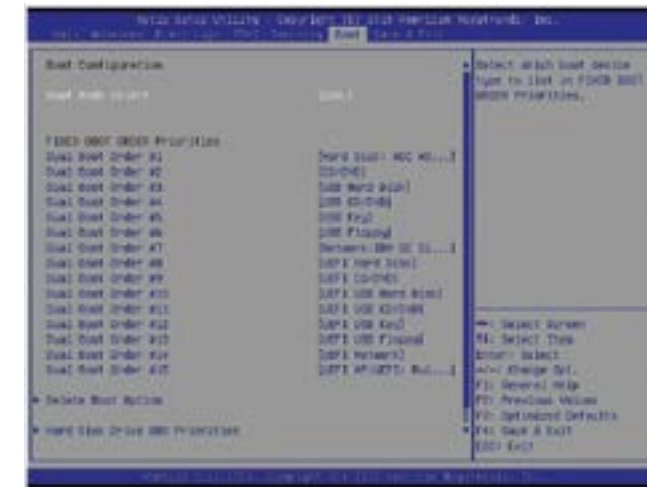

### Boot Configuration

#### Boot Mode Select

Use this item to select the type of device to be used for system boot. The options are Legacy, UEFI, and **Dual**.

#### Fixed Boot Order Priorities

This option prioritizes the order of bootable devices from which the system will boot. Press <Enter> on each entry from top to bottom to select devices.

- When the item above -"Boot Mode Select" is set to Dual (default), the following items will be displayed for configuration:

Boot Option #1 - Boot Option #15

- When the item above -"Boot Mode Select" is set to Legacy, the following items will be display for configuration:

Boot Option #1 - Boot Option #7

- When the item above -"Boot Mode Select" is set to UEFI, the following items will be display for configuration:

Boot Option #1 - Boot Option #8

**►Delete Boot Option**

Use this item to select a boot device to delete from the boot priority list.

**Delete Boot Option**

Select the target boot device to delete from the boot priority list.

**►Hard Disk Drive BBS Priorities**

- Boot Option #1
- Boot Option #2

**►Network Drive BBS Priorities**

- Boot Option #1

**►UEFI Application Boot Priorities**

- UEFI Boot Option #1

**6.8 Save & Exit**

Select the Exit tab from the BIOS setup utility screen to enter the Exit BIOS Setup screen.

**Discard Changes and Exit**

Select this option to quit the BIOS Setup without making any permanent changes to the system configuration, and reboot the computer. Select Discard Changes and Exit from the Exit menu and press <Enter>.

**Save Changes and Reset**

When you have completed the system configuration changes, select this option to leave the BIOS setup utility and reboot the computer, so the new system configuration parameters can take effect. Select Save Changes and Exit from the Exit menu and press <Enter>.

**Save Changes**

After completing the system configuration changes, select this option to save the changes you have made. This will not reset (reboot) the system.

**Discard Changes**

Select this option and press <Enter> to discard all the changes and return to the AMI BIOS utility Program.

**Default Options****Restore Optimized Defaults**

To set this feature, select Restore Optimized Defaults from the Save & Exit menu and press <Enter>. These are factory settings designed for maximum system performance, but not for maximum security.

### **Save As User Defaults**

To set this feature, select Save as User Defaults from the Exit menu and press <Enter>. This enables the user to save any changes to the BIOS setup for future use.

### **Restore User Defaults**

To set this feature, select Restore User Defaults from the Exit menu and press <Enter>. Use this feature to retrieve user-defined settings that were saved previously.

### **Boot Override**

Listed on this section are other boot options for the system (i.e., Built-in EFI shell). Select an option and press <Enter>. Your system will boot to the selected boot option.

# Appendix A

## BIOS Error Codes

### A-1 BIOS Error Beep (POST) Codes

During the POST (Power-On Self-Test) routines, which are performed each time the system is powered on, errors may occur.

**Non-fatal errors** are those which, in most cases, allow the system to continue the boot-up process. The error messages normally appear on the screen.

**Fatal errors** are those which will not allow the system to continue the boot-up procedure. If a fatal error occurs, you should consult with your system manufacturer for possible repairs.

These fatal errors are usually communicated through a series of audible beeps. The numbers on the fatal error list (on the following page) correspond to the number of beeps for the corresponding error. All errors listed, with the exception of Beep Code 8, are fatal errors.

BIOS Beep (POST) Codes		
Beep Code	Error Message	Description
1 beep	Refresh	Ready to boot
5 short, 1 long	Memory error	No memory detected in system
5 beeps	No con-in or con-out devices	Con-in includes USB or PS/2 keyboard, PCI or serial console redirection, and IPMI KVM or SOL. Con-out includes the video controller, PCI or serial console redirection, and IPMI SOL.
1 beep per device	Refresh	1 beep for each USB device detected

IPMI Error Codes		
Beep Code	Error Message	Description
1 continuous beep	System OH	System overheat

### A-2 Additional BIOS POST Codes

The AMI BIOS supplies additional checkpoint codes, which are documented online at <http://www.supermicro.com/support/manuals/> ("AMI BIOS POST Codes User's Guide").

When BIOS performs the Power On Self Test, it writes checkpoint codes to I/O port 0080h. If the computer cannot complete the boot process, a diagnostic card can be attached to the computer to read I/O port 0080h (Supermicro p/n AOC-LPC80-20).

For information on AMI updates, please refer to <http://www.ami.com/products/>.

## Appendix B

# Standardized Warning Statements for AC Systems

### B.1 About Standardized Warning Statements

The following statements are industry standard warnings, provided to warn the user of situations which have the potential for bodily injury. Should you have questions or experience difficulty, contact Supermicro's Technical Support department for assistance. Only certified technicians should attempt to install or configure components.

Read this appendix in its entirety before installing or configuring components in the Supermicro chassis.

These warnings may also be found on our website at [http://www.supermicro.com/about/policies/safety\\_information.cfm](http://www.supermicro.com/about/policies/safety_information.cfm).

#### Warning Definition



**Warning!** This warning symbol means danger. You are in a situation that could cause bodily injury. Before you work on any equipment, be aware of the hazards involved with electrical circuitry and be familiar with standard practices for preventing accidents.

#### 警告の定義

この警告サインは危険を意味します。

人身事故につながる可能性がありますので、いずれの機器でも動作させる前に、電気回路に含まれる危険性に注意して、標準的な事故防止策に精通して下さい。

此警告符号代表危險。

您正处于可能受到严重伤害的工作环境中。在您使用设备开始工作之前，必须充分意识到触电的危险，并熟练掌握防止事故发生的标准工作程序。请根据每项警告结尾的声明号码找到此设备的安全性警告说明的翻译文本。

此警告符號代表危險。

您正處於可能身體可能會受損傷的工作環境中。在您使用任何設備之前，請注意觸電的危險，並且要熟悉預防事故發生的標準工作程序。請依照每一注意事項後的號碼找到相關的翻譯說明內容。

#### Warnung

#### WICHTIGE SICHERHEITSHINWEISE

Dieses Warnsymbol bedeutet Gefahr. Sie befinden sich in einer Situation, die zu Verletzungen führen kann. Machen Sie sich vor der Arbeit mit Geräten mit den Gefahren elektrischer Schaltungen und den üblichen Verfahren zur Vorbeugung vor Unfällen vertraut. Suchen Sie mit der am Ende jeder Warnung angegebenen Anweisungsnummer nach der jeweiligen Übersetzung in den übersetzten Sicherheitshinweisen, die zusammen mit diesem Gerät ausgeliefert wurden.

BEWAHREN SIE DIESE HINWEISE GUT AUF.

#### INSTRUCCIONES IMPORTANTES DE SEGURIDAD

Este símbolo de aviso indica peligro. Existe riesgo para su integridad física. Antes de manipular cualquier equipo, considere los riesgos de la corriente eléctrica y familiarícese con los procedimientos estándar de prevención de accidentes. Al final de cada advertencia encontrará el número que le ayudará a encontrar el texto traducido en el apartado de traducciones que acompaña a este dispositivo.

GUARDE ESTAS INSTRUCCIONES.

#### IMPORTANTES INFORMATIONS DE SÉCURITÉ

Ce symbole d'avertissement indique un danger. Vous vous trouvez dans une situation pouvant entraîner des blessures ou des dommages corporels. Avant de travailler sur un équipement, soyez conscient des dangers liés aux circuits électriques et familiarisez-vous avec les procédures couramment utilisées pour éviter les accidents. Pour prendre connaissance des traductions des avertissements figurant dans les consignes de sécurité traduites qui accompagnent cet appareil, référez-vous au numéro de l'instruction situé à la fin de chaque avertissement.

CONSERVEZ CES INFORMATIONS.

#### תקנון הזהרות אזהרה

הזהרות הבאות הן אזהרות על פי תקני התעשייה, על מנת להזהיר את המשתמש מפני חבלה פיזית אפשרית. במידה ויש שאלות או היתקלות בבעיה כלשהי, יש ליצור קשר עם מחלקת תמיכה טכנית של סופרמיקרו. טכנאים מוסמכים בלבד רשאים להתקין או להגדיר את הרכיבים.

יש לקרוא את הנספח במלואו לפני התקנת או הגדרת הרכיבים במארזי סופרמיקרו.

تحذير! هذا الرمز يعني خطر انك في حالة يمكن أن تتسبب في اصابة جسدية .  
قبل أن تعمل على أي معدات، كن على علم بالمخاطر الناجمة عن الدوائر  
الكهربائية  
وكن على دراية بالممارسات الوقائية لمنع وقوع أي حوادث  
استخدم رقم البيان المنصوص في نهاية كل تحذير للعثور ترجمتها

안전을 위한 주의사항

경고!

이 경고 기호는 위험이 있음을 알려 줍니다. 작업자의 신체에 부상을 야기 할 수 있는  
상태에 있게 됩니다. 모든 장비에 대한 작업을 수행하기 전에 전기회로와 관련된  
위험요소들을 확인하시고 사전에 사고를 방지할 수 있도록 표준 작업절차를 준수해 주시기  
바랍니다.

해당 번역문을 찾기 위해 각 경고의 마지막 부분에 제공된 경고문 번호를 참조하십시오

#### BELANGRIJKE VEILIGHEIDSINSTRUCTIES

Dit waarschuwings symbool betekent gevaar. U verkeert in een situatie die lichamelijk letsel kan veroorzaken. Voordat u aan enige apparatuur gaat werken, dient u zich bewust te zijn van de bij een elektrische installatie betrokken risico's en dient u op de hoogte te zijn van de standaard procedures om ongelukken te voorkomen. Gebruik de nummers aan het eind van elke waarschuwing om deze te herleiden naar de desbetreffende locatie.

BEWAAR DEZE INSTRUCTIES

#### Installation Instructions



**Warning!** Read the installation instructions before connecting the system to the power source.

#### 設置手順書

システムを電源に接続する前に、設置手順書をお読み下さい。

警告

将此系统连接电源前，请先阅读安装说明。

警告

將系統與電源連接前，請先閱讀安裝說明。

Warnung

Vor dem Anschließen des Systems an die Stromquelle die Installationsanweisungen lesen.

¡Advertencia!

Lea las instrucciones de instalación antes de conectar el sistema a la red de alimentación.

Attention

Avant de brancher le système sur la source d'alimentation, consulter les directives d'installation.

יש לקרוא את הוראות התקנה לפני חיבור המערכת למקור מתח.

اقرأ إرشادات التركيب قبل توصيل النظام إلى مصدر للطاقة

시스템을 전원에 연결하기 전에 설치 안내를 읽어주십시오.

Waarschuwing

Raadpleeg de installatie-instructies voordat u het systeem op de voedingsbron aansluit.

#### Circuit Breaker



**Warning!** This product relies on the building's installation for short-circuit (overcurrent) protection. Ensure that the protective device is rated not greater than: 250 V, 20 A.

サーキット・ブレーカー

この製品は、短絡(過電流)保護装置がある建物での設置を前提としています。

保護装置の定格が250 V、20 Aを超えないことを確認下さい。

警告

此产品的短路(过载电流)保护由建筑物的供电系统提供，确保短路保护设备的额定电流不大于250V, 20A。

警告

此產品的短路(過載電流)保護由建築物的供電系統提供，確保短路保護設備的額定電流不大於250V, 20A。

**Warnung**

Dieses Produkt ist darauf angewiesen, dass im Gebäude ein Kurzschluss- bzw. Überstromschutz installiert ist. Stellen Sie sicher, dass der Nennwert der Schutzvorrichtung nicht mehr als: 250 V, 20 A beträgt.

**¡Advertencia!**

Este equipo utiliza el sistema de protección contra cortocircuitos (o sobrecorrientes) del edificio. Asegúrese de que el dispositivo de protección no sea superior a: 250 V, 20 A.

**Attention**

Pour ce qui est de la protection contre les courts-circuits (surtension), ce produit dépend de l'installation électrique du local. Vérifiez que le courant nominal du dispositif de protection n'est pas supérieur à :250 V, 20 A.

מוצר זה מסתמך על הגנה המותקנת במבנים למניעת קצר חשמלי. יש לוודא כי המכשיר המגן מפני הקצר החשמלי הוא לא יותר מ-20A, 60VDC.

هذا المنتج يعتمد على معدات الحماية من الدوائر القصيرة التي تم تثبيتها في المبني  
تأكد من أن تقييم الجهاز الوفاي ليس أكثر من: 20A, 250VDC

**경고!**

이 제품은 전원의 단락(과전류)방지에 대해서 전적으로 건물의 관련 설비에 의존합니다. 보호장치의 정격이 반드시 250V(볼트), 20A(암페어)를 초과하지 않도록 해야 합니다.

**Waarschuwing**

Dit product is afhankelijk van de kortsluitbeveiliging (overspanning) van uw elektrische installatie. Controleer of het beveiligde apparaat niet groter gedimensioneerd is dan 250V, 20A.

**Power Disconnection Warning**

**Warning!** The system must be disconnected from all sources of power and the power cord removed from the power supply module(s) before accessing the chassis interior to install or remove system components.

**電源切斷の警告**

システムコンポーネントの取り付けまたは取り外しのために、シャーシ内部にアクセスするには、システムの電源はすべてのソースから切斷され、電源コードは電源モジュールから取り外す必要があります。

**警告**

在你打开机箱并安装或移除内部器件前,必须将系统完全断电,并移除电源线。

**警告**

在您打開機殼安裝或移除內部元件前,必須將系統完全斷電,並移除電源線。

**Warnung**

Das System muss von allen Quellen der Energie und vom Netzanschlusskabel getrennt sein, das von den Spg.Versorgungsteilmodulen entfernt wird, bevor es auf den Chassisinnenraum zurückgreift, um Systemsbestandteile anzubringen oder zu entfernen.

**¡Advertencia!**

El sistema debe ser disconnected de todas las fuentes de energía y del cable eléctrico quitado de los módulos de fuente de alimentación antes de tener acceso el interior del chasis para instalar o para quitar componentes de sistema.

**Attention**

Le système doit être débranché de toutes les sources de puissance ainsi que de son cordon d'alimentation secteur avant d'accéder à l'intérieur du chassis pour installer ou enlever des composants de système.

**אזהרה מפני ניתוק חשמלי****אזהרה!**

יש לנתק את המערכת מכל מקורות החשמל ויש להסיר את כבל החשמלי מהספק לפני גישה לחלק הפנימי של המארז לצורך התקנת או הסרת רכיבים.

يجب فصل النظام من جميع مصادر الطاقة وإزالة سلك الكهرباء من وحدة امداد  
الطاقة قبل  
الوصول إلى المناطق الداخلية للهيكل لتثبيت أو إزالة مكونات الجهاز

경고!

시스템에 부품들을 장착하거나 제거하기 위해서는 새시 내부에 접근하기 전에 반드시 전원 공급장치로부터 연결되어있는 모든 전원과 전기코드를 분리해주어야 합니다.

Waarschuwing

Voordat u toegang neemt tot het binnenwerk van de behuizing voor het installeren of verwijderen van systeem onderdelen, dient u alle spanningsbronnen en alle stroomkabels aangesloten op de voeding(en) van de behuizing te verwijderen

## Equipment Installation



**Warning!** Only trained and qualified personnel should be allowed to install, replace, or service this equipment.

機器の設置

トレーニングを受け認定された人だけがこの装置の設置、交換、またはサービスを許可されていません。

警告

只有经过培训且具有资格的人员才能进行此设备的安装、更换和维修。

警告

只有經過受訓且具資格人員才可安裝、更換與維修此設備。

Warnung

Das Installieren, Ersetzen oder Bedienen dieser Ausrüstung sollte nur geschultem, qualifiziertem Personal gestattet werden.

¡Advertencia!

Solamente el personal calificado debe instalar, reemplazar o utilizar este equipo.

Attention

Il est vivement recommandé de confier l'installation, le remplacement et la maintenance de ces équipements à des personnels qualifiés et expérimentés.

אזהרה!

צוות מוסמך בלבד רשאי להתקין, להחליף את הציוד או לתת שירות עבור הציוד.

يجب أن يسمح فقط للموظفين المؤهلين والمدربين لتثبيت واستبدال أو خدمة هذا الجهاز

경고!

훈련을 받고 공인된 기술자만이 이 장비의 설치, 교체 또는 서비스를 수행할 수 있습니다.

Waarschuwing

Deze apparatuur mag alleen worden geïnstalleerd, vervangen of hersteld door geschoold en gekwalificeerd personeel.

## Restricted Area



**Warning!** This unit is intended for installation in restricted access areas. A restricted access area can be accessed only through the use of a special tool, lock and key, or other means of security. (This warning does not apply to workstations).

アクセス制限区域

このユニットは、アクセス制限区域に設置されることを想定しています。

アクセス制限区域は、特別なツール、鍵と錠前、その他のセキュリティの手段を用いてのみ出入りが可能です。

警告

此部件应安装在限制进出的场所，限制进出的场所指只能通过使用特殊工具、锁和钥匙或其它安全手段进出的场所。

警告

此裝置僅限安裝於進出管制區域，進出管制區域係指僅能以特殊工具、鎖頭及鑰匙或其他安全方式才能進入的區域。

**Warnung**

Diese Einheit ist zur Installation in Bereichen mit beschränktem Zutritt vorgesehen. Der Zutritt zu derartigen Bereichen ist nur mit einem Spezialwerkzeug, Schloss und Schlüssel oder einer sonstigen Sicherheitsvorkehrung möglich.

**¡Advertencia!**

Esta unidad ha sido diseñada para instalación en áreas de acceso restringido. Sólo puede obtenerse acceso a una de estas áreas mediante la utilización de una herramienta especial, cerradura con llave u otro medio de seguridad.

**Attention**

Cet appareil doit être installé dans des zones d'accès réservés. L'accès à une zone d'accès réservé n'est possible qu'en utilisant un outil spécial, un mécanisme de verrouillage et une clé, ou tout autre moyen de sécurité.

**אזור עם גישה מוגבלת****אזהרה!**

יש להתקין את היחידה באזורים שיש בהם הגבלת גישה. הגישה ניתנת בעזרת כלי אבטחה בלבד (מפתח, מנעול וכד').

تم تخصيص هذه الوحدة لت تركيبها في مناطق محظورة .  
يمكن الوصول إلى منطقة محظورة فقط من خلال استخدام أداة خاصة،  
قفل ومفتاح أو أي وسيلة أخرى للأمان

**경고!**

이 장치는 접근이 제한된 구역에 설치하도록 되어 있습니다. 특수도구, 잠금 장치 및 키, 또는 기타 보안 수단을 통해서만 접근 제한 구역에 들어갈 수 있습니다.

**Waarschuwing**

Dit apparaat is bedoeld voor installatie in gebieden met een beperkte toegang. Toegang tot dergelijke gebieden kunnen alleen verkregen worden door gebruik te maken van speciaal gereedschap, slot en sleutel of andere veiligheidsmaatregelen.

**Battery Handling**

**Warning!** There is the danger of explosion if the battery is replaced incorrectly. Replace the battery only with the same or equivalent type recommended by the manufacturer. Dispose of used batteries according to the manufacturer's instructions

**電池の取り扱い**

電池交換が正しく行われなかった場合、破裂の危険性があります。交換する電池はメーカーが推奨する型、または同等のものを使用下さい。使用済電池は製造元の指示に従って処分して下さい。

**警告**

電池更換不當會有爆炸危險。請只使用同類電池或製造商推薦的功能相當的電池更換原有電池。請按製造商的說明處理廢舊電池。

**警告**

電池更換不當會有爆炸危險。請使用製造商建議之相同或功能相當的電池更換原有電池。請按照製造商的說明指示處理廢棄舊電池。

**Warnung**

Bei Einsetzen einer falschen Batterie besteht Explosionsgefahr. Ersetzen Sie die Batterie nur durch den gleichen oder vom Hersteller empfohlenen Batterietyp. Entsorgen Sie die benutzten Batterien nach den Anweisungen des Herstellers.

**Attention**

Danger d'explosion si la pile n'est pas remplacée correctement. Ne la remplacer que par une pile de type semblable ou équivalent, recommandée par le fabricant. Jeter les piles usagées conformément aux instructions du fabricant.

**¡Advertencia!**

Existe peligro de explosión si la batería se reemplaza de manera incorrecta. Reemplazar la batería exclusivamente con el mismo tipo o el equivalente recomendado por el fabricante. Desechar las baterías gastadas según las instrucciones del fabricante.

**אזהרה!**

קיימת סכנת פיצוץ של הסוללה במידה והוחלפה בדרך לא תקינה. יש להחליף את הסוללה בסוג התואם מחברת יצרן מומלצת.

סילוק הסוללות המשומשות יש לבצע לפי הוראות היצרן.

هناك خطر من انفجار في حالة استبدال البطارية بطريقة غير صحيحة فعليك  
استبدال البطارية  
فقط بنفس النوع أو ما يعادلها كما أوصت به الشركة المصنعة  
تخلص من البطاريات المستعملة وفقا لتعليمات الشركة الصانعة

경고!

배터리가 올바르게 교체되지 않으면 폭발의 위험이 있습니다. 기존 배터리와 동일하거나 제조사에서 권장하는 동등한 종류의 배터리로만 교체해야 합니다. 제조사의 안내에 따라 사용된 배터리를 처리하여 주십시오.

Waarschuwing

Er is ontplofingsgevaar indien de batterij verkeerd vervangen wordt. Vervang de batterij slechts met hetzelfde of een equivalent type die door de fabrikant aanbevolen wordt. Gebruikte batterijen dienen overeenkomstig fabrieksvoorschriften afgevoerd te worden.

## Redundant Power Supplies



**Warning!** This unit might have more than one power supply connection. All connections must be removed to de-energize the unit.

冗長電源装置

このユニットは複数の電源装置が接続されている場合があります。

ユニットの電源を切るためには、すべての接続を取り外さなければなりません。

警告

此部件连接的电源可能不止一个，必须将所有电源断开才能停止给该部件供电。

警告

此装置连接的电源可能不只一个，必须切断所有电源才能停止对该装置的供电。

Warnung

Dieses Gerät kann mehr als eine Stromzufuhr haben. Um sicherzustellen, dass der Einheit kein Strom zugeführt wird, müssen alle Verbindungen entfernt werden.

¡Advertencia!

Puede que esta unidad tenga más de una conexión para fuentes de alimentación. Para cortar por completo el suministro de energía, deben desconectarse todas las conexiones.

Attention

Cette unité peut avoir plus d'une connexion d'alimentation. Pour supprimer toute tension et tout courant électrique de l'unité, toutes les connexions d'alimentation doivent être débranchées.

אם קיים יותר מספק אחד

אזהרה!

ליחידה יש יותר מחיבור אחד של ספק. יש להסיר את כל החיבורים על מנת לרוקן את היחידה.

قد يكون لهذا الجهاز عدة اتصالات بوحدات امداد الطاقة.  
يجب إزالة كافة الاتصالات لعزل الوحدة عن الكهرباء

경고!

이 장치에는 한 개 이상의 전원 공급 단자가 연결되어 있을 수 있습니다. 이 장치에 전원을 차단하기 위해서는 모든 연결 단자를 제거해야만 합니다.

Waarschuwing

Deze eenheid kan meer dan één stroomtoevoeraansluiting bevatten. Alle aansluitingen dienen verwijderd te worden om het apparaat stroomloos te maken.

## Backplane Voltage



**Warning!** Hazardous voltage or energy is present on the backplane when the system is operating. Use caution when servicing.

バックプレーンの電圧

システムの稼働中は危険な電圧または電力が、バックプレーン上にかかっています。

修理する際には注意ください。

警告

当系统正在进行时，背板上有很危险的电压或能量，进行维修时务必小心。

警告

當系統正在進行時，背板上有危險的電壓或能量，進行維修時務必小心。

Warnung

Wenn das System in Betrieb ist, treten auf der Rückwandplatine gefährliche Spannungen oder Energien auf. Vorsicht bei der Wartung.

¡Advertencia!

Cuando el sistema está en funcionamiento, el voltaje del plano trasero es peligroso. Tenga cuidado cuando lo revise.

Attention

Lorsque le système est en fonctionnement, des tensions électriques circulent sur le fond de panier. Prendre des précautions lors de la maintenance.

**מתח בפנל האחורי**

**אזהרה!**

קיימת סכנת מתח בפנל האחורי בזמן תפעול המערכת. יש להיזהר במהלך העבודה.

هناك خطر من التيار الكهربائي أو الطاقة الموجودة على اللوحة عندما يكون النظام يعمل كن حذرا عند خدمة هذا الجهاز

경고!

시스템이 동작 중일 때 후면판 (Backplane)에는 위험한 전압이나 에너지가 발생 합니다. 서비스 작업 시 주의하십시오.

Waarschuwing

Een gevaarlijke spanning of energie is aanwezig op de backplane wanneer het systeem in gebruik is. Voorzichtigheid is geboden tijdens het onderhoud.

## Comply with Local and National Electrical Codes



**Warning!** Installation of the equipment must comply with local and national electrical codes.

地方および国の電気規格に準拠

機器の取り付けはその地方および国の電気規格に準拠する必要があります。

警告

设备安装必须符合本地与本国电气法规。

警告

設備安裝必須符合本地與本國電氣法規。

Warnung

Die Installation der Geräte muss den Sicherheitsstandards entsprechen.

¡Advertencia!

La instalacion del equipo debe cumplir con las normas de electricidad locales y nacionales.

Attention

L'équipement doit être installé conformément aux normes électriques nationales et locales.

## תיאום חוקי החשמל הארצי

אזהרה!  
התקנת הציוד חייבת להיות תואמת לחוקי החשמל המקומיים והארציים.

تركيب المعدات الكهربائية يجب أن يمتثل للقوانين المحلية والوطنية المتعلقة بالكهرباء

경고!

현 지역 및 국가의 전기 규정에 따라 장비를 설치해야 합니다.

### Waarschuwing

Bij installatie van de apparatuur moet worden voldaan aan de lokale en nationale elektriciteitsvoorschriften.

## Product Disposal



**Warning!** Ultimate disposal of this product should be handled according to all national laws and regulations.

### 製品の廃棄

この製品を廃棄処分する場合、国の関係する全ての法律・条例に従い処理する必要があります。

警告

本产品的废弃处理应根据所有国家的法律和规章进行。

警告

本產品的廢棄處理應根據所有國家的法律和規章進行。

### Warnung

Die Entsorgung dieses Produkts sollte gemäß allen Bestimmungen und Gesetzen des Landes erfolgen.

¡Advertencia!

Al deshacerse por completo de este producto debe seguir todas las leyes y reglamentos nacionales.

### Attention

La mise au rebut ou le recyclage de ce produit sont généralement soumis à des lois et/ou directives de respect de l'environnement. Renseignez-vous auprès de l'organisme compétent.

## סילוק המוצר

אזהרה!  
סילוק סופי של מוצר זה חייב להיות בהתאם להנחיות וחוקי המדינה.

عند التخلص النهائي من هذا المنتج ينبغي التعامل معه وفقا لجميع القوانين واللوائح الوطنية

경고!

이 제품은 해당 국가의 관련 법규 및 규정에 따라 폐기되어야 합니다.

### Waarschuwing

De uiteindelijke verwijdering van dit product dient te geschieden in overeenstemming met alle nationale wetten en reglementen.

## Hot Swap Fan Warning



**Warning!** The fans might still be turning when you remove the fan assembly from the chassis. Keep fingers, screwdrivers, and other objects away from the openings in the fan assembly's housing.

### ファン・ホットスワップの警告

シャーシから冷却ファン装置を取り外した際、ファンがまだ回転している可能性があります。ファンの開口部に、指、ドライバー、およびその他のものを近づけないで下さい。

警告

当您从机架移除风扇装置，风扇可能仍在转动。小心不要将手指、螺丝起子和其他物品太靠近风扇

警告

當您從機架移除風扇裝置，風扇可能仍在轉動。小心不要將手指、螺絲起子和其他物品太靠近風扇。

**Warnung**

Die Lüfter drehen sich u. U. noch, wenn die Lüfterbaugruppe aus dem Chassis genommen wird. Halten Sie Finger, Schraubendreher und andere Gegenstände von den Öffnungen des Lüftergehäuses entfernt.

**¡Advertencia!**

Los ventiladores podran dar vuelta cuando usted quite el montaje del ventilador del chasis. Mantenga los dedos, los destornilladores y todos los objetos lejos de las aberturas del ventilador

**Attention**

Il est possible que les ventilateurs soient toujours en rotation lorsque vous retirerez le bloc ventilateur du châssis. Prenez garde à ce que doigts, tournevis et autres objets soient éloignés du logement du bloc ventilateur.

**אזהרה!**

כאשר מסירים את חלקי המאוורר מהמארז, יתכן והמאווררים עדיין עובדים. יש להרחיק למרחק בטוח את האצבעות וכלי עבודה שונים מהפתחים בתוך המאוורר

من الممكن أن المراوح لا تزال تدور عند إزالة كتلة المروحة من الهيكل يجب إبقاء الأصابع ومفكات البراغي وغيرها من الأشياء بعيدا عن الفتحات في كتلة المروحة.

**경고!**

새시로부터 팬 조립품을 제거할 때 팬은 여전히 회전하고 있을 수 있습니다. 팬 조립품 외관의 열려있는 부분들로부터 손가락 및 스크류드라이버, 다른 물체들이 가까이 하지 않도록 배치해 주십시오.

**Waarschuwing**

Het is mogelijk dat de ventilator nog draait tijdens het verwijderen van het ventilatorsamenstel uit het chassis. Houd uw vingers, schroevendraaiers en eventuele andere voorwerpen uit de buurt van de openingen in de ventilatorbehuizing.

**Power Cable and AC Adapter**

**Warning!** When installing the product, use the provided or designated connection cables, power cables and AC adaptors. Using any other cables and adaptors could cause a malfunction or a fire. Electrical Appliance and Material Safety Law prohibits the use of UL or CSA -certified cables (that have UL/CSA shown on the code) for any other electrical devices than products designated by Supermicro only.

**電源コードとACアダプター**

製品を設置する場合、提供または指定された接続ケーブル、電源コードとACアダプターを使用下さい。他のケーブルやアダプタを使用すると故障や火災の原因になることがあります。電気用品安全法は、ULまたはCSA認定のケーブル(UL/CSEマークがコードに表記)を Supermicroが指定する製品以外に使用することを禁止しています。

**警告**

安装此产品时,请使用本身提供的或指定的连接线,电源线和电源适配器.使用其它线材或适配器可能会引起故障或火灾。除了Supermicro所指定的产品,电气用品和材料安全法律规定禁止使用未经UL或CSA认证的线材。(线材上会显示UL/CSA符号)。

**警告**

安裝此產品時,請使用本身提供的或指定的連接線,電源線和電源適配器.使用其它線材或適配器可能會引起故障或火災。除了Supermicro所指定的產品,電氣用品和材料安全法律規定禁止使用未經UL或CSA認證的線材。(線材上會顯示UL/CSA符號)。

**Warnung**

Bei der Installation des Produkts, die zur Verfügung gestellten oder benannt Anschlusskabel, Stromkabel und Netzteile. Verwendung anderer Kabel und Adapter kann zu einer Fehlfunktion oder ein Brand entstehen. Elektrische Geräte und Material Safety Law verbietet die Verwendung von UL-oder CSA-zertifizierte Kabel, UL oder CSA auf der Code für alle anderen elektrischen Geräte als Produkte von Supermicro nur bezeichnet gezeigt haben.

**¡Advertencia!**

Al instalar el producto, utilice los cables de conexión previstos o designados, los cables y adaptadores de CA. La utilización de otros cables y adaptadores podría ocasionar un mal funcionamiento o un incendio. Aparatos Eléctricos y la Ley de Seguridad del Material prohíbe el uso de UL o CSA cables certificados que tienen UL o CSA se muestra en el código de otros dispositivos eléctricos que los productos designados por Supermicro solamente.

## Attention

Lors de l'installation du produit, utilisez les bables de connection fournis ou désigné. L'utilisation d'autres cables et adaptateurs peut provoquer un dysfonctionnement ou un incendie. Appareils électroménagers et de loi sur la sécurité Matériel interdit l'utilisation de UL ou CSA câbles certifiés qui ont UL ou CSA indiqué sur le code pour tous les autres appareils électriques que les produits désignés par Supermicro seulement.

## חשמליים ומתאמי AC

אזהרה!

כאשר מתקינים את המוצר, יש להשתמש בכבלים, ספקים ומתאמים AC אשר נועדו וסופקו לשם כך. שימוש בכל כבל או מתאם אחר יכול לגרום לתקלה או קצר חשמלי. על פי חוקי שימוש במכשירי חשמל וחוקי בטיחות, קיים איסור להשתמש בכבלים המוסמכים ב- UL או ב- CSA (כשאר מופיע עליהם קוד של UL/CSA) עבור כל מוצר חשמלי אחר שלא צויין על ידי סופרמיקרו בלבד.

عند تركيب الجهاز يجب استخدام كابلات التوصيل، والكابلات الكهربائية ومحولات التيار المتردد التي . أن استخدام أي كابلات ومحولات أخرى يتسبب في حدوث عطل أو حريق. تم توفيرها لك مع المنتج الأجهزة الكهربائية ومواد قانون السلامة يحظر استخدام الكابلات CSA أو UL معتمدة من قبل لأي أجهزة كهربائية أخرى غير المنتجات المعينة من قبل Supermicro (التي تحمل علامة UL/CSA)

## 경고!

제품을 설치할 때에는 제공되거나 지정된 연결케이블과 전원케이블, AC어댑터를 사용해야 합니다. 그 밖의 다른 케이블들이나 어댑터들은 고장 또는 화재의 원인이 될 수 있습니다. 전기용품안전법 (Electrical Appliance and Material Safety Law)은 슈퍼마이크로에서 지정한 제품들 외에는 그 밖의 다른 전기 장치들을 위한 UL 또는 CSA에서 인증한 케이블(전선 위에 UL/CSA가 표시)들의 사용을 금지합니다.

## Waarschuwing

Bij het installeren van het product, gebruik de meegeleverde of aangewezen kabels, stroomkabels en adapters. Het gebruik van andere kabels en adapters kan leiden tot een storing of een brand. Elektrisch apparaat en veiligheidsinformatiebladen wet verbiedt het gebruik van UL of CSA gecertificeerde kabels die UL of CSA die op de code voor andere elektrische apparaten dan de producten die door Supermicro alleen.

# Appendix C

## System Specifications

### Processors

Single E3-1200 v5 and 6th Gen Core i3, Pentium and Celeron processors in an LGA 1151 (H4) type socket

**Note:** Please refer to the motherboard specifications pages on our website for updates to supported processors.

### Chipset

Intel C236 chipset

### BIOS

128 Mb AMI® Flash ROM

### Memory

Four 240-pin DIMM slots that can support up to 64 GB of 72-bit DDR4 unbuffered ECC 2133/1866/1600/1333MHz SDRAM

**Note:** See the memory section in Chapter 5 for details and our website for updates to supported memory.

### SATA Controller

On-chip (C236) controller

### Drive Bays

Four 3.5" hot-swap drive bays to house four SATA drives

### PCI Expansion Slots

One PCI Express 3.0 x4 in x8 slot (PCH Slot 4)

One PCI Express 3.0 x8 (CPU Slot 5)

One PCI Express 3.0 x8 in x16 slot (CPU Slot 6)

One M.2 Mini PCI Express 3.0 x2 connector

### Motherboard

X11SSH-LN4F; Micro ATX form factor (9.6 x 9.6 in. / 244 x 244 mm.)

### Chassis

SC813MFTQC-350CB; 1U Rackmount, 17.2 x 1.7 x 20 in. / 437 x 43 x 508 mm. (W x H x D)

### System Cooling

Four 4-cm PWM fans

### Power Supply

Model: PWS-350-1H

AC Input Voltages: 100-240 VAC

Rated Input Current: 4.2A (100V) to 1.8A (240V)

Rated Input Frequency: 50-60 Hz

Rated Output Power: 350W

Rated Output Voltages: +5V (18A), +3.3V (15A), +12V (29A), +5Vsb (3A), -12V (0.5A)

### Operating Environment

Operating Temperature: 10° to 35° C (50° to 95° F)

Non-operating Temperature: -40° to 60° C (-40° to 140° F)

Operating Relative Humidity: 8% to 90% (non-condensing)

Non-operating Relative Humidity: 5% to 95% (non-condensing)

### Regulatory Compliance

Electromagnetic Emissions: FCC Class A, EN 55022 Class A, EN 61000-3-2/3-3, CISPR 22 Class A

Electromagnetic Immunity: EN 55024/CISPR 24, (EN 61000-4-2, EN 61000-4-3, EN 61000-4-4, EN 61000-4-5, EN 61000-4-6, EN 61000-4-8, EN 61000-4-11)

Safety: CSA/EN/IEC/UL 60950-1 Compliant, UL or CSA Listed (USA and Canada), CE Marking (Europe)

### Perchlorate Warning

California Best Management Practices Regulations for Perchlorate Materials: This Perchlorate warning applies only to products containing CR (Manganese Dioxide) Lithium coin cells. "Perchlorate Material-special handling may apply. See [www.dtsc.ca.gov/hazardouswaste/perchlorate](http://www.dtsc.ca.gov/hazardouswaste/perchlorate)"