

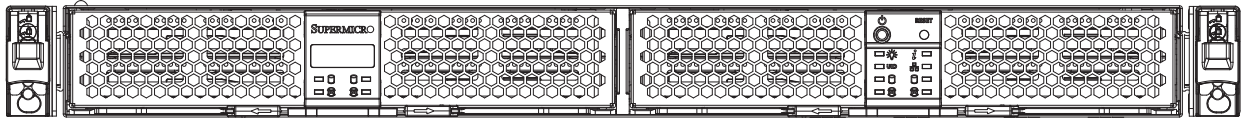

# SuperStorage SSG-136R-N32JBF



## USER'S MANUAL

Revision 1.2a

The information in this User's Manual has been carefully reviewed and is believed to be accurate. The vendor assumes no responsibility for any inaccuracies that may be contained in this document, and makes no commitment to update or to keep current the information in this manual, or to notify any person or organization of the updates. Please Note: For the most up-to-date version of this manual, please see our website at [www.supermicro.com](http://www.supermicro.com).

Super Micro Computer, Inc. ("Supermicro") reserves the right to make changes to the product described in this manual at any time and without notice. This product, including software and documentation, is the property of Supermicro and/or its licensors, and is supplied only under a license. Any use or reproduction of this product is not allowed, except as expressly permitted by the terms of said license.

IN NO EVENT WILL Super Micro Computer, Inc. BE LIABLE FOR DIRECT, INDIRECT, SPECIAL, INCIDENTAL, SPECULATIVE OR CONSEQUENTIAL DAMAGES ARISING FROM THE USE OR INABILITY TO USE THIS PRODUCT OR DOCUMENTATION, EVEN IF ADVISED OF THE POSSIBILITY OF SUCH DAMAGES. IN PARTICULAR, SUPER MICRO COMPUTER, INC. SHALL NOT HAVE LIABILITY FOR ANY HARDWARE, SOFTWARE, OR DATA STORED OR USED WITH THE PRODUCT, INCLUDING THE COSTS OF REPAIRING, REPLACING, INTEGRATING, INSTALLING OR RECOVERING SUCH HARDWARE, SOFTWARE, OR DATA.

Any disputes arising between manufacturer and customer shall be governed by the laws of Santa Clara County in the State of California, USA. The State of California, County of Santa Clara shall be the exclusive venue for the resolution of any such disputes. Supermicro's total liability for all claims will not exceed the price paid for the hardware product.

FCC Statement: This equipment has been tested and found to comply with the limits for a Class A or Class B digital device pursuant to Part 15 of the FCC Rules. These limits are designed to provide reasonable protection against harmful interference when the equipment is operated in industrial environment for Class A device or in residential environment for Class B device. This equipment generates, uses, and can radiate radio frequency energy and, if not installed and used in accordance with the manufacturer's instruction manual, may cause harmful interference with radio communications. Operation of this equipment in a residential area is likely to cause harmful interference, in which case you will be required to correct the interference at your own expense.

California Best Management Practices Regulations for Perchlorate Materials: This Perchlorate warning applies only to products containing CR (Manganese Dioxide) Lithium coin cells. "Perchlorate Material-special handling may apply. See [www.dtsc.ca.gov/hazardouswaste/perchlorate](http://www.dtsc.ca.gov/hazardouswaste/perchlorate)".



WARNING: This product can expose you to chemicals including lead, known to the State of California to cause cancer and birth defects or other reproductive harm. For more information, go to [www.P65Warnings.ca.gov](http://www.P65Warnings.ca.gov).

The products sold by Supermicro are not intended for and will not be used in life support systems, medical equipment, nuclear facilities or systems, aircraft, aircraft devices, aircraft/emergency communication devices or other critical systems whose failure to perform be reasonably expected to result in significant injury or loss of life or catastrophic property damage. Accordingly, Supermicro disclaims any and all liability, and should buyer use or sell such products for use in such ultra-hazardous applications, it does so entirely at its own risk. Furthermore, buyer agrees to fully indemnify, defend and hold Supermicro harmless for and against any and all claims, demands, actions, litigation, and proceedings of any kind arising out of or related to such ultra-hazardous use or sale.

Manual Revision 1.2a

Release Date: June 02, 2022

Unless you request and receive written permission from Super Micro Computer, Inc., you may not copy any part of this document. Information in this document is subject to change without notice. Other products and companies referred to herein are trademarks or registered trademarks of their respective companies or mark holders.

Copyright © 2022 by Super Micro Computer, Inc.  
All rights reserved.

**Printed in the United States of America**

# Preface

## About this Manual

This manual is written for professional system integrators and PC technicians. It provides information for the installation and use of the SuperStorage SSG-136R-N32JBF. Installation and maintenance should be performed by experienced technicians only.

Please refer to the SSG-136R-N32JBF system specifications page on our website for updates on supported memory, processors and operating systems (<http://www.supermicro.com>).

## Notes

For your system to work properly, please follow the links below to download all necessary drivers/utilities and the user's manual for your server.

- Supermicro product manuals: <http://www.supermicro.com/support/manuals/>
- Product drivers and utilities: <https://www.supermicro.com/wdl/driver>
- Product safety info: [http://www.supermicro.com/about/policies/safety\\_information.cfm](http://www.supermicro.com/about/policies/safety_information.cfm)

If you have any questions, please contact our support team at:  
[support@supermicro.com](mailto:support@supermicro.com)

This manual may be periodically updated without notice. Please check the Supermicro website for possible updates to the manual revision level.

## Secure Data Deletion

A secure data deletion tool designed to fully erase all data from storage devices can be found on our website: [https://www.supermicro.com/about/policies/disclaimer.cfm?url=/wdl/utility/Lot9\\_Secure\\_Data\\_Deletion\\_Utility/](https://www.supermicro.com/about/policies/disclaimer.cfm?url=/wdl/utility/Lot9_Secure_Data_Deletion_Utility/)

## Warnings

Special attention should be given to the following symbols used in this manual.



**Warning!** Indicates important information given to prevent equipment/property damage or personal injury.



**Warning!** Indicates high voltage may be encountered when performing a procedure.

# Contents

## **Chapter 1 Introduction**

1.1 Overview.....	7
1.2 Unpacking the System .....	7
1.3 System Features .....	8
1.4 System Chassis Features .....	9
Control Panels.....	9
Front Features.....	10
Rear Features .....	11
Sled Features.....	12
1.5 Controller Board Layout .....	13
Quick Reference Table.....	13
1.6 Ports .....	14
Unit Identifier Button.....	14
External PCIe Ports.....	14

## **Chapter 2 System Installation**

2.1 Overview.....	15
2.2 Preparing for Setup.....	15
Choosing a Setup Location.....	15
Rack Precautions .....	15
System Precautions .....	16
Rack Mounting Considerations .....	16
Ambient Operating Temperature.....	16
Airflow .....	16
Mechanical Loading.....	16
Circuit Overloading .....	17
Reliable Ground.....	17
2.3 Installing the System into a Rack.....	18
Identifying the Sections of the Rack Rails .....	18
Releasing the Inner Rails.....	19
Installing The Inner Rails on the Chassis.....	20
Installing the Outer Rails on the Rack.....	21
Installing the Chassis onto the Rack .....	23



2.4 Powering On the System .....24  
2.5 Assigning Drives to Host Servers .....24

**Chapter 3 Maintenance and Component Installation**

3.1 Removing Power .....25  
3.2 Accessing the System .....25  
3.3 Chassis Components .....27  
    Drives .....27  
    System Cooling .....30  
    Power Supply .....31  
        Power Supply Failure .....31  
    PCIe Cables .....32  
    PCIe Expansion Cards .....35

**Appendix A Standardized Warning Statements for AC Systems**

**Appendix B System Specifications**

**Appendix C Drive Assignment**

**Appendix D Firmware Updates**

## Contacting Supermicro

### Headquarters

Address: Super Micro Computer, Inc.  
980 Rock Ave.  
San Jose, CA 95131 U.S.A.

Tel: +1 (408) 503-8000

Fax: +1 (408) 503-8008

Email: [marketing@supermicro.com](mailto:marketing@supermicro.com) (General Information)  
[support@supermicro.com](mailto:support@supermicro.com) (Technical Support)

Website: [www.supermicro.com](http://www.supermicro.com)

### Europe

Address: Super Micro Computer B.V.  
Het Sterrenbeeld 28, 5215 ML  
's-Hertogenbosch, The Netherlands

Tel: +31 (0) 73-6400390

Fax: +31 (0) 73-6416525

Email: [sales@supermicro.nl](mailto:sales@supermicro.nl) (General Information)  
[support@supermicro.nl](mailto:support@supermicro.nl) (Technical Support)  
[rma@supermicro.nl](mailto:rma@supermicro.nl) (Customer Support)

Website: [www.supermicro.nl](http://www.supermicro.nl)

### Asia-Pacific

Address: Super Micro Computer, Inc.  
3F, No. 150, Jian 1st Rd.  
Zhonghe Dist., New Taipei City 235  
Taiwan (R.O.C)

Tel: +886-(2) 8226-3990

Fax: +886-(2) 8226-3992

Email: [support@supermicro.com.tw](mailto:support@supermicro.com.tw)

Website: [www.supermicro.com.tw](http://www.supermicro.com.tw)

# Chapter 1

## Introduction

### 1.1 Overview

This chapter provides a brief outline of the functions and features of the SSG-136R-N32JBF. The SSG-136R-N32JBF is a JBOF system based on the 136TS-R1K04JP-U2 chassis and the BPN-NVME3-136PL-J controller board.

In addition to the controller board and chassis, several important parts that are included with the system are listed below.

Main Parts List		
Description	Part Number	Quantity
Controller Board	BPN-NVME3-136PL-J	1
Drive Backplane	BPN-NVME3-136NB-L / BPN-NVME3-136NB-R	2 each
JBOF Switch Board	BPN-NVME3-136PL	2
Hot-swap SSD Carriers	MCP-220-00149-06	32
System Fans	FAN-0188L4	8
Rack Rail Mounting Kit	MCP-290-11809-0N	1
Optional Riser Card	RSC-X-6-JBOF	2

The following safety models associated with the SSG-136R-N32JBF have been certified as compliant with UL or CSA: 136U2JBOF-10, 136-10.

### 1.2 Unpacking the System

Inspect the box the SuperStorage SSG-136R-N32JBF was shipped in and note if it was damaged in any way. If any equipment appears damaged, please file a damage claim with the carrier who delivered it.

Decide on a suitable location for the rack unit that will hold the system. It should be situated in a clean, dust-free area that is well ventilated. Avoid areas where heat, electrical noise and electromagnetic fields are generated. A grounded AC power outlet is also required. Read the precautions and considerations noted in Appendix A.

## 1.3 System Features

The following table provides you with an overview of the main features of the SSG-136R-N32JBF. Refer to Appendix B for additional specifications.

<b>System Features</b>
<b>Controller Board</b>
BPN-NVME3-136PL-J
<b>Chassis</b>
CSE-136TS-R1K04JP-U2
<b>Expansion Slots</b>
Two PCI Express 3.0 x16 Slots Four External PCI Express 3.0 x16 Ports
<b>Drives</b>
Thirty-two 2.5" NVMe SSDs in hot-swap drive carriers
<b>Power</b>
Dual (redundant) 1000W power supply modules (p/n PWS-1K04A-1R)
<b>Form Factor</b>
1U rackmount
<b>Dimensions</b>
(WxHxD) 17.26 x 1.71 x 31.95 in. (438.4 x 43.6 x 811.7 mm)

## 1.4 System Chassis Features

### Control Panels

The switches and LEDs located on the control panels are described below. Two control panels are located on the front of the chassis.

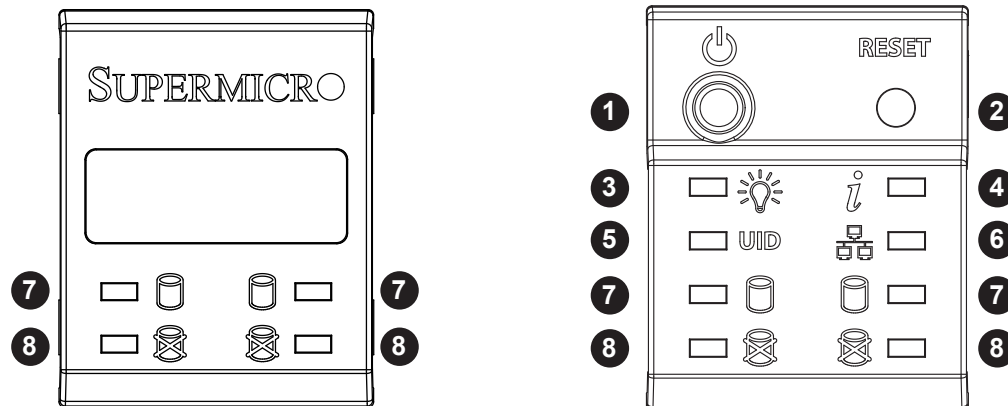

Figure 1-1. Control Panel View

Control Panel Features		
Item	Feature	Description
1	Power Button	The main power button is used to apply or remove power from the power supply to the system. Turning off system power with this button removes the main power but maintains standby power. To perform many maintenance tasks, you must also unplug system before servicing. <b>Note:</b> Before applying power to the system, refer to Section 2.4, "Powering On the System."
2	Reset Button	The reset button is used to reset the system.
3	Power LED	Indicates power is being supplied to the system power supply. This LED should normally be illuminated when the system is operating.
4	Information LED	Indicates one of multiple possible conditions. (See Information LED table on following page.)
5	UID LED	Illuminates when the UID button is activated. Use this to easily identify the system in a rack.
6	IPMI LED	Indicates activity from the IPMI LAN ports.
7	Sled Activity LEDs	Indicates the combined activity of the SSDs in this side of the sled. (See Sled Activity/Status LEDs table on the following page.)
8	Sled Status LEDs	Indicates the combined status of the SSDs in this side of the sled. (See Sled Activity/Status LEDs table on the following page). To see status of a specified drive, extend the sled and view the LEDs on the top of the sled.

Information LED	
Status	Description
Solid red	Power supply failure.
Blinking red (1Hz)	Fan failure. Check for an inoperative fan.
Blinking red (4Hz)	BMC service is powering on. Do not power on hosts connected to the system until this is finished. Refer to Section 2.4.

Sled Activity/Status LEDs		
	Status	Description
Activity LED	Solid blue	Idle NVMe drive detected.
	Blinking blue	I/O activity.
	Off	No drive detected.
Status LED	Solid red	Drive failure. Extend chassis sled to identify failed drive.
	Blinking red (4Hz)	Drive identifier. Use IPMI to activate this status, which allows you to quickly identify a specified drive.

## Front Features

The 136TS-R1K04JP-U2 is a two-sled 1U chassis. See the illustration below for the features included on the front of the chassis.

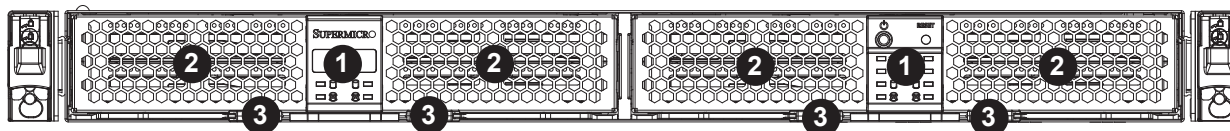

Figure 1-2. Chassis Front View

Front Chassis Features		
Item	Feature	Description
1	Control Panels	Front control panels with LEDs and buttons (see preceding page)
2	Drive Bays	Bay that houses eight hot-swappable 2.5" SSDs
3	Sled Latch	Latch for releasing and extending the sled from the chassis

## Rear Features

The illustration below shows the features included on the rear of the chassis.

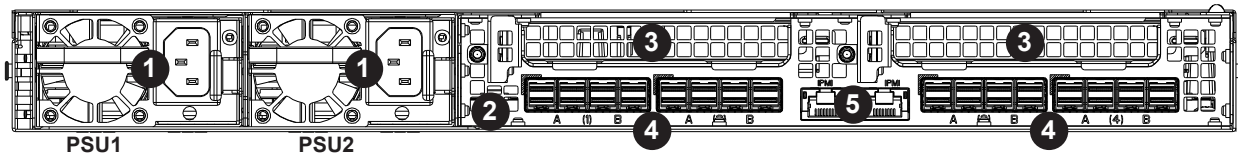

Figure 1-4. Chassis Rear View

Rear Chassis Features		
Item	Feature	Description
1	Power Supply	1000W power supply module with LED. Two modules for power redundancy (PSU1 on left, PSU2 on right). (See Power Supply LED table.)
2	UID Button	Press this button to activate the UID LED, which allows you to quickly identify the system in a rack.
3	Expansion Card Slots	Slots for expansion cards.
4	External PCIe Ports	External x16 PCIe ports (see Section 1.6).
5	IPMI LAN Ports	Rear IPMI LAN ports (see Section 1.6).

Power Supply LED	
Status	Description
Solid green	Power supply is providing power to the system.
Solid amber	Power supply is plugged in and deactivated, or the system is powered off but in an abnormal state.
Blinking amber	Power supply temperature has reached 63 °C. The system automatically powers off if the temperature rises to 70 °C, and automatically resets when the temperature falls below 60 °C.

## Sled Features

The chassis contains two sleds that each hold 16 NVMe SSDs. The sleds extend from the front of the chassis to provide access to hot-swap drive carriers located on each side of the sled. Refer to Chapter 3 for instructions on accessing the drive carriers.

The illustration below shows the features included on each side of both chassis sleds.

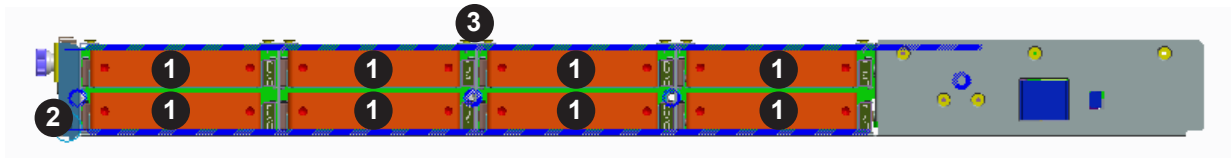

Figure 1-5. Sled Side View

Sled Features		
Item	Feature	Description
1	Hot-swap Drive Carrier	Tool-less drive carrier for 2.5" NVMe SSD.
2	Sled Latches	Latches for extending the sled from the chassis.
3	Drive Carrier LEDs	One LED for each drive carrier in the sled. Each LED indicates the status of the drive. (See following Drive Carrier LED table.)

Drive Carrier LED		
	Status	Description
Status LED	Solid red	Drive failure.
	Blinking red (4Hz)	Drive identifier. Use IPMI to activate this status, which allows you to quickly identify a specified drive.



## 1.5 Controller Board Layout

Below is a layout of the BPN-NVMe3-136PL-J. See the following table for jumper descriptions.

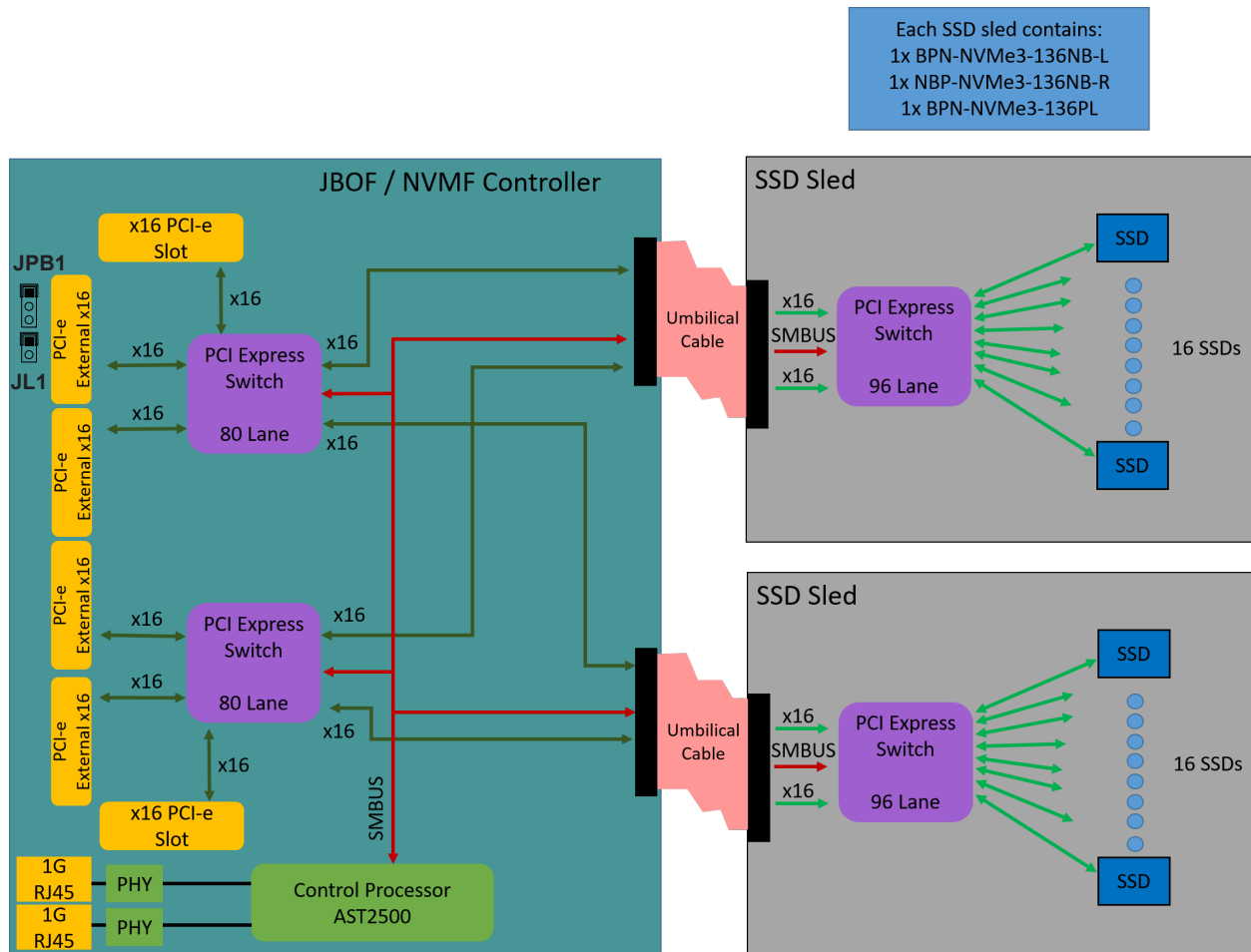

Figure 1-6. Controller Board Layout

### Quick Reference Table

Jumper	Description	Default Setting
JPB1	BMC Enable	Pins 1-2 (Enabled)
JL1	Chassis Intrusion	Open

**Note:** BMC must always be enabled. Do *not* disable BMC.

## 1.6 Ports

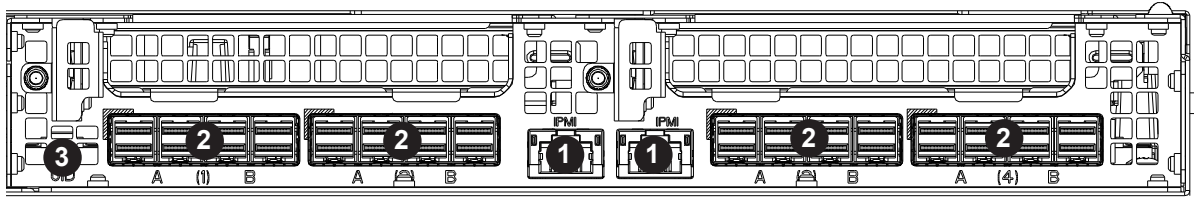

Figure 1-7. Rear I/O Panel

#	Description
1	IPMI LAN Ports
2	x16 PCIe External Port
3	UID Button

### IPMI LAN Ports

Two 1G IPMI LAN ports (LAN1/2) are located on the I/O back panel. If both ports are plugged in, LAN1 is the active port and LAN2 is redundant. If only one LAN port is used, LAN2 is preferred. LAN2 is the left port and LAN1 is the right port.

Refer to the LED Indicator section for LAN LED information.

### Unit Identifier Button

A Unit Identifier (UID) button and a rear LED Indicator (UID-LED) are located on the I/O back panel. When the user presses the UID button, the UID LED indicator will be turned on. Press the UID button again to turn off the UID LED. The UID indicator provides easy identification of a system unit that may be in need of service.

**Note:** UID can also be triggered via IPMI on the controller board. For more information on IPMI, please refer to the IPMI User's Guide posted on our website at <http://www.supermicro.com>.

### External PCIe Ports

Four x16 external PCIe ports are located on the I/O back panel. These ports can be split into eight x8 ports to support eight hosts.

# Chapter 2

## System Installation

### 2.1 Overview

This chapter provides advice and instructions for mounting your system in a server rack. If your system is not already fully integrated with drives, fans etc., refer to Chapter 3 for details on installing those specific components.

**Caution:** Electrostatic Discharge (ESD) can damage electronic components. To prevent such damage to PCBs (printed circuit boards), it is important to use a grounded wrist strap, handle all PCBs by their edges and keep them in anti-static bags when not in use.

### 2.2 Preparing for Setup

The box in which the system was shipped should include the rackmount hardware needed to install it into the rack. Please read this section in its entirety before you begin the installation.

#### Choosing a Setup Location

- The system should be situated in a clean, dust-free area that is well-ventilated. Avoid areas where heat, electrical noise, and electromagnetic fields are generated.
- Leave at least 25 inches of clearance in front of the rack so that you can open the front door completely. Leave approximately 30 inches of clearance behind the rack to allow sufficient space for airflow and access when servicing.
- This product should be installed only in a Restricted Access Location (dedicated equipment rooms, service closets, etc.).
- This product is not suitable for use with visual display workplace devices according to §2 of the German Ordinance for Work with Visual Display Units.

#### Rack Precautions

- Verify that the leveling jacks on the bottom of the rack are extended to the floor so that the full weight of the rack rests on them.

- In single rack installations, stabilizers should be attached to the rack. In multiple rack installations, the racks should be coupled together.
- Always verify that the rack is stable before extending a server or other component from the rack.
- You should extend only one server or component at a time. Extending two or more simultaneously might cause the rack to become unstable.

## **System Precautions**

- Review the electrical and general safety precautions in Appendix A.
- Determine the placement of each component in the rack *before* you install the rails.
- Install the heaviest components at the bottom of the rack first. Subsequent components should be installed in decreasing order of weight.
- Use a regulating uninterruptible power supply (UPS) to protect the system from power surges and voltage spikes and to keep your system operating in case of a power failure.
- Allow any drives and power supply modules to cool before touching them.
- When not servicing, always keep the front door of the rack and all covers and panels closed to maintain proper cooling.

## **Rack Mounting Considerations**

### ***Ambient Operating Temperature***

If installed in a closed or multi-unit rack assembly, the ambient operating temperature of the rack environment may be greater than the room's ambient temperature. Therefore, consideration should be given to installing the equipment in an environment compatible with the manufacturer's maximum rated ambient temperature (TMRA).

### ***Airflow***

Equipment should be mounted into a rack so that the amount of airflow required for safe operation is not compromised.

### ***Mechanical Loading***

Equipment should be mounted into a rack so that a hazardous condition does not arise due to uneven mechanical loading.

### ***Circuit Overloading***

Consideration should be given to the connection of the equipment to the power supply circuitry and the effect that any possible overloading of circuits might have on overcurrent protection and power supply wiring. Appropriate consideration of equipment nameplate ratings should be used when addressing this concern.

### ***Reliable Ground***

A reliable ground must be maintained at all times. To ensure this, the rack itself should be grounded. Particular attention should be given to power supply connections other than the direct connections to the branch circuit (i.e. the use of power strips, etc.).



To prevent bodily injury when mounting or servicing this unit in a rack, you must take special precautions to ensure that the system remains stable. The following guidelines are provided to ensure your safety:

- This unit should be mounted at the bottom of the rack if it is the only unit in the rack.
- When mounting this unit in a partially filled rack, load the rack from the bottom to the top with the heaviest component at the bottom of the rack.
- If the rack is provided with stabilizing devices, install the stabilizers before mounting or servicing the unit in the rack.



Slide rail mounted equipment is not to be used as a shelf or a work space.



**Warning:** Do not pick up the system with the front handles. They are designed to pull the system from a rack only.

## 2.3 Installing the System into a Rack

This section provides information on installing the 136TS-R1K04JP-U2 chassis into a rack unit with the rails provided. Due to the variety of rack units on the market, the assembly procedure might differ slightly. You should also refer to the installation instructions that came with the rack unit you are using.

### Identifying the Sections of the Rack Rails

The SSG-136R-N32JBF includes two rack rail assemblies in the rack mounting kit. Each assembly consists of three sections: An inner chassis rail which secures directly to the chassis, an outer rail that secures to the rack, and a middle rail which extends from the outer rail. These assemblies are specifically designed for the left and right side of the chassis.

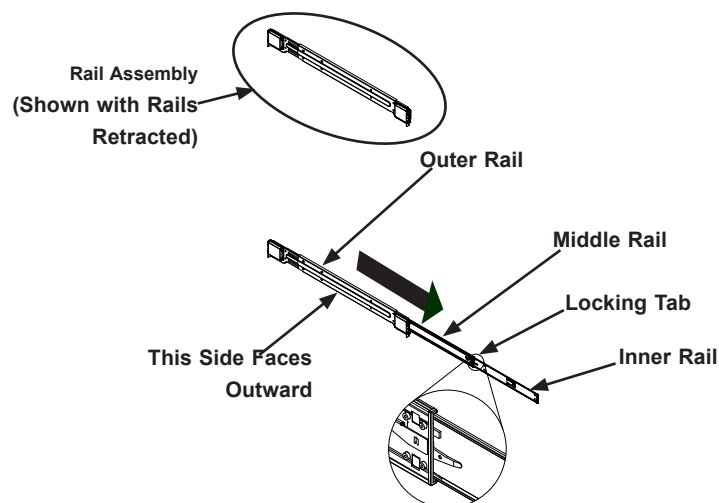

**Figure 2-1. Identifying the Rail Sections**

**Note:** Both front chassis rails and the rack rails have a locking tab, which serves two functions. First, it locks the system into place when installed and pushed fully into the rack (its normal operating position). In addition, these tabs lock the system in place when fully extended from the rack. This prevents the system from coming completely out of the rack when pulled out for servicing.

## Releasing the Inner Rails

### *Releasing the Inner Rails from the Outer Rails*

1. Pull the inner rail out of the outer rail until it is fully extended as illustrated below.
2. Press the locking tab down to release the inner rail.
3. Fully extend the inner rail.
4. Repeat steps 1-3 for the second outer rail.

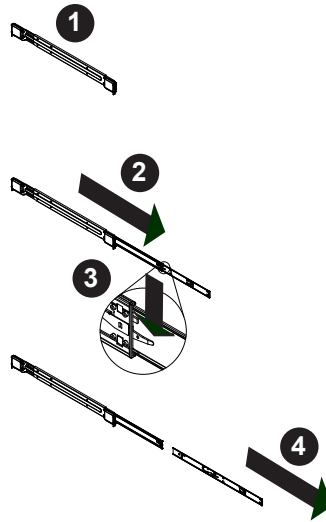

**Figure 2-2. Extending and Releasing the Inner Rails**



**Warning:** Stability hazard. The rack stabilizing mechanism must be in place, or the rack must be bolted to the floor before you slide the unit out for servicing. Failure to stabilize the rack can cause the rack to tip over.

## Installing The Inner Rails on the Chassis

### *Installing the Inner Rails*

1. Place the inner rail firmly against the side of the chassis, aligning the hooks on the side of the chassis with the holes in the inner rail.
2. Slide the inner rail forward toward the back of the chassis until the rail clicks into the locked position, which secures the inner rail to the chassis.
3. Secure the inner rail to the chassis with the screws provided.
4. Repeat steps 1-3 for the second inner rail.

**Note:** Chassis pictured may vary slightly from the SSG-136R-N32JBF system chassis.

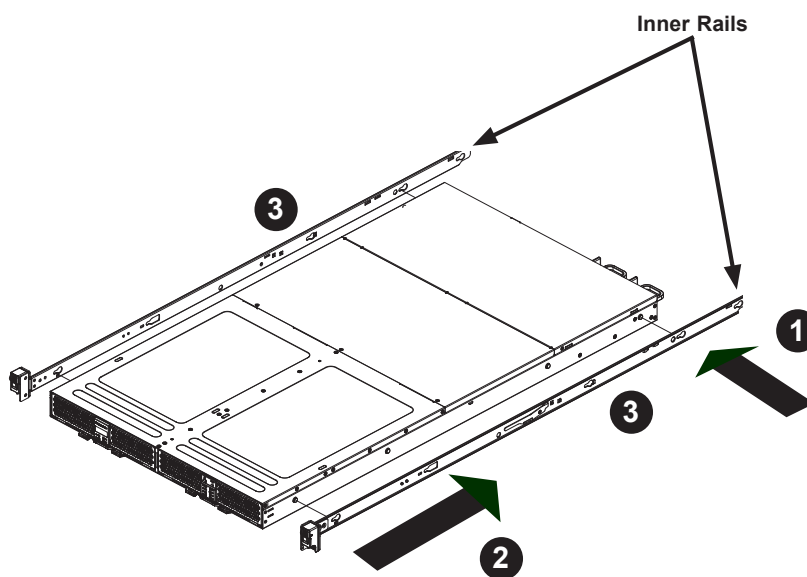

**Figure 2-3. Installing the Inner Rails**



**Warning:** In any instance of pulling the system from the rack, always use a rack lift and follow all associated safety precautions.



**Warning:** When initially installing the system to a rack, test that the rail locking tabs engage to prevent the system from being overextended. Have a rack lift in place as a precaution in case the test fails.



## Installing the Outer Rails on the Rack

### Installing the Outer Rails

1. If your rack has round mounting holes, adjust the fittings on the outer rails. Press the latch at the end of the rail to change from square fittings to round fittings.

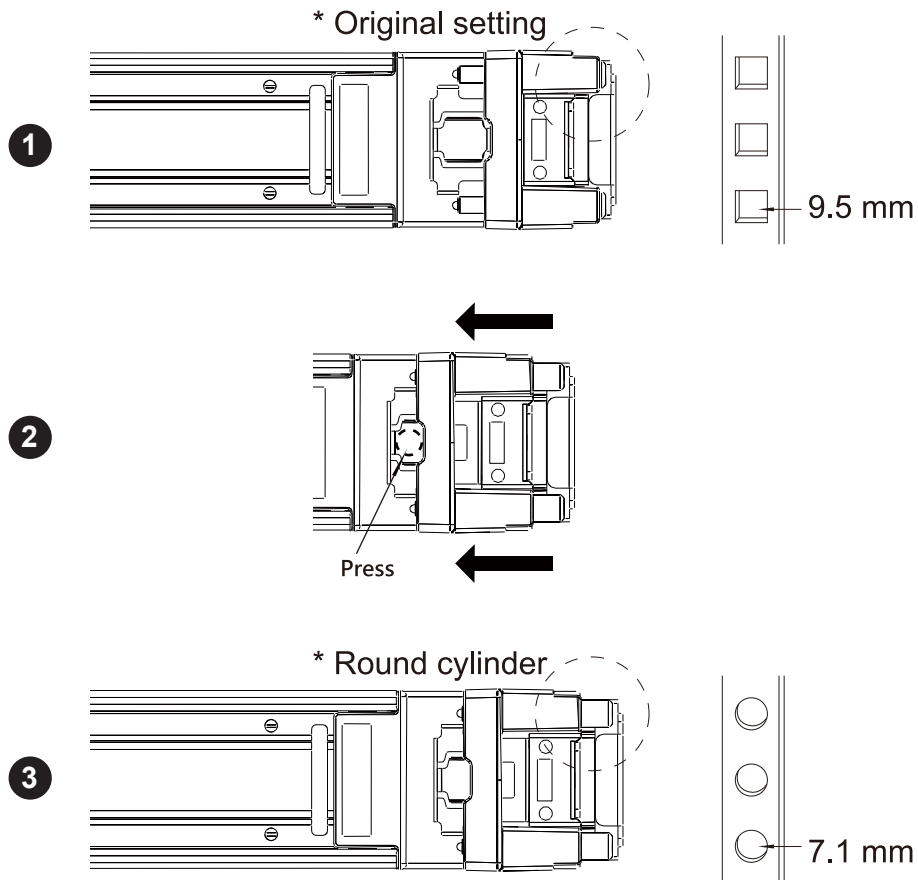
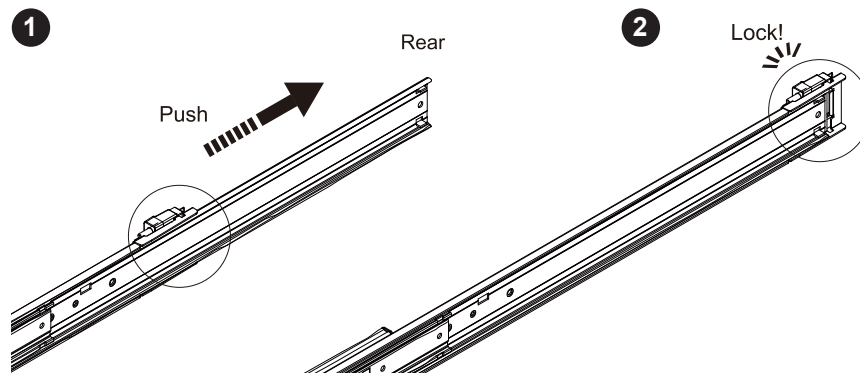

Figure 2-4. Adjusting Outer Rail Fittings

2. Push the middle rail back into the outer rail. An audible click indicates that the rail is fully inserted.



**Figure 2-5. Adjusting the Middle Rail**

3. Insert the pegs on the rear of the outer rail into the rear rack holes. An audible click indicates that the rail is locked into place.
4. Press upward on the locking tab near the rear end of the middle rail, and extend the outer rail until the length fits within the posts of the rack.
5. On the front end of the outer rail, turn the latch to the open position and push the pegs into the front rack holes.
6. Turn the latch to the locked position.
7. Repeat steps 1-6 for the remaining outer rail.

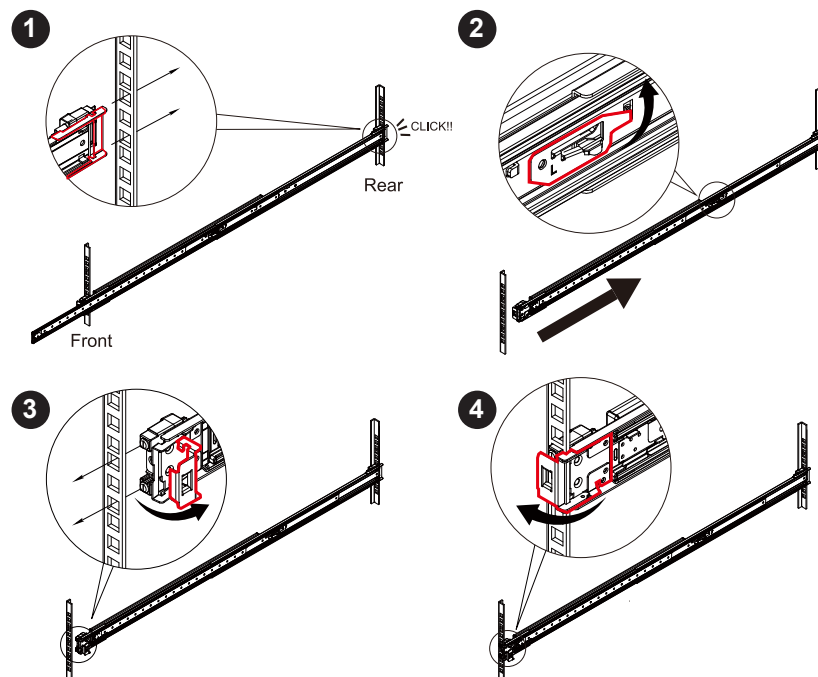

**Figure 2-6. Installing Outer Rails to a Rack**

## Installing the Chassis onto the Rack

### *Installing the Chassis onto the Rack*

1. Fully extend the outer rails as illustrated in Figure 2-7.
2. Align the inner rails of the chassis with the outer rails on the rack.
3. Slide the inner rails into the outer rails, keeping pressure even on both sides. Hold down the locking lever on the inner rail to push the chassis fully onto the rack. An audible click indicates that the chassis is secured into the rails.



**Warning:** Mounting the system into the rack requires at least two people to support the chassis during installation. Follow safety recommendations printed on the rails.

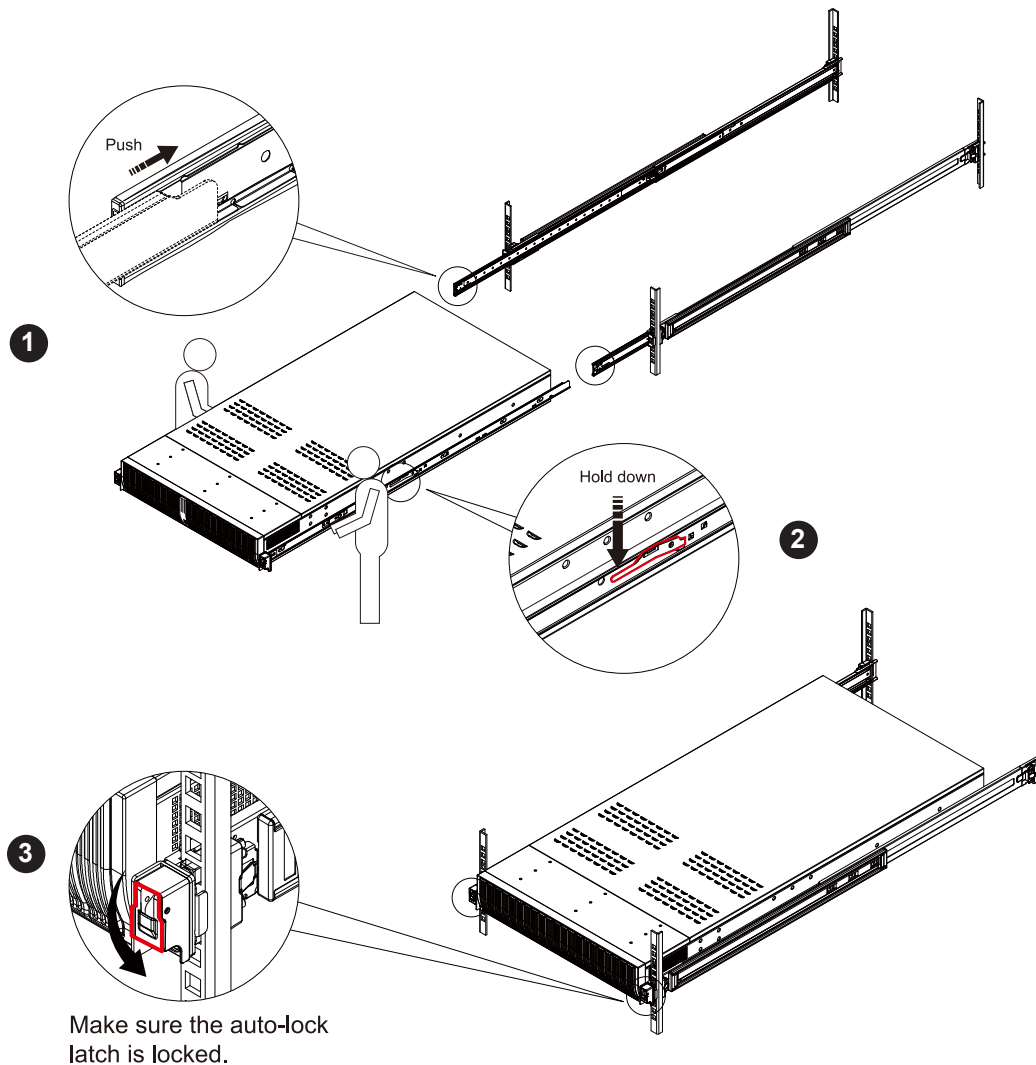

**Figure 2-7. Installing the System into a Rack**

## 2.4 Powering On the System

Any time you power on the SSG-136R-N32JBF system, first perform the following precautions:

1. Verify that all hosts that will use the SSG-136R-N32JBF are powered off.
2. Connect PCIe cabling from the hosts to the SSG-136R-N32JBF.
3. Connect a power cable from a grounded AC outlet to the SSG-136R-N32JBF. Do *not* power on the system.
4. Wait two minutes for the BMC service to power on.
5. Press the power button on the SSG-136R-N32JBF, or power on the system using the IPMI command interface.
6. Wait three minutes, then power on the hosts that are connected to the system. Refer to the "Information LED" table in Section 1.4.

## 2.5 Assigning Drives to Host Servers

When you boot up the system for the first time, you must assign the NVMe drives to attached hosts. You can view and modify drive assignment using the Web GUI or the command line. Refer to your preferred procedure in Appendix C.

## Chapter 3

# Maintenance and Component Installation

This chapter provides instructions on installing and replacing main system components. To prevent compatibility issues, only use components that match the specifications and/or part numbers given.

Installation or replacement of most components require that power first be removed from the system. Please follow the procedures given in each section.

### 3.1 Removing Power

Use the following procedure to ensure that power has been removed from the system. This step is necessary when removing or installing non hot-swap components or when replacing a non-redundant power supply.

1. Use IPMI to power down the system.
2. After the system has completely shut-down, disconnect the AC power cord(s) from the power strip or outlet. (If your system has more than one power supply, remove the AC power cords from all power supply modules.)
3. Disconnect the power cord(s) from the power supply module(s).

### 3.2 Accessing the System

The 136TS-R1K04JP-U2 chassis features a removable top cover, which allows easy access to the inside of the chassis.

#### ***Removing the Top Cover***

1. Remove power from the system as described in Section 3.1.
2. Remove the screws securing the middle panel to the chassis.
3. Lift the middle panel up and off the chassis.
4. Remove the screws securing the second panel to the chassis.
5. Slide the second panel toward the rear of the chassis and lift it off.

**Warning:** Except for short periods of time, do not operate the system without the cover in place. The chassis cover must be in place to allow for proper airflow and to prevent overheating.

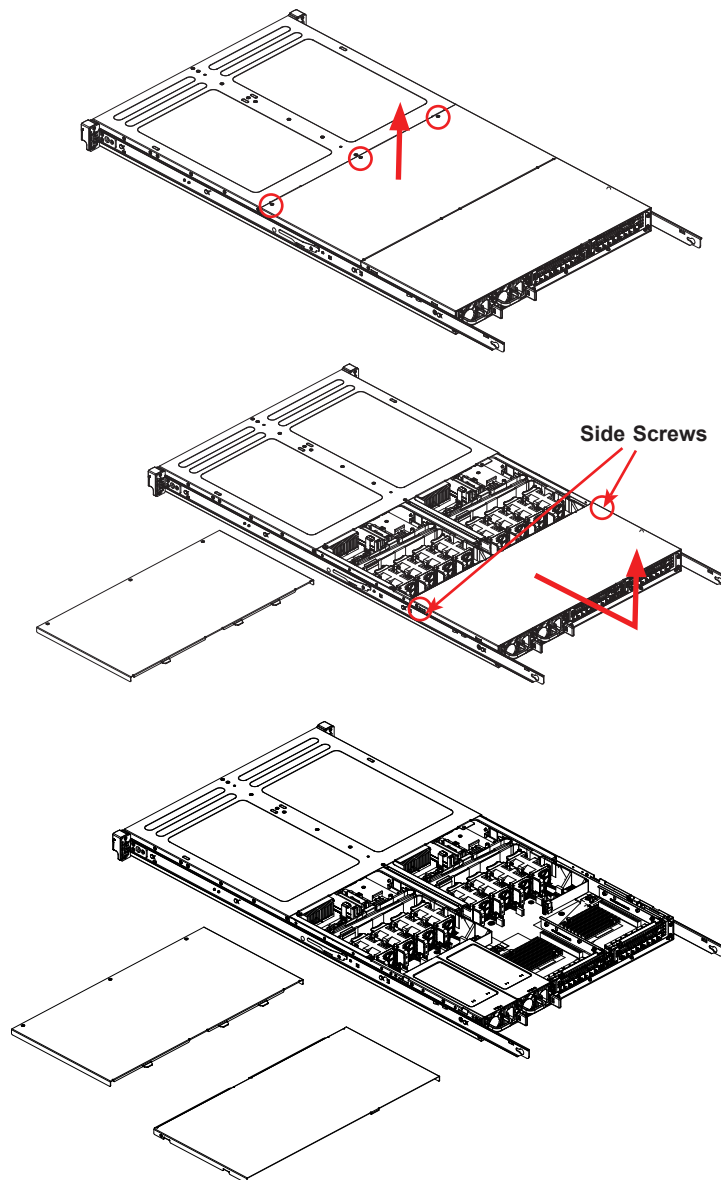

Figure 3-1. Removing the Chassis Cover

## 3.3 Chassis Components

### Drives

Your system may or may not have come with drives installed. Up to thirty-two hot-swappable 2.5" NVMe SSDs are supported by the chassis (16 drives in each sled).

The drives are mounted in drive carriers to simplify their installation and removal from the chassis. (Both procedures may be done without removing power from the system.)

#### **Extending a Sled**

1. For one sled, swing both sled latches fully out.
2. Grasp the sled latches and use them to extend the sled out of the chassis.

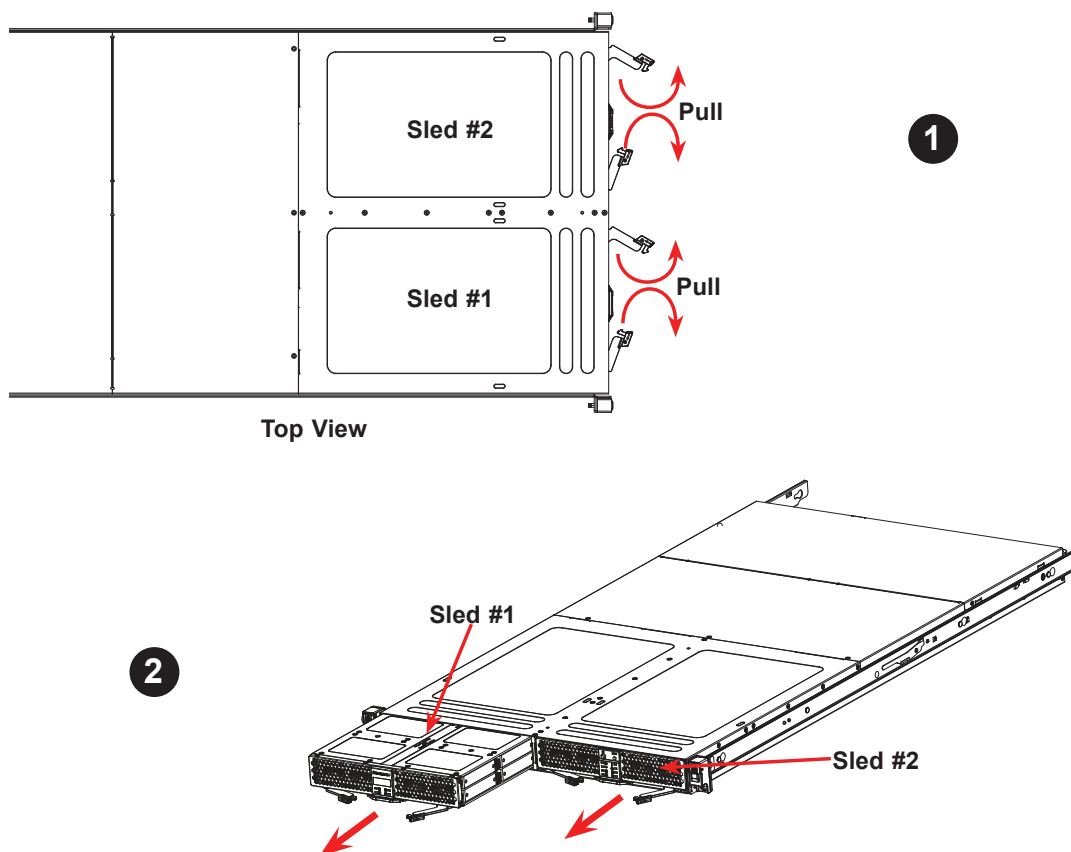

Figure 3-2. Extending the Sled

**Notes:** 1. Do not leave a sled extended from the chassis for longer than two minutes. 2. Use Supermicro qualified NVMe SSDs only. For information on recommended SSDs, visit the Supermicro website at <http://www.supermicro.com/products/nfo/storage.cfm>.

### Mounting a Drive in a Drive Carrier

1. Release and swing open the locking latches on the side of the drive carrier.
2. Insert a drive into the carrier with the PCB side facing down and the connector end toward the rear of the carrier. Insert the drive at an angle as shown in Figure 3-3. Verify that the mounting holes on the drive align with the mounting holes on the carrier.
3. Swing both locking latches shut. An audible click indicates that the drive is locked in place.
4. Insert the drive and drive carrier into its bay. When the drive is fully inserted, push the release tab until it clicks shut. Refer to Figure 3-4.

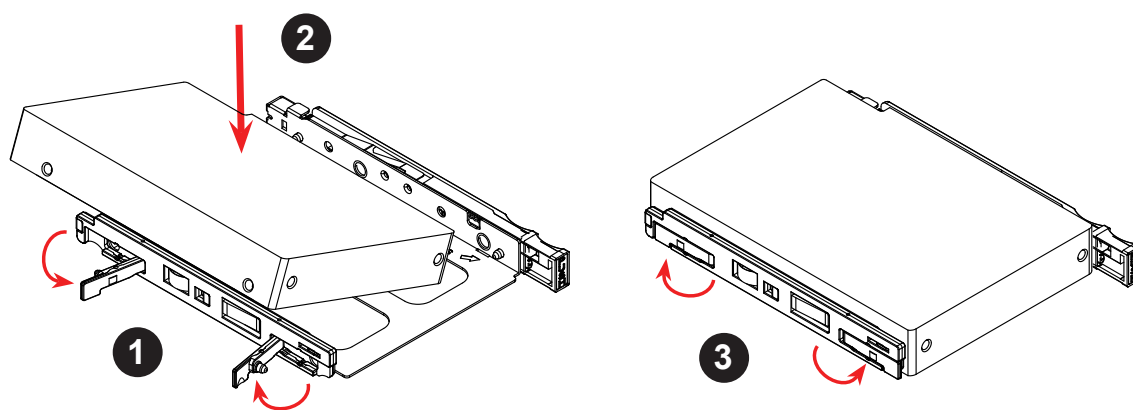

Figure 3-3. Mounting a Drive in a Carrier

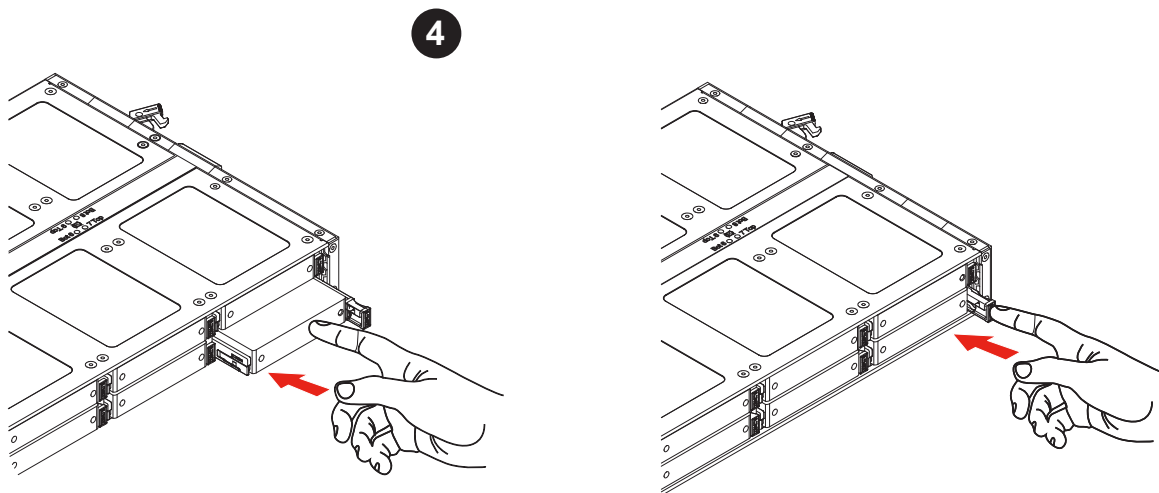
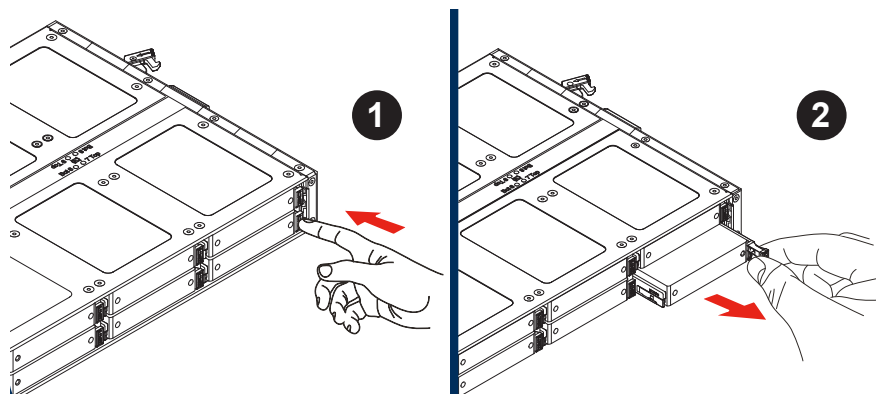

Figure 3-4. Installing a Drive Carrier into the Sled



### ***Removing a Drive***

1. Push the release tab on the drive carrier that you want to remove.
2. Use the release tab to retract the drive carrier from its bay, then fully remove the drive carrier and its drive.
3. Release and swing open the locking latches on the side of the drive carrier.
4. Remove the drive from its carrier at an angle as shown in Figure 3-6.



**Figure 3-5. Removing a Drive Carrier from a Sled**

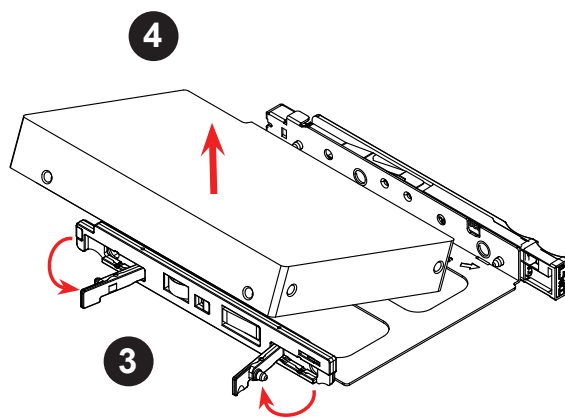

**Figure 3-6. Removing a Drive from a Carrier**

## System Cooling

Eight 4-cm hot-swap fans provide the cooling for the system. It is very important that the chassis top cover is properly installed and forms a seal in order for the cooling air to circulate properly through the chassis and cool the components.

### *Replacing a Fan*

1. If necessary, open the chassis while the power is running to determine which fan requires changing. (Never run the system for an extended period of time with the chassis open.)
2. Open the chassis cover.
3. Remove the failed fan from the chassis.
4. Place the new fan into the vacant space in the housing while making sure the arrows on the top of the fan (indicating air direction) point in the same direction as the arrows on the other fans.

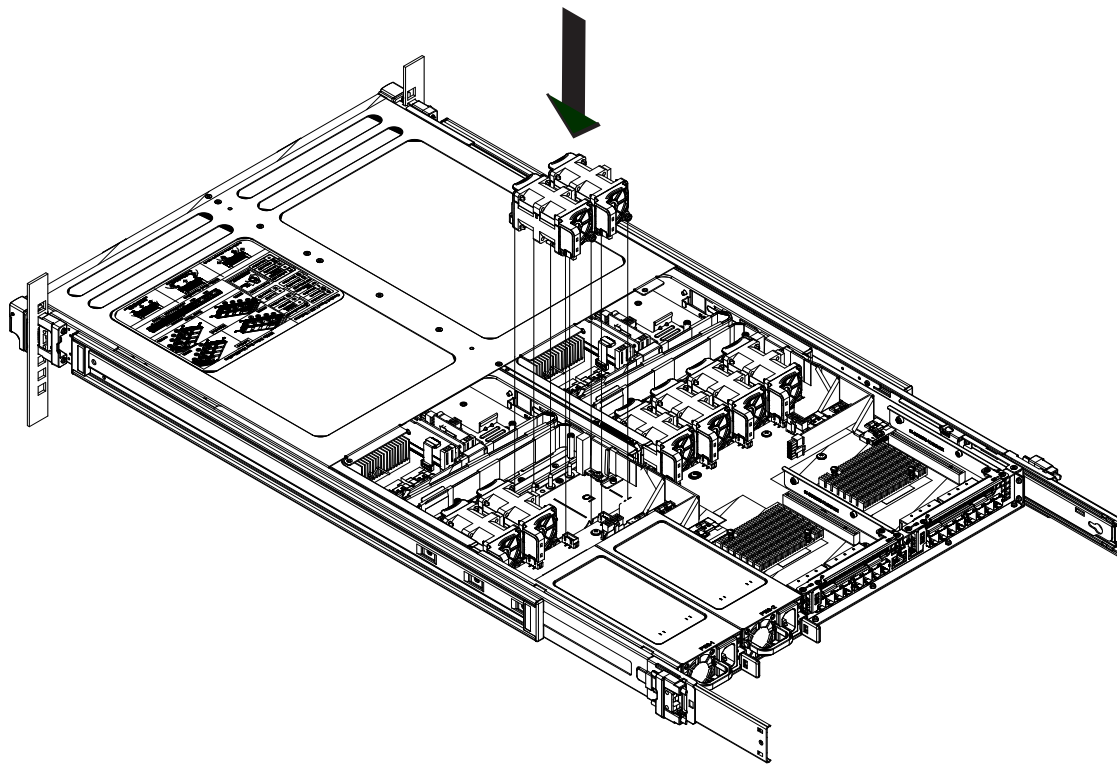

**Figure 3-7. Installing a System Fan**

## Power Supply

The SSG-136R-N32JBF has a 1000W redundant, hot-plug power supply consisting of two power modules. Each power supply module has an auto-switching capability, which enables it to automatically sense and operate at a 100V - 240VAC input voltage.

### ***Power Supply Failure***

If either of the two power supply modules fail, the other will take the full load and allow the system to continue operation without interruption. The Power Fail LED illuminates until the failed module has been replaced. Replacements can be ordered directly from Supermicro (see contact information in the Preface). The power supply modules have a hot-swap capability, so you can replace the failed module without powering down the system.

Replacement units can be ordered directly from Supermicro. The power supply units have a hot-swap capability, meaning you can replace the failed unit without powering down the system.

### ***Removing/Replacing the Power Supply***

1. Unplug the power cord from the failed power supply module.
2. Push the release tab on the back of the power supply.
3. Pull the power supply out using the handle provided.
4. Replace the failed power module with another of the same model.
5. Push the new power supply module into the power bay until it clicks into the locked position.
6. Plug the AC power cord back into the module.

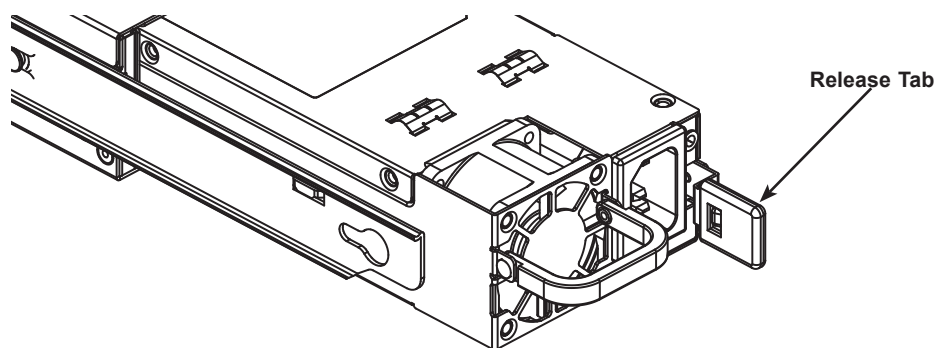

**Figure 3-8. Removing/Replacing a Power Supply**

## PCIe Cables

PCIe cabling is required to connect the SSG-136R-N32JBF to the server node's host interface card(s). The chassis has four x16 external PCIe ports, which can be split to eight x8 ports to support up to eight hosts.

Connect the PCIe cable from the server node's host interface card (P/N AOC-SLG3-4X4P) to the first set of ports. For each host, the top cable from the interface card (port A) must be plugged into port A on the system, and the bottom cable from the interface card (port B) must be plugged into port B on the system. To support additional hosts, connect PCIe cables to the subsequent ports. If using only two hosts, connect each host to a different PCIe switch for improved performance (see Figure 3-9).

The following diagrams show three potential configurations for the SSG-136R-N32JBF: A single server with multiple interface cards and dual x8 PCIe cables, four servers with dual x8 PCIe cables, and eight servers with single x8 PCIe cables.

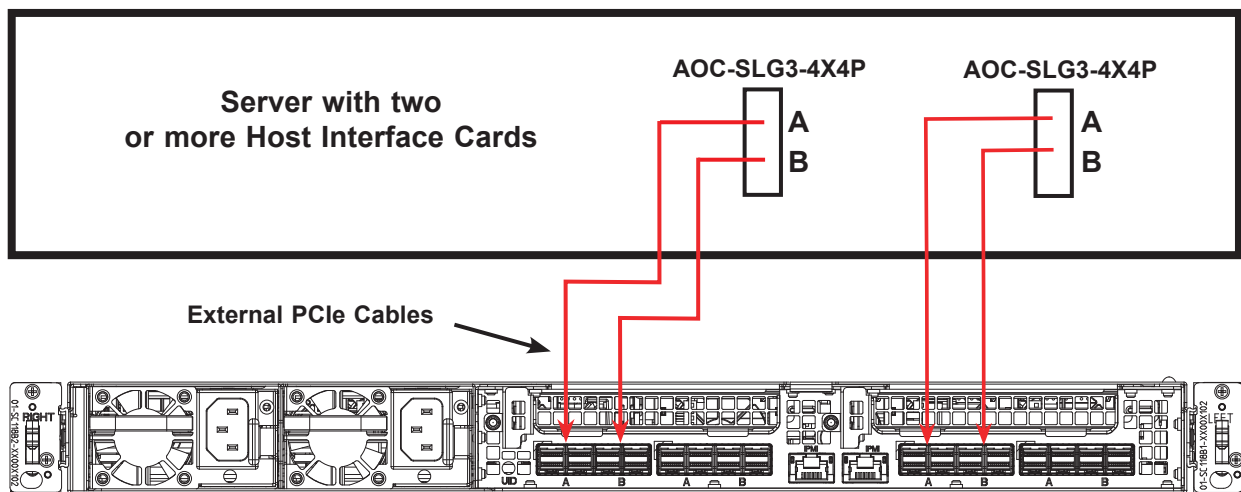

**Figure 3-9. Single Server with Multiple Interface Cards (Dual x8 PCIe Cables)**

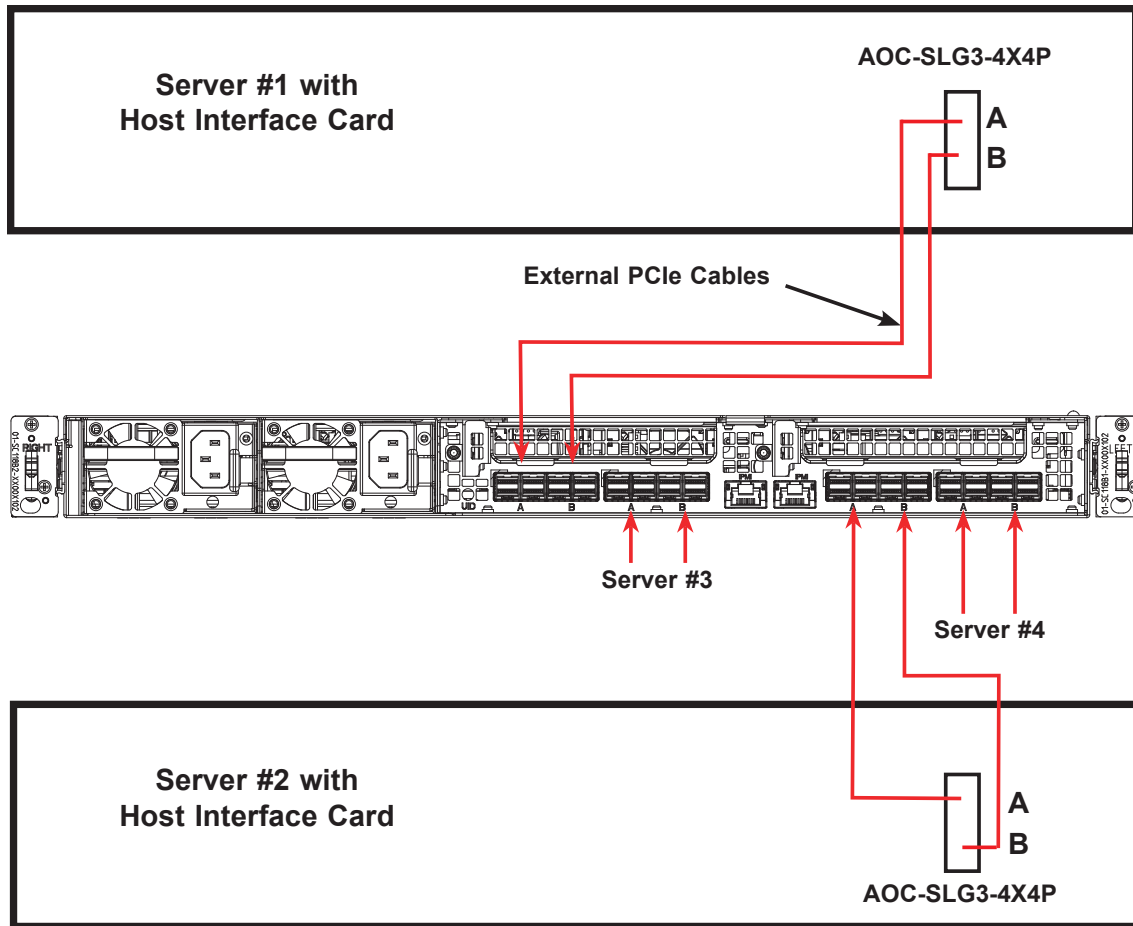

Figure 3-10. Four Servers (Dual x8 PCIe Cables)

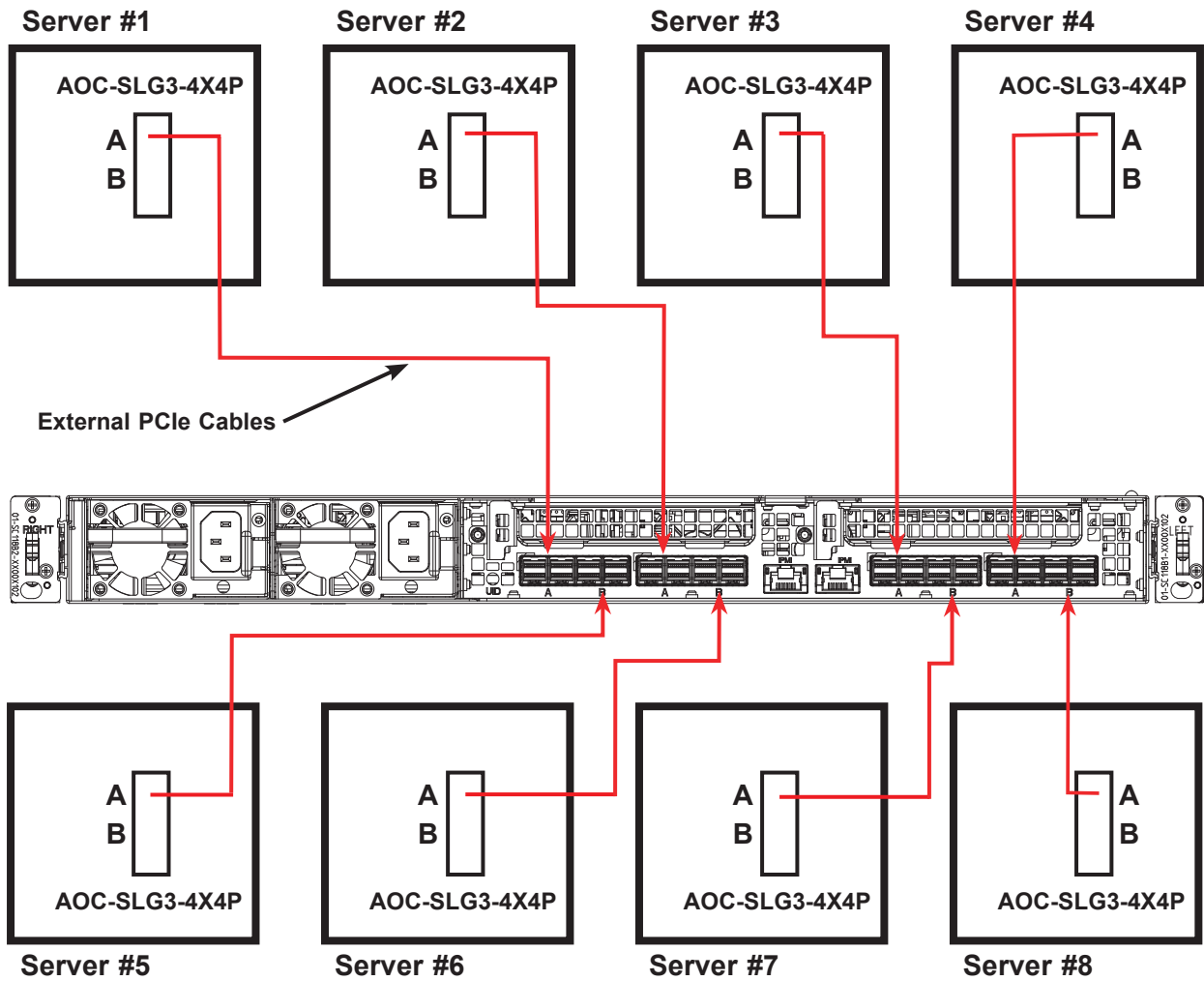

Figure 3-11. Eight Servers (Single x8 PCIe Cables)

## PCIe Expansion Cards

The SSG-136R-N32JBF can accommodate up to two full-height PCIe expansion cards in the rear slots. These are only used for NVMeoF configurations, 6-host configurations, and 12-host configurations.

### ***Installing an Add-on Card***

Begin by removing power from the system as described in Section 3.1 and removing the cover as described in Section 3.2.

1. Remove the shield for the PCIe slot that you wish to populate. Verify that the card you are installing is supported by the slot.
2. Seat the card firmly into the slot by pushing down with your thumbs evenly on both sides of the card.
3. Use a screw to secure the top of the card shield to the chassis. The PCIe slot shields protect the motherboard and its components from EMI and aid in proper ventilation, so verify that each unused slot is covered by a shield.

## Appendix A

# Standardized Warning Statements for AC Systems

### A.1 About Standardized Warning Statements

The following statements are industry standard warnings, provided to warn the user of situations which have the potential for bodily injury. Should you have questions or experience difficulty, contact Supermicro's Technical Support department for assistance. Only certified technicians should attempt to install or configure components.

Read this appendix in its entirety before installing or configuring components in the Supermicro chassis.

These warnings may also be found on our website at [http://www.supermicro.com/about/policies/safety\\_information.cfm](http://www.supermicro.com/about/policies/safety_information.cfm).

#### Warning Definition



**Warning!** This warning symbol means danger. You are in a situation that could cause bodily injury. Before you work on any equipment, be aware of the hazards involved with electrical circuitry and be familiar with standard practices for preventing accidents.

#### 警告の定義

この警告サインは危険を意味します。

人身事故につながる可能性がありますので、いずれの機器でも動作させる前に、電気回路に含まれる危険性に注意して、標準的な事故防止策に精通して下さい。

此警告符号代表危險。

您正处于可能受到严重伤害的工作环境中。在您使用设备开始工作之前，必须充分意识到触电的危险，并熟练掌握防止事故发生的标准工作程序。请根据每项警告结尾的声明号码找到此设备的安全性警告说明的翻译文本。

此警告符號代表危險。

您目前所處的工作環境可能讓您受傷。在您使用任何設備之前，請注意觸電的危險，並且要熟悉預防事故發生的標準工作程序。請依照每一注意事項後的號碼找到相關的翻譯說明內容。



## Warnung

## WICHTIGE SICHERHEITSHINWEISE

Dieses Warnsymbol bedeutet Gefahr. Sie befinden sich in einer Situation, die zu Verletzungen führen kann. Machen Sie sich vor der Arbeit mit Geräten mit den Gefahren elektrischer Schaltungen und den üblichen Verfahren zur Vorbeugung vor Unfällen vertraut. Suchen Sie mit der am Ende jeder Warnung angegebenen Anweisungsnummer nach der jeweiligen Übersetzung in den übersetzten Sicherheitshinweisen, die zusammen mit diesem Gerät ausgeliefert wurden.

BEWAHREN SIE DIESE HINWEISE GUT AUF.

## INSTRUCCIONES IMPORTANTES DE SEGURIDAD

Este símbolo de aviso indica peligro. Existe riesgo para su integridad física. Antes de manipular cualquier equipo, considere los riesgos de la corriente eléctrica y familiarícese con los procedimientos estándar de prevención de accidentes. Al final de cada advertencia encontrará el número que le ayudará a encontrar el texto traducido en el apartado de traducciones que acompaña a este dispositivo.

GUARDE ESTAS INSTRUCCIONES.

## IMPORTANTES INFORMATIONS DE SÉCURITÉ

Ce symbole d'avertissement indique un danger. Vous vous trouvez dans une situation pouvant entraîner des blessures ou des dommages corporels. Avant de travailler sur un équipement, soyez conscient des dangers liés aux circuits électriques et familiarisez-vous avec les procédures couramment utilisées pour éviter les accidents. Pour prendre connaissance des traductions des avertissements figurant dans les consignes de sécurité traduites qui accompagnent cet appareil, référez-vous au numéro de l'instruction situé à la fin de chaque avertissement.

CONSERVEZ CES INFORMATIONS.

תקנון הזהרות אזהרה

הזהרות הבאות הן אזהרות על פי תקני התעשייה, על מנת להזהיר את המשתמש מפני חבלה פיזית אפשרית. במידה ויש שאלות או היתקלות בבעיה כלשהי, יש ליצור קשר עם מחלקת תמיכה טכנית של סופרמיקרו. טכנאים מוסמכים בלבד רשאים להתקין או להגדיר את הרכיבים. יש לקרוא את הנספח במלואו לפני התקנת או הגדרת הרכיבים במארזי סופרמיקרו.

اَكْ ف حالة وُكِي اَي تتسبب ف اصابة جسدهُ هذا الزهز عُ خطر! تحذُرُ .  
قبل اَي تعول على اَي هعدات، كي على علن بالوخاطز ال اُجوة عي الذوائر  
الكهزبائِة  
وكي على دراةُ بالووارسات النقاائِة لو عُ وقع اَي حادث  
استخدم رِقن الب اِي الو صُص ف هَاةُ كل تحذُرُ للعشر تزجوتها

안전을 위한 주의사항

경고!

이 경고 기호는 위험이 있음을 알려 줍니다. 작업자의 신체에 부상을 야기 할 수 있는 상태에 있게 됩니다. 모든 장비에 대한 작업을 수행하기 전에 전기회로와 관련된 위험요소들을 확인하시고 사전에 사고를 방지할 수 있도록 표준 작업절차를 준수해 주시기 바랍니다.

해당 번역문을 찾기 위해 각 경고의 마지막 부분에 제공된 경고문 번호를 참조하십시오

## BELANGRIJKE VEILIGHEIDSINSTRUCTIES

Dit waarschuwings symbool betekent gevaar. U verkeert in een situatie die lichamelijk letsel kan veroorzaken. Voordat u aan enige apparatuur gaat werken, dient u zich bewust te zijn van de bij een elektrische installatie betrokken risico's en dient u op de hoogte te zijn van de standaard procedures om ongelukken te voorkomen. Gebruik de nummers aan het eind van elke waarschuwing om deze te herleiden naar de desbetreffende locatie.

BEWAAR DEZE INSTRUCTIES

## Installation Instructions



**Warning!** Read the installation instructions before connecting the system to the power source.

### 設置手順書

システムを電源に接続する前に、設置手順書をお読み下さい。

### 警告

将此系统连接电源前,请先阅读安装说明。

### 警告

將系統與電源連接前，請先閱讀安裝說明。

Warnung

Vor dem Anschließen des Systems an die Stromquelle die Installationsanweisungen lesen.

¡Advertencia!

Lea las instrucciones de instalación antes de conectar el sistema a la red de alimentación.

Attention

Avant de brancher le système sur la source d'alimentation, consulter les directives d'installation.

יש לקרוא את הוראות התקנה לפני חיבור המערכת למקור מתח.

اقر إرشادات التركيب قبل توصيل النظام إلى مصدر للطاقة

시스템을 전원에 연결하기 전에 설치 안내를 읽어주십시오.

Waarschuwing

Raadpleeg de installatie-instructies voordat u het systeem op de voedingsbron aansluit.

## Circuit Breaker



**Warning!** This product relies on the building's installation for short-circuit (overcurrent) protection. Ensure that the protective device is rated not greater than: 250 V, 20 A.

サーキット・ブレーカー

この製品は、短絡(過電流)保護装置がある建物での設置を前提としています。

保護装置の定格が250 V、20 Aを超えないことを確認下さい。

警告

此产品的短路(过载电流)保护由建筑物的供电系统提供,确保短路保护设备的额定电流不大于250V,20A。

警告

此產品的短路(過載電流)保護由建築物的供電系統提供,確保短路保護設備的額定電流不大於250V,20A。

### Warnung

Dieses Produkt ist darauf angewiesen, dass im Gebäude ein Kurzschluss- bzw. Überstromschutz installiert ist. Stellen Sie sicher, dass der Nennwert der Schutzvorrichtung nicht mehr als: 250 V, 20 A beträgt.

### ¡Advertencia!

Este equipo utiliza el sistema de protección contra cortocircuitos (o sobrecorrientes) del edificio. Asegúrese de que el dispositivo de protección no sea superior a: 250 V, 20 A.

### Attention

Pour ce qui est de la protection contre les courts-circuits (surtension), ce produit dépend de l'installation électrique du local. Vérifiez que le courant nominal du dispositif de protection n'est pas supérieur à :250 V, 20 A.

מוצר זה מסתמך על הגנה המותקנת במבנים למניעת קצר חשמלי. יש לוודא כי המכשיר המגן מפני הקצר החשמלי הוא לא יותר מ-250VDC, 20A

هذا المنتج يعتمد على معدات الحماية مه الدوائر القصيرة التي تم تثبيتها في المبنى  
تأكد من أن تقييم الجهاز الوقائي ليس أكثر من : 20A, 250V

### 경고!

이 제품은 전원의 단락(과전류)방지에 대해서 전적으로 건물의 관련 설비에 의존합니다. 보호장치의 정격이 반드시 250V(볼트), 20A(암페어)를 초과하지 않도록 해야 합니다.

### Waarschuwing

Dit product is afhankelijk van de kortsluitbeveiliging (overspanning) van uw elektrische installatie. Controleer of het beveiligde apparaat niet groter gedimensioneerd is dan 250V, 20A.

## Power Disconnection Warning



**Warning!** The system must be disconnected from all sources of power and the power cord removed from the power supply module(s) before accessing the chassis interior to install or remove system components.



### 電源切斷の警告

システムコンポーネントの取り付けまたは取り外しのために、シャーシ内部にアクセスするには、システムの電源はすべてのソースから切斷され、電源コードは電源モジュールから取り外す必要があります。

### 警告

在你打开机箱并安装或移除内部器件前,必须将系统完全断电,并移除电源线。

### 警告

在您打開機殼安裝或移除內部元件前，必須將系統完全斷電，並移除電源線。

### Warnung

Das System muss von allen Quellen der Energie und vom Netzanschlusskabel getrennt sein, das von den Spg.Versorgungsteilmodulen entfernt wird, bevor es auf den Chassisinnenraum zurückgreift, um Systemsbestandteile anzubringen oder zu entfernen.

### ¡Advertencia!

El sistema debe ser disconnected de todas las fuentes de energía y del cable eléctrico quitado de los módulos de fuente de alimentación antes de tener acceso el interior del chasis para instalar o para quitar componentes de sistema.

### Attention

Le système doit être débranché de toutes les sources de puissance ainsi que de son cordon d'alimentation secteur avant d'accéder à l'intérieur du chasis pour installer ou enlever des composants de système.

אזהרה מפני ניתוק חשמלי

אזהרה!

יש לנתק את המערכת מכל מקורות החשמל ויש להסיר את כבל החשמלי מהספק לפני גישה לחלק הפנימי של המארז לצורך התקנת או הסרת רכיבים.

يجب فصل انظاو من جميع مصادر انطاقت وإزانت سهك انكهرباء من وحدة امداد انطاقت قيم

انصل إلى امناطق انداخهيت نههيكم ننتبيج أو إزانت مكناث الجهاز

경고!

시스템에 부품들을 장착하거나 제거하기 위해서는 새시 내부에 접근하기 전에 반드시 전원 공급장치로부터 연결되어있는 모든 전원과 전기코드를 분리해주어야 합니다.

Waarschuwing

Voordat u toegang neemt tot het binnenwerk van de behuizing voor het installeren of verwijderen van systeem onderdelen, dient u alle spanningsbronnen en alle stroomkabels aangesloten op de voeding(en) van de behuizing te verwijderen

## Equipment Installation



**Warning!** Only trained and qualified personnel should be allowed to install, replace, or service this equipment.

機器の設置

トレーニングを受け認定された人だけがこの装置の設置、交換、またはサービスを許可されていません。

警告

只有经过培训且具有资格的人员才能进行此设备的安装、更换和维修。

警告

只有經過受訓且具資格人員才可安裝、更換與維修此設備。

Warnung

Das Installieren, Ersetzen oder Bedienen dieser Ausrüstung sollte nur geschultem, qualifiziertem Personal gestattet werden.

¡Advertencia!

Solamente el personal calificado debe instalar, reemplazar o utilizar este equipo.

**Attention**

Il est vivement recommandé de confier l'installation, le remplacement et la maintenance de ces équipements à des personnels qualifiés et expérimentés.

אזהרה!

צוות מוסמך בלבד רשאי להתקין, להחליף את הציוד או לתת שירות עבור הציוד.

والمدربيه لتزكيب واستبدال أو خدمة هذا الجهاز يجب أن يسمح فقط للمظفيه المؤهليه

경고!

훈련을 받고 공인된 기술자만이 이 장비의 설치, 교체 또는 서비스를 수행할 수 있습니다.

**Waarschuwing**

Deze apparatuur mag alleen worden geïnstalleerd, vervangen of hersteld door geschoold en gekwalificeerd personeel.

**Restricted Area**

**Warning!** This unit is intended for installation in restricted access areas. A restricted access area can be accessed only through the use of a special tool, lock and key, or other means of security. (This warning does not apply to workstations).

**アクセス制限区域**

このユニットは、アクセス制限区域に設置されることを想定しています。

アクセス制限区域は、特別なツール、鍵と錠前、その他のセキュリティの手段を用いてのみ出入りが可能です。

**警告**

此部件应安装在限制进出的场所，限制进出的场所指只能通过使用特殊工具、锁和钥匙或其它安全手段进出的场所。

**警告**

此装置仅限安装於進出管制區域，進出管制區域係指僅能以特殊工具、鎖頭及鑰匙或其他安全方式才能進入的區域。

### Warnung

Diese Einheit ist zur Installation in Bereichen mit beschränktem Zutritt vorgesehen. Der Zutritt zu derartigen Bereichen ist nur mit einem Spezialwerkzeug, Schloss und Schlüssel oder einer sonstigen Sicherheitsvorkehrung möglich.

### ¡Advertencia!

Esta unidad ha sido diseñada para instalación en áreas de acceso restringido. Sólo puede obtenerse acceso a una de estas áreas mediante la utilización de una herramienta especial, cerradura con llave u otro medio de seguridad.

### Attention

Cet appareil doit être installée dans des zones d'accès réservés. L'accès à une zone d'accès réservé n'est possible qu'en utilisant un outil spécial, un mécanisme de verrouillage et une clé, ou tout autre moyen de sécurité.

אזור עם גישה מוגבלת

אזהרה!

יש להתקין את היחידה באזורים שיש בהם הגבלת גישה. הגישה ניתנת בעזרת 'כלי אבטחה בלבד' (מפתח, מנעול וכד.).

تخصيص هذه انحدة نترك بُها ف مناطق محظورة تم .  
ممكن اننصل إن منطقت محظورة فقط من خلال استخداو أداة خاصت  
أو أ وس هُت أخري نلالأمما ققم ومفتاح

### 경고!

이 장치는 접근이 제한된 구역에 설치하도록 되어있습니다. 특수도구, 잠금 장치 및 키, 또는 기타 보안 수단을 통해서만 접근 제한 구역에 들어갈 수 있습니다.

### Waarschuwing

Dit apparaat is bedoeld voor installatie in gebieden met een beperkte toegang. Toegang tot dergelijke gebieden kunnen alleen verkregen worden door gebruik te maken van speciaal gereedschap, slot en sleutel of andere veiligheidsmaatregelen.



## Battery Handling



**Warning!** There is the danger of explosion if the battery is replaced incorrectly. Replace the battery only with the same or equivalent type recommended by the manufacturer. Dispose of used batteries according to the manufacturer's instructions

### 電池の取り扱い

電池交換が正しく行われなかった場合、破裂の危険性があります。交換する電池はメーカーが推奨する型、または同等のものを使用下さい。使用済電池は製造元の指示に従って処分して下さい。

### 警告

電池更換不當會有爆炸危險。請只使用同類電池或制造商推薦的功能相當的電池更換原有電池。請按製造商的說明處理廢舊電池。

### 警告

電池更換不當會有爆炸危險。請使用製造商建議之相同或功能相當的電池更換原有電池。請按照製造商的說明指示處理廢棄舊電池。

### Warnung

Bei Einsetzen einer falschen Batterie besteht Explosionsgefahr. Ersetzen Sie die Batterie nur durch den gleichen oder vom Hersteller empfohlenen Batterietyp. Entsorgen Sie die benutzten Batterien nach den Anweisungen des Herstellers.

### Attention

Danger d'explosion si la pile n'est pas remplacée correctement. Ne la remplacer que par une pile de type semblable ou équivalent, recommandée par le fabricant. Jeter les piles usagées conformément aux instructions du fabricant.

### ¡Advertencia!

Existe peligro de explosión si la batería se reemplaza de manera incorrecta. Reemplazar la batería exclusivamente con el mismo tipo o el equivalente recomendado por el fabricante. Desechar las baterías gastadas según las instrucciones del fabricante.

אזהרה!

קיימת סכנת פיצוץ של הסוללה במידה והוחלפה בדרך לא תקינה. יש להחליף את הסוללה בסוג התואם מחברת יצרן מומלצת. סילוק הסוללות המשומשות יש לבצע לפי הוראות היצרן.

هناك خطر من انفجار في حالة اسبدال البطارية بطريقة غير صحيحة فعلى  
اسبدال البطارية  
فقط بنفس النوع أو ما يعادلها مما أوصت به الشركة المصنعة  
جخلص من البطاريات المسحومة وفقا لعمليات الشركة الصانعة

경고!

배터리가 올바르게 교체되지 않으면 폭발의 위험이 있습니다. 기존 배터리와 동일하거나 제조사에서 권장하는 동등한 종류의 배터리로만 교체해야 합니다. 제조사의 안내에 따라 사용된 배터리를 처리하여 주십시오.

Waarschuwing

Er is ontplofingsgevaar indien de batterij verkeerd vervangen wordt. Vervang de batterij slechts met hetzelfde of een equivalent type die door de fabrikant aanbevolen wordt. Gebruikte batterijen dienen overeenkomstig fabrieksvoorschriften afgevoerd te worden.

## Redundant Power Supplies



**Warning!** This unit might have more than one power supply connection. All connections must be removed to de-energize the unit.

冗長電源装置

このユニットは複数の電源装置が接続されている場合があります。

ユニットの電源を切るためには、すべての接続を取り外さなければなりません。

警告

此部件连接的电源可能不止一个，必须将所有电源断开才能停止给该部件供电。

警告

此装置连接的电源可能不只一个，必须切断所有电源才能停止对该装置的供电。

Warnung

Dieses Gerät kann mehr als eine Stromzufuhr haben. Um sicherzustellen, dass der Einheit kein Strom zugeführt wird, müssen alle Verbindungen entfernt werden.

¡Advertencia!

Puede que esta unidad tenga más de una conexión para fuentes de alimentación. Para cortar por completo el suministro de energía, deben desconectarse todas las conexiones.

Attention

Cette unité peut avoir plus d'une connexion d'alimentation. Pour supprimer toute tension et tout courant électrique de l'unité, toutes les connexions d'alimentation doivent être débranchées.

אם קיים יותר מספק אחד

אזהרה!

ליחידה יש יותר מחיבור אחד של ספק. יש להסיר את כל החיבורים על מנת לרוקן את היחידה.

قد يكون لهذا الجهاز عدة اتصالات بوحدات امداد الطاقة .

يجب إزالة كافة الاتصالات لعسل الوحدة عن الكهرباء

경고!

이 장치에는 한 개 이상의 전원 공급 단자가 연결되어 있을 수 있습니다. 이 장치에 전원을 차단하기 위해서는 모든 연결 단자를 제거해야만 합니다.

Waarschuwing

Deze eenheid kan meer dan één stroomtoevoeraansluiting bevatten. Alle aansluitingen dienen verwijderd te worden om het apparaat stroomloos te maken.

## Backplane Voltage



**Warning!** Hazardous voltage or energy is present on the backplane when the system is operating. Use caution when servicing.

### バックプレーンの電圧

システムの稼働中は危険な電圧または電力が、バックプレーン上にかかっています。

修理する際には注意ください。

### 警告

当システム正在进行時、背板上有很危险的电压或能量、进行维修时务必小心。

### 警告

當系統正在進行時、背板上危險的電壓或能量、進行維修時務必小心。

### Warnung

Wenn das System in Betrieb ist, treten auf der Rückwandplatine gefährliche Spannungen oder Energien auf. Vorsicht bei der Wartung.

### ¡Advertencia!

Cuando el sistema está en funcionamiento, el voltaje del plano trasero es peligroso. Tenga cuidado cuando lo revise.

### Attention

Lorsque le système est en fonctionnement, des tensions électriques circulent sur le fond de panier. Prendre des précautions lors de la maintenance.

מתח בפנל האחורי

אזהרה!

קיימת סכנת מתח בפנל האחורי בזמן תפעול המערכת. יש להיזהר במהלך העבודה.

هناك خطر من التيار الكهربائي أو الطاقة المتجددة على اللوحة  
عندما يكون النظام يعمل كه حذرا عند خدمة هذا الجهاز

경고!

시스템이 동작 중일 때 후면판 (Backplane)에는 위험한 전압이나 에너지가 발생 합니다.  
서비스 작업 시 주의하십시오.

Waarschuwing

Een gevaarlijke spanning of energie is aanwezig op de backplane wanneer het systeem in gebruik is. Voorzichtigheid is geboden tijdens het onderhoud.

## Comply with Local and National Electrical Codes



**Warning!** Installation of the equipment must comply with local and national electrical codes.

地方および国の電気規格に準拠

機器の取り付けはその地方および国の電気規格に準拠する必要があります。

警告

设备安装必须符合本地与本国电气法规。

警告

設備安裝必須符合本地與本國電氣法規。

Warnung

Die Installation der Geräte muss den Sicherheitsstandards entsprechen.

¡Advertencia!

La instalación del equipo debe cumplir con las normas de electricidad locales y nacionales.

Attention

L'équipement doit être installé conformément aux normes électriques nationales et locales.

תיאום חוקי החשמל הארצי

אזהרה!

התקנת הציוד חייבת להיות תואמת לחוקי החשמל המקומיים והארציים.

تركيب المعدات الكهربائية يجب أن يمتثل للقوايه المحلية والبطية المتعلقة  
بالكهرباء

경고!

현 지역 및 국가의 전기 규정에 따라 장비를 설치해야 합니다.

Waarschuwing

Bij installatie van de apparatuur moet worden voldaan aan de lokale en nationale elektriciteitsvoorschriften.

## Product Disposal



**Warning!** Ultimate disposal of this product should be handled according to all national laws and regulations.

製品の廃棄

この製品を廃棄処分する場合、国の関係する全ての法律・条例に従い処理する必要があります。

警告

本产品的废弃处理应根据所有国家的法律和规章进行。

警告

本產品的廢棄處理應根據所有國家的法律和規章進行。

Warnung

Die Entsorgung dieses Produkts sollte gemäß allen Bestimmungen und Gesetzen des Landes erfolgen.

¡Advertencia!

Al deshacerse por completo de este producto debe seguir todas las leyes y reglamentos nacionales.

## Attention

La mise au rebut ou le recyclage de ce produit sont généralement soumis à des lois et/ou directives de respect de l'environnement. Renseignez-vous auprès de l'organisme compétent.

סילוק המוצר

אזהרה!

סילוק סופי של מוצר זה חייב להיות בהתאם להנחיות וחוקי המדינה.

التخلص النهائي من هذا المنتج ينبغي التعامل معه وفقا لجميع القوانين واللوائح الوطنية عند

## 경고!

이 제품은 해당 국가의 관련 법규 및 규정에 따라 폐기되어야 합니다.

## Waarschuwing

De uiteindelijke verwijdering van dit product dient te geschieden in overeenstemming met alle nationale wetten en reglementen.

## Hot Swap Fan Warning



**Warning!** Hazardous moving parts. Keep away from moving fan blades. The fans might still be turning when you remove the fan assembly from the chassis. Keep fingers, screwdrivers, and other objects away from the openings in the fan assembly's housing.

## ファン・ホットスワップの警告

警告!回転部品に注意。運転中は回転部(羽根)に触れないでください。シャーシから冷却ファン装置を取り外した際、ファンがまだ回転している可能性があります。ファンの開口部に、指、ドライバー、およびその他のものを近づけないで下さい。

## 警告!

警告! 危險的可移動性零件。請務必與轉動的风扇叶片保持距離。當您從機架移除風扇裝置，風扇可能仍在轉動。小心不要將手指、螺絲起子和其他物品太靠近風扇

## 警告

危險的可移動性零件。請務必與轉動的风扇叶片保持距離。當您從機架移除風扇裝置，風扇可能仍在轉動。小心不要將手指、螺絲起子和其他物品太靠近風扇。

### Warnung

Gefährlich Bewegende Teile. Von den bewegenden Lüfterblätter fern halten. Die Lüfter drehen sich u. U. noch, wenn die Lüfterbaugruppe aus dem Chassis genommen wird. Halten Sie Finger, Schraubendreher und andere Gegenstände von den Öffnungen des Lüftergehäuses entfernt.

### ¡Advertencia!

Riesgo de piezas móviles. Mantener alejado de las aspas del ventilador. Los ventiladores podran dar vuelta cuando usted quite el montaje del ventilador del chasis. Mantenga los dedos, los destornilladores y todos los objetos lejos de las aberturas del ventilador

### Attention

Pieces mobiles dangereuses. Se tenir a l'écart des lames du ventilateur Il est possible que les ventilateurs soient toujours en rotation lorsque vous retirerez le bloc ventilateur du châssis. Prenez garde à ce que doigts, tournevis et autres objets soient éloignés du logement du bloc ventilateur.

### אזהרה!

חלקים נעים מסוכנים. התרחק מלהבי המאוורר בפעולה כאשר מסירים את חלקי המאוורר מהמארז, יתכן והמאווררים עדיין עובדים. יש להרחיק למרחק בטוח את האצבעות וכלי עבודה שונים מהפתחים בתוך המאוורר

تحذير! أجزاء متحركة خطيرة. ابتعد عن شفرات المروحة المتحركة. من الممكن أن المراوح لا تزال تدور عند إزالة كتلة المروحة من الهيكل يجب إبقاء الأصابع ومفكات البراغي وغيرها من الأشياء بعيدا عن الفتحات في كتلة المروحة

### 경고!

움직이는 위험한 부품. 회전하는 송풍 날개에 접근하지 마세요. 새시로부터 팬 조립품을 제거할 때 팬은 여전히 회전하고 있을 수 있습니다. 팬 조립품 외관의 열려있는 부분들로부터 손가락 및 스크류드라이버, 다른 물체들이 가까이 하지 않도록 배치해 주십시오.

### Waarschuwing

Gevaarlijk bewegende onderdelen. Houd voldoende afstand tot de bewegende ventilatorbladen. Het is mogelijk dat de ventilator nog draait tijdens het verwijderen van het ventilatorsamenstel uit het chassis. Houd uw vingers, schroevendraaiers en eventuele andere voorwerpen uit de buurt van de openingen in de ventilatorbehuizing.



## Power Cable and AC Adapter



**Warning!** When installing the product, use the provided or designated connection cables, power cables and AC adaptors. Using any other cables and adaptors could cause a malfunction or a fire. Electrical Appliance and Material Safety Law prohibits the use of UL or CSA -certified cables (that have UL/CSA shown on the code) for any other electrical devices than products designated by Supermicro only.

### 電源コードとACアダプター

製品を設置する場合、提供または指定および購入された接続ケーブル、電源コードとACアダプターを、該当する地域の条例や安全基準に適合するコードサイズやプラグと共に使用下さい。他のケーブルやアダプタを使用すると故障や火災の原因になることがあります。

電気用品安全法は、ULまたはCSA認定のケーブル(UL/CSAマークがコードに表記)を Supermicro が指定する製品以外に使用することを禁止しています。

### 警告

安装此产品时,请使用本身提供的或指定的或采购的连接线,电源线和电源适配器。包含遵照当地法规和安全要求的合规的电源线尺寸和插头。使用其它线材或适配器可能会引起故障或火灾。除了Supermicro所指定的产品,电气用品和材料安全法律规定禁止使用未经UL或CSA认证的线材。(线材上会显示UL/CSA符号)。

### 警告

安裝此產品時,請使用本身提供的或指定的或採購的連接線,電源線和電源適配器。包含遵照當地法規和安全要求的合規的電源線尺寸和插頭。使用其它線材或適配器可能會引起故障或火災。除了Supermicro所指定的產品,電氣用品和材料安全法律規定禁止使用未經UL或CSA認證的線材。(線材上會顯示UL/CSA符號)。

### Warnung

Nutzen Sie beim Installieren des Produkts ausschließlich die von uns zur Verfügung gestellten Verbindungskabeln, Stromkabeln und/oder Adapter, die Ihre örtlichen Sicherheitsstandards einhalten. Der Gebrauch von anderen Kabeln und Adapter können Fehlfunktionen oder Feuer verursachen. Die Richtlinien untersagen das Nutzen von UL oder CAS zertifizierten Kabeln (mit UL/CSA gekennzeichnet), an Geräten oder Produkten die nicht mit Supermicro gekennzeichnet sind.

### ¡Advertencia!

Cuando instale el producto, utilice la conexión provista o designada o procure cables, Cables de alimentación y adaptadores de CA que cumplan con los códigos locales y los requisitos de seguridad, incluyendo el tamaño adecuado del cable y el enchufe. El uso de otros cables y adaptadores podría causar un mal funcionamiento o un incendio. La Ley de Seguridad de Aparatos Eléctricos y de Materiales prohíbe El uso de cables certificados por UL o CSA (que tienen el certificado UL / CSA en el código) para cualquier otros dispositivos eléctricos que los productos designados únicamente por Supermicro.

### Attention

Lors de l'installation du produit, utilisez les cables de connection fournis ou désigné ou achetez des cables, cables de puissance et adaptateurs respectant les normes locales et les conditions de securite y compris les tailles de cables et les prises electriques appropries. L'utilisation d'autres cables et adaptateurs peut provoquer un dysfonctionnement ou un incendie. Appareils électroménagers et la Loi sur la Sécurité Matériel interdit l'utilisation de câbles certifiés- UL ou CSA (qui ont UL ou CSA indiqué sur le code) pour tous les autres appareils électriques sauf les produits désignés par Supermicro seulement.

AC ימאתמו מיילמשח מילבכ

!הרהזא

ךרוצל ומאתוה וא ושכרנ רשא AC מימאתמו מיקפס, מילבכב שמתשהל שי, רצומה תא מיניקתמ רשאכ לכב שומיש . עקתהו לבכה לש הנוכח הדימ ללוכ, תוימוקמה תוחיטבה תושירדל ומאתוה רשאו, הנקתהה למשחה ירישכמב שומישה יקוחל מאתהב. ילמשח רצק וא הלקתל מורגל לולע, רחא גוסמ מאתמ וא לבכ לש דוק מהילע עיפומ רשאכ) UL-ב או CSA-ב-ב מיכמסומה מילבכב שמתשהל רוסיא מייק, תוחיטבה יקוחו דבלב Supermicro י"ע מאתוה רשא רצומב קר אלא, רחא ילמשח רצומ לכ רובע (UL/CSA)

תאלבאלא אארשב מץ וא אדדחמלא וא ארפוטמלא תאלויסוולא מאדחטסאב מץ, אגתנמלא בייקרת דנע לכלז יפ אב אילחמלא אלאסלא תאבלטתמו נינאווקב מאזתלאלא אג דדרתמלא ראיטלא תאלוחמו אילברמלא אילי. וא לטע יפ בבסטטי דץ אירחא תאלוחמו תאלבאלא יא מאדחטסא. מילסלא סבאלאו לטוולא מץ א. UL וא CSA לביק נמ אדמאמלא תאלבאלא מאדחטסא תאדעמלא אילברמלא אזהאלל אלאסלא נונאק רזחי Supermicro לביק נמ אדדחמלא אילינעמלא תאגתנמלא רייג אירחא תאדעמ יא אג (UL/CSA) אלאע למחתי אילאו

### 전원 케이블 및 AC 어댑터

경고! 제품을 설치할 때 현지 코드 및 적절한 굵기의 코드와 플러그를 포함한 안전 요구 사항을 준수하여 제공되거나 지정된 연결 혹은 구매 케이블, 전원 케이블 및 AC 어댑터를 사용하십시오.

다른 케이블이나 어댑터를 사용하면 오작동이나 화재가 발생할 수 있습니다. 전기 용품 안전법은 UL 또는 CSA 인증 케이블 (코드에 UL / CSA가 표시된 케이블)을 Supermicro 가 지정한 제품 이외의 전기 장치에 사용하는 것을 금지합니다.

### Stroomkabel en AC-Adapter

Waarschuwing! Bij het aansluiten van het Product uitsluitend gebruik maken van de geleverde Kabels of een andere geschikte aan te schaffen Aansluitmethode, deze moet altijd voldoen aan de lokale voorschriften en veiligheidsnormen, inclusief de juiste kabeldikte en stekker. Het gebruik van niet geschikte Kabels en/of Adapters kan een storing of brand veroorzaken. Wetgeving voor Elektrische apparatuur en Materiaalveiligheid verbied het gebruik van UL of CSA -gecertificeerde Kabels (met UL/CSA in de code) voor elke andere toepassing dan de door Supermicro hiervoor beoogde Producten.

# Appendix B

## System Specifications

### Drive Bays

Thirty-two 2.5" NVMe SSDs in hot-swap drive carriers

### PCI Expansion Slots

Two PCIe 3.0 x16 slots

Four External PCIe 3.0 x16 ports

### Controller Board

BPN-NVME3-136PL-J

### Chassis

136TS-R1K04JP-U2; 1U Rackmount, (WxHxD) 17.26 x 1.71 x 31.95 in. (438.4 x 43.6 x 811.7 mm)

### System Cooling

Eight 4-cm fans

### Power Supply

Model: PWS-1K04A-1R

AC Input Voltages: 100-240 VAC

Rated Input Current: 15-12A (100-127VAC) / 825-7A (200-240VAC)

Rated Input Frequency: 50-60 Hz

Rated Output Power: 1000W

Rated Output Voltages: +12V (83A at 100-127VAC, 100A at 200-240VAC), +5Vsb (4A)

### Operating Environment

Operating Temperature: 10° to 35° C (50° to 95° F)

Non-operating Temperature: -40° to 60° C (-40° to 140° F)

Operating Relative Humidity: 8% to 90% (non-condensing)

Non-operating Relative Humidity: 5% to 95% (non-condensing)

### Regulatory Compliance

FCC, ICES, CE, VCCI, RCM, UKCA, NRTL, CB

**Applied Directives, Standards**

EMC/EMI: 2014/30/EU (EMC Directive)

FCC Part 15 Subpart B

ICES-003

VCCI-CISPR 32

AS/NZS CISPR 32

EN/BS EN55024

EN/BS EN55032

EN/BS 61000-3-2

EN/BS 61000-3-3

EN/BS 61000-4-2

EN/BS 61000-4-3

EN/BS 61000-4-4

EN/BS 61000-4-5

EN/BS 61000-4-6

EN/BS 61000-4-8

EN/BS 61000-4-11

Green Environment:

2011/65/EU (RoHS Directive)

EC 1907/2006 (REACH)

2012/19/EU (WEEE Directive)

Product Safety: 2014/35/EU (LVD Directive)

UL/CSA 60950-1 (USA and Canada)

IEC/EN 60950-1

**Perchlorate Warning**

California Best Management Practices Regulations for Perchlorate Materials: This Perchlorate warning applies only to products containing CR (Manganese Dioxide) Lithium coin cells. "Perchlorate Material-special handling may apply. See [www.dtsc.ca.gov/hazardouswaste/perchlorate](http://www.dtsc.ca.gov/hazardouswaste/perchlorate)"

この装置は、クラスA機器です。この装置を住宅環境で使用すると電波妨害を引き起こすことがあります。この場合には使用者が適切な対策を講ずるよう要求されることがあります。

VCCI — A

# Appendix C

## Drive Assignment

### C.1 Overview

After installing the SSG-136R-N32JBF system, you must assign drives to hosts. This appendix provides information about drive mappings and procedures for reassigning drives to different hosts. Refer to the Web GUI or command line interface sections in this appendix for your preferred procedure.

Physical hosts are represented by "zones" and physical drives are represented by "endpoints." Familiarity with zones and endpoints is necessary to properly assign drives to hosts. Refer to the following diagrams for zone-to-host labeling, and refer to Section C.2 for information about endpoints.

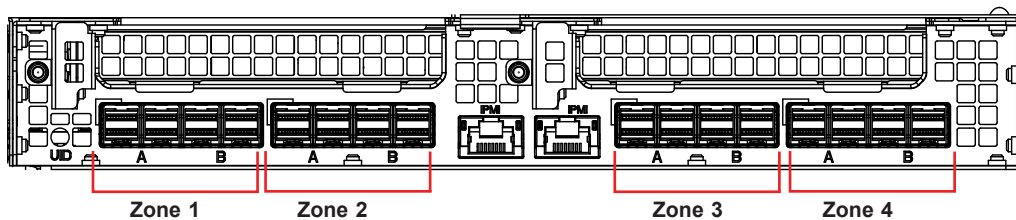

Figure C-1. Zone Labeling (Four Hosts)

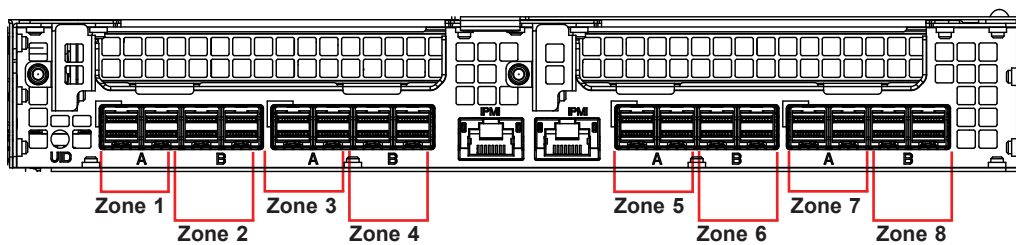

Figure C-2. Zone Labeling (Eight Hosts)

You can assign a drive to a new host by mapping the drive's endpoint to a different zone. You can do this from the Web GUI or the command line interface. Refer to your preferred procedure in Section C.3 or Section C.4.

## C.2 Drive Slots Endpoint Mapping

Each physical drive is assigned an "endpoint" number that is different from the physical slot number. The following tables provide an overview of endpoint mapping for drive slots in a four-host and eight-host configuration.

When assigning drives to hosts, start with the drives located closest to the front of the system and work your way back. Also, alternate between sleds so that the drives used by each host are spread between both sleds.

The "Slot #" column refers to the physical slot number of an NVMe SSD. The "Endpoint" column refers to the endpoint number assigned to the drive. The "Load Order" column is the recommended sequence in which drives should be assigned to hosts (i.e. assign Load Order 1 first, Load Order 2 second, etc.).

Drive Slots to Endpoint Mapping (Four Hosts)					
Tray 1			Tray 2		
Slot #	Endpoint	Load Order	Slot #	Endpoint	Load Order
0	30	25	16	14	26
1	29	27	17	13	28
2	32	17	18	16	18
3	31	19	19	15	20
4	34	9	20	18	10
5	33	11	21	17	12
6	36	1	22	20	2
7	35	3	23	19	4
8	28	5	24	12	6
9	27	7	25	11	8
10	26	13	26	10	14
11	25	15	27	9	16
12	24	21	28	8	22
13	23	23	29	7	24
14	22	29	30	6	30
15	21	31	31	5	32

Drive Slots to Endpoint Mapping (Eight Hosts)					
Tray 1			Tray 2		
Slot #	Endpoint	Load Order	Slot #	Endpoint	Load Order
0	34	25	16	18	26
1	33	27	17	17	28
2	36	17	18	20	18
3	35	19	19	19	20
4	38	9	20	22	10
5	37	11	21	21	12
6	40	1	22	24	2
7	39	3	23	23	4
8	32	5	24	16	6
9	31	7	25	15	8
10	30	13	26	14	14
11	29	15	27	13	16
12	28	21	28	12	22
13	27	23	29	11	24
14	26	29	30	10	30
15	25	31	31	9	32

## C.3 Assigning a Drive from the GUI

Drive assignment from the Web GUI requires a computer with access to the network that contains your SSG-136R-N32JBF system.

When assigning drives to hosts, start with the drives located closest to the front of the system and work your way back. Also, alternate between sleds so that the drives used by each host are spread between both sleds.

### Assigning a Drive

1. Access the Web GUI by opening a Web browser and directing it to the IP address of the SSG-136R-N32JBF system. To get the IP address of your system, refer to Section C.5.

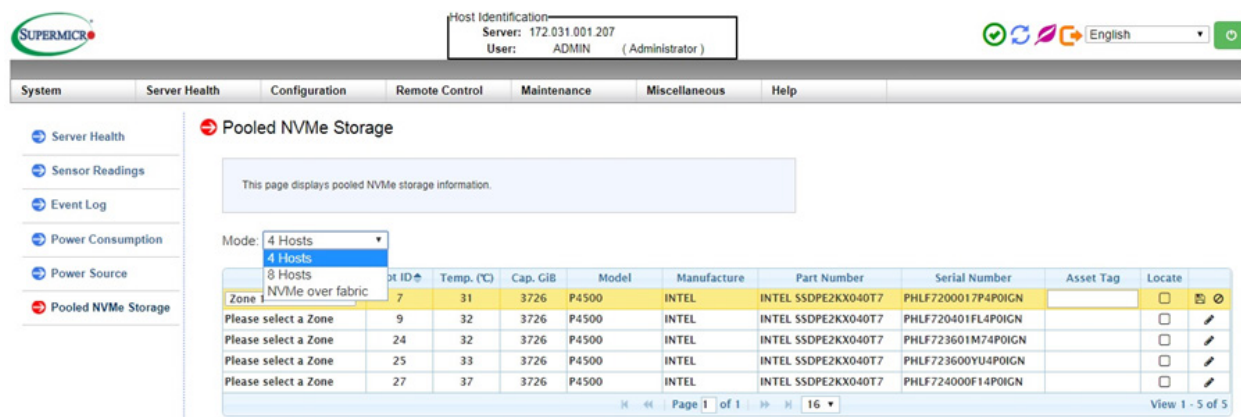

2. Log in and click on the Pooled NVMe Storage tab.
3. In the Mode field, click the drop-down bar and select "4 Hosts" or "8 Hosts" depending on your configuration.
4. On the displayed table, find a specified drive by looking at the Slot ID column.
5. Click the drop-down bar in the Zone column, then select the zone to which you want to assign this drive.

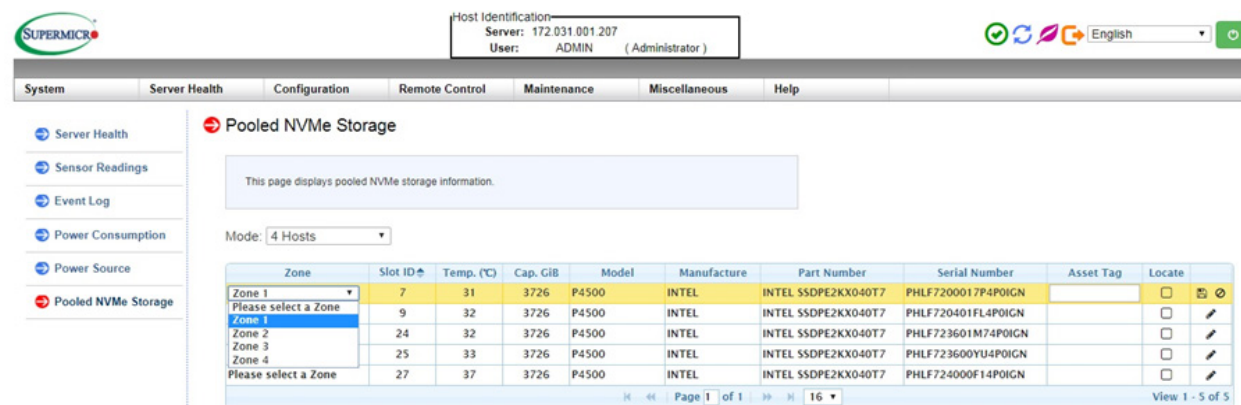

6. When finished, click the disk icon on the far right of the row to save changes, or click the cancel icon to discard changes.



## C.4 Assigning a Drive from the CLI

Drive assignment from the CLI requires Curl and Python with the json.tools module installed in a Linux environment. (Recommended versions: Curl 7.35.0 or later, Python 2.7.6 or later).

When assigning drives to hosts, start with the drives located closest to the front of the system and work your way back. Also, alternate between sleds so that the drives used by each host are spread between both sleds.

### ***Getting Drive Information***

1. Access a command line interface connected to the SSG-136R-N32JBF system.
2. To get drive information for a given zone, run the following command:

```
$ curl -k --user ADMIN:ADMIN -X GET https://<IP Address>/redfish/  
v1/Fabrics/1/Zones/1 | python -m json.tool
```

For <IP Address> use the IP address of the system (see Section C.5). For "Zones/1" replace "1" with the zone number corresponding to the host for which you are getting drive information.

In the output (see next page for example), the first item listed under "Endpoints" is the zone number, and subsequent items are drive endpoint numbers.

In the following example, endpoint 19 (drive 23) represents the only drive assigned to zone 1:

```
{
  "@odata.context": "/redfish/v1/$metadata#Zone.Zone",
  "@odata.id": "/redfish/v1/Fabrics/1/Zones/1",
  "@odata.type": "#Zone.Zone",
  "Description": "PCIe Zone 1",
  "Id": "1",
  "Links": {
    "Endpoints": [
      {
        "@odata.id": "/redfish/v1/Fabrics/1/Endpoints/1"
      },
      {
        "@odata.id": "/redfish/v1/Fabrics/1/Endpoints/19"
      }
    ],
    "InvolvedSwitches": [
      {
        "@odata.id": "/redfish/v1/Fabrics/1/Switches/1"
      }
    ]
  },
  "Name": "Zone",
  "Oem": {},
  "Status": {
    "Health": "OK",
    "State": "Disabled"
  }
}
```

For information about which endpoints correspond to physical drives, refer to Section C.2.

### Reassigning a Drive

1. To change drive assignment, you must first create a .txt file that includes your changes in JSON format. For example:

```

{
  "Endpoints": [
    {
      "@odata.id": "/redfish/v1/Fabrics/1/Endpoints/1"
    },
    {
      "@odata.id": "/redfish/v1/Fabrics/1/Endpoints/7"
    },
    {
      "@odata.id": "/redfish/v1/Fabrics/1/Endpoints/5"
    }
  ]
}

```

In the above example, endpoint 19 (drive 23) was removed from zone 1, and endpoints 7 and 5 (drives 29 and 31) were added to zone 1.

2. In the command line interface, run the following command:

```

$ curl -k --http1.0 --user ADMIN:ADMIN -X PATCH -d @<text.txt>
  https://<IP Address>/redfish/v1/Fabrics/1/Zones/1

```

For <IP Address>, use the IP address of the system (see Section C.5). For <text.txt>, use the file name of the text file you saved. For "Zones/1" replace "1" with the zone number corresponding to the host on which you are making drive assignment changes.

The following output indicates success:

```

{"Success":{"code":"Base.1.0.0.Success","Message":"Successfully
Completed Request."}}

```

3. To verify your changes, perform the "Getting Drive Information" procedure.

## C.5 Obtaining the System IP Address

Drive reassignment requires the IP address of the SSG-136R-N32JBF system. Perform the following procedure to obtain the system IP address.

If DHCP is detected, a dynamic IP address is assigned to the system. If DHCP is not detected, the default IP address is 192.168.1.99.

### ***Obtaining System IP Address***

1. Get the MAC address of the SSG-136R-N32JBF. The MAC address is printed on the service tags on the front end of the chassis under the control panels.
2. Consult your network administrator to determine IP address from a MAC address. This IP address is required to access the access the Web GUI and to run CLI commands.

# Appendix D

## Firmware Updates

### D.1 Updating Switch Configuration

Use IPMI to update the configuration of the JBOF switches.

1. Log into the IPMI.

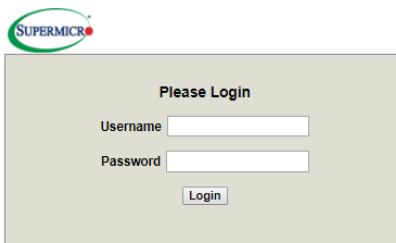

The image shows the Supermicro IPMI login interface. At the top left is the Supermicro logo. Below it is a box titled "Please Login" containing two input fields: "Username" and "Password", followed by a "Login" button.

The default Username and Password are ADMIN / ADMIN.

2. Under the Maintenance tab, select **JBOF FW Update**.

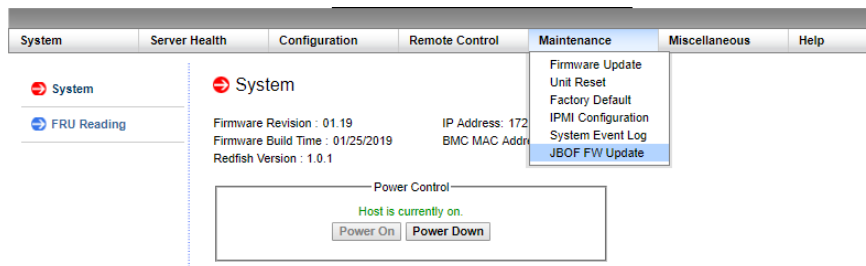

The image shows the IPMI web interface with the "Maintenance" tab selected. A dropdown menu is open, showing options: "Firmware Update", "Unit Reset", "Factory Default", "IPMI Configuration", "System Event Log", and "JBOF FW Update". The "JBOF FW Update" option is highlighted. The main content area shows system information like "Firmware Revision : 01.19" and "IP Address: 172...".

3. Select the targeted switch and click the **Update** button.

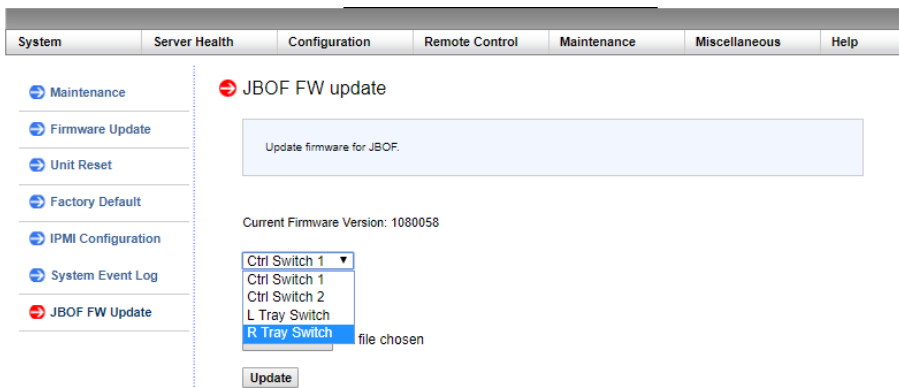

The image shows the "JBOF FW update" page in the IPMI interface. The "Maintenance" tab is active, and the "JBOF FW update" option is selected in the left sidebar. The main content area displays "Update firmware for JBOF." and "Current Firmware Version: 1080058". A dropdown menu is open, showing options: "Ctrl Switch 1", "Ctrl Switch 1", "Ctrl Switch 2", "L Tray Switch", and "R Tray Switch". The "R Tray Switch" option is highlighted, and the text "file chosen" is visible below it. An "Update" button is at the bottom.

- Click **Choose File** to select configuration file, and click the **Update** button.

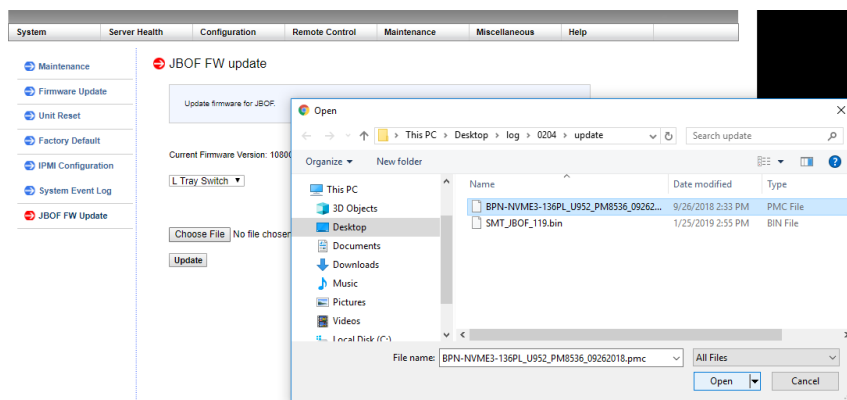

- Click **OK** to confirm.

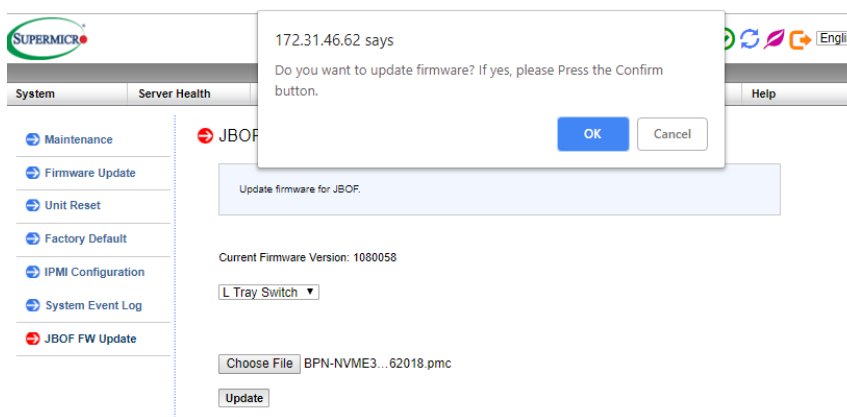

- Click **OK** to finish.

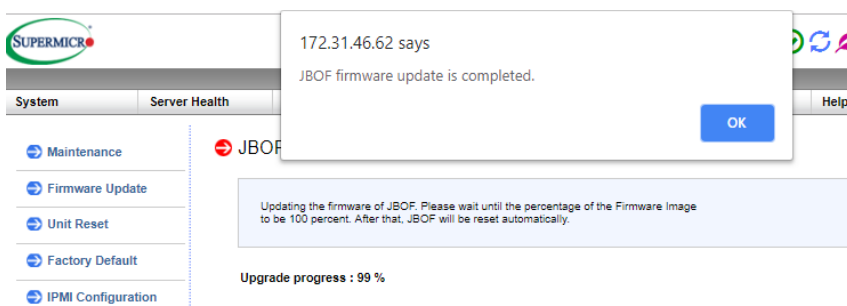

- After all intended switches are configured, please reset the system to complete the update.

## D.2 Updating the BMC Firmware

Use IPMI to update the BMC firmware.

1. Log into the IPMI.

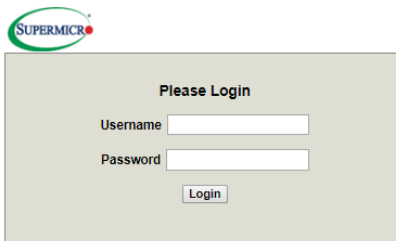

By default, both Username and Password are ADMIN

2. Under the Maintenance tab, select **Firmware Update**.

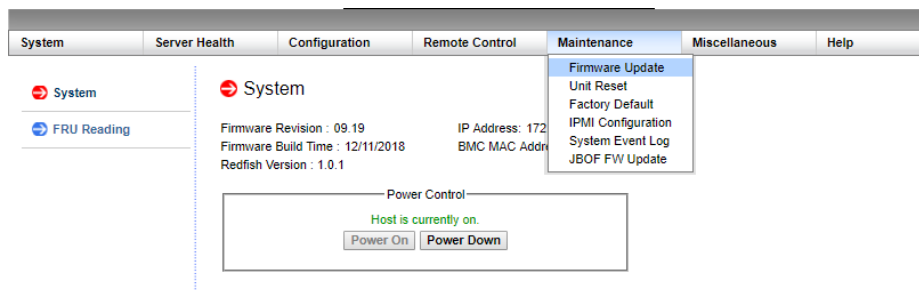

3. Click the **Enter Update Mode** button.

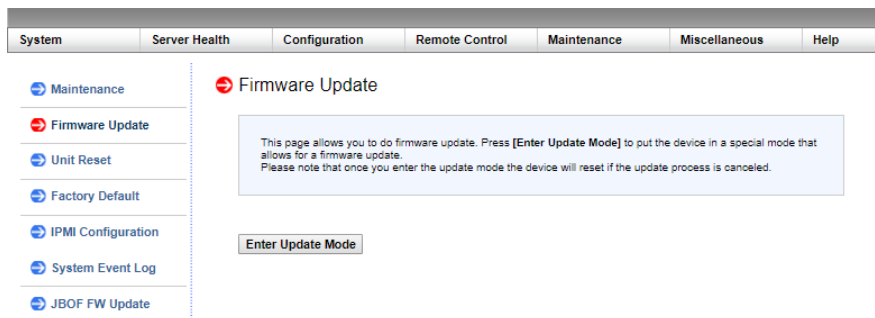

Read the caution message and click **OK**.

4. Click **Choose File**, select the configuration file, then click the **Upload Firmware** button.

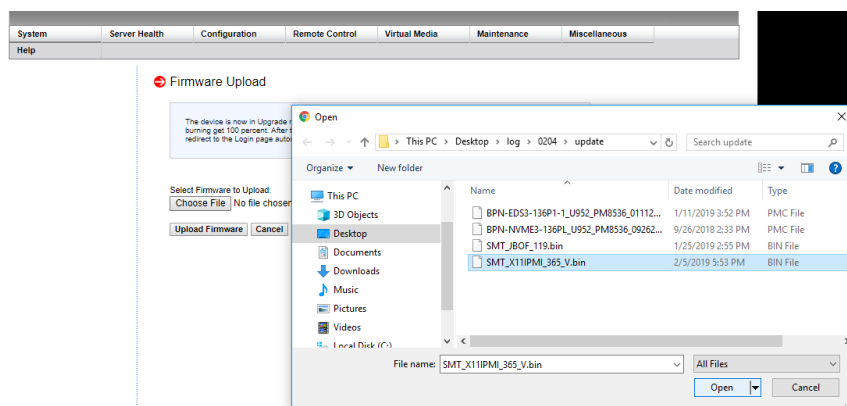

5. Clear all check box options and click the **Start Upgrade** button.

Module Name	Existing Version	New Version
IPMI_FW	09.19	01.19

Preserve Configuration (Unchecking this option will restore the BMC's factory default setting.)  
 Preserve SDR (Unchecking this option will restore the SDR defaults.)  
 Preserve SSL certificate (Unchecking this option will restore the default SSL certificate.)

Start Upgrade Cancel

6. Click **OK** to confirm and wait.

172.31.36.153 says  
Upgrade complete: Please wait for 1 minute

OK

The device is now in upgrade mode. Please wait until the percentage of the Firmware Image burning reaches 100 percent. After that, please wait for the system to reboot. The web page will redirect to the Login page automatically.

Upgrade progress : 100%

The JBOF system reboots to complete the update.