

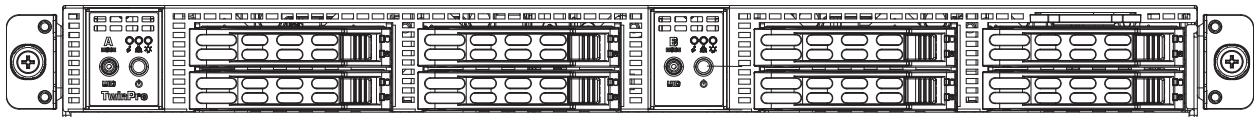

TwinPro™
1029TP-DTR
1029TP-DC0R
1029TP-DC1R



USER'S MANUAL

Revision 1.0d

The information in this User's Manual has been carefully reviewed and is believed to be accurate. The vendor assumes no responsibility for any inaccuracies that may be contained in this document, and makes no commitment to update or to keep current the information in this manual, or to notify any person or organization of the updates. **Please Note: For the most up-to-date version of this manual, please see our website at www.supermicro.com.**

Super Micro Computer, Inc. ("Supermicro") reserves the right to make changes to the product described in this manual at any time and without notice. This product, including software and documentation, is the property of Supermicro and/or its licensors, and is supplied only under a license. Any use or reproduction of this product is not allowed, except as expressly permitted by the terms of said license.

IN NO EVENT WILL Super Micro Computer, Inc. BE LIABLE FOR DIRECT, INDIRECT, SPECIAL, INCIDENTAL, SPECULATIVE OR CONSEQUENTIAL DAMAGES ARISING FROM THE USE OR INABILITY TO USE THIS PRODUCT OR DOCUMENTATION, EVEN IF ADVISED OF THE POSSIBILITY OF SUCH DAMAGES. IN PARTICULAR, SUPER MICRO COMPUTER, INC. SHALL NOT HAVE LIABILITY FOR ANY HARDWARE, SOFTWARE, OR DATA STORED OR USED WITH THE PRODUCT, INCLUDING THE COSTS OF REPAIRING, REPLACING, INTEGRATING, INSTALLING OR RECOVERING SUCH HARDWARE, SOFTWARE, OR DATA.

Any disputes arising between manufacturer and customer shall be governed by the laws of Santa Clara County in the State of California, USA. The State of California, County of Santa Clara shall be the exclusive venue for the resolution of any such disputes. Supermicro's total liability for all claims will not exceed the price paid for the hardware product.

FCC Statement: This equipment has been tested and found to comply with the limits for a Class A digital device pursuant to Part 15 of the FCC Rules. These limits are designed to provide reasonable protection against harmful interference when the equipment is operated in a commercial environment. This equipment generates, uses, and can radiate radio frequency energy and, if not installed and used in accordance with the manufacturer's instruction manual, may cause harmful interference with radio communications. Operation of this equipment in a residential area is likely to cause harmful interference, in which case you will be required to correct the interference at your own expense.

California Best Management Practices Regulations for Perchlorate Materials: This Perchlorate warning applies only to products containing CR (Manganese Dioxide) Lithium coin cells. "Perchlorate Material-special handling may apply. See www.dtsc.ca.gov/hazardouswaste/perchlorate".



WARNING: This product can expose you to chemicals including lead, known to the State of California to cause cancer and birth defects or other reproductive harm. For more information, go to www.P65Warnings.ca.gov.

The products sold by Supermicro are not intended for and will not be used in life support systems, medical equipment, nuclear facilities or systems, aircraft, aircraft devices, aircraft/emergency communication devices or other critical systems whose failure to perform be reasonably expected to result in significant injury or loss of life or catastrophic property damage. Accordingly, Supermicro disclaims any and all liability, and should buyer use or sell such products for use in such ultra-hazardous applications, it does so entirely at its own risk. Furthermore, buyer agrees to fully indemnify, defend and hold Supermicro harmless for and against any and all claims, demands, actions, litigation, and proceedings of any kind arising out of or related to such ultra-hazardous use or sale.

Manual Revision 1.0d

Release Date: June 08, 2020

Unless you request and receive written permission from Super Micro Computer, Inc., you may not copy any part of this document. Information in this document is subject to change without notice. Other products and companies referred to herein are trademarks or registered trademarks of their respective companies or mark holders.

Copyright © 2020 by Super Micro Computer, Inc.
All rights reserved.

Printed in the United States of America

Preface

About this Manual

This manual is written for professional system integrators and PC technicians. It provides information for the installation and use of the SuperServer 1029TP-DTR/DC0R/DC1R. Installation and maintenance should be performed by experienced technicians only.

The TwinPro 1029TP-DTR/DC0R/DC1R is a high-end server based on the SC809H-R1K05P3 1U rackmount chassis and the X11DPT-PS dual processor serverboard. All models have an IPMI LAN port, two motherboard nodes and four hot-swap 2.5" Hard Disk Drives (HDD) per node.

Each of the various models of the TwinPro 1029TP-DTR/DC0R/DC1R servers have different backplanes as listed in the table below:

TwinPro 1029TP-DTR/DC0R/DC1R Model Variations	
Server Model	Node Backplane
1029TP-DTR	BPN-ADP-6SATA3P
1029TP-DC0R	BPN-ADP-S3008L-L6IP
1029TP-DC1R	BPN-ADP-S3108L-H6IRP

Please refer to the 1029TP-DTR/DC0R/DC1R server specifications page on our website for updates on supported memory, processors and operating systems (<http://www.supermicro.com>).

Notes

For your system to work properly, please follow the links below to download all necessary drivers/utilities and the user's manual for your server.

- Supermicro product manuals: <http://www.supermicro.com/support/manuals/>
- Product drivers and utilities: <https://www.supermicro.com/wftp/>
- Product safety info: http://www.supermicro.com/about/policies/safety_information.cfm

If you have any questions, please contact our support team at: support@supermicro.com

This manual may be periodically updated without notice. Please check the Supermicro website for possible updates to the manual revision level.

Secure Data Deletion

A secure data deletion tool designed to fully erase all data from storage devices can be found on our website: https://www.supermicro.com/about/policies/disclaimer.cfm?url=/wftp/utility/Log9_Secure_Data_Deletion_Utility/

Warnings

Special attention should be given to the following symbols used in this manual.



Warning! Indicates important information given to prevent equipment/property damage or personal injury.



Warning! Indicates high voltage may be encountered when performing a procedure.

Contents

Chapter 1 Introduction

1.1 Overview.....	9
1.2 Unpacking the System	9
1.3 System Features	10
1.4 Server Chassis Features.....	11
Control Panel	11
Front Features.....	12
Rear Features	12
1.5 Motherboard Layout	13
Quick Reference Table.....	14

Chapter 2 Server Installation

2.1 Overview.....	16
2.2 Preparing for Setup.....	16
Choosing a Setup Location.....	16
Rack Precautions	16
Server Precautions.....	17
Rack Mounting Considerations	17
Ambient Operating Temperature.....	17
Airflow	17
Mechanical Loading.....	17
Circuit Overloading	17
Reliable Ground.....	18
2.3 Installing the System into a Rack	19
Identifying the Rails	19
Assembling the Outer Rails	20
Installing the Outer Rails onto the Rack	21
Sliding the Chassis onto the Rack Rails.....	22

Chapter 3 Maintenance and Component Installation

3.1 Removing Power	23
3.2 Accessing the System.....	23
3.3 Motherboard Components.....	26

Processor and Heatsink Installation.....	26
The Xeon Series Processor	26
Assembling the Processor Package.....	27
Removing the Dust Cover from the CPU Socket.....	30
Installing the Processor Heatsink Module (PHM)	31
Removing the Processor Heatsink Module from the Motherboard.....	32
Memory Installation	33
ESD Precautions.....	33
Precautions	33
Introduction to Intel® Optane DC Persistent Memory	33
Memory Support	33
Memory Installation Sequence	34
General Memory Population Requirements	35
DIMM Population Guidelines for Optimal Performance	35
DIMM Installation	37
DIMM Module Removal.....	37
PCI Expansion Card Installation	38
Motherboard Battery	38
3.4 Chassis Components	39
Installing Hard Drives	39
Air Shroud.....	42
Installing an Adapter Card.....	43
Installing the Riser Card	44
SIOM Modules	46
System Fans	48
Power Supply	49
Chapter 4 Motherboard Connections	
4.1 Power Connections	51
4.2 Headers and Connectors	51
4.3 Ports	53
4.4 Jumpers.....	56
Explanation of Jumpers.....	56
4.5 LED Indicators.....	58

Chapter 5 Software

5.1 Microsoft Windows OS Installation.....	59
5.2 Driver Installation.....	61
5.3 SuperDoctor® 5.....	62
5.4 IPMI	62

Chapter 6 UEFI BIOS

6.1 Introduction.....	63
Starting the Setup Utility	63
6.2 Main Setup	64
6.3 Advanced Setup Configurations.....	65
6.4 Event Logs	92
6.5 IPMI	94
6.6 Security Settings	97
6.7 Boot Settings.....	100
6.8 Save & Exit.....	103

Appendix A BIOS Codes**Appendix B Standardized Warning Statements for AC Systems****Appendix C System Specifications****Appendix D UEFI BIOS Recovery**

Contacting Supermicro

Headquarters

Address: Super Micro Computer, Inc.
980 Rock Ave.
San Jose, CA 95131 U.S.A.

Tel: +1 (408) 503-8000

Fax: +1 (408) 503-8008

Email: marketing@supermicro.com (General Information)
support@supermicro.com (Technical Support)

Website: www.supermicro.com

Europe

Address: Super Micro Computer B.V.
Het Sterrenbeeld 28, 5215 ML
's-Hertogenbosch, The Netherlands

Tel: +31 (0) 73-6400390

Fax: +31 (0) 73-6416525

Email: sales@supermicro.nl (General Information)
support@supermicro.nl (Technical Support)
rma@supermicro.nl (Customer Support)

Website: www.supermicro.nl

Asia-Pacific

Address: Super Micro Computer, Inc.
3F, No. 150, Jian 1st Rd.
Zhonghe Dist., New Taipei City 235
Taiwan (R.O.C)

Tel: +886-(2) 8226-3990

Fax: +886-(2) 8226-3992

Email: support@supermicro.com.tw

Website: www.supermicro.com.tw

Chapter 1

Introduction

1.1 Overview

This chapter provides a brief outline of the functions and features of the 1029TP-DTR/DC0R/DC1R. The 1029TP-DTR/DC0R/DC1R is based on the X11DPT-PS motherboard and the SC809H-R1K05P3 chassis.

In addition to the motherboard and chassis, several important parts that are included with the system are listed below.

Main Parts List		
Description	Part Number	Quantity
Twinpro X11 air shroud	MCP-310-21716-0B	2 per node
Backplane adapter card with 6 SATA ports (1029TP-DTR only)	BPN-ADP-6SATA3P	2 per node
Backplane adapter card for LSI 3008, SAS 12Gbs, with six ports inside (1029TP-DC0R only)	BPN-ADP-S3008L-L6IP	2 per node
Backplane adapter card for LSI 3108, SAS 12Gbps, with six ports internal (1029TP-DC1R only)	BPN-ADP-S3108L-H6IRP	2 per node
1U 8-port 2-node 12-Gbps backplane for 4x2.5" SAS3/SATA3 HDD/SSD	BPN-SAS3-809H	1 per node
Black gen 3 hot-swap 2.5-inch HDD tray	MCP-220-00047-0B	8 (4 per node)
40x40x56 mm, 20.5K-17.6K RPM, counter-rotating fan for 1U Twin Pro series servers	FAN-0167L4	3 per node
1U passive CPU heat sink with a narrow retention mechanism	SNK-P0067PS	2 per node
1U passive CPU heat sink with a 26-mm wide middle air channel with a narrow retention mechanism	SNK-P0067PSM	2 per node
1U LHS TwinPro riser card with one PCI-E x16 slot	RSC-P-6	2 per node
1U RHS TwinPro riser card with one PCI-E x16 slot	RSC-R1UTP-E16R	2 per node
Outer rail (quick) for 1U 17.2"W chassis	MCP-290-00102-0N	1 set
26" Inner rail, front, quick-release type	MCP-290-00130-0N	1 set

1.2 Unpacking the System

Inspect the box the SuperServer 1029TP-DTR/DC0R/DC1R was shipped in and note if it was damaged in any way. If any equipment appears damaged, please file a damage claim with the carrier who delivered it.

Decide on a suitable location for the rack unit that will hold the server. It should be situated in a clean, dust-free area that is well ventilated. Avoid areas where heat, electrical noise and electromagnetic fields are generated. It will also require a grounded AC power outlet nearby. Be sure to read the precautions and considerations noted in Appendix B.

1.3 System Features

The following table provides you with an overview of the main features of the 1029TP-DTR/DC0R/DC1R. Please refer to Appendix C for additional specifications.

System Features
Motherboard
X11DPT-PS
Chassis
SC809H-R1K05P3
CPU
Dual Intel® Xeon 81xx/61xx/51xx/41xx/31xx and 82xx/62xx/52xx/42xx/32xx series processors; each processor supports UPI 10.4 GT/s Note: Both CPUs need to be installed for full access to the PCI-E slots, DIMM slots, and onboard controllers. Refer to the block diagram on page 15 to determine which slots or devices may be affected. Note: The 1029TP-DTR/DC0R/DC1R system does not support Omni-Path Fabric CPUs.
Socket Type
Socket P0
Memory
Integrated memory controller supports up to 2 TB of Load Reduced DIMM (LRDIMM), Registered DIMM (RDIMM), Non-Volatile DIMM (NV-DIMM) DDR4 (288-pin) ECC 2933/2666/2400/2133/1866/1600/1333 MHz modules in 16 slots at up to 128GB at 1.2V. Note 1: Memory speed support depends on the processors used in the system. Note 2: For the latest CPU/memory updates, please refer to our website at http://www.supernmicro.com/products/motherboard .
Chipset
Intel C621 chipset
Expansion Slots
The following PCI-E slots are available on the serverboard: One PCI-Express 3.0 x8 slot supported by CPU1 (SXB1) One PCI-Express 3.0 x16 slot supported by CPU2 (SXB2) One PCI-Express 3.0 x16 slot supported by CPU1 (SXB3_1) One PCI-Express 3.0 x8 slot supported by CPU2 (SXB3_2) One PCI-E 3.0 x16 slot supported by CPU2 (SXB4)
Hard Drives
Up to eight 2.5" HDDs (four per node)
Power
1000 Watt
Dimensions
(WxHxD) 17.2 x 1.75 x 28.25 in. (437 x 45 x 718 mm)

1.4 Server Chassis Features

Control Panel

The switches and LEDs located on the control panel are described below. See Chapter 4 for details on the control panel connections.

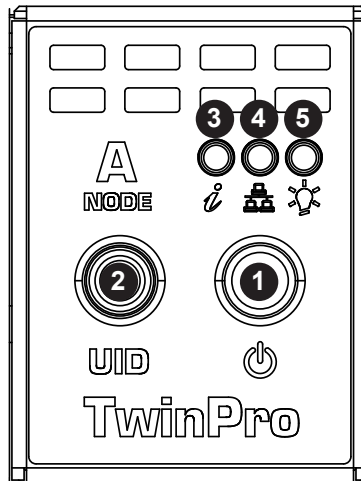

Figure 1-1. Control Panel View

Control Panel Features		
Item	Feature	Description
1	Power Button	The main power button on each of the control panels is used to apply or remove power from the power supply to associated node Turning power to the system off with this button removes the main power, but keeps standby power supplied to the system. The power button has a built-in LED which will turn green when the power is on
2	UID Button	When used with a UID compatible motherboard, the UID button is used to turn on or off the blue light function of the LED. This light is displayed in the front as part of the UID button and with a separate LED at the rear of the node. The light helps locate the node in large racks and server banks.
3	Information LED	See the following table for the status shown by this LED.
4	NIC LED	This LED indicates network activity on either LAN1 or LAN2 when flashing.
5	Power	Indicates power is being supplied to the system power supply units. This LED is illuminated when the system is operating normally.

Information LED	
Status	Description
Continuously on and red	An overheat condition has occurred. (This may be caused by cable congestion.)
Blinking red (1 Hz)	Fan failure: check for an inoperative fan.
Blinking red (0.25 Hz)	Power failure: check for an inoperative power supply.
Solid blue	UID has been activated locally to locate the server in a rack environment.
Blinking blue (300 Msec)	UID has been activated using IPMI to locate the server in a rack environment.

Front Features

The SC809H-R1K05P3 is a mini 1U chassis. See the illustration below for the features included on the front of the chassis.

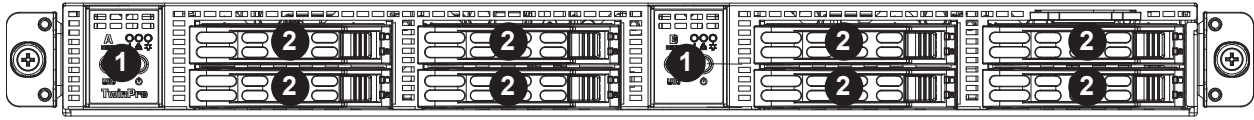

Figure 1-2. Chassis Front View

Front Chassis Features		
Item	Feature	Description
1	Control Panels (each Node)	One control panel is provided on the chassis front for each node in the system.
2	Drive Bays	Eight (8) drive bays for 2.5" drives are provided on the chassis front, four for each node.

Rear Features

The illustration below shows the features included on the rear of the chassis.

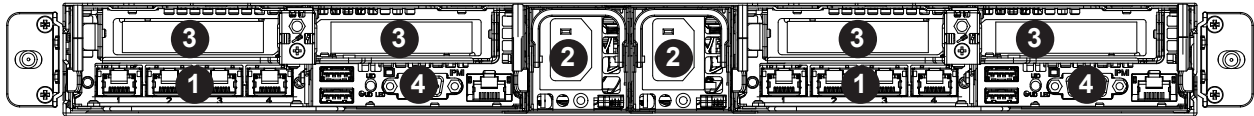
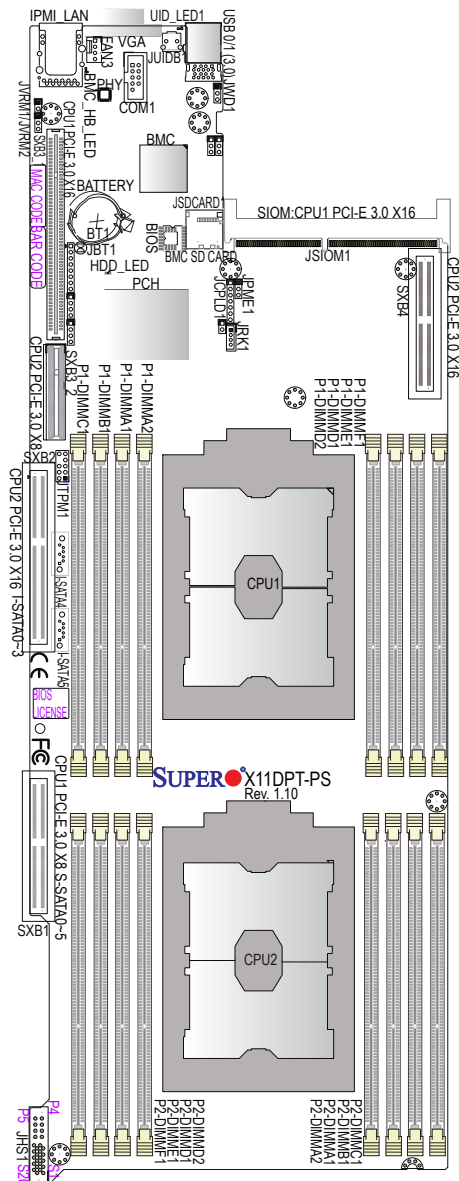

Figure 1-3. Chassis Rear View

Rear Chassis Features		
Item	Feature	Description
1	SIOM Module (2)	Installed SIOM module, see chapter 3 for details on the SIOM module.
2	Power Supply (2)	Bay for Power Supply
3	PCI-E Slots (4)	Chassis PCI-E slot opening
4	Rear I/O Ports (4)	See Chapter 4 for details on the rear I/O ports.

1.5 Motherboard Layout

Below is a layout of the X11DPT-PS with jumper, connector and LED locations shown. See the table on the following page for descriptions. For detailed descriptions, pinout information and jumper settings, refer to Chapter 4.



Quick Reference Table

Jumper	Description	Default Setting
JBT1	CMOS Clear	Open (Normal) (See Chpt. 3)
JPME1	Manufacturing Mode Select	Pins 1-2 (Normal)
JWD1	Watch Dog Timer Enable	Pins 1-2 (Reset)

Connector	Description
BT1	Onboard CMOS battery
COM1	COM port (COM1) for front access
FAN3	System cooling fan header
IPMI_LAN	Dedicated IPMI LAN port (IPMI_LAN1)
I-SATA4/I-SATA5	SATA3.0 ports with power-pins built-in w/support of SuperDOM (Device-On Module)
JHS1	SMCI proprietary power supply & front panel control header
JRK1	Intel RAID key for NVMe SDD
JSDCARD1	BMC_SD card header
JSIOM1	Super I/O Module (SIOM) used as CPU1 PCI-E 3.0 x16 slot
JTPM1	Trusted Platform Module/Port 80 connector
JUIDB1	UID (Unit Identifier) switch
SXB1	PCI-E 3.0 x8 slot (supported by CPU1) and SATA connection (S-SATA 0-5)
SXB2	PCI-E 3.0 x16 slot (supported by CPU2) and SATA connection (I-SATA 0-3)
SXB3_1	PCI-E 3.0 x16 slot supported by CPU1
SXB3_2	PCI-E 3.0 x8 slot supported by CPU2
SXB4	PCI-E 3.0 x16 slot supported by CPU2
USB0/1	Backplane Universal Serial Bus (USB) 3.0 ports 0/1
VGA	VGA Port

LED	Description	Status
BMC_HB_LED	BMC Heartbeat LED	Blinking Green: BMC Normal
HDD_LED	HDD LED	Blinking Green: HDD Active
UID_LED1	UID (Unit Identifier) LED	Solid Blue: Unit Identified

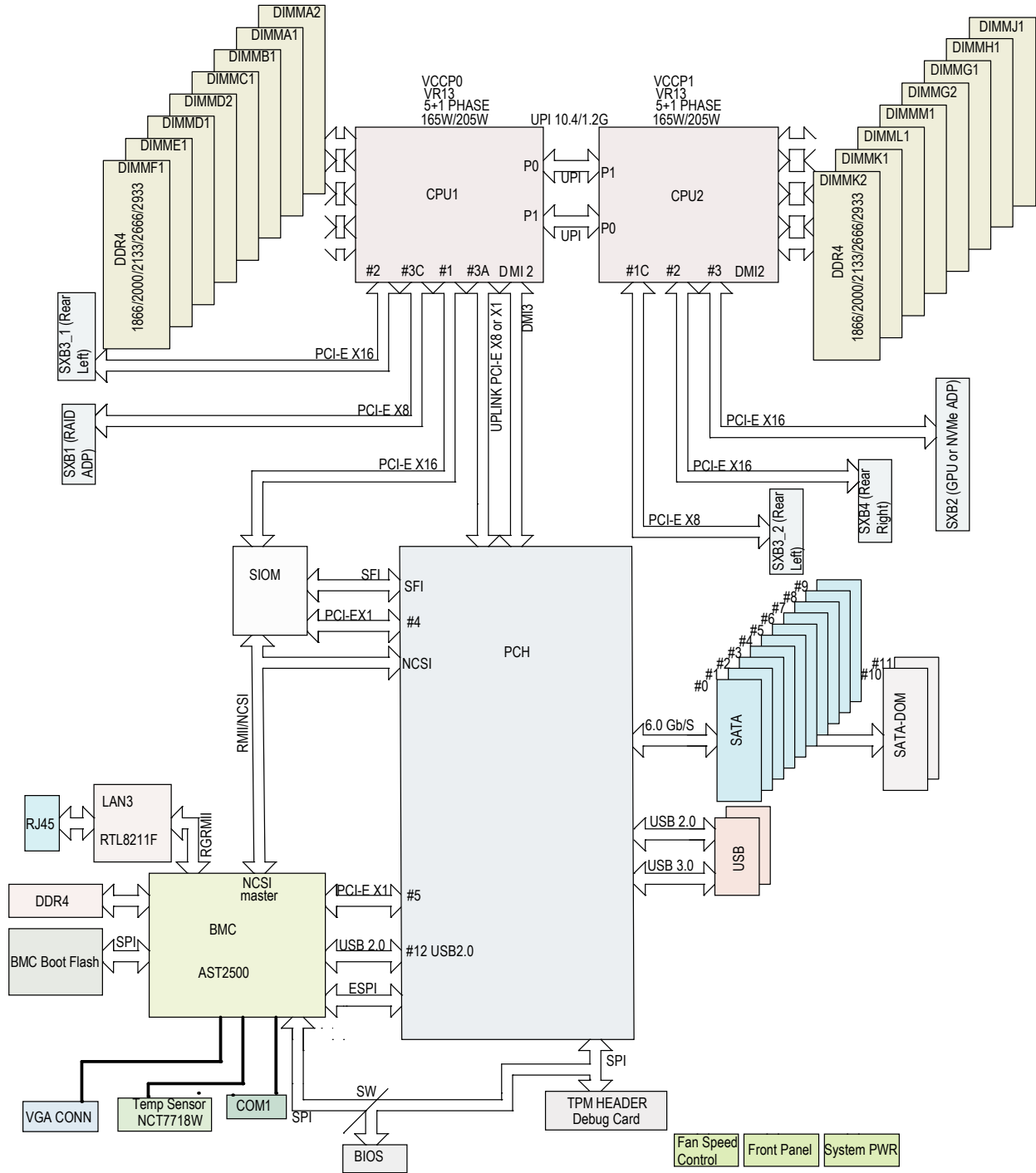

Figure 1-5. Intel C621 Chipset: System Block Diagram

Note: This is a general block diagram and may not exactly represent the features on your motherboard. See the System Specifications appendix for the actual specifications of your motherboard.

Chapter 2

Server Installation

2.1 Overview

This chapter provides advice and instructions for mounting your system in a server rack. If your system is not already fully integrated with processors, system memory etc., refer to Chapter 4 for details on installing those specific components.

Caution: Electrostatic Discharge (ESD) can damage electronic components. To prevent such damage to PCBs (printed circuit boards), it is important to use a grounded wrist strap, handle all PCBs by their edges and keep them in anti-static bags when not in use.

2.2 Preparing for Setup

The box in which the system was shipped should include the rackmount hardware needed to install it into the rack. Please read this section in its entirety before you begin the installation.

Choosing a Setup Location

- The system should be situated in a clean, dust-free area that is well ventilated. Avoid areas where heat, electrical noise and electromagnetic fields are generated.
- Leave enough clearance in front of the rack so that you can open the front door completely (~25 inches) and approximately 30 inches of clearance in the back of the rack to allow sufficient space for airflow and access when servicing.
- This product should be installed only in a Restricted Access Location (dedicated equipment rooms, service closets, etc.).
- This product is not suitable for use with visual display workplace devices according to §2 of the German Ordinance for Work with Visual Display Units.

Rack Precautions

- Ensure that the leveling jacks on the bottom of the rack are extended to the floor so that the full weight of the rack rests on them.
- In single rack installations, stabilizers should be attached to the rack. In multiple rack installations, the racks should be coupled together.
- Always make sure the rack is stable before extending a server or other component from the rack.

- You should extend only one server or component at a time - extending two or more simultaneously may cause the rack to become unstable.

Server Precautions

- Review the electrical and general safety precautions in Appendix B.
- Determine the placement of each component in the rack *before* you install the rails.
- Install the heaviest server components at the bottom of the rack first and then work your way up.
- Use a regulating uninterruptible power supply (UPS) to protect the server from power surges and voltage spikes and to keep your system operating in case of a power failure.
- Allow any drives and power supply modules to cool before touching them.
- When not servicing, always keep the front door of the rack and all covers/panels on the servers closed to maintain proper cooling.

Rack Mounting Considerations

Ambient Operating Temperature

If installed in a closed or multi-unit rack assembly, the ambient operating temperature of the rack environment may be greater than the room's ambient temperature. Therefore, consideration should be given to installing the equipment in an environment compatible with the manufacturer's maximum rated ambient temperature (TMRA).

Airflow

Equipment should be mounted into a rack so that the amount of airflow required for safe operation is not compromised.

Mechanical Loading

Equipment should be mounted into a rack so that a hazardous condition does not arise due to uneven mechanical loading.

Circuit Overloading

Consideration should be given to the connection of the equipment to the power supply circuitry and the effect that any possible overloading of circuits might have on overcurrent protection and power supply wiring. Appropriate consideration of equipment nameplate ratings should be used when addressing this concern.

Reliable Ground

A reliable ground must be maintained at all times. To ensure this, the rack itself should be grounded. Particular attention should be given to power supply connections other than the direct connections to the branch circuit (i.e. the use of power strips, etc.).



To prevent bodily injury when mounting or servicing this unit in a rack, you must take special precautions to ensure that the system remains stable. The following guidelines are provided to ensure your safety:

- This unit should be mounted at the bottom of the rack if it is the only unit in the rack.
- When mounting this unit in a partially filled rack, load the rack from the bottom to the top with the heaviest component at the bottom of the rack.
- If the rack is provided with stabilizing devices, install the stabilizers before mounting or servicing the unit in the rack.

2.3 Installing the System into a Rack

There are a variety of rack units on the market, which may require a slightly different assembly procedure. This rail set fits a rack between 25.6" and 33" deep.

The following is a basic guideline for installing the system into a rack with the rack mounting hardware provided. You should also refer to the installation instructions that came with the specific rack you are using.

If you are installing into a two-post "telco" rack, skip to that section later in this chapter.

Identifying the Rails

The chassis comes with two sets of rack rails, one set for the right side of the chassis and one for the left. Each set consists of an inner rail that is pre-attached to the chassis, and an outer rail that attaches to the rack.

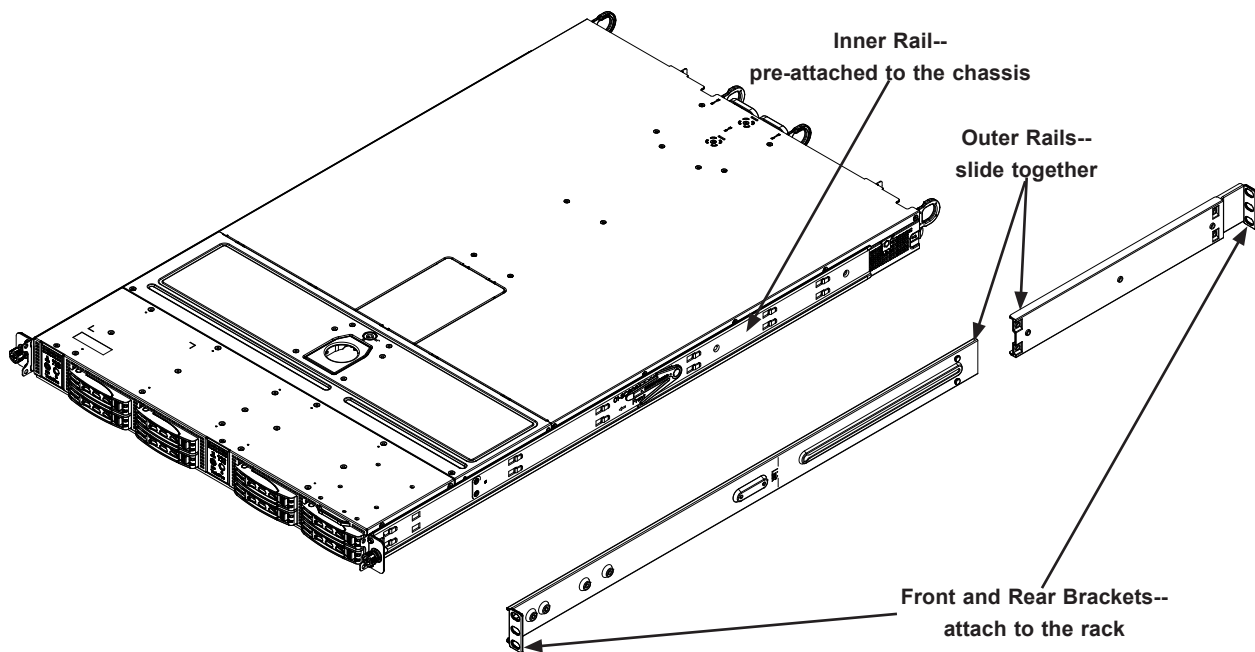

Figure 2-1. Identifying the Sections of the Rack Rails



Slide rail mounted equipment is not to be used as a shelf or a work space.



Warning: do not pick up the server with the front handles. They are designed to pull the system from a rack only.

Assembling the Outer Rails

Each outer rail comes in two sections that must be assembled before mounting onto the rack.

Assembling the Outer Rails

1. Identify the left and right outer rails by examining the ends, which bend outward. Match the left front outer rail with the left rear outer rail and the same for the right rails.
2. Align the round post in the rear rail (B) with the round hole at the end of the slot in the front rail (A), and slide the front section into the rear section.

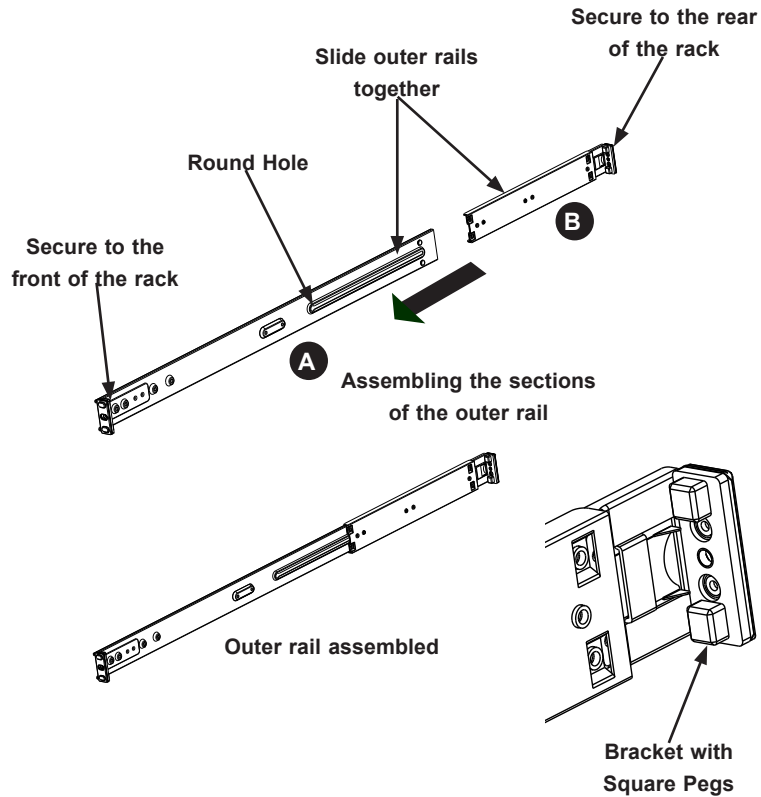

Figure 2-2. Assembling the Outer Rails

Installing the Outer Rails onto the Rack

Each end of the assembled outer rail includes a bracket with square pegs to fit into your rack holes. If you have an older rack with round holes, these brackets must be removed, and you must use screws to secure the rail to the rack.

Outer Rail Installation

1. Align the square pegs on the front end of the rail with the square holes on the front of the rack (C). Push the rail into the rack until the quick release bracket snaps into place, securing the rail to the rack. Keep the rail horizontal.
2. Adjust the rail to reach just past the full depth of your rack.
3. Align the square pegs on the rear end of the rail to the holes on the rack (D) and push the rail into the rack until the quick release bracket snaps into place, securing the rail to the rack.

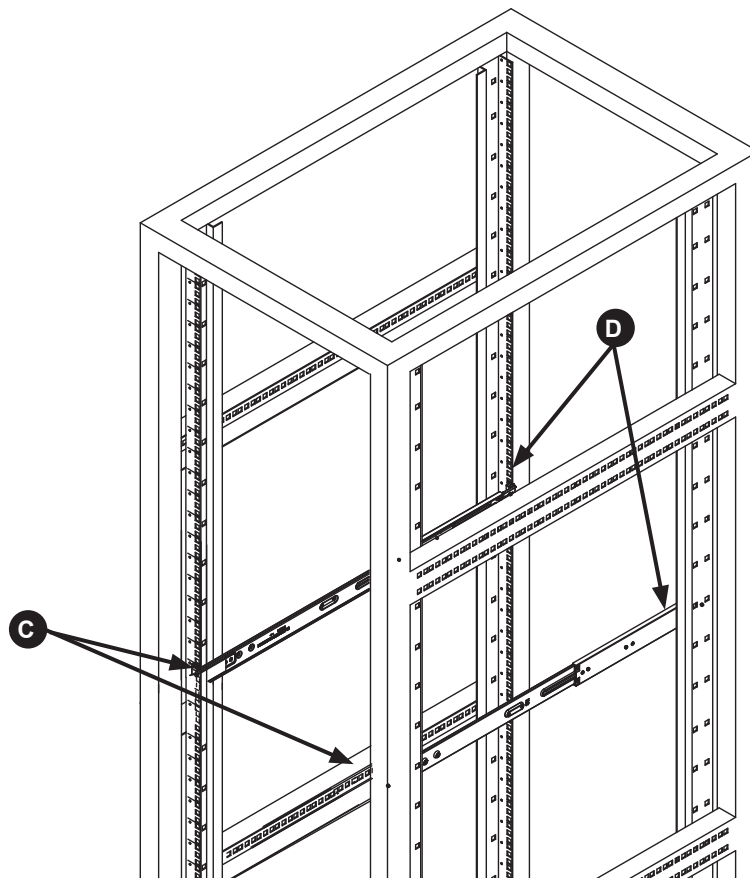

Figure 2-3. Installing the Outer Rails to the Rack

Note: The figure above is for illustrative purposes only. Always install servers at the bottom of the rack first.



Stability hazard. The rack stabilizing mechanism must be in place, or the rack must be bolted to the floor before you slide the unit out for servicing. Failure to stabilize the rack can cause the rack to tip over.

Sliding the Chassis onto the Rack Rails

Installing the Chassis into a Rack

1. Align the rear of the chassis rails with the front of the rack rails and then push evenly on both sides of the chassis. The spring latch engages when the chassis is part way in. Push the server completely into the rack.
2. (*Optional*) Insert and tighten the thumbscrews that hold the front of the server to the rack.

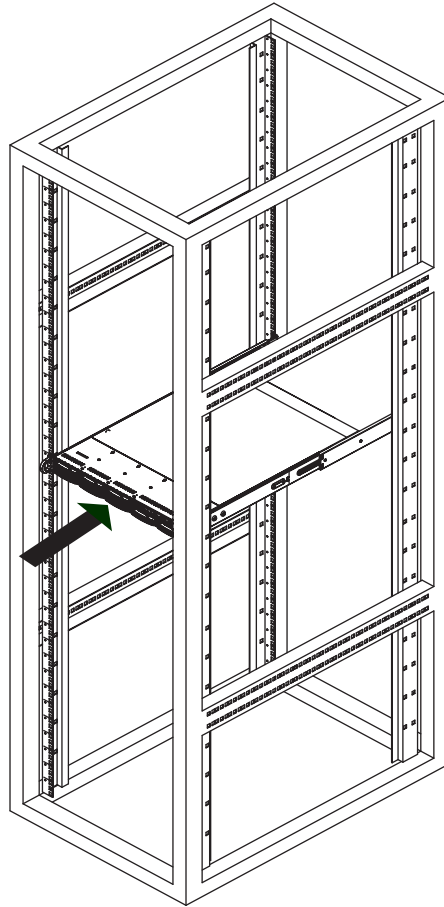

Figure 2-4. Installing the Server into a Rack

Note: The figure above is for illustrative purposes only. Always install servers at the bottom of the rack first.



Warning: Do not pick up the server with the front handles. They are designed to pull the system from a rack only.

Chapter 3

Maintenance and Component Installation

This chapter provides instructions on installing and replacing main system components. To prevent compatibility issues, only use components that match the specifications and/or part numbers given.

Installation or replacement of most components require that power first be removed from the system. Please follow the procedures given in each section.

3.1 Removing Power

Use the following procedure to ensure that power has been removed from the system. This step is necessary when removing or installing non hot-swap components or when replacing a non-redundant power supply.

1. Use the operating system to power down the system.
2. After the system has completely shut-down, disconnect the AC power cord(s) from the power strip or outlet. (If your system has more than one power supply, remove the AC power cords from all power supply modules.)
3. Disconnect the power cord(s) from the power supply module(s).

3.2 Accessing the System

The features a removable top cover, which allows easy access to the inside of the chassis.

Removing the Top Cover

1. Unplug the AC power cord from any external power source.
2. Use the key to unlock the cover lock.
3. Lift the latch, pulling up and toward the chassis front.

Warning: Except for short periods of time, do not operate the server without the cover in place. The chassis cover must be in place to allow for proper airflow and to prevent overheating.

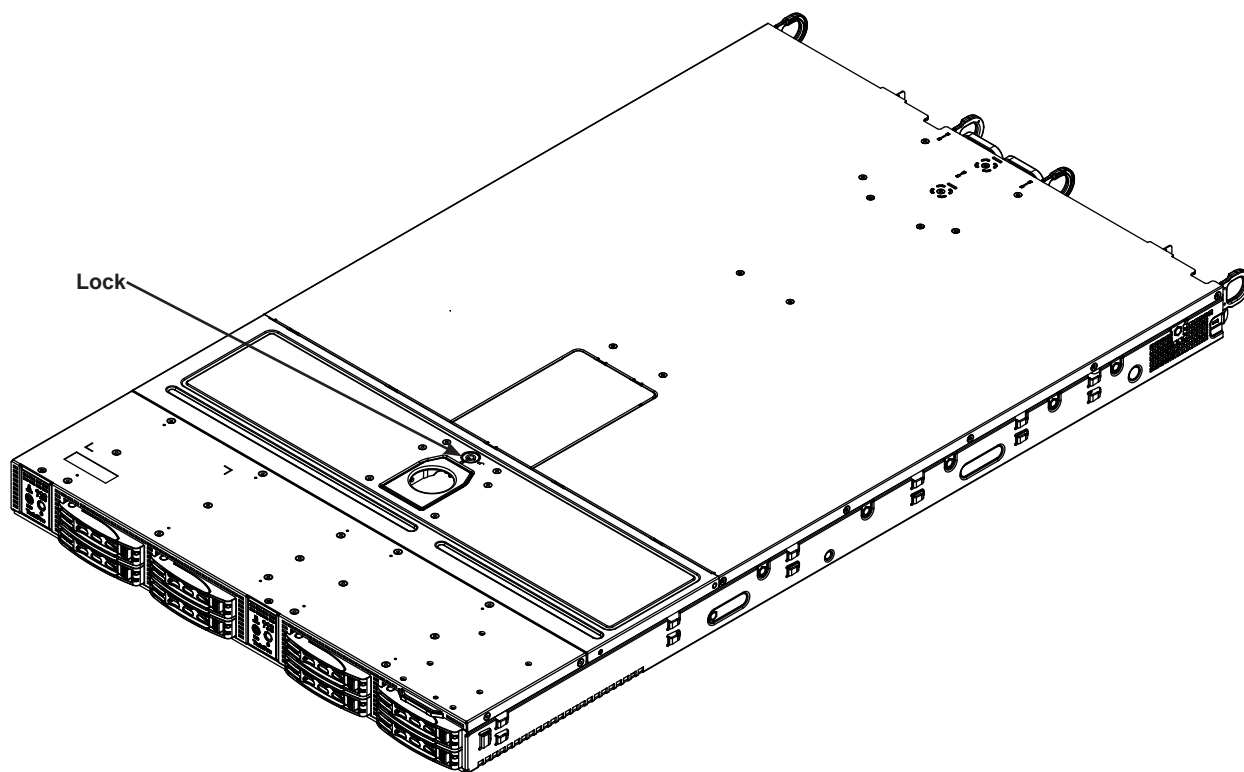

Figure 3-1. Unlocking the Cover Lock

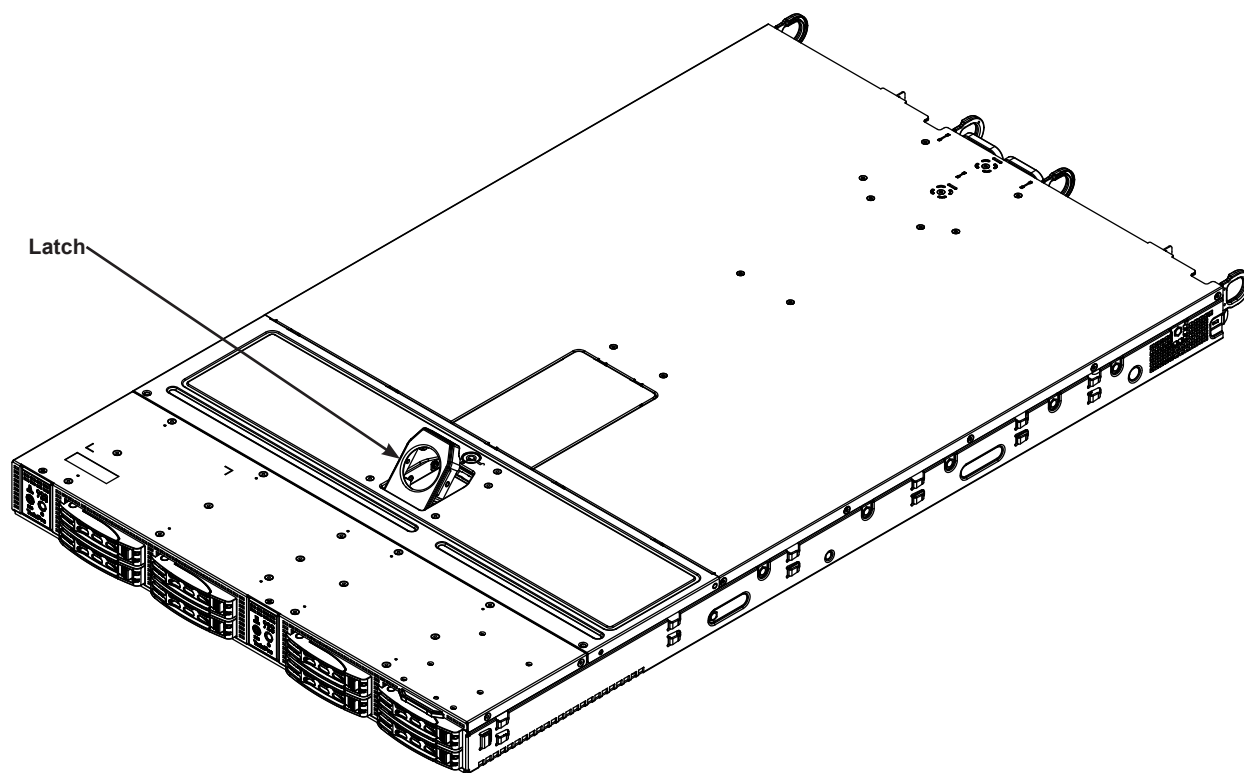

Figure 3-2. Pulling the Cover Latch

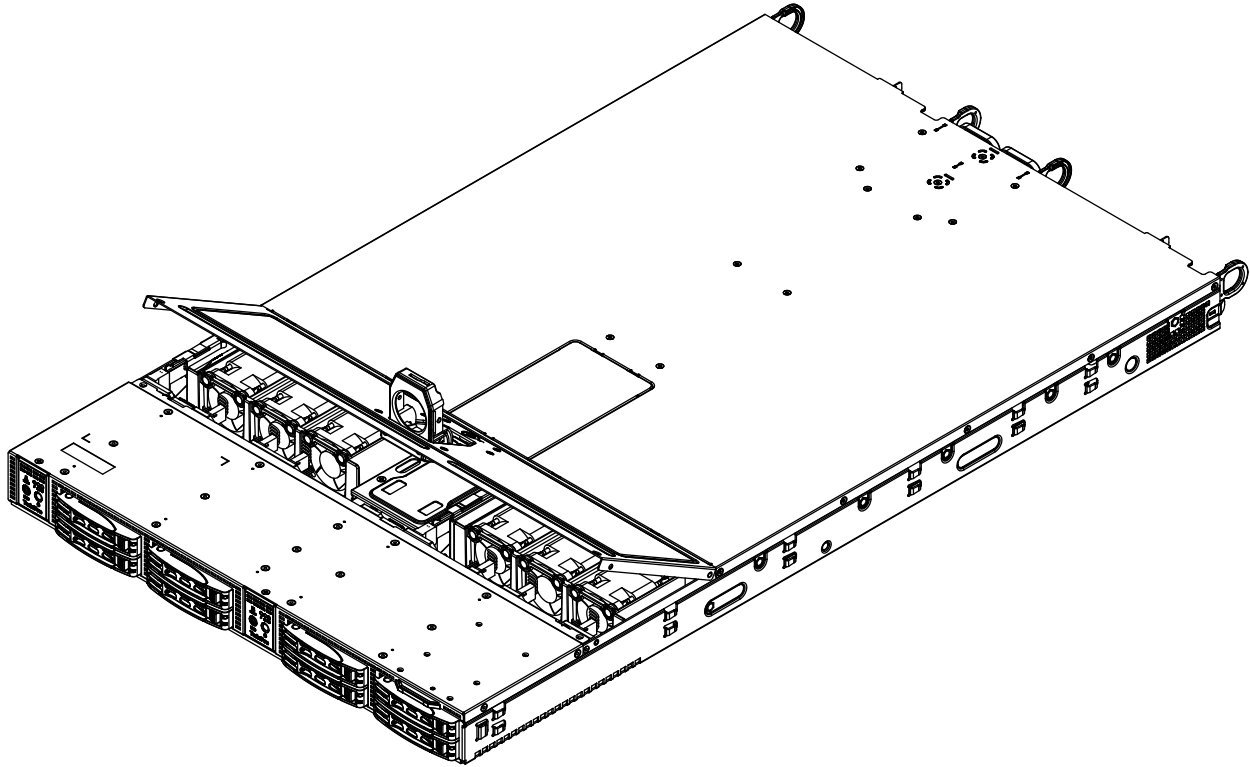

Figure 3-3. Cover Open

3.3 Motherboard Components

Processor and Heatsink Installation

The Intel® Xeon 81xx/61xx/51xx/41xx/31xx and 82xx/62xx/52xx/42xx/32xx series processor comes in two models: Fabric (F model) and Non-Fabric (Non-F model). Only the Non-Fabric model is supported for this system.

The processor (CPU) and heatsink should be assembled together first to form the processor heatsink module (PHM), and then install the PHM into the CPU socket.

Caution: Use ESD protection. Do not touch the underside of the CPU. Improper installation or socket misalignment can cause serious damage to the CPU or socket which may require manufacturer repairs.

Notes:

- All power should be off, as described in Section 3.1, before installing the processors.
- When handling the processor package, avoid placing direct pressure on the label area of the CPU or socket.
- Check that the plastic socket dust cover is in place and none of the socket pins are bent—otherwise, contact your retailer.
- Refer to the Supermicro website for updates on CPU support.
- Graphics in this manual are for illustration. Your components may look slightly different.

The Xeon Series Processor

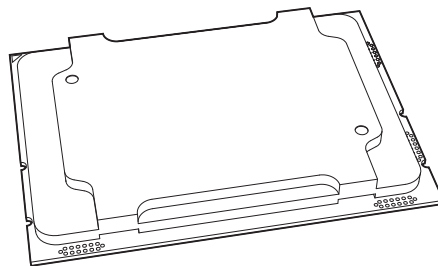

Non-F model Processor

Note: All graphics, drawings, and pictures shown in this manual are for illustration only. The components that came with your machine may or may not look exactly the same as those shown in this manual.

Assembling the Processor Package

Attach the processor to the thin processor clip to create the processor package.

1. On the top corner of the CPU, locate pin 1 (A), marked by a triangle. Also, locate notch B and notch C (and notch D for F models) on the CPU as shown below.
2. On the top of the processor clip, locate the corner marked by a hollow triangle as the position for pin 1. Also locate notch B and notch C (and D for F models) on the processor clip.
3. Align pin 1 of the CPU with its proper position on the processor clip and carefully insert the CPU into the processor clip. Slide notch B of the CPU into tab B of the processor clip, and slide notch C of the CPU into tab C of the processor clip (and D for F models) until the processor clip tabs snap onto the CPU.
4. Examine all corners to ensure that the CPU is properly seated and secure on the processor clip.

The processor package assembly is created.

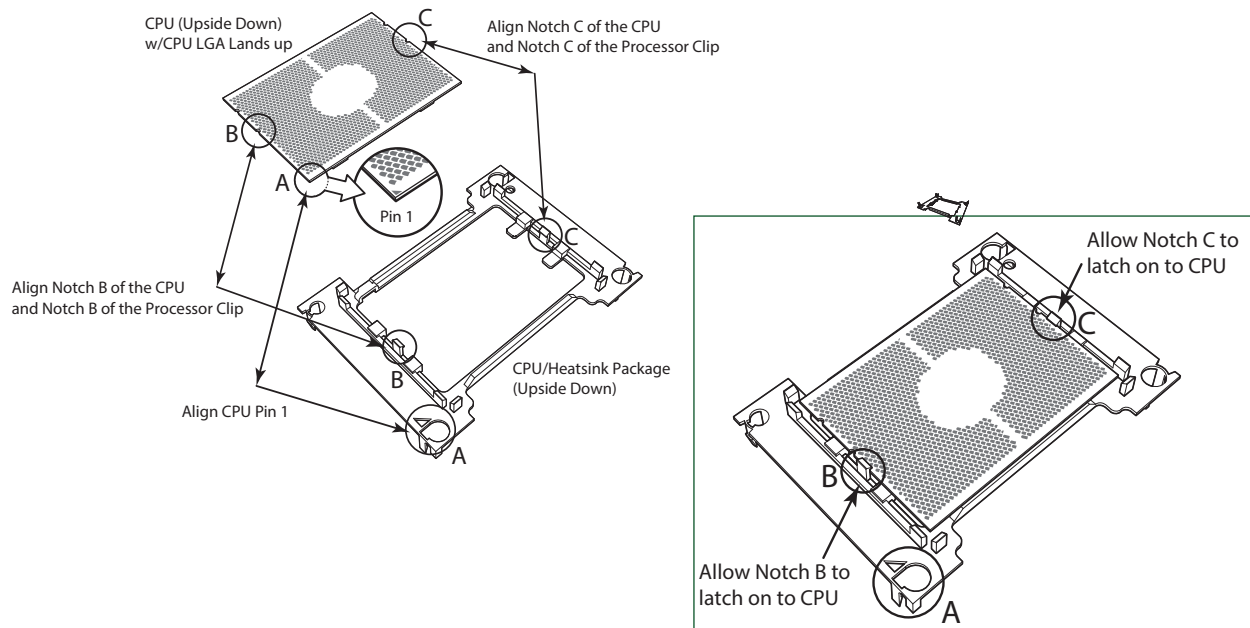

Processor Package Assembly for the non-F Model Processors

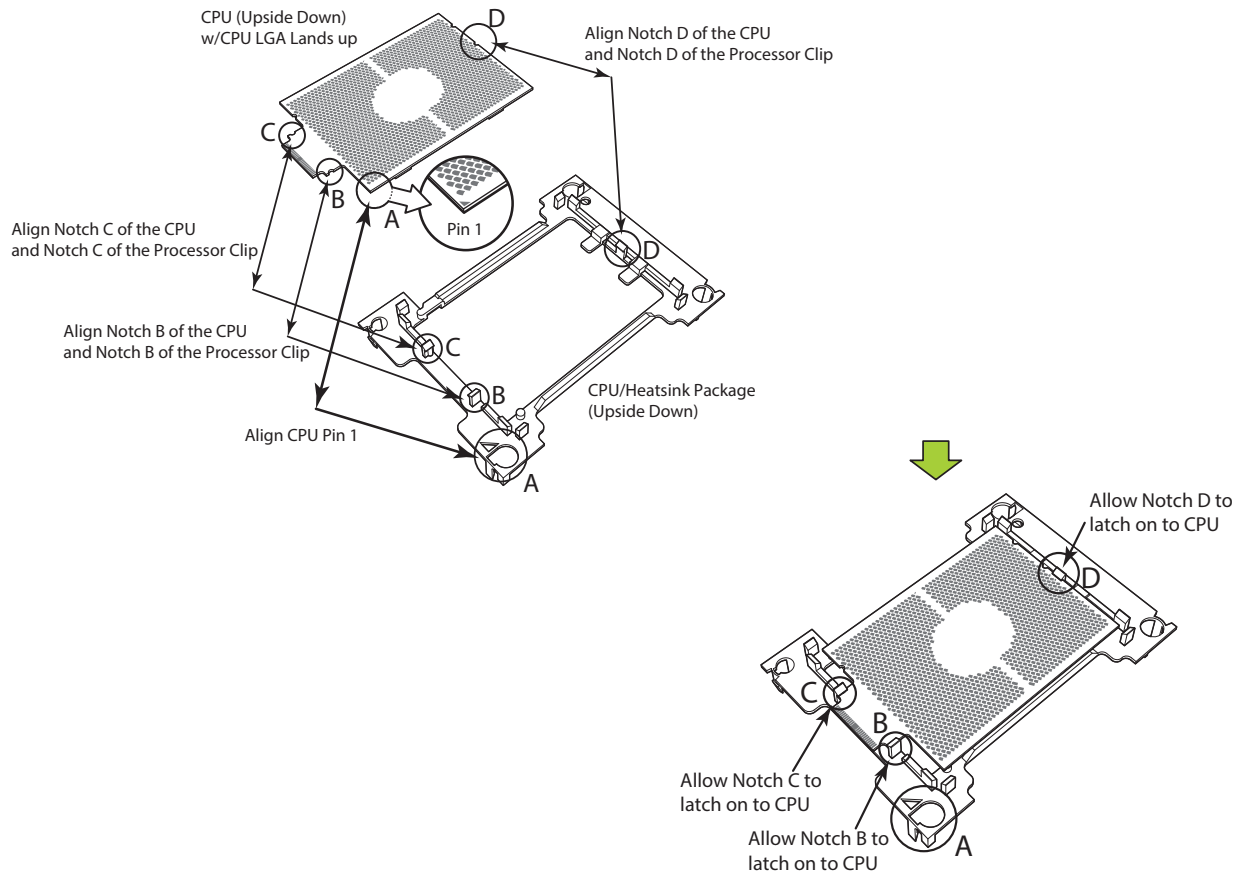

Processor Package Assembly for the F Model Processors

After creating the processor package assembly, mount it onto the heatsink to create the processor heatsink module (PHM).

1. On the heatsink label, locate "1" and the corner next to it. Turn the heatsink upside down with the thermal grease side facing up, keeping track of the "1" corner.
2. Remove the protective thermal film if present. If this is a new heatsink, the necessary thermal grease has been pre-applied in the factory. If the heatsink is not new, apply the proper amount of the thermal grease.
3. In the plastic processor clip, locate the hollow triangle at the corner ("a" in the drawing below) next to a hole and plastic mounting clips. There is a similar hole and mounting clips at the diagonal corner of the of the processor clip ("b" in the drawing).
4. With the underside of heatsink and the underside of the processor package facing up, align the "1" corner on the heatsink ("A" in the drawing) against the mounting clips next to the hollow triangle ("a") on the processor package.
5. Also align the corner ("B") at the diagonal side of the heatsink with the corresponding clips on the processor package ("b").
6. Once aligned, press the processor package assembly onto the heatsink until the mounting clips (at a, b, c, and d) snap into place.

The processor heatsink module is assembled.

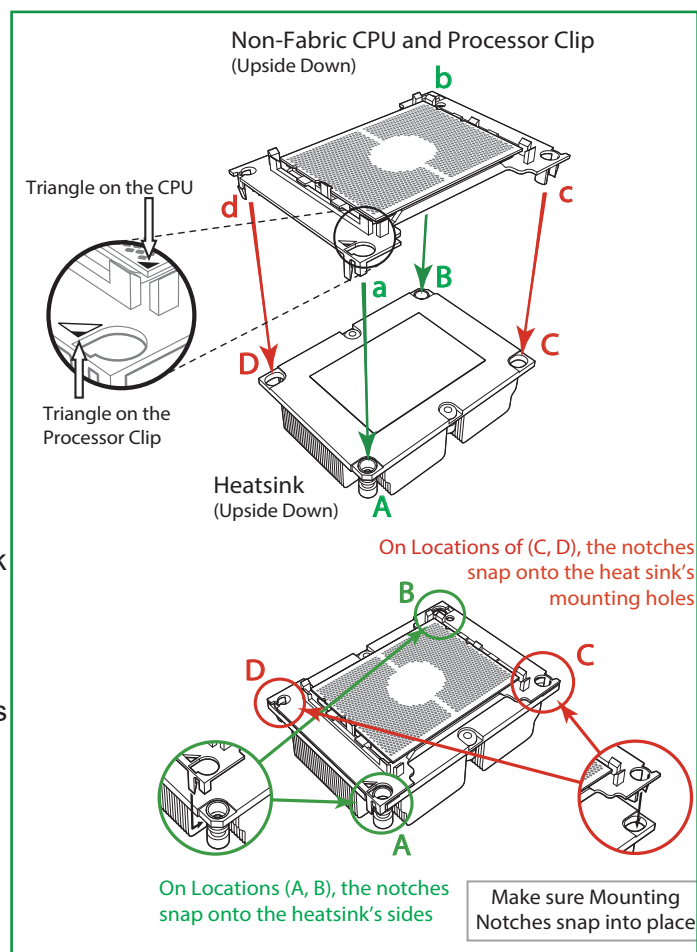

Assembling the Processor Heatsink Module

Removing the Dust Cover from the CPU Socket

Remove the dust cover from the CPU socket, exposing the socket pins as shown below.

Caution: Do not touch the socket pins.

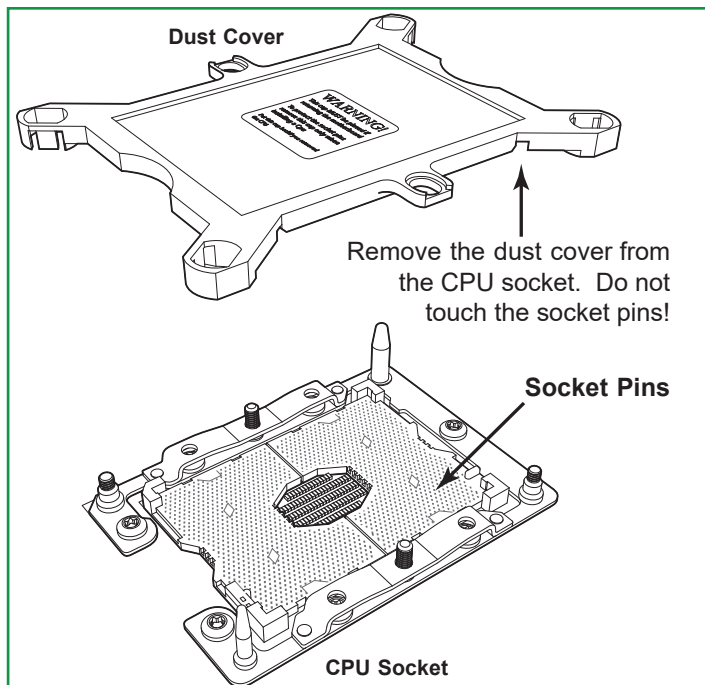

Removing the Socket Dust Cover

Installing the Processor Heatsink Module (PHM)

1. Locate the triangle (pin 1) on the CPU socket. Also locate the pin 1 corner of the PHM that is closest to "1" on the heatsink label. To confirm, look at the underside of the PHM and note the hollow triangle in the processor clip and printed triangle on the CPU located next to a screw at the corner.
2. Align the pin 1 corner of the PHM over the pin 1 corner on the CPU socket.
3. Align the two holes at diagonal corners of the PHM onto the two guide posts on the socket bracket and carefully lower the PHM onto the socket.
4. Use a T30 Torx-bit screwdriver to install four screws into the mounting holes on the socket to securely attach the PHM onto the motherboard in the sequence of 1, 2, 3, and 4, as marked on the heatsink label. Gradually tighten each to assure even pressure.

Note: Use only 12 foot-pounds of torque when tightening the screws to avoid damaging the processor or the socket.

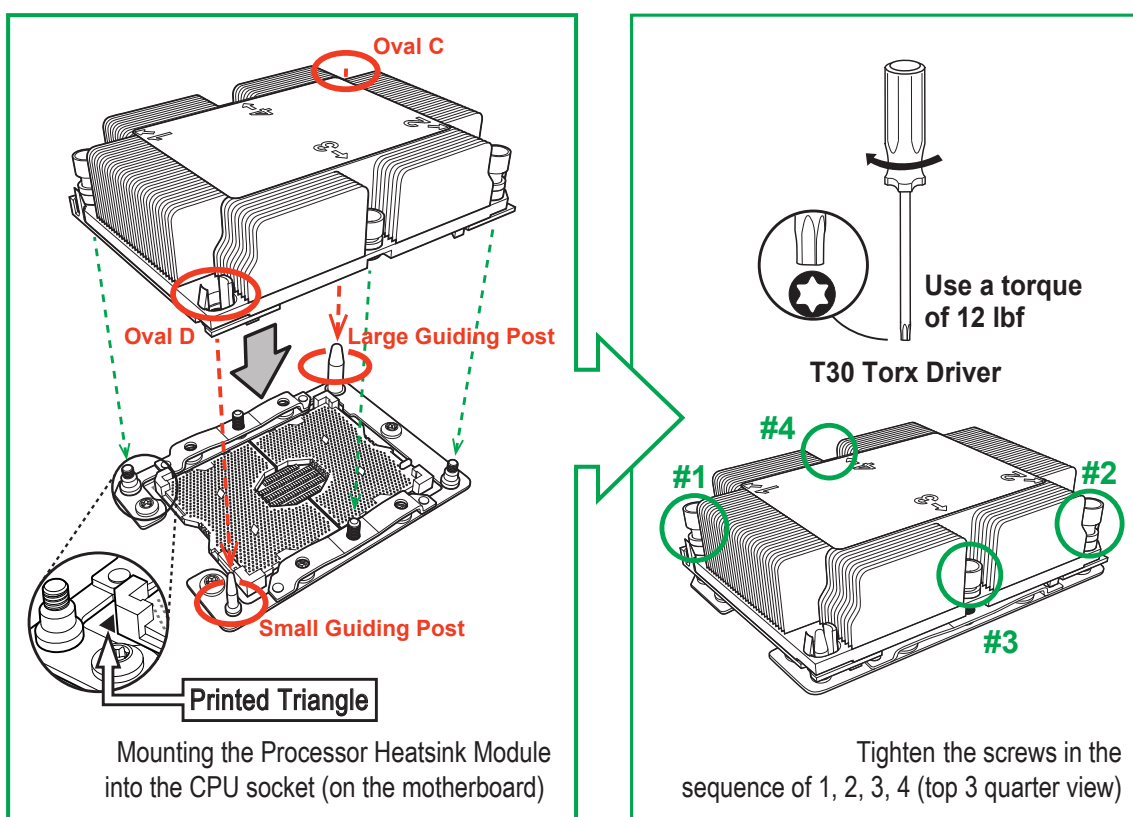

Installing the Processor Heatsink Module

Removing the Processor Heatsink Module from the Motherboard

Before removing the processor heatsink module (PHM), power down as described in Section 3.1.

1. Using a T30 Torx-bit screwdriver, loosen and remove the screws on the PHM from the socket, starting with the screw marked #4, in the sequence of 4, 3, 2, 1.
2. Pull up the PHM while releasing the small snap tabs on two corners of the socket.

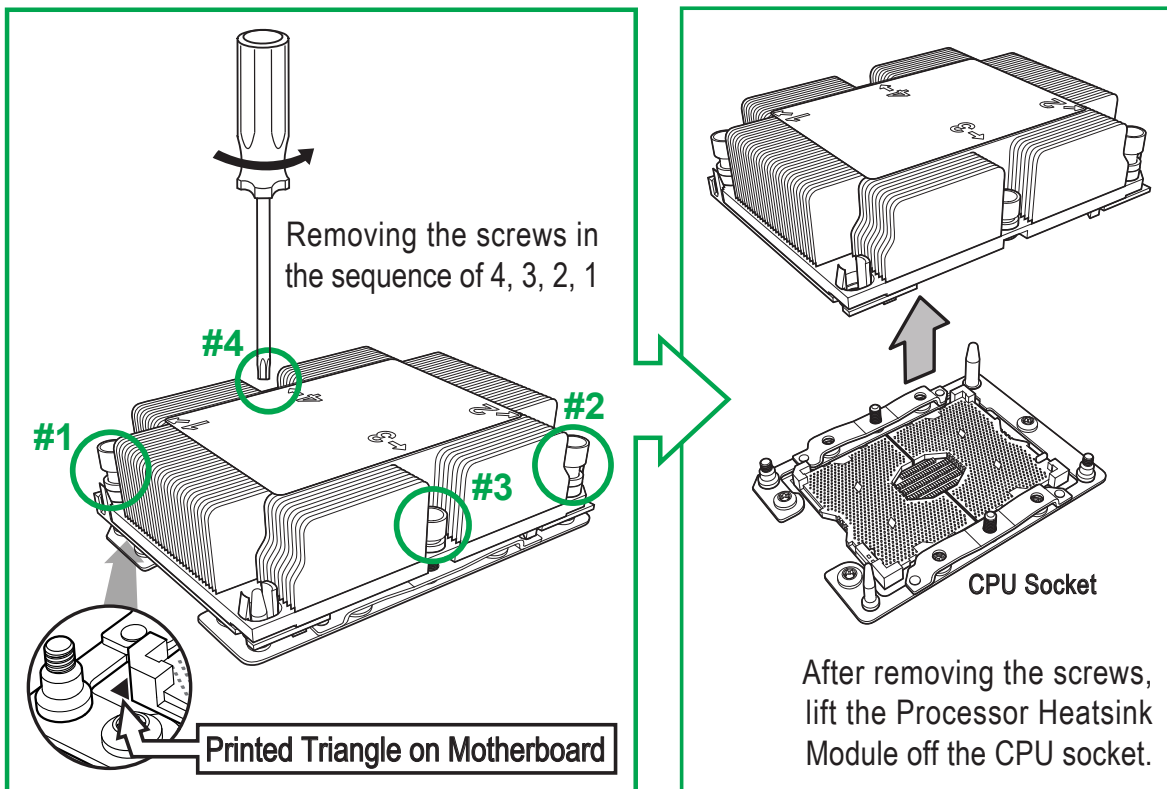

Removing the Processor Heatsink Module

Memory Installation

ESD Precautions

Electrostatic Discharge (ESD) can damage electronic components including memory modules. To avoid damaging your DIMM modules, it is important to handle it very carefully. The following measures are generally sufficient to protect your equipment from ESD.

Precautions

- Use a grounded wrist strap designed to prevent static discharge.
- Handle the memory module by its edges only.
- Put the memory modules into the antistatic bags when not in use.
- Check the Supermicro website for recommended memory modules

Introduction to Intel® Optane DC Persistent Memory

Intel® 82xx/62xx/52xx/42xx supports new DCPMM (Optane™ DC Persistent Memory Modules) technology. DCPMM offers data persistence with higher capacity at lower latencies than the existing memory modules and provides hyper-speed storage capability for high performance computing platforms with flexible configuration options.

Memory Support

The motherboard features 16 DIMM slots that can support up to 2 TB of Load Reduced (3DS LRDIMM) ECC DDR4 2933/2666/2400/2133/1866/1600/1333 MHz speed memory.

Refer to the following tables for detailed information on memory support for the X11 UP/DP/MP motherboards.

Note: 2933 MHz memory is supported by the 82xx/62xx series processors only.

DDR4 Memory Support for 81xx/61xx/51xx/41xx/31xx Processors						
Type	Ranks Per DIMM and Data Width	DIMM Capacity (GB)		Speed (MT/s)		
				One Slot per Channel	Two Slots per Channel	
		DRAM Density		One DIMM per Channel	One DIMM per Channel	Two DIMMs per Channel
		4 Gb	8 Gb	1.2 Volts	1.2 Volts	1.2 Volts
RDIMM	SRx4	4 GB	8 GB	2666	2666	2666
	SRx8	8 GB	16 GB			
	DRx8	8 GB	16 GB			
	DRx4	16 GB	32 GB			
RDIMM 3Ds	QRX4	N/A	2H-64GB			
	8RX4	N/A	4H-128GB			
LRDIMM	QRx4	32 GB	64 GB			
LRDIMM 3Ds	QRx4	N/A	2H-64GB			
	8Rx4	N/A	4H-128 GB			

DDR4 Memory Support for 82xx/62xx/52xx/42xx/32xx Processors							
Type	Ranks Per DIMM and Data Width	DIMM Capacity (GB)			Speed (MT/s)		
					One Slot per Channel	Two Slots per Channel	
		DRAM Density			One DIMM per Channel	One DIMM per Channel	Two DIMMs per Channel
		4 Gb	8 Gb	16 Gb	1.2 Volts	1.2 Volts	1.2 Volts
RDIMM	SRx4	4 GB	8 GB	16 GB	2933	2933	2933
	SRx8	8 GB	16 GB	32 GB			
	DRx8	8 GB	16 GB	32 GB			
	DRx4	16 GB	32 GB	64 GB			
RDIMM 3Ds	QRX4	N/A	2H-64GB	2H-128GB			
	8RX4	N/A	4H-128GB	4H-256GB			
LRDIMM	QRx4	32 GB	64 GB	128 GB			
LRDIMM 3Ds	QRx4	N/A	2H-64GB	2H-64GB			
	8Rx4	N/A	4H-128 GB	4H-256 GB			

Memory Installation Sequence

Memory modules for the X11 UP/DP/MP motherboards are populated using the "Fill First" method. The blue memory slot of each channel is considered the "first DIMM module" of the channel, and the black slot, the second module of the channel. When installing memory modules, be sure to populate the blue memory slots first and then populate the black slots. To maximize memory capacity and performance, please populate all DIMM slots on the motherboard, including all blue slots and black slots.

General Memory Population Requirements

1. Be sure to use the memory modules of the same type and speed on the motherboard. Mixing of memory modules of different types and speeds is not allowed.
2. Using unbalanced memory topology such as populating two DIMMs in one channel while populating one DIMM in another channel on the same motherboard will result in reduced memory performance.
3. Populating memory slots with a pair of DIMM modules of the same type and size will result in interleaved memory, which will improve memory performance.

DIMM Population Guidelines for Optimal Performance

For optimal memory performance, follow the instructions listed in the tables below when populating memory modules.

Key Parameters for DIMM Configuration

Key Parameters for DIMM Configurations	
Parameters	Possible Values
Number of Channels	1, 2, 3, 4, 5, or 6
Number of DIMMs per Channel	1DPC (1 DIMM Per Channel) or 2DPC (2 DIMMs Per Channel)
DIMM Type	RDIMM (w/ECC), 3DS RDIMM, LRDIMM, 3DS LRDIMM
DIMM Construction	non-3DS RDIMM Raw Cards: A/B (2Rx4), C (1Rx4), D (1Rx8), E (2Rx8) 3DS RDIMM Raw Cards: A/B (4Rx4) non-3DS LRDIMM Raw Cards: D/E (4Rx4) 3DS LRDIMM Raw Cards: A/B (8Rx4)

DIMM Mixing Guidelines

General DIMM Mixing Guidelines	
<ul style="list-style-type: none"> • All DIMMs must be all DDR4 DIMMs. • x4 and x8 DIMMs can be mixed in the same channel. • Mixing of LRDIMMs and RDIMMs is not allowed in the same channel, across different channels, and across different sockets. • Mixing of non-3DS and 3DS LRDIMM is not allowed in the same channel, across different channels, and across different sockets. 	

Mixing of DIMM Types within a Channel			
DIMM Types	RDIMM	LRDIMM	3DS LRDIMM
RDIMM	Allowed	Not Allowed	Not Allowed
LRDIMM	Not Allowed	Allowed	Not Allowed
3DS LRDIMM	Not Allowed	Not Allowed	Allowed

Note: Unbalanced memory configuration decreases memory performance and is not recommended for Supermicro motherboards.

Memory Population Table for the X11DP Motherboard w/16 DIMM Slots Onboard	
CPUs/DIMMs	Memory Population Sequence
1 CPU & 1 DIMM	CPU1: P1-DIMMA1
1 CPU & 2 DIMMs	CPU1: P1-DIMMA1/P1-DIMMD1
1 CPU & 3 DIMMs	CPU1: P1-DIMMC1/P1-DIMMB1/P1-DIMMA1
1 CPU & 4 DIMMs	CPU1: P1-DIMMB1/P1-DIMMA1/P1-DIMMD1/P1-DIMME1
1 CPU & 5 DIMMs*	CPU1: P1-DIMMC1/P1-DIMMB1/P1-DIMMA1/P1-DIMMD1/P1-DIMME1
1 CPU & 6 DIMM	CPU1: P1-DIMMC1/P1-DIMMB1/P1-DIMMA1/P1-DIMMD1/P1-DIMME1/P1-DIMMF1
1 CPU & 7 DIMMs*	CPU1: P1-DIMMC1/P1-DIMMB1/P1-DIMMA1/P1-DIMMA2/P1-DIMMD1/P1-DIMME1/P1-DIMMF1
1 CPU & 8 DIMMs*	CPU1: P1-DIMMC1/P1-DIMMB1/P1-DIMMA1/P1-DIMMA2/P1-DIMMD2/P1-DIMMD1/P1-DIMME1/P1-DIMMF1
2 CPUs & 2 DIMMs	CPU1: P1-DIMMA1 CPU2: P2-DIMMA1
2 CPUs & 4 DIMMs	CPU1: P1-DIMMA1/P1-DIMMD1 CPU2: P2-DIMMA1/P2-DIMMD1
2 CPUs & 6 DIMMs	CPU1: P1-DIMMC1/P1-DIMMB1/P1-DIMMA1 CPU2: P2-DIMMC1/P2-DIMMB1/P2-DIMMA1
2 CPUs & 8 DIMMs	CPU1: P1-DIMMB1/P1-DIMMA1/P1-DIMMD1/P1-DIMME1 CPU2: P2-DIMMB1/P2-DIMMA1/P2-DIMMD1/P2-DIMME1
2 CPUs & 10 DIMMs	CPU1: P1-DIMMC1/P1-DIMMB1/P1-DIMMA1/P1-DIMMD1/P1-DIMME1/P1-DIMMF1 CPU2: P2-DIMMB1/P2-DIMMA1/P2-DIMMD1/P2-DIMME1
2 CPUs & 12 DIMMs	CPU1: P1-DIMMC1/P1-DIMMB1/P1-DIMMA1/P1-DIMMD1/P1-DIMME1/P1-DIMMF1 CPU2: P2-DIMMC1/P2-DIMMB1/P2-DIMMA1/P2-DIMMD1/P2-DIMME1/P2-DIMMF1
2 CPUs & 14 DIMMs*	CPU1: P1-DIMMC1/P1-DIMMB1/P1-DIMMA1/P1-DIMMA2/P1-DIMMD1/P1-DIMME1/P1-DIMMF1 CPU2: P2-DIMMC1/P2-DIMMB1/P2-DIMMA1/P2-DIMMA2/P2-DIMMD1/P2-DIMME1/P2-DIMMF1
2 CPUs & 16 DIMMs*	CPU1: P1-DIMMC1/P1-DIMMB1/P1-DIMMA1/P1-DIMMA2/P1-DIMMD2/P1-DIMMD1/P1-DIMME1/P1-DIMMF1 CPU2: P2-DIMMC1/P2-DIMMB1/P2-DIMMA1/P2-DIMMA2/P2-DIMMD2/P2-DIMMD1/P2-DIMME1/P2-DIMMF1

*Unbalanced, not recommended.

Note: The drawing at right shows DIMM module population for each CPU installed on the motherboard. Please install your processors starting with CPU Socket 1.

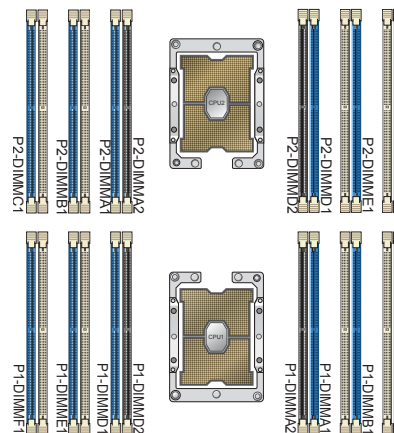

DIMM Installation

1. Follow the instructions given in the memory population guidelines listed in the previous sections to install memory modules on your motherboard. For the system to work properly, please use memory modules of the same type and speed on the motherboard. (See the Note below.)
2. Push the release tabs outwards on both ends of the DIMM slot to unlock it.
3. Align the key of the DIMM module with the receptive point on the memory slot.
4. Align the notches on both ends of the module against the receptive points on the ends of the slot.
5. Use two thumbs together to press the DIMM module straight down into the slot until the module snaps into place.
6. Press the release tabs to the lock positions to secure the DIMM module into the slot.

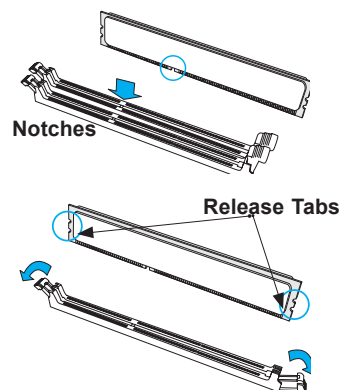
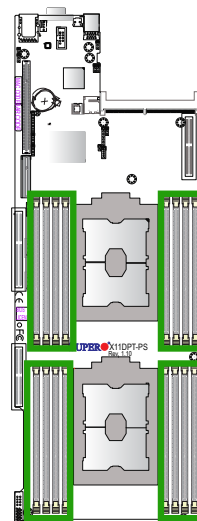

Insert the DIMM module into the memory slot.

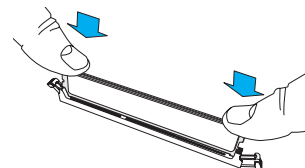

DIMM Module Removal

Press the release tabs on both ends of the DIMM socket to release the DIMM module from the socket as shown in the drawing on the right.

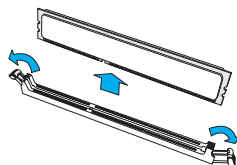

Warning! 1. To avoid damage to the DIMM module or the DIMM socket, do not use excessive force when pressing the release tabs on the ends of the DIMM socket. **2.** Handle DIMM modules with care. Carefully follow all the instructions given in Section 1 of this user guide to avoid ESD-related damage to your components or system. **3.** All graphics, including the layout drawing above, are for reference only. Your system components may or may not look the same as shown in this user guide.

PCI Expansion Card Installation

The system includes a pre-installed riser card (p/n CSE-RR1U-E8) that positions a standard size PCI-E x8 card at a 90 degree angle, allowing it to fit inside the chassis.

Installing PCI Expansion Cards

The riser card has already been pre-installed into the motherboard. Perform the following steps to install an add-on card:

Begin by removing power from the system as described in section 3.1.

1. Remove the chassis cover to access the inside of the system.
2. Remove the PCI slot shield on the chassis by releasing the locking tab.
3. Insert the expansion (add-on) card into the riser card.
4. Secure the card with the locking tab.

Motherboard Battery

The motherboard uses non-volatile memory to retain system information when system power is removed. This memory is powered by a lithium battery residing on the motherboard.

Replacing the Battery

Begin by removing power from the system as described in section 3.1.

1. Push aside the small clamp that covers the edge of the battery. When the battery is released, lift it out of the holder.
2. To insert a new battery, slide one edge under the lip of the holder with the positive (+) side facing up. Then push the other side down until the clamp snaps over it.

Note: Handle used batteries carefully. Do not damage the battery in any way; a damaged battery may release hazardous materials into the environment. Do not discard a used battery in the garbage or a public landfill. Please comply with the regulations set up by your local hazardous waste management agency to dispose of your used battery properly.

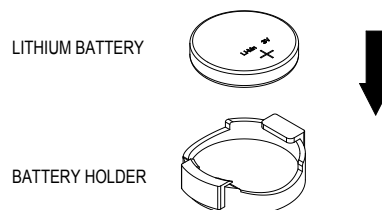

Figure 3-4. Installing the Onboard Battery

Warning: There is a danger of explosion if the onboard battery is installed upside down (which reverses its polarities). This battery must be replaced only with the same or an equivalent type recommended by the manufacturer (CR2032).

3.4 Chassis Components

Installing Hard Drives

The drives are mounted in drive carriers to simplify their installation and removal from the chassis. These carriers also help to promote proper airflow for the drive bays. For this reason, even carriers without drives must remain in the chassis.

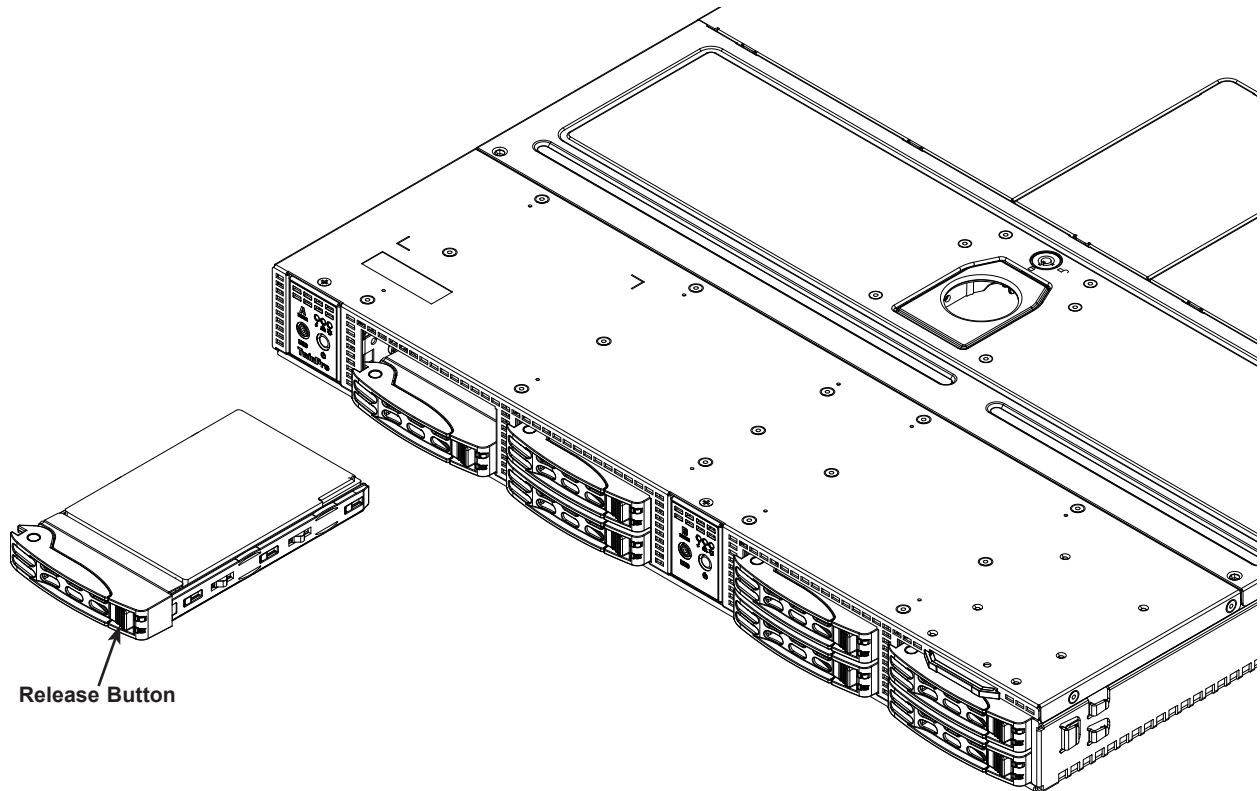

Figure 3-5. Removing a Hard Drive

Note: Enterprise level hard disk drives are recommended for use in Supermicro chassis and servers. For information on recommended HDDs, visit the Supermicro website at <http://www.supermicro.com/products/nfo/files/storage/SBB-HDDCompList.pdf>

Removing Hard Drive Carrier from the Chassis

1. Press the release button on the drive carrier. This extends the drive carrier handle.
2. Use the handle to pull the drive out of the chassis.
3. Remove the dummy drive from the carrier (Figure 3-6).

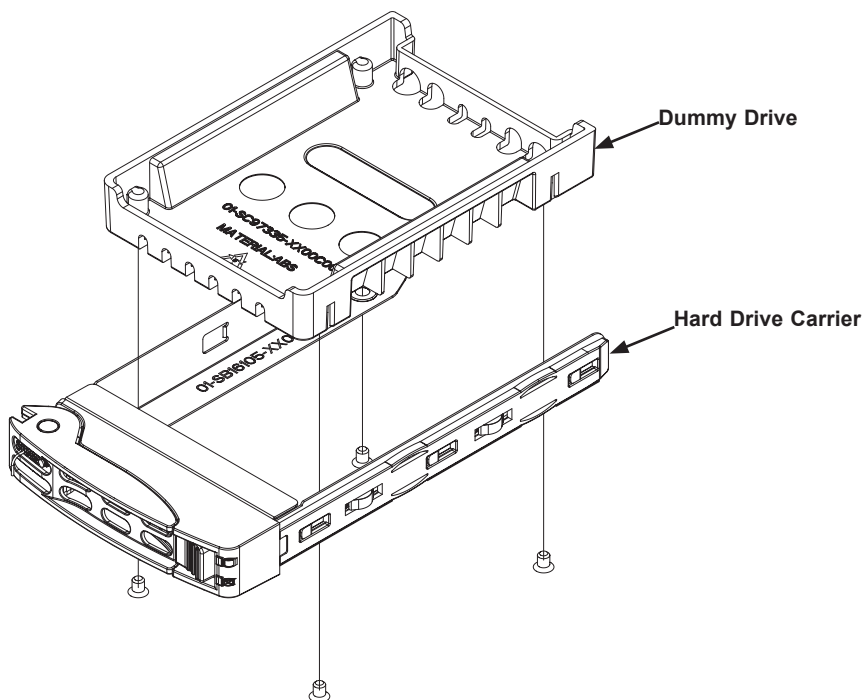

Figure 3-6. Mounting a Drive in a Carrier

Caution! Except for short periods of time while swapping hard drives, do not operate the server with the hard drives empty.

Installing a Drive into the Carrier

1. Remove the dummy drive from the carrier by removing four screws.
2. Install a new drive into the carrier with the printed circuit board side facing down so that the mounting holes in the drive align with those in the carrier.
3. Secure the hard drive into the carrier with the screws.
4. Open the drive carrier handle and use it to push the carrier assembly into the chassis.
5. Gently close the drive carrier handle to secure the drive and carrier into the chassis drive bay.

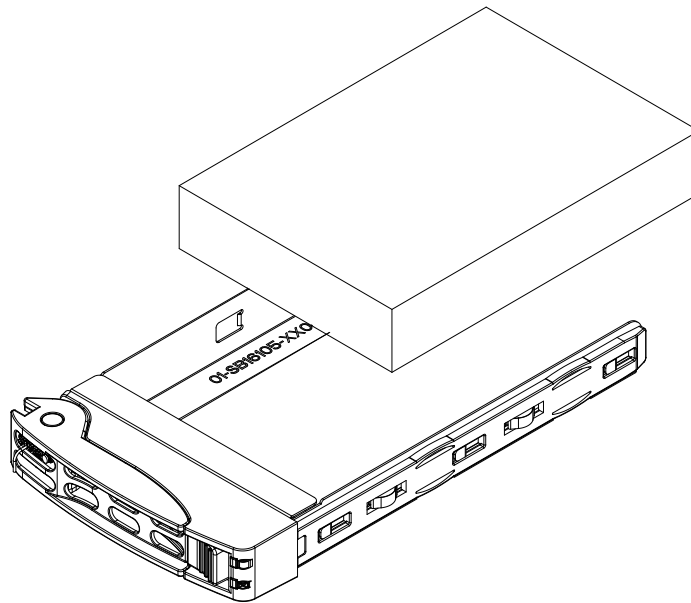

Figure 3-7. Installing a Drive into the Carrier

Air Shroud

The air shroud is used to concentrate airflow to maximize fan efficiency. The air shroud does not require screws to set up.

Installing the Air Shroud

1. Lay the chassis on a flat, stable surface and remove the chassis cover.
1. Make sure that the motherboard expansion card (if applicable) and all components are properly installed in each motherboard node.
2. If necessary, move any cables that interfere with the air shroud placement.
3. Place the air shroud in the chassis. The air shroud fits just behind the three fans in the fan rack. Slide the air shroud into the grooves just behind the fan rack.
4. Repeat the procedure for the remaining three motherboard nodes.
5. Reroute any cables that were moved and replace the chassis cover.

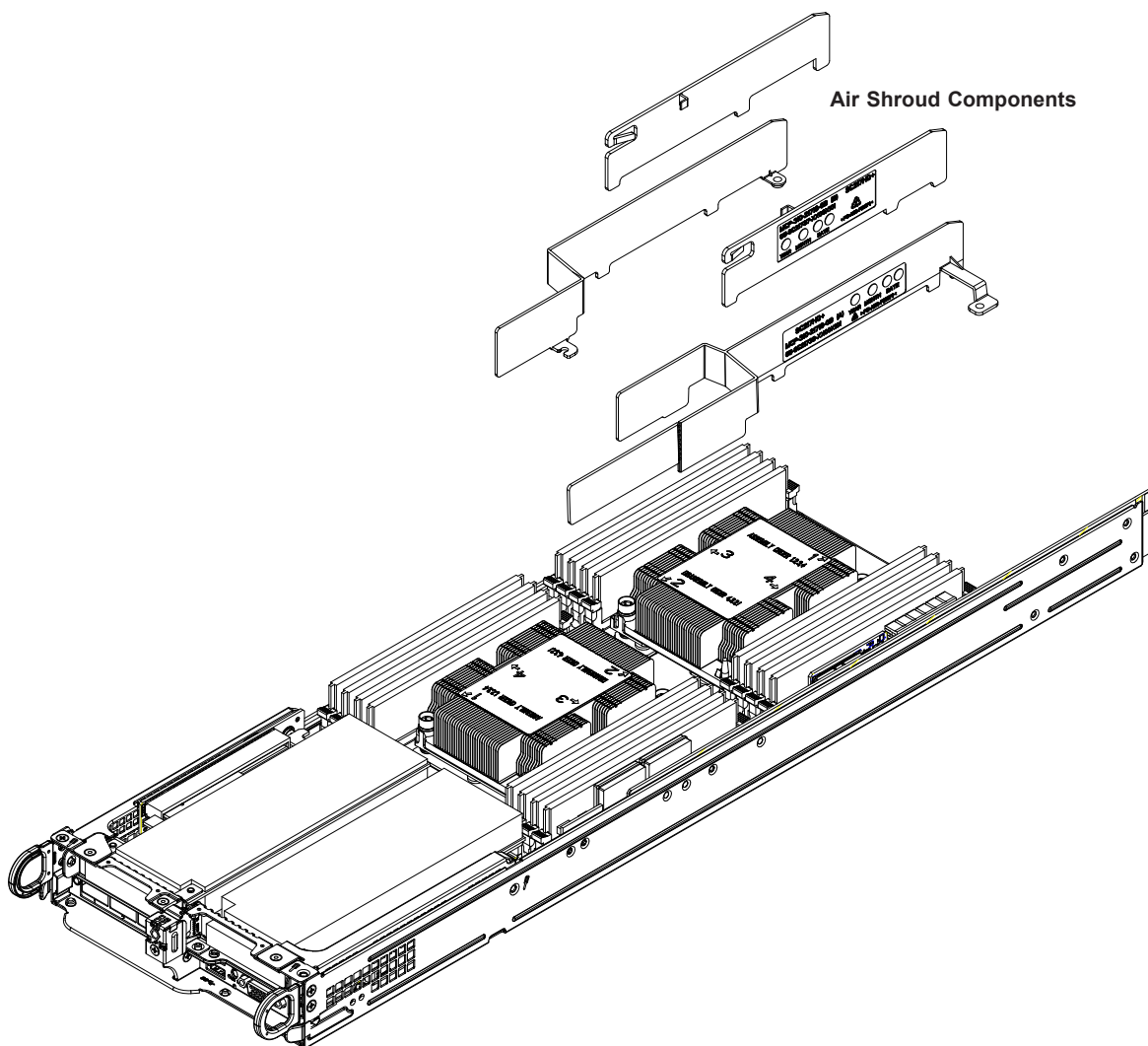

Figure 3-8. Installing the Air Shroud

Installing an Adapter Card

Adapter cards connect to the motherboard to the backplane and provide hot-swappable functionality to the node.

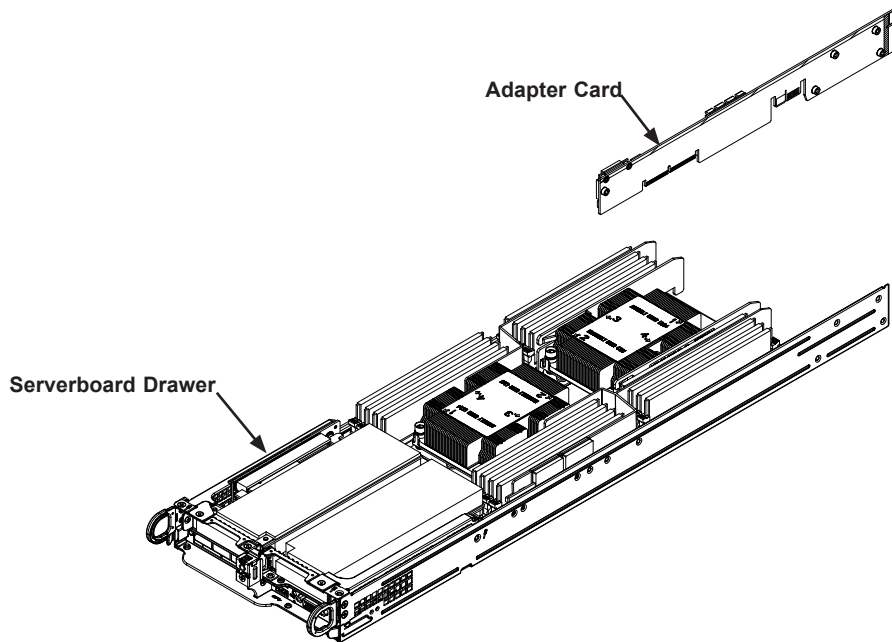

Figure 3-9. Adapter Card Installation

Removing the Adapter Card

1. Remove the node from the back of the chassis. It is not necessary to power down the system.
2. Disconnect the wiring, connecting the adapter card to the motherboard if any is present.
3. Remove the five screws securing the adapter card and the spacer plate to the drawer and set them aside for later use.
4. Remove the adapter card and spacer plate from the motherboard drawer.
5. Set the spacer plate aside for later use.

Installing the Adapter Card

1. Make sure the motherboard has been installed properly in the node drawer before installing the adapter card.
2. Place the adapter card and spacer plate in the node drawer, aligning the holes in the spacer and the adapter card with the holes in the drawer.
3. Secure the adapter card and spacer plate to the motherboard drawer, using the five M3 flathead screws which were previously set aside.
4. Reconnect the wiring from the motherboard to the adapter card if necessary.
5. Return the node drawer to the closed position in the chassis.

Installing the Riser Card

Installing the Riser Card

1. Use the control panel to power down the computing node, and pull the node drawer out of the chassis.
2. Remove the riser card bracket, removing the screw on the back of the drawer.
3. Align the riser card mounting hole to the bracket standoff and secure the riser card to the bracket using the two screws included in the accessory box.
4. Insert the riser card into the slot on the motherboard.
5. Secure the riser bracket to the rear of the node drawer.

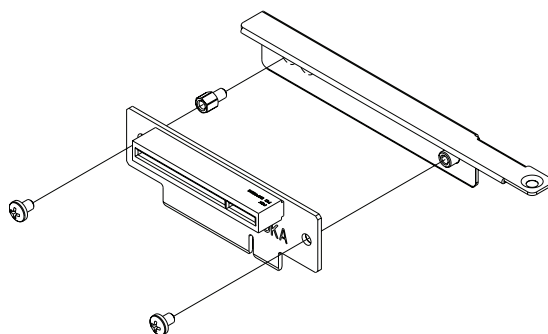

Figure 3-10. Installing the Riser Card

Installing Expansion Cards

1. Use the control panel to power down the computing node, and pull the node drawer out of the chassis.
2. Open the PCI slot clip in the rear of the node drawer and remove the PCI slot shield.
3. If the riser card is not already installed, push it into the motherboard slot.
4. Slide the expansion card into the riser card slot and fit the expansion card shield into the opening in the rear of the node drawer.
5. Close the PCI slot clip to secure the expansion card shield.
6. Secure the riser card screw.
7. Return the node drawer and power-up.

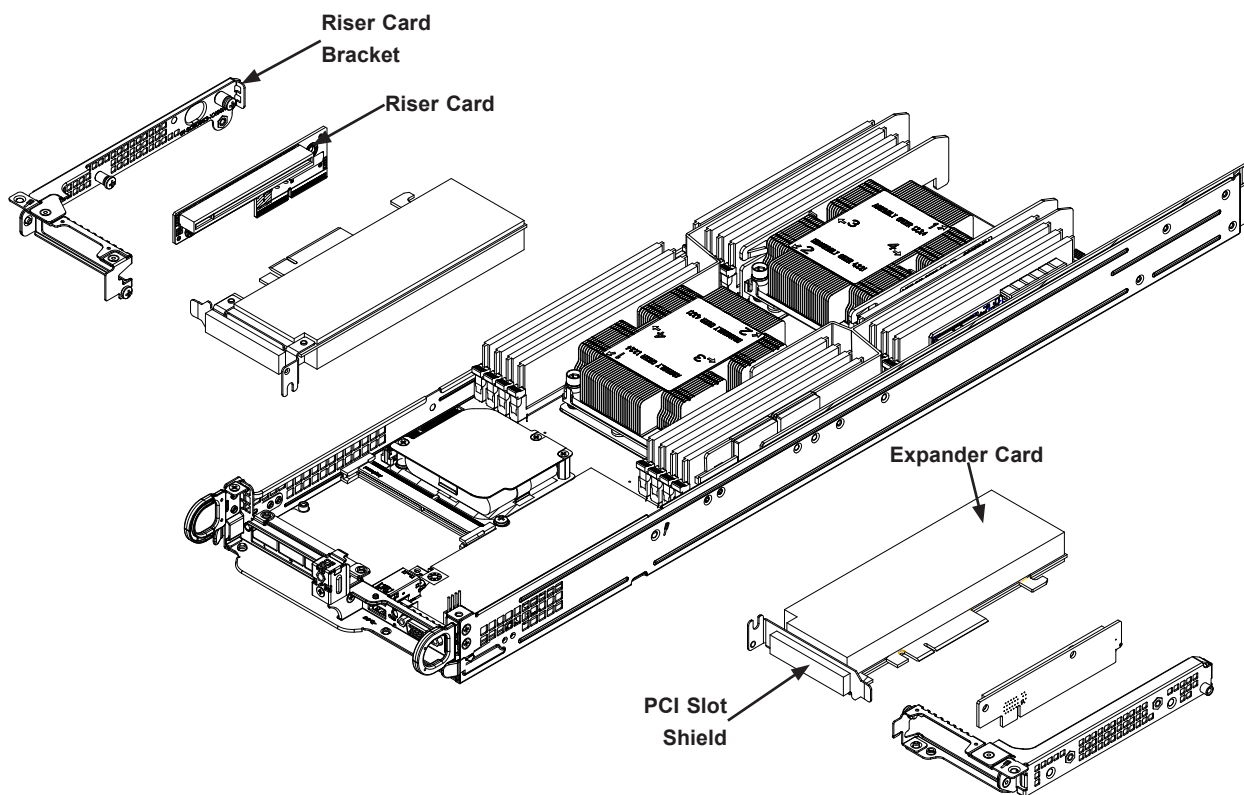

Figure 3-11. Installing the Expansion Card

SIOM Modules

In addition, the 2028TP-HTR/HC0R/HC1R was designed to accept one of four different SIOM modules (Supermicro I/O Module) to satisfy the specific I/O functions required by the system. The various SIOM modules are as follows:

- AOC-MGP-i2M: two RJ45 (1GbE) ports supported by an Intel i350-AM2 controller.
- AOC-MGP-i4M: four RJ45 (1GbE) ports supported by an Intel i350-AM4 controller.
- AOC-MTGN-i2SM: two SFP+ (10GbE) ports supported by an Intel 82599ES controller.
- AOC-MTGN-i4SM: four SFP+ (10GbE) ports supported by an Intel XL710-BM1 controller.
- AOC-MTG-i2TM: two RJ45 (10GbE) ports supported by an Intel X550 controller
- AOC-MTG-i2TM: two RJ45 (10GbE) ports supported by an Intel X550 controller
- AOC-MHIBF-m2Q2GM: two RJ45 (40GbE) supported by an Intel i350 controller, and two QSFP (56GbE) supported by an Mellanox® ConnectX-3 Pro InfiniBand FDR controller
- AOC-MHIBF-m1Q2GM: two RJ45 (40GbE) supported by an Intel i350 controller, and one QSFP (56GbE) supported by an Mellanox® ConnectX-3 Pro InfiniBand FDR controller

Installing a SIOM Module into the Chassis

1. Take out the five screws securing the two front riser brackets in the chassis.
2. Remove the two screws from the Pulling Ear and one screw from the side of the SIOM mounting bracket.
3. Flip the chassis and take out the two screws securing the sled back.
4. Flip back the chassis upward and take out the SIOM bracket.

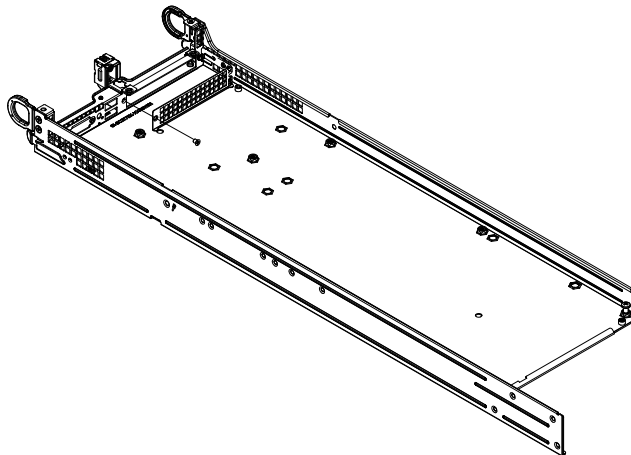

Figure 3-12. Removing the Front Riser Brackets and Pulling Ear

5. Remove the two screws holding the SIOM module and carefully remove the module out of the chassis.
6. Replace with the new SIOM module desired and put the SIOM bracket back in place. Secure the bracket with its two screws (from step 5) using about 3-pounds of torque and a slow speed (if using a power tool) or manually using a screwdriver.
7. Flip the chassis and secure the sled back using its two screws (from step 3).
8. Put the Pulling Ear back in place and secure it using its screw at the SIOM mounting bracket (from step 2).
9. Replace the five screws securing the two riser brackets (from step 1).

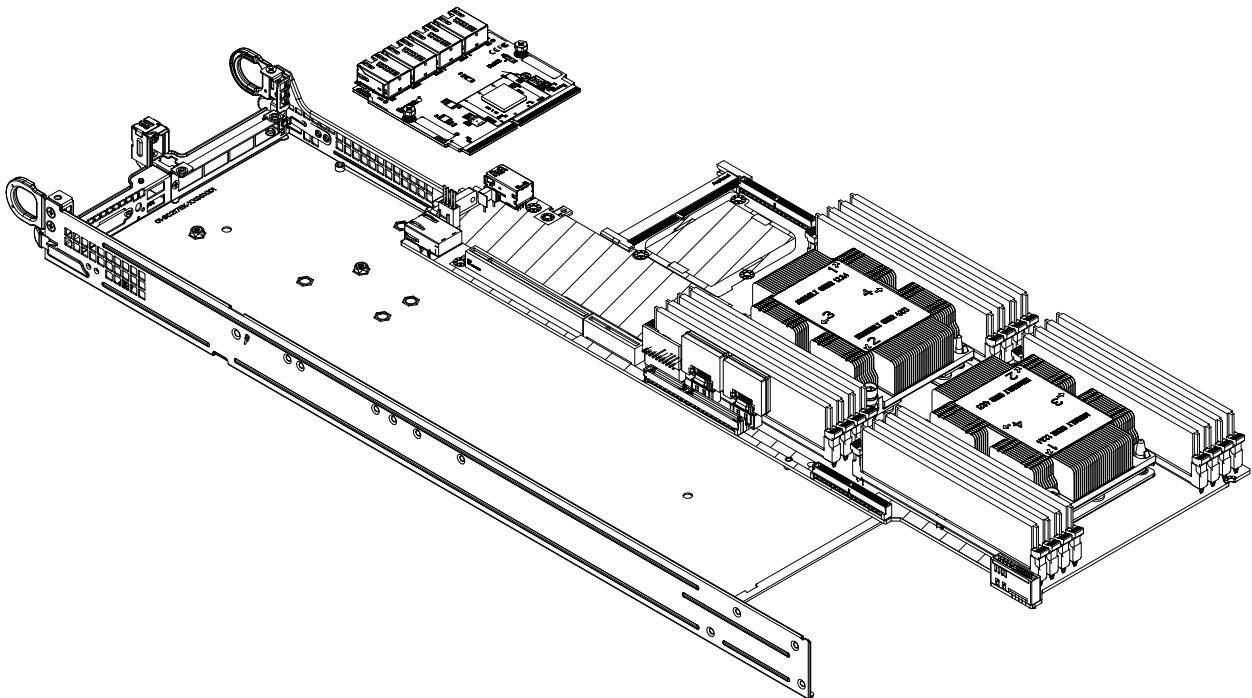

Figure 3-13. Installing the SIOM Module

System Fans

Six hot-swappable fans provide cooling from the middle of the chassis.

Replacing a System Fan

1. Use IPMI or another monitoring tool, if available, to determine which fan has failed.
2. Open the chassis cover. If a monitoring tool is not available, observe which fan has failed. (Never run the server for an extended period of time with the chassis cover open.)
3. Remove the failed fan's power cord from the motherboard.
4. Press the fan release tab to lift the failed fan from the chassis and pull it completely out of the chassis.
5. Place the new fan into the vacant space in the housing while making sure the arrows on the top of the fan (indicating airflow direction) point in the same direction as the arrows on the other fans.
6. Check that the fan is working properly before replacing the chassis cover.

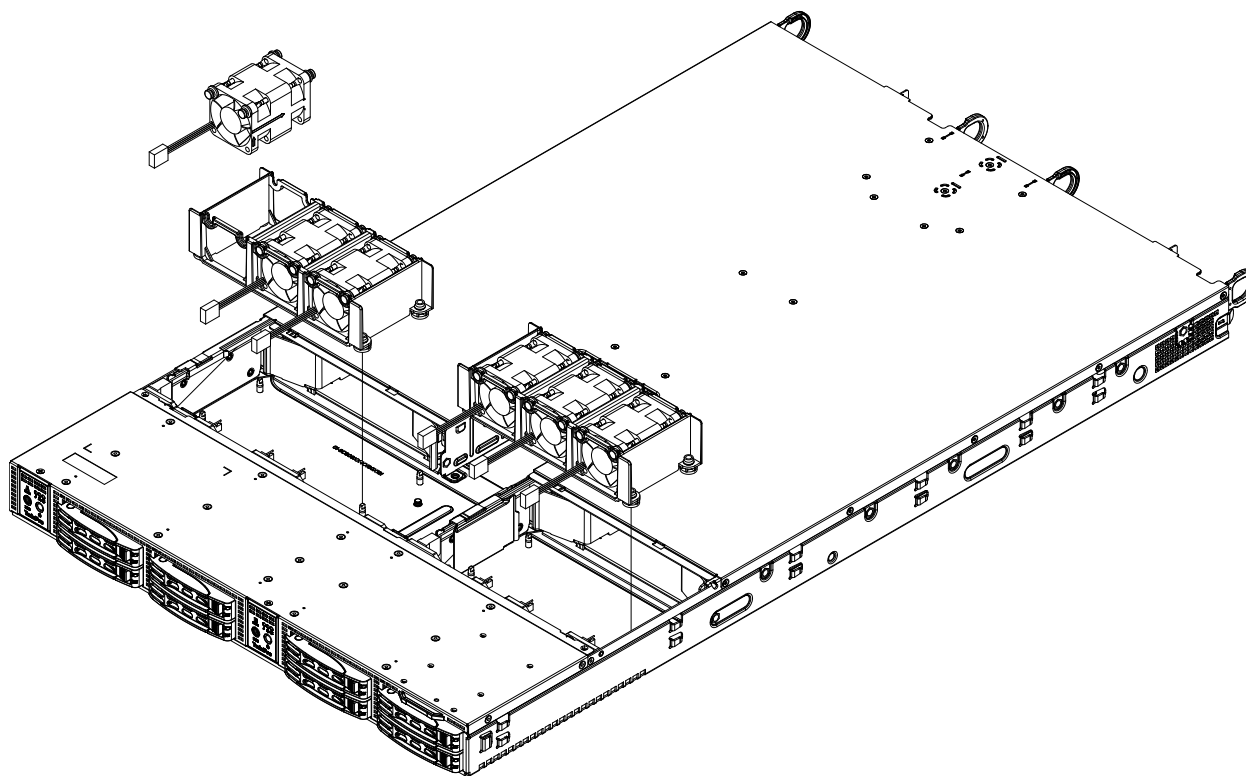

Figure 3-14. Replacing a Fan

Power Supply

The chassis features redundant power supplies. They are hot-swappable, meaning they can be changed without powering down the system. New units can be ordered directly from Supermicro or authorized distributors.

These power supplies are auto-switching capable. This feature enables them to automatically sense the input voltage and operate at a 100-120v or 180-240v. An amber light will be illuminated on the power supply when the power is off. An illuminated green light indicates that the power supply is operating.

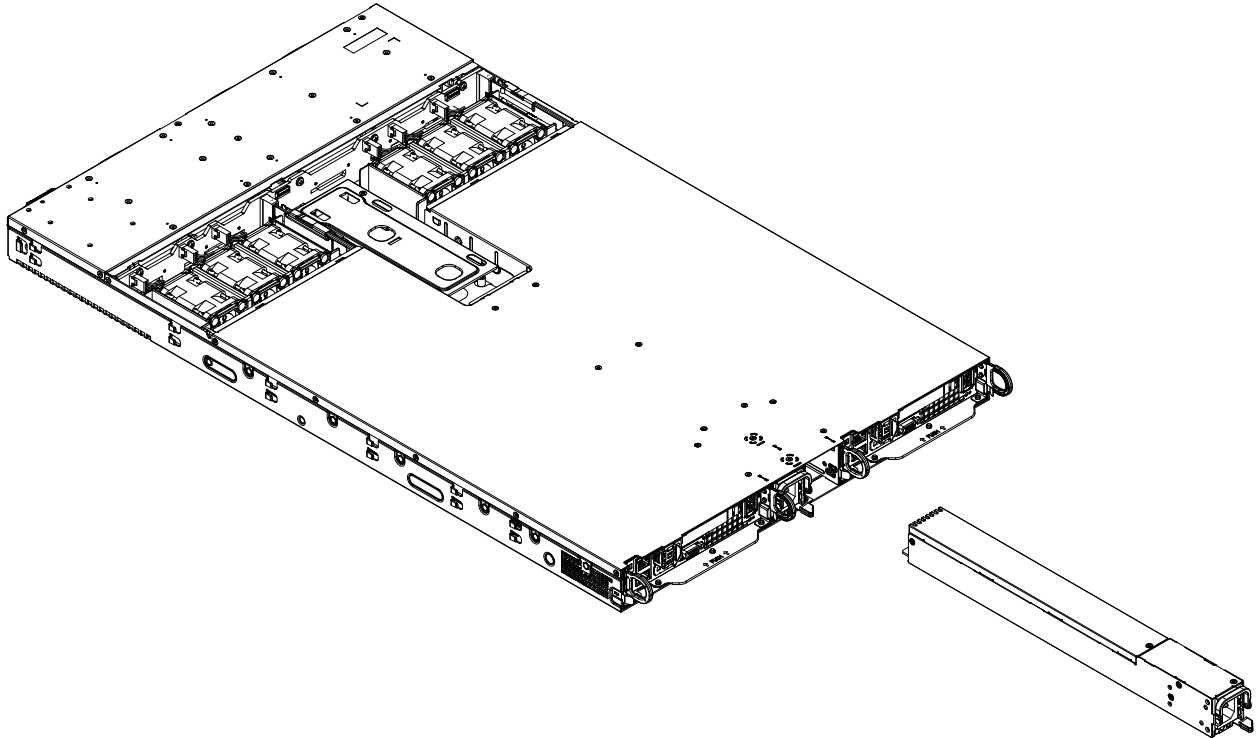

Figure 3-15. Power Supply Module

Changing the Power Supply:

1. Unplug the AC cord from the module to be replaced.
2. Push the release tab on the back of the power supply as illustrated.

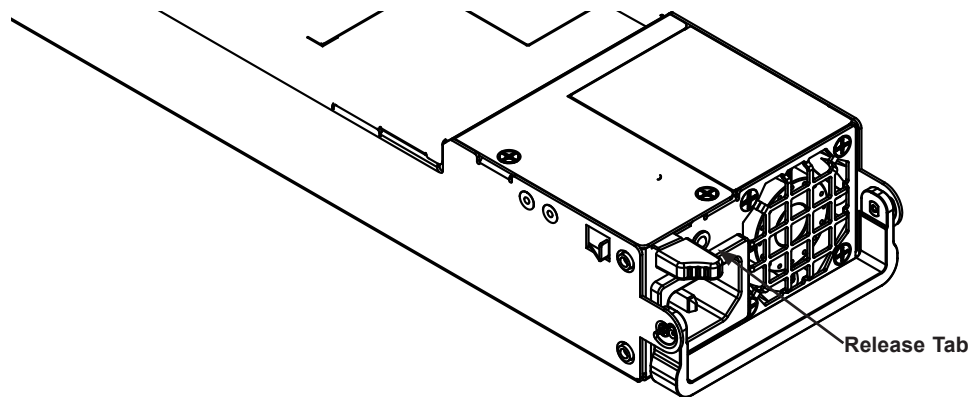

Figure 3-16. Power Supply Release Tab

3. Pull the power supply out using the handle provided.
4. Replace the failed power module with the same model.
5. Push the new power supply module into the power bay until it clicks.
6. Plug the AC power cord back into the module.

Chapter 4

Motherboard Connections

This section describes the connections on the motherboard and provides pinout definitions. Note that depending on how the system is configured, not all connections are required. The LEDs on the motherboard are also described here. A serverboard layout indicating component locations may be found in Chapter 1.

Please review the Safety Precautions in Chapter 3 before installing or removing components.

4.1 Power Connections

SMCI-Proprietary Power Connector

An SMCI-proprietary power connector is located at JHS1 on the motherboard. Connect an appropriate power cable here to provide adequate power to your system.

4.2 Headers and Connectors

Onboard Fan Header

An onboard fan header (FAN3) is located next to COM port (COM1) on the motherboard. This is a 4-pin fan header, which is backward compatible with a traditional 3-pin fan. The onboard fan speed is controlled by Thermal Management (via Hardware Monitoring) in the BIOS. When using Thermal Management setting, please use all 3-pin fans or all 4-pin fans.

Fan Header Pin Definitions	
Pin#	Definition
1	Ground (Black)
2	+12V (Red)
3	Tachometer
4	PWM Control

RAID Key Header

A RAID_Key header is located at JRK1 on the motherboard. RAID key is used to support NVMe SSD.

RAID Key Header Pin Definitions	
Pin#	Definition
1	Ground
2	P3V3_STBY (RAID_KEY_PU)
3	Ground
4	P3V3_STBY (RAID_KEY)

TPM Header

The JTPM1 header is used to connect a Trusted Platform Module (TPM)/Port 80, which is available from a third-party vendor. The TPM/Port 80 connector is a security device that supports encryption and authentication in hard drives. It allows the motherboard to deny access if the TPM associated with the hard drive is not installed in the system. See the table below for pin definitions.

Trusted Platform Module/Port 80 Header Pin Definitions			
Pin#	Definition	Pin#	Definition
1	P3V3	2	SPI_TPM_CS_N
3	PCI_RESET_N	4	SPI_PCH_MISO
5	SPI_PCH_CLK	6	Ground
7	SPI_PCH_MOSI	8	x
9	P3V3_STBY	10	P3V3_STBY

I-SATA 3.0 and S-SATA 3.0 Ports

The X11DPT-PS has six I-SATA 3.0 ports (I-SATA0-3, I-SATA4/I-SATA5) and six S-SATA (S-SATA0-5) on the motherboard. These SATA ports are supported by the Intel C621 chipset. I-SATA0-3 are supported by CPU2 PCI-E 3.0 x16 slot on SXB2, and S-SATA0-5 are supported by the CPU1 PCI-E 3.0 x8 slot on SXB1. I-SATA4/ I-SATA5 can be used with Supermicro SuperDOMs, which are yellow SATA DOM connectors with power pins built in, and do not require external power cables. Supermicro SuperDOMs are backward-compatible with regular SATA HDDs or SATA DOMs that need external power cables.

SATA 3.0 Port Pin Definitions	
Pin#	Signal
1	Ground
2	SATA_TXP
3	SATA_TXN
4	Ground
5	SATA_RXN
6	SATA_RXP
7	Ground

VGA Port

The onboard VGA port is located next to IPMI_LAN on the I/O back panel. Use this connection for VGA display.

Serial Port

A COM port (COM1) is located next to the VGA port on the motherboard. This COM port provides serial communication support. See the table below for pin definitions.

COM Port Pin Definitions			
Pin#	Definition	Pin#	Definition
1	DCD	6	DSR
2	RXD	7	RTS
3	TXD	8	CTS
4	DTR	9	RI
5	Ground	10	N/A

Universal Serial Bus (USB) Ports

Two USB 3.0 port (USB0/1) are located on the I/O back panel. Connect appropriate cables here to use USB support. (USB cables are not included).

Back Panel USB (3.0) Pin Definitions			
Pin#	Definition	Pin#	Definition
1	VBUS	10	Power
2	D-	11	USB 2.0 Differential Pair
3	D+	12	
4	Ground	13	Ground of PWR Return
5	StdA_SSRX-	14	SuperSpeed Receiver
6	StdA_SSRX+	15	Differential Pair
7	GND_DRAIN	16	Ground for Signal Return
8	StdA_SSTX-	17	SuperSpeed Transmitter
9	StdA_SSTX+	18	Differential Pair

Unit Identifier Switch/UID LED Indicator

A Unit Identifier (UID) switch (JUIDB1) and a UID LED Indicator (UID_LED1) are located on the rear side of the system. When you press the UID switch, the UID LED indicator will be turned on. Press the UID switch again to turn off the LED. The UID Indicator provides easy identification of a system unit that may be in need of service.

Note: UID can also be triggered via IPMI on the motherboard. For more information on IPMI, please refer to the IPMI User's Guide posted on our website at <http://www.supermicro.com>.

UID Switch Pin Definitions	
Pin#	Definition
1	Ground
2	Ground
3	Button In
4	Button In

UID LED Pin Definitions	
Color	Status
Blue: On	Unit Identified

Ethernet Ports

An Dedicated IPMI LAN that supports Gigabit LAN is located next to the VGA port on the I/O back panel. This LAN port is supported by the onboard AST 2500 BMC and accepts an RJ45 type cable. Refer to the LED Indicator Section for LAN LED information.

4.4 Jumpers

Explanation of Jumpers

To modify the operation of the motherboard, jumpers are used to choose between optional settings. Jumpers create shorts between two pins to change the function associated with it. Pin 1 is identified with a square solder pad on the printed circuit board. See the motherboard layout page for jumper locations.

Note: On a two-pin jumper, "Closed" means the jumper is on both pins and "Open" indicates the jumper is either on only one pin or has been completely removed.

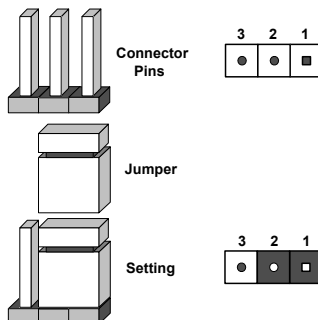

CMOS Clear

JBT1 is used to clear CMOS, which will also clear any passwords. Instead of pins, this jumper consists of contact pads to prevent accidentally clearing the contents of CMOS.

To Clear CMOS

1. First power down the system and unplug the power cord(s).
2. Remove the cover of the chassis to access the motherboard.
3. Remove the onboard battery from the motherboard.
4. Short the CMOS pads with a metal object such as a small screwdriver for at least four seconds.
5. Remove the screwdriver (or shorting device).
6. Replace the cover, reconnect the power cord(s) and power on the system.

Notes: Clearing CMOS will also clear all passwords.

Do not use the PW_ON connector to clear CMOS.



Manufacturing Mode Select

Close JPME1 to bypass SPI flash security and force the system to use the Manufacturing Mode, which will allow you to flash the system firmware from a host server to modify system settings. See the table below for jumper settings.

Manufacturing Mode Select Jumper Settings	
Jumper Setting	Definition
Pins 1-2	Normal (Default)
Pins 2-3	Manufacturing Mode

Watch Dog

JWD1 controls the Watch Dog function. Watch Dog is a monitor that can reboot the system when a software application hangs. Jumping pins 1-2 will cause Watch Dog to reset the system if an application hangs. Jumping pins 2-3 will generate a non-maskable interrupt signal for the application that hangs. Watch Dog must also be enabled in BIOS. The default setting is Reset.

Note: When Watch Dog is enabled, the user needs to write their own application software to disable it.

Watch Dog Jumper Settings	
Jumper Setting	Definition
Pins 1-2	Reset
Pins 2-3	NMI
Open	Disabled

4.5 LED Indicators

LAN LEDs

Two LAN ports (LAN 1 and LAN 2) are located on the I/O back panel of the motherboard. Each Ethernet LAN port has two LEDs. The green LED indicates activity, while the other Link LED may be green, amber, or off to indicate the speed of the connection. Refer to the tables below for more information.

LAN1/2 Activity LED (Right) LED State			LAN1/2 Link LED (Left) LED State	
Color	Status	Definition	LED Color	Definition
Green	Flashing	Active	Green	10Gbps
			Yellow/Amber	1Gbps

Dedicated IPMI LAN LEDs

In addition to LAN1 and LAN2, an IPMI LAN is also located on the I/O back panel. The amber LED on the right of the IPMI LAN port indicates activity, while the green LED on the left indicates the speed of the connection. See the table below for more information.

IPMI LAN LEDs		
LED	Color/State	Definition
Link (left)	Green: Solid	100 Mb/s
	Amber: Solid	1Gbps
Activity (right)	Amber: Blinking	Active



BMC Heartbeat LED

BMC_HB_LED is the BMC heartbeat LED. When the LED is blinking green, BMC is functioning normally. See the table below for the LED status.

BMC Heartbeat LED Indicator	
LED Color	Definition
Green: Blinking	BMC Normal

HDD LED

The HDD LED connection is located on the motherboard. Refer to the table below for pin definitions.

HDD LED Pin Definitions (JF1)	
Pins	Definition
13	3.3V Stdby
14	HDD Active

Chapter 5

Software

After the hardware has been installed, you can install the Operating System (OS), configure RAID settings and install the drivers.

5.1 Microsoft Windows OS Installation

If you will be using RAID, you must configure RAID settings before installing the Windows OS and the RAID driver. Refer to the RAID Configuration User Guides posted on our website at www.supernmicro.com/support/manuals.

Installing the OS

1. Create a method to access the MS Windows installation ISO file. That might be a DVD, perhaps using an external USB/SATA DVD drive, or a USB flash drive, or the IPMI KVM console.
2. Retrieve the proper RST/RSTe driver. Go to the Supermicro web page for your motherboard and click on "Download the Latest Drivers and Utilities", select the proper driver, and copy it to a USB flash drive.
3. Boot from a bootable device with Windows OS installation. You can see a bootable device list by pressing **F11** during the system startup.

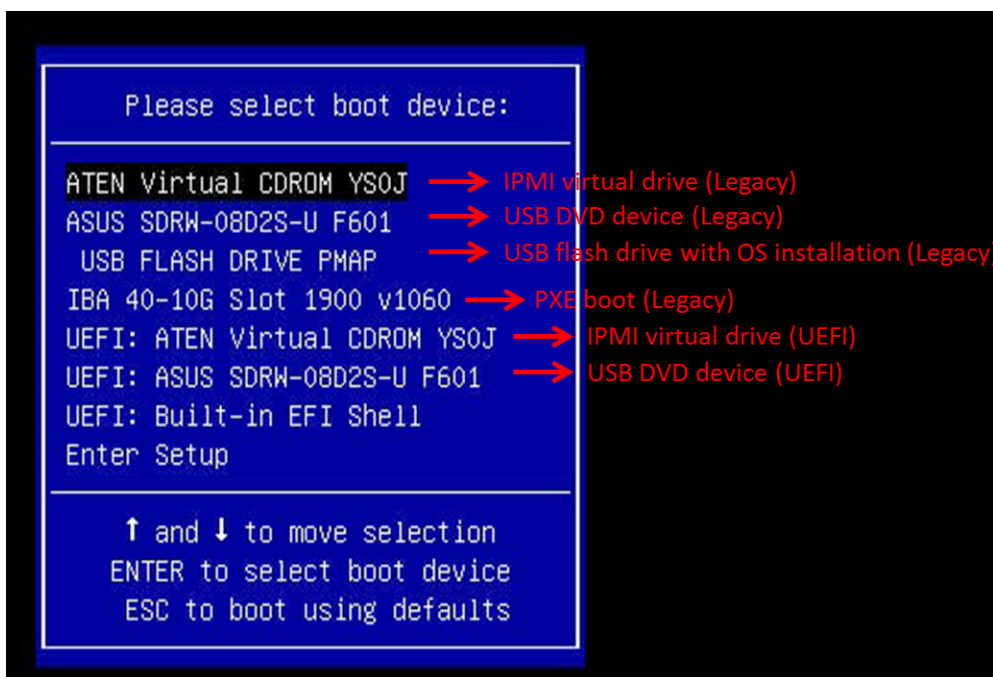

Figure 5-1. Select Boot Device

4. During Windows Setup, continue to the dialog where you select the drives on which to install Windows. If the disk you want to use is not listed, click on “Load driver” link at the bottom left corner.

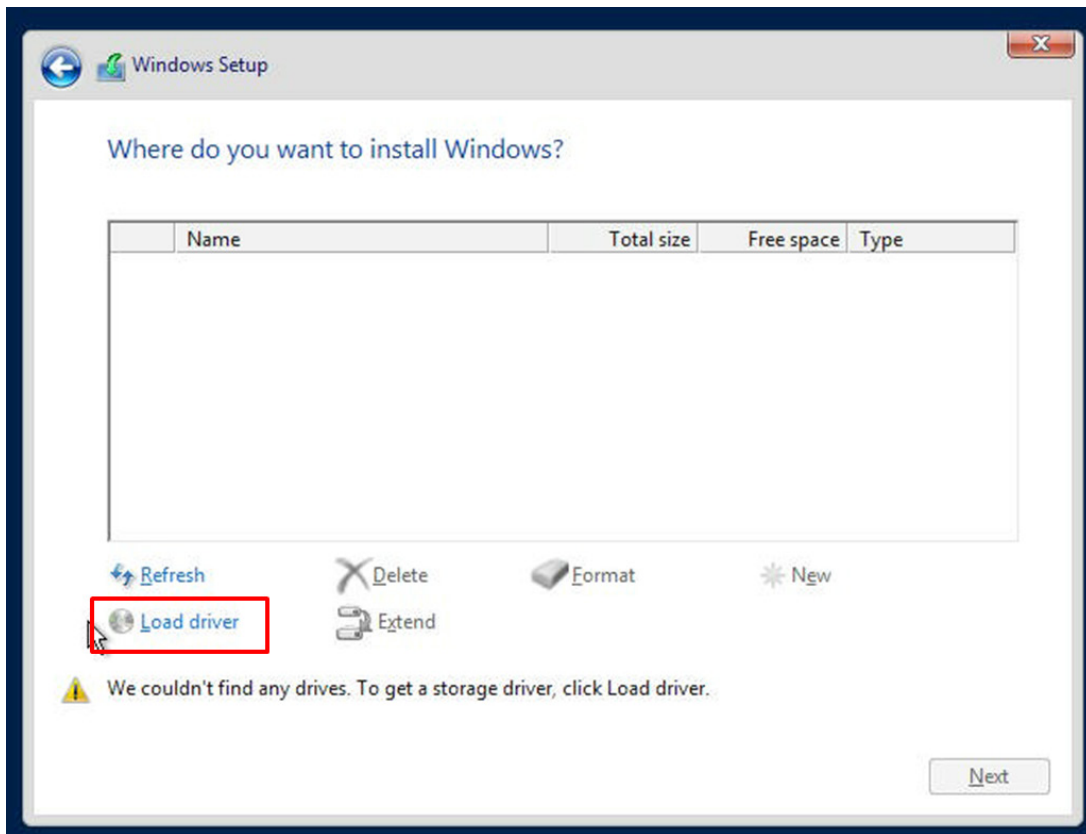

Figure 5-2. Load Driver Link

To load the driver, browse the USB flash drive for the proper driver files.

- For RAID, choose the SATA/sSATA RAID driver indicated then choose the storage drive on which you want to install it.
 - For non-RAID, choose the SATA/sSATA AHCI driver indicated then choose the storage drive on which you want to install it.
5. Once all devices are specified, continue with the installation.
 6. After the Windows OS installation has completed, the system will automatically reboot multiple times.

5.2 Driver Installation

The Supermicro website contains drivers and utilities for your system at <https://www.supermicro.com/wftp/driver>. Some of these must be installed, such as the chipset driver.

After accessing the website, go into the CDR_Images (in the parent directory of the above link) and locate the ISO file for your motherboard. Download this file to a USB flash drive or a DVD. (You may also use a utility to extract the ISO file if preferred.)

Another option is to go to the Supermicro website at <http://www.supermicro.com/products/>. Find the product page for your motherboard, and "Download the Latest Drivers and Utilities".

Insert the flash drive or disk and the screenshot shown below should appear.

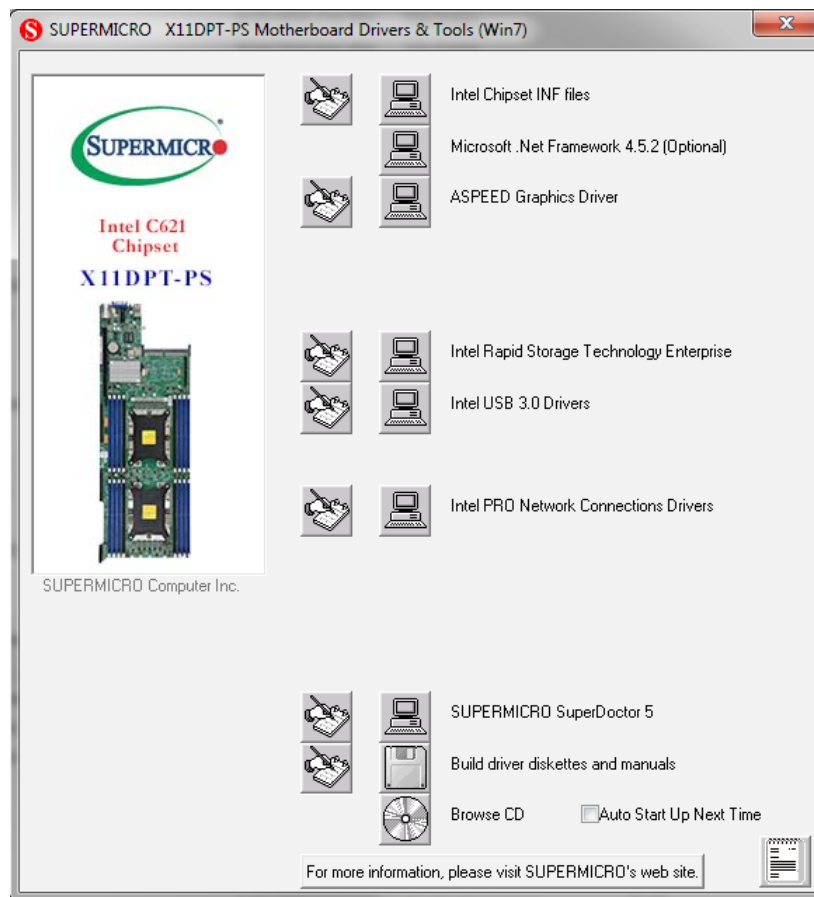

Figure 5-3. Driver & Tool Installation Screen

Note: Click the icons showing a hand writing on paper to view the readme files for each item. Click the computer icons to the right of these items to install each item (from top to the bottom) one at a time. **After installing each item, you must re-boot the system before moving on to the next item on the list.** The bottom icon with a CD on it allows you to view the entire contents.

5.3 SuperDoctor® 5

The Supermicro SuperDoctor 5 is a program that functions in a command-line or web-based interface for Windows and Linux operating systems. The program monitors such system health information as CPU temperature, system voltages, system power consumption, fan speed, and provides alerts via email or Simple Network Management Protocol (SNMP).

SuperDoctor 5 comes in local and remote management versions and can be used with Nagios to maximize your system monitoring needs. With SuperDoctor 5 Management Server (SSM Server), you can remotely control power on/off and reset chassis intrusion for multiple systems with SuperDoctor 5 or IPMI. SuperDoctor 5 Management Server monitors HTTP, FTP, and SMTP services to optimize the efficiency of your operation.

Note: The default User Name and Password for SuperDoctor 5 is ADMIN / ADMIN.

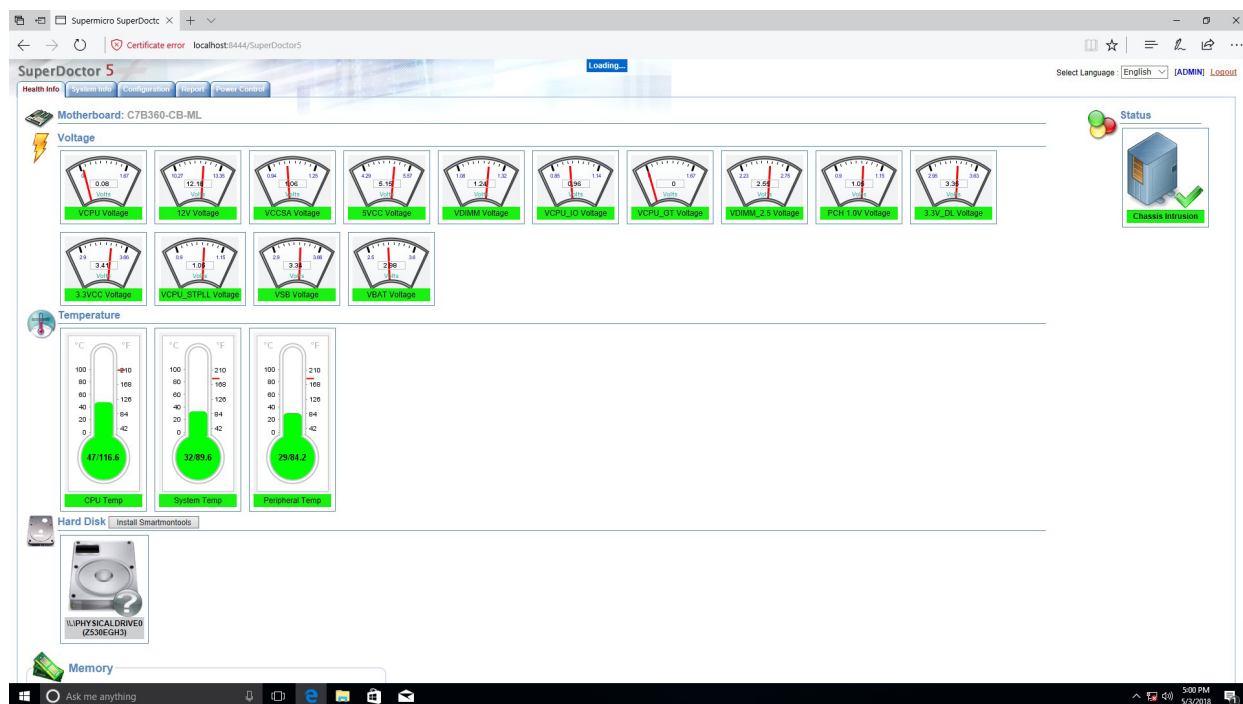

Figure 5-4. SuperDoctor 5 Interface Display Screen (Health Information)

5.4 IPMI

The X11DPT-PS supports the Intelligent Platform Management Interface (IPMI). IPMI is used to provide remote access, monitoring and management. There are several BIOS settings that are related to IPMI.

For general documentation and information on IPMI, please visit our website at: <http://www.supermicro.com/products/nfo/IPMI.cfm>.

Chapter 6

UEFI BIOS

6.1 Introduction

This chapter describes the AMIBIOS™ Setup utility for the X11DPT-PS X11DPT-PS motherboard. The BIOS is stored on a chip and can be easily upgraded using a flash program.

Note: Due to periodic changes to the BIOS, some settings may have been added or deleted and might not yet be recorded in this manual. Please refer to the Manual Download area of our website for any changes to BIOS that may not be reflected in this manual.

Starting the Setup Utility

To enter the BIOS setup utility, press the <Delete> key while the system is booting up. (In most cases, the <Delete> key is used to invoke the BIOS setup screen. There are a few cases when other keys are used, such as <F1>, <F2>, etc.) Each main BIOS menu option is described in this manual.

The Main BIOS screen has two main frames. The left frame displays all the options that can be configured. “Grayed-out” options cannot be configured. The right frame displays the key legend. Above the key legend is an area reserved for a text message. When an option is selected in the left frame, it is highlighted in white. Often a text message will accompany it. (Note that BIOS has default text messages built in. We retain the option to include, omit, or change any of these text messages.) Settings printed in **Bold** are the default values.

A "►" indicates a submenu. Highlighting such an item and pressing the <Enter> key will open the list of settings within that submenu.

The BIOS setup utility uses a key-based navigation system called hot keys. Most of these hot keys (<F1>, <F10>, <Enter>, <ESC>, <Arrow> keys, etc.) can be used at any time during the setup navigation process.

6.2 Main Setup

When you first enter the AMI BIOS setup utility, you will enter the Main setup screen. You can always return to the Main setup screen by selecting the Main tab on the top of the screen. The Main BIOS setup screen is shown below. The following Main menu items will be displayed:



System Date/System Time

Use this feature to change the system date and time. Highlight *System Date* or *System Time* using the arrow keys on the keyboard. Press the <Tab> key or the arrow keys to move between fields. The date must be entered in Day MM/DD/YYYY format. The time is entered in HH:MM:SS format.

Note: The time is in the 24-hour format. For example, 5:30 P.M. appears as 17:30:00. The date's default value is 01/01/2014 after RTC reset.

Supermicro X11DPT-PS

BIOS Version

This item displays the version of the BIOS ROM used in the system.

Build Date

This item displays the date when the version of the BIOS ROM used in the system was built.

CPLD Version

This item displays the version of the CPLD (Complex-Programmable Logical Device) used in the system.

Memory Information**Total Memory**

This item displays the total size of memory available in the system.

Memory Speed

This item displays the default speed of the memory modules installed in the system.

6.3 Advanced Setup Configurations

Use the arrow keys to select the Advanced submenu and press <Enter> to access the submenu items:

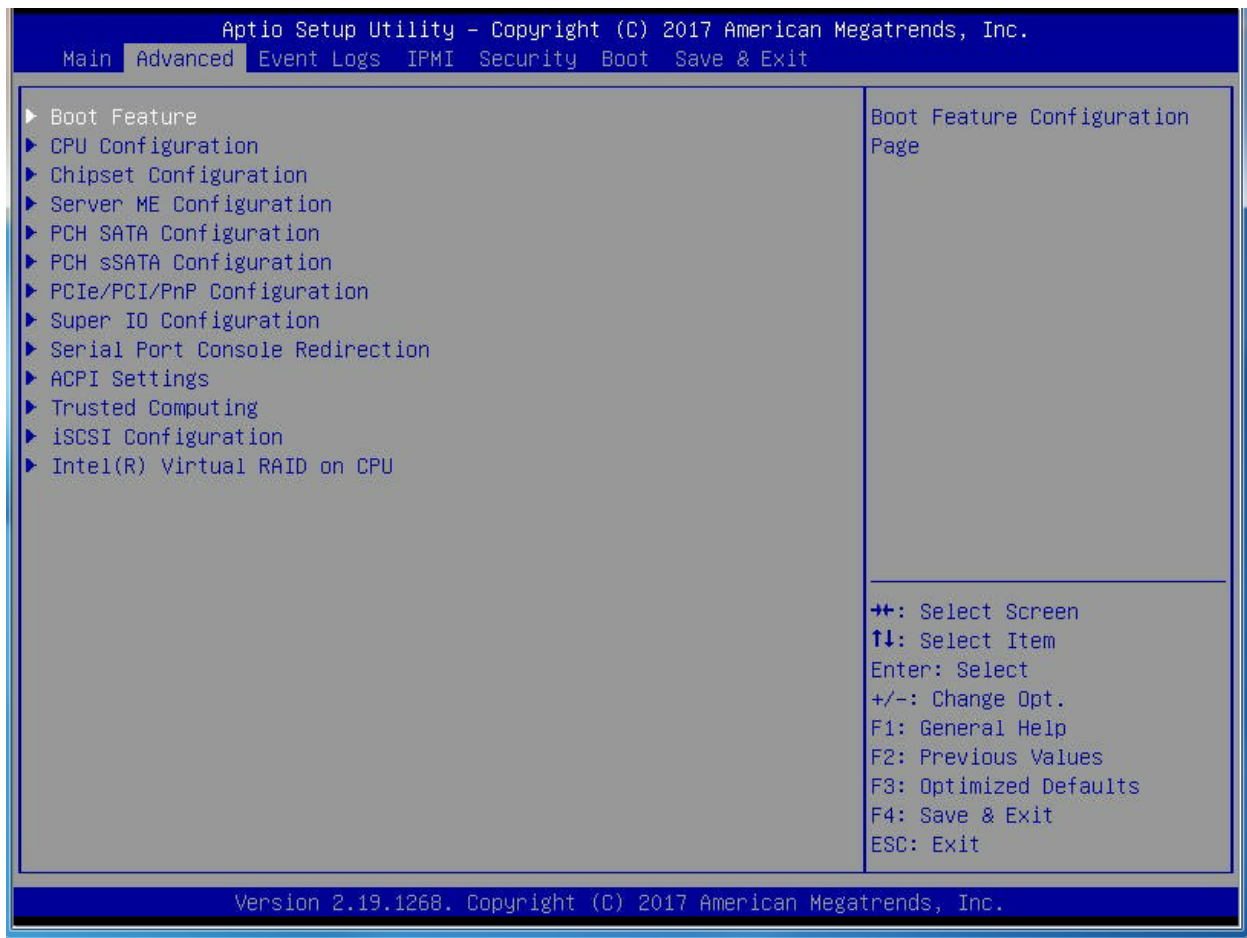

Warning: Take Caution when changing the Advanced settings. An incorrect value, an incorrect DRAM frequency, or an incorrect BIOS timing setting may cause the system to malfunction. When this occurs, restore the setting to the manufacture default setting.

► Boot Feature

Quiet Boot

Use this feature to select the screen between displaying POST messages or the OEM logo at bootup. Select Disabled to display the POST messages. Select Enabled to display the OEM logo instead of the normal POST messages. The options are **Enabled** and Disabled.

Note: POST message is always displayed regardless of the item setting.

Option ROM Messages

Use this feature to set the display mode for the Option ROM. Select Keep Current to use the current AddOn ROM display setting. Select Force BIOS to use the Option ROM display mode set by the system BIOS. The options are **Force BIOS** and Keep Current.

Bootup NumLock State

Use this feature to set the Power-on state for the Numlock key. The options are Off and **On**.

Wait For 'F1' If Error

Select Enabled to force the system to wait until the 'F1' key is pressed if an error occurs. The options are Disabled and **Enabled**.

INT19 Trap Response

Interrupt 19 is the software interrupt that handles the boot disk function. When this item is set to Immediate, the ROM BIOS of the host adaptors will "capture" Interrupt 19 at bootup immediately and allow the drives that are attached to these host adaptors to function as bootable disks. If this item is set to Postponed, the ROM BIOS of the host adaptors will not capture Interrupt 19 immediately and allow the drives attached to these adaptors to function as bootable devices at bootup. The options are **Immediate** and Postponed.

Re-try Boot

When EFI (Expansible Firmware Interface) Boot is selected, the system BIOS will automatically reboot the system from an EFI boot device after an initial boot failure. Select Legacy Boot to allow the BIOS to automatically reboot the system from a Legacy boot device after an initial boot failure. The options are **Disabled**, Legacy Boot, and EFI Boot.

Install Windows 7 USB Support

Select Enabled to install Windows 7 and the XHCI drivers for USB keyboard/mouse support. After you've installed the Windows 7 and XHCI drivers, be sure to set this feature to "Disabled" (default). The options are **Disabled** and Enabled.

Port 61h Bit-4 Emulation

Select Enabled for I/O Port 61h-Bit 4 emulation support to enhance system performance. The options are Enabled and **Disabled**.

Power Configuration**Watch Dog Function**

Select Enabled to allow the Watch Dog timer to reboot the system when it is inactive for more than 5 minutes. The options are Enabled and **Disabled**.

Restore on AC Power Loss

Use this feature to set the power state after a power outage. Select Power-Off for the system power to remain off after a power loss. Select Power-On for the system power to be turned on after a power loss. Select Last State to allow the system to resume its last power state before a power loss. The options are Power-On, Stay-Off and **Last State**.

Power Button Function

This feature controls how the system shuts down when the power button is pressed. Select 4 Seconds Override for the user to power off the system after pressing and holding the power button for 4 seconds or longer. Select Instant Off to instantly power off the system as soon as the user presses the power button. The options are 4 Seconds Override and **Instant Off**.

Throttle on Power Fail

Select Enabled to decrease system power input by throttling CPU frequency when the power supply fails. The options are Enabled and **Disabled**.

►CPU Configuration

Warning: Setting the wrong values in the following sections may cause the system to malfunction.

►Processor Configuration

The following CPU information will be displayed:

- Processor BSP Revision
- Processor Socket
- Processor ID
- Processor Frequency
- Processor Max Ratio
- Processor Min Ratio
- Microcode Revision
- L1 Cache RAM
- L2 Cache RAM
- L3 Cache RAM
- Processor 0 Version
- Processor 1 Version

Hyper-Threading (ALL)

Select Enable to use Intel Hyper-Threading Technology to enhance CPU performance. The options are **Enable** and Disable.

Execute Disable Bit (Available if supported by the OS & the CPU)

Select Enable to enable Execute Disable Bit support which will allow the processor to designate areas in the system memory where an application code can execute and where it cannot, thus preventing a worm or a virus from flooding illegal codes to overwhelm the processor, damaging the system during a virus attack. The options are **Enable** and Disable. (Refer to Intel and Microsoft websites for more information.)

Intel Virtualization Technology

Select Enable to use Intel Virtualization Technology which will allow the I/O device assignments to be directly reported to the VMM (Virtual Memory Management) through the DMAR ACPI tables. This feature offers fully-protected I/O resource-sharing across the Intel platforms, providing the user with greater reliability, security and availability in networking and data-sharing. The settings are **Enable** and Disable.

PPIN Control

Select Unlock/Enable to use the Protected-Processor Inventory Number (PPIN) in the system. The options are **Unlock/Enable** and Unlock/Disable.

Hardware Prefetcher (Available when supported by the CPU)

If this feature is set to Enable, the hardware prefetcher will prefetch streams of data and instructions from the main memory to the Level 2 (L2) cache to improve CPU performance. The options are Disable and **Enable**.

Adjacent Cache Prefetch (Available when supported by the CPU)

Select Enable for the CPU to prefetch both cache lines for 128 bytes as comprised. Select Disable for the CPU to prefetch both cache lines for 64 bytes. The options are Disable and **Enable**.

Note: Please power off and reboot the system for the changes you've made to take effect. Please refer to Intel's website for detailed information.

DCU Streamer Prefetcher (Available when supported by the CPU)

If this feature is set to Enable, the DCU (Data Cache Unit) streamer prefetcher will prefetch data streams from the cache memory to the DCU (Data Cache Unit) to speed up data accessing and processing for CPU performance enhancement. The options are Disable and **Enable**.

DCU IP Prefetcher

If this feature is set to Enable, the IP prefetcher in the DCU (Data Cache Unit) will prefetch IP addresses to improve network connectivity and system performance. The options are **Enable** and Disable.

LLC Prefetch

If this feature is set to Enable, LLC (hardware cache) prefetching on all threads will be supported. The options are **Disable** and Enable.

Extended APIC (Extended Advanced Programmable Interrupt Controller)

Based on the Intel Hyper-Threading technology, each logical processor (thread) is assigned 256 APIC IDs (APIDs) in 8-bit bandwidth. When this feature is set to Enable, the APIC ID will be expanded from 8 bits to 16 bits to provide 512 APIDs to each thread to enhance CPU performance. The options are **Disable** and Enable.

AES-NI

Select Enable to use the Intel Advanced Encryption Standard (AES) New Instructions (NI) to ensure data security. The options are **Enable** and Disable.

► Advanced Power Management Configuration

► CPU P State Control

SpeedStep (PStates)

EIST (Enhanced Intel SpeedStep Technology) allows the system to automatically adjust processor voltage and core frequency in an effort to reduce power consumption and heat dissipation. Please refer to Intel's website for detailed information. The options are Disable and **Enable**.

EIST PSD Function (Available when SpeedStep is set to Enable)

Use this feature to configure the processor's P-State coordination settings. During a P-State, the voltage and frequency of the processor will be reduced when it is in operation. This makes the processor more energy efficient, resulting in further energy gains. The options are **HW_ALL**, **SW_ALL** and **SW-ANY**.

Turbo Mode (Available when SpeedStep is set to Enable)

Select Enable for processor cores to run faster than the frequency specified by the manufacturer. The options are Disable and **Enable**.

► Hardware PM (Power Management) State Control

Hardware P-States

If this feature is set to Disable, hardware will choose a P-state setting for the system based on an OS request. If this feature is set to Native Mode, hardware will choose a P-state setting based on OS guidance. If this feature is set to Native Mode with No Legacy Support, hardware will choose a P-state setting independently without OS guidance. The options are **Disable**, Native Mode, Out of Band Mode, and Native Mode with No Legacy Support.

► CPU C State Control

Autonomous Core C-State

Select Enable to support Autonomous Core C-State control which will allow the processor core to control its C-State setting automatically and independently. The options are Enable and **Disable**.

CPU C6 Report

Select Enable to allow the BIOS to report the CPU C6 state (ACPI C3) to the operating system. During the CPU C6 state, power to all caches is turned off. The options are **Auto**, Enable, and Disable.

Enhanced Halt State (C1E)

Select Enable to enable "Enhanced Halt State" support, which will significantly reduce the CPU's power consumption by minimizing CPU's clock cycles and reduce voltage during a "Halt State." The options are Disable and **Enable**.

► Package C State Control

Package C State

Use this feature to set the limit on the C-State package register. The options are C0/1 state, C2 state, C6 (non-Retention) state, C6 (Retention) state, No Limit, and **Auto**.

► CPU T State Control

Software Controlled T-States

If this feature is set to Enable, CPU throttling settings will be supported by the software of the system. The options are **Disable** and Enable.

► Chipset Configuration

Warning: Setting the wrong values in the following sections may cause the system to malfunction.

► North Bridge

This feature allows the user to configure the settings for the Intel North Bridge.

► UPI (Ultra Path Interconnect) Configuration

This section displays the following UPI General Configuration information:

- Number of CPU
- Number of IIO
- Current UPI Link Speed
- Current UPI Link Frequency
- UPI Global MMIO Low Base/Limit
- UPI Global MMIO High Base/Limit
- UPI PCI-E Configuration Base/Size

Degrade Precedence

Use this feature to select the degrading precedence option for Ultra Path Interconnect connections. Select Topology Precedent to degrade UPI features if system options are in conflict. Select Feature Precedent to degrade UPI topology if system options are in conflict. The options are **Topology Precedence** and Feature Precedence.

Link L0p Enable

Select Enable to enable Link L0p. The options are Disable, Enable, and **Auto**.

Link L1 Enable

Select Enable to enable Link L1 (Level 1 link). The options are Disable, Enable, and **Auto**.

IO Directory Cache

Select Enable for the IODC (I/O Directory Cache) to generate snoops instead of generating memory lockups for remote IIO (InvlToM) and/or WCiLF (Cores). Select Auto for the IODC to generate snoops (instead of memory lockups) for WCiLF (Cores). The options are Disable, **Auto**, Enable for Remote InvltoM Hybrid Push, InvltoM AllocFlow, Enable for Remote InvltoM Hybrid AllocNonAlloc, and Enable for Remote InvltoM and Remote WViLF.

Isoc Mode

Select Enable to enable Isochronous support to meet QoS (Quality of Service) requirements. This feature is especially important for Virtualization Technology. The options are Disable, Enable, and **Auto**.

►Memory Configuration**Enforce POR**

Select POR to enforce POR restrictions for DDR4 memory frequency and voltage programming. The options are **POR** and Disable.

Memory Frequency

Use this feature to set the maximum memory frequency for onboard memory modules. The options are **Auto**, 1866, 2000, 2133, 2200, 2400, 2600, 2666, and 2933.

Data Scrambling for NVDIMM

Select Enable to enable data scrambling for onboard NVDIMM memory to enhance system performance and security. The options are **Auto**, Disable, and Enable.

Data Scrambling for DDR4

Select Enable to enable data scrambling for DDR4 memory to enhance system performance and security. The options are **Auto**, Disable, and Enable.

tCCD_L Relaxation

If this feature is set to Enable, SPD (Serial Presence Detect) will override tCCD_L ("Column to Column Delay-Long", or "Command to Command Delay-Long" on the column side.) If this feature is set to Disable, tCCD_L will be enforced based on the memory frequency. The options are Enable and **Disable**.

Enable ADR

Select Enable for ADR (Automatic Diagnostic Repository) support to enhance memory performance. The options are Enable and **Disable**.

2X Refresh

Select Enable for memory 2X refresh support to enhance memory performance. The options are Enable and **Auto**.

►Memory Topology

This item displays the information of onboard memory modules as detected by the BIOS.

- P1 DIMMA1/P1 DIMMA2 to P1 DIMMF1/P1 DIMMF2
- P2 DIMMA1/P2 DIMMA2 to P2 DIMMF1/P2 DIMMF2

►Memory RAS (Reliability_Availability_Serviceability) Configuration

Use this submenu to configure the following Memory RAS settings.

Static Virtual Lockstep Mode

Select Enable to support Static Virtual Lockstep mode to enhance memory performance. The options are Enable and **Disable**.

Mirror Mode

Use this feature to configure the mirror mode settings for all 1LM/2LM memory modules installed in the system which will create a duplicate copy of data stored in the memory to increase memory security, but it will reduce the memory capacity into half. The options are **Disable**, Mirror Mode 1LM, and Mirror Mode 2LM.

UEFI ARM Mirror

If this feature is set to Enable, mirror mode configuration settings for UEFI-based Address Range memory will be activated upon system boot. This will create a duplicate copy of data stored in the memory to increase memory security, but it will reduce the memory capacity into half. The options are **Disable** and Enable.

Memory Rank Sparing

Select Enable to support memory-rank sparing to optimize memory performance. The options are Enable and **Disable**.

Note: This item will not be available when memory mirror mode is enabled.

Correctable Error Threshold

Use this item to enter the threshold value for correctable memory errors. The default setting is 10.

SDDC Plus One

Select Enable for SDDC (Single Device Data Correction) Plus One support, which will increase the reliability and serviceability of your system memory. The options are Enable and **Disable**.

ADDDC (Adaptive Double Device Data Correction) Sparing

Select Enable for ADDDC sparing support to enhance memory performance. The options are Enable and **Disable**.

Patrol Scrub

Patrol Scrubbing is a process that allows the CPU to correct correctable memory errors detected in a memory module and send the corrections to the requestor (the original source). When this item is set to Enable, the IO hub will read and write back one cache line every 16K cycles if there is no delay caused by internal processing. By using this method, roughly 64 GB of memory behind the IO hub will be scrubbed every day. The options are **Enable** and Disable.

Patrol Scrub Interval

Use this item to specify the number of hours (between 0 to 24) required for the system to complete a full patrol scrubbing. Enter 0 for patrol scrubbing to be performed automatically. The default setting is **24**.

Note: This item is hidden when Patrol Scrub item is set to Disable.

► IIO Configuration

EV DFX (Device Function On-Hide) Features

When this feature is set to Enable, the EV_DFX Lock Bits that are located in a processor will always remain clear during electric tuning. The options are **Disable** and **Enable**.

► CPU1 Configuration/CPU2 Configuration

IOU0 (IIO PCIe Br1)

This feature configures the PCI-E Bifurcation setting for a PCI-E port specified by the user. The options are x4x4x4x4, x4x4x8, x8x4x4, x8x8, x16, and **Auto**.

IOU1 (IIO PCIe Br2)

This feature configures the PCI-E Bifurcation setting for a PCI-E port specified by the user. The options are x4x4x4x4, x4x4x8, x8x4x4, x8x8, x16, and **Auto**.

IOU2 (IIO PCIe Br3)

This feature configures the PCI-E Bifurcation setting for a PCI-E port specified by the user. The options are x4x4x4x4, x4x4x8, x8x4x4, x8x8, x16, and **Auto**.

MCP0 (IIO PCIe Br4)

This feature configures the PCI-E Bifurcation setting for a PCI-E port specified by the user. The options are x16 and **Auto**.

MCP1 (IIO PCIe Br5)

This feature configures the PCI-E Bifurcation setting for a PCI-E port specified by the user. The options are x16 and **Auto**.

► CPU1 PCI-E Br0D00F0 - Port 0/DMI (Available for CPU 1 Configuration only)

Link Speed

This feature configures the link speed of a PCI-E port specified by the user. The options are **Auto**, Gen 1 (Generation 1) (2.5 GT/s), Gen 2 (Generation 2) (5 GT/s), and Gen 3 (Generation 3) (8 GT/s)

The following information will be displayed as well:

- PCI-E Port Link Status
- PCI-E Port Link Max
- PCI-E Port Link Speed

PCI-E Port Max (Maximum) Payload Size (Available for CPU 1 Configuration only)

Select Auto for the system BIOS to automatically set the maximum payload value for a PCI-E device specified by to user to enhance system performance. The options are **Auto**, 128B, and 256B.

► IOAT Configuration

Disable TPH (TLP Processing Hint)

TPH is used for data-tagging with a destination ID and a few important attributes. It can send critical data to a particular cache without writing through to memory. Select No in this item for TLP Processing Hint support, which will allow a "TLP request" to provide "hints" to help optimize the processing of each transaction occurred in the target memory space. The options are Yes and **No**.

Prioritize TPH (TLP Processing Hint)

Select Yes to prioritize the TLP requests that will allow the "hints" to be sent to help facilitate and optimize the processing of certain transactions in the system memory. The options are Enable and **Disable**.

Relaxed Ordering

Select Enable to enable Relaxed Ordering support which will allow certain transactions to violate the strict-ordering rules of PCI and to be completed prior to other transactions that have already been enqueued. The options are **Disable** and Enable.

► Intel® VT for Directed I/O (VT-d)

Intel® VT for Directed I/O (VT-d)

Select Enable to use Intel Virtualization Technology support for Direct I/O VT-d by reporting the I/O device assignments to the VMM (Virtual Machine Monitor) through the DMAR ACPI tables. This feature offers fully-protected I/O resource sharing across Intel platforms, providing greater reliability, security and availability in networking and data-sharing. The options are **Enable** and Disable.

Interrupt Remapping

Select Enable for Interrupt Remapping support to enhance system performance. The options are **Enable** and Disable.

PassThrough DMA

Select Enable for the Non-IscoH VT-d engine to pass through DMA (Direct Memory Access) to enhance system performance. The options are **Enable** and Disable.

ATS

Select Enable to enable ATS (Address Translation Services) support for the Non-IscoH VT-d engine to enhance system performance. The options are **Enable** and Disable.

Posted Interrupt

Select Enable to support VT_D Posted Interrupt which will allow external interrupts to be sent directly from a direct-assigned device to a client machine in non-root mode to improve virtualization efficiency by simplifying interrupt migration and lessening the need of physical interrupts. The options are **Enable** and Disable.

Coherency Support (Non-Iscoch)

Select Enable for the Non-Iscoch VT-d engine to pass through DMA (Direct Memory Access) to enhance system performance. The options are **Enable** and Disable.

► Intel® VT for Directed I/O (VT-d)

IIO-PCIE Express Global Options

The section allows the user to configure the following PCI-E global options:

PCI-E Completion Timeout Disable

Select Yes to disable the PCI-E Completion Time-out settings. The options are **Yes**, No, and Per-Port.

► South Bridge

The following South Bridge information will display:

- USB Module Version
- USB Devices

Legacy USB Support

Select Enabled to support onboard legacy USB devices. Select Auto to disable legacy support if there are no legacy USB devices present. Select Disable to have all USB devices available for EFI applications only. The options are **Enabled**, Disabled and Auto.

XHCI Hand-Off

This is a work-around solution for operating systems that do not support XHCI (Extensible Host Controller Interface) hand-off. The XHCI ownership change should be claimed by the XHCI driver. The options are Enabled and **Disabled**.

Port 60/64 Emulation

Select Enabled for I/O port 60h/64h emulation support, which in turn, will provide complete legacy USB keyboard support for the operating systems that do not support legacy USB devices. The options are **Enabled** and Disabled.

► **Server ME (Management Engine) Configuration**

This feature displays the following system ME configuration settings.

General ME Configuration

Operational Firmware Version

Backup Firmware Version

Recovery Firmware Version

ME Firmware Status #1/ME Firmware Status #2

 Current State

 Error Code

► **PCH SATA Configuration**

When this submenu is selected, the AMI BIOS automatically detects the presence of the SATA devices that are supported by the Intel PCH chip and displays the following items:

SATA Controller

This item enables or disables the onboard SATA controller supported by the Intel PCH chip. The options are **Enable** and Disable.

Configure SATA as (Available when the item above: SATA Controller is set to enabled)

Select AHCI to configure a SATA drive specified by the user as an AHCI drive. Select RAID to configure a SATA drive specified by the user as a RAID drive. The options are **AHCI** and RAID. (**Note:** This item is hidden when the SATA Controller item is set to Disabled.)

SATA HDD Unlock

Select Enable to unlock SATA HDD password in the OS. The options are **Enable** and Disable.

SATA/sSATA RAID Boot Select (Available when the item "Configure SATA as" is set to "RAID")

This feature allows the user to decide which controller should be used for system boot. The options are None, SATA Controller, **sSATA Controller**, and Both.

Aggressive Link Power Management

When this item is set to Enabled, the SATA AHCI controller manages the power use of the SATA link. The controller will put the link in a low power mode during an extended period of I/O inactivity, and will return the link to an active state when I/O activity resumes. The options are Enable and **Disable**.

SATA RAID Option ROM/UEFI Driver (Available when the item "Configure SATA as" is set to "RAID")

Select EFI to load the EFI driver for system boot. Select Legacy to load a legacy driver for system boot. The options are Disable, EFI, and **Legacy**.

SATA Port 0 - SATA Port 7**Hot Plug**

Select Enable to support Hot-plugging for the device installed on a selected SATA port which will allow the user to replace the device installed in the slot without shutting down the system. The options are Enable and **Disable**.

Spin Up Device

On an edge detect from 0 to 1, set this item to allow the SATA device installed on the SATA port specified by the user to start a COMRESET initialization. The options are Enable and **Disable**.

SATA Device Type

Use this item to specify if the device installed on the SATA port selected by the user should be connected to a Solid State drive or a Hard Disk Drive. The options are **Hard Disk Drive** and Solid State Drive.

►PCH sSATA Configuration

When this submenu is selected, AMI BIOS automatically detects the presence of the sSATA devices that are supported by the PCH sSATA controller and displays the following items:

sSATA Controller

This item enables or disables the onboard sSATA controller supported by the Intel SCU. The options are **Enable** and Disable.

Configure sSATA as

Select AHCI to configure an sSATA drive specified by the user as an AHCI drive. Select RAID to configure an sSATA drive specified by the user as a RAID drive. The options are **AHCI** and RAID. (**Note:** This item is hidden when the sSATA Controller item is set to Disabled.)

SATA HDD Unlock

Select Enable to unlock sSATA HDD password in the OS. The options are **Enable** and Disable.

SATA/sSATA RAID Boot Select (Available when the item "Configure SATA as" is set to "RAID")

This feature allows the user to decide which controller should be used for system boot. The options are None, SATA Controller, **sSATA Controller**, and Both.

Support Aggressive Link Power Management

When this item is set to Enable, the sSATA AHCI controller manages the power use of the SATA link. The controller will put the link in a low power mode during an extended period of I/O inactivity, and will return the link to an active state when I/O activity resumes. The options are **Disable** and Enable.

sSATA RAID Option ROM/UEFI Driver (Available when the item "Configure SATA as" is set to "RAID")

Select EFI to load the EFI driver for system boot. Select Legacy to load a legacy driver for system boot. The options are Disable, EFI, and **Legacy**.

sSATA Port 0 - sSATA Port 5

Hot Plug

Select Enable to support Hot-plugging for the device installed on an sSATA port selected by the user which will allow the user to replace the device installed in the slot without shutting down the system. The options are **Disable** and Enabled.

Spin Up Device

On an edge detect from 0 to 1, set this item to allow the sSATA device installed on the sSATA port specified by the user to start a COMRESET initialization. The options are Enable and **Disable**.

sSATA Device Type

Use this item to specify if the device installed on the sSATA port specified by the user should be connected to a Solid State drive or a Hard Disk Drive. The options are **Hard Disk Drive** and Solid State Drive.

►PCIe/PCI/PnP Configuration

The following PCI information will be displayed:

- PCI Bus Driver Version
- PCI Devices Common Settings:

Above 4G Decoding (Available if the system supports 64-bit PCI decoding)

Select Enabled to decode a PCI device that supports 64-bit in the space above 4G Address. The options are **Enabled** and Disabled.

SR-IOV Support (Available if the system supports Single-Root Virtualization)

Select Enabled for Single-Root IO Virtualization support. The options are Enabled and **Disabled**.

MMIO High Base

Use this feature to select the base memory size according to memory-address mapping for the IO hub. The base memory size must be between 4032G to 4078G. The options are **56T**, 40T, 24T, 16T, 4T, and 1T.

MMIO High Granularity Size

Use this feature to select the high memory size according to memory-address mapping for the IO hub. The options are 1G, 4G, 16G, 64G, **256G**, and 1024G.

PCI PERR/SERR Support

Use this feature to enable or disable the runtime event for SERR (System Error)/ PERR (PCI/ PCI-E Parity Error). The options are Disabled and **Enabled**.

Maximum Read Request

Select Auto for the system BIOS to automatically set the maximum size for a read request for a PCI-E device to enhance system performance. The options are **Auto**, 128 Bytes, 256 Bytes, 512 Bytes, 1024 Bytes, 2048 Bytes, and 4096 Bytes.

MMCFG Base

This feature determines the lowest MMCFG (Memory-Mapped Configuration) base assigned to PCI devices. The options are 1G, 1.5G, 1.75G, **2G**, 2.25G, and 3G.

NVMe Firmware Source

This feature determines which type of the NVMe firmware should be used in your system. The options are **Vendor Defined Firmware** and AMI Native Support.

VGA Priority

This feature selects the graphics device to be used as the primary video display for system boot. The options are Auto, **Onboard** and Offboard.

SIOM: CPU1 PCI-E 3.0X16 Option ROM

Use this feature to select the Onboard SIOM Option ROM type for system boot. The options are Disabled, **Legacy** and EFI.

Onboard SAS Option ROM

Use this feature to select the Onboard SAS Option ROM type for system boot. The options are Disabled, **Legacy** and EFI.

Onboard Video Option ROM

Use this feature to select the Onboard Video Option ROM type. The options are Disabled, **Legacy** and EFI.

► Network Stack Configuration

Network Stack

Select Enabled to enable PXE (Preboot Execution Environment) or UEFI (Unified Extensible Firmware Interface) for network stack support. The options are **Enabled** and Disabled.

**If "Network Stack" is set to Enabled, the following items will display:*

Ipv4 PXE Support

Select Enabled to enable Ipv4 PXE boot support. If this feature is disabled, it will not create the Ipv4 PXE boot option. The options are Disabled and **Enabled**.

Ipv4 HTTP Support

Select Enabled to enable Ipv4 HTTP boot support. If this feature is disabled, it will not create the Ipv4 HTTP boot option. The options are Enabled and **Disabled**.

Ipv6 PXE Support

Select Enabled to enable Ipv6 PXE boot support. If this feature is disabled, it will not create the Ipv6 PXE boot option. The options are Disabled and **Enabled**.

Ipv6 HTTP Support

Select Enabled to enable Ipv6 HTTP boot support. If this feature is disabled, it will not create the Ipv6 HTTP boot option. The options are Enabled and **Disabled**.

PXE Boot Wait Time

Use this feature to select the wait time to press the <ESC> key to abort the PXE boot. The default is **0**.

Media Detect Time

Use this feature to select the wait time in seconds for the BIOS ROM to detect the LAN media (Internet connection or LAN port). The default is **1**.

► Super IO Configuration

Super IO Chip AST2500

► Serial Port 1 Configuration

Serial Port

Select Enabled to enable the onboard serial port specified by the user. The options are **Enabled** and Disabled.

Device Settings

This feature displays the base I/O port address and the Interrupt Request address of a serial port specified by the user.

Note: This item is hidden when Serial Port 1 is set to Disabled.

Change Settings

This feature specifies the base I/O port address and the Interrupt Request address of Serial Port 1. Select **Auto** for the BIOS to automatically assign the base I/O and IRQ address to a serial port specified.

The options for Serial Port 1 are **Auto**, (IO=3F8h; IRQ=4), (IO=3F8h; IRQ=3, 4, 5, 6, 7, 9, 10, 11, 12), (IO=2F8h; IRQ=3, 4, 5, 6, 7, 9, 10, 11, 12); (IO=3E8h; IRQ=3, 4, 5, 6, 7, 9, 10, 11, 12), and (IO=2E8h; IRQ=3, 4, 5, 6, 7, 9, 10, 11, 12).

► Serial Port 2 Configuration

Serial Port

Select Enabled to enable the onboard serial port specified by the user. The options are **Enabled** and Disabled.

Device Settings

This feature displays the base I/O port address and the Interrupt Request address of a serial port specified by the user.

Note: This item is hidden when Serial Port 1 is set to Disabled.

Change Settings

This feature specifies the base I/O port address and the Interrupt Request address of Serial Port 2. Select Auto for the BIOS to automatically assign the base I/O and IRQ address to a serial port specified. The options for Serial Port 2 are **Auto**, (IO=2F8h; IRQ=3), (IO=3F8h; IRQ=3, 4, 5, 6, 7, 9, 10, 11, 12), (IO=2F8h; IRQ=3, 4, 5, 6, 7, 9, 10, 11, 12); (IO=3E8h; IRQ=3, 4, 5, 6, 7, 9, 10, 11, 12), and (IO=2E8h; IRQ=3, 4, 5, 6, 7, 9, 10, 11, 12).

Serial Port 2 Attribute

Select SOL to use COM Port 2 as a Serial_Over_LAN (SOL) port for console redirection. The options are COM and **SOL**.

►Serial Port Console Redirection

COM 1 Console Redirection

Select Enabled to enable COM Port 1 for Console Redirection, which will allow a client machine to be connected to a host machine at a remote site for networking. The options are Enabled and **Disabled**.

**If the item above set to Enabled, the following items will become available for configuration:*

►Console Redirection Settings (for COM1)

Terminal Type

Use this feature to select the target terminal emulation type for Console Redirection. Select VT100 to use the ASCII Character set. Select VT100+ to add color and function key support. Select ANSI to use the Extended ASCII Character Set. Select VT-UTF8 to use UTF8 encoding to map Unicode characters into one or more bytes. The options are ANSI, VT100, **VT100+**, and VT-UTF8.

Bits Per second

Use this feature to set the transmission speed for a serial port used in Console Redirection. Make sure that the same speed is used in the host computer and the client computer. A lower transmission speed may be required for long and busy lines. The options are 9600, 19200, 38400, 57600 and **115200** (bits per second).

Data Bits

Use this feature to set the data transmission size for Console Redirection. The options are 7 (Bits) and **8 (Bits)**.

Parity

A parity bit can be sent along with regular data bits to detect data transmission errors. Select Even if the parity bit is set to 0, and the number of 1's in data bits is even. Select Odd if the parity bit is set to 0, and the number of 1's in data bits is odd. Select None if you do not want to send a parity bit with your data bits in transmission. Select Mark to add a mark as a parity bit to be sent along with the data bits. Select Space to add a Space as a parity bit to be sent with your data bits. The options are **None**, Even, Odd, Mark and Space.

Stop Bits

A stop bit indicates the end of a serial data packet. Select 1 Stop Bit for standard serial data communication. Select 2 Stop Bits if slower devices are used. The options are **1** and **2**.

Flow Control

Use this feature to set the flow control for Console Redirection to prevent data loss caused by buffer overflow. Send a "Stop" signal to stop sending data when the receiving buffer is full. Send a "Start" signal to start sending data when the receiving buffer is empty. The options are **None** and Hardware RTS/CTS.

VT-UTF8 Combo Key Support

Select Enabled to enable VT-UTF8 Combination Key support for ANSI/VT100 terminals. The options are **Enabled** and Disabled.

Recorder Mode

Select Enabled to capture the data displayed on a terminal and send it as text messages to a remote server. The options are **Disabled** and Enabled.

Resolution 100x31

Select Enabled for extended-terminal resolution support. The options are Disabled and **Enabled**.

Legacy OS Redirection Resolution

Use this feature to select the number of rows and columns used in Console Redirection for legacy OS support. The options are **80x24** and 80x25.

Putty KeyPad

This feature selects Function Keys and KeyPad settings for Putty, which is a terminal emulator designed for the Windows OS. The options are **VT100**, LINUX, XTERMR6, SCO, ESCN, and VT400.

Redirection After BIOS Post

Use this feature to enable or disable legacy Console Redirection after BIOS POST. When the option-Bootloader is selected, legacy Console Redirection is disabled before booting the OS. When the option-Always Enable is selected, legacy Console Redirection remains enabled upon OS bootup. The options are **Always Enable** and Bootloader.

SOL (Serial-Over-LAN)/COM2**Console Redirection (for SOL/COM2)**

Select Enabled to use the SOL port for Console Redirection. The options are **Enabled** and Disabled.

**If the item above set to Enabled, the following items will become available for user's configuration:*

► Console Redirection Settings (for SOL/COM2)

Use this feature to specify how the host computer will exchange data with the client computer, which is the remote computer used by the user.

Terminal Type

Use this feature to select the target terminal emulation type for Console Redirection. Select VT100 to use the ASCII Character set. Select VT100+ to add color and function key support. Select ANSI to use the Extended ASCII Character Set. Select VT-UTF8 to use UTF8 encoding to map Unicode characters into one or more bytes. The options are ANSI, VT100, **VT100+**, and VT-UTF8.

Bits Per second

Use this feature to set the transmission speed for a serial port used in Console Redirection. Make sure that the same speed is used in the host computer and the client computer. A lower transmission speed may be required for long and busy lines. The options are 9600, 19200, 38400, 57600 and **115200** (bits per second).

Data Bits

Use this feature to set the data transmission size for Console Redirection. The options are 7 (Bits) and **8 (Bits)**.

Parity

A parity bit can be sent along with regular data bits to detect data transmission errors. Select Even if the parity bit is set to 0, and the number of 1's in data bits is even. Select Odd if the parity bit is set to 0, and the number of 1's in data bits is odd. Select None if you do not want to send a parity bit with your data bits in transmission. Select Mark to add a mark as a parity bit to be sent along with the data bits. Select Space to add a Space as a parity bit to be sent with your data bits. The options are **None**, Even, Odd, Mark and Space.

Stop Bits

A stop bit indicates the end of a serial data packet. Select 1 Stop Bit for standard serial data communication. Select 2 Stop Bits if slower devices are used. The options are **1** and 2.

Flow Control

Use this feature to set the flow control for Console Redirection to prevent data loss caused by buffer overflow. Send a "Stop" signal to stop sending data when the receiving buffer is full. Send a "Start" signal to start data-sending when the receiving buffer is empty. The options are **None** and Hardware RTS/CTS.

VT-UTF8 Combo Key Support

Select Enabled to enable VT-UTF8 Combination Key support for ANSI/VT100 terminals. The options are **Enabled** and Disabled.

Recorder Mode

Select Enabled to capture the data displayed on a terminal and send it as text messages to a remote server. The options are **Disabled** and Enabled.

Resolution 100x31

Select Enabled for extended-terminal resolution support. The options are Disabled and **Enabled**.

Legacy OS Redirection Resolution

Use this feature to select the number of rows and columns used in Console Redirection for legacy OS support. The options are **80x24** and 80x25.

Putty KeyPad

This feature selects Function Keys and KeyPad settings for Putty, which is a terminal emulator designed for the Windows OS. The options are **VT100**, LINUX, XTERMR6, SCO, ESCN, and VT400.

Redirection After BIOS Post

Use this feature to enable or disable legacy Console Redirection after BIOS POST (Power-On Self-Test). When this feature is set to Bootloader, legacy Console Redirection is disabled before booting the OS. When this feature is set to Always Enable, legacy Console Redirection remains enabled upon OS boot. The options are **Always Enable** and Bootloader.

► Legacy Console Redirection Settings**Legacy Console Redirection Settings**

Use the feature to select the COM port to display redirection of Legacy OS and Legacy OPROM messages. The default setting is **COM1**.

Serial Port for Out-of-Band Management/Windows Emergency Management Services (EMS)

The submenu allows the user to configure Console Redirection settings to support Out-of-Band Serial Port management.

Console Redirection (for EMS)

Select Enabled to use a COM port selected by the user for EMS Console Redirection. The options are **Disabled** and Enabled.

**If the item above set to Enabled, the following items will become available for user's configuration:*

►EMS Console Redirection Settings

Out-of-Band Management Port

The feature selects a serial port in a client server to be used by the Windows Emergency Management Services (EMS) to communicate with a remote host server. The options are **COM1 (Console Redirection)** and COM2/SOL (Console Redirection).

Terminal Type

Use this feature to select the target terminal emulation type for Console Redirection. Select VT100 to use the ASCII character set. Select VT100+ to add color and function key support. Select ANSI to use the extended ASCII character set. Select VT-UTF8 to use UTF8 encoding to map Unicode characters into one or more bytes. The options are ANSI, VT100, VT100+, and **VT-UTF8**.

Bits Per Second

This feature sets the transmission speed for a serial port used in Console Redirection. Make sure that the same speed is used in both host computer and the client computer. A lower transmission speed may be required for long and busy lines. The options are 9600, 19200, 57600, and **115200** (bits per second).

Flow Control

Use this feature to set the flow control for Console Redirection to prevent data loss caused by buffer overflow. Send a "Stop" signal to stop data-sending when the receiving buffer is full. Send a "Start" signal to start data-sending when the receiving buffer is empty. The options are **None**, Hardware RTS/CTS, and Software Xon/Xoff.

The setting for each these features is displayed:

Data Bits, Parity, Stop Bits

►ACPI Settings

Use this feature to configure Advanced Configuration and Power Interface (ACPI) power management settings for your system.

NUMA Support (Available when the OS supports this feature)

Select Enabled to enable Non-Uniform Memory Access support to enhance system performance. The options are **Enabled** and Disabled.

WHEA Support

Select Enabled to support the Windows Hardware Error Architecture (WHEA) platform and provide a common infrastructure for the system to handle hardware errors within the Windows OS environment to reduce system crashes and to enhance system recovery and health monitoring. The options are **Enabled** and Disabled.

High Precision Timer

Select Enabled to activate the High Precision Event Timer (HPET) that produces periodic interrupts at a much higher frequency than a Real-time Clock (RTC) does in synchronizing multimedia streams, providing smooth playback and reducing the dependency on other timestamp calculation devices, such as an x86 RDTSC Instruction embedded in the CPU. The High Performance Event Timer is used to replace the 8254 Programmable Interval Timer. The options are **Enabled** and Disabled.

► Trusted Computing (Available when a TPM device is installed and detected by the BIOS)

When a TPM (Trusted-Platform Module) device is detected in your machine, the following information will be displayed.

- TPM2.0 Device Found
- Vendor
- Firmware Version

Security Device Support

If this feature and the TPM jumper (JPT1) on the motherboard are both enabled, the onboard security (TPM) device will be enabled in the BIOS to enhance data integrity and system security. Please note that the OS will not show the security device. Neither TCG EFI protocol nor INT1A interaction will be made available for use. If you have made changes on the setting on this item, be sure to reboot the system for the change to take effect. The options are Disable and **Enable**. If this option is set to Enable, the following screen and items will display:

- Active PCR Banks
- Available PCR Banks

Pending Operation

Use this feature to schedule a TPM-related operation to be performed by a security (TPM) device at the next system boot to enhance system data integrity. Your system will reboot to carry out a pending TPM operation. The options are **None** and TPM Clear.

Note: Your system will reboot to carry out a pending TPM operation.

Platform Hierarchy (for TPM Version 2.0 and above)

Select Enabled for TPM Platform Hierarchy support which will allow the manufacturer to utilize the cryptographic algorithm to define a constant key or a fixed set of keys to be used for initial system boot. This early boot code is shipped with the platform and is included in the list of "public keys". During system boot, the platform firmware uses this trusted public key to verify a digital signature in an attempt to manage and control the security of the platform firmware used in a host system via a TPM device. The options are **Enabled** and Disabled.

Storage Hierarchy

Select Enabled for TPM Storage Hierarchy support that is intended to be used for non-privacy-sensitive operations by the platform owner such as an IT professional or the end user. Storage Hierarchy has an owner policy and an authorization value, both of which can be set and are held constant (-rarely changed) through reboots. This hierarchy can be cleared or changed independently of the other hierarchies. The options are **Enabled** and Disabled.

Endorsement Hierarchy

Select Enabled for Endorsement Hierarchy support, which contains separate controls to address the user's privacy concerns because the primary keys in this hierarchy are certified by the TPM or a manufacturer to be constrained to an authentic TPM device that is attached to an authentic platform. A primary key can be an encrypted, and a certificate can be created using TPM2_ActivateCredential. It allows the user to independently enable "flag, policy, and authorization value" without involving other hierarchies. A user with privacy concerns can disable the endorsement hierarchy while still using the storage hierarchy for TPM applications and permitting the platform software to use the TPM. The options are **Enabled** and Disabled.

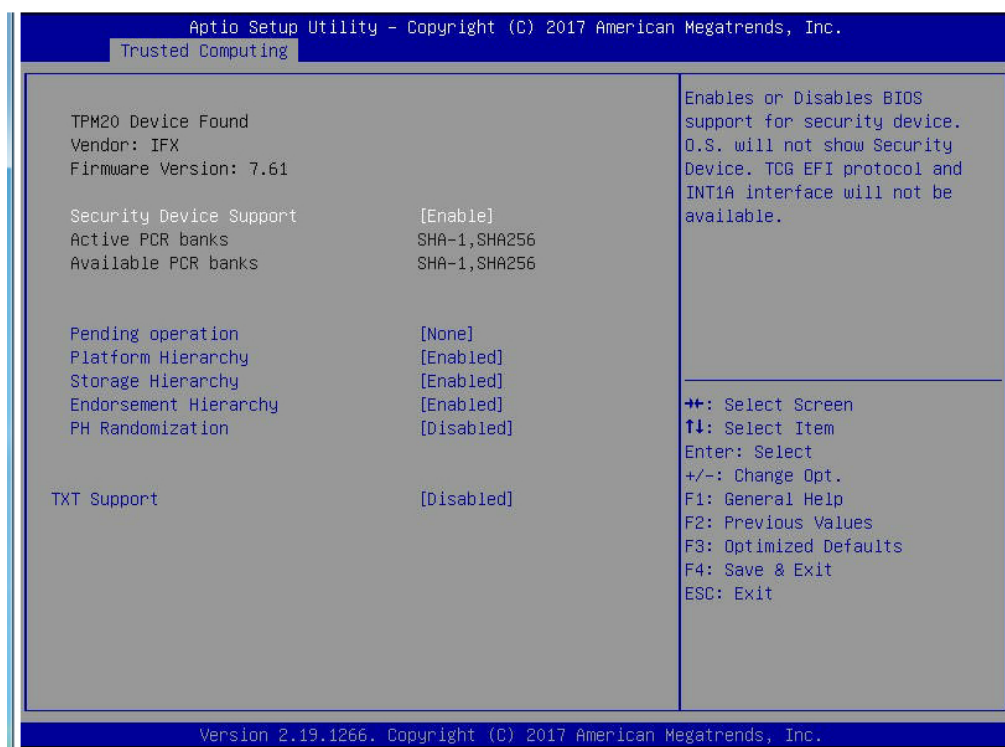

PH (Platform Hierarchy) Randomization (for TPM Version 2.0 and above)

Select Enabled for Platform Hierarchy Randomization support, which is used only during the platform developmental stage. This feature cannot be enabled in the production platforms. The options are **Disabled** and Enabled.

TXT Support

Select Enabled to enable Intel Trusted Execution Technology (TXT) support to enhance system security and data integrity. The options are **Disabled** and Enabled.

Note 1: If the option for this item (TXT Support) is set to Enabled, be sure to disable EV DFX (Device Function On-Hide) support for the system to work properly. (EV DFX is under "I/O Configuration" in the "Chipset/North Bridge" submenu).

Note 2: For more information on TPM, please refer to the TPM manual at <http://www.supermicro.com/manuals/other>.

► iSCSI Configuration**iSCSI Initiator Name**

This feature allows the user to enter the unique name of the iSCSI Initiator in IQN format. Once the name of the iSCSI Initiator is entered into the system, configure the proper settings for the following items.

► Add an Attempt**► Delete Attempts****► Change Attempt order****► Intel® Virtual RAID on CPU**

When this submenu is selected and the RAID devices are detected, the BIOS screen displays the following items:

Intel® VROC with VMD Technology 5.1.0.1006

6.4 Event Logs

Use this feature to configure Event Log settings.

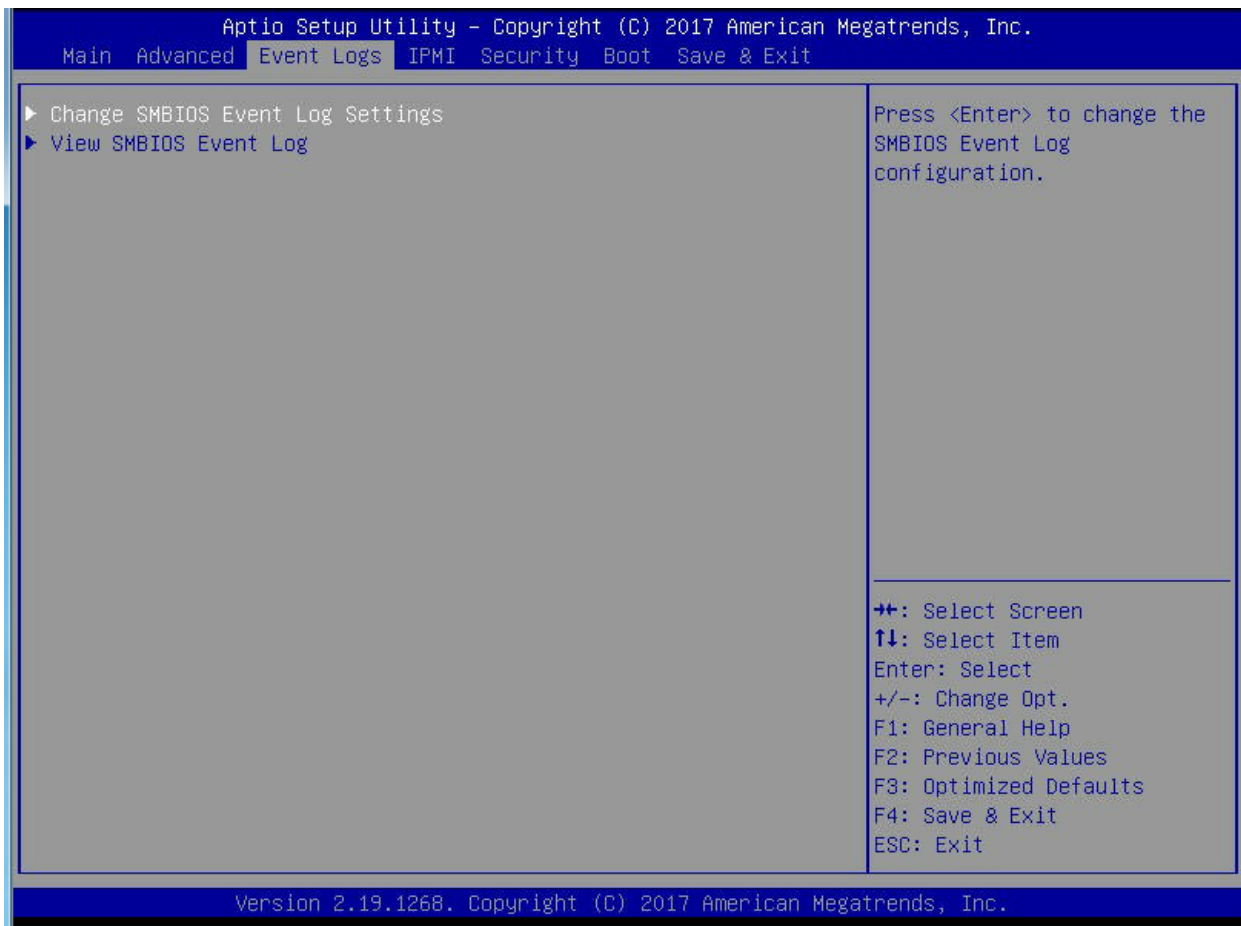

▶ Change SMBIOS Event Log Settings

Enabling/Disabling Options

SMBIOS Event Log

Select Enabled to enable SMBIOS (System Management BIOS) Event Logging during system boot. The options are **Enabled** and Disabled.

Erasing Settings

Erase Event Log

Select Enabled to erase all error events in the SMBIOS (System Management BIOS) log before an event logging is initialized at bootup. The options are **No**, Yes, Next Reset, and Yes, Next Reset.

When Log is Full

Select Erase Immediately to immediately erase all errors in the SMBIOS event log when the event log is full. Select Do Nothing for the system to do nothing when the SMBIOS event log is full. The options are **Do Nothing** and Erase Immediately.

SMBIOS Event Log Standard Settings

Log System Boot Event

Select Enabled to log system boot events. The options are Enabled and **Disabled**.

MECI (Multiple Event Count Increment)

Enter the increment value for the multiple event counter. Enter a number between 1 to 255. The default setting is 1.

METW (Multiple Event Count Time Window)

Use this feature to determine how long (in minutes) the multiple event counter should wait before generating a new event log. Enter a number between 0 to 99. The default setting is **60**.

Note: Please reboot the system for the changes to take effect.

Customer Options

Log OEM Codes

Select Enabled to log the EFI Status codes as OEM codes if these codes have not been converted to Legacy. The options are **Enabled** and Disabled.

Convert OEM Codes

Select Enabled to convert the EFI Status codes to standard SMBIOS codes. Please note that this option is not available for all EFI Status codes. The options are Enabled and **Disabled**.

Note: Please reboot the system for the changes to take effect.

►View System Event Log

This item allows the user to view the event in the system event log. Select this feature and press <Enter> to view the status of an event in the log. The following categories are displayed:

Date/Time/Error Code/Severity

6.5 IPMI

Use this feature to configure Intelligent Platform Management Interface (IPMI) settings.

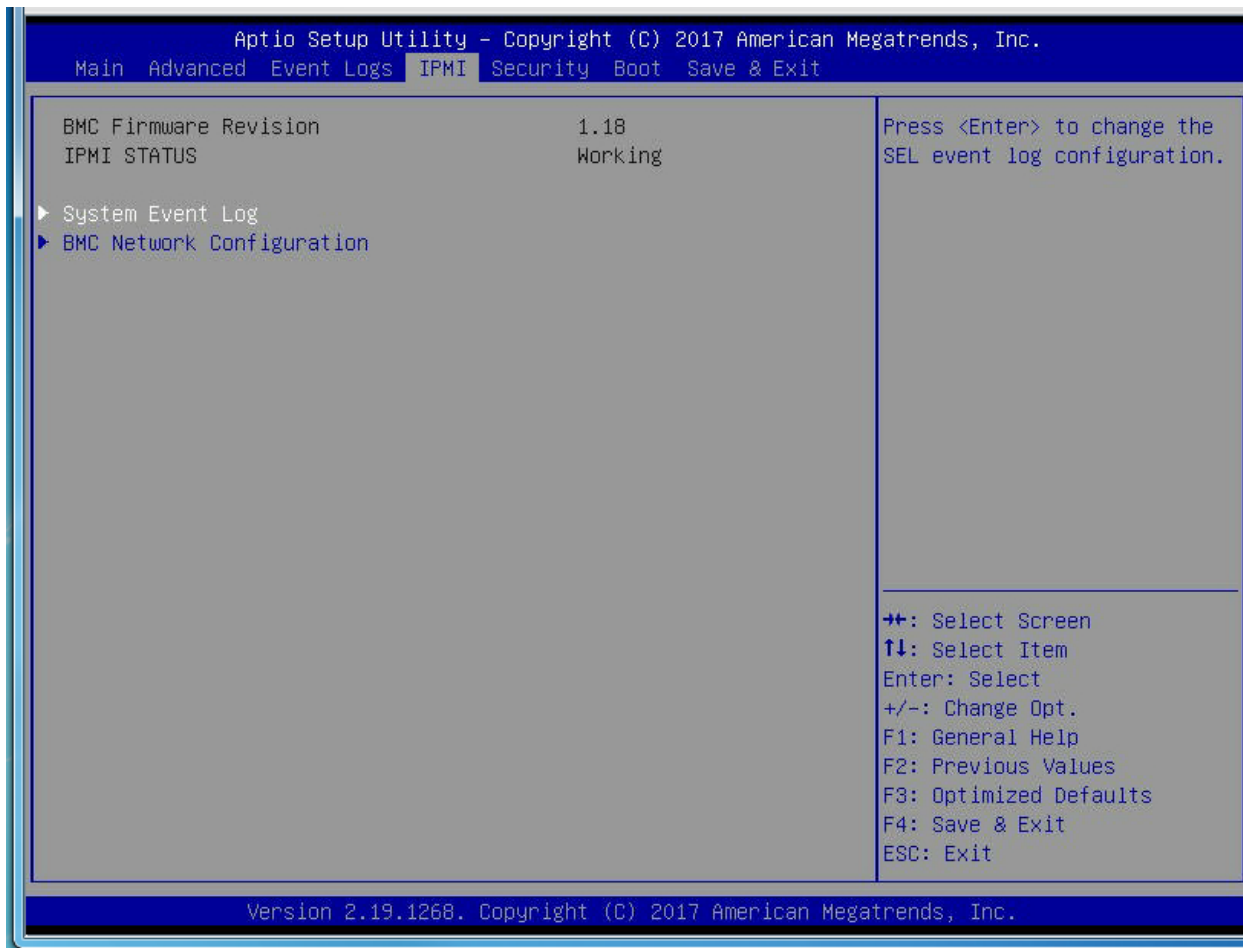

When you select this submenu and press the <Enter> key, the following information will display:

- **BMC Firmware Revision:** This feature indicates the IPMI firmware revision used in your system.
- **Status of BMC:** This feature indicates the status of the BMC (Baseboard Management Controller) installed in your system.

▶ System Event Log

Enabling/Disabling Options

SEL Components

Select Enabled for all system event logging at bootup. The options are **Enabled** and Disabled.

Erasing Settings

Erase SEL

Select Yes, On next reset to erase all system event logs upon next system reboot. Select Yes, On every reset to erase all system event logs upon each system reboot. Select No to keep all system event logs after each system reboot. The options are **No**, Yes, On next reset, and Yes, On every reset.

When SEL is Full

This feature allows the user to determine what the BIOS should do when the system event log is full. Select Erase Immediately to erase all events in the log when the system event log is full. The options are **Do Nothing** and Erase Immediately.

Custom EFI Logging Options

Log EFI Status Codes

Select EFI (Extensible Firmware Interface) Status Codes to log EFI status codes. Select Error Codes to log EFI error codes. Select Progress Code to log the EFI progress code. Select both to log both EFI error codes and progress codes. The options are Disabled, Both, **Error code** and Progress code.

Note: After making changes on a setting, be sure to reboot the system for the changes to take effect.

► BMC Network Configuration

The following items will be displayed:

- IPMI LAN Selection: This feature displays the IPMI LAN setting. The default setting is **Failover**.
- IPMI Network Link Status: This item displays the IPMI Network Link status. The default setting is **Dedicated LAN**.
- Update IPMI LAN Configuration: Select Yes for the BIOS to implement all IP/MAC address changes at the next system boot. The default setting is **No**.
- Current Configuration Address Source: This feature displays the source of the current IPMI LAN address. The default setting is **DHCP (Dynamic Host Configuration Protocol)**.
- Station IP Address: This feature displays the Station IP address for this computer. This should be in decimal and in dotted quad form (i.e., 192.168.10.253).
- Subnet Mask: This feature displays the sub-network that this computer belongs to. The value of each three-digit number separated by dots should not exceed 255.
- Station MAC Address: This feature displays the Station MAC address for this computer. Mac addresses are 6 two-digit hexadecimal numbers.

- Gateway IP Address: This feature displays the Gateway IP address for this computer. This should be in decimal and in dotted quad form (i.e., 192.168.10.253).
- VLAN: Select Enabled to enable IPMI VLAN support. The options are **Enabled** and Disabled.

IPV6 Support

Select Enabled for IPV6 support. The options are **Enabled** and Disabled.

Configuration Address Source

Use this feature to select the IP address source for this computer. If Static is selected, you will need to know the IP address of this computer and enter it to the system manually in the field. If DHCP is selected, AMI BIOS will search for a DHCP (Dynamic Host Configuration Protocol) server attached to the network and request the next available IP address for this computer. The options are **Unspecified**, DHCP and Static.

The following features will be displayed:

- Current Configuration Address Source
- Station IPV6 Address
- Prefix Length
- IPV6 Router1 IP Address
- IPV6 Address Status
- IPV6 DHCP Algorithm

6.6 Security Settings

This menu allows the user to configure the following security settings for the system.

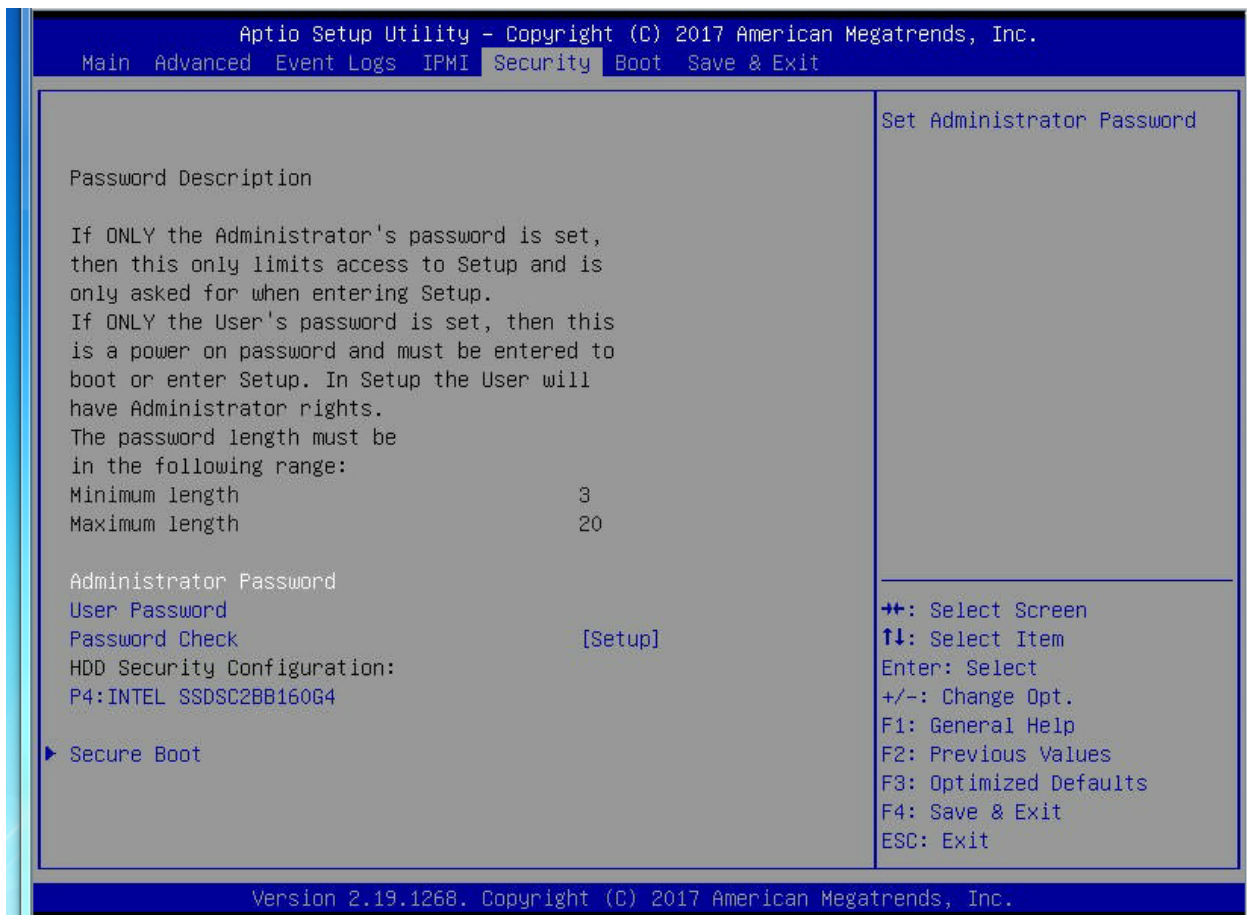

Administrator Password

Use this feature to set the administrator password which is required to enter the BIOS setup utility. The length of the password should be from 3 characters to 20 characters long.

User Password

Use this feature to set the user password which is required to enter the BIOS setup utility. The length of the password should be from 3 characters to 20 characters long.

Password Check

Select Setup for the system to check for a password at Setup. Select Always for the system to check for a password at bootup or upon entering the BIOS Setup utility. The options are **Setup** and **Always**.

HDD Security Configuration:

P4: Intel SSDSC2BB160G4

►Secure Boot

When you select this submenu and press the <Enter> key, the following items will display:

- System Mode
- Secure Boot
- Vendor Keys

Secure Boot

If this feature is set to Enabled, Secure Boot will be activated when a Platform Key (PK) is entered. A Platform Key is a security key used to manage the security settings of the platform firmware used in your system. The options are Enabled and **Disabled**.

Secure Boot Mode

Use this feature to select the desired secure boot mode for the system. The options are Standard and **Custom**.

CMS Support

Select Enabled for CMS support to enhance system performance. The options are **Enabled** and Disabled.

►Key Management

Provision Factory Default Keys

Select Enabled to install all manufacturer default keys to configure the following system security settings. The options are Enabled and **Disabled**.

►Enroll All Factor Defaults

Select Yes to install all manufacturer defaults to configure the following system security settings. The options are **Yes** and No.

►Enroll EFI Image

Select this item and press <Enter> to select an EFI (Extensible Firmware Interface) image for the system to operate in Secure Boot mode.

►Save All Secure Boot Variables

This feature allows the user to set and save the secure boot key variables specified by the user.

►Platform Key (PK)

This feature allows the user to enter and configure a set of values to be used as a platform firmware key for the system. This set of values also indicate the size, the keys numbers, and the key source of the Platform Key. The options are **Save to File**, Set New, and Erase.

►Key Exchange Keys

This feature allows the user to enter and configure a set of values to be used as a Key-Exchange-Keys for the system. This set of values also indicate the size, the keys numbers, and the key source of the Key-Exchange-Keys. The options are **Save to File**, Set New, and Erase.

►Authorized Signatures

This feature allows the user to enter and configure a set of values to be used as Authorized Signatures for the system. These values also indicate the size, the keys numbers, and the key source of the Authorized Signatures. The options are **Set New** and Append.

Secure Boot Variable/Size/Key#/Key Sources The options are **Save to File**, Set New, and Erase.

►Forbidden Signatures

This feature allows the user to enter and configure a set of values to be used as Forbidden Signatures for the system. These values also indicate the size, the keys numbers, and the key source of the Forbidden Signatures. The options are **Save to File**, Set New, and Erase.

►Authorized TimeStamps

This feature allows the user to set and save the timestamps for Authorized Signatures to indicate when these signatures were entered into the system. The options are **Save to File**, Set New, and Erase.

►OsRecovery Signatures

This feature allows the user to set and save the Authorized Signatures used for OS recovery. The options are **Save to File**, Set New, and Erase.

6.7 Boot Settings

Use this feature to configure Boot Settings:

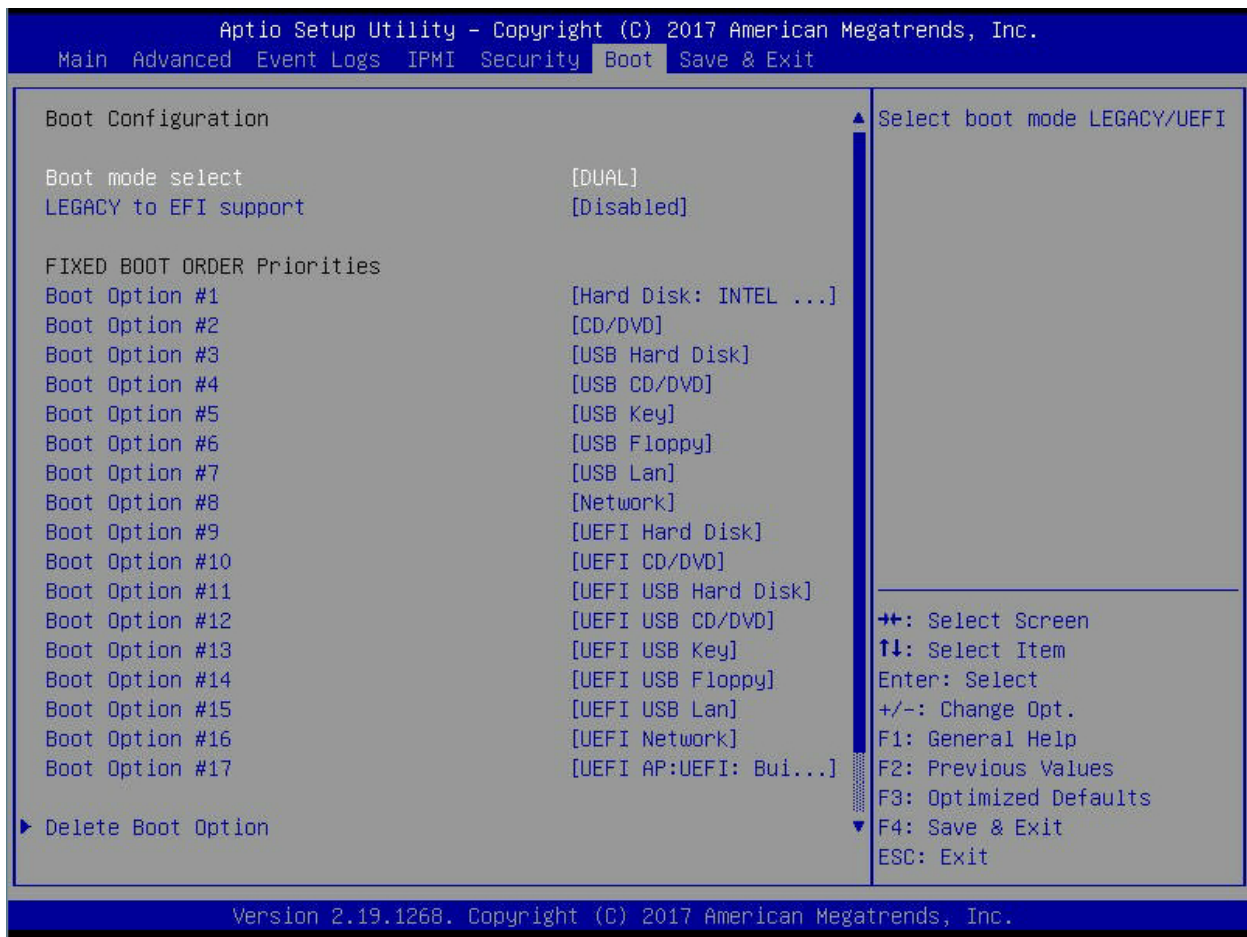

Boot Mode Select

Use this feature to select the type of devices to be used for system boot. The options are Legacy, UEFI (Unified Extensible Firmware Interface), and **Dual**.

Legacy to EFI Support

Select Enabled for the system to boot from an EFI OS when the Legacy OS fails. The options are Enabled and **Disabled**.

Fixed Boot Order Priorities

This feature prioritizes the order of a bootable device from which the system will boot. Press <Enter> on each entry from top to bottom to select devices.

When the item above -"Boot Mode Select" is set to **Dual** (default), the following items will be displayed for configuration:

- Boot Option #1 - Boot Option #15

When the item above -"Boot Mode Select" is set to Legacy, the following items will be display for configuration:

- Boot Option #1 - Boot Option #7

When the item above -"Boot Mode Select" is set to UEFI, the following items will be display for configuration:

- Boot Option #1 - Boot Option #8

Add New Boot Option

This feature allows the user to add a new boot option to the boot priority features for your system.

Add Boot Option

Use this feature to specify the name for the new boot option.

Path for Boot Option

Use this feature to enter the path for the new boot option in the format fsx:\path\filename.efi.

Boot Option File Path

Use this feature to specify the file path for the new boot option.

Create

After the name and the file path for the boot option are set, press <Enter> to create the new boot option in the boot priority list.

►Delete Boot Option

Use this feature to select a boot device to delete from the boot priority list.

Delete Boot Option

Use this feature to remove an EFI boot option from the boot priority list.

►Add New Driver Option

Use this feature to select a new driver to add to the boot priority list.

Add Driver Option

Use this feature to specify the name of the driver that the new boot option is added to.

Path for Drover Option

Use this feature to specify the path to the driver that the new boot option is added to.

Driver Option File Path

Use this feature to specify the file path of the driver that the new boot option is added to.

Create

After the driver option name and the file path are set, press <Enter> to enter to submenu and click OK to create the new boot option drive.

▶ Delete Driver Option

Use this item to select a boot driver to delete from the boot priority list.

Delete Drive Option

Select the target boot driver to delete from the boot priority list.

▶ Hard Disk Drive BBS Priorities

- Boot Option #1 - #5

▶ Network Drive BBS Priorities

- Boot Option #1

▶ USB Key Drive BBS Priorities

- Boot Option #1

▶ UEFI Hard Disk Drive BBS Priorities

- Boot Option #1

▶ UEFI USB Key Drive BBS Priorities

- Boot Option #1

▶ UEFI Application Boot Priorities

- Boot Option #1

6.8 Save & Exit

Select the Save & Exit tab from the BIOS setup screen to configure the settings below.

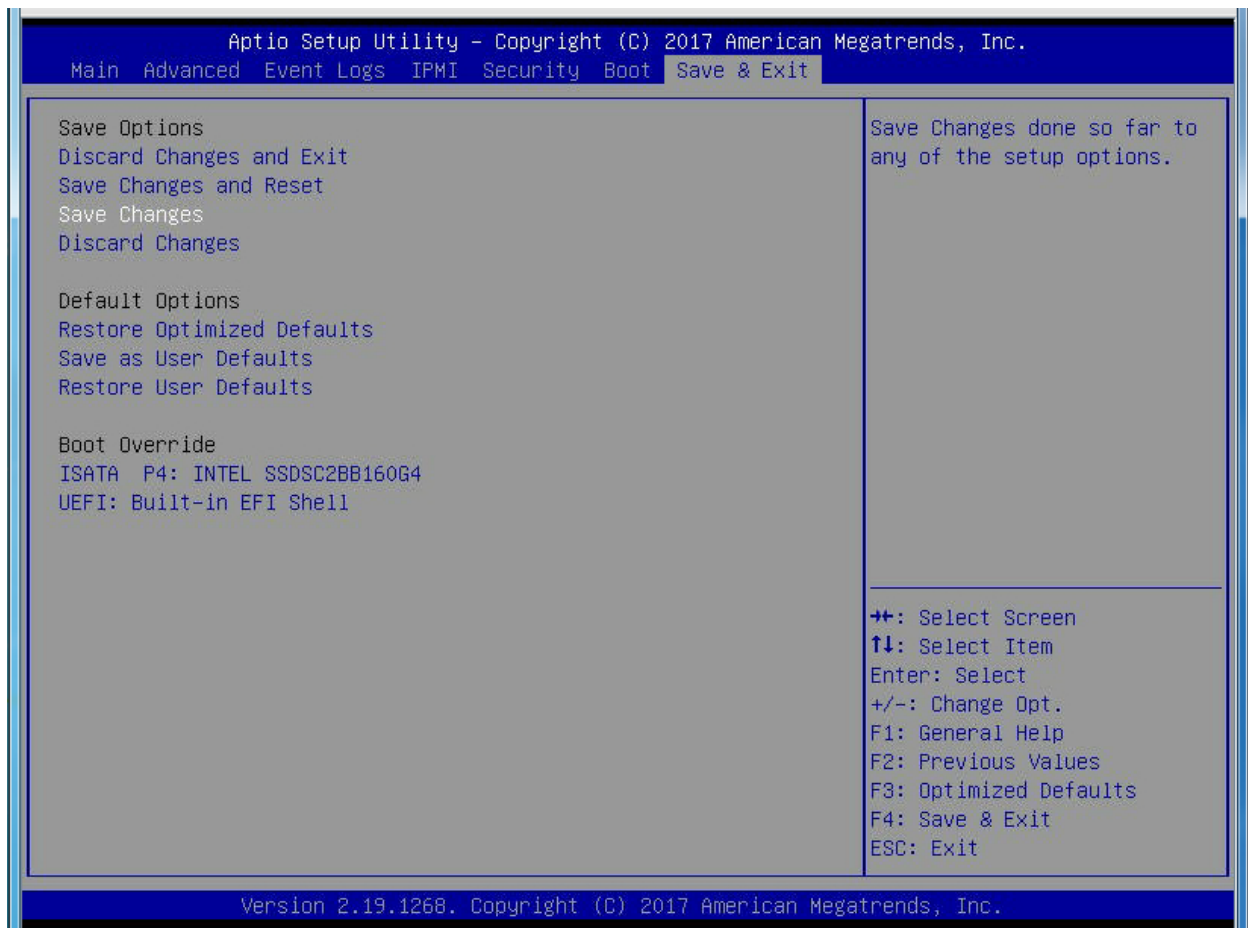

Save Options

Discard Changes and Exit

Select this option to quit the BIOS setup without making any permanent changes to the system configuration and reboot the computer. Select Discard Changes and Exit from the Exit menu and press <Enter>.

Save Changes and Reset

When you have completed the system configuration changes, select this option to leave the BIOS setup utility and reboot the computer for the new system configuration parameters to take effect. Select Save Changes and Exit from the Exit menu and press <Enter>.

Save Changes

When you have completed the system configuration changes, select this option to save all changes made. This will not reset (reboot) the system.

Discard Changes

Select this option and press <Enter> to discard all the changes and return to the AMI BIOS setup utility.

Default Options

Restore Optimized Defaults

To set this feature, select Restore Defaults from the Exit menu and press <Enter> to load manufacturer default settings which are intended for maximum system performance but not for maximum stability.

Save As User Defaults

To set this feature, select Save as User Defaults from the Exit menu and press <Enter>. This enables the user to save any changes to the BIOS setup for future use.

Restore User Defaults

To set this feature, select Restore User Defaults from the Exit menu and press <Enter>. Use this feature to retrieve user-defined settings that were saved previously.

Boot Override

This feature allows the user to override the Boot priorities sequence in the Boot menu, and immediately boot the system with a device specified by the user instead of the one specified in the boot list. This is a one-time override.

Appendix A

BIOS Codes

A.1 BIOS Error POST (Beep) Codes

During the POST (Power-On Self-Test) routines, which are performed each time the system is powered on, errors may occur.

Non-fatal errors are those which, in most cases, allow the system to continue the boot-up process. The error messages normally appear on the screen.

Fatal errors are those which will not allow the system to continue the boot-up procedure. If a fatal error occurs, you should consult with your system manufacturer for possible repairs.

These fatal errors are usually communicated through a series of audible beeps. The numbers on the fatal error list (on the following page) correspond to the number of beeps for the corresponding error.

BIOS Beep (POST) Codes		
Beep Code	Error Message	Description
1 beep	Refresh	Circuits have been reset (Ready to power up)
5 short, 1 long	Memory error	No memory detected in system
5 long, 2 short	Display memory read/write error	Video adapter missing or with faulty memory
1 long continuous	System OH	System overheat condition

A.2 Additional BIOS POST Codes

The AMI BIOS supplies additional checkpoint codes, which are documented online at <http://www.supermicro.com/support/manuals/> ("AMI BIOS POST Codes User's Guide").

When BIOS performs the Power On Self Test, it writes checkpoint codes to I/O port 0080h. If the computer cannot complete the boot process, a diagnostic card can be attached to the computer to read I/O port 0080h (Supermicro p/n AOC-LPC80-20).

For information on AMI updates, please refer to <http://www.ami.com/products/>.

Appendix B

Standardized Warning Statements for AC Systems

B.1 About Standardized Warning Statements

The following statements are industry standard warnings, provided to warn the user of situations which have the potential for bodily injury. Should you have questions or experience difficulty, contact Supermicro's Technical Support department for assistance. Only certified technicians should attempt to install or configure components.

Read this appendix in its entirety before installing or configuring components in the Supermicro chassis.

These warnings may also be found on our website at http://www.supermicro.com/about/policies/safety_information.cfm.

Warning Definition



Warning! This warning symbol means danger. You are in a situation that could cause bodily injury. Before you work on any equipment, be aware of the hazards involved with electrical circuitry and be familiar with standard practices for preventing accidents.

警告の定義

この警告サインは危険を意味します。

人身事故につながる可能性がありますので、いずれの機器でも動作させる前に、電気回路に含まれる危険性に注意して、標準的な事故防止策に精通して下さい。

此警告符号代表危險。

您正处于可能受到严重伤害的工作环境中。在您使用设备开始工作之前，必须充分意识到触电的危险，并熟练掌握防止事故发生的标准工作程序。请根据每项警告结尾的声明号码找到此设备的安全性警告说明的翻译文本。

此警告符號代表危險。

您目前所處的工作環境可能讓您受傷。在您使用任何設備之前，請注意觸電的危險，並且要熟悉預防事故發生的標準工作程序。請依照每一注意事項後的號碼找到相關的翻譯說明內容。

Warnung

WICHTIGE SICHERHEITSHINWEISE

Dieses Warnsymbol bedeutet Gefahr. Sie befinden sich in einer Situation, die zu Verletzungen führen kann. Machen Sie sich vor der Arbeit mit Geräten mit den Gefahren elektrischer Schaltungen und den üblichen Verfahren zur Vorbeugung vor Unfällen vertraut. Suchen Sie mit der am Ende jeder Warnung angegebenen Anweisungsnummer nach der jeweiligen Übersetzung in den übersetzten Sicherheitshinweisen, die zusammen mit diesem Gerät ausgeliefert wurden.

BEWAHREN SIE DIESE HINWEISE GUT AUF.

INSTRUCCIONES IMPORTANTES DE SEGURIDAD

Este símbolo de aviso indica peligro. Existe riesgo para su integridad física. Antes de manipular cualquier equipo, considere los riesgos de la corriente eléctrica y familiarícese con los procedimientos estándar de prevención de accidentes. Al final de cada advertencia encontrará el número que le ayudará a encontrar el texto traducido en el apartado de traducciones que acompaña a este dispositivo.

GUARDE ESTAS INSTRUCCIONES.

IMPORTANTES INFORMATIONS DE SÉCURITÉ

Ce symbole d'avertissement indique un danger. Vous vous trouvez dans une situation pouvant entraîner des blessures ou des dommages corporels. Avant de travailler sur un équipement, soyez conscient des dangers liés aux circuits électriques et familiarisez-vous avec les procédures couramment utilisées pour éviter les accidents. Pour prendre connaissance des traductions des avertissements figurant dans les consignes de sécurité traduites qui accompagnent cet appareil, référez-vous au numéro de l'instruction situé à la fin de chaque avertissement.

CONSERVEZ CES INFORMATIONS.

תקנון הזהרות אזהרה

הזהרות הבאות הן אזהרות על פי תקני התעשייה, על מנת להזהיר את המשתמש מפני חבלה פיזית אפשרית. במידה ויש שאלות או היתקלות בבעיה כלשהי, יש ליצור קשר עם מחלקת תמיכה טכנית של סופרמיקרו. טכנאים מוסמכים בלבד רשאים להתקין או להגדיר את הרכיבים. יש לקרוא את הנספח במלואו לפני התקנת או הגדרת הרכיבים במארזי סופרמיקרו.

اَكْ ف حالة وُكِي اَي تتسبب ف اصابة جسدهُ هذا الزهز عُ خطر! تحذُرُ .
قبل اَي تعول على اَي هعدات، كي على علن بالوخاطز ال اُجوة عي الذوائر
الكهزبائِة
وكي على دراةُ بالووارسات النقاائِة لو عُ وقع اَي حادث
استخدم رِقن الب اِي الو صُص ف هاةُ كل تحذُرُ للعشر تزجوتها

안전을 위한 주의사항

경고!

이 경고 기호는 위험이 있음을 알려 줍니다. 작업자의 신체에 부상을 야기 할 수 있는 상태에 있게 됩니다. 모든 장비에 대한 작업을 수행하기 전에 전기회로와 관련된 위험요소들을 확인하시고 사전에 사고를 방지할 수 있도록 표준 작업절차를 준수해 주시기 바랍니다.

해당 번역문을 찾기 위해 각 경고의 마지막 부분에 제공된 경고문 번호를 참조하십시오

BELANGRIJKE VEILIGHEIDSINSTRUCTIES

Dit waarschuwings symbool betekent gevaar. U verkeert in een situatie die lichamelijk letsel kan veroorzaken. Voordat u aan enige apparatuur gaat werken, dient u zich bewust te zijn van de bij een elektrische installatie betrokken risico's en dient u op de hoogte te zijn van de standaard procedures om ongelukken te voorkomen. Gebruik de nummers aan het eind van elke waarschuwing om deze te herleiden naar de desbetreffende locatie.

BEWAAR DEZE INSTRUCTIES

Installation Instructions



Warning! Read the installation instructions before connecting the system to the power source.

設置手順書

システムを電源に接続する前に、設置手順書をお読み下さい。

警告

将此系统连接电源前,请先阅读安装说明。

警告

將系統與電源連接前，請先閱讀安裝說明。

Warnung

Vor dem Anschließen des Systems an die Stromquelle die Installationsanweisungen lesen.

¡Advertencia!

Lea las instrucciones de instalación antes de conectar el sistema a la red de alimentación.

Attention

Avant de brancher le système sur la source d'alimentation, consulter les directives d'installation.

יש לקרוא את הוראות התקנה לפני חיבור המערכת למקור מתח.

اقرأ إرشادات التركيب قبل توصيل النظام إلى مصدر للطاقة

시스템을 전원에 연결하기 전에 설치 안내를 읽어주십시오.

Waarschuwing

Raadpleeg de installatie-instructies voordat u het systeem op de voedingsbron aansluit.

Circuit Breaker



Warning! This product relies on the building's installation for short-circuit (overcurrent) protection. Ensure that the protective device is rated not greater than: 250 V, 20 A.

サーキット・ブレーカー

この製品は、短絡(過電流)保護装置がある建物での設置を前提としています。

保護装置の定格が250 V、20 Aを超えないことを確認下さい。

警告

此产品的短路(过载电流)保护由建筑物的供电系统提供,确保短路保护设备的额定电流不大于250V,20A。

警告

此產品的短路(過載電流)保護由建築物的供電系統提供,確保短路保護設備的額定電流不大於250V,20A。

Warnung

Dieses Produkt ist darauf angewiesen, dass im Gebäude ein Kurzschluss- bzw. Überstromschutz installiert ist. Stellen Sie sicher, dass der Nennwert der Schutzvorrichtung nicht mehr als: 250 V, 20 A beträgt.

¡Advertencia!

Este equipo utiliza el sistema de protección contra cortocircuitos (o sobrecorrientes) del edificio. Asegúrese de que el dispositivo de protección no sea superior a: 250 V, 20 A.

Attention

Pour ce qui est de la protection contre les courts-circuits (surtension), ce produit dépend de l'installation électrique du local. Vérifiez que le courant nominal du dispositif de protection n'est pas supérieur à :250 V, 20 A.

מוצר זה מסתמך על הגנה המותקנת במבנים למניעת קצר חשמלי. יש לוודא כי המכשיר המגן מפני הקצר החשמלי הוא לא יותר מ-250VDC, 20A

هذا المنتج يعتمد على معدات الحماية من الدوائر القصيرة التي تم تثبيتها في المبنى
تأكد من أن تقييم الجهاز الوقائي ليس أكثر من : 20A, 250V

경고!

이 제품은 전원의 단락(과전류)방지에 대해서 전적으로 건물의 관련 설비에 의존합니다. 보호장치의 정격이 반드시 250V(볼트), 20A(암페어)를 초과하지 않도록 해야 합니다.

Waarschuwing

Dit product is afhankelijk van de kortsluitbeveiliging (overspanning) van uw elektrische installatie. Controleer of het beveiligde apparaat niet groter gedimensioneerd is dan 250V, 20A.

Power Disconnection Warning



Warning! The system must be disconnected from all sources of power and the power cord removed from the power supply module(s) before accessing the chassis interior to install or remove system components.

電源切断の警告

システムコンポーネントの取り付けまたは取り外しのために、シャーシ内部にアクセスするには、システムの電源はすべてのソースから切断され、電源コードは電源モジュールから取り外す必要があります。

警告

在你打开机箱并安装或移除内部器件前,必须将系统完全断电,并移除电源线。

警告

在您打開機殼安裝或移除內部元件前，必須將系統完全斷電，並移除電源線。

Warnung

Das System muss von allen Quellen der Energie und vom Netzanschlusskabel getrennt sein, das von den Spg.Versorgungsteilmodulen entfernt wird, bevor es auf den Chassisinnenraum zurückgreift, um Systemsbestandteile anzubringen oder zu entfernen.

¡Advertencia!

El sistema debe ser disconnected de todas las fuentes de energía y del cable eléctrico quitado de los módulos de fuente de alimentación antes de tener acceso el interior del chasis para instalar o para quitar componentes de sistema.

Attention

Le système doit être débranché de toutes les sources de puissance ainsi que de son cordon d'alimentation secteur avant d'accéder à l'intérieur du chasis pour installer ou enlever des composants de système.

אזהרה מפני ניתוק חשמלי

אזהרה!

יש לנתק את המערכת מכל מקורות החשמל ויש להסיר את כבל החשמלי מהספק לפני גישה לחלק הפנימי של המארז לצורך התקנת או הסרת רכיבים.

يجب فصل انظاؤ من جميع مصادر انطاقت وإزانت سهك انكهرباء من وحدة امداد
انطاقت قېم
انصل إلى امناطق انداخييت نههيكم نتشيج أو إزانت مكناث الجهاز

경고!

시스템에 부품들을 장착하거나 제거하기 위해서는 새시 내부에 접근하기 전에 반드시 전원 공급장치로부터 연결되어있는 모든 전원과 전기코드를 분리해주어야 합니다.

Waarschuwing

Voordat u toegang neemt tot het binnenwerk van de behuizing voor het installeren of verwijderen van systeem onderdelen, dient u alle spanningsbronnen en alle stroomkabels aangesloten op de voeding(en) van de behuizing te verwijderen

Equipment Installation



Warning! Only trained and qualified personnel should be allowed to install, replace, or service this equipment.

機器の設置

トレーニングを受け認定された人だけがこの装置の設置、交換、またはサービスを許可されていません。

警告

只有经过培训且具有资格的人员才能进行此设备的安装、更换和维修。

警告

只有經過受訓且具資格人員才可安裝、更換與維修此設備。

Warnung

Das Installieren, Ersetzen oder Bedienen dieser Ausrüstung sollte nur geschultem, qualifiziertem Personal gestattet werden.

¡Advertencia!

Solamente el personal calificado debe instalar, reemplazar o utilizar este equipo.

Attention

Il est vivement recommandé de confier l'installation, le remplacement et la maintenance de ces équipements à des personnels qualifiés et expérimentés.

אזהרה!

צוות מוסמך בלבד רשאי להתקין, להחליף את הציוד או לתת שירות עבור הציוד.

والمدربيه لتزكيب واستبدال أو خدمة هذا الجهاز يجب أن يسمح فقط للمظفيه المؤهليه

경고!

훈련을 받고 공인된 기술자만이 이 장비의 설치, 교체 또는 서비스를 수행할 수 있습니다.

Waarschuwing

Deze apparatuur mag alleen worden geïnstalleerd, vervangen of hersteld door geschoold en gekwalificeerd personeel.

Restricted Area

Warning! This unit is intended for installation in restricted access areas. A restricted access area can be accessed only through the use of a special tool, lock and key, or other means of security. (This warning does not apply to workstations).

アクセス制限区域

このユニットは、アクセス制限区域に設置されることを想定しています。

アクセス制限区域は、特別なツール、鍵と錠前、その他のセキュリティの手段を用いてのみ出入りが可能です。

警告

此部件应安装在限制进出的场所，限制进出的场所指只能通过使用特殊工具、锁和钥匙或其它安全手段进出的场所。

警告

此装置仅限安装於進出管制區域，進出管制區域係指僅能以特殊工具、鎖頭及鑰匙或其他安全方式才能進入的區域。

Warnung

Diese Einheit ist zur Installation in Bereichen mit beschränktem Zutritt vorgesehen. Der Zutritt zu derartigen Bereichen ist nur mit einem Spezialwerkzeug, Schloss und Schlüssel oder einer sonstigen Sicherheitsvorkehrung möglich.

¡Advertencia!

Esta unidad ha sido diseñada para instalación en áreas de acceso restringido. Sólo puede obtenerse acceso a una de estas áreas mediante la utilización de una herramienta especial, cerradura con llave u otro medio de seguridad.

Attention

Cet appareil doit être installée dans des zones d'accès réservés. L'accès à une zone d'accès réservé n'est possible qu'en utilisant un outil spécial, un mécanisme de verrouillage et une clé, ou tout autre moyen de sécurité.

אזור עם גישה מוגבלת

אזהרה!

יש להתקין את היחידה באזורים שיש בהם הגבלת גישה. הגישה ניתנת בעזרת 'כלי אבטחה בלבד' (מפתח, מנעול וכד.).

تخصيص هذه انحدة نترك بُها ف مناطق محظورة تم .
،مکن انصلل إن منطقت محظورة فقط من خلال استخذاو أداة خاصت
أو أ وس هُت أخري نلالأمما ققم ومفتاح

경고!

이 장치는 접근이 제한된 구역에 설치하도록 되어있습니다. 특수도구, 잠금 장치 및 키, 또는 기타 보안 수단을 통해서만 접근 제한 구역에 들어갈 수 있습니다.

Waarschuwing

Dit apparaat is bedoeld voor installatie in gebieden met een beperkte toegang. Toegang tot dergelijke gebieden kunnen alleen verkregen worden door gebruik te maken van speciaal gereedschap, slot en sleutel of andere veiligheidsmaatregelen.

Battery Handling



Warning! There is the danger of explosion if the battery is replaced incorrectly. Replace the battery only with the same or equivalent type recommended by the manufacturer. Dispose of used batteries according to the manufacturer's instructions

電池の取り扱い

電池交換が正しく行われなかった場合、破裂の危険性があります。交換する電池はメーカーが推奨する型、または同等のものを使用下さい。使用済電池は製造元の指示に従って処分して下さい。

警告

電池更換不當會有爆炸危險。請只使用同類電池或制造商推薦的功能相當的電池更換原有電池。請按製造商的說明處理廢舊電池。

警告

電池更換不當會有爆炸危險。請使用製造商建議之相同或功能相當的電池更換原有電池。請按照製造商的說明指示處理廢棄舊電池。

Warnung

Bei Einsetzen einer falschen Batterie besteht Explosionsgefahr. Ersetzen Sie die Batterie nur durch den gleichen oder vom Hersteller empfohlenen Batterietyp. Entsorgen Sie die benutzten Batterien nach den Anweisungen des Herstellers.

Attention

Danger d'explosion si la pile n'est pas remplacée correctement. Ne la remplacer que par une pile de type semblable ou équivalent, recommandée par le fabricant. Jeter les piles usagées conformément aux instructions du fabricant.

¡Advertencia!

Existe peligro de explosión si la batería se reemplaza de manera incorrecta. Reemplazar la batería exclusivamente con el mismo tipo o el equivalente recomendado por el fabricante. Desechar las baterías gastadas según las instrucciones del fabricante.

אזהרה!

קיימת סכנת פיצוץ של הסוללה במידה והוחלפה בדרך לא תקינה. יש להחליף את הסוללה בסוג התואם מחברת יצרן מומלצת. סילוק הסוללות המשומשות יש לבצע לפי הוראות היצרן.

هناك خطر من انفجار في حالة اسبدال البطارية بطريقة غير صحيحة فعلى
اسبدال البطارية
فقط بنفس النوع أو ما يعادلها مما أوصت به الشركة المصنعة
جخلص من البطاريات المسحومة وفقا لعمليات الشركة الصانعة

경고!

배터리가 올바르게 교체되지 않으면 폭발의 위험이 있습니다. 기존 배터리와 동일하거나 제조사에서 권장하는 동등한 종류의 배터리로만 교체해야 합니다. 제조사의 안내에 따라 사용된 배터리를 처리하여 주십시오.

Waarschuwing

Er is ontplofingsgevaar indien de batterij verkeerd vervangen wordt. Vervang de batterij slechts met hetzelfde of een equivalent type die door de fabrikant aanbevolen wordt. Gebruikte batterijen dienen overeenkomstig fabrieksvoorschriften afgevoerd te worden.

Redundant Power Supplies



Warning! This unit might have more than one power supply connection. All connections must be removed to de-energize the unit.

冗長電源装置

このユニットは複数の電源装置が接続されている場合があります。

ユニットの電源を切るためには、すべての接続を取り外さなければなりません。

警告

此部件连接的电源可能不止一个，必须将所有电源断开才能停止给该部件供电。

警告

此装置连接的电源可能不只一个，必须切断所有电源才能停止对该装置的供电。

Warnung

Dieses Gerät kann mehr als eine Stromzufuhr haben. Um sicherzustellen, dass der Einheit kein Strom zugeführt wird, müssen alle Verbindungen entfernt werden.

¡Advertencia!

Puede que esta unidad tenga más de una conexión para fuentes de alimentación. Para cortar por completo el suministro de energía, deben desconectarse todas las conexiones.

Attention

Cette unité peut avoir plus d'une connexion d'alimentation. Pour supprimer toute tension et tout courant électrique de l'unité, toutes les connexions d'alimentation doivent être débranchées.

אם קיים יותר מספק אחד

אזהרה!

ליחידה יש יותר מחיבור אחד של ספק. יש להסיר את כל החיבורים על מנת לרוקן את היחידה.

قد يكون لهذا الجهاز عدة اتصالات بوحدات امداد الطاقة .

يجب إزالة كافة الاتصالات لعسل الوحدة عن الكهرباء

경고!

이 장치에는 한 개 이상의 전원 공급 단자가 연결되어 있을 수 있습니다. 이 장치에 전원을 차단하기 위해서는 모든 연결 단자를 제거해야만 합니다.

Waarschuwing

Deze eenheid kan meer dan één stroomtoevoeraansluiting bevatten. Alle aansluitingen dienen verwijderd te worden om het apparaat stroomloos te maken.

Backplane Voltage



Warning! Hazardous voltage or energy is present on the backplane when the system is operating. Use caution when servicing.

バックプレーンの電圧

システムの稼働中は危険な電圧または電力が、バックプレーン上にかかっています。

修理する際には注意ください。

警告

当系统正在进行时，背板上有很危险的电压或能量，进行维修时务必小心。

警告

當系統正在進行時，背板上危險的電壓或能量，進行維修時務必小心。

Warnung

Wenn das System in Betrieb ist, treten auf der Rückwandplatine gefährliche Spannungen oder Energien auf. Vorsicht bei der Wartung.

¡Advertencia!

Cuando el sistema está en funcionamiento, el voltaje del plano trasero es peligroso. Tenga cuidado cuando lo revise.

Attention

Lorsque le système est en fonctionnement, des tensions électriques circulent sur le fond de panier. Prendre des précautions lors de la maintenance.

מתח בפנל האחורי

אזהרה!

קיימת סכנת מתח בפנל האחורי בזמן תפעול המערכת. יש להיזהר במהלך העבודה.

هناك خطر من التيار الكهربائي أو الطاقة المتجددة على اللوحة
عندما يكون النظام يعمل كه حذرا عند خدمة هذا الجهاز

경고!

시스템이 동작 중일 때 후면판 (Backplane)에는 위험한 전압이나 에너지가 발생 합니다.
서비스 작업 시 주의하십시오.

Waarschuwing

Een gevaarlijke spanning of energie is aanwezig op de backplane wanneer het systeem in gebruik is. Voorzichtigheid is geboden tijdens het onderhoud.

Comply with Local and National Electrical Codes



Warning! Installation of the equipment must comply with local and national electrical codes.

地方および国の電気規格に準拠

機器の取り付けはその地方および国の電気規格に準拠する必要があります。

警告

设备安装必须符合本地与本国电气法规。

警告

設備安裝必須符合本地與本國電氣法規。

Warnung

Die Installation der Geräte muss den Sicherheitsstandards entsprechen.

¡Advertencia!

La instalación del equipo debe cumplir con las normas de electricidad locales y nacionales.

Attention

L'équipement doit être installé conformément aux normes électriques nationales et locales.

תיאום חוקי החשמל הארצי

אזהרה!

התקנת הציוד חייבת להיות תואמת לחוקי החשמל המקומיים והארציים.

تركيب المعدات الكهربائية يجب أن يمتثل للقوايه المحلية والبطية المتعلقة

بالكهرباء

경고!

현 지역 및 국가의 전기 규정에 따라 장비를 설치해야 합니다.

Waarschuwing

Bij installatie van de apparatuur moet worden voldaan aan de lokale en nationale elektriciteitsvoorschriften.

Product Disposal



Warning! Ultimate disposal of this product should be handled according to all national laws and regulations.

製品の廃棄

この製品を廃棄処分する場合、国の関係する全ての法律・条例に従い処理する必要があります。

警告

本产品的废弃处理应根据所有国家的法律和规章进行。

警告

本產品的廢棄處理應根據所有國家的法律和規章進行。

Warnung

Die Entsorgung dieses Produkts sollte gemäß allen Bestimmungen und Gesetzen des Landes erfolgen.

¡Advertencia!

Al deshacerse por completo de este producto debe seguir todas las leyes y reglamentos nacionales.

Attention

La mise au rebut ou le recyclage de ce produit sont généralement soumis à des lois et/ou directives de respect de l'environnement. Renseignez-vous auprès de l'organisme compétent.

סילוק המוצר

אזהרה!

סילוק סופי של מוצר זה חייב להיות בהתאם להנחיות וחוקי המדינה.

التخلص النهائي من هذا المنتج ينبغي التعامل معه وفقا لجميع القوانين واللوائح الوطنية عند

경고!

이 제품은 해당 국가의 관련 법규 및 규정에 따라 폐기되어야 합니다.

Waarschuwing

De uiteindelijke verwijdering van dit product dient te geschieden in overeenstemming met alle nationale wetten en reglementen.

Hot Swap Fan Warning



Warning! Hazardous moving parts. Keep away from moving fan blades. The fans might still be turning when you remove the fan assembly from the chassis. Keep fingers, screwdrivers, and other objects away from the openings in the fan assembly's housing.

ファン・ホットスワップの警告

警告!回転部品に注意。運転中は回転部(羽根)に触れないでください。シャーシから冷却ファン装置を取り外した際、ファンがまだ回転している可能性があります。ファンの開口部に、指、ドライバー、およびその他のものを近づけないで下さい。

警告!

警告! 危險的可移動性零件。請務必與轉動的风扇叶片保持距離。當您從機架移除風扇裝置，風扇可能仍在轉動。小心不要將手指、螺絲起子和其他物品太靠近風扇

警告

危險的可移動性零件。請務必與轉動的风扇叶片保持距離。當您從機架移除風扇裝置，風扇可能仍在轉動。小心不要將手指、螺絲起子和其他物品太靠近風扇。

Warnung

Gefährlich Bewegende Teile. Von den bewegenden Lüfterblätter fern halten. Die Lüfter drehen sich u. U. noch, wenn die Lüfterbaugruppe aus dem Chassis genommen wird. Halten Sie Finger, Schraubendreher und andere Gegenstände von den Öffnungen des Lüftergehäuses entfernt.

¡Advertencia!

Riesgo de piezas móviles. Mantener alejado de las aspas del ventilador. Los ventiladores podran dar vuelta cuando usted quite el montaje del ventilador del chasis. Mantenga los dedos, los destornilladores y todos los objetos lejos de las aberturas del ventilador

Attention

Pieces mobiles dangereuses. Se tenir a l'écart des lames du ventilateur Il est possible que les ventilateurs soient toujours en rotation lorsque vous retirerez le bloc ventilateur du châssis. Prenez garde à ce que doigts, tournevis et autres objets soient éloignés du logement du bloc ventilateur.

אזהרה!

חלקים נעים מסוכנים. התרחק מלהבי המאוורר בפעולה כאשר מסירים את חלקי המאוורר מהמארז, יתכן והמאווררים עדיין עובדים. יש להרחיק למרחק בטוח את האצבעות וכלי עבודה שונים מהפתחים בתוך המאוורר

تحذير! أجزاء متحركة خطيرة. ابتعد عن شفرات المروحة المتحركة. من الممكن أن المراوح لا تزال تدور عند إزالة كتلة المروحة من الهيكل يجب إبقاء الأصابع ومفكات البراغي وغيرها من الأشياء بعيدا عن الفتحات في كتلة المروحة

경고!

움직이는 위험한 부품. 회전하는 송풍 날개에 접근하지 마세요. 새시로부터 팬 조립품을 제거할 때 팬은 여전히 회전하고 있을 수 있습니다. 팬 조립품 외관의 열려있는 부분들로부터 손가락 및 스크류드라이버, 다른 물체들이 가까이 하지 않도록 배치해 주십시오.

Waarschuwing

Gevaarlijk bewegende onderdelen. Houd voldoende afstand tot de bewegende ventilatorbladen. Het is mogelijk dat de ventilator nog draait tijdens het verwijderen van het ventilatorsamenstel uit het chassis. Houd uw vingers, schroevendraaiers en eventuele andere voorwerpen uit de buurt van de openingen in de ventilatorbehuizing.

Power Cable and AC Adapter



Warning! When installing the product, use the provided or designated connection cables, power cables and AC adapters. Using any other cables and adapters could cause a malfunction or a fire. Electrical Appliance and Material Safety Law prohibits the use of UL or CSA -certified cables (that have UL/CSA shown on the code) for any other electrical devices than products designated by Supermicro only.

電源コードとACアダプター

製品を設置する場合、提供または指定および購入された接続ケーブル、電源コードとACアダプターを該当する地域の条例や安全基準に適合するコードサイズやプラグと共に使用下さい。他のケーブルやアダプタを使用すると故障や火災の原因になることがあります。

電気用品安全法は、ULまたはCSA認定のケーブル(UL/CSEマークがコードに表記)を Supermicro が指定する製品以外に使用することを禁止しています。

警告

安装此产品时,请使用本身提供的或指定的或采购的连接线,电源线和电源适配器。包含遵照当地法规和安全要求的合规的电源线尺寸和插头。使用其它线材或适配器可能会引起故障或火灾。除了Supermicro所指定的产品,电气用品和材料安全法律规定禁止使用未经UL或CSA认证的线材。(线材上会显示UL/CSA符号)。

警告

安裝此產品時,請使用本身提供的或指定的或採購的連接線,電源線和電源適配器。包含遵照當地法規和安全要求的合規的電源線尺寸和插頭。使用其它線材或適配器可能會引起故障或火災。除了Supermicro所指定的產品,電氣用品和材料安全法律規定禁止使用未經UL或CSA認證的線材。(線材上會顯示UL/CSA符號)。

Warnung

Nutzen Sie beim Installieren des Produkts ausschließlich die von uns zur Verfügung gestellten Verbindungskabeln, Stromkabeln und/oder Adapter, die Ihre örtlichen Sicherheitsstandards einhalten. Der Gebrauch von anderen Kabeln und Adapter können Fehlfunktionen oder Feuer verursachen. Die Richtlinien untersagen das Nutzen von UL oder CAS zertifizierten Kabeln (mit UL/CSA gekennzeichnet), an Geräten oder Produkten die nicht mit Supermicro gekennzeichnet sind.

전원 케이블 및 AC 어댑터

경고! 제품을 설치할 때 현지 코드 및 적절한 굵기의 코드와 플러그를 포함한 안전 요구 사항을 준수하여 제공되거나 지정된 연결 혹은 구매 케이블, 전원 케이블 및 AC 어댑터를 사용하십시오.

다른 케이블이나 어댑터를 사용하면 오작동이나 화재가 발생할 수 있습니다. 전기 용품 안전법은 UL 또는 CSA 인증 케이블 (코드에 UL / CSA가 표시된 케이블)을 Supermicro가 지정한 제품 이외의 전기 장치에 사용하는 것을 금지합니다.

Stroomkabel en AC-Adapter

Waarschuwing! Bij het aansluiten van het Product uitsluitend gebruik maken van de geleverde Kabels of een andere geschikte aan te schaffen Aansluitmethode, deze moet altijd voldoen aan de lokale voorschriften en veiligheidsnormen, inclusief de juiste kabeldikte en stekker. Het gebruik van niet geschikte Kabels en/of Adapters kan een storing of brand veroorzaken. Wetgeving voor Elektrische apparatuur en Materiaalveiligheid verbied het gebruik van UL of CSA -gecertificeerde Kabels (met UL/CSA in de code) voor elke andere toepassing dan de door Supermicro hiervoor beoogde Producten.

Appendix C

System Specifications

Processors

Dual Intel® Xeon Socket P0 (LGA 3647) Intel® Xeon 81xx/61xx/51xx/41xx/31xx and 82xx/62xx/52xx/42xx/32xx series supported processors

Note: The 1029TP-DTR/DC0R/DC1R system does not support Omni-Path Fabric CPUs.

Chipset

Intel C621 chipset

BIOS

128 Mb AMI® Flash ROM

Memory

Integrated memory controller supports up to 2 TB of LRDIMM/RDIMM/NVDIMM DDR4 (288-pin) ECC 2933/2666/2400/2133/1866/1600/1333 MHz modules in sixteen (16) slots at up to 128GB at 1.2V.

Note: For the latest CPU/memory updates, please refer to our website at <http://www.supernmicro.com/products/motherboard>.

SATA Controller

On-chip (Intel C621) controller

Drive Bays

Up to four hot-swap drive bays per node (eight total)

PCI Expansion Slots

The following PCI-E slots are available on the serverboard:

- One PCI-Express 3.0 x8 slot supported by CPU1 (SXB1)
- One PCI-Express 3.0 x16 slot supported by CPU2 (SXB2)
- One PCI-Express 3.0 x16 slot supported by CPU1 (SXB3_1)
- One PCI-Express 3.0 x8 slot supported by CPU2 (SXB3_2)
- One PCI-E 3.0 x16 slot supported by CPU2 (SXB4)

Motherboard

X11DPT-PS; Micro ATX form factor: 6.8" x 18.86" (172.7 mm x 479 mm)

Chassis

SC809H-R1K05P3; 1U Rackmount,

Dimensions: (WxHxD) 17.2 x 1.75 x 28.25 in. (437 x 45 x 718 mm)

System Cooling

Up to six 4-cm PWM fans per noded

Power Supply

Model: PWS-1K05A-1R

AC Input Voltages: 100 - 240V AC auto-range

Rated Input Current: 9-5A

Rated Input Frequency: 50 to 60 Hz

Rated Output Power: 1000 Watt

Rated Output Voltages: +12V: 66.7A (100Vac-127Vac) or 83A (200Vac-240Vac), +5V Standby: Max: 4A

Operating Environment

Operating Temperature: 10°C to 35°C (50°F to 95°F)

Expanded Operating Temperature: 5°C to 40°C (41°F to 104°F)

Non-Operating Temperature: -40°C to 60°C (-40°F to 140°F)

Operating Relative Humidity: 8% to 90% (non-condensing)

Non-Operating Relative Humidity: 5% to 95% (non-condensing)

Regulatory Compliance

Electromagnetic Emissions: FCC Class A, EN 55032 Class A, EN 61000-3-2/3-3, CISPR 32 Class A

Electromagnetic Immunity: EN 55024/CISPR 24, (EN 61000-4-2, EN 61000-4-3, EN 61000-4-4, EN 61000-4-5, EN 61000-4-6, EN 61000-4-8, EN 61000-4-11), CNS14336-1, CNS13438, GB4943.1-2011, GB9254-2008(Class A) and GB17625.1-2012

Safety: CSA/EN/IEC/UL 60950-1 Compliant, UL or CSA Listed (USA and Canada), CE Marking (Europe)

Other: VCCI-CISPR 32 and AS/NZS CISPR 32

Environmental: Directive 2011/65/EU and Delegated Directive (EU) 2015/863 and Directive 2012/19/EU

Perchlorate Warning

California Best Management Practices Regulations for Perchlorate Materials: This Perchlorate warning applies only to products containing CR (Manganese Dioxide) Lithium coin cells. "Perchlorate Material-special handling may apply. See www.dtsc.ca.gov/hazardouswaste/perchlorate"

Appendix D

UEFI BIOS Recovery

Warning: Do not upgrade the BIOS unless your system has a BIOS-related issue. Flashing the wrong BIOS can cause irreparable damage to the system. In no event shall Supermicro be liable for direct, indirect, special, incidental, or consequential damages arising from a BIOS update. If you need to update the BIOS, do not shut down or reset the system while the BIOS is updating to avoid possible boot failure.

D.1 Overview

The Unified Extensible Firmware Interface (UEFI) provides a software-based interface between the operating system and the platform firmware in the pre-boot environment. The UEFI specification supports an architecture-independent mechanism that will allow the UEFI OS loader stored in an add-on card to boot the system. The UEFI offers clean, hands-off management to a computer during system boot.

D.2 Recovering the UEFI BIOS Image

A UEFI BIOS flash chip consists of a recovery BIOS block and a main BIOS block (a main BIOS image). The boot block contains critical BIOS codes, including memory detection and recovery codes for the user to flash a new BIOS image if the original main BIOS image is corrupted. When the system power is first turned on, the boot block codes execute first. Once this process is completed, the main BIOS code will continue with system initialization and the remaining POST (Power-On Self-Test) routines.

Note 1: Follow the BIOS recovery instructions below for BIOS recovery when the main BIOS boot crashes.

Note 2: When the BIOS boot block crashes, you will need to follow the procedures to make a Returned Merchandise Authorization (RMA) request. (For a RMA request, please see section 3.5 for more information). Also, you may use the Supermicro Update Manager (SUM) Out-of-Band (OOB) (https://www.supermicro.com.tw/products/nfo/SMS_SUM.cfm) to reflash the BIOS.

D.3 Recovering the BIOS Block with a USB Device

This feature allows the user to recover a BIOS image using a USB-attached device without additional utilities used. A USB flash device such as a USB Flash Drive, or a USB CD/DVD ROM/RW device can be used for this purpose. However, a USB Hard Disk drive cannot be used for BIOS recovery at this time.

The file system supported by UEFI is FAT (including FAT12, FAT16, and FAT32) which is installed on a bootable or non-bootable USB-attached device. However, the BIOS might need several minutes to locate the SUPER.ROM file if the media size becomes too large due to the huge volumes of folders and files stored in the device.

To perform UEFI BIOS recovery using a USB-attached device, follow the instructions below.

1. Using a different machine, copy the "Super.ROM" binary image file into the disc Root "\" directory of a USB device or a writable CD/DVD.

Note: If you cannot locate the "Super.ROM" file in your driver disk, visit our website at www.supermicro.com to download the BIOS image into a USB flash device and rename it "Super.ROM" for BIOS recovery use.

2. Insert the USB device that contains the new BIOS image ("Super.ROM") into your USB drive and power on the system
3. While powering on the system, please keep pressing <Ctrl> and <Home> simultaneously on your keyboard *until the following screen (or a screen similar to the one below) displays.*



Note: On the other hand, if the following screen displays, please load the "Super.ROM" file to the root folder and connect this folder to the system. (You can do so by inserting a USB device that contains the new "Super.ROM" image to your machine for BIOS recovery.)

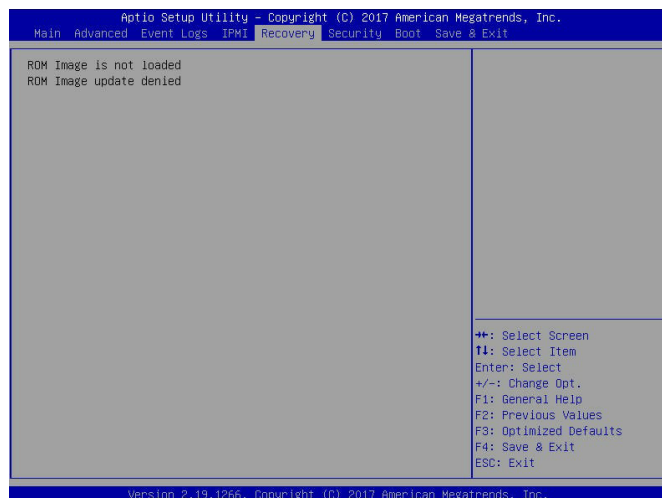

Warning: Please **stop** pressing the <Ctrl> and <Home> keys immediately when you see the

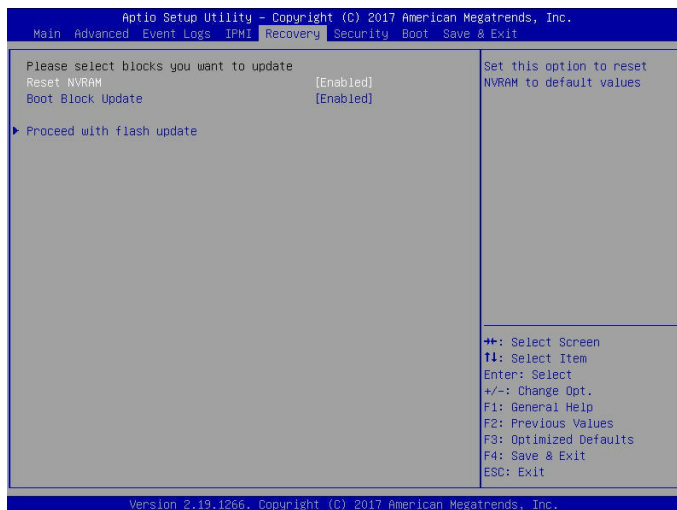

screen (or a similar screen) below; otherwise, it will trigger a system reboot.

4. After locating the new BIOS binary image, the system will enter the BIOS Recovery menu as shown below.

Note: At this point, you may decide if you want to start the BIOS recovery. If you decide to proceed with BIOS recovery, follow the procedures below.

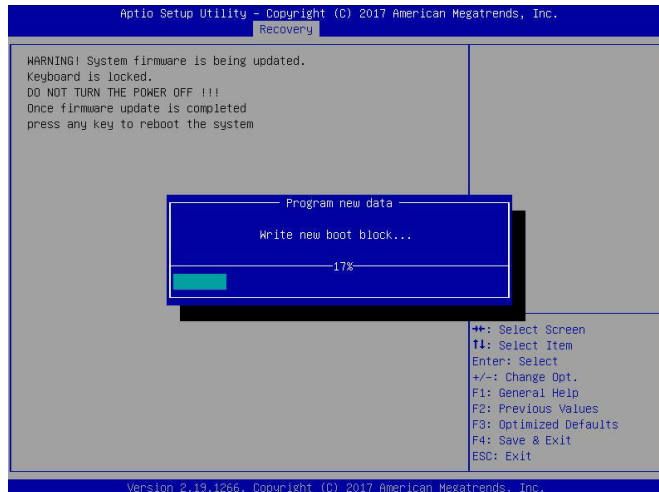

5. When the screen as shown above displays, use the arrow keys to select the item

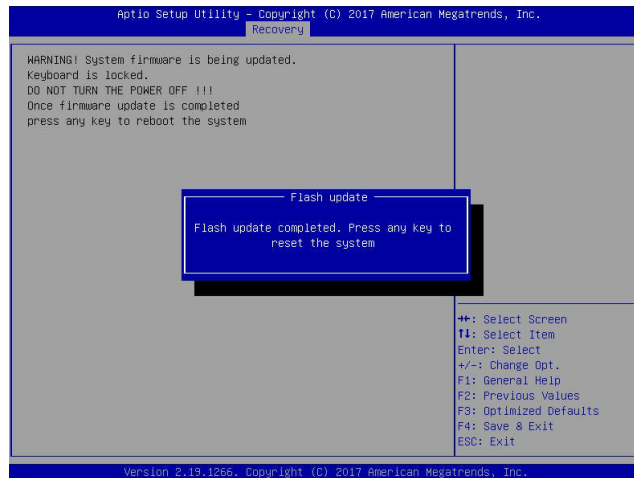

"Proceed with flash update" and press the <Enter> key. You will see the BIOS recovery progress as shown in the screen below.

Note: *Do not interrupt the BIOS flashing process until it has completed.*

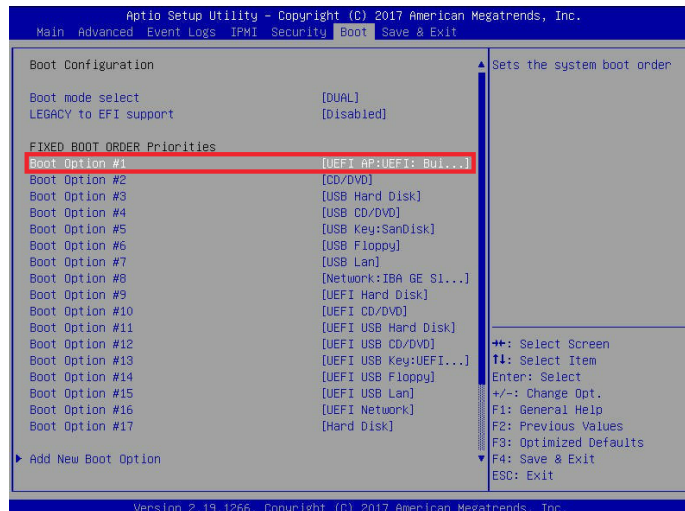

6. After the BIOS recovery process is completed, press any key to reboot the system.

7. Using a different system, extract the BIOS package into a USB flash drive.

```

UEFI Interactive Shell v2.1
EDK II
UEFI v2.50 (American Megatrends, 0x0005000C)
Mapping table
FS0: Alias(s):HD0r0b::BLK1:
PciRoot(0x0)/Pci(0x14,0x0)/USB(0x11,0x0)/HD(1,MBR,0x37501D72,0x800,0x1
C89592)
BLK0: Alias(s):
PciRoot(0x0)/Pci(0x14,0x0)/USB(0x11,0x0)
Press ESC in 1 seconds to skip startup.nsh or any other key to continue.
Shell: fs0:
FS0:\> cd #FUD0S
FS0:\#FUD0S\> cd SWJPMEE_09162017
FS0:\#FUD0S\SWJPMEE_09162017\> flash.nsh X11DPUT.314_

```

8. Press continuously during system boot to enter the BIOS setup utility. From the

```

Done.
[ Access Cmos Port Ex ]
<Read>
Index 0x51: 0x18
Done.
*****
* Program BIOS and ME (including FDT) regions...
*
*****
|          AMI Firmware Update Utility v5.09.01.1317          |
| Copyright (C)2017 American Megatrends Inc. All Rights Reserved. |
*****
CPUID = 50652
Reading flash ..... done
- ME data Size checking . ok
- FFS checksums ..... ok
- Check RomLayout ..... ok.
Erasing Boot Block ..... done
Updating Boot Block ..... done
Verifying Boot Block ..... done
Erasing Main Block ..... 0x00132000 (0%)

```

top of the tool bar, click on Boot and press <Enter> to enter the submenu. From the submenu list, select Boot Option #1 as shown below. Then, boot Option #1 to [UEFI

```

Verifying MCB Block ..... done
- Update success for FDR
- Update success for TE. -
- Successful Update Recovery Loader to OPRx!!
- Successful Update MFSB!!
- Successful Update FPR!!
- Successful Update MFS, IVB1 and IVB2!!
- Successful Update FLOG and UTK!!
- ME EntLine Image update success !!
WARNING : System must power-off to have the changes take effect!
Moving F80:\AFUDOS\SNJFME2_03162017\Fufef1x64.efi -> F80:\AFUDOS\SNJFME2_03162017\F
dt.smc
- [ok]
Moving F80:\AFUDOS\SNJFME2_03162017\Fufef1x64.efi -> F80:\AFUDOS\SNJFME2_0316201
7\Fufef1.smc
- [ok]
*****
* Please ignore this 'Shell: Cannot read from file - Device Error'
* warning message due to it does not impact flashing process.
*
*****
Deleting 'F80:\rom'
Delete successful.
F80:\>

```

AP:UEFI: Built-in EFI Shell]. Press <F4> to save the settings and exit the BIOS setup utility.

9. When the UEFI Shell prompt appears, type fs# to change the device directory path. Go to the directory that contains the BIOS package you extracted earlier from Step 7. Enter flash.nsh BIOSname.### at the prompt to start the BIOS update process.

Note: *Do not interrupt this process* until the BIOS flashing is complete.

10. The screen above indicates that the BIOS update process is completed. When you see the screen above, unplug the AC power cable from the power supply, clear CMOS, and plug the AC power cable in the power supply again to power on the system.
11. Press continuously to enter the BIOS setup utility.
12. Press <F3> to load the default settings.
13. After loading the default settings, press <F4> to save the settings and exit the BIOS setup utility.