



SuperServer<sup>®</sup>  
SYS-110A-16C-RN10SP  
SYS-110A-24C-RN10SP



USER'S MANUAL

Revision 1.0b

The information in this User's Manual has been carefully reviewed and is believed to be accurate. The vendor assumes no responsibility for any inaccuracies that may be contained in this document, and makes no commitment to update or to keep current the information in this manual, or to notify any person or organization of the updates. Please Note: For the most up-to-date version of this manual, please see our website at [www.supermicro.com](http://www.supermicro.com).

Super Micro Computer, Inc. ("Supermicro") reserves the right to make changes to the product described in this manual at any time and without notice. This product, including software and documentation, is the property of Supermicro and/or its licensors, and is supplied only under a license. Any use or reproduction of this product is not allowed, except as expressly permitted by the terms of said license.

IN NO EVENT WILL Super Micro Computer, Inc. BE LIABLE FOR DIRECT, INDIRECT, SPECIAL, INCIDENTAL, SPECULATIVE OR CONSEQUENTIAL DAMAGES ARISING FROM THE USE OR INABILITY TO USE THIS PRODUCT OR DOCUMENTATION, EVEN IF ADVISED OF THE POSSIBILITY OF SUCH DAMAGES. IN PARTICULAR, SUPER MICRO COMPUTER, INC. SHALL NOT HAVE LIABILITY FOR ANY HARDWARE, SOFTWARE, OR DATA STORED OR USED WITH THE PRODUCT, INCLUDING THE COSTS OF REPAIRING, REPLACING, INTEGRATING, INSTALLING OR RECOVERING SUCH HARDWARE, SOFTWARE, OR DATA.

Any disputes arising between manufacturer and customer shall be governed by the laws of Santa Clara County in the State of California, USA. The State of California, County of Santa Clara shall be the exclusive venue for the resolution of any such disputes. Supermicro's total liability for all claims will not exceed the price paid for the hardware product.

FCC Statement: This equipment has been tested and found to comply with the limits for a Class A or Class B digital device pursuant to Part 15 of the FCC Rules. These limits are designed to provide reasonable protection against harmful interference when the equipment is operated in industrial environment for Class A device or in residential environment for Class B device. This equipment generates, uses, and can radiate radio frequency energy and, if not installed and used in accordance with the manufacturer's instruction manual, may cause harmful interference with radio communications. Operation of this equipment in a residential area is likely to cause harmful interference, in which case you will be required to correct the interference at your own expense.

California Best Management Practices Regulations for Perchlorate Materials: This Perchlorate warning applies only to products containing CR (Manganese Dioxide) Lithium coin cells. "Perchlorate Material-special handling may apply. See [www.dtsc.ca.gov/hazardouswaste/perchlorate](http://www.dtsc.ca.gov/hazardouswaste/perchlorate)".



WARNING: This product can expose you to chemicals including lead, known to the State of California to cause cancer and birth defects or other reproductive harm. For more information, go to [www.P65Warnings.ca.gov](http://www.P65Warnings.ca.gov).

The products sold by Supermicro are not intended for and will not be used in life support systems, medical equipment, nuclear facilities or systems, aircraft, aircraft devices, aircraft/emergency communication devices or other critical systems whose failure to perform be reasonably expected to result in significant injury or loss of life or catastrophic property damage. Accordingly, Supermicro disclaims any and all liability, and should buyer use or sell such products for use in such ultra-hazardous applications, it does so entirely at its own risk. Furthermore, buyer agrees to fully indemnify, defend and hold Supermicro harmless for and against any and all claims, demands, actions, litigation, and proceedings of any kind arising out of or related to such ultra-hazardous use or sale.

Manual Revision 1.0b

Release Date: March 28, 2023

Unless you request and receive written permission from Super Micro Computer, Inc., you may not copy any part of this document. Information in this document is subject to change without notice. Other products and companies referred to herein are trademarks or registered trademarks of their respective companies or mark holders.

Copyright © 2023 by Super Micro Computer, Inc.  
All rights reserved.

**Printed in the United States of America**

# Preface

## About this Manual

This manual is written for professional system integrators and PC technicians. It provides information for the installation and use of the server. Installation and maintenance should be performed by experienced technicians only.

Please refer to the SYS-110A-16C/24C-RN10SP server specifications page on our website for updates on supported memory, processors and operating systems (<http://www.supermicro.com>).

## Notes

For your system to work properly, please follow the links below to download all necessary drivers/utilities and the user's manual for your server.

- Supermicro product manuals: <http://www.supermicro.com/support/manuals/>
- Product drivers and utilities: <https://www.supermicro.com/wdl>
- Product safety info: [http://www.supermicro.com/about/policies/safety\\_information.cfm](http://www.supermicro.com/about/policies/safety_information.cfm)

If you have any questions, please contact our support team at:  
[support@supermicro.com](mailto:support@supermicro.com)

This manual may be periodically updated without notice. Please check the Supermicro website for possible updates to the manual revision level.

## Secure Data Deletion

A secure data deletion tool designed to fully erase all data from storage devices can be found on our website: [https://www.supermicro.com/about/policies/disclaimer.cfm?url=/wdl/utility/Lot9\\_Secure\\_Data\\_Deletion\\_Utility/](https://www.supermicro.com/about/policies/disclaimer.cfm?url=/wdl/utility/Lot9_Secure_Data_Deletion_Utility/)

## Warnings

Special attention should be given to the following symbols used in this manual.



**Warning!** Indicates important information given to prevent equipment/property damage or personal injury.



**Warning!** Indicates high voltage may be encountered when performing a procedure.

# Contents

## **Chapter 1 Introduction**

1.1 Overview.....	8
1.2 System Features .....	9
Front View .....	9
Control Panel .....	10
Rear View.....	11
1.3 System Architecture .....	12
Main Components .....	12
1.4 Motherboard Layout .....	13
Quick Reference Table.....	14
Motherboard Block Diagram .....	16

## **Chapter 2 Server Installation**

2.1 Overview.....	17
2.2 Preparing for Setup.....	17
Choosing a Setup Location.....	17
Rack Precautions .....	17
Server Precautions.....	18
Rack Mounting Considerations .....	18
Ambient Operating Temperature.....	18
Airflow .....	18
Mechanical Loading.....	19
Circuit Overloading .....	19
Reliable Ground.....	19
2.3 Installing the Chassis into the Rack.....	20
Standard Rack .....	20
Installing the Chassis into a Standard Rack .....	20
Mid-Mount Telco Rack.....	21
Installing the Chassis into a Telco (Two-Post Style) Rack.....	21
Standard Rack with a Fixed Rail Kit.....	22
Installing the Chassis on Fixed Rails into a Standard Rack .....	22

## **Chapter 3 Maintenance and Component Installation**

3.1 Removing Power .....	25
3.2 Accessing the System.....	26

---

---

3.3 Static-Sensitive Devices.....	27
Precautions .....	27
3.4 Memory.....	28
DIMM Module Population Configuration .....	28
DIMM Installation .....	29
DIMM Removal .....	29
3.5 Motherboard Battery.....	30
M.2 Card Installation .....	31
3.6 Chassis Components .....	32
PCI Expansion Cards.....	32
Storage Drives .....	35
Installing 2.5" Hot-Swappable Hard Drives .....	35
System Cooling .....	37
System Fans.....	37
Checking the Server Air Flow.....	39
Overheating .....	39
Power Supply .....	40
<b>Chapter 4 Motherboard Connections</b>	
4.1 Power Connections .....	42
4.2 Headers and Connectors .....	44
4.3 Input/Output Ports .....	49
4.4 Jumpers.....	52
How Jumpers Work.....	52
4.5 LED Indicators.....	55
4.6 Front Control Panel.....	56
<b>Chapter 5 Software</b>	
5.1 Microsoft Windows OS Installation.....	58
5.2 Driver Installation.....	60
5.3 SuperDoctor® 5.....	61
5.4 BMC.....	62
BMC ADMIN User Password .....	62
<b>Chapter 6 Optional Components</b>	
6.1 Optional Parts List.....	63
<b>Chapter 7 Troubleshooting and Support</b>	
7.1 Information Resources .....	64

---

---



---

Website .....	64
Direct Links for the SYS-110A-16C/24C-RN10SP System .....	64
Direct Links for General Support and Information .....	64
7.2 Baseboard Management Controller (BMC).....	65
7.3 Troubleshooting Procedures .....	66
General Technique .....	66
No Power .....	66
No Video .....	67
System Boot Failure .....	67
Memory Errors .....	67
Losing the System Setup Configuration .....	67
When the System Becomes Unstable .....	67
7.4 Crash Dump Using BMC.....	69
7.5 UEFI BIOS Recovery .....	70
Overview .....	70
Recovering the UEFI BIOS Image.....	70
Recovering the Main BIOS Block with a USB Device.....	70
7.6 CMOS Clear .....	75
7.7 Where to Get Replacement Components .....	76
7.8 Reporting an Issue .....	76
Technical Support Procedures .....	76
Returning Merchandise for Service.....	76
Vendor Support Filing System .....	77
7.9 Feedback.....	77
<b>Appendix A Standardized Warning Statements for AC Systems</b>	
<b>Appendix B System Specifications</b>	
BSMI/RoHS .....	101

## Contacting Supermicro

### Headquarters

Address: Super Micro Computer, Inc.  
 980 Rock Ave.  
 San Jose, CA 95131 U.S.A.

Tel: +1 (408) 503-8000

Fax: +1 (408) 503-8008

Email: marketing@supermicro.com (General Information)  
 Sales-USA@supermicro.com (Sales Inquiries)  
 Government\_Sales-USA@supermicro.com (Gov. Sales Inquiries)  
 support@supermicro.com (Technical Support)  
 RMA@supermicro.com (RMA Support)  
 Webmaster@supermicro.com (Webmaster)

Website: [www.supermicro.com](http://www.supermicro.com)

### Europe

Address: Super Micro Computer B.V.  
 Het Sterrenbeeld 28, 5215 ML  
 's-Hertogenbosch, The Netherlands

Tel: +31 (0) 73-6400390

Fax: +31 (0) 73-6416525

Email: Sales\_Europe@supermicro.com (Sales Inquiries)  
 Support\_Europe@supermicro.com (Technical Support)  
 RMA\_Europe@supermicro.com (RMA Support)

Website: [www.supermicro.nl](http://www.supermicro.nl)

### Asia-Pacific

Address: Super Micro Computer, Inc.  
 3F, No. 150, Jian 1st Rd.  
 Zhonghe Dist., New Taipei City 235  
 Taiwan (R.O.C)

Tel: +886-(2) 8226-3990

Fax: +886-(2) 8226-3992

Email: Sales-Asia@supermicro.com.tw (Sales Inquiries)  
 Support@supermicro.com.tw (Technical Support)  
 RMA@supermicro.com.tw (RMA Support)

Website: [www.supermicro.com.tw](http://www.supermicro.com.tw)

# Chapter 1

## Introduction

### 1.1 Overview

This chapter provides a brief outline of the functions and features of the SuperServer SYS-110A-16C/24C-RN10SP. This system is based on the A3SSV-16C/24C-SPLN10F motherboard and the CSE-506TS-R301P chassis.

The following provides an overview of the specifications and capabilities.

System Overview	
<b>Motherboard</b>	A3SSV-16C-SPLN10F: SYS-110A-16C-RN10SP A3SSV-24C-SPLN10F: SYS-110A-24C-RN10SP
<b>Chassis</b>	CSE-506TS-R301P
<b>Processor Support</b>	Single Intel® Atom® P5000 series processor, with up to 24 cores at a 83W TDP
<b>Memory</b>	Supports up to 256GB of RDIMM or 64GB of Non-ECC/ECC UDIMM DDR4 memory in four slots SYS-110A-16C-RN10SP: DDR4 2667MT/s, SYS-110A-24C-RN10SP: DDR4 2933MT/s
<b>Drive Support</b>	Two 2.5" hot-swap SATA/SAS drive bays One M.2 M-Key 2242/2280/22110 (PCIe 2.0 x4/SATA 2.0/USB 2.0) One M.2 B-Key 2242/3042/2280 (PCIe 2.0 x2/SATA 2.0/USB 3.0) One M.2 E-Key 2230 (PCIe 2.0 x1/USB 2.0)
<b>Expansion Slots</b>	One PCIe 3.0 x8
<b>I/O Ports</b>	One VGA port Two rear USB 3.0 ports Eight RJ45 1GbE LAN ports Two 25G SFP28 LAN ports One RJ45 dedicated IPMI LAN port
<b>System Cooling</b>	Three internal fixed 40 x 28mm fans
<b>Power</b>	300W AC Redundant 80Plus Gold power supply
<b>Form Factor</b>	1U (W x H x D) 17.2 x 1.7 x 9.8in (437 x 43 x 249mm)

A Quick Reference Guide can be found on the product page of the Supermicro website. The following safety models associated with SYS-110A-16C/24C-RN10SP have been certified as compliant with UL or CSA: 506-3, 506-R3A3.

## 1.2 System Features

The following views of the system display the main features. Refer to [Appendix B](#) for additional specifications.

### Front View

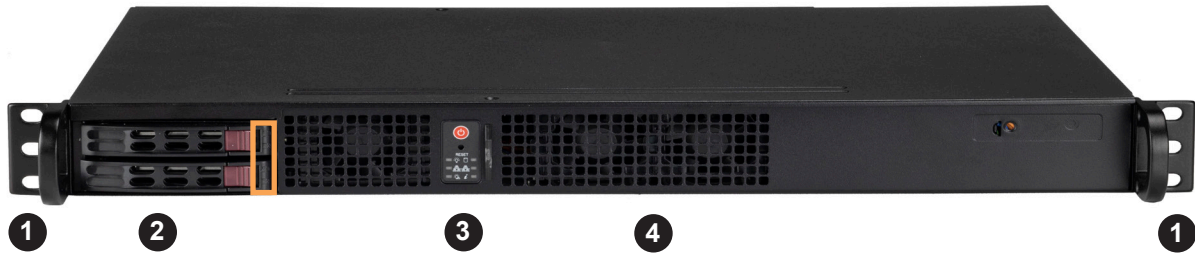

Figure 1-1. Front View

System Features: Front		
Item	Feature	Description
1	Rack Ear Brackets	Secures the server to the rack
2	Solid-State Drives	Two hot-swap 2.5" drives with LEDs (highlighted in orange, table below)
3	Control Panel	Front control panel with LEDs and buttons (see the following page) and unique BMC password label
4	Fans	Three internal fixed 40 x 28mm fans

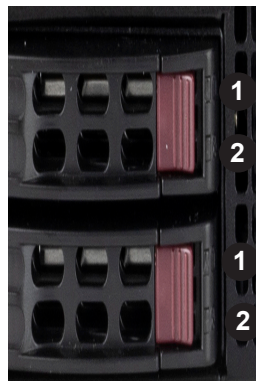

Figure 1-2. Solid-State Drive LEDs

Solid-State Drive LEDs		
Item	Feature	Description
1	SSD LED	Indicates drive activity when flashing
2	Fail/Locate LED	Indicates drive failure when solid, locates the drive when blinking

## Control Panel



Figure 1-3. Control Panel

Control Panel Features		
Item	Feature	Description
1	Power button	The main power switch applies or removes primary power from the power supply to the server but maintains standby power.
2	Reset Button	System Reset.
3	Power LED	Indicates power is being supplied to the system power supply units. This LED is illuminated when the system is operating normally.
4	HDD	Indicates activity on the storage drives when flashing.
5	NIC (LAN1) LED	Indicates network activity on LAN1 when flashing.
6	NIC (LAN2) LED	Indicates network activity on LAN2 when flashing.
7	Information LED	Alerts operator to several states, as noted in the table below.
8	Overheat LED	If this indicator is continuously on and red, an overheat condition has occurred.

Information LED	
Color, Status	Description
Red, solid	An overheat condition has occurred.
Red, blinking at 1Hz	Fan failure, check for an inoperative fan.
Red, blinking at 0.25Hz	Power failure, check for a non-operational power supply.
Red, solid, with Power LED blinking green	Fault detected
Blue and red, blinking at 10 Hz	Recovery mode
Blue, solid	UID has been activated locally to locate the server in a rack environment.
Blue, blinking at 1Hz	UID has been activated using the BMC to locate the server in a rack environment.
Blue, blinking at 2Hz	BMC is resetting
Blue, blinking at 4Hz	BMC is setting factory defaults
Blue, blinking at 10Hz with Power LED blinking green	BMC/BIOS firmware is updating

## Rear View



Figure 1-4. System: Rear View

System Features: Rear		
Item	Feature	Description
1	Power Supplies	300W AC redundant power supplies
2	I/O Rear Panel	Rear panel for I/O devices supported on the motherboard (see <a href="#">Chapter 4</a> )
3	PCIe Slot	One HHHL PCIe expansion slot
4	Security slot	Kensington® Security Lock

## 1.3 System Architecture

This section shows the locations of the system's main components.

### Main Components

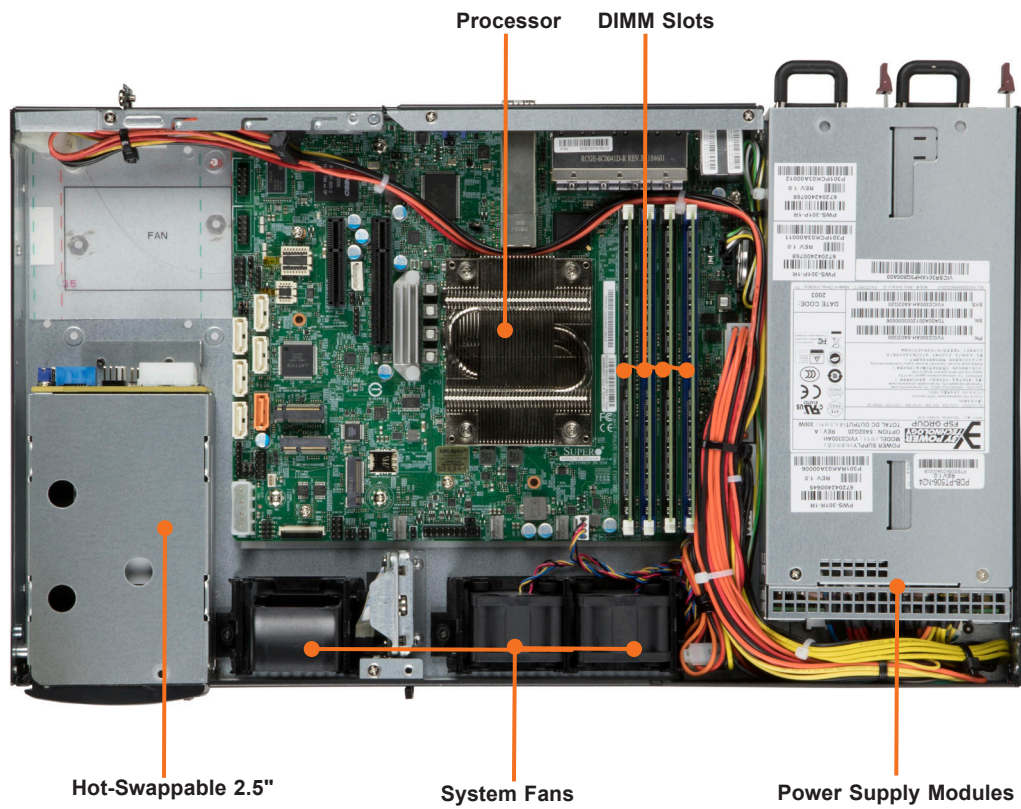

Figure 1-5. Main Component Locations

## 1.4 Motherboard Layout

Below is a layout of the A3SSV-16C/24C-SPLN10F motherboard with jumper, connector and LED locations shown. See the table on the following page for descriptions. For detailed descriptions, pinout information and jumper settings, refer to [Chapter 4](#) or the [Motherboard Manual](#).

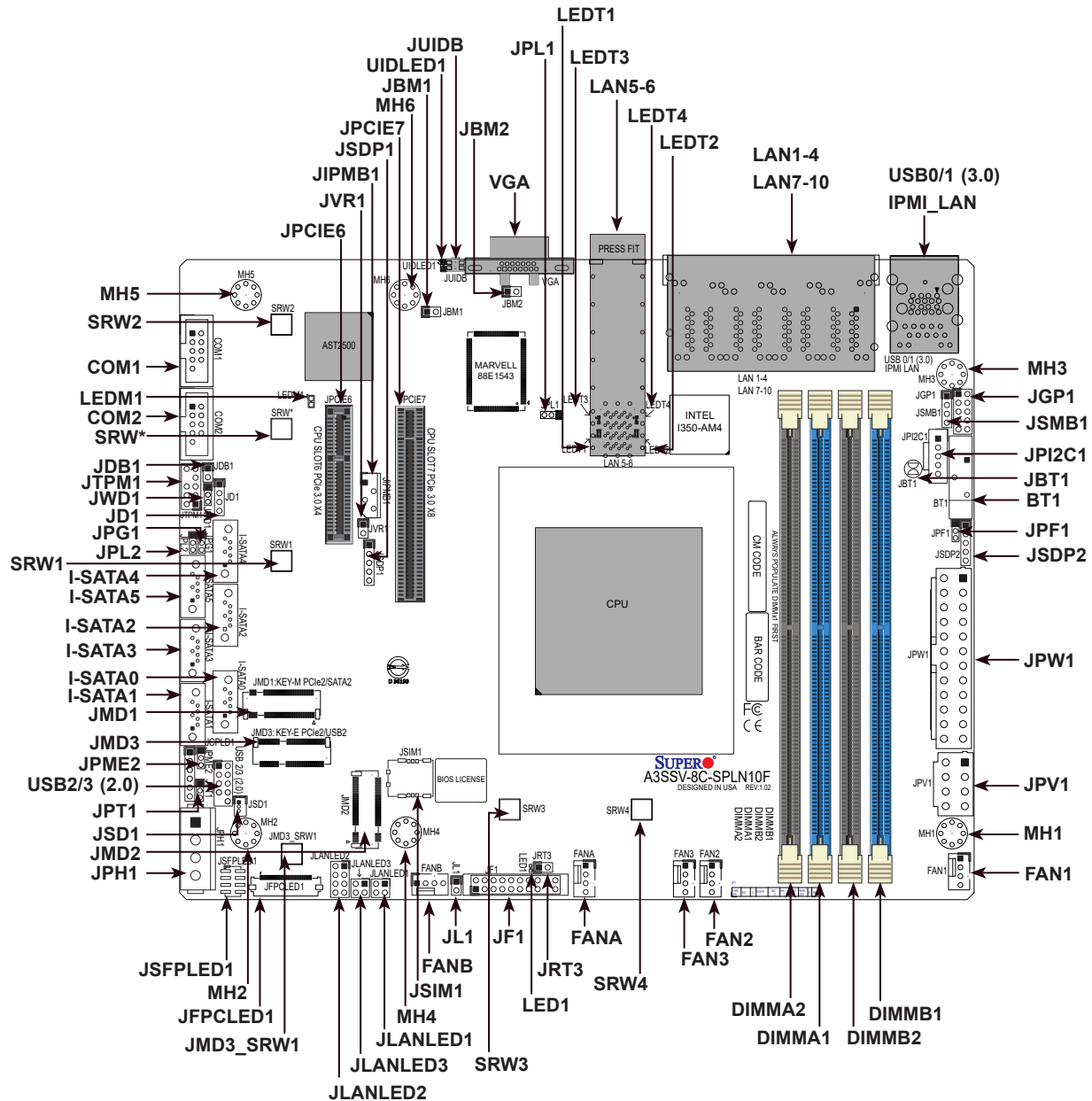

Figure 1-6. Motherboard Layout

## Quick Reference Table

Jumper	Description	Default Setting
JBM1	Disable IPMI Share LAN	Pins 1-2 Open: Enabled
JBM2	Disable IPMI Dedicated LAN	Pins 1-2 Open: Enabled
JBT1	CMOS Clear	Open: Normal
JPF1	Power Force On	Pins 1-2: ATX mode Pins 2-3: Force PS-ON mode (Default)
JPG1	Onboard VGA Enable/Disable	Pins 1-2: (Enabled)
JPL1	LAN1–LAN4 Enable/Disable	Pins 1-2: (Enabled)
JPME2	ME Manufacturing Mode	Pins 1-2: (Normal)
JWD1	Watch Dog Timer	Pins 1-2: (Reset by BMC)
LED	Description	Status
LED1	Power LED	Solid Green: Power On
LEDM1	BMC Heartbeat	Blinking Green: BMC Normal
UIDLED1	UID LED	Solid Blue: Unit Identified
Connector	Description	
BT1	Onboard Battery	
COM1, COM2	COM Headers	
FAN1 - FAN3, FANA, FANB	CPU/System Fan Headers (FAN1: CPU Fan)	
IPMI_LAN	IPMI LAN Port	
I-SATA0 - I-SATA5	Intel® SoC SATA 2.0 Ports (I-SATA0: SuperDOM)	
JD1	Speaker/Buzzer Header (Pins 1-4)	
JF1	Front Control Panel Header	
JFPCLED1	LED Board Cable Connector for FPB-FPE300-LED10 (Reserved for FPB-FPE300-LED10 on E300 chassis use)	
JGP1	General Purpose I/O Header	
JIPMB1	System Management Bus Header (for IPMI card)	
JL1	Chassis Intrusion Header	
JLANLED1	LAN3–LAN4 Port Activity LED Header	
JLANLED2	LAN5–LAN8 Port Activity LED Header	
JLANLED3	LAN9–LAN10 Port Activity LED Header	
JMD1	M.2 M-Key 2242/2280/22110 (supports PCIe 2.0 x4/SATA 2.0/USB 2.0) Slot	
JMD2	M.2 B-Key 2242/3042/2280 (supports PCIe 2.0 x2/SATA 2.0/USB 3.0) Slot	
JMD3	M.2 E-Key 2230 (supports PCIe 2.0 x1/USB 2.0) Slot	
JMD3_SRW1	JMD3 M.2 Holding Screw	
JPCIE6	CPU PCIe 3.0 x4 Slot	
JPCIE7	CPU PCIe 3.0 x8 Slot	

<b>Connector</b>	<b>Description</b>
JPH1	4-pin Power Connector (for one HDD system)
JP <sup>2</sup> C1	Power Supply SMBus I <sup>2</sup> C Header
JPV1	8-pin 12V DC Power Connector
JPW1	24-pin ATX Power Connector
JRT3	Thermal Diode 1
JSD1	SATA DOM Power Connector
JSDP1	Software-Defined Pins for LAN5–LAN6
JSDP2	Software-Defined Pins LAN1–LAN4
JSFPLED1	SFP LAN LED Board Cable Connector for FPB-FPE300-LED10
JSIM1	Nano SIM Card Slot
JSMB1	System Management Bus Header
JTPM1	Trusted Platform Module (TPM)/Port 80 Header
JUIDB	Unit Identifier Switch
JVR1	VRM I <sup>2</sup> C SMBus to CPU Header
LAN1–4, LAN7–10	Eight LAN 1G Base-T (Intel i350-AM4 & Marvell 88E1543) Ports
LAN5–6	Two LAN SFP28 25G Ports
MH1–MH6	Mounting Holes
SRW1–SRW4, SRW*	M.2 Holding Screws
USB0/1	Back Panel USB 3.0 Ports
USB2/3	Front Accessible USB 2.0 Header
VGA	VGA Port

## Motherboard Block Diagram

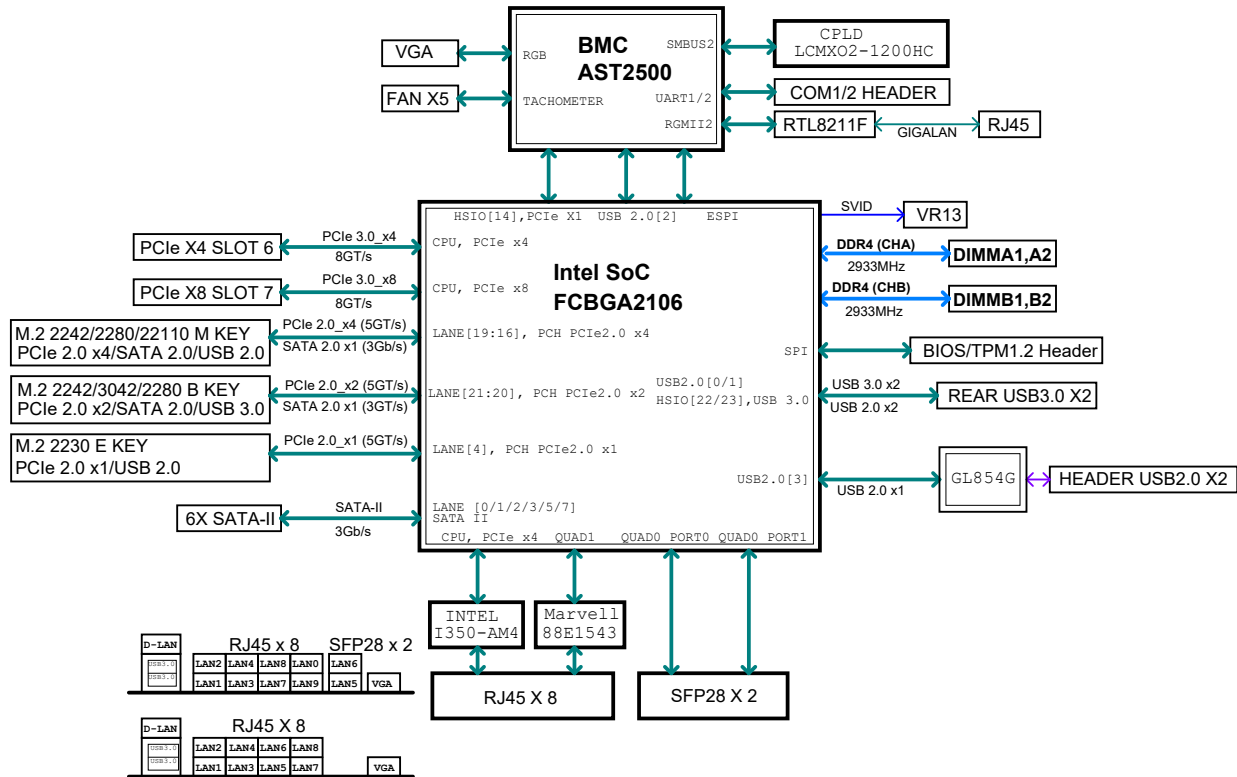

Figure 1-7. Motherboard Block Diagram

# Chapter 2

## Server Installation

### 2.1 Overview

This chapter provides advice and instructions for mounting your system in a server rack. If your system is not already fully integrated with system memory etc., refer to [Chapter 3](#) for details on installing those specific components.

**Caution:** Electrostatic Discharge (ESD) can damage electronic components. To prevent such damage to PCBs (printed circuit boards), it is important to use a grounded wrist strap, handle all PCBs by their edges, and keep them in anti-static bags when not in use.

### 2.2 Preparing for Setup

The box in which the system was shipped should include the rackmount hardware needed to install it into the rack. Please read this section in its entirety before you begin the installation.

#### Choosing a Setup Location

- The system should be situated in a clean, dust-free area that is well ventilated. Avoid areas where heat, electrical noise, and electromagnetic fields are generated.
- Leave enough clearance in front of the rack so that you can open the front door completely (~25 inches) and approximately 30 inches of clearance in the back of the rack to allow sufficient space for airflow and access when servicing.
- This product should be installed only in a Restricted Access Location (dedicated equipment rooms, service closets, etc.).
- This product is not suitable for use with visual display workplace devices according to §2 of the German Ordinance for Work with Visual Display Units.

#### Rack Precautions

- Ensure that the leveling jacks on the bottom of the rack are extended to the floor so that the full weight of the rack rests on them.
- In single rack installations, stabilizers should be attached to the rack. In multiple rack installations, the racks should be coupled together.

- Always make sure the rack is stable before extending a server or other component from the rack.
- You should extend only one server or component at a time - extending two or more simultaneously may cause the rack to become unstable.

## Server Precautions

- Review the electrical and general safety precautions in [Appendix A](#).
- Determine the placement of each component in the rack *before* you install the rails.
- Install the heaviest server components at the bottom of the rack first and then work your way up.
- Use a regulating uninterruptible power supply (UPS) to protect the server from power surges and voltage spikes and to keep your system operating in case of a power failure.
- Allow any drives and power supply modules to cool before touching them.
- When not servicing, always keep the front door of the rack and all covers/panels on the servers closed to maintain proper cooling.

## Rack Mounting Considerations

### *Ambient Operating Temperature*

If installed in a closed or multi-unit rack assembly, the ambient operating temperature of the rack environment may be greater than the room's ambient temperature. Therefore, consideration should be given to installing the equipment in an environment compatible with the manufacturer's maximum rated ambient temperature ( $T_{mra}$ ).

### *Airflow*

Equipment should be mounted into a rack so that the amount of airflow required for safe operation is not compromised.

### ***Mechanical Loading***

Equipment should be mounted into a rack so that a hazardous condition does not arise due to uneven mechanical loading.

### ***Circuit Overloading***

Consideration should be given to the connection of the equipment to the power supply circuitry and the effect that any possible overloading of circuits might have on overcurrent protection and power supply wiring. Appropriate consideration of equipment nameplate ratings should be used when addressing this concern.

### ***Reliable Ground***

A reliable ground must be maintained at all times. To ensure this, the rack itself should be grounded. Particular attention should be given to power supply connections other than the direct connections to the branch circuit (i.e. the use of power strips, etc.).



To prevent bodily injury when mounting or servicing this unit in a rack, you must take special precautions to ensure that the system remains stable. The following guidelines are provided to ensure your safety:

- This unit should be mounted at the bottom of the rack if it is the only unit in the rack.
- When mounting this unit in a partially filled rack, load the rack from the bottom to the top with the heaviest component at the bottom of the rack.
- If the rack is provided with stabilizing devices, install the stabilizers before mounting or servicing the unit in the rack.
- Slide rail mounted equipment is not to be used as a shelf or a work space.



**Warning:** Stability hazard. The rack stabilizing mechanism must be in place, or the rack must be bolted to the floor before you slide the unit out for servicing. Failure to stabilize the rack can cause the rack to tip over.



**Warning:** Slide rail mounted equipment is not to be used as a shelf or a work space.

## 2.3 Installing the Chassis into the Rack

This section provides information on installing the CSE-506TS-R301P chassis into a rack unit. Due to the variety of rack units on the market, the assembly procedure might differ slightly. Also refer to the installation instructions that came with the rack unit you are using.

### Standard Rack

#### *Installing the Chassis into a Standard Rack*

1. Gather the four mounting screws shipped with the system.
2. Align the mounting holes of the chassis with the thru-holes of the rack.
3. Insert the mounting screws into the thru-holes in the front of the chassis and tighten the screws until the chassis is secured to the rack.

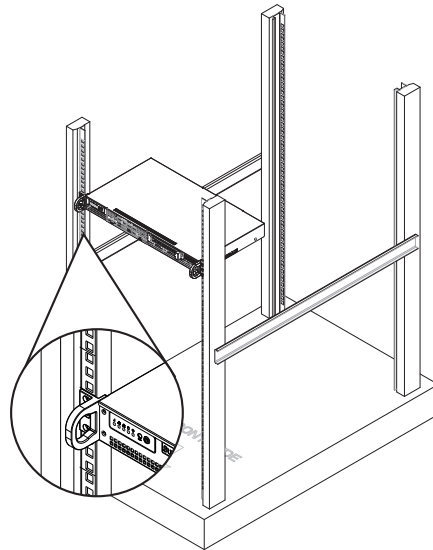

**Figure 2-1. Installing the Server into a Rack**

**Note:** Figures are for illustrative purposes only. Always install servers to the bottom of a rack first.



**Warning:** Do not pick up the server by the front handles. They are designed to pull the system from a rack only.



**Stability hazard.** The rack stabilizing mechanism must be in place, or the rack must be bolted to the floor before you slide the unit out for servicing. Failure to stabilize the rack can cause the rack to tip over.

## Mid-Mount Telco Rack

The CSE-506TS-R301P supports Telco Rack installation. The compact design allows it to be installed into a Telco rack without the use of rails.

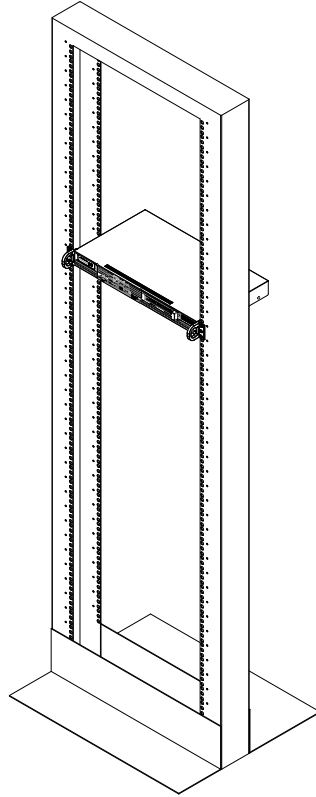

**Figure 2-2. Installing the Server into a Rack**

**Note:** Figures are for illustrative purposes only. Servers should always be installed in racks from the bottom up.

### *Installing the Chassis into a Telco (Two-Post Style) Rack*

To install the chassis into a Telco style two-post rack, use two L-shaped brackets on either side of the chassis (four total).

1. Determine how far the server will extend out the front of the rack. Larger chassis should be positioned to balance the weight between front and back.
2. If a bezel is included on your chassis, remove it.
3. Attach the two front brackets to each side of the chassis.
4. Attach the two rear brackets positioned with just enough space to accommodate the width of the Telco rack.
5. Slide the chassis into the rack and tighten the brackets to the rack.

### Standard Rack with a Fixed Rail Kit

The chassis can be mounted in a rack using a fixed rail kit (optional, MCP-290-50404-0N).

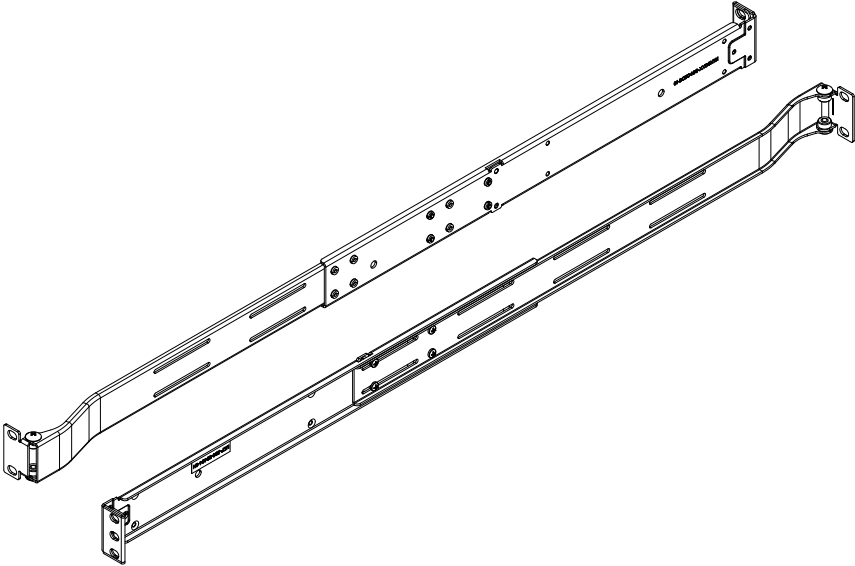

Figure 2-3. Fixed Rails

### Installing the Chassis on Fixed Rails into a Standard Rack

1. Power down the server and disconnect the power cord from the power strip or outlet, then from the power supply inlet.
2. Unscrew and remove the right and left ear brackets from the front of the chassis.
3. Adjust the rails to the appropriate length according to the distance between the front and back of the rack they will be installed on. Use eight screws through the rail openings to secure the rail length adjustments, as pictured below.

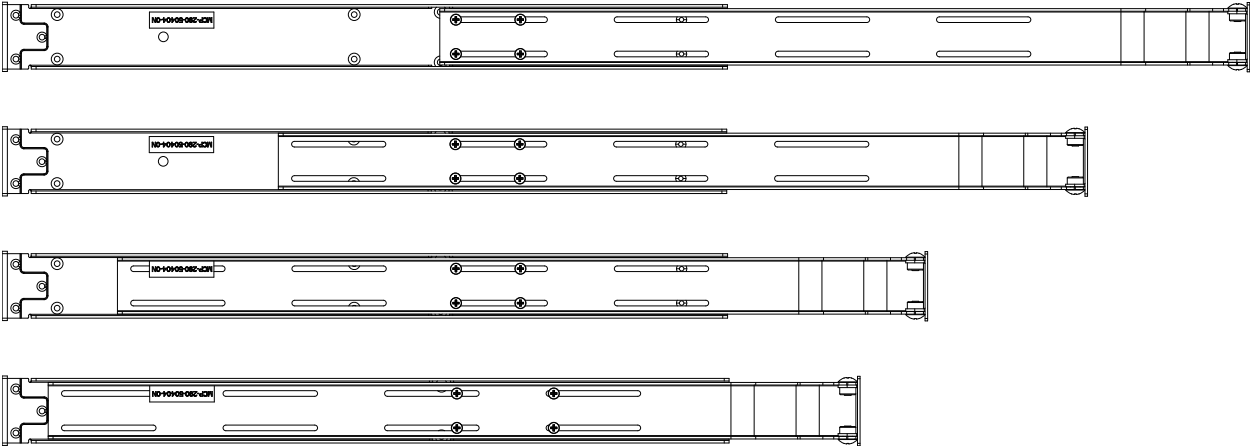

Figure 2-4. Rail Length Adjustments

1. Attach the rails to the chassis using three screws through the holes in each front bracket to secure a bracket to each side of the chassis.

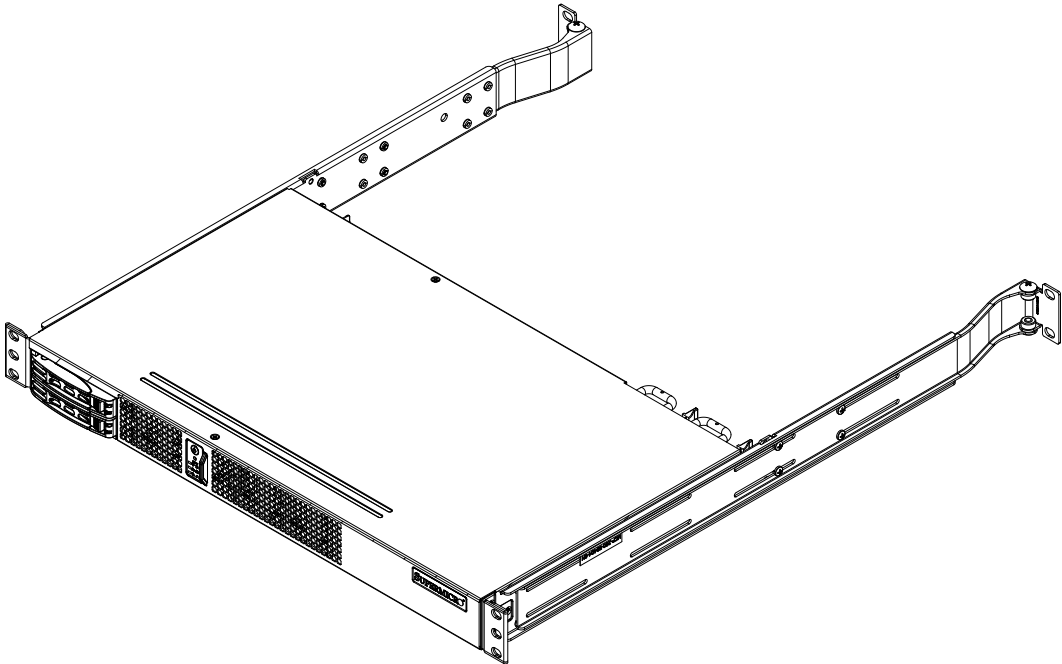

Figure 2-5. Rails Attached to the Chassis

2. Install the chassis on rails into the rack, using three screws through each front bracket and two screws through each rear bracket to secure the rails to the rack.

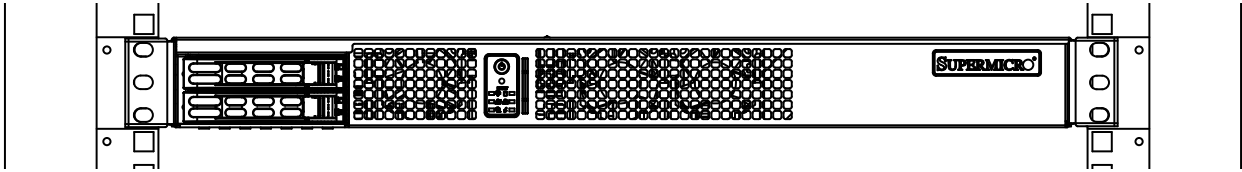

Figure 2-6. Front of Chassis on Rails Installed into a Rack

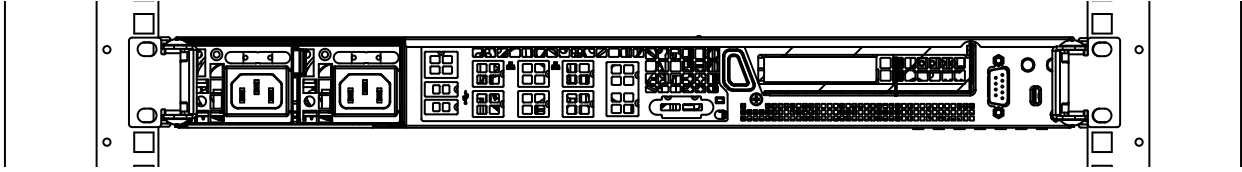
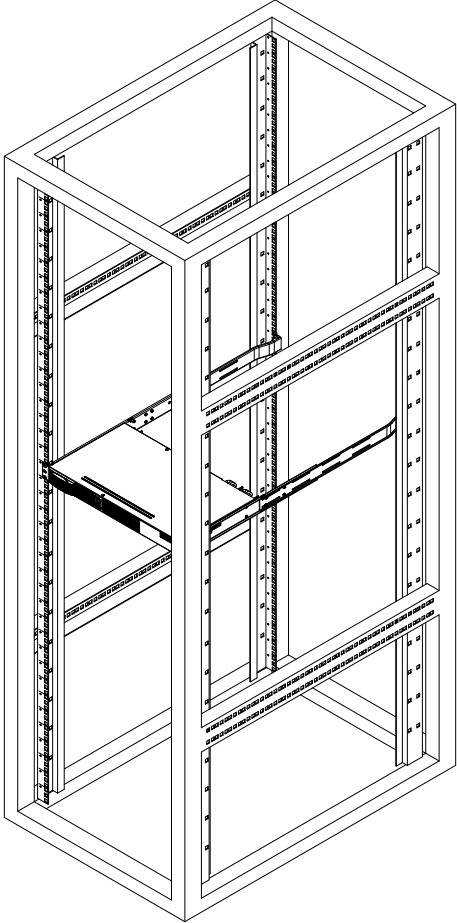

Figure 2-7. Rear of Chassis on Rails Installed into a Rack



**Figure 2-8. Installing the Server on Fixed Rails into a Rack**

**Note:** Figures are for illustrative purposes only. Servers should always be installed in racks from the bottom up.

## Chapter 3

# Maintenance and Component Installation

This chapter provides instructions on installing and replacing main system components. To prevent compatibility issues, only use components that match the specifications and/or part numbers given.

Installation or replacement of most components require that power first be removed from the system. Please follow the procedures given in each section.

### 3.1 Removing Power

Use the following procedure to ensure that power has been removed from the system. This step is necessary when removing or installing non-hot-swap components or when replacing a non-redundant power supply.

1. Use the operating system to power down the system.
2. After the system has completely shut-down, disconnect the AC power cords from the power strip or outlet.
3. Disconnect the power cords from the power supply modules.

## 3.2 Accessing the System

### *Removing the Chassis Cover*

1. Power down the system as described in Section 3.1.
2. Remove two screws from the chassis top and two screws from each chassis side.
3. Lift the cover up and off the chassis.



**Caution:** Do not operate the server without the cover in place. The chassis cover must be in place to allow proper airflow and prevent overheating.

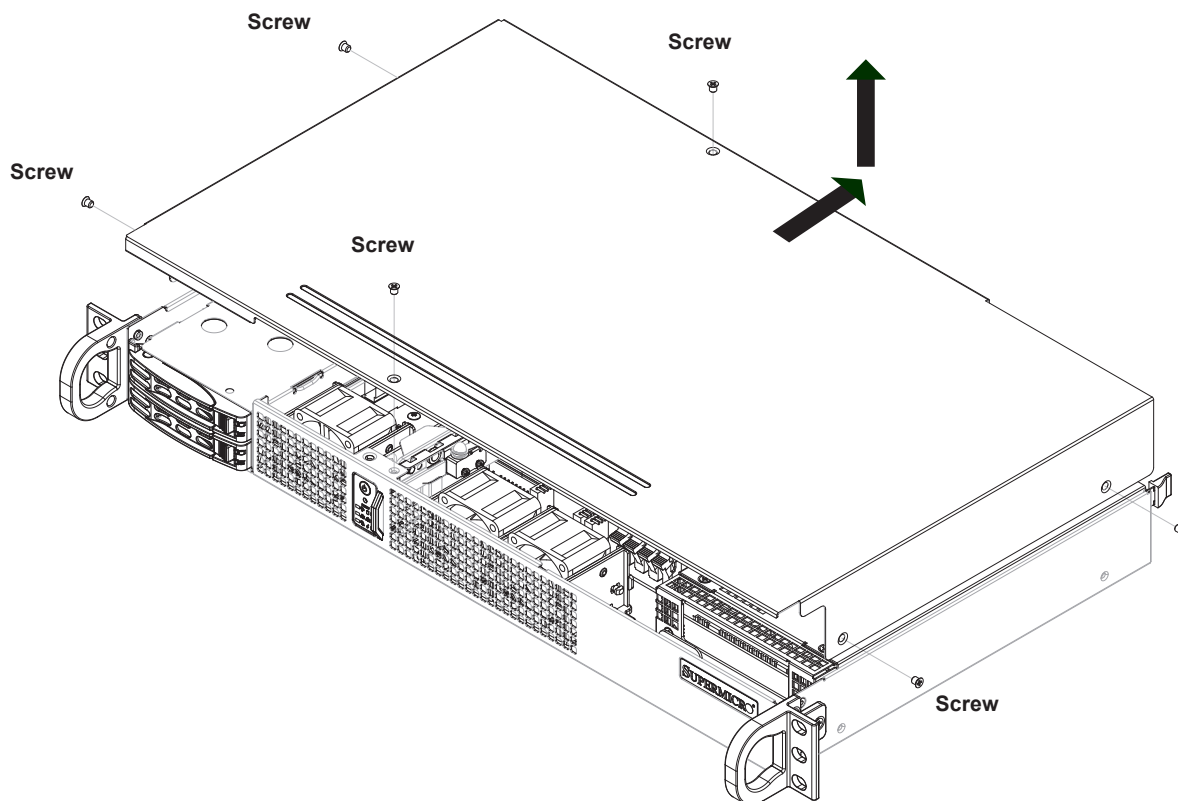

Figure 3-1. Removing the Chassis Cover

### 3.3 Static-Sensitive Devices

Electrostatic Discharge (ESD) can damage electronic components.

To avoid damaging your motherboard, it is important to handle it very carefully. The following measures are generally sufficient to protect the system PCBs from ESD.

#### Precautions

- Use a grounded wrist strap designed to prevent static discharge.
- Touch a grounded metal object before removing any PCB (printed circuit board) from its antistatic bag.
- Handle PCBs by their edges only; do not touch its components, peripheral chips, memory modules, or gold contacts.
- When handling chips or modules, avoid touching their pins.
- Put the PCBs back into their antistatic bags when not in use.
- Use only the correct type of onboard CMOS battery. Do not install the onboard battery upside down to avoid a possible explosion.

## 3.4 Memory

The A3SSV-16C/24C-SPLN10F motherboard supports up to 256GB of ECC RDIMM or 64GB of Non-EC/ECC UDIMM DDR4 memory in four memory slots. Refer to the tables below for the recommended DIMM population order and additional memory information.

### DIMM Module Population Configuration

For optimal memory performance, follow the table below when populating memory.

Memory Population (Balanced)				
DIMMA1	DIMMB1	DIMMA2	DIMMB2	Total System Memory
4GB	4GB			8GB
4GB	4GB	4GB	4GB	16GB
8GB	8GB			16GB
8GB	8GB	8GB	8GB	32GB
16GB	16GB			32GB
16GB	16GB	16GB	16GB	64GB
32GB	32GB			64GB
32GB	32GB	32GB	32GB	128GB
64GB	64GB			128GB
64GB	64GB	64GB	64GB	256GB

## DIMM Installation

1. Insert the desired number of DIMMs into the memory slots, starting with DIMMA1, DIMMB1, DIMMA2, DIMMB2. For best performance, please use the memory modules of the same type and speed.
2. Push the release tabs outwards on both ends of the DIMM slot to unlock it.
3. Align the key of the DIMM module with the receptive point on the memory slot.
4. Align the notches on both ends of the module against the receptive points on the ends of the slot.
5. Press both ends of the module straight down into the slot until the module snaps into place.
6. Press the release tabs to the lock positions to secure the DIMM module into the slot.

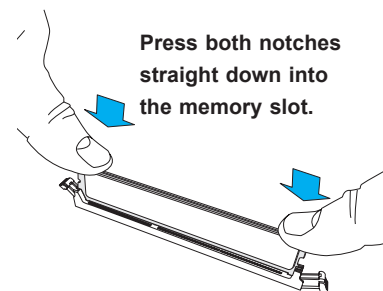
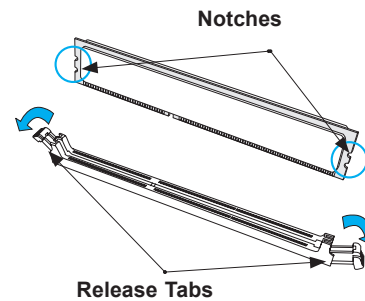
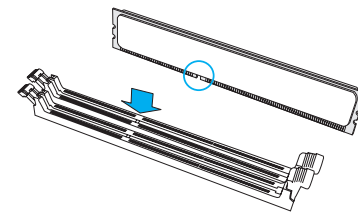
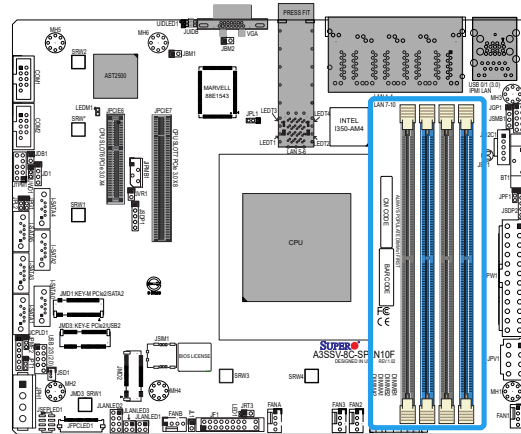

## DIMM Removal

Press both release tabs on the ends of the DIMM module to unlock it. Once the DIMM module is loosened, remove it from the memory slot.

## 3.5 Motherboard Battery

The motherboard uses non-volatile memory to retain system information when system power is removed. This memory is powered by a lithium battery residing on the motherboard.

### *Replacing the Battery*

Begin by the removing the top cover from the system.

1. Remove any components obstructing the battery.
2. Push aside the small clamp that covers the edge of the battery. When the battery is released, lift it out of the holder.
3. To insert a new battery, slide one edge under the lip of the holder with the positive (+) side facing up. Then push the other side down until the clamp snaps over it.

**Note:** Handle used batteries carefully. Do not damage the battery in any way; a damaged battery may release hazardous materials into the environment. Do not discard a used battery in the garbage or a public landfill. Please comply with the regulations set up by your local hazardous waste management agency to dispose of your used battery properly.

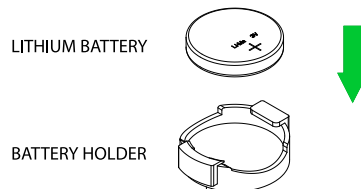

**Figure 3-2. Installing the Onboard Battery**

**Warning:** There is a danger of explosion if the onboard battery is installed upside down (which reverses its polarities). This battery must be replaced only with the same or an equivalent type recommended by the manufacturer (CR2032).

## **M.2 Card Installation**

The A3SSV-16C/24C-SPLN10F supports three M.2 connectors. One M.2 M-Key PCIe 2.0 x4/SATA 2.0/USB 2.0, 2242/2280/22110 connector, one M.2 B-Key PCIe 2.0 x2/SATA 2.0/USB 3.0, 2242/3042/2280 connector, and one M.2 E-Key PCIe 2.0 x1/USB 2.0, 2230 connector. To install an M.2 card, first locate the connector and the standoff on the motherboard.

### ***Installing M.2 Cards***

1. Remove the screw from the standoff and set aside.
2. Remove the old M.2 card.
3. Insert a new M.2 card into the slot.
4. Align the cutoff circle with the standoff.
5. Reinstall the screw on the standoff.

## 3.6 Chassis Components

This section provides instructions on installing and replacing system components. To assure compatibility, only use components that match the specifications or part numbers given.

### PCI Expansion Cards

The system supports a riser card that allows a half-length expansion card to fit inside the chassis. Install a PCIe 3.0 x8 card using the RSC-RR1U-E8.



Figure 3-3. Expansion Slot Location

**Assemble the PCIe Expansion Card, Riser Card, and Brackets**

1. Remove power as described in Section 3.1 and remove the chassis cover.
2. Remove the PCIe I/O shield.
3. Remove the PCIe slot bracket.
4. Outside of the chassis, install the riser card to the riser card bracket.
5. Align the expansion card through the PCIe bracket.
6. Insert the expansion card into the riser card.
7. Align the PCIe bracket with the riser card bracket.
8. Secure the PCIe bracket and the riser card bracket together.

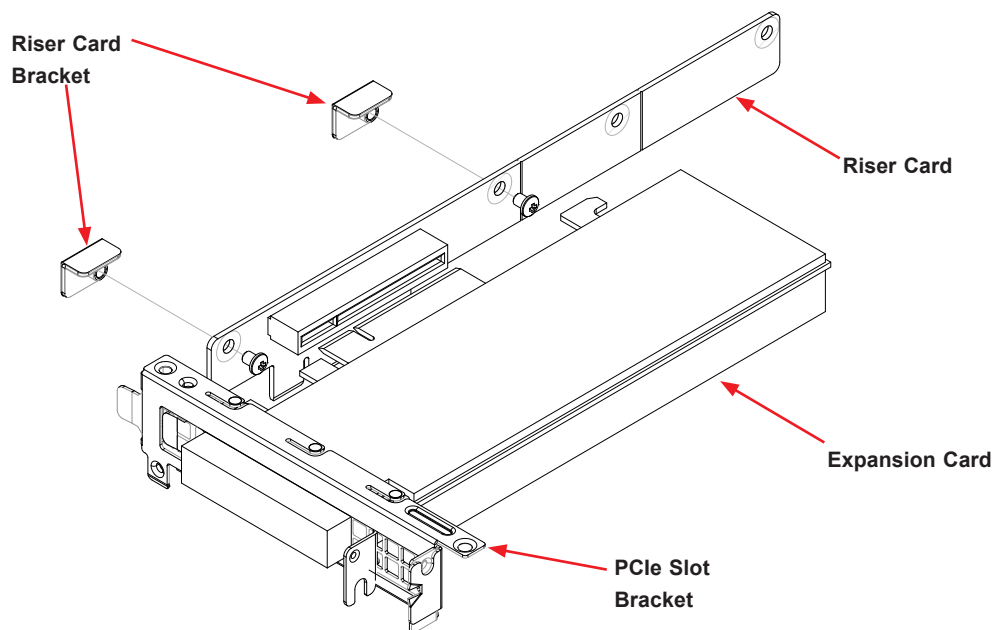

**Figure 3-4. Assembling the PCIe Expansion Card, Riser Card and Brackets**

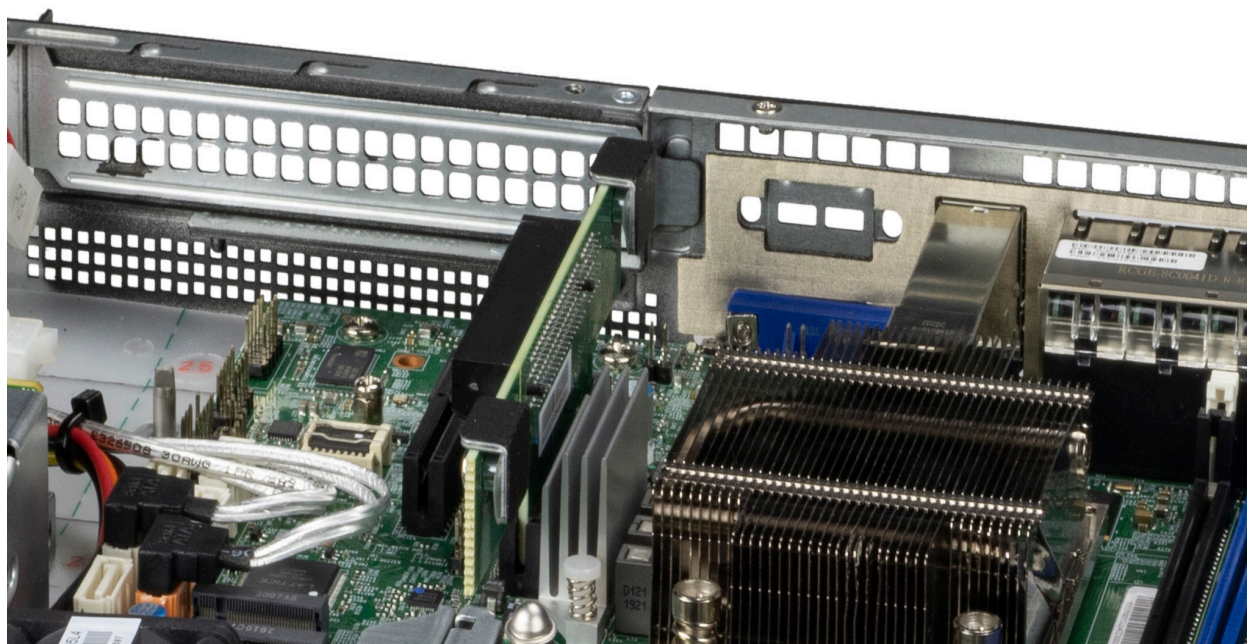

**Figure 3-5. Installing the Expansion Card Assembly**

***Installing the Expansion Card Assembly***

1. Insert the assembly into the motherboard and align with the chassis rear.
2. Secure the assembly to the chassis with screws.

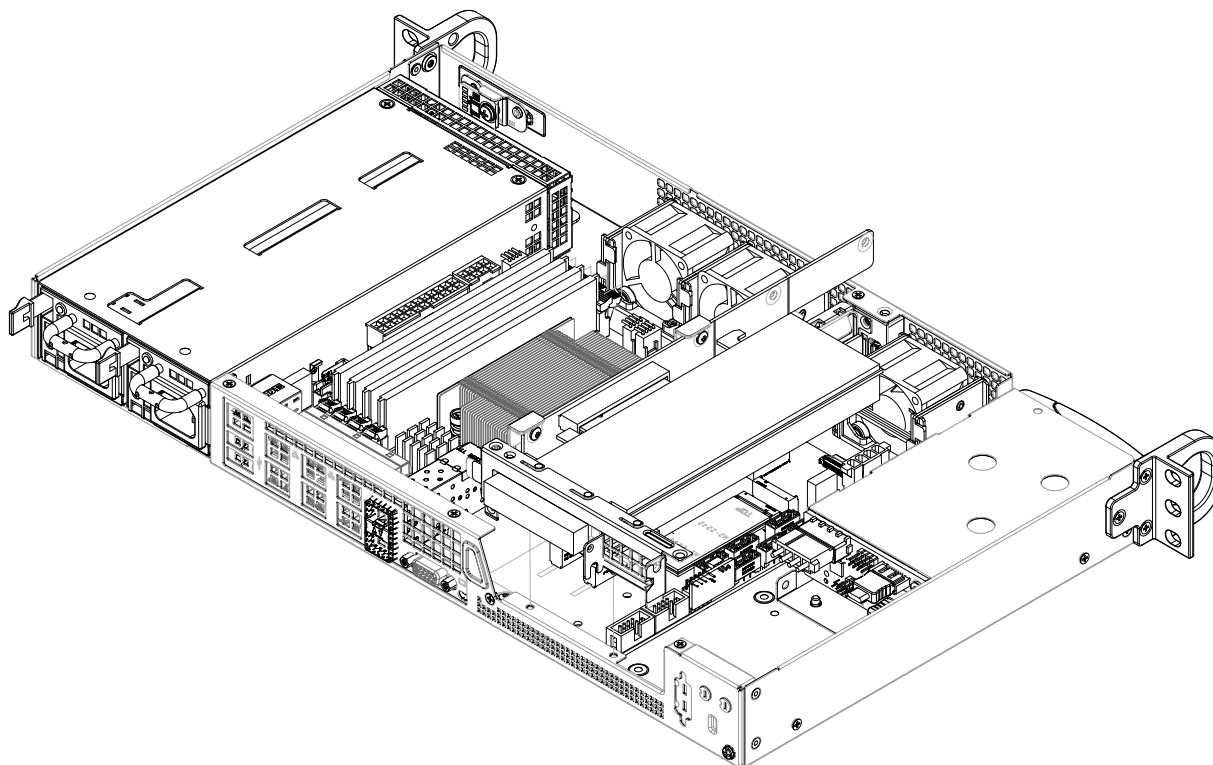

**Figure 3-6. Installing the Expansion Card Assembly**

## Storage Drives

The chassis supports two 2.5" hot-swappable hard disk drives. Only enterprise-level hard drives are recommended. **Note:** The hard drives in your chassis may look slightly different from the ones shown in this manual.

### *Installing 2.5" Hot-Swappable Hard Drives*

1. Press the release tab and use the lever to pull the drive tray out of the chassis.

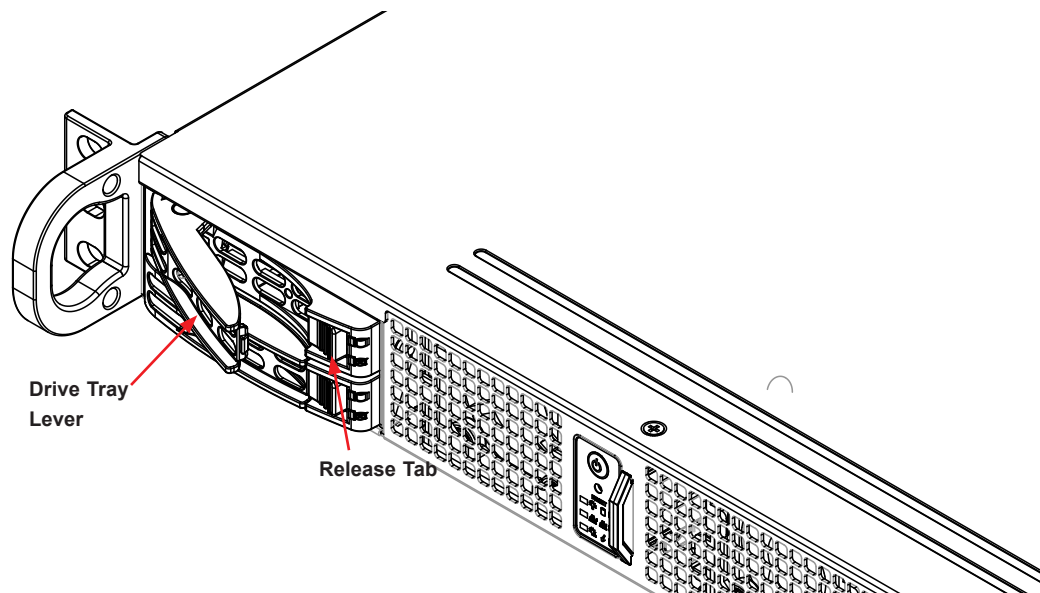

Figure 3-7. Unlocking the Drive Tray Lever

2. Remove the four screws and lift the dummy hard drive insert from the drive tray

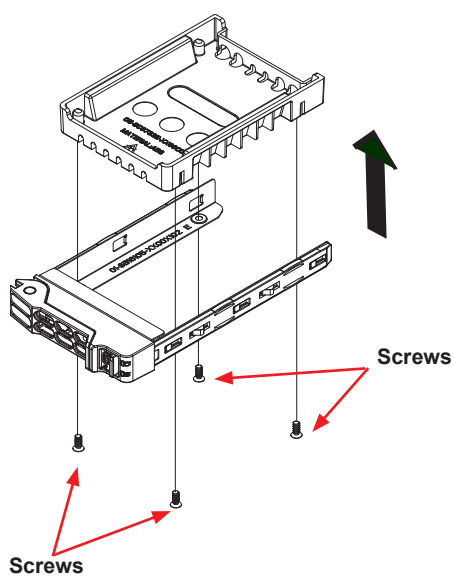

Figure 3-8. Removing Dummy Drive

1. Install the drive into the drive tray and secure it with screws.

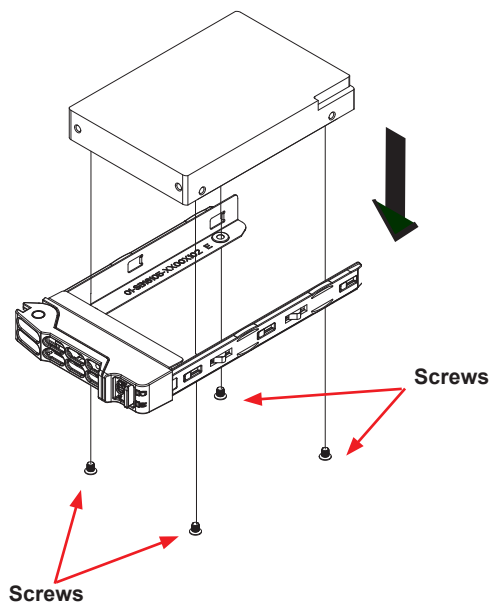

Figure 3-9. Installing Storage Drives

2. Insert the drive into the chassis and lock the drive tray.

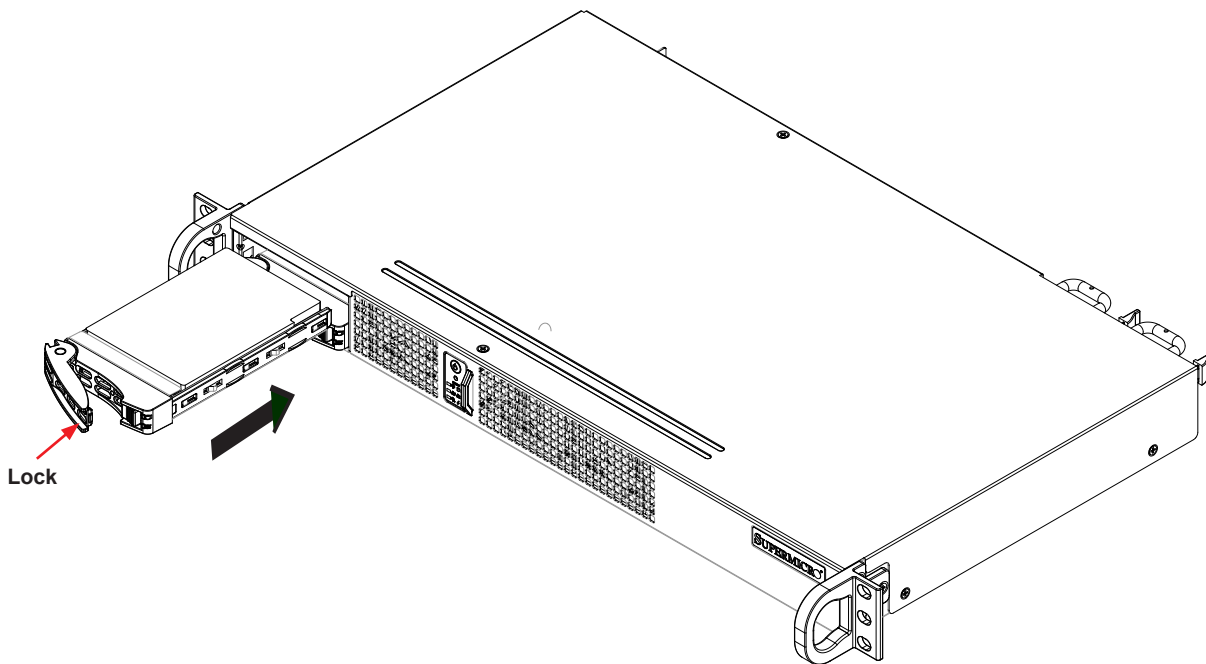

Figure 3-10. Installing the Hot Swappable Drive

## System Cooling

The SuperServer SYS-110A-16C/24C-RN10SP is cooled by up to three fans and an air shroud.

### System Fans

The fans can adjust their speed according to the heat level sensed in the system, which results in more efficient and quieter fan operation. Fan speed is controlled by IPMI. Each fan has its own separate tachometer.

If a fan fails, the remaining fans will ramp up to full speed, the overheat/fan fail LED on the control panel will blink on and off, and an alarm will sound. Replace any failed fan at your earliest convenience with the same type and model.

### Replacing a System Fan

1. Determine which fan has failed using remote management.
2. Once the failed fan has been identified, remove power from the system as described in Section 3.1.
3. Remove the chassis cover as described in Section 3.2.
4. Disconnect the failed fan from the motherboard.

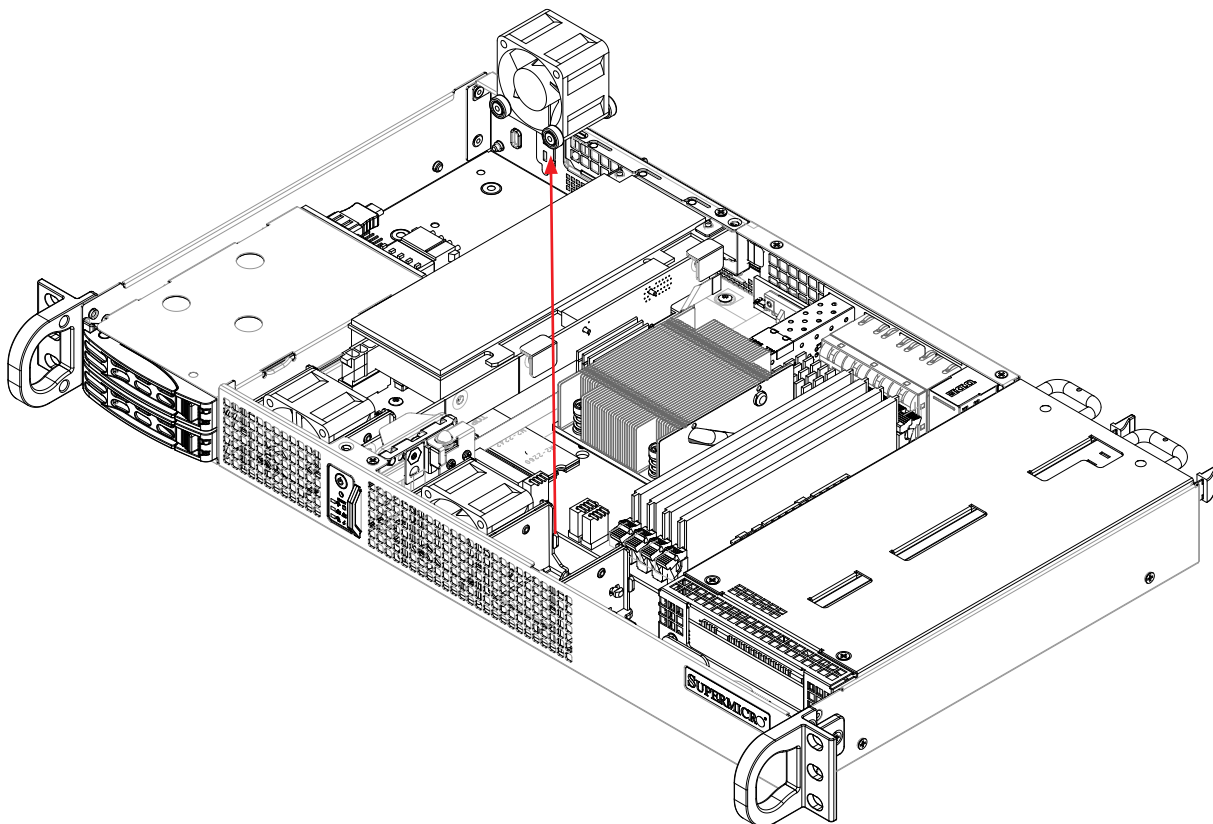

Figure 3-11. Removing Fans

5. Remove the failed fan from the fan tray.
6. In the fan tray, insert a new fan with the fan guard facing the chassis rear.
7. Reinstall the chassis cover.
8. Reconnect the power cord and power up the system.
9. Check that the overheat/fan fail LED on the control panel is off and that the sounding alarm is off.

### ***Checking the Server Air Flow***

- Make sure there are no objects to obstruct airflow in and out of the server.
- Use only recommended server parts.
- Make sure no wires or foreign objects obstruct air flow through the chassis. Pull all excess cabling out of the airflow path or use shorter cables.

The control panel LEDs display system heat status. See “Control Panel” in Chapter 1 for details.

### ***Overheating***

There are several possible responses if the system overheats.

#### ***If the server overheats:***

1. Use the overheat/fan fail LED to determine the nature of the overheating condition.
2. Confirm that the chassis covers are installed properly.
3. Make sure all fans are present and operating normally.
4. Check the routing of the cables.
5. Verify that the air shroud is installed properly.

## Power Supply

The CSE-506TS-R301P chassis has two 300W AC hot-swappable redundant power supplies. The power supplies are auto-switching capable. If replacing a power supply, the system does not need to be powered down. New units can be ordered directly from Supermicro or authorized distributors.

### Replacing a Power Supply

1. Use the system's remote management to find the failed power supply.
2. Check the power supply's LED.

Power Supply LED States	
LED Color	Definition
Off	No power input
Amber	Power supply is off or failed
Green	Power supply is on and operating

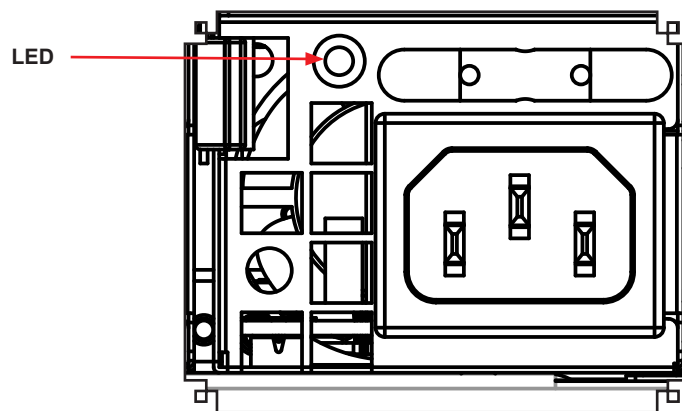

Figure 3-12. Power Supply Rear View

3. Disconnect the power cord from the power strip or outlet.
4. Disconnect the power cord from the power supply inlet.
5. Push the release tab on the back of the power supply as illustrated.
6. Using the handle, pull the power supply out of the chassis.
7. Slide the new power supply into the chassis until it clicks into place.
8. Reconnect the power cord to the power supply inlet.
9. Reconnect the power cord to the power strip or outlet.
10. Check the power supply's LED.
11. Use remote management to check the power supply status.

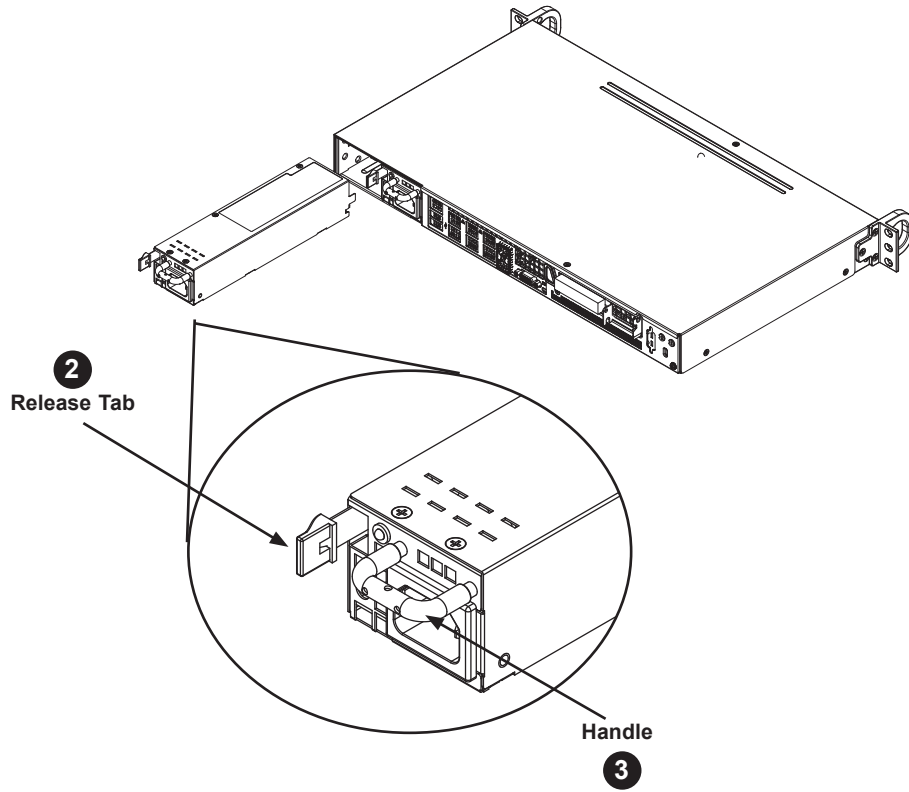

Figure 3-13. Removing the Power Supply

# Chapter 4

## Motherboard Connections

This section describes the connections on the motherboard and provides pinout definitions. Note that depending on how the system is configured, not all connections are required. The LEDs on the motherboard are also described here. A motherboard layout indicating component locations may be found in [Chapter 1](#). More detail can be found in the [Motherboard Manual](#).

Please review the Safety Precautions in [Appendix A](#) before installing or removing components.

### 4.1 Power Connections

#### Main ATX Power Supply Connector

The primary power supply connector (JPW1) meets the ATX SSI EPS 12V specification.

ATX Power 24-pin Connector Pin Definitions			
Pin#	Definition	Pin#	Definition
13	+3.3V	1	+3.3V
14	-12V	2	+3.3V
15	Ground	3	Ground
16	PS_ON	4	+5V
17	Ground	5	Ground
18	Ground	6	+5V
19	Ground	7	Ground
20	Res (NC)	8	PWR_OK
21	+5V	9	5VSB
22	+5V	10	+12V
23	+5V	11	+12V
24	Ground	12	+3.3V

#### 12V DC Power Connector

The 8-pin (JPV1) connector is used to provide alternative power for a special enclosure when the 24-pin ATX power is not in use.

8-pin Power Pin Definitions	
Pin#	Definition
1 - 4	Ground
5 - 8	P12V (12V Power)

### HDD Power Connector

JPH1 is a 4-pin power connector for HDD use. It provides power from the motherboard to the onboard HDDs.

4-pin HDD Power Pin Definitions	
Pin#	Definition
1	12V
2-3	GND
4	5V

## 4.2 Headers and Connectors

### Fan Headers

The A3SSV-16C/24C-SPLN10F has five 4-pin fan headers (FAN1 - FAN3, FANA, FANB). These headers are backwards-compatible with the traditional 3-pin fans. However, fan speed control is available for 4-pin fans only by Thermal Management via the IPMI 2.0 interface. Refer to the table below for pin definitions.

Fan Header Pin Definitions	
Pin#	Definition
1	Ground (Black)
2	2.5A/+12V (Red)
3	Tachometer
4	PWM_Control

### Speaker Header

JD1 is the speaker header. Connect the cable of the external speaker to pins 1-4.

Speaker Connector Pin Definitions	
Pin Setting	Definition
Pins 1-4	Speaker

### Chassis Intrusion

A Chassis Intrusion header is located at JL1 on the motherboard. Attach the appropriate cable from the chassis to inform you of a chassis intrusion when the chassis is opened. Refer to the table below for pin definitions.

Chassis Intrusion Pin Definitions	
Pin#	Definition
1	Intrusion Input
2	Ground

### Disk On Module Power Connector

The Disk-On-Module (DOM) power connector at JSD1 provides 5V power to a solid-state DOM storage device connected to one of the SATA ports. Refer the table below for pin definitions.

DOM Power Pin Definitions	
Pin#	Definition
1	5V
2	Ground
3	Ground

### General Purpose I/O Header

JGP1 is a 10-pin general purpose I/O header. Each pin can be configured to be an input or output pin. The GPIO is controlled via the PCA9554 8-bit GPIO expansion. The base address is 0xF040(D31:F4).

General Purpose I/O Header Pin Definitions		
Pin#	Definition	
1	+5V	+5V
2	Ground	Ground
3	GP0	GPP_E0
4	GP1	GPP_F1
5	GP2	GPP_E1
6	GP3	GPP_F2
7	GP4	GPP_E2
8	GP5	GPP_F3
9	GP6	GPP_F0
10	GP7	GPP_F4

### System Management Bus Header

A System Management Bus header for additional slave devices or sensors is located at JSMB1. Refer to the table below for pin definitions.

SMBus Header Pin Definitions	
Pin#	Definition
1	Data
2	Ground
3	Clock
4	NC

### BMC External I2C Header

A System Management Bus header for IPMI 2.0 is located at JIPMB1. Connect the appropriate cable here to use the IPMB I<sup>2</sup>C connection on your system. Refer to the table below for pin definitions.

External I <sup>2</sup> C Header Pin Definitions	
Pin#	Definition
1	Data
2	GND
3	Clock
4	NC

### Power SMB (I<sup>2</sup>C) Header

The Power System Management Bus (I<sup>2</sup>C) connector (JPI<sup>2</sup>C1) monitors the power supply, fan, and system temperatures. Refer to the table below for pin definitions.

Power SMB Header Pin Definitions	
Pin#	Definition
1	Clock
2	Data
3	PMBUS_Alert
4	Ground
5	NC

### TPM/Port 80 Header

A Trusted Platform Module (TPM)/Port 80 header is located at JTPM1 to provide TPM support and Port 80 connection. Use this header to enhance system performance and data security. Refer to the table below for pin definitions. Please go to the following link for more information on the TPM: <http://www.supermicro.com/manuals/other/TPM.pdf>.

Trusted Platform Module Header Pin Definitions			
Pin#	Definition	Pin#	Definition
1	+3.3V	2	SPI_CS#
3	RESET#	4	SPI_MISO
5	SPI_CLK	6	GND
7	SPI_MOSI	8	NC
9	+3.3V Stdby	10	SPI_IRQ#

### SATA Ports

There are six SATA 2.0 ports on the A3SSV-16C/24C-SPLN10F motherboard. I-SATA0 has the SuperDOM feature.

SATA 2.0 Port Pin Definitions	
Pin#	Signal
1	Ground
2	SATA_TXP
3	SATA_TXN
4	Ground
5	SATA_RXN
6	SATA_RXP
7	Ground

## M.2 Slot

The A3SSV-8C/16C/24C-SPLN10F motherboard has three M.2 slots (JMD1, JMD2, and JMD3). M.2 was formerly known as Next Generation Form Factor (NGFF) and serves to replace mini PCIe. M.2 allows for a variety of card sizes, increased functionality, and spatial efficiency. JMD1 supports PCIe 2.0 x4/SATA 2.0/USB 2.0 cards in the M-Key 2242/2280/22110 form factors, JMD2 supports PCIe 2.0 x2/SATA 2.0/USB 3.0 cards in the B-Key 2242/3042/2280 form factors, and JMD3 supports PCIe 2.0 x1/USB2.0 cards in the M.2 E-Key 2230 form factor.

## Thermal Diode Header

JRT3 is the thermal diode 1 header. This is a thermal sensor header that provides additional system temperature monitoring.

Thermal Diode 1 Pin Definitions	
Pin#	Definition
1	TD1_P
2	TD1_N

## LAN Port Activity LED

JLANLED1 is the activity LED header for LAN3 and LAN4, JLANLED2 is the activity LED header for LAN5–LAN8, and JLANLED3 is the activity LED header for LAN9 and LAN10.

JLANLED1 LAN Activity LED Pin Definitions			
Pin#	Definition	Pin#	Definition
1	LAN3_ACT_N	2	P3V3 Dual
3	LAN4_ACT_N	4	P3V3 Dual

JLANLED3 LAN Activity LED Pin Definitions			
Pin#	Definition	Pin#	Definition
1	LAN9_ACT_N	2	P3V3 Dual
3	LAN10_ACT_N	4	P3V3 Dual

JLANLED2 LAN Activity LED Pin Definitions			
Pin#	Definition	Pin#	Definition
2	LAN5_ACT_N	1	P3V3 Dual
4	LAN6_ACT_N	3	P3V3 Dual
6	LAN7_ACT_N	5	P3V3 Dual
8	LAN8_ACT_N	7	P3V3 Dual

### Front RJ45 Link and Activity LED Header

JFPCLED1 is the 1GbE RJ45 link and activity LED header. Attach a cable from this header to the Supermicro LED board (Part Number: FPB-FPE300-LED10) to display the status of the RJ45 LAN link and activity LED. The LED board FPB-FPE300-LED10 is reserved for use on the E300 chassis.

### Front SFP Link and Activity LED Header

JSPFLED1 is the 1GbE SFP link and activity LED header. Attach a cable from this header to the Supermicro LED board (Part Number: FPB-FPE300-LED10) to display the status of the SFP link and activity LED.

### Software-Defined Pins (SDP)

JSDP1 and JSDP2 are software-defined pins that can be used to support IEEE 1588 auxiliary devices and other hardware or software-control purposes. These pins can be configured to function as standard inputs or General Purpose Interrupt (GPI) input or output pins. In order for pins to function as GPI, they must be configured as inputs and enabled by the PCH Ethernet or i350.

JSDP1 Pin Definitions	
Pin#	Definition
1	SDP_TIMESYNC0
2	SDP_TIMESYNC1
3	SDP_TIMESYNC2
4	SDP_TIMESYNC3
5	GND

JSDP2 Pin Definitions	
Pin#	Definition
1	I350_SDP0_0
2	I350_SDP0_1
3	I350_SDP0_2
4	I350_SDP0_3
5	GND

## 4.3 Input/Output Ports

See the figure below for the locations and descriptions of the I/O ports on the rear of the motherboard.

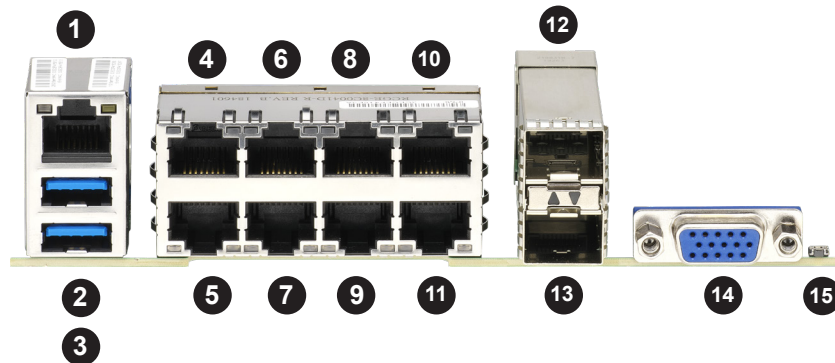

Figure 4-1. I/O Port Locations and Definitions

Rear I/O Ports					
#	Description	#	Description	#	Description
1	IPMI LAN	6	LAN4	11	LAN9
2	USB1 (USB3.0)	7	LAN3	12	LAN6
3	USB0 (USB3.0)	8	LAN8	13	LAN5
4	LAN2	9	LAN7	14	VGA
5	LAN1	10	LAN10	15	UID Switch

### VGA Port

A VGA port is located on the I/O back panel. Use this port to connect to a compatible VGA display.

### LAN Ports

The motherboard supports eight RJ45 GbE LAN ports on LAN1–4, LAN7–10 and two SFP+ LAN ports on LAN5–6. In addition to the LAN ports, there is one IPMI LAN port.

LAN Port Pin Definition			
Pin#	Definition	Pin#	Definition
1	TD0-	11	P3V3_Dual
2	TD0+	12	Act LED (Yellow)
3	TD1-	13	Link 1000 (Amber)
4	TD1+	14	Link 100 LED (Green)
5	TD2-	15	GND
6	TD2+	16	GND
7	TD3-	17	GND
8	TD3+	18	GND
9	COMMCT		
10	GND		

IPMI LAN Pin Definition			
Pin#	Definition	Pin#	Definition
19	VCC	31	YEL+
20	TX1+	32	YEL-
21	TX1-	29	ORG-/GRN+
22	TX2+	30	ORG+/GRN-
23	TX2-	37	CG5
24	TX3+	38	CG6
25	TX3-	39	CG7
26	TX4+	40	CG8
27	TX4-		
28	GND		

## COM Headers

The motherboard has two front accessible COM headers (COM1 and COM2) to provide serial connections.

COM Header Pin Definitions			
Pin#	Definition	Pin#	Definition
1	DCD	6	DSR
2	RXD	7	RTS
3	TXD	8	CTS
4	DTR	9	RI
5	Ground	10	N/A

## Universal Serial Bus (USB) Ports

There are two USB 3.0 ports (USB0/1) on the back panel I/O and one USB header (USB2/3). The onboard header can be used to provide front side USB access with a cable (not included).

Back Panel USB 3.0 Ports (USB0/1) Pin Definitions			
Pin#	Definition	Pin#	Definition
14	STDA_SSRX2N	10	VBUS2
15	STDA_SSRX2P	11	D2N
16	GND_DRAIN	12	D2P
17	STDA_SSTX2N	13	GND
18	STDA_SSTX2P		
5	STDA_SSRX1N	1	VBUS1
6	STDA_SSRX1P	2	D1N
7	GND_DRAIN	3	D1P
8	STDA_SSTX1N	4	GND
9	STDA_SSTX1P	33	CG1
		34	CG2
		35	CG3
		36	CG4

USB 2.0 Header (USB2/3) Pin Definitions			
Pin#	Definition	Pin#	Definition
1	+5V	2	+5V
3	USB_N	4	USB_N
5	USB_P	6	USB_P
7	Ground	8	Ground
9	Key	10	NC

### Unit Identifier Switch/UID LED Indicator

A Unit Identifier (UID) switch and an LED Indicator are located on the motherboard. The UID switch is located at UID SW, which is next to the Display Port on the back panel. The UID LED is located next to the UID switch. When you press the UID switch, the UID LED will be turned on. Press the UID switch again to turn off the LED indicator. The UID Indicator provides easy identification of a system unit that may be in need of service.

**Note:** UID can also be triggered via IPMI on the motherboard. For more information on IPMI, please refer to the IPMI User's Guide posted on our website at <https://www.supermicro.com/support/manuals/>.

UID Button Pin Definitions	
Pin#	Definition
1	Ground
2	Ground
3	Button In
4	Button In

UID LED Pin Definitions	
Color	Status
Blue: On	Unit Identified

## 4.4 Jumpers

### How Jumpers Work

To modify the operation of the motherboard, jumpers can be used to choose between optional settings. Jumpers create shorts between two pins to change the function of the connector. Pin 1 is identified with a square solder pad on the printed circuit board. Refer to the diagram below for an example of jumping pins 1 and 2. Refer to the motherboard layout page for jumper locations.

**Note:** On two-pin jumpers, "Closed" means the jumper is on, and "Open" means the jumper is off the pins.

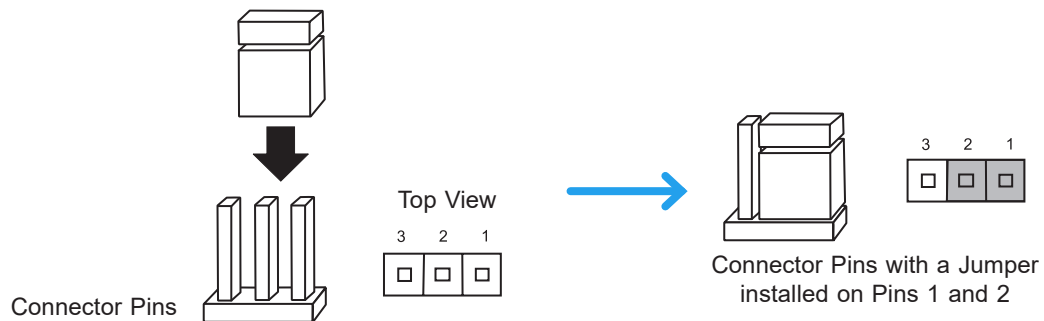

### CMOS Clear

JBT1 is used to clear CMOS, which will also clear any passwords. Instead of pins, this jumper consists of contact pads to prevent accidentally clearing the contents of CMOS.

#### To Clear CMOS

1. First power down the system and unplug the power cord(s). 
2. Remove the cover of the chassis to access the motherboard and remove the battery from the motherboard.
3. Short the CMOS pads with a metal object such as a small screwdriver for at least four seconds.
4. Remove the screwdriver (or shorting device).
5. Re-install the motherboard battery.
6. Replace the cover, reconnect the power cord(s), and power on the system.

**Note 1:** Clearing CMOS will also clear all passwords.

**Note 2:** Do not use the PW\_ON connector to clear CMOS.

## LAN Port Enable/Disable

Change the setting of jumpers JPL1 for LAN1–4.

LAN Enable/Disable Jumper Settings	
Jumper Setting	Definition
Pins 1-2	Enabled (Default)
Pins 2-3	Disabled

## Watch Dog

JWD1 controls the Watch Dog function. Watch Dog is a monitor that can reboot the system when a software application hangs. Jumping pins 1-2 will cause Watch Dog to reset the system if an application hangs. Jumping pins 2-3 will generate a non-maskable interrupt signal for the application that hangs. Watch Dog must also be enabled in BIOS. The default setting is Reset.

**Note:** When Watch Dog is enabled, users need to write their own application software to disable it.

Watch Dog Jumper Settings	
Jumper Setting	Definition
Pins 1-2	Reset (Default)
Pins 2-3	NMI
Open	Disabled

## Manufacturing Mode Select

Close pins 2-3 of jumper JPME2 to bypass SPI flash security and force the system to operate in the manufacturing mode, which will allow you to flash the system firmware from a host server for system setting modifications. Refer to the table below for jumper settings.

Manufacturing Mode Jumper Settings	
Jumper Setting	Definition
Pins 1-2	Normal (Default)
Pins 2-3	Manufacturing Mode

### VGA Enable/Disable

Use jumper JPG1 to enable or disable the onboard VGA port. Refer to the table below for jumper settings.

VGA Enable/Disable Jumper Settings	
Jumper Setting	Definition
Pins 1-2	Enabled (Default)
Pins 2-3	Disabled

### IPMI Share LAN Enable/Disable

Set the JBM1 jumper to enabled to share i350 LAN with IPMI.

IPMI Share LAN Enable/Disable Jumper Settings	
Jumper Setting	Definition
Pins 1-2 (Open)	Enabled (Default)
Pins 1-2 (Short)	Disabled

### IPMI Dedicated LAN Enable/Disable

Use JBM2 to enable or disable the dedicated IPMI LAN port. Refer to the table below for jumper settings.

IPMI Dedicated LAN Enable/Disable Jumper Settings	
Jumper Setting	Definition
Pins 1-2 (Open)	Enabled (Default)
Pins 1-2 (Short)	Disabled

### Power Force On

Use this jumper JPF1 to select the POWER FORCE ON function when the AC power cord is plugged in.

Power Force On Jumper Settings	
Jumper Setting	Definition
Pins 1-2	ATX Mode (when AC power cord is plugged)
Pins 2-3	Force PS-ON Mode (Default) (when AC power cord is plugged)

## 4.5 LED Indicators

### LAN LEDs

Eight RJ45 LAN ports and two SFP LAN ports are located on the I/O back panel. Each Ethernet LAN port has two LEDs. One LED indicates activity, while the other Link LED may be green, amber, or off to indicate the speed of the connection. Refer to the tables below for more information. When the system is in the S1/S3/S4/S5 states, the LAN Link LED will be in the solid on state.

Activity Indicator		
Color	Status	Definition
Off	No Connection	
Yellow	Flashing	Active

1G RJ45 LAN Link	
LED Color	Definition
Off	No Connection or 10 Mb/s
Green	100 Mb/s
Amber	1 Gb/s

SFP28 LAN Link LED (LAN5 - LAN6)	
LED Color	Definition
Off	No Connection
Amber	1G

Activity Indicator		
Color	Status	Definition
Off	No Connection	
Yellow	Flashing	Active

### Power LED

LED1 is an onboard power LED. When this LED is lit, it means power is present on the motherboard. In suspend mode, this LED will blink on and off. Be sure to turn off the system and unplug the power cord(s) before removing or installing components.

Onboard Power LED Indicator	
LED Color	Definition
Off	System Off (power cable not connected)
Green	System On

### BMC Heartbeat LED

LEDM1 is the BMC heartbeat LED. When the LED is blinking green, BMC is working. Refer to the table below for the LED status.

BMC Heartbeat LED Indicator	
LED Color	Definition
Blinking Green	BMC Normal

## 4.6 Front Control Panel

JF1 contains header pins for various buttons and indicators that are normally located on a control panel at the front of the chassis. These connectors are designed specifically for use with Supermicro chassis. See the figure below for the descriptions of the front control panel buttons and LED indicators.

### Power Button

The Power Button connection is located on pins 1 and 2 of JF1. Momentarily contacting both pins will power on/off the system. This button can also be configured to function as a suspend button (with a setting in the BIOS - see Chapter 4). To turn off the power when the system is in suspend mode, press the button for 4 seconds or longer. Refer to the table below for pin definitions.

Power Button Pin Definitions (JF1)	
Pin#	Definition
1	Signal
2	Ground

### Reset Button

The Reset Button connection is located on pins 3 and 4 of JF1. Attach it to a hardware reset switch on the computer case. Refer the table below for pin definitions.

Reset Button Pin Definitions (JF1)	
Pin#	Definition
3	Reset
4	Ground

### Overheat (OH)/Fan Fail

Connect an LED cable to pins 7 and 8 to use the Overheat/Fan Fail LED connections. The LED on pin 8 provides warnings of overheat or fan failure. Refer to the tables below for pin definitions.

OH/Fan Fail Indicator Status	
State	Definition
Off	Normal
On	Overheat
Flashing	Fan Fail

OH/Fan Fail LED Pin Definitions (JF1)	
Pin#	Definition
7	RED+
8	Blue+

### NIC1/NIC2 (LAN1/LAN2)

The NIC (Network Interface Controller) LED connection for LAN port 1 is located on pins 11 and 12 of JF1, and LAN port 2 is on pins 9 and 10. Attach the NIC LED cables here to display network activity. Refer to the table below for pin definitions.

NIC1/NIC2 LED Pin Definitions (JF1)	
Pin#	Definition
9	3.3V SB
10	LAN2 Active LED
11	3.3V SB
12	LAN1 Active LED

### HDD LED

The HDD LED connection is located on pins 13 and 14 of JF1. Attach a cable to show hard drive activity status. Refer to the table below for pin definitions.

HDD LED Pin Definitions (JF1)	
Pin#	Definition
13	ID_UID/3.3V SB
14	HDD LED

### Power LED

The Power LED connection is located on pins 15 and 16 of JF1. Refer to the table below for pin definitions.

Power LED Pin Definitions (JF1)	
Pin#	Definition
15	3.3V
16	PWR LED

### NMI Button

The non-maskable interrupt button header is located on pins 19 and 20 of JF1. Refer to the table below for pin definitions.

NMI Button Pin Definitions (JF1)	
Pins	Definition
19	NMI
20	Ground

# Chapter 5

## Software

After the hardware has been installed, you can install the Operating System (OS), configure RAID settings and install the drivers.

### 5.1 Microsoft Windows OS Installation

If you will be using RAID, you must configure RAID settings before installing the Windows OS and the RAID driver. Refer to the RAID Configuration User Guides posted on our website at [www.supernmicro.com/support/manuals](http://www.supernmicro.com/support/manuals).

#### *Installing the OS*

1. Create a method to access the Microsoft Windows installation ISO file. That can be a USB flash, media drive, or the BMC KVM console.
2. Retrieve the proper RST/RSTe driver. Go to the Supermicro web page for your motherboard and click on "Download the Latest Drivers and Utilities", select the proper driver, and copy it to a USB flash drive.
3. Boot from a bootable device with Windows OS installation. You can see a bootable device list by pressing **F11** during the system startup.

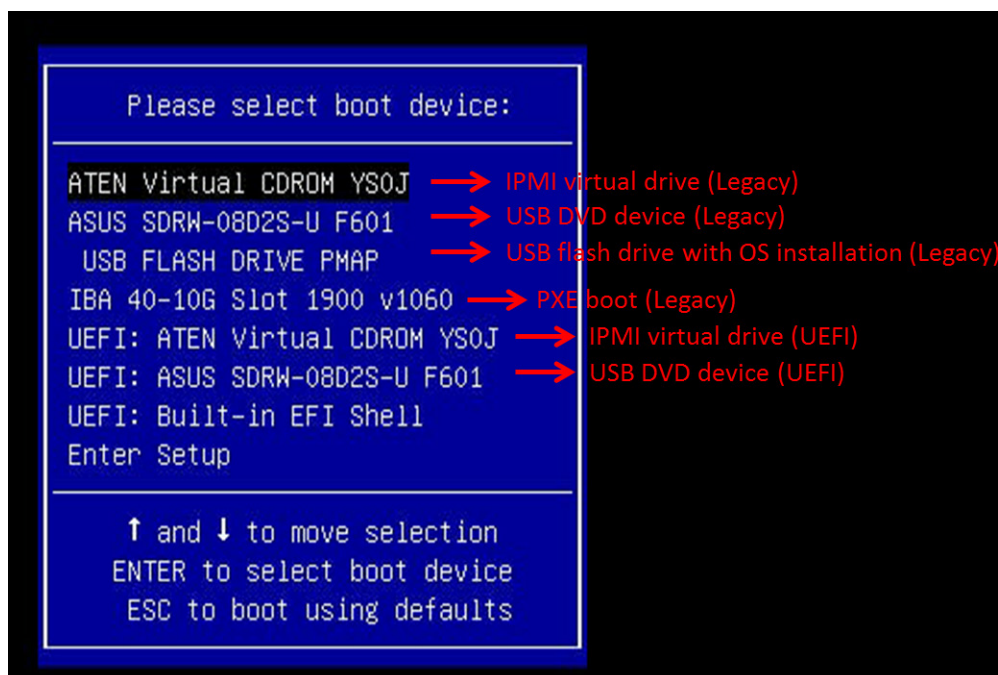
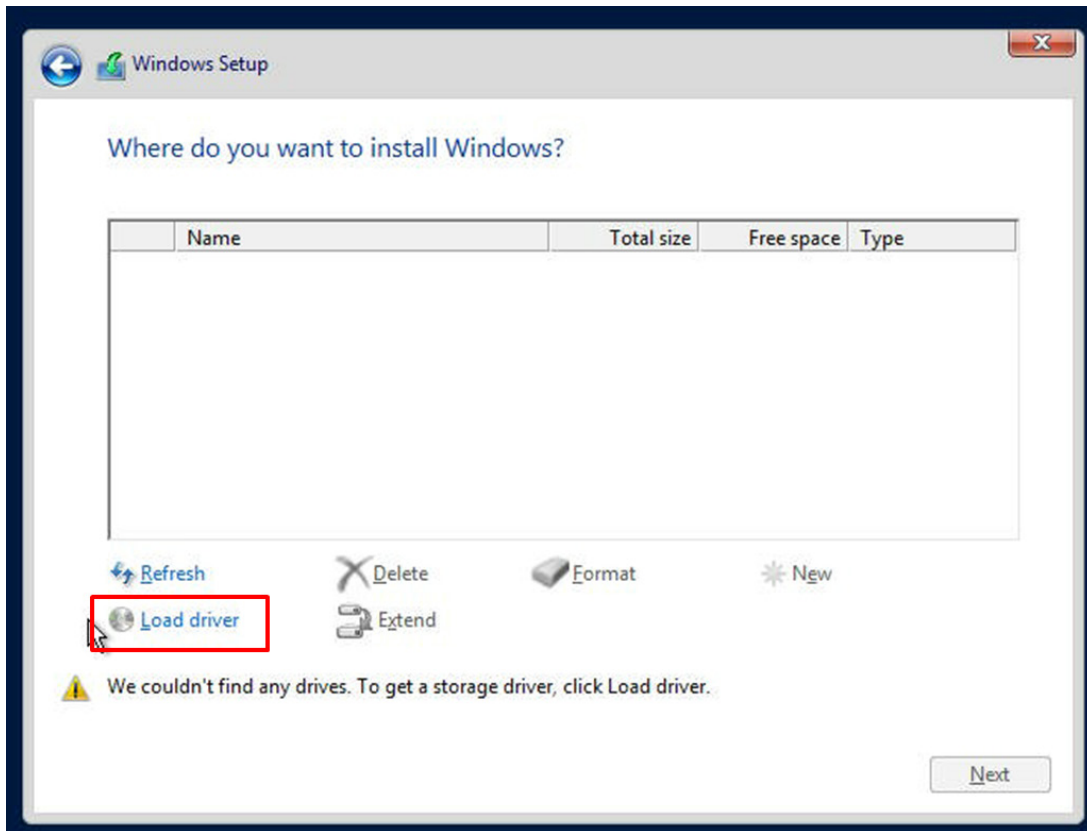

Figure 5-1. Select Boot Device

4. During Windows Setup, continue to the dialog where you select the drives on which to install Windows. If the disk you want to use is not listed, click on “Load driver” link at the bottom left corner.



**Figure 5-2. Load Driver Link**

To load the driver, browse the USB flash drive for the proper driver files.

- For RAID, choose the SATA/sSATA RAID driver indicated then choose the storage drive on which you want to install it.
  - For non-RAID, choose the SATA/sSATA AHCI driver indicated then choose the storage drive on which you want to install it.
5. Once all devices are specified, continue with the installation.
  6. After the Windows OS installation has completed, the system will automatically reboot multiple times.

## 5.2 Driver Installation

The Supermicro website contains drivers and utilities for your system at <https://www.supermicro.com/wdl/driver>. Some of these must be installed, such as the chipset driver.

After accessing the website, go into the CDR\_Images (in the parent directory of the above link) and locate the ISO file for your motherboard. Download this file to a USB flash drive or media drive (you may also use a utility to extract the ISO file if preferred).

Another option is to go to the Supermicro website at <http://www.supermicro.com/products/>. Find the product page for your motherboard, and "Download the Latest Drivers and Utilities".

Insert the flash drive or disk and the screenshot shown below should appear.

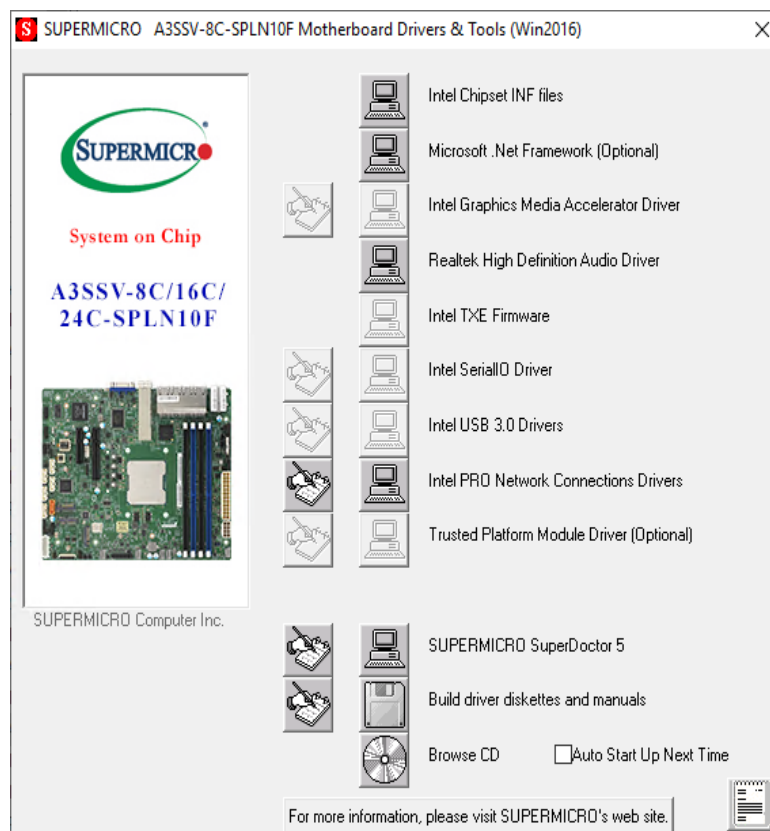

**Figure 5-3. Driver & Tool Installation Screen**

**Note:** Click the icons showing a hand writing on paper to view the readme files for each item. Click the computer icons to the right of these items to install each item (from top to the bottom) one at a time. **After installing each item, you must re-boot the system before moving on to the next item on the list.** The bottom icon with a CD on it allows you to view the entire contents.

## 5.3 SuperDoctor® 5

The Supermicro SuperDoctor 5 is a program that functions in a command-line or web-based interface for Windows and Linux operating systems. The program monitors such system health information as CPU temperature, system voltages, system power consumption, fan speed, and provides alerts via email or Simple Network Management Protocol (SNMP).

SuperDoctor 5 comes in local and remote management versions and can be used with Nagios to maximize your system monitoring needs. With SuperDoctor 5 Management Server (SSM Server), you can remotely control power on/off and reset chassis intrusion for multiple systems with SuperDoctor 5 or BMC. SuperDoctor 5 Management Server monitors HTTP, FTP, and SMTP services to optimize the efficiency of your operation.

### SuperDoctor® Manual and Resources

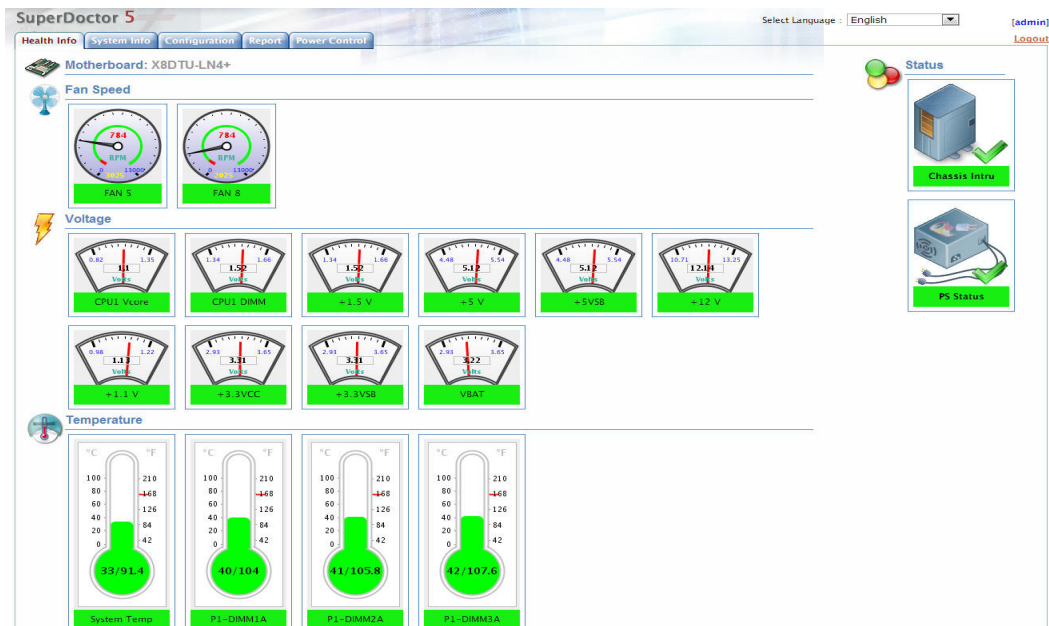

Figure 5-4. SuperDoctor 5 Interface Display Screen (Health Information)

## 5.4 BMC

The motherboard provides remote access, monitoring and management through the baseboard management controller (BMC) and other management controllers distributed among different system modules. There are several BIOS settings that are related to BMC. For general documentation and information on BMC, visit our website at:

[www.supermicro.com/en/solutions/management-software/bmc-resources](http://www.supermicro.com/en/solutions/management-software/bmc-resources)

### BMC ADMIN User Password

For security, each system is assigned a unique default BMC password for the ADMIN user. This can be found on a sticker on the chassis and a sticker on the motherboard. The sticker also displays the BMC MAC address.



Figure 5-5. BMC Password Label

## Chapter 6

# Optional Components

This chapter describes optional system components and installation procedures.

### 6.1 Optional Parts List

Optional Parts List	
Description	Part Number
Fix Rail Kit Set	MCP-290-50404-0N

## Chapter 7

# Troubleshooting and Support

## 7.1 Information Resources

### Website

A great deal of information is available on the Supermicro website, [supermicro.com](http://supermicro.com).



**Figure 7-1. Supermicro Website**

- Specifications for servers and other hardware are available by clicking the **Products** option.
- The **Support** option offers downloads (manuals, BIOS/BMC, drivers, etc.), FAQs, RMA, warranty, and other service extensions.

### ***Direct Links for the SYS-110A-16C/24C-RN10SP System***

[SYS-110A-16C-RN10SP](#), [SYS-110A-24C-RN10SP](#) specifications page

[A3SSV-16C-SPLN10F](#), [A3SSV-24C-SPLN10F](#) motherboard page for links to the Quick Reference Guide, User Manual, validated storage drives, etc.

### ***Direct Links for General Support and Information***

[Frequently Asked Questions](#)

[Add-on card descriptions](#)

[TPM User Guide](#)

[BMC User Guide](#)

[SuperDoctor5 Large Deployment Guide](#)

## Direct Links (continued)

For validated memory, use our [Product Resources page](#)

[Product Matrices](#) page for links to tables summarizing specs for systems, motherboards, power supplies, riser cards, add-on cards, etc.

[Security Center](#) for recent security notices

[Supermicro Phone and Addresses](#)

## 7.2 Baseboard Management Controller (BMC)

The system supports the Baseboard Management Controller (BMC). BMC is used to provide remote access, monitoring and management. There are several BIOS settings that are related to BMC.

For general documentation and information on BMC, please visit our website at: <https://www.supermicro.com/en/solutions/management-software/bmc-resources>.

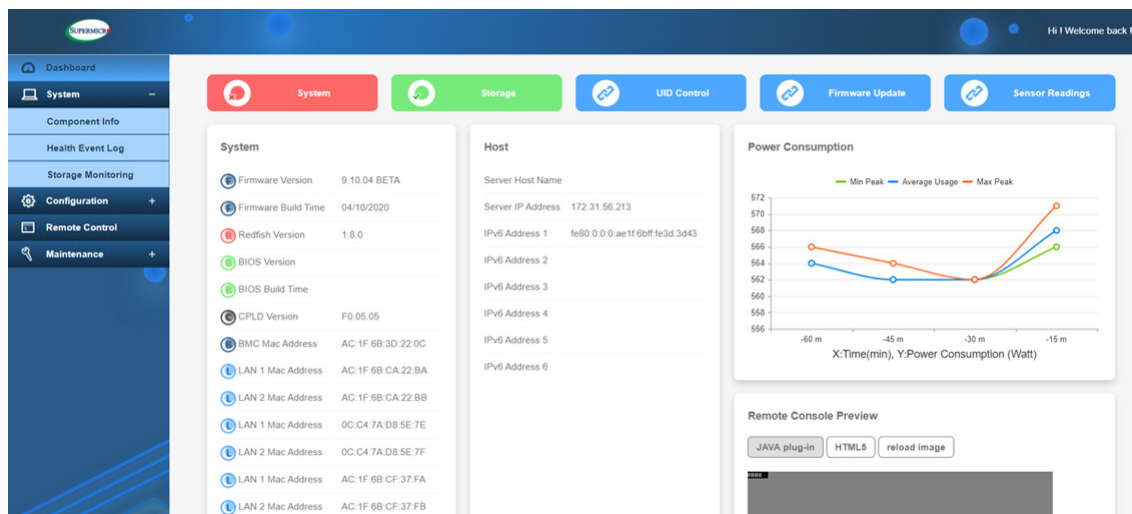

Figure 7-2. BMC Sample

## 7.3 Troubleshooting Procedures

Use the following procedures to troubleshoot your system. If you have followed all of the procedures below and still need assistance, refer to the [Technical Support Procedures](#) or [Returning Merchandise for Service](#) section(s) in this chapter. [Power down](#) the system before changing any non hot-swap hardware components.

### General Technique

If you experience unstable operation or get no boot response, try:

1. With power off, remove all but one DIMM and other added components, such as add-on cards, from the motherboard. Make sure the motherboard is not shorted to the chassis.
2. Set all jumpers to their default positions.
3. Power up. If the system boots, check for memory errors and add-on card problems.

### No Power

- Check that the power LED on the motherboard is on.

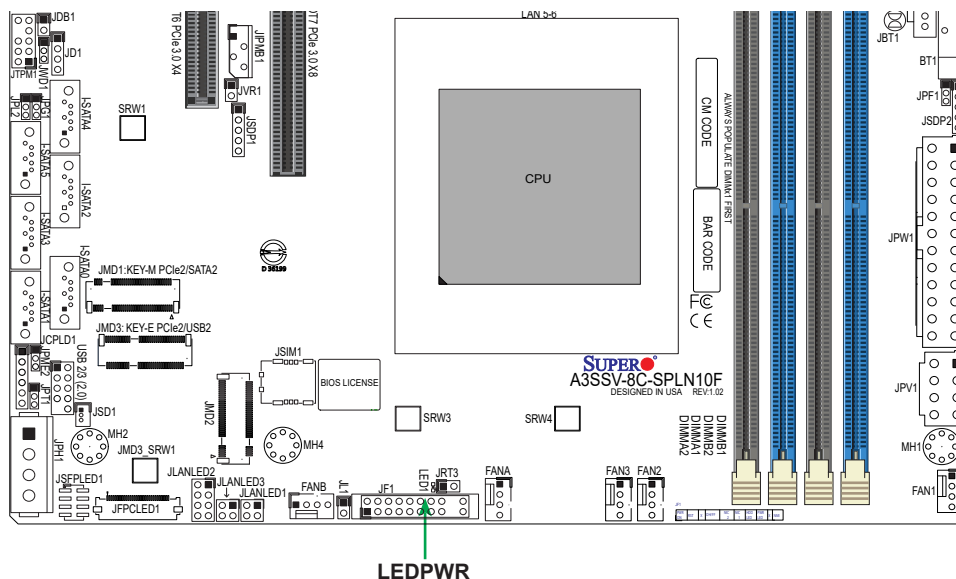

Figure 7-3. Location of the MB Power LED

- Make sure that the power connector is connected to the power supply.
- Check that the motherboard battery still supplies approximately 3VDC. If it does not, replace it.
- Check that the system input voltage is 100-120VAC or 180-240VAC.
- Turn the power switch on and off to test the system

## No Video

If the power is on but you have no video, remove all add-on cards and cables.

## System Boot Failure

If the system does not display Power-On-Self-Test (POST) or does not respond after the power is turned on, try the following:

- Turn on the system with only one DIMM module installed. If the system boots, check for bad DIMM modules or slots by following the Memory Errors Troubleshooting procedure below.

## Memory Errors

- Make sure that the DIMM modules are properly and fully installed.
- Confirm that you are using the correct memory. Also, it is recommended that you use the same memory type and speed for all DIMMs in the system. See Section 3.5 for memory details.
- Check for bad DIMM modules or slots by swapping modules between slots and noting the results.

## Losing the System Setup Configuration

- Always replace power supplies with the exact same model that came with the system. A poor quality power supply may cause the system to lose the CMOS setup configuration.
- Check that the motherboard battery still supplies approximately 3VDC. If it does not, replace it.

If the above steps do not fix the setup configuration problem, contact your vendor for repairs.

## When the System Becomes Unstable

*If the system becomes unstable during or after OS installation, check the following:*

- CPU/BIOS support: Make sure that your CPU is supported and that you have the latest BIOS installed in your system.
- Memory: Make sure that the memory modules are supported. Refer to the product page on our website at [www.supermicro.com](http://www.supermicro.com). Test the modules using **memtest86** or a similar utility.
- Storage drives: Make sure that all drives work properly. Replace if necessary.

- System cooling: Check that all heatsink fans and system fans work properly. Check the hardware monitoring settings in the BMC to make sure that the CPU and system temperatures are within the normal range. Also check the Control panel Overheat LED.
- Adequate power supply: Make sure that the power supply provides adequate power to the system. Make sure that all power connectors are connected. Refer to the Supermicro website for the minimum power requirements.
- Proper software support: Make sure that the correct drivers are used.

***If the system becomes unstable before or during OS installation, check the following:***

- Source of installation: Make sure that the devices used for installation are working properly, including boot devices.
- Cable connection: Check to make sure that all cables are connected and working properly.
- Use the minimum configuration for troubleshooting: Remove all unnecessary components (starting with add-on cards first), and use the minimum configuration (but with a CPU and a memory module installed) to identify the trouble areas.
- Identify a bad component by isolating it. Check and change one component at a time.
  - Remove a component in question from the chassis, and test it in isolation. Replace it if necessary.
  - Or swap in a new component for the suspect one.
  - Or install the possibly defective component into a known good system. If the new system works, the component is likely not the cause or the problem.

## 7.4 Crash Dump Using BMC

In the event of a processor internal error (IERR) that crashes your system, you may want to provide information to support staff. You can download a crash dump of status information using BMC. The BMC manual is available at <https://www.supermicro.com/en/solutions/management-software/bmc-resources>.

### Check BMC Error Log

1. Access the BMC web interface.

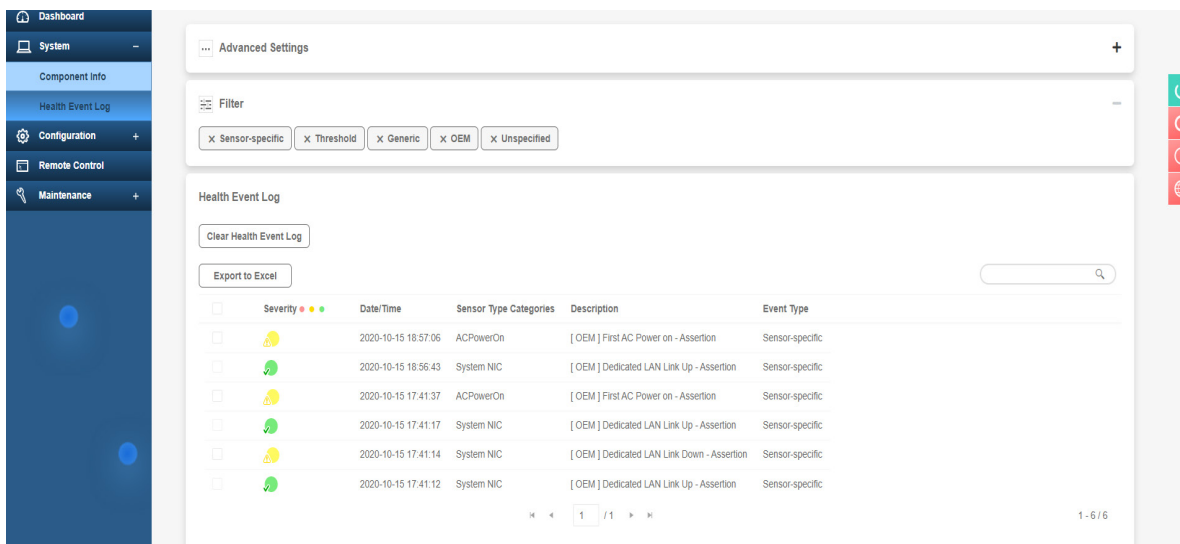

Figure 7-4. BMC Event Log

2. Click the **Server Health** tab, then **Event Log** to verify an IERR error.

In the event of an IERR, the BMC executes a crash dump. You must download the crash dump and save it.

## 7.5 UEFI BIOS Recovery

**Warning:** Do not upgrade the BIOS unless your system has a BIOS-related issue. Flashing the wrong BIOS can cause irreparable damage to the system. In no event shall Supermicro be liable for direct, indirect, special, incidental, or consequential damages arising from a BIOS update. If you do update the BIOS, do not shut down or reset the system while the BIOS is updating to avoid possible boot failure.

### Overview

The Unified Extensible Firmware Interface (UEFI) provides a software-based interface between the operating system and the platform firmware in the pre-boot environment. The UEFI specification supports an architecture-independent mechanism that will allow the UEFI OS loader stored in an add-on card to boot the system. The UEFI offers clean, hands-off management to a computer during system boot.

### Recovering the UEFI BIOS Image

A UEFI BIOS flash chip consists of a recovery BIOS block and a main BIOS block (a main BIOS image). The recovery block contains critical BIOS codes, including memory detection and recovery codes for the user to flash a healthy BIOS image if the original main BIOS image is corrupted. When the system power is turned on, the recovery block codes execute first. Once this process is complete, the main BIOS code will continue with system initialization and the remaining POST (Power-On Self-Test) routines.

**Note 1:** Follow the BIOS recovery instructions below for BIOS recovery when the main BIOS block crashes.

**Note 2:** When the BIOS recovery block crashes, you will need to follow the procedures to make a Returned Merchandise Authorization (RMA) request. Also, you may use the Supermicro Update Manager (SUM) Out-of-Band ([https://www.supermicro.com.tw/products/nfo/SMS\\_SUM.cfm](https://www.supermicro.com.tw/products/nfo/SMS_SUM.cfm)) to reflash the BIOS.

### Recovering the Main BIOS Block with a USB Device

This feature allows the user to recover the main BIOS image using a USB-attached device without additional utilities used. A USB flash device such as a USB Flash Drive, or a USB CD/DVD ROM/RW device can be used for this purpose. However, a USB Hard Disk drive cannot be used for BIOS recovery at this time.

The file system supported by the recovery block is FAT (including FAT12, FAT16, and FAT32) which is installed on a bootable or non-bootable USB-attached device. However, the BIOS might need several minutes to locate the SUPER.ROM file if the media size becomes too large due to the huge volumes of folders and files stored in the device.

To perform UEFI BIOS recovery using a USB-attached device, follow the instructions below.



**Note:** At this point, you may decide if you want to start the BIOS recovery. If you decide to proceed with BIOS recovery, follow the procedures below.

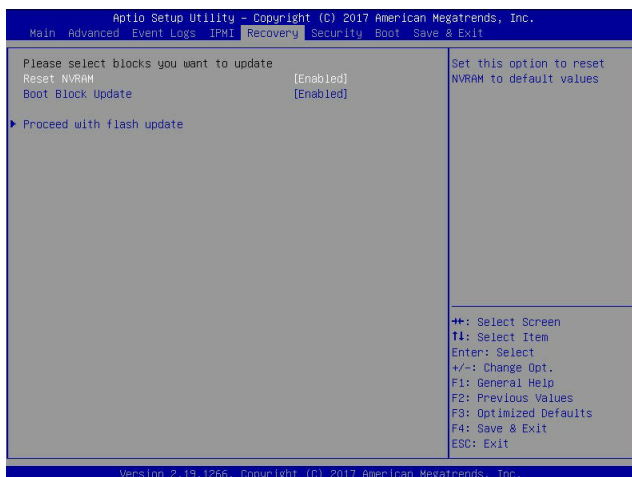

4. When the screen as shown above displays, use the arrow keys to select the item "Proceed with flash update" and press the <Enter> key. You will see the BIOS recovery progress as shown in the screen below.

**Note:** *Do not interrupt the BIOS flashing process until it has completed.*

5. After the BIOS recovery process is complete, press any key to reboot the system.
6. Using a different system, extract the BIOS package into a USB flash drive.

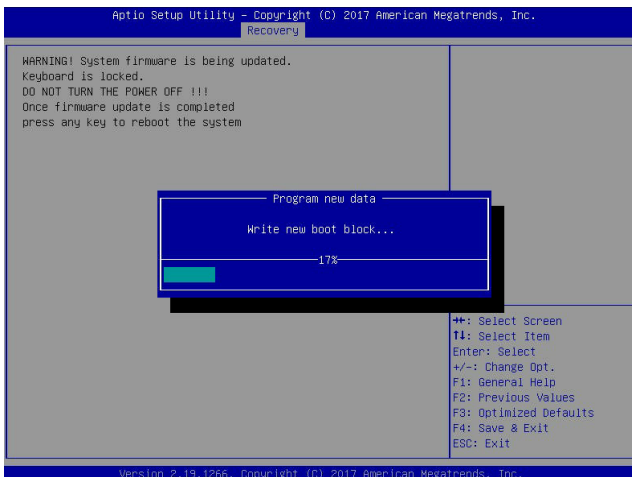

7. Press <Del> continuously during system boot to enter the BIOS Setup utility. From the top of the tool bar, select Boot to enter the submenu. From the submenu list, select Boot

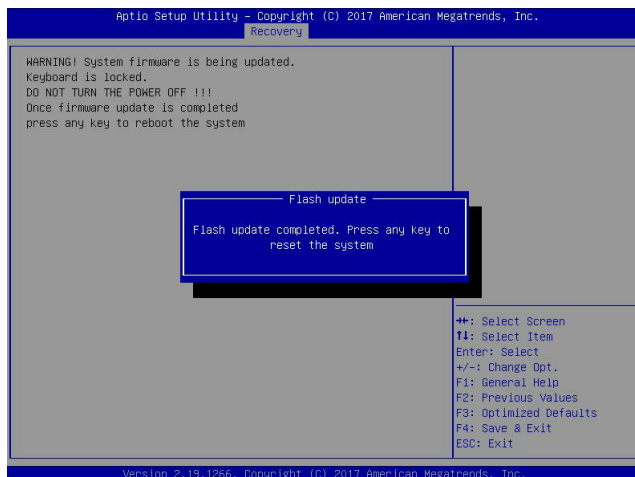

Option #1 as shown below. Then, set Boot Option #1 to [UEFI AP:UEFI: Built-in EFI Shell]. Press <F4> to save the settings and exit the BIOS Setup utility.

8. When the UEFI Shell prompt appears, type fs# to change the device directory path. Go to the directory that contains the BIOS package you extracted earlier from Step 6. Enter flash.nsh BIOSname.### at the prompt to start the BIOS update process.

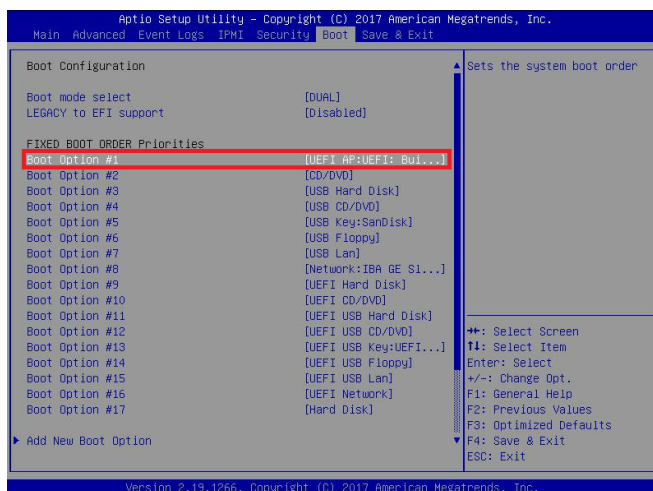

**Note:** Do not interrupt this process until the BIOS flashing is complete.

```

UEFI Interactive Shell v2.1
EDK II
UEFI v2.50 (American Megatrends, 0x0005000C)
Mapping table
  FS0: Alias(s):HD0:0B:BLK1:
        PciRoot(0x0)/Pci(0x14,0x0)/USB(0x11,0x0)/HD(1,MBR,0x37901D72,0x800,0x1
CR9592)
  BLK0: Alias(s):
        PciRoot(0x0)/Pci(0x14,0x0)/USB(0x11,0x0)
Press F8 in 1 seconds to skip startup.nsh or any other key to continue.
Shell: fs0:
FS0:\> cd \AFUDOS
FS0:\AFUDOS> cd SNIJPM2_03162017
FS0:\AFUDOS\SNIJPM2_03162017> flash.nsh X110PU7_314

```

9. The screen above indicates that the BIOS update process is complete. When you see the screen above, unplug the AC power cable from the power supply, clear CMOS, and plug

```

Done.
[ Access Cmos Port Ex ]
<Read>
Index 0x51: 0x10

Done.
*****
*
* Program BIOS and ME (including F0T) regions...
*
*****
| AMT Firmware Update Utility v5.09.01.1917 |
| Copyright (C)2017 American Megatrends Inc. All Rights Reserved. |
*****
CPUID = 50652

Reading flash ..... done
- ME Data Size checking - ok
- FFS checksums ..... ok
- Check RomLayout ..... Ok
Erasing Boot Block ..... done
Updating Boot Block ..... done
Verifying Boot Block ..... done
_Erasing Main Block ..... 0x00132000 (0x)

```

the AC power cable in the power supply again to power on the system.

10. Press <Del> continuously to enter the BIOS Setup utility.

```

Verifying NDB Block ..... done
- Update success for FDR
- Update success for IE
- Successful Update Recovery Loader to OPRx11
- Successful Update MFSB11
- Successful Update FPR11
- Successful Update MFS, IVB1 and IVB211
- Successful Update FLOG and UTDK11
- ME Entire Image update success !!
WARNING : System must power-off to have the changes take effect!
Moving F80:\AFUDOS\SNIJPM2_03162017\Fdtv64.efi -> F80:\AFUDOS\SNIJPM2_03162017\
d1.smc
- [ok]
Moving F80:\AFUDOS\SNIJPM2_03162017\afuef1x64.efi -> F80:\AFUDOS\SNIJPM2_0316201
7\afuef1.smc
- [ok]
*****
* Please ignore this 'Shell: Cannot read from file - Device Error'
* warning message due to it does not impact flashing process.
*
*****
Deleting "afuef1.smc"
Delete successful.
FS0:\>

```

11. Press <F3> to load the default settings.
12. After loading the default settings, press <F4> to save the settings and exit the BIOS Setup utility.

## 7.6 CMOS Clear

JBT1 is used to clear CMOS, which will also clear any passwords. Instead of pins, this jumper consists of contact pads to prevent accidentally clearing the contents of CMOS.

### **To Clear CMOS**

1. First [power down](#) the system completely.
2. [Remove](#) the top cover to access the motherboard.
3. [Remove](#) the onboard battery from the motherboard.
4. Short the CMOS pads with a metal object such as a small screwdriver for at least four seconds.
5. Remove the screwdriver or shorting device.
6. Re-install the motherboard battery.
7. Replace the cover, reconnect the power cords and power on the system.

**Notes:** Clearing CMOS will also clear all passwords.

*Do not use the PW\_ON connector to clear CMOS.*



JBT1 contact pads

## 7.7 Where to Get Replacement Components

If you need replacement parts for your system, to ensure the highest level of professional service and technical support, purchase exclusively from our Supermicro Authorized Distributors/System Integrators/Resellers. A list can be found at: <http://www.supermicro.com>. Click the "Where to Buy" tab.

## 7.8 Reporting an Issue

### Technical Support Procedures

Before contacting Technical Support, please take the following steps. If your system was purchased through a distributor or reseller, please contact them for troubleshooting services. They have the best knowledge of your specific system configuration.

1. Please review the [Troubleshooting Procedures](#) in this manual and [Frequently Asked Questions](#) on our website before contacting Technical Support.
2. BIOS upgrades can be downloaded from our website. **Note:** Not all BIOS can be flashed depending on the modifications to the boot block code.
3. If you still cannot resolve the problem, include the following information when contacting us for technical support:
  - System, motherboard, and chassis model numbers and PCB revision number
  - BIOS release date/version (this can be seen on the initial display when your system first boots up)
  - System configuration

An example of a Technical Support form is posted on our [website](#). Distributors: For immediate assistance, please have your account number ready when contacting our technical support department by email.

### Returning Merchandise for Service

A receipt or copy of your invoice marked with the date of purchase is required before any warranty service will be rendered. You can obtain service by calling your vendor for a Returned Merchandise Authorization (RMA) number. When returning to the manufacturer, the RMA number should be prominently displayed on the outside of the shipping carton, and mailed prepaid or hand-carried. Shipping and handling charges will be applied for all orders that must be mailed when service is complete.

For faster service, RMA authorizations may be requested online (<http://www.supermicro.com/support/rma/>).

Whenever possible, repack the chassis in the original Supermicro carton, using the original packaging material. If these are no longer available, be sure to pack the chassis securely, using packaging material to surround the chassis so that it does not shift within the carton and become damaged during shipping.

This warranty only covers normal consumer use and does not cover damages incurred in shipping or from failure due to the alteration, misuse, abuse or improper maintenance of products.

During the warranty period, contact your distributor first for any product problems.

## Vendor Support Filing System

For issues related to Intel, use the Intel IPS filing system:

<https://www.intel.com/content/www/us/en/design/support/ips/training/welcome.html>

For issues related to Red Hat Enterprise Linux, since it is a subscription based OS, contact your account representative.

## 7.9 Feedback

Supermicro values your feedback as we strive to improve our customer experience in all facets of our business. Please email us at [techwriterteam@supermicro.com](mailto:techwriterteam@supermicro.com) to provide feedback on our manuals.

## Appendix A

# Standardized Warning Statements for AC Systems

### A.1 About Standardized Warning Statements

The following statements are industry standard warnings, provided to warn the user of situations which have the potential for bodily injury. Should you have questions or experience difficulty, contact Supermicro's Technical Support department for assistance. Only certified technicians should attempt to install or configure components.

Read this appendix in its entirety before installing or configuring components in the Supermicro chassis.

These warnings may also be found on our website at [http://www.supermicro.com/about/policies/safety\\_information.cfm](http://www.supermicro.com/about/policies/safety_information.cfm).

#### Warning Definition



**Warning!** This warning symbol means danger. You are in a situation that could cause bodily injury. Before you work on any equipment, be aware of the hazards involved with electrical circuitry and be familiar with standard practices for preventing accidents.

#### 警告の定義

この警告サインは危険を意味します。

人身事故につながる可能性がありますので、いずれの機器でも動作させる前に、電気回路に含まれる危険性に注意して、標準的な事故防止策に精通して下さい。

此警告符号代表危險。

您正处于可能受到严重伤害的工作环境中。在您使用设备开始工作之前，必须充分意识到触电的危险，并熟练掌握防止事故发生的标准工作程序。请根据每项警告结尾的声明号码找到此设备的安全性警告说明的翻译文本。

此警告符號代表危險。

您目前所處的工作環境可能讓您受傷。在您使用任何設備之前，請注意觸電的危險，並且要熟悉預防事故發生的標準工作程序。請依照每一注意事項後的號碼找到相關的翻譯說明內容。

## Warnung

## WICHTIGE SICHERHEITSHINWEISE

Dieses Warnsymbol bedeutet Gefahr. Sie befinden sich in einer Situation, die zu Verletzungen führen kann. Machen Sie sich vor der Arbeit mit Geräten mit den Gefahren elektrischer Schaltungen und den üblichen Verfahren zur Vorbeugung vor Unfällen vertraut. Suchen Sie mit der am Ende jeder Warnung angegebenen Anweisungsnummer nach der jeweiligen Übersetzung in den übersetzten Sicherheitshinweisen, die zusammen mit diesem Gerät ausgeliefert wurden.

BEWAHREN SIE DIESE HINWEISE GUT AUF.

## INSTRUCCIONES IMPORTANTES DE SEGURIDAD

Este símbolo de aviso indica peligro. Existe riesgo para su integridad física. Antes de manipular cualquier equipo, considere los riesgos de la corriente eléctrica y familiarícese con los procedimientos estándar de prevención de accidentes. Al final de cada advertencia encontrará el número que le ayudará a encontrar el texto traducido en el apartado de traducciones que acompaña a este dispositivo.

GUARDE ESTAS INSTRUCCIONES.

## IMPORTANTES INFORMATIONS DE SÉCURITÉ

Ce symbole d'avertissement indique un danger. Vous vous trouvez dans une situation pouvant entraîner des blessures ou des dommages corporels. Avant de travailler sur un équipement, soyez conscient des dangers liés aux circuits électriques et familiarisez-vous avec les procédures couramment utilisées pour éviter les accidents. Pour prendre connaissance des traductions des avertissements figurant dans les consignes de sécurité traduites qui accompagnent cet appareil, référez-vous au numéro de l'instruction situé à la fin de chaque avertissement.

CONSERVEZ CES INFORMATIONS.

## תקנון הזהרות אזהרה

הזהרות הבאות הן אזהרות על פי תקני התעשייה, על מנת להזהיר את המשתמש מפני חבלה פיזית אפשרית. במידה ויש שאלות או היתקלות בבעיה כלשהי, יש ליצור קשר עם מחלקת תמיכה טכנית של סופרמיקרו. טכנאים מוסמכים בלבד רשאים להתקין או להגדיר את הרכיבים. יש לקרוא את הנספח במלואו לפני התקנת או הגדרת הרכיבים במארזי סופרמיקרו.

اَكْ ف حالة وُكِي اَي تتسبب ف اصابة جسدهُ هذا الزهز عُ خطر! تحذُرُ .  
قبل اَي تعول على اَي هعدات، كي على علن بالوخاطز ال اُجوة عي الذوائر  
الكهزبائِة  
وكي على دراةُ بالووارسات النقااِة لو عُ وقع اَي حادث  
استخدم رِقن الب اِى الو صُص ف هاةُ كل تحذُرُ للعشر تزجوتها

안전을 위한 주의사항

경고!

이 경고 기호는 위험이 있음을 알려 줍니다. 작업자의 신체에 부상을 야기 할 수 있는 상태에 있게 됩니다. 모든 장비에 대한 작업을 수행하기 전에 전기회로와 관련된 위험요소들을 확인하시고 사전에 사고를 방지할 수 있도록 표준 작업절차를 준수해 주시기 바랍니다.

해당 번역문을 찾기 위해 각 경고의 마지막 부분에 제공된 경고문 번호를 참조하십시오

## BELANGRIJKE VEILIGHEIDSINSTRUCTIES

Dit waarschuwings symbool betekent gevaar. U verkeert in een situatie die lichamelijk letsel kan veroorzaken. Voordat u aan enige apparatuur gaat werken, dient u zich bewust te zijn van de bij een elektrische installatie betrokken risico's en dient u op de hoogte te zijn van de standaard procedures om ongelukken te voorkomen. Gebruik de nummers aan het eind van elke waarschuwing om deze te herleiden naar de desbetreffende locatie.

BEWAAR DEZE INSTRUCTIES

## Installation Instructions



**Warning!** Read the installation instructions before connecting the system to the power source.

設置手順書

システムを電源に接続する前に、設置手順書をお読み下さい。

警告

将此系统连接电源前,请先阅读安装说明。

警告

將系統與電源連接前，請先閱讀安裝說明。

Warnung

Vor dem Anschließen des Systems an die Stromquelle die Installationsanweisungen lesen.

¡Advertencia!

Lea las instrucciones de instalación antes de conectar el sistema a la red de alimentación.

Attention

Avant de brancher le système sur la source d'alimentation, consulter les directives d'installation.

יש לקרוא את הוראות התקנה לפני חיבור המערכת למקור מתח.

اقر إرشادات التركيب قبل توصيل النظام إلى مصدر للطاقة

시스템을 전원에 연결하기 전에 설치 안내를 읽어주십시오.

Waarschuwing

Raadpleeg de installatie-instructies voordat u het systeem op de voedingsbron aansluit.

## Circuit Breaker



**Warning!** This product relies on the building's installation for short-circuit (overcurrent) protection. Ensure that the protective device is rated not greater than: 250 V, 20 A.

サーキット・ブレーカー

この製品は、短絡(過電流)保護装置がある建物での設置を前提としています。

保護装置の定格が250 V、20 Aを超えないことを確認下さい。

警告

此产品的短路(过载电流)保护由建筑物的供电系统提供,确保短路保护设备的额定电流不大于250V,20A。

警告

此產品的短路(過載電流)保護由建築物的供電系統提供,確保短路保護設備的額定電流不大於250V,20A。

### Warnung

Dieses Produkt ist darauf angewiesen, dass im Gebäude ein Kurzschluss- bzw. Überstromschutz installiert ist. Stellen Sie sicher, dass der Nennwert der Schutzvorrichtung nicht mehr als: 250 V, 20 A beträgt.

### ¡Advertencia!

Este equipo utiliza el sistema de protección contra cortocircuitos (o sobrecorrientes) del edificio. Asegúrese de que el dispositivo de protección no sea superior a: 250 V, 20 A.

### Attention

Pour ce qui est de la protection contre les courts-circuits (surtension), ce produit dépend de l'installation électrique du local. Vérifiez que le courant nominal du dispositif de protection n'est pas supérieur à :250 V, 20 A.

מוצר זה מסתמך על הגנה המותקנת במבנים למניעת קצר חשמלי. יש לוודא כי המכשיר המגן מפני הקצר החשמלי הוא לא יותר מ-250VDC, 20A

هذا المنتج يعتمد على معدات الحماية مه الدوائر القصيرة التي تم تثبيتها في المبنى  
تأكد من أن تقييم الجهاز الوقائي ليس أكثر من : 20A, 250V

### 경고!

이 제품은 전원의 단락(과전류)방지에 대해서 전적으로 건물의 관련 설비에 의존합니다. 보호장치의 정격이 반드시 250V(볼트), 20A(암페어)를 초과하지 않도록 해야 합니다.

### Waarschuwing

Dit product is afhankelijk van de kortsluitbeveiliging (overspanning) van uw elektrische installatie. Controleer of het beveiligde apparaat niet groter gedimensioneerd is dan 250V, 20A.

## Power Disconnection Warning



**Warning!** The system must be disconnected from all sources of power and the power cord removed from the power supply module(s) before accessing the chassis interior to install or remove system components.

### 電源切斷の警告

システムコンポーネントの取り付けまたは取り外しのために、シャーシ内部にアクセスするには、システムの電源はすべてのソースから切斷され、電源コードは電源モジュールから取り外す必要があります。

### 警告

在你打开机箱并安装或移除内部器件前,必须将系统完全断电,并移除电源线。

### 警告

在您打開機殼安裝或移除內部元件前，必須將系統完全斷電，並移除電源線。

### Warnung

Das System muss von allen Quellen der Energie und vom Netzanschlusskabel getrennt sein, das von den Spg.Versorgungsteilmodulen entfernt wird, bevor es auf den Chassisinnenraum zurückgreift, um Systemsbestandteile anzubringen oder zu entfernen.

### ¡Advertencia!

El sistema debe ser disconnected de todas las fuentes de energía y del cable eléctrico quitado de los módulos de fuente de alimentación antes de tener acceso el interior del chasis para instalar o para quitar componentes de sistema.

### Attention

Le système doit être débranché de toutes les sources de puissance ainsi que de son cordon d'alimentation secteur avant d'accéder à l'intérieur du chasis pour installer ou enlever des composants de système.

אזהרה מפני ניתוק חשמלי

אזהרה!

יש לנתק את המערכת מכל מקורות החשמל ויש להסיר את כבל החשמלי מהספק לפני גישה לחלק הפנימי של המארז לצורך התקנת או הסרת רכיבים.

يجب فصل انظاؤ من جميع مصادر انطاقت وإزانت سهك انكهرباء من وحدة امداد  
انطاقت قيم  
انصل إلى امناطق انداخهيت نههيكم نتشيج أو إزانت مكناث الجهاز

경고!

시스템에 부품들을 장착하거나 제거하기 위해서는 새시 내부에 접근하기 전에 반드시 전원 공급장치로부터 연결되어있는 모든 전원과 전기코드를 분리해주어야 합니다.

Waarschuwing

Voordat u toegang neemt tot het binnenwerk van de behuizing voor het installeren of verwijderen van systeem onderdelen, dient u alle spanningsbronnen en alle stroomkabels aangesloten op de voeding(en) van de behuizing te verwijderen

## Equipment Installation



**Warning!** Only trained and qualified personnel should be allowed to install, replace, or service this equipment.

機器の設置

トレーニングを受け認定された人だけがこの装置の設置、交換、またはサービスを許可されてい  
ます。

警告

只有经过培训且具有资格的人员才能进行此设备的安装、更换和维修。

警告

只有經過受訓且具資格人員才可安裝、更換與維修此設備。

Warnung

Das Installieren, Ersetzen oder Bedienen dieser Ausrüstung sollte nur geschultem, qualifiziertem Personal gestattet werden.

¡Advertencia!

Solamente el personal calificado debe instalar, reemplazar o utilizar este equipo.

**Attention**

Il est vivement recommandé de confier l'installation, le remplacement et la maintenance de ces équipements à des personnels qualifiés et expérimentés.

אזהרה!

צוות מוסמך בלבד רשאי להתקין, להחליף את הציוד או לתת שירות עבור הציוד.

والمدربيه لتزكيب واستبدال أو خدمة هذا الجهاز يجب أن يسمح فقط للمظفيه المؤهليه

경고!

훈련을 받고 공인된 기술자만이 이 장비의 설치, 교체 또는 서비스를 수행할 수 있습니다.

**Waarschuwing**

Deze apparatuur mag alleen worden geïnstalleerd, vervangen of hersteld door geschoold en gekwalificeerd personeel.

**Restricted Area**

**Warning!** This unit is intended for installation in restricted access areas. A restricted access area can be accessed only through the use of a special tool, lock and key, or other means of security. (This warning does not apply to workstations).

**アクセス制限区域**

このユニットは、アクセス制限区域に設置されることを想定しています。

アクセス制限区域は、特別なツール、鍵と錠前、その他のセキュリティの手段を用いてのみ出入りが可能です。

**警告**

此部件应安装在限制进出的场所，限制进出的场所指只能通过使用特殊工具、锁和钥匙或其它安全手段进出的场所。

**警告**

此装置僅限安裝於進出管制區域，進出管制區域係指僅能以特殊工具、鎖頭及鑰匙或其他安全方式才能進入的區域。

### Warnung

Diese Einheit ist zur Installation in Bereichen mit beschränktem Zutritt vorgesehen. Der Zutritt zu derartigen Bereichen ist nur mit einem Spezialwerkzeug, Schloss und Schlüssel oder einer sonstigen Sicherheitsvorkehrung möglich.

### ¡Advertencia!

Esta unidad ha sido diseñada para instalación en áreas de acceso restringido. Sólo puede obtenerse acceso a una de estas áreas mediante la utilización de una herramienta especial, cerradura con llave u otro medio de seguridad.

### Attention

Cet appareil doit être installée dans des zones d'accès réservés. L'accès à une zone d'accès réservé n'est possible qu'en utilisant un outil spécial, un mécanisme de verrouillage et une clé, ou tout autre moyen de sécurité.

אזור עם גישה מוגבלת

אזהרה!

יש להתקין את היחידה באזורים שיש בהם הגבלת גישה. הגישה ניתנת בעזרת 'כלי אבטחה בלבד' (מפתח, מנעול וכד.).

تخصيص هذه انحدة نترك بُها ف مناطق محظورة تم .  
ممكن اننصل إن منطقت محظورة فقط من خلال استخذاو أداة خاصت  
أو أ وس هُت أخري نلالأمما ققم ومفتاح

### 경고!

이 장치는 접근이 제한된 구역에 설치하도록 되어있습니다. 특수도구, 잠금 장치 및 키, 또는 기타 보안 수단을 통해서만 접근 제한 구역에 들어갈 수 있습니다.

### Waarschuwing

Dit apparaat is bedoeld voor installatie in gebieden met een beperkte toegang. Toegang tot dergelijke gebieden kunnen alleen verkregen worden door gebruik te maken van speciaal gereedschap, slot en sleutel of andere veiligheidsmaatregelen.

## Battery Handling



**Warning!** There is the danger of explosion if the battery is replaced incorrectly. Replace the battery only with the same or equivalent type recommended by the manufacturer. Dispose of used batteries according to the manufacturer's instructions

### 電池の取り扱い

電池交換が正しく行われなかった場合、破裂の危険性があります。交換する電池はメーカーが推奨する型、または同等のものを使用下さい。使用済電池は製造元の指示に従って処分して下さい。

### 警告

電池更換不當會有爆炸危險。請只使用同類電池或制造商推薦的功能相當的電池更換原有電池。請按製造商的說明處理廢舊電池。

### 警告

電池更換不當會有爆炸危險。請使用製造商建議之相同或功能相當的電池更換原有電池。請按照製造商的說明指示處理廢棄舊電池。

### Warnung

Bei Einsetzen einer falschen Batterie besteht Explosionsgefahr. Ersetzen Sie die Batterie nur durch den gleichen oder vom Hersteller empfohlenen Batterietyp. Entsorgen Sie die benutzten Batterien nach den Anweisungen des Herstellers.

### Attention

Danger d'explosion si la pile n'est pas remplacée correctement. Ne la remplacer que par une pile de type semblable ou équivalent, recommandée par le fabricant. Jeter les piles usagées conformément aux instructions du fabricant.

### ¡Advertencia!

Existe peligro de explosión si la batería se reemplaza de manera incorrecta. Reemplazar la batería exclusivamente con el mismo tipo o el equivalente recomendado por el fabricante. Desechar las baterías gastadas según las instrucciones del fabricante.

אזהרה!

קיימת סכנת פיצוץ של הסוללה במידה והוחלפה בדרך לא תקינה. יש להחליף את הסוללה בסוג התואם מחברת יצרן מומלצת. סילוק הסוללות המשומשות יש לבצע לפי הוראות היצרן.

هناك خطر من انفجار في حالة اسحبذال البطارية بطريقة غير صحيحة فعليل  
اسحبذال البطارية  
فقط بنفس النوع أو ما يعادلها مما أوصت به الشركة المصنعة  
جخلص من البطاريات المسحمة وفقا لعمليات الشركة الصانعة

경고!

배터리가 올바르게 교체되지 않으면 폭발의 위험이 있습니다. 기존 배터리와 동일하거나 제조사에서 권장하는 동등한 종류의 배터리로만 교체해야 합니다. 제조사의 안내에 따라 사용된 배터리를 처리하여 주십시오.

Waarschuwing

Er is ontplofingsgevaar indien de batterij verkeerd vervangen wordt. Vervang de batterij slechts met hetzelfde of een equivalent type die door de fabrikant aanbevolen wordt. Gebruikte batterijen dienen overeenkomstig fabrieksvoorschriften afgevoerd te worden.

## Redundant Power Supplies



**Warning!** This unit might have more than one power supply connection. All connections must be removed to de-energize the unit.

冗長電源装置

このユニットは複数の電源装置が接続されている場合があります。

ユニットの電源を切るためには、すべての接続を取り外さなければなりません。

警告

此部件连接的电源可能不止一个，必须将所有电源断开才能停止给该部件供电。

警告

此装置连接的电源可能不只一个，必须切断所有电源才能停止对该装置的供电。

Warnung

Dieses Gerät kann mehr als eine Stromzufuhr haben. Um sicherzustellen, dass der Einheit kein Strom zugeführt wird, müssen alle Verbindungen entfernt werden.

¡Advertencia!

Puede que esta unidad tenga más de una conexión para fuentes de alimentación. Para cortar por completo el suministro de energía, deben desconectarse todas las conexiones.

Attention

Cette unité peut avoir plus d'une connexion d'alimentation. Pour supprimer toute tension et tout courant électrique de l'unité, toutes les connexions d'alimentation doivent être débranchées.

אם קיים יותר מספק אחד

אזהרה!

ליחידה יש יותר מחיבור אחד של ספק. יש להסיר את כל החיבורים על מנת לרוקן את היחידה.

قد يكون لهذا الجهاز عدة اتصالات بوحدات امداد الطاقة .

يجب إزالة كافة الاتصالات لعسل الوحدة عن الكهرباء

경고!

이 장치에는 한 개 이상의 전원 공급 단자가 연결되어 있을 수 있습니다. 이 장치에 전원을 차단하기 위해서는 모든 연결 단자를 제거해야만 합니다.

Waarschuwing

Deze eenheid kan meer dan één stroomtoevoeraansluiting bevatten. Alle aansluitingen dienen verwijderd te worden om het apparaat stroomloos te maken.

## Backplane Voltage



**Warning!** Hazardous voltage or energy is present on the backplane when the system is operating. Use caution when servicing.

### バックプレーンの電圧

システムの稼働中は危険な電圧または電力が、バックプレーン上にかかっています。

修理する際には注意ください。

### 警告

当システム正在进行时，背板上有很危险的电压或能量，进行维修时务必小心。

### 警告

當系統正在進行時，背板上危險的電壓或能量，進行維修時務必小心。

### Warnung

Wenn das System in Betrieb ist, treten auf der Rückwandplatine gefährliche Spannungen oder Energien auf. Vorsicht bei der Wartung.

### ¡Advertencia!

Cuando el sistema está en funcionamiento, el voltaje del plano trasero es peligroso. Tenga cuidado cuando lo revise.

### Attention

Lorsque le système est en fonctionnement, des tensions électriques circulent sur le fond de panier. Prendre des précautions lors de la maintenance.

מתח בפנל האחורי

אזהרה!

קיימת סכנת מתח בפנל האחורי בזמן תפעול המערכת. יש להיזהר במהלך העבודה.

هناك خطر من التيار الكهربائي أو الطاقة المتجددة على اللوحة  
عندما يكون النظام يعمل كه حذرا عند خدمة هذا الجهاز

경고!

시스템이 동작 중일 때 후면판 (Backplane)에는 위험한 전압이나 에너지가 발생 합니다.  
서비스 작업 시 주의하십시오.

Waarschuwing

Een gevaarlijke spanning of energie is aanwezig op de backplane wanneer het systeem in gebruik is. Voorzichtigheid is geboden tijdens het onderhoud.

## Comply with Local and National Electrical Codes



**Warning!** Installation of the equipment must comply with local and national electrical codes.

地方および国の電気規格に準拠

機器の取り付けはその地方および国の電気規格に準拠する必要があります。

警告

设备安装必须符合本地与本国电气法规。

警告

設備安裝必須符合本地與本國電氣法規。

Warnung

Die Installation der Geräte muss den Sicherheitsstandards entsprechen.

¡Advertencia!

La instalación del equipo debe cumplir con las normas de electricidad locales y nacionales.

Attention

L'équipement doit être installé conformément aux normes électriques nationales et locales.

תיאום חוקי החשמל הארצי

אזהרה!

התקנת הציוד חייבת להיות תואמת לחוקי החשמל המקומיים והארציים.

تركيب المعدات الكهربائية يجب أن يمتثل للقوايه المحلية والبطية المتعلقة

بالكهرباء

경고!

현 지역 및 국가의 전기 규정에 따라 장비를 설치해야 합니다.

Waarschuwing

Bij installatie van de apparatuur moet worden voldaan aan de lokale en nationale elektriciteitsvoorschriften.

## Product Disposal



**Warning!** Ultimate disposal of this product should be handled according to all national laws and regulations.

製品の廃棄

この製品を廃棄処分する場合、国の関係する全ての法律・条例に従い処理する必要があります。

警告

本产品的废弃处理应根据所有国家的法律和规章进行。

警告

本產品的廢棄處理應根據所有國家的法律和規章進行。

Warnung

Die Entsorgung dieses Produkts sollte gemäß allen Bestimmungen und Gesetzen des Landes erfolgen.

¡Advertencia!

Al deshacerse por completo de este producto debe seguir todas las leyes y reglamentos nacionales.

## Attention

La mise au rebut ou le recyclage de ce produit sont généralement soumis à des lois et/ou directives de respect de l'environnement. Renseignez-vous auprès de l'organisme compétent.

סילוק המוצר

אזהרה!

סילוק סופי של מוצר זה חייב להיות בהתאם להנחיות וחוקי המדינה.

التخلص النهائي من هذا المنتج ينبغي التعامل معه وفقا لجميع القوانين واللوائح الوطنية عند

## 경고!

이 제품은 해당 국가의 관련 법규 및 규정에 따라 폐기되어야 합니다.

## Waarschuwing

De uiteindelijke verwijdering van dit product dient te geschieden in overeenstemming met alle nationale wetten en reglementen.

## Hot Swap Fan Warning



**Warning!** Hazardous moving parts. Keep away from moving fan blades. The fans might still be turning when you remove the fan assembly from the chassis. Keep fingers, screwdrivers, and other objects away from the openings in the fan assembly's housing.

## ファン・ホットスワップの警告

警告!回転部品に注意。運転中は回転部(羽根)に触れないでください。シャーシから冷却ファン装置を取り外した際、ファンがまだ回転している可能性があります。ファンの開口部に、指、ドライバー、およびその他のものを近づけないで下さい。

## 警告!

警告! 危險的可移動性零件。請務必與轉動的风扇叶片保持距離。當您從機架移除風扇裝置，風扇可能仍在轉動。小心不要將手指、螺絲起子和其他物品太靠近風扇

## 警告

危險的可移動性零件。請務必與轉動的风扇叶片保持距離。當您從機架移除風扇裝置，風扇可能仍在轉動。小心不要將手指、螺絲起子和其他物品太靠近風扇。

### Warnung

Gefährlich Bewegende Teile. Von den bewegenden Lüfterblätter fern halten. Die Lüfter drehen sich u. U. noch, wenn die Lüfterbaugruppe aus dem Chassis genommen wird. Halten Sie Finger, Schraubendreher und andere Gegenstände von den Öffnungen des Lüftergehäuses entfernt.

### ¡Advertencia!

Riesgo de piezas móviles. Mantener alejado de las aspas del ventilador. Los ventiladores podran dar vuelta cuando usted quite el montaje del ventilador del chasis. Mantenga los dedos, los destornilladores y todos los objetos lejos de las aberturas del ventilador

### Attention

Pieces mobiles dangereuses. Se tenir a l'écart des lames du ventilateur Il est possible que les ventilateurs soient toujours en rotation lorsque vous retirerez le bloc ventilateur du châssis. Prenez garde à ce que doigts, tournevis et autres objets soient éloignés du logement du bloc ventilateur.

### אזהרה!

חלקים נעים מסוכנים. התרחק מלהבי המאוורר בפעולה כאשר מסירים את חלקי המאוורר מהמארז, יתכן והמאווררים עדיין עובדים. יש להרחיק למרחק בטוח את האצבעות וכלי עבודה שונים מהפתחים בתוך המאוורר

تحذير! أجزاء متحركة خطيرة. ابتعد عن شفرات المروحة المتحركة. من الممكن أن المراوح لا تزال تدور عند إزالة كتلة المروحة من الهيكل يجب إبقاء الأصابع ومفكات البراغي وغيرها من الأشياء بعيدا عن الفتحات في كتلة المروحة

### 경고!

움직이는 위험한 부품. 회전하는 송풍 날개에 접근하지 마세요. 새시로부터 팬 조립품을 제거할 때 팬은 여전히 회전하고 있을 수 있습니다. 팬 조립품 외관의 열려있는 부분들로부터 손가락 및 스크류드라이버, 다른 물체들이 가까이 하지 않도록 배치해 주십시오.

### Waarschuwing

Gevaarlijk bewegende onderdelen. Houd voldoende afstand tot de bewegende ventilatorbladen. Het is mogelijk dat de ventilator nog draait tijdens het verwijderen van het ventilatorsamenstel uit het chassis. Houd uw vingers, schroevendraaiers en eventuele andere voorwerpen uit de buurt van de openingen in de ventilatorbehuizing.

## Power Cable and AC Adapter



**Warning!** When installing the product, use the provided or designated connection cables, power cables and AC adaptors. Using any other cables and adaptors could cause a malfunction or a fire. Electrical Appliance and Material Safety Law prohibits the use of UL or CSA -certified cables (that have UL/CSA shown on the code) for any other electrical devices than products designated by Supermicro only.

### 電源コードとACアダプター

製品を設置する場合、提供または指定および購入された接続ケーブル、電源コードとACアダプターを、該当する地域の条例や安全基準に適合するコードサイズやプラグと共に使用下さい。他のケーブルやアダプタを使用すると故障や火災の原因になることがあります。

電気用品安全法は、ULまたはCSA認定のケーブル(UL/CSAマークがコードに表記)を Supermicro が指定する製品以外に使用することを禁止しています。

### 警告

安装此产品时,请使用本身提供的或指定的或采购的连接线,电源线和电源适配器。包含遵照当地法规和安全要求的合规的电源线尺寸和插头。使用其它线材或适配器可能会引起故障或火灾。除了Supermicro所指定的产品,电气用品和材料安全法律规定禁止使用未经UL或CSA认证的线材。(线材上会显示UL/CSA符号)。

### 警告

安裝此產品時,請使用本身提供的或指定的或採購的連接線,電源線和電源適配器。包含遵照當地法規和安全要求的合規的電源線尺寸和插頭。使用其它線材或適配器可能會引起故障或火災。除了Supermicro所指定的產品,電氣用品和材料安全法律規定禁止使用未經UL或CSA認證的線材。(線材上會顯示UL/CSA符號)。

### Warnung

Nutzen Sie beim Installieren des Produkts ausschließlich die von uns zur Verfügung gestellten Verbindungskabeln, Stromkabeln und/oder Adapter, die Ihre örtlichen Sicherheitsstandards einhalten. Der Gebrauch von anderen Kabeln und Adapter können Fehlfunktionen oder Feuer verursachen. Die Richtlinien untersagen das Nutzen von UL oder CAS zertifizierten Kabeln (mit UL/CSA gekennzeichnet), an Geräten oder Produkten die nicht mit Supermicro gekennzeichnet sind.

### ¡Advertencia!

Cuando instale el producto, utilice la conexión provista o designada o procure cables, Cables de alimentación y adaptadores de CA que cumplan con los códigos locales y los requisitos de seguridad, incluyendo el tamaño adecuado del cable y el enchufe. El uso de otros cables y adaptadores podría causar un mal funcionamiento o un incendio. La Ley de Seguridad de Aparatos Eléctricos y de Materiales prohíbe El uso de cables certificados por UL o CSA (que tienen el certificado UL / CSA en el código) para cualquier otros dispositivos eléctricos que los productos designados únicamente por Supermicro.

### Attention

Lors de l'installation du produit, utilisez les cables de connection fournis ou désigné ou achetez des cables, cables de puissance et adaptateurs respectant les normes locales et les conditions de securite y compris les tailles de cables et les prises electriques appropries. L'utilisation d'autres cables et adaptateurs peut provoquer un dysfonctionnement ou un incendie. Appareils électroménagers et la Loi sur la Sécurité Matériel interdit l'utilisation de câbles certifiés- UL ou CSA (qui ont UL ou CSA indiqué sur le code) pour tous les autres appareils électriques sauf les produits désignés par Supermicro seulement.

AC ימאתמו מיילמשח מילבכ

!הרהזא

ךרוצל ומאתוה וא ושכרנ רשא AC מימאתמו מיקפס, מילבכב שמתשהל שי, רצומה תא מיניקתמ רשאכ לכב שומיש . עקתהו לבכה לש הנוכח הדימ ללוכ, תוימוקמה תוחיטבה תושירדל ומאתוה רשאו, הנקתהה למשחה ירישכמב שומישה יקוחל מאתהב. ילמשח רצק וא הלקתל מורגל לולע, רחא גוסמ מאתמ וא לבכ לש דוק מהילע עיפומ רשאכ) UL ב- או CSA ב- מיכמומה מילבכב שמתשהל רוסיא מייק, תוחיטבה יקוחו דבלב Supermicro י"ע מאתוה רשא רצומב קר אלא, רחא ילמשח רצומ לכ רובע (UL/CSA)

תאלבאלא אארשב מץ וא אדדחמלא וא ארפוטמלא תאליטוטלא מאדחטסאב מץ, אגתנמלא בייקרת דנע לכלז יפ אמב אילחמלא אמאלסלא תאבלטתמו נינאוץב מאזתלאלא אמ דדרתמלא ראיטלא תאלוחמו אילברמלא קיירח וא לטע יפ בבסטטי דץ ירשא תאלוחמו תאלבאלא יא מאדחטסא. מילסלא סבאלאו לטומולא מץח CSA וא UL לבק נמ אדמתמלא תאלבאלא מאדחטסא תאדמלאו אילברמלא אזהאלל אמאלסלא נונאק רזחיי Supermicro לבק נמ אדדחמלאו אילברמלא תאגתנמלא רייג ירשא תאדמלא יא אמ (UL/CSA) אמאלע למחתיטלאו

### 전원 케이블 및 AC 어댑터

경고! 제품을 설치할 때 현지 코드 및 적절한 굵기의 코드와 플러그를 포함한 안전 요구 사항을 준수하여 제공되거나 지정된 연결 혹은 구매 케이블, 전원 케이블 및 AC 어댑터를 사용하십시오.

다른 케이블이나 어댑터를 사용하면 오작동이나 화재가 발생할 수 있습니다. 전기 용품 안전법은 UL 또는 CSA 인증 케이블 (코드에 UL / CSA가 표시된 케이블)을 Supermicro가 지정한 제품 이외의 전기 장치에 사용하는 것을 금지합니다.

### Stroomkabel en AC-Adapter

Waarschuwing! Bij het aansluiten van het Product uitsluitend gebruik maken van de geleverde Kabels of een andere geschikte aan te schaffen Aansluitmethode, deze moet altijd voldoen aan de lokale voorschriften en veiligheidsnormen, inclusief de juiste kabeldikte en stekker. Het gebruik van niet geschikte Kabels en/of Adapters kan een storing of brand veroorzaken. Wetgeving voor Elektrische apparatuur en Materiaalveiligheid verbied het gebruik van UL of CSA -gecertificeerde Kabels (met UL/CSA in de code) voor elke andere toepassing dan de door Supermicro hiervoor beoogde Producten.

# Appendix B

## System Specifications

### Processors

Single Intel® Atom P5000 series processor, with up to 24 cores at a 83W TDP

### Chipset

System on Chip

### BIOS

32 Mb AMI UEFI BIOS®

UEFI 2.7, ACPI 6.0 or later, and SMBIOS 3.0 or later

### Memory

Supports up to 256GB of RDIMM or 64GB of Non-ECC/ECC UDIMM DDR4 memory in four slots

SYS-110A-16C-RN10SP: DDR4 2667MT/s, SYS-110A-24C-RN10SP: DDR4 2933MT/s

### Storage Drives

Two 2.5" hot-swap SATA/SAS drive bays

One M.2 M-Key 2242/2280/22110 (PCIe 2.0 x4/SATA 2.0/USB 2.0)

One M.2 B-Key 2242/3042/2280 (PCIe 2.0 x2/SATA 2.0/USB 3.0)

One M.2 E-Key 2230 (PCIe 2.0 x1/USB 2.0)

### PCI Expansion Slots

One PCIe 3.0 x8

### Input/Output

One VGA port

Two rear USB 3.0 ports

Eight RJ45 1GbE LAN ports

Two 25G SFP28 LAN ports

One RJ45 dedicated IPMI LAN port

### Motherboard

A3SSV-16C/24C-SPLN10F; 9" x 7.25" (22.86cm x 18.42cm)

### Chassis

CSE-506TS-R301P; 1U rackmount; 6.1" (H) x 25.8" (W) x 18.3" (D)

### System Cooling

Three internal fixed 40 x 28mm fans

**Power Supply**

SYS-110A-16C-RN10SP; Model: PWS-301P-1R, 300 W redundant module, 80Plus Gold level  
 300W: 100-240Vac / 68.5A / 50-60Hz  
 Rated Output Power: +12 V  
 Max: 25A / Min: 0A  
 Standby +5Vsb: Max: 3A / Min: 0A

SYS-110A-24C-RN10SP; Model: PWS-301P-1R, 300 W redundant module, 80Plus Gold level  
 300W: 100-240Vac / 68.5A / 50-60Hz  
 Rated Output Power: +12 V  
 Max: 25A / Min: 0A  
 Standby +5Vsb: Max: 3A / Min: 0A

**Operating Environment**

Operating Temperature: 0°C ~ 40°C (32°F ~ 104°F)  
 Non-operating Temperature: -40°C ~ 70°C (-40°F ~ 158°F)  
 Operating Relative Humidity: 8% to 90% (non-condensing)  
 Non-operating Relative Humidity: 5% to 95% (non-condensing)

**Regulatory Compliance**

FCC, ICES, CE, VCCI, RCM, UKCA, NRTL, CB

**Applied Directives, Standards**

EMC/EMI: 2014/30/EU (EMC Directive)  
 Electromagnetic Compatibility Regulations 2016  
 FCC Part 15 Subpart B  
 ICES-003  
 VCCI-CISPR 32  
 AS/NZS CISPR 32  
 BS/EN55032  
 BS/EN55035  
 CISPR 32/CISPR 35  
 BS/EN 61000-3-2  
 BS/EN 61000-3-3  
 BS/EN 61000-4-2  
 BS/EN 61000-4-3  
 BS/EN 61000-4-4  
 BS/EN 61000-4-5  
 BS/EN 61000-4-6  
 BS/EN 61000-4-8  
 BS/EN 61000-4-11

Green Environment:  
 2011/65/EU (RoHS Directive)  
 EC 1907/2006 (REACH)  
 2012/19/EU (WEEE Directive)  
 California Proposition 65

Product Safety: 2014/35/EU (LVD Directive)  
 Electrical Equipment (Safety) Regulations 2016  
 UL/CSA, 62368-1 (USA and Canada)  
 BS/IEC/EN, 62368-1

### Perchlorate Warning

California Best Management Practices Regulations for Perchlorate Materials: This Perchlorate warning applies only to products containing CR (Manganese Dioxide) Lithium coin cells. "Perchlorate Material-special handling may apply. See [www.dtsc.ca.gov/hazardouswaste/perchlorate](http://www.dtsc.ca.gov/hazardouswaste/perchlorate)"

この装置は、クラスA機器です。この装置を住宅環境で使用すると電波妨害を引き起こすことがあります。この場合には使用者が適切な対策を講ずるよう要求されることがあります。

VCCI - A

## BSMI/RoHS

## 限用物質含有情況標示聲明書

Declaration of the Presence Condition of the Restricted Substances Marking

設備名稱：伺服器/ Server Equipment name						
型號（型式）：506-R3A3 (系列型號: SYS-110A-16C-RN10SP, SYS-110A-24C-RN10SP) Type designation (Type)						
單元 Unit	限用物質及其化學符號 Restricted substances and its chemical symbols					
	鉛Lead (Pb)	汞Mercury (Hg)	鎘Cadmium (Cd)	六價鉻 Hexavalent chromium (Cr <sup>+6</sup> )	多溴聯苯 Polybrominated biphenyls (PBB)	多溴二苯醚 Polybrominated diphenyl ethers (PBDE)
機殼 (Chassis)	○	○	○	○	○	○
機殼風扇 (Chassis Fan)	—	○	○	○	○	○
線材 (Cable)	○	○	○	○	○	○
主機板 (Motherboard)	—	○	○	○	○	○
電源供應器 (Power Supply)	—	○	○	○	○	○
硬碟 (SSD)	—	○	○	○	○	○
電源背板 (PDB)	—	○	○	○	○	○
附加卡 (Add on Card)	—	○	○	○	○	○
備考1. “超出0.1 wt %” 及 “超出0.01 wt %” 係指限用物質之百分比含量超出百分比含量基準值。 Note 1: “Exceeding 0.1 wt %” and “exceeding 0.01 wt %” indicate that the percentage content of the restricted substance exceeds the reference percentage value of presence condition.						
備考2. “○” 係指該項限用物質之百分比含量未超出百分比含量基準值。 Note 2: “○” indicates that the percentage content of the restricted substance does not exceed the percentage of reference value of presence.						
備考3. “—” 係指該項限用物質為排除項目。 Note 3: The “—” indicates that the restricted substance corresponds to the exemption.						

警告:

為避免電磁干擾,本產品不應該安裝或使用於住宅環境。

輸入額定:

100-240V ~, 60-50Hz, 5-3A (x2)

\*使用者不能任意拆除或替換內部配備

\*報驗義務人之姓名或名稱：美超微電腦股份有限公司

\*報驗義務人之地址：新北市中和區建一路 150 號 3 樓