



SUPERSERVER[®]
SYS-110C-FHN4T



USER'S MANUAL

Revision 1.1

The information in this User's Manual has been carefully reviewed and is believed to be accurate. The vendor assumes no responsibility for any inaccuracies that may be contained in this document, and makes no commitment to update or to keep current the information in this manual, or to notify any person or organization of the updates. Please Note: For the most up-to-date version of this manual, please see our website at www.supermicro.com.

Super Micro Computer, Inc. ("Supermicro") reserves the right to make changes to the product described in this manual at any time and without notice. This product, including software and documentation, is the property of Supermicro and/or its licensors, and is supplied only under a license. Any use or reproduction of this product is not allowed, except as expressly permitted by the terms of said license.

IN NO EVENT WILL Super Micro Computer, Inc. BE LIABLE FOR DIRECT, INDIRECT, SPECIAL, INCIDENTAL, SPECULATIVE OR CONSEQUENTIAL DAMAGES ARISING FROM THE USE OR INABILITY TO USE THIS PRODUCT OR DOCUMENTATION, EVEN IF ADVISED OF THE POSSIBILITY OF SUCH DAMAGES. IN PARTICULAR, SUPER MICRO COMPUTER, INC. SHALL NOT HAVE LIABILITY FOR ANY HARDWARE, SOFTWARE, OR DATA STORED OR USED WITH THE PRODUCT, INCLUDING THE COSTS OF REPAIRING, REPLACING, INTEGRATING, INSTALLING OR RECOVERING SUCH HARDWARE, SOFTWARE, OR DATA.

Any disputes arising between manufacturer and customer shall be governed by the laws of Santa Clara County in the State of California, USA. The State of California, County of Santa Clara shall be the exclusive venue for the resolution of any such disputes. Supermicro's total liability for all claims will not exceed the price paid for the hardware product.

FCC Statement: This equipment has been tested and found to comply with the limits for a Class A or Class B digital device pursuant to Part 15 of the FCC Rules. These limits are designed to provide reasonable protection against harmful interference when the equipment is operated in industrial environment for Class A device or in residential environment for Class B device. This equipment generates, uses, and can radiate radio frequency energy and, if not installed and used in accordance with the manufacturer's instruction manual, may cause harmful interference with radio communications. Operation of this equipment in a residential area is likely to cause harmful interference, in which case you will be required to correct the interference at your own expense.

California Best Management Practices Regulations for Perchlorate Materials: This Perchlorate warning applies only to products containing CR (Manganese Dioxide) Lithium coin cells. "Perchlorate Material-special handling may apply. See www.dtsc.ca.gov/hazardouswaste/perchlorate".



WARNING: This product can expose you to chemicals including lead, known to the State of California to cause cancer and birth defects or other reproductive harm. For more information, go to www.P65Warnings.ca.gov.

The products sold by Supermicro are not intended for and will not be used in life support systems, medical equipment, nuclear facilities or systems, aircraft, aircraft devices, aircraft/emergency communication devices or other critical systems whose failure to perform be reasonably expected to result in significant injury or loss of life or catastrophic property damage. Accordingly, Supermicro disclaims any and all liability, and should buyer use or sell such products for use in such ultra-hazardous applications, it does so entirely at its own risk. Furthermore, buyer agrees to fully indemnify, defend and hold Supermicro harmless for and against any and all claims, demands, actions, litigation, and proceedings of any kind arising out of or related to such ultra-hazardous use or sale.

Manual Revision 1.1

Release Date: July 15, 2025

Unless you request and receive written permission from Super Micro Computer, Inc., you may not copy any part of this document. Information in this document is subject to change without notice. Other products and companies referred to herein are trademarks or registered trademarks of their respective companies or mark holders.

Copyright © 2025 by Super Micro Computer, Inc.
All rights reserved.

Printed in the United States of America

Preface

About this Manual

This manual is written for professional system integrators and PC technicians. It provides information for the installation and use of the server. Installation and maintenance should be performed by certified service technicians only.

Please refer to the SYS-110C-FHN4T server specifications page on our website for updates on supported memory, processors, and operating systems (<http://www.supermicro.com>).

Notes

For your system to work properly, please follow the links below to download all necessary drivers/utilities and the user's manual for your server.

- Supermicro product manuals: <http://www.supermicro.com/support/manuals/>
- Product drivers and utilities: <https://www.supermicro.com/wdl/driver>
- Product safety info: http://www.supermicro.com/about/policies/safety_information.cfm

If you have any questions, please contact our support team at:
support@supermicro.com

This manual may be periodically updated without notice. Please check the Supermicro website for possible updates to the manual revision level.

Secure Data Deletion

A secure data deletion tool designed to fully erase all data from storage devices can be found on our website: https://www.supermicro.com/about/policies/disclaimer.cfm?url=/wdl/utility/Log9_Secure_Data_Deletion_Utility/

Warnings

Special attention should be given to the following symbols used in this manual.



Warning! Indicates important information given to prevent equipment/property damage or personal injury.



Warning! Indicates high voltage may be encountered when performing a procedure.

Contents

Contacting Supermicro.....	8
Chapter 1 Introduction	
1.1 Overview.....	9
1.2 System Features	10
Front View	10
Control Panel.....	11
Rear View.....	12
1.3 System Architecture	14
Main Components	14
System Block Diagram.....	15
1.4 Motherboard Layout	16
Quick Reference Table.....	17
Chapter 2 Server Installation	
2.1 Overview.....	19
2.2 Unpacking the System	19
2.3 Preparing for Setup.....	19
Choosing a Setup Location.....	19
Rack Precautions	20
Server Precautions.....	20
Rack Mounting Considerations	20
Ambient Operating Temperature.....	20
Airflow	21
Mechanical Loading.....	21
Circuit Overloading	21
Reliable Ground.....	21
2.4 Installing the System into a Rack.....	22
Chapter 3 Maintenance and Component Installation	
3.1 Removing Power	23
3.2 Accessing the System.....	24
Removing the Top Cover.....	24
3.3 Static-Sensitive Devices.....	25
Precautions	25

3.4 Processor and Heatsink Installation.....	26
Installing the LGA1200 Processor	27
Installing the CPU Heatsink	28
3.5 Memory.....	31
Memory Support.....	31
Memory Installation Sequence.....	31
General Memory Population Requirements.....	31
General Guidelines for Optimizing Memory Performance	32
DIMM Installation	33
DIMM Removal	33
3.6 Motherboard Battery.....	34
3.7 Storage Drives.....	35
Installing Drives.....	35
Installing M.2 Solid State Drives	36
3.8 System Cooling	37
Fans	37
Installing Fans.....	37
Air Shrouds	39
3.9 Expansion Cards	40
Riser Cards	40
Installing Expansion Cards	41
3.10 Power Supply	42
3.11 BMC	43
Chapter 4 Motherboard Connections	
4.1 Power Connections	44
4.2 Headers and Connectors	46
Control Panel.....	50
4.3 Input/Output Ports	53
I/O Ports.....	53
4.4 Jumpers.....	56
4.5 LED Indicators.....	60
4.6 Storage Ports	61
Chapter 5 Software	
5.1 Microsoft Windows OS Installation.....	62

5.2 Driver Installation.....	64
5.3 SuperDoctor® 5.....	65
5.4 IPMI	66
BMC ADMIN User Password	66
Chapter 6 Optional Components	
6.1 Storage Drive Options.....	67
6.2 Cable Management Arm.....	68
6.3 TPM Security Module	70
Chapter 7 Troubleshooting and Support	
7.1 Information Resources	71
Website	71
Direct Links for the SYS-110C-FHN4T System.....	71
Direct Links for General Support and Information	71
7.2 Intelligent Platform Management Interface (IPMI)	72
7.3 Troubleshooting Procedures	73
No Power	73
No Video	74
System Boot Failure	74
Memory Errors	74
Losing the System's Setup Configuration.....	74
When the System Becomes Unstable	74
7.4 POST Codes	76
7.5 Crash Dump Using IPMI.....	76
7.6 UEFI BIOS Recovery	77
Overview	77
Recovering the UEFI BIOS Image.....	77
Recovering the Main BIOS Block with a USB Device.....	77
7.7 CMOS Clear.....	82
7.8 Where to Get Replacement Components	83
7.9 Reporting an Issue	83
Technical Support Procedures	83
Returning Merchandise for Service.....	83
Vendor Support Filing System	84
7.10 Feedback.....	84
7.11 Contacting Supermicro.....	85

Appendix A Standardized Warning Statements for AC Systems
Appendix B System Specifications

BSMI/RoHS108

Contacting Supermicro

Headquarters

Address: Super Micro Computer, Inc.
980 Rock Ave.
San Jose, CA 95131 U.S.A.

Tel: +1 (408) 503-8000

Fax: +1 (408) 503-8008

Email: marketing@supermicro.com (General Information)
Sales-USA@supermicro.com (Sales Inquiries)
Government_Sales-USA@supermicro.com (Gov. Sales Inquiries)
support@supermicro.com (Technical Support)
RMA@supermicro.com (RMA Support)
Webmaster@supermicro.com (Webmaster)

Website: www.supermicro.com

Europe

Address: Super Micro Computer B.V.
Het Sterrenbeeld 28, 5215 ML
's-Hertogenbosch, The Netherlands

Tel: +31 (0) 73-6400390

Fax: +31 (0) 73-6416525

Email: Sales_Europe@supermicro.com (Sales Inquiries)
Support_Europe@supermicro.com (Technical Support)
RMA_Europe@supermicro.com (RMA Support)

Website: www.supermicro.nl

Asia-Pacific

Address: Super Micro Computer, Inc.
3F, No. 150, Jian 1st Rd.
Zhonghe Dist., New Taipei City 235
Taiwan (R.O.C)

Tel: +886-(2) 8226-3990

Fax: +886-(2) 8226-3992

Email: Sales-Asia@supermicro.com.tw (Sales Inquiries)
Support@supermicro.com.tw (Technical Support)
RMA@supermicro.com.tw (RMA Support)

Website: www.supermicro.com.tw

Chapter 1

Introduction

1.1 Overview

This chapter provides a brief outline of the functions and features of the SuperServer® SYS-110C-FHN4T.

The following provides an overview of the specifications and capabilities.

System Overview	
Motherboard	X12SCZ-TLN4F
Chassis	CSE-510FT-203B
Processor Support	Single socket 10th Generation Intel® Core™ i9 ~ i3 Processor, Intel® Xeon® W-1200 Processors
Memory	Four DIMM slots, up to 128GB unbuffered ECC/non-ECC UDIMM, ECC DDR4 UDIMM with speeds up to 2933MT/s
Drive Support	Two 2.5" hot-swap SATA drive bays One M.2 NVMe or Two M.2 SATA3 (M-Key/E-Key, 2280/22110/2230)
Expansion Slots	One PCIe 3.0 x16 slots HHHL
I/O Ports	One RJ45 Dedicated IPMI LAN port Two RJ45 10GBase-T LAN ports Two RJ45 GbE LAN ports Four USB 3.0 ports (4 rear) One VGA port (1 rear) One DVI-D port Two display ports with dual-mode Two SATA3 (6Gbps); RAID 0/1 support One SuperDOM (Disk on Module) port
System Cooling	Four 4cm PWM heavy duty fans with optimal fan speed control One air shroud
Power	One power supply default: 200W (80Plus Gold Level)
Form Factor	1U Rackmount 1.7 x 17.2 x 11.3in. / 43 x 437 x 287mm (HxWxD)

Notes: A Quick Reference Guide can be found on the product page of the Supermicro website.

The following safety models associated with the SYS-110C-FHN4T have been certified as compliant with UL or CSA: 510-2, 510F-2, 510F-S2X12.

1.2 System Features

The following views of the system display the main features. Refer to [Appendix B](#) for additional specifications.

Front View

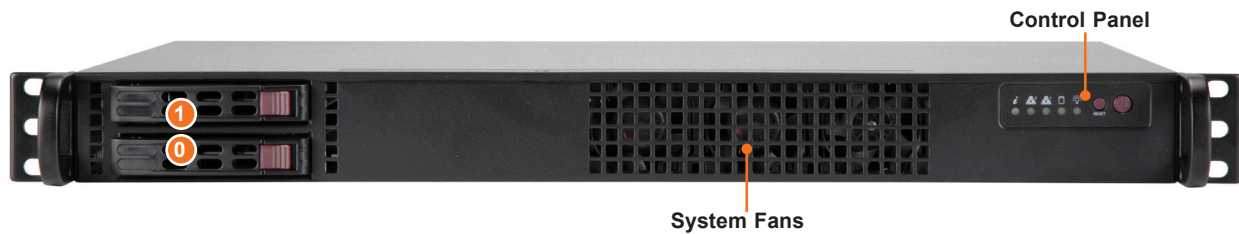

Figure 1-1. Front View

System Features: Front	
Feature	Description
Control Panel	One control panel (see Control Panel for details)
System Fans	Three front internal fans

Logical Storage Drive Numbers	
Item	Description
0 - 1	Two hot-swap 2.5" SATA3 drive bays

Control Panel

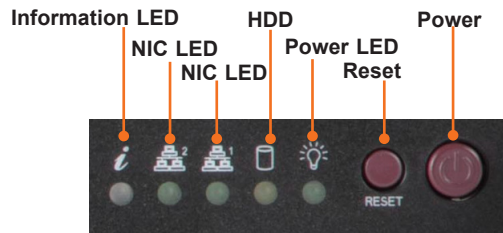

Figure 1-2. Control Panel

Control Panel Features	
Feature	Description
Information LED	Alerts operator to several states, as noted in the table below.
NIC LED	Indicates network activity on LANs when flashing.
NIC LED	Indicates network activity on LANs when flashing.
HDD	Indicates activity on the storage drives when flashing.
Power LED	Steady on – Power on Blinking at 4Hz – Checking BIOS/BMC integrity Blinking at 4Hz and "i" LED is blue – BIOS firmware updating Two blinks at 4Hz, one pause 2hz and "i" LED blue – BMC firmware updating Blinking at 1Hz and "i" LED red – Fault detected
Reset	This button is used to reset the system.
Power button	The main power switch applies or removes primary power from the power supply to the server but maintains standby power. Hold for four seconds to force a shut-down.

Information LED	
Color, Status	Description
Red, solid	An overheat condition has occurred.
Red, blinking at 1Hz	Fan failure, check for an inoperative fan.
Red, blinking at 0.25Hz	Power failure, check for a non-operational power supply.
Red, solid, with Power LED blinking green	Fault detected
Blue and red, blinking at 10 Hz	Recovery mode
Blue, solid	UID has been activated locally to locate the server in a rack environment.
Blue, blinking at 1Hz	UID has been activated using the IPMI to locate the server in a rack environment.
Blue, blinking at 2Hz	BMC is resetting
Blue, blinking at 4Hz	BMC is setting factory defaults
Blue, blinking at 10Hz with Power LED blinking green	BMC/BIOS firmware is updating

Rear View

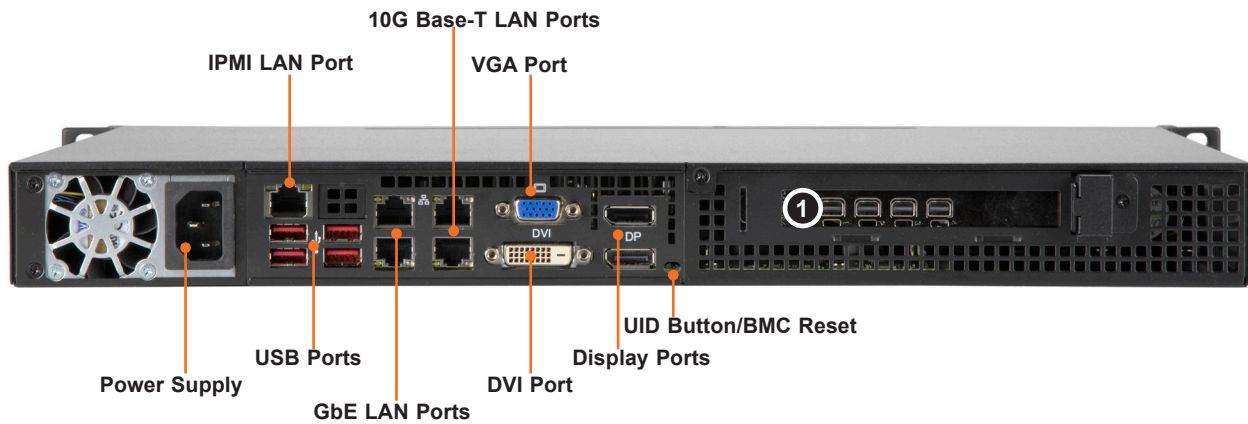

Figure 1-3. System: Rear View

System Features: Rear	
Feature	Description
Power Supply	One power supply module
USB	Four USB 3.2 ports
IPMI LAN Port	One RJ45 dedicated IPMI LAN port
GbE LAN Ports	Two RJ45 GbE LAN ports
10G Base-T LAN Ports	Two RJ45 10G Base-T LAN ports
DVI Port	One DVI-D port for digital connection
VGA Port	One VGA port
Display Ports	Two display ports with dual-mode
UID Button/BMC Reset	The unit identification (UID) button turns on or off the blue light function of the Information LED. This button can also be used to reset the BMC .
①	One PCIe 3.0 x16 slot (HHHL)

Power Supply Indicators		
Power Supply Condition	Green LED	Amber LED
No AC Power to Power Supply	OFF	OFF
Power Supply critical events causing a shutdown/ failure/ OCP/ OVP/ Fan Fail/ OTP/ UVP	OFF	ON
Power Supply Warning Events Where the power supply continues to operate; High temperature; Over voltage; under voltage, etc.	OFF	1Hz Blinking
AC present only 12VSB ON (PS OFF)	1Hz Blinking	OFF
Output ON and OK	ON	OFF
AC cord unplugged and in redundant mode	OFF	ON

1.3 System Architecture

This section covers the locations of the system's main components, a system block diagram, and a motherboard layout with the connectors and jumpers called out.

Main Components

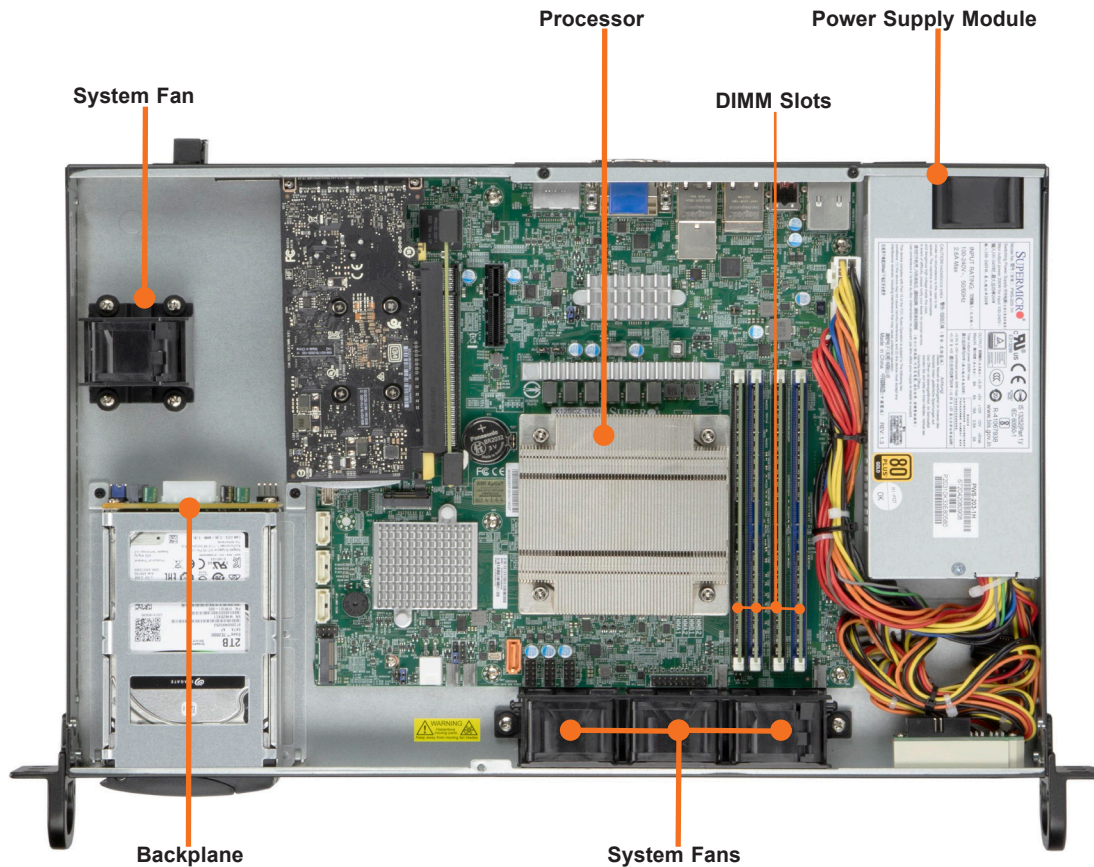

Figure 1-4. Main Component Locations

Main Component Locations	
Feature	Description
Power Supply	One power supply module, PWS-203-1H
DIMM slots	4 DIMM memory slots
Processors	10th Generation Intel® Core™ i9 ~ i3 Processor, Intel® Xeon® W-1200 Processors with heatsinks, SNK-P0049P
System Fans	Four 4-cm dual counter-rotating PWM fans, FAN-0065L4
Backplane	2-port 1U SAS3/SATA3 storage device backplane, BPN-SAS-510T

System Block Diagram

The block diagram below shows the connections and relationships between the subsystems and major components of the overall system.

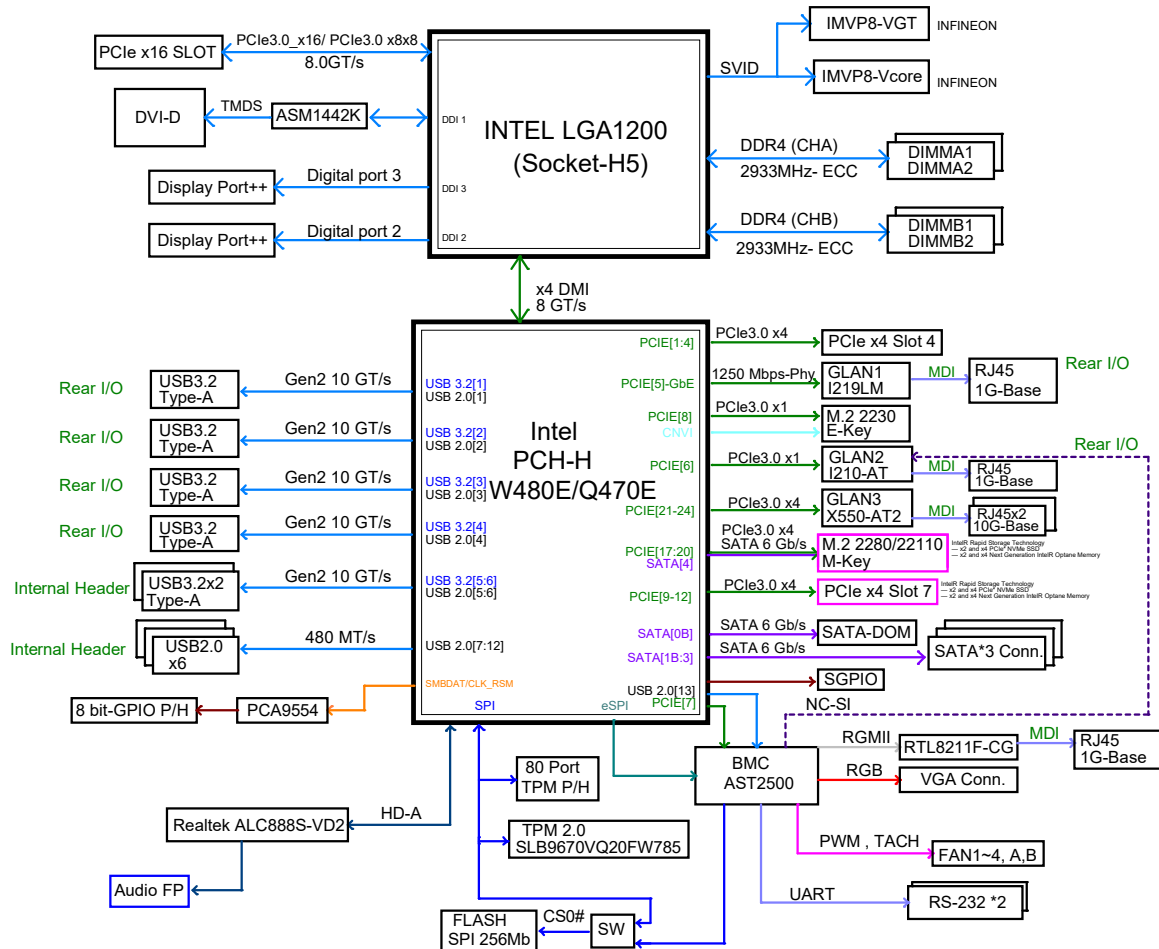

Figure 1-5. System Block Diagram

1.4 Motherboard Layout

Below is a layout of the X12SCZ-TLN4F motherboard with a jumper, connector, and LED locations shown. See the table on the following page for descriptions. For detailed descriptions, pinout information, and jumper settings, refer to [Chapter 4](#) or the [Motherboard Manual](#).

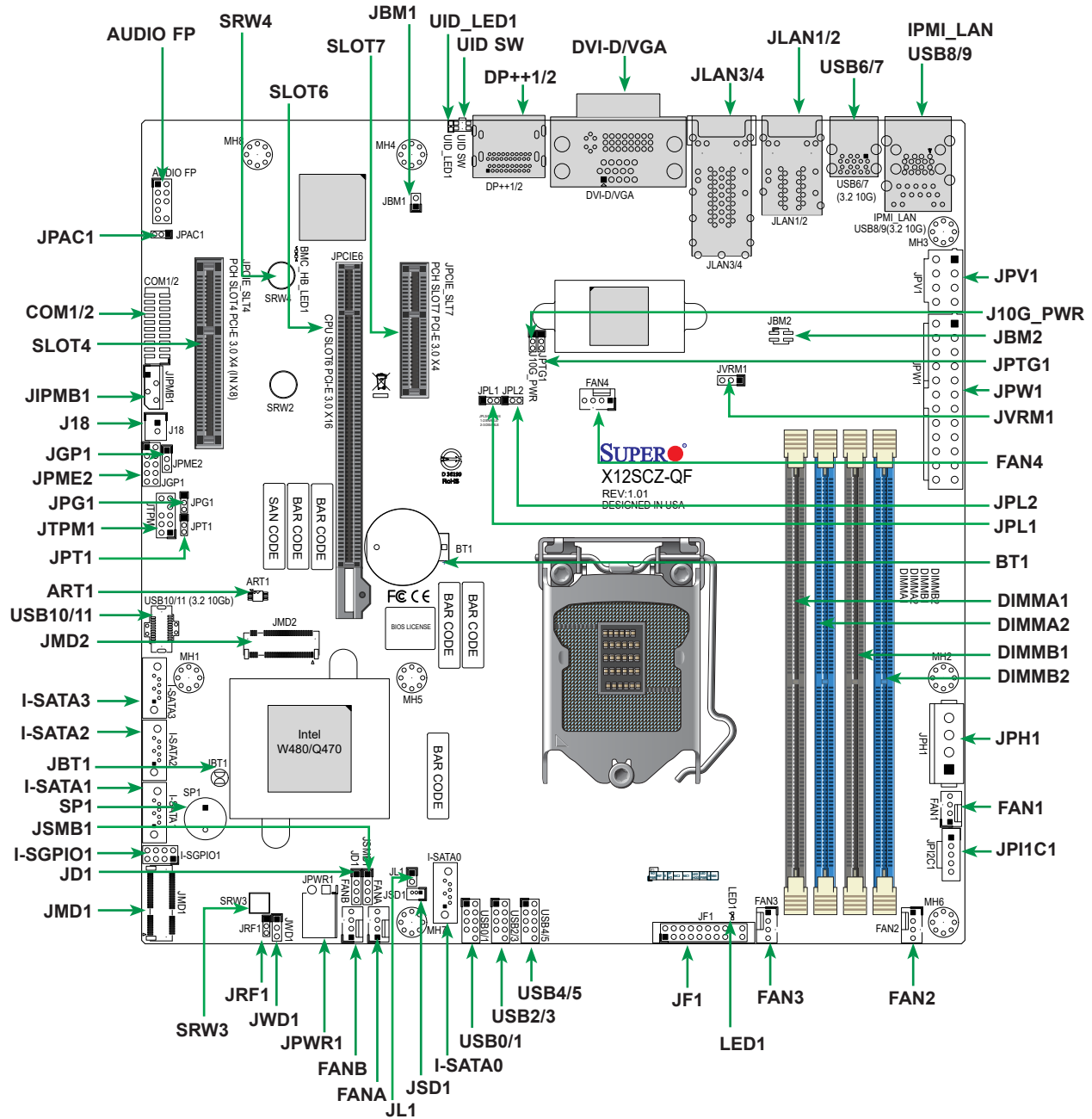

Figure 1-6. Motherboard Layout

Quick Reference Table

Jumper	Description	Default Setting
J10G_PWR	X550 PWR	Pins 1-2: Standby Power
JBM1	Disable IPMI share LAN	Pins 1-2 Open (Enabled)
JBM2	Disable IPMI dedicated/share LAN	Pins 1-2 Open (Enabled)
JBT1	CMOS clear	Open (Normal)
JPAC1	Audio enable	Pins 1-2 (Enabled)
JPG1	VGA Enable/Disable	Pins 1-2 (Enabled)
JPL1	LAN1 Enable/Disable	Pins 1-2 (Enabled)
JPL2	LAN2 Enable/Disable	Pins 1-2 (Enabled)
JPME2	ME manufacturing mode	Pins 1-2 (Normal)
JRF1	PCIe bifurcation	Pins 1-2: PEDG 1x16
JPT1	Onboard TPM module Enable/Disable	Pins 2-3 (Disabled)
JPTG1	LAN3/LAN4 (10G Base-T) Enable/Disable	Pins 1-2 (Enabled)
JWD1	Watch dog timer	Pins 1-2 (Reset) Pins 2-3 (NMI)

LED	Description	Status
BMC_HB_LED1	BMC heartbeat LED	Blinking Green: BMC Normal
UID_LED1	Unit Identifier (UID) LED	Solid Blue: Unit Identified
LED1	Power LED	Solid Green: Power On Blinking Green: S3 Status

Connector	Description
ART1	M.2 M-Key temperature sensor
AUDIO_FP	Front panel audio header
BT1	Onboard battery
COM1/2	COM header (supports RS-232)
DP++ 1/2	DisplayPorts 1 and 2
DVI-D/VGA	Back panel DVI-D/VGA port
FAN1 - FAN4	CPU/System fan headers (FAN1: CPU Fan)
FANA, FANB	I/O fan header
IPMI_LAN	Dedicated IPMI LAN port
I-SATA0 - I-SATA3	Intel® PCH SATA 3.0 Ports (I-SATA0: SATA DOM)
I-SGPIO1	Serial link general purpose I/O header
J18	Extended CMOS battery connector
JD1	Speaker header (Pins 1-4: Speaker, Pins 3-4: Buzzer)
JF1	Front control panel header

Note: Table is continued on the next page.

Connector	Description
JGP1	General purpose I/O header
JIPMB1	4-pin BMC external I ² C header (for an IPMI card)
JL1	Chassis intrusion header
JLAN1/2	1G Base-T LAN ports
JLAN3/4	10G Base-T LAN ports
JMD1	M.2 E-Key 2230 (CNVi/CNV) slot
JMD2	M.2 M-Key 2280/22110 slot
JPCIE_SLT4	PCH PCIe 3.0 x4 (IN x8) slot
JPCIE6	CPU PCIe 3.0 x16 slot
JPCIE_SLT7	PCH PCIe 3.0 x4 slot
JPH1	4-pin HDD power connector
JPI ² C1	Power System Management Bus (SMB) I ² C header
JPV1	8-pin 12V DC power connector for CPU (required) or alternative single power for special enclosure when the 24-pin ATX power is not in use
JPW1	24-pin ATX power connector
JPWR1	4-pin 12V power connector for GPU card requiring extra 12V power up to 75W
JSD1	SATA DOM power connector
JSMB1	System management bus header
JTPM1	Trusted Platform Module/Port 80 connector
JVRM1	VRM bus header
SP1	Internal Buzzer/Speaker
SRW2	M.2 holding screws for M-Key Type 2280
SRW3	M.2 holding screws for E-Key Type 2230
SRW4	M.2 holding screws for M-Key Type 22110
UID SW	Unit Identifier Switch
USB0/1, 2/3, 3/4	Front accessible USB 2.0 ports
USB6/7, 8/9	Rear I/O USB 3.2 (10Gb) ports
USB10/11	USB 3.2 (10Gb) Type-A header

Chapter 2

Server Installation

2.1 Overview

This chapter provides advice and instructions for mounting your system in a server rack. If your system is not already fully integrated with processors, system memory, etc., refer to [Chapter 3](#) for details on installing those specific components.

Important! Electrostatic Discharge (ESD) can damage electronic components. To prevent such damage to PCBs (printed circuit boards), it is important to use a grounded wrist strap, handle all PCBs by their edges and keep them in anti-static bags when not in use.

2.2 Unpacking the System

Inspect the box in which the system was shipped, and note if it was damaged in any way. If any equipment appears damaged, file a damage claim with the carrier who delivered it.

Decide on a suitable location for the rack unit that will hold the server. It should be situated in a clean, dust-free area that is well ventilated. Avoid areas where heat, electrical noise, and electromagnetic fields are generated. It will also require a grounded AC power outlet nearby. Be sure to read the precautions and considerations noted or in [Appendix A](#).

2.3 Preparing for Setup

The box in which the system was shipped should include the rackmount hardware needed to install it into the rack. Please read this section in its entirety before you begin the installation.

Choosing a Setup Location

- The system should be situated in a clean, dust-free area that is well ventilated. Avoid areas where heat, electrical noise, and electromagnetic fields are generated.
- Leave enough clearance in front of the rack so that you can open the front door completely (~25 inches) and approximately 30 inches of clearance in the back of the rack to allow sufficient space for airflow and access when servicing.
- This product should be installed only in a Restricted Access Location (dedicated equipment rooms, service closets, etc.).
- This product is not suitable for use with visual display workplace devices according to §2 of the German Ordinance for Work with Visual Display Units.

Rack Precautions

- Ensure that the leveling jacks on the bottom of the rack are extended to the floor so that the full weight of the rack rests on them.
- In single rack installations, stabilizers should be attached to the rack. In multiple rack installations, the racks should be coupled together.
- Always make sure the rack is stable before extending a server or other component from the rack.
- You should extend only one server or component at a time - extending two or more simultaneously may cause the rack to become unstable.

Server Precautions

- Review the electrical and general safety precautions in [Appendix A](#).
- Determine the placement of each component in the rack *before* you install the rails.
- Install the heaviest server components at the bottom of the rack first and then work your way up.
- Use a regulating uninterruptible power supply (UPS) to protect the server from power surges and voltage spikes and to keep your system operating in case of a power failure.
- Allow any drives and power supply modules to cool before touching them.
- When not servicing, always keep the front door of the rack and all covers/panels on the servers closed to maintain proper cooling.

Rack Mounting Considerations

Ambient Operating Temperature

If installed in a closed or multi-unit rack assembly, the ambient operating temperature of the rack environment may be greater than the room's ambient temperature. Therefore, consideration should be given to installing the equipment in an environment compatible with the manufacturer's maximum rated ambient temperature (TMRA).

Airflow

Equipment should be mounted into a rack so that the amount of airflow required for safe operation is not compromised.

Mechanical Loading

Equipment should be mounted into a rack so that a hazardous condition does not arise due to uneven mechanical loading.

Circuit Overloading

Consideration should be given to the connection of the equipment to the power supply circuitry and the effect that any possible overloading of circuits might have on overcurrent protection and power supply wiring. Appropriate consideration of equipment nameplate ratings should be used when addressing this concern.

Reliable Ground

A reliable ground must be maintained at all times. To ensure this, the rack itself should be grounded. Particular attention should be given to power supply connections other than the direct connections to the branch circuit (i.e. the use of power strips, etc.).

Warning!



Stability hazard. The rack may tip over causing serious personal injury. Before extending the rack to the installation position, read the installation instructions. Do not put any load on the slide-rail mounted equipment in the installation position. Do not leave the slide-rail mounted equipment in the installation position..

Avertissement!



Danger d'instabilité. Le rack peut basculer et provoquer des blessures corporelles graves. Avant d'étendre le rack en position d'installation, lire les instructions d'installation. Ne pas charger l'équipement monté sur rail de glissière en position d'installation.

Important! To prevent bodily injury when mounting or servicing this unit in a rack, you must take special precautions to ensure that the system remains stable. The following guidelines are provided to ensure your safety:

- This unit should be mounted at the bottom of the rack if it is the only unit in the rack.
- When mounting this unit in a partially filled rack, load the rack from the bottom to the top with the heaviest component at the bottom of the rack.
- If the rack is provided with stabilizing devices, install the stabilizers before mounting or servicing the unit in the rack.
- Slide rail mounted equipment is not to be used as a shelf or a workspace.
- Do not pick up the server with the front handles. They are designed to pull the system from a rack only.

2.4 Installing the System into a Rack

The following is a basic guideline for installing the system into a rack with the rack mounting hardware provided. You should also refer to the installation instructions that came with the specific rack you are using.

1. Confirm that the chassis includes the four mounting screws required to mount the chassis into a rack.
2. Align the thru-holes of the chassis with the thru-holes of the rack.
3. Insert the mounting screws into the thru-holes in the front of the chassis and through the thru-holes in the rack

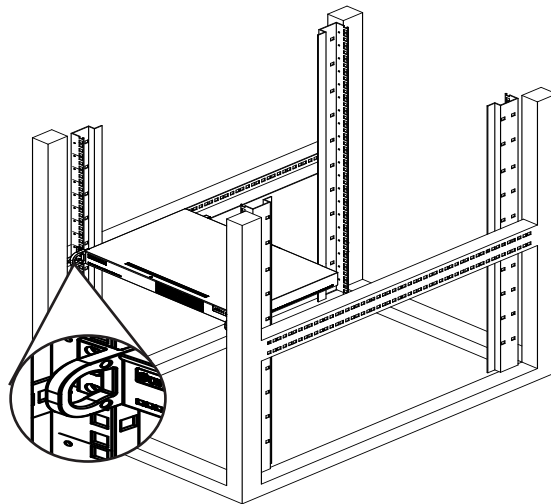

Figure 2-1. Installing the System into a Rack

Note: Figure is for illustrative purposes only. Always install servers to the bottom of a rack first.

Important! Stability hazard. The rack stabilizing mechanism must be in place, or the rack must be bolted to the floor before you slide the unit out for servicing. Failure to stabilize the rack can cause the rack to tip over.

Chapter 3

Maintenance and Component Installation

This chapter provides instructions on installing and replacing main system components. To prevent compatibility issues, only use components that match the specifications and/or part numbers given.

Installation or replacement of most components requires that power first be removed from the system. Please follow the procedures given in each section.

3.1 Removing Power

Use the following procedure to ensure that power has been removed from the system. This step is necessary when removing or installing non-hot-swap components or when replacing a non-redundant power supply.

1. Use the operating system to power down the system.
2. After the system has completely shut-down, disconnect the AC power cord(s) from the power strip or outlet. (If your system has more than one power supply, remove the AC power cords from all power supply modules.)
3. Disconnect the power cord(s) from the power supply module(s).

3.2 Accessing the System

The 510FT-203B chassis features a removable top cover, which allows easy access to the inside of the chassis.

Removing the Top Cover

1. Press the release button and slide the cover toward the rear.
2. Lift the top cover-up.

Check that all ventilation openings on the top cover and the top of the chassis are clear and unobstructed.

Important! Except for short periods of time, do not operate the server without the cover in place. The chassis cover must be in place to allow for proper airflow and to prevent overheating.

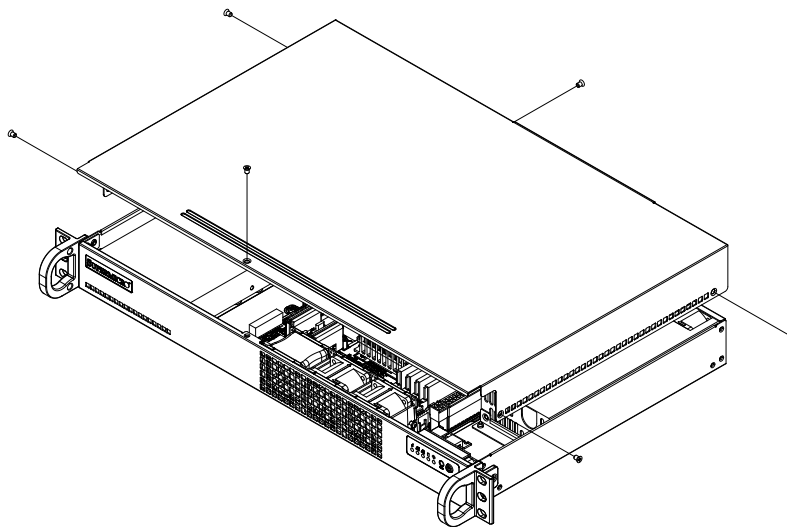

Figure 3-1. Removing the Chassis Cover

3.3 Static-Sensitive Devices

Electrostatic Discharge (ESD) can damage electronic components. To avoid damaging your motherboard, it is important to handle it very carefully. The following measures are generally sufficient to protect the system PCBs from ESD.

Precautions

- Use a grounded wrist strap designed to prevent static discharge.
- Touch a grounded metal object before removing any PCB (printed circuit board) from its antistatic bag.
- Handle PCBs by their edges only; do not touch its components, peripheral chips, memory modules, or gold contacts.
- When handling chips or modules, avoid touching their pins.
- Put the PCBs back into their antistatic bags when not in use.
- Use only the correct type of onboard CMOS battery. Do not install the onboard battery upside down to avoid a possible explosion.

3.4 Processor and Heatsink Installation

Follow the procedures in this section to install a processor (CPU) and heatsink to the motherboard.

Notes:

- The motherboard should be installed into the chassis first and the processor should be installed into the CPU socket before you install a CPU heatsink.
- If you bought a CPU separately, make sure that you use an Intel-certified multi-directional heatsink only.
- When receiving a motherboard without a processor pre-installed, make sure that the plastic CPU socket cap is in place and none of the socket pins are bent; otherwise, contact your retailer immediately.
- When installing the heatsink, ensure a torque driver set to the correct force is used for each screw.
- Refer to the Supermicro website for updates on CPU support.

Installing the LGA1200 Processor

1. Remove power from the system as described in Section 3.1.
2. Press the load lever down to release the load plate from its locking position.

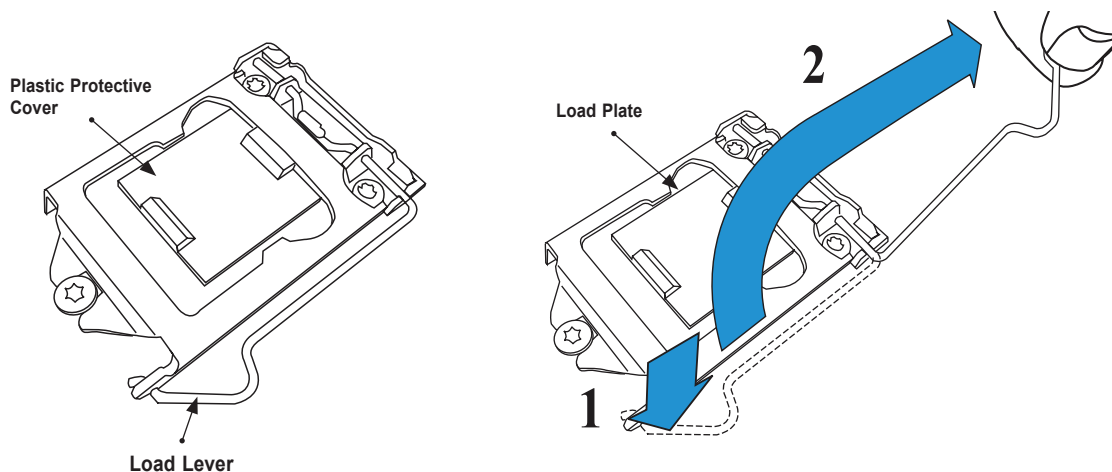

3. Gently lift the load lever to open the load plate. Remove the plastic protective cover. Do not touch the CPU socket contacts.

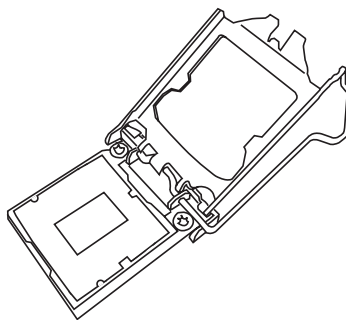

4. Locate the triangle on the CPU and CPU socket, which indicates the location of Pin 1. Holding the CPU by the edges with your thumb and index finger, align the triangle on the CPU with the triangle on the socket. The CPU keys (the semi-circle cutouts) may also be aligned against the socket keys as a guide.

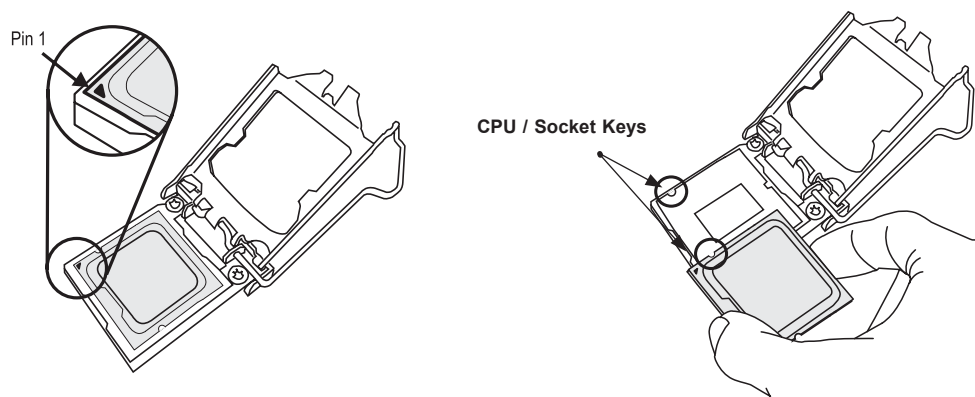

- Carefully lower the CPU straight down into the socket. Do not drop the CPU on the socket, or move it horizontally or vertically to avoid damaging the CPU or socket. Inspect the four corners of the CPU to make sure that the CPU is properly installed.

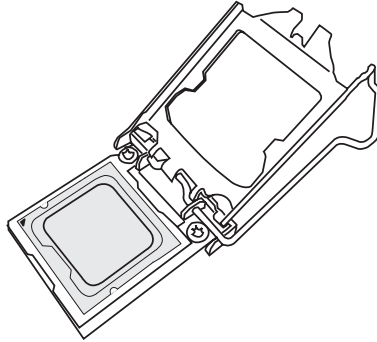

- Close the load plate, then gently push down the load lever into its locking position.

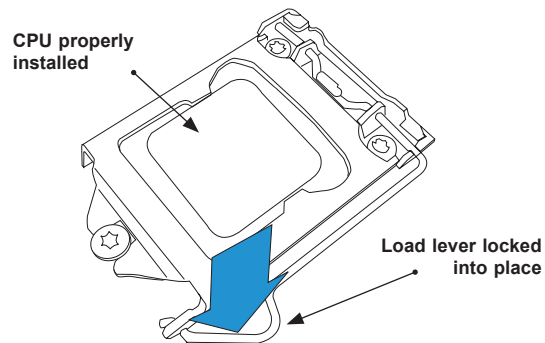

Installing the CPU Heatsink

Notes:

- If you bought a CPU separately, use an Intel-certified heatsink only.
 - Do not apply any thermal grease to the heatsink or the CPU die; the required amount has already been applied.
- Place the heatsink on top of the CPU so that the four mounting holes are aligned with those on the heatsink retention bracket.
 - With a T30 bit torque driver **set to a force of 7 in-lbf (8.0 kgf-cm)**, gradually tighten the four screws to ensure even pressure. You can start with any screw, but make sure to tighten the screws in a diagonal pattern.

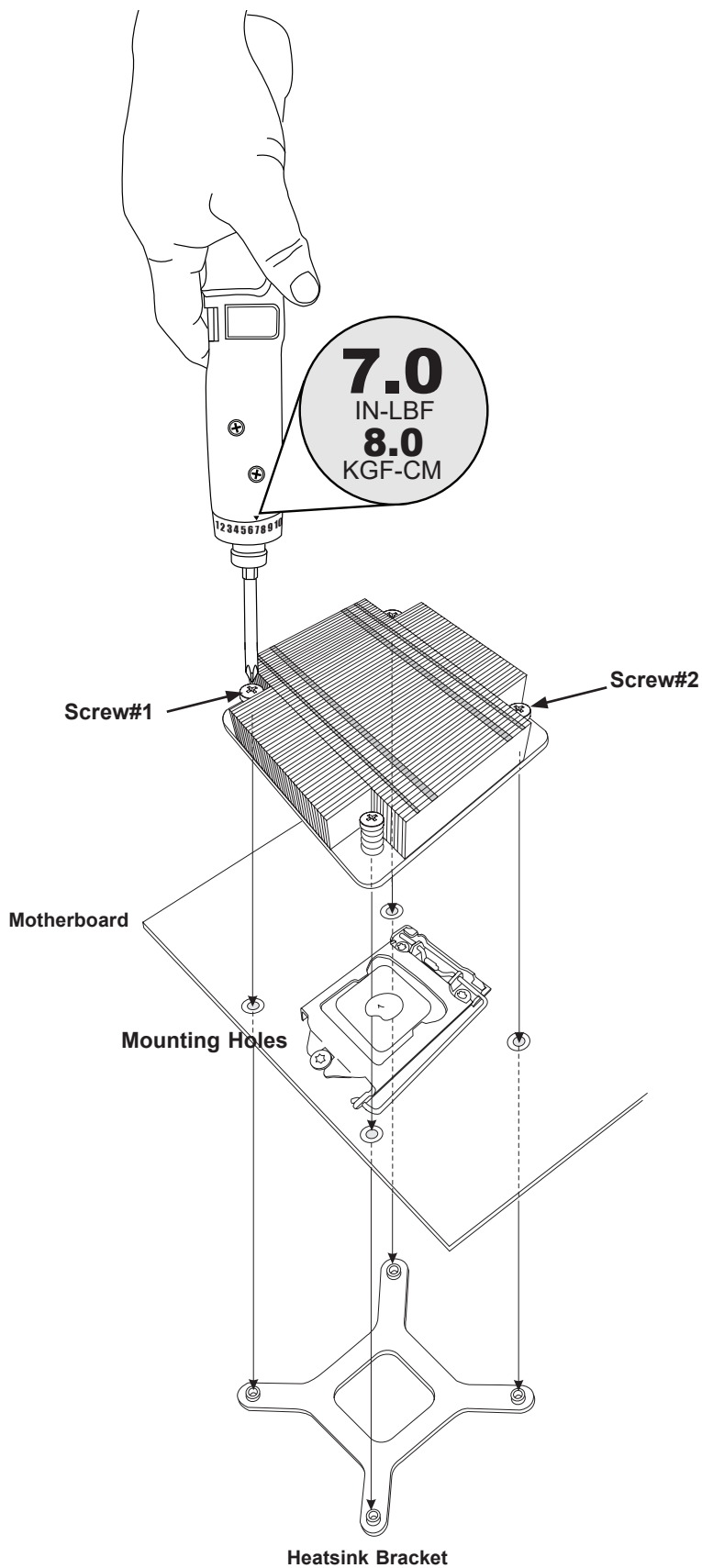

Figure 3-2. Installing the Heatsink

Removing a Heatsink

We do not recommend removing the heatsink. If necessary, please follow the instructions below to prevent damage to the CPU or the CPU socket.

1. Unscrew and remove the heatsink screws from the motherboard in the sequence as show in the figure below.
2. Hold and gently pivot the heatsink back and forth to loosen it from the CPU. (Do not use excessive force when dislodging the heatsink.)
3. Once the heatsink is loose, remove it from the CPU.
4. Clean the surface of the CPU and the heatsink to get rid of the old thermal grease. Reapply the proper amount of thermal grease to the surface before you re-install the heatsink.

Note: Wait for the heatsink to cool down before removing it.

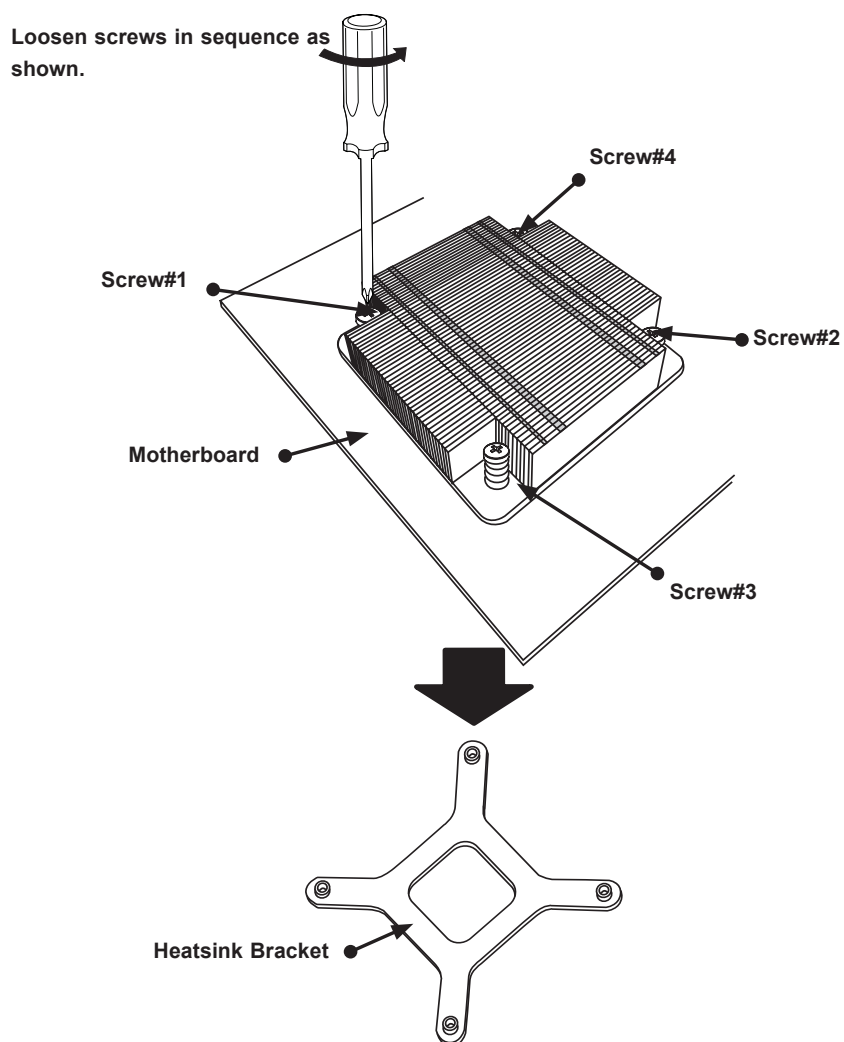

Figure 3-3. Removing the Heatsink

3.5 Memory

Memory Support

The X12SCZ-TLN4F has 4 DIMM slots to support up to 128GB unbuffered ECC/non-ECC UDIMM, ECC DDR4 UDIMM with speeds up to 2933MT/s.

For validated memory, use our [Product Resources page](#). Check the Supermicro website for possible updates to memory support.

Memory Installation Sequence

Memory for this motherboard is populated using the "Fill First" method. The DIMM slots with blue release tabs are considered the first DIMM of their channel, and those with white release tabs are the second of the channel. When installing memory modules, be sure to populate the memory slots with the blue release tabs first and then populate those with the white release tabs.

General Memory Population Requirements

1. Be sure to use the memory modules of the same type and speed on the motherboard. Mixing of memory modules of different types and speeds is not allowed.
2. Using unbalanced memory topology such as populating two DIMMs in one channel while populating one DIMM in another channel will result in the reduced memory performance.
3. Populating memory slots with a pair of DIMM modules of the same type and size will result in interleaved memory, which will improve memory performance.

Recommended Population (Balanced)				
DIMMA1	DIMMB1	DIMMA2	DIMMB2	Total System Memory
		2GB	2GB	4GB
2GB	2GB	2GB	2GB	8GB
		4GB	4GB	8GB
4GB	4GB	4GB	4GB	16GB
		8GB	8GB	16GB
8GB	8GB	8GB	8GB	32GB
		16GB	16GB	32GB
16GB	16GB	16GB	16GB	64GB
		32GB	32GB	64GB
32GB	32GB	32GB	32GB	128GB

General Guidelines for Optimizing Memory Performance

- The blue slots must be populated first. DIMM slots must be populated in the following order: DIMMB2, DIMMA2, then DIMMB1, DIMMA1.
- Always use DDR4 memory of the same type, and size.
- Mixed DIMM speeds can be installed. However, all DIMMs will run at the speed of the slowest DIMM.
- The motherboard will support odd-numbered modules (one or three modules installed). However, to achieve the best memory performance, a balanced memory population is recommended.

DIMM Installation

1. Insert the desired number of DIMMs into the slots based on the recommended DIMM population tables shown above.
2. Push the release tabs on both ends of the DIMM slot outwards to unlock it.

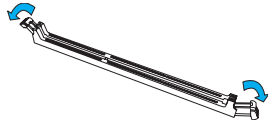

3. Align the key of the DIMM module with the receptive point on the memory slot.

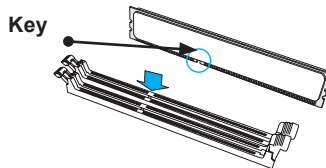

4. Align the notches on both ends of the module with the receptive points on the ends of the slot.

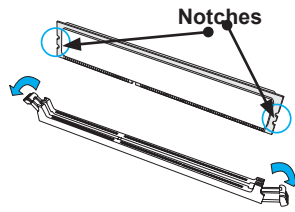

5. Push both ends of the module straight down into the slot until the module snaps into place.

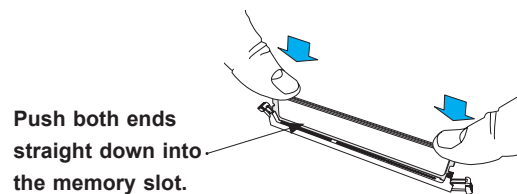

6. Press the release tabs to the lock positions to secure the DIMM module into the slot.

DIMM Removal

Press both release tabs on the ends of the DIMM module to unlock it. Once the DIMM module is loose, remove it from the memory slot.

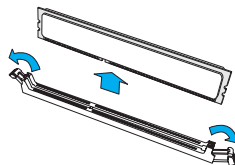

Important! To avoid causing any damage to the DIMM module or the DIMM socket, do not use excessive force when pressing the release tabs on the ends of the DIMM socket. Handle DIMMs with care. Be aware and follow the ESD instructions given at the beginning of this chapter.

3.6 Motherboard Battery

The motherboard uses non-volatile memory to retain system information when system power is removed. This memory is powered by a lithium battery residing on the motherboard.

Replacing the Battery

Begin by [removing power](#) from the system.

1. Push aside the small clamp that covers the edge of the battery. When the battery is released, lift it out of the holder.
2. To insert a new battery, slide one edge under the lip of the holder with the positive (+) side facing up. Then push the other side down until the clamp snaps over it.

Note: Handle used batteries carefully. Do not damage the battery in any way; a damaged battery may release hazardous materials into the environment. Do not discard a used battery in the garbage or a public landfill. Please comply with the regulations set up by your local hazardous waste management agency to dispose of your used battery properly.

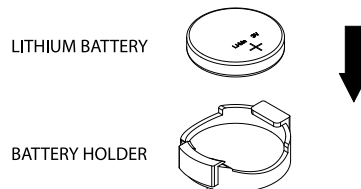

Figure 3-4. Installing the Onboard Battery

Important! There is a danger of explosion if the onboard battery is installed upside down (which reverses its polarities). This battery must be replaced only with the same or an equivalent type recommended by the manufacturer (BR2032).

3.7 Storage Drives

The storage drives are mounted in tool-less drive carriers that simplify their removal from the chassis. These carriers also help promote proper airflow. For compatible storage drives, see the [SYS-110C-FHN4T](#) product page.

Installing Drives



Figure 3-5. Logical Drive Numbers

Installing Fixed 2.5" Hard Drives

The 2.5" hard drives must be installed in brackets before they are screwed into the chassis. Begin by removing power from the system as described in section 3.1 and remove the chassis cover.

1. Insert up to two 2.5" hard drives into the hard drive bracket.
2. Secure the 2.5" hard drives to the bracket with the screws provided.
3. Place the hard drive bracket in the chassis as illustrated in Figure 3-2.
4. Secure the hard drive bracket to the floor of the chassis using the four screws provided.
5. Connect the power and data cables to the motherboard.

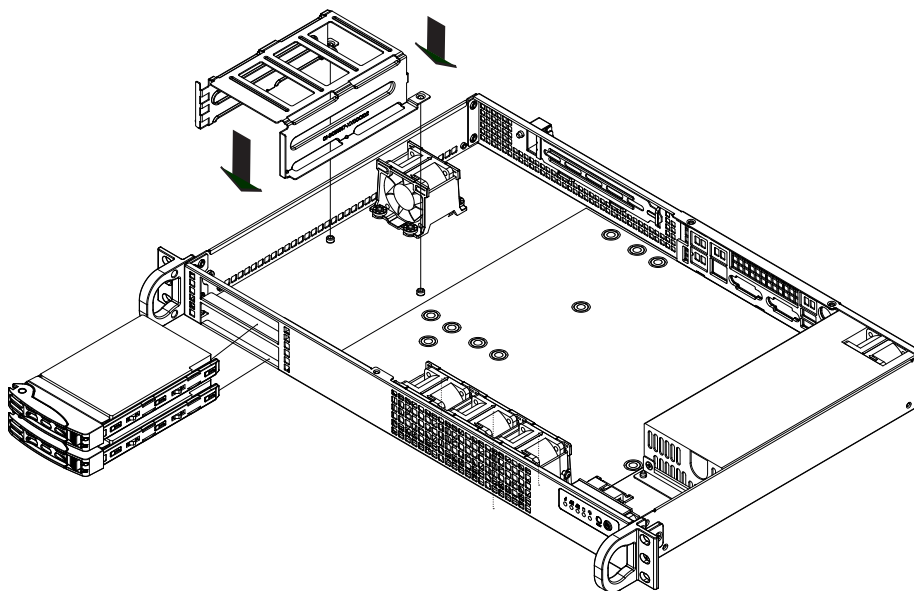

Figure 3-6. Installing 2.5" Drives in the Chassis

Note: Figure is for illustrative purposes only. Only one bracket for two drives can be installed to the 110C-FHN4T.

Installing M.2 Solid State Drives

The X12SCZ-TLN4F motherboard has one hybrid PCIe 3.0 and NVMe or SATA M.2 slots (M.2-H1, M.2-H2). M.2 allows for a variety of card sizes, increased functionality, and spatial efficiency. The M.2 slot on the motherboard supports PCIe 3.0 x1 or SATA 3.0 devices in the 2280 and 22110 form factors.

Installing M.2 Drives

1. Remove power from the system and then remove the top cover as described in Sections 3.1 and 3.2.
2. Refer to its layout image in the [Chapter 1](#) and locate the M.2 slot. Insert the plastic clip into the hole against the M.2 slot on the motherboard.
3. Turn the plastic clip by 90° degrees.
4. Insert the M.2 sideways into the connector so that it lays flat, then secure it to the motherboard with the plastic clip.
5. Repeat as necessary for more M.2 drives.
6. Finish by replacing the cover and restoring power to the system.

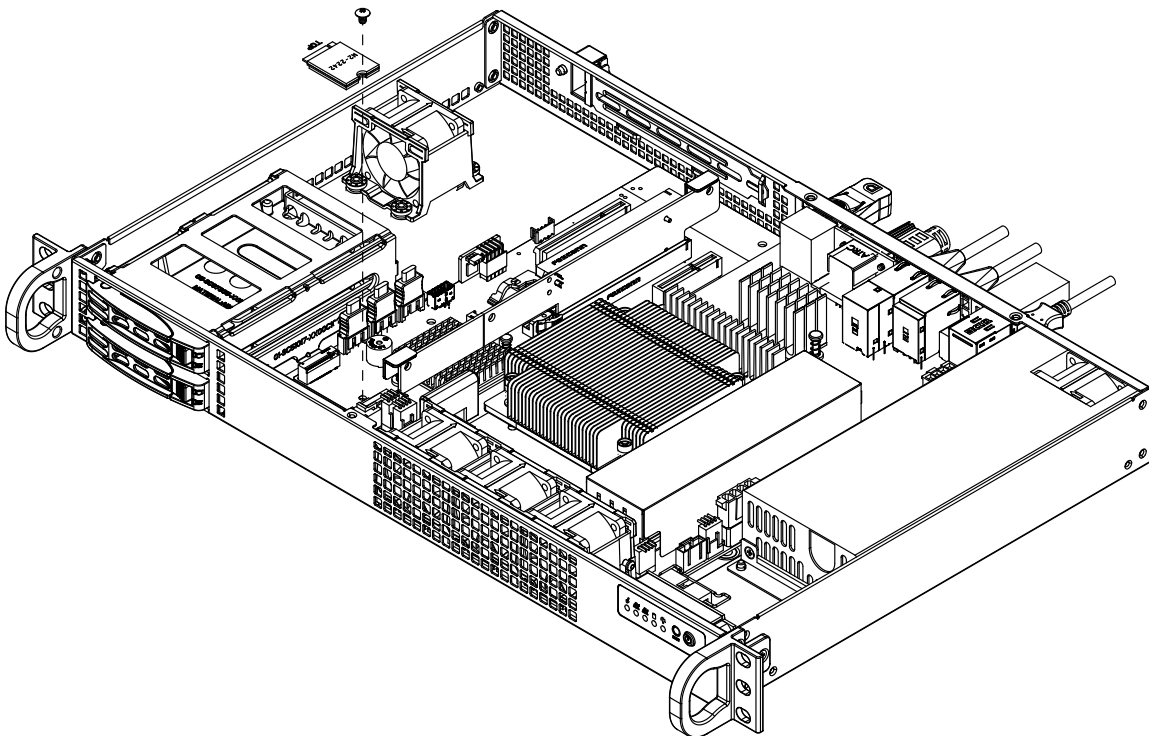

Figure 3-7. Installing an M.2 SSD

3.8 System Cooling

Fans

Four 4-cm heavy-duty fans provide cooling for the system. Fans are hot-swapped and can be replaced without powering down the system. The electrical connections are automatically made when a fan is inserted into its slot.

Make sure the chassis cover is only off for a short time and makes a good seal when replaced for the cooling air to circulate properly through the system.

Installing Fans

Fan speed is controlled by system temperature via IPMI. If a fan fails, the remaining fans will ramp up to full speed. Replace any failed fan at your earliest convenience with the same type and model (the system can continue to run with a failed fan).

1. With the server powered on, remove the chassis cover and inspect the fans to see which one has failed.
2. Power down the server and remove power from the system as described in section 3.1.
3. Remove the fan housing from the chassis by removing the two screws which attach the housing to the chassis. These screws are located in the mounting thru holes on either side of the fan housing. Set these screws aside for later use.

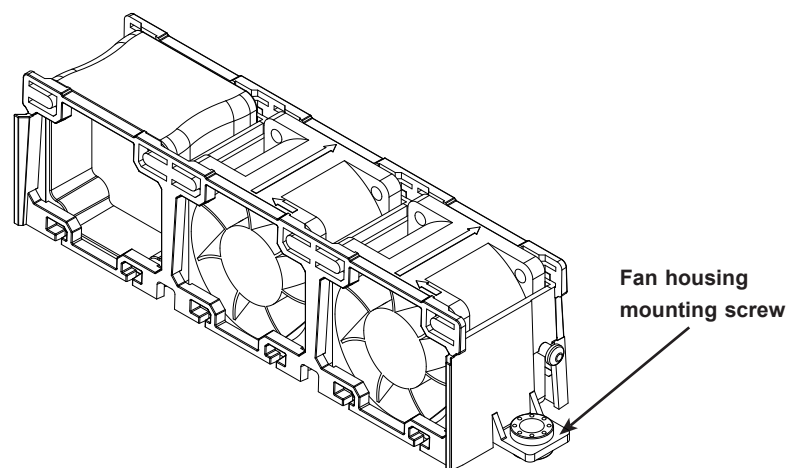

Figure 3-8. System Fans

Note: Figure is for illustrative purposes only. The fan positions may be different in your system.

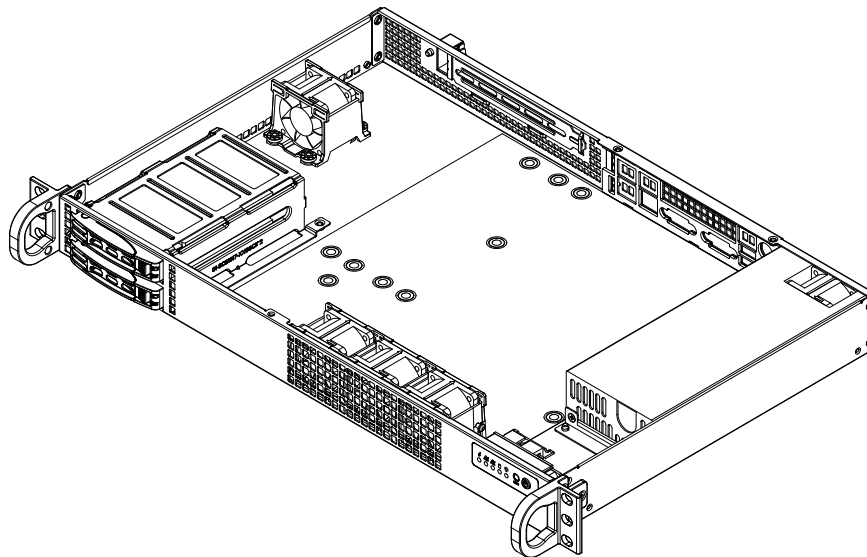

Figure 3-9. Removing the Fan Housing

1. Disconnect the fan wiring from the connectors and carefully lift the fan housing out of the chassis.
2. To remove the fans from the fan housing, gently push upwards on the fan from the underside of the fan housing. Gently ease the fan out of the top of the housing.

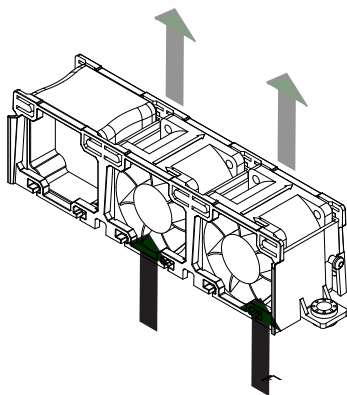

Figure 3-10. Removing/Installing a Fan to the Housing

3. Slide the replacement fan upwards through the bottom of the fan housing.
4. Reconnect the fan wiring and replace the fan housing in the chassis using the mounting screws previously set aside.
5. Power up the system and check that the fan is working properly before replacing the chassis cover.

Air Shrouds

Air shrouds concentrate airflow to maximize fan efficiency. The 110C-FHN4T includes one air shroud.

Air Shroud for Memory

An air shroud cools the DIMM slots controller.

1. Remove the system from the rack and remove the cover as described [previously](#).
2. Place each air shroud over four DIMM slots as illustrated below.
3. Close the cover and push the system back into the rack.

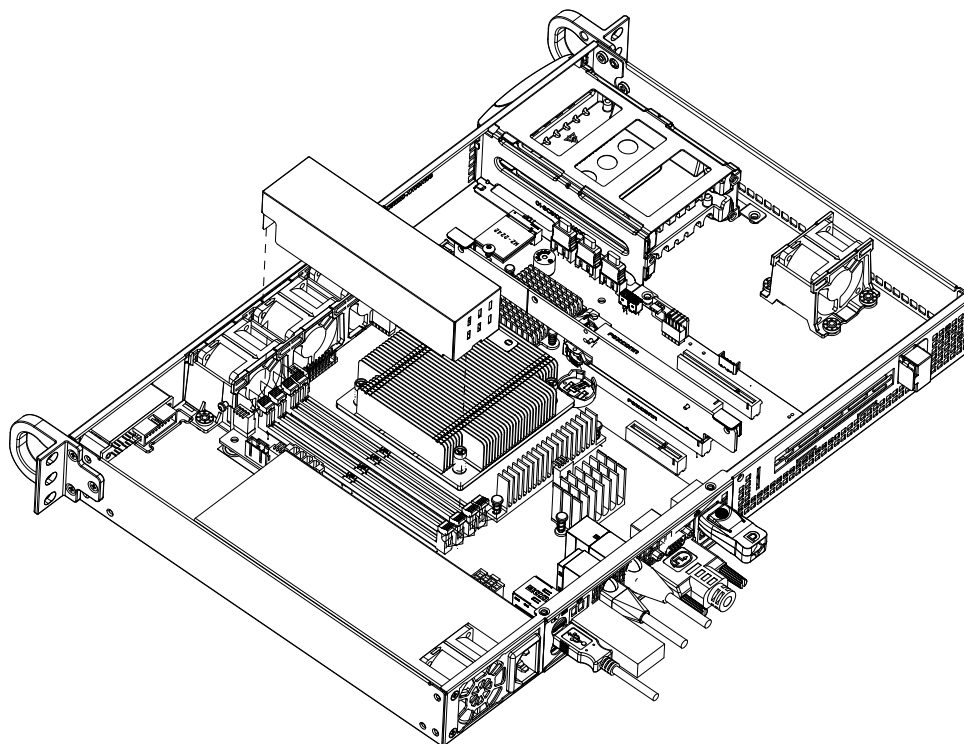

Figure 3-11. Installing Air Shroud for DIMMs

3.9 Expansion Cards

The 110C-FHN4T includes one riser card to support the use of expansion (add-on) cards.



Figure 3-12. Expansion Card Chassis Slots

Riser Cards

This system include riser cards that provide PCIe capabilities.

PCIe Slots per Riser Card			
Riser Card	Part Number	Slot	Description (all PCIe 4.0)
Right (from rear)	RSC-RR1U-E16	①	x16 HHHL

Full-height = 4.2", Low-profile = 2.5", Full-length = 10.5", Half-length = 6.6"

Before following the procedure below to install expansion cards, first turn off and remove power from the system as described in [section 3.1](#) then remove the top cover.

Installing Expansion Cards

1. Remove any slimline SAS cables connected to the riser card and pull up the riser card brackets.
 - For the right side (looking from the node rear), open the clip of each slot on the right.
 - For the left side, open the clip of each slot.
2. Remove the blank PCI shield from the chassis.
3. Slide the expansion card shield into the open shield slot while plugging the expansion card into the riser card.

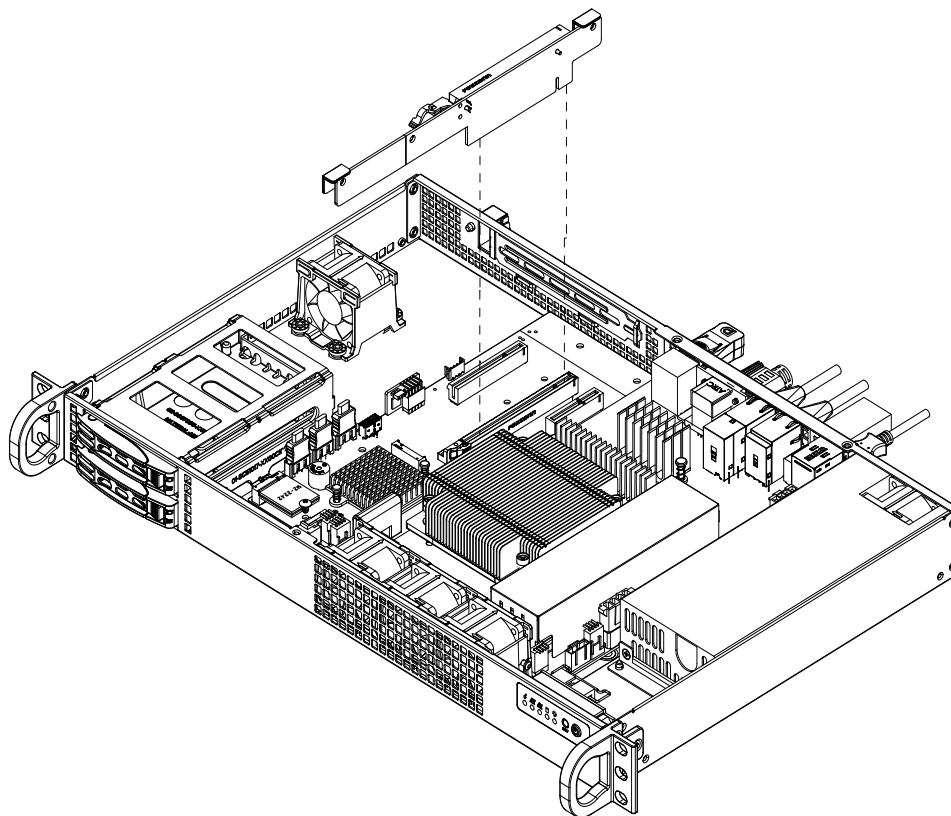

Figure 3-13. Installing Expansion Cards

3.10 Power Supply

The system includes two hot-plug power supply modules. These modules will automatically sense and operate at an input voltage between 100V to 240V. Note that different input voltages will result in different maximum power output levels.

In the event of a power module failure, the other power module will continue to power the system on its own. Failed power supply modules can be replaced without powering down the system. Replacement modules can be ordered directly from Supermicro.

An amber light on the power supply is illuminated when the power is switched off. A green light indicates that the power supply is operating.

Removing the Power Supply

If the power is on, removing power from the system as described in Section 3.1.

1. Disconnect all wiring from the power supply.
2. Remove the four screws which hold the power supply in the chassis. The two rear mounting screws are located at the rear of the chassis. The two mid-chassis mounting screws are accessed from the underside and extend upwards through the chassis. Set the screws aside for later use.
3. Remove the power supply from the chassis.

Installing a Power Supply

1. Replace the failed power supply with another identical power supply module.
2. Align the mounting thru holes on the power supply with the mounting holes in the chassis and reattach the power supply to the chassis using the four screws which were previously set aside.
3. Connect the chassis wiring to the power supply.
4. Reattach the AC power cord and power on the system.

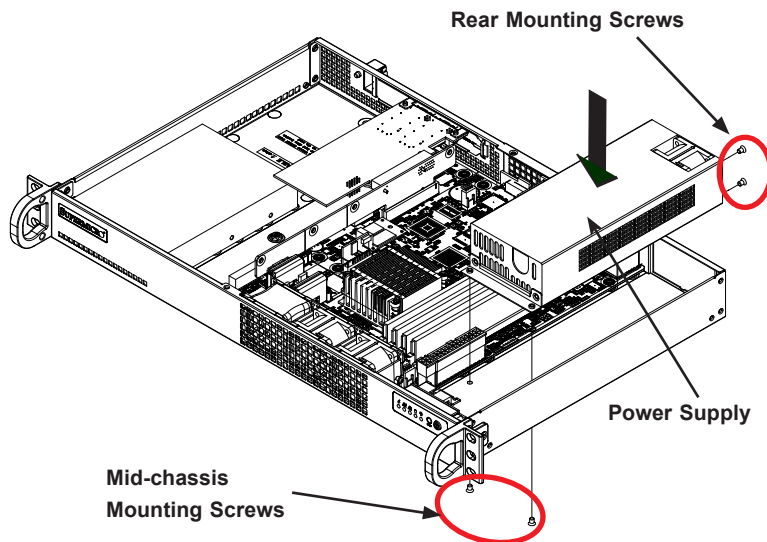

Figure 3-14. Removing/Replacing a Power Supply

3.11 BMC

The BMC can be reset using the button on the front control panel or on the chassis rear.

- **Reset**—Press and hold the button. After six seconds, the LED blinks at 2 Hz. The BMC resets and the reset duration is ~250 ms. Then the BMC starts to boot.
- **Restore factory default configuration**—Hold the button for twelve seconds. The LED blinks at 4 Hz while defaults are configured.
- **Firmware update**—the UID LED blinks at 10Hz during a firmware update.

BMC Reset Options	
Event	LED (Green)
Reset	Blinks at 2 Hz
Restore Defaults	Blinks at 4 Hz
Update	Blinks at 10 Hz

Chapter 4

Motherboard Connections

This section describes the connections on the motherboard and provides pinout definitions. Note that depending on how the system is configured, not all connections are required. The LEDs on the motherboard are also described here. A motherboard layout indicating component locations may be found in [Chapter 1](#). More detail can be found in the [Motherboard Manual](#). Please review the Safety Precautions in [Appendix A](#) before installing or removing components.

4.1 Power Connections

ATX Power Supply Connector

The 24-pin power supply connector (JPW1) meets the ATX SSI EPS 12V specification. You must also connect the 8-pin (JPV1) processor power connector to the power supply.

ATX Power 24-pin Connector Pin Definitions			
Pin#	Definition	Pin#	Definition
13	+3.3V	1	+3.3V
14	-12V	2	+3.3V
15	Ground	3	Ground
16	PS_ON	4	+5V
17	Ground	5	Ground
18	Ground	6	+5V
19	Ground	7	Ground
20	Res (NC)	8	PWR_OK
21	+5V	9	5VSB
22	+5V	10	+12V
23	+5V	11	+12V
24	Ground	12	+3.3V

Required Connection

8-Pin Power Connector

JPV1 is an 8-pin 12V DC power input for CPU or alternative single power source for a special enclosure when the 24-pin ATX power is not in use. Refer to the table below for pin definitions.

8-pin Power Pin Definitions	
Pin#	Definition
1 - 4	Ground
5 - 8	P12V (12V Power)

Required Connection

4-pin 12V Power Connector

JPWR1 is a 4-pin connector that provides 12V DC power (up to 75W) from the motherboard for a GPU add-on card or various peripherals. Please keep the power usage for JPWR1 within the power limits of up to 75W. Overcurrent DC power usage may cause damage to the motherboard. Refer to the table below for pin definitions.

4-pin Power Pin Definitions	
Pin#	Definition
1 - 2	Ground
3 - 4	+12V

4-pin HDD Power Connector

JPH1 is a 4-pin power connector that provides power to onboard HDD devices. Refer to the table below for pin definitions.

4-pin HDD Power Pin Definitions	
Pin#	Definition
1	12V
2	GND
3	GND
4	5V

4.2 Headers and Connectors

Fan Headers

There are six 4-pin fan headers (FAN1 ~ FAN4, FANA1 and FANB1) on the motherboard. All these 4-pin fan headers are backwards compatible with the traditional 3-pin fans. However, fan speed control is available for 4-pin fans only by Thermal Management via the IPMI 2.0 interface. Refer to the table below for pin definitions.

Fan Header Pin Definitions	
Pin#	Definition
1	Ground (Black)
2	2.5A/+12V (Red)
3	Tachometer
4	PWM_Control

SGPIO Headers

There is one Serial Link General Purpose Input/Output (I-SGPIO1) header located on the motherboard. I-SGPIO is for SATA use. Refer to the tables below for pin definitions.

SGPIO Header Pin Definitions			
Pin#	Definition	Pin#	Definition
1	NC	2	NC
3	Ground	4	Data
5	Load	6	Ground
7	Clock	8	NC

NC = No Connection

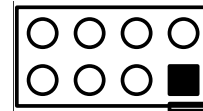

Pin 8	Pin 6	Pin 4	Pin 2
Pin 7	Pin 5	Pin 3	Pin 1

Disk-On-Module Power Connector

One power connector for SATA DOM (Disk-On-Module) devices is located at JSD1. Connect appropriate cables here to provide power support for your Serial Link DOM devices.

DOM Power Pin Definitions	
Pin#	Definition
1	5V
2	Ground
3	Ground

General Purpose I/O Header

The JGP1 (General Purpose Input/Output) header is a general purpose I/O expander on a pin header via the SMBus. Refer to the table below for pin definitions.

General Purpose I/O Header Pin Definitions			
Pin#	Definition	Pin#	Definition
1	NC	2	GND
3	JGP1_0	4	JGP1_1
5	JGP1_2	6	JGP1_3
7	JGP1_4	8	JGP1_5
9	JGP1_6	10	JGP1_7

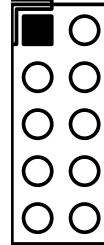

Pin 1	Pin 2
Pin 3	Pin 4
Pin 5	Pin 6
Pin 7	Pin 8
Pin 9	Pin 10

TPM/Port 80 Header

A Trusted Platform Module (TPM)/Port 80 header is located at JTPM1 to provide TPM support and Port 80 connection. Use this header to enhance system performance and data security. Refer to the table below for pin definitions. Please go to the following link for more information on the TPM: <http://www.supermicro.com/manuals/other/TPM.pdf>.

Trusted Platform Module Header Pin Definitions			
Pin#	Definition	Pin#	Definition
1	+3.3V	2	SPI_CS#
3	RESET#	4	SPI_MISO
5	SPI_CLK	6	GND
7	SPI_MOSI	8	NC
9	+3.3V Stdby	10	SPI_IRQ#

System Management Bus Header

A System Management Bus header for additional slave devices or sensors is located at JSMB1. Refer to the table below for pin definitions.

SMBus Header Pin Definitions	
Pin#	Definition
1	Data
2	Ground
3	Clock

Power SMB (I²C) Header

The Power System Management Bus (I²C) connector (JPI²C1) monitors the power supply, fan, and system temperatures. Refer to the table below for pin definitions.

Power SMB Header Pin Definitions	
Pin#	Definition
1	Clock
2	Data
3	PMBUS_Alert
4	Ground
5	+3.3V

4-pin BMC External I²C Header

A System Management Bus header for IPMI 2.0 is located at JIPMB1. Connect the appropriate cable here to use the IPMB I²C connection on your system. Refer to the table below for pin definitions.

External I ² C Header Pin Definitions	
Pin#	Definition
1	Data
2	Ground
3	Clock
4	No Connection

Chassis Intrusion

A Chassis Intrusion header is located at JL1 on the motherboard. Attach the appropriate cable from the chassis to inform you of a chassis intrusion when the chassis is opened. Refer to the table below for pin definitions.

Chassis Intrusion Pin Definitions	
Pin#	Definition
1	Intrusion Input
2	Ground

Speaker/Buzzer

On the JD1 header, pins 1-4 are for the speaker and pins 3-4 are for the buzzer. If you wish to use an external speaker, connect its cable to pins 1-4.

Speaker Connector Pin Definitions	
Pin #	Definition
1-4	Speaker
3-4	Buzzer

Internal Speaker/Buzzer

The Internal Speaker/Buzzer (SP1) is used to provide audible indications for various beep codes. Refer to the table below for pin definitions.

Internal Buzzer Pin Definitions		
Pin#	Definition	
1	Pos (+)	Beep In
2	Neg (-)	Alarm Speaker

Extended CMOS Battery Connector

J18 is a power connector that provides additional power to maintain the CMOS data with an external battery. Refer to the table below for pin definitions.

CMOS Battery Connector Pin Definitions	
Pin#	Definition
1	VBAT
2	Ground

Required Connection

M.2 M-Key Temperature Sensor

ART1 is the M-Key temperature sensor.

COM Header

The motherboard has one COM header that provides two serial connections (COM1/2) and supports RS-232 function, utilizing Supermicro PN: CBL-CDAT-0604 (not included).

COM Header (COM1/2) Pin Definitions			
Pin#	Definition	Pin#	Definition
1	DCD3	2	DSR3
3	RXD3	4	RTS3
5	TXD3	6	CTS3
7	DTR3	8	RI3_N
9	GND	10	N/A
11	DCD4	12	DSR4
13	RXD4	14	RTS4
15	TXD4	16	CTS4
17	DTR4	18	RI4_N
19	GND	20	N/A

Control Panel

JF1 contains header pins for various buttons and indicators that are normally located on a control panel at the front of the chassis. These connectors are designed specifically for use with Supermicro chassis. See the figure below for the descriptions of the front control panel buttons and LED indicators.

Power Button

The Power Button connection is located on pins 1 and 2 of JF1. Momentarily contacting both pins will power on/off the system. This button can also be configured to function as a suspend button (with a setting in the BIOS - see Chapter 4). To turn off the power when the system is in suspend mode, press the button for four seconds or longer. Refer to the table below for pin definitions.

Power Button Pin Definitions (JF1)	
Pin#	Definition
1	Signal
2	Ground

Reset Button

The Reset Button connection is located on pins 3 and 4 of JF1. Attach it to a hardware reset switch on the computer case to reset the system. Refer to the table below for pin definitions.

Reset Button Pin Definitions (JF1)	
Pin#	Definition
3	Reset
4	Ground

Power Fail LED

The Power Fail LED connection is located on pins 5 and 6 of JF1. Refer to the table below for pin definitions.

Power Fail LED Pin Definitions (JF1)	
Pin#	Definition
5	3.3V
6	Power Fail LED

Overheat (OH)/Fan Fail

Connect an LED cable to pins 7 and 8 of the Front Control Panel to use the Overheat/Fan Fail LED connections. The LED on pin 8 provides warnings of overheating or fan failure. Refer to the tables below for pin definitions.

OH/Fan Fail Indicator Status	
State	Definition
Off	Normal
On	Overheat
Flashing	Fan Fail

OH/Fan Fail LED Pin Definitions (JF1)	
Pin#	Definition
7	Blue UID LED
8	OH/Fan Fail LED

NIC1/NIC2 (LAN1/LAN2)

The NIC (Network Interface Controller) LED connection for LAN port 1 is located on pins 11 and 12 of JF1, and LAN port 2 is on pins 9 and 10. Attach the NIC LED cables here to display network activity. Refer to the table below for pin definitions.

NIC1/NIC2 LED Pin Definitions (JF1)	
Pin#	Definition
9	NIC 2 Activity LED
10	NIC 2 Link LED
11	NIC 1 Activity LED
12	NIC 1 Link LED

HDD LED

The HDD LED connection is located on pins 13 and 14 of JF1. Attach a cable to pin 14 to show hard drive activity status. Refer to the table below for pin definitions.

HDD LED Pin Definitions (JF1)	
Pins	Definition
13	3.3V Stdby
14	HDD Active

Power LED

The Power LED connection is located on pins 15 and 16 of JF1. Refer to the table below for pin definitions.

Power LED Pin Definitions (JF1)	
Pins	Definition
15	3.3 Stby
16	PWR LED

NMI Button

The non-maskable interrupt (NMI) button header is located on pins 19 and 20 of JF1. Refer to the table below for pin definitions.

NMI Button Pin Definitions (JF1)	
Pins	Definition
19	Control
20	Ground

4.3 Input/Output Ports

I/O Ports

See below figure for the locations and descriptions of the various I/O ports on the rear of the motherboard.

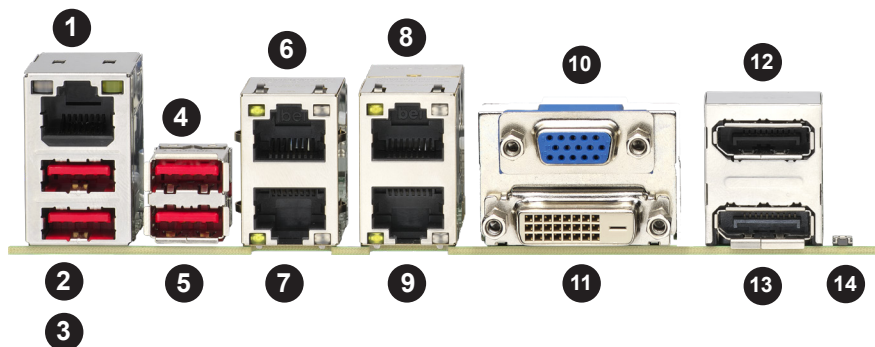

Rear I/O Ports					
#	Description	#	Description	#	Description
1	IPMI LAN	6	LAN2	11	DVI-D
2	USB9 (3.2)	7	LAN1	12	DisplayPort 2
3	USB8 (3.2)	8	LAN4	13	DisplayPort 1
4	USB7 (3.2)	9	LAN3	14	UID Switch
5	USB6 (3.2)	10	VGA		

VGA/DVI-D Port

A VGA port and a DVI-D port are located next to DisplayPorts 1/2 on the I/O back panel. Use these connections for VGA and DVI displays. The VGA connector is on top and the DVI-D is on the bottom.

DP++ (DisplayPort)

There are two DisplayPorts located on the rear I/O back panel. DisplayPort, developed by the VESA consortium, delivers digital display and fast refresh rate. It can connect to virtually any display using a DisplayPort adaptor for devices such as VGA, DVI, or HDMI.

LAN Ports

Two Gigabit (JLAN1/2) and two 10 Gigabit Ethernet ports are located on the I/O back panel. In addition, a dedicated IPMI LAN is located above the USB8/9 ports on the back panel. All of these ports accept RJ45 cables. Please refer to the LED Indicator section for LAN LED information.

LAN Port Pin Definition			
Pin#	Definition	Pin#	Definition
1	TRCT2	13	IETCT
2	TRD2+	14	IET+
3	TRD2-	15	IET-
4	TRD3+	16	
5	TRD3-	17	L1-GRE-
6	TRCT3	18	L1-GRE+
7	TRCT1	19	L2-YEL-
8	TRD1+	20	COMMON
9	TRD1-	21	L2-GRE-
10	TRD4+	22	CG1
11	TRD4-	23	CG2
12	TRCT4		

IPMI LAN Pin Definition			
Pin#	Definition	Pin#	Definition
9	VCC	19	YEL-
10	TX1+	20	YEL+
11	TX1-	21	ORG+/GRN-
12	TX2+	22	ORG-/GRN+
13	TX2-	23	SGND
14	TX3+	24	SGND
15	TX3-	25	SGND
16	TX4+	26	SGND
17	TX4-		
18	GND		

Universal Serial Bus (USB) Ports

There are four USB 3.2 (10Gb) ports (USB6/7 and USB8/9) located on the I/O back panel. The motherboard also has six front access USB 2.0 headers (USB0/1, USB2/3, and USB4/5). The USB10/11 header is USB 3.2 (10Gb) Type-A. The onboard headers can be used to provide front side USB access with a cable (not included). Pin definition tables for USB ports and headers are on this page and the next.

Front Panel USB 0/1, 2/3, 4/5 (2.0) Pin Definitions			
Pin#	Definition	Pin#	Definition
1	+5V	2	+5V
3	USB_N	4	USB_N
5	USB_P	6	USB_P
7	Ground	8	Ground
9	Key	10	NC

Back Panel USB 6/7, 8/9 (3.2) Pin Definitions			
Pin#	Definition	Pin#	Definition
A1	VBUS	B1	Power
A2	D-	B2	USB_N
A3	D+	B3	USB_P
A4	GND	B4	GND
A5	Stda_SSRX-	B5	USB3_RN
A6	Stda_SSRX+	B6	USB3_RP
A7	GND	B7	GND
A8	Stda_SSTX-	B8	USB3_TN
A9	Stda_SSTX+	B9	USB3_TP

Universal Serial Bus (USB) Ports (continued)

Front Panel Type A USB 10/11 (3.2) Pin Definitions			
Pin#	Definition	Pin#	Definition
1	GND	11	GND
2	SS_TX_P5_CON	12	SS_TX_N6_CON
3	SS_TX_N5_CON	13	SS_TX_P6_CON
4	GND	14	GND
5	SS_RX_P5_CON	15	SS_RX_N6_CON
6	SS_RX_N5_CON	16	SS_RX_P6_CON
7	GND	17	GND
8	USB_CON_P6	18	USB_CON_P5
9	USB_CON_N6	19	USB_CON_N5
10	VBUS	20	VBUS

Unit Identifier Switch/UID LED Indicator

A Unit Identifier (UID) switch and an LED Indicator are located on the motherboard. The UID switch is located at UID SW, which is next to the Display Port on the back panel. The UID LED is located next to the UID switch. When you press the UID switch, the UID LED will be turned on. Press the UID switch again to turn off the LED indicator. The UID Indicator provides easy identification of a system unit that may be in need of service.

Note: UID can also be triggered via IPMI on the motherboard. For more information on IPMI, please refer to the IPMI User's Guide posted on our website at <https://www.supermicro.com/support/manuals/>.

UID Switch Pin Definitions	
Pin#	Definition
1	Ground
2	Ground
3	Button In
4	Button In

UID LED Pin Definitions	
Color	Status
Blue: On	Unit Identified

4.4 Jumpers

Explanation of Jumpers

To modify the operation of the motherboard, jumpers can be used to choose between optional settings. Jumpers create shorts between two pins to change the function of the connector. Pin 1 is identified with a square solder pad on the printed circuit board. See the diagram below for an example of jumping pins 1 and 2. Refer to the motherboard layout page for jumper locations.

Note: On two-pin jumpers, "Closed" means the jumper is on, and "Open" means the jumper is off the pins.

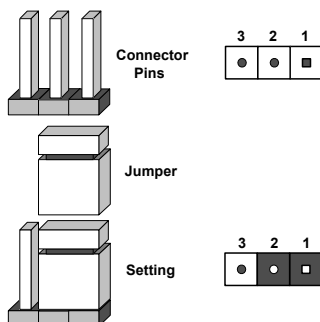

CMOS Clear

JBT1 is used to clear CMOS, which will also clear any passwords. Instead of pins, this jumper consists of contact pads to prevent accidentally clearing the contents of CMOS.

To Clear CMOS

1. First power down the system and unplug the power cord(s).
2. Remove the cover of the chassis to access the motherboard.
3. Remove the onboard battery from the motherboard.
4. Short the CMOS pads with a metal object such as a small screwdriver for at least four seconds.
5. Remove the screwdriver (or shorting device), and reinstall the battery to the proper location
6. Replace the cover, reconnect the power cord(s), and power on the system.

Note: Clearing CMOS will also clear all passwords. Do not use the PW_ON connector to clear CMOS.

Watch Dog Time

Watchdog (JWD1) is a system monitor that can reboot the system when a software application hangs. Close pins 1-2 to reset the system if an application hangs. Close pins 2-3 to generate a non-maskable interrupt (NMI) signal for the application that hangs. Refer to the table below for jumper settings. The Watchdog must also be enabled in the BIOS.

Watch Dog Jumper Settings	
Jumper Setting	Definition
Pins 1-2	Reset
Pins 2-3	NMI
Open	Disabled

VGA Enable/Disable

Jumper JPG1 allows the user to enable the onboard VGA connector. The default setting is pins 1-2 to enable the connection. Refer to the table below for jumper settings.

VGA Enable/Disable Jumper Settings	
Jumper Setting	Definition
Pins 1-2	Enabled
Pins 2-3	Disabled

LAN1/LAN2 Enable/Disable

Use jumper JPL1 to enable or disable LAN port 1 and JPL2 to enable or disable LAN port 2.

LAN1/2 Enable/Disable Jumper Settings	
Jumper Setting	Definition
Pins 1-2	Enabled (Default)
Pins 2-3	Disabled

LAN3/LAN4 Enable/Disable

Use jumper JPTG1 to enable or disable LAN ports 3 and 4.

LAN3/4 Enable/Disable Jumper Settings	
Jumper Setting	Definition
Pins 1-2	Enabled (Default)
Pins 2-3	Disabled

Front Panel Audio Enable

JPAC1 allows you to enable or disable the onboard audio support. The default position is on pins 1 and 2 to enable onboard audio connections. Refer to the table below for jumper settings.

Front Panel Audio Enable Jumper Settings	
Jumper Setting	Definition
Pins 1-2	Enabled (Default)
Pins 2-3	Disabled

ME Manufacturing Mode

Close pins 2-3 of jumper JPME2 to bypass SPI flash security and force the system to operate in the manufacturing mode, which will allow the user to flash the system firmware from a host server for system setting modifications. Refer to the table below for jumper settings.

ME Manufacturing Mode Jumper Settings	
Jumper Setting	Definition
Pins 1-2	Normal (Default)
Pins 2-3	Manufacturing Mode

IPMI Share LAN Feature

Set the JBM1 jumper to enable or disable IPMI shared access on LAN1 (Intel I210-AT).

IPMI Share LAN Enable/Disable Jumper Settings	
Jumper Setting	Definition
Pins 1-2 (Open)	Enabled (Default)
Pins 1-2 (Short)	Disabled

IPMI LAN Enable/Disable

Use JBM2 to enable or disable IPMI remote access. Refer to the table below for jumper settings.

IPMI LAN Enable/Disable Jumper Settings	
Jumper Setting	Definition
Pins 1-3 (Short)	Enabled (Default)
Pins 1-2 (Short)	Disabled

Slot6 PCIe Bifurcation Option

Set the JRF1 jumper to set Slot 6's PCIe lanes to either x16 or x8x8.

PCIe Bifurcation Jumper Settings	
Jumper Setting	Definition
Pins 1-2	x16 (Default)
Pins 2-3	x8x8

LAN3/LAN4 Power Option

Use J10G_PWR jumper to set the power option for LAN3 and LAN4 (Intel X550).

LAN3/LAN4 Power Jumper Settings	
Jumper Setting	Definition
Pins 1-2	Standby Power (Default)
Pins 2-3	Normal Power

TPM Enable

Use JPT1 to enable or disable the onboard TPM 2.0. Refer to the table below for jumper settings.

TPM Enable/Disable Jumper Settings	
Jumper Setting	Definition
Pins 1-2	Enabled
Pins 2-3	Disabled (Default)

4.5 LED Indicators

LAN LEDs

Four LAN ports (JLAN 1/2 and JLAN 3/4) are located on the I/O back panel of the motherboard. Each Ethernet LAN port has two LEDs. The green LED indicates activity, while the other Link LED may be green, amber, or off to indicate the speed of the connection. Refer to the tables below for more information.

LAN Activity LED (Right) LED State		
Color	Status	Definition
Green	Flashing	Active

LAN Link LED (Left) LED State	
LED Color	Definition
Green	10Gbps
Yellow/Amber	1Gbps

IPMI LAN LEDs

In addition to the four LAN ports, an IPMI LAN is also located on the I/O back panel. The amber LED on the right indicates activity, while the green LED on the left indicates the speed of the connection. Refer to the table below for more information.

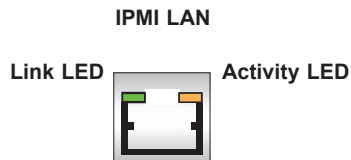

IPMI LAN LEDs		
	Color/State	Definition
Link (left)	Green: Solid	100 Mbps
	Amber: Solid	1Gbps
Activity (Right)	Amber: Blinking	Active

Power LED

LED1 is the Power LED. When this LED is lit, it means power is present on the motherboard. In suspend mode, this LED will blink on and off. Be sure to turn off the system and unplug the power cord(s) before removing or installing components.

Power LED Indicator	
LED Color	Definition
Off	System Off (power cable not connected)
Green	System On

BMC Heartbeat LED

BMC_HB_LED1 is the BMC heartbeat LED. When the LED is blinking green, BMC is functioning normally. Refer to the table below for the LED status.

BMC Heartbeat LED Indicator	
LED Color	Definition
Green: Blinking	BMC Normal

4.6 Storage Ports

SATA Ports

Four SATA 3.0 ports are located on the motherboard supported by the Intel W480/Q470 chipset. These SATA ports support RAID 0, 1, 5, and 10.

Note: For more information on the SATA HostRAID configuration, please refer to the Intel SATA HostRAID user's guide posted on our website at <https://www.supermicro.com/support/manuals/>.

M.2 Slot

The motherboard has two M.2 slots (JMD1 and JMD2). M.2 was formerly known as Next Generation Form Factor (NGFF) and serves to replace mini PCIe. M.2 allows for a variety of card sizes, increased functionality, and spatial efficiency. JMD1 supports an E-Key CNVi/PCIe 3.0 x1 device in the 2230 form factor, whereas JMD2 supports an M-Key SATA/PCIe 3.0 x4 device in the 2280 and 22110 form factors.

Chapter 5

Software

After the hardware has been installed, you can install the Operating System (OS), configure RAID settings, and install the drivers.

5.1 Microsoft Windows OS Installation

If you will be using RAID, you must configure RAID settings before installing the Windows OS and the RAID driver. Refer to the RAID Configuration User Guides posted on our website at www.supernmicro.com/support/manuals.

Installing the OS

1. Create a method to access the MS Windows installation ISO file. That might be a USB flash or media drive or the IPMI KVM console.
2. Retrieve the proper RST/RSTe driver. Go to the Supermicro web page for your motherboard and click on "Download the Latest Drivers and Utilities", select the proper driver, and copy it to a USB flash drive.
3. Boot from a bootable device with Windows OS installation. You can see a bootable device list by pressing **F11** during the system startup.

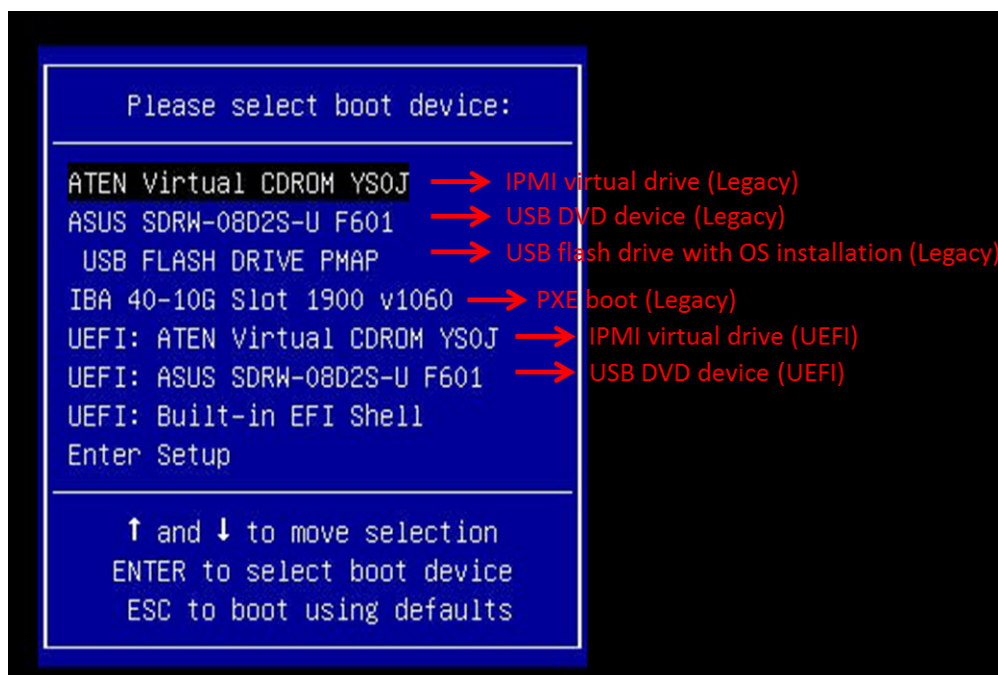

Figure 5-1. Select Boot Device

4. During Windows Setup, continue to the dialog where you select the drives on which to install Windows. If the disk you want to use is not listed, click on “Load driver” link at the bottom left corner.

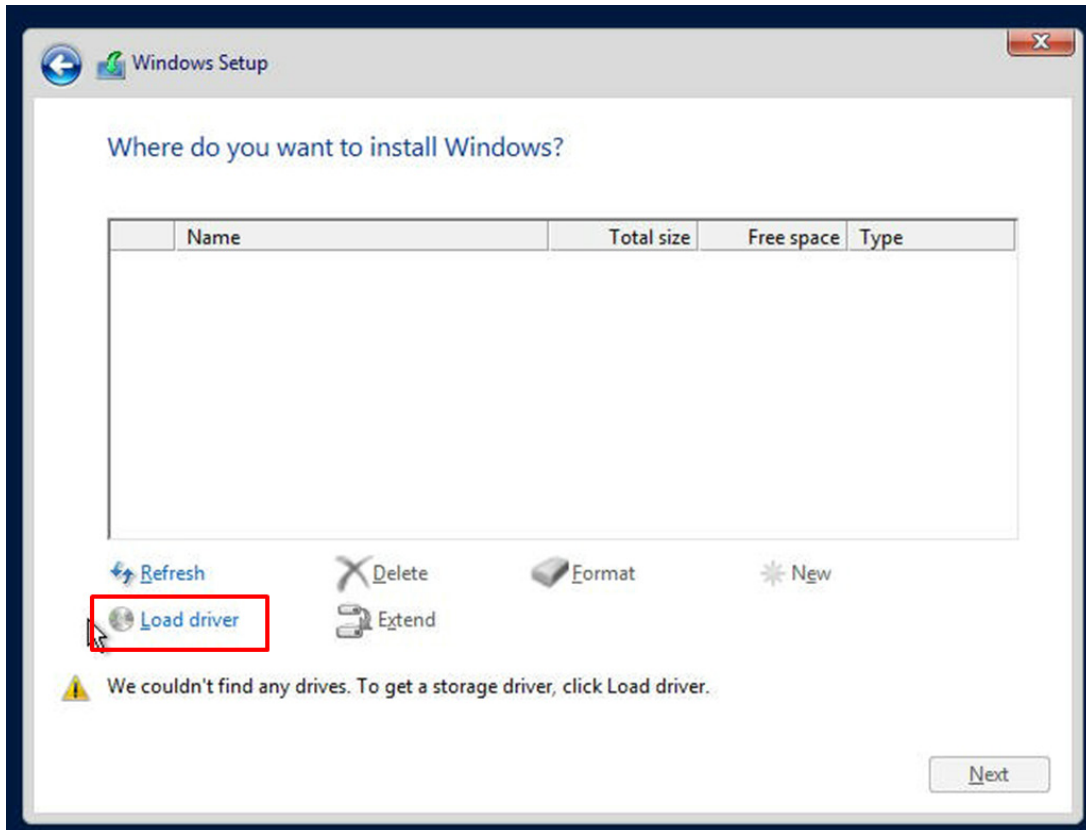

Figure 5-2. Load Driver Link

To load the driver, browse the USB flash drive for the proper driver files.

- For RAID, choose the SATA/sSATA RAID driver indicated then choose the storage drive on which you want to install it.
 - For non-RAID, choose the SATA/sSATA AHCI driver indicated then choose the storage drive on which you want to install it.
5. Once all devices are specified, continue with the installation.
 6. After the Windows OS installation has been completed, the system will automatically reboot multiple times.

5.2 Driver Installation

The Supermicro website contains drivers and utilities for your system at <https://www.supermicro.com/wdl/driver>. Some of these must be installed, such as the chipset driver.

After accessing the website, go into the CDR_Images (in the parent directory of the above link) and locate the ISO file for your motherboard. Download this file to a USB flash or media drive. (You may also use a utility to extract the ISO file if preferred.)

Another option is to go to the Supermicro website at <http://www.supermicro.com/products/>. Find the product page for your motherboard, and "Download the Latest Drivers and Utilities". Insert the flash drive or disk, and the screenshot shown below should appear.



Figure 5-3. Driver and Tool Installation Screen

Note: Click the icons showing handwriting on paper to view the readme files for each item. Click the computer icons to the right of these items to install each item (from top to the bottom) one at a time. **After installing each item, you must reboot the system before moving on to the next item on the list.** The bottom icon with a CD on it allows you to view the entire content.

5.3 SuperDoctor® 5

The Supermicro SuperDoctor 5 is a program that functions in a command-line or web-based interface for Windows and Linux operating systems. The program monitors such system health information as CPU temperature, system voltages, system power consumption, fan speed, and provides alerts via email or Simple Network Management Protocol (SNMP).

SuperDoctor 5 comes in local and remote management versions and can be used with Nagios to maximize your system monitoring needs. With SuperDoctor 5 Management Server (SSM Server) IPMI, you can remotely control power ON/OFF and reset chassis intrusion for multiple systems. SuperDoctor 5 Management Server monitors HTTP, FTP, and SMTP services to optimize the efficiency of your operation.

[SuperDoctor® Manual and Resources](#)

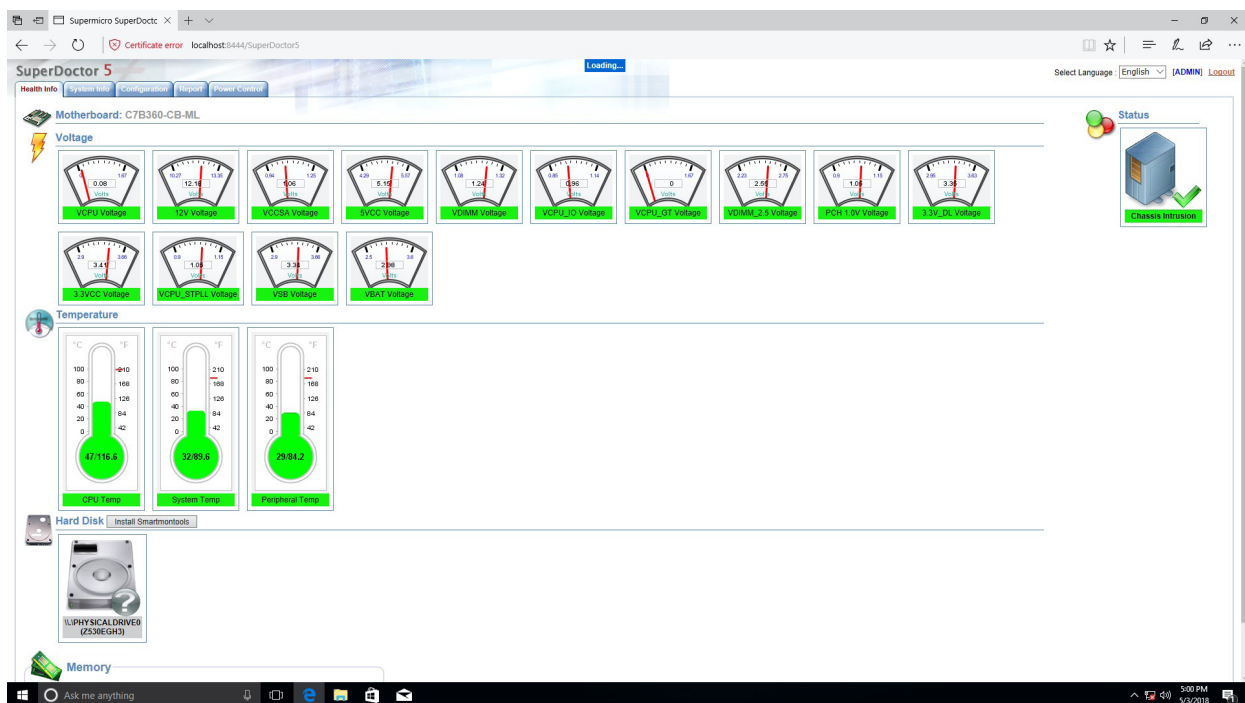

Figure 5-4. SuperDoctor 5 Interface Display Screen (Health Information)

5.4 IPMI

The motherboard provides the Intelligent Platform Management Interface (IPMI). IPMI provides remote access, monitoring and management through the baseboard management controller (BMC) and other management controllers distributed among different system modules. There are several BIOS settings that are related to IPMI. For general documentation and information on IPMI, visit our website at: www.supermicro.com/products/info/IPMI.cfm.

BMC ADMIN User Password

For security, each system is assigned a unique default BMC password for the ADMIN user. This can be found on a sticker on the chassis and a sticker on the motherboard. The sticker also displays the BMC MAC address. If necessary, the password can be reset using the Supermicro IPMICFG tool.



Figure 5-5. BMC Password Label

The sticker can be found on the pull-out service tag at the front of the chassis. See [Chapter 1](#) for label location.

Chapter 6

Optional Components

This chapter describes alternate configurations and optional system components.

Optional Parts
Storage drive options
Cable Management Arm
TPM security module
Intel VROC RAID Key

6.1 Storage Drive Options

The storage drive bays can support SATA, and SAS in any combination. To enable SAS, an additional hardware is required. Once the supporting hardware is installed for a selection of bays, drives of any storage protocol type can be inserted.

SAS – The system can support four SAS drives with one of the supported add-on storage controller card.

6.2 Cable Management Arm

The system supports a cable management arm (CMA), which keeps the rear cables organized and clear of the rail mechanisms when the system is extended out the front of the rack for maintenance.

The CMA attaches to the rack mounting rails using four connectors. They are labeled on the connectors 1, 2, 3, and 4.

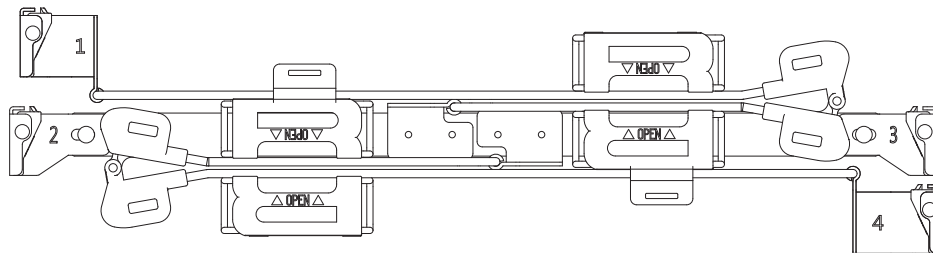

Figure 3-1. Cable Management Arm

Installing the Cable Management Arm

1. Slide CMA connector #1 forward onto the two posts on the rear of the right *inner* rail (right side when viewed from the front). It snaps into place.
2. Slide CMA connector #2 forward onto the two posts on the rear of the right *middle* rail. It snaps into place.

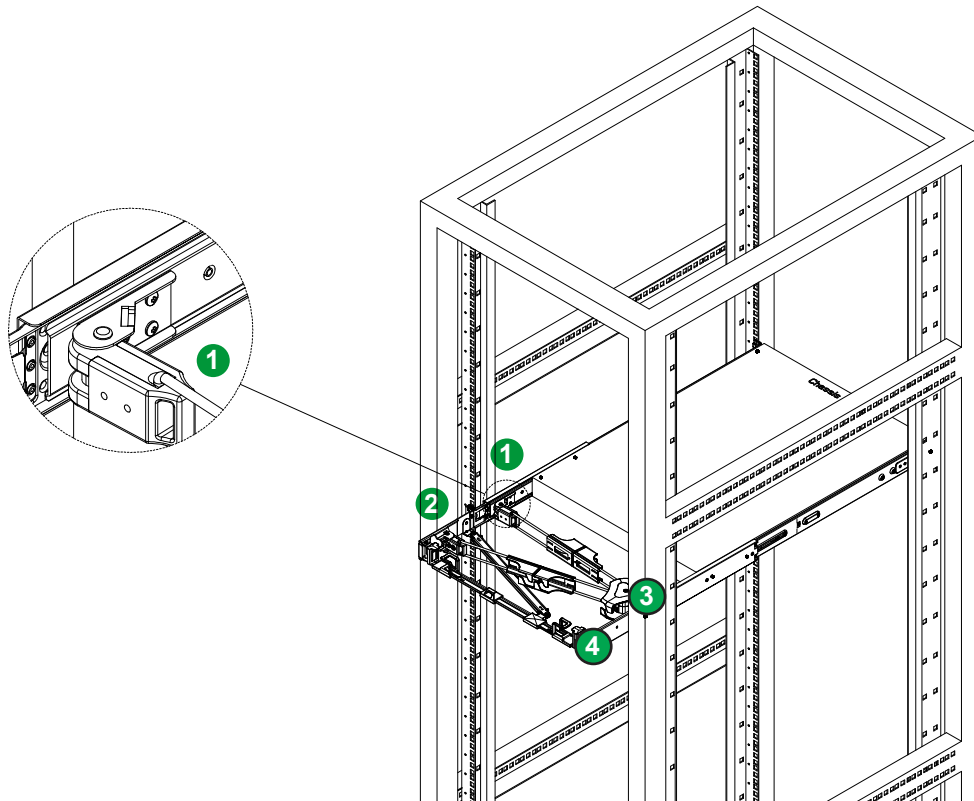

Figure 3-2. Installing the Connectors

3. Slide CMA connector #3 forward onto the two posts on the rear of the left middle rail. It snaps into place.
4. For CMA connector #4, align the metal tabs with the slots on the rear of the left outer rail and push it forward. It snaps into place.
5. Route the cables through the holding brackets, leaving enough slack.

Removing the Cable Management Arm

1. Remove cables from the CMA,
2. For CMA connector #4, pull the metal release tab toward the center of the rack and slide the connector toward the rear to release it.
3. For CMA connectors #3, #2, and #1, depress the front edge of the yellow plastic rocker lock and slide the connector toward the rear to release it.

6.3 TPM Security Module

SPI capable TPM 2.0 (or 1.2) with Infineon 9670 controller, vertical form factor

The JTPM1 header is used to connect a Trusted Platform Module (TPM). A TPM is a security device that supports encryption and authentication in hard drives. It enables the motherboard to deny access if the TPM associated with the hard drive is not installed in the system.

Details and installation procedures are at:

<http://www.supermicro.com/manuals/other/TPM.pdf>.

- AOM-TPM-9670V
- AOM-TPM-9671V

Chapter 7

Troubleshooting and Support

7.1 Information Resources

Website

A great deal of information is available on the Supermicro website, supermicro.com.

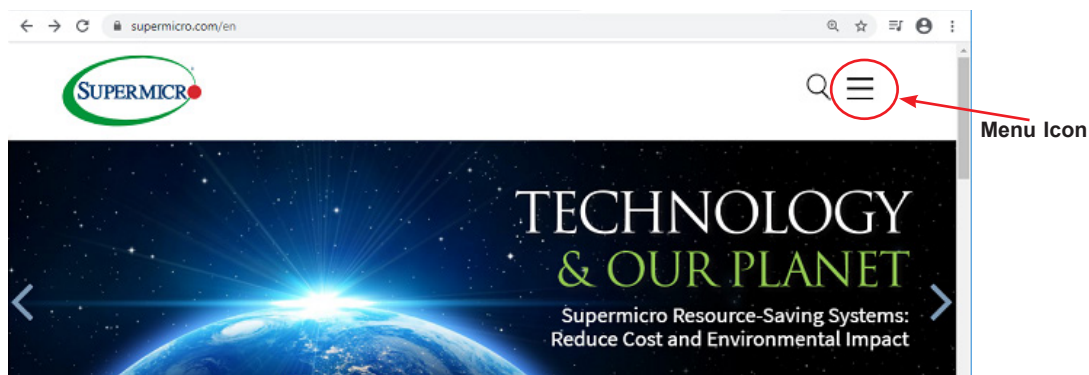

Figure 7-1. Supermicro Website

- Specifications for servers and other hardware are available by clicking the menu icon, then selecting the **Products** option.
- The **Support** option offers downloads (manuals, BIOS/BMC, drivers, etc.), FAQs, RMA, warranty, and other service extensions.

Direct Links for the SYS-110C-FHN4T System

[SYS-SYS-110C-FHN4T](#) specifications page

[X12SCZ-TLN4F motherboard page](#) for links to the Quick Reference Guide, User Manual, validated storage drives, etc.

Direct Links for General Support and Information

[Frequently Asked Questions](#)

[TPM User Guide](#)

General Memory Configuration Guide: [X12](#)

[SuperDoctor5 Large Deployment Guide](#)

For validated memory, see our [Product Resources page](#)

Direct Links (continued)

[IPMI User Guide](#)

[Product Matrices](#) page for links to tables summarizing specs for systems, motherboards, power supplies, riser cards, add-on cards, etc.

[Security Center](#) for recent security notices

[Supermicro Phone and Addresses](#)

7.2 Intelligent Platform Management Interface (IPMI)

The system supports the Intelligent Platform Management Interface (IPMI). IPMI is used to provide remote access, monitoring, and management. There are several BIOS settings that are related to IPMI.

For general documentation and information on IPMI, please visit our website at: <https://www.supermicro.com/products/nfo/IPMI.cfm>.

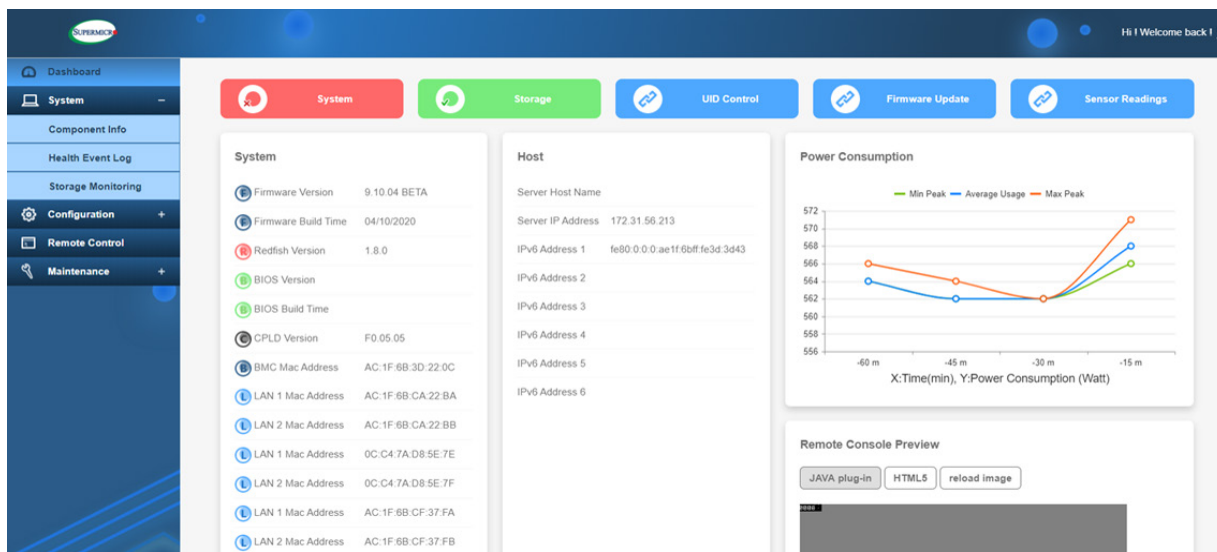

Figure 7-2. IPMI Sample

7.3 Troubleshooting Procedures

Use the following procedures to troubleshoot your system. If you have followed all of the procedures below and still need assistance, refer to the [Technical Support Procedures](#) or [Returning Merchandise for Service](#) section(s) in this chapter. [Power down](#) the system before changing any non-hot-swap hardware components.

No Power

1. Check that the power LED on the motherboard is ON.
2. Make sure that the power connector is connected to your power supply.

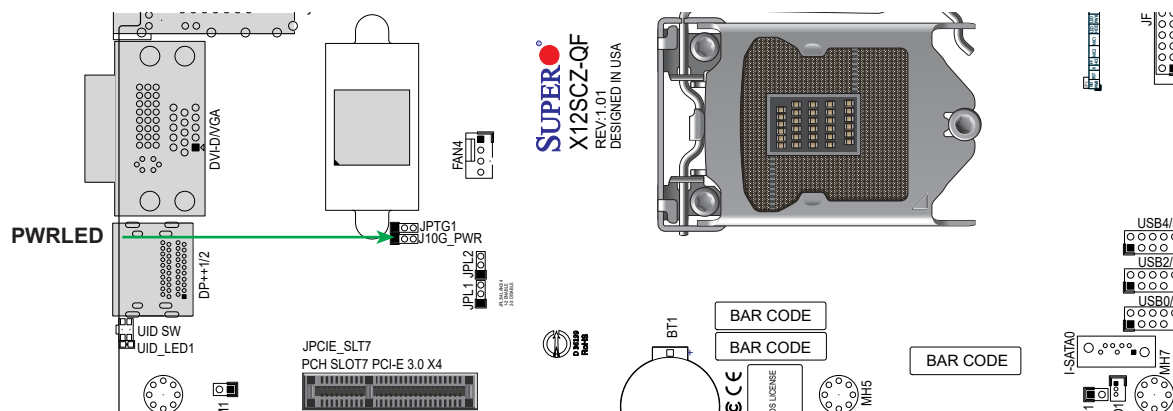

Figure 7-3. Location of the MB Power LED

3. Make sure that no short circuits exist between the motherboard and chassis.
4. Disconnect all cables from the motherboard, including those for the keyboard and mouse.
5. Remove all add-on cards.
6. Install a CPU, a heatsink, connect the internal speaker (if applicable), and the power LED to the motherboard. Make sure that the heatsink is fully seated.
7. Use the correct type of onboard CMOS battery as recommended by the manufacturer. Check to verify that it still supplies approximately 3VDC. If it does not, replace it with a new one. **Important!** To avoid possible explosion, do not install the battery upside down.
8. Verify that all jumpers are set to their default positions.
9. Check that the power supplies' input voltage operates at 100-120V or 180-240V.
10. Turn the power switch ON and OFF to test the system.

No Video

1. If the power is ON but you have no video, remove all the add-on cards and cables.

System Boot Failure

If the system does not display POST (Power-On-Self-Test) or does not respond after the power is turned ON, check the following:

Turn ON the system with only one DIMM module installed. If the system boots, check for bad DIMM modules or slots by following the Memory Errors Troubleshooting procedure below.

Memory Errors

1. Make sure that the DIMM modules are properly and fully installed.
2. Confirm that you are using the correct memory. Also, it is recommended that you use the same memory type and speed for all DIMMs in the system. See [Section 3.5](#) for memory details.
3. Check for bad DIMM modules or slots by swapping modules between slots and noting the results.
4. Check the power supply voltage 115V/230V switch.

Losing the System's Setup Configuration

1. Always replace power supplies with the exact same model that came with the system. A poor quality power supply may cause the system to lose the CMOS setup configuration.
2. The battery on your motherboard may be old. Check to verify that it still supplies approximately 3VDC. If it does not, replace it with a new one.
3. If the above steps do not fix the setup configuration problem, contact your vendor for repairs.

When the System Becomes Unstable

If the system becomes unstable during or after OS installation, check the following:

1. CPU/BIOS support: Make sure that your CPU is supported and that you have the latest BIOS installed in your system.
2. Memory support: Make sure that the memory modules are supported by testing the modules using memtest86 or a similar utility.

Note: Refer to the product page on our website at <http://www.supermicro.com> for memory and CPU support and updates.

1. HDD support: Make sure that all hard disk drives (HDDs) work properly. Replace the bad HDDs with good ones.
2. System cooling: Check the system cooling to make sure that all heatsink fans and CPU/system fans, etc., work properly. Check the hardware monitoring settings in the IPMI to make sure that the CPU and system temperatures are within the normal range. Also, check the front panel Overheat LED and make sure that it is not on.
3. Adequate power supply: Make sure that the power supply provides adequate power to the system. Make sure that all power connectors are connected. Please refer to our website for more information on the minimum power requirements.
4. Proper software support: Make sure that the correct drivers are used.

If the system becomes unstable before or during OS installation, check the following:

1. Source of installation: Make sure that the devices used for installation are working properly, including boot devices such as CD.
2. Cable connection: Check to make sure that all cables are connected and working properly.
3. Using the minimum configuration for troubleshooting: Remove all unnecessary components (starting with add-on cards first), and use the minimum configuration (but with a CPU and a memory module installed) to identify the trouble areas. Refer to the steps listed in Section A above for proper troubleshooting procedures.
4. Identifying bad components by isolating them: If necessary, remove a component in question from the chassis, and test it in isolation to make sure that it works properly. Replace a bad component with a good one.
5. Check and change one component at a time instead of changing several items at the same time. This will help isolate and identify the problem.
6. To find out if a component is good, swap this component with a new one to see if the system will work properly. If so, then the old component is bad. You can also install the component in question in another system. If the new system works, the component is good and the old system has problems.

7.4 POST Codes

The AMI UEFI BIOS supplies checkpoint codes, which are documented online at <http://www.supermicro.com/support/manuals/> ("*AMI BIOS POST Codes User's Guide*").

When BIOS performs the Power On Self Test, it writes checkpoint codes to I/O port 0080h. If the computer cannot complete the boot process, the POST codes can be viewed from the BMC using the Post Snooping function.

For information on AMI updates, please refer to <http://www.ami.com/products/>.

7.5 Crash Dump Using IPMI

In the event of a processor internal error (IERR) that crashes your system, you may want to provide information to support staff. You can download a crash dump of status information using IPMI. The IPMI manual is available at <https://www.supermicro.com/solutions/IPMI.cfm>.
Check IPMI Error Log

1. Access the IPMI web interface.
2. Click the **Server Health** tab, then **Event Log** to verify an IERR error.

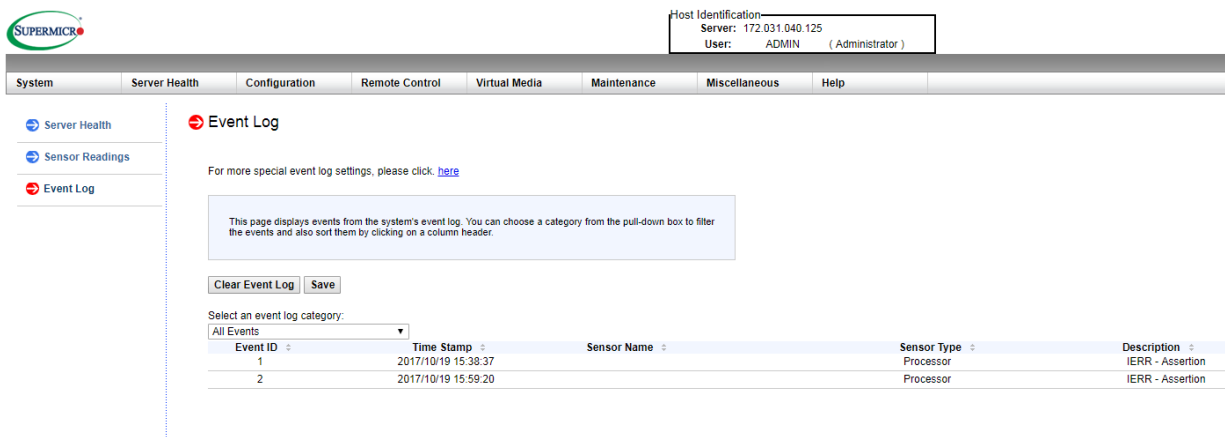

The screenshot shows the IPMI web interface. At the top right, there is a 'Host Identification' box containing 'Server: 172.031.040.125' and 'User: ADMIN (Administrator)'. Below this is a navigation menu with tabs: System, Server Health, Configuration, Remote Control, Virtual Media, Maintenance, Miscellaneous, and Help. The 'Event Log' tab is selected. On the left, there is a sidebar with 'Server Health', 'Sensor Readings', and 'Event Log' (selected). The main content area has a heading 'Event Log' and a sub-heading 'For more special event log settings, please click: [here](#)'. Below this is a text box: 'This page displays events from the system's event log. You can choose a category from the pull-down box to filter the events and also sort them by clicking on a column header.' There are 'Clear Event Log' and 'Save' buttons. A dropdown menu shows 'All Events'. Below is a table with the following data:

Event ID	Time Stamp	Sensor Name	Sensor Type	Description
1	2017/10/19 15:38:37		Processor	IERR - Assertion
2	2017/10/19 15:59:20		Processor	IERR - Assertion

Figure 7-4. IPMI Event Log

In the event of an IERR, the BMC executes a crash dump. You must download the crash dump and save it.

7.6 UEFI BIOS Recovery

Important! Do not upgrade the BIOS unless your system has a BIOS-related issue. Flashing the wrong BIOS can cause irreparable damage to the system. In no event shall Supermicro be liable for direct, indirect, special, incidental, or consequential damages arising from a BIOS update. If you do update the BIOS, do not shut down or reset the system while the BIOS is updating to avoid possible boot failure.

Overview

The Unified Extensible Firmware Interface (UEFI) provides a software-based interface between the operating system and the platform firmware in the pre-boot environment. The UEFI specification supports an architecture-independent mechanism that will allow the UEFI OS loader stored in an add-on card to boot the system. The UEFI offers clean, hands-off management to a computer during system boot.

Recovering the UEFI BIOS Image

A UEFI BIOS flash chip consists of a recovery BIOS block and a main BIOS block (a main BIOS image). The recovery block contains critical BIOS codes, including memory detection and recovery codes for the user to flash a healthy BIOS image if the original main BIOS image is corrupted. When the system power is turned on, the recovery block codes execute first. Once this process is complete, the main BIOS code will continue with system initialization and the remaining POST (Power-On Self-Test) routines.

Note 1: Follow the BIOS recovery instructions below for BIOS recovery when the main BIOS block crashes.

Note 2: When the BIOS recovery block crashes, you will need to follow the procedures to make a Returned Merchandise Authorization (RMA) request. Also, you may use the Supermicro Update Manager (SUM) Out-of-Band (https://www.supermicro.com.tw/products/nfo/SMS_SUM.cfm) to reflash the BIOS.

Recovering the Main BIOS Block with a USB Device

This feature allows the user to recover the main BIOS image using a USB-attached device without additional utilities used. A USB flash device such as a USB Flash Drive, or a USB CD/DVD ROM/RW device can be used for this purpose. However, a USB Hard Disk drive cannot be used for BIOS recovery at this time.

The file system supported by the recovery block is FAT (including FAT12, FAT16, and FAT32) which is installed on a bootable or non-bootable USB-attached device. However, the BIOS might need several minutes to locate the SUPER.ROM file if the media size becomes too large due to the huge volumes of folders and files stored in the device.

To perform UEFI BIOS recovery using a USB-attached device, follow the instructions below.

1. Using a different machine, copy the "Super.ROM" binary image file into the Root "\" directory of a USB device or a writable CD/DVD.

Note 1: If you cannot locate the "Super.ROM" file in your drive disk, visit our website at www.supermicro.com to download the BIOS package. Extract the BIOS binary image into a USB flash device and rename it "Super.ROM" for the BIOS recovery use.

Note 2: Before recovering the main BIOS image, confirm that the "Super.ROM" binary image file you download is the same version or a close version meant for your motherboard.

2. Insert the USB device that contains the new BIOS image ("Super.ROM") into your USB drive and reset the system when the following screen appears.
3. After locating the healthy BIOS binary image, the system will enter the BIOS Recovery menu as shown below.



Note: At this point, you may decide if you want to start the BIOS recovery. If you decide to proceed with BIOS recovery, follow the procedures below.

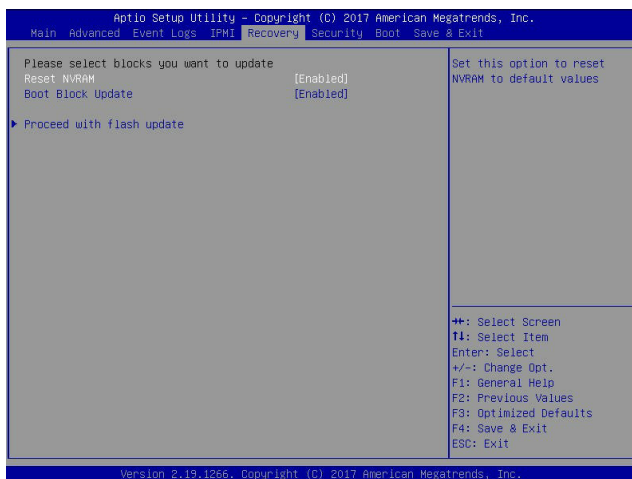

1. When the screen as shown above displays, use the arrow keys to select the item "Proceed with flash update" and press the <Enter> key. You will see the BIOS recovery progress as shown in the screen below.

Note: Do not interrupt the BIOS flashing process until it has been completed.

2. After the BIOS recovery process is complete, press any key to reboot the system.
3. Using a different system, extract the BIOS package into a USB flash drive.

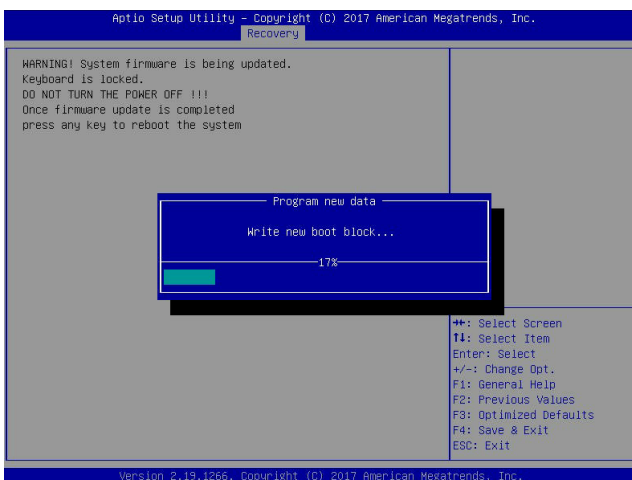

- Press continuously during system boot to enter the BIOS Setup utility. From the top of the toolbar, select Boot to enter the submenu. From the submenu list, select Boot

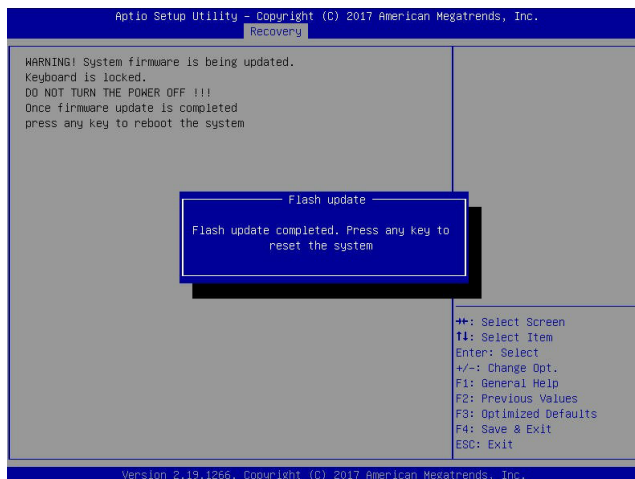

Option #1 as shown below. Then, set Boot Option #1 to [UEFI AP:UEFI: Built-in EFI Shell]. Press <F4> to save the settings and exit the BIOS Setup utility.

- When the UEFI Shell prompt appears, type `fs#` to change the device directory path. Go to the directory that contains the BIOS package you extracted earlier from Step 6. Enter `flash.nsh BIOSname.###` at the prompt to start the BIOS update process.

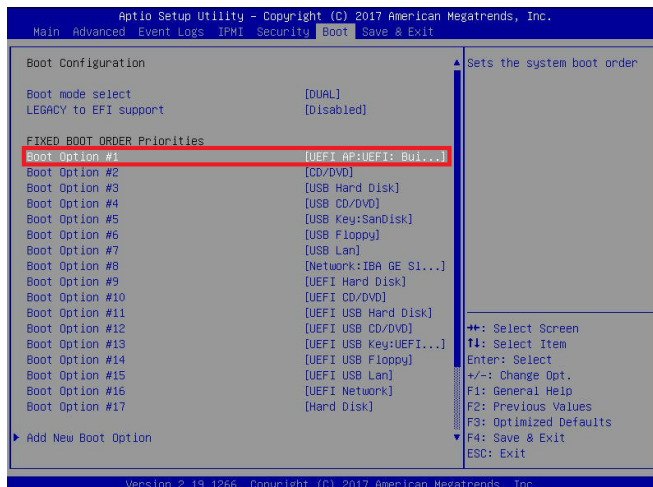

Note: Do not interrupt this process until the BIOS flashing is complete.

```

UEFI Interactive Shell v2.1
EDK II
UEFI v2.50 (American Megatrends, 0x0005000C)
Mapping table
  FS0: Alias(s):HD(0):MB:BLK1:
      PciRoot(0x0)/Pci(0x14,0x0)/USB(0x11,0x0)/HD(1,MBR,0x37901D72,0x800,0x1
CR3932)
  BLK0: Alias(s):
      PciRoot(0x0)/Pci(0x14,0x0)/USB(0x11,0x0)
Press F8 in 1 seconds to skip startup.nsh or any other key to continue.
Shell: fs0:
FS0:\> cd \AFUDOS
FS0:\AFUDOS> cd SNIJPM2_03162017
FS0:\AFUDOS\SNIJPM2_03162017> flash.nsh X110PU7_314

```

1. The screen above indicates that the BIOS update process is complete. When you see the screen above, unplug the AC power cable from the power supply, clear CMOS, and

```

Done.
[ Access Cmos Port Ex ]
<Read>
Index 0x51: 0x10

Done.
*****
* Program BIOS and ME (including FDT) regions...
*****
| AMT Firmware Update Utility v5.09.01.1917 |
| Copyright (C)2017 American Megatrends Inc. All Rights Reserved. |
-----
CPUID = 50652

Reading flash ..... done
- ME Data Size checking - ok
- FFS checksums ..... ok
- Check RomLayout ..... Ok
Erasing Boot Block ..... done
Updating Boot Block ..... done
Verifying Boot Block ..... done
_Erasing Main Block ..... 0x00132000 (0x)

```

plug the AC power cable in the power supply again to power on the system.

2. Press continuously to enter the BIOS Setup utility.

```

Verifying NDB Block ..... done
- Update success for FDR
- Update success for IE
- Successful Update Recovery Loader to OPR!!
- Successful Update MFSB!!
- Successful Update FPR!!
- Successful Update MFS, IVBI and IVB2!!
- Successful Update FLOG and UTDK!!
- ME Entire Image update success !!
WARNING : System must power-off to have the changes take effect!
Moving FS0:\AFUDOS\SNIJPM2_03162017\fdt\k64.efi -> FS0:\AFUDOS\SNIJPM2_03162017\
d1.smc
- [ok]
Moving FS0:\AFUDOS\SNIJPM2_03162017\afuef1k64.efi -> FS0:\AFUDOS\SNIJPM2_0316201
7\afuef1.smc
- [ok]
*****
* Please ignore this 'Shell: Cannot read from file - Device Error'
* warning message due to it does not impact flashing process.
*****
Deleting "afuef1.smc"
Delete successful.
FS0:\>

```

3. Press <F3> to load the default settings.
4. After loading the default settings, press <F4> to save the settings and exit the BIOS Setup utility.

7.7 CMOS Clear

JBT1 is used to clear CMOS, which will also clear any passwords. Instead of pins, this jumper consists of contact pads to prevent accidentally clearing the contents of CMOS.

To Clear CMOS

1. First [power down](#) the system completely.
2. [Remove the cover](#) of the chassis to access the motherboard.
3. [Remove the onboard battery](#) from the motherboard.
4. Short the CMOS pads with a metal object such as a small screwdriver for at least four seconds.
5. Remove the screwdriver or shorting device.
6. Replace the cover, reconnect the power cords, and power on the system.

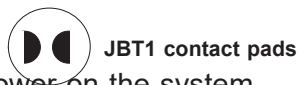

Notes: Clearing CMOS will also clear all passwords.

Do not use the PW_ON connector to clear CMOS.

7.8 Where to Get Replacement Components

If you need replacement parts for your system, to ensure the highest level of professional service and technical support, purchase exclusively from our Supermicro Authorized Distributors/System Integrators/Resellers. A list can be found at: <http://www.supermicro.com>. Click the "Where to Buy" tab.

7.9 Reporting an Issue

Technical Support Procedures

Before contacting Technical Support, please take the following steps. If your system was purchased through a distributor or reseller, please contact them for troubleshooting services. They have the best knowledge of your specific system configuration.

1. Please review the [Troubleshooting Procedures](#) in this manual and [Frequently Asked Questions](#) on our website before contacting Technical Support.
2. BIOS upgrades can be downloaded from our website. **Note:** Not all BIOS can be flashed depending on the modifications to the boot block code.
3. If you still cannot resolve the problem, include the following information when contacting us for technical support:
 - System, motherboard, and chassis model numbers and PCB revision number
 - BIOS release date/version (this can be seen on the initial display when your system first boots up)
 - System configuration

An example of a Technical Support form is posted on our [website](#). Distributors: For immediate assistance, please have your account number ready when contacting our technical support department by email.

Returning Merchandise for Service

A receipt or copy of your invoice marked with the date of purchase is required before any warranty service will be rendered. You can obtain service by calling your vendor for a Returned Merchandise Authorization (RMA) number. When returning to the manufacturer, the RMA number should be prominently displayed on the outside of the shipping carton, and mailed prepaid or hand-carried. Shipping and handling charges will be applied for all orders that must be mailed when service is complete.

For faster service, RMA authorizations may be requested online (<http://www.supermicro.com/support/rma/>).

Whenever possible, repack the chassis in the original Supermicro carton, using the original packaging material. If these are no longer available, be sure to pack the chassis securely, using packaging material to surround the chassis so that it does not shift within the carton and become damaged during shipping.

This warranty only covers normal consumer use and does not cover damages incurred in shipping, or from failure due to the alteration, misuse, abuse or improper maintenance of products.

During the warranty period, contact your distributor first for any product problems.

Vendor Support Filing System

For issues related to Intel, use the Intel IPS filing system:

<https://www.intel.com/content/www/us/en/design/support/ips/training/welcome.html>

For issues related to Red Hat Enterprise Linux, since it is a subscription based OS, contact your account representative.

7.10 Feedback

Supermicro values your feedback as we strive to improve our customer experience in all facets of our business. Please email us at techwriterteam@supermicro.com to provide feedback on our manuals.

7.11 Contacting Supermicro

Headquarters

Address: Super Micro Computer, Inc.
980 Rock Ave.
San Jose, CA 95131 U.S.A.

Tel: +1 (408) 503-8000

Fax: +1 (408) 503-8008

Email: marketing@supermicro.com (General Information)
Sales-USA@supermicro.com (Sales Inquiries)
Government_Sales-USA@supermicro.com (Gov. Sales Inquiries)
support@supermicro.com (Technical Support)
RMA@supermicro.com (RMA Support)
Webmaster@supermicro.com (Webmaster)

Website: www.supermicro.com

Europe

Address: Super Micro Computer B.V.
Het Sterrenbeeld 28, 5215 ML
's-Hertogenbosch, The Netherlands

Tel: +31 (0) 73-6400390

Fax: +31 (0) 73-6416525

Email: Sales_Europe@supermicro.com (Sales Inquiries)
Support_Europe@supermicro.com (Technical Support)
RMA_Europe@supermicro.com (RMA Support)

Website: www.supermicro.nl

Asia-Pacific

Address: Super Micro Computer, Inc.
3F, No. 150, Jian 1st Rd.
Zhonghe Dist., New Taipei City 235
Taiwan (R.O.C)

Tel: +886-(2) 8226-3990

Fax: +886-(2) 8226-3992

Email: Sales-Asia@supermicro.com.tw (Sales Inquiries)
Support@supermicro.com.tw (Technical Support)
RMA@supermicro.com.tw (RMA Support)

Website: www.supermicro.com.tw

Appendix A

Standardized Warning Statements for AC Systems

About Standardized Warning Statements

The following statements are industry standard warnings, provided to warn the user of situations which have the potential for bodily injury. Should you have questions or experience difficulty, contact Supermicro's Technical Support department for assistance. Only certified technicians should attempt to install or configure components.

Read this appendix in its entirety before installing or configuring components in the Supermicro chassis.

These warnings may also be found on our website at http://www.supermicro.com/about/policies/safety_information.cfm.

Warning Definition



Warning! This warning symbol means danger. You are in a situation that could cause bodily injury. Before you work on any equipment, be aware of the hazards involved with electrical circuitry and be familiar with standard practices for preventing accidents.

警告の定義

この警告サインは危険を意味します。

人身事故につながる可能性がありますので、いずれの機器でも動作させる前に、電気回路に含まれる危険性に注意して、標準的な事故防止策に精通して下さい。

此警告符号代表危險。

您正处于可能受到严重伤害的工作环境中。在您使用设备开始工作之前，必须充分意识到触电的危险，并熟练掌握防止事故发生的标准工作程序。请根据每项警告结尾的声明号码找到此设备的安全性警告说明的翻译文本。

此警告符號代表危險。

您正處於可能身體可能會受損傷的工作環境中。在您使用任何設備之前，請注意觸電的危險，並且要熟悉預防事故發生的標準工作程序。請依照每一注意事項後的號碼找到相關的翻譯說明內容。

Warnung

WICHTIGE SICHERHEITSHINWEISE

Dieses Warnsymbol bedeutet Gefahr. Sie befinden sich in einer Situation, die zu Verletzungen führen kann. Machen Sie sich vor der Arbeit mit Geräten mit den Gefahren elektrischer Schaltungen und den üblichen Verfahren zur Vorbeugung vor Unfällen vertraut. Suchen Sie mit der am Ende jeder Warnung angegebenen Anweisungsnummer nach der jeweiligen Übersetzung in den übersetzten Sicherheitshinweisen, die zusammen mit diesem Gerät ausgeliefert wurden.

BEWAHREN SIE DIESE HINWEISE GUT AUF.

INSTRUCCIONES IMPORTANTES DE SEGURIDAD

Este símbolo de aviso indica peligro. Existe riesgo para su integridad física. Antes de manipular cualquier equipo, considere los riesgos de la corriente eléctrica y familiarícese con los procedimientos estándar de prevención de accidentes. Al final de cada advertencia encontrará el número que le ayudará a encontrar el texto traducido en el apartado de traducciones que acompaña a este dispositivo.

GUARDE ESTAS INSTRUCCIONES.

IMPORTANTES INFORMATIONS DE SÉCURITÉ

Ce symbole d'avertissement indique un danger. Vous vous trouvez dans une situation pouvant entraîner des blessures ou des dommages corporels. Avant de travailler sur un équipement, soyez conscient des dangers liés aux circuits électriques et familiarisez-vous avec les procédures couramment utilisées pour éviter les accidents. Pour prendre connaissance des traductions des avertissements figurant dans les consignes de sécurité traduites qui accompagnent cet appareil, référez-vous au numéro de l'instruction situé à la fin de chaque avertissement.

CONSERVEZ CES INFORMATIONS.

תקנון הזהרות אזהרה

הזהרות הבאות הן אזהרות על פי תקני התעשייה, על מנת להזהיר את המשתמש מפני חבלה פיזית אפשרית. במידה ויש שאלות או היתקלות בבעיה כלשהי, יש ליצור קשר עם מחלקת תמיכה טכנית של סופרמיקרו. טכנאים מוסמכים בלבד רשאים להתקין או להגדיר את הרכיבים. יש לקרוא את הנספח במלואו לפני התקנת או הגדרת הרכיבים במארזי סופרמיקרו.

اَكْ ف حالة وُكِي اَي تتسبب ف اصابة جسدهُ هذا الزهز عُ خطر! تحذُرُ .
 قبل اَي تعول على اَي هعدات، كي على علن بالوخاطز ال اُجوة عي الذوائر
 الكهزبائِة
 وكي على دراةُ بالووارسات النقااِة لو عُ وقع اَي حادث
 استخدم رقن الب اِى الو صُص ف هاةُ كل تحذُرُ للعشر تزجوتها

안전을 위한 주의사항

경고!

이 경고 기호는 위험이 있음을 알려 줍니다. 작업자의 신체에 부상을 야기 할 수 있는 상태에 있게 됩니다. 모든 장비에 대한 작업을 수행하기 전에 전기회로와 관련된 위험요소들을 확인하시고 사전에 사고를 방지할 수 있도록 표준 작업절차를 준수해 주시기 바랍니다.

해당 번역문을 찾기 위해 각 경고의 마지막 부분에 제공된 경고문 번호를 참조하십시오

BELANGRIJKE VEILIGHEIDSINSTRUCTIES

Dit waarschuwings symbool betekent gevaar. U verkeert in een situatie die lichamelijk letsel kan veroorzaken. Voordat u aan enige apparatuur gaat werken, dient u zich bewust te zijn van de bij een elektrische installatie betrokken risico's en dient u op de hoogte te zijn van de standaard procedures om ongelukken te voorkomen. Gebruik de nummers aan het eind van elke waarschuwing om deze te herleiden naar de desbetreffende locatie.

BEWAAR DEZE INSTRUCTIES

Installation Instructions



Warning! Read the installation instructions before connecting the system to the power source.

設置手順書

システムを電源に接続する前に、設置手順書をお読み下さい。

警告

将此系统连接电源前,请先阅读安装说明。

警告

將系統與電源連接前，請先閱讀安裝說明。

Warnung

Vor dem Anschließen des Systems an die Stromquelle die Installationsanweisungen lesen.

¡Advertencia!

Lea las instrucciones de instalación antes de conectar el sistema a la red de alimentación.

Attention

Avant de brancher le système sur la source d'alimentation, consulter les directives d'installation.

יש לקרוא את הוראות התקנה לפני חיבור המערכת למקור מתח.

اقرأ إرشادات التركيب قبل توصيل النظام إلى مصدر للطاقة

시스템을 전원에 연결하기 전에 설치 안내를 읽어주십시오.

Waarschuwing

Raadpleeg de installatie-instructies voordat u het systeem op de voedingsbron aansluit.

Circuit Breaker

Warning! This product relies on the building's installation for short-circuit (overcurrent) protection. Ensure that the protective device is rated not greater than: 250 V, 20 A.

サーキット・ブレーカー

この製品は、短絡(過電流)保護装置がある建物での設置を前提としています。

保護装置の定格が250 V、20 Aを超えないことを確認下さい。

警告

此产品的短路(过载电流)保护由建筑物的供电系统提供,确保短路保护设备的额定电流不大于250V,20A。

警告

此產品的短路(過載電流)保護由建築物的供電系統提供,確保短路保護設備的額定電流不大於250V,20A。

Warnung

Dieses Produkt ist darauf angewiesen, dass im Gebäude ein Kurzschluss- bzw. Überstromschutz installiert ist. Stellen Sie sicher, dass der Nennwert der Schutzvorrichtung nicht mehr als: 250 V, 20 A beträgt.

¡Advertencia!

Este equipo utiliza el sistema de protección contra cortocircuitos (o sobrecorrientes) del edificio. Asegúrese de que el dispositivo de protección no sea superior a: 250 V, 20 A.

Attention

Pour ce qui est de la protection contre les courts-circuits (surtension), ce produit dépend de l'installation électrique du local. Vérifiez que le courant nominal du dispositif de protection n'est pas supérieur à :250 V, 20 A.

מוצר זה מסתמך על הגנה המותקנת במבנים למניעת קצר חשמלי. יש לוודא כי המכשיר המגן מפני הקצר החשמלי הוא לא יותר מ-250V, 20A.

هذا المنتج يعتمد على معدات الحماية من الدوائر القصيرة التي تم تثبيتها في المبنى
تأكد من أن تقييم الجهاز الوقائي ليس أكثر من : 20A, 250V

경고!

이 제품은 전원의 단락(과전류)방지에 대해서 전적으로 건물의 관련 설비에 의존합니다. 보호장치의 정격이 반드시 250V(볼트), 20A(암페어)를 초과하지 않도록 해야 합니다.

Waarschuwing

Dit product is afhankelijk van de kortsluitbeveiliging (overspanning) van uw elektrische installatie. Controleer of het beveiligde apparaat niet groter gedimensioneerd is dan 250V, 20A.

Power Disconnection Warning



Warning! The system must be disconnected from all sources of power and the power cord removed from the power supply module(s) before accessing the chassis interior to install or remove system components (except for hot-swap components).



電源切断の警告

システムコンポーネントの取り付けまたは取り外しのために、シャーシ内部にアクセスするには、システムの電源はすべてのソースから切断され、電源コードは電源モジュールから取り外す必要があります。

警告

在你打开机箱并安装或移除内部器件前,必须将系统完全断电,并移除电源线。

警告

在您打開機殼安裝或移除內部元件前，必須將系統完全斷電，並移除電源線。

Warnung

Das System muss von allen Quellen der Energie und vom Netzanschlusskabel getrennt sein, das von den Spg.Versorgungsteilmodulen entfernt wird, bevor es auf den Chassisinnenraum zurückgreift, um Systemsbestandteile anzubringen oder zu entfernen.

¡Advertencia!

El sistema debe ser disconnected de todas las fuentes de energía y del cable eléctrico quitado de los módulos de fuente de alimentación antes de tener acceso el interior del chasis para instalar o para quitar componentes de sistema.

Attention

Le système doit être débranché de toutes les sources de puissance ainsi que de son cordon d'alimentation secteur avant d'accéder à l'intérieur du chassis pour installer ou enlever des composants de système.

אזהרה מפני ניתוק חשמלי

אזהרה!

יש לנתק את המערכת מכל מקורות החשמל ויש להסיר את כבל החשמלי מהספק לפני גישה לחלק הפנימי של המארז לצורך התקנת או הסרת רכיבים.

يجب فصل انظاؤ من جميع مصادر انطاقت وإزانت سهك انكهرباء من وحدة امداد انطاقت قيم

انصل إلى امناطق انداخييت نههيكم نشييج أو إزانت مكناث الجهاز

경고!

시스템에 부품들을 장착하거나 제거하기 위해서는 새시 내부에 접근하기 전에 반드시 전원 공급장치로부터 연결되어있는 모든 전원과 전기코드를 분리해주어야 합니다.

Waarschuwing

Voordat u toegang neemt tot het binnenwerk van de behuizing voor het installeren of verwijderen van systeem onderdelen, dient u alle spanningsbronnen en alle stroomkabels aangesloten op de voeding(en) van de behuizing te verwijderen

Equipment Installation



Warning! Only authorized personnel and qualified service persons should be allowed to install, replace, or service this equipment.

機器の設置

トレーニングを受け認定された人だけがこの装置の設置、交換、またはサービスを許可されています。

警告

只有经过培训且具有资格的人员才能进行此设备的安装、更换和维修。

警告

只有經過受訓且具資格人員才可安裝、更換與維修此設備。

Warnung

Nur autorisiertes Personal und qualifizierte Servicetechniker dürfen dieses Gerät installieren, austauschen oder warten..

¡Advertencia!

Sólo el personal autorizado y el personal de servicio calificado deben poder instalar, reemplazar o dar servicio a este equipo.

Attention

Seul le personnel autorisé et le personnel de maintenance qualifié doivent être autorisés à installer, remplacer ou entretenir cet équipement..

אזהרה!

יש לאפשר רק צוות מורשה ואנשי שירות מוסמכים להתקין, להחליף או לטפל בציוד זה.

ينبغي السماح فقط للموظفين المعتمدين وأفراد الخدمة المؤهلين بتركيب هذا الجهاز أو استبداله أو صيانته.

경고!

승인된 직원과 자격을 갖춘 서비스 담당자만이 이 장비를 설치, 교체 또는 서비스할 수 있습니다.

Waarschuwing

Alleen geautoriseerd personeel en gekwalificeerd onderhoudspersoneel mag deze apparatuur installeren, vervangen of onderhouden..

Rack Stability Hazard

Warning! Stability hazard. The rack may tip over causing serious personal injury. Before extending the rack to the installation position, read the installation instructions.

ファンの警告

安定性に危険があります。ラックが転倒して、重大な人身事故を引き起こす可能性があります。ラックを設置位置まで伸ばす前に、設置手順をお読みください。設置位置にあるスライド レールに取り付けられた機器に負荷をかけないでください。スライド レールに取り付けられた機器を設置位置に放置しないでください。

警告

稳定性危険。机架可能会翻倒，造成严重的人身伤害。在将机架延伸到安装位置之前，请阅读安装说明。请勿在安装位置对滑轨安装的设备施加任何负载。请勿将滑轨安装的设备留在安装位置。

警告

穩定性危險。機架可能會翻倒，造成嚴重的人身傷害。將機架延伸至安裝位置前，請先閱讀安裝說明。請勿在安裝位置的滑軌安裝設備上放置任何負載。請勿將滑軌安裝設備留在安裝位置。

Warnung

Gefahr der Instabilität. Das Rack kann umkippen und schwere Verletzungen verursachen. Lesen Sie die Installationsanweisungen, bevor Sie das Rack in die Einbauposition ausfahren. Belasten Sie die auf den Gleitschienen montierten Geräte nicht in der Einbauposition. Lassen Sie die auf den Gleitschienen montierten Geräte nicht in der Einbauposition.

¡Advertencia!

Peligro de inestabilidad. El rack podría volcarse y causar lesiones personales graves. Antes de extender el rack a la posición de instalación, lea las instrucciones de instalación. No coloque ninguna carga sobre el equipo montado sobre rieles deslizantes en la posición de instalación. No deje el equipo montado sobre rieles deslizantes en la posición de instalación. Sólo el personal autorizado y el personal de servicio calificado deben poder instalar, reemplazar o dar servicio a este equipo.

Avertissement!

Danger d'instabilité. Le rack peut basculer et provoquer des blessures corporelles graves. Avant d'étendre le rack en position d'installation, lire les instructions d'installation. Ne pas charger l'équipement monté sur rail de glissière en position d'installation. Ne pas laisser l'équipement monté sur rail de glissière en position d'installation.

אזהרה!

סכנת חוסר יציבות

המתלה עלול להתהפך ולגרום לפציעה חמורה

לפני הארכת המתלה למצב ההתקנה, קרא את הוראות ההתקנה

אין להעמיס כל עומס על הציוד המותקן על מסילת ההחלקה במצב ההתקנה

אל תשאיר את הציוד המותקן על מסילת ההחלקה במצב ההתקנה

تحذير. خطر عدم الاستقرار. قد ينقلب الرف مسبباً إصابات جسدية خطيرة. قبل تمديد الرف إلى موضع التركيب، اقرأ تعليمات التركيب. لا تضع أي حمولة على الجهاز المثبت على سكة الانزلاق في موضع التركيب. لا تترك الجهاز المثبت على سكة الانزلاق في موضع التركيب.

경고!

안정성 위험. 랙이 넘어져 심각한 개인 부상을 입을 수 있습니다. 랙을 설치 위치까지 확장하기 전에 설치 지침을 읽으십시오. 설치 위치에서 슬라이드 레일 장착 장비에 하중을 가하지 마십시오. 슬라이드 레일 장착 장비를 설치 위치에 두지 마십시오.

Waarschuwing

Gevaar voor instabiliteit. Het rek kan kantelen en ernstig persoonlijk letsel veroorzaken. Lees de installatie-instructies voordat u het rek uitschuift naar de installatiepositie. Plaats geen last op de op de glijrail gemonteerde apparatuur in de installatiepositie. Laat de op de glijrail gemonteerde apparatuur niet in de installatiepositie staan.

Restricted Area



Warning! This unit is intended for installation in restricted access areas. A restricted access area can be accessed only through the use of a special tool, lock and key, or other means of security. (This warning does not apply to workstations).

アクセス制限区域

このユニットは、アクセス制限区域に設置されることを想定しています。

アクセス制限区域は、特別なツール、鍵と錠前、その他のセキュリティの手段を用いてのみ出入りが可能です。

警告

此部件应安装在限制进出的场所。限制进出的场所指只能通过使用特殊工具、锁和钥匙或其它安全手段进出的场所。

警告

此装置仅限安装於進出管制區域。進出管制區域係指僅能以特殊工具、鎖頭及鑰匙或其他安全方式才能進入的區域。

Warnung

Diese Einheit ist zur Installation in Bereichen mit beschränktem Zutritt vorgesehen. Der Zutritt zu derartigen Bereichen ist nur mit einem Spezialwerkzeug, Schloss und Schlüssel oder einer sonstigen Sicherheitsvorkehrung möglich.

¡Advertencia!

Esta unidad ha sido diseñada para instalación en áreas de acceso restringido. Sólo puede obtenerse acceso a una de estas áreas mediante la utilización de una herramienta especial, cerradura con llave u otro medio de seguridad.

Attention

Cet appareil doit être installée dans des zones d'accès réservés. L'accès à une zone d'accès réservé n'est possible qu'en utilisant un outil spécial, un mécanisme de verrouillage et une clé, ou tout autre moyen de sécurité.

אזור עם גישה מוגבלת

אזהרה!

יש להתקין את היחידה באזורים שיש בהם הגבלת גישה. הגישה ניתנת בעזרת 'כלי אבטחה בלבד' (מפתח, מנעול וכד.).

تخصيص هذه انحدة نترك بُها ف مناطق محظورة تم .
ممكن انصلل إن منطقت محظورة فقط من خلال استخذاو أداة خاصت
أو أ وس هُت أخري نلالأمما ققم ومفتاح

경고!

이 장치는 접근이 제한된 구역에 설치하도록 되어있습니다. 특수도구, 잠금 장치 및 키, 또는 기타 보안 수단을 통해서만 접근 제한 구역에 들어갈 수 있습니다.

Waarschuwing

Dit apparaat is bedoeld voor installatie in gebieden met een beperkte toegang. Toegang tot dergelijke gebieden kunnen alleen verkregen worden door gebruik te maken van speciaal gereedschap, slot en sleutel of andere veiligheidsmaatregelen.

Battery Handling



CAUTION: There is risk of explosion if the battery is replaced by an incorrect type. Replace the battery only with the same or equivalent type recommended by the manufacturer. Dispose of used batteries according to the manufacturer's instructions

電池の取り扱い

バッテリーを間違ったタイプに交換すると爆発の危険があります。交換する電池はメーカーが推奨する型、または同等のものを使用下さい。使用済電池は製造元の指示に従って処分して下さい。

警告

如果更换的电池类型不正确，则存在爆炸危险。请只使用同类电池或制造商推荐的功能相当的电池更换原有电池。请按制造商的说明处理废旧电池。

警告

如果更換的電池類型不正確，則有爆炸危險。請使用製造商建議之相同或功能相當的電池更換原有電池。請按照製造商的說明指示處理廢棄舊電池。

WARNUNG

Es besteht Explosionsgefahr, wenn die Batterie durch einen falschen Typ ersetzt wird. Ersetzen Sie die Batterie nur durch den gleichen oder vom Hersteller empfohlenen Batterietyp. Entsorgen Sie die benutzten Batterien nach den Anweisungen des Herstellers.

ATTENTION

Il existe un risque d'explosion si la batterie est remplacée par un type incorrect. Ne la remplacer que par une pile de type semblable ou équivalent, recommandée par le fabricant. Jeter les piles usagées conformément aux instructions du fabricant.

ADVERTENCIA

Existe riesgo de explosión si la batería se reemplaza por un tipo incorrecto. Reemplazar la batería exclusivamente con el mismo tipo o el equivalente recomendado por el fabricante. Desechar las baterías gastadas según las instrucciones del fabricante.

אזהרה!

קיימת סכנת פיצוץ אם הסוללה תוחלף בסוג שגוי. יש להחליף את הסוללה בסוג התואם מחברת יצרן מומלצת. סילוק הסוללות המשומשות יש לבצע לפי הוראות היצרן.

هناك خطر الانفجار إذا تم استبدال البطارية بنوع غير صحيح.
 اسحبذال البطارية
 فقط بنفس النوع أو ما يعادلها مما أوصت به الشركة المصنعة
 جخلص من البطاريات المسحمة وفقا لعمليات الشركة الصانعة

경고!

배터리를 잘못된 종류로 교체하면 폭발의 위험이 있습니다. 기존 배터리와 동일하거나 제조사에서 권장하는 동등한 종류의 배터리로만 교체해야 합니다. 제조사의 안내에 따라 사용된 배터리를 처리하여 주십시오.

WAARSCHUWING

Er bestaat explosiegevaar als de batterij wordt vervangen door een verkeerd type. Vervang de batterij slechts met hetzelfde of een equivalent type die door de fabrikant aanbevolen wordt. Gebruikte batterijen dienen overeenkomstig fabrieksvoorschriften afgevoerd te worden.

Redundant Power Supplies



Warning! This unit might have more than one power supply connection. All connections must be removed to de-energize the unit.

冗長電源装置

このユニットは複数の電源装置が接続されている場合があります。

ユニットの電源を切るためには、すべての接続を取り外さなければなりません。

警告

此部件连接的电源可能不止一个，必须将所有电源断开才能停止给该部件供电。

警告

此装置连接的电源可能不只一个，必须切断所有电源才能停止对该装置的供电。

Warnung

Dieses Gerät kann mehr als eine Stromzufuhr haben. Um sicherzustellen, dass der Einheit kein Strom zugeführt wird, müssen alle Verbindungen entfernt werden.

¡Advertencia!

Puede que esta unidad tenga más de una conexión para fuentes de alimentación. Para cortar por completo el suministro de energía, deben desconectarse todas las conexiones.

Attention

Cette unité peut avoir plus d'une connexion d'alimentation. Pour supprimer toute tension et tout courant électrique de l'unité, toutes les connexions d'alimentation doivent être débranchées.

אם קיים יותר מספק אחד

אזהרה!

ליחידה יש יותר מחיבור אחד של ספק. יש להסיר את כל החיבורים על מנת לרוקן את היחידה.

قد يكون لهذا الجهاز عدة اتصالات بوحدات امداد الطاقة .

يجب إزالة كافة الاتصالات لعسل الوحدة عن الكهرباء

경고!

이 장치에는 한 개 이상의 전원 공급 단자가 연결되어 있을 수 있습니다. 이 장치에 전원을 차단하기 위해서는 모든 연결 단자를 제거해야만 합니다.

Waarschuwing

Deze eenheid kan meer dan één stroomtoevoeraansluiting bevatten. Alle aansluitingen dienen verwijderd te worden om het apparaat stroomloos te maken.

Backplane Voltage



Warning! Hazardous voltage or energy is present on the backplane when the system is operating. Use caution when servicing.

バックプレーンの電圧

システムの稼働中は危険な電圧または電力が、バックプレーン上にかかっています。

修理する際には注意ください。

警告

当系统正在进行时，背板上有很危险的电压或能量，进行维修时务必小心。

警告

當系統正在進行時，背板上有危險的電壓或能量，進行維修時務必小心。

Warnung

Wenn das System in Betrieb ist, treten auf der Rückwandplatine gefährliche Spannungen oder Energien auf. Vorsicht bei der Wartung.

¡Advertencia!

Cuando el sistema está en funcionamiento, el voltaje del plano trasero es peligroso. Tenga cuidado cuando lo revise.

Attention

Lorsque le système est en fonctionnement, des tensions électriques circulent sur le fond de panier. Prendre des précautions lors de la maintenance.

מתח בפנל האחורי

אזהרה!

קיימת סכנת מתח בפנל האחורי בזמן תפעול המערכת. יש להיזהר במהלך העבודה.

هناك خطر من التيار الكهربائي أو الطاقة المتجددة على اللوحة
عندما يكون النظام يعمل كه حذرا عند خدمة هذا الجهاز

경고!

시스템이 동작 중일 때 후면판 (Backplane)에는 위험한 전압이나 에너지가 발생 합니다.
서비스 작업 시 주의하십시오.

Waarschuwing

Een gevaarlijke spanning of energie is aanwezig op de backplane wanneer het systeem in gebruik is. Voorzichtigheid is geboden tijdens het onderhoud.

Comply with Local and National Electrical Codes



Warning! Installation of the equipment must comply with local and national electrical codes.

地方および国の電気規格に準拠

機器の取り付けはその地方および国の電気規格に準拠する必要があります。

警告

设备安装必须符合本地与本国电气法规。

警告

設備安裝必須符合本地與本國電氣法規。

Warnung

Die Installation der Geräte muss den Sicherheitsstandards entsprechen.

¡Advertencia!

La instalación del equipo debe cumplir con las normas de electricidad locales y nacionales.

Attention

L'équipement doit être installé conformément aux normes électriques nationales et locales.

תיאום חוקי החשמל הארצי
אזהרה!
התקנת הציוד חייבת להיות תואמת לחוקי החשמל המקומיים והארציים.

تركيب المعدات الكهربائية يجب أن يمتثل للقوايه المحلية والبطية المتعلقة
بالكهرباء

경고!

현 지역 및 국가의 전기 규정에 따라 장비를 설치해야 합니다.

Waarschuwing

Bij installatie van de apparatuur moet worden voldaan aan de lokale en nationale elektriciteitsvoorschriften.

Product Disposal



Warning! Ultimate disposal of this product should be handled according to all national laws and regulations.

製品の廃棄

この製品を廃棄処分する場合、国の関係する全ての法律・条例に従い処理する必要があります。

警告

本产品的废弃处理应根据所有国家的法律和规章进行。

警告

本產品的廢棄處理應根據所有國家的法律和規章進行。

Warnung

Die Entsorgung dieses Produkts sollte gemäß allen Bestimmungen und Gesetzen des Landes erfolgen.

¡Advertencia!

Al deshacerse por completo de este producto debe seguir todas las leyes y reglamentos nacionales.

Attention

La mise au rebut ou le recyclage de ce produit sont généralement soumis à des lois et/ou directives de respect de l'environnement. Renseignez-vous auprès de l'organisme compétent.

סילוק המוצר

אזהרה!

סילוק סופי של מוצר זה חייב להיות בהתאם להנחיות וחוקי המדינה.

التخلص النهائي من هذا المنتج ينبغي التعامل معه وفقا لجميع القوانين واللوائح الوطنية عند

경고!

이 제품은 해당 국가의 관련 법규 및 규정에 따라 폐기되어야 합니다.

Waarschuwing

De uiteindelijke verwijdering van dit product dient te geschieden in overeenstemming met alle nationale wetten en reglementen.

Fan Warning



Warning! Hazardous moving parts. Keep away from moving fan blades. The fans might still be turning when you remove the fan assembly from the chassis. Keep fingers, screwdrivers, and other objects away from the openings in the fan assembly's housing.

ファンの警告

警告!回転部品に注意。運転中は回転部(羽根)に触れないでください。シャーシから冷却ファン装置を取り外した際、ファンがまだ回転している可能性があります。ファンの開口部に、指、ドライバー、およびその他のものを近づけないで下さい。

警告!

警告! 危險的可移動性零件。請務必與轉動的风扇叶片保持距離。當您從機架移除風扇裝置，風扇可能仍在轉動。小心不要將手指、螺絲起子和其他物品太靠近風扇

警告

危險的可移動性零件。請務必與轉動的风扇叶片保持距離。當您從機架移除風扇裝置，風扇可能仍在轉動。小心不要將手指、螺絲起子和其他物品太靠近風扇。

Warnung

Gefährlich Bewegende Teile. Von den bewegenden Lüfterblätter fern halten. Die Lüfter drehen sich u. U. noch, wenn die Lüfterbaugruppe aus dem Chassis genommen wird. Halten Sie Finger, Schraubendreher und andere Gegenstände von den Öffnungen des Lüftergehäuses entfernt.

¡Advertencia!

Riesgo de piezas móviles. Mantener alejado de las aspas del ventilador. Los ventiladores podran dar vuelta cuando usted quite el montaje del ventilador del chasis. Mantenga los dedos, los destornilladores y todos los objetos lejos de las aberturas del ventilador

Attention

Pieces mobiles dangereuses. Se tenir a l'écart des lames du ventilateur Il est possible que les ventilateurs soient toujours en rotation lorsque vous retirerez le bloc ventilateur du châssis. Prenez garde à ce que doigts, tournevis et autres objets soient éloignés du logement du bloc ventilateur.

אזהרה!

חלקים נעים מסוכנים. התרחק מלהבי המאוורר בפעולה כאשר מסירים את חלקי המאוורר מהמארז, יתכן והמאווררים עדיין עובדים. יש להרחיק למרחק בטוח את האצבעות וכלי עבודה שונים מהפתחים בתוך המאוורר

تحذير! أجزاء متحركة خطيرة. ابتعد عن شفرات المروحة المتحركة. من الممكن أن المراوح لا تزال تدور عند إزالة كتلة المروحة من الهيكل يجب إبقاء الأصابع ومفكات البراغي وغيرها من الأشياء بعيدا عن الفتحات في كتلة المروحة.

경고!

움직이는 위험한 부품. 회전하는 송풍 날개에 접근하지 마세요. 새시로부터 팬 조립품을 제거할 때 팬은 여전히 회전하고 있을 수 있습니다. 팬 조립품 외관의 열려있는 부분들로부터 손가락 및 스크류드라이버, 다른 물체들이 가까이 하지 않도록 배치해 주십시오.

Waarschuwing

Gevaarlijk bewegende onderdelen. Houd voldoende afstand tot de bewegende ventilatorbladen. Het is mogelijk dat de ventilator nog draait tijdens het verwijderen van het ventilatorsamenstel uit het chassis. Houd uw vingers, schroevendraaiers en eventuele andere voorwerpen uit de buurt van de openingen in de ventilatorbehuizing.

Power Cable and AC Adapter



Warning! When installing the product, use the provided or designated connection cables, power cables and AC adaptors. Using any other cables and adaptors could cause a malfunction or a fire. Electrical Appliance and Material Safety Law prohibits the use of UL or CSA -certified cables (that have UL/CSA shown on the cord) for any other electrical devices than products designated by Supermicro only.

電源コードとACアダプター

製品を設置する場合、提供または指定および購入された接続ケーブル、電源コードとACアダプターを該当する地域の条例や安全基準に適合するコードサイズやプラグと共に使用下さい。他のケーブルやアダプタを使用すると故障や火災の原因になることがあります。

電気用品安全法は、ULまたはCSA認定のケーブル(UL/CSAマークがコードに表記)を Supermicro が指定する製品以外に使用することを禁止しています。

警告

安装此产品时,请使用本身提供的或指定的或采购的连接线,电源线和电源适配器。包含遵照当地法规和安全要求的合规的电源线尺寸和插头。使用其它线材或适配器可能会引起故障或火灾。除了Supermicro所指定的产品,电气用品和材料安全法律规定禁止使用未经UL或CSA认证的线材。(线材上会显示UL/CSA符号)。

警告

安裝此產品時,請使用本身提供的或指定的或採購的連接線,電源線和電源適配器。包含遵照當地法規和安全要求的合規的電源線尺寸和插頭。使用其它線材或適配器可能會引起故障或火災。除了Supermicro所指定的產品,電氣用品和材料安全法律規定禁止使用未經UL或CSA認證的線材。(線材上會顯示UL/CSA符號)。

Warnung

Nutzen Sie beim Installieren des Produkts ausschließlich die von uns zur Verfügung gestellten Verbindungskabeln, Stromkabeln und/oder Adapter, die Ihre örtlichen Sicherheitsstandards einhalten. Der Gebrauch von anderen Kabeln und Adapter können Fehlfunktionen oder Feuer verursachen. Die Richtlinien untersagen das Nutzen von UL oder CAS zertifizierten Kabeln (mit UL/CSA gekennzeichnet), an Geräten oder Produkten die nicht mit Supermicro gekennzeichnet sind.

¡Advertencia!

Cuando instale el producto, utilice la conexión provista o designada o procure cables, Cables de alimentación y adaptadores de CA que cumplan con los códigos locales y los requisitos de seguridad, incluyendo el tamaño adecuado del cable y el enchufe. El uso de otros cables y adaptadores podría causar un mal funcionamiento o un incendio. La Ley de Seguridad de Aparatos Eléctricos y de Materiales prohíbe El uso de cables certificados por UL o CSA (que tienen el certificado UL / CSA en el código) para cualquier otros dispositivos eléctricos que los productos designados únicamente por Supermicro.

Attention

Lors de l'installation du produit, utilisez les cables de connection fournis ou désigné ou achetez des cables, cables de puissance et adaptateurs respectant les normes locales et les conditions de securite y compris les tailles de cables et les prises electriques appropriées. L'utilisation d'autres cables et adaptateurs peut provoquer un dysfonctionnement ou un incendie. Appareils électroménagers et la Loi sur la Sécurité Matériel interdit l'utilisation de câbles certifiés- UL ou CSA (qui ont UL ou CSA indiqué sur le code) pour tous les autres appareils électriques sauf les produits désignés par Supermicro seulement.

AC ימאתמו מיילמשח מילבכ

!הרהזא

ךרוצל ומאתוה וא ושכרנ רשא AC מימאתמו מיקפס, מילבכב שמתשהל שי, רצומה תא מיניקתמ רשאכ לכב שומיש . עקתהו לבכה לש הנוכח הדימ ללוכ, תוימוקמה תוחיטבה תושירדל ומאתוה רשאו, הנקתהה למשחה ירישכמב שומישה יקוחל מאתהב. ילמשח רצק וא הלקתל מורגל לולע, רחא גוסמ מאתמ וא לבכ לש דוק מהילע עיפומ רשאכ) UL-ב או CSA-ב-ב מיכמסומה מילבכב שמתשהל רוסיא מייק, תוחיטבה יקוחו דבלב Supermicro י"ע מאתוה רשא רצומב קר אלא, רחא ילמשח רצומ לכ רובע (UL/CSA)

תאלבאלא אארשב מץ וא אדדחמלא וא ארפוטמלא תאליטוטלא מאדחטסאב מץ, אגתנמלא בייקרת דנע לכלז יפ אמב אילחמלא אלאסלא תאבלטתמו נינאווקב מאזתלאלא אג דדרתמלא ראיטלא תאלוחמו אילברמלא קיירח וא לטע יפ בבסטטי דץ ירשא תאלוחמו תאלבאלא יא מאדחטסא. מילסלא סבאלאו לטומוא מץ ח. CSA וא UL לביק נמ אדמתמלא תאלבאלא מאדחטסא תאדעמלא אילברמלא אזהאלל אלאסלא נונאק רזחי Supermicro לביק נמ אדדחמלא אילברמלא תאגתנמלא רייג ירשא תאדעמ יא אג (UL/CSA) אלאסלא למחתיטלאו

전원 케이블 및 AC 어댑터

경고! 제품을 설치할 때 현지 코드 및 적절한 굵기의 코드와 플러그를 포함한 안전 요구 사항을 준수하여 제공되거나 지정된 연결 혹은 구매 케이블, 전원 케이블 및 AC 어댑터를 사용하십시오.

다른 케이블이나 어댑터를 사용하면 오작동이나 화재가 발생할 수 있습니다. 전기 용품 안전법은 UL 또는 CSA 인증 케이블 (코드에 UL / CSA가 표시된 케이블)을 Supermicro 가 지정한 제품 이외의 전기 장치에 사용하는 것을 금지합니다.

Stroomkabel en AC-Adapter

Waarschuwing! Bij het aansluiten van het Product uitsluitend gebruik maken van de geleverde Kabels of een andere geschikte aan te schaffen Aansluitmethode, deze moet altijd voldoen aan de lokale voorschriften en veiligheidsnormen, inclusief de juiste kabeldikte en stekker. Het gebruik van niet geschikte Kabels en/of Adapters kan een storing of brand veroorzaken. Wetgeving voor Elektrische apparatuur en Materiaalveiligheid verbied het gebruik van UL of CSA -gecertificeerde Kabels (met UL/CSA in de code) voor elke andere toepassing dan de door Supermicro hiervoor beoogde Producten.

Appendix B

System Specifications

Processors

Single socket 10th Generation Intel® Core™ i9 ~ i3 Processor, Intel® Xeon® W-1200 Processors in LGA-1200; Supports CPU TDP up to 35-80W.

Note: Refer to the motherboard specifications pages on our website for updates to supported processors.

Chipset

Intel® W480E

BIOS

AMI 256Mb SPI Flash EEPROM

Memory

Four DIMM slots, up to 128GB unbuffered ECC/non-ECC UDIMM, ECC DDR4 UDIMM with speeds up to 2933MT/s

Storage Drives

Two 2.5" hot-swap SATA drive bays

One M.2 NVMe or Two M.2 SATA3 (M-Key/E-Key, 2280/22110/2230)

PCI Expansion Slots

One PCIe 3.0 x16 slot HHHL

Input/Output

One RJ45 dedicated IPMI LAN port

Two RJ45 10GBase-T LAN ports

Two RJ45 GbE LAN ports

Four USB 3.0 ports (4 rear)

One VGA port (1 rear)

One DVI-D port

Two display ports with dual-mode

Two SATA3 (6Gbps); RAID 0/1 support

One SuperDOM (Disk on Module) port

Motherboard

X12SCZ-TLN4F; Length 9.6", Width 9.6" (244mm x 244mm)

Chassis

CSE-510FT-203B 1U Rackmount, 1.7 x 17.2 x 11.3in. / 43 x 437 x 287mm (HxWxD)

System Cooling

Four 4cm PWM heavy duty fans with optimal fan speed control

One air shroud

Power Supply

Model: (default) PWS-203-1H 200W module, 80Plus Gold level;

AC Input

200W: 100-240Vac / 2.6A Max / 50-60 Hz

+12V

Max: 16A (100Vac-240Vac) / Min: 0A

Operating Environment

Operating Temperature: 0° to 40° C (41° to 104° F)

Non-operating Temperature: -40° to 70° C (-40° to 158° F)

Operating Relative Humidity: 8% to 90% (non-condensing)

Non-operating Relative Humidity: 5% to 95% (non-condensing)

Regulatory Compliance

FCC, ICES, CE, UKCA, VCCI, RCM, NRTL, CB

Applied Directives, Standards**Perchlorate Warning**

EMC/EMI: 2014/30/EU (EMC Directive)

Electromagnetic Compatibility Regulations 2016

FCC Part 15

ICES-003

VCCI-CISPR 32

AS/NZS CISPR 32

BS/EN 55032

BS/EN 55035

CISPR 32

CISPR 24/CISPR 35

BS/EN 61000-3-2

BS/EN 61000-3-3

BS/EN 61000-4-2

BS/EN 61000-4-3

BS/EN 61000-4-4

BS/EN 61000-4-5

BS/EN 61000-4-6

BS/EN 61000-4-8

BS/EN 61000-4-11

Product Safety: 2014/35/EU (LVD Directive)

UL/CSA 62368-1 (USA and Canada)

Electrical Equipment (Safety) Regulations 2016

IEC/BS/EN 62368-1

Environment:

Delegated Directive (EU) 2015/863

Directive 2011/65/EU (RoHS)

REACH Regulation EC 1907/2006

WEEE Directive 2012/19/EU

California Proposition 65

Warning! This product can expose you to chemicals including lead, known to the State of California to cause cancer and birth defects or other reproductive harm. For more information, go to www.P65Warnings.ca.gov.

Perchlorate Warning

California Best Management Practices Regulations for Perchlorate Materials: This Perchlorate warning applies only to products containing CR (Manganese Dioxide) Lithium coin cells. "Perchlorate Material-special handling may apply. See www.dtsc.ca.gov/hazardouswaste/perchlorate"

BSMI/RoHS

限用物質含有情況標示聲明書

Declaration of the Presence Condition of the Restricted Substances Marking

設備名稱：伺服器/ Server Equipment name 型號（型式）：510F-S2X12 (系列型號: 510 -2, 510F-2, SYS-110C-FHN4T) Type designation (Type)						
單元 Unit	限用物質及其化學符號 Restricted substances and its chemical symbols					
	鉛Lead (Pb)	汞Mercury (Hg)	鎘Cadmium (Cd)	六價鉻Hexavalent chromium (Cr ⁺⁶)	多溴聯苯Polybrominated biphenyls (PBB)	多溴二苯醚Polybrominated diphenyl ethers (PBDE)
機殼 (Chassis)	○	○	○	○	○	○
機殼風扇 (Chassis Fan)	—	○	○	○	○	○
線材 (Cable)	○	○	○	○	○	○
主機板 (Motherboard)	—	○	○	○	○	○
電源供應器 (Power Supply)	—	○	○	○	○	○
硬碟 (HDD)	—	○	○	○	○	○
電源背板 (PDB)	—	○	○	○	○	○
備考1. “超出0.1 wt %”及“超出0.01 wt %”係指限用物質之百分比含量超出百分比含量基準值。 Note 1 : “Exceeding 0.1 wt %” and “exceeding 0.01 wt %” indicate that the percentage content of the restricted substance exceeds the reference percentage value of presence condition.						
備考2. “○”係指該項限用物質之百分比含量未超出百分比含量基準值。 Note 2 : “○” indicates that the percentage content of the restricted substance does not exceed the percentage of reference value of presence.						
備考3. “—”係指該項限用物質為排除項目。 Note 3 : The “—” indicates that the restricted substance corresponds to the exemption.						

警告：為避免電磁干擾，本產品不應安裝或使用於住宅環境。

輸入額定：

100-240V ~, 60-50Hz, 2.6A max

*使用者不能任意拆除或替換內部配備

*報驗義務人之姓名或名稱：美超微電腦股份有限公司

*報驗義務人之地址：新北市中和區建一路 150 號 3 樓