



A+ Server<sup>®</sup>  
AS -1015SV-WTNRT



USER'S MANUAL

Revision 1.0

The information in this User's Manual has been carefully reviewed and is believed to be accurate. The vendor assumes no responsibility for any inaccuracies that may be contained in this document, and makes no commitment to update or to keep current the information in this manual, or to notify any person or organization of the updates. Please Note: For the most up-to-date version of this manual, please see our website at [www.supermicro.com](http://www.supermicro.com).

Super Micro Computer, Inc. ("Supermicro") reserves the right to make changes to the product described in this manual at any time and without notice. This product, including software and documentation, is the property of Supermicro and/or its licensors, and is supplied only under a license. Any use or reproduction of this product is not allowed, except as expressly permitted by the terms of said license.

IN NO EVENT WILL Super Micro Computer, Inc. BE LIABLE FOR DIRECT, INDIRECT, SPECIAL, INCIDENTAL, SPECULATIVE OR CONSEQUENTIAL DAMAGES ARISING FROM THE USE OR INABILITY TO USE THIS PRODUCT OR DOCUMENTATION, EVEN IF ADVISED OF THE POSSIBILITY OF SUCH DAMAGES. IN PARTICULAR, SUPER MICRO COMPUTER, INC. SHALL NOT HAVE LIABILITY FOR ANY HARDWARE, SOFTWARE, OR DATA STORED OR USED WITH THE PRODUCT, INCLUDING THE COSTS OF REPAIRING, REPLACING, INTEGRATING, INSTALLING OR RECOVERING SUCH HARDWARE, SOFTWARE, OR DATA.

Any disputes arising between manufacturer and customer shall be governed by the laws of Santa Clara County in the State of California, USA. The State of California, County of Santa Clara shall be the exclusive venue for the resolution of any such disputes. Supermicro's total liability for all claims will not exceed the price paid for the hardware product.

FCC Statement: This equipment has been tested and found to comply with the limits for a Class A or Class B digital device pursuant to Part 15 of the FCC Rules. These limits are designed to provide reasonable protection against harmful interference when the equipment is operated in industrial environment for Class A device or in residential environment for Class B device. This equipment generates, uses, and can radiate radio frequency energy and, if not installed and used in accordance with the manufacturer's instruction manual, may cause harmful interference with radio communications. Operation of this equipment in a residential area is likely to cause harmful interference, in which case you will be required to correct the interference at your own expense.

California Best Management Practices Regulations for Perchlorate Materials: This Perchlorate warning applies only to products containing CR (Manganese Dioxide) Lithium coin cells. "Perchlorate Material-special handling may apply. See [www.dtsc.ca.gov/hazardouswaste/perchlorate](http://www.dtsc.ca.gov/hazardouswaste/perchlorate)".



WARNING: This product can expose you to chemicals including lead, known to the State of California to cause cancer and birth defects or other reproductive harm. For more information, go to [www.P65Warnings.ca.gov](http://www.P65Warnings.ca.gov).

The products sold by Supermicro are not intended for and will not be used in life support systems, medical equipment, nuclear facilities or systems, aircraft, aircraft devices, aircraft/emergency communication devices or other critical systems whose failure to perform be reasonably expected to result in significant injury or loss of life or catastrophic property damage. Accordingly, Supermicro disclaims any and all liability, and should buyer use or sell such products for use in such ultra-hazardous applications, it does so entirely at its own risk. Furthermore, buyer agrees to fully indemnify, defend and hold Supermicro harmless for and against any and all claims, demands, actions, litigation, and proceedings of any kind arising out of or related to such ultra-hazardous use or sale.

Manual Revision 1.0

Release Date: December 27, 2023

Unless you request and receive written permission from Super Micro Computer, Inc., you may not copy any part of this document. Information in this document is subject to change without notice. Other products and companies referred to herein are trademarks or registered trademarks of their respective companies or mark holders.

Copyright © 2023 by Super Micro Computer, Inc.  
All rights reserved.

**Printed in the United States of America**

# Preface

## About this Manual

This manual is written for professional system integrators and PC technicians. It provides information for the installation and use of the server. Installation and maintenance should be performed by certified service technicians only.

Please refer to the AS -1015SV-WTNRT server specifications page on our website for updates on supported memory, processors and operating systems (<http://www.supermicro.com>).

## Notes

For your system to work properly, please follow the links below to download all necessary drivers/utilities and the user's manual for your server.

- Supermicro product manuals: <http://www.supermicro.com/support/manuals/>
- Product drivers and utilities: <https://www.supermicro.com/wdl>
- Product safety info: [http://www.supermicro.com/about/policies/safety\\_information.cfm](http://www.supermicro.com/about/policies/safety_information.cfm)

If you have any questions, please contact our support team at:

[support@supermicro.com](mailto:support@supermicro.com)

This manual may be periodically updated without notice. Please check the Supermicro website for possible updates to the manual revision level.

## Secure Data Deletion

A secure data deletion tool designed to fully erase all data from storage devices can be found on our website: [https://www.supermicro.com/about/policies/disclaimer.cfm?url=/wdl/utility/Lot9\\_Secure\\_Data\\_Deletion\\_Utility/](https://www.supermicro.com/about/policies/disclaimer.cfm?url=/wdl/utility/Lot9_Secure_Data_Deletion_Utility/)

## Warnings

Special attention should be given to the following symbols used in this manual.



**Warning!** Indicates important information given to prevent equipment/property damage or personal injury.



**Warning!** Indicates high voltage may be encountered when performing a procedure.

# Contents

## **Chapter 1 Introduction**

1.1 Overview.....	9
1.2 System Features .....	10
Front View .....	10
Drive Carrier Indicators .....	11
Control Panel.....	12
Rear View.....	13
1.3 System Architecture .....	15
Main Components .....	15
1.4 System Block Diagram.....	16
1.5 Motherboard Layout .....	17
Quick Reference Table.....	18

## **Chapter 2 Server Installation**

2.1 Overview.....	19
2.2 Unpacking the System .....	19
2.3 Preparing for Setup.....	19
Choosing a Setup Location.....	19
Rack Precautions .....	20
Server Precautions.....	20
Rack Mounting Considerations .....	20
Ambient Operating Temperature.....	20
Airflow .....	21
Mechanical Loading.....	21
Circuit Overloading .....	21
Reliable Ground.....	21
2.4 Installing the Rails .....	22
Identifying the Rails.....	22
2.5 Installing the Chassis into the Rack.....	25
Removing the Chassis from the Rack .....	26

## **Chapter 3 Maintenance and Component Installation**

3.1 Removing Power .....	27
3.2 Accessing the System.....	28

---

---

3.3 Processor and Heatsink Installation.....	29
3.4 Memory Support and Installation .....	36
Memory Support.....	36
DIMM Module Population.....	37
DIMM Installation .....	38
DIMM Removal .....	38
3.5 Motherboard Battery.....	39
3.6 Storage Drives.....	40
Installing Drives.....	40
Installing M.2 Solid State Drives .....	43
To Install M.2 SSDs.....	43
3.7 System Cooling .....	44
Fans .....	44
Installing or Removing Air Shroud .....	45
3.8 Power .....	46
Redundant Power Supply System .....	46
Power Supply LEDs.....	46
Power Supply Module .....	47
3.9 PCIe Expansion Cards.....	48
3.10 Cable Routing Diagram.....	50
4x SATA (Default).....	50
4x SATA/NVMe Hybrid.....	51
4x SATA/SAS via AOC 3808/3908.....	52
<b>Chapter 4 Motherboard Connections</b>	
4.1 Power Connections .....	53
Power Connections .....	53
4.2 Headers and Connectors .....	54
4.3 Input/Output Ports .....	58
Rear I/O Ports.....	58
4.4 Jumper Settings .....	60
How Jumpers Work.....	60
4.5 LED Indicators.....	62

---

---

**Chapter 5 Software**

5.1 Microsoft Windows OS Installation.....	64
5.2 Driver Installation.....	66
5.3 SuperDoctor® 5.....	67
5.4 BMC.....	68
BMC ADMIN User Password .....	68

**Chapter 6 Optional Components**

6.1 Storage Drive Options.....	69
6.2 Storage Control Cards .....	69
6.3 TPM Security Module.....	70

**Chapter 7 Troubleshooting and Support**

7.1 Information Resources .....	71
Website .....	71
Direct Links for the AS -1015SV-WTNRT System.....	71
Direct Links for General Support and Information .....	71
7.2 Baseboard Management Controller (BMC).....	72
7.3 Troubleshooting Procedures .....	73
Before Power On .....	73
No Power .....	73
No Video .....	73
System Boot Failure .....	74
Memory Errors .....	74
Losing the System Setup Configuration .....	74
When the System Becomes Unstable .....	74
7.4 BIOS Error Beep (POST) Codes .....	76
Additional BIOS POST Codes .....	76
7.5 Crash Dump Using BMC.....	77
7.6 UEFI BIOS Recovery .....	78
Overview .....	78
Recovering the UEFI BIOS Image.....	78
Recovering the Main BIOS Block with a USB Device.....	78
7.7 CMOS Clear .....	81
7.8 Where to Get Replacement Components.....	81
7.9 BMC Reset.....	82

7.10 Reporting an Issue .....82  
    Technical Support Procedures .....82  
    Returning Merchandise for Service.....83  
7.11 Feedback.....83

***Appendix A Standardized Warning Statements for AC Systems***

***Appendix B System Specifications***

## Contacting Supermicro

### Headquarters

Address: Super Micro Computer, Inc.  
980 Rock Ave.  
San Jose, CA 95131 U.S.A.

Tel: +1 (408) 503-8000

Fax: +1 (408) 503-8008

Email: [marketing@supermicro.com](mailto:marketing@supermicro.com) (General Information)  
[Sales-USA@supermicro.com](mailto:Sales-USA@supermicro.com) (Sales Inquiries)  
[Government\\_Sales-USA@supermicro.com](mailto:Government_Sales-USA@supermicro.com) (Gov. Sales Inquiries)  
[support@supermicro.com](mailto:support@supermicro.com) (Technical Support)  
[RMA@supermicro.com](mailto:RMA@supermicro.com) (RMA Support)  
[Webmaster@supermicro.com](mailto:Webmaster@supermicro.com) (Webmaster)

Website: [www.supermicro.com](http://www.supermicro.com)

### Europe

Address: Super Micro Computer B.V.  
Het Sterrenbeeld 28, 5215 ML  
's-Hertogenbosch, The Netherlands

Tel: +31 (0) 73-6400390

Fax: +31 (0) 73-6416525

Email: [Sales\\_Europe@supermicro.com](mailto:Sales_Europe@supermicro.com) (Sales Inquiries)  
[Support\\_Europe@supermicro.com](mailto:Support_Europe@supermicro.com) (Technical Support)  
[RMA\\_Europe@supermicro.com](mailto:RMA_Europe@supermicro.com) (RMA Support)

Website: [www.supermicro.nl](http://www.supermicro.nl)

### Asia-Pacific

Address: Super Micro Computer, Inc.  
3F, No. 150, Jian 1st Rd.  
Zhonghe Dist., New Taipei City 235  
Taiwan (R.O.C)

Tel: +886-(2) 8226-3990

Fax: +886-(2) 8226-3992

Email: [Sales-Asia@supermicro.com.tw](mailto:Sales-Asia@supermicro.com.tw) (Sales Inquiries)  
[Support@supermicro.com.tw](mailto:Support@supermicro.com.tw) (Technical Support)  
[RMA@supermicro.com.tw](mailto:RMA@supermicro.com.tw) (RMA Support)

Website: [www.supermicro.com.tw](http://www.supermicro.com.tw)

# Chapter 1

## Introduction

### 1.1 Overview

This chapter provides a brief outline of the functions and features of the A+ Server AS -1015SV-WTNRT. It is based on the H13SVW-NT motherboard and the CSE-815BTS-R000WNP chassis.

The following provides an overview of the specifications and capabilities.

System Overview	
<b>Motherboard</b>	H13SVW-NT
<b>Chassis</b>	CSE-815BTS-R000WNP
<b>Processor Support</b>	Single AMD EPYC™ 8004 Series processor in SP6 socket with up to 64 cores; CPU TDP supports up to 225 W
<b>Memory</b>	Six DIMM slots support up to 576 GB of registered ECC DDR5-4800 MT/s SDRAM memory
<b>Drive Support</b>	Four hot-swap 3.5" drive bays support SATA (default)/NVMe*/SAS* drives Two PCIe 3.0 x2 M.2 in 22110 or 2280 form factor <b>*Note:</b> Additional parts are required for NVMe and SAS drive support.
<b>Expansion Slots</b>	Two PCIe 5.0 x16 (FHFL) One PCIe 5.0 x16 (LP)
<b>I/O Ports</b>	One dedicated IPMI LAN port Two 10 GbE LAN ports via Broadcom (BCM57416) Four USB 3.0 ports (rear) One COM port One VGA port One TPM 2.0 header
<b>System Cooling</b>	Six 40 x 40 x 56 mm counter rotating PWM fans One passive heatsink for 1U system One air shroud
<b>Power</b>	Dual 860 W Titanium high-efficiency redundant power supply modules (Full redundancy based on configuration and application load)
<b>Form Factor</b>	1U (WxHxD) 17.2" x 1.7" x 25.6" (436.9 x 43.2 x 650.2 mm)

**Notes:** A Quick Reference Guide can be found on the [product page](#) of the Supermicro website. The following safety models associated with the AS -1015SV-WTNRT have been certified as compliant with CSA or UL models: 815-R8H13, 815-8.

## 1.2 System Features

The following views of the system display the main features. Refer to [Appendix B](#) for additional specifications.

### Front View



Figure 1-1. Front View

System Features: Front	
Item	Description
Service Tag	Service or asset tag has the BMC password details
Control Panel	Front control panel with LEDs and buttons (See <a href="#">Control Panel</a> for details.)

Storage Drive Numbers	
Item	Description
0-3	Four 3.5" hot-swap SATA/NVMe*/SAS* drive bays

**\*Note:** Additional parts are required for NVMe and SAS drive support. See [3.10 Cable Routing Diagram](#) for more details.

## Drive Carrier Indicators

Each drive carrier has two LED indicators: an activity indicator and a status indicator. For RAID configurations using a controller, the meaning of the status indicator is described in the table below.

Drive Carrier LED Indicator			
	Color	Blinking Pattern	Behavior for Device
<b>Activity LED</b>	Blue	Solid On	Idle SAS/NVMe drive installed
	Blue	Blinking	I/O activity
	Off		Idle SATA drive installed or no drive
<b>Status LED</b>	Red	Solid On	Drive failed
	Red	Blinking at 1 Hz	Rebuilding drive
	Red	Blinking with two blinks and one stop at 1 Hz	Hot spare for drive
	Red	On for five seconds, then off	Power on for drive
	Red	Blinking at 4 Hz	Identifying drive

## Control Panel

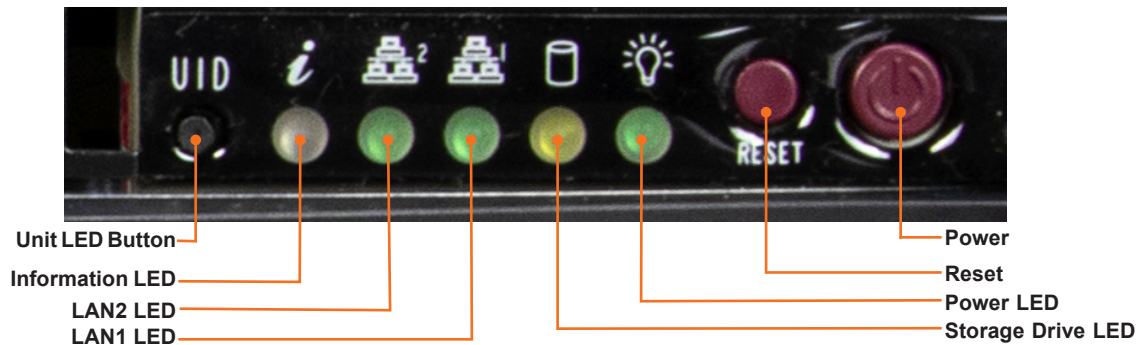

Figure 1-2. Control Panel

Control Panel Features	
Feature	Description
UID LED Button	Push this button to turn on the blue UID LED indicators both at the front and at the rear. This helps in identifying the unit when requiring service, especially when it is part of a large installation. The BMC can be reset using the UID switch
Information LED	Alerts operator to several states, as noted in the table below.
LAN2 LED	Indicates network activity on LAN port 2 when flashing.
LAN1 LED	Indicates network activity on LAN port 1 when flashing.
Storage Drive LED	Indicates activity on the storage drives when flashing.
Power LED	Steady on – Power on Blinking at 4 Hz – Checking BIOS/BMC integrity Blinking at 4 Hz and "i" LED is blue – BIOS firmware updating Two blinks at 4 Hz, one pause 2hz and "i" LED blue – BMC firmware updating Blinking at 1 Hz and "i" LED red – Fault detected
Reset Button	Reboot the system
Power Button	The main power switch applies or removes primary power from the power supply to the server but maintains standby power. Hold for four seconds to force a shut-down.

Information LED	
Color, Status	Description
Red, solid	An overheat condition has occurred.
Red, blinking at 1 Hz	Fan failure, check for an inoperative fan.
Red, blinking at 0.25 Hz	Power failure, check for a non-operational power supply.
Red, solid, with Power LED blinking green	Fault detected
Blue and red, blinking at 10 Hz	Recovery mode
Blue, solid	UID has been activated locally to locate the server in a rack environment.
Blue, blinking at 1 Hz	UID has been activated using the BMC to locate the server in a rack environment.
Blue, blinking at 2 Hz	BMC is resetting
Blue, blinking at 4 Hz	BMC is setting factory defaults
Blue, blinking at 10 Hz with Power LED blinking green	BMC/BIOS firmware is updating

## Rear View

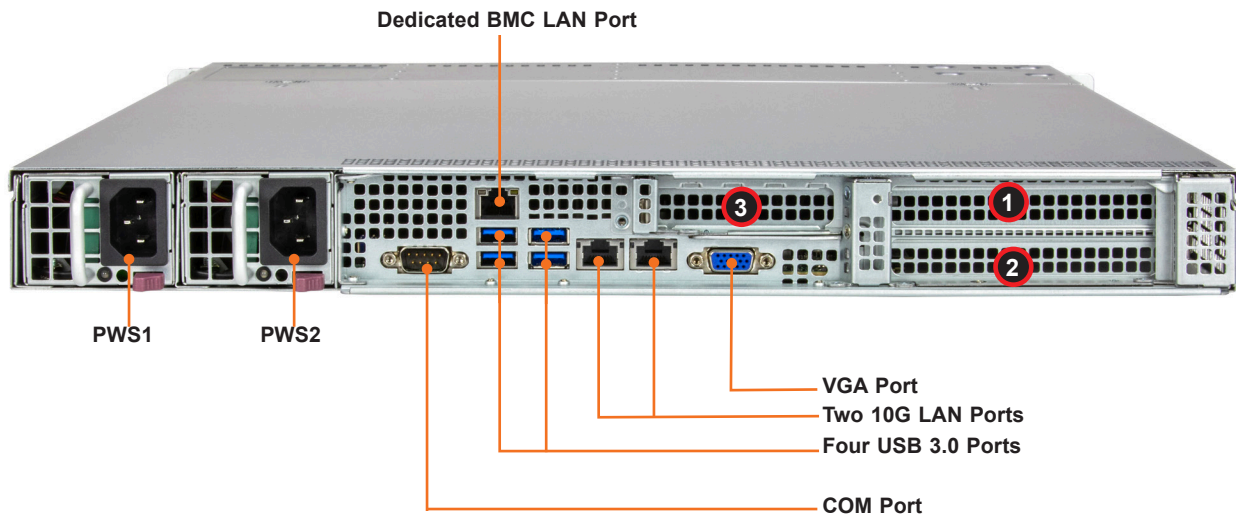

Figure 1-3. System: Rear View

System Features: Rear	
Feature	Description
Power Supplies	Two redundant power supply modules. PWS1 on the left and PWS2 on the right.
COM Port	One serial port
BMC LAN Port	One dedicated BMC LAN port
USB 3.0 ports	Four USB 3.0 ports
VGA Port	One VGA video port
LAN Ports	Two RJ45 LAN ports (with Broadcom 10 GbE BaseT)

Expansion Card Slots	
Item	Description
①	One PCIe 5.0 x16 full-height full-length expansion slot
②	One PCIe 5.0 x16 full-height full-length expansion slot
③	One PCIe 5.0 x16 low profile expansion slot

**Note:** Full height = 4.2", full length = 10.5", low profile = 2.5"

<b>Power Supply Indicators</b>		
<b>Power Supply Condition</b>	<b>Green LED</b>	<b>Amber LED</b>
No AC Power to Power Supply	OFF	OFF
Power Supply critical events causing a shutdown/ failure/ OCP/ OVP/ Fan Fail/ OTP/ UVP	OFF	ON
Power Supply Warning Events Where the power supply continues to operate; High temperature; Over voltage; under voltage, etc.	OFF	1 Hz Blinking
AC present only 12 VSB ON (PS OFF)	1 Hz Blinking	OFF
Output ON and OK	ON	OFF
One of the power cords unplugged and in redundant mode	OFF	ON

## 1.3 System Architecture

This section shows the locations of the system's main components.

### Main Components

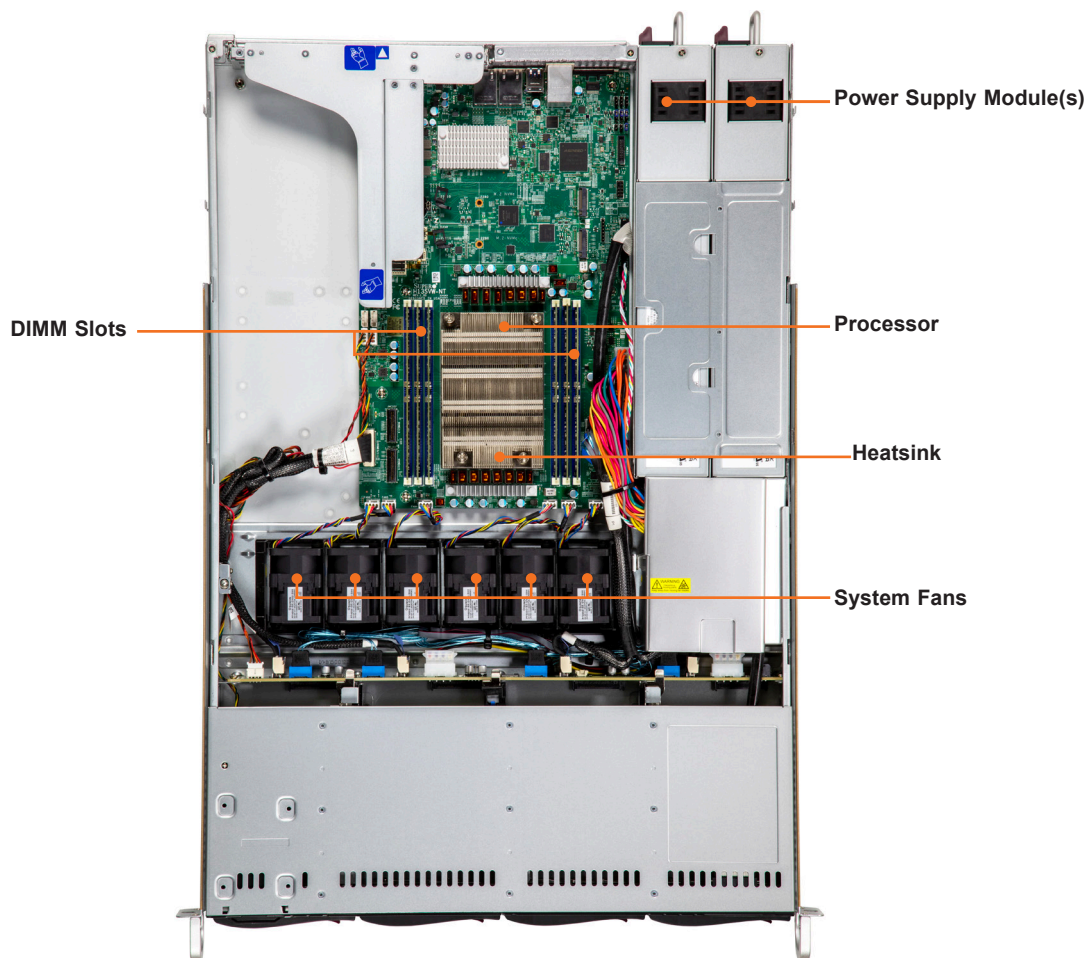

Figure 1-4. System: Top View

System Features: Top	
Feature	Description
Power Supply	Dual 860 W Titanium high-efficiency redundant power supply modules
Motherboard	H13SVW-NT
DIMM slots	Six DDR5 DIMM slots
Processor	Single AMD EPYC™ 8004 Series processor in one SP6 socket
Heatsink	One passive heatsink (SNK-P0062P-1)
System fans	Six internal counter-rotating fans (FAN-0163L4)

# 1.4 System Block Diagram

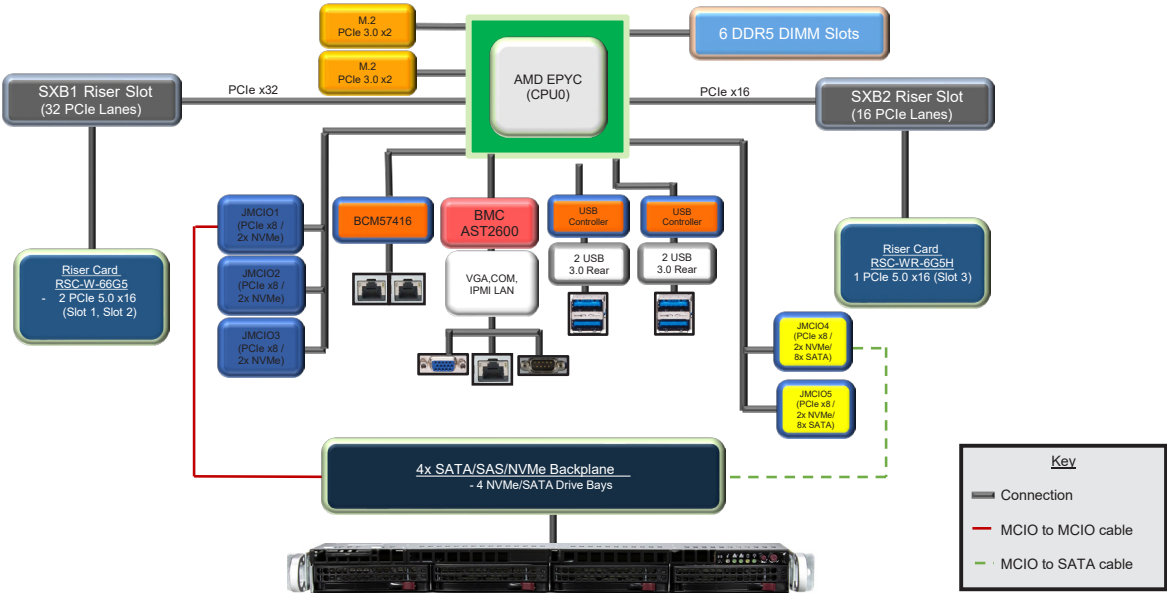

Figure 1-5. Motherboard Block Diagram

## 1.5 Motherboard Layout

Below is a layout of the H13SVW-NT motherboard with jumper, connector and LED locations shown. See the table on the following page for descriptions. For detailed descriptions, pinout information and jumper settings, refer to [Chapter 4](#) or the [Motherboard Manual](#).

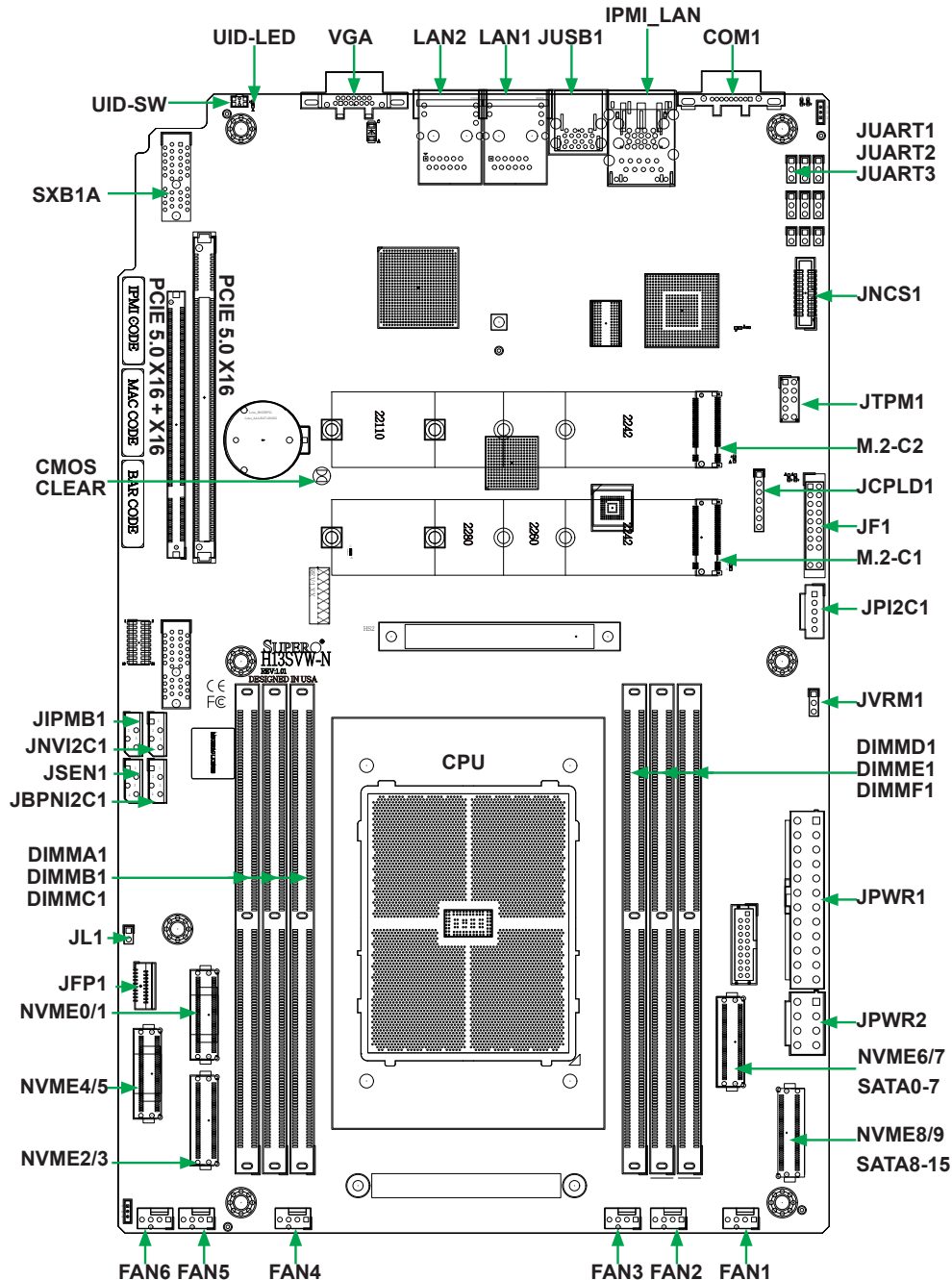

Figure 1-6. Motherboard Layout

### Notes:

- Jumpers/LED indicators not indicated are used for testing only.
- Use only the correct type of onboard CMOS battery as specified by the manufacturer. To avoid possible explosion, do not install the onboard battery upside down.

## Quick Reference Table

Jumper	Description	Default Setting
JBT1	Clear CMOS	Open (Normal)
JPL1	LAN enable/disable	Pins 1-2 (Enabled)
JSATA1	Hybrid MCIO select for JMCIO4	Pins 1-2 (Auto)
JSATA2	Hybrid MCIO select for JMCIO5	Pins 1-2 (Auto)
UID SW	Unit ID switch (push-button toggle switch ON/OFF)	Off

LED	Description	Status
LEDBMC	BMC Heartbeat	Blinking: BMC Normal/Working
LED8	Power LED	On: Power On
LED9	UID LED	Blue: UID Activated

Connector	Description
Battery (BT1)	Onboard CMOS battery
COM 1	Rear panel COM port 1
FAN 1~6	System cooling fan headers
JF1	Front control panel
JIPMB1	4-pin external BMC I2C header (for an IPMI card)
JL1	Chassis intrusion header
JPI2C1	PWR supply (I2C) System Management Bus
JPWR1	24-pin ATX power supply connector
JPWR2	12V 8-pin ATX CPU power connector
JSXB1A, JSXB1B, JSXB1C, JSXB2	Slots for Supermicro riser cards
JTPM1	Trusted Platform Module (TPM)/Port 80 connector
LAN1, LAN2	Back panel LAN1, LAN2 connectors
M.2-C1, M.2-C2	M.2 slots
NVMe0~5	NVMe slots 0~5
USB 0/1 (3.0)	Back panel USB 3.0 ports (USB 0/1)
USB 2/3 (3.0)	Back panel USB 3.0 ports (USB 2/3)
USB 4/5 (3.0)	Internal USB 3.0 header (USB 4/5)
VGA	Back panel VGA port

**Note:** Jumpers, connectors, switches, and LED indicators that are not described in the preceding tables are for manufacturing testing purposes only, and are not covered in this manual.

# Chapter 2

## Server Installation

### 2.1 Overview

This chapter provides advice and instructions for mounting your system in a server rack. If your system is not already fully integrated with processors, system memory etc., refer to [Chapter 3](#) for details on installing those specific components.

**Caution:** Electrostatic Discharge (ESD) can damage electronic components. To prevent such damage to PCBs (printed circuit boards), it is important to use a grounded wrist strap, handle all PCBs by their edges and keep them in anti-static bags when not in use.

### 2.2 Unpacking the System

Inspect the box in which the A+ Server AS -1015SV-WTNRT was shipped, and note if it was damaged in any way. If any equipment appears damaged, file a damage claim with the carrier who delivered it.

Decide on a suitable location for the rack unit that will hold the server. It should be situated in a clean, dust-free area that is well ventilated. Avoid areas where heat, electrical noise and electromagnetic fields are generated. It will also require a grounded AC power outlet nearby. Be sure to read the precautions and considerations noted in [Appendix A](#).

### 2.3 Preparing for Setup

The box in which the system was shipped should include the rackmount hardware needed to install it into the rack. Please read this section in its entirety before you begin the installation.

#### Choosing a Setup Location

- The system should be situated in a clean, dust-free area that is well ventilated. Avoid areas where heat, electrical noise and electromagnetic fields are generated.
- Leave enough clearance in front of the rack so that you can open the front door completely (~25 inches) and approximately 30 inches of clearance in the back of the rack to allow sufficient space for airflow and access when servicing.
- This product should be installed only in a Restricted Access Location (dedicated equipment rooms, service closets, etc.).

- This product is not suitable for use with visual display workplace devices according to §2 of the German Ordinance for Work with Visual Display Units.

## Rack Precautions

- Ensure that the leveling jacks on the bottom of the rack are extended to the floor so that the full weight of the rack rests on them.
- In single rack installations, stabilizers should be attached to the rack. In multiple rack installations, the racks should be coupled together.
- Always make sure the rack is stable before extending a server or other component from the rack.
- You should extend only one server or component at a time - extending two or more simultaneously may cause the rack to become unstable.

## Server Precautions

- Review the electrical and general safety precautions in [Appendix A](#).
- Determine the placement of each component in the rack *before* you install the rails.
- Install the heaviest server components at the bottom of the rack first and then work your way up.
- Use a regulating uninterruptible power supply (UPS) to protect the server from power surges and voltage spikes and to keep your system operating in case of a power failure.
- Allow any drives and power supply modules to cool before touching them.
- When not servicing, always keep the front door of the rack and all covers/panels on the servers closed to maintain proper cooling.

## Rack Mounting Considerations

### *Ambient Operating Temperature*

If installed in a closed or multi-unit rack assembly, the ambient operating temperature of the rack environment may be greater than the room's ambient temperature. Therefore, consideration should be given to installing the equipment in an environment compatible with the manufacturer's maximum rated ambient temperature (TMRA).

### ***Airflow***

Equipment should be mounted into a rack so that the amount of airflow required for safe operation is not compromised.

### ***Mechanical Loading***

Equipment should be mounted into a rack so that a hazardous condition does not arise due to uneven mechanical loading.

### ***Circuit Overloading***

Consideration should be given to the connection of the equipment to the power supply circuitry and the effect that any possible overloading of circuits might have on overcurrent protection and power supply wiring. Appropriate consideration of equipment nameplate ratings should be used when addressing this concern.

### ***Reliable Ground***

A reliable ground must be maintained at all times. To ensure this, the rack itself should be grounded. Particular attention should be given to power supply connections other than the direct connections to the branch circuit (i.e. the use of power strips, etc.).



To prevent bodily injury when mounting or servicing this unit in a rack, you must take special precautions to ensure that the system remains stable. The following guidelines are provided to ensure your safety:

- This unit should be mounted at the bottom of the rack if it is the only unit in the rack.
- When mounting this unit in a partially filled rack, load the rack from the bottom to the top with the heaviest component at the bottom of the rack.
- If the rack is provided with stabilizing devices, install the stabilizers before mounting or servicing the unit in the rack.
- Slide rail mounted equipment is not to be used as a shelf or a work space.

## 2.4 Installing the Rails

There are a variety of rack units on the market, which may require a slightly different assembly procedure. This rail set (MCP-290-00054-0N) fits a rack between 25.6" and 33" deep.

The following is a basic guideline for installing the system into a rack with the rack mounting hardware provided. You should also refer to the installation instructions that came with the specific rack you are using.

### Identifying the Rails

The chassis comes with two sets of rack rails, one set for the right side of the chassis and one for the left. Each set consists of an inner rail that is pre-attached to the chassis, and an outer rail that attaches to the rack.

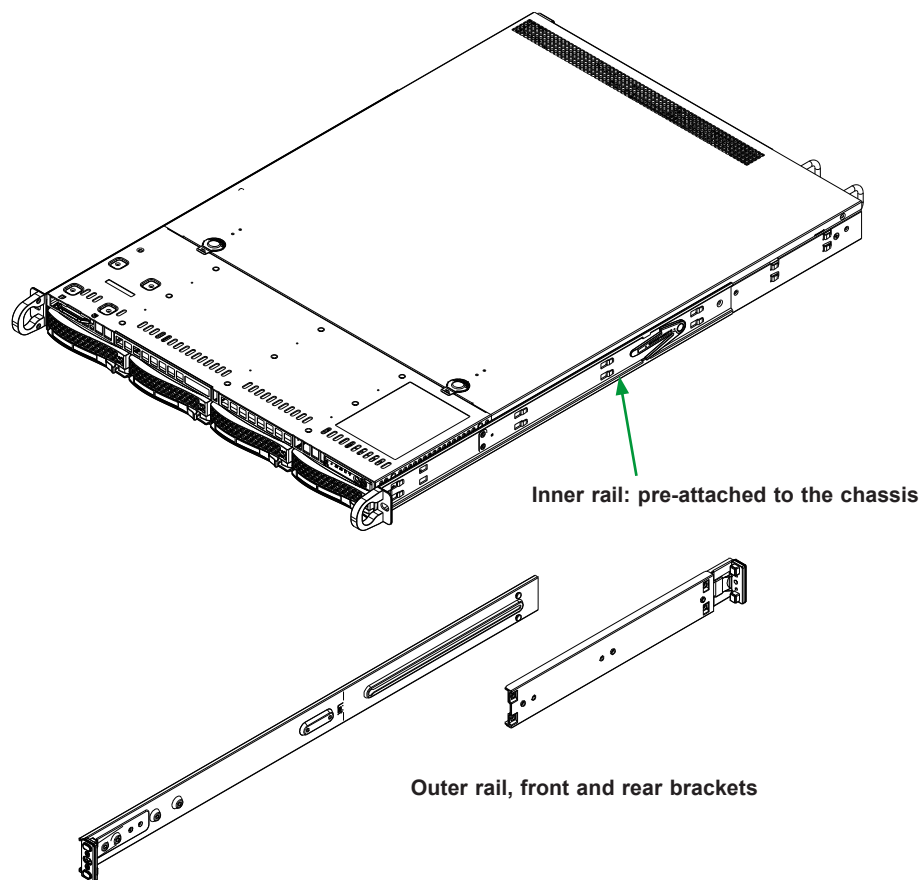

Figure 2-1. Identifying the Sections of the Rack Rails



**Warning:** do not pick up the server by the front handles. They are designed to pull the system from a rack only.

### ***Installing the Outer Rails***

1. Measure the distance from the front rail of the rack to the rear rail of the rack.
2. Attach a short bracket to the rear side of the right outer rail, and a long bracket to the front side of the right outer rail as shown above on the right.
3. Adjust the short and long brackets to the proper distance so that the chassis can snugly fit into the rack.
4. Secure the rails to the cabinet with screws. Repeat steps 1-4 for the left outer rail.

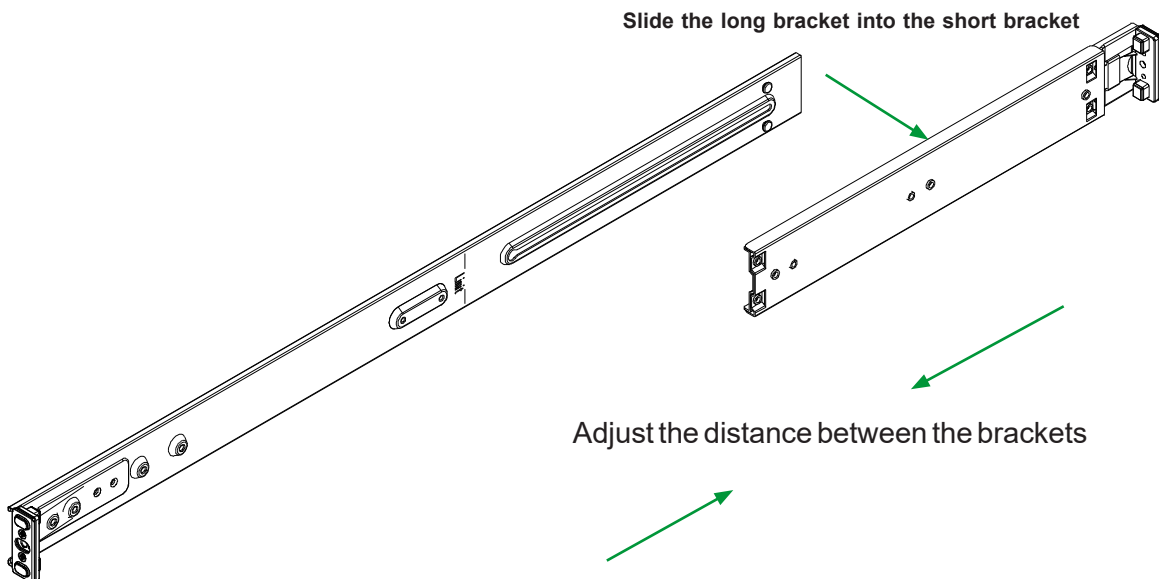

**Figure 2-2. Extending and Mounting the Outer Rails**

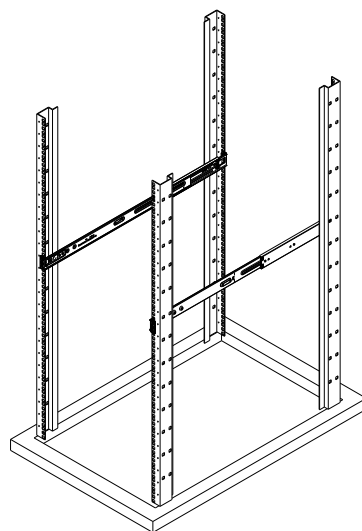

**Figure 2-3. Installing the Outer Rails to the Rack**

### ***Installing the Rail Assemblies to the Rack***

1. After you have installed the short and long brackets to the outer rails, you are ready to install the whole rail assemblies (outer rails with short and long brackets attached) to the rack. (See the previous page.)
2. Use M5 screws and washers to secure the rail assemblies into the rack as shown below.

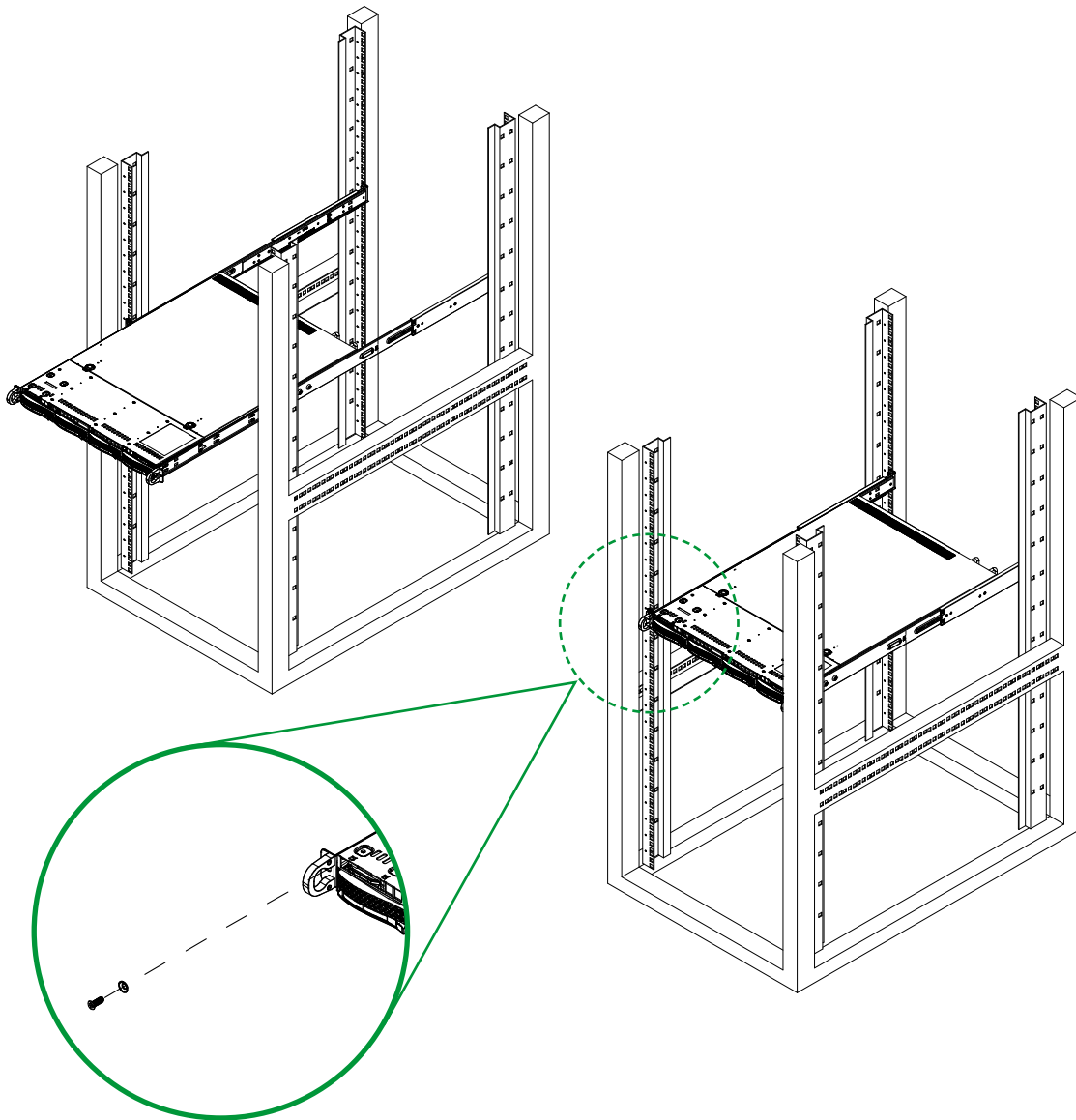

**Figure 2-4. Securing the Rail Assemblies to the Rack**

**Note:** Figure is for illustrative purposes only. Always install servers to the bottom of a rack first.

## 2.5 Installing the Chassis into the Rack

Once rails are attached to the chassis and the rack, the chassis is ready to be installed into a rack.

1. Push the inner slides, which are attached to the chassis, into the grooves of the outer slide assemblies that are installed in the rack as shown below.

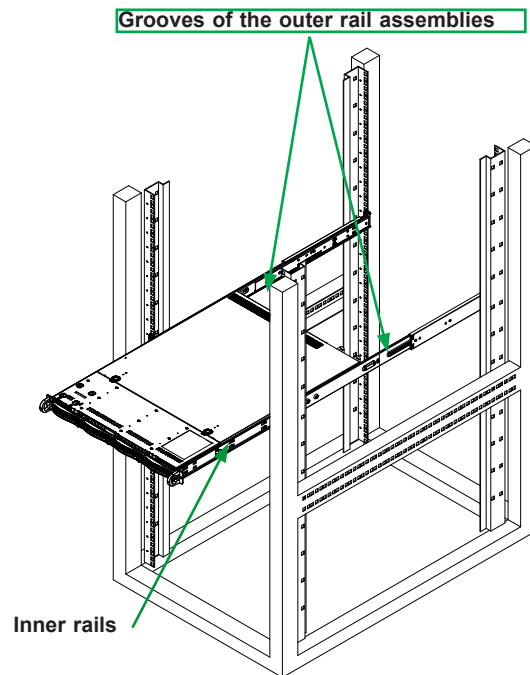

2. Slide the chassis rails into the rack rails until the chassis is completely in the rack.

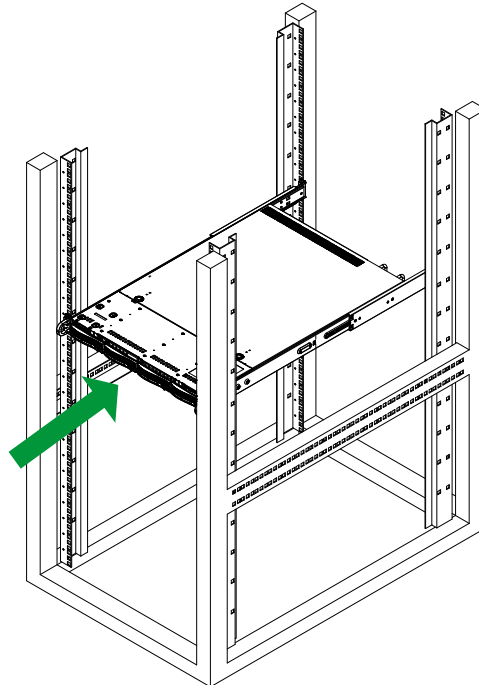

**Note:** Figure is for illustrative purposes only. Always install servers to the bottom of a rack first.

## Removing the Chassis from the Rack

**Caution!** It is dangerous for a single person to off-load the heavy chassis from the rack without assistance. Be sure to have sufficient assistance supporting the chassis when removing it from the rack. Use a lift.

1. Pull the chassis forward out the front of the rack until it stops.
2. Press the release latches on each of the inner rails downward simultaneously and continue to pull the chassis forward and out of the rack.

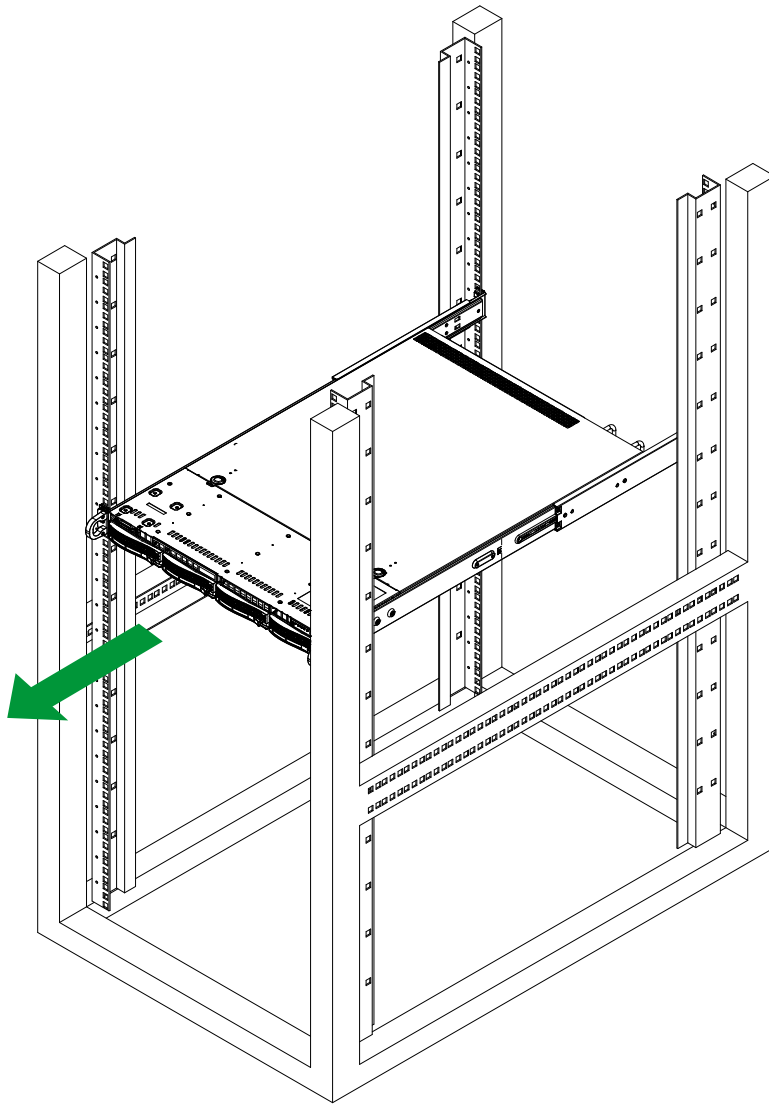

**Figure 2-5. Removing the Chassis from the Rack**

**Note:** Figure is for illustrative purposes only. Always install servers to the bottom of a rack first.

## Chapter 3

# Maintenance and Component Installation

This chapter provides instructions on installing and replacing main system components. To prevent compatibility issues, only use components that match the specifications and/or part numbers given.

Installation or replacement of most components require that power first be removed from the system. Please follow the procedures given in each section.

### 3.1 Removing Power

Use the following procedure to ensure that power has been removed from the system. This step is required when removing or installing non hot-swap components or when replacing a non-redundant power supply.

1. Use the operating system to power down the system.
2. After the system has completely shut-down, disconnect the AC power cords from the power strip or outlet. (If your system has more than one power supply, remove the AC power cords from all power supply modules.)
3. Disconnect the power cords from the power supply modules.

## 3.2 Accessing the System

*The chassis features a removable top cover for access to the internal components. When performing service on components inside the system, remove the system from the rack and place it on a work bench or desk. Do not service with the system extended from the rack.*

### Removing the Top Cover from the Chassis

Before installing any components, replacing chassis fans or accessing the motherboard, you will first need to remove the top cover from the chassis.

1. Remove the power cords from the rear of the power supplies as described in section [3.1](#).

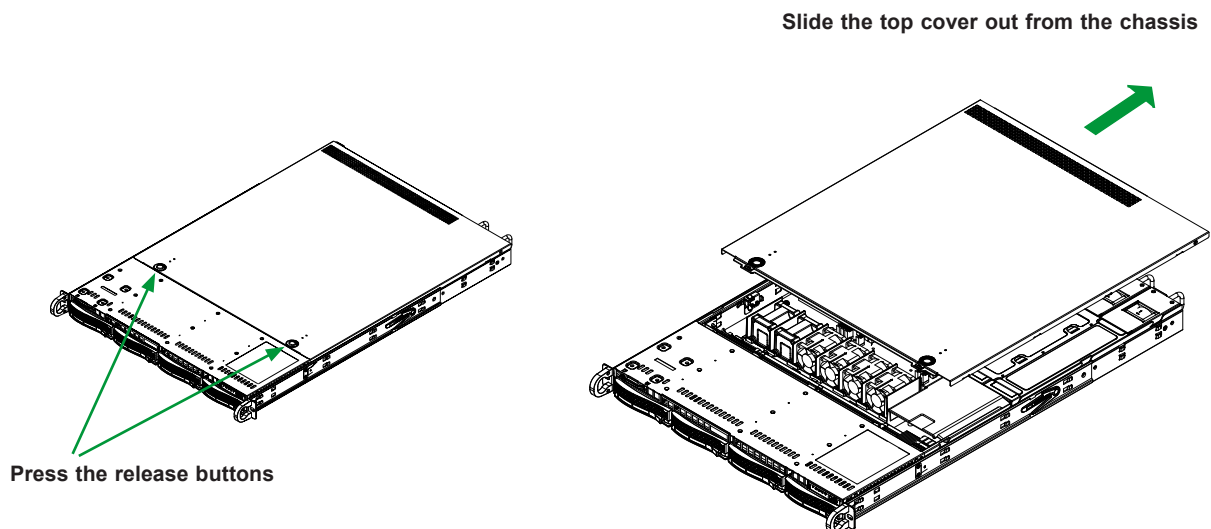

**Figure 3-1. Removing Top Cover**

2. Simultaneously press both the release tabs to release the top cover from its locking position.
3. Slide the cover back toward the rear of the chassis as shown below.
4. Lift the top cover upwards and off of the chassis.

Check that all ventilation openings on the top cover and the top of the chassis are clear and unobstructed.



**Warning:** Except for short periods of time, do NOT operate the server without the cover in place. The chassis cover must be in place to allow proper airflow and prevent overheating.

### 3.3 Processor and Heatsink Installation

**Warning:** When handling the processor package, avoid placing direct pressure on the label area of the fan.

**Important:**

- For the Processor/Heatsink installation you need to use a T20 screwdriver when opening/closing the CPU socket.
- Always connect the power cord last, and always remove it before adding, removing or changing any hardware components. Make sure that you install the processor into the CPU socket before you install the CPU heatsink.
- If you buy a CPU separately, make sure that you use an AMD-certified heatsink only. Make sure to install the motherboard into the chassis before you install the CPU heatsink.
- When receiving a motherboard without a processor pre-installed, make sure that the plastic CPU socket cap is in place and none of the socket pins are bent; otherwise, contact your retailer immediately.
- When installing the processor and heatsink, ensure a torque driver set to the correct force is used for each screw.
- Refer to the Supermicro website for updates on CPU support.

#### Installing the Processor and Heatsink

1. Unscrew the screws holding down Force Frame in the sequence of 3-2-1. The screws are numbered on the force frame next to each screw hole.

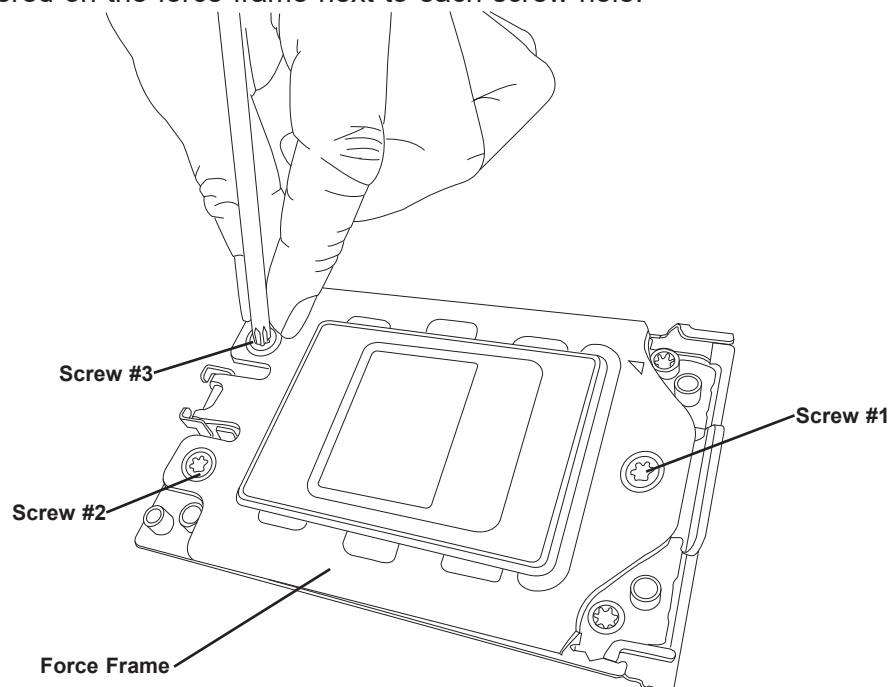

2. The spring-loaded force frame will raise up after the last screw securing it (#1) is removed. Gently allow it to lift up to its stopping position.

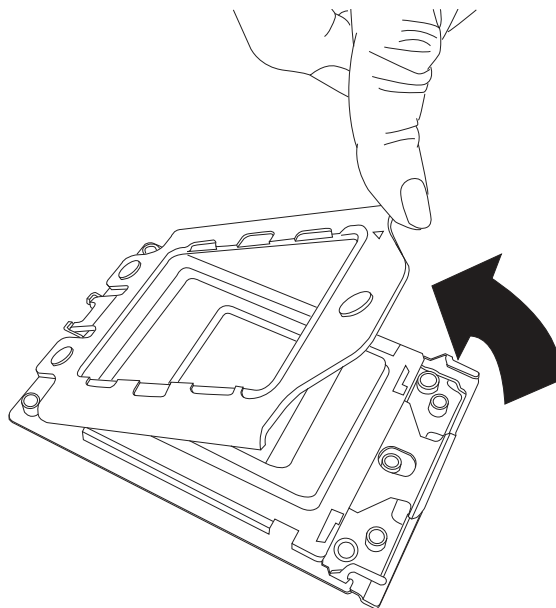

3. Lift the rail frame up by gripping the lift tabs near the front end of the rail frame. While keeping a secure grip of the rail frame, lift it to a position so you can do the next step of removing the external cap.

**Note:** The rail frame is spring loaded, so keep a secure grip on it as you lift it so it does not snap up.

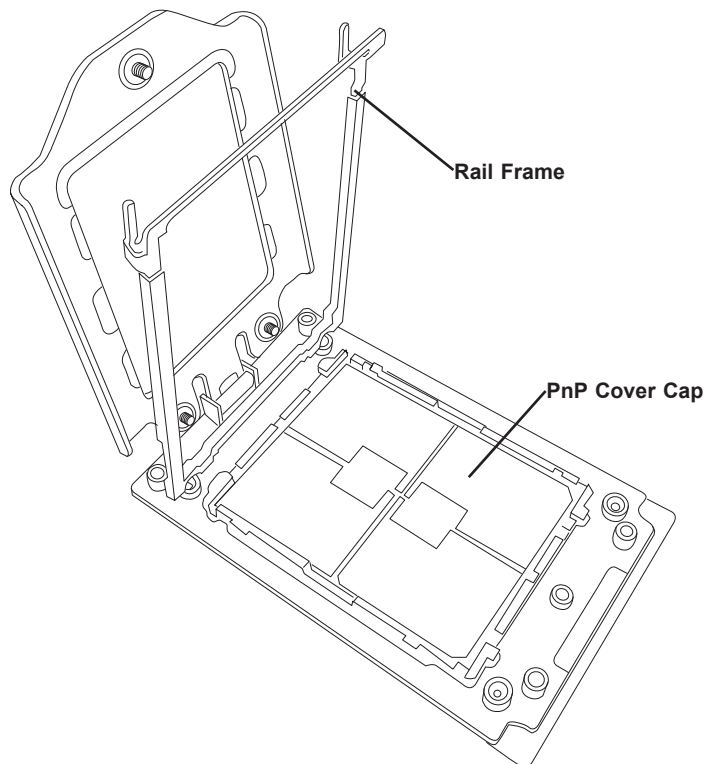

4. Remove the external cap from the Rail Frame by pulling it upwards through the rail guides on the rail frame.

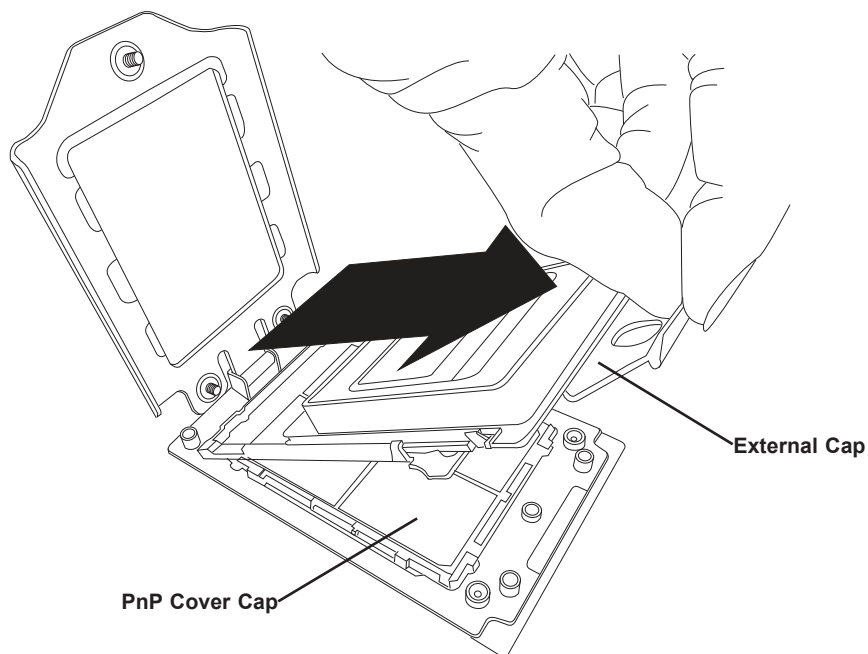

5. The CPU package is shipped from the factory with the blue carrier frame pre-assembled. Grip the handle of the carrier frame/CPU package assembly from its shipping tray, and while gripping the handle, align the flanges of the carrier frame onto the rails of the rail frame so its pins will be at the bottom when the rail frame is lowered later.
6. Slide the carrier frame/CPU package downwards to the bottom of the rail frame. Ensure the flanges are secure on the rails as you lower it downwards.

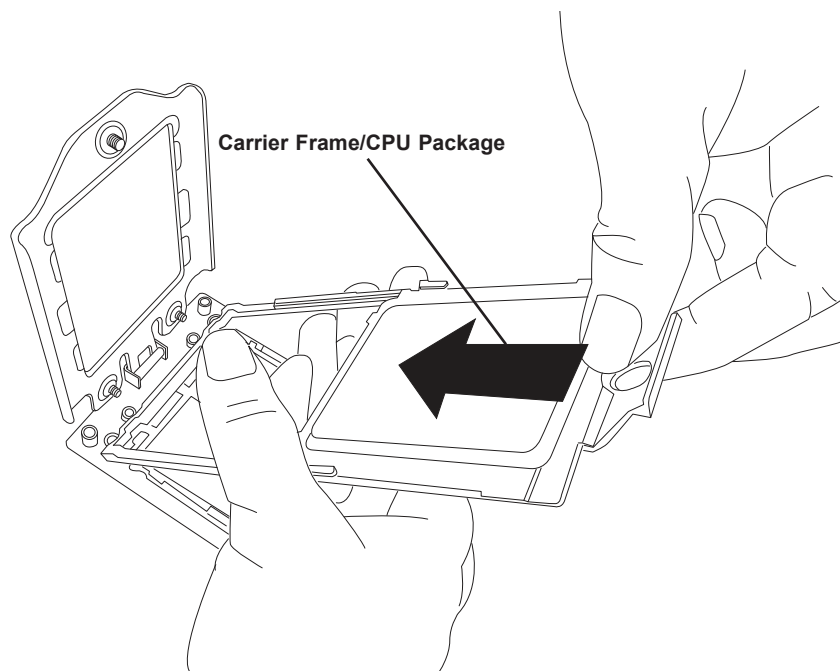

**Note:** You can only install the CPU inside the socket in one direction with the handle at the top. Make sure that it is properly inserted into the CPU socket before closing the rail frame plate. If it doesn't close properly, do not force it as it may damage your CPU. Instead, open the rail frame plate again, and double-check that the CPU is aligned properly.

7. Lift up the rail frame till it securely rests in upright position. Then remove the PnP cover cap from the CPU socket below. Grip the two lift tabs marked "Remove" at the middle of the cap and pull vertically upwards to remove the PnP cover cap.

**Warning!** The exposed socket contacts are extremely vulnerable and can be damaged easily. Do not touch or drop objects onto the contacts and be careful removing the PnP cover cap and when placing the rail frame over the socket.

8. Gently lower the rail frame down onto the socket until the latches on the rail frame engage with the socket housing and it rests in place. **DO NOT** force it into place!

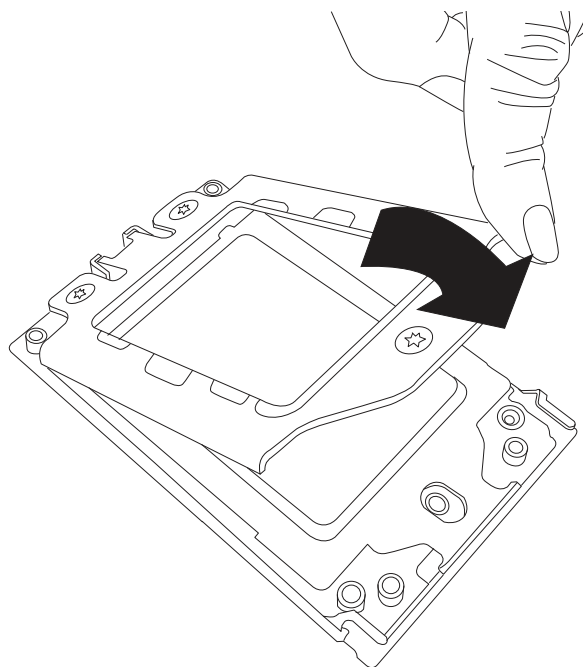

9. Gently lower the force frame down onto the rail frame and hold it in place until it is seated in the Socket housing. Note that the force frame is spring loaded and has to be held in place before it is secured. **Important:** Use a torque screwdriver, set it at 12.5 to 15.0 kgf-cm (10.8 to 13.0 in-lbf) with a Torx T20 screw head bit, to prevent damage to the CPU.

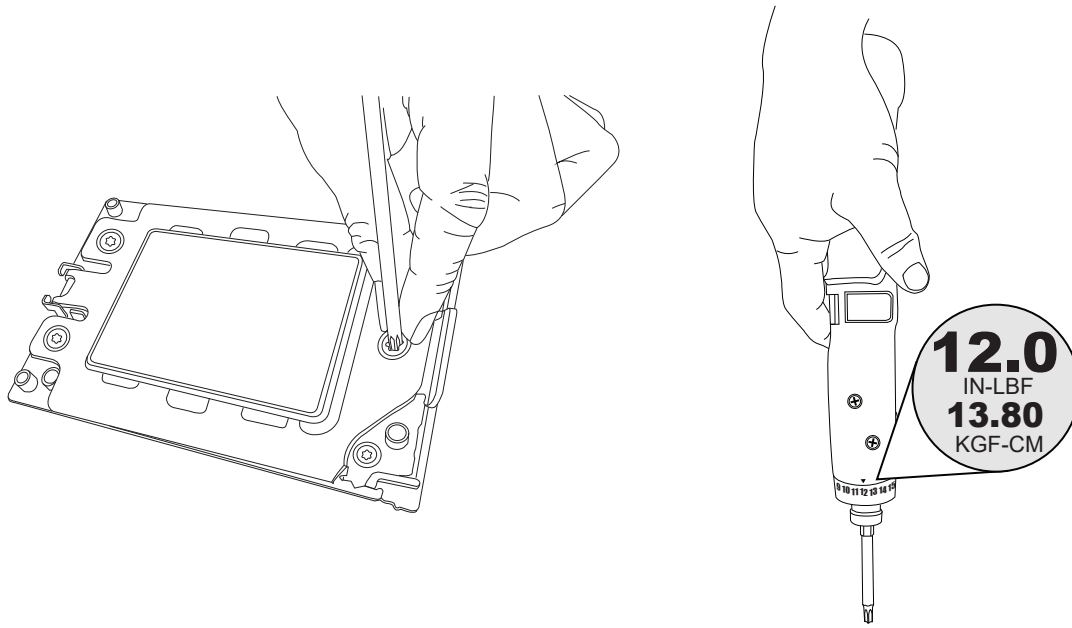

10. Place and re-screw the screws in the reverse order to the way you removed them (holes 1-2-3 in order). When finished, the force frame will be secure over both the rail frame and CPU package.

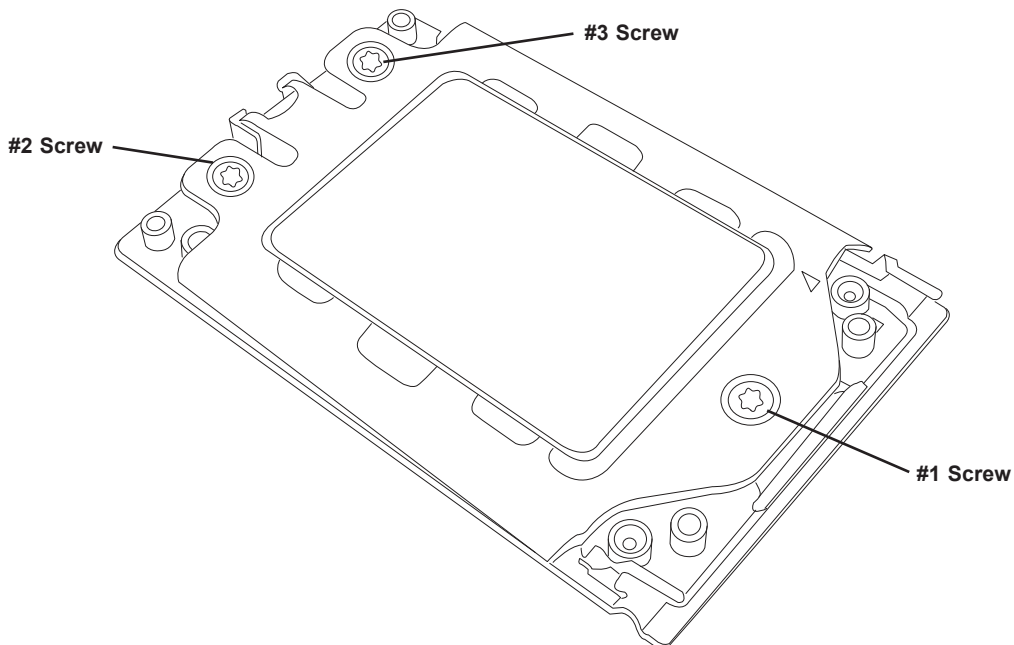

11. After the force frame is secured and the CPU package is in place, now you must install the heatsink to the frame. Lower the heatsink down till it rests securely over the four screw holes on CPU package on the socket frame.

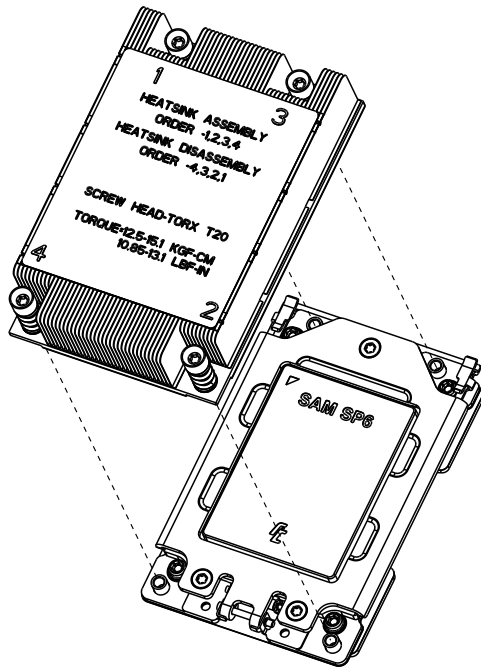

12. Secure the heatsink by tightening the four screws diagonally using a torque screwdriver set to 12.5 to 15.0 kgf-cm (10.8 to 13.0 in-lbf) in a clockwise direction until it is firmly in place. Your processor and heatsink are now installed on the motherboard. Repeat this procedure for any remaining CPU sockets on the motherboard.

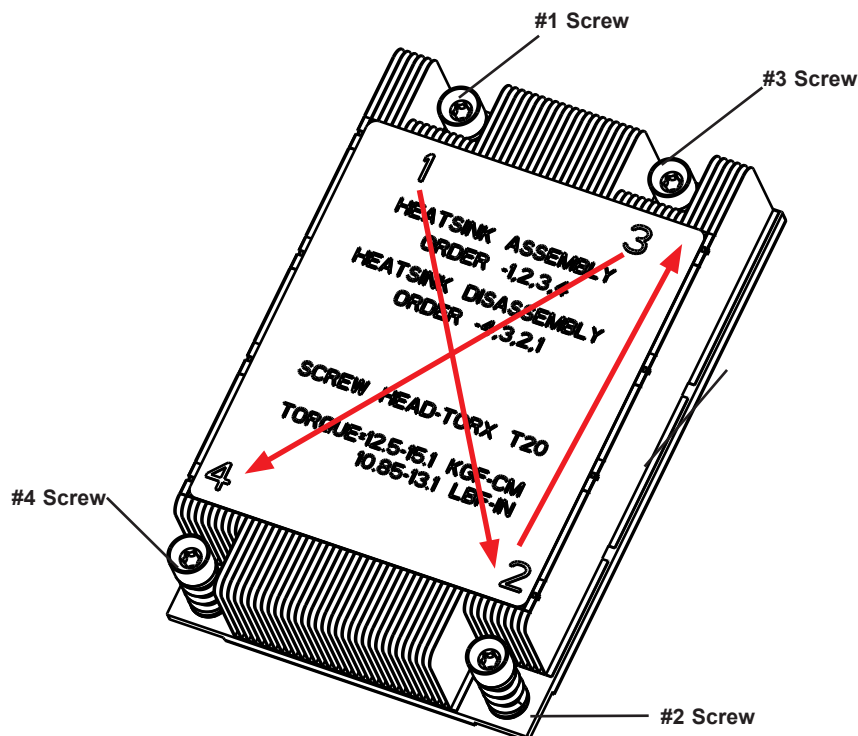

### **Uninstalling the Processor and Heatsink**

1. Remove the heatsink attached to the top of the CPU package by reversing the installation procedure.
2. Clean the Thermal grease left by the heatsink on the CPU package lid to limit the risk of it contaminating the CPU package land pads or contacts in the socket housing.
3. Reverse the procedure for installing the force frame onto the socket, unscrewing the plate in the 3-2-1 screw order and lift the force frame to the vertical position.
4. Lift the rail frame using the lift tabs near the front end of the rail frame. Note that the rail frame is spring loaded, so be careful lifting it up into a vertical position.
5. Grip the handle of the carrier frame and pull upwards to extract it from the rail frame. Return the carrier frame/CPU package to its original shipping container.
6. Grip the handle on the external cap and return it to the rail frame sliding it downwards till it rests in the frame.
7. Gripping the rail frame, rotate it downwards till it rests above and locks over the socket housing in its horizontal position.
8. Push and rotate down the force frame till it is over the external cap and rail frame into a horizontal position.
9. While holding down the force frame, secure it back to the socket frame by securing screw 1 in place. Note that without a CPU package in place, it is not necessary to tighten down screws 2 and 3 at this time.

## 3.4 Memory Support and Installation

**Note:** Check the Supermicro website for recommended memory modules.

**Important:** Exercise extreme care when installing or removing DIMM modules to prevent any possible damage.

### Memory Support

The H13SVW-NT supports up to 576 GB of ECC DDR5 4800 MT/s speed, RDIMM memory in six slots. Refer to the table below for additional memory information.

Populating RDIMM DDR5 Memory Modules with 8004 Processors				
Type	DIMM Population	Maximum DIMM Capacity (GB)		Maximum Frequency (MHz)
	DIMM1	1 Channel	6 Channels	
RDIMM	1Rx8	16GB	96GB	4800
	1Rx4	32GB	192GB	4800
	2Rx4	64GB	384GB	4800
	2Rx4	96GB	576GB	4800

## DIMM Module Population

When populating the motherboard with DIMM modules, please keep in mind the following:

- Always use DDR5 DIMM modules of the same type, size and speed.
- All six memory channels should be populated with each channel having equal capacity, which should provide the best performance in most cases.
- In most configurations, populating fewer than six channels is supported, but not recommended.

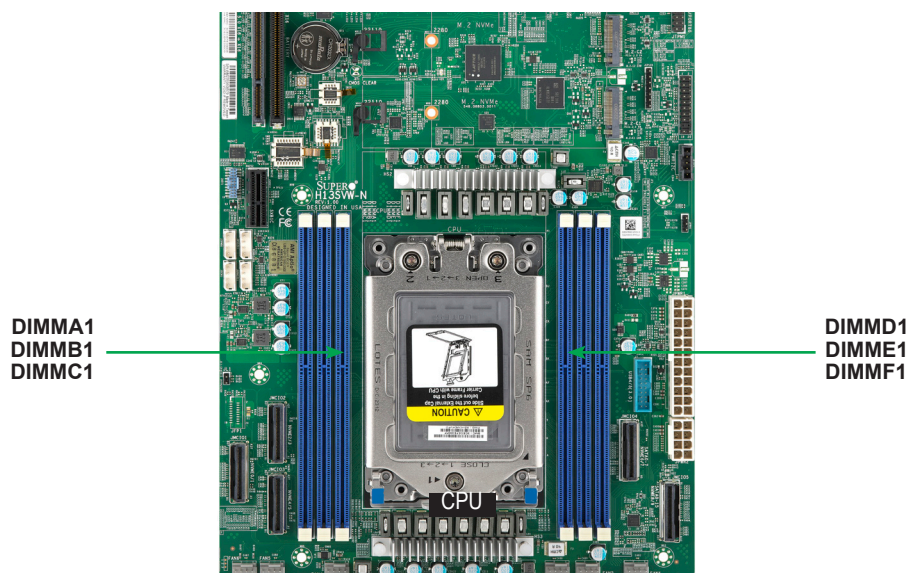

Figure 3-2. DIMM Numbering

Recommended Memory Channels						Node per Socket (NPS)
Channel						
C1	B1	A1	D1	E1	F1	
		1 Channel				NPS1
		✓				NPS2, NPS1
		2 Channels				
		✓	✓			NPS4, NPS2, NPS1
		4 Channels				
✓		✓	✓		✓	NPS2, NPS1
		6 Channels				
✓	✓	✓	✓	✓	✓	NPS2, NPS1

**Note:** For optimal performance, it is recommended to fully populate with six DIMMs.

## DIMM Installation

1. Insert the desired number of DIMMs into the memory slots, starting from DIMMA1. Refer to the [DIMM Module Population](#) section.
2. Push the release tabs outwards on both ends of the DIMM slot to unlock it.
3. Align the key of the DIMM module with the receptive point on the memory slot.
4. Align the notches on both ends of the module against the receptive points on the ends of the slot.
5. Press both ends of the module straight down into the slot until the module snaps into place.
6. Press the release tabs to the lock positions to secure the DIMM module into the slot.

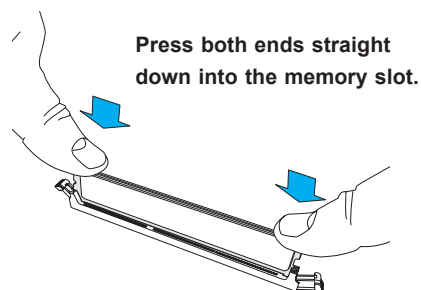
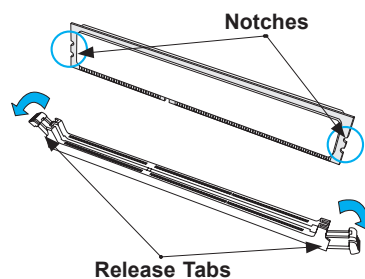
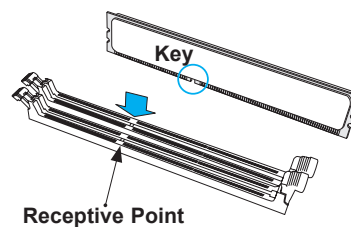

## DIMM Removal

Press both release tabs on the ends of the DIMM module to unlock it. Once the DIMM module is loosened, remove it from the memory slot.

## 3.5 Motherboard Battery

The motherboard uses non-volatile memory to retain system information when system power is removed. This memory is powered by a lithium battery residing on the motherboard.

### **Replacing the Battery**

1. Begin by [removing power](#) from the system.
2. Remove the [chassis top cover](#) and the [air shroud](#).
3. Push aside the small clamp that covers the edge of the battery. When the battery is released, lift it out of the holder.
4. To insert a new battery, slide one edge under the lip of the holder with the positive (+) side facing up. Then push the other side down until the clamp snaps over it.

**Note:** Handle used batteries carefully. Do not damage the battery in any way; a damaged battery may release hazardous materials into the environment. Do not discard a used battery in the garbage or a public landfill. Please comply with the regulations set up by your local hazardous waste management agency to dispose of your used battery properly.

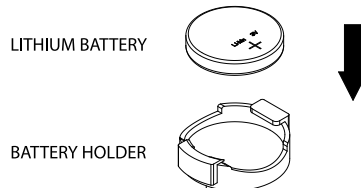

**Figure 3-3. Installing the Onboard Battery**

**Warning:** There is a danger of explosion if the onboard battery is installed upside down (which reverses its polarities). This battery must be replaced only with the same or an equivalent type recommended by the manufacturer (CR2032).

## 3.6 Storage Drives

The system supports four hot-swap 3.5" hybrid storage drive bays. The drives are mounted in drive carriers that simplify their removal from the chassis. These carriers also help promote proper airflow.

**Note:** Enterprise level drives are recommended for use in Supermicro servers. For compatible drives, see the [H13SVW-NT motherboard page](#).

### Installing Drives

#### *Removing a Hot-Swap Drive Carrier from the Chassis*

1. Push the release button on the drive carrier, which will extend the drive bay handle.
2. Use the drive bay handle to pull the drive carrier out of the chassis.



**Figure 3-4. Logical Drive Numbers**

#### *Removing a Hot-Swap Drive Carrirer from the Chassis*

1. Push the release button on the drive carrier, which will extend the drive bay handle.
2. Use the drive bay handle to pull the drive carrier out of the chassis.

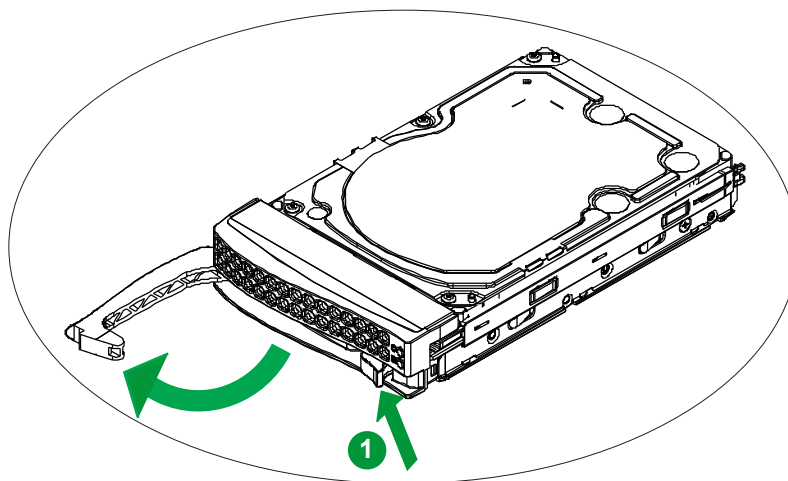

**Figure 3-5. Removing a Drive Carrier**

**Note:** Except for short periods of time while swapping storage drives, do not operate the chassis without the drive carriers.

### Installing a Drive

To install a drive into the chassis, first remove the drive carrier from the chassis.

1. Press the release tab to release the drive carrier from its locking position.
2. Pull the drive carrier out from the chassis as shown below:

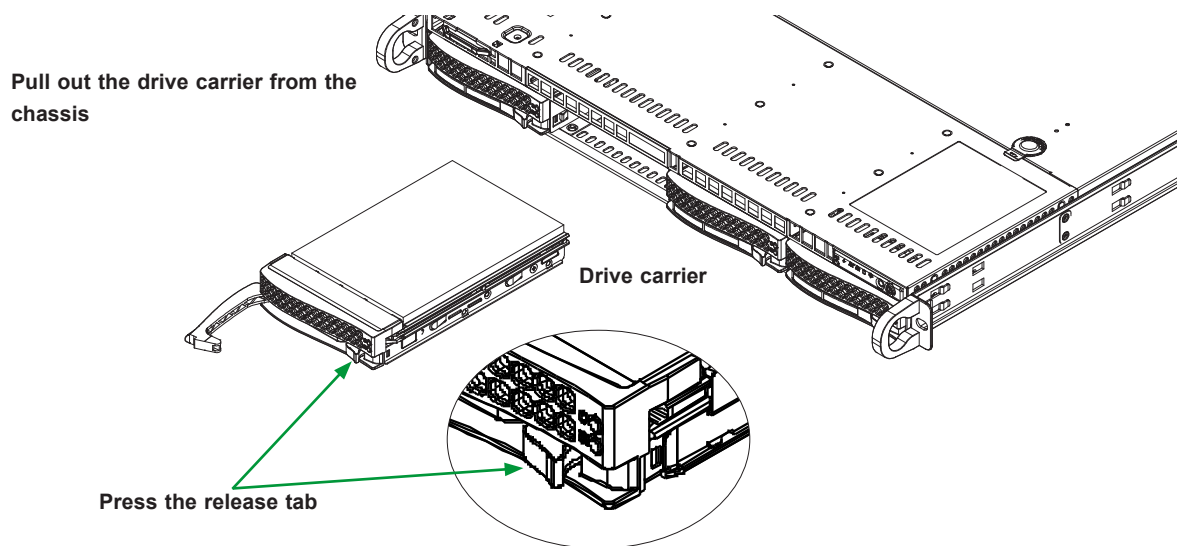

Figure 3-6. Removing Front Drive

3. Remove the dummy tray insert by first removing two screws, then pull out the dummy tray as shown in the illustration below.

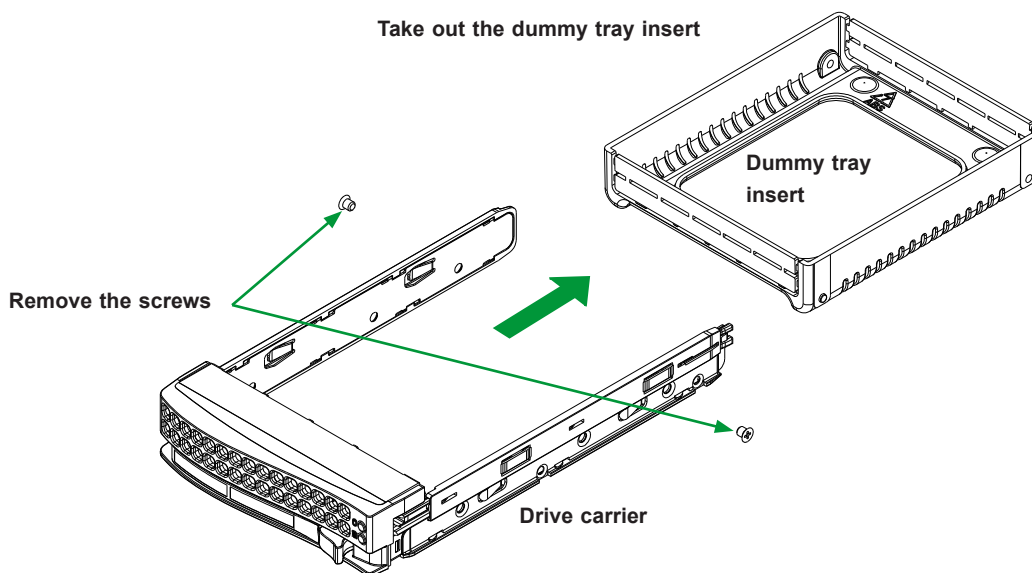
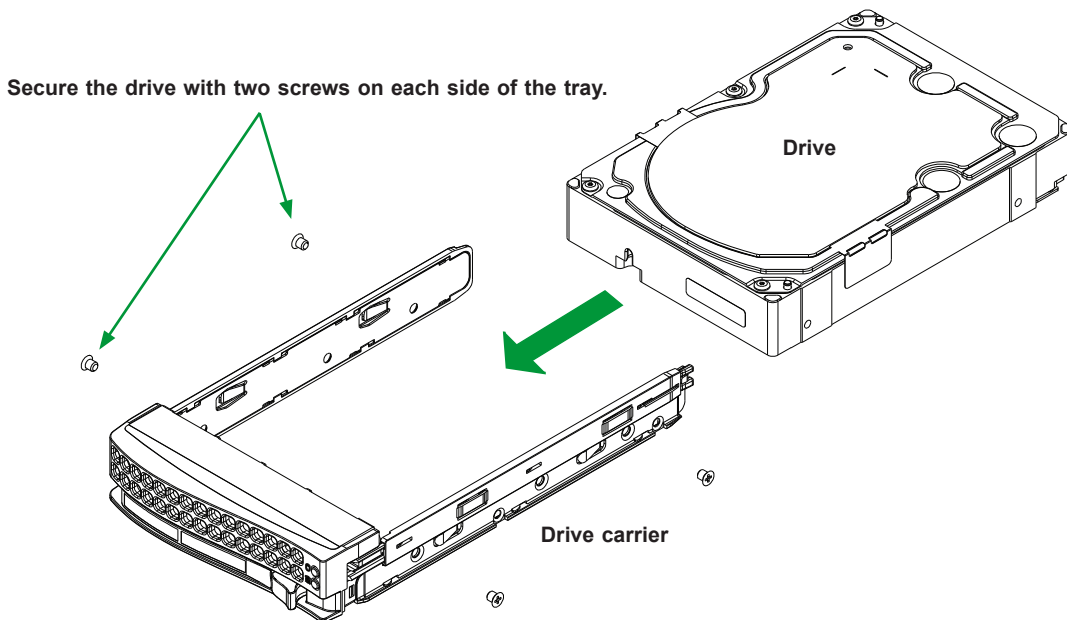

Figure 3-7. Removing Dummy Tray

- Slide a storage drive into the drive carrier, and secure the storage drive to the drive carrier with two screws on each side of the carrier as shown below.



**Figure 3-8. Installing a Drive into Drive Carrier**

- Once the storage drive is securely placed into the drive carrier, you may install the drive carrier with the storage drive back to the chassis.

## Installing M.2 Solid State Drives

The motherboard accommodates two M.2 solid state drive (SSD). The M.2 socket supports NVMe PCIe 3.0 x4 in 2280 or 22110 form factors. The 22110 form factor is recommended because the appropriate standoff comes pre-installed on the motherboard.

### To Install M.2 SSDs

Caution: Use industry-standard anti-static equipment, such as gloves or wrist strap, and follow precautions to avoid damage caused by ESD.

1. Power down the system as described in Section 3.1 and then remove the top chassis cover as described in Section 3.2.
2. Locate M.2 slots on Motherboard at M.2-C1/ M.2-C2.
3. To loosen the M.2 plastic standoff on the motherboard, lift up its top square latch, and use gentle force to pull it out of the hole.
4. Move and place the standoff plug in the proper hole.
5. Insert M.2 device at a slight angle in the M.2 slot, and ensure the notch on the other end of the device aligns the standoff top.
6. Pull the top square latch down and ensure the latch plug is pushed in standoff to secure the device in place.

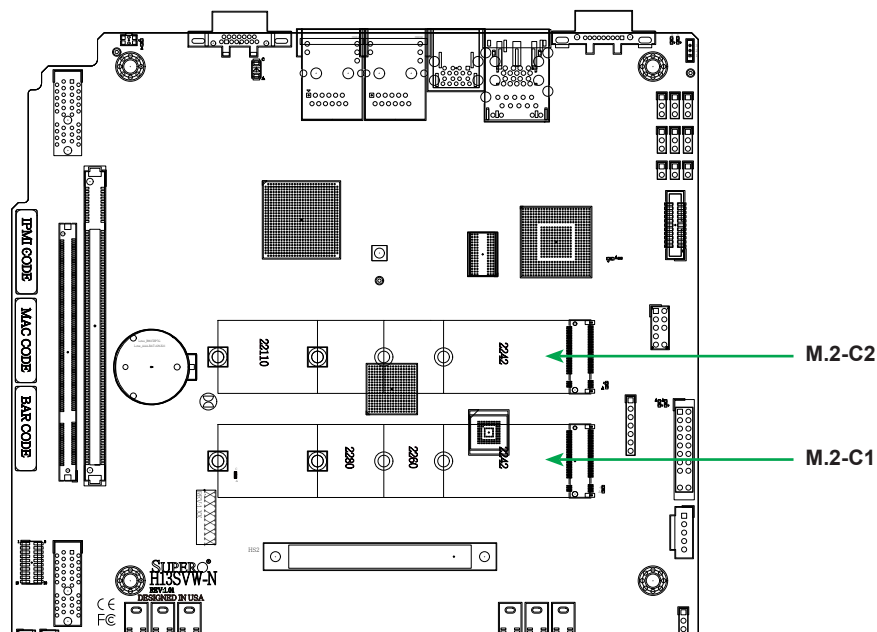

Figure 3-9. M.2 SSD Location

## 3.7 System Cooling

### Fans

Six 4-cm counter-rotating fans provide the cooling for the system. Each fan unit is actually made up of two fans joined back-to-back, which rotate in opposite directions. This counter-rotating action generates exceptional airflow and works to dampen vibration levels.

Make sure the chassis top cover makes a good seal so air circulates properly through the chassis.

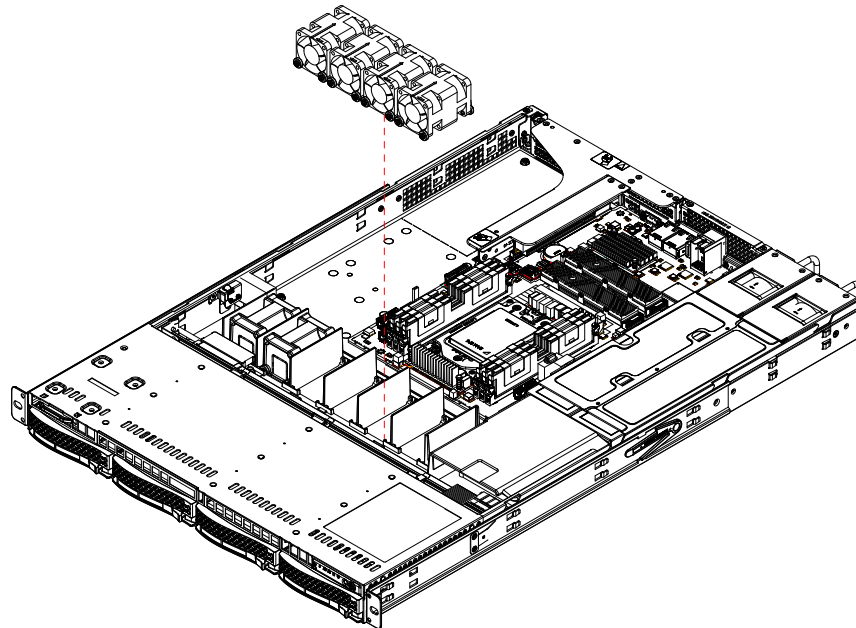

Figure 3-10. Fan Positions

### Changing a System Fan

1. Determine which fan is failing. If possible, use the Baseboard Management Controller (BMC), see your motherboard manual. Remove the chassis cover to examine the fans.
2. Power down the system and remove both cords from both power supplies. Remove the chassis from the rack and seat it on a work bench (safety area). Then open the chassis cover as described in section [3.2](#).
3. Remove the power cable of the failed fan from the motherboard.
4. Hold down fan housing with one hand and use the other to lift up the failed fan from the housing and out of the chassis.
5. Place the replacement fan into the vacant space in the housing while checking proper orientation. Ensure the mounting pins are secured in the housing.
6. Connect the fan power cable to the motherboard.
7. Confirm the fans are working properly before closing the chassis cover.

## Installing or Removing Air Shroud

The air shroud directs airflow to maximize cooling efficiency and comes pre-installed with the system. In the rare event that the air shroud needs to be removed or installed follow the procedure below.

### *Installing or Removing Air Shroud*

1. [Remove power](#) from the system.
2. Remove the [chassis cover](#).
3. To install the air shroud, place the air shroud in the chassis. To remove the air shroud, lift the air shroud out of the chassis.

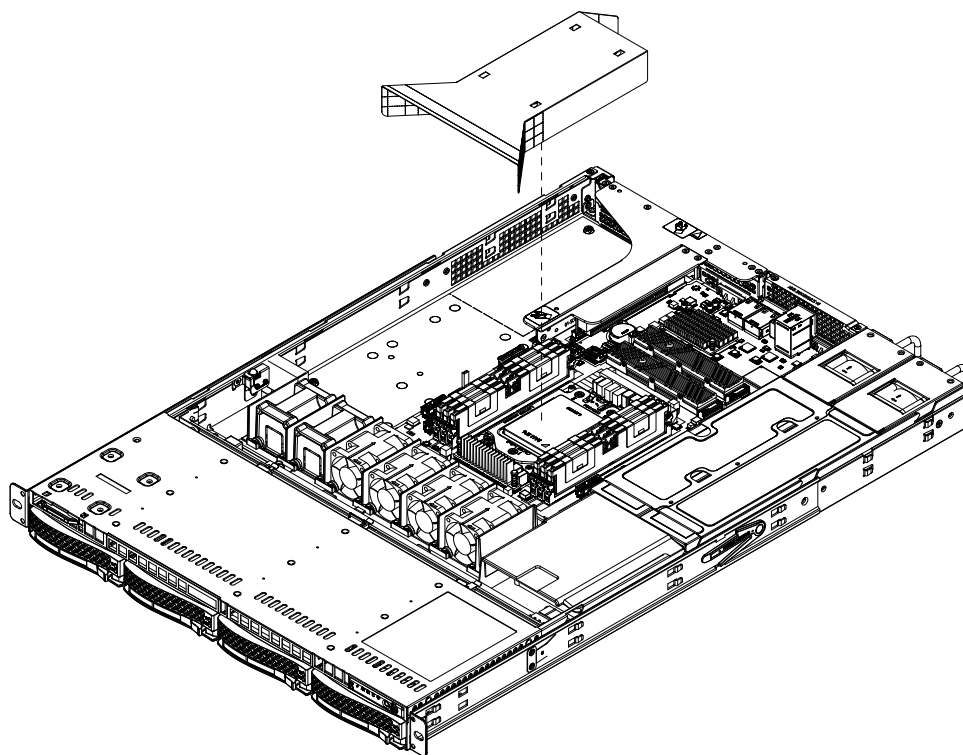

Figure 3-11. Installing or Removing Air Shroud

## 3.8 Power

### Redundant Power Supply System

The chassis features redundant power supplies. The system will continue to operate if one module fails. It should be replaced as soon as convenient. The power supply modules are hot-swappable, meaning they can be changed without powering down the system. New units can be ordered directly from Supermicro or authorized distributors.

These power supplies are auto-switching capable. This feature enables them to automatically sense the input voltage and operate at a 100-127 Vac or 200-240 Vac, 50-60 Hz

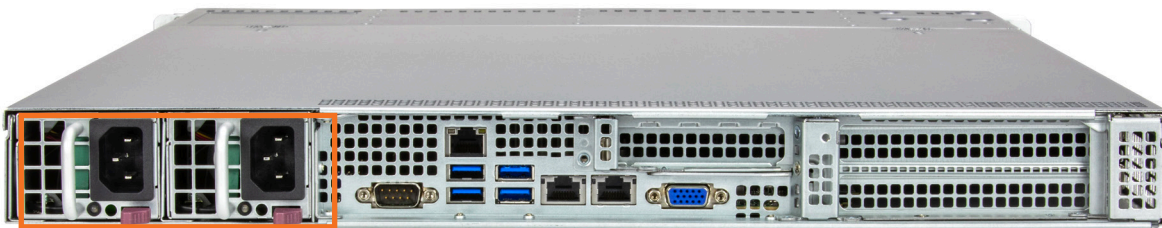

Figure 3-12. Power Supply Location

### Power Supply LEDs

On the rear of the power supply module, an LED displays the status.

- **Solid Green:** When illuminated, indicates that the power supply is on.
- **Blinking Green:** When blinking, indicates that the power supply is plugged in and turned off by the system.
- **Blinking Amber:** When blinking, indicates that the power supply has a warning condition and continues to operate.
- **Solid Amber:** When illuminated, indicates that the power supply is plugged in, and is in an abnormal state. The system might need service. Please contact Supermicro technical support.

## Power Supply Module

### *Changing the SC815B Power Supply Module*

1. The SC815B chassis features two redundant power supply modules. Unless you are replacing both modules, there is no need to power down and/or open the chassis.
2. Press the release tab on the failed power supply.
3. Use the handle to gently slide the power supply out the back of the chassis.
4. Push the new power supply module into the power bay until it clicks into the locked position. Replace with the same model.

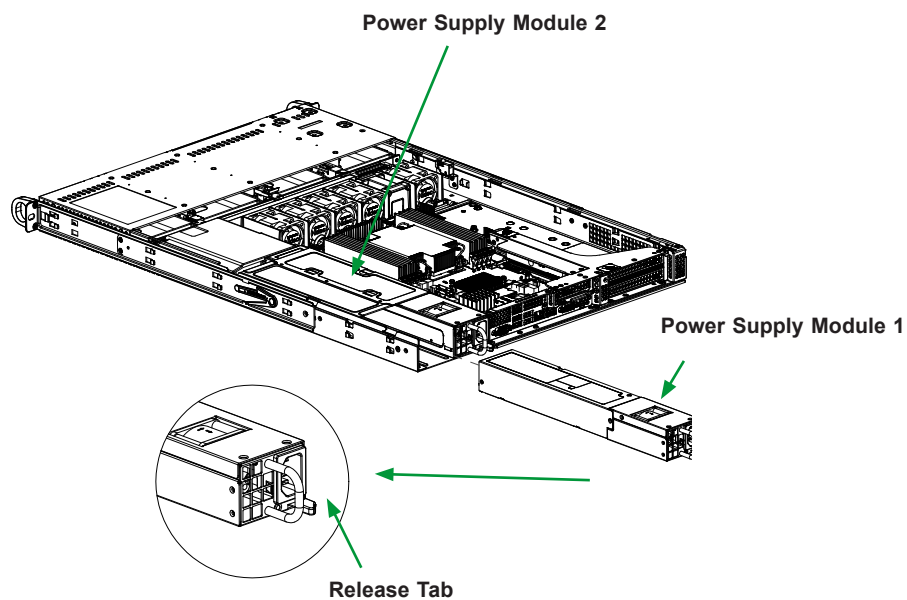

**Figure 3-13. Replacing the SC815B Power Supply**

## 3.9 PCIe Expansion Cards

The system accepts one low-profile and two full-height full-length expansion cards, mounted on riser cards and brackets.

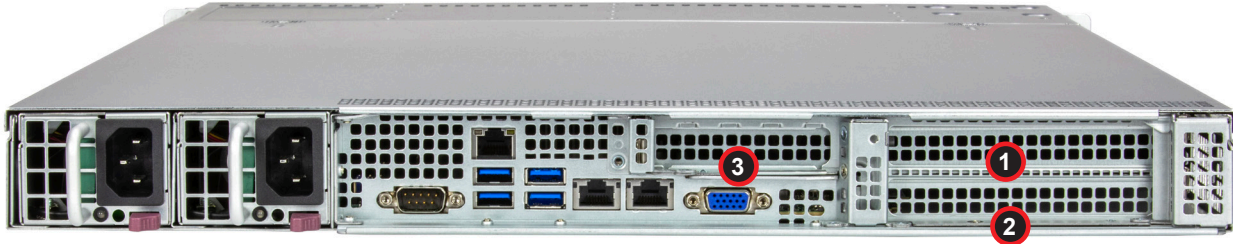

Figure 3-14. Expansion Card Slots in the Chassis

Expansion Slot Locations	
Item	Description
1	One PCIe 5.0 x16 full-height full-length slot for a PCIe expansion card
2	One PCIe 5.0 x16 full-height full-length slot for a PCIe expansion card
3	One PCIe 5.0 x16 low-profile slot for a PCIe expansion card

### Installing an Expansion Card

1. Power down the system as described in section 3.1. Remove the chassis from the rack and seat it on a work bench (safety area). Then open the chassis cover as described in section 3.2.
2. Slightly pull the riser bracket up from the CPU side first, then vertically pull up the riser bracket by applying even pressure to both ends. (Please refer to Figure 3-16.)
3. Install the add-on expansion cards into their slots on the riser cards, in the riser bracket. Screws are not necessary.
4. Insert the expansion card into slot(s) on the riser card while aligning the expansion card backplate with the open slot in the rear of the chassis. Flip the small metal lever to secure the add-on card.

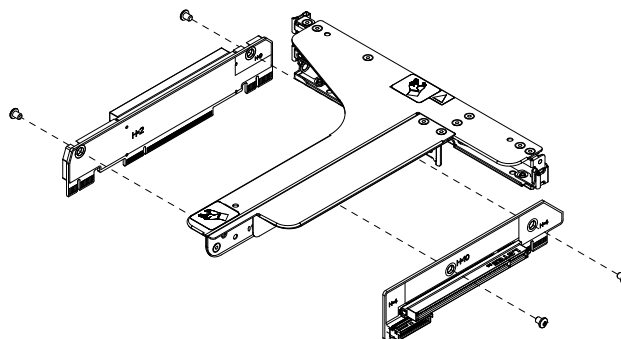

Figure 3-15. Top Load Riser Bracket

5. Connect cables to the expansion card as necessary.
6. Replace the chassis cover, plug the power cords into the rear of the power supply modules and power up the system.

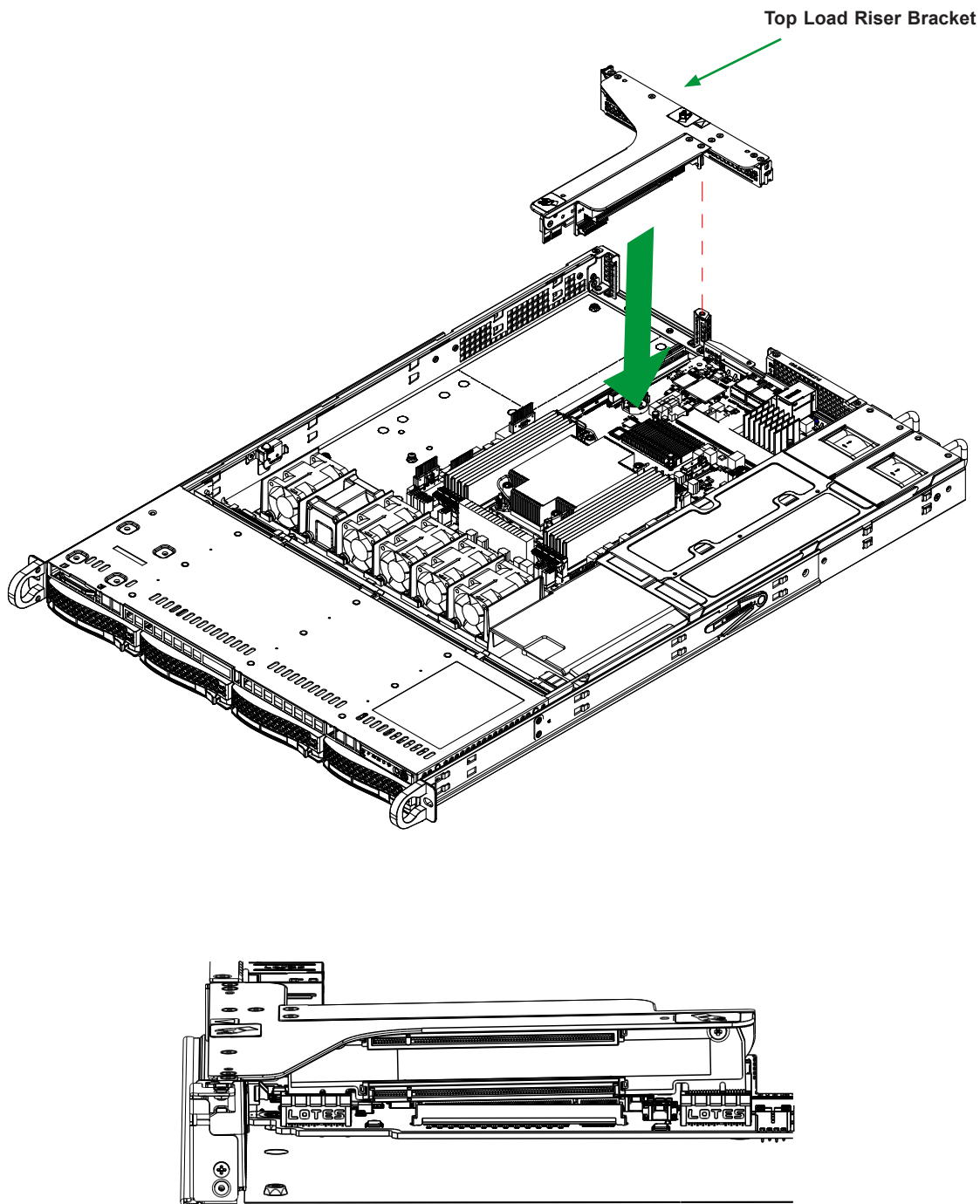
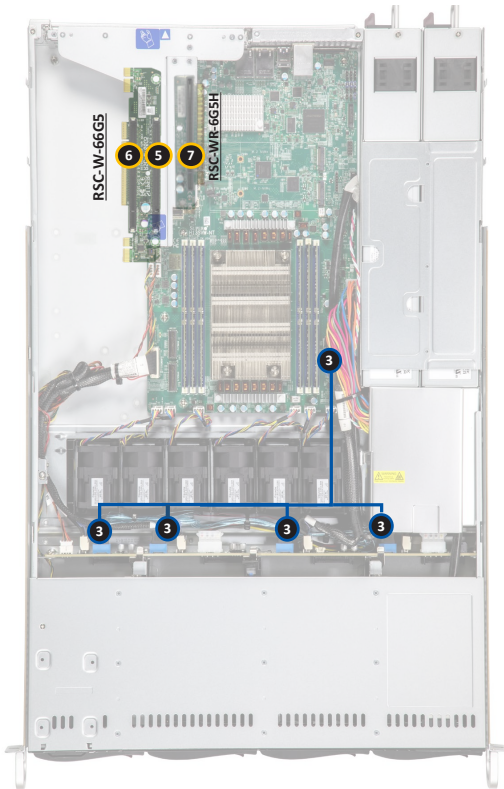

Figure 3-16. Installing the Riser Card

## 3.10 Cable Routing Diagram

Use this section to route or reroute cables. Proper routing is important to maintain airflow through the system.

### 4x SATA (Default)



#### Storage Cables

	Cable	Description	BPN Port	MB Port
3	CBL-MCIO-12700T4S2-85	SATA 0-3	SATA/SAS# 0,1,2,3	JMCIO4

#### Rear PCIe Cable



	Cable	Description	Riser Port	MB Port
5	NA	RSC-W-66G5 (Slot 1)	Gold Finger	SXB1
6	NA	RSC-W-66G5 (Slot 2)	Gold Finger	
7	NA	RSC-WR-6G5H (Slot 3)	Gold Finger	SXB2

## 4x SATA/NVMe Hybrid

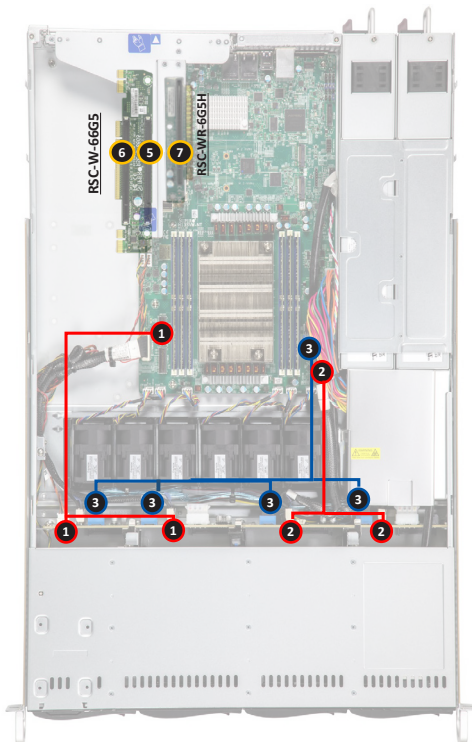

### Storage Cables

	Cable	Description	BPN Port	MB Port
1	CBL-MCIO-1235M5Y	NVMe 0-1	NVME#0,1	JMCIO1
2	CBL-MCIO-1225M5Y	NVMe 2-3	NVME#2,3	JMCIO5
3	CBL-MCIO-1270OT4S2-85	SATA 0-3	SATA/SAS# 0,1,2,3	JMCIO4

### Rear PCIe Cable



	Cable	Description	Riser Port	MB Port
5	NA	RSC-W-66G5 (Slot 1)	Gold Finger	SXB1
6	NA	RSC-W-66G5 (Slot 2)	Gold Finger	
7	NA	RSC-WR-6G5H (Slot 3)	Gold Finger	SXB2

## 4x SATA/SAS via AOC 3808/3908

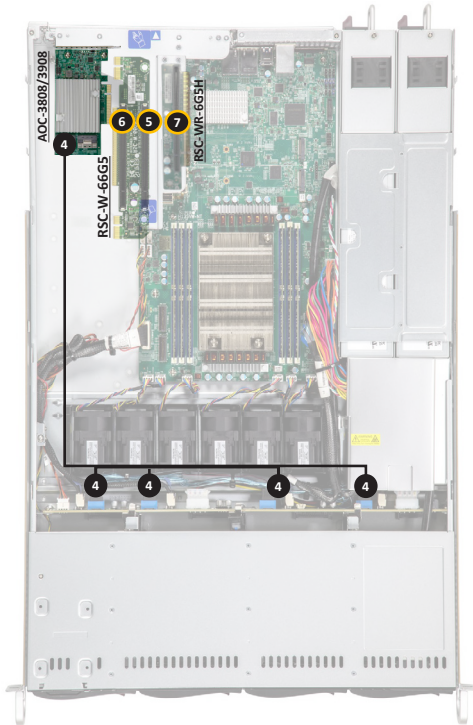

### Storage Cables

	Cable	Description	BPN	MB/AOC Port
4	CBL-SAST-1275A-100	SAS 0-3	SATA/SAS# 0,1,2,3	AOC CN1

### Rear PCIe Cable

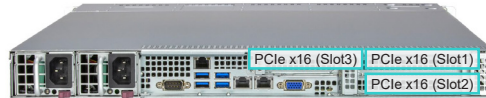

	Cable	Description	Riser Port	MB Port
5	NA	RSC-W-66G5 (Slot 1)	Gold Finger	SXB1
6	NA	RSC-W-66G5 (Slot 2)	Gold Finger	
7	NA	RSC-WR-6G5H (Slot 3)	Gold Finger	SXB2

## Chapter 4

# Motherboard Connections

This section describes the connections on the motherboard and provides pinout definitions. Note that depending on how the system is configured, not all connections are required. The LEDs on the motherboard are also described here. A motherboard layout indicating component locations may be found in [Chapter 1](#). More detail can be found in the [Motherboard Manual](#). Please review the Safety Precautions in [Appendix A](#) before installing or removing components.

## 4.1 Power Connections

### Power Connections

#### Main Power Supply Connector (JPWR1)

The primary power supply connector (JPWR1) is an ATX power connector that the power supply plugs into directly.

ATX Power 24-pin Connector Pin Definitions			
Pin#	Definition	Pin#	Definition
13	+3.3 V	1	+3.3 V
14	-12 V	2	+3.3 V
15	Ground	3	Ground
16	PS_ON	4	+5 V
17	Ground	5	Ground
18	Ground	6	+5 V
19	Ground	7	Ground
20	Res (NC)	8	PWR_OK
21	+5 V	9	5VSB
22	+5 V	10	+12 V
23	+5 V	11	+12 V
24	Ground	12	+3.3 V

#### 12V 8-pin Auxiliary Power Connector (JPWR2)

JPWR2 is an 8-pin ATX power input to provide auxiliary power to the processor. Refer to the table below for pin definitions.

12V 8-pin Power Connector Pin Definitions	
Pins	Definition
1 through 4	Ground
5 through 8	+12 V

## 4.2 Headers and Connectors

### Onboard Fan Headers (FAN1~FAN6)

There are six fan headers on the motherboard. These are 4-pin fan headers; pins 1-3 are backward compatible with traditional 3-pin fans. The onboard fan speeds are controlled by Thermal Management (via Hardware Monitoring) in the BMC. When using Thermal Management setting, please use all 4-pin fans.

Fan Header Pin Definitions	
Pin#	Definition
1	Ground (Black)
2	+12 V (Red)
3	Tachometer (Yellow)
4	PWM Control (Blue)

### Disk-On-Module Power Connector (JSD1 & JSD2)

The Disk-On-Module (DOM) power connector at JSD1 provides 5 V power to a solid-state DOM storage device connected to one of the SATA ports. See the table below for pin definitions.

DOM Power Pin Definitions	
Pin#	Definition
1	5 V
2	Ground
3	Ground

### SATA (SATA16, SATA17)

The H13SVW-NT has two available SATA 3.0 ports (SATA16 and SATA17). These are standard SATA 3.0 ports.

SATA Connectors Pin Definitions	
Pin#	Definition
1	Ground
2	SATA_TXP
3	SATA_TXN
4	Ground
5	SATA_RXN
6	SATA_RXP
7	Ground

### NVMe Ports (NVMe 0/1)

The H13SVW-NT has three dedicated NVMe ports (two ports on a MCIO connector). These ports provide high-speed, low-latency PCIe 5.0 x4 connections directly from the CPU to NVMe Solid State (SSD) drives. This greatly increases SSD data-throughput performance and significantly reduces PCIe latency by simplifying driver/software requirements resulting from direct PCIe interface from the CPU to the NVMe SSD drives.

### SATA/NVMe Hybrid Ports (SATA 0-7/NVMe 6-7; SATA 8-15/NVMe 8-9)

Each SATA/NVMe hybrid port can support up to eight SATA 3.0 ports or two NVMe ports (PCIe x4), for a total of 16 SATA ports or four NVMe ports.

### SPI TPM

A Trusted Platform Module (TPM)/Port 80 header is located at JTPM1 to provide TPM support and Port 80 connection. Use this header to enhance system performance and data security. Refer to the table below for pin definitions. Please go to the following link for more information on the TPM: <http://www.supermicro.com/manuals/other/TPM.pdf>.

Trusted Platform Module Header Pin Definitions			
Pin#	Definition	Pin#	Definition
1	+3.3 V	2	SPI_CS#
3	RESET#	4	SPI_MISO
5	SPI_CLK	6	GND
7	SPI_MOSI	8	NC
9	+3.3 V Stdby	10	SPI_IRQ#

### PCIe M.2 Connector (M.2-C1, M.2-C2)

The PCIe M.2 connectors are for devices such as memory cards, wireless adapters, etc. These devices must conform to the PCIe M.2 specifications (formerly known as NGFF). These particular PCIe M.2 supports M-Key (PCIe x2) storage cards.

## USB Ports (USB 0~3, USB 4/5)

There are a total of seven USB ports supported on the motherboard. Four are located on the back panel; USB 0/1, and USB 2/3 (both are USB 3.1 compliant). There are also three ports located on the motherboard, two are on one header, USB 4/5 (3.1).

Front Panel USB 3.1 Pin Definitions			
Pin#	Definition	Pin#	Definition
1	VBUS	19	Power
2	USB3_P1_SSRX-	18	USB3_P2_SSRX-
3	USB3_P1_SSRX+	17	USB3_P2_SSRX+
4	GND	16	GND
5	USB3_P1_SSTX-	15	USB3_P2_SSTX-
6	USB3_P1_SSTX+	14	USB3_P2_SSTX+
7	GND	13	GND
8	USB_P1_N	12	USB_P2_N
9	USB_P1_P	11	USB_P2_P
10	GND		

## Expansion Slots

The motherboard features several expansion slots. The table below describes each slot's type and speed.

Expansion Slots	
Name	Description
<b>SXB1A</b>	Riser Slot
<b>SXB1B</b>	Riser Slot (for CPU Slot1 PCIe 5.0 x16, Slot3, PCIe 5.0 x16)
<b>SXB1C</b>	Riser Slot
<b>SXB2</b>	Riser Slot (for CPU Slot2, PCIe 5.0 x16)

## Onboard Battery (BATTERY)

The onboard back up battery is located at BATTERY. The onboard battery provides backup power to the on chip CMOS, which stores the BIOS' setup information. It also provides power to the Real Time Clock (RTC) to keep it running.

## Chassis Intrusion (JL1)

A Chassis Intrusion header is located at JL1 on the motherboard. Attach the appropriate cable from the chassis to the header to inform you when the chassis is opened.

Chassis Intrusion Pin Definitions	
Pins	Definition
1	Ground
2	Intrusion Input

### Overheat LED/Fan Fail (JOH1)

The JOH1 header is used to connect an LED indicator to provide warnings of chassis overheating or fan failure. This LED will blink when a fan failure occurs. Refer to the table below for pin definitions.

Overheat / Fan Fail Pin Definitions	
Pins	Definition
1	5 VDC
2	OH Active

Overheat / Fan Fail LED Status	
Status	Definition
Off	Normal
On, Solid	Overheat
On, Blinking	Fan Failure

### IPMB System Management Bus Header (JIPMB1)

A System Management Bus header for IPMI 2.0 is located at JIPMB1. Connect the appropriate cable here to use the IPMB I<sup>2</sup>C connection on your system.

IPMB Header Pin Definitions	
Pin#	Definition
1	Data
2	Ground
3	Clock
4	+3.3 V Stdby

## 4.3 Input/Output Ports

### Rear I/O Ports

See the figure below for the locations and descriptions of the I/O ports on the rear of the motherboard.

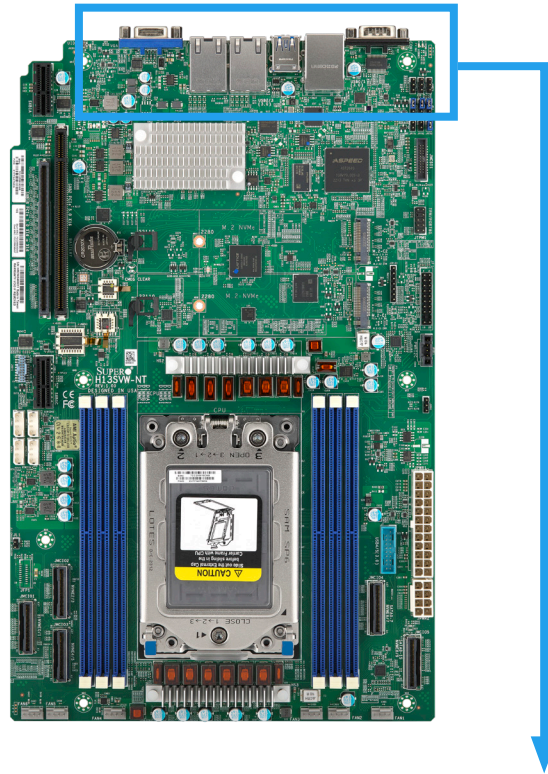
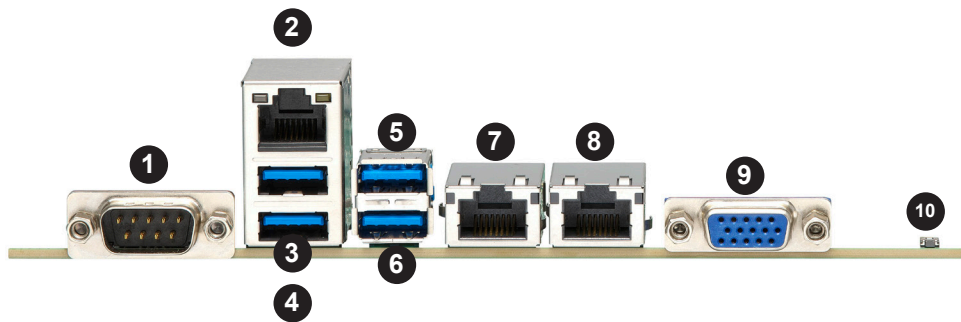

Figure 4-1. I/O Port Locations and Definitions



Rear I/O Ports					
#	Description	#	Description	#	Description
1	COM Port	5	USB 2 (3.0)	9	VGA Port
2	IPMI LAN Port	6	USB 3 (3.0)	10	UID Switch & UID LED
3	USB 0 (3,0)	7	LAN Port #1		
4	USB 1 (3.0)	8	LAN Port #2		

**1. COM Port**

There is one serial communications port (COM1) on the rear I/O panel.

**2. IPMI LAN Port**

One IPMI LAN port is located on the I/O back panel. This port accepts an RJ45 type cable.

**3~6. Universal Serial Bus (USB) Ports**

There are four USB 3.0 ports (USB 0/1, 2/3) on the I/O back panel. These support the type A connector.

**7~8. LAN Ports**

There are two LAN ports located on the I/O back panel (LAN1 & LAN2). These ports accept RJ45 type cables.

**9. VGA Port**

There is one VGA port on the rear I/O panel.

**10. UID Switch and UID LED Indicator**

A Unit Identifier (UID SW) switch and UID LED (LED1) are located on the I/O backpanel. The rear UID LED (LED1) is located next to the UID switch. When you press the UID switch, both rear and front UID LED indicators will turn on. Press the UID switch again to turn off the LED indicators. The UID Indicator provides easy identification of a system that may be in need of service. See [2.6 Front Control Panel](#) for the front panel UID LED header location on JF1.

**Note:** UID can also be triggered via IPMI on the motherboard. For more information on IPMI, please refer to the IPMI User's Guide posted on our website at <http://www.supermicro.com>

## 4.4 Jumper Settings

### How Jumpers Work

To modify the operation of the motherboard, jumpers can be used to choose between optional settings. Jumpers create shorts between two pins to change the function of the connector. Pin #1 is identified with a thicker border line on the printed circuit board. See the diagram below for an example of jumping pins 1 and 2. Refer to the motherboard layout page for jumper locations.

**Note:** On two-pin jumpers, "Closed" means the jumper is on and "Open" means the jumper is off the pins.

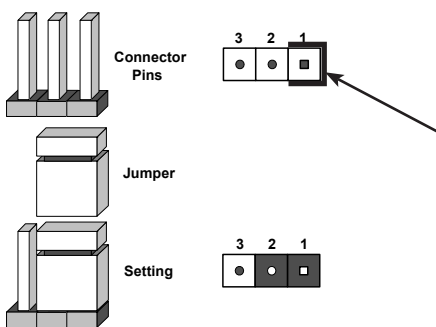

### Clear CMOS (JBT1)

JBT1 is used to clear CMOS, which will also clear any passwords. Instead of pins, this jumper consists of contact pads to prevent accidentally clearing the contents of CMOS.

#### To Clear CMOS

1. First power down the system and unplug the power cord(s).
2. Remove the cover of the chassis to access the motherboard.
3. Remove the onboard battery from the motherboard.
4. Short the CMOS pads with a metal object such as a small screwdriver for at least four seconds.
5. Remove the screwdriver (or shorting device).
6. Replace the cover, reconnect the power cord(s), and power on the system.

**Note:** Clearing CMOS will also clear all passwords.

Do not use the PW\_ON connector to clear CMOS.



**LAN Enable/Disable (JPL1)**

Jumper JPL1 will enable or disable LAN1/LAN2. See below for jumper settings. The default setting is enabled.

<b>GLAN Enable Jumper Settings</b>	
<b>Pin#</b>	<b>Definition</b>
1-2	Enabled (default)
2-3	Disabled

## 4.5 LED Indicators

### Onboard LAN Port LEDs

The motherboard's Ethernet ports have two LED indicators. The Activity LED is green and indicates connection and activity. The Link LED may be green, orange/amber, or off to indicate the speed of the connection. Refer to the tables below for more information.

Link LED, Connection Link, Speed Indicator	
LED Color	Definition
Orange	1 Gb/s
Green	10 Gb/s

Activity LED		
Color	State	Definition
None	No Connection	
None	Off	Link
Green	Flashing	Active

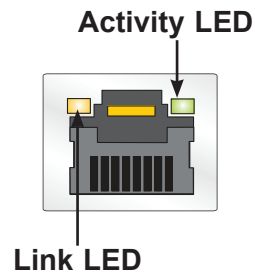

### BMC LAN Port LEDs

A dedicated BMC LAN is located on the rear I/O panel and has two LED indicators. The LED on the right indicates connection and activity, while the LED on the left indicates the speed of connection. The Link LED may be amber, or off to indicate the speed of the connection. Refer to the tables below for more information.

Link LED, Connection Link, Speed Indicator	
LED Color	Definition
Amber	1 Gb/s
Green	100 Mb/s
Off	10 Mb/s

Activity LED		
Color	State	Definition
None	No Connection	
Yellow	Solid On	Link
Yellow	Flashing	Active

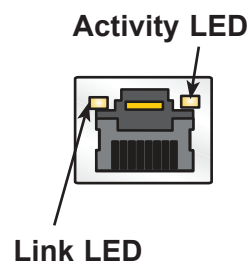

### UID LED Indicator (LED9)

The rear LED9 is located next to the UID switch. The front UID LED is located on the front panel. When you press the UID switch, both rear LED9 and front UID LED indicators will turn on. Press the UID switch again to turn off the LED indicators. Use this UID Indicator to "mark" the system, so the system can be easily identified whether on the front or back (e.g., a system rack with multiple units installed). See also UID LED.

UID LED LED Indicator		
Color	State	Definition
Blue	Solid On	Unit Identified
None	Off	UID Off

### BMC Heartbeat LED (LEDBMC1)

A BMC Heartbeat LED is located at LEDBMC1 on the motherboard. When LEDBMC1 is blinking, the BMC is functioning normally. See the table below for more information.

BMC Heartbeat LED State		
Color	State	Definition
Green	Solid On	BMC is not ready
Green	Blinking	BMC Normal
Green	Fast Blinking	BMC: Initializing

### Onboard Power OK LED (LED8)

LED8 is an onboard power OK LED. When this LED8 is lit, it means the system is turned on and all the system power rails are ready. When the system is turned off or any one of the system power rails fail, this LED will turn off. Turn off the system and unplug the power cable before removing or installing any component(s).

Onboard Power LED Indicator	
LED Color	Definition
Off	System Off (power cable not connected)
Green	System On, Power OK

# Chapter 5

## Software

After the hardware has been installed, you can install the Operating System (OS), configure RAID settings and install the drivers.

### 5.1 Microsoft Windows OS Installation

If you will be using RAID, you must configure RAID settings before installing the Windows OS and the RAID driver. Refer to the RAID Configuration User Guides posted on our website at [www.supermicro.com/support/manuals](http://www.supermicro.com/support/manuals).

#### *Installing the OS*

1. Create a method to access the MS Windows installation ISO file. That might be a USB flash drive or media drive, or the BMC KVM console.
2. Retrieve the proper RST/RSTe driver. Go to the Supermicro web page for your motherboard and click on "Download the Latest Drivers and Utilities", select the proper driver, and copy it to a USB flash drive.
3. Boot from a bootable device with Windows OS installation. You can see a bootable device list by pressing <F11> during the system startup.

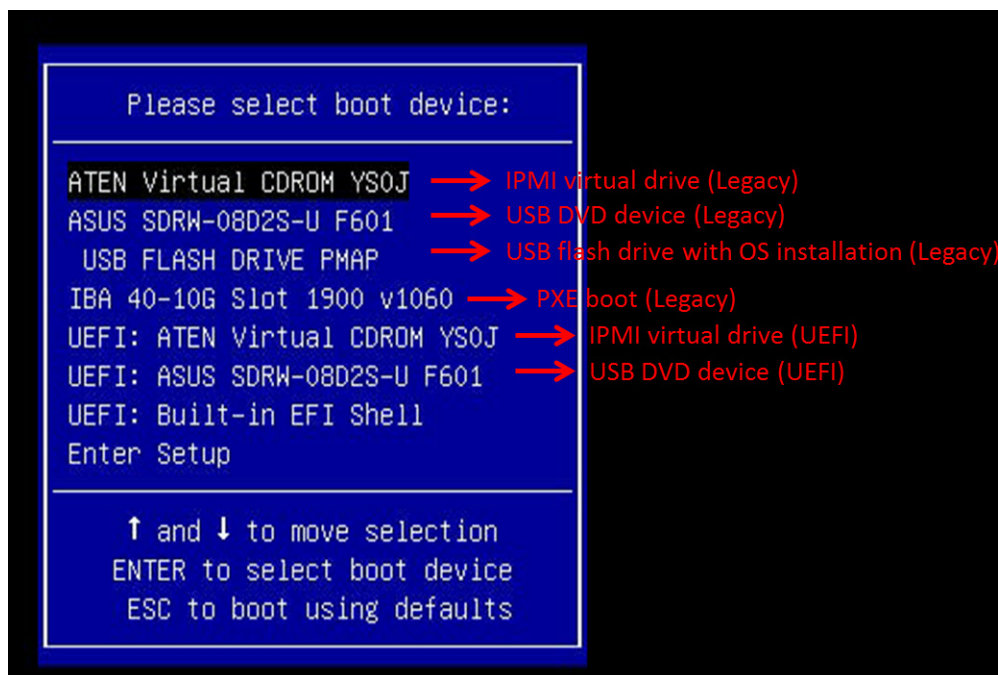
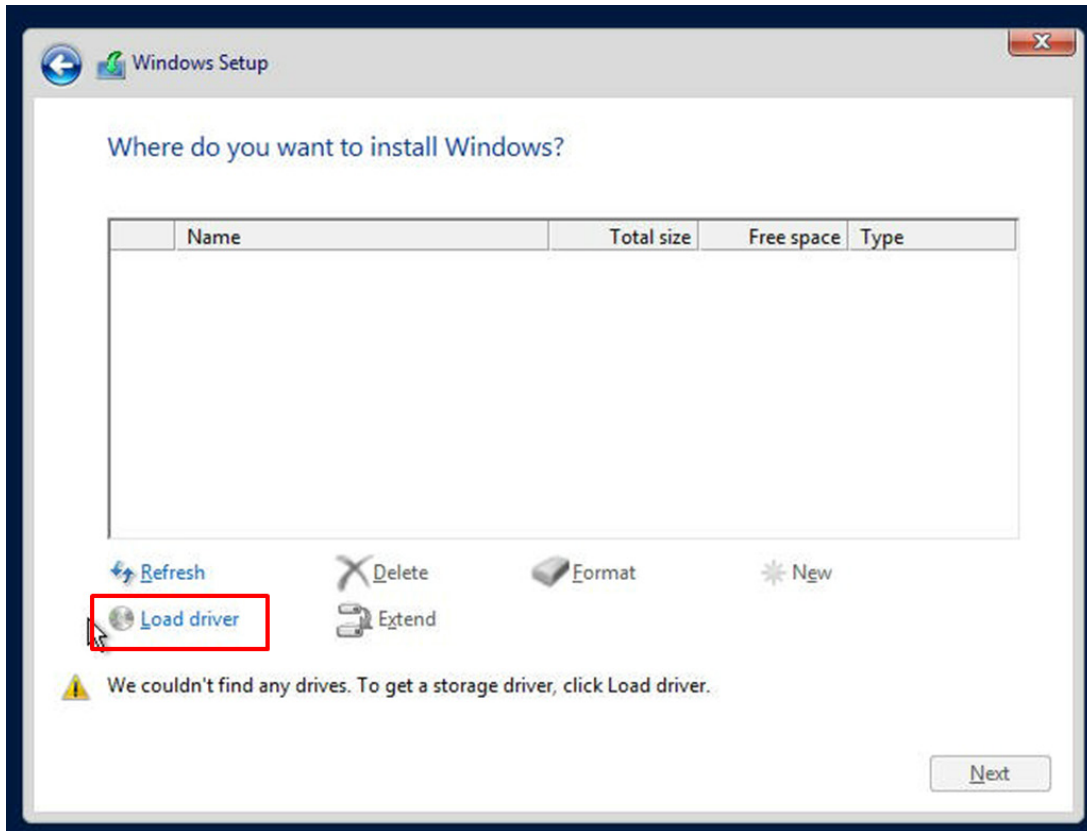

Figure 5-1. Select Boot Device

4. During Windows Setup, continue to the dialog where you select the drives on which to install Windows. If the disk you want to use is not listed, click on “Load driver” link at the bottom left corner.



**Figure 5-2. Load Driver Link**

To load the driver, browse the USB flash drive for the proper driver files.

- For RAID, choose the SATA/sSATA RAID driver indicated then choose the storage drive on which you want to install it.
  - For non-RAID, choose the SATA/sSATA AHCI driver indicated then choose the storage drive on which you want to install it.
5. Once all devices are specified, continue with the installation.
  6. After the Windows OS installation has completed, the system will automatically reboot multiple times.

## 5.2 Driver Installation

The Supermicro website contains drivers and utilities for your system at <https://www.supermicro.com/wdl/driver>. Some of these must be installed, such as the chipset driver.

After accessing the website, go into the CDR\_Images (in the parent directory of the above link) and locate the ISO file for your motherboard. Download this file to a USB flash or media drive. (You may also use a utility to extract the ISO file if preferred.)

Another option is to go to the Supermicro website at <http://www.supermicro.com/products/>. Find the product page for your motherboard, and "Download the Latest Drivers and Utilities".

Insert the flash drive or disk and the screenshot shown below should appear.



Figure 5-3. Driver & Tool Installation Screen

**Note:** Click the icons showing a hand writing on paper to view the readme files for each item. Click the computer icons to the right of these items to install each item (from top to the bottom) one at a time. **After installing each item, you must re-boot the system before moving on to the next item on the list.** The bottom icon with a CD on it allows you to view the entire contents.

## 5.3 SuperDoctor® 5

The Supermicro SuperDoctor 5 is a program that functions in a command-line or web-based interface for Windows and Linux operating systems. The program monitors such system health information as CPU temperature, system voltages, system power consumption, fan speed, and provides alerts via email or Simple Network Management Protocol (SNMP).

SuperDoctor 5 comes in local and remote management versions and can be used with Nagios to maximize your system monitoring needs. With SuperDoctor 5 Management Server (SSM Server), you can remotely control power on/off and reset chassis intrusion for multiple systems with SuperDoctor 5 or BMC. SuperDoctor 5 Management Server monitors HTTP, FTP, and SMTP services to optimize the efficiency of your operation.

### SuperDoctor® Manual and Resources

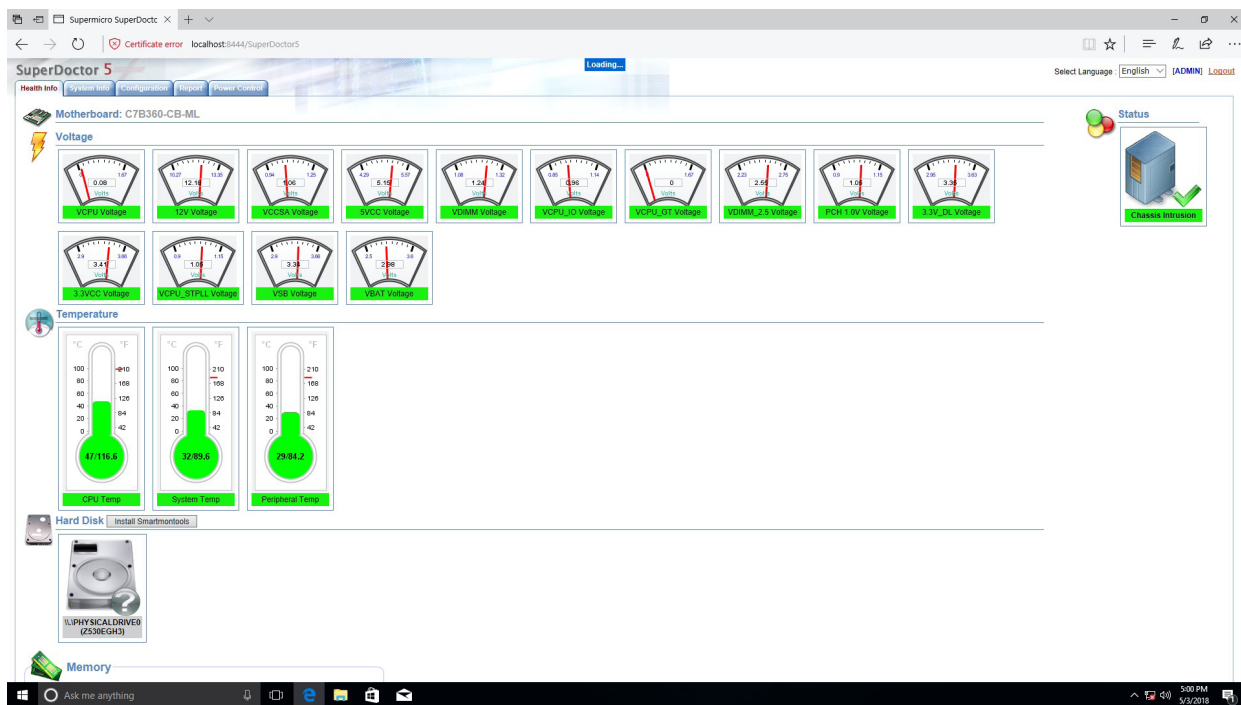

Figure 5-4. SuperDoctor 5 Interface Display Screen (Health Information)

## 5.4 BMC

The motherboard provides remote access, monitoring and management through the baseboard management controller (BMC) and other management controllers distributed among different system modules. There are several BIOS settings that are related to BMC. For general documentation and information on BMC, visit our website at:

[www.supermicro.com/en/solutions/management-software/bmc-resources](http://www.supermicro.com/en/solutions/management-software/bmc-resources)

### BMC ADMIN User Password

For security, each system is assigned a unique default BMC password for the ADMIN user. This can be found on a sticker on the chassis and a sticker on the motherboard. The sticker also displays the BMC MAC address.

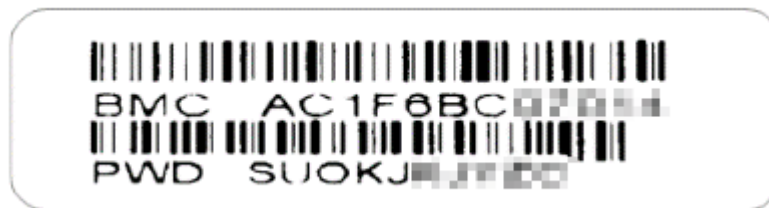

Figure 5-5. BMC Password Label

See [Chapter 1](#) for the label location.

## Chapter 6

# Optional Components

This chapter describes alternate configurations and optional system components.

Optional Parts
Storage drive options
Storage control cards
<a href="#">TPM security module</a>

### 6.1 Storage Drive Options

The storage drive bays can support NVMe, SATA and SAS in any combination. To enable SAS or NVMe, additional hardware is required.

**SATA** – By default, the system can support up to four SATA drives.

**SAS** – The system can support up to four SAS drives from add-on storage controller cards.

\*Additional storage controller cards request

**NVMe** – The system can support up to four NVMe drives.

\*Additional cables are required.

**Note:** Please refer to [Section 6.2](#) for required storage controller, and [Section 3.10](#) for required cables.

### 6.2 Storage Control Cards

Storage Control Card Options	
AOC SKU	Description
AOC-S3908L-H8iR-16DD	SAS RAID Adapter (RAID 0, 1, 5, 6, 10, 50, 60), eight internal SAS3 ports, Supports up to 16 physical devices with expander, One SlimSAS and eight black (100-Ohm) connector
AOC-S3808L-L8iT	SAS Host Bus Adapter (IT mode), eight internal SAS3 ports, Supports up to 122 physical devices with expander, One SlimSAS and eight black (100-Ohm) connectors

## 6.3 TPM Security Module

SPI capable TPM 2.0 with Infineon 9670 controller, vertical form factor

The JTPM1 header is used to connect a Trusted Platform Module (TPM). A TPM is a security device that supports encryption and authentication in hard drives. It enables the motherboard to deny access if the TPM associated with the hard drive is not installed in the system.

Details and installation procedures are at:

<http://www.supermicro.com/manuals/other/TPM.pdf>

- AOM-TPM-9670V

# Chapter 7

## Troubleshooting and Support

### 7.1 Information Resources

#### Website

A great deal of information is available on the Supermicro website, [supermicro.com](http://supermicro.com).

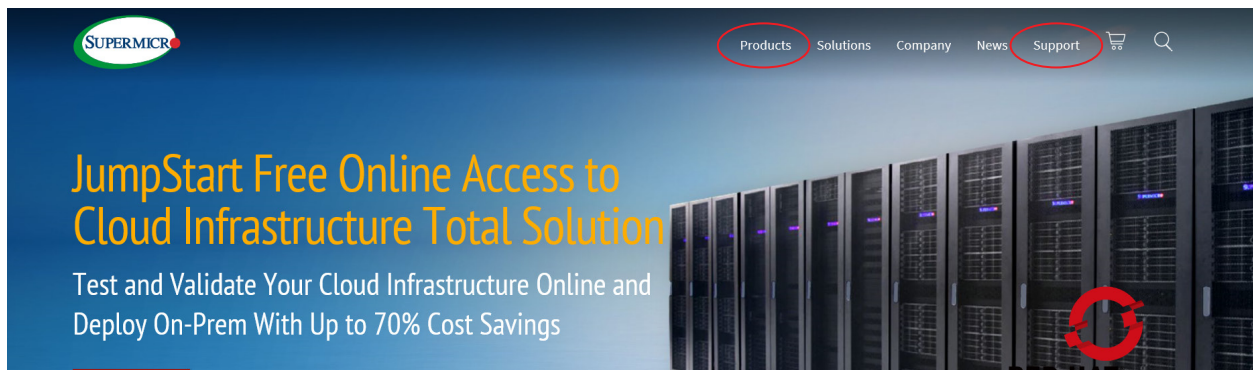

**Figure 7-1. Supermicro Website**

- Specifications for servers and other hardware are available by the **Products** option.
- The **Support** option offers downloads (manuals, BIOS/BMC, drivers, etc.), FAQs, RMA, warranty, and other service extensions.

#### ***Direct Links for the AS -1015SV-WTNRT System***

[AS -1015SV-WTNRT specifications page](#)

H13SVW-NT [motherboard page](#) for links to the Quick Reference Guide, User Manual, validated storage drives, etc.

#### ***Direct Links for General Support and Information***

[Frequently Asked Questions](#)

[Add-on card descriptions](#)

[TPM User Guide](#)

[BMC User Guide](#)

[SuperDoctor5 Large Deployment Guide](#)

For validated memory, use our [Product Resources page](#)

## Direct Links (continued)

[Product Matrices](#) page for links to tables summarizing specs for systems, motherboards, power supplies, riser cards, add-on cards, etc.

[Security Center](#) for recent security notices

[Supermicro Phone and Addresses](#)

## 7.2 Baseboard Management Controller (BMC)

The system supports the Baseboard Management Controller (BMC). BMC is used to provide remote access, monitoring and management. There are several BIOS settings that are related to BMC.

For general documentation and information on BMC, please visit our website at: [https://www.supermicro.com/manuals/other/BMC\\_IPMI\\_X13\\_H13.pdf](https://www.supermicro.com/manuals/other/BMC_IPMI_X13_H13.pdf).

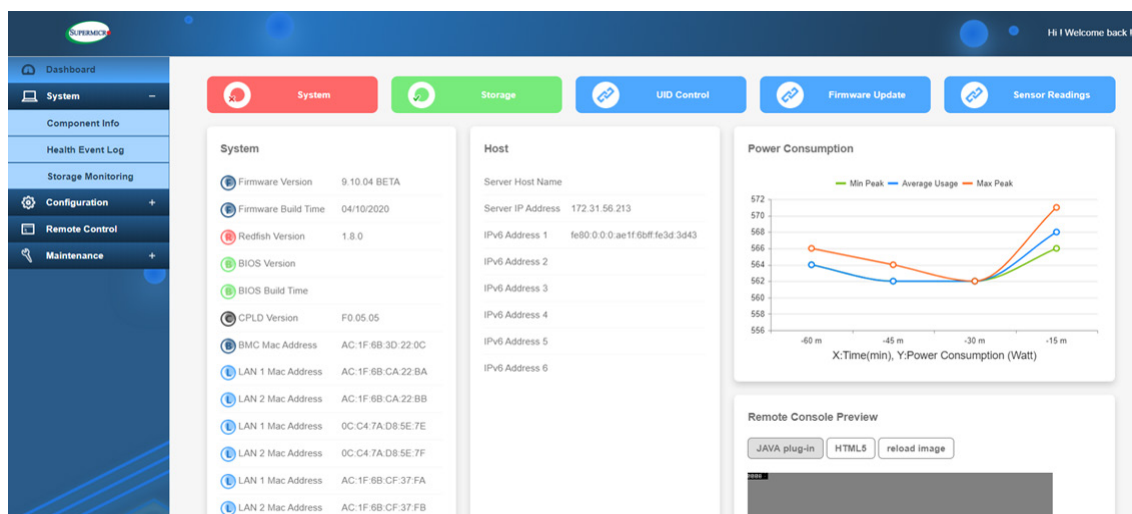

Figure 7-2. BMC Sample

## 7.3 Troubleshooting Procedures

Use the following procedures to troubleshoot your system. If you have followed all of the procedures below and still need assistance, refer to the "Technical Support Procedures' and/or 'Returning Merchandise for Service" section(s) in this chapter. Always disconnect the AC power cord before adding, changing or installing any non hot-swap hardware components.

### Before Power On

- Check that the power LED on the motherboard is on.
- Make sure that the power connector is connected to your power supply.
- Make sure that no short circuits exist between the motherboard and chassis.
- Disconnect all cables from the motherboard, including those for the keyboard and mouse.
- Remove all add-on cards.
- Install at least one DIMM, a CPU, and a heatsink (in that order), check all jumper settings. Make sure that the heatsink is fully seated.
- Use the correct type of onboard CMOS battery (CR2032) as recommended by the manufacturer. To avoid possible explosion, do not install the CMOS battery upside down.

### No Power

- Check that the power LED on the motherboard is on.
- Make sure that the power connector is connected to the power supply.
- Check that the motherboard battery still supplies approximately 3 VDC. If it does not, replace it.
- Check that the system input voltage is 100-120 V or 180-240 V.
- Turn the power switch on and off to test the system.

### No Video

- If the power is on but you have no video, remove all the add-on cards and cables.
- Check if memory module population is supported following guidelines, and re-seat memory
- DIMM module(s).

**Note:** If you are a system integrator, VAR or OEM, a POST diagnostics card is recommended.

## System Boot Failure

If the system does not display Power-On-Self-Test (POST) or does not respond after the power is turned on, try the following:

- Turn on the system with only one DIMM module installed. If the system boots, check for bad DIMM modules or slots by following the Memory Errors Troubleshooting procedure below.

## Memory Errors

- Make sure that the DIMM modules are properly and fully installed.
- Confirm that you are using the correct memory. Also, it is recommended that you use the same memory type and speed for all DIMMs in the system. See [Section 3.4](#) for memory details.
- Check for bad DIMM modules or slots by swapping modules between slots and noting the results.

## Losing the System Setup Configuration

- Always replace power supplies with the exact same model that came with the system. A poor quality power supply may cause the system to lose the CMOS setup configuration.
- Check that the motherboard battery still supplies approximately 3VDC. If it does not, replace it.

If the above steps do not fix the setup configuration problem, contact your vendor for repairs.

## When the System Becomes Unstable

***If the system becomes unstable during or after OS installation, check the following:***

- CPU/BIOS support: Make sure that your CPU is supported and that you have the latest BIOS installed in your system.
- Memory: Make sure that the memory modules are supported. Refer to the product page on our website at [www.supernmicro.com](http://www.supernmicro.com). Test the modules using **memtest86** or a similar utility.
- Storage drives: Make sure that all drives work properly. Replace if necessary.
- System cooling: Check that all heatsink fans and system fans work properly. Check the hardware monitoring settings in the BMC to make sure that the CPU and system temperatures are within the normal range. Also check the Control panel Overheat LED.

- Adequate power supply: Make sure that the power supply provides adequate power to the system. Make sure that all power connectors are connected. Refer to the Supermicro website for the minimum power requirements.
- Proper software support: Make sure that the correct drivers are used.

***If the system becomes unstable before or during OS installation, check the following:***

- Source of installation: Make sure that the devices used for installation are working properly, including boot devices.
- Cable connection: Check to make sure that all cables are connected and working properly.
- Use the minimum configuration for troubleshooting: Remove all unnecessary components (starting with add-on cards first), and use the minimum configuration (but with a CPU and a memory module installed) to identify the trouble areas.
- Identify a bad component by isolating it. Check and change one component at a time.
  - Remove a component in question from the chassis, and test it in isolation. Replace it if necessary.
  - Or swap in a new component for the suspect one.
  - Or install the possibly defective component into a known good system. If the new system works, the component is likely not the cause or the problem.

## 7.4 BIOS Error Beep (POST) Codes

During the POST (Power-On Self-Test) routines, which are performed each time the system is powered on, errors may occur.

**Non-fatal errors** are those which, in most cases, allow the system to continue the boot-up process. The error messages normally appear on the screen.

**Fatal errors** are those which will not allow the system to continue the boot-up procedure. If a fatal error occurs, you should consult with your system manufacturer for possible repairs. These fatal errors are usually communicated through a series of audible beeps. The table below lists some common errors and their corresponding beep codes encountered by users.

BIOS Error Beep (POST) Codes		
Beep Code Error	Message	Description
1 short	Refresh	Circuits have been reset (Ready to power up)
5 short, 1 long	Memory error	No memory detected in system
5 long, 2 short	Display memory read/write error	Video adapter missing or with faulty memory
1 long continuous	System OH	System overheat condition

### Additional BIOS POST Codes

The AMI BIOS supplies additional checkpoint codes, which are documented online at <http://www.supermicro.com/support/manuals/> ("AMI BIOS POST Codes User's Guide").

When BIOS performs the Power On Self Test, it writes checkpoint codes to I/O port 0080h. If the computer cannot complete the boot process, a diagnostic card can be attached to the computer to read I/O port 0080h (Supermicro p/n AOC-LPC80-20).

For information on AMI updates, please refer to <http://www.ami.com/products/>.

## 7.5 Crash Dump Using BMC

In the event of a processor internal error (IERR) that crashes your system, you may want to provide information to support staff. You can download a crash dump of status information using BMC. The BMC manual is available at <https://www.supermicro.com/en/solutions/management-software/bmc-resources>.

### Check BMC Error Log

1. Access the BMC web interface.
2. Click the **Server Health** tab, then **Event Log** to verify an IERR error.

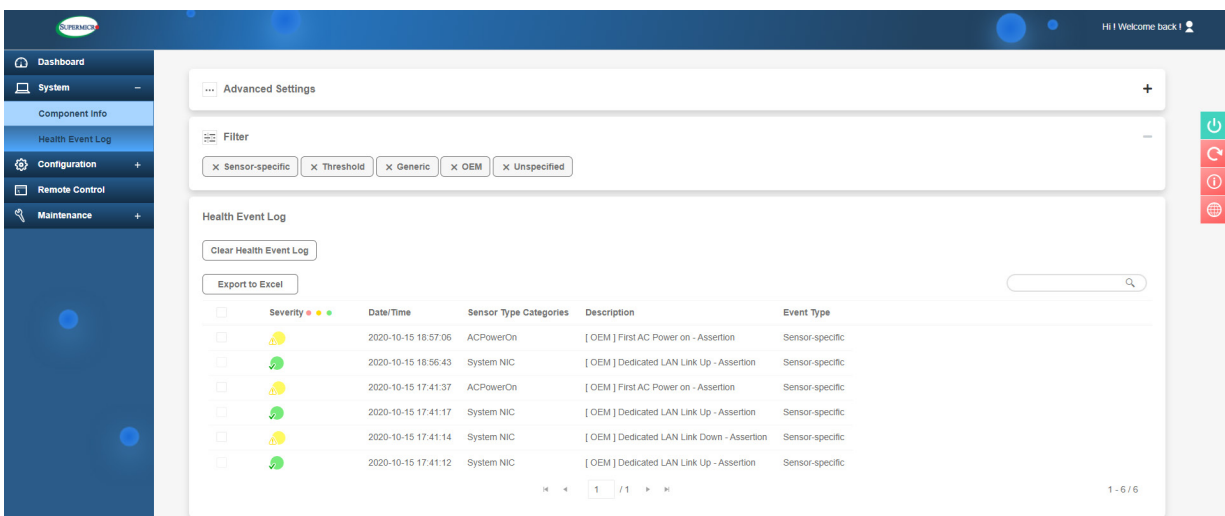

Figure 7-3. BMC Event Log

In the event of an IERR, the BMC executes a crash dump. You must download the crash dump and save it.

## 7.6 UEFI BIOS Recovery

**Warning:** Do not upgrade the BIOS unless your system has a BIOS-related issue. Flashing the wrong BIOS can cause irreparable damage to the system. In no event shall Supermicro be liable for direct, indirect, special, incidental, or consequential damages arising from a BIOS update. If you do update the BIOS, do not shut down or reset the system while the BIOS is updating to avoid possible boot failure.

### Overview

The Unified Extensible Firmware Interface (UEFI) provides a software-based interface between the operating system and the platform firmware in the pre-boot environment. The UEFI specification supports an architecture-independent mechanism for add-on card initialization to allow the UEFI OS loader, which is stored in the add-on card, to boot the system. The UEFI offers clean, hands-off control to a computer system at bootup.

### Recovering the UEFI BIOS Image

A UEFI BIOS flash chip consists of a recovery BIOS block and a main BIOS block (a main BIOS image). The boot block contains critical BIOS codes, including memory detection and recovery codes for the user to flash a new BIOS image if the original main BIOS image is corrupted. When the system power is on, the boot block codes execute first. Once it is completed, the main BIOS code will continue with system initialization and bootup.

### Recovering the Main BIOS Block with a USB Device

If the BIOS file is corrupted and the system is not able to boot up, this feature will allow you to recover the BIOS image using a USB-attached device. A USB flash or media drive can be used for this purpose. Please note that a USB hard disk drive is NOT supported. Follow the procedures on the next page to recover the BIOS.

1. Using a different machine, copy the "Super.ROM" binary image file into the disc Root "\ " directory of a USB flash or media drive with FAT16 or FAT32 format and rename the file to SUPER.ROM.

**Note:** If you cannot locate the "Super.ROM" file in your drive disk, visit our website at [www.supermicro.com](http://www.supermicro.com) to download the correct BIOS image into a USB flash device and rename it "SUPER.ROM".

2. While the system is turned off, insert the USB device that contains the new BIOS binary image (SUPER.ROM).
3. Power on the system.
4. After the system is turned on, the system will enter the BIOS Recovery menu. Select "Proceed with flash update" to start the BIOS recovery process. **DO NOT INTERRUPT THIS PROCESS UNTIL IT FINISHED!**



5. After the BIOS recovery process is complete, press any key to reboot the system.

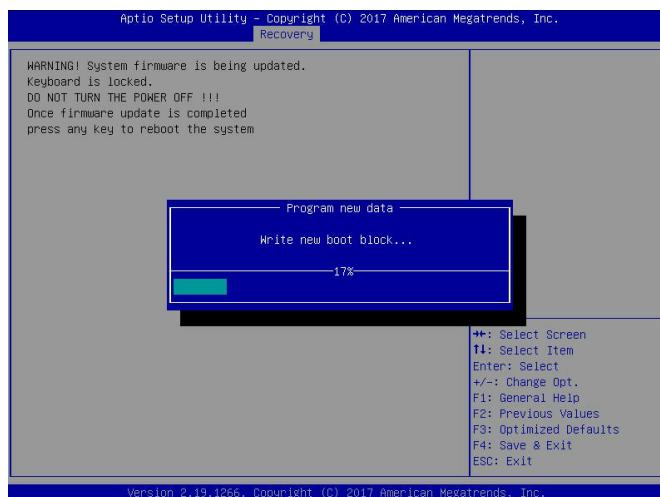
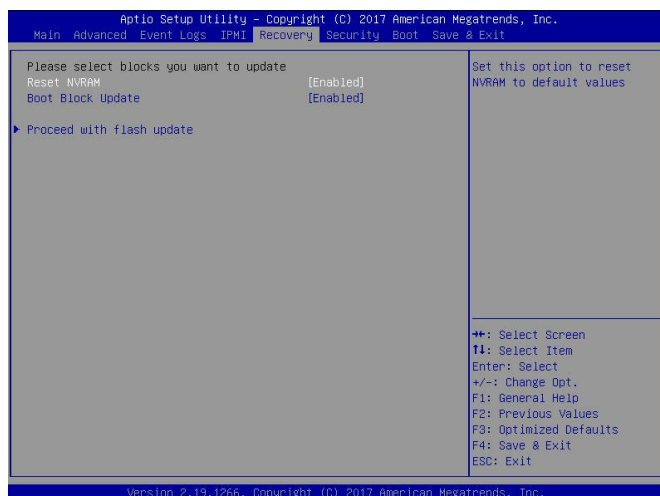

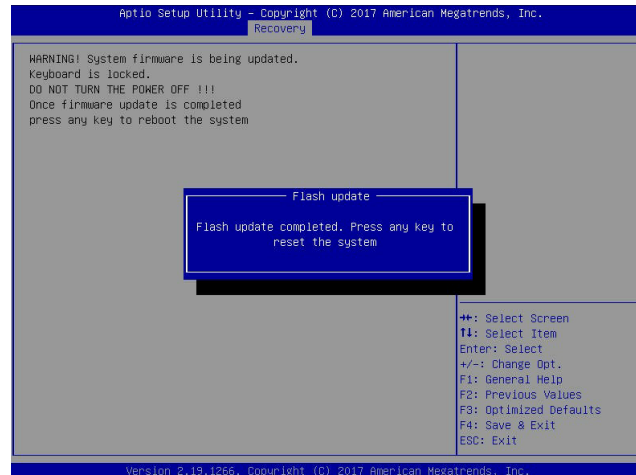
**Notes:**

- The BIOS recovery (SUPER.ROM) will not work if BIOS suffered a multi-block crash.
- If you have purchased an OOB license, you can do a BIOS flash again through BMC WebGUI or SUM. Please refer to these SUPERMICRO software-related videos:

Activate OOB license: [https://www.youtube.com/watch?v=V4spX\\_DOV7I](https://www.youtube.com/watch?v=V4spX_DOV7I)

SUPERMICO BIOS Update: <https://www.youtube.com/watch?v=S8z6iOEHGwY>

- If the BIOS flash recovery fails, contact our RMA Department to have the BIOS chip reprogrammed. This will require shipping the board to Supermicro for repair.

Submit your RMA request at <https://www.supermicro.com/support/rma>

Please make sure to follow all instructions when returning the motherboard.

## 7.7 CMOS Clear

JBT1 is used to clear CMOS, which will also clear any passwords. Instead of pins, this jumper consists of contact pads to prevent accidentally clearing the contents of CMOS.

### **To Clear CMOS**

1. First [power down](#) the system completely.
2. [Remove chassis cover](#) to access the motherboard.
3. [Remove the onboard battery](#) from the motherboard.
4. Short the CMOS pads with a metal object such as a small screwdriver for at least four seconds.
5. Remove the screwdriver or shorting device.
6. Re-install the battery.
7. Replace the cover, reconnect the power cords and power on the system.

**Notes:** Clearing CMOS will also clear all passwords.

*Do not use the PW\_ON connector to clear CMOS.*



JBT1 contact pads

## 7.8 Where to Get Replacement Components

If you need replacement parts for your system, to ensure the highest level of professional service and technical support, purchase exclusively from our Supermicro Authorized Distributors/System Integrators/Resellers. A list can be found at: <http://www.supermicro.com>. Click the "Where to Buy" tab.

## 7.9 BMC Reset

The BMC can be reset using the button on the front control panel or on the chassis rear.

- **Reset**—Press and hold the button. After six seconds, the LED blinks at 2 Hz. The BMC resets and the reset duration is approximately 250 ms. Then the BMC starts to boot.
- **Restore factory default configuration**—Hold the button for twelve seconds. The LED blinks at 4 Hz while defaults are configured.
- **Firmware update**—the UID LED blinks at 10 Hz during a firmware update.

BMC Reset Options		
Event	UID LED	BMC Heartbeat LED
Reset	Blue, Blinks at 2 Hz	Green, solid
Restore Defaults	Blue, Blinks at 4 Hz	Off
Update	Blue, Blinks at 10 Hz	

## 7.10 Reporting an Issue

### Technical Support Procedures

Before contacting Technical Support, please take the following steps. If your system was purchased through a distributor or reseller, please contact them for troubleshooting services. They have the best knowledge of your specific system configuration.

1. Please review the [Troubleshooting Procedures](#) in this manual and [Frequently Asked Questions](#) on our website before contacting Technical Support.
2. BIOS upgrades can be downloaded from our website. **Note:** Not all BIOS can be flashed depending on the modifications to the boot block code.
3. If you still cannot resolve the problem, include the following information when contacting us for technical support:
  - System, motherboard, and chassis model numbers and PCB revision number
  - BIOS release date/version (this can be seen on the initial display when your system first boots up)
  - System configuration

An example of a Technical Support form is posted on our [website](#). Distributors: For immediate assistance, please have your account number ready when contacting our technical support department by email.

## Returning Merchandise for Service

A receipt or copy of your invoice marked with the date of purchase is required before any warranty service will be rendered. You can obtain service by calling your vendor for a Returned Merchandise Authorization (RMA) number. When returning to the manufacturer, the RMA number should be prominently displayed on the outside of the shipping carton, and mailed prepaid or hand-carried. Shipping and handling charges will be applied for all orders that must be mailed when service is complete.

For faster service, RMA authorizations may be requested online (<http://www.supermicro.com/support/rma/>).

Whenever possible, repack the chassis in the original Supermicro carton, using the original packaging material. If these are no longer available, be sure to pack the chassis securely, using packaging material to surround the chassis so that it does not shift within the carton and become damaged during shipping.

This warranty only covers normal consumer use and does not cover damages incurred in shipping or from failure due to the alteration, misuse, abuse or improper maintenance of products.

During the warranty period, contact your distributor first for any product problems.

## 7.11 Feedback

Supermicro values your feedback as we strive to improve our customer experience in all facets of our business. Please email us at [techwriterteam@supermicro.com](mailto:techwriterteam@supermicro.com) to provide feedback on our manuals.

## Appendix A

# Standardized Warning Statements for AC Systems

### About Standardized Warning Statements

The following statements are industry standard warnings, provided to warn the user of situations which have the potential for bodily injury. Should you have questions or experience difficulty, contact Supermicro's Technical Support department for assistance. Only certified technicians should attempt to install or configure components.

Read this appendix in its entirety before installing or configuring components in the Supermicro chassis.

These warnings may also be found on our website at [http://www.supermicro.com/about/policies/safety\\_information.cfm](http://www.supermicro.com/about/policies/safety_information.cfm).

### Warning Definition



**Warning!** This warning symbol means danger. You are in a situation that could cause bodily injury. Before you work on any equipment, be aware of the hazards involved with electrical circuitry and be familiar with standard practices for preventing accidents.

#### 警告の定義

この警告サインは危険を意味します。

人身事故につながる可能性がありますので、いずれの機器でも動作させる前に、電気回路に含まれる危険性に注意して、標準的な事故防止策に精通して下さい。

此警告符号代表危險。

您正处于可能受到严重伤害的工作环境中。在您使用设备开始工作之前，必须充分意识到触电的危险，并熟练掌握防止事故发生的标准工作程序。请根据每项警告结尾的声明号码找到此设备的安全性警告说明的翻译文本。

此警告符號代表危險。

您正處於可能身體可能會受損傷的工作環境中。在您使用任何設備之前，請注意觸電的危險，並且要熟悉預防事故發生的標準工作程序。請依照每一注意事項後的號碼找到相關的翻譯說明內容。

## Warnung

### WICHTIGE SICHERHEITSHINWEISE

Dieses Warnsymbol bedeutet Gefahr. Sie befinden sich in einer Situation, die zu Verletzungen führen kann. Machen Sie sich vor der Arbeit mit Geräten mit den Gefahren elektrischer Schaltungen und den üblichen Verfahren zur Vorbeugung vor Unfällen vertraut. Suchen Sie mit der am Ende jeder Warnung angegebenen Anweisungsnummer nach der jeweiligen Übersetzung in den übersetzten Sicherheitshinweisen, die zusammen mit diesem Gerät ausgeliefert wurden.

BEWAHREN SIE DIESE HINWEISE GUT AUF.

### INSTRUCCIONES IMPORTANTES DE SEGURIDAD

Este símbolo de aviso indica peligro. Existe riesgo para su integridad física. Antes de manipular cualquier equipo, considere los riesgos de la corriente eléctrica y familiarícese con los procedimientos estándar de prevención de accidentes. Al final de cada advertencia encontrará el número que le ayudará a encontrar el texto traducido en el apartado de traducciones que acompaña a este dispositivo.

GUARDE ESTAS INSTRUCCIONES.

### IMPORTANTES INFORMATIONS DE SÉCURITÉ

Ce symbole d'avertissement indique un danger. Vous vous trouvez dans une situation pouvant entraîner des blessures ou des dommages corporels. Avant de travailler sur un équipement, soyez conscient des dangers liés aux circuits électriques et familiarisez-vous avec les procédures couramment utilisées pour éviter les accidents. Pour prendre connaissance des traductions des avertissements figurant dans les consignes de sécurité traduites qui accompagnent cet appareil, référez-vous au numéro de l'instruction situé à la fin de chaque avertissement.

CONSERVEZ CES INFORMATIONS.

## תקנון הזהרות אזהרה

הזהרות הבאות הן אזהרות על פי תקני התעשייה, על מנת להזהיר את המשתמש מפני חבלה פיזית אפשרית. במידה ויש שאלות או היתקלות בבעיה כלשהי, יש ליצור קשר עם מחלקת תמיכה טכנית של סופרמיקרו. טכנאים מוסמכים בלבד רשאים להתקין או להגדיר את הרכיבים. יש לקרוא את הנספח במלואו לפני התקנת או הגדרת הרכיבים במארזי סופרמיקרו.

اَكْ ف حالة وُكِي اَي تتسبب ف اصابة جسدهُ هذا الزهز عْ خطر! تحذُرُ .  
 قبل اَي تعول على اَي هعدات، كي على علن بالوخاطز ال اُجوة عي الذوائر  
 الكهزبائِة  
 وكي على دراةُ بالووارسات النقاىِة لو عْ وقع اَي حادث  
 استخدم رقن الب اى الو صُص ف هاةُ كل تحذُرُ للعشر تزجوتها

안전을 위한 주의사항

경고!

이 경고 기호는 위험이 있음을 알려 줍니다. 작업자의 신체에 부상을 야기 할 수 있는 상태에 있게 됩니다. 모든 장비에 대한 작업을 수행하기 전에 전기회로와 관련된 위험요소들을 확인하시고 사전에 사고를 방지할 수 있도록 표준 작업절차를 준수해 주시기 바랍니다.

해당 번역문을 찾기 위해 각 경고의 마지막 부분에 제공된 경고문 번호를 참조하십시오

## BELANGRIJKE VEILIGHEIDSINSTRUCTIES

Dit waarschuwings symbool betekent gevaar. U verkeert in een situatie die lichamelijk letsel kan veroorzaken. Voordat u aan enige apparatuur gaat werken, dient u zich bewust te zijn van de bij een elektrische installatie betrokken risico's en dient u op de hoogte te zijn van de standaard procedures om ongelukken te voorkomen. Gebruik de nummers aan het eind van elke waarschuwing om deze te herleiden naar de desbetreffende locatie.

BEWAAR DEZE INSTRUCTIES

## Installation Instructions



**Warning!** Read the installation instructions before connecting the system to the power source.

設置手順書

システムを電源に接続する前に、設置手順書をお読み下さい。

警告

将此系统连接电源前,请先阅读安装说明。

警告

將系統與電源連接前，請先閱讀安裝說明。

**Warnung**

Vor dem Anschließen des Systems an die Stromquelle die Installationsanweisungen lesen.

**¡Advertencia!**

Lea las instrucciones de instalación antes de conectar el sistema a la red de alimentación.

**Attention**

Avant de brancher le système sur la source d'alimentation, consulter les directives d'installation.

יש לקרוא את הוראות התקנה לפני חיבור המערכת למקור מתח.

اقرأ إرشادات التركيب قبل توصيل النظام إلى مصدر للطاقة

시스템을 전원에 연결하기 전에 설치 안내를 읽어주십시오.

**Waarschuwing**

Raadpleeg de installatie-instructies voordat u het systeem op de voedingsbron aansluit.

**Circuit Breaker**

**Warning!** This product relies on the building's installation for short-circuit (overcurrent) protection. Ensure that the protective device is rated not greater than: 250 V, 20 A.

**サーキット・ブレーカー**

この製品は、短絡(過電流)保護装置がある建物での設置を前提としています。

保護装置の定格が250 V、20 Aを超えないことを確認下さい。

**警告**

此产品的短路(过载电流)保护由建筑物的供电系统提供,确保短路保护设备的额定电流不大于250V,20A。

**警告**

此產品的短路(過載電流)保護由建築物的供電系統提供,確保短路保護設備的額定電流不大於250V,20A。

**Warnung**

Dieses Produkt ist darauf angewiesen, dass im Gebäude ein Kurzschluss- bzw. Überstromschutz installiert ist. Stellen Sie sicher, dass der Nennwert der Schutzvorrichtung nicht mehr als: 250 V, 20 A beträgt.

**¡Advertencia!**

Este equipo utiliza el sistema de protección contra cortocircuitos (o sobrecorrientes) del edificio. Asegúrese de que el dispositivo de protección no sea superior a: 250 V, 20 A.

**Attention**

Pour ce qui est de la protection contre les courts-circuits (surtension), ce produit dépend de l'installation électrique du local. Vérifiez que le courant nominal du dispositif de protection n'est pas supérieur à :250 V, 20 A.

מוצר זה מסתמך על הגנה המותקנת במבנים למניעת קצר חשמלי. יש לוודא כי המכשיר המגן מפני הקצר החשמלי הוא לא יותר מ-250VDC, 20A

هذا المنتج يعتمد على معدات الحماية مه الدوائر القصيرة التي تم تثبيتها في المبنى  
تأكد من أن تقييم الجهاز الوقائي ليس أكثر من : 20A, 250V

**경고!**

이 제품은 전원의 단락(과전류)방지에 대해서 전적으로 건물의 관련 설비에 의존합니다. 보호장치의 정격이 반드시 250V(볼트), 20A(암페어)를 초과하지 않도록 해야 합니다.

**Waarschuwing**

Dit product is afhankelijk van de kortsluitbeveiliging (overspanning) van uw elektrische installatie. Controleer of het beveiligde apparaat niet groter gedimensioneerd is dan 250V, 20A.

## Power Disconnection Warning



**Warning!** The system must be disconnected from all sources of power and the power cord removed from the power supply module(s) before accessing the chassis interior to install or remove system components (except for hot-swap components).



### 電源切断の警告

システムコンポーネントの取り付けまたは取り外しのために、シャーシ内部にアクセスするには、システムの電源はすべてのソースから切断され、電源コードは電源モジュールから取り外す必要があります。

### 警告

在你打开机箱并安装或移除内部器件前,必须将系统完全断电,并移除电源线。

### 警告

在您打開機殼安裝或移除內部元件前，必須將系統完全斷電，並移除電源線。

### Warnung

Das System muss von allen Quellen der Energie und vom Netzanschlusskabel getrennt sein, das von den Spg.Versorgungsteilmodulen entfernt wird, bevor es auf den Chassisinnenraum zurückgreift, um Systemsbestandteile anzubringen oder zu entfernen.

### ¡Advertencia!

El sistema debe ser disconnected de todas las fuentes de energía y del cable eléctrico quitado de los módulos de fuente de alimentación antes de tener acceso el interior del chasis para instalar o para quitar componentes de sistema.

### Attention

Le système doit être débranché de toutes les sources de puissance ainsi que de son cordon d'alimentation secteur avant d'accéder à l'intérieur du chassis pour installer ou enlever des composants de système.

אזהרה מפני ניתוק חשמלי

אזהרה!

יש לנתק את המערכת מכל מקורות החשמל ויש להסיר את כבל החשמלי מהספק לפני גישה לחלק הפנימי של המארז לצורך התקנת או הסרת רכיבים.

يجب فصل انظاؤ من جميع مصادر انطاقت وإزانت سهك انكهرباء من وحدة امداد انطاقت قيم

انصل إلى امناطق انداخييت نههيكم نشييج أو إزانت مكناث الجهاز

경고!

시스템에 부품들을 장착하거나 제거하기 위해서는 새시 내부에 접근하기 전에 반드시 전원 공급장치로부터 연결되어있는 모든 전원과 전기코드를 분리해주어야 합니다.

Waarschuwing

Voordat u toegang neemt tot het binnenwerk van de behuizing voor het installeren of verwijderen van systeem onderdelen, dient u alle spanningsbronnen en alle stroomkabels aangesloten op de voeding(en) van de behuizing te verwijderen

## Equipment Installation



**Warning!** Only authorized personnel and qualified service persons should be allowed to install, replace, or service this equipment.

機器の設置

トレーニングを受け認定された人だけがこの装置の設置、交換、またはサービスを許可されています。

警告

只有经过培训且具有资格的人员才能进行此设备的安装、更换和维修。

警告

只有經過受訓且具資格人員才可安裝、更換與維修此設備。

Warnung

Nur autorisiertes Personal und qualifizierte Servicetechniker dürfen dieses Gerät installieren, austauschen oder warten..

¡Advertencia!

Sólo el personal autorizado y el personal de servicio calificado deben poder instalar, reemplazar o dar servicio a este equipo.

**Attention**

Seul le personnel autorisé et le personnel de maintenance qualifié doivent être autorisés à installer, remplacer ou entretenir cet équipement..

אזהרה!

יש לאפשר רק צוות מורשה ואנשי שירות מוסמכים להתקין, להחליף או לטפל בציוד זה.

ينبغي السماح فقط للموظفين المعتمدين وأفراد الخدمة المؤهلين بتركيب هذا الجهاز أو استبداله أو صيانته.

**경고!**

승인된 직원과 자격을 갖춘 서비스 담당자만이 이 장비를 설치, 교체 또는 서비스할 수 있습니다.

**Waarschuwing**

Alleen geautoriseerd personeel en gekwalificeerd onderhoudspersoneel mag deze apparatuur installeren, vervangen of onderhouden..

**Restricted Area**

**Warning!** This unit is intended for installation in restricted access areas. A restricted access area can be accessed only through the use of a special tool, lock and key, or other means of security. (This warning does not apply to workstations).

**アクセス制限区域**

このユニットは、アクセス制限区域に設置されることを想定しています。

アクセス制限区域は、特別なツール、鍵と錠前、その他のセキュリティの手段を用いてのみ出入りが可能です。

**警告**

此部件应安装在限制进出的场所，限制进出的场所指只能通过使用特殊工具、锁和钥匙或其它安全手段进出的场所。

**警告**

此裝置僅限安裝於進出管制區域，進出管制區域係指僅能以特殊工具、鎖頭及鑰匙或其他安全方式才能進入的區域。

**Warnung**

Diese Einheit ist zur Installation in Bereichen mit beschränktem Zutritt vorgesehen. Der Zutritt zu derartigen Bereichen ist nur mit einem Spezialwerkzeug, Schloss und Schlüssel oder einer sonstigen Sicherheitsvorkehrung möglich.

**¡Advertencia!**

Esta unidad ha sido diseñada para instalación en áreas de acceso restringido. Sólo puede obtenerse acceso a una de estas áreas mediante la utilización de una herramienta especial, cerradura con llave u otro medio de seguridad.

**Attention**

Cet appareil doit être installée dans des zones d'accès réservés. L'accès à une zone d'accès réservé n'est possible qu'en utilisant un outil spécial, un mécanisme de verrouillage et une clé, ou tout autre moyen de sécurité.

אזור עם גישה מוגבלת

אזהרה!

יש להתקין את היחידה באזורים שיש בהם הגבלת גישה. הגישה ניתנת בעזרת 'מפתח, מנעול וכד' (כלי אבטחה בלבד).

تخصيص هذه انحدة نترك بُها ف مناطق محظورة تم .

،ممكن اننصل إن منطقت محظورة فقط من خلال استخذاو أداة خاصت أو أ وس هُت أخري نلالأمما ققم ومفتاح

**경고!**

이 장치는 접근이 제한된 구역에 설치하도록 되어있습니다. 특수도구, 잠금 장치 및 키, 또는 기타 보안 수단을 통해서만 접근 제한 구역에 들어갈 수 있습니다.

**Waarschuwing**

Dit apparaat is bedoeld voor installatie in gebieden met een beperkte toegang. Toegang tot dergelijke gebieden kunnen alleen verkregen worden door gebruik te maken van speciaal gereedschap, slot en sleutel of andere veiligheidsmaatregelen.

## Battery Handling



**Warning!** There is the danger of explosion if the battery is replaced incorrectly. Replace the battery only with the same or equivalent type recommended by the manufacturer. Dispose of used batteries according to the manufacturer's instructions

### 電池の取り扱い

電池交換が正しく行われなかった場合、破裂の危険性があります。交換する電池はメーカーが推奨する型、または同等のものを使用下さい。使用済電池は製造元の指示に従って処分して下さい。

### 警告

電池更換不當會有爆炸危險。請只使用同類電池或制造商推荐的功能相当的電池更換原有電池。請按制造商的說明處理廢舊電池。

### 警告

電池更換不當會有爆炸危險。請使用製造商建議之相同或功能相當的電池更換原有電池。請按照製造商的說明指示處理廢棄舊電池。

### Warnung

Bei Einsetzen einer falschen Batterie besteht Explosionsgefahr. Ersetzen Sie die Batterie nur durch den gleichen oder vom Hersteller empfohlenen Batterietyp. Entsorgen Sie die benutzten Batterien nach den Anweisungen des Herstellers.

### Attention

Danger d'explosion si la pile n'est pas remplacée correctement. Ne la remplacer que par une pile de type semblable ou équivalent, recommandée par le fabricant. Jeter les piles usagées conformément aux instructions du fabricant.

### ¡Advertencia!

Existe peligro de explosión si la batería se reemplaza de manera incorrecta. Reemplazar la batería exclusivamente con el mismo tipo o el equivalente recomendado por el fabricante. Desechar las baterías gastadas según las instrucciones del fabricante.

אזהרה!

קיימת סכנת פיצוץ של הסוללה במידה והוחלפה בדרך לא תקינה. יש להחליף את הסוללה בסוג התואם מחברת יצרן מומלצת. סילוק הסוללות המשומשות יש לבצע לפי הוראות היצרן.

هناك خطر من انفجار في حالة اسبدال البطارية بطريقة غير صحيحة فعلى  
اسبدال البطارية  
فقط بنفس النوع أو ما يعادلها مما أوصت به الشركة المصنعة  
جخلص من البطاريات المسحمة وفقا لعمليات الشركة الصانعة

경고!

배터리가 올바르게 교체되지 않으면 폭발의 위험이 있습니다. 기존 배터리와 동일하거나 제조사에서 권장하는 동등한 종류의 배터리로만 교체해야 합니다. 제조사의 안내에 따라 사용된 배터리를 처리하여 주십시오.

Waarschuwing

Er is ontplofingsgevaar indien de batterij verkeerd vervangen wordt. Vervang de batterij slechts met hetzelfde of een equivalent type die door de fabrikant aanbevolen wordt. Gebruikte batterijen dienen overeenkomstig fabrieksvoorschriften afgevoerd te worden.

## Redundant Power Supplies



**Warning!** This unit might have more than one power supply connection. All connections must be removed to de-energize the unit.

冗長電源装置

このユニットは複数の電源装置が接続されている場合があります。

ユニットの電源を切るためには、すべての接続を取り外さなければなりません。

警告

此部件连接的电源可能不止一个，必须将所有电源断开才能停止给该部件供电。

警告

此装置连接的电源可能不只一个，必须切断所有电源才能停止对该装置的供电。

Warnung

Dieses Gerät kann mehr als eine Stromzufuhr haben. Um sicherzustellen, dass der Einheit kein Strom zugeführt wird, müssen alle Verbindungen entfernt werden.

**¡Advertencia!**

Puede que esta unidad tenga más de una conexión para fuentes de alimentación. Para cortar por completo el suministro de energía, deben desconectarse todas las conexiones.

**Attention**

Cette unité peut avoir plus d'une connexion d'alimentation. Pour supprimer toute tension et tout courant électrique de l'unité, toutes les connexions d'alimentation doivent être débranchées.

אם קיים יותר מספק אחד

אזהרה!

ליחידה יש יותר מחיבור אחד של ספק. יש להסיר את כל החיבורים על מנת לרוקן את היחידה.

قد يكون لهذا الجهاز عدة اتصالات بوحدات امداد الطاقة .

يجب إزالة كافة الاتصالات لعسل الوحدة عن الكهرباء

**경고!**

이 장치에는 한 개 이상의 전원 공급 단자가 연결되어 있을 수 있습니다. 이 장치에 전원을 차단하기 위해서는 모든 연결 단자를 제거해야만 합니다.

**Waarschuwing**

Deze eenheid kan meer dan één stroomtoevoeraansluiting bevatten. Alle aansluitingen dienen verwijderd te worden om het apparaat stroomloos te maken.

## Backplane Voltage



**Warning!** Hazardous voltage or energy is present on the backplane when the system is operating. Use caution when servicing.

バックプレーンの電圧

システムの稼働中は危険な電圧または電力が、バックプレーン上にかかっています。

修理する際には注意ください。

警告

当系统正在进行时，背板上有很危险的电压或能量，进行维修时务必小心。

警告

當系統正在進行時，背板上有危險的電壓或能量，進行維修時務必小心。

Warnung

Wenn das System in Betrieb ist, treten auf der Rückwandplatine gefährliche Spannungen oder Energien auf. Vorsicht bei der Wartung.

¡Advertencia!

Cuando el sistema está en funcionamiento, el voltaje del plano trasero es peligroso. Tenga cuidado cuando lo revise.

Attention

Lorsque le système est en fonctionnement, des tensions électriques circulent sur le fond de panier. Prendre des précautions lors de la maintenance.

מתח בפנל האחורי

אזהרה!

קיימת סכנת מתח בפנל האחורי בזמן תפעול המערכת. יש להיזהר במהלך העבודה.

هناك خطر من التيار الكهربائي أو الطاقة المتجددة على اللوحة  
عندما يكون النظام يعمل كه حذرا عند خدمة هذا الجهاز

경고!

시스템이 동작 중일 때 후면판 (Backplane)에는 위험한 전압이나 에너지가 발생 합니다.  
서비스 작업 시 주의하십시오.

Waarschuwing

Een gevaarlijke spanning of energie is aanwezig op de backplane wanneer het systeem in gebruik is. Voorzichtigheid is geboden tijdens het onderhoud.

## Comply with Local and National Electrical Codes



**Warning!** Installation of the equipment must comply with local and national electrical codes.

地方および国の電気規格に準拠

機器の取り付けはその地方および国の電気規格に準拠する必要があります。

警告

设备安装必须符合本地与本国电气法规。

警告

設備安裝必須符合本地與本國電氣法規。

Warnung

Die Installation der Geräte muss den Sicherheitsstandards entsprechen.

¡Advertencia!

La instalación del equipo debe cumplir con las normas de electricidad locales y nacionales.

Attention

L'équipement doit être installé conformément aux normes électriques nationales et locales.

תיאום חוקי החשמל הארצי  
אזהרה!  
התקנת הציוד חייבת להיות תואמת לחוקי החשמל המקומיים והארציים.

تركيب المعدات الكهربائية يجب أن يمتثل للقوايه المحلية والبطية المتعلقة  
بالكهرباء

경고!

현 지역 및 국가의 전기 규정에 따라 장비를 설치해야 합니다.

Waarschuwing

Bij installatie van de apparatuur moet worden voldaan aan de lokale en nationale elektriciteitsvoorschriften.

## Product Disposal



**Warning!** Ultimate disposal of this product should be handled according to all national laws and regulations.

製品の廃棄

この製品を廃棄処分する場合、国の関係する全ての法律・条例に従い処理する必要があります。

警告

本产品的废弃处理应根据所有国家的法律和规章进行。

警告

本產品的廢棄處理應根據所有國家的法律和規章進行。

Warnung

Die Entsorgung dieses Produkts sollte gemäß allen Bestimmungen und Gesetzen des Landes erfolgen.

¡Advertencia!

Al deshacerse por completo de este producto debe seguir todas las leyes y reglamentos nacionales.

## Attention

La mise au rebut ou le recyclage de ce produit sont généralement soumis à des lois et/ou directives de respect de l'environnement. Renseignez-vous auprès de l'organisme compétent.

סילוק המוצר

אזהרה!

סילוק סופי של מוצר זה חייב להיות בהתאם להנחיות וחוקי המדינה.

التخلص النهائي من هذا المنتج ينبغي التعامل معه وفقا لجميع القوانين واللوائح الوطنية عند

경고!

이 제품은 해당 국가의 관련 법규 및 규정에 따라 폐기되어야 합니다.

## Waarschuwing

De uiteindelijke verwijdering van dit product dient te geschieden in overeenstemming met alle nationale wetten en reglementen.

## Fan Warning



**Warning!** Hazardous moving parts. Keep away from moving fan blades. The fans might still be turning when you remove the fan assembly from the chassis. Keep fingers, screwdrivers, and other objects away from the openings in the fan assembly's housing.

ファンの警告

警告!回転部品に注意。運転中は回転部(羽根)に触れないでください。シャーシから冷却ファン装置を取り外した際、ファンがまだ回転している可能性があります。ファンの開口部に、指、ドライバー、およびその他のものを近づけないで下さい。

警告!

警告! 危險的可移動性零件。請務必與轉動的风扇叶片保持距離。當您從機架移除風扇裝置，風扇可能仍在轉動。小心不要將手指、螺絲起子和其他物品太靠近風扇

警告

危險的可移動性零件。請務必與轉動的风扇叶片保持距離。當您從機架移除風扇裝置，風扇可能仍在轉動。小心不要將手指、螺絲起子和其他物品太靠近風扇。

**Warnung**

Gefährlich Bewegende Teile. Von den bewegenden Lüfterblätter fern halten. Die Lüfter drehen sich u. U. noch, wenn die Lüfterbaugruppe aus dem Chassis genommen wird. Halten Sie Finger, Schraubendreher und andere Gegenstände von den Öffnungen des Lüftergehäuses entfernt.

**¡Advertencia!**

Riesgo de piezas móviles. Mantener alejado de las aspas del ventilador. Los ventiladores podran dar vuelta cuando usted quite el montaje del ventilador del chasis. Mantenga los dedos, los destornilladores y todos los objetos lejos de las aberturas del ventilador

**Attention**

Pieces mobiles dangereuses. Se tenir a l'écart des lames du ventilateur Il est possible que les ventilateurs soient toujours en rotation lorsque vous retirerez le bloc ventilateur du châssis. Prenez garde à ce que doigts, tournevis et autres objets soient éloignés du logement du bloc ventilateur.

**אזהרה!**

חלקים נעים מסוכנים. התרחק מלהבי המאוורר בפעולה כאשר מסירים את חלקי המאוורר מהמארז, יתכן והמאווררים עדיין עובדים. יש להרחיק למרחק בטוח את האצבעות וכלי עבודה שונים מהפתחים בתוך המאוורר

تحذير! أجزاء متحركة خطيرة. ابتعد عن شفرات المروحة المتحركة. من الممكن أن المراوح لا تزال تدور عند إزالة كتلة المروحة من الهيكل يجب إبقاء الأصابع ومفكات البراغي وغيرها من الأشياء بعيدا عن الفتحات في كتلة المروحة.

**경고!**

움직이는 위험한 부품. 회전하는 송풍 날개에 접근하지 마세요. 새시로부터 팬 조립품을 제거할 때 팬은 여전히 회전하고 있을 수 있습니다. 팬 조립품 외관의 열려있는 부분들로부터 손가락 및 스크류드라이버, 다른 물체들이 가까이 하지 않도록 배치해 주십시오.

**Waarschuwing**

Gevaarlijk bewegende onderdelen. Houd voldoende afstand tot de bewegende ventilatorbladen. Het is mogelijk dat de ventilator nog draait tijdens het verwijderen van het ventilatorsamenstel uit het chassis. Houd uw vingers, schroevendraaiers en eventuele andere voorwerpen uit de buurt van de openingen in de ventilatorbehuizing.

## Power Cable and AC Adapter



**Warning!** When installing the product, use the provided or designated connection cables, power cables and AC adaptors. Using any other cables and adaptors could cause a malfunction or a fire. Electrical Appliance and Material Safety Law prohibits the use of UL or CSA -certified cables (that have UL/CSA shown on the cord) for any other electrical devices than products designated by Supermicro only.

### 電源コードとACアダプター

製品を設置する場合、提供または指定および購入された接続ケーブル、電源コードとACアダプターを該当する地域の条例や安全基準に適合するコードサイズやプラグと共に使用下さい。他のケーブルやアダプタを使用すると故障や火災の原因になることがあります。

電気用品安全法は、ULまたはCSA認定のケーブル(UL/CSAマークがコードに表記)を Supermicro が指定する製品以外に使用することを禁止しています。

### 警告

安装此产品时,请使用本身提供的或指定的或采购的连接线,电源线和电源适配器。包含遵照当地法规和安全要求的合规的电源线尺寸和插头。使用其它线材或适配器可能会引起故障或火灾。除了Supermicro所指定的产品,电气用品和材料安全法律规定禁止使用未经UL或CSA认证的线材。(线材上会显示UL/CSA符号)。

### 警告

安裝此產品時,請使用本身提供的或指定的或採購的連接線,電源線和電源適配器。包含遵照當地法規和安全要求的合規的電源線尺寸和插頭。使用其它線材或適配器可能會引起故障或火災。除了Supermicro所指定的產品,電氣用品和材料安全法律規定禁止使用未經UL或CSA認證的線材。(線材上會顯示UL/CSA符號)。

### Warnung

Nutzen Sie beim Installieren des Produkts ausschließlich die von uns zur Verfügung gestellten Verbindungskabeln, Stromkabeln und/oder Adapter, die Ihre örtlichen Sicherheitsstandards einhalten. Der Gebrauch von anderen Kabeln und Adapter können Fehlfunktionen oder Feuer verursachen. Die Richtlinien untersagen das Nutzen von UL oder CAS zertifizierten Kabeln (mit UL/CSA gekennzeichnet), an Geräten oder Produkten die nicht mit Supermicro gekennzeichnet sind.



### 전원 케이블 및 AC 어댑터

경고! 제품을 설치할 때 현지 코드 및 적절한 굵기의 코드와 플러그를 포함한 안전 요구 사항을 준수하여 제공되거나 지정된 연결 혹은 구매 케이블, 전원 케이블 및 AC 어댑터를 사용하십시오.

다른 케이블이나 어댑터를 사용하면 오작동이나 화재가 발생할 수 있습니다. 전기 용품 안전법은 UL 또는 CSA 인증 케이블 (코드에 UL / CSA가 표시된 케이블)을 Supermicro 가 지정한 제품 이외의 전기 장치에 사용하는 것을 금지합니다.

### Stroomkabel en AC-Adapter

Waarschuwing! Bij het aansluiten van het Product uitsluitend gebruik maken van de geleverde Kabels of een andere geschikte aan te schaffen Aansluitmethode, deze moet altijd voldoen aan de lokale voorschriften en veiligheidsnormen, inclusief de juiste kabeldikte en stekker. Het gebruik van niet geschikte Kabels en/of Adapters kan een storing of brand veroorzaken. Wetgeving voor Elektrische apparatuur en Materiaalveiligheid verbied het gebruik van UL of CSA -gecertificeerde Kabels (met UL/CSA in de code) voor elke andere toepassing dan de door Supermicro hiervoor beoogde Producten.

# Appendix B

## System Specifications

### Processors

Single AMD EPYC™ 8004 Series processor in Socket SP6 with up to 64 cores; CPU TDP supports up to 225 W  
 Note: Refer to the motherboard specifications pages on our website for updates to supported processors.

### Chipset

System on Chip

### BIOS

256Mb SPI AMI® BIOS; ACPI 6.0, Plug and Play (PnP), PCI firmware 4.0 support, BIOS rescue hot-key, SPI dual/quad speed support, RTC (Real Time Clock) wakeup, and SMBIOS 3.0 or later

### Memory

Up to 576 GB of registered ECC DDR5 up to 4800 MT/s SDRAM memory in six slots

### Storage Drives

Four hot-swap 3.5" drive bays support SATA (default)/NVMe\*/SAS\* drives

Two PCIe 3.0 x2 M.2 in 22110 or 2280 form factor

**\*Note:** Additional parts are required for NVMe and SAS drive support.

### PCI Expansion Slots

Two PCIe 5.0 x16 (FHFL)

One PCIe 5.0 x16 (LP)

### Input/Output

One dedicated IPMI LAN port

Two 10 GbE LAN ports via Broadcom (BCM57416)

Four USB 3.0 ports (rear)

One COM port

One VGA port

One TPM 2.0 header

### Motherboard

H13SVW-NT; 8.15" (L) x 13.05" (W), 20.32 cm (L) x 33.02 cm (W)

### Chassis

CSE-815BTS-R000WNP; 1U (WxHxD) 17.2" x 1.7" x 25.6" (436.9 x 43.2 x 650.2 mm)

### System Cooling

Six 40 x 40 x 56mm counter rotating PWM fans

One CPU heatsink

One air shroud

### Power Supply

Model: PWS-861A-1R, 860 W dual redundant modules, 80Plus Titanium level

AC Input

800 W: 100-127 Vac

860 W: 200-240 Vdc

860 W: 200-240 Vac +12V

Max: 66.67 A / Min: 0 A (100 Vac-127 Vac)

Max: 71.67 A / Min: 0 A (200 Vdc-240 Vdc)

Max: 71.67 A / Min: 0 A (200 Vac-240 Vac) 5V SB

Max: 4 A / Min: 0 A

(Full redundancy based on configuration and application load)

**Operating Environment**

Operating Temperature: 10° to 40° C (50° to 95° F)  
 Non-operating Temperature: -30° to 60° C (-22° to 140° F)  
 Operating Relative Humidity: 8% to 80% (non-condensing)  
 Non-operating Relative Humidity: 8% to 95% (non-condensing)  
 Operating Temperature based on configurations

**Regulatory Compliance**

FCC, ICES, CE, VCCI, RCM, UKCA, NRTL, CB

**Applied Directives, Standards**

EMC/EMI: 2014/30/EU (EMC Directive)  
 Electromagnetic Compatibility Regulations 2016  
 FCC Part 15 Subpart B  
 ICES-003  
 VCCI-CISPR 32  
 AS/NZS CISPR 32  
 BS/EN55032  
 BS/EN55035  
 CISPR 32  
 CISPR 35  
 BS/EN 61000-3-2  
 BS/EN 61000-3-3  
 BS/EN 61000-4-2  
 BS/EN 61000-4-3  
 BS/EN 61000-4-4  
 BS/EN 61000-4-5  
 BS/EN 61000-4-6  
 BS/EN 61000-4-8  
 BS/EN 61000-4-11

**Green Environment:**

2011/65/EU (RoHS Directive)  
 EC 1907/2006 (REACH)  
 2012/19/EU (WEEE Directive)  
 California Proposition 65

**Product Safety: 2014/35/EU (LVD Directive)**

Electrical Equipment (Safety) Regulations 2016  
 UL/CSA 62368-1 (USA and Canada)  
 BS/IEC/EN 62368-1

**Perchlorate Warning**

California Best Management Practices Regulations for Perchlorate Materials: This Perchlorate warning applies only to products containing CR (Manganese Dioxide) Lithium coin cells. "Perchlorate Material-special handling may apply. See [www.dtsc.ca.gov/hazardouswaste/perchlorate](http://www.dtsc.ca.gov/hazardouswaste/perchlorate)"

この装置は、クラスA機器です。この装置を住宅環境で使用すると電波妨害を引き起こすことがあります。この場合には使用者が適切な対策を講ずるよう要求されることがあります。

VCCI – A