

# SUPERO<sup>®</sup>

SUPERSERVER  
6017TR-TQF  
6017TR-TFF  
6017TR-TF

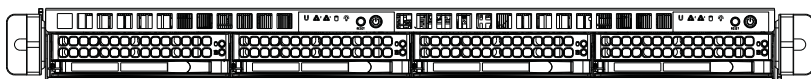

## User's Manual

Revision 1.0

The information in this User's Manual has been carefully reviewed and is believed to be accurate. The vendor assumes no responsibility for any inaccuracies that may be contained in this document, makes no commitment to update or to keep current the information in this manual, or to notify any person or organization of the updates. **Please Note: For the most up-to-date version of this manual, please see our web site at [www.supermicro.com](http://www.supermicro.com).**

Super Micro Computer, Inc. ("Supermicro") reserves the right to make changes to the product described in this manual at any time and without notice. This product, including software and documentation, is the property of Supermicro and/or its licensors, and is supplied only under a license. Any use or reproduction of this product is not allowed, except as expressly permitted by the terms of said license.

IN NO EVENT WILL SUPERMICRO BE LIABLE FOR DIRECT, INDIRECT, SPECIAL, INCIDENTAL, SPECULATIVE OR CONSEQUENTIAL DAMAGES ARISING FROM THE USE OR INABILITY TO USE THIS PRODUCT OR DOCUMENTATION, EVEN IF ADVISED OF THE POSSIBILITY OF SUCH DAMAGES. IN PARTICULAR, SUPERMICRO SHALL NOT HAVE LIABILITY FOR ANY HARDWARE, SOFTWARE, OR DATA STORED OR USED WITH THE PRODUCT, INCLUDING THE COSTS OF REPAIRING, REPLACING, INTEGRATING, INSTALLING OR RECOVERING SUCH HARDWARE, SOFTWARE, OR DATA.

Any disputes arising between manufacturer and customer shall be governed by the laws of Santa Clara County in the State of California, USA. The State of California, County of Santa Clara shall be the exclusive venue for the resolution of any such disputes. Super Micro's total liability for all claims will not exceed the price paid for the hardware product.

FCC Statement: This equipment has been tested and found to comply with the limits for a Class A digital device pursuant to Part 15 of the FCC Rules. These limits are designed to provide reasonable protection against harmful interference when the equipment is operated in a commercial environment. This equipment generates, uses, and can radiate radio frequency energy and, if not installed and used in accordance with the manufacturer's instruction manual, may cause harmful interference with radio communications. Operation of this equipment in a residential area is likely to cause harmful interference, in which case you will be required to correct the interference at your own expense.

California Best Management Practices Regulations for Perchlorate Materials: This Perchlorate warning applies only to products containing CR (Manganese Dioxide) Lithium coin cells. "Perchlorate Material-special handling may apply. See [www.dtsc.ca.gov/hazardouswaste/perchlorate](http://www.dtsc.ca.gov/hazardouswaste/perchlorate)"

**WARNING: Handling of lead solder materials used in this product may expose you to lead, a chemical known to the State of California to cause birth defects and other reproductive harm.**

Manual Revision 1.0

Release Date: November 29, 2012

Unless you request and receive written permission from Super Micro Computer, Inc., you may not copy any part of this document.

Information in this document is subject to change without notice. Other products and companies referred to herein are trademarks or registered trademarks of their respective companies or mark holders.

Copyright © 2012 by Super Micro Computer, Inc.

All rights reserved.

**Printed in the United States of America**

## Preface

### About This Manual

This manual is written for professional system integrators and PC technicians. It provides information for the installation and use of the SuperServer 6017TR-TQF/TFF/TF. Installation and maintenance should be performed by experienced technicians only.

The SuperServer 6017TR-TQF/TFF/TF is a high-end server based on the SC808BT-1K28B 1U rackmount chassis and the dual processor X9DRT-IBQF/IBFF/F serverboard. All models have an IPMI LAN port and two serverboard nodes with two hot-swap 3.5" SATA3 Hard Disk Drives (HDD) each per node.

Each of the various models of the SuperServer 6017TR-TQF/TFF/TF servers and their associated serverboards for each of their unique options are listed in the table below:

SUPERSERVER 6017TR-TQF/TFF/TF Model Variations			
Server Model	X9DRT Serverboard	InfiniBand QDR	InfiniBand FDR
6017TR-TQF	X9DRT-IBQF	YES	
6017TR-TFF	X9DRT-IBFF		YES
6017TR-TF	X9DRT-F		

### Manual Organization

#### Chapter 1: Introduction

The first chapter provides a checklist of the main components included with the server system and describes the main features of the X9DRT-IBQF/IBFF/F serverboard and the SC808BT-1K28B chassis.

#### Chapter 2: Server Installation

This chapter describes the steps necessary to install the SuperServer 6017TR-TQF/TFF/TF into a rack and check out the server configuration prior to powering up the system. If your server was ordered without processor and memory components, this chapter will refer you to the appropriate sections of the manual for their installation.

### **Chapter 3: System Interface**

Refer here for details on the system interface, which includes the functions and information provided by the control panel on the chassis as well as other LEDs located throughout the system.

### **Chapter 4: System Safety**

You should thoroughly familiarize yourself with this chapter for a general overview of safety precautions that should be followed when installing and servicing the SUPERSERVER 6017TR-TQF/TFF/TF.

### **Chapter 5: Advanced Serverboard Setup**

Chapter 5 provides detailed information on the X9DRT-IBQF/IBFF/F serverboard, including the locations and functions of connections, headers and jumpers. Refer to this chapter when adding or removing processors or main memory and when reconfiguring the serverboard.

### **Chapter 6: Advanced Chassis Setup**

Refer to Chapter 6 for detailed information on the SC808BT-1K28BP server chassis. You should follow the procedures given in this chapter when installing, removing or reconfiguring SATA or peripheral drives and when replacing system power supply units and cooling fans.

### **Chapter 7: BIOS**

The BIOS chapter includes an introduction to BIOS and provides detailed information on running the CMOS Setup Utility.

### **Appendix A: BIOS Error Beep Codes**

### **Appendix B: System Specifications**

## Notes

## Table of Contents

### **Chapter 1 Introduction**

1-1	Overview .....	1-1
1-2	Serverboard Features .....	1-2
	Processors .....	1-2
	Memory .....	1-2
	Serial ATA .....	1-2
	PCI Expansion Slots .....	1-2
	Onboard Controllers/Ports .....	1-3
	Graphics Controller .....	1-3
	InfiniBand .....	1-3
	Other Features .....	1-3
1-3	Server Chassis Features .....	1-4
	System Power .....	1-4
	SATA Subsystem .....	1-4
	Front Control Panel .....	1-4
	I/O Ports .....	1-4
	Cooling System .....	1-5
	Air Shrouds .....	1-5
	Mounting Rails .....	1-5
1-4	Advanced Power Management .....	1-5
	Intel® Intelligent Power Node Manager (NM) .....	1-5
	Manageability Engine (ME) .....	1-5
1-5	Contacting Supermicro .....	1-7
1-6	2U Twin?: System Notes .....	1-8
	Nodes .....	1-8
	System Power .....	1-8
	SATA Backplane/Drives .....	1-8

### **Chapter 2 Server Installation**

2-1	Overview .....	2-1
2-2	Unpacking the System .....	2-1
2-3	Preparing for Setup .....	2-1
2-4	Cautions! .....	2-2
	Choosing a Setup Location .....	2-2
	Rack Precautions .....	2-2
	Server Precautions .....	2-2

---

Rack Mounting Considerations .....	2-3
Ambient Operating Temperature .....	2-3
Reduced Airflow .....	2-3
Mechanical Loading .....	2-3
Circuit Overloading.....	2-3
Reliable Ground .....	2-3
2-5 Installing the System into a Rack .....	2-4
Identifying the Sections of the Rack Rails.....	2-4
Installing the Inner Rail Extension .....	2-5
Outer Rack Rails.....	2-6
2-6 Checking the Serverboard Setup.....	2-8
2-7 Checking the Drive Bay Setup.....	2-9
<b>Chapter 3 System Interface</b>	
3-1 Overview .....	3-1
3-2 Control Panel Button .....	3-2
3-3 Control Panel LEDs .....	3-2
3-4 Drive Carrier LEDs.....	3-3
SATA Drives .....	3-3
SAS Drives.....	3-4
<b>Chapter 4 Standardized Warning Statements for AC Systems</b>	
4-1 About Standardized Warning Statements.....	4-1
Warning Definition .....	4-1
Installation Instructions.....	4-4
Circuit Breaker .....	4-5
Power Disconnection Warning .....	4-6
Equipment Installation.....	4-8
Restricted Area.....	4-9
Battery Handling.....	4-10
Redundant Power Supplies .....	4-12
Backplane Voltage .....	4-13
Comply with Local and National Electrical Codes .....	4-14
Product Disposal .....	4-15
Hot Swap Fan Warning.....	4-16
Power Cable and AC Adapter .....	4-18
<b>Chapter 5 Advanced Serverboard Setup</b>	
5-1 Handling the Serverboard.....	5-1
Precautions .....	5-1
Unpacking .....	5-1

---

---

---

5-2	Connecting Cables.....	5-2
	Connecting Data Cables.....	5-2
5-3	Control Panel Connectors and I/O Ports.....	5-2
	Connecting the Control Panel.....	5-3
5-4	Processor and Heatsink Installation.....	5-4
	Installing a Passive CPU Heatsink.....	5-8
	Removing the Heatsink.....	5-9
5-5	Installing Memory.....	5-10
	Removing Memory Modules.....	5-10
	Memory Support.....	5-10
	Maximum Memory.....	5-10
	DIMM Module Population Configuration.....	5-12
5-6	Adding PCI Expansion Cards.....	5-14
5-7	Serverboard Details.....	5-15
5-8	Connector Definitions.....	5-18
5-9	Jumper Settings.....	5-25
	Explanation of Jumpers.....	5-25
5-10	Onboard Indicators.....	5-27
5-11	PCI-Express and Serial ATA Connections.....	5-28
5-12	Installing Drivers.....	5-29
	Supero Doctor III.....	5-30
5-13	Onboard Battery.....	5-32

## **Chapter 6 Advanced Chassis Setup**

6-1	Static-Sensitive Devices.....	6-1
	Precautions.....	6-1
	Unpacking.....	6-1
6-2	Control Panel.....	6-2
6-3	Chassis Cover.....	6-3
6-4	Air Shrouds.....	6-4
6-5	Checking the Airflow.....	6-4
6-6	System Fans.....	6-5
6-7	Installing and Removing Hard Drives.....	6-6
	Accessing the Drive Bays.....	6-6

---

---

6-8	Installing the Serverboard .....	6-9
	Permanent and Optional Standoffs .....	6-9
6-9	Expansion Slot Setup .....	6-11
6-10	Power Supply .....	6-13
	Power Supply Replacement .....	6-13

**Chapter 7 BIOS**

7-1	Introduction .....	7-1
	Starting BIOS Setup Utility .....	7-1
	How To Change the Configuration Data .....	7-1
	Starting the Setup Utility .....	7-2
7-2	Main Setup .....	7-2
7-3	Advanced Settings Menu .....	7-4
7-4	Event Logs .....	7-28
7-5	IPMI .....	7-30
7-6	Boot .....	7-32
7-7	Security .....	7-33
7-8	Save & Exit .....	7-34

**Appendix A BIOS Error Beep Codes****Appendix B System Specifications**

# Notes

# Chapter 1

## Introduction

### 1-1 Overview

The SuperServer 6017TR-TQF/TF/TF is a high-end server comprised of two main subsystems: the SC808BT-1K28BP 2U server chassis and the X9DRT-IBQF/IBFF/F dual processor serverboard in four hot-swap nodes. Please refer to our web site for information on operating systems that have been certified for use with the system ([www.supermicro.com](http://www.supermicro.com)).

In addition to the serverboard and chassis, various hardware components have been included with the SuperServer 6017TR-TQF/TF/TF server, as listed below:

- Heat Sinks
  - Two (2) 1U passive CPU heat sinks for rear CPU (SNK-P0047PW)
  - Two (2) 1U passive CPU heat sinks w/narrow ILM (SNK-P0047PS)
- Two (2) Plastic air shroud (MCP-310-80803-0B)
- Six (6) 40x56-mm 4-pin PWM cooling fans (FAN-0085L4)
- Two (2) Round 50-cm 16-to-16-pin ribbon front control cables (CBL-0087)
- SATA Backplane
  - One (1) SATA Backplane for four (4) 3.5" HDD (BPN-SAS-808-O-P)
  - Four (4) hot-swap 3.5" HDD trays (MCP-220-00075-0B)
  - One (1) Set of SATA 4-51/47/41/37-cm round S-RA cables (CBL-0201L)
  - Two (2) 4-pin 20-cm power cables, ST to RA (CBL-0212L)
- Two (2) Riser cards (RSC-R1U-E16R-O-P)
- One (1) Rail set (MCP-290-00042-0V)

**Note:** a complete list of safety warnings is provided on the Supermicro web site at [http://www.supermicro.com/about/policies/safety\\_information.cfm](http://www.supermicro.com/about/policies/safety_information.cfm)

## 1-2 Serverboard Features

At the heart of the SuperServer 6017TR-TQF/TFF/TF lies the X9DRT-IBQF/IBFF/F, a dual processor serverboard based on the Intel® C602 chipset and designed to provide maximum performance. Two of these serverboards can be mounted in the SC808BT-1K28BP chassis.

The sections below cover the main features of the X9DRT-IBQF/IBFF/F serverboard (see Figure 1-1 for a block diagram of the chipset).

### Processors

The X9DRT-IBQF/IBFF/F supports single or dual Intel® Xeon® E5-2600 series processors (Socket R LGA 2011). Please refer to the serverboard description pages on our web site for a complete listing of supported processors ([www.supermicro.com](http://www.supermicro.com)).

### Memory

The X9DRT-IBQF/IBFF/F has eight (8) DIMM slots supporting up to 256 GB of DDR3-1600/1333/1066/800 MHz speed RDIMM/LDIMM registered ECC or 64 GB of DDR3-1600/1333/1066/800 MHz speed LDIMM SDRAM in up to 512 MB, 1 GB, 2 GB, 4 GB, 8 GB, 16 GB or 32 GB sizes at 1.35V or 1.5V voltages. See Chapter 5 for details.

**Note:** Check the Supermicro website ([www.supermicro.com](http://www.supermicro.com)) for the latest memory support information.

### Serial ATA

A Serial ATA controller is integrated into the C602 to provide up to a six-port SATA subsystem, (two SATA 3 (6 Gb/s) and four SATA 2 (3 Gb/s), which is either RAID 0, 1 and 10 (SATA2) or RAID 0, 1, 5 and 10 (SATA3) supported. The SATA drives are hot-swappable units.

**Note:** The operating system you use must have RAID support to enable the hot-swap capability and RAID function of the SATA drives.

### PCI Expansion Slots

The SuperServer 6017TR-TQF/TFF/TF has for each node one (1) PCI Express 3.0 x16 slot available for use with a riser card.

## Onboard Controllers/Ports

One Fast UART 16550 serial port, one 9-pin RS-232 port and a Mellonox Connect-X3 InfiniBand (on 6017TR-TQF and 6017TR-TFF servers only) supporting a single QSFP connector are located on the serverboard. The color-coded I/O ports include one COM port, a VGA (monitor) port, two USB 2.0 ports (additional one internal USB Type-A connector is included on the serverboard), an IPMI dedicated LAN port and two Ethernet ports.

**Note:** For IPMI Configuration Instructions, please refer to the Embedded BMC Configuration User's Guide available @ <http://www.supermicro.com/support/manuals/>.

## Graphics Controller

The X9DRT-IBQF/IBFF/F features an integrated Matrox G200eW Video Controller.

## InfiniBand

The 6017TR-TQF server include a QDR (quad data rate) speed InfiniBand QSFP connector. The 6017TR-TFF server includes a FDR (fourteen data rate) speed InfiniBand QSFP connector. InfiniBand is a scalable serial communications link intended for connecting processors with high-speed peripherals.

## Other Features

Other onboard features that promote system health include onboard voltage monitors, a chassis intrusion header, auto-switching voltage regulators, chassis and CPU overheat sensors, virus protection, node manager software and BIOS rescue.

## 1-3 Server Chassis Features

The following is a general outline of the main features of the SC808 server chassis.

### System Power

Each SC808 chassis model includes a high-efficiency 80-plus Platinum certified power supply, rated at 1280 Watts plus one redundant backup power supply. In the unlikely event your power supply fails, replacement is simple and can be accomplished without tools.

### SATA Subsystem

The SC808 supports up to four (4) 3.5" hot-swap SATA drives in trays (two for each node). These drives are hot-swappable units and are connected to a backplane that provides power and control.

**Note:** The operating system you use must have RAID support to enable the hot-swap capability of the drives.

### Front Control Panel

SC808BT-1K28BP chassis includes four front panels on the handles of the chassis which control each of the systems. Each control panel on the SUPERSERVER 6017TR-TQF/TF/TF provides you with system monitoring and control for one server node. LEDs indicate system power, HDD activity, network activity, system overheat and power supply failure. A main power button and a system reset button are also included.

### I/O Ports

The SC808 is an proprietary form factor chassis designed to be used in a 1U rackmount configuration. The SC808 chassis provides a low-profile add-on card slot, a COM port, a VGA port, two USB 2.0 ports , one IPMI Ethernet port and two gigabit Ethernet ports per node.

## **Cooling System**

The SC808 chassis accepts six (6) 4-cm system fans powered from either backplane or the serverboards. If not powered from the backplane, the SC808BT-1K28BP model chassis powers three fans from each of the two serverboards, so that when one of the serverboard drawers is removed, the other serverboards will continue running its fans.

## **Air Shrouds**

The SC808 chassis includes two plastic air shrouds that direct the airflow where cooling is needed on each serverboard. Always use the air shroud included with your chassis on each serverboard.

## **Mounting Rails**

The SC808 includes a set of quick-release rails, and can be placed in a rack for secure storage and use. To setup your rack, follow the step-by-step instructions included in this manual.

# **1-4 Advanced Power Management**

## **Intel® Intelligent Power Node Manager (NM)**

The Intel® Intelligent Power Node Manager (IPNM) provides your system with real-time thermal control and power management for maximum energy efficiency. Although IPNM Specification Version 1.5 is supported by the BMC (Baseboard Management Controller), your system must also have IPNM-compatible Manageability Engine (ME) firmware installed to use this feature.

## **Manageability Engine (ME)**

The Manageability Engine, which is an ARC controller embedded in the IOH (I/O Hub), provides Server Platform Services (SPS) to your system. The services provided by SPS are different from those provided by the ME on client platforms.

**Figure 1-1. Intel C602 Chipset:  
System Block Diagram**

**Note:** This is a general block diagram and may not exactly represent the features on your serverboard. See the previous pages for the actual specifications of your serverboard. This block diagram is intended for your reference only.

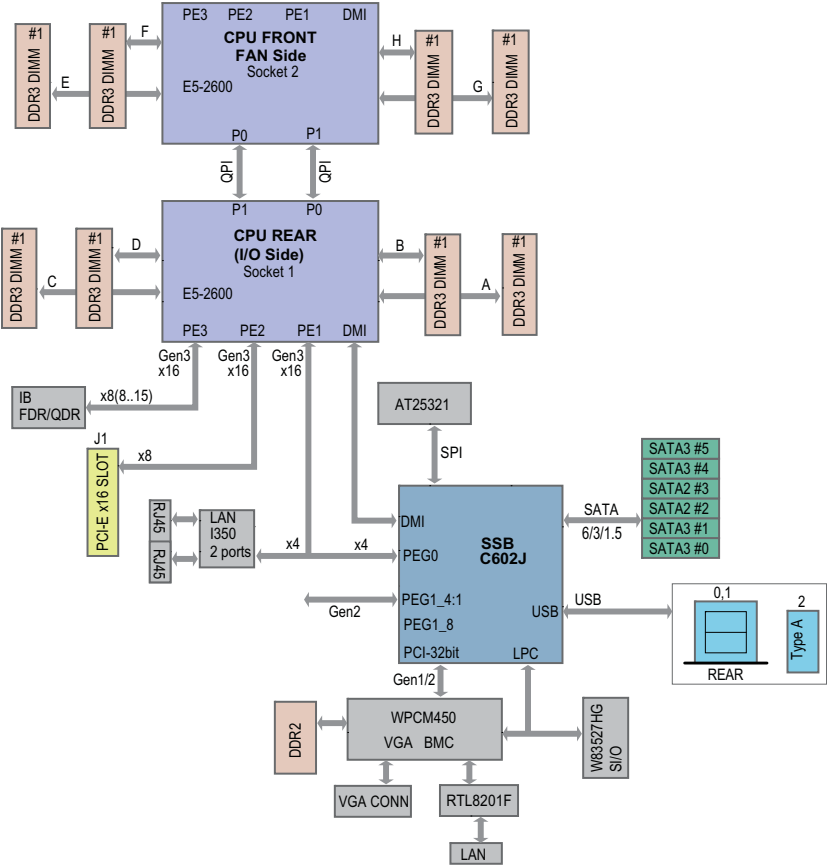

## 1-5 Contacting Supermicro

### Headquarters

Address: Super Micro Computer, Inc.  
980 Rock Ave.  
San Jose, CA 95131 U.S.A.

Tel: +1 (408) 503-8000

Fax: +1 (408) 503-8008

Email: [marketing@supermicro.com](mailto:marketing@supermicro.com) (General Information)  
[support@supermicro.com](mailto:support@supermicro.com) (Technical Support)

Web Site: [www.supermicro.com](http://www.supermicro.com)

### Europe

Address: Super Micro Computer B.V.  
Het Sterrenbeeld 28, 5215 ML  
's-Hertogenbosch, The Netherlands

Tel: +31 (0) 73-6400390

Fax: +31 (0) 73-6416525

Email: [sales@supermicro.nl](mailto:sales@supermicro.nl) (General Information)  
[support@supermicro.nl](mailto:support@supermicro.nl) (Technical Support)  
[rma@supermicro.nl](mailto:rma@supermicro.nl) (Customer Support)

### Asia-Pacific

Address: Super Micro Computer, Inc.  
4F, No. 232-1, Liancheng Rd  
New Taipei City 235  
Taiwan

Tel: +886-(2) 8226-3990

Fax: +886-(2) 8226-3991

Web Site: [www.supermicro.com.tw](http://www.supermicro.com.tw)

Technical Support:

Email: [support@supermicro.com.tw](mailto:support@supermicro.com.tw)

Tel: +886-(2)-8226-3990

## 1-6 2U Twin<sup>2</sup>: System Notes

As a 2U Twin<sup>2</sup> configuration, the SuperServer 6017TR-TQF/TFF/TF is a unique server system. With two system boards incorporated into a single chassis acting as two separate nodes, there are several points you should keep in mind.

### Nodes

Each of the two serverboards act as a separate node in the system. As independent nodes, each may be powered off and on without affecting the others. In addition, each node is a hot-swappable unit that may be removed from the rear of the chassis. The nodes are connected to the server backplane by means of an adapter card.

**Note:** A guide pin is located between the upper and lower nodes on the inner chassis wall. This guide pin also acts as a “stop” when a node is fully installed. If too much force is used when inserting a node this pin may break off. Take care to slowly slide a node in until you hear the “click” of the locking tab seating itself.

### System Power

Dual 1280 Watt power supplies are used to provide the power for all serverboards. Each serverboard however, can be shut down independently of the other with the power button on its own control panel.

### SATA Backplane/Drives

As a system, the SuperServer 6017TR-TQF/TFF/TF supports the use of twelve SATA drives. A single SATA backplane works to apply system-based control for power and fan speed functions, yet at the same time logically connects a set of two SATA drives to each serverboard. Consequently, RAID setup is limited to a two-drive scheme (RAID cannot be spread across all drives). See the Drive Bay Installation/Removal section in Chapter 6 for the logical hard drive and node configuration.

## Chapter 2

# Server Installation

### 2-1 Overview

This chapter provides a quick setup checklist to get your SuperServer 6017TR-TQF/TFF/TF up and running. Following these steps in the order given should enable you to have the system operational within a minimum amount of time. This quick setup assumes that your system has come to you with the processors and memory preinstalled. If your system is not already fully integrated with a serverboard, processors, system memory etc., please turn to the chapter or section noted in each step for details on installing specific components.

### 2-2 Unpacking the System

You should inspect the box the SuperServer 6017TR-TQF/TFF/TF was shipped in and note if it was damaged in any way. If the server itself shows damage you should file a damage claim with the carrier who delivered it.

Decide on a suitable location for the rack unit that will hold the SuperServer 6017TR-TQF/TFF/TF. It should be situated in a clean, dust-free area that is well ventilated. Avoid areas where heat, electrical noise and electromagnetic fields are generated. You will also need it placed near a grounded power outlet. Read the Rack and Server Precautions in the next section.

### 2-3 Preparing for Setup

The box the SuperServer 6017TR-TQF/TFF/TF was shipped in should include two sets of rail assemblies, two rail mounting brackets and the mounting screws you will need to install the system into the rack. Follow the steps in the order given to complete the installation process in a minimum amount of time. Please read this section in its entirety before you begin the installation procedure outlined in the sections that follow.

## 2-4 Cautions!

### Choosing a Setup Location

- Leave enough clearance in front of the rack to enable you to open the front door completely (~25 inches) and approximately 30 inches of clearance in the back of the rack to allow for sufficient airflow and ease in servicing.
- This product is for installation only in a Restricted Access Location (dedicated equipment rooms, service closets and the like).
- This product is not suitable for use with visual display work place devices according to §2 of the the German Ordinance for Work with Visual Display Units.

### Rack Precautions

- Ensure that the leveling jacks on the bottom of the rack are fully extended to the floor with the full weight of the rack resting on them.
- In single rack installation, stabilizers should be attached to the rack. In multiple rack installations, the racks should be coupled together.
- Always make sure the rack is stable before extending a component from the rack.
- You should extend only one component at a time - extending two or more simultaneously may cause the rack to become unstable.

### Server Precautions

- Review the electrical and general safety precautions in Chapter 4.
- Determine the placement of each component in the rack *before* you install the rails.
- Install the heaviest server components on the bottom of the rack first, and then work up.
- Use a regulating uninterruptible power supply (UPS) to protect the server from power surges, voltage spikes and to keep your system operating in case of a power failure.
- Allow any hot plug drives and power supply modules to cool before touching them.
- Always keep the rack's front door and all panels and components on the servers closed when not servicing to maintain proper cooling.

## Rack Mounting Considerations

### ***Ambient Operating Temperature***

If installed in a closed or multi-unit rack assembly, the ambient operating temperature of the rack environment may be greater than the ambient temperature of the room. Therefore, consideration should be given to installing the equipment in an environment compatible with the manufacturer's maximum rated ambient temperature (Tmra).

### ***Reduced Airflow***

Equipment should be mounted into a rack so that the amount of airflow required for safe operation is not compromised.

### ***Mechanical Loading***

Equipment should be mounted into a rack so that a hazardous condition does not arise due to uneven mechanical loading.

### ***Circuit Overloading***

Consideration should be given to the connection of the equipment to the power supply circuitry and the effect that any possible overloading of circuits might have on overcurrent protection and power supply wiring. Appropriate consideration of equipment nameplate ratings should be used when addressing this concern.

### ***Reliable Ground***

A reliable ground must be maintained at all times. To ensure this, the rack itself should be grounded. Particular attention should be given to power supply connections other than the direct connections to the branch circuit (i.e. the use of power strips, etc.).



**Warning!** To prevent bodily injury when mounting or servicing this unit in a rack, you must take special precautions to ensure that the system remains stable. The following guidelines are provided to ensure your safety:

- This unit should be mounted at the bottom of the rack if it is the only unit in the rack.
- When mounting this unit in a partially filled rack, load the rack from the bottom to the top with the heaviest component at the bottom of the rack.
- If the rack is provided with stabilizing devices, install the stabilizers before mounting or servicing the unit in the rack.

## 2-5 Installing the System into a Rack

This section provides information on installing the SC808 chassis into a rack unit with the rails provided. There are a variety of rack units on the market, which may mean the assembly procedure will differ slightly. You should also refer to the installation instructions that came with the rack unit you are using.

**NOTE:** This rail will fit a rack between 26" and 33.5" deep.

### Identifying the Sections of the Rack Rails

The chassis package includes two rack rail assemblies in the rack mounting kit. Each assembly consists of two sections: an inner fixed chassis rail that secures directly to the server chassis and an outer fixed rack rail that secures directly to the rack itself (Figure 2-1).

**Figure 2-1: Identifying the Sections of the Rack Rails  
(Right side rail shown)**

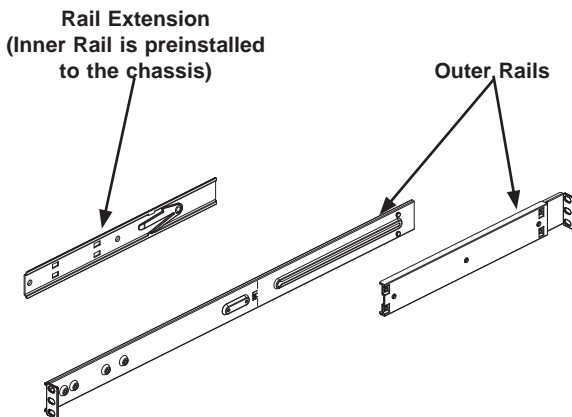

## Installing the Inner Rail Extension

The SC808 chassis includes a set of inner rails in two sections: Inner rails and inner rail extensions. The inner rails are preattached and do not interfere with normal use of the chassis if you decide not to use a server rack. Attach the inner rail extension to stabilize the chassis within the rack.

### ***Installing the Inner Rails (Figure 2-2)***

1. Place the inner rack extensions on the side of the chassis aligning the hooks of the chassis with the rail extension holes. Make sure the extension faces "outward" just like the preattached inner rail.
2. Slide the extension toward the front of the chassis.
3. Secure the chassis with two screws as illustrated.
4. Repeat steps 1-3 for the other inner rail extension.

**Figure 2-2: Installing the Inner Rail Extensions**

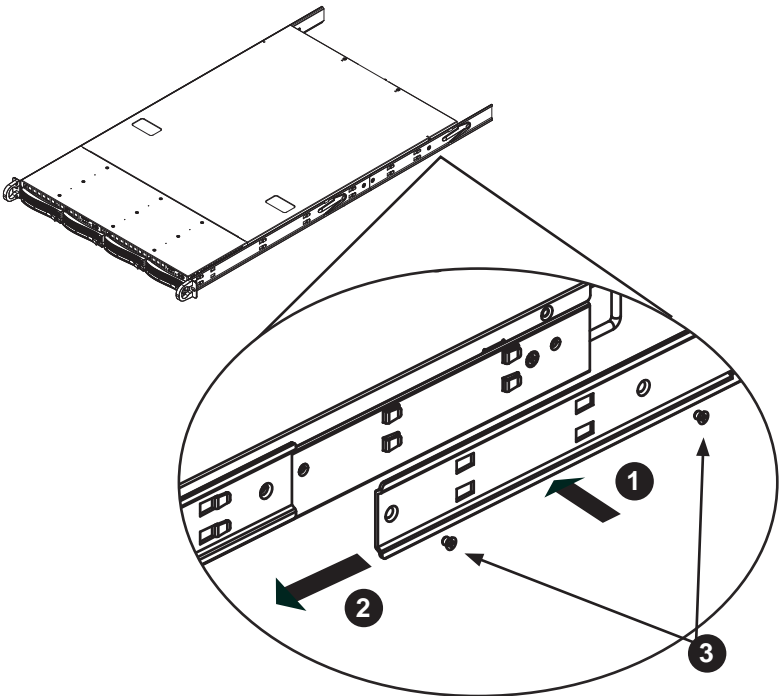

## Outer Rack Rails

Outer rails attach to the rack and hold the chassis in place.

### *Installing the Outer Rails to the Rack (Figure 2-3)*

1. Attach the short bracket to the outside of the long bracket. You must align the pins with the slides. Also, both bracket ends must face the same direction.
2. Adjust both the short and long brackets to the proper distance so that the rail fits snugly into the rack.
3. Secure the long bracket to the front side of the outer rail with two M5 screws and the short bracket to the rear side of the outer rail with three M5 screws.
4. Repeat steps 1-4 for the left outer rail.

**Figure 2-3. Assembling the Outer Rails**

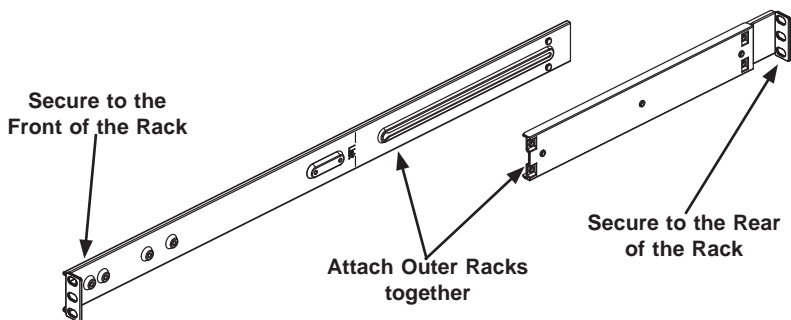

### *Installing the Chassis into a Rack (Figure 2-4)*

1. Confirm that chassis includes the inner rails (A) and rail extensions (B). Also, confirm that the outer rails (C) are installed on the rack.
2. Line chassis rails (A and B) with the front of the rack rails (C).
3. Slide the chassis rails into the rack rails, keeping the pressure even on both sides (you may have to depress the locking tabs when inserting). When the server has been pushed completely into the rack, you should hear the locking tabs "click".
4. (Optional) Insert and tightening the thumbscrews that hold the front of the server to the rack.



**Stability hazard.** The rack stabilizing mechanism must be in place, or the rack must be bolted to the floor before you slide the unit out for servicing. Failure to stabilize the rack can cause the rack to tip over.

**Figure 2-4: Installing the Rack Rails**

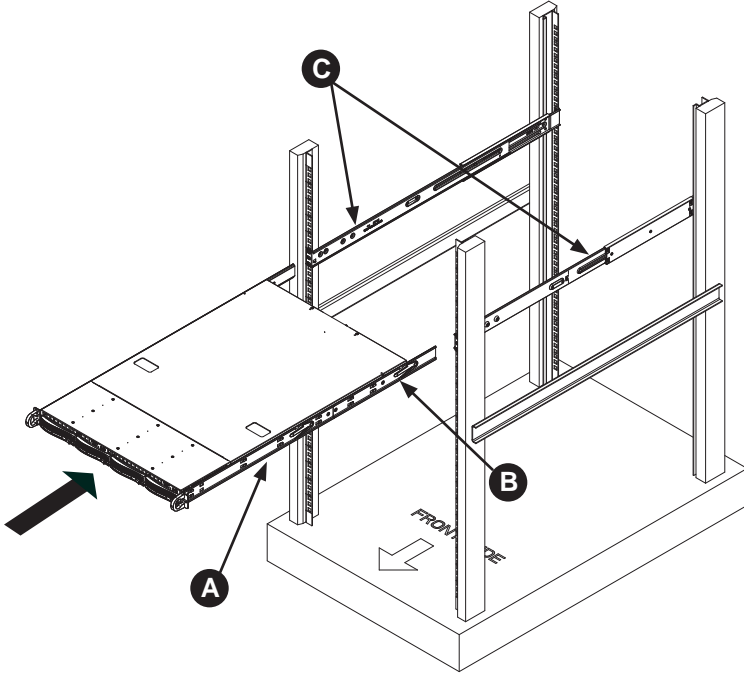

**Note:** The figure above is for illustration purposes only. Always install servers to the bottom of the rack first.

## 2-6 Checking the Serverboard Setup

After you install the SuperServer 6017TR-TQF/TFF/TF in the rack, you will need to open the unit to make sure the serverboard is properly installed and all the connections have been made.

### *Accessing the inside of the System*

Before operating the server for the first time, it is important to remove the protective film covering the top of the chassis, in order to allow for proper ventilation and cooling.

### *Removing the Chassis Cover and Protective Film (Figure 2-5)*

1. Disconnect the chassis from any power source and remove all four screws.
2. Gently push down on the chassis cover in the areas indicated in the illustration.
3. Push the cover toward the rear of the chassis and lift the cover upwards and off the chassis.
4. Peel off the protective film covering the top cover and the top of the chassis.
5. Check that all ventilation openings on the top cover and the top of the chassis are clear and unobstructed.

Figure 2-5. Accessing the Inside of the System

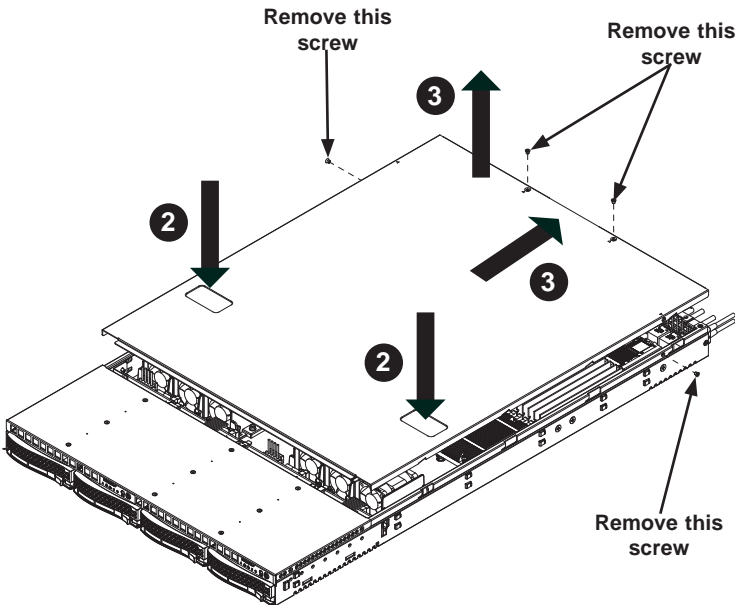

**Checking the Components and Setup**

1. You may have one or two processors already installed into the serverboard. Each processor needs its own heat sink. See Chapter 5 for instructions on processor and heat sink installation.
2. Your SuperServer 6017TR-TQF/TFF/TF server system may have come with system memory already installed. Make sure all DIMMs are fully seated in their slots. For details on adding system memory, refer to Chapter 5.
3. If desired, you can install add-on cards to the system. See Chapter 5 for details on installing PCI add-on cards.
4. Make sure all power and data cables are properly connected and not blocking the chassis airflow. Also make sure that no cables are positioned in front of the fans. See Chapter 5 for details on cable connections.

**2-7 Checking the Drive Bay Setup**

Next, you should check to make sure the peripheral drives and the SATA drives have been properly installed and all connections have been made.

**Checking the Drives**

1. All drives are accessible from the front of the server. A hard drive can be installed and removed from the front of the chassis without removing the top chassis cover.
2. Depending upon your system's configuration, your system may have one or more drives already installed. If you need to install hard drives, please refer to Chapter 6.

**Checking the Airflow**

1. Airflow is provided by six hot-swappable 4-cm chassis cooling fans in two housings. The system component layout was carefully designed to direct sufficient cooling airflow to the components that generate the most heat.
2. Note that all power and data cables have been routed in such a way that they do not block the airflow generated by the fans.

**Providing Power**

1. Plug the power cord(s) from the power supply unit(s) into a high-quality power strip that offers protection from electrical noise and power surges. It is recommended that you use an uninterruptible power supply (UPS).
2. Depress the power on button on the front of the chassis.

**Caution:** Except for short periods of time, do NOT operate the server without the cover in place. The chassis cover must be in place to allow proper airflow and prevent overheating.

# Chapter 3

## System Interface

### 3-1 Overview

There are several LEDs on the control panel and on the drive carriers to keep you constantly informed of the overall status of the system. SC808 models include four front panels on the handles of the chassis which control each of the systems. This chapter explains the meanings of all LED indicators and the appropriate response you may need to take.

Figure 3-1: Control Panel

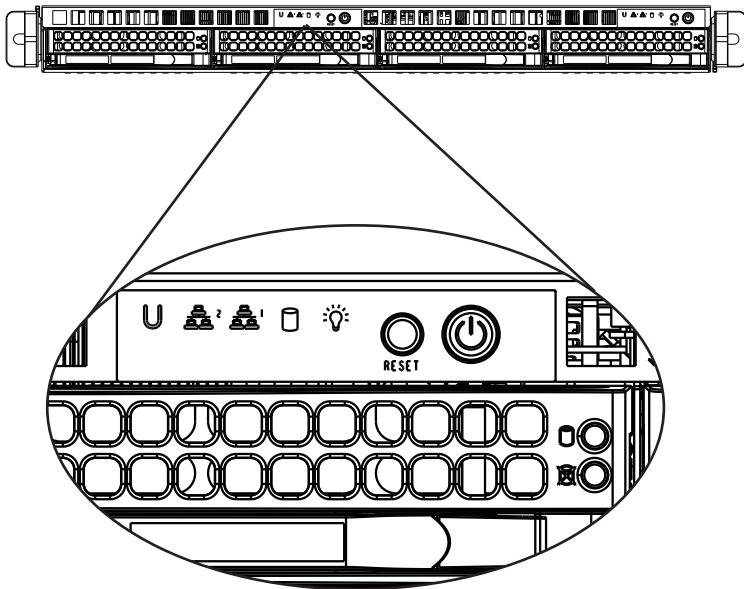

## 3-2 Control Panel Button

There are two push-buttons located on the front of the chassis. These are (in order from left to right) a reset button and a power on/off button.

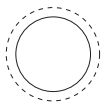

- **Reset:** The reset button is used to reboot the system.



- **Power:** The main power switch is used to apply or remove power from the power supply to the server system. Turning off system power with this button removes the main power but keeps standby power supplied to the system. Therefore, you must unplug system before servicing.

## 3-3 Control Panel LEDs

The control panel located on the front of the SC808 chassis has five LEDs. These LEDs provide you with critical information related to different parts of the system. This section explains what each LED indicates when illuminated and any corrective action you may need to take.



- **Universal Information LED:** The Universal Information LED is used to indicate fan failure, power failure, overheat condition, or to identify the unit within a large rack installation. The feature requires a serverboard that supports the Universal Information LED.

When this LED blinks red quickly, it indicates a fan failure and when blinking red slowly a power failure. This LED will be blue when used for UID (Unit Identifier). When on continuously red, it indicates an overheat condition, which may be caused by cables obstructing the airflow in the system or the ambient room temperature being too warm. See the table below for descriptions of the LED states



- NIC2: Indicates network activity on GLAN2 when flashing



- NIC1: Indicates network activity on GLAN1 when flashing



- HDD: Indicates IDE channel activity, SATA drive, and/or DVD-ROM drive activity when flashing.



- Power: Indicates power is being supplied to the system's power supply units. This LED should normally be illuminated when the system is operating.

### 3-4 Drive Carrier LEDs

The server chassis uses SATA drives.

#### SATA Drives

Each SATA drive carrier has two LEDs.

- Blue: Each Serial ATA drive carrier has a green LED. When illuminated, this green LED (on the front of the SATA drive carrier) indicates drive activity. A connection to the SATA backplane enables this LED to blink on and off when that particular drive is being accessed.
- Red: The red LED to indicate an SATA drive failure. If one of the SATA drives fail, you should be notified by your system management software.

## **SAS Drives**

This server system does not support SAS drives at this time.

## Chapter 4

# Standardized Warning Statements for AC Systems

### 4-1 About Standardized Warning Statements

The following statements are industry standard warnings, provided to warn the user of situations which have the potential for bodily injury. Should you have questions or experience difficulty, Contact Supermicro's Technical Support department for assistance. Only certified technicians should attempt to install or configure components.

Read this appendix in its entirety before installing or configuring components in the Supermicro chassis.

These warnings may also be found on our web site at [http://www.supermicro.com/about/policies/safety\\_information.cfm](http://www.supermicro.com/about/policies/safety_information.cfm).

### Warning Definition



#### Warning!

This warning symbol means danger. You are in a situation that could cause bodily injury. Before you work on any equipment, be aware of the hazards involved with electrical circuitry and be familiar with standard practices for preventing accidents.

#### 警告の定義

この警告サインは危険を意味します。

人身事故につながる可能性がありますので、いずれの機器でも動作させる前に、電気回路に含まれる危険性に注意して、標準的な事故防止策に精通して下さい。

此警告符号代表危险。

您正处于可能受到严重伤害的工作环境中。在您使用设备开始工作之前，必须充分意识到触电的危险，并熟练掌握防止事故发生的标准工作程序。请根据每项警告结尾的声明号码找到此设备的安全性警告说明的翻译文本。

Warnung

#### WICHTIGE SICHERHEITSHINWEISE

Dieses Warnsymbol bedeutet Gefahr. Sie befinden sich in einer Situation, die zu Verletzungen führen kann. Machen Sie sich vor der Arbeit mit Geräten mit den Gefahren elektrischer Schaltungen und den üblichen Verfahren zur Vorbeugung vor Unfällen vertraut. Suchen Sie mit der am Ende jeder Warnung angegebenen Anweisungsnummer nach der jeweiligen Übersetzung in den übersetzten Sicherheitshinweisen, die zusammen mit diesem Gerät ausgeliefert wurden.

BEWAHREN SIE DIESE HINWEISE GUT AUF.

#### INSTRUCCIONES IMPORTANTES DE SEGURIDAD

Este símbolo de aviso indica peligro. Existe riesgo para su integridad física. Antes de manipular cualquier equipo, considere los riesgos de la corriente eléctrica y familiarícese con los procedimientos estándar de prevención de accidentes. Al final de cada advertencia encontrará el número que le ayudará a encontrar el texto traducido en el apartado de traducciones que acompaña a este dispositivo.

GUARDE ESTAS INSTRUCCIONES

#### IMPORTANTES INFORMATIONS DE SÉCURITÉ

Ce symbole d'avertissement indique un danger. Vous vous trouvez dans une situation pouvant entraîner des blessures ou des dommages corporels. Avant de travailler sur un équipement, soyez conscient des dangers liés aux circuits électriques et familiarisez-vous avec les procédures couramment utilisées pour éviter les accidents. Pour prendre connaissance des traductions des avertissements figurant dans les consignes de sécurité traduites qui accompagnent cet appareil, référez-vous au numéro de l'instruction situé à la fin de chaque avertissement.

CONSERVEZ CES INFORMATIONS.

#### **תקנון הצהרות אזהרה**

הצהרות הבאות הן אזהרות על פי תקני התעשייה, על מנת להזהיר את המשתמש מפני חבלה פיזית אפשרית. במידה ויש שאלות או היתקלות בבעיה כלשהי, יש ליצור קשר עם מחלקת תמיכה טכנית של סופרמיקרו. טכנאים מוסמכים בלבד רשאים להתקין או להגדיר את הרכיבים.

יש לקרוא את הנספח במלואו לפני התקנת או הגדרת הרכיבים במארזי סופרמיקרו.

تحذير! هذا الرمز يعني خطر انك في حالة يمكن أن تتسبب في اصابة جسدية .  
قبل أن تعمل على أي معدات، كن على علم بالمخاطر الناجمة عن الدوائر  
الكهربائية  
وكن على دراية بالممارسات الوقائية لمنع وقوع أي حوادث  
استخدم رقم البيان المنصوص في نهاية كل تحذير للعثور ترجمتها

안전을 위한 주의사항

경고!

이 경고 기호는 위험이 있음을 알려 줍니다. 작업자의 신체에 부상을 야기 할 수 있는 상태에 있게 됩니다. 모든 장비에 대한 작업을 수행하기 전에 전기회로와 관련된 위험요소들을 확인하시고 사전에 사고를 방지할 수 있도록 표준 작업절차를 준수해 주시기 바랍니다.

해당 번역문을 찾기 위해 각 경고의 마지막 부분에 제공된 경고문 번호를 참조하십시오

#### BELANGRIJKE VEILIGHEIDSINSTRUCTIES

Dit waarschuwings symbool betekent gevaar. U verkeert in een situatie die lichamelijk letsel kan veroorzaken. Voordat u aan enige apparatuur gaat werken, dient u zich bewust te zijn van de bij een elektrische installatie betrokken risico's en dient u op de hoogte te zijn van de standaard procedures om ongelukken te voorkomen. Gebruik de nummers aan het eind van elke waarschuwing om deze te herleiden naar de desbetreffende locatie.

#### BEWAAR DEZE INSTRUCTIES

## Installation Instructions



### Warning!

Read the installation instructions before connecting the system to the power source.

設置手順書

システムを電源に接続する前に、設置手順書をお読み下さい。

警告

將系統與電源連接前，請先仔細閱讀安裝說明。

Warnung

Vor dem Anschließen des Systems an die Stromquelle die Installationsanweisungen lesen.

¡Advertencia!

Lea las instrucciones de instalación antes de conectar el sistema a la red de alimentación.

Attention

Avant de brancher le système sur la source d'alimentation, consulter les directives d'installation.

יש לקרוא את הוראות התקנה לפני חיבור המערכת למקור מתח.

اقر إرشادات التركيب قبل توصيل النظام إلى مصدر للطاقة

시스템을 전원에 연결하기 전에 설치 안내를 읽어주시십시오.

Waarschuwing

Raadpleeg de installatie-instructies voordat u het systeem op de voedingsbron aansluit.

## Circuit Breaker



### Warning!

This product relies on the building's installation for short-circuit (overcurrent) protection. Ensure that the protective device is rated not greater than: 250 V, 20 A.

サーキット・ブレーカー

この製品は、短絡(過電流)保護装置がある建物での設置を前提としています。

保護装置の定格が250 V、20 Aを超えないことを確認下さい。

### 警告

此產品的短絡(過載電流)保護由建築物的供電系統提供，確保短絡保護設備的額定電流不大於250 V, 20A。

### Warnung

Dieses Produkt ist darauf angewiesen, dass im Gebäude ein Kurzschluss- bzw. Überstromschutz installiert ist. Stellen Sie sicher, dass der Nennwert der Schutzvorrichtung nicht mehr als: 250 V, 20 A beträgt.

### ¡Advertencia!

Este equipo utiliza el sistema de protección contra cortocircuitos (o sobrecorrientes) del edificio. Asegúrese de que el dispositivo de protección no sea superior a: 250 V, 20 A.

### Attention

Pour ce qui est de la protection contre les courts-circuits (surtension), ce produit dépend de l'installation électrique du local. Vérifiez que le courant nominal du dispositif de protection n'est pas supérieur à :250 V, 20 A

מוצר זה מסתמך על הגנה המותקנת במבנים למניעת קצר חשמלי. יש לוודא כי המכשיר המגן מפני הקצר החשמלי הוא לא יותר מ-250 V, 20 A

هذا المنتج يعتمد على معدات الحماية من الدوائر القصيرة التي تم تثبيتها في المبنى

تأكد من أن تقييم الجهاز الوقائي ليس أكثر من: 20A, 250V

경고!

이 제품은 전원의 단락(과전류)방지에 대해서 전적으로 건물의 관련 설비에 의존합니다. 보호장치의 정격이 반드시 250V(볼트), 20A(암페어)를 초과하지 않도록 해야 합니다.

Waarschuwing

Dit product is afhankelijk van de kortsluitbeveiliging (overspanning) van uw elektrische installatie. Controleer of het beveiligde apparaat niet groter gedimensioneerd is dan 220V,20A.

## Power Disconnection Warning



### Warning!

The system must be disconnected from all sources of power and the power cord removed from the power supply module(s) before accessing the chassis interior to install or remove system components.

電源切斷の警告

システムコンポーネントの取り付けまたは取り外しのために、シャーシー内部にアクセスするには、

システムの電源はすべてのソースから切斷され、電源コードは電源モジュールから取り外す必要があります。

在你打开机箱并安装或移除内部器件前,必须将系统完全断电,并移除电源线.

Warnung

Das System muss von allen Quellen der Energie und vom Netzanschlusskabel getrennt sein, das von den Spg.Versorgungsteilmodulen entfernt wird, bevor es auf den Chassisinnenraum zurückgreift, um Systemsbestandteile anzubringen oder zu entfernen.

¡Advertencia!

El sistema debe ser disconnected de todas las fuentes de energía y del cable eléctrico quitado de los módulos de fuente de alimentación antes de tener acceso el interior del chasis para instalar o para quitar componentes de sistema.

Le système doit être débranché de toutes les sources de puissance ainsi que de son cordon d'alimentation secteur avant d'accéder à l'intérieur du châssis pour installer ou enlever des composants de système.

**אזהרה!**

יש לנתק את המערכת מכל מקורות החשמל ויש להסיר את כבל החשמלי מהספק לפני גישה לחלק הפנימי של המארז לצורך התקנת או הסרת רכיבים.

يجب فصل النظام من جميع مصادر الطاقة وإزالة سلك الكهرباء من وحدة امداد الطاقة قبل الوصول إلى المناطق الداخلية للهيكل لتثبيت أو إزالة مكونات الجهاز

경고!

시스템에 부품들을 장착하거나 제거하기 위해서는 새시 내부에 접근하기 전에 반드시 전원 공급장치로부터 연결되어있는 모든 전원과 전기코드를 분리해주어야 합니다.

Waarschuwing

Voordat u toegang neemt tot het binnenwerk van de behuizing voor het installeren of verwijderen van systeem onderdelen, dient u alle spanningsbronnen en alle stroomkabels aangesloten op de voeding(en) van de behuizing te verwijderen

## Equipment Installation



### Warning!

Only trained and qualified personnel should be allowed to install, replace, or service this equipment.

#### 機器の設置

トレーニングを受け認定された人だけがこの装置の設置、交換、またはサービスを許可されています。

### 警告

只有經過受訓且具資格人員才可安裝、更換與維修此設備。

#### Warnung

Das Installieren, Ersetzen oder Bedienen dieser Ausrüstung sollte nur geschultem, qualifiziertem Personal gestattet werden.

#### ¡Advertencia!

Solamente el personal calificado debe instalar, reemplazar o utilizar este equipo.

#### Attention

Il est vivement recommandé de confier l'installation, le remplacement et la maintenance de ces équipements à des personnels qualifiés et expérimentés.

#### אזהרה!

צוות מוסמך בלבד רשאי להתקין, להחליף את הציוד או לתת שירות עבור הציוד.

يجب أن يسمح فقط للموظفين المؤهلين والمدربين لتثبيت واستبدال أو خدمة هذا الجهاز

#### 경고!

훈련을 받고 공인된 기술자만이 이 장비의 설치, 교체 또는 서비스를 수행할 수 있습니다.

## Waarschuwing

Deze apparatuur mag alleen worden geïnstalleerd, vervangen of hersteld door geschoold en gekwalificeerd personeel.

## Restricted Area



### Warning!

This unit is intended for installation in restricted access areas. A restricted access area can be accessed only through the use of a special tool, lock and key, or other means of security. (This warning does not apply to workstations).

## アクセス制限区域

このユニットは、アクセス制限区域に設置されることを想定しています。

アクセス制限区域は、特別なツール、鍵と錠前、その他のセキュリティの手段を用いてのみ出入りが可能です。

## 警告

此装置僅限安裝於進出管制區域・進出管制區域係指僅能以特殊工具、鎖頭及鑰匙或其他安全方式才能進入的區域・

## Warnung

Diese Einheit ist zur Installation in Bereichen mit beschränktem Zutritt vorgesehen. Der Zutritt zu derartigen Bereichen ist nur mit einem Spezialwerkzeug, Schloss und Schlüssel oder einer sonstigen Sicherheitsvorkehrung möglich.

## ¡Advertencia!

Esta unidad ha sido diseñada para instalación en áreas de acceso restringido. Sólo puede obtenerse acceso a una de estas áreas mediante la utilización de una herramienta especial, cerradura con llave u otro medio de seguridad.

## Attention

Cet appareil doit être installée dans des zones d'accès réservés. L'accès à une zone d'accès réservé n'est possible qu'en utilisant un outil spécial, un mécanisme de verrouillage et une clé, ou tout autre moyen de sécurité.

## אזור עם גישה מוגבלת

### אזהרה!

יש להתקין את היחידה באזורים שיש בהם הגבלת גישה. הגישה ניתנת בעזרת כלי אבטחה בלבד (מפתח, מנעול וכד').

تم تخصيص هذه الوحدة لت تركيبها في مناطق محظورة .  
يمكن الوصول إلى منطقة محظورة فقط من خلال استخدام أداة خاصة،  
قفل ومفتاح أو أي وسيلة أخرى للالأمان

경고!

이 장치는 접근이 제한된 구역에 설치하도록 되어 있습니다. 특수 도구, 잠금 장치 및 키, 또는 기타 보안 수단을 통해서만 접근 제한 구역에 들어갈 수 있습니다.

### Waarschuwing

Dit apparaat is bedoeld voor installatie in gebieden met een beperkte toegang. Toegang tot dergelijke gebieden kunnen alleen verkregen worden door gebruik te maken van speciaal gereedschap, slot en sleutel of andere veiligheidsmaatregelen.

## Battery Handling



### Warning!

There is the danger of explosion if the battery is replaced incorrectly. Replace the battery only with the same or equivalent type recommended by the manufacturer. Dispose of used batteries according to the manufacturer's instructions

### 警告

電池更換不當會有爆炸危險。請使用製造商建議之相同或功能相當的電池更換原有電池。請按照製造商的說明指示處理廢棄舊電池。

### 電池の取り扱い

電池交換が正しく行われなかった場合、破裂の危険性があります。交換する電池はメーカーが推奨する型、または同等のものを使用下さい。使用済電池は製造元の指示に従って処分して下さい。

Warnung

Bei Einsetzen einer falschen Batterie besteht Explosionsgefahr. Ersetzen Sie die Batterie nur durch den gleichen oder vom Hersteller empfohlenen Batterietyp. Entsorgen Sie die benutzten Batterien nach den Anweisungen des Herstellers.

Attention

Danger d'explosion si la pile n'est pas remplacée correctement. Ne la remplacer que par une pile de type semblable ou équivalent, recommandée par le fabricant. Jeter les piles usagées conformément aux instructions du fabricant.

¡Advertencia!

Existe peligro de explosión si la batería se reemplaza de manera incorrecta. Reemplazar la batería exclusivamente con el mismo tipo o el equivalente recomendado por el fabricante. Desechar las baterías gastadas según las instrucciones del fabricante.

**אזהרה!**

קיימת סכנת פיצוץ של הסוללה במידה והוחלפה בדרך לא תקינה. יש להחליף את הסוללה בסוג התואם מחברת יצרן מומלצת.

סילוק הסוללות המשומשות יש לבצע לפי הוראות היצרן.

هناك خطر من انفجار في حالة استبدال البطارية بطريقة غير صحيحة فعليك استبدال البطارية فقط بنفس النوع أو ما يعادلها كما أوصت به الشركة المصنعة تخلص من البطاريات المستعملة وفقا لتعليمات الشركة الصانعة

경고!

배터리가 올바르게 교체되지 않으면 폭발의 위험이 있습니다. 기존 배터리와 동일하거나 제조사에서 권장하는 동등한 종류의 배터리로만 교체해야 합니다. 제조사의 안내에 따라 사용된 배터리를 처리하여 주십시오.

Waarschuwing

Er is ontploffingsgevaar indien de batterij verkeerd vervangen wordt. Vervang de batterij slechts met hetzelfde of een equivalent type die door de fabrikant aanbevolen wordt. Gebruikte batterijen dienen overeenkomstig fabrieksvoorschriften afgevoerd te worden.

## Redundant Power Supplies



### Warning!

This unit might have more than one power supply connection. All connections must be removed to de-energize the unit.

冗長電源装置

このユニットは複数の電源装置が接続されている場合があります。

ユニットの電源を切るためには、すべての接続を取り外さなければなりません。

### 警告

此裝置連接的電源可能不只一個。必須切斷所有電源才能停止對該裝置的供電。

Warnung

Dieses Gerät kann mehr als eine Stromzufuhr haben. Um sicherzustellen, dass der Einheit kein Strom zugeführt wird, müssen alle Verbindungen entfernt werden.

¡Advertencia!

Puede que esta unidad tenga más de una conexión para fuentes de alimentación. Para cortar por completo el suministro de energía, deben desconectarse todas las conexiones.

Attention

Cette unité peut avoir plus d'une connexion d'alimentation. Pour supprimer toute tension et tout courant électrique de l'unité, toutes les connexions d'alimentation doivent être débranchées.

**אם קיים יותר מספק אחד**

**אזהרה!**

ליחידה יש יותר מחיבור אחד של ספק. יש להסיר את כל החיבורים על מנת לרוקן את היחידה.

قد يكون لهذا الجهاز عدة اتصالات بوحدات امداد الطاقة.  
يجب إزالة كافة الاتصالات لعزل الوحدة عن الكهرباء

경고!

이 장치에는 한 개 이상의 전원 공급 단자가 연결되어 있을 수 있습니다. 이 장치에 전원을 차단하기 위해서는 모든 연결 단자를 제거해야만 합니다.

Waarschuwing

Deze eenheid kan meer dan één stroomtoevoeraansluiting bevatten. Alle aansluitingen dienen verwijderd te worden om het apparaat stroomloos te maken.

## Backplane Voltage



### Warning!

Hazardous voltage or energy is present on the backplane when the system is operating. Use caution when servicing.

バックプレーンの電圧

システムの稼働中は危険な電圧または電力が、バックプレーン上にかかっています。  
修理するにはご注意ください。

直流电源终端可能会产生危险的电压或能量。终端不使用时，请务必盖上机盖。机盖盖上后，请确保导体未绝缘部分无法使用。

Warnung

Wenn das System in Betrieb ist, treten auf der Rückwandplatine gefährliche Spannungen oder Energien auf. Vorsicht bei der Wartung.

¡Advertencia!

Cuando el sistema está en funcionamiento, el voltaje del plano trasero es peligroso. Tenga cuidado cuando lo revise.

Attention

Lorsque le système est en fonctionnement, des tensions électriques circulent sur le fond de panier. Prendre des précautions lors de la maintenance.

## מתח בפנל האחורי

אזהרה!  
קיימת סכנת מתח בפנל האחורי בזמן תפעול המערכת. יש להיזהר במהלך  
העבודה.

هناك خطر من التيار الكهربائي أو الطاقة الموجودة على اللوحة  
عندما يكون النظام يعمل كن حذرا عند خدمة هذا الجهاز

경고!

시스템이 동작 중일 때 후면판 (Backplane)에는 위험한 전압이나 에너지가 발생  
합니다. 서비스 작업 시 주의하십시오.

Waarschuwing

Een gevaarlijke spanning of energie is aanwezig op de backplane wanneer het  
systeem in gebruik is. Voorzichtigheid is geboden tijdens het onderhoud.

## Comply with Local and National Electrical Codes



### Warning!

Installation of the equipment must comply with local and national electrical codes.

地方および国の電気規格に準拠

機器の取り付けはその地方および国の電気規格に準拠する必要があります。

## 警告

設備安裝必須符合本地與本國電氣法規。

Warnung

Die Installation der Geräte muss den Sicherheitsstandards entsprechen.

¡Advertencia!

La instalación del equipo debe cumplir con las normas de electricidad locales y  
nacionales.

Attention

L'équipement doit être installé conformément aux normes électriques nationales et locales.

**תיאום חוקי החשמל הארצי**

**אזהרה!**

התקנת הציוד חייבת להיות תואמת לחוקי החשמל המקומיים והארציים.

تركيب المعدات الكهربائية يجب أن يمتثل للقوانين المحلية والوطنية المتعلقة بالكهرباء

경고!

현 지역 및 국가의 전기 규정에 따라 장비를 설치해야 합니다.

Waarschuwing

Bij installatie van de apparatuur moet worden voldaan aan de lokale en nationale elektriciteitsvoorschriften.

**Product Disposal**



**Warning!**

Ultimate disposal of this product should be handled according to all national laws and regulations.

製品の廃棄

この製品を廃棄処分する場合、国の関係する全ての法律・条例に従い処理する必要があります。

**警告**

本產品廢棄處理應依照所有國家法律規定進行。

### Warnung

Die Entsorgung dieses Produkts sollte gemäß allen Bestimmungen und Gesetzen des Landes erfolgen.

### ¡Advertencia!

Al deshacerse por completo de este producto debe seguir todas las leyes y reglamentos nacionales.

### Attention

La mise au rebut ou le recyclage de ce produit sont généralement soumis à des lois et/ou directives de respect de l'environnement. Renseignez-vous auprès de l'organisme compétent.

## סילוק המוצר

אזהרה!

סילוק סופי של מוצר זה חייב להיות בהתאם להנחיות וחוקי המדינה.

عند التخلص النهائي من هذا المنتج ينبغي التعامل معه وفقا لجميع القوانين واللوائح الوطنية

### Waarschuwing

De uiteindelijke verwijdering van dit product dient te geschieden in overeenstemming met alle nationale wetten en reglementen.

## Hot Swap Fan Warning



### Warning!

The fans might still be turning when you remove the fan assembly from the chassis. Keep fingers, screwdrivers, and other objects away from the openings in the fan assembly's housing.

### ファン・ホットスワップの警告

シャーシから冷却ファン装置を取り外した際、ファンがまだ回転している可能性があります。ファンの開口部に、指、ドライバー、およびその他のものを近づけないで下さい。

## 警告

當您從機架移除風扇裝置，風扇可能仍在轉動。小心不要將手指、螺絲起子和其他物品太靠近風扇。

### Warnung

Die Lüfter drehen sich u. U. noch, wenn die Lüfterbaugruppe aus dem Chassis genommen wird. Halten Sie Finger, Schraubendreher und andere Gegenstände von den Öffnungen des Lüftergehäuses entfernt.

### ¡Advertencia!

Los ventiladores podran dar vuelta cuando usted quite el montaje del ventilador del chasis. Mantenga los dedos, los destornilladores y todos los objetos lejos de las aberturas del ventilador

### Attention

Il est possible que les ventilateurs soient toujours en rotation lorsque vous retirez le bloc ventilateur du châssis. Prenez garde à ce que doigts, tournevis et autres objets soient éloignés du logement du bloc ventilateur.

## אזהרה!

כאשר מסירים את חלקי המאוורר מהמארז, יתכן והמאווררים עדיין עובדים. יש להרחיק למרחק בטוח את האצבעות וכלי עבודה שונים מהפתחים בתוך המאוורר

من الممكن أن تزال المراوح لا تزال تدور عند إزالة كتلة المروحة من الهيكل يجب إبقاء الأصابع ومفكات البراغي وغيرها من الأشياء بعيدا عن الفتحات في كتلة المروحة.

### 경고!

새시로부터 팬 조립품을 제거할 때 팬은 여전히 회전하고 있을 수 있습니다. 팬 조립품 외관의 열려있는 부분들로부터 손가락 및 스크류드라이버, 다른 물체들이 가까이 하지 않도록 배치해 주십시오.

### Waarschuwing

Het is mogelijk dat de ventilator nog draait tijdens het verwijderen van het ventilatorsamenstel uit het chassis. Houd uw vingers, schroevendraaiers en eventuele andere voorwerpen uit de buurt van de openingen in de ventilatorbehuizing.

## Power Cable and AC Adapter



### Warning!

When installing the product, use the provided or designated connection cables, power cables and AC adaptors. Using any other cables and adaptors could cause a malfunction or a fire. Electrical Appliance and Material Safety Law prohibits the use of UL or CSA -certified cables (that have UL/CSA shown on the code) for any other electrical devices than products designated by Supermicro only.

### 電源コードとACアダプター

製品を設置する場合、提供または指定された接続ケーブル、電源コードとACアダプターを使用下さい。他のケーブルやアダプタを使用すると故障や火災の原因になることがあります。電気用品安全法は、ULまたはCSA認定のケーブル(UL/CSEマークがコードに表記)をSupermicroが指定する製品以外に使用することを禁止しています。

### 警告

安裝產品時，請使用隨附或指定的連接線、電線和AC變壓器。使用其他電線和變壓器可能會導致產品故障或發生火災。除了Supermicro所指定的產品，Electrical Appliance and Material Safety Law法律規定禁止任何其他電子裝置使用經過UL或CSA認證的電線(線纜上有UL或CSA的標示)。

### Warnung

Bei der Installation des Produkts, die zur Verfügung gestellten oder benannt Anschlusskabel, Stromkabel und Netzteile. Verwendung anderer Kabel und Adapter kann zu einer Fehlfunktion oder ein Brand entstehen. Elektrische Geräte und Material Safety Law verbietet die Verwendung von UL-oder CSA-zertifizierte Kabel, UL oder CSA auf der Code für alle anderen elektrischen Geräte als Produkte von Supermicro nur bezeichnet gezeigt haben.

### ¡Advertencia!

Al instalar el producto, utilice los cables de conexión previstos o designados, los cables y adaptadores de CA. La utilización de otros cables y adaptadores podría ocasionar un mal funcionamiento o un incendio. Aparatos Eléctricos y la Ley de Seguridad del Material prohíbe el uso de UL o CSA cables certificados que tienen UL o CSA se muestra en el código de otros dispositivos eléctricos que los productos designados por Supermicro solamente.

## Attention

Lors de l'installation du produit, utilisez les bables de connection fournis ou désigné. L'utilisation d'autres cables et adaptateurs peut provoquer un dysfonctionnement ou un incendie. Appareils électroménagers et de loi sur la sécurité Matériel interdit l'utilisation de UL ou CSA câbles certifiés qui ont UL ou CSA indiqué sur le code pour tous les autres appareils électriques que les produits désignés par Supermicro seulement.

## חשמליים ומתאמי AC

## אזהרה!

כאשר מתקינים את המוצר, יש להשתמש בכבלים, ספקים ומתאמים AC אשר נועדו וסופקו לשם כך. שימוש בכל כבל או מתאם אחר יכול לגרום לתקלה או קצר חשמלי. על פי חוקי שימוש במכשירי חשמל וחוקי בטיחות, קיים איסור להשתמש בכבלים המוסמכים ב- UL או ב- CSA (כשאר מופיע עליהם קוד של UL/CSA) עבור כל מוצר חשמלי אחר שלא צויין על ידי סופרמיקרו בלבד.

عند تركيب الجهاز يجب استخدام كابلات التوصيل، والكابلات الكهربائية ومحولات التيار المتردد التي . أن استخدام أي كابلات ومحولات أخرى يتسبب في حدوث عطل أو حريق. تم توفيرها لك مع المنتج الأجهزة الكهربائية ومواد قانون السلامة يحظر استخدام الكابلات UL أو CSA معتمدة من قبل لأي أجهزة كهربائية أخرى غير المنتجات المعينة من قبل Supermicro (التي تحمل علامة UL/CSA)

## 경고!

제품을 설치할 때에는 제공되거나 지정된 연결케이블과 전원케이블, AC어댑터를 사용해야 합니다. 그 밖의 다른 케이블들이나 어댑터들은 고장 또는 화재의 원인이 될 수 있습니다. 전기용품안전법 (Electrical Appliance and Material Safety Law)은 슈퍼마이크로에서 지정한 제품들 외에는 그 밖의 다른 전기 장치들을 위한 UL 또는 CSA에서 인증한 케이블 (전선 위에 UL/CSA가 표시)들의 사용을 금지합니다.

## Waarschuwing

Bij het installeren van het product, gebruik de meegeleverde of aangewezen kabels, stroomkabels en adapters. Het gebruik van andere kabels en adapters kan leiden tot een storing of een brand. Elektrisch apparaat en veiligheidsinformatiebladen wet verbiedt het gebruik van UL of CSA gecertificeerde kabels die UL of CSA die op de code voor andere elektrische apparaten dan de producten die door Supermicro alleen.

## Notes

## Chapter 5

### Advanced Serverboard Setup

This chapter covers the steps required to install the X9DRT-IBQF/IBFF/F serverboard into the chassis, connect the data and power cables and install add-on cards. All serverboard jumpers and connections are also described. A layout and quick reference chart are included in this chapter for your reference. Remember to completely close the chassis when you have finished working with the serverboard to better cool and protect the system.

#### 5-1 Handling the Serverboard

Electrostatic Discharge (ESD) can damage electronic components. To prevent damage to any printed circuit boards (PCBs), it is important to handle them very carefully (see previous chapter). To prevent the serverboard from bending, keep one hand under the center of the board to support it when handling. The following measures are generally sufficient to protect your equipment from electric static discharge.

##### Precautions

- Use a grounded wrist strap designed to prevent Electrostatic Discharge (ESD).
- Touch a grounded metal object before removing any board from its antistatic bag.
- Handle a board by its edges only; do not touch its components, peripheral chips, memory modules or gold contacts.
- When handling chips or modules, avoid touching their pins.
- Put the serverboard, add-on cards and peripherals back into their antistatic bags when not in use.
- For grounding purposes, make sure your computer chassis provides excellent conductivity between the power supply, the case, the mounting fasteners and the serverboard.

##### Unpacking

The serverboard is shipped in antistatic packaging to avoid electrical static discharge. When unpacking the board, make sure the person handling it is static protected.

## 5-2 Connecting Cables

Now that the processors are installed, the next step is to connect the cables to the serverboard.

### Connecting Data Cables

The cables used to transfer data from the peripheral devices have been carefully routed in preconfigured systems to prevent them from blocking the flow of cooling air that moves through the system from front to back. If you need to disconnect any of these cables, you should take care to reroute them as they were originally after reconnecting them (make sure the red wires connect to the pin 1 locations). If you are configuring the system, keep the airflow in mind when routing the cables.

The following cables need to be connected for the SuperServer 6017TR-TQF/TFF/TF system:

- Two round 50-cm 16-to-16-pin ribbon front control cables (CBL-0087)
- One set of SATA 4-51/47/41/37-cm round cables (CBL-0201L)
- Two 4-pin 20-cm power cables (CBL-0212L)

## 5-3 Control Panel Connectors and I/O Ports

The rear I/O ports are color coded in conformance with the PC 99 specification. See Figure 5-1 below for the colors and locations of the various I/O ports.

Figure 5-1. Rear I/O Ports

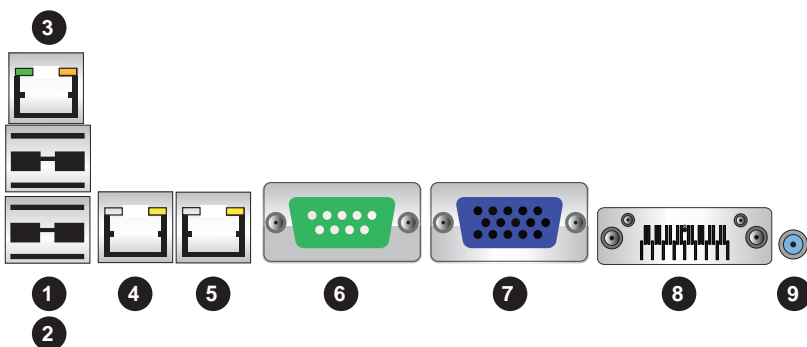

Back Panel I/O Port Locations and Definitions	
1.	Back Panel USB Port 0
2.	Back Panel USB Port 1
3.	IPMI_Dedicated LAN
4.	Gigabit LAN 1
5.	Gigabit LAN 2
6.	COM Port 1 (Turquoise)
7.	Back Panel VGA (Blue)
8.	InfiniBand Connector (For X9DRT-IBQF/X9DRT-IBFF)
9.	UID Switch

## Connecting the Control Panel

JF1 contains header pins for various front control panel connectors. See Figure 5-1 for the pin locations of the various front control panel buttons and LED indicators. Even and odd numbered pins are on opposite sides of each header.

All JF1 wires have been bundled into single keyed ribbon cable to simplify their connection. The red wire in the ribbon cable plugs into pin 1 of JF1. Connect the other end of the cable to the Control Panel printed circuit board, located just behind the system status LEDs in the chassis.

See the Connector Definitions section in this chapter for details and pin descriptions of JF1.

**Figure 5-2. Front Control Panel Header Pins (JF1)**

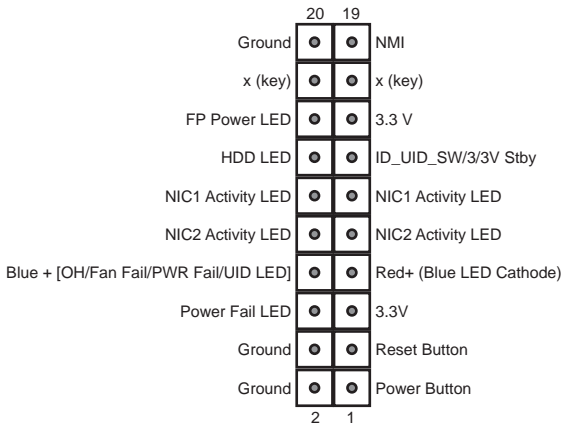

## 5-4 Processor and Heatsink Installation

**Caution!** When handling the processor package, avoid placing direct pressure on the label area.

**Note:** Always connect the power cord last, and always remove it before adding, removing or changing any hardware components. Make sure that you install the processor into the CPU socket before you install the CPU heatsink.

**Caution!** If you buy a CPU separately, make sure that you use an Intel-certified multi-directional heatsink only.

**Note:** Make sure to install the system board into the chassis before you install the CPU heatsink.

**Note:** When receiving a server board without a processor pre-installed, make sure that the plastic CPU socket cap is in place and none of the socket pins are bent; otherwise, contact your retailer immediately.

**Note:** Refer to the Supermicro website for updates on CPU support.

**Note:** When one CPU is installed, be sure to installed on CPU Socket 1 first.

### *Installing the LGA2011 Processor*

1. There are two load levers on the LGA2011 socket. To open the socket cover, first press and release the load lever labeled 'Open 1st'.

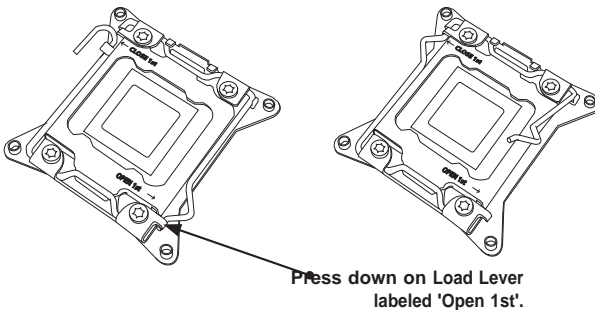

**Note:** Graphics and drawings shown in this manual are for illustration only. Your components may or may not look the same as the graphics shown in the manual.

2. Press the second load lever labeled 'Close 1st' to release the load plate that covers the CPU socket from its locking position.

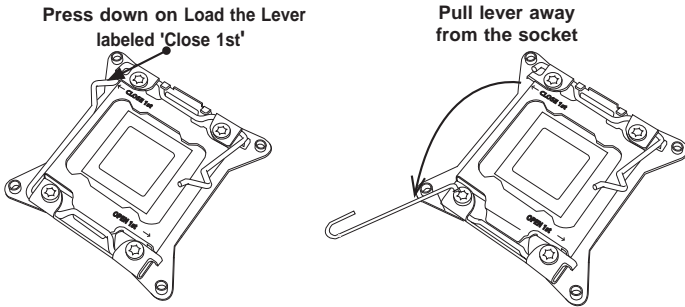

3. With the lever labeled 'Close 1st' fully retracted, gently push down on the 'Open 1st' lever to open the load plate. Lift the load plate to open it completely.

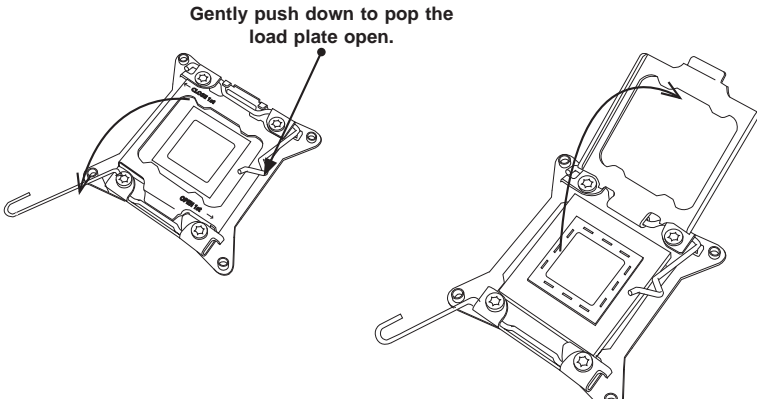

4. Using your thumb and the index finger, remove the 'WARNING' plastic cap from the socket.

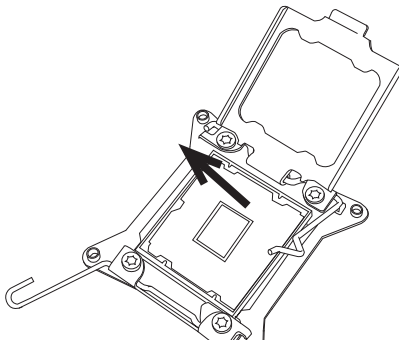

5. Use your thumb and index finger to hold the CPU on its edges. Align the CPU keys, which are semi-circle cutouts, against the socket keys.

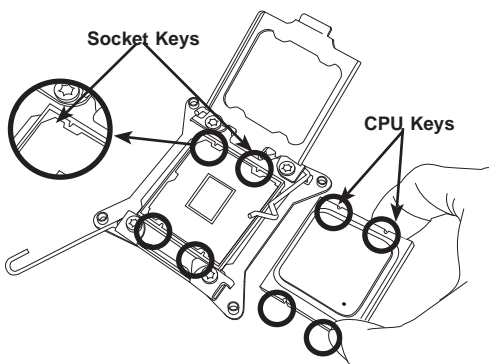

6. Once they are aligned, carefully lower the CPU straight down into the socket. (Do not drop the CPU on the socket. Do not move the CPU horizontally or vertically. Do not rub the CPU against the surface or against any pins of the socket to avoid damaging the CPU or the socket.)

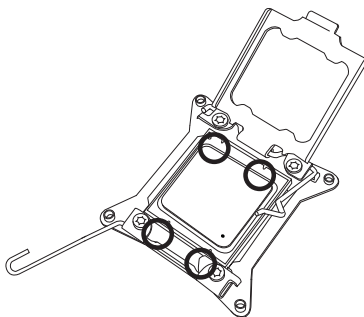

**Caution:** You can only install the CPU inside the socket in one direction. Make sure that it is properly inserted into the CPU socket before closing the load plate. If it doesn't close properly, do not force it as it may damage your CPU. Instead, open the load plate again and double-check that the CPU is aligned properly.

7. With the CPU inside the socket, inspect the four corners of the CPU to make sure that the CPU is properly installed.
8. Close the load plate with the CPU inside the socket. Lock the lever labeled 'Close 1st' first, then lock the lever labeled 'Open 1st' second. Use your thumb to gently push the load levers down to the lever locks.

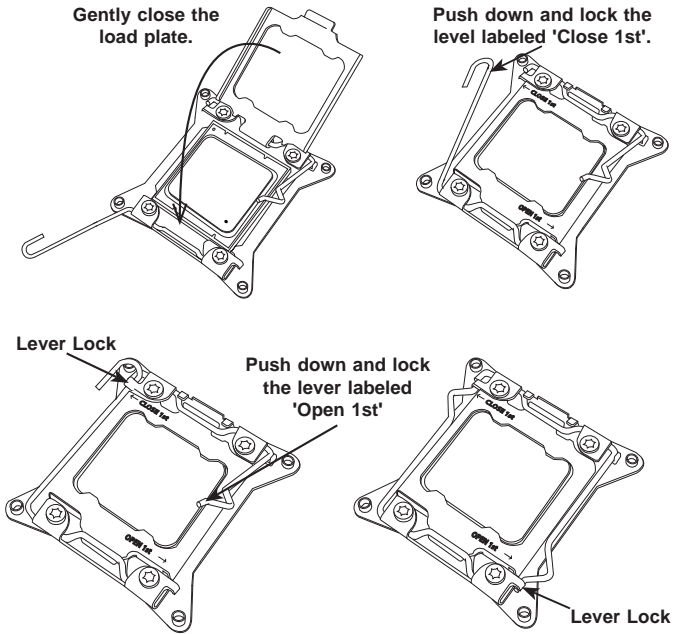

## Installing a Passive CPU Heatsink

1. Apply the proper amount of thermal grease to the heatsink.
2. Place the heatsink on top of the CPU so that the two mounting holes on the heatsink are aligned with those on the retention mechanism.
3. Install two screws on each side of the heatsink through the mounting holes on the serverboard, and turn the push-pins clockwise to lock them.

**Note:** Graphic drawings included in this manual are for reference only. They might look different from the components installed in your system.

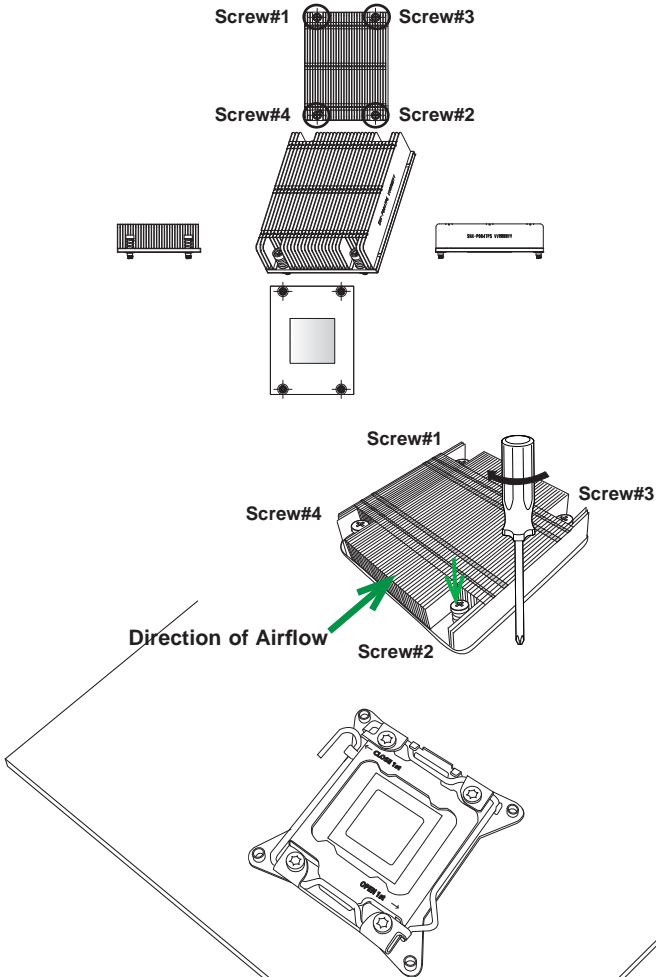

## Removing the Heatsink

**Caution:** We DO NOT recommend that the CPU or the heatsink be removed. However, if you do need to uninstall the heatsink, please follow the instructions below to uninstall the heatsink to prevent damage done to the CPU or the CPU socket.

1. Unplug the power cord from the power supply.
2. Press down the screw on the heatsink, and turn counter-clock-wise to loosen it. Repeat the same step to loosen the second screw.
3. Hold the heatsink as shown in the picture below, and gently wriggle the heatsink to loosen it. (Do not use excessive force when wriggling the heatsink.)
4. Once the heatsink is loosened, remove it from the serverboard.

**Note:** To reinstall the CPU and the heatsink, clean the surface of the CPU and the heatsink to get rid of the old thermal grease. Reapply the proper amount of thermal grease on the surface before reinstalling them on the serverboard.

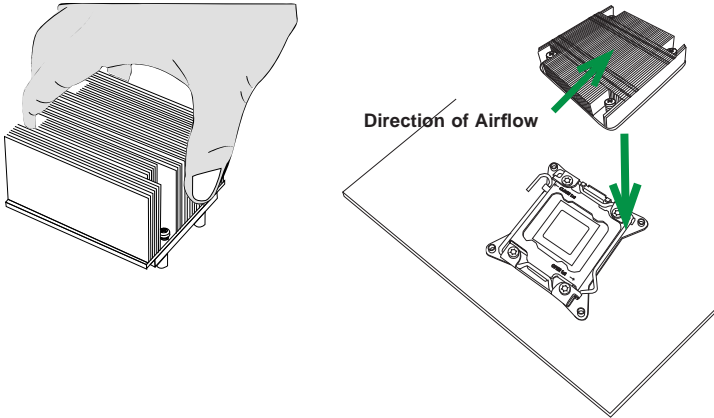

## 5-5 Installing Memory

**Caution:** exercise extreme care when installing or removing DIMM modules to prevent any possible damage.

### *Installing Memory*

1. Insert the desired number of DIMMs into the memory slots, starting with P1-DIMM #A1. Push the release tabs outwards on both ends of the DIMM slot to unlock it.
2. Align the key of the DIMM module with the receptive point on the memory slot.
3. Align the notches on both ends of the module against the receptive points on the ends of the slot.
4. Use two thumbs together to press the notches on both ends of the module straight down into the slot until the module snaps into place.
5. Press the release tabs to the locking positions to secure the DIMM module into the slot.

**Note:** 512 MB, 1 GB, 2 GB, 4 GB, 8 GB, 16 GB or 32 GB size memory modules are supported. It is highly recommended that you remove the power cord from the system before installing or changing memory modules. Please refer to our web site for memory that has been tested on the X9DRT-IBQF/IBFF/F serverboard.

### Removing Memory Modules

Press both notches on the ends of the DIMM module to unlock it. Once the DIMM module is loosened, remove it from the memory slot.

### Memory Support

The X9DRT-IBQF/IBFF/F serverboard supports DDR3-1600/1333/1066/800 MHz speed registered ECC/Unbuffered ECC/non-ECC SDRAM. Populating two slots at a time with memory modules of the same size and type will result in interleaved (128-bit) memory, which is faster than non-interleaved (64-bit) memory."

**Note:** Check the Supermicro website ([www.supermicro.com](http://www.supermicro.com)) for the latest memory support information.

### Maximum Memory

The X9DRT-IBQF/IBFF/F serverboard supports up to 256 GB of ECC 240-pin Registered (RDIMM)/Load Reduced (LRDIMM) ECC memory or up to 64 GB of Unbuffered (UDIMM) non-ECC memory in eight (8) DIMM slots.

Figure 5-3. Installing DIMM into Slot

**To Install:** Insert module vertically and press down until it snaps into place. Pay attention to the alignment notch at the bottom.

**To Remove:** Use your thumbs to gently push the release tabs near both ends of the module. This should release it from the slot.

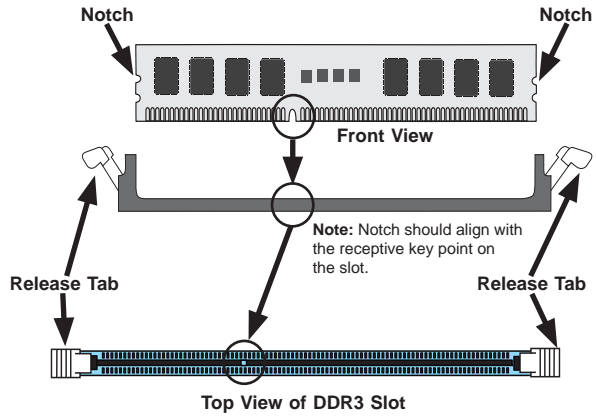

Processors and their Corresponding Memory Modules				
CPU#	Corresponding DIMM Modules			
<b>CPU1</b>	P1-DIMMA1	P1-DIMMB1	P1-DIMMC1	P1-DIMMD1
<b>CPU2</b>	P2-DIMME1	P2-DIMMF1	P2-DIMMG1	P2-DIMMH1

Processor and Memory Module Population	
Number of CPUs+DIMMs	CPU and Memory Population Configuration Table (*For memory to work proper, please install DIMMs in pairs)
<b>1 CPU &amp; 2 DIMMs</b>	CPU1 P1-DIMMA1/P1-DIMMB1
<b>1 CPU &amp; 4 DIMMs</b>	CPU1 P1-DIMMA1/P1-DIMMB1, P1-DIMMC1/P1-DIMMD1
<b>2 CPUs &amp; 4 DIMMs</b>	CPU1 + CPU2 P1-DIMMA1/P1-DIMMB1, P2-DIMME1/P2-DIMMF1
<b>2 CPUs &amp; 6 DIMMs</b>	CPU1 + CPU2 P1-DIMMA1/P1-DIMMB1/P1-DIMMC1/P1-DIMMD1, P2-DIMME1/P2-DIMMF1
<b>2 CPUs &amp; 8 DIMMs</b>	CPU1 + CPU2 P1-DIMMA1/P1-DIMMB1/P1-DIMMC1/P1-DIMMD1, P2-DIMME1/P2-DIMMF1/P2-DIMMG1/P2-DIMMH1

## DIMM Module Population Configuration

For memory to work properly, follow the tables below for memory installation:

### Installing UDIMM (ECC/Non-ECC) Memory

Intel E5-2600 Series Processor UDIMM Memory Support						
Ranks Per DIMM & Data Width	Memory Capacity Per DIMM  (See the Note below)			Speed (MT/s) and Voltage Validated by Slot per Channel (SPC) and DIMM Per Channel (DPC)		
				1 Slot Per Channel		
				1DPC		
				1.35V	1.5V	
SRx8 Non-ECC	1GB	2GB	4GB	NA	1066,1333, 1600	
DRx8 Non-ECC	2GB	4GB	8GB	NA	1066,1333, 1600	
SRx16 Non-ECC	512MB	1GB	2GB	NA	1066,1333, 1600	
SRx8 ECC	1GB	2GB	4GB	1066, 1333	1066,1333, 1600	
DRx8 ECC	2GB	4GB	8GB	1066, 1333	1066,1333, 1600	

**Note:** For detailed information on memory support and updates, please refer to the SMC Recommended Memory List posted on our website at <http://www.supermicro.com/support/resources/mem.cfm>.

### Installing RDIMM (ECC) Memory

Intel E5-2600 Series Processor RDIMM Memory Support						
Ranks Per DIMM & Data Width	Memory Capacity Per DIMM  (See the Note Below)			Speed (MT/s) and Voltage Validated by Slot per Channel (SPC) and DIMM Per Channel (DPC)		
				1 Slot Per Channel		
				1DPC		
				1.35V	1.5V	
SRx8	1GB	2GB	4GB	1066, 1333	1066, 1333,1600	
DRx8	2GB	4GB	8GB	1066, 1333	1066,1333, 1600	
SRx4	2GB	4GB	8GB	1066, 1333	1066,1333, 1600	
DRx4	4GB	8GB	16GB	1066, 1333	1066,1333, 1600	
QRx4	8GB	16GB	32GB	800	1066	
QRx8	4GB	8GB	16GB	800	1066	

**Note:** For detailed information on memory support and updates, please refer to the SMC Recommended Memory List posted on our website at <http://www.supermicro.com/support/resources/mem.cfm>.

## Installing LRDIMM (ECC) Memory

Intel E5-2600 Series Processor LRDIMM Memory Support				
Ranks Per DIMM & Data Width  (See the Note Below)	Memory Capacity Per DIMM		Speed (MT/s) and Voltage Validated by Slot per Channel (SPC) and DIMM Per Channel (DPC)	
			1 Slot Per Channel	
			1DPC	
			1.35V	1.5V
QRx4 (DDP)	16GB	32GB	1066,1333	1066,1333
QRx8 (P)	8GB	16GB	1066,1333	1066,1333
<b>Note:</b> For detailed information on memory support and updates, please refer to the SMC Recommended Memory List posted on our website at <a href="http://www.supermicro.com/support/resources/mem.cfm">http://www.supermicro.com/support/resources/mem.cfm</a> .				

**Note 1:** For the memory modules to work properly, please install DIMM modules of the same type, same speed and same operating frequency on the serverboard. Mixing of RDIMMs, UDIMMs or LRDIMMs is not allowed. Do not install both ECC and Non-ECC memory modules on the same serverboard.

**Note 2:** Using DDR3 DIMMs with different operating frequencies is not allowed.

Possible System Memory Allocation & Availability		
System Device	Size	Physical Memory Available (4 GB Total System Memory)
Firmware Hub flash memory (System BIOS)	1 MB	3.99 GB
Local APIC	4 KB	3.99 GB
Area Reserved for the chipset	2 MB	3.99 GB
I/O APIC (4 Kbytes)	4 KB	3.99 GB
PCI Enumeration Area 1	256 MB	3.76 GB
PCI Express (256 MB)	256 MB	3.51 GB
PCI Enumeration Area 2 (if needed) -Aligned on 256-M boundary-	512 MB	3.01 GB
VGA Memory	16 MB	2.85 GB
TSEG	1 MB	2.84 GB
Memory available for the OS & other applications		2.84 GB

## 5-6 Adding PCI Expansion Cards

The 6017TR-TQF/TF/TF includes one preinstalled riser card per node designed specifically for use in the SC808BT-1K28BP 1U rackmount chassis. These riser cards support one low-profile PCI Express x16 cards to fit inside the chassis for each node.

### ***Installing an Expansion Card***

1. After powering down the system, remove the PCI slot shield.
2. Fully seat the card into the slot, pushing down with your thumbs evenly on both sides of the card.
3. Finish by using a screw to secure the top of the card shield to the chassis. The PCI slot shield protects the serverboard and its components from EMI and aid in proper ventilation, so make sure it is always in place.

## 5-7 Serverboard Details

Figure 5-4. X9DRT-IBQF/IBFF/F Serverboard Layout  
(not drawn to scale)

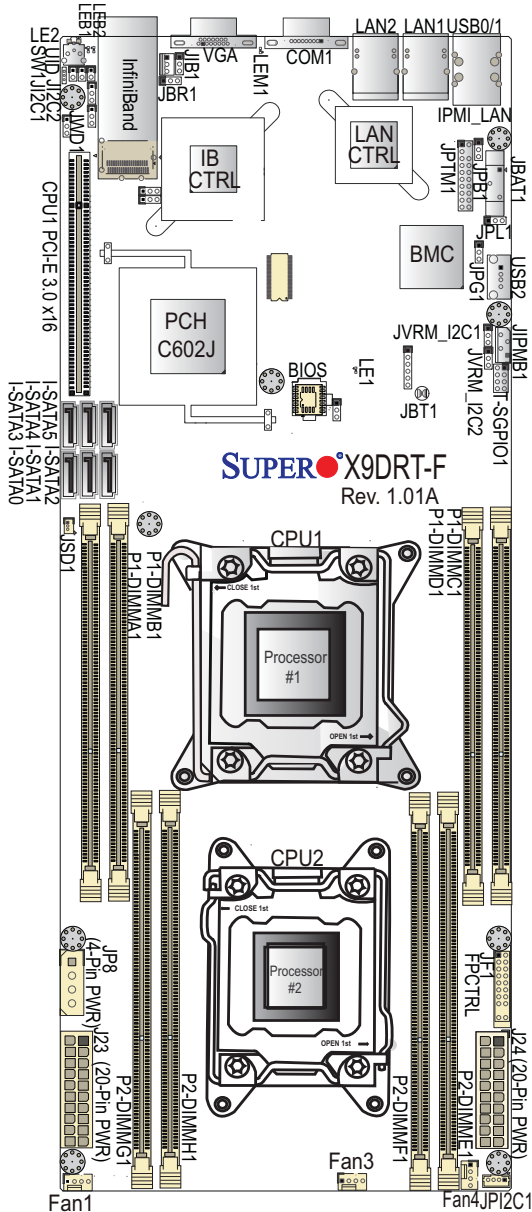

**Notes:**

1. For the latest CPU/Memory updates, please refer to our website at <http://www.supermicro.com/products/serverboard/> for details.
2. Use only the correct type of onboard CMOS battery as specified by the manufacturer. Do not install the onboard battery upside down to avoid possible explosion.
3. Jumpers not indicated are for test purposes only.
4. All graphics shown in this manual were based upon the latest PCB Revision available at the time of publishing of the manual. The serverboard you've received may or may not look exactly the same as the graphics shown in this manual.

**X9DRT-IBQF/IBFF/F Quick Reference**

<b>Jumper</b>	<b>Description</b>	<b>Default Setting</b>
JBT1	Clear CMOS	See page 5-25
JIB1	InfiniBand Enable/Disable (X9DRT-IBQF/X9DRT-IBFF only)	Pins 1-2 (Enabled)
J12C1/ J12C2	SMB to PCI-E Slots	Pins 2-3 (Normal)
JPB1	BMC Enable/Disable	Pins 1-2 (Enabled)
JPG1	VGA Enable/Disable	Pins 1-2 (Enabled)
JPL1	Ethernet GLAN1/GLAN2 Enable/Disable	Pins 1-2 (Enabled)
JWD1	Watch Dog	Pins 1-2 (Reset)

<b>LED</b>	<b>Description</b>	<b>State</b>	<b>Status</b>
LE1	Onboard PWR LED	Green: On	Onboard PWR On
LE2	UID LED	Blue: On	Unit Identified
LEB1/ LEB2	InfiniBand LED	On	IB Connected (X9DRT-IBQF and X9DRT-IBFF only)

LEM1	BMC Heartbeat LED	Green: Blinking	BMC Normal
------	-------------------	-----------------	------------

Connector	Description
IB	InfiniBand Connector (X9DRT-IBQF and X9DRT-IBFF only)
I-SATA 0/5	Intel PCH SATA Connectors 0-5 (SATA 3.0 Ports 0/1, SATA 2.0 Ports 2-5)
FAN 1, FAN 3/4	CPU/System Fan Headers (Fan1, Fan3, Fan4)
J23/J24	20-Pin Main Power Connectors
JBAT1	Onboard Battery (See the warning on P. 1-6.)
JF1	Front Panel Control Header
JIPMB1	4-pin External BMC I <sup>2</sup> C Header (for an IPMI Card)
JP8	4-Pin Auxiliary Power Connector
JPI <sup>2</sup> C1	Power Supply SMBbus I2C Header
JTPM1	TPM (Trusted Platform Module)/Port 80
JSD1	SATA DOM (Device_On_Module) Power Connector
LAN1/2	G-bit Ethernet Ports 1/2
(IPMI) LAN	IPMI_Dedicated LAN
Slot1	PCI-E 3.0 x16 Slot for SMC-Proprietary Riser Card (Available when CPU1 is installed)
T-SGPIO 1	Serial link General Purpose I/O Connection 1
UID SW	UID (Unit Identifier) Switch
USB 0/1	Back Panel USB 0/1
USB 2	Type-A Onboard USB 2.0 Connector
VGA	Backpanel VGA Port

**Note:** The X9DRT-F/-IBQF/-IBFF serverboard supports proprietary power connectors.

## 5-8 Connector Definitions

### Power Connectors

Two 20-pin main power supply connectors (J23/J24) and a 4-pin power connector (JP8) are located on the serverboard. These power connectors meet the SSI EPS 12V specification. For power supply to work properly, please follow the instructions given below. See the table on the right for pin definitions.

**Note 1:** You cannot use both 20-pin power connectors: PWR1 (the right connector) and PWR2 (the left connector) as input power supply at the same time. Only one connector can be used for input power supply to the serverboard at a time. For proper use of these proprietary PWR Connectors, please customize your PWR cables based on Supermicro PWR Connector Pin-Out Definitions listed above.

**Note 2:** The black square (dot) on a power connector indicates the location of Pin 1.

Pin#	Definition	Pin#	Definition
1	GND	11	PS_ON_N
2	GND	12	5V_STBY
3	GND	13	GND
4	GND	14	GND
5	GND	15	GND
6	NC	16	NC
7	12V	17	12V
8	12V	18	12V
9	12V	19	12V
10	12V	20	12V

### 4-pin Auxiliary Power Connector

In addition to two 20-pin power connectors, a 4-pin 12V PWR supply is located at JP8 on the serverboard. This power connector is used to provide power supply to hard drive disks. Refer to the layout below for the location.

**Note 1:** The 4-pin Auxiliary Power Connector is used for power supply output to HDDs only.

**Note 2:** The black square (dot) on the power connector indicates the location of Pin 1.

Pin#	Definition
1	+12V
2	Ground
3	Ground
4	+5V

### PW\_ON Connector

The Power Button connection is located on pins 1 and 2 of JF1. Momentarily contacting both pins will power on/off the system. This button can also be configured to function as a suspend button (with a setting in the BIOS - See Chapter 5). To turn off the power when the system is in suspend mode, press the button for 4 seconds or longer. Refer to the table on the right for pin definitions.

Power Button Pin Definitions (JF1)	
Pin#	Definition
1	PW_ON
2	Ground

### Reset Connector

The reset connector is located on pins 3 and 4 of JF1 and attaches to the reset switch on the computer chassis. See the table on the right for pin definitions.

Reset Button Pin Definitions (JF1)	
Pin#	Definition
3	Reset
4	Ground

### Power Fail LED

The Power Fail LED connection is located on pins 5 and 6 of JF1. Refer to the table on the right for pin definitions.

PWR Fail LED Pin Definitions (JF1)	
Pin#	Definition
5	3.3V
6	PWR Supply Fail

### Blue + [OH/Fan Fail/PWR Fail/UID LED]

Connect an LED cable to pins 7 and 8 of Front Control Panel to use the Overheat/Fan Fail/Power Fail and UID LED connections. The Red LED on pin 7 provides warnings of overheat, fan failure or power failure. The Blue LED on pin 8 works as the front panel UID LED indicator. The Red LED takes precedence over the Blue LED by default. Refer to the table on the right for pin definitions.

Blue + [OH/Fan Fail/PWR Fail/UID LED] Pin Definitions (JF1)	
Pin#	Definition
7	Red_LED-Cathode/OH/Fan Fail/Power Fail5.5V.SB
8	Blue_UID LED

OH/Fan Fail/PWR Fail LED Status (Red LED)	
State	Indication
Off	Normal
On	Overheat
Flashing	Fan Fail

**NIC1 (LAN1) LED**

The NIC (Network Interface Controller) LED connections for GLAN port 1 are located on pins 11 and 12 of JF1, and the LED connection for GLAN Port 2 are on Pins 9 and 10. Attach the NIC LED cables here to display network activity. Refer to the table on the right for pin definitions.

NIC1 LED Pin Definitions (JF1)	
Pin#	Definition
9	NIC 2 Activity LED
10	NIC 2 Link LED
11	NIC 1 Activity LED
12	NIC 1 Link LED

**HDD LED**

The HDD LED connection is located on pins 13 and 14 of JF1. Attach the hard drive LED cable here to display disk activity (for any hard drives on the system, including Serial ATA and IDE). See the table on the right for pin definitions

HDD LED Pin Definitions (JF1)	
Pin#	Definition
13	3.3V Standby
14	HD Active

**Power On LED**

The Power On LED connector is located on pins 15 and 16 of JF1. This connection is used to provide LED indication of power being supplied to the system. See the table on the right for pin definitions.

Power LED Pin Definitions (JF1)	
Pin#	Definition
15	3.3V
16	PWR LED

**NMI Button**

The non-maskable interrupt button header is located on pins 19 and 20 of JF1. Refer to the table on the right for pin definitions.

NMI Button Pin Definitions (JF1)	
Pin#	Definition
19	Control
20	Ground

**Video Connector**

A Video (VGA) connector is located next to the COM Port on the IO backplane. This connector is used to provide video and CRT display.

## Serial Ports

The COM1 serial port is located beside the VGA port. Refer to the serverboard layout for the location of the COM2 header. See the table on the right for pin definitions.

Serial Port Pin Definitions (COM1/COM2)			
Pin #	Definition	Pin #	Definition
1	DCD	6	DSR
2	RXD	7	RTS
3	TXD	8	CTS
4	DTR	9	RI
5	Ground	10	NC

NC indicates no connection.

## InfiniBand Connection

Both the X9DRT-IBQF and X9DRT-IBFF **serverboards** have an onboard InfiniBand (IB) connector, which is located on the rear IO panel on the serverboard. The IB switch is primarily used for High-performance computing. See the table on the right for pin definitions.

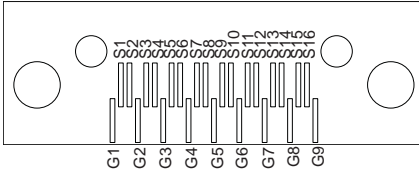

InfiniBand (IB) Pin Definitions			
Pin #	Definition	Pin #	Definition
S1	Input Pair0:Pos	S9	Output Pair3:Pos
S2	Input Pair0:Neg	S10	Output Pair3:Neg
S3	Input Pair1:Pos	S11	Output Pair2:Pos
S4	Input Pair1:Neg	S12	Output Pair2:Neg
S5	Input Pair2:Pos	S13	Output Pair1:Pos
S6	Input Pair2:Neg	S14	Output Pair1:Neg
S7	Input Pair3:Pos	S15	Output Pair0:Pos
S8	Input Pair3:Neg	S16	Output Pair0:Neg

### InfiniBand Ground Pins (G1–G9) Pin Definitions

Pin#	Definitions
G1–G9	Ground

## Fan Headers

This serverboard has three system/CPU fan headers (Fan 1, Fan 3, and Fan 4) on the serverboard. All these 4-pin fan headers are backward compatible with the traditional 3-pin fans. The fan speeds are controlled by firmware management via IPMI interface. See the table on the right for pin definitions.

### Fan Header (Fan1/3/4) Pin Definitions

Pin#	Definition
1	Ground
2	+12V
3	Tachometer
4	PWR Modulation

**IPMB I<sup>2</sup>C SMB**

A System Management Bus header for the IPMI slot is located at JIPMB1. Connect an appropriate cable here to use the IPMB I<sup>2</sup>C connection on your system.

SMB Header (JIPMB1) Pin Definitions	
Pin#	Definition
1	Data
2	Ground
3	Clock
4	No Connection

**Power SMB (I<sup>2</sup>C) Connector**

Power System Management Bus (I<sup>2</sup>C) Connector (JPI<sup>2</sup>C1) monitors power supply, fan and system temperatures. See the table on the right for pin definitions.

PWR SMB (JPI <sup>2</sup> C1) Pin Definitions	
Pin#	Definition
1	Clock
2	Data
3	PWR Fail
4	Ground
5	+3.3V

**TPM Header/Port 80**

A Trusted Platform Module/Port 80 header is located at JTPM1 to provide TPM support and Port 80 connection. Use this header to enhance system performance and data security. See the table on the right for pin definitions.

TPM/Port 80 Header (JTPM1) Pin Definitions			
Pin#	Definition	Pin#	Definition
1	LCLK	2	GND
3	LFRAME#	4	<(KEY)>
5	LRESET#	6	+5V (X)
7	LAD 3	8	LAD 2
9	+3.3V	10	LAD1
11	LAD0	12	GND
13	SMB_CLK4	14	SMB_DAT4
15	+3V_DUAL	16	SERIRQ
17	GND	18	CLKRUN# (X)
19	LPCPD#	20	LDRQ# (X)

**SATA DOM Power Connector**

A power connector for SATA DOM (Disk\_On\_Module) devices is located at JSD1. Connect an appropriate cable here to provide power support for your SATA DOM devices.

DOM PWR (JSD1) Pin Definitions	
Pin#	Definition
1	+5V
2	Ground
3	Ground

## Ethernet LAN Ports

Two Gigabit Ethernet ports (LAN1/2) are located on the I/O backplane on the serverboard. In addition, an IPMI Dedicated LAN is located above USB 0/1 ports on the backplane to provide KVM support for IPMI 2.0. All these ports accept RJ45 type cables.

**Note:** Please refer to the LED Indicator Section for LAN LED information.



LAN Ports (LAN1/2) Pin Definition			
Pin#	Definition	Pin#	Definition
1	P2V5SB	10	SGND
2	TD0+	11	Act LED
3	TD0-	12	P3V3SB
4	TD1+	13	Link 100 LED (Yellow, +3V3SB)
5	TD1-	14	Link 1000 LED (Yellow, +3V3SB)
6	TD2+	15	Ground
7	TD2-	16	Ground
8	TD3+	17	Ground
9	TD3-	18	Ground

NC indicates no connection.

## Universal Serial Bus (USB)

Two Universal Serial Bus ports (USB 0/1) are located on the I/O back panel. In addition, a Type USB 2.0 connector (USB 2), located next to the BMC chip, also provides onboard USB support (cables are not included). See the tables on the right for pin definitions.

Backplane USB (USB 0/1) Pin Definitions	
Pin#	Definition
1	+5V
2	PO-
3	PO+
4	Ground
5	NA

USB (2) Pin Definitions			
USB 2		USB 3	
Pin#	Definition	Pin#	Definition
1	+5V	1	+5V
2	PO-	2	PO-
3	PO+	3	PO+
4	Ground	4	Ground
5	NC	5	Key

NC indicates no connection.

## Unit Identifier Switches

Two Unit Identifier (UID) Switches and two LED Indicators are located on the serverboard. The Front Panel UID Switch is located at Pin 16 on JF2. The Rear UID Switch is located at SW1 next to the InfiniBand Connector. The Front Panel UID LED is located at Pin 17 of JF2, and the Rear UID LED is located at LE2. When the user presses a UID switch on the front panel or on the back panel, both Rear UID LED and Front Panel UID LED Indicators will be turned on. Press the UID switch again to turn off both LED Indicators. These UID Indicators provide easy identification of a system unit that may be in need of service. See the table on the right for pin definitions.

**Note:** UID LED is supported by the physical switch or the BMC. When it is controlled by the physical switch, it will stay solid. When it is controlled by the BMC, it will blink.

## T-SGPIO Header

A Serial Link General Purpose Input/Output header (T-SGPIO 1) is located on the serverboard to provide support for onboard SATA connections. See the table on the right for pin definitions.

UID Switch	
Pin#	Definition
1	Ground
2	Ground
3	Button In
4	Ground

UID Switches & LEDs	
Description	Location
FP Switch	Pin 16 on JF2
Rear Switch	SW1
FP UID LED (Blue LED)	Pin 17 on JF2
Rear UID LED	LE2

T-SGPIO Pin Definitions			
Pin#	Definition	Pin	Definition
1	NC	2	NC
3	Ground	4	Data
5	Load	6	Ground
7	Clock	8	NC

**Note:** NC= No Connection

## 5-9 Jumper Settings

### Explanation of Jumpers

To modify the operation of the serverboard, jumpers can be used to choose between optional settings. Jumpers create shorts between two pins to change the function of the connector. Pin 1 is identified with a square solder pad on the printed circuit board. See the diagram at right for an example of jumping pins 1 and 2. Refer to the serverboard layout page for jumper locations.

**Note:** On two-pin jumpers, "Closed" means the jumper is on and "Open" means the jumper is off the pins.

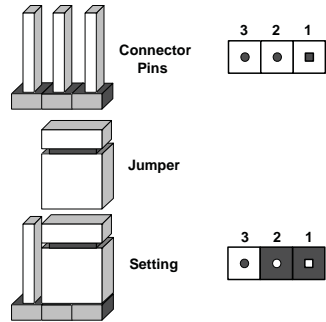

JBT1 contact pads

### CMOS Clear

JBT1 is used to clear CMOS, which will also clear any passwords. Instead of pins, this jumper consists of contact pads to prevent accidentally clearing the contents of CMOS.

#### To Clear CMOS

1. First power down the system and unplug the power cord(s). It is also recommended that you remove the onboard battery from the serverboard.
2. With the power disconnected, short the CMOS pads with a metal object such as a small screwdriver.
3. Remove the screwdriver (or shorting device).
4. Reconnect the power cord(s) and power on the system.

**Note:** Do not use the PW\_ON connector to clear CMOS.

### InfiniBand (IB) Enable

Both the X9DRT-IBQF and X9DRT-IBFF serverboards have Jumper JIB1, which allows you to enable the onboard InfiniBand connector. The default setting is 1-2 to enable the connection. See the table on the right for jumper settings.

InfiniBand Enable (JIB1) Jumper Settings	
Jumper Setting	Definition
1-2	Enabled (Default)
2-3	Disabled

### Watch Dog Enable/Disable

Watch Dog (JWD1) is a system monitor that can reboot the system when a software application hangs. Close Pins 1-2 to reset the system if an application hangs. Close Pins 2-3 to generate non-maskable interrupt signals for the application that hangs. See the table on the right for jumper settings. Watch Dog must also be enabled in the BIOS.

Watch Dog (JWD1) Jumper Settings	
Jumper Setting	Definition
Pins 1-2	Reset (default)
Pins 2-3	NMI
Open	Disabled

### VGA Enable

Jumper JPG1 allows the user to enable the onboard VGA connectors. The default setting is 1-2 to enable the connection. See the table on the right for jumper settings.

VGA Enable (JPG1) Jumper Settings	
Jumper Setting	Definition
1-2	Enabled (Default)
2-3	Disabled

### GLAN Enable/Disable

JPL1 enables or disables the GLAN 1/2 ports on the serverboard. See the table on the right for jumper settings. The default setting is Enabled.

GLAN Enable Jumper Settings	
Jumper Setting	Definition
1-2	Enabled (default)
2-3	Disabled

### BMC Enable

Jumper JPB1 allows you to enable the onboard BMC (Baseboard Management) Controller to provide IPMI 2.0/KVM support on the serverboard. See the table on the right for jumper settings.

BMC Enable (JPB1) Jumper Settings	
Jumper Setting	Definition
Pins 1-2	BMC Enable (Default)
Pins 2-3	Normal

### I2C Bus to PCI-Exp. Slots

Jumpers JI<sup>2</sup>C1 and JI<sup>2</sup>C2 allow you to connect the System Management Bus (I<sup>2</sup>C) to PCI-Express slots. The default setting is Open to disable the connection. See the table on the right for jumper settings.

I2C to PCI-E (JI <sup>2</sup> C1/JI <sup>2</sup> C2) Jumper Settings	
Jumper Setting	Definition
1-2	Enabled
2-3	Disabled (Default)

## 5-10 Onboard Indicators

### GLAN LEDs

The Gigabit LAN ports are located on the IO Backplane on the serverboard. On each Gb LAN port, one LED blinks to indicate activity while the other may be green, amber or off to indicate the speed of the connection. See the table on the right for the functions associated with the connection speed LED.

LAN LED (Connection Speed Indicator)	
LED Color	Definition
Off	10 MHz
Green	100 MHz
Amber	1 GHz

### IPMI Dedicated LAN LEDs

In addition to the Gigabit Ethernet ports, an IPMI Dedicated LAN is also located above the Backplane USB ports 0/1 on the serverboard. The amber LED on the right of the IPMI LAN port indicates activity, while the green LED on the left indicates the speed of the connection. See the table at right for more information.

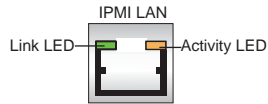

IPMI LAN Link LED (Left) & Activity LED (Right)		
Color	Status	Definition
Green: Solid	Link (Left)	100 Mb/s
Amber Blinking	Activity (Right)	Active

### Onboard Power LED

An Onboard Power LED is located at LE1 on the serverboard. When this LED is on, the system is on. Be sure to turn off the system and unplug the power cord before removing or installing components. See the tables at right for more information.

Onboard PWR LED Indicator (LE1) LED Settings	
LED Color	Status
Off	System Off (PWR cable not connected)
Green	System On
Green: Flashing Quickly	ACPI S1 State
Green: Flashing Slowly	ACPI S3 (STR) State

### Rear UID LED

The rear UID LED is located at LE2 on the rear of the serverboard. This LED is used in conjunction with the rear UID switch to provide easy identification of a system that might be in need of service.

UID LED (LE2) Status		
Color/State	OS	Status
Blue: On	Windows OS	Unit Identified
Blue: Blinking	Linux OS	Unit Identified

### InfiniBand LED Indicators

Both the X9DRT-IBQF and X9DRT-IBFF serverboards have two InfiniBand LED Indicators (LEB1/LEB2) that are located on the serverboard. The green LED (LEB1) is the InfiniBand Link LED. The yellow LED (LEB2) indicates activity. Refer to the table on the right for details.

InfiniBand Link LED (LEB1) Settings		
Color	Status	Definition
Green	Solid	InfiniBand Connected
Off	Off	No connection

InfiniBand Activity LED (LEB2) Settings		
Color	Status	Definition
Yellow	Solid	InfiniBand: Active
Yellow	Dim	InfiniBand: Connected, Activity: Idle
Off	Off	No connection

### BMC Heartbeat LED

A BMC Heartbeat LED is located at LEM1 on the serverboard. When LEM1 is blinking, BMC functions normally. See the table at right for more information.

BMC Heartbeat LED (LEM1) Status	
Color/State	Definition
Green: Blinking	BMC:Normal

## 5-11 PCI-Express and Serial ATA Connections

### PCI-Express 3.0 x16 Slot

A PCI-Express 3.0 x16 slot (Slot 1) is located on the serverboard.

### Serial ATA (SATA) Connections

A Front Panel Add-On Card header is located at JF2 on the serverboard. This header provides onboard SATA support. Plug an add-on card in JF2 to use SATA connections. In addition, two SATA connections (I-SATA 0/1), located next to the Intel PCH chip also provide SATA connections.

SATA Port Pin Definitions (I-SATA0-I-SATA5)	
Pin #	Definition
1	Ground
2	TXP
3	TXN
4	Ground
5	RXN
6	RXP
7	Ground

## 5-12 Installing Drivers

The CD that came bundled with the system contains drivers, some of which must be installed, such as the chipset driver. After inserting this CD into your CD-ROM drive, the display shown in Figure 5-6 should appear. (If this display does not appear, click on the My Computer icon and then on the icon representing your CD-ROM drive. Finally, double click on the S "Setup" icon.)

Click the icons showing a hand writing on paper to view the readme files for each item. Click the computer icons to the right of these items to install each item (from top to the bottom) one at a time. After installing each item, you should reboot the system before moving on to the next item on the list. The bottom icon with a CD on it allows you to view the entire contents of the CD.

Figure 5-6. Driver/Tool Installation Display Screen

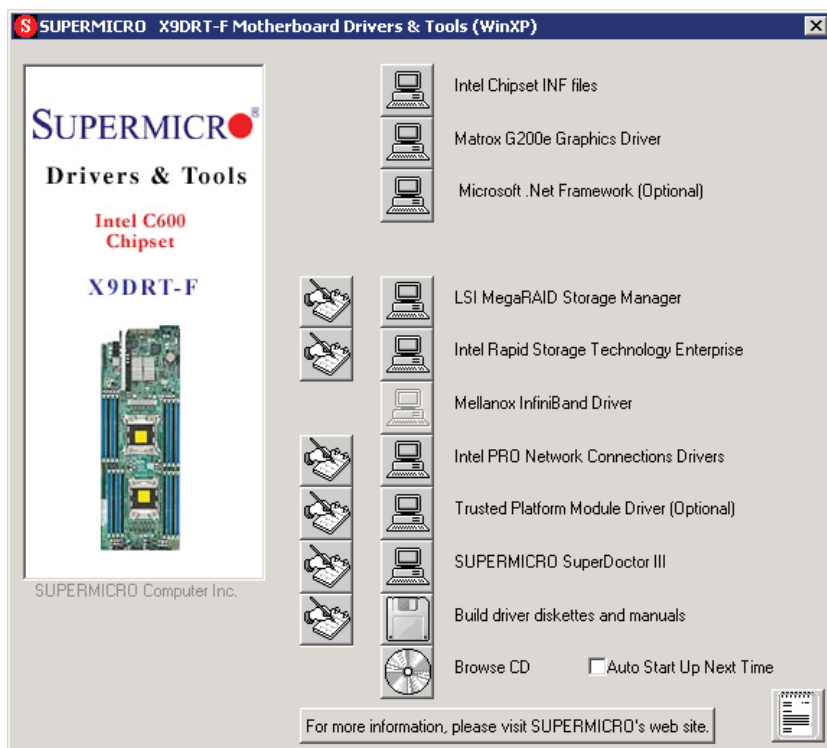

## Supero Doctor III

The SuperDoctor® III program is a Web base management tool that supports remote management capability. It includes Remote and Local Management tools. The local management is called SD III Client. The SuperDoctor III program included on the CD-ROM that came with your serverboard allows you to monitor the environment and operations of your system. SuperDoctor III displays crucial system information such as CPU temperature, system voltages and fan status. See the Figure below for a display of the SuperDoctor III interface.

**Note:** The default User Name and Password for SuperDoctor III is ADMIN / ADMIN.

**Note:** When SuperDoctor is first installed, it adopts the temperature threshold settings that have been set in BIOS. Any subsequent changes to these thresholds must be made within SuperDoctor, as the SuperDoctor settings override the BIOS settings. To set the BIOS temperature threshold settings again, you would first need to uninstall SuperDoctor.

Figure 5-7. Supero Doctor III Interface Display Screen (Health Information)

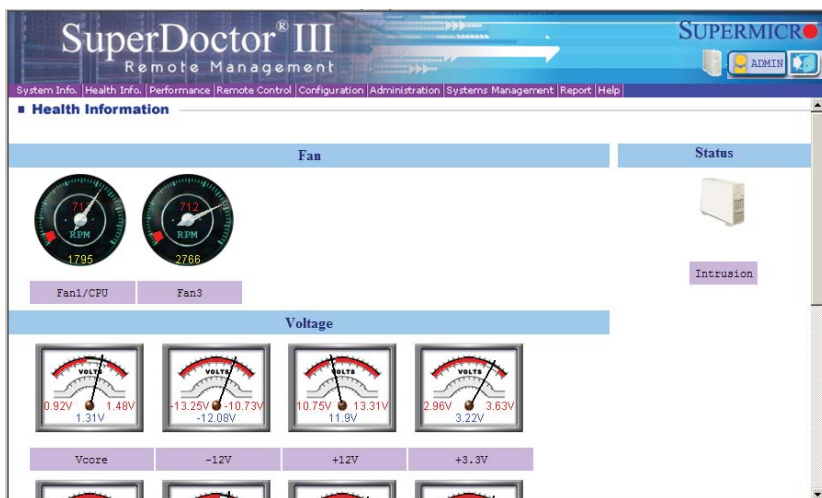
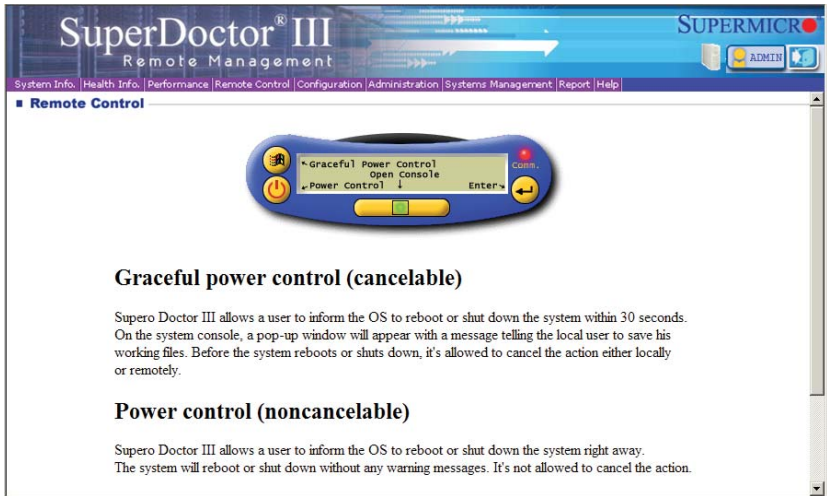

Figure 5-8. Supero Doctor III Interface Display Screen (Remote Control)



**Note:** The SuperDoctor III program and User's Manual can be downloaded from the Supermicro web site at <http://www.supermicro.com/products/accessories/software/SuperDoctorIII.cfm>. For Linux, we recommend that you use the SuperoDoctor II application instead.

## 5-13 Onboard Battery

**Caution:** There is a danger of explosion if the onboard battery is installed upside down, which will reverse its polarities (see Figure 5-9). This battery must be replaced only with the same or an equivalent type recommended by the manufacturer (CR2032). Dispose of used batteries according to the manufacturer's instructions.

**Figure 5-9. Installing the Onboard Battery**

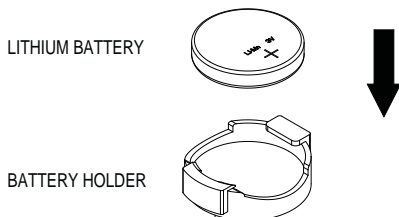

Please handle used batteries carefully. Do not damage the battery in any way; a damaged battery may release hazardous materials into the environment. Do not discard a used battery in the garbage or a public landfill. Please comply with the regulations set up by your local hazardous waste management agency to dispose of your used battery properly.

## Chapter 6

### Advanced Chassis Setup

This chapter covers the steps required to install components and perform maintenance on the SC808BT-1K28BP chassis. For component installation, follow the steps in the order given to eliminate the most common problems encountered. If some steps are unnecessary, skip ahead to the step that follows.

**Tools Required:** The only tool you will need to install components and perform maintenance is a Philips screwdriver.

#### 6-1 Static-Sensitive Devices

Electrostatic discharge (ESD) can damage electronic components. To prevent damage to any printed circuit boards (PCBs), it is important to handle them very carefully. The following measures are generally sufficient to protect your equipment from ESD damage.

##### Precautions

- Use a grounded wrist strap designed to prevent static discharge.
- Touch a grounded metal object before removing any board from its antistatic bag.
- Handle a board by its edges only; do not touch its components, peripheral chips, memory modules or gold contacts.
- When handling chips or modules, avoid touching their pins.
- Put the serverboard, add-on cards and peripherals back into their antistatic bags when not in use.
- For grounding purposes, make sure your computer chassis provides excellent conductivity between the power supply, the case, the mounting fasteners and the serverboard.

##### Unpacking

The serverboard is shipped in antistatic packaging to avoid static damage. When unpacking the board, make sure the person handling it is static protected.

Figure 6-1. Front and Rear Chassis Views

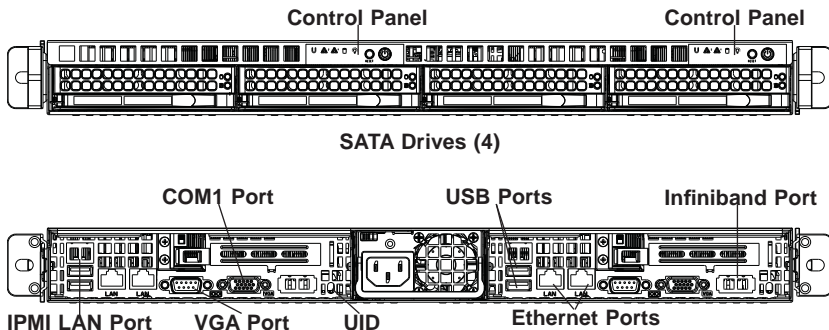

## 6-2 Control Panel

The control panel is located on the front of the chassis. The LEDs inform you of system status.

See Chapter 3 for details on the LEDs and the control panel buttons.

## 6-3 Chassis Cover

Before operating the SC808 chassis for the first time, it is important to remove the protective film covering the top of the chassis, in order to allow for proper ventilation and cooling.

### *Opening the Chassis Cover (Figure 6-2)*

1. Disconnect the chassis from any power source and remove all four screws.
2. Gently push down on the chassis cover in the areas indicated in the illustration.
3. Push the cover toward the rear of the chassis
4. Lift the cover upwards and off the chassis.

**Figure 6-2. Opening the Chassis Cover**

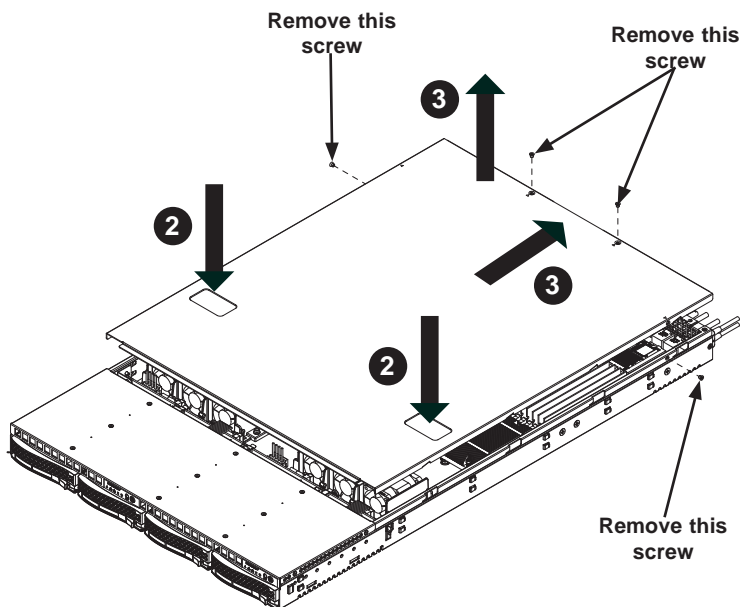

**Caution:** Except for short periods of time, do NOT operate the server without the cover in place. The chassis cover must be in place to allow proper airflow and prevent overheating.

## 6-4 Air Shrouds

Air shrouds concentrate airflow to maximize fan efficiency. The SC808 chassis air shroud does not require screws to set up. The SC808 chassis requires two identical air shrouds.

### *Installing an Air Shroud*

1. Confirm that all six fans are in place and working properly
2. Place the first air shroud into the chassis. The air shroud sits behind the system fans. Each air shroud covers three fans.
3. Install the second air shroud in the same manner as the first.

## 6-5 Checking the Airflow

### *Checking Airflow*

1. Make sure there are no objects obstructing airflow in and out of the server. In addition, if you are using a front bezel, make sure the bezel's filter is replaced periodically.
2. Do not operate the server without drives or drive carriers in the drive bays. Use only recommended server parts.
3. Make sure no wires or foreign objects obstruct air flow through the chassis. Pull all excess cabling out of the airflow path or use shorter cables.
4. The control panel LEDs inform you of system status. See "Chapter 3: System Interface" for details on the LEDs and the control panel buttons.

## 6-6 System Fans

Six fans provide cooling for the chassis (Figure 6-3). These fans circulate air through the chassis as a means of lowering the chassis internal temperature. The SC808 system fans are hot-swappable. There is no need to power-down the system when switching fans.

Figure 6-3: System Fan

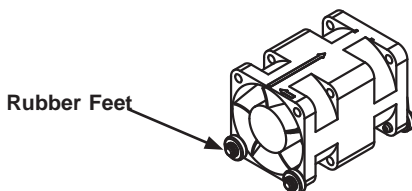

### Changing a System Fan (Figure 6-4)

1. If necessary, open the chassis while the power is running to determine which fan has failed. (Never run the server for an extended period of time with the chassis open.)
2. Remove the failed fan's power cord from the serverboard.
3. Lift the fan from the chassis.
4. Place the new fan into the vacant space in the housing while making sure the arrows on the top of the fan (indicating air direction) point in the same direction as the arrows on the other fans. Make sure all four of the fan's rubber feet are in place.
5. Confirm that the fan is working properly before replacing the chassis cover.

Figure 6-4: System Fan Placement

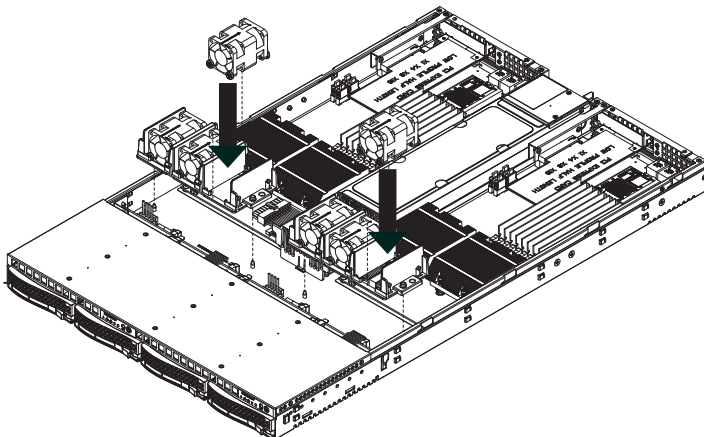

## 6-7 Installing and Removing Hard Drives

### Accessing the Drive Bays

SATA Drives: You do not need to access the inside of the chassis or remove power to replace or swap SATA drives. Each hard disk drive is in a separate carrier that may be removed to access its hard drive. Proceed to the next step for instructions. You must use standard 1" high, SATA drives in the system.

**Caution:** Except for short periods of time (swapping hard drives), do not operate the server with the carriers absent.

#### *Removing Hard Drive Carriers from the Chassis (Figure 6-5)*

1. Press the release button on the drive carrier. This extends the drive handle.
2. Use the handle to pull the drive out of the chassis.

**Figure 6-5: Removing Hard Drive**

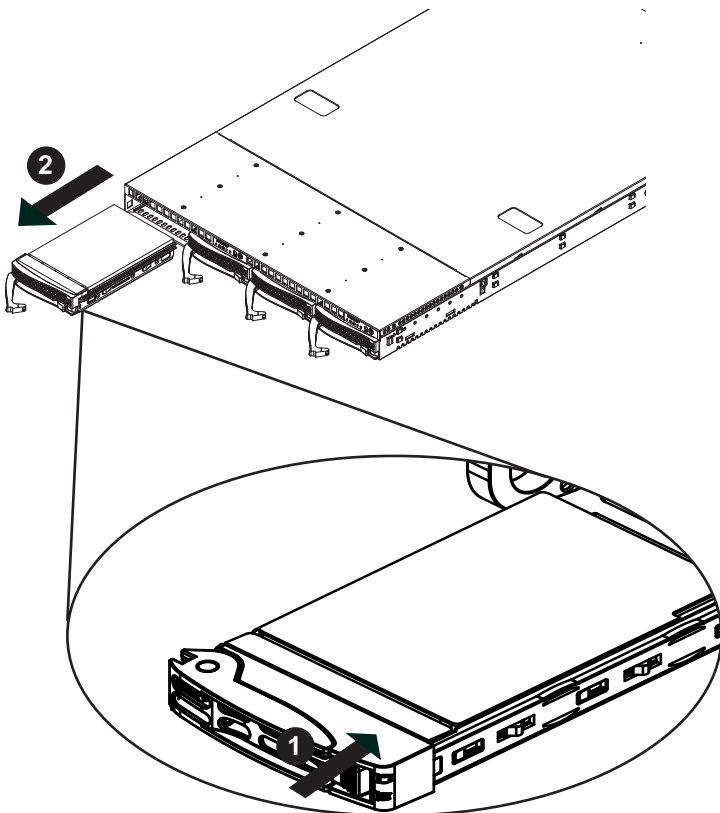

The drives are mounted in drive carriers to simplify their installation and removal from the chassis. These carriers also help promote proper airflow in the drive bays (Figure 6-6).

**Figure 6-6: Chassis Drive Carrier**

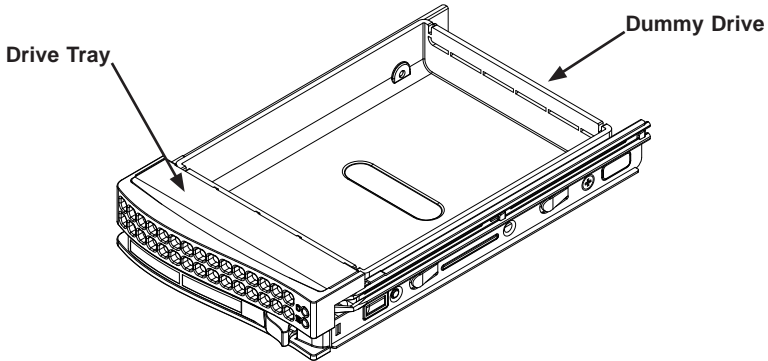

**Installing a Drive into the Hard Drive Carrier**

1. Remove the two screws securing the dummy drive to the drive carrier (Figure 6-7).

**Figure 6-7: Removing Dummy Drive from Carrier**

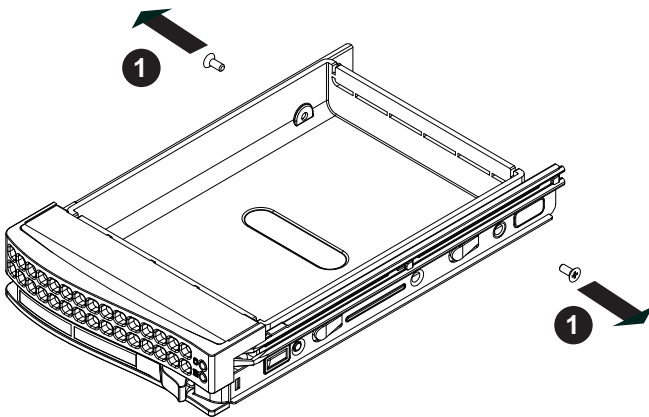

2. Lift the dummy drive up and out of the carrier.
3. Install a new drive into the carrier with the printed circuit board side facing downward so that the mounting holes align with those in the carrier.
4. Secure the hard drive by tightening all six screws (Figure 6-8).

Figure 6-8: Removing Hard Drive

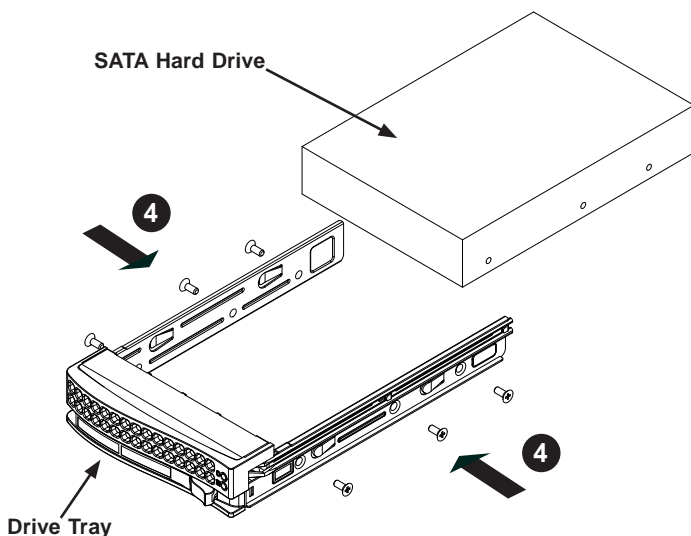

5. Use the open handle to slide the drive carrier into the chassis.
6. Close the drive carrier handle.

**Caution!** Enterprise level hard disk drives are recommended for use in Supermicro chassis and servers. For information on recommended HDDs, visit the Supermicro Web site at <http://www.supermicro.com/products/nfo/files/storage/SAS-1-ComplList-110909.pdf>

## 6-8 Installing the Serverboard

### I/O Shield

The I/O shield holds the serverboard ports in place. The I/O shield does not require installation, however, the serverboard must match up with the I/O shield (Figure 6-9).

Figure 6-9: I/O Shield Placement

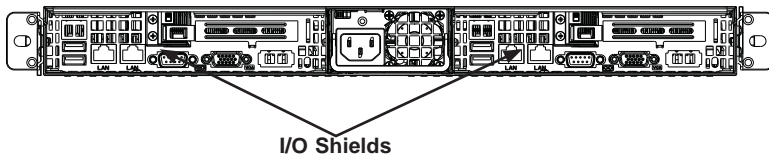

### Permanent and Optional Standoffs

Standoffs prevent short circuits by securing space between the serverboard and the chassis surface. The SC808 chassis includes permanent standoffs in locations used by the serverboards. These standoffs accept the rounded Phillips head screws included in the SC808 accessories packaging.

Some serverboards require additional screws for heatsinks, general components and for stability. Optional standoffs are used for these serverboards.

To use an optional standoff, you must place a hexagonal screw through the bottom the chassis and secure the screw with the hexagonal nut (rounded side up).

Depending upon the configuration of the serverboard being used, it is also possible that some of the optional standoffs which are pre-installed in the chassis, may need to be removed.

#### ***Installing the Serverboard (Figure 6-10)***

1. Review the documentation that came with your serverboard. Become familiar with component placement, requirements, precautions, and cable connections.
2. Disconnect the chassis from any power source and open the chassis cover.
3. Remove the expansion card brackets. To do this:
  - A. Remove screw securing the expansion card bracket to the chassis.
  - B. Lift the bracket out of the chassis.
  - C. Repeat this process for the second riser card.
4. Lay the first serverboard in the chassis aligning the standoffs

5. Secure the serverboard to the chassis using the rounded, Phillips head screws. Each serverboard requires five screws. Do not exceed eight pounds of torque when tightening down the serverboard.
6. Repeat steps 3 - 5 for the second side of the chassis.
7. Secure the CPU(s), heatsinks, and other components to the serverboard as described in the serverboard documentation.
8. Connect the cables between the serverboard, backplane, chassis, front panel, and power supply, as needed. Also, fans may be temporarily removed to allow access to the backplane ports.
9. Replace the expansion card bracket and secure the bracket with a screw.

**Figure 6-10: Expansion Card Bracket**

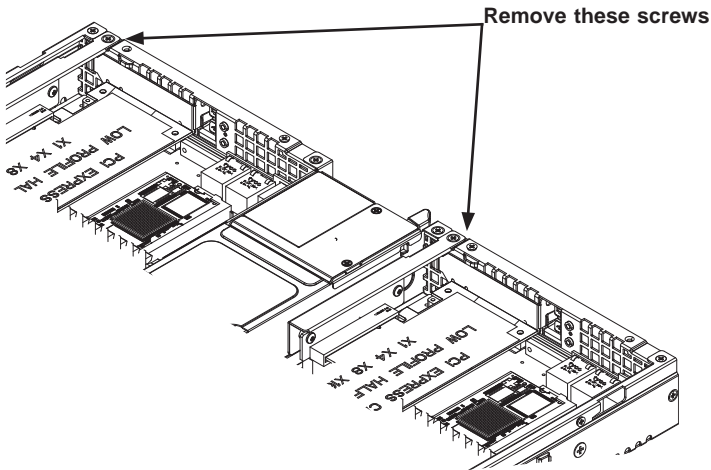

## 6-9 Expansion Slot Setup

SC808 chassis includes I/O slots for expansion cards. Each side supports one low profile, half-length expansion card for a total of two per system (Figure 6-11).

Figure 6-11: Expansion Card Placement

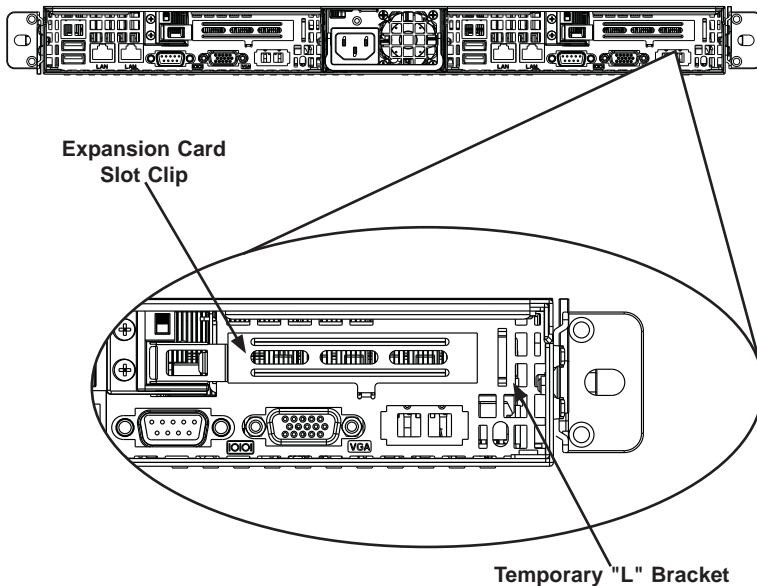

### *Installing Expansion Cards (Figure 6-12)*

1. Disconnect the chassis from any power source, lay the chassis on a flat surface, and open the chassis cover.
2. Pull open the expansion card slot clip in the rear of the chassis.
3. Slide the temporary expansion card "L" bracket toward the slot clip and remove the temporary bracket from the chassis.
4. Connect the expansion card to the riser card and slide the expansion card "L" bracket in to the rear expansion card slot.
5. Close the expansion card slot clip.
6. Close the chassis cover and reconnect the chassis to the power source.

**Note:** Under normal circumstances, the riser card and expansion card bracket are not separated.

Figure 6-12: Installing Expansion Cards

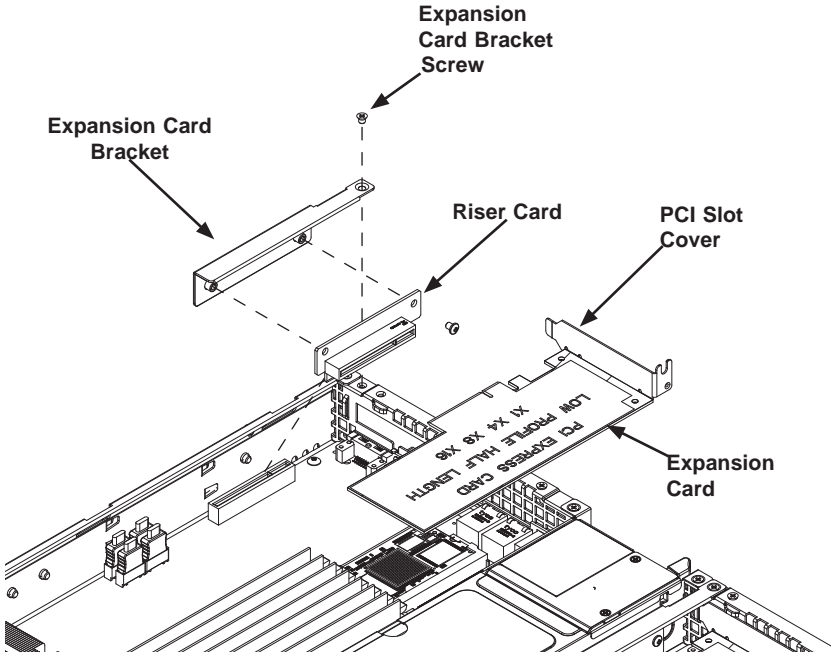

## 6-10 Power Supply

Depending on your chassis model, the SC808 Chassis has a 780, 980 or 1200 Watt power supply. This power supply is auto-switching capable. This enables it to automatically sense and operate at a 100v to 240v input voltage. An amber light will be illuminated on the power supply when the power is off. An illuminated green light indicates that the power supply is operating.

### Power Supply Replacement

The SC808 chassis utilizes one power supply. In the unlikely event that the power supply unit must be replaced, the system will shut down. Replacement units can be ordered directly from Supermicro (see contact information in the Preface).

#### ***Changing the Power Supply (Figure 6-13)***

1. Power down the chassis and unplug the AC power cord.
2. Push the release tab (on the back of the power supply) as illustrated.
3. Pull the power supply out using the handle provided.
4. Push the new power supply module into the power bay until you hear a click.
5. Plug the AC power cord back into the module and power up the server.

Figure 6-13: Changing the Power Supply

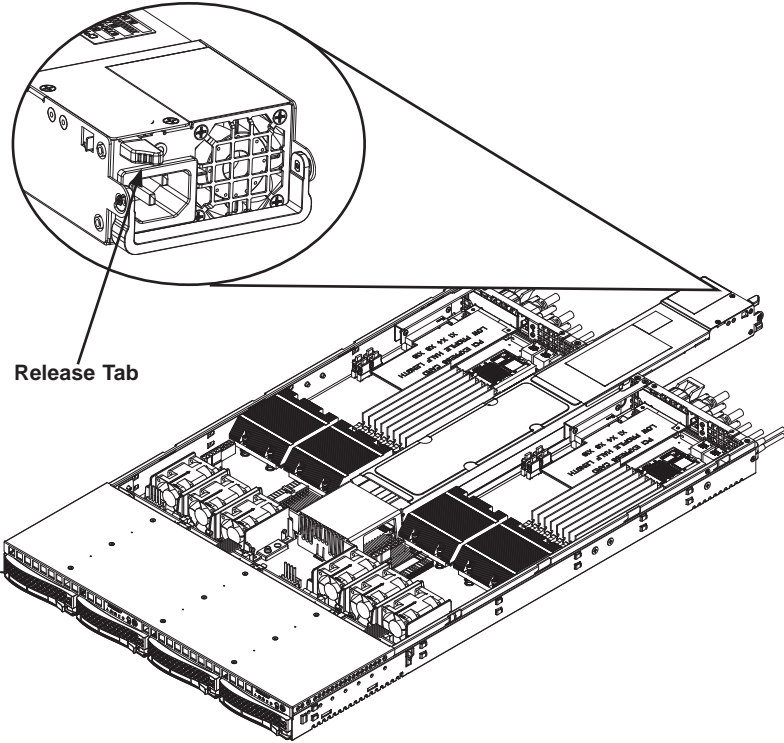

## Chapter 7

# BIOS

### 7-1 Introduction

This chapter describes the AMI BIOS Setup Utility for the X9DRT-IBQF/IBFF/F serverboard. The 128 MB AMI BIOS® is stored in a Flash EEPROM and can be easily updated. This chapter describes the basic navigation of the AMI BIOS Setup Utility setup screens.

#### Starting BIOS Setup Utility

To enter the AMI BIOS Setup Utility screens, press the <Delete> key while the system is booting up.

**Note:** In most cases, the <Delete> key is used to invoke the AMI BIOS setup screen. There are a few cases when other keys are used, such as <F1>, <F2>, etc.

Each main BIOS menu option is described in this manual. The Main BIOS setup menu screen has two main frames. The left frame displays all the options that can be configured. Grayed-out options cannot be configured. Options in blue can be configured by the user. The right frame displays the key legend. Above the key legend is an area reserved for a text message. When an option is selected in the left frame, it is highlighted in white. Often a text message will accompany it. (**Note:** the AMI BIOS has default text messages built in. Supermicro retains the option to include, omit, or change any of these text messages.)

The AMI BIOS Setup Utility uses a key-based navigation system called "hot keys". Most of the AMI BIOS setup utility "hot keys" can be used at any time during the setup navigation process. These keys include <F1>, <F10>, <Enter>, <ESC>, arrow keys, etc.

**Note:** Options printed in **Bold** are default settings.

#### How To Change the Configuration Data

The configuration data that determines the system parameters may be changed by entering the AMI BIOS Setup utility. This Setup utility can be accessed by pressing <Del> at the appropriate time during system boot.

## Starting the Setup Utility

Normally, the only visible Power-On Self-Test (POST) routine is the memory test. As the memory is being tested, press the <Delete> key to enter the main menu of the AMI BIOS Setup Utility. From the main menu, you can access the other setup screens. An AMI BIOS identification string is displayed at the left bottom corner of the screen below the copyright message.

**Caution!** Do not upgrade the BIOS unless your system has a BIOS-related issue. Flashing the wrong BIOS can cause irreparable damage to the system. In no event shall Supermicro be liable for direct, indirect, special, incidental, or consequential damages arising from a BIOS update. If you have to update the BIOS, do not shut down or reset the system while the BIOS is updating. This is to avoid possible boot failure.

## 7-2 Main Setup

When you first enter the AMI BIOS Setup utility, you will enter the Main setup screen. You can always return to the Main setup screen by selecting the Main tab on the top of the screen. The Main BIOS Setup screen is shown below.

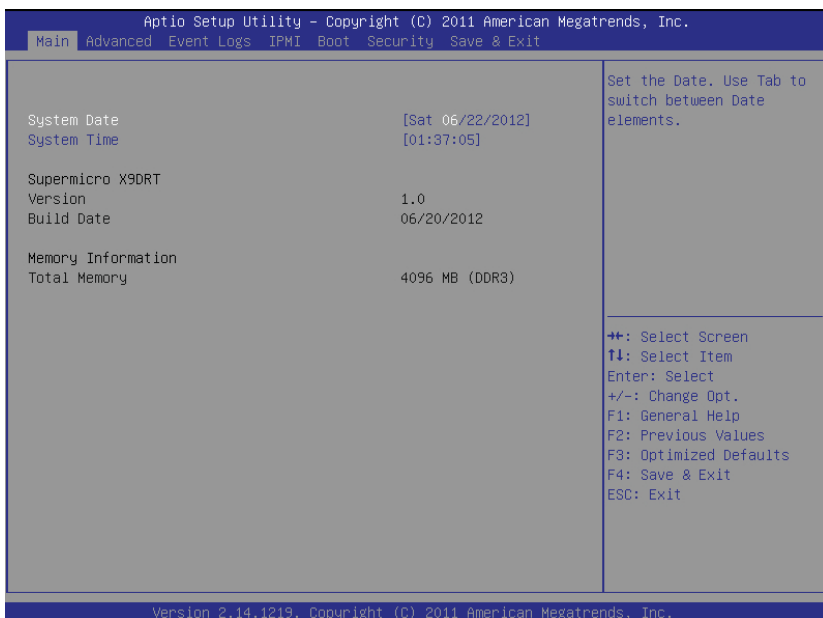

The AMI BIOS Main menu displays the following information:

**System Date/System Time**

Use this option to change the system time and date. Highlight *System Time* or *System Date* using the arrow keys. Enter new values through the keyboard and press <Enter>. Press the <Tab> key to move between fields. The date must be entered in Day MM/DD/YY format. The time is entered in HH:MM:SS format. (**Note:** The time is in the 24-hour format. For example, 5:30 P.M. appears as 17:30:00.).

**Supermicro X9DRT****Version**

This item displays the SMC version of the BIOS ROM used in this system.

**Build Date**

This item displays the date that the BIOS Setup utility was built.

**Memory Information****Total Memory**

This displays the amount of memory that is available in the system.

## 7-3 Advanced Settings Menu

Select the Advanced tab to access the following submenu items.

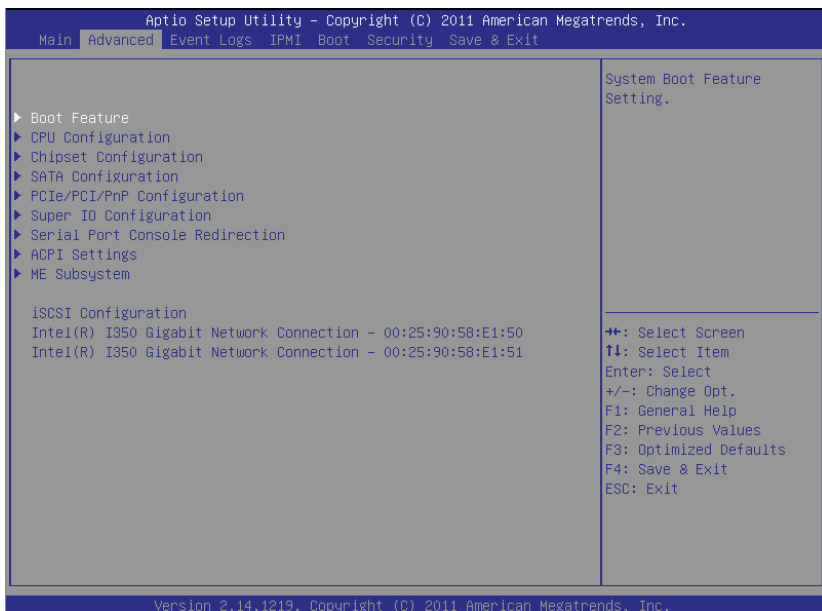

### ► Boot Features

#### Quiet Boot

This feature allows the user to select bootup screen display between POST messages and the OEM logo. Select Disabled to display the POST messages. Select Enabled to display the OEM logo instead of the normal POST messages. The options are **Enabled** and Disabled.

#### AddOn ROM Display Mode

Use this item to set the display mode for the Option ROM. Select Keep Current to use the current AddOn ROM Display setting. Select Force BIOS to use the Option ROM display mode set by the system BIOS. The options are **Force BIOS** and Keep Current.

#### Bootup Num-Lock

Use this feature to set the Power-on state for the Numlock key. The options are Off and **On**.

### **Wait For 'F1' If Error**

Select Enabled to force the system to wait until the 'F1' key is pressed if an error occurs. The options are Disabled and **Enabled**.

### **Interrupt 19 Capture**

Interrupt 19 is the software interrupt that handles the boot disk function. When this item is set to Enabled, the ROM BIOS of the host adaptors will "capture" Interrupt 19 at bootup and allow the drives that are attached to these host adaptors to function as bootable disks. If this item is set to Disabled, the ROM BIOS of the host adaptors will not capture Interrupt 19, and the drives attached to these adaptors will not function as bootable devices. The options are **Enabled** and Disabled.

### **Re-try Boot**

When set to Enabled, the BIOS will continuously retry to boot from the selected boot type. The options are **Disabled**, Legacy Boot, and EFI Boot.

## **Power Configuration**

### **Watch Dog Function**

If enabled, the Watch Dog timer will allow the system to automatically reboot when a non-recoverable error occurs that lasts for more than five minutes. The options are Enabled and **Disabled**.

### **Power Button Function**

If this feature is set to Instant Off, the system will power off immediately as soon as the user presses the power button. If this feature is set to 4 Seconds Override, the system will power off when the user presses the power button for 4 seconds or longer. The options are **Instant Off** and 4 Seconds Override.

### **Restore on AC Power Loss**

Use this feature to set the power state after a power outage. Select Stay Off for the system power to remain off after a power loss. Select Power On for the system power to be turned on after a power loss. Select Last State to allow the system to resume its last state before a power loss. The options are Power On, Stay Off, and **Last State**.

## ► CPU Configuration

This submenu displays the information of the CPU as detected by the BIOS. It also allows the user to configure CPU settings.

### ► Socket 1 CPU Information, Socket 2 CPU Information

This submenu displays the following information regarding the CPUs installed in Socket 1 and Socket 2.

- Type of CPU
- CPU Signature
- Microcode Patch
- CPU Stepping
- Maximum CPU Speed
- Minimum CPU Speed
- Processor Cores
- Intel HT (Hyper-Threading) Technology
- Intel VT-x Technology
- Intel SMX Technology
- L1 Data Cache
- L1 Code Cache
- L2 Cache
- L3 Cache

#### **CPU Speed**

This item displays the speed of the CPU installed in Socket 1/Socket 2.

#### **64-bit**

This item indicates if the CPU installed in Socket 1 or Socket 2 supports 64-bit technology.

#### **Clock Spread Spectrum**

Select Enable to enable Clock Spread Spectrum support, which will allow the BIOS to monitor and attempt to reduce the level of Electromagnetic Interference caused by the components whenever needed. The options are **Disabled** and Enabled.

#### **RTID (Record Types IDs)**

This feature displays the total number of Record Type IDs for local and remote pools. The options are **Optimal** and Alternate.

---

### **Hyper-threading**

Select Enabled to support Intel Hyper-threading Technology to enhance CPU performance. The options are **Enabled** and Disabled.

### **Active Processor Cores**

Set to Enabled to use a processor's second core and above. (Please refer to Intel's website for more information.) The options are **All**, 1, 2, 4, and 6.

### **Limit CPUID Maximum**

This feature allows the user to set the maximum CPU ID value. Enable this function to boot the legacy operating systems that cannot support processors with extended CPUID functions. The options are Enabled and **Disabled** (for the Windows OS).

### **Execute-Disable Bit (Available if supported by the OS & the CPU)**

Select Enabled to enable the Execute Disable Bit which will allow the processor to designate areas in the system memory where an application code can execute and where it cannot, thus preventing a worm or a virus from flooding illegal codes to overwhelm the processor or damage the system during an attack. The default is **Enabled**. (Refer to Intel and Microsoft Web sites for more information.)

### **Intel® AES-NI**

Select Enable to use the Intel Advanced Encryption Standard (AES) New Instructions (NI) to ensure data security. The options are **Enabled** and Disabled.

### **MLC Streamer Prefetcher (Available when supported by the CPU)**

If set to Enabled, the MLC (mid-level cache) streamer prefetcher will prefetch streams of data and instructions from the main memory to the L2 cache to improve CPU performance. The options are Disabled and **Enabled**.

### **MLC Spatial Prefetcher (Available when supported by the CPU)**

If this feature is set to Disabled, The CPU prefetches the cache line for 64 bytes. If this feature is set to Enabled the CPU fetches both cache lines for 128 bytes as comprised. The options are Disabled and **Enabled**.

### **DCU Streamer Prefetcher (Available when supported by the CPU)**

Select Enabled to support Data Cache Unit (DCU) prefetch of L1 data to speed up data accessing and processing in the DCU to enhance CPU performance. The options are Disabled and **Enabled**.

### **DCU IP Prefetcher**

Select Enabled for DCU (Data Cache Unit) IP Prefetcher support, which will prefetch IP addresses to improve network connectivity and system performance. The options are **Enabled** and Disabled.

### **Intel® Virtualization Technology (Available when supported by the CPU)**

Select Enabled to support Intel Virtualization Technology, which will allow one platform to run multiple operating systems and applications in independent partitions, creating multiple "virtual" systems in one physical computer. The options are **Enabled** and Disabled.

**Note:** If there is any change to this setting, you will need to power off and restart the system for the change to take effect. Please refer to Intel's website for detailed information.)

## **► CPU Power Management Configuration**

This submenu allows the user to configure the following CPU Power Management settings.

### **Power Technology**

Select Energy Efficient to support power-saving mode. Select Custom to customize system power settings. Select Disabled to disable power-saving settings. The options are Disabled, **Energy Efficient**, and Custom. If the option is set to Custom, the following items will display:

#### **EIST (Available when Power Technology is set to Custom)**

EIST (Enhanced Intel SpeedStep Technology) allows the system to automatically adjust processor voltage and core frequency to reduce power consumption and heat dissipation. The options are Disabled and **Enabled**.

#### **Turbo Mode (Available when Power Technology is set to Custom and EIST is Enabled)**

Select Enabled to use the Turbo Mode to boost system performance. The options are **Enabled** and Disabled.

#### **C1E (Available when Power Technology is set to Custom)**

Select Enabled to enable Enhanced C1 Power State to boost system performance. The options are **Enabled** and Disabled.

**CPU C3 Report (Available when Power Technology is set to Custom)**

Select Enabled to allow the BIOS to report the CPU C3 State (ACPI C2) to the operating system. During the CPU C3 State, the CPU clock generator is turned off. The options are Enabled and **Disabled**.

**CPU C6 Report (Available when Power Technology is set to Custom)**

Select Enabled to allow the BIOS to report the CPU C6 State (ACPI C3) to the operating system. During the CPU C6 State, the power to all cache is turned off. The options are **Enabled** and Disabled.

**CPU C7 Report (Available when Power Technology is set to Custom)**

Select Enabled to allow the BIOS to report the CPU C7 State (ACPI C3) to the operating system. CPU C7 State is a processor-specific low C-State. The options are **Enabled** and Disabled.

**Package C State limit (Available when Power Technology is set to Custom)**

This feature allows the user to set the limit on the C-State package register. The options are C0, C2, **C6**, and No Limit.

**Energy/Performance Bias**

Use this feature to select an appropriate fan setting to achieve maximum system performance (with maximum cooling) or maximum energy efficiency with maximum power saving). The fan speeds are controlled by the firmware management via IPMI 2.0. The options are Performance, **Balanced Performance**, Balanced Energy, and Energy Efficient.

**Factory Long Duration Power Limit**

This item displays the power limit (in watts) set by the manufacturer during which long duration power is maintained.

**Long Duration Power Limit**

This item displays the power limit (in watts) set by the user during which long duration power is maintained. The default setting is 0.

**Factory Long Duration Maintained**

This item displays the period of time (in seconds) set by the manufacturer during which long duration power is maintained.

**Long Duration Maintained**

This item displays the period of time (in seconds) during which long duration power is maintained. The default setting is 0.

### **Recommended Short Duration Power Limit**

This item displays the short duration power settings (in watts) recommended by the manufacturer.

### **Short Duration Power Limit**

This item displays the time period during which short duration power (in watts) is maintained. The default setting is 0.

## **► Chipset Configuration**

### **► North Bridge**

This feature allows the user to configure the settings for the Intel North Bridge.

#### **► Integrated IO Configuration**

##### **Intel® VT-d**

Select Enabled to enable Intel Virtualization Technology support for Direct I/O VT-d by reporting the I/O device assignments to the VMM (Virtual Machine Monitor) through the DMAR ACPI Tables. This feature offers fully-protected I/O resource sharing across Intel platforms, providing greater reliability, security and availability in networking and data-sharing. The options are **Enabled** and Disabled.

##### **Intel® I/OAT**

Select Enabled to enable Intel I/OAT (I/O Acceleration Technology), which significantly reduces CPU overhead by leveraging CPU architectural improvements and freeing the system resource for other tasks. The options are Disabled and **Enabled**.

##### **DCA Support**

When set to Enabled, this feature uses Intel's DCA (Direct Cache Access) Technology to improve data transfer efficiency. The default setting is **Enabled**.

##### **I/O 1 PCIe Port Bifurcation Control**

This submenu configures the following IO PCIe Port Bifurcation Control settings for I/O 1 PCIe ports to determine how the available PCI-Express lanes to be distributed between the PCI-Exp. Root Ports.

**Port 1A Link Speed**

Select GEN1 to enable PCI-Exp Generation 1 support for the port. Select GEN2 to enable PCI-Exp Generation 2 support for the port. Select GEN3 to enable PCI-Exp Generation 3 support for the port. The options are **GEN1**, GEN2, and GEN3.

**Port 1B Link Speed**

Select GEN1 to enable PCI-Exp Generation 1 support for the port. Select GEN2 to enable PCI-Exp Generation 2 support for the port. Select GEN3 to enable PCI-Exp Generation 3 support for the port. The options are GEN1, GEN2, and **GEN3**.

**Port 2A Link Speed**

Select GEN1 to enable PCI-Exp Generation 1 support for the port. Select GEN2 to enable PCI-Exp Generation 2 support for the port. Select GEN3 to enable PCI-Exp Generation 3 support for the port. The options are GEN1, GEN2, and **GEN3**.

**IIO 2 PCIe Port Bifurcation Control**

This submenu configures the following IO PCIe Port Bifurcation Control settings for IIO 2 PCIe ports to determine how the available PCI-Express lanes to be distributed between the PCI-Exp. Root Ports.

**►QPI Configuration****Current QPI Link Speed**

This item displays the current status of the QPI Link.

**Current QPI Link Frequency**

This item displays the frequency of the QPI Link.

**Isoc**

Select Enabled to enable Isochronous support to meet QoS (Quality of Service) requirements. This feature is especially important for virtualization technology. The options are Enabled and **Disabled**.

**QPI (Quick Path Interconnect) Link Speed Mode**

Use this feature to select data transfer speed for QPI Link connections. The options are **Fast** and Slow.

### **QPI Link Frequency Select**

Use this feature to select the desired QPI frequency. The options are **Auto**, 6.4 GT/s, 7.2 GT/s, and 8.0 GT/s.

### **►DIMM Configuration**

This section displays the following DIMM information.

#### **Current Memory Mode**

This item displays the current memory mode.

#### **Current Memory Speed**

This item displays the current memory speed.

#### **Mirroring**

This item displays if memory mirroring is supported by the serverboard. Memory mirroring creates a duplicate copy of the data stored in the memory to enhance data security.

#### **Sparing**

This item displays if memory sparing is supported by the serverboard. Memory sparing enhances system performance.

### **►DIMM Information**

The status of the memory modules detected by the BIOS is displayed.

#### **Memory Mode**

When Independent is selected, all DIMMs are available to the operating system. When Mirroring is selected, the serverboard maintains two identical copies of all data in memory for data backup. When Lock Step is selected, the serverboard uses two areas of memory to run the same set of operations in parallel. The default setting is **Independent**.

#### **DRAM RAPL Mode**

RAPL (Running Average Power Limit) provides mechanisms to enforce power consumption limits on supported processors. The options are DRAM RAPL MODE0 , **DRAM RAPL MODE1**, and Disabled.

### **Memory Energy/Performance**

Use this feature to determine the parameters for memory module energy consumption. Select Performance to maintain optimal functionality or select Energy Saving to reduce power consumption. The options are **Performance** and Energy Saving.

### **DDR Speed**

Use this feature to force a DDR3 memory module to run at a frequency other than what is specified in the specification. The options are **Auto**, Force DDR3-800, Force DDR3-1066, Force DDR3-1333, Force DDR3-1600 and Force SPD.

### **Channel Interleaving**

This feature selects from the different channel interleaving methods. The options are **Auto**, 1 Way, 2 Way, 3, Way, and 4 Way.

### **Rank Interleaving**

This feature allows the user to select a rank memory interleaving method. The options are **Auto**, 1 Way, 2 Way, 4, Way, and 8 Way.

### **Patrol Scrub**

Patrol Scrubbing is a process that allows the CPU to correct correctable memory errors detected on a memory module and send the correction to the requestor (the original source). When this item is set to Enabled, the IO hub will read and write back one cache line every 16K cycles, if there is no delay caused by internal processing. By using this method, roughly 64 GB of memory behind the IO hub will be scrubbed every day. The options are **Enabled** and Disabled.

### **Demand Scrub**

Demand Scrubbing is a process that allows the CPU to correct correctable memory errors found on a memory module. When the CPU or I/O issues a demand-read command, and the read data from memory turns out to be a correctable error, the error is corrected and sent to the requestor (the original source). Memory is updated as well. Select Enabled to use Demand Scrubbing for ECC memory correction. The options are Enabled and **Disabled**.

### **Data Scrambling**

Select Enabled to enable data scrambling to ensure data security and integrity. The options are Disabled and **Enabled**.

### Device Tagging

Select Enabled to support device tagging. The options are **Disabled** and **Enabled**.

### Thermal Throttling

Throttling improves reliability and reduces power consumption in the processor via automatic voltage control during processor idle states. The options are Disabled and **CLTT** (Closed Loop Thermal Throttling).

## ► South Bridge Configuration

This feature allows the user to configure the settings for the Intel PCH chip.

### PCH Information

This feature displays the following PCH information.

**Name:** This item displays the name of the PCH chip.

**Stepping:** This item displays the status of the PCH stepping.

**USB Devices:** This item displays the USB devices detected by the BIOS.

### All USB Devices

This feature enables all USB ports/devices. The options are Disabled and **Enabled**.

### EHCI Controller 1/EHCI Controller 2 (Available when All USB Devices is set to Enabled)

Select Enabled to enable EHCI (Enhanced Host Controller Interface) Controller 1 or Controller 2. The options are Disabled and **Enabled**.

### Legacy USB Support (Available when USB Functions is not Disabled)

Select Enabled to support legacy USB devices. Select Auto to disable legacy support if USB devices are not present. Select Disabled to have USB devices available for EFI (Extensive Firmware Interface) applications only. The settings are Disabled, **Enabled** and Auto.

### Port 60/64 Emulation

Select Enabled to enable I/O port 60h/64h emulation support for the legacy USB keyboard so that it can be fully supported by the operating systems that does not recognize a USB device. The options are Disabled and **Enabled**.

### **EHCI Hand-Off**

This item is for operating systems that do not support Enhanced Host Controller Interface (EHCI) hand-off. When enabled, EHCI ownership change will be claimed by the EHCI driver. The options are **Disabled** and Enabled.

## **► SATA Configuration**

When this submenu is selected, the AMI BIOS automatically detects the presence of IDE or SATA devices and displays the following items.

**SATA Port0~SATA Port5:** The AMI BIOS displays the status of each SATA port as detected by the BIOS.

### **SATA Mode**

Use this feature to configure SATA mode for a selected SATA port. The options are Disabled, IDE Mode, **AHCI Mode** and RAID Mode. The following are displayed depending on your selection:

#### **IDE Mode**

The following items are displayed when IDE Mode is selected:

##### **Serial-ATA (SATA) Controller 0~1**

Use this feature to activate or deactivate the SATA controller, and set the compatibility mode. The options are Disabled, Enhanced, and Compatible. The default for SATA Controller 0 is **Compatible**. The default of SATA Controller 1 is **Enhanced**.

#### **AHCI Mode**

The following items are displayed when the AHCI Mode is selected.

##### **Aggressive Link Power Management**

When Enabled, the SATA AHCI controller manages the power usage of the SATA link. The controller will put the link in a low power mode during extended periods of I/O inactivity, and will return the link to an active state when I/O activity resumes. The options are **Enabled** and Disabled.

##### **Port 0~5 Hot Plug**

Select Enabled to enable hot-plug support for a particular port, which will allow the user to change a hardware component or device without shutting down the system. The options are **Enabled** and Disabled.

**Port 0-5 Staggered Spin Up**

Select Enabled to enable Staggered Spin-up support to prevent excessive power consumption caused by multiple HDDs spinning-up simultaneously. The options are Enabled and **Disabled**.

**RAID Mode**

The following items are displayed when RAID Mode is selected:

**Port 0-5 Hot Plug**

Select Enabled to enable hot-plug support for the particular port. The options are **Enabled** and Disabled.

**► PCIe/PCI/PnP Configuration****Storage Add-on Card OpROM Priority**

Use this feature to select the Option ROM to boot the system when there are multiple Option ROMs available in the system. The options are EFI Compatible ROM and **Legacy**.

**PCI Latency Timer**

Use this feature to set the latency Timer of each PCI device installed on a PCI bus. Select 64 to set the PCI latency to 64 PCI clock cycles. The options are 32, **64**, 96, 128, 160, 192, 224 and 248.

**Above 4G Decoding (Available if the system supports 64-bit PCI decoding)**

Select Enabled to decode a PCI device that supports 64-bit in the space above 4G Address. The options are Enabled and **Disabled**.

**PERR# Generation**

Select Enabled to allow a PCI device to generate a PERR number for a PCI Bus Signal Error Event. The options are Enabled and **Disabled**.

**SERR# Generation**

Select Enabled to allow a PCI device to generate an SERR number for a PCI Bus Signal Error Event. The options are Enabled and **Disabled**.

**Maximum Payload**

Select Auto to allow the system BIOS to automatically set the maximum payload value for a PCI-E device to enhance system performance. The options are **Auto**, 128 Bytes and 256 Bytes.

### Maximum Read Request

Select Auto to allow the system BIOS to automatically set the maximum Read Request size for a PCI-E device to enhance system performance. The options are **Auto**, 128 Bytes, 256 Bytes, 512 Bytes, 1024 Bytes, 2048 Bytes, and 4096 Bytes.

### ASPM Support

This feature allows the user to set the Active State Power Management (ASPM) level for a PCI-E device. Select Force L0s to force all PCI-E links to operate at L0s state. Select Auto to allow the system BIOS to automatically set the ASPM level for the system. Select Disabled to disable ASPM support. The options are **Disabled**, Force L0s, and Auto.

**Caution:** Enabling ASPM support may cause some PCI-E devices to fail!

### PCI-E x16 OPROM

Select Enabled to enable Option ROM support to boot the computer using a device installed on the slot specified above. The options are **Enabled** and Disabled.

### Onboard LAN Option ROM Select

Select iSCSI to use the iSCSI Option ROM to boot the computer using a network device. Select PXE (Preboot Execution Environment) to use an PXE Option ROM to boot the computer using a network device. The options are iSCSI and **PXE**.

### Load Onboard LAN1 Option ROM, Load Onboard LAN2 Option ROM

Select Enabled to enable the onboard LAN1/LAN2 Option ROM. This is to boot the computer using a network device. The default setting for LAN1 Option ROM is **Enabled**, and the default setting for LAN2 Option ROM is **Disabled**.

### VGA Priority

This feature allows the user to select the graphics adapter to be used as the primary boot device. The options are **Onboard**, and Offboard.

### Network Stack

Select Enabled enable PXE (Preboot Execution Environment) or UEFI (Unified Extensible Firmware Interface) for network stack support. The options are Enabled and **Disabled**.

## ► Super IO Configuration

**Super IO Chip:** This item displays the Super IO chip used in the serverboard.

### ► COM Configuration

#### Serial Port

Select Enabled to enable a serial port specified by the user. The options are **Enabled** and Disabled.

#### Device Settings

This item displays the settings of Serial Port 1 (COM).

#### Change Settings

This option specifies the base I/O port address and the Interrupt Request address of Serial Port 1 (COM). Select Disabled to prevent the serial port from accessing any system resources. When this option is set to Disabled, the serial port becomes unavailable. The options are **Auto**, IO=3F8h; IRQ=4; IO=3F8h; IRQ=3; IO=2F8h; IRQ=3; IO=3E8h; IRQ=5; IO=2E8h; IRQ=7; IO=3F8h; IRQ=3, 4, 5, 6, 7, 10, 11, 12; IO=2F8h; IRQ=3, 4, 5, 6, 7, 10, 11, 12; IO=3E8h; IRQ=3, 4, 5, 6, 7, 10, 11, 12; and IO=2E8h; IRQ=3, 4, 5, 6, 7, 10, 11, 12;

#### Device Mode

Use this feature to select the desired mode for a serial port specified. The options are **Normal** and High Speed.

## ► SOL Configuration

### Serial Port

Select Enabled to enable a serial port specified by the user. The options are **Enabled** and Disabled.

### Device Settings

This item displays the settings of Serial Port 2 (SOL).

### Change Settings

This option specifies the base I/O port address and the Interrupt Request address of Serial Port 2 (SOL). Select Disabled to prevent the serial port from accessing any system resources. When this option is set to Disabled, the serial port becomes unavailable. The options are **Auto**, IO=3F8h; IRQ=4; IO=3F8h; IRQ=3; IO=2F8h; IRQ=3; IO=3E8h; IRQ=5; IO=2E8h; IRQ=7; IO=3F8h; IRQ=3, 4, 5, 6, 7, 10, 11, 12; IO=2F8h; IRQ=3, 4, 5, 6, 7, 10, 11, 12; IO=3E8h; IRQ=3, 4, 5, 6, 7, 10, 11, 12; and IO=2E8h; IRQ=3, 4, 5, 6, 7, 10, 11, 12;

### Device Mode

Use this feature to select the desired mode for a serial port specified. The options are **Normal** and High Speed.

## ► Serial Port Console Redirection

### COM

This submenu allows the user to configure the following Console Redirection settings for this Port.

### Console Redirection

Select Enabled to use the SOL Port for Console Redirection. The options are Enabled and **Disabled**.

### SOL

This submenu allows the user to configure the following Console Redirection settings for the SOL Port specified by the user.

### Console Redirection

Select Enabled to use the SOL Port for Console Redirection. The options are **Enabled** and Disabled.

## ► Console Redirection Settings

This feature allows the user to specify how the host computer will exchange data with the client computer, which is the remote computer used by the user.

### Terminal Type

This feature allows the user to select the target terminal emulation type for Console Redirection. Select VT100 to use the ASCII Character set. Select VT100+ to add color and function key support. Select ANSI to use the Extended ASCII Character Set. Select VT-UTF8 to use UTF8 encoding to map Unicode characters into one or more bytes. The options are ANSI, VT100, **VT100+**, and VT-UTF8.

### Bits Per second

Use this feature to set the transmission speed for a serial port used in Console Redirection. Make sure that the same speed is used in the host computer and the client computer. A lower transmission speed may be required for long and busy lines. The options are 9600, 19200, 38400, 57600 and **115200** (bits per second).

### Data Bits

Use this feature to set the data transmission size for Console Redirection. The options are 7 Bits and **8 Bits**.

### Parity

A parity bit can be sent along with regular data bits to detect data transmission errors. Select Even if the parity bit is set to 0, and the number of 1's in data bits is even. Select Odd if the parity bit is set to 0, and the number of 1's in data bits is odd. Select None if you do not want to send a parity bit with your data bits in transmission. Select Mark to add a mark as a parity bit to be sent along with the data bits. Select Space to add a Space as a parity bit to be sent with your data bits. The options are **None**, Even, Odd, Mark and Space.

### Stop Bits

A stop bit indicates the end of a serial data packet. Select 1 Stop Bit for standard serial data communication. Select 2 Stop Bits if slower devices are used. The options are **1** and **2**.

### Flow Control

This feature allows the user to set the flow control for Console Redirection to prevent data loss caused by buffer overflow. Send a "Stop" signal to stop sending data when the receiving buffer is full. Send a "Start" signal to start sending data when the receiving buffer is empty. The options are **None** and Hardware RTS/CTS.

**VT-UTF8 Combo Key Support**

Select Enabled to enable VT-UTF8 Combination Key support for ANSI/VT100 terminals. The options are **Enabled** and Disabled.

**Recorder Mode**

Select Enabled to capture the data displayed on a terminal and send it as text messages to a remote server. The options are **Disabled** and Enabled.

**Resolution 100x31**

Select Enabled for extended-terminal resolution support. The options are Disabled and **Enabled**.

**Legacy OS Redirection Resolution**

Use this feature to select the number of rows and columns used in Console Redirection for legacy OS support. The options are 80x24 and **80x25**.

**Putty KeyPad**

This feature selects Function Keys and KeyPad settings for Putty, which is a terminal emulator designed for the Windows OS. The options are **VT100**, LINUX, XTERMR6, SCO, ESCN, and VT400.

**Redirection After BIOS Post**

Use this feature to enable or disable legacy console redirection after BIOS POST. When set to Bootloader, legacy console redirection is disabled before booting the OS. When set to Always Enable, legacy console redirection remains enabled when booting the OS. The options are **Always Enable** and Bootloader.

**Serial Port for Out-of-Band Management/Windows Emergency Management Services (EMS)**

The submenu allows the user to configure Console Redirection settings to support Out-of-Band Serial Port management.

**Console Redirection (for EMS)**

Select Enabled to use a COM Port selected by the user for Console Redirection. The options are Enabled and **Disabled**.

## ► Console Redirection Settings (for EMS)

This feature allows the user to specify how the host computer will exchange data with the client computer, which is the remote computer used by the user.

### **Out-of-Band Management Port**

The feature selects a serial port used by the Microsoft Windows Emergency Management Services (EMS) to communicate with a remote server. The options are **COM** and SOL.

### **Terminal Type**

This feature allows the user to select the target terminal emulation type for Console Redirection. Select VT100 to use the ASCII character set. Select VT100+ to add color and function key support. Select ANSI to use the extended ASCII character set. Select VT-UTF8 to use UTF8 encoding to map Unicode characters into one or more bytes. The options are ANSI, VT100, **VT100+**, and VT-UTF8.

### **Bits Per Second**

This item sets the transmission speed for a serial port used in Console Redirection. Make sure that the same speed is used in the host computer and the client computer. A lower transmission speed may be required for long and busy lines. The options are 9600, 19200, 57600, and **115200** (bits per second).

### **Flow Control**

This feature allows the user to set the flow control for Console Redirection to prevent data loss caused by buffer overflow. Send a "Stop" signal to stop sending data when the receiving buffer is full. Send a "Start" signal to start sending data when the receiving buffer is empty. The options are **None**, Hardware RTS/CTS, and Software Xon/Xoff.

### **Data Bits, Parity, Stop Bits**

The setting for each these features is displayed.

## ► ACPI Settings

Use this feature to configure Advanced Configuration and Power Interface (ACPI) power management settings for your system.

### ACPI Sleep State

Use this feature to select the ACPI State when the system is in sleep mode. Select S1 (CPU Stop Clock) to erase all CPU caches and stop executing instructions. Power to the CPU(s) and RAM is maintained, but RAM is refreshed. Select Suspend Disabled to use power-reduced mode. Power will only be supplied to limited components (such as RAMs) to maintain the most critical functions of the system. The options are **S1 (CPU Stop Clock)** and Suspend Disabled.

### NUMA (NON-Uniform Memory Access)

This feature enables the Non-Uniform Memory Access ACPI support. The options are **Enabled** and Disabled.

### High Precision Event Timer

Select Enabled to activate the High Precision Event Timer (HPET) that produces periodic interrupts at a much higher frequency than a Real-time Clock (RTC) does in synchronizing multimedia streams, providing smooth playback, reducing the dependency on other timestamp calculation devices, such as an x86 RDTSC Instruction embedded in the CPU. The High Performance Event Timer is used to replace the 8254 Programmable Interval Timer. The options are **Enabled** and Disabled.

## ► Trusted Computing (Available when a TPM device is detected by the BIOS)

### Configuration

#### TPM Support

Select Enabled on this item and enable the TPM jumper on the serverboard to enable TPM support to improve data integrity and network security. The options are **Enabled** and Disabled.

#### TPM State

Select Enabled to enable TPM security settings to improve data integrity and network security. The options are Disabled and **Enabled**.

#### Pending Operation

Use this item to schedule an operation for the security device. The options are **None**, Enable Take Ownership, Disable Take Ownership, and TPM Clear.

**Note:** During restart, the computer will reboot in order to execute the pending operation and change the state of the security device.

### Current Status Information

This item displays the information regarding the current TPM status.

#### TPM Enable Status

This item displays the status of TPM Support to indicate if TPM is currently enabled or disabled.

#### TPM Active Status

This item displays the status of TPM Support to indicate if TPM is currently active or deactivated.

#### TPM Owner Status

This item displays the status of TPM Ownership.

## ► Intel TXT (LT-SX) Configuration

### Intel TXT (LT-SX) Hardware Support

This feature indicates if the following hardware components support the Intel Trusted Execution Technology.

#### CPU

TXT (Trusted Execution Technology) Feature

#### Chipset

TXT (Trusted Execution Technology) Feature

### Intel TXT (LT-SX) Configuration

This feature displays the following TXT configuration setting.

#### TXT (LT-SX) Support

This item indicates if the Intel TXT support is enabled or disabled. The default setting is **Disabled**.

### Intel TXT (LT-SX) Dependencies

This feature displays the features that need to be enabled for the Intel Trusted Execution Technology to work properly in the system.

#### VT-d Support

Intel Virtualization Technology with Direct I/O support

#### VT Support

Intel Virtualization Technology support

#### TPM Support

Trusted Platform support

#### TPM State

Trusted Platform state

## ► ME Subsystem

This feature displays the following ME Subsystem Configuration settings.

- ME BIOS Interface Version
- ME Version

## iSCSI Configuration

This item displays iSCSI configuration information:

### iSCSI Initiator Name

This item displays the name of the iSCSI Initiator, which is a unique name used in the world. The name must use IQN format. The following actions can also be performed:

- Add an Attempt
- Delete Attempts
  - Commit Changes and Exit
  - Discard Changes and Exit
- Change Attempt Order
  - Commit Changes and Exit
  - Discard Changes and Exit

## Intel® I350 Gigabit Network Connections

These items display the following information on the Intel I350 LAN connections.

## ► NIC Configuration

### Link Speed

Use this feature to change the link speed and duplex for the current port. The options are **AutoNeg**, 10Mbps Half, 10Mbps Full, 100Mbps Half, and 100Mbps full.

### Wake on LAN

Select enabled to wake the system with a magic packet. The options are **Enabled** and Disabled.

### Blink LEDs

This feature allows the user to specify the duration for LEDs to blink. The range is from 0 ~ 15 seconds. The default setting is **0**.

## PORT CONFIGURATION INFORMATION

This section displays the following port information:

- UEFI Driver
- Adapter PBA
- Chip Type
- PCI Device ID
- PCI Bus:Device:Function
- Link Status
- Factory MAC Address
- Alternate MAC Address

## 7-4 Event Logs

Select the Event Logs tab to access the following submenu items.

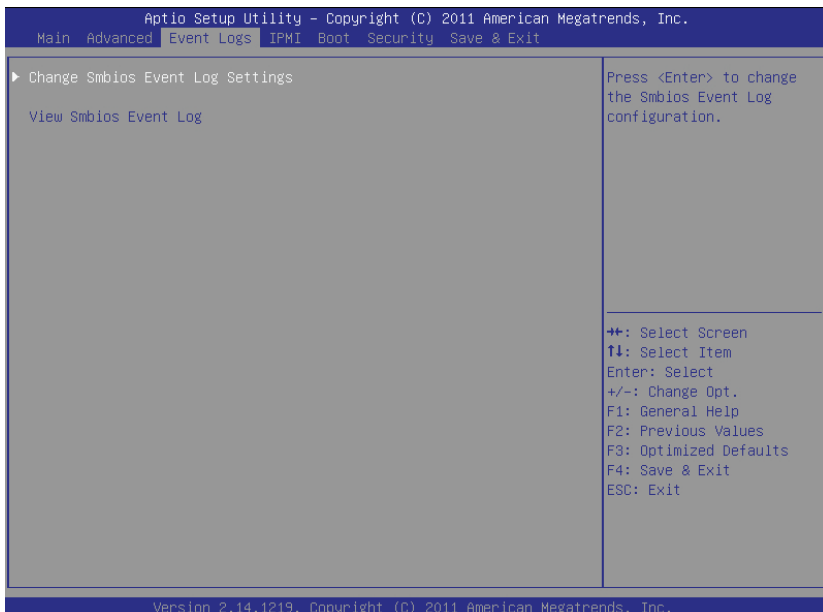

### ►Change SMBIOS Event Log Settings

This feature allows the user to configure SMBIOS Event settings.

#### Enabling/Disabling Options

##### SMBIOS Event Log

Select Enabled to enable SMBIOS (System Management BIOS) Event Logging during system boot. The options are **Enabled** and Disabled.

##### Runtime Error Logging Support

Select Enabled to support Runtime Error Logging. The options are **Enabled** and Disabled.

##### Memory Correctable Error Threshold

This feature allows the user to enter the threshold value for correctable memory errors. The default setting is **10**.

### **PCI Error Logging Support**

Select Enabled to support error event logging for PCI slots. The options are Enabled and **Disabled**.

### **Erasing Settings**

#### **Erase Event Log**

Select Enabled to erase the SMBIOS (System Management BIOS) Event Log, which is completed before a event logging is initialized upon system reboot. The options are **No**, Yes, Next reset, and Yes, Every reset.

#### **When Log is Full**

Select Erase Immediately to immediately erase SMBIOS error event logs that exceed the limit when the SMBIOS event log is full. Select Do Nothing for the system to do nothing when the SMBIOS event log is full. The options are **Do Nothing** and Erase Immediately.

### **SMBIOS Event Log Standard Settings**

#### **Log System Boot Event**

Select Enabled to log system boot events. The options are **Disabled** and Enabled.

#### **MECI (Multiple Event Count Increment)**

Enter the increment value for the multiple event counter. Enter a number from 1 to 255. The default setting is **1**.

#### **METW (Multiple Event Count Time Window)**

This item allows the user to decide how long (in minutes) should the multiple event counter wait before generating a new event log. Enter a number from 0 to 99. The default setting is **60**.

#### **View SMBIOS Event Log**

This item allows the user to view the event in the SMBIOS event log. Select this item and press <Enter> to view the status of an event in the log. The following categories are displayed:

Date/Time/Error Code/Severity

## 7-5 IPMI

Select the IPMI (Intelligent Platform Management Interface) tab to access the following submenu items.



### IPMI Firmware Revision, IPMI Status

These items indicate your system IPMI firmware revision number and status.

### ▶ System Event Log

#### SEL Components

Select Enabled for all system event logging at bootup. The options are **Enabled** and Disabled.

#### Erase Settings

##### Erase SEL

Select Yes, On next reset to erase all system event logs upon next system reboot.  
 Select Yes, On every reset to erase all system event logs upon each system reboot.  
 Select No to keep all system event logs after each system reboot. The options are **No**, Yes, On next reset, and Yes, On every reset.

### When SEL is Full

This feature allows the user to decide what the BIOS should do when the system event log is full. Select Erase Immediately to erase all events in the log when the system event log is full. The options are **Do Nothing** and Erase Immediately.

### Custom EFI Logging Options

#### Log EFI Status Codes

Select Enabled to log EFI (Extensible Firmware Interface) Status Codes, Error Codes or Progress Codes. The options are Enabled and **Disabled**.

**Note:** After making changes on a setting, be sure to reboot the system for the changes to take effect.

## ►BMC Network Configuration

### LAN Channel 1

This feature allows the user to configure the settings for LAN1 Port.

#### Update IPMI LAN Configuration

This feature allows the BIOS to implement any IP/MAC address changes at the next system boot. If the option is set to Yes, any changes made to the settings below will take effect when the system is rebooted. The options are **No** and Yes.

#### Configuration Address Source

This feature allows the user to select the source of the IP address for this computer. If Static is selected, you will need to know the IP address of this computer and enter it to the system manually in the field. If DHCP is selected, the BIOS will search for a DHCP (Dynamic Host Configuration Protocol) server in the network that is attached to and request the next available IP address for this computer. The options are **DHCP** and Static. The following items are assigned IP addresses automatically if DHCP is selected, or can be configured manually if Static is selected.

#### Station IP Address

This item displays the Station IP address for this computer. This should be in decimal and in dotted quad form (i.e., 192.168.10.253).

#### Subnet Mask

This item displays the sub-network that this computer belongs to. The value of each three-digit number separated by dots should not exceed 255.

### Station MAC Address

This item displays the Station MAC address for this computer. Mac addresses are 6 two-digit hexadecimal numbers.

### Gateway IP Address

This item displays the Gateway IP address for this computer. This should be in decimal and in dotted quad form (i.e., 192.168.10.253).

## 7-6 Boot

This submenu allows the user to configure the following boot settings for the system.

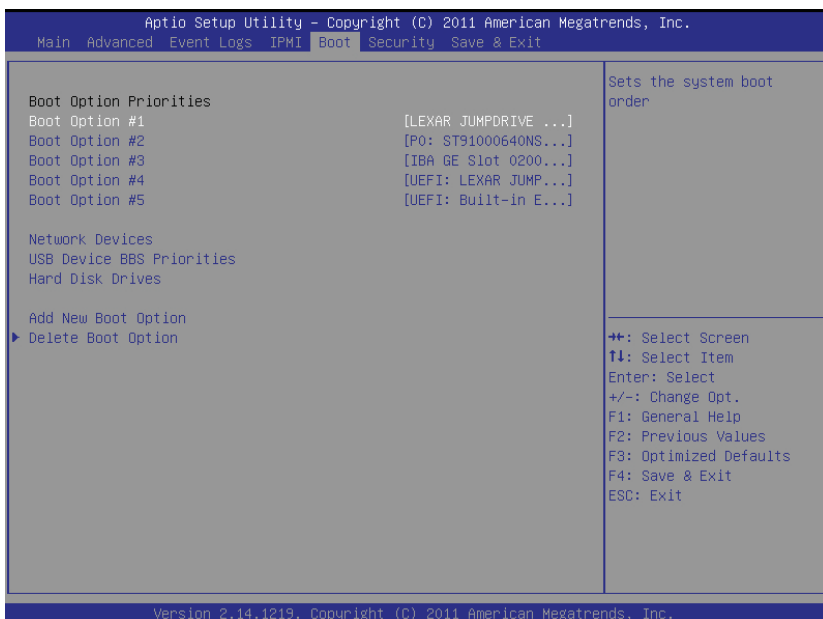

### Boot Option Priorities

#### Boot Option #1/ Boot Option #2/ Boot Option #3, etc.

Use this feature to specify the sequence of boot device priority.

#### Network Devices, Hard Disk Drives

The above options appear when detected by the BIOS. Use these options to set the order of the legacy network and Hard Disk Drive devices detected by the serverboard.

## Add New Boot Option

This feature allows the user to add a new EFI boot device to the boot priority list.

### ►Delete Boot Option

This feature allows the user to select a EFI boot device to delete from the boot priority list.

## Delete Boot Option

Select the desired boot device to delete.

## 7-7 Security

This menu allows the user to configure the following security settings for the system.

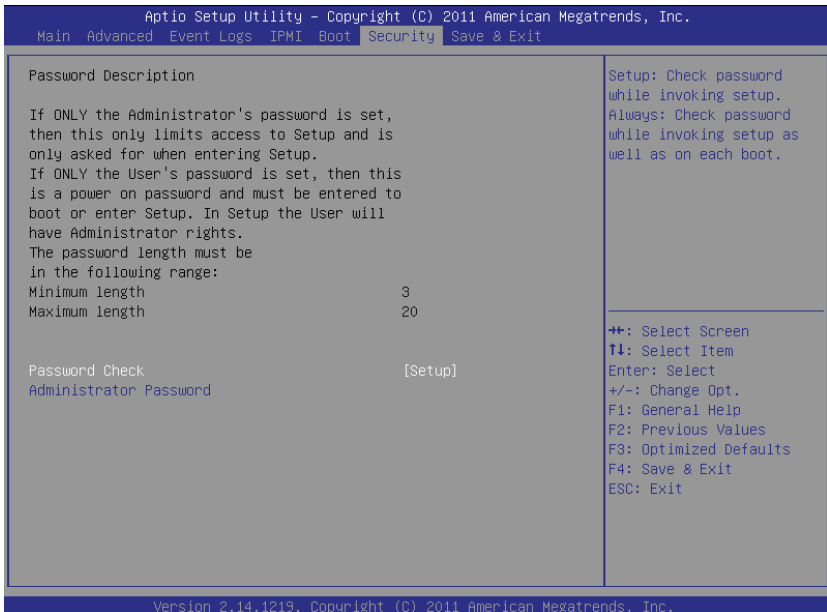

## Password Check

Use this feature to determine when a password entry is required. Select Setup to require the password only when entering setup. Select Always to require the password when entering setup and on each boot. The options are **Setup** and **Always**.

## Administrator Password

Use this feature to set the Administrator Password which is required to enter the BIOS setup utility. The length of the password should be from 3 characters to 20 characters long.

## 7-8 Save & Exit

This submenu allows the user to configure the Save and Exit settings for the system.

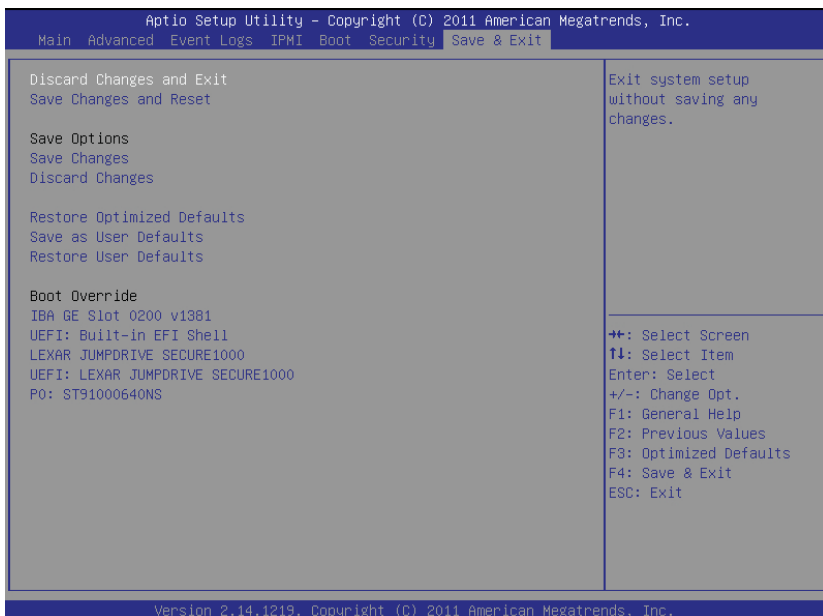

### Discard Changes and Exit

Select this option to quit the BIOS Setup without making any permanent changes to the system configuration, and reboot the computer. Select Discard Changes and Exit, and press <Enter>. When the dialog box appears, asking you if you want to exit the BIOS setup without saving, select **Yes** to quit BIOS without saving the changes, or select No to quit the BIOS and save changes.

## Save Changes and Reset

When you have completed the system configuration changes, select this option to save the changes and reboot the computer so that the new system configuration settings can take effect. Select Save Changes and Exit, and press <Enter>. When the dialog box appears, asking you if you want to exit the BIOS setup without saving, select **Yes** to quit BIOS without saving the changes, or select No to quit the BIOS and save changes.

## Save Options

### Save Changes

Select this option and press <Enter> to save all changes you've done so far and return to the AMI BIOS utility Program. When the dialog box appears, asking you if you want to save configuration, select **Yes** to save the changes, or select No to return to the BIOS without making changes.

### Discard Changes

Select this feature and press <Enter> to discard all the changes and return to the BIOS setup. When the dialog box appears, asking you if you want to load previous values, select **Yes** to load the values previous saved, or select No to keep the changes you've made so far.

### Restore Optimized Defaults

Select this feature and press <Enter> to load the optimized default settings that help optimize system performance. When the dialog box appears, asking you if you want to load optimized defaults, select **Yes** to load the optimized default settings, or select No to abandon optimized defaults.

### Save as User Defaults

Select this feature and press <Enter> to save the current settings as the user's defaults. When the dialog box appears, asking you if you want to save values as user's defaults, select **Yes** to save the current values as user's default settings, or select No to keep the defaults previously saved as the user's defaults.

### Restore User Defaults

Select this feature and press <Enter> to load the user's defaults previously saved in the system. When the dialog box appears, asking you if you want to restore user's defaults, select **Yes** to restore the user's defaults previously saved in the system, or select No to abandon the user's defaults that were previously saved.

### **Boot Override**

This feature allows the user to override the Boot Option Priorities setting in the Boot menu, and instead immediately boot the system with one of the listed devices. This is a one-time override.

## Appendix A

### BIOS Error Beep Codes

During the POST (Power-On Self-Test) routines, which are performed each time the system is powered on, errors may occur.

**Non-fatal errors** are those which, in most cases, allow the system to continue the boot-up process. The error messages normally appear on the screen.

**Fatal errors** are those which will not allow the system to continue the boot-up procedure. If a fatal error occurs, you should consult with your system manufacturer for possible repairs.

These fatal errors are usually communicated through a series of audible beeps. The numbers on the fatal error list (on the following page) correspond to the number of beeps for the corresponding error. All errors listed, with the exception of Beep Code 8, are fatal errors.

#### A-1 AMIBIOS Error Beep Codes

Beep Code	Error Message	Description
1 beep	Refresh	Circuits have been reset (Ready to power up)
5 short beeps and 1 long beep	Memory error	No memory detected in the system
5 long and 2 short beeps	Display memory read/write error	Video adapter missing or with faulty memory
1 continuous beep	System overheat	System overheat

# Notes

# Appendix B

## System Specifications

**Note:** Unless noted specifications apply to a complete system (all serverboards).

### Processors

Two E5-2600 series processors per node in Socket R LGA 2011 type sockets

**Note:** please refer to our website for details on supported processors.

### Chipset

One C602 chipset per node

### BIOS

128 MB AMI BIOS® Flash EEPROM per node

### Memory Capacity

The X9DRT-IBQF/IBFF/F has eight (8) DIMM slots supporting up to 256 GB of DDR3-1600/1333/1066/800 MHz speed RDIMM/LDIMM registered ECC or 64 GB of DDR3-1600/1333/1066/800 MHz speed UDIMM SDRAM in up to 512 MB, 1 GB, 2 GB, 4 GB, 8 GB, 16 GB or 32 GB sizes at 1.35V or 1.5V voltages.

**Note:** refer to Section 5-6 for details on installation.

**Note:** Check the Supermicro website ([www.supermicro.com](http://www.supermicro.com)) for the latest memory support information.

### SATA Drive Bays

The SuperServer 6017TR-TQF/TFF/TF contains four (4) hot-swap drive bays to house twelve standard SATA drives, two per node.

### PCI Expansion

The SuperServer 6017TR-TQF/TFF/TF has one (1) PCI Express 3.0 x16 slot available per node.

### Serverboard

X9DRT-IBQF/IBFF/F serverboard (proprietary form factor)

Dimensions: (LxW) 6.5 x 16.64 in. (165.1 x 422.66 mm)

## Chassis

SC808BT-1K28BP (1U rackmount)

Dimensions: (WxHxD) 17.2 x 1.7 x 27.75 in. (437 x 43 x 705 mm)

## Weight

Gross (Bare Bone): 39 lbs. (17.7 kg.)

## System Cooling

The system has six (6) 4-cm PWM system cooling fans

## System Input Requirements

AC Input Voltage: 85-264V AC auto-range

Rated Input Current: 15 - 5A

Rated Input Frequency: 47 to 63 Hz

Efficiency: 90+ (Platinum Level)

## Power Supply

Rated Output Power: 1280 Watt (Part# PWS-1K28P-SQ)

Rated Output Voltages: +12V (135A@180-264V, 100A@120-140V), +5Vsb (6A)

## Operating Environment

Operating Temperature: 0° to 35° C (32° to 95° F)

Non-operating Temperature: -40° to 70° C (-40° to 158° F)

Operating Relative Humidity: 20% to 95% (non-condensing)

Non-operating Relative Humidity: 5 to 95% (non-condensing)

## Regulatory Compliance

Electromagnetic Emissions: FCC Class A, EN 55022 Class A, EN 61000-3-2/-3-3, CISPR 22 Class A

Electromagnetic Immunity: EN 55024/CISPR 24, (EN 61000-4-2, EN 61000-4-3, EN 61000-4-4, EN 61000-4-5, EN 61000-4-6, EN 61000-4-8, EN 61000-4-11)

Safety: CSA/EN/IEC/UL 60950-1 Compliant, UL or CSA Listed (USA and Canada), CE Marking (Europe)

California Best Management Practices Regulations for Perchlorate Materials:  
This Perchlorate warning applies only to products containing CR (Manganese Dioxide) Lithium coin cells. "Perchlorate Material-special handling may apply. See [www.dtsc.ca.gov/hazardouswaste/perchlorate](http://www.dtsc.ca.gov/hazardouswaste/perchlorate)" for further details.

## Notes

(continued from front)

The products sold by Supermicro are not intended for and will not be used in life support systems, medical equipment, nuclear facilities or systems, aircraft, aircraft devices, aircraft/emergency communication devices or other critical systems whose failure to perform be reasonably expected to result in significant injury or loss of life or catastrophic property damage. Accordingly, Supermicro disclaims any and all liability, and should buyer use or sell such products for use in such ultra-hazardous applications, it does so entirely at its own risk. Furthermore, buyer agrees to fully indemnify, defend and hold Supermicro harmless for and against any and all claims, demands, actions, litigation, and proceedings of any kind arising out of or related to such ultra-hazardous use or sale.