

# Motherboard Components

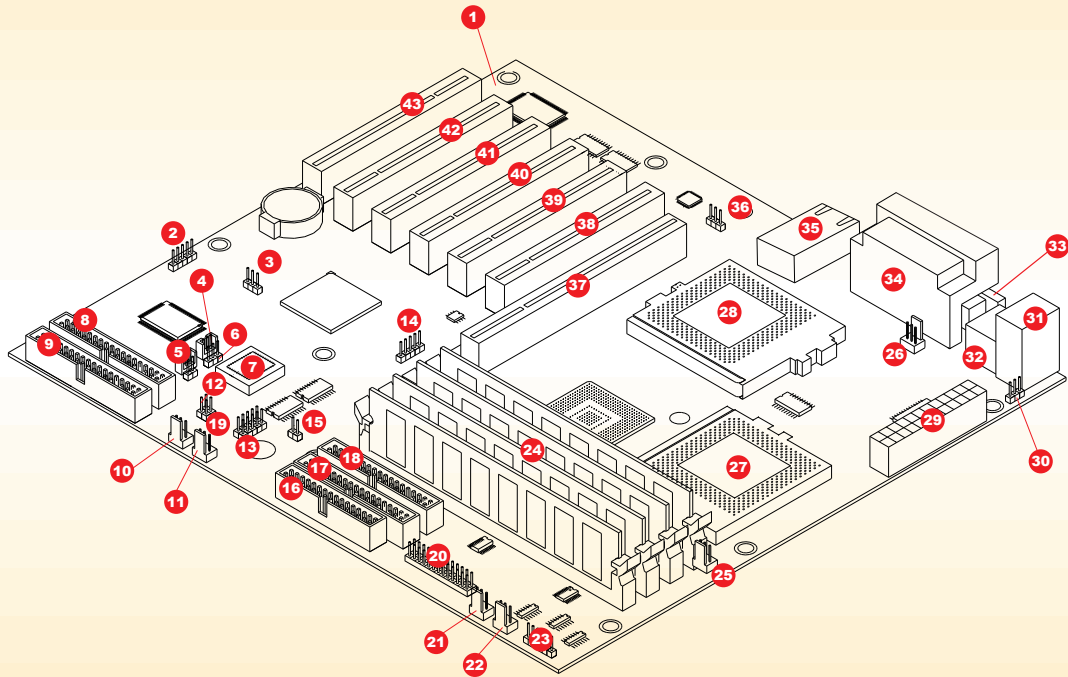

1 System Board	14 JP8: I2C	27 CPU#1
2 J18	15 JP7	28 CPU#2
3 JBT1	16 Floppy Connector	29 J10: 24-pin ATX PWR Conn.
4 WOL1	17 IDE #2	30 JP2: JPWAKE
5 WOM1	18 IDE #1	31 Mouse and Keyboard Connectors
6 J17	19 JP6	32 USB1, USB2
7 BIOS	20 JF1, JP9: Front Control Panel Conn.	33 COM 1, COM 2
8 IDE RAID #1	21 CPU1 Chassis Fan	34 Printer Port
9 IDE RAID #2	22 Chassis Fan 1/0 H	35 LAN1
10 Chassis Fan2	23 J19: 6-pin Power Conn.	36 JPL1L
11 CPU2 Chassis Fan	24 DIMM 0,1,2,3	37 4xAGP Pro
12 JL1	25 CPU1 Fan	38,39,40,41,42 32-bit PCI
13 USB3,USB4	26 CPU2 Fan	43 ACR

## Front Panel Functions

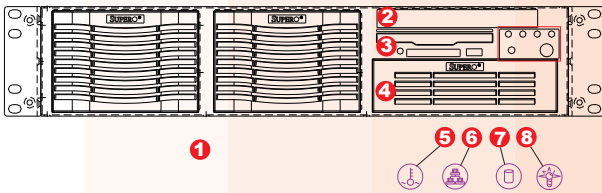

1. 6 x 3.5" IDE drive bays
2. 1 Slim CD-ROM (optional)
3. 1 x Floppy Drive
4. 1 x 5.25" drive bay
5. Overheat: Indicates an overheat condition in the system
6. NIC1: Indicates network activity on LAN1 when flashing
7. HDD: Indicates IDE channel activity.
8. Power: Indicates power is being supplied to the system's power supply units

## P3TDDE Quick Reference

Jumper	Description	Default Setting
JBT1 <input type="checkbox"/>	CMOS Clear	Pin 1-2 (Normal)
JPWAKE	Keyboard Wake-Up	Pin 1-2 (Disabled)
JPL1	LAN Enable/Disable	Pin 1-2 (Enabled)
JP7 <input type="checkbox"/>	CPU/Chassis Fan RPM Detection	Pin 1-2 (Disabled)
JP6 <input type="checkbox"/>	OH/Chassis Fan	Pin 1-2 (Over Heat)
J17	Onboard IDE RAID	Pin 1-2 (Enabled)
	Onboard IDE RAID	Pin 2-3 (Disabled)

## Rear Panel Functions

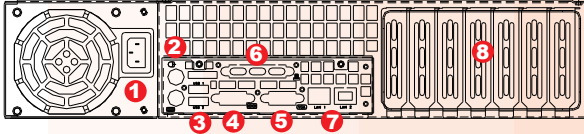

1. AC Power connector
2. PS/2 Mouse and Keyboard port
3. 2 USB ports
4. COM 1
5. COM 2
6. 1 Parallel port
7. 1 Intel 82559 LAN port
8. 7 Low-Profile 64/32-bit Expansion slot

## Installing 5.25" Drive Bay Rail

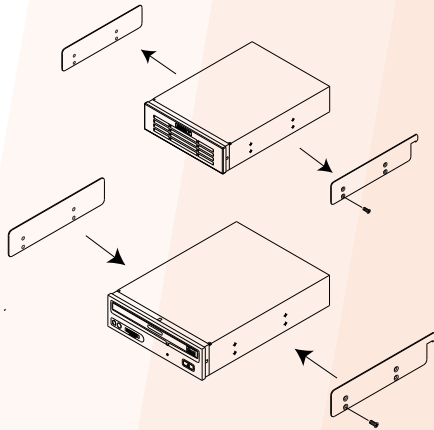

Remove the drive bay cover by pressing the tab. Install the rails onto the new component and then the new component into the drive bay until you hear a clicking sound from the tab.

## Cooling Fan Installation

### Warning !

#### CPU Heat Sink Installation Procedures (For Supermicro SuperServer 2U Systems)

Due to the fact that adequate air flow and proper thermal control are very critical in maintaining 2U system's stability and performance, it is imperative that the proper installation procedures listed below be followed in order to maximize system performance. This is especially critical for 2U Dual Processor Servers with speeds of 1 GHz and above.

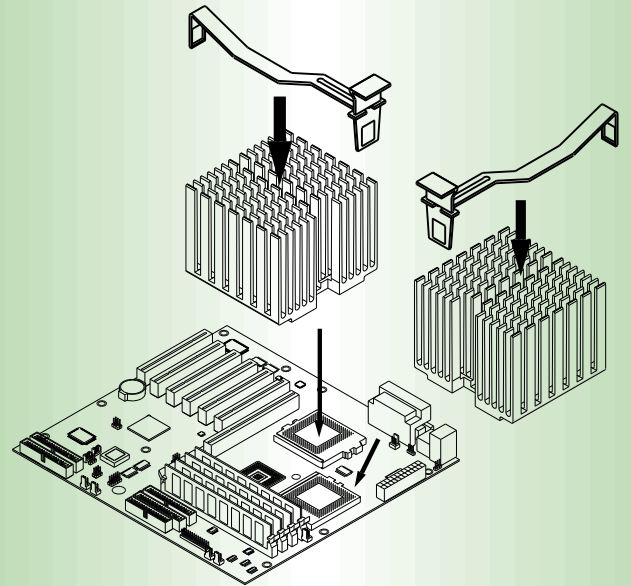

- 1) Only those CPU heat sinks that are provided by Supermicro should be used.
- 2) Apply a small amount of silicon compound on the CPU's die.
- 3) Place the CPU heat sink on top of the CPU.
- 4) Place the heat sink spring on top of the CPU heat sink and secure the clip of the spring into its notch.  
(Make sure the clip position is the same as the picture shown above.)

**SUPERMICRO**<sup>®</sup>  
[www.supermicro.com](http://www.supermicro.com)