

Information for Lot 9 of ErP (Ecodesign)

This addendum addresses European Union (EU) Ecodesign requirements for servers and storage products. All data and ratings within this addendum are in reference only to the Supermicro product(s) in the manual. The below information conforms to requirements laid down in Annex II of the Commission Regulation 2019/424.

- 3(1)(a): See Section 1.1 of the system manual for the product type.
- 3(1)(b): See the title page and preface of the system manual for the trademark and manufacturer's address.
- 3(1)(c): See the title page of the system manual for product model number(s).
- 3(1)(d): See the serial number on the physical system to determine the year of manufacture.
- 3(1)(e-j): **PSU Efficiency and Power Factor Value (Table) (From 80 Plus report)**

PSU Model #: PWS-2K04A-1R Watts: 2000W	PSU Efficiency				Power Factor
% of Rated Load	10 %	20 %	50 %	100 %	50 %
Single Output (AC-DC)	94.06%	95.75%	96.30%	93.84%	0.99

System (EUT) Efficiency in **Idle State** Power (Table)

Representative Configurations	Measured Idle State Power (W)	Calculated Idle Power Allowance (W)
High-End Performance Configuration	511.9	1032.9
Typical Configuration	N/A	N/A
Low-End Performance Configuration	343.8	847.2

System (EUT) Efficiency in **Active State** Power (Table)

Representative Configurations	Active State Efficiency Score (Effserver)	Minimum Active State Efficiency for 2-Socket Server
High-End Performance Configuration	73.1	8.0
Typical Configuration	N/A	
Low-End Performance Configuration	50.6	

3(1)(k): The operating condition class is **A2**.

Operating condition class	Dry bulb temp °C		Humidity range, non-condensing		Max dew point (°C)	Maximum rate of change (°C/hr)
	Allowable range	Recommended range	Allowable range	Recommended range		
A1	15- 32	18-27	- 12 °C Dew Point (DP) and 8 % relative humidity (RH) to 17 °C DP and 80 % RH	- 9 °C DP to 15 °C DP and 60 % RH	17	5/20
A2	10-35	18-27	- 12 °C DP and 8 % RH to 21 °C DP and 80 % RH	Same as A1	21	5/20
A3	5-40	18-27	- 12 °C DP and 8 % RH to 24 °C DP and 85 % RH	Same as A1	24	5/20
A4	5-45	18-27	- 12 °C DP and 8 % RH to 24 °C DP and 90 % RH	Same as A1	24	5/20

3(1)(l): The idle state power at the higher boundary temperature of the operating conditions class is 604W.

3(1)(m): The active state efficiency and performance is 73.1.

3(1)(n): There are two methods by which a user can securely delete data from this system. The user performing secure data deletion should be an IT professional.

The first is with a Unified Extensible Firmware Interface (UEFI) shell utility. This utility works on X10/X11/H11/H12/M11 motherboard series with onboard SATA/NVMe devices. Any user may access and download this utility through following link:

https://www.supermicro.com/about/policies/disclaimer.cfm?url=/wftp/utility/Lot9_Secure_Data_Deletion_Utility/

Download the shell utility package and extract it to a USB flash drive, then plug the drive into the server for which secure data deletion is necessary. Then turn the system on. Navigate to the BIOS setup menu, then place the server system into the UEFI shell environment. Follow the instructions in the README file to invoke the utility and complete the deletion.

The second method is through the secure data deletion tool provided by the original manufacturer of the hard drive. This should be used in a scenario where the shell utility is not applicable. Each manufacturer should have the tool available on their website. If needed, please look on the hard drive label for the name of the manufacturer and model information.

3(1)(o): List of recommended combinations of blade servers with chassis: N/A.

3(1)(p): List of all current SKUs within this product family: AS -2014TP-HTR.

3(3)(a): There is no use of cobalt in batteries in this product.

The indicative weight range of neodymium in the HDD is 0.0 if manufactured by Western Digital, and is between 5-25 grams if manufactured by Seagate.

3(3)(b):

Please see the disassembly instructions on the next page.

Illustrated System Disassembly Instructions

Please note: All the illustrations in the below disassembly instructions are for demonstration only. Components shown here may not match exactly with the components in your system.

CAUTION: Always power off the system and unplug the power cord(s) first before disassembling the system!

1. Data Storage Devices

Type and number of fastenings: One (1) latch and six (6) Phillips screws per drive.

Tools required: Screwdriver with PH2 bit.

Procedure:

1. Press the release button on the drive tray. This extends the drive bay handle.
2. Use the handle to pull the drive out of the chassis.
3. Remove the six screws on the drive tray to release the hard drive.

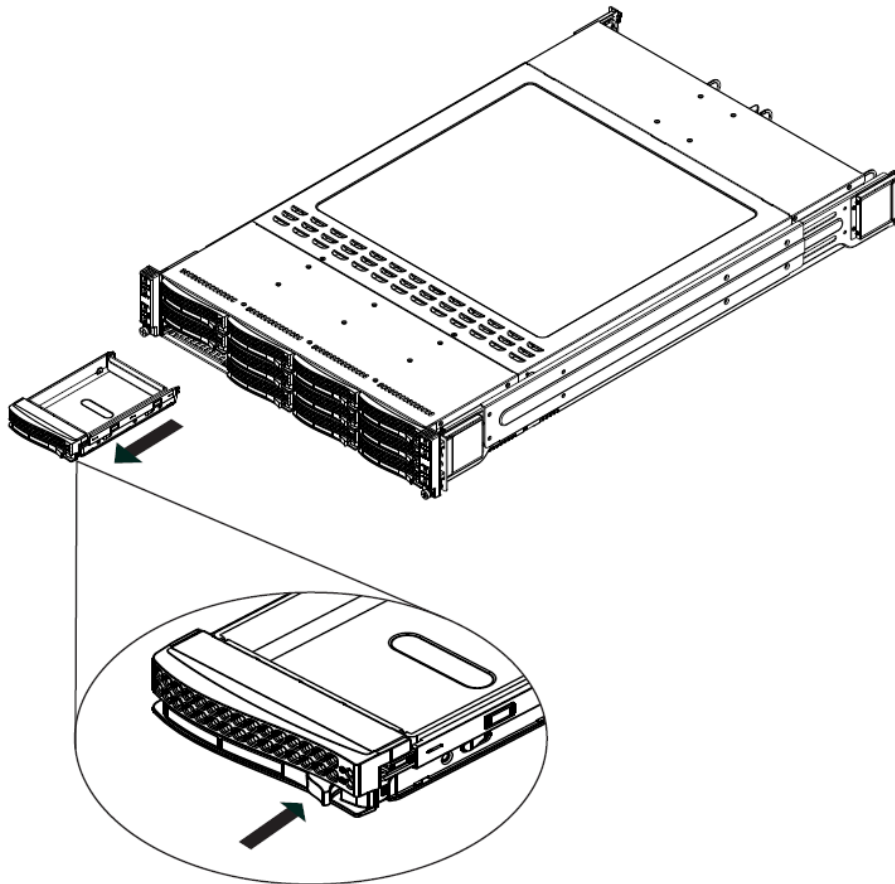

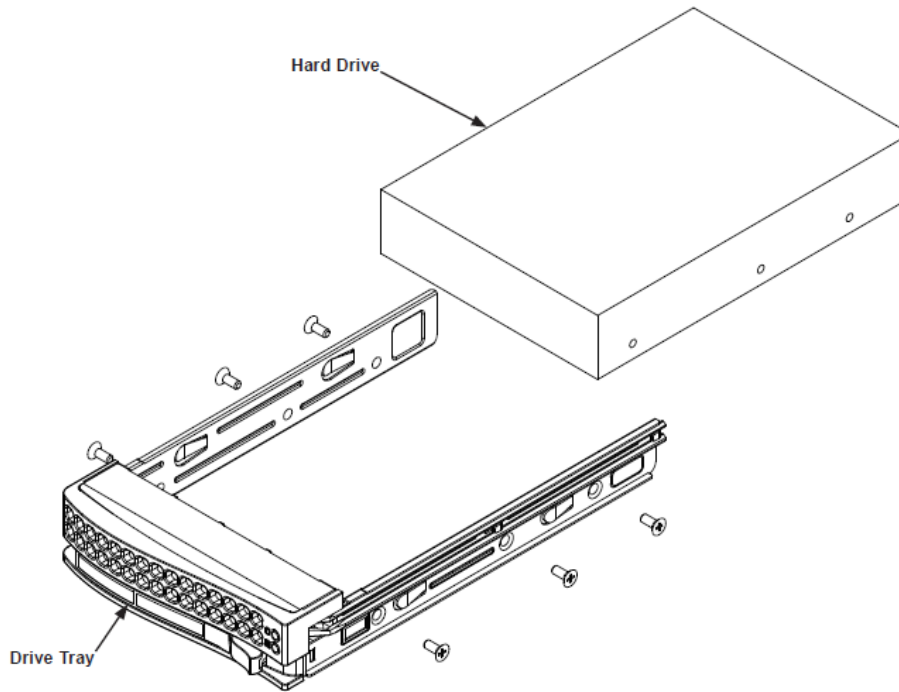

2. Memory

Type and number of fastenings: Two (2) latches per memory module.

Tools required: None.

Procedure:

1. Press both release tabs on the ends of the memory module to unlock it.
2. Once the module is loosened, remove it from the memory slot.

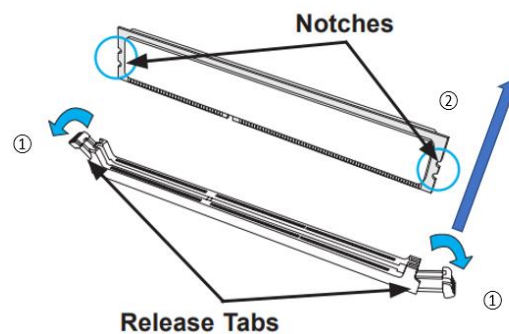

3. Air Shroud

Type and number of fastenings: Two (2) Phillips screws.

Tools required: Screwdriver with PH2 bit.

Procedure:

1. Remove the two screws holding the air shroud.
2. Pull the air shroud up and away from the motherboard.

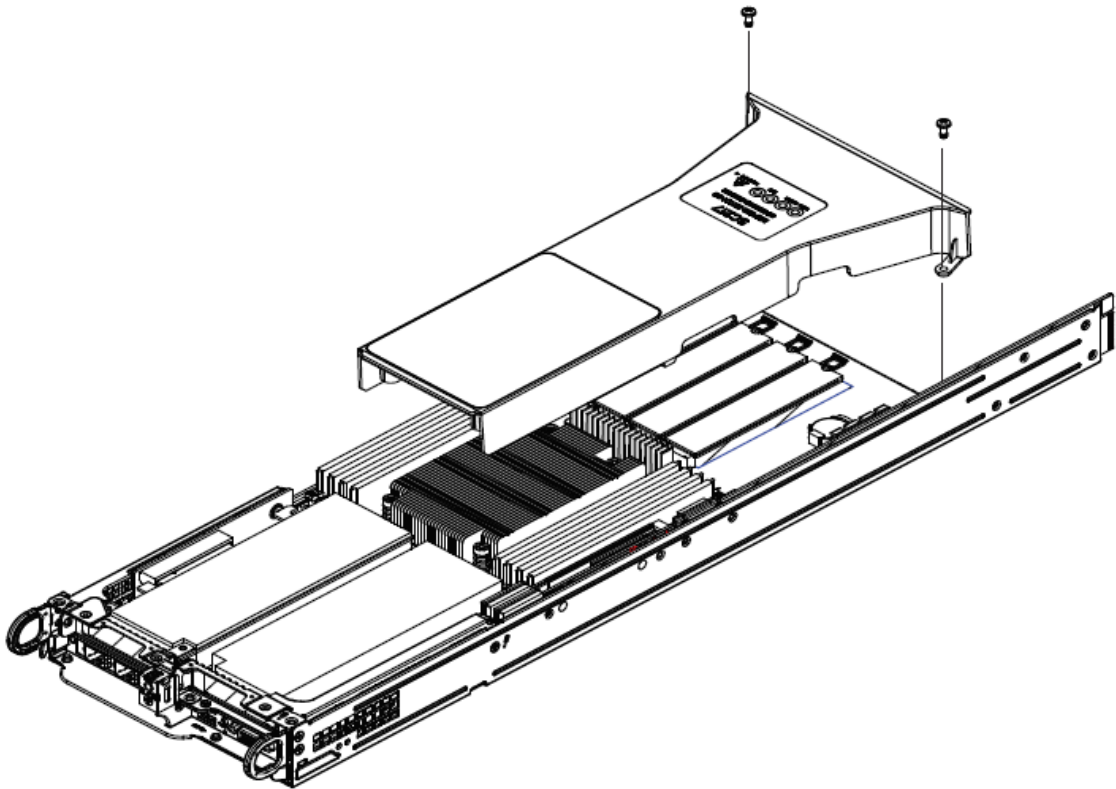

4. Processor

Type and number of fastenings: Four (4) T20 Torx screws.

Tools required: Screwdriver with T20 Torx bit.

Procedure: Remove the screws in the sequence of 4, then 3, then 2, then 1, as marked in the illustration below. After removing the screws, lift the processor heatsink module off the processor socket. Unscrew the processor socket frame in the sequence of 3, 2, and then 1. Flip the socket frame up. Lift up the rail frame and slide the processor out.

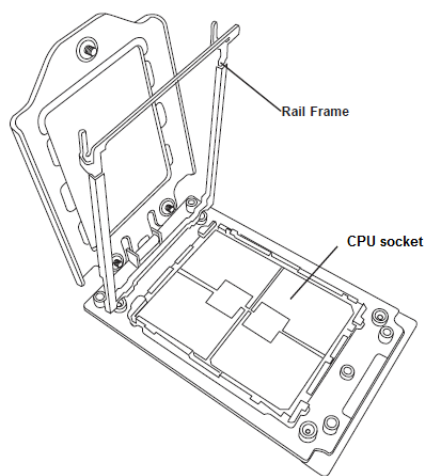
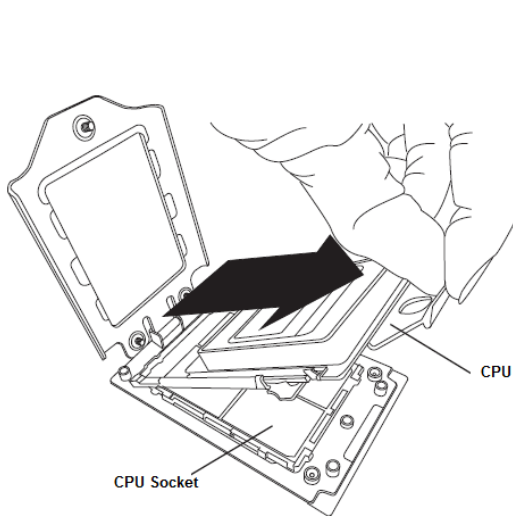
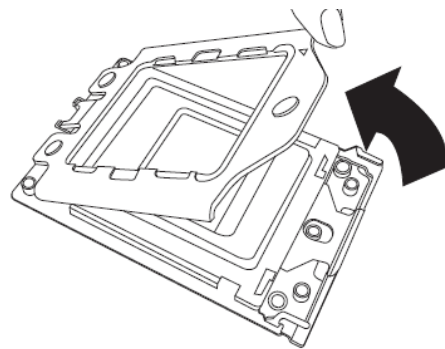
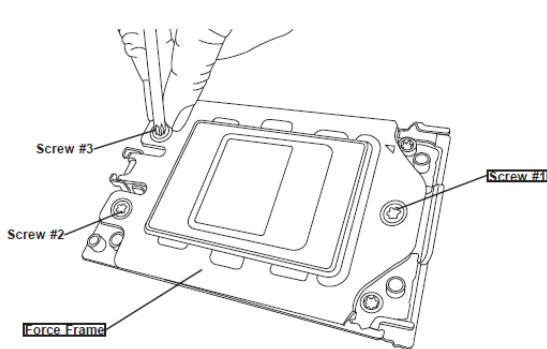
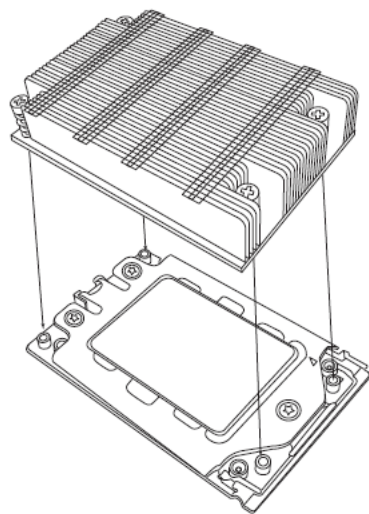
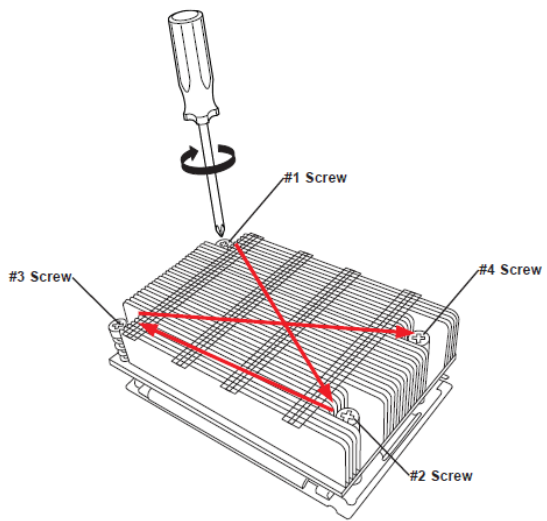

How the socket will look when CPU is removed

5. Adapter Card

Type and number of fastenings: Five (5) Phillips screws.

Tools required: Screwdriver with PH2 bit.

Procedure:

1. Remove the five screws securing the adapter card to the motherboard drawer.
2. Remove the adapter card from the motherboard drawer by carefully pulling up.

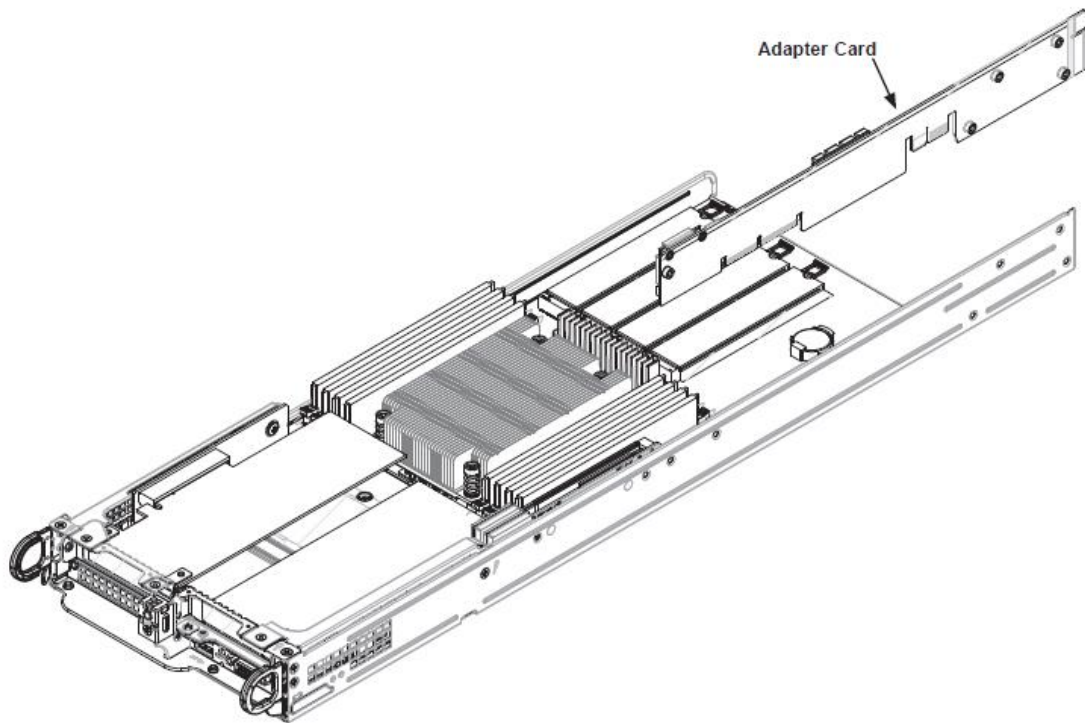

6. Riser Card

Type and number of fastenings: Five (5) Phillips screws.

Tools required: Screwdriver with PH2 bit.

Procedure:

1. Remove the node from the chassis by pulling on the pulling tabs.
2. Remove the screw at the center of the bracket.
3. Remove the two screws securing each riser card.
4. Lift the riser card out from the motherboard expansion slot.

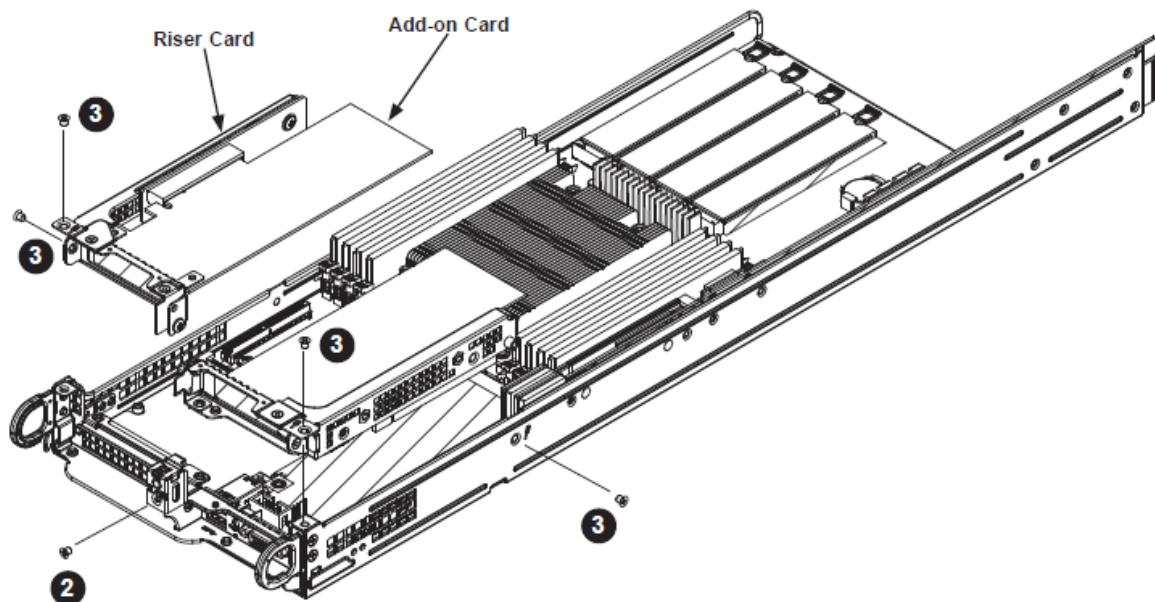

7. Expansion Card/Graphics Card

Type and number of fastenings: One (1) Phillips screw.

Tools required: Screwdriver with PH2 bit.

Procedure:

1. Remove the screw holding the add-on card
2. Carefully pull the add-on card out from the riser card.

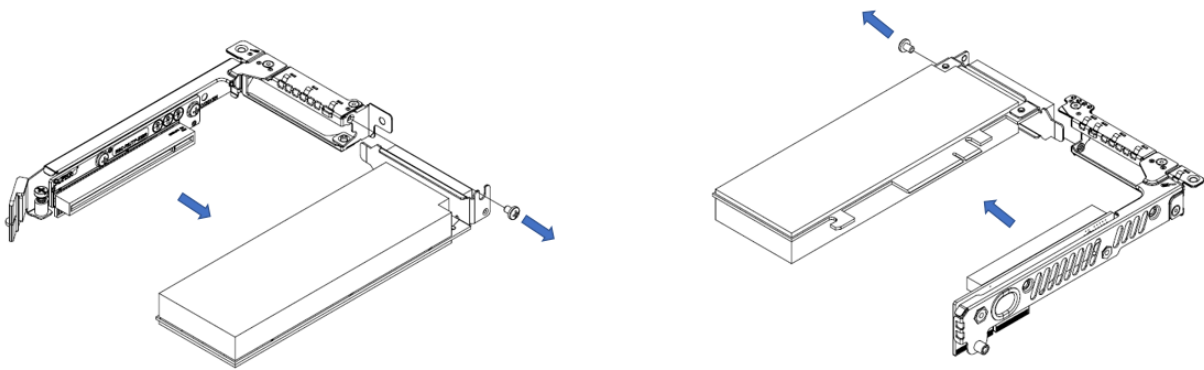

8. Power Supply Module

Type and number of fastenings: One (1) latch per module.

Tools required: None.

Procedure:

1. Unplug the power cord from the power supply.
2. Push the release tab on the back of the power supply module to the side and pull the module straight out.

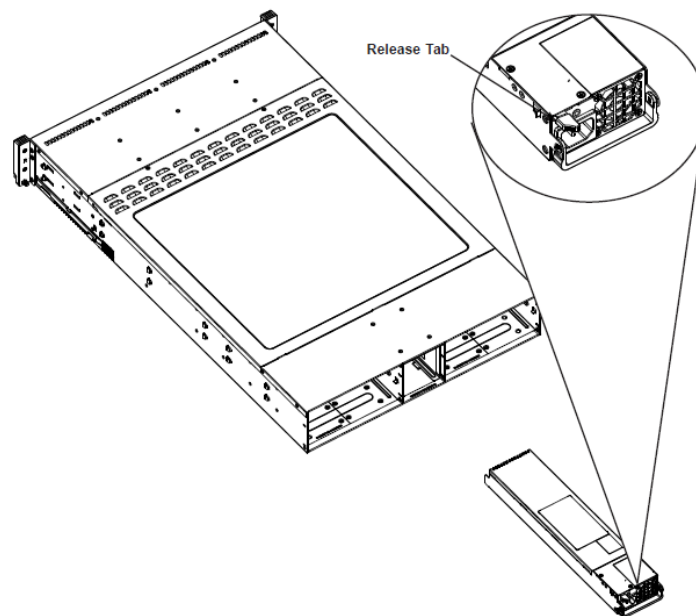

9. Chassis Cover

Type and number of fastenings: Two (2) Phillips screws.

Tools required: Screwdriver with PH2 bit.

Procedure:

1. Remove the two screws that secure the top cover onto the chassis as shown.
2. Lift the top cover up and off the chassis.

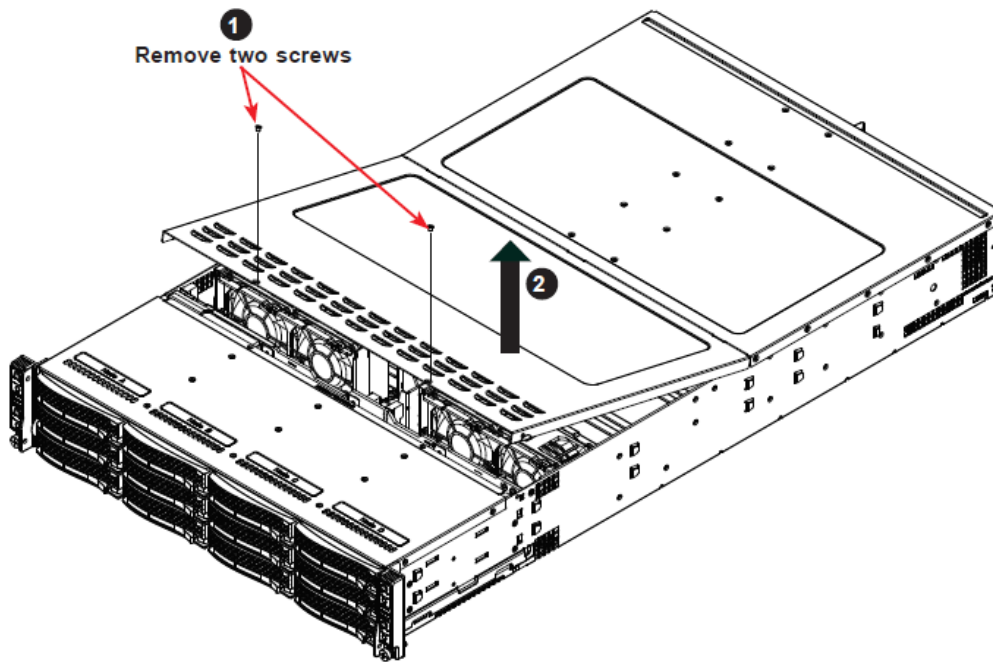

10. Batteries

Type and number of fastenings: One (1) latch.

Tools required: None.

Procedure: Push aside the small clamp that covers the edge of the battery. When the battery is released, lift it out of the holder.

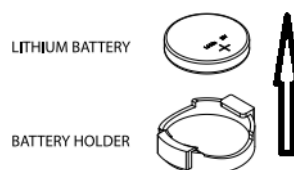

11. Fans

Type and number of fastenings: One (1) fan header per fan.

Tools required: None.

Procedure:

1. Disconnect the fan's power cord from the backplane.
2. Lift the fan housing out of the chassis.

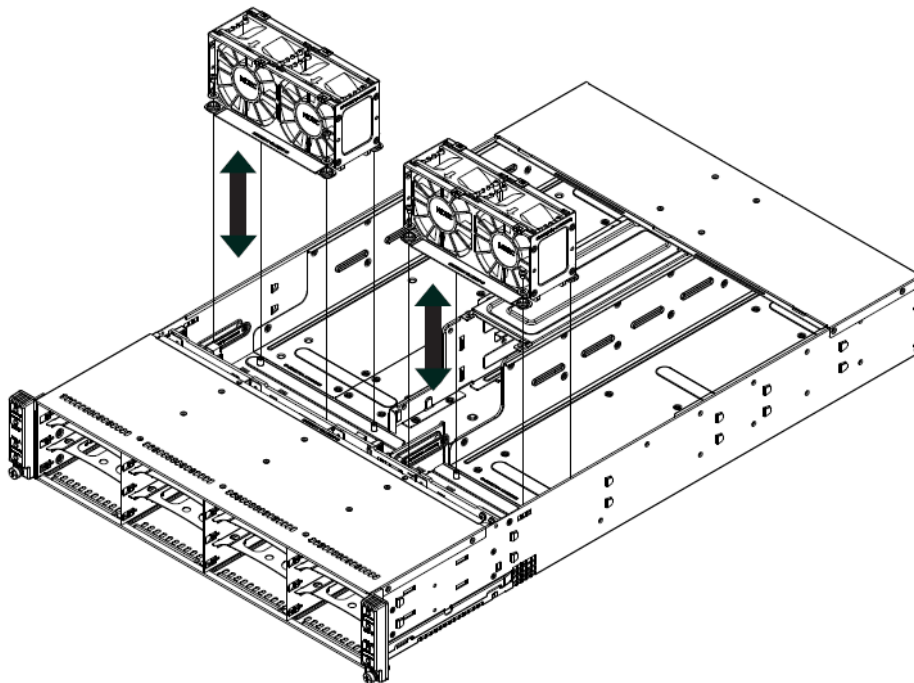

12. SIOM

Type and number of fastenings: Seven (7) Phillips screws.

Tools required: Screwdriver with PH2 bit.

Procedure:

1. Remove the two riser brackets first, as instructed in the riser card section.
2. Remove the seven screws securing the pulling bracket to the node.
3. Loosen the two screws holding the SIOM module and carefully disconnect the module from the motherboard.

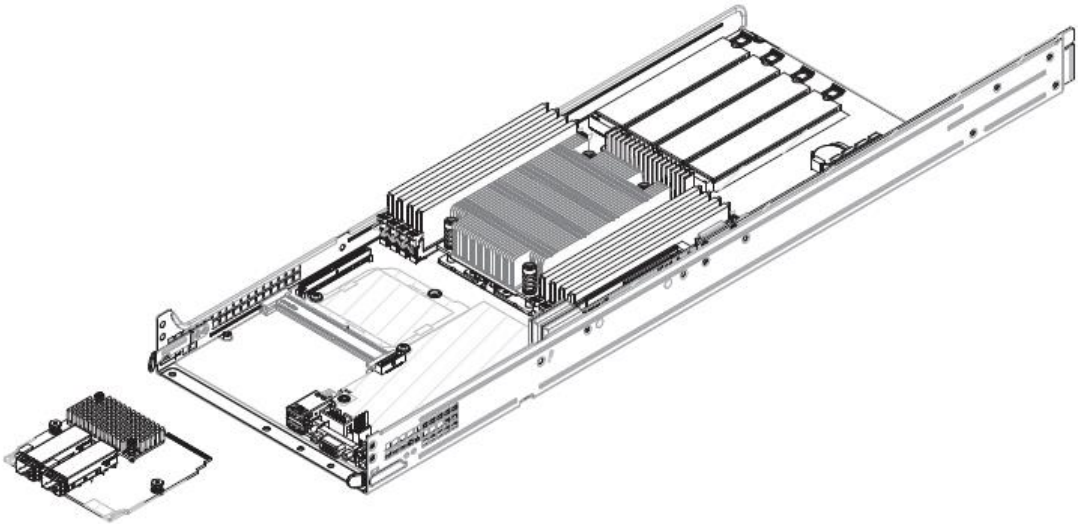
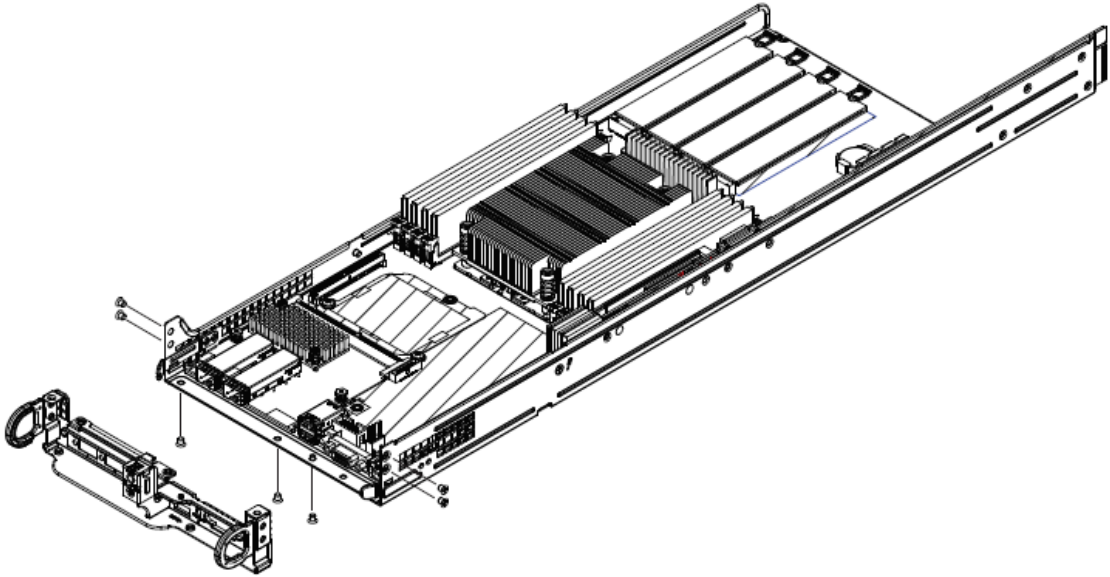

13. Motherboard

Type and number of fastenings: Seven (7) Phillips screws.

Tools required: Screwdriver with PH2 bit.

Procedure:

1. Remove the adapter card, both riser cards, and SIOM first, as instructed in previous sections.
2. Remove all seven Phillips screws. Lift the motherboard from its base.

