

Information for Lot 9 of ErP (Ecodesign)

For **AS-2124GQ-NART+**

This addendum addresses European Union (EU) Ecodesign requirements for servers and storage products. All data and ratings within this addendum are in reference only to the Supermicro product(s) in the manual. The below information conforms to requirements laid down in Annex II of the Commission Regulation 2019/424.

- 3(1)(a): See Section 1.1 of the system manual for the product type.
- 3(1)(b): See the title page and preface of the system manual for the trademark and manufacturer's address.
- 3(1)(c): See the title page of the system manual for product model number(s).
- 3(1)(d): See the serial number on the physical system to determine the year of manufacture.
- 3(1)(e-j): **PSU Efficiency and Power Factor Value (Table) (From 80 Plus report)**

PSU Model #: PWS-3K02G-2R Watts: 3000W	PSU Efficiency				Power Factor
% of Rated Load	10 %	20 %	50 %	100 %	50 %
Single Output (AC-DC)	90 %	94 %	96 %	91 %	0.98
Multiple Output (AC-DC)	N/A	N/A	N/A	N/A	N/A

System (EUT) Efficiency in Idle State Power (Table)

Representative Configurations	Measured Idle State Power (W)	Calculated Idle Power Allowance (W)
High-End Performance Configuration	652	687.05
Typical Configuration	N/A	N/A
Low-End Performance Configuration	465.3	255.43

System (EUT) Efficiency in Active State Power (Table)

Representative Configurations	Active State Efficiency Score (Effserver)	Minimum Active State Efficiency for 2-Socket Server
High-End Performance Configuration	31.9	9.5
Typical Configuration	N/A	
Low-End Performance Configuration	16.1	

3(1)(k): The operating condition class is **A2**.

Operating condition class	Dry bulb temp °C		Humidity range, non-condensing		Max dew point (°C)	Maximum rate of change (°C/hr)
	Allowable range	Recommended range	Allowable range	Recommended range		
A1	15- 32	18-27	- 12 °C Dew Point (DP) and 8 % relative humidity (RH) to 17 °C DP and 80 % RH	- 9 °C DP to 15 °C DP and 60 % RH	17	5/20
A2	10-35	18-27	- 12 °C DP and 8 % RH to 21 °C DP and 80 % RH	Same as A1	21	5/20
A3	5-40	18-27	- 12 °C DP and 8 % RH to 24 °C DP and 85 % RH	Same as A1	24	5/20
A4	5-45	18-27	- 12 °C DP and 8 % RH to 24 °C DP and 90 % RH	Same as A1	24	5/20

3(1)(l): The idle state power at the higher boundary temperature of the operating conditions class is 769.36 W.

3(1)(m): The active state efficiency and performance is 31.9.

3(1)(n): There are two methods by which a user can securely delete data from this system. The user performing secure data deletion should be an IT professional.

The first is with a Unified Extensible Firmware Interface (UEFI) shell utility. This utility works on X10/X11/H11/H12/M11 motherboard series with onboard SATA/NVMe devices. Any user may access and download this utility through following link:

https://www.supermicro.com/about/policies/disclaimer.cfm?url=/wftp/utility/Lot9_Secure_Data_Deletion_UTILITY/

Download the shell utility package and extract it to a USB flash drive, then plug the drive into the server for which secure data deletion is necessary. Then turn the system on. Navigate to the BIOS setup menu, then place the server system into the UEFI shell environment. Follow the instructions in the README file to invoke the utility and complete the deletion.

The second method is through the secure data deletion tool provided by the original manufacturer of the hard drive. This should be used in a scenario where the shell utility is not applicable. Each manufacturer should have the tool available on their website. If needed, please look on the hard drive label for the name of the manufacturer and model information.

3(1)(o): List of recommended combinations of blade servers with chassis: N/A.

3(1)(p): List of all current SKUs within this product family: AS-2124GQ-NART+.

3(3)(a): There is no use of cobalt in batteries in this product.

The indicative weight range of neodymium in the HDD is 0.0 if manufactured by Western Digital, and is between 5-25 grams if manufactured by Seagate.

3(3)(b): Please see the disassembly instructions on the next page.

Illustrated System Disassembly Instructions

Please note: All the illustrations in the below disassembly instructions are for demonstration only. Components shown here may not match exactly with the components in your system.

CAUTION: Always power off the system and unplug the power cord(s) first before disassembling the system!

1. Power Supply Module

Type and number of fastenings: One (1) latch per module.

Tools required: None.

Procedure: Unplug the power cord from the power supply. Push the release tab on the back of the power supply module to the side and pull the module straight out.

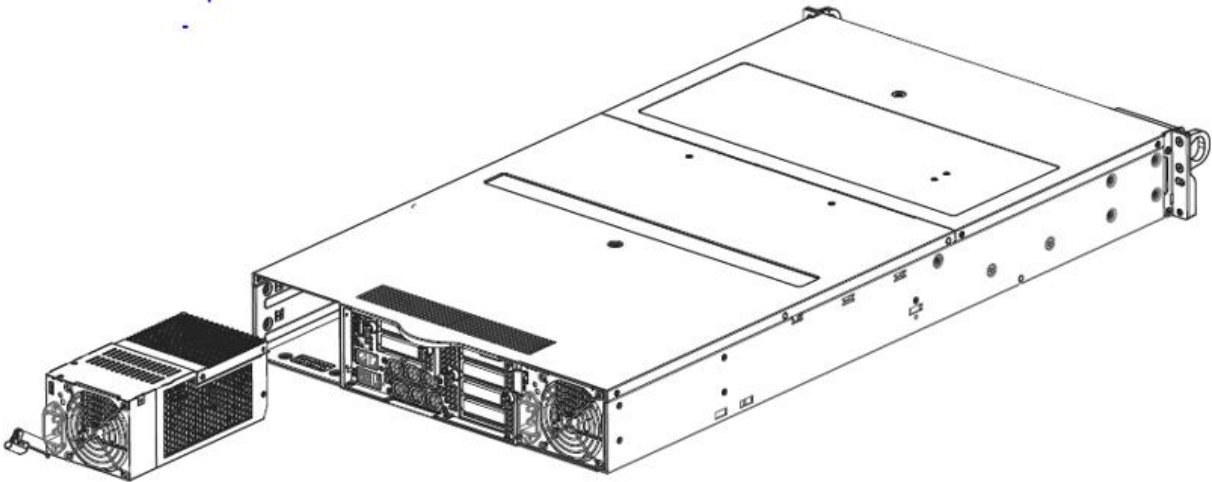

2. Data Storage Devices

Type and number of fastenings: One (1) locking lever.

Tools required: None.

Procedure: Lift the locking lever and pull the drive out of the chassis.

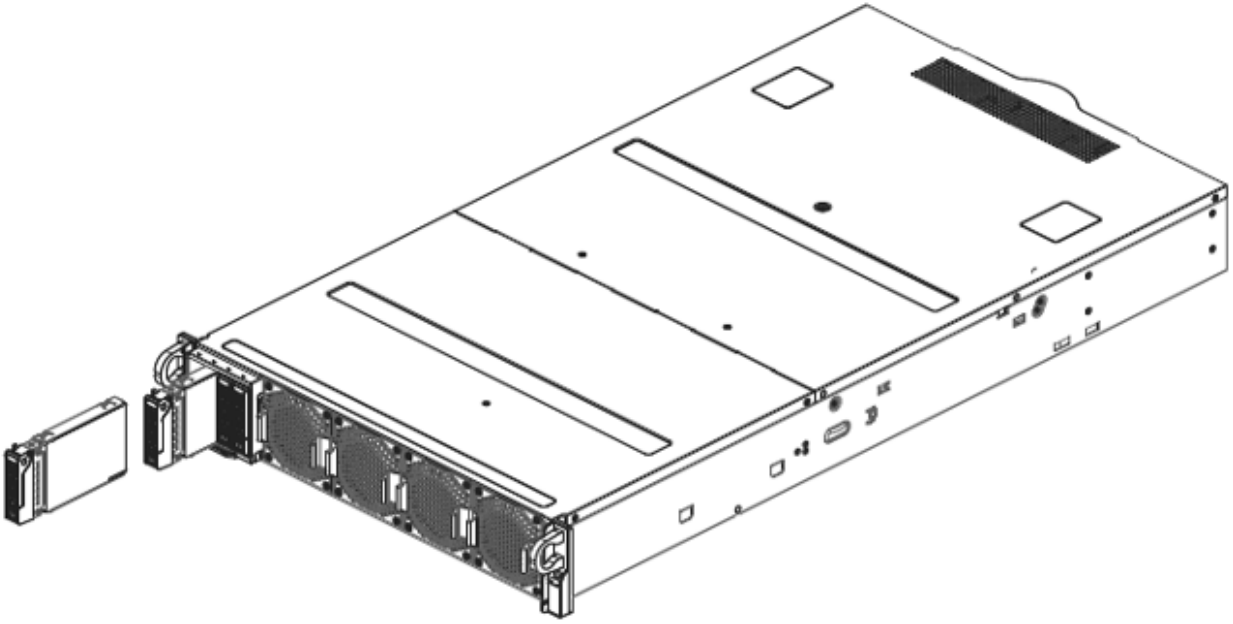

3. Fans

Type and number of fastenings: One (1) locking lever.

Tools required: None.

Procedure: Press the locking levers and pull the fan module out of the chassis.

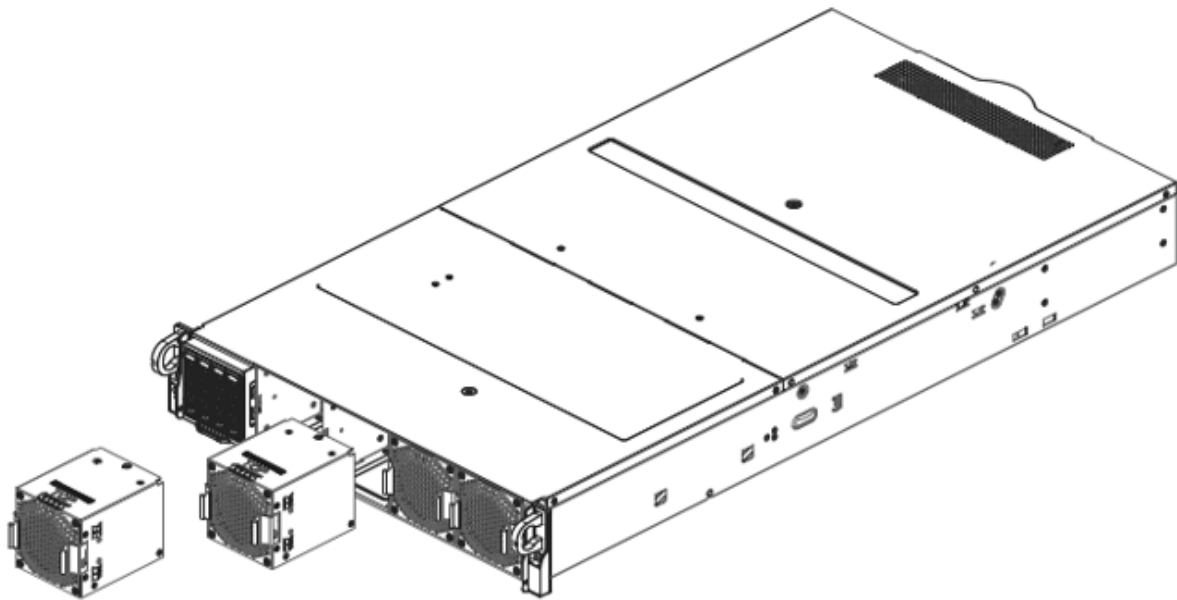

4. Chassis Cover

Type and number of fastenings: 10 screws.

Tools required: Screwdriver with PH2 bit.

Procedure:

1. Remove the four screws on the sides and one screw on the top of the front-facing cover to release and remove it from the chassis.
2. Remove the two screws on the sides and three screws on the top of the rear-facing cover to release and remove it from the chassis.
3. Push the rear top cover toward the rear of the unit, which will separate the two top covers. Lift up each top cover to remove.

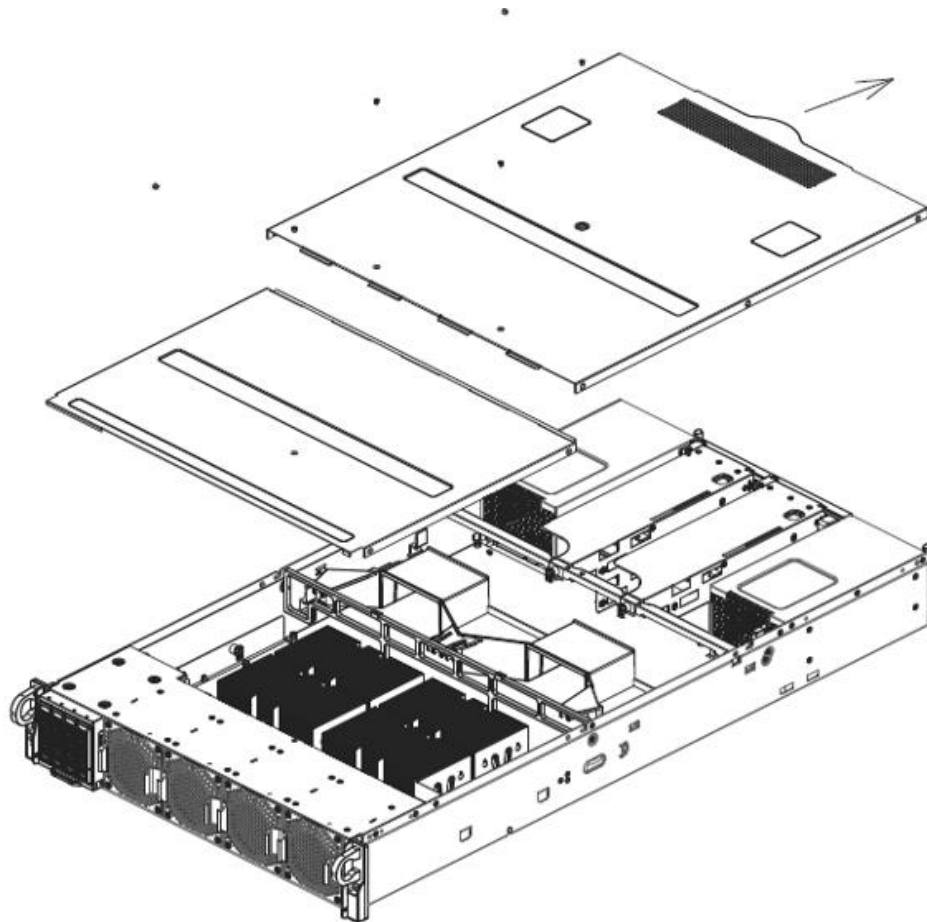

5. Air Shroud

Type and number of fastenings: None.

Tools required: None.

Procedure: Lift the plastic air shroud up and away from the motherboard.

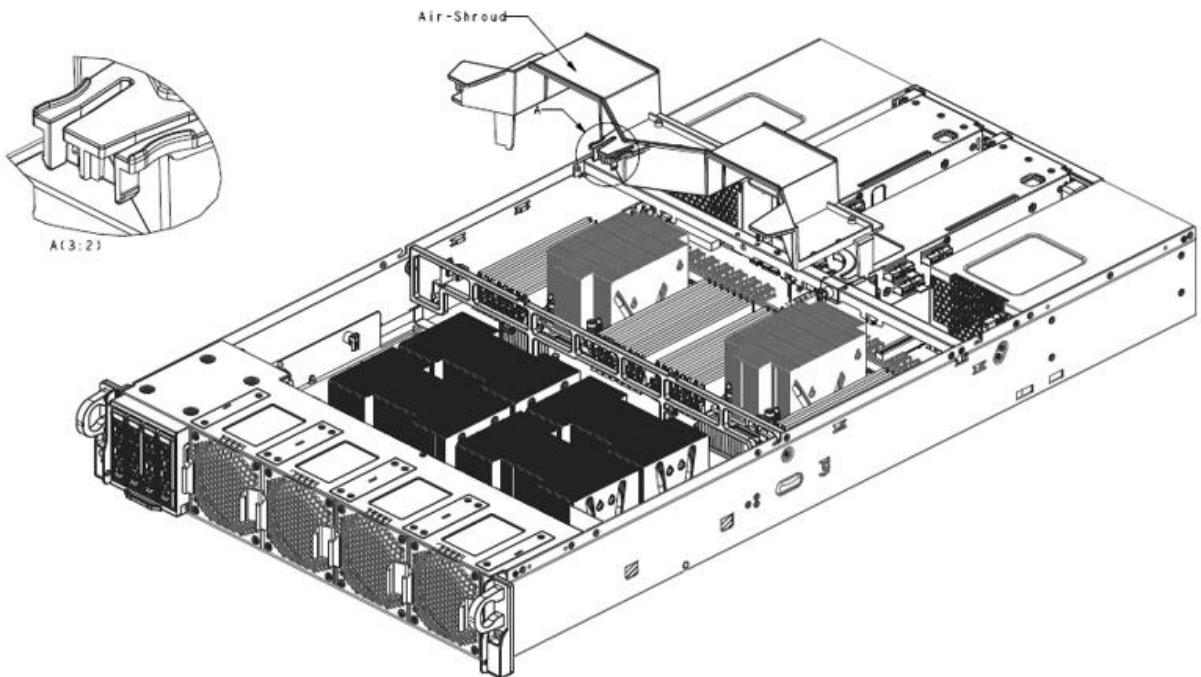

6. Batteries

Type and number of fastenings: One (1) latch.

Tools required: None.

Procedure: Push aside the small clamp that covers the edge of the battery. When the battery is released, lift it out of the holder.

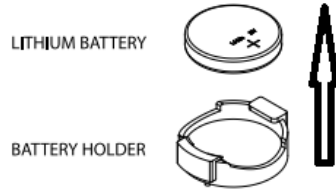

7. Memory

Type and number of fastenings: Two (2) latches per memory module.

Tools required: None.

Procedure: Press both release tabs on the ends of the memory module to unlock it. Once the module is loosened, remove it from the memory slot.

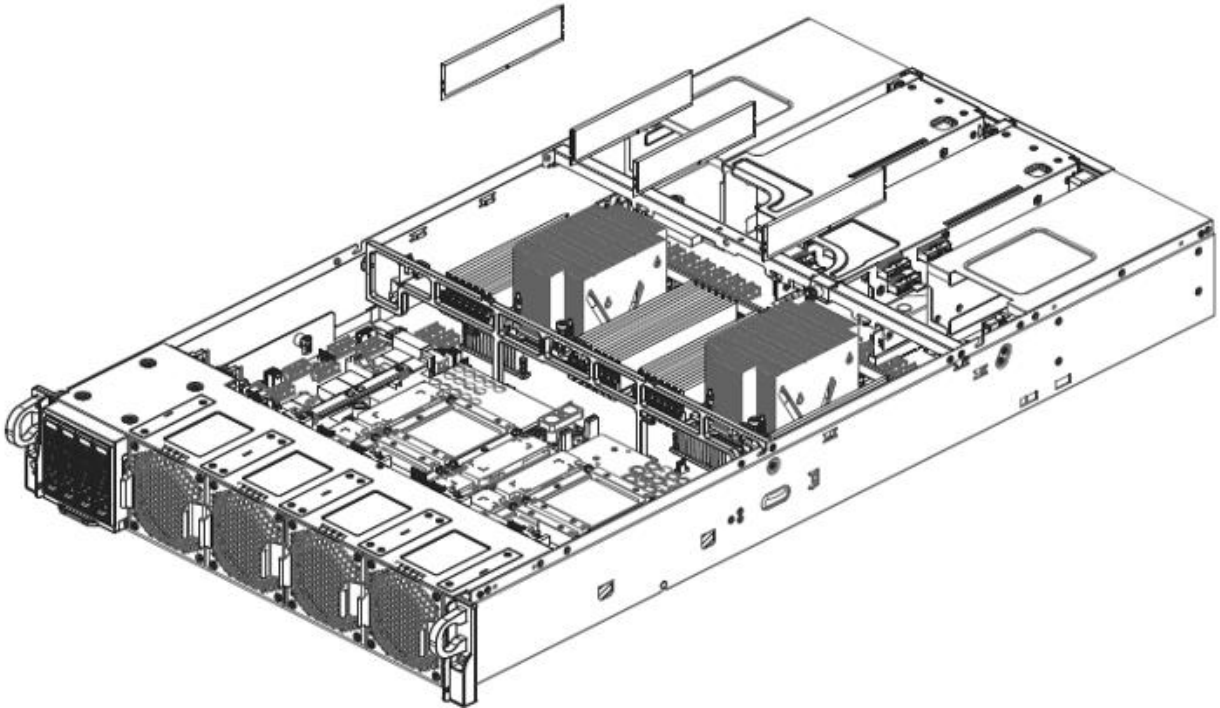

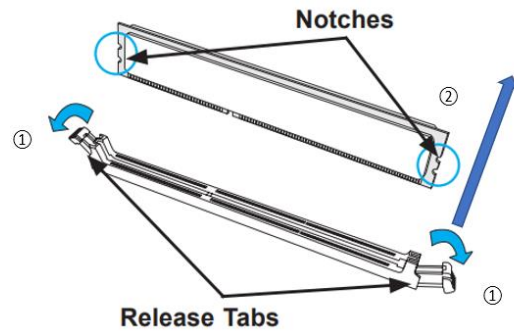

8. PCI-E Holder

Type and number of fastenings: None.

Tools required: None.

Procedure:

1. Begin by removing the riser assemblies from left to right (when viewed from the rear).
2. At the rear of the chassis, remove the PCI riser by unlatching the riser release at four locations: there are three at the rear of the chassis and one for each riser located at the metal chassis rear crossbar.
3. Slide the PCI riser out of expansion slot from the back of the chassis by lifting each riser assembly vertically.
4. Once the riser releases are extended to the open position, lift each riser assembly vertically. Be careful not to damage the power or data cables attached to the assemblies. If more room is needed, the cables can be detached; however, be sure to note the cable numbers and their mated connectors.

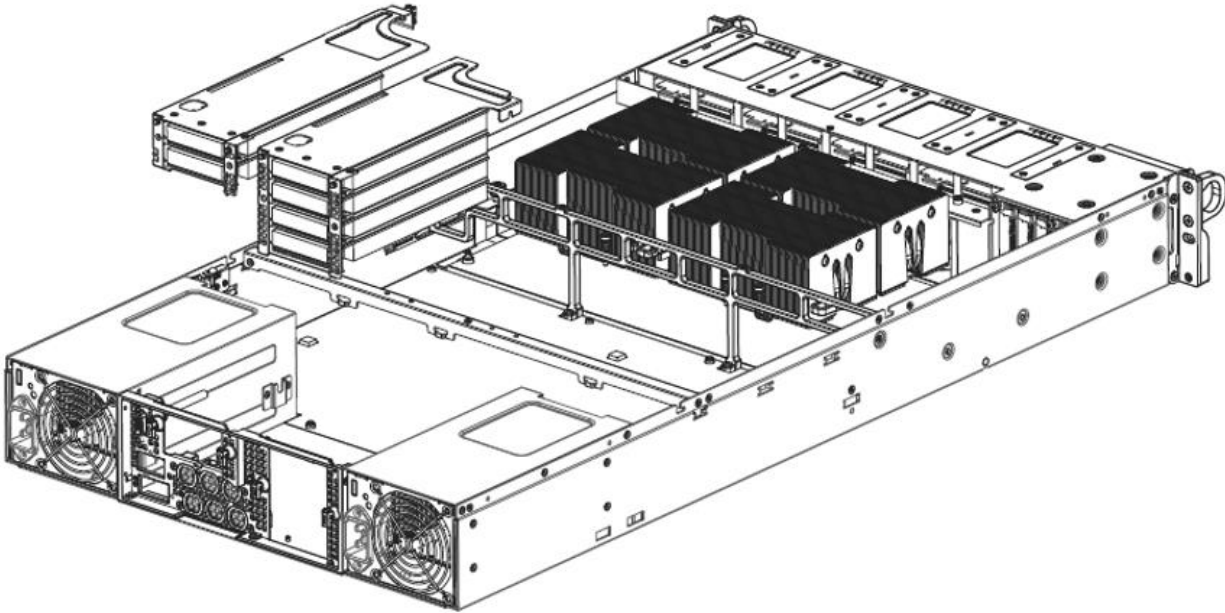

9. Processor and Heatsink

Type and number of fastenings: Three (3) T20 Torx screws.

Tools required: Screwdriver with T20 Torx bit.

Procedure:

1. Wait for the heatsink to cool down before removing it.
2. Remove the heatsink attached to the top of the CPU package.
3. Clean the thermal grease left by the heatsink on the CPU package lid to limit the risk of its contaminating the CPU package landing pads or contacts in the socket housing.
4. Unscrew the plate in the 3-2-1 order, then lift the force frame up to the vertical position.
5. Lift the rail frame using the lift tabs near the front end of the rail frame. Note that the rail frame is spring loaded, so be careful when lifting it up into a vertical position.
6. Grip the handle of the carrier frame and pull upward to extract it from the rail frame. Return the carrier frame/CPU package to its original shipping container.
7. Grip the handle on the external cap and return it to the rail frame, sliding it downward until it rests in the frame.
8. Gripping the rail frame, rotate it downward until it rests above and locks over the socket housing in the horizontal position.
9. Push and rotate down the force frame until it is over the external cap and rail frame in a horizontal position.
10. While holding down the force frame, secure it back to the socket frame by securing screw 1 in place. Note that it is not necessary to tighten down screws 2 and 3 without a CPU package in place.

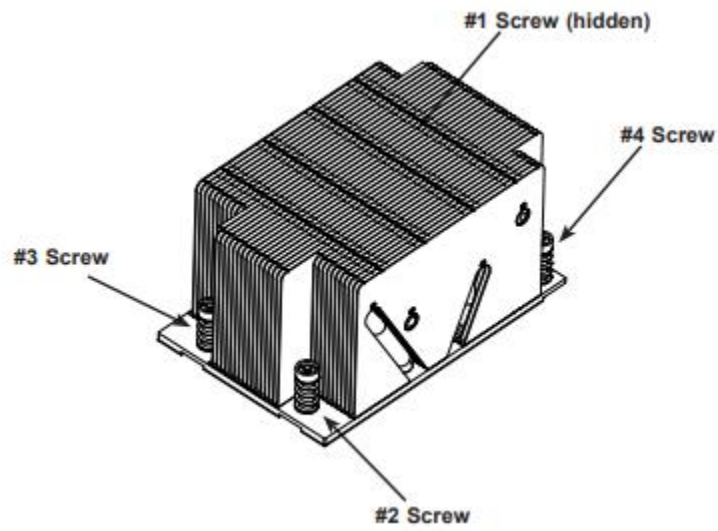
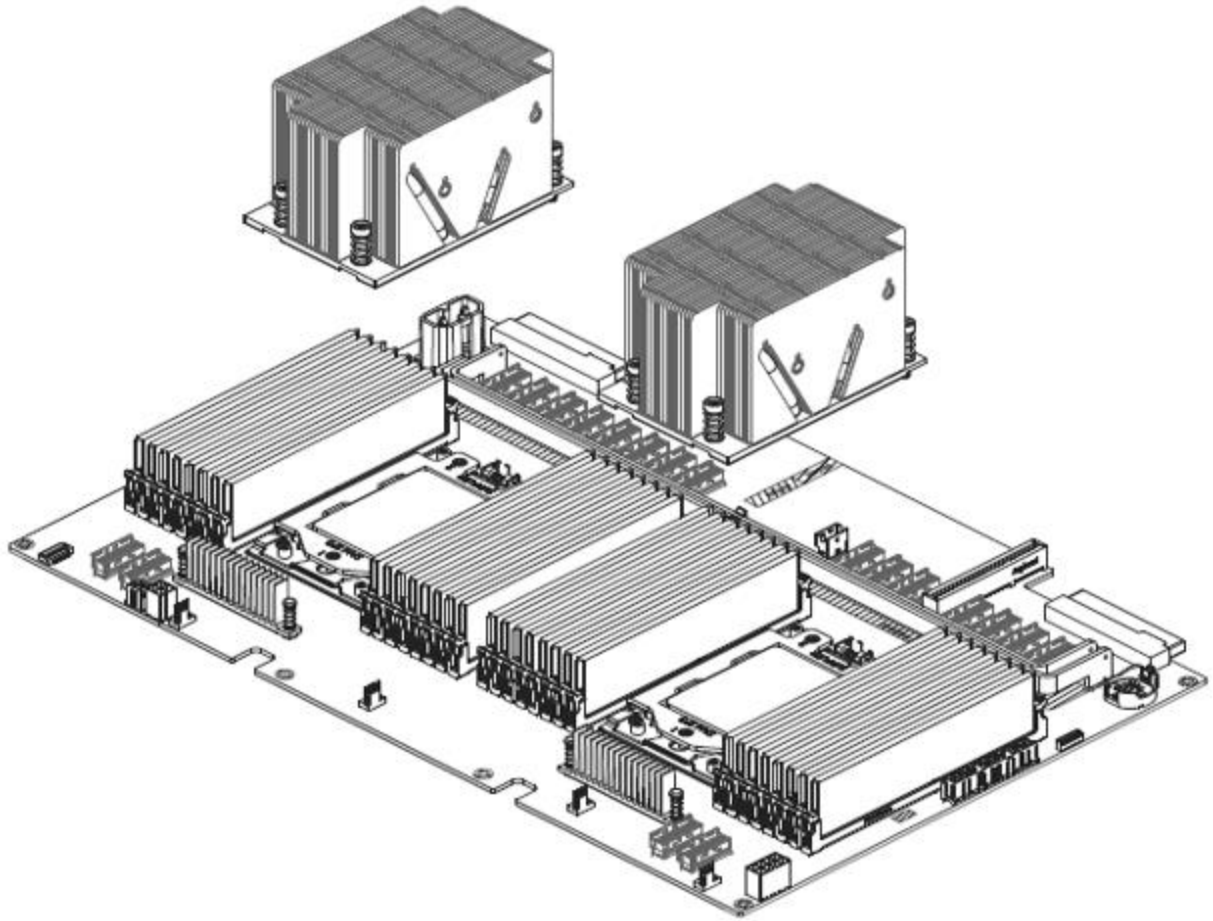

10. Motherboard

Type and number of fastenings: Eight (8) Phillips screws.

Tools required: Screwdriver with PH2 bit.

Procedure: Remove the screws and lift the motherboard from its base.

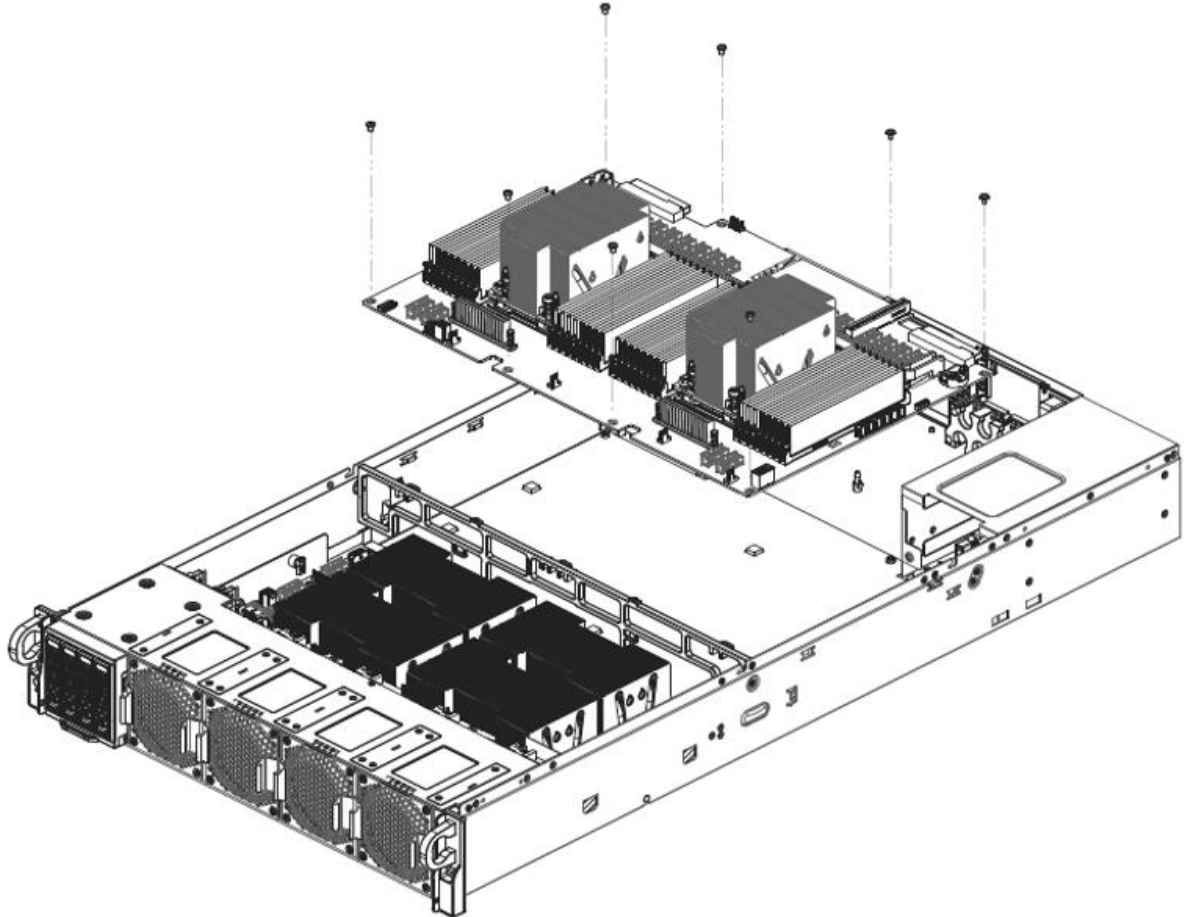

11. PCI-E Transition Board

Type and number of fastenings: Four (4) Phillips screws.

Tools required: Screwdriver with PH2 bit.

Procedure: Remove the screws and lift the PCI-E transition board from the chassis.

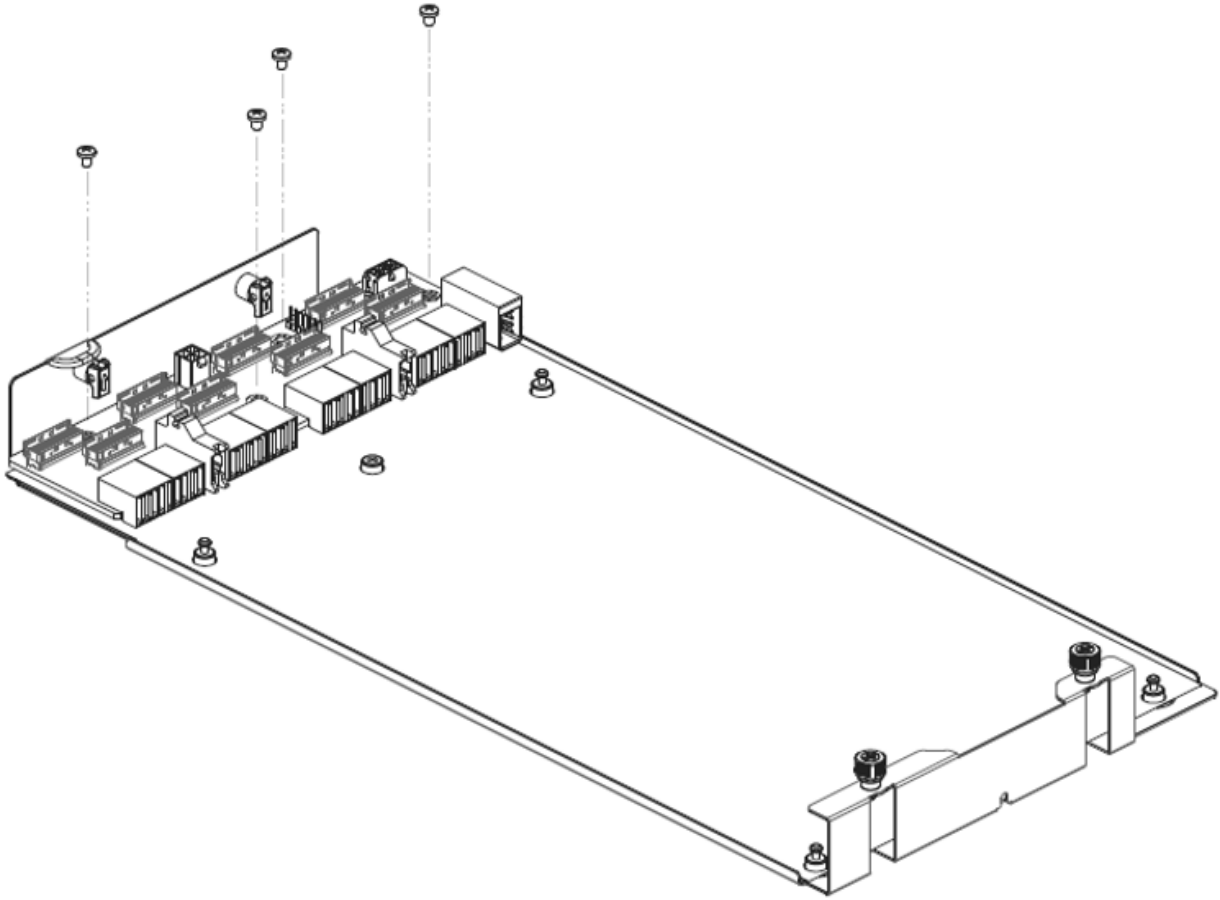

12. GPU Tray

Type and number of fastenings: Two (2) Phillips screws.

Tools required: Screwdriver with PH2 bit.

Procedure: Remove the screws and lift the GPU tray from its base.

