

Information for Lot 9 of ErP (Ecodesign)

This addendum addresses European Union (EU) Ecodesign requirements for servers and storage products. All data and ratings within this addendum are in reference only to the Supermicro product(s) in the manual. The below information conforms to requirements laid down in Annex II of the Commission Regulation 2019/424.

- 3(1)(a): See Section 1.1 of the system manual for the product type.
- 3(1)(b): See the title page and preface of the system manual for the trademark and manufacturer's address.
- 3(1)(c): See the title page of the system manual for product model number(s).
- 3(1)(d): See the serial number on the physical system to determine the year of manufacture.
- 3(1)(e-j): **PSU Efficiency and Power Factor Value (Table) (From 80 Plus report)**

PSU Model #: PWS-1K24A-1R Watts: 1200	PSU Efficiency				Power Factor
	10 %	20 %	50 %	100 %	
% of Rated Load					50 %
Single Output (AC-DC)	90.70 %	95.20 %	96.01 %	93.74 %	0.99

System (EUT) Efficiency in **Idle State** Power (Table)

Representative Configurations	Measured Idle State Power (W)	Calculated Idle Power Allowance (W)
High-End Performance Configuration	367.9	837.76
Typical Configuration	N/A	N/A
Low-End Performance Configuration	159.3	276.71

System (EUT) Efficiency in **Active State** Power (Table)

Representative Configurations	Active State Efficiency Score (Effserver)	Minimum Active State Efficiency for 2-Socket Server
High-End Performance Configuration	17.6	9.5
Typical Configuration	N/A	
Low-End Performance Configuration	26.6	

3(1)(k): The operating condition class is **A2**.

Operating condition	Dry bulb temp °C		Humidity range, non-condensing		Max dew point (°C)	Maximum rate of change
	Allowable range	Recommend	Allowable range	Recommended range		
A1	15- 32	18-27	- 12 °C Dew Point (DP) and 8 % relative humidity (RH) to 17 °C DP and 60 % RH	- 9 °C DP to 15 °C DP and 60 %	17	5/20
A2	10-35	18-27	- 12 °C DP and 8 % RH to 21 °C DP and 80 %	Same as A1	21	5/20
A3	5-40	18-27	- 12 °C DP and 8 % RH to 24 °C DP and 85 %	Same as A1	24	5/20
A4	5-45	18-27	- 12 °C DP and 8 % RH to 24 °C DP and 90 %	Same as A1	24	5/20

3(1)(l): The idle state power at the higher boundary temperature of the operating conditions class is 367.9 W.

3(1)(m): The active state efficiency and performance is 17.6.

3(1)(n): There are two methods by which a user can securely delete data from this system. The user performing secure data deletion should be an IT professional.

The first is with a Unified Extensible Firmware Interface (UEFI) shell utility. This utility works on X10/X11/H11/H12/M11 motherboard series with onboard SATA/NVMe devices. Any user may access and download this utility through following link:

https://www.supermicro.com/about/policies/disclaimer.cfm?url=/wftp/utility/Lot9_Secure_Data_Deletion_Utility/

Download the shell utility package and extract it to a USB flash drive, then plug the drive into the server for which secure data deletion is necessary. Then turn the system on. Navigate to the BIOS setup menu, then place the server system into the UEFI shell environment. Follow the instructions in the README file to invoke the utility and complete the deletion.

The second method is through the secure data deletion tool provided by the original manufacturer of the hard drive. This should be used in a scenario where the shell utility is not applicable. Each manufacturer should have the tool available on their website. If needed, please look on the hard drive label for the name of the manufacturer and model information.

3(1)(o): List of recommended combinations of blade servers with chassis: N/A.

3(1)(p): List of all current SKUs within this product family: SYS-621H-TN12R.

3(3)(a): There is no use of cobalt in batteries in this product.

The indicative weight range of neodymium in the HDD is 0.0 if manufactured by Western Digital, and is between 5-25 grams if manufactured by Seagate.

3(3)(b): Please see the disassembly instructions on the next page.

Illustrated System Disassembly Instructions

Please note: All the illustrations in the below disassembly instructions are for demonstration only. Components shown here may not match exactly with the components in your system.

CAUTION: Always power off the system and unplug the power cord(s) first before disassembling the system!

1. Chassis Cover

Type and number of fastenings: One (1) release button and latch.

Tools required: None.

Procedure: Press the release button and slide the cover toward the rear.

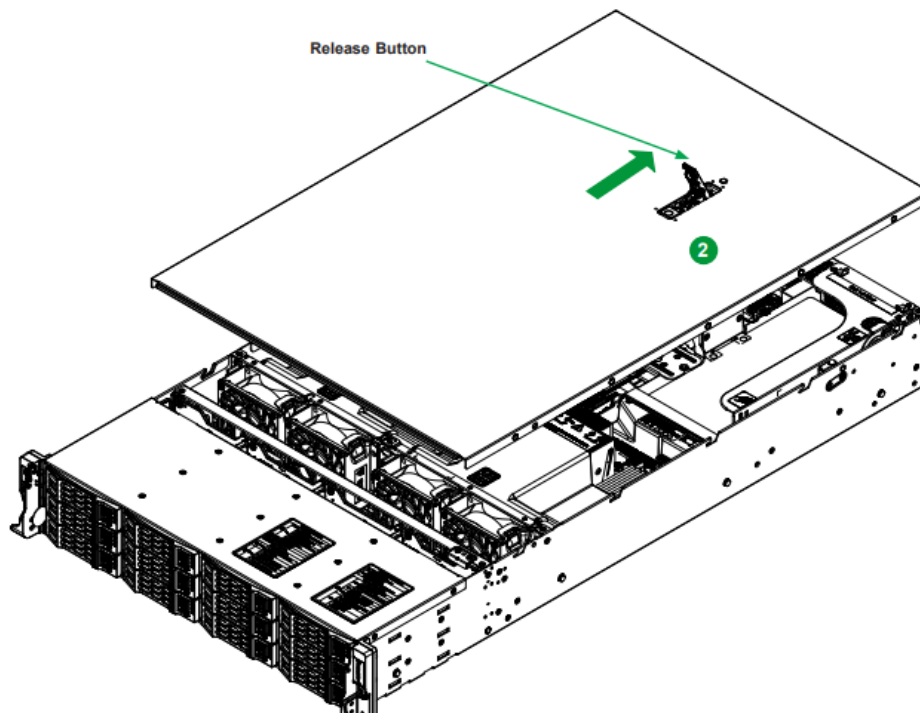

2. Data Storage Devices

Type and number of fastenings: One (1) latch and two (2) locking clasps.

Tools required: None.

Procedure:

1. Push the release button on the drive carrier, which will extend the drive carrier handle.
2. Use the drive carrier handle to pull the drive out of the chassis.
3. Pull the drive out of the carrier.

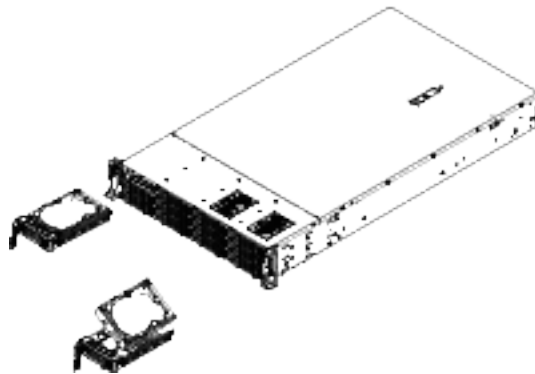

3. Memory

Type and number of fastenings: Two (2) latches per memory module.

Tools required: None.

Procedure: Press both release tabs on the ends of the memory module to unlock it. Once the module is loosened, remove it from the memory slot.

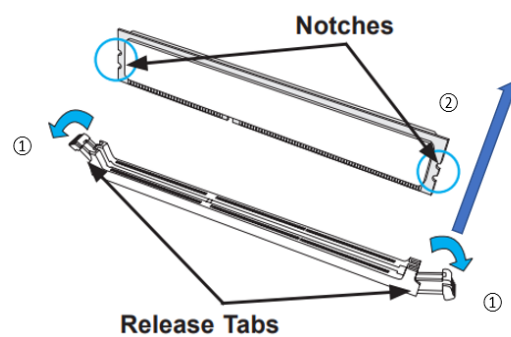

4. Processor

Type and number of fastenings: Four (4) T30 Torx screws.

Tools required: Screwdriver with T30 Torx bit.

Procedure:

1. Use a T30-bit screwdriver to loosen the four peek nuts on the heatsink in the sequence of A, B, C, and D.

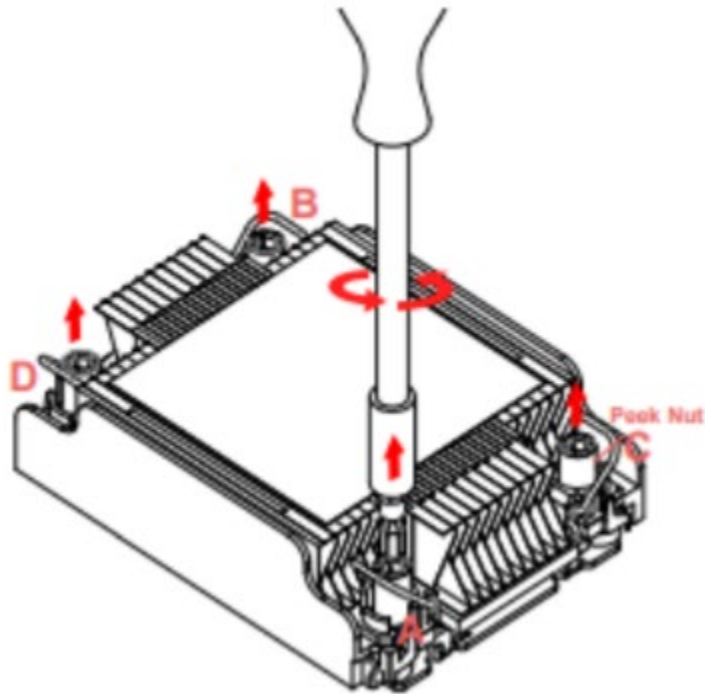

2. Press the four rotating wires inward to unlatch the processor heatsink module, as shown below.

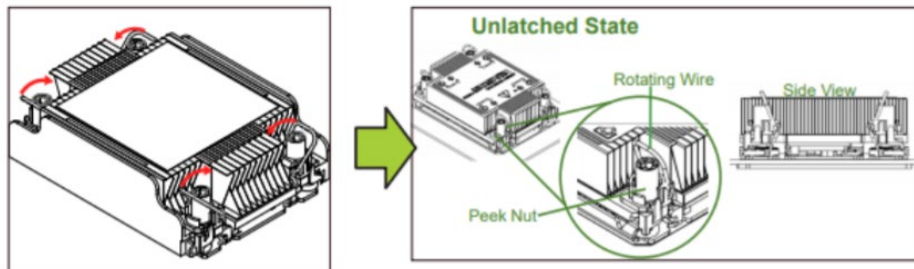

3. Gently lift the processor heatsink module upward to remove it from the processor socket.

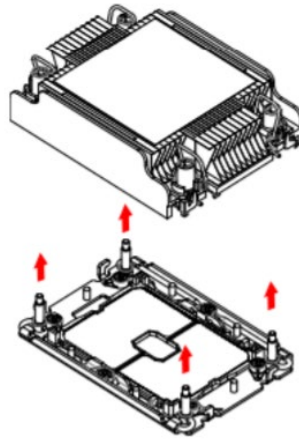

4. Unlock the lever from its locked position and push it upward to disengage the processor from the carrier as shown in the picture. Carefully remove the processor from the carrier. Handle the processor with care to avoid damage.

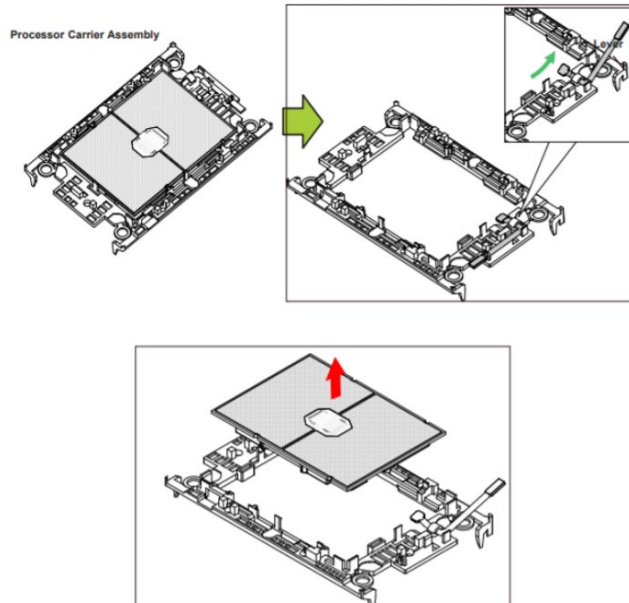

5. Fans

Type and number of fastenings: One (1) fan header per fan.

Tools required: None.

Procedure: Squeeze the tabs on the top of the fan and pull the fan up to disconnect it from the fan cage.

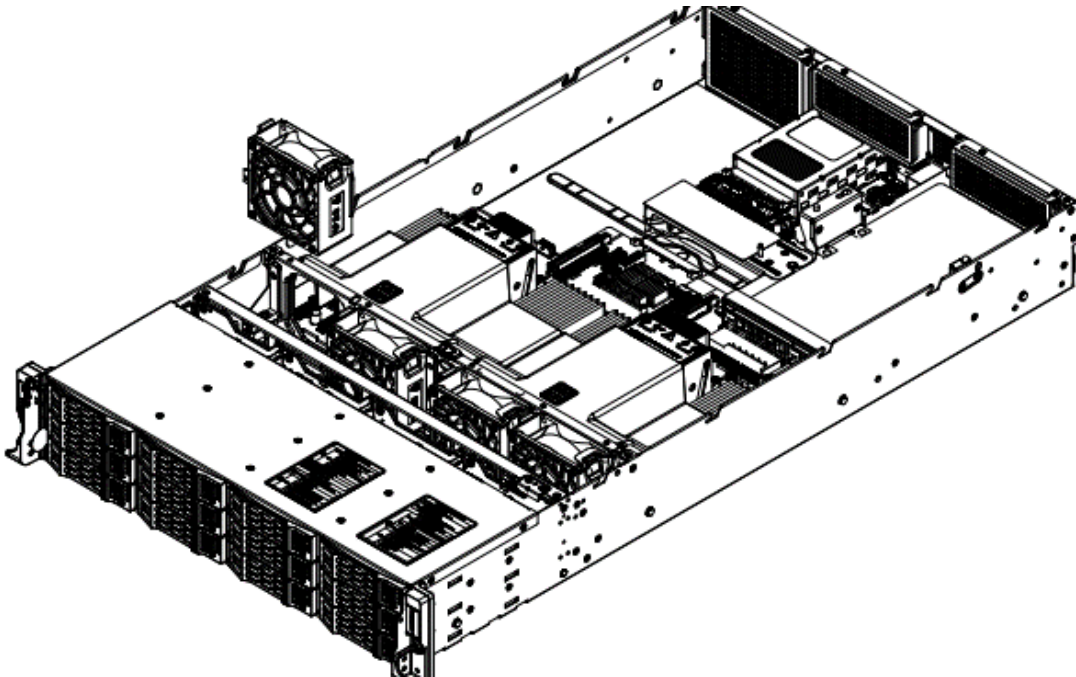

6. Power Supplies

Type and number of fastenings: One (1) latch per module.

Tools required: None.

Procedure: Unplug the power cord from the power supply. Push the release tab on the back of the power supply module to the side and pull the module straight out.

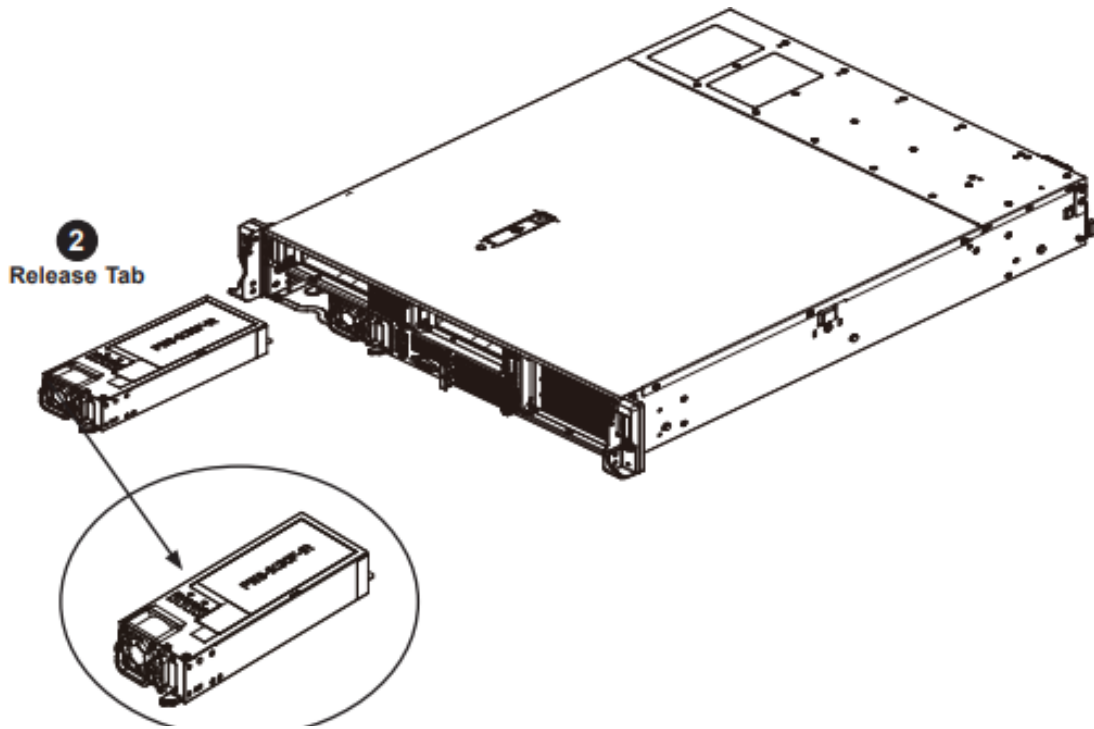

7. AIOM / OCP NIC 3.0 Card

Type and number of fastenings: One (1) thumbscrew.

Tools required: None.

Procedure: Loosen the thumbscrew on the AIOM / OCP NIC 3.0 card and pull the card out from the chassis.

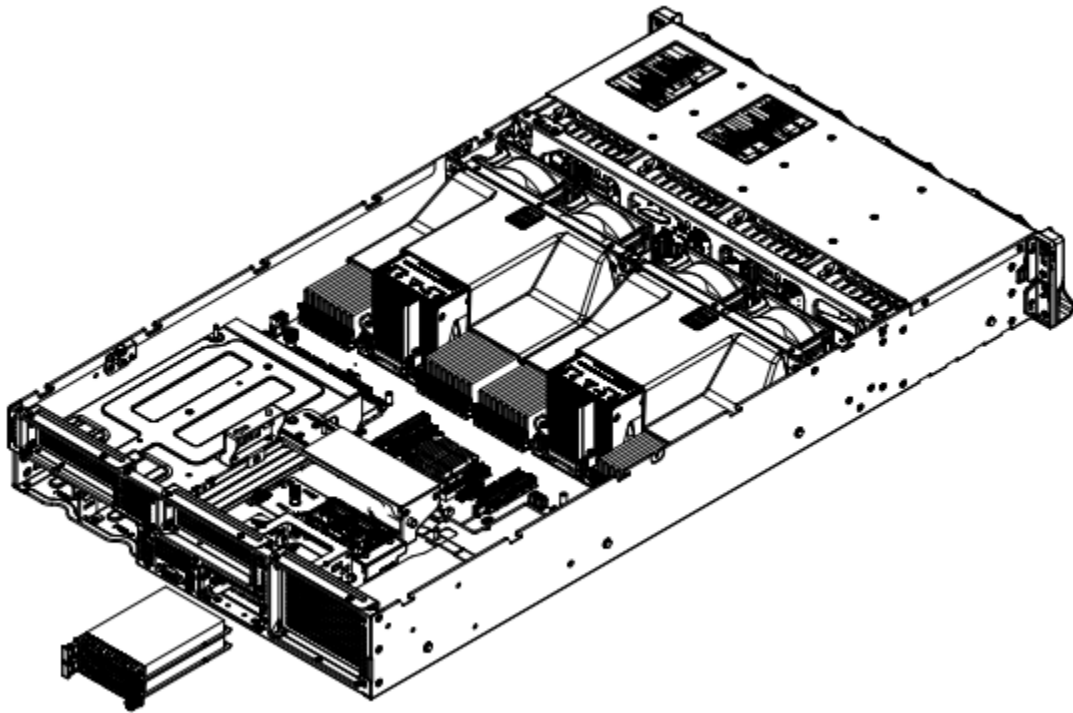

8. AIOM / OCP NIC 3.0 Cable Assembly

Type and number of fastenings: One (1) thumbscrew and two (2) Phillips screws.

Tools required: Screwdriver with PH2 bit.

Procedure: Remove the screws from the cable assembly. Loosen the thumbscrew on the cable assembly and pull the assembly out from the chassis.

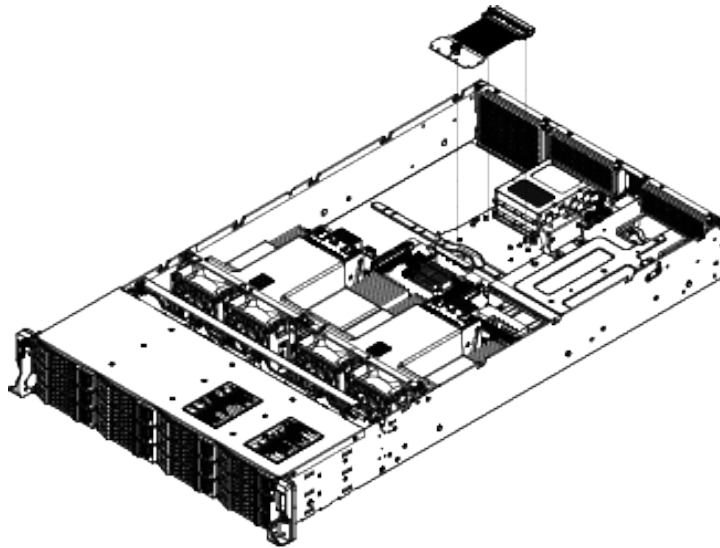

9. PCIe Expansion Card

Type and number of fastenings: One (1) latch per expansion card installed.

Tools required: None.

Procedure: Unplug any cables connected to the riser card. Lift the riser card bracket from the chassis. Unlatch the expansion card and pull the expansion card out from the riser card.

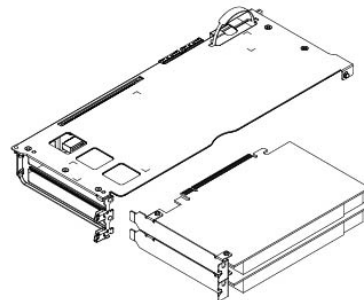
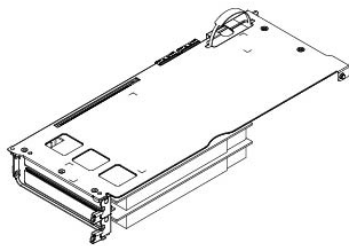
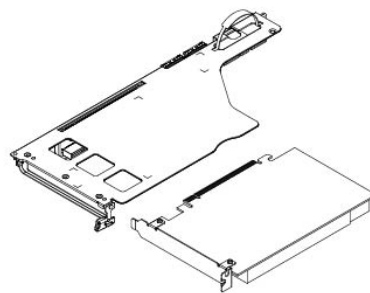
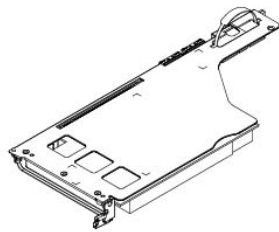

10. Riser Card

Type and number of fastenings: One (1) thumbscrew per riser card.

Tools required: None.

Procedure: Unplug any cables connected to the riser card and lift the riser card bracket from the chassis. Loosen the thumbscrew on the riser card and remove the riser card from the riser card bracket.

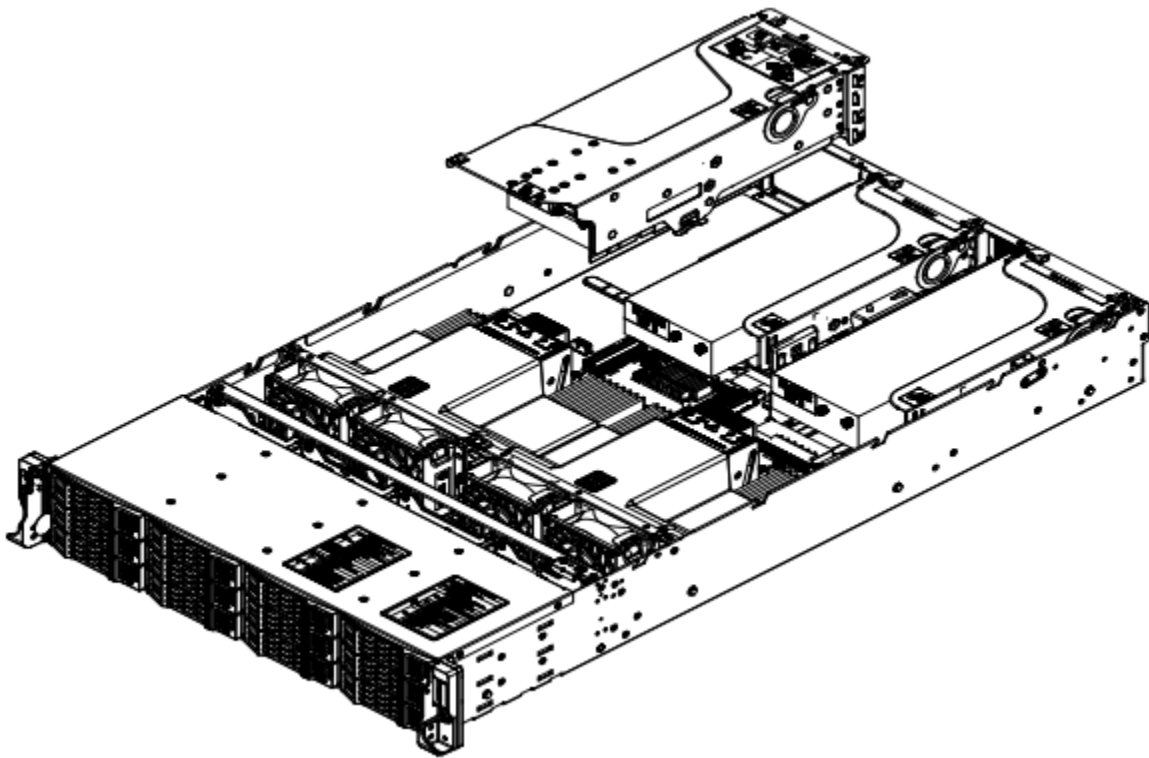

11. Internal Data Storage Devices

Type and number of fastenings: One (1) clip per device installed.

Tools required: None.

Procedure: Press down on the clip, then lift and pull the device out from the motherboard M.2 socket.

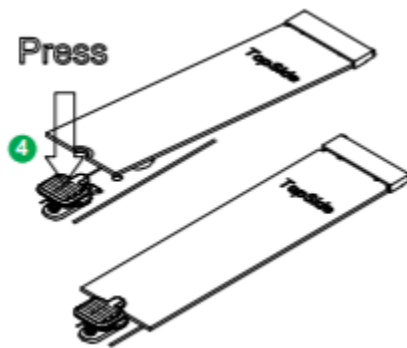

12.I/O Module

Type and number of fastenings: One (1) thumbscrew.

Tools required: None.

Procedure: Unplug any cables connected to the I/O module. Loosen the thumbscrew on the I/O module and remove the module from the chassis base.

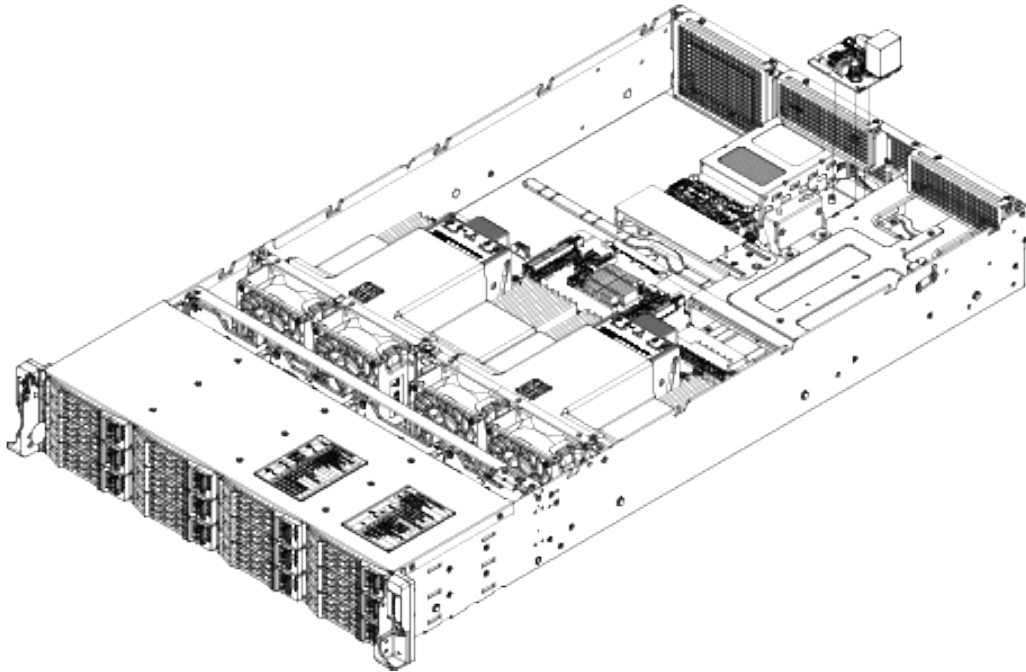

13. Motherboard

Type and number of fastenings: Two (2) thumbscrews.

Tools required: None.

Procedure: Loosen the thumbscrews on the motherboard and slide the motherboard forward to lift the motherboard out of the chassis.

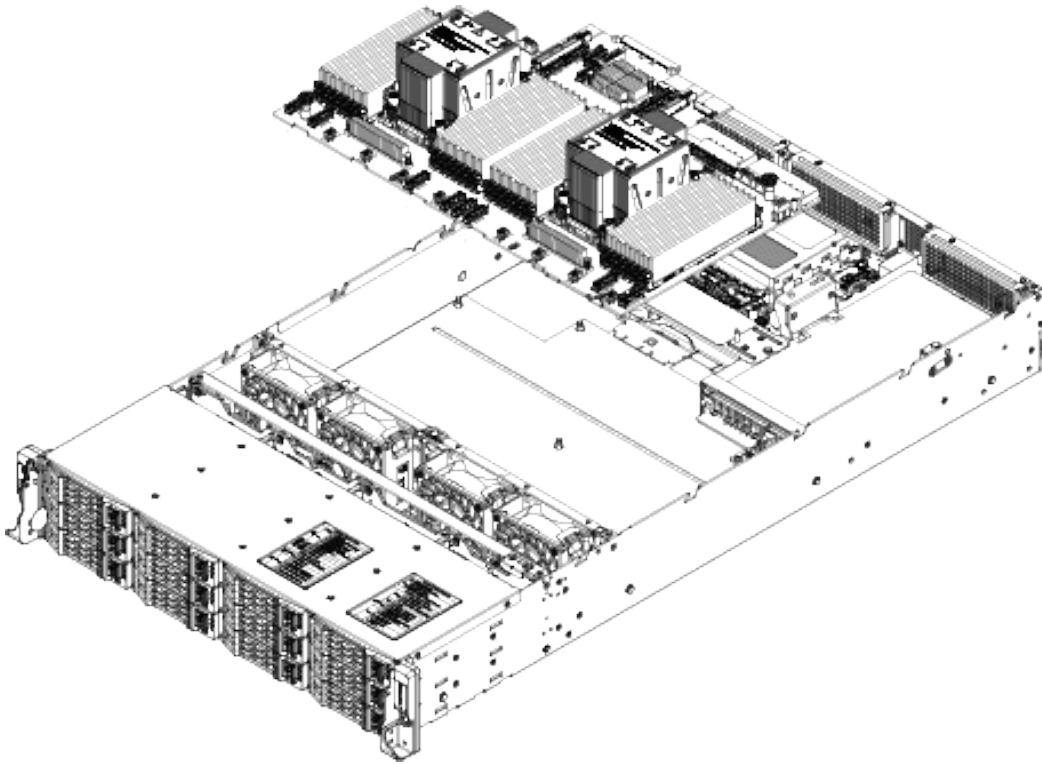

14. Backplane

Type and number of fastenings: Six (6) Phillips screws.

Tools required: Screwdriver with PH2 bit.

Procedure: Disconnect all cables. Pull out the backplane assembly from the chassis. Then remove the six screws that secure the backplane to the assembly. Detach the backplane from the assembly.

